



## Welded Railing

**2-5/8" Hollow Cap x 25' 10" - 129**

**28-63-210** wt/ft: 0.573

accepts 3/4" Picket with 2" Post; Mates w/#133

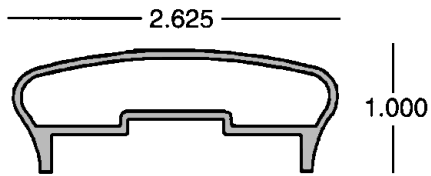

**Accepts Castings:**

End Cap #28: 21-00-135

Wall Mount #52: 21-00-302

**2-5/8" Solid Cap x 25' 10" - 130**

**28-63-200** wt/ft: 0.530

accepts 3/4" Picket w/2" Post; Mates w/#133

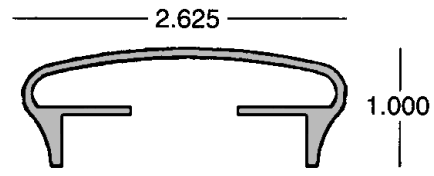

**Accepts Castings:**

End Cap #28: 21-00-135

Wall Mount #52: 21-00-302

**Outside Sleeve x 20' - 133**

**28-63-220** wt/ft: 0.732

mates with #129 and #130

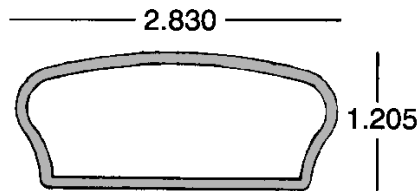

**2" x 1" Hollow Cap x 20' - 131**

**28-63-275** wt/ft: 0.437

accepts 3/4" Picket with 1-1/2" Post

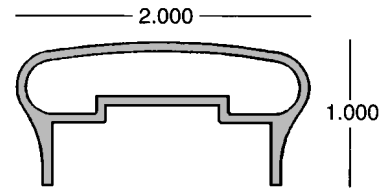

**Accepts Castings:**

End Cap #261: MILL ORDER - 21-00-330

Wall Mount #329: MILL ORDER

**3" Oval Top Cap x 25' - 147**

**28-63-267** wt/ft: 0.635

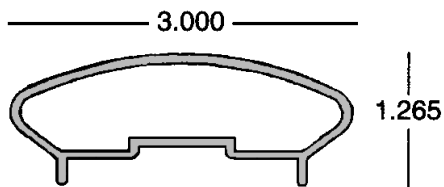

**Accepts Castings:**

Wall Mount: MILL ORDER: 21-00-19

**Outside Sleeve for 3" Oval Top Cap 148**

Mill Order **52-63-8767** wt/ft: 0.941

mates with #147

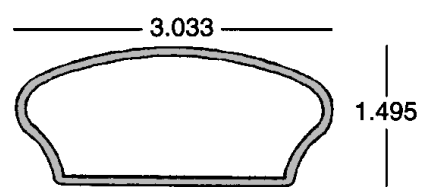

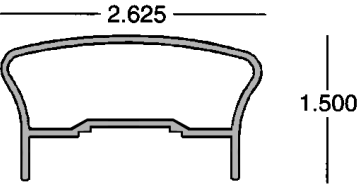
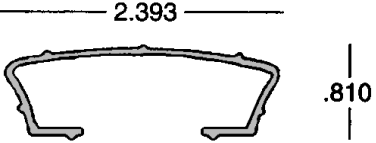
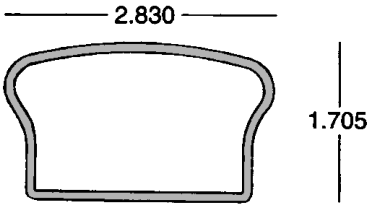
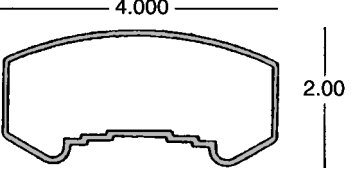
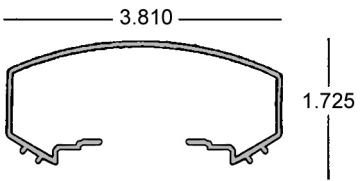
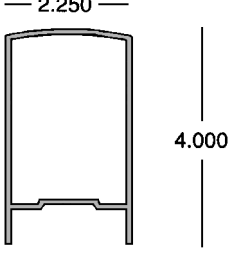
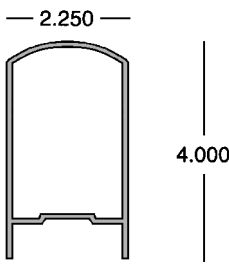
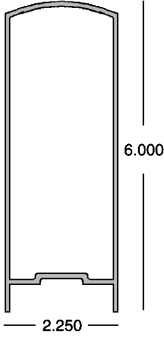
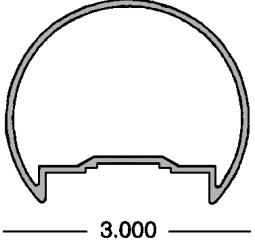
<p><b>2-5/8" Hollow Cap x 25' 10" 135</b>  <b>28-63-215 wt/ft: 0.670</b>  <i>accepts 3/4" and 1" Pickets with 2" Post;</i>  <i>Mates w/ #136 and #137</i></p>  <p><b>Accepts Castings:</b>  End Cap #18: <u>21-00-140</u>, Flat End Cap #18F: <u>21-00-140F</u>; 5052 Flat End Cap: <u>21-5052-140</u>  Wall Mount #271: <u>21-00-160</u></p>	<p><b>2-5/8" Inner Splice x 10' 136</b>  <b>28-63-208 wt/ft: 0.344</b>  <i>mates with #135 (28-63-215)</i></p> 	<p><b>2-5/8" Outside Sleeve x 20' 137</b>  <b>28-63-225 wt/ft: 0.840</b>  <i>mates with #135 (28-63-215)</i></p> 
<p><b>4 x 2 Oval Top Cap x 24' - 152</b>  <b>28-63-285 wt/ft: 1.172</b>  <i>accepts 3/4" Picket ; accepts 1-1/2" and 2" Post</i></p>  <p><b>Accepts Castings:</b>  End Cap #167: MILL ORDER - <u>21-00-313</u>  Wall Mount #680: MILL ORDER - <u>21-00-680</u></p>	<p><b>4 x 2 Inner Splice x 12' 52-63-13204</b>  <b>wt/ft: 0.655</b>  <i>mates with #152 (28-63-285)</i></p> 	<p><b>Top Cap x 24' - 139</b>  <b>28-63-255 wt/ft: 1.477</b>  <i>(less radius)</i>  <i>accepts 3/4" Picket with 2" Post</i></p>  <p><b>Accepts Castings:</b>  End Cap #14: <u>21-00-146</u>  Wall Mount #24: <u>21-00-165</u></p>
<p><b>Top Cap x 24' - 140</b>  <b>28-63-256 wt/ft: 1.274</b>  <i>(more radius)</i>  <i>accepts 3/4" Picket with 2" Post</i></p>  <p><b>Accepts Castings:</b>  End Cap #70: <u>21-00-145</u>  Wall Mount #190W: <u>21-00-190W</u></p>	<p><b>Top Cap x 24' - 144</b>  <b>MILL ORDER 28-63-260</b>  <b>wt/ft: 1.740</b>  <i>accepts 3/4" Picket &amp; 2" Post</i></p> 	<p><b>3" Round Top Cap x 24' - 149</b>  <b>28-63-265 wt/ft: 1.001</b>  <i>accepts 3/4" and 1" Pickets &amp; 2" Post; mates with #150 and #151</i></p>  <p><b>Accepts Castings:</b>  End Cap #97 <u>21-00-120</u>, 5052 Flat End Cap: <u>21-5052-120</u>  Wall Mount #185: <u>21-00-1850</u></p>

**RAILING & FENCE 05**



**Inside Sleeve x 10' - 150**  
**40-63-701** wt/ft: 0.718  
 mates with #149

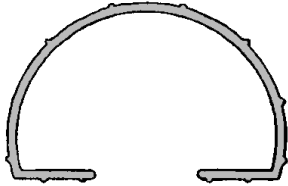

**Outside Sleeve x 10' - 151**  
**28-63-263** wt/ft: 1.042  
 mates with #149

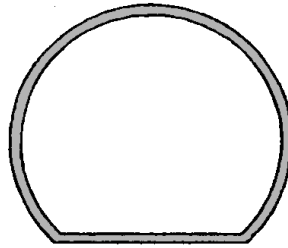

**3" Round Top Cap - Heavy Wall**  
**MILL ORDER - 52-63-12353**  
 wt/ft: 1.489  
 accepts 3/4" Picket & 2" Post; mates with  
 52-63-12354

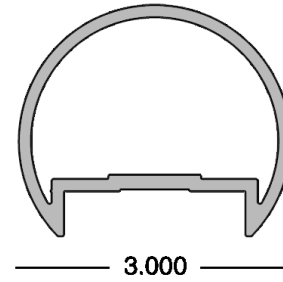

**Accepts Castings:**

End Cap #97 21-00-120, 5052 Flat End  
 Cap: 21-5052-120  
 Wall Mount #185: 21-00-1850

**2-1/2" Colonial Top Rail x 20'**  
**28-63-063 (DE)** wt/ft: 0.600  
**(Wood Style)**  
 Accepts 3/4" Picket

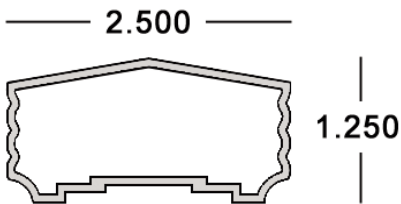

**2-1/4" Colonial Bottom Channel x 20'**  
**28-63-062 (DE)** wt/ft: 0.557  
**(Wood Style)**

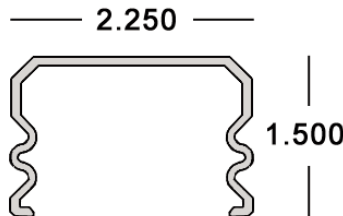

**Inside Sleeve for 3" Round Top Cap**  
**MILL ORDER 52-63-12354** wt/ft: 0.690  
 mates with MILL ORDER 52-63-12353

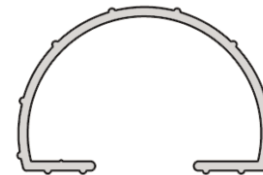

**2" x 1-1/8" Colonial Top Rail**  
**MILL ORDER - 7849-10 (NC)**  
 wt/ft: 0.584  
**(Wood Style)**  
 Accepts 1" Picket

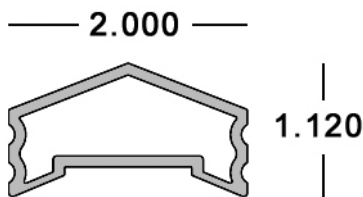

**Handicap Grip Rail x 20' - 132**  
**52-63-1641** wt/ft: 0.665  
 accepts 3/4" Picket with 1-1/4" Post

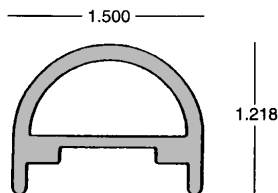

**Accepts Castings:**

End Cap #294 21-00-294

**RAILING & FENCE 06**



# Welded Railing: Dixie Caps



**Dixie Cap x 20' - 154**  
**28-63-100** wt/ft: **0.516**  
 accepts 1" & 1-1/4" Channels

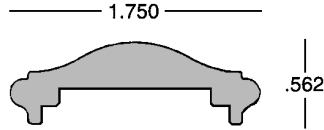

**Dixie Cap x 20'**  
**28-63-103** wt/ft: **0.786**  
 accepts 1" & 1-1/4" Channel

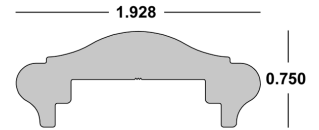

**Dixie Cap x 20' - 158**  
**28-63-230** wt/ft: **1.180**  
 accepts 1-1/4" & 1-1/2" Channels

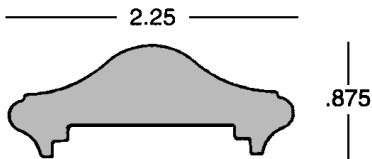

**Dixie Cap x 20' - 155**  
**28-63-105** wt/ft: **0.413**  
 accepts 1-1/2" Channel

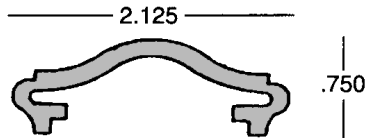

**Dixie Cap x 20' - 156**  
**28-63-110** wt/ft: **0.668**  
 accepts 1", 1-1/4" & 1-1/2" Channel

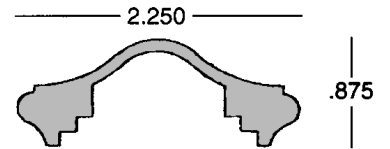

**2-1/4" Dixie Cap x 20'**  
**28-63-111** wt/ft: **0.722**  
 with screw boss; accepts 1-1/2" Channel

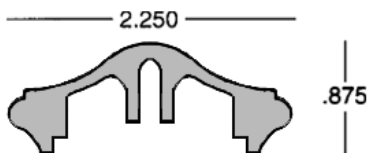

**2-5/8" x 1" Hollow Dixie Cap x 25' 10"**  
**28-63-290** wt/ft: **0.558**  
 accepts 3/4" & 1" Pickets; 2 x 7/16" Channel; 2" Post  
 mates with 28-63-291

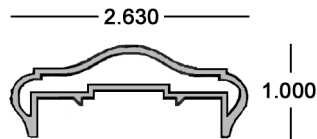

**Accepts Castings:**  
 End Cap #RW-29: [21-00-235](#)  
 Wall Mount #RW-29: [21-00-230](#)

**2-5/8" x 1-1/2" Hollow Dixie Cap x 25' 10"**  
**28-63-295** wt/ft: **0.569**  
 accepts 3/4" & 1" Pickets; 2 x 7/16" Channel; 2" Post; mates with 28-63-296

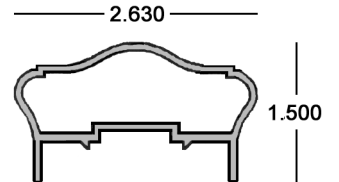

**Accepts Castings:**  
 End Cap #RW-30: [21-00-245](#)  
 Wall Mount #RW-30: [21-00-240](#)

**Outside Sleeve x 20'**  
**28-63-291** wt/ft: **0.500**  
 mates with 28-63-290

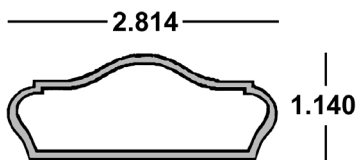

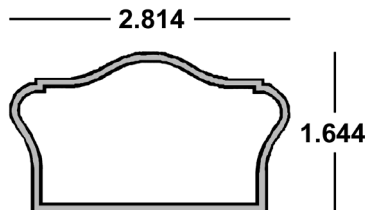

**Outside Sleeve x 20'**  
**28-63-296** wt/ft: **0.571**  
 mates with 28-63-295



RAILING & FENCE 07

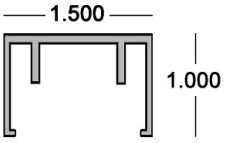
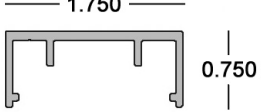
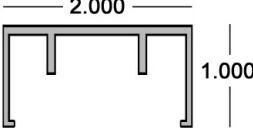
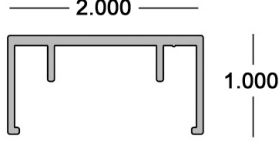
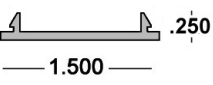
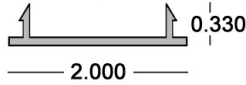

# Railing Channel

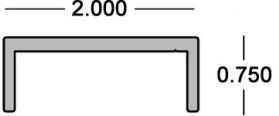
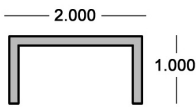
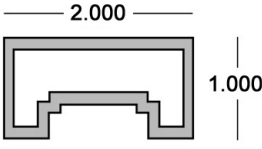
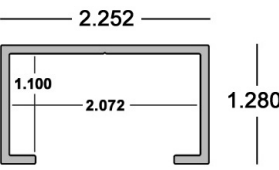
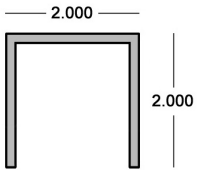
<p><b>1.5 x 1 (.093/.056) Railing Channel x 25'</b> 13-63-300 wt/ft: 0.332 6063-T5 Receives .750 picket; Mates with 13-63-305</p>  <p><b>Accepts Casting:</b> Wall Mount HR-12A #68: 21-00-183</p>	<p><b>1.75 x .75 (.093/.062) Railing Channel x 24'</b> 13-63-264 wt/ft: 0.330 6063-T5 Receives .750 picket;</p> 	<p><b>2 x 1 (.093/.056) Railing Channel x 25'</b> 13-63-266 wt/ft: 0.395 6063-T5 Receives .750 picket; Mates with 13-63-227</p> 	<p><b>2 x 1 (.090/.056) Railing Channel x 25'</b> 13-63-267 wt/ft: 0.395 6063-T5 Receives 1" picket; Mates with 13-63-227</p>  <p><b>Accepts Casting:</b> Wall Mount #15: 21-00-190</p>
<p><b>1.5" Railing Channel Cover Plate x 20'</b> 13-63-305 wt/ft: 0.146 6063-T5 Mates with 13-63-300</p> 	<p><b>2" Railing Channel Cover Plate x 16'</b> 13-63-227 wt/ft: 0.175 6063-T5 Mates with 13-63-266 &amp; 13-63-267</p> 	<p><b>2 x 7/16 x .093 Railing Channel x 25' 2"</b> 13-63-261 wt/ft: 0.294 6063-T5 No Legs</p> 	<p><b>2 x .75 (.125/.093) Railing Channel x 23' 10"</b> 13-63-262 wt/ft: 0.440 6063-T5 No Legs</p> 
<p><b>2 x 1 x .125 Channel x 20'</b> 13-63-265 <b>13-63-274</b> x 24' wt/ft: 0.563 6063-T5</p> 	<p><b>2 x 1 Mid Rail Tube x 24'</b> 52-63-11317 wt/ft: 0.858 6063-T52</p>  <p><b>Accepts Casting:</b> Wall Mount #15: 21-00-190</p>	<p><b>2.252 x 1.280 Outside Sleeve x 12'</b> 52-63-4808 wt/ft: 0.562 6063-T6 Sleeves 2 x 1 Channel and Rectangular Tube</p> 	<p><b>2 x 2 x .125 Channel x 20'</b> 13-63-272 wt/ft: 0.861 6063-T5</p> 

## Pre-Punched Arch Aluminum Railing Channel (Mill Finish 6063-T5)

Stock Code	Size in Inches	Picket
13-63-265P	2 x 1 x .125 x 20'	3/4"
13-63-266P*	2 x 1 x .093/.056 x 25'	3/4"
13-63-26620P*	2 x 1 x .093/.056 x 20'	3/4"
13-63-265PR**	2 x 1 x .125 x 24'	3/4"
13-63-266PR**	2 x 1 x .093/.056 x 25'	3/4"
13-63-274PP	2 x 1 x .125 x 24'	1"
13-63-274PPR**	2 x 1 x .125 x 24'	1"
13-63-26720P*	2 x 1 x .093/.056 x 20'	1"
13-63-267P*	2 x 1 x .093/.056 x 25'	1"

\*with welding legs \*\*for pickets with radius corners

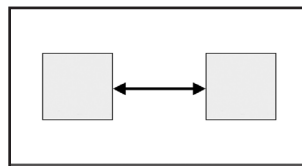

3.75" spacing between holes inside edge to inside edge

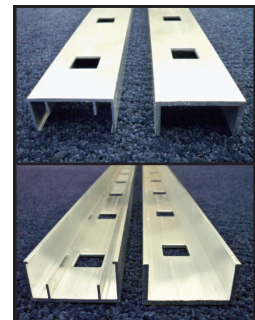

## Picket Spears

19-63-105PS1	3/4 x .062 x 58"
19-63-105PS2	3/4 x .062 x 70"
19-63-130PS1	1 x .060 x 58"
19-63-130PS2	1 x .060 x 70"

3/4" & 1" Spears

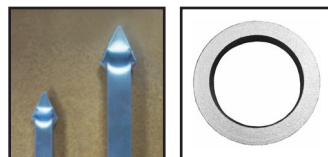

3.75 Decorative Aluminum Rings Casting 21-00-377

Custom sizes and hole locations available as **SPECIAL ORDER**

Mill Order Items: Not in Stock - Custom Sizes & Lengths Available Minimum Order Required

RAILING & FENCE 08



**Eastern Metal Supply** www.easternmetal.com • info@easternmetal.com 06/30/20  
FL: 800-432-2204 • NC/DE/GA: 800-343-8154 • TX/AR: 800-996-6061 • MO/OH: 888-822-6061

# Pipe Brackets (See Standards 21-22 for full selection of Pipe)

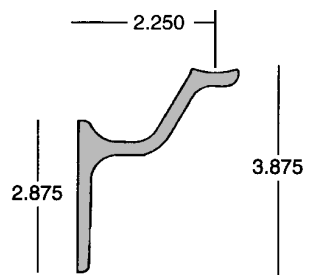
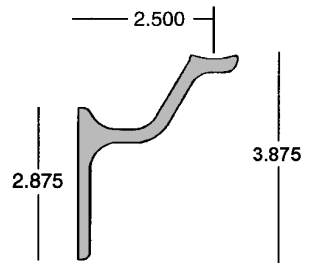

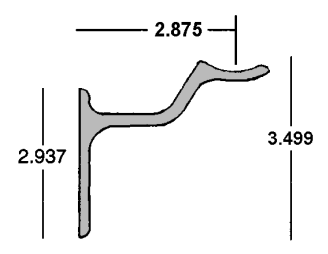
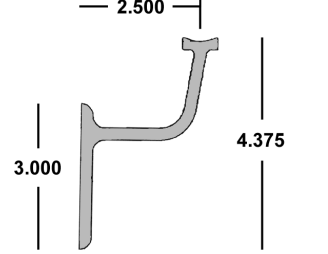
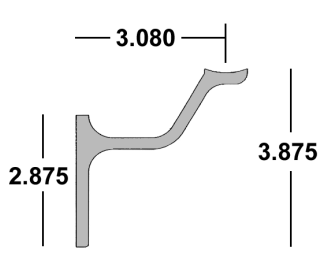
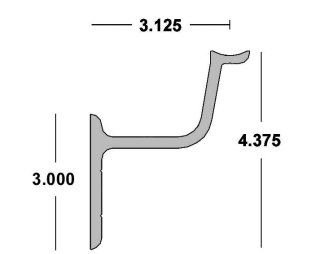
	<p>2.25" x 3.875" Centerline Projected Pipe Bracket x 16' 31-63-135      163 wt/ft: 1.940</p> 	<p>2.50" x 3.875" Centerline Projected Pipe Bracket x 16' 31-63-120      162 wt/ft: 2.012</p> 
---	--	---

<p>2.875" x 3.50" Centerline Projected Pipe Bracket x 16' 31-63-105      160 wt/ft: 1.853</p> 	<p>2.50" x 4.375" Centerline Projected Pipe Bracket x 16' 31-63-140      164 wt/ft: 2.154</p> 	<p>3.080" x 3.875" Centerline Projected Pipe Bracket x 16' 31-61-145      165 wt/ft: 2.1815</p> 	<p>3.125" x 4.375" Centerline Projected Pipe Bracket x 12' 31-61-150      wt/ft: 2.264 Meets NFPA 101 Life Safety Code</p> 
---	---	--	--

**Grip Rail - NEW!**

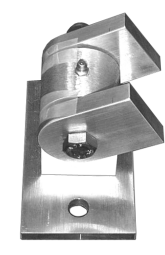

<b>Polished &amp; Anodized</b>	<b>Mill Finish</b>
Stock Code    Description	Stock Code    Description
GR-12    12"	GRM-12    12"
GR-14    14"	GRM-14    14"
GR-18    18"	GRM-18    18"
GR-24    24"	GRM-24    24"
GR-36    36"	GRM-36    36"



<p><b>Mark 5 Gate Hinge*</b> <b>52-63-8793</b> (Heavy Duty) with base plate *up to 800 lb load</p> 	<p><b>Mark 4 Gate Hinge</b> <b>52-63-9150</b> (Heavy Duty) without base plate</p> 
---	---

**SCH 40 Aluminum Pipe End Caps**

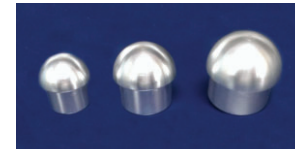
<b>Mill Finish</b>	<b>Pipe Size</b>
APC-100-MF	1
APC-125-MF	1-1/4
APC-150-MF	1-1/2
APC-200-MF	2
<b>Anodized</b>	
APC-750	3/4
APC-100	1
APC-125	1-1/4
APC-150	1-1/2
APC-200	2
<b>Black Plastic</b>	
RN1-1/4DBK1	1

**SCH 40 Pipe x 24' - T4 Temper (for bending)**

<b>Stock Code</b>	<b>Size in Inches</b>
18-63-231	1-1/4 x 1.660 OD x 1.380 ID x .140 Wall
18-T4-500	1-1/2 x 1.900 OD x 1.610 ID x .145 Wall

**Many other Pipe sizes, Alloys & Temper are Available**

**Pipe Inserts (6063-T52)**

18-63-259	1-1/4	SCH 40 x 10'
18-63-260	1-1/2	SCH 40 x 10'
51-00-051	1-3/8	Serrated Tube x 20' (insert for 1-1/4 pipe)

