

INSTALLATION MANUAL

Side-Tie "B"

MODEL

9/12/15/17B-MODEL

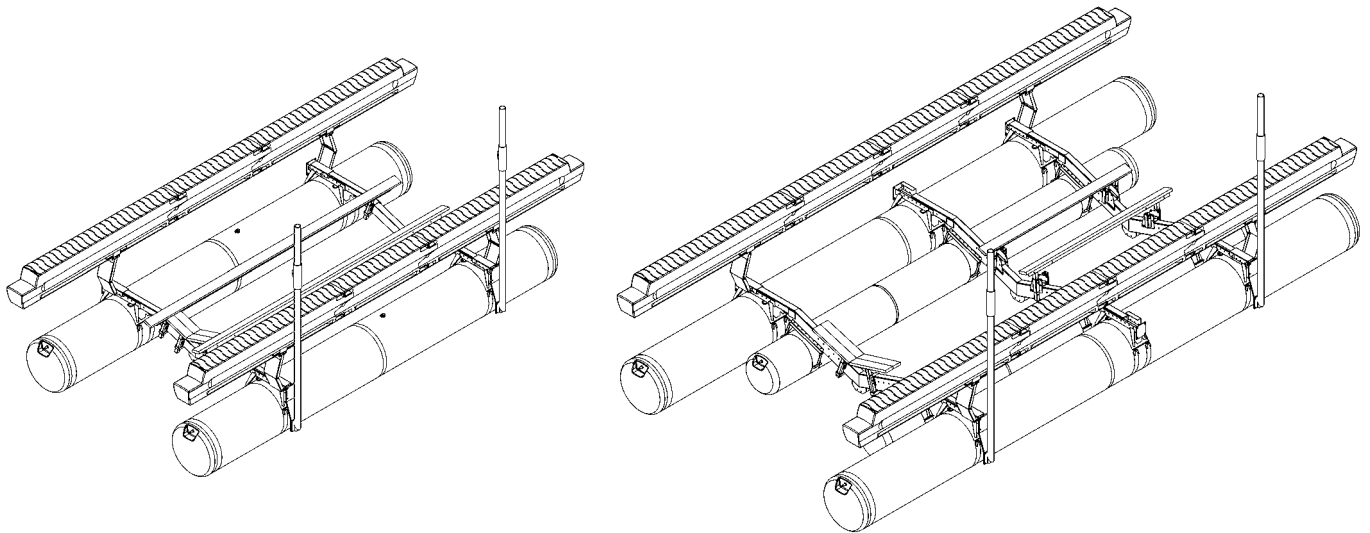

TM

HydroHoist Boat Lifts

HydroHoist International, Inc.
P.O. Box 1286 Claremore, OK USA 74018
1-800-825-3379

Pub. 8/24/04

HydroHoist International, Inc. Product Installation and Use Warning Disclaimer

ASSEMBLY, INSTALLATION OR REPAIRS OF A HYDROHOIST BOATLIFT SHOULD ONLY BE PERFORMED BY AN AUTHORIZED HYDROHOIST TECHNICIAN. IF ASSEMBLY, INSTALLATION AND/OR REPAIR IS PERFORMED BY UNAUTHORIZED PERSONS, SERIOUS PERSONAL INJURY AND/OR PROPERTY DAMAGE COULD OCCUR.

IF UNAUTHORIZED PERSONNEL ASSEMBLE, INSTALL OR REPAIR A HYDROHOIST BOATLIFT, HYDROHOIST INTERNATIONAL, INC. HEREBY DISCLAIMS ANY AND ALL WARRANTIES, EXPRESSED OR IMPLIED. HYDROHOIST INTERNATIONAL, INC., LIMITS ITS WARRANTY TO HYDROHOIST INTERNATIONAL INC.'S PUBLISHED BOATLIFT WARRANTY FURNISHED WITH EACH PRODUCT. NO OTHER WARRANTY OF ANY KIND EITHER VERBAL OR IMPLIED INCLUDING WARRANTIES OF MERCHANTABILITY AND FITNESS FOR A PARTICULAR PURPOSE ARE RECOGNIZED.

THE CONTENTS OF THIS MANUAL ARE SUBJECT TO CHANGE WITHOUT NOTICE AND SHOULD NOT BE CONSTRUED AS A COMMITMENT, REPRESENTATION, WARRANTY OR GUARANTEE OF ANY METHOD, PRODUCT OR DEVICE BY HYDROHOIST INTERNATIONAL, INC.

REPRODUCTION OR TRANSLATION OF ANY PART OF THIS MANUAL, WITHOUT THE WRITTEN PERMISSION OF HYDROHOIST INTERNATIONAL, INC., IS PROHIBITED.

ANY INQUIRIES CONCERNING HYDROHOIST INTERNATIONAL, INC.'S, PUBLISHED WARRANTY OR THIS MANUAL AND ITS CONTENTS SHOULD BE REFERRED TO:

CUSTOMER SERVICE
HYDROHOIST INTERNATIONAL, INC.
915 WEST BLUE STARR DRIVE
CLAREMORE, OK USA 74017
PHONE 918-341-6811
OFFICE HOURS M-F 8AM TO 5PM CT

HydroHoist International, Inc. Safety Notice

TO ENSURE CONSUMER SAFETY, HYDROHOIST INTERNATIONAL, INC., HAS INSTALLED IN THE CONTROL UNIT'S ELECTRICAL SYSTEM AN AC GROUND FAULT CIRCUIT INTERRUPTER (GFCI) DEVICE WHICH IS TO BE USED IN SERIES WITH THE USER'S PRIMARY AC POWER SOURCE. THE GFCI IS AN INTEGRAL PART OF THE HYDROHOIST BOAT LIFT AND IS DESIGNED TO OFFER A LIMITED MEASURE OF PROTECTION TO THE USER AGAINST HAZARDOUS ELECTRICAL CONDITIONS OR SHOCKS SHOULD THEY OCCUR.

THE USER SHOULD BE AWARE OF THE FOLLOWING WARNING:

WARNING!

IF USER DISABLES THE CONTROL UNIT'S GROUND FAULT CIRCUIT INTERRUPTER (GFCI) DEVICE, HE IS IN DIRECT CONFLICT WITH THE RECOMMENDATIONS OF THE UNITED STATES GOVERNMENT CONSUMER PRODUCTS SAFETY COMMISSION. DISABLING THE GFCI COULD RESULT IN SEVERE ELECTRICAL SHOCK OR DEATH.

BEFORE CONNECTING AC POWER TO THE CONTROL UNIT, BE CERTAIN THAT THE PRIMARY AC POWER SUPPLY MEETS ALL APPLICABLE ELECTRICAL CODES.

ANY INQUIRIES CONCERNING THE GROUND FAULT CIRCUIT INTERRUPTER (GFCI) DEVICE SHOULD BE REFERRED TO:

CUSTOMER SERVICE
HYDROHOIST INTERNATIONAL, INC.
915 WEST BLUE STARR DRIVE
CLAREMORE, OK USA 74017
PHONE 918-341-6811
OFFICE HOURS M-F 8AM TO 5PM CT

CONTENTS

Introduction to B-Model

Parts List - *Section 1*

Lift Dimensions - *Section 2*

Assembly Visuals/Exploded - *Section 3*

Getting Started - *Section 4*

Site Preparation & Lift Data Sheet - *Section 5*

Assembly - *Section 6*

Installation - *Section 7*

Final Adjustments - *Section 8*

Trouble Shooting - *Section 9*

Introduction to B-Model

Nomenclature

The first objective when building a HydroHoist B-Model lift is to become acquainted with the different configurations and sizes. An example of the nomenclature of the B-Model lifts would be BL-09-2AF-2T-STD. The descriptions for these abbreviations are as follows.

- BL = Abbreviation for B-Model Lifts
- 09 = Capacity of Lift in 1000's of lbs. B-Models come in 9000,12000,15000,17000 lb capacities
- 2AF = Signifies how many adjustable frames the lift has. B-Models can be 2 or 3 adjustable frames depending on size and hull pad configuration
- 2T = Signifies how many tanks the lift has. B-Models come in 2T and 4T configurations
- STD = Denotes frame width. There is STD = standard. WD = wide, and XWD = extra wide.

Other examples of commonly used abbreviations are:

- HP = Hull Pads

Manual Walkthrough

This Installation Manual will guide you through the steps taken to successfully install a B-Model lift. The illustrations are done in such a way to show how the component being discussed is installed and may not reflect exactly the lift you are installing. For instance, all of the details in Fig C1-2AF-2T-WD Exploded apply to all lifts but the hull support shown is used in 9000 and 12000 B-Models. The illustration in Fig C2-3AF-4T-XWD Exploded show the hull support that is used on 15000 and 17000 B-Models. This is one example of how you will have to be able distinguish which illustrations apply to the lift that you are installing and which illustrations do not. Figures D1-D4 show the most common configurations for each lift to try and clear up any ambiguities that there may be. Also, the optional Centering Guides and Counterweight are left out of the assembly illustrations and are shown at the end of the Section 6-Assembly.

Important Notice

The Tank Band Settings given in this manual are generic. The distances between any frames with hull pads attached must be maintained but freedom is given on 3 frame lifts for the front frame placement if another position better suits the boat. Flexibility is also given for the positioning of the tanks relative to the frames. This dimension should be specific to the boat being lifted. In general a boats center of gravity (Cg) is approximately 1/3 of the total length. So on a 36' boat its Cg would be 12' from the transom. In some cases, such as multiple engine configurations, the Cg is shifted further towards the transom. In these cases the Cg is usually 1/4 of the total length. So a 40' multiple engine boat would have a Cg approximately 10' from the transom. These equations should be applied to the specific boat being lifted and the Tank Band Settings should be adjusted accordingly. On two tank lifts this is easily done by verifying that the center of the tanks is aligned with where the approximate Cg of the boat will be when it is positioned on the lift. The 4T lifts are more difficult but the smaller tanks stay fixed relative to the frames so the outer tanks are the ones that need to be adjusted to fit the boat. The settings given on a 15B are for a boat with a Cg of 8' and the settings given for the 17B are for a boat with a Cg of 9'. Using this information adjust the tank band dimensions "A" accordingly to fit the specific boat being lifted. It is very difficult to adjust this dimension after the lift is installed so be sure to think these steps through before tightening the tank bands.

Parts List

9/12/15/17 B-MODEL PARTS

BL-09-2AF-2T-STD	BL-09-2AF-2T-WD	BL-12-2AF-2T-STD	BL-12-2AF-2T-WD	BL-12-2AF-2T-XWD	BL-12-3AF-2T-STD	BL-12-3AF-2T-WD	BL-12-3AF-2T-XWD	BL-15-3AF-2T-WD	BL-15-3AF-2T-XWD	BL-15-3AF-4T-WD	BL-15-3AF-4T-XWD	BL-17-3AF-4T-WD	BL-17-3AF-4T-XWD
------------------	-----------------	------------------	-----------------	------------------	------------------	-----------------	------------------	-----------------	------------------	-----------------	------------------	-----------------	------------------

TANKS

1A	5014800	TANK ASSY - 32"X23'B	2	2									
1B	5014201	TANK ASSY - 32"X32'B			2	2	2	2	2	2	2	2	2
1C	5012600	TANK ASSY - 32"X38'B							2	2			
2A	5010310	TANK ASSY - 24"X23'B										2	2
2B	5010200	TANK ASSY - 24"X16'A								2	2		

HULL PAD

3A	4260055	16' HULL PADS	2	2									
3B	4260060	20' HULL PADS			2	2	2						
3C	4270060	9' HD HULL PADS					2	2	2	2	2	2	2

V BRACKET

4A	4260035	V BRACKET - TUBE SUPT	1	1	1	1							
4B	4667200	V BRACKET - 20/30B					1	1	1	1	1	1	1

HULL SUPPORT

5	4260045	TUBE - UPPER 2" TUBE	6	6	6	6	6	6	6	6	6	6	6
6	4270160	PAD MOUNT - RECIEVER	4	4	4	4	4	4	4	4	4	4	4
7	4660160	PAD SUPPORT - LOWER ASSY	6	6	6	6	6	6	6	2	2	2	2
8A	4660150	PAD SUPPORT - UPPER ASSY (STD,WD)	6	6	6	6	6	6	2	2	2	2	2
8B	4660130	PAD SUPPORT - UPPER ASSY (XWD)				6			6	2	2	2	2
8C	4270071	WELDMENT - PAD MOUNT							4	4	4	4	4
8D	4270072	WELDMENT - PAD MOUNT - OPP							4	4	4	4	4
9	4270073	WELDMENT - BRACE							4	4	4	4	4

TANK BANDS

10A	4660700	TANK BAND - BIG B LOWER	8	8	8	8	12	12	12	12	12	12	12
11A	4666700	TANK BAND - BIG B UPPER	4	4	4	4	6	6	6	6	6	6	6
10B	3056200	TANK BAND - 24" LOWER										4	4
11B	4050100	TANK BAND - 24" UPPER										4	4

FRAME COMPONENTS

12A	4665600	ADJUSTABLE FRAME CENTER STD	2	2		3							
12B	4665900	ADJUSTABLE FRAME CENTER WD		2	2		3		3	3		3	
12C	4668600	ADJUSTABLE FRAME CENTER XWD				2		3	3	3		3	

WALKWAY COMPONENTS

13	2810000	WALKWAY 10' MODULE	4	4	4	4	4	4	4	4	4	4	4
14	2815000	WALKWAY 5' MODULE	2	2	4	4	4	4	4	4	4	4	4
15	4812095	HINGE BASE - UNIV BIG B	4	4	4	4	4	4	4	4	4	4	4
16	4812060	HINGE ASSY WALKWAY	4	4	4	4	4	4	4	4	4	4	4
17	4812025	HINGE GRIP ASSY	8	8	8	8	8	8	8	8	8	8	8
18	4812030	HINGE GRIP BRACE	4	4	4	4	4	4	4	4	4	4	4
19	4812070	HINGE PIN 10 1/2"	8	8	8	8	8	8	8	8	8	8	8
20	4812085	WALKWAY SPACER - 3FRAME					2	2	2	2	2	2	2

MOORING COMPONENTS

21	4666100	EURO MOORING ASSY	2	2	2	2	2	2	2	2	2	2	2
22	4666150	EURO MOORING COVER - BIG B	2	2	2	2	2	2	2	2	2	2	2
23	4669165	EURO MOORING SLIDER	2	2	2	2	2	2	2	2	2	2	2

CONTROL UNIT

24	3550028	CONTROL UNIT - 4V-2M (PLASTIC MAN.)	1	1	1	1	1	1	1	1	1	1	1
----	---------	-------------------------------------	---	---	---	---	---	---	---	---	---	---	---

HOSE

25	3072502	HOSE 75'	1	1	1	1	1	1	1	1	1	1	1
	3072504	HOSE 10'									1	1	1
	3072507	HOSE 40'	1	1	1	1	1	1	1	1	1	1	1

PARTS BAGS

	6921652	PARTS BAG - 2FRAME LP	1	1									
	6921751	PARTS BAG - 12B			1	1	1	1	1				
	6921752	PARTS BAG - 15B 2T							1	1			
	6921753	PARTS BAG - 15B 4T									1	1	
	6921754	PARTS BAG - 17B											1
	6921850	PARTS BAG - BIG B - XWD											1
	6937500	PARTS BAG - CABLE ASSY 9/12/15/20	1	1	1	1	1	1	1	1	1	1	1
	6937100	PARTS BAG - WALKWAY 45/75/9											
	6937200	PARTS BAG - WALKWAY 12/15/17	1	1									
	6937225	PARTS BAG - WALKWAY 12B 2 FRAME			1	1	1						

Parts List

OPTIONAL CENTERING GUIDE COMPONENTS

26	4668090	CENTERING GUIDE - LH	2	2	2	2	2	2	2	2	2	2	2	2	2	2
	4668095	CENTERING GUIDE - RH	2	2	2	2	2	2	2	2	2	2	2	2	2	2
27	5027802	COVER - 9' CENTERING GUIDE	4	4	4	4	4	4	4	4	4	4	4	4	4	4

Lift Dimensions

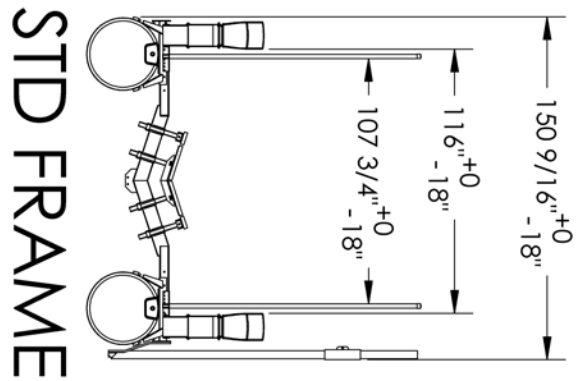
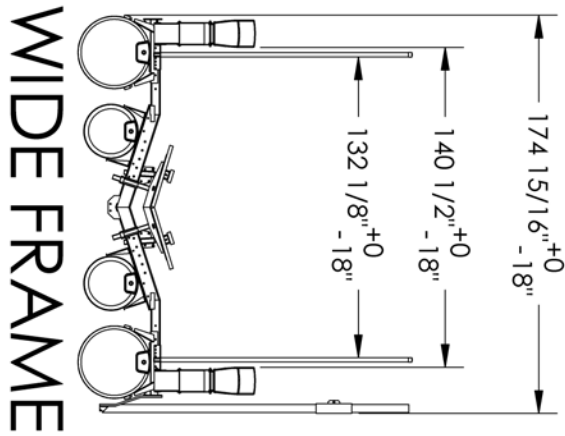
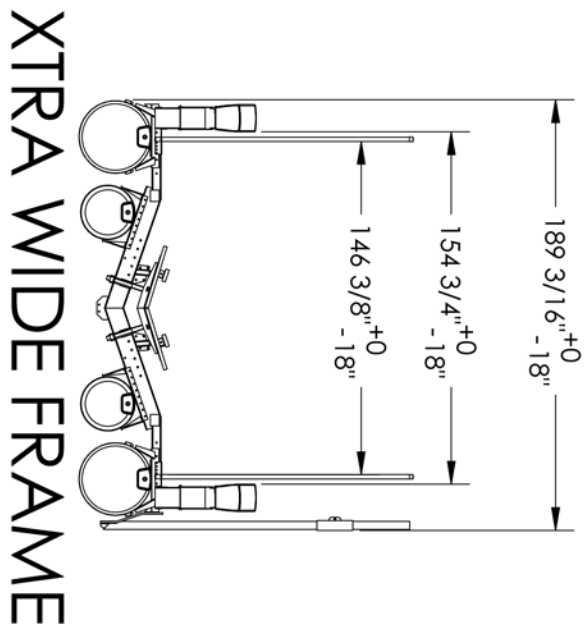
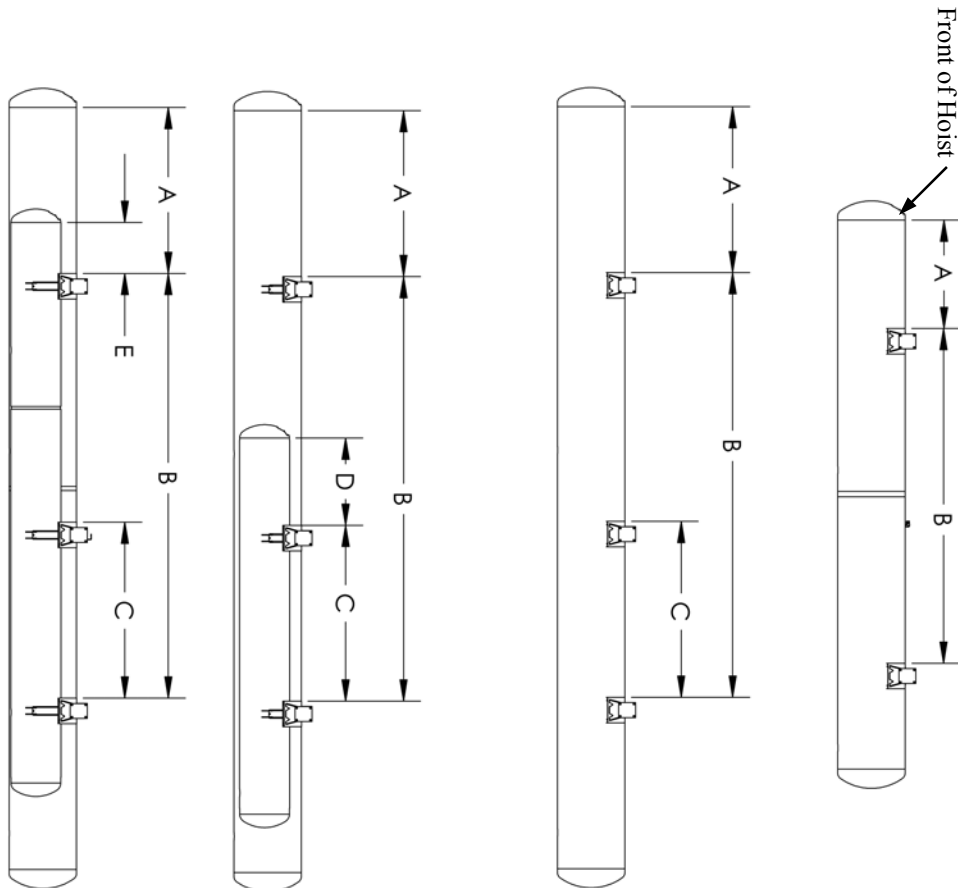

Fig. A



Lift Dimensions



SIZE	TANKS	#/TANKS	#FRAMES	A	B	C	D	E
9	32"x32"	2	2	51"	157 1/4"	X	X	X
12	32"x32"	2	2	78"	199 1/2"	X	X	X

SIZE	TANKS	#/TANKS	#FRAMES	A	B	C	D	E
12	32"x32"	2	3	78"	199 1/2"	82 5/8"	X	X
15	32"x38"	2	3	102"	199 1/2"	82 5/8"	X	X

SIZE	TANKS	#/TANKS	#FRAMES	A	B	C	D	E
15	32"x32"	4	3	78"	199 1/2"	82 5/8"	41"	X

SIZE	TANKS	#/TANKS	#FRAMES	A	B	C	D	E
17	32"x32" 24"x23"	4	3	78"	199 1/2"	82 5/8"	X	24"

Fig. B

Assembly Visuals

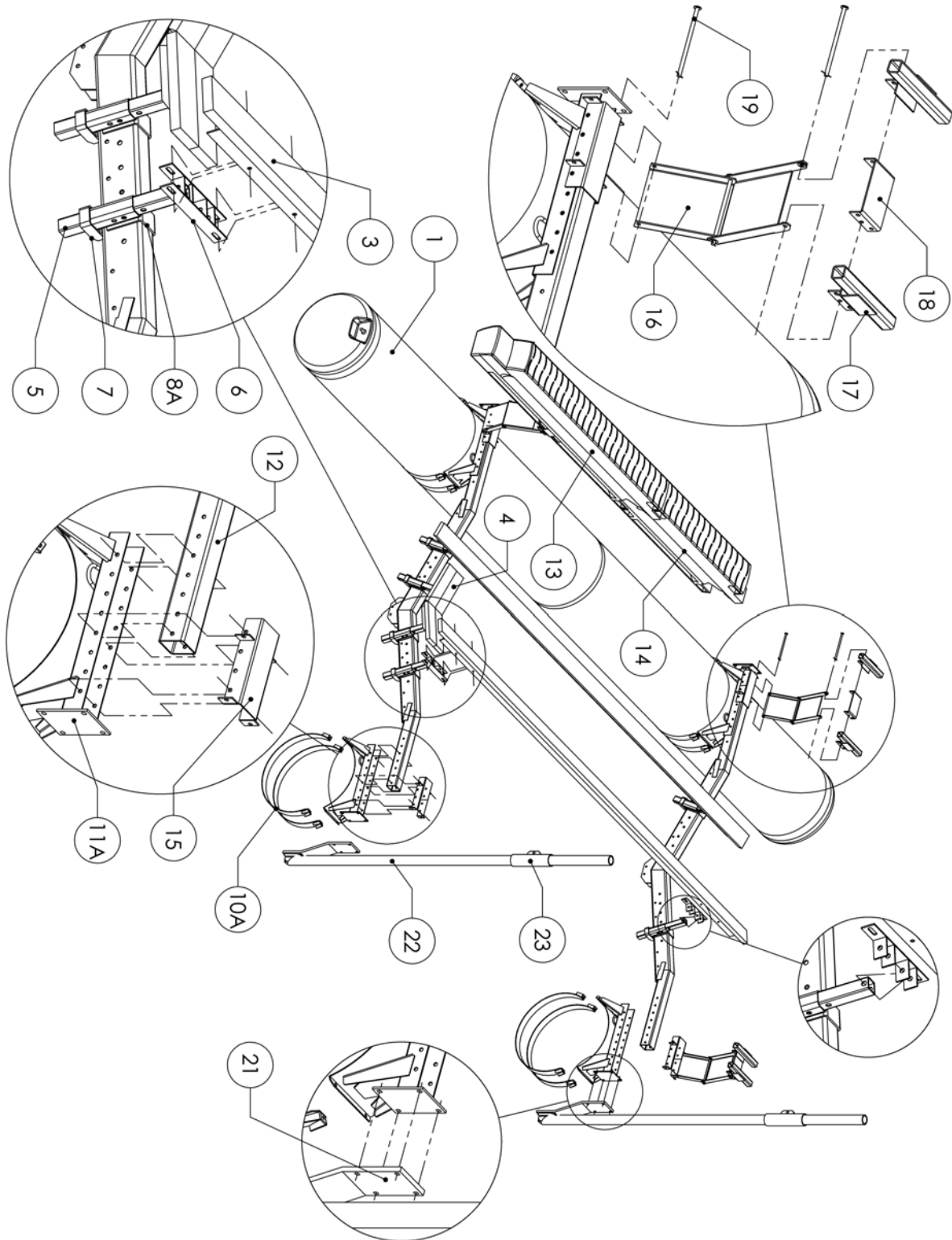

Fig. C1-Exploded-2AF-2T-WD

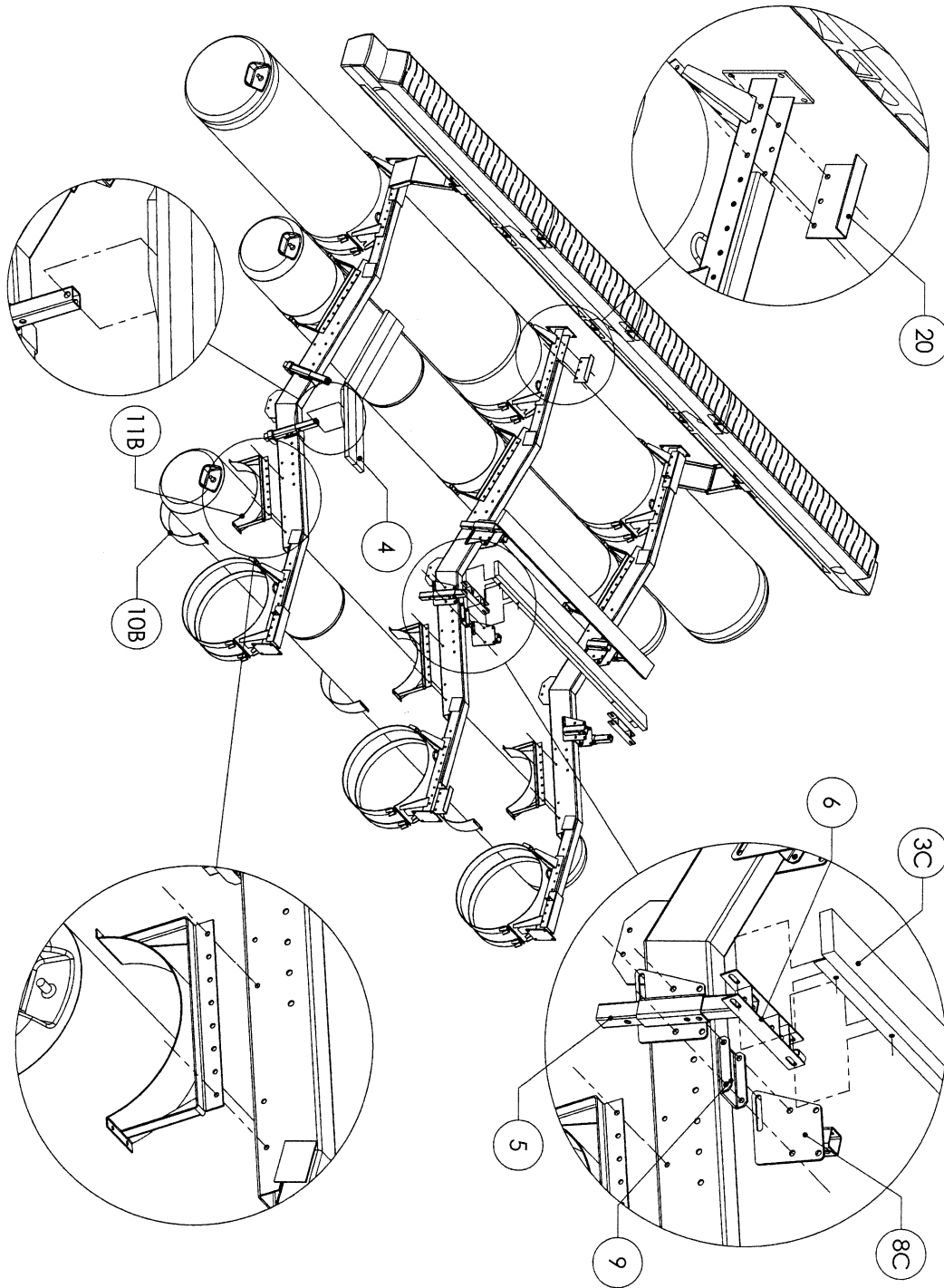
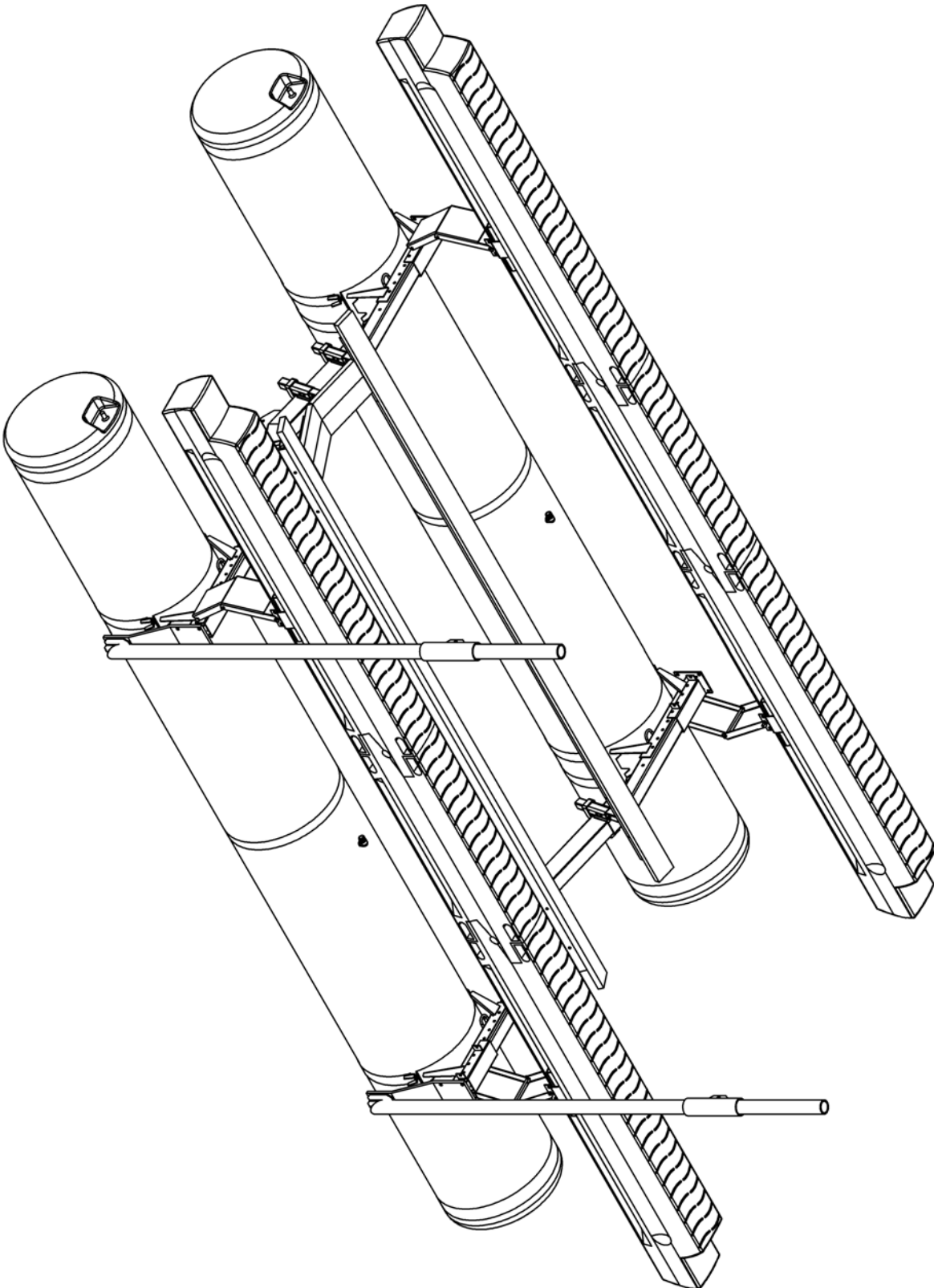
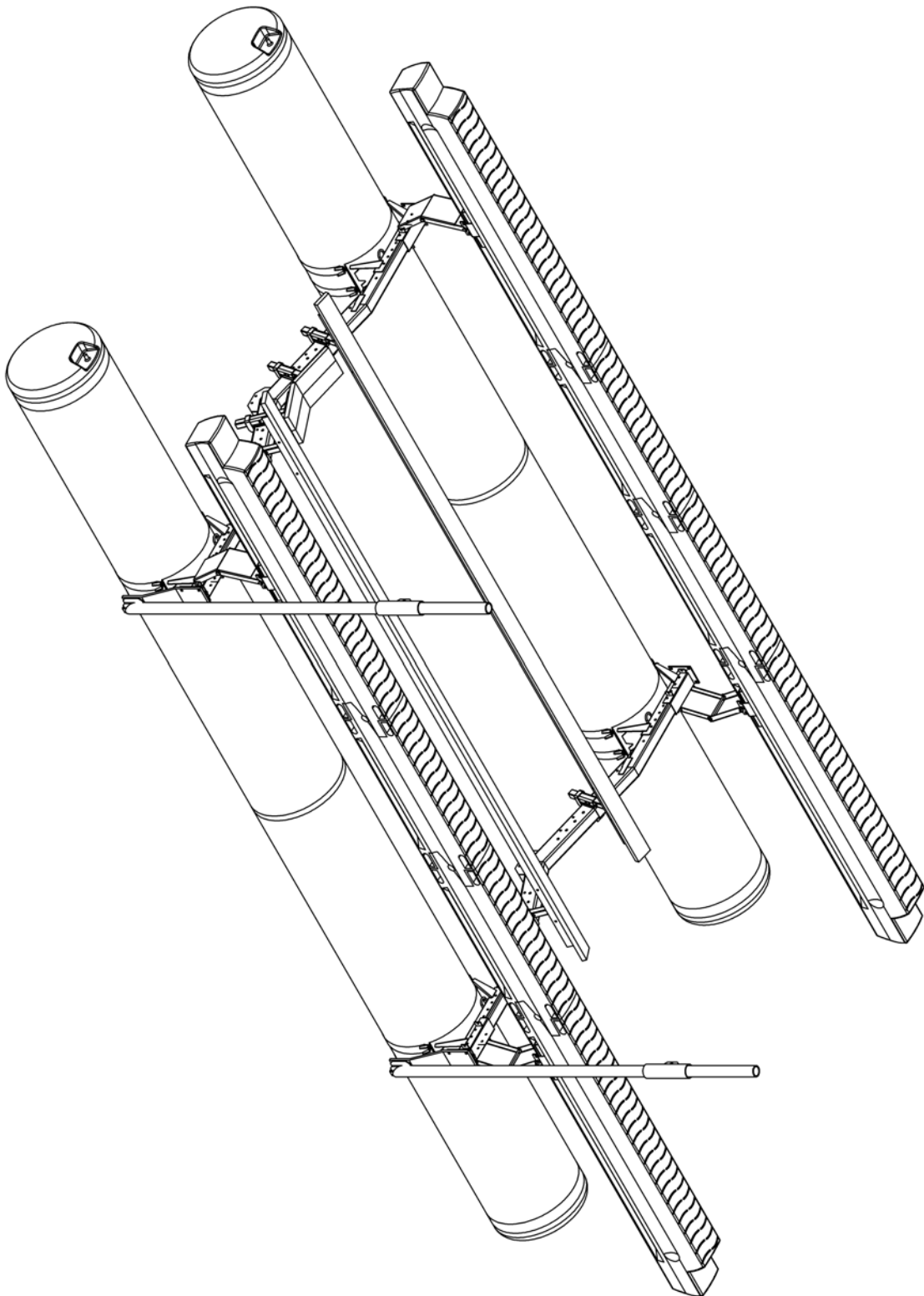

Fig. C2-Exploded-3AF-4T-XWD



- Notes:
1. Comes in STD and WD frames.
 2. Only lift that uses the 16' Hull Pads [3A]
 3. Only lift that uses only 1-5' walkway module [14]

Fig. D1-BL-09-2AF-2T-STD



- Notes:
1. Comes in STD, WD and XWD frames.
 2. Comes in 2AF and 3AF
 3. Uses 20' Hull Pads [3B] on 2AF and 9' Hull Pads [3C] on 3AF
 4. Hull Support Columns are the same for 2AF and 3AF [7.8A/B]
 5. 2AF Lifts use V-Brkt (4A), 3AF Lifts use V-Brkt (4B)

Fig. D2-BL-12-2AF-2T-WD

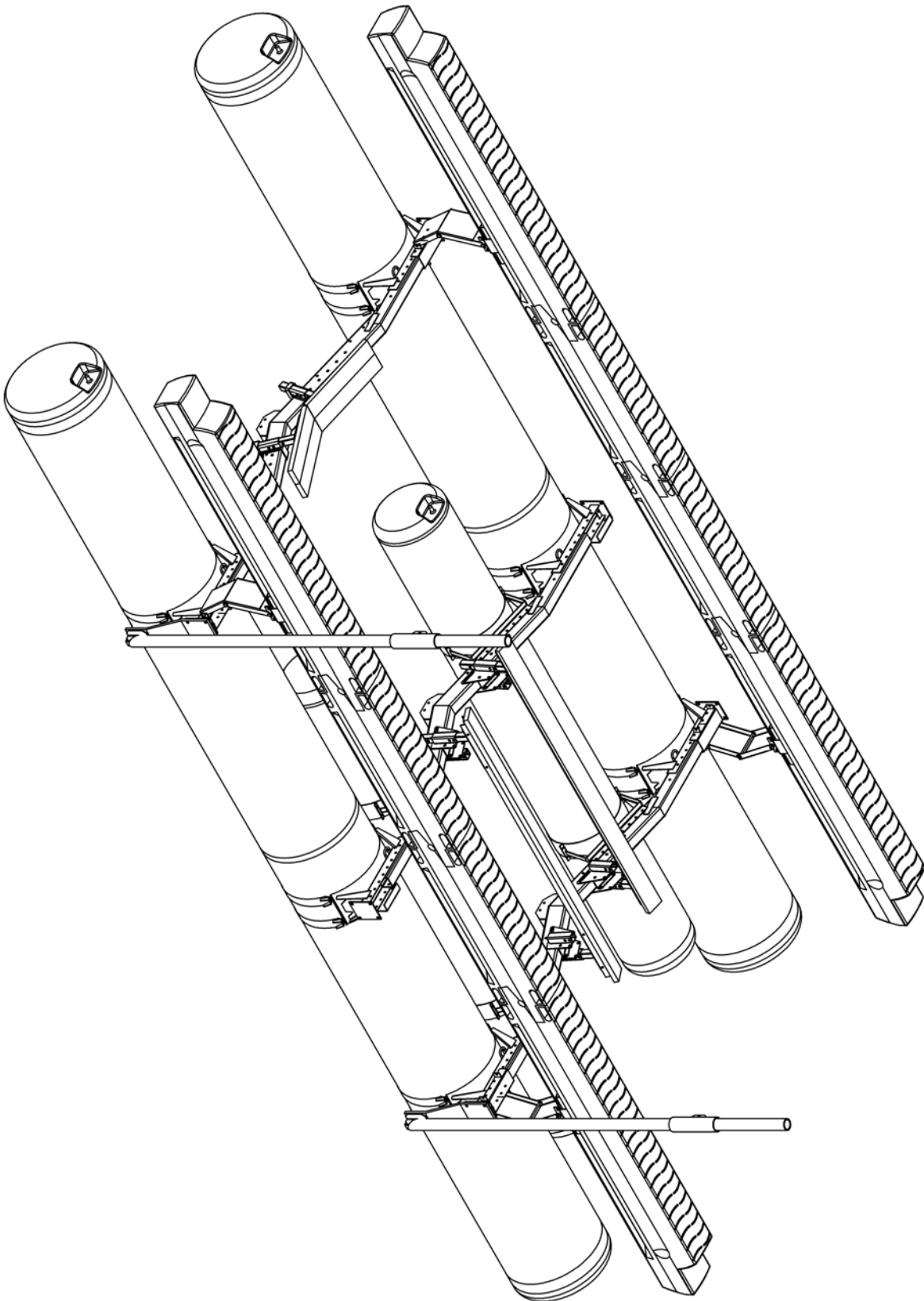
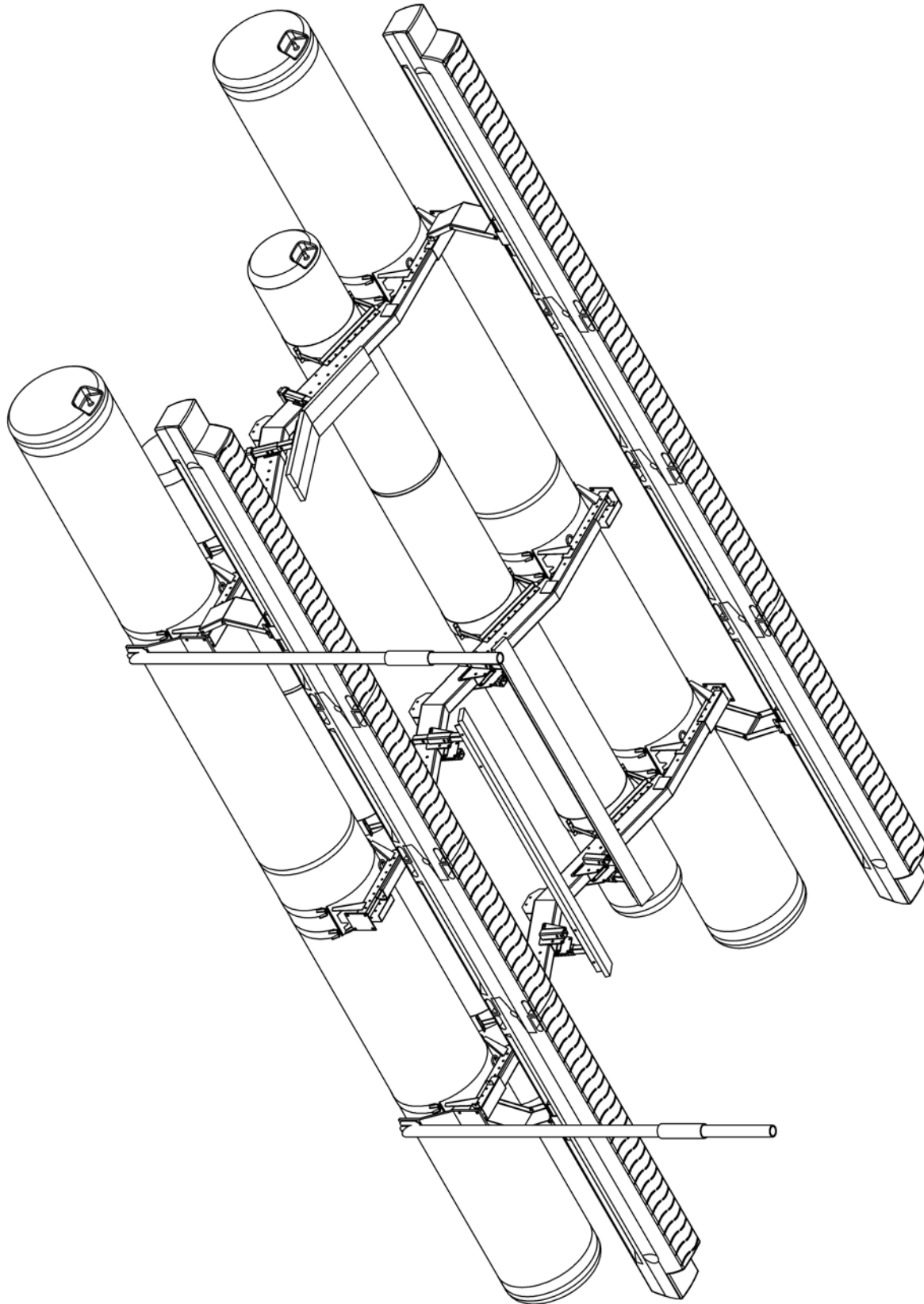

Fig. D3-BL-15-3-AF-4T-WD

Notes:

1. Comes in WD and XWD frames.
2. Comes in 2T and 4T
3. Uses 9' Hull Pads [3C]
4. Hull Support Columns are the same for 2T and 4T [8C/D,9]



- Notes:
1. Comes in WD and XWD frames.
 2. Uses 9' Hull Pads [3C]

Fig. D4-BL-17-3AF-4T-XWD

Getting Started

Assembly Platform

Assembly should be done on a flat, level surface.

A flat-bed trailer with 4x4's across its width is preferred, but a boat trailer with planks across the frame will work, provided that the assembly surface is flat and level. Be sure to have the tanks spaced up off of the surface you are building the lift on to allow for the lower tank bands to be added later.

Tools

A list of tools needed for hoist assembly is given below. In addition to these, tools for boat dock preparation, dock bumper removal, etc., may also be required.

- ◆ 1/2" Drive Ratchet (minimum 9-inch handle length for leverage)
- ◆ Electric Drill
- ◆ 3/4" Deep Well Socket
- ◆ 9/16" Deep Well Socket
- ◆ 5/8" Deep Well Socket
- ◆ 15/16" Deep Well Socket
- ◆ (2) 15/16" Open-end or Combination Wrenches
- ◆ 3/4" Open-end or Combination Wrench
- ◆ 11/16" Open-ended or Combination Wrench
- ◆ 5/16" Nut Runner or medium-blade Slotted Screwdriver
- ◆ Medium Phillips Screwdriver
- ◆ Drift Pin or other hole-aligning tool
- ◆ Large Hammer (3 or 4 lb. shop hammer is best)
- ◆ Knife or tool for cutting 1" rubber hose
- ◆ Measuring Tape

Symbols & Conventions

All references to the LEFT or RIGHT are considered to be facing forward, as if driving a boat into the slip. Left is Port side, Right is Starboard side.

Parts are occasionally described as LEFT or RIGHT to identify their opposing construction, not location on the hoist.

All numbers in brackets [] after part names refer to the item numbers on the assembly illustrations within the manual.

Site Preparation

Verify	The Boat Stall or Mooring Location. <ul style="list-style-type: none">◆ If the hoist is being installed in a commercial marina or multi-slip boat dock, confirm the correct mooring location for hoist and boat.
	The boat specifications. <ul style="list-style-type: none">◆ Make _____◆ Model _____◆ Length _____◆ Beam _____◆ Dry Weight of boat _____ lbs.◆ Fuel: _____ gal. @ 6.6 lbs./gal. = _____ lbs.◆ Water: _____ gal. @ 7.5 lbs./gal. = _____ lbs.◆ Gear estimated @ 8% of boat's dry weight _____ lbs.◆ Other equipment or weight _____ lbs.◆ TOTAL LIFTING WEIGHT _____ LBS.

Inspect	The boat slip, dock or seawall to which the hoist will be installed.
	◆ The structure should be of good, sturdy construction capable of maintaining a secure mooring for the hoist.
	◆ The 9, 12, 15, and 17B require a minimum water depth of 6'6" in which to operate. Confirm that there is sufficient water depth at all times of the year.
	◆ Check for underwater obstructions, such as structural braces, cables, rocks, or sunken objects which will interfere with the hoist's operation.
	◆ Check for overhead obstructions and confirm that sufficient clearance exists for the lifting of the boat.
	◆ Confirm that electrical supply is available and sufficient for hoist operation.
	◆ Confirm that sufficient dock space is available for mooring the hoist and boat.
◆ CONFIRM THE BOAT HULL CONFIGURATION - Boats with a stepped hull design, or with through-the-hull apparatus, may require special positioning or alteration of the Hull Support Pads. Contact HydroHoist Engineering Department if proper hull support is in question.	

Assembly Instructions

Description The assembly instructions presented within this section represent the steps for assembling the Model 9/12/15/17 B-Model HydroHoist Boat Lift. It is recommended that before assembling the components, you read and understand each procedural step to become familiar with how all parts are assembled.

Tightening of Fasteners In the assembly procedures, DO NOT TIGHTEN fasteners until directed to do so. Insert bolts with appropriate washers, lock washers and nuts, but, unless otherwise instructed, leave the fasteners loose to allow movement of the parts for adjustment during assembly. Tighten all bolts at finish of assembly - proper torque specifications for bolts are listed below:

BOLT SIZE	FOOT POUNDS OF TORQUE
1/4-20	5 ft-lbs
5/16-18	11 ft-lbs
3/8-16	18 ft-lbs
7/16-14	28 ft-lbs
1/2-13	39 ft-lbs
9/16-12	51 ft-lbs
5/8-11	83 ft-lbs

Step	Procedure
1.1 Fig. E	Align the Tanks [1] parallel with each other with the Air Injection Nipple to the front of the hoist assembly and in the 12 o'clock position. If building a 4 tank lift position the 24" Tanks [2] in between the 32" Tanks [1] in their approximate position and with the nipple at 12 o'clock.
1.2	Refer to Fig. B for correct tank band locations, and position Tank Bands [11A] onto the tanks [1].
1.3	Place the Frame [12] and the Hinge Base [15] onto Tank Bands [11A] as shown in Fig. E (do not use Hinge Base [15] on middle frame). NOTE: Fig. E shows the maximum allowable width of an assembly. Refer to Fig. A to determine if a narrower width should be used and align the assembly accordingly.
1.4	If building a 3 frame lift Refer to Fig. F and bolt the Walkway Spacer [20] in the outermost holes of the Tank Band [11A] on the middle frame.
1.5	Hand Tighten 1/2" x 6" bolts, nut, and lockwasher in the correct position. Used: 2F = 12-1/2" x 6" bolts 3F = 20-1/2" x 6" bolts

Fig. E

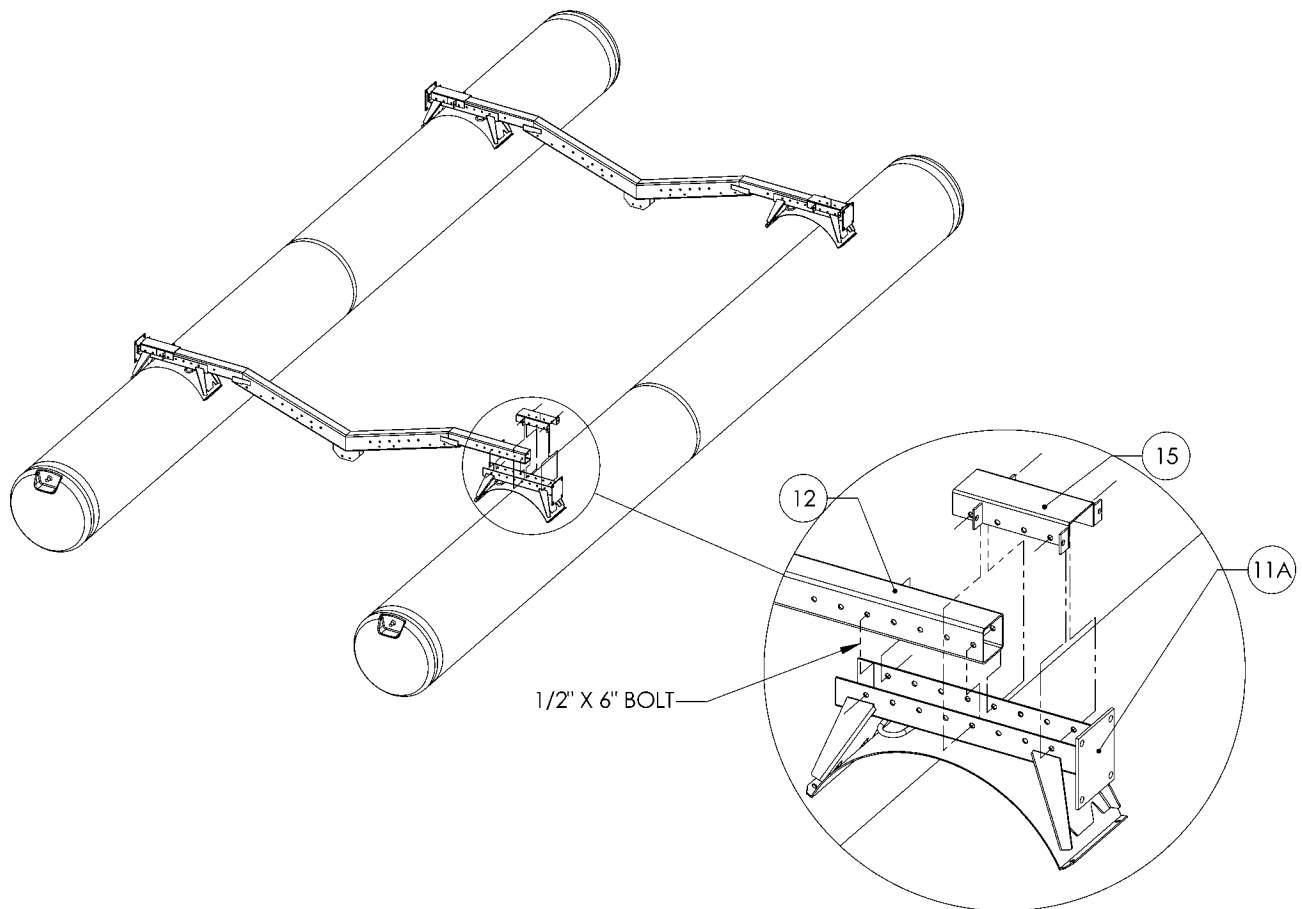

*Inner Tanks
 & Tank Bands*

Step	Procedure
1.6 Fig. F	If building a 4 tank lift bolt the 24" Tank Band [11B] to the Frame [12] with 1/2" x 6" bolts as shown. Used: 15B = 8-1/2" x 6" bolts 17B = 12-1/2" x 6" bolts <i>NOTE: width of the hoist assembly determines which set of holes on the frame are used for these tank bands. If building the assembly in its narrowest possible position, use the inside set of holes.</i>
1.7	Bolt the 24" Lower Tank Bands [10B] to the 24" Tank Bands [11B] using a 7/16" x 2" bolt as shown. DO NOT TIGHTEN Used: 15B = 16-7/16" x 2" bolts 17B = 24-7/16" x 2" bolts

Fig. F

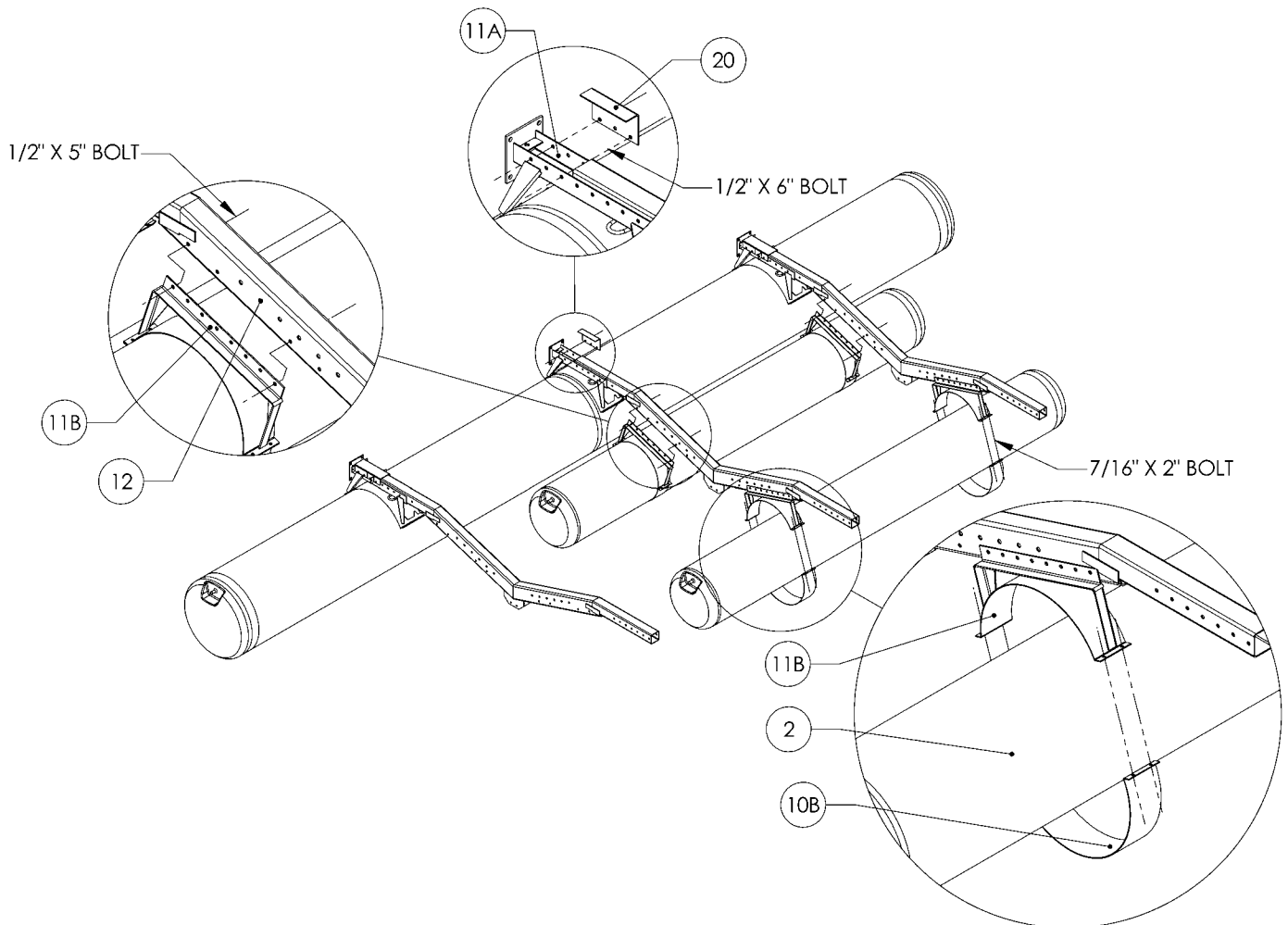

Step	Procedure
2.1	Fig. G1 represents the hull support column assembly for the 9000 and 12000 B-Model and Fig. G2 represents the hull support column assembly for the 15000 and 17000 B-Model. NOTE: All models use the hull support column assembly shown in Fig. G1 for the Vee Bracket assembly on the front frame of the hoist.
2.2 Fig. G1	Place the Upper Pad Support [8A] on the frame in its approximate position with the square tube portion of the part facing the front of the hoist. Bolt the Lower Pad Support [7] to the Upper Pad Support [8A] using a 1/2" x 2 1/2" bolt. Used: 9/12B = 6-1/2" x 2 1/2" bolt 15/17B = 2-1/2" x 2 1/2" bolt
2.3 Fig. G2	Bolt the 2 Pad Mount Weldment [8C/8D] to the frame through the long slotted hole using a 5/8" x 5 1/2" bolt. Position the Weldment Brace [9] in between the 2 Pad Mount Weldments [8C/8D] and bolt using 5/8" x 1 1/2" bolts. Used: 15/17B = 4-5/8" x 5 1/2" bolt 16-5/8" x 1 1/2" bolt
2.4 Fig. G1 Fig. G2	Bolt the Upper 2" Tube [5] to the Pad Mount Weldment [8D] or the Upper Pad Support [8A] using a 5/8" x 3 1/2" bolt. Used: 9/12/15/17B = 6-5/8" x 3 1/2" bolt NOTE: None of these bolts need to be fully tightened at this time.

Fig. G1

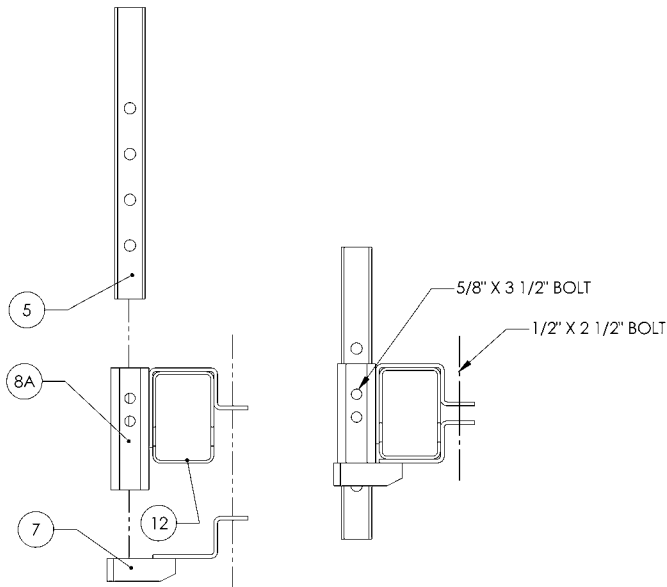
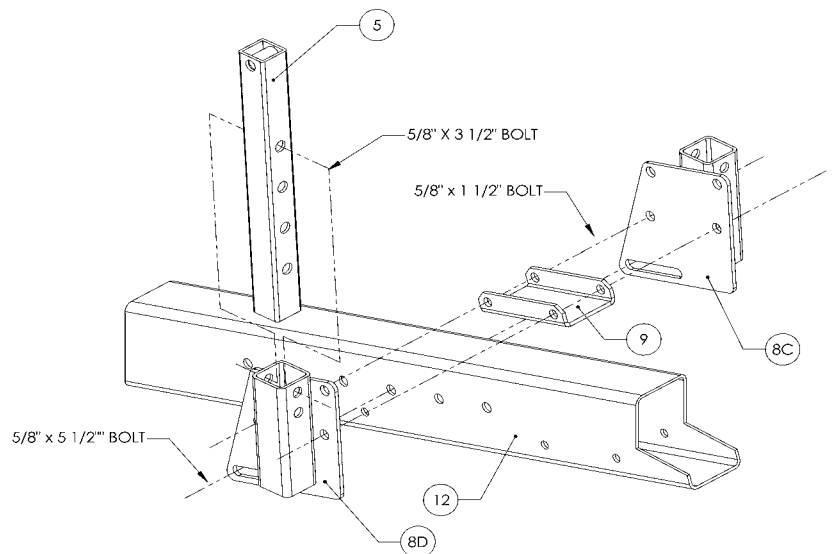

Fig G2



**Hull Pad Support
 System & Hull Pads
 9/12B**

Step	Procedure
3.1A Fig. H	Place the Pad Mount Receiver [6] into the Hull Pads [3] and bolt using a 1/2" x 5" bolt. Used: 9/12B= 16-1/2" x 5" bolts
3.2A	Place the Hull Pads [3] (with the receiver bolted in place) onto the Upper 2" Tube [5] as shown. Bolt the Upper 2" Tube [5] to the Pad Mount Receiver [6] using a 5/8" x 3 1/2" bolt. Used: 9/12B= 4-5/8" x 3 1/2" bolts NOTE: The tank band settings given in Fig. B are correct for the Hull Pad system oriented as shown.

Fig. H

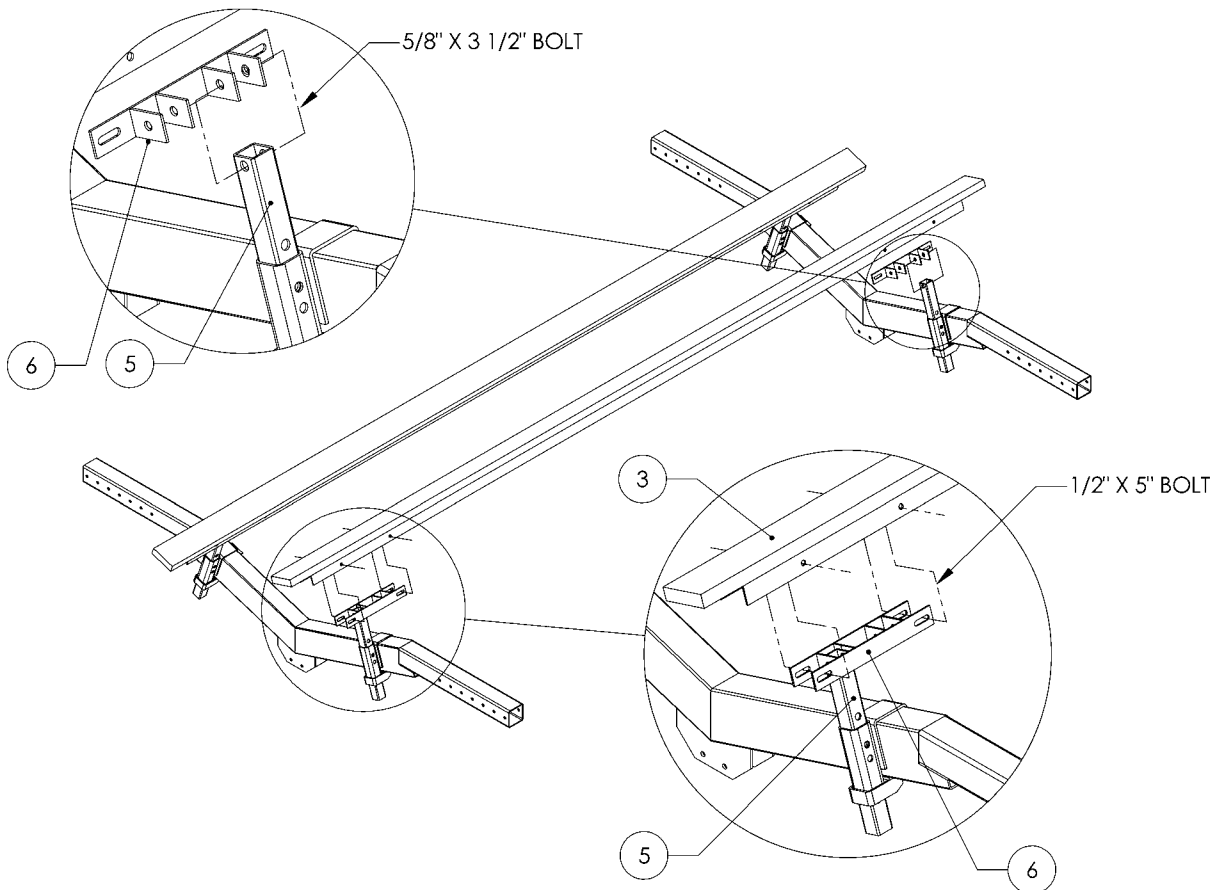

*Hull Pad Support
 System & Hull Pads
 15/17B*

Step	Procedure
3.1B Fig. I	Place the Pad Mount Receiver [6] into the Hull Pads [3] and bolt using a 1/2" x 5" bolt. Used: 15/17B= 16-1/2" x 5" bolts
3.2B	Place the Hull Pads [3] (with the receiver bolted in place) onto the Upper 2" Tube [5] as shown. Bolt the Upper 2" Tube [5] to the Pad Mount Receiver [6] using a 5/8" x 3 1/2" bolt. Used: 15/17B= 4-5/8" x 3 1/2" bolts NOTE: The tank band settings given in Fig. B are correct for the Hull Pad system oriented as shown.

Fig. I

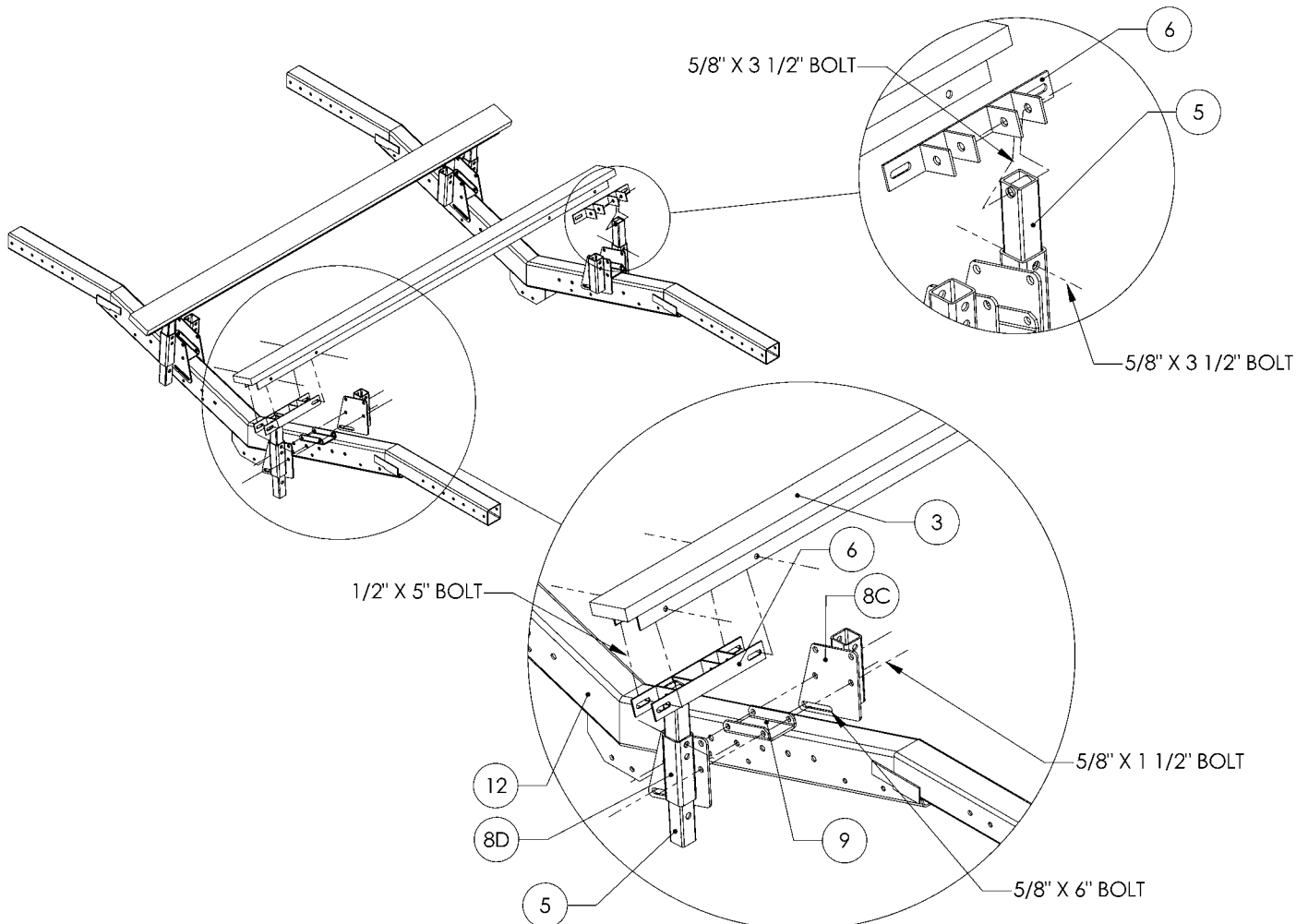

Vee Bracket

Step	Procedure
4.1 Fig. J	Bolt the Vee Bracket [4] to Upper 2" Tube [5] with a 5/8" x 3 1/2" bolt. Used: 2-5/8" x 3 1/2" bolt <i>NOTE: The assembly is the same for Vee Brackets [4A] and [4B].</i>

Fig. J

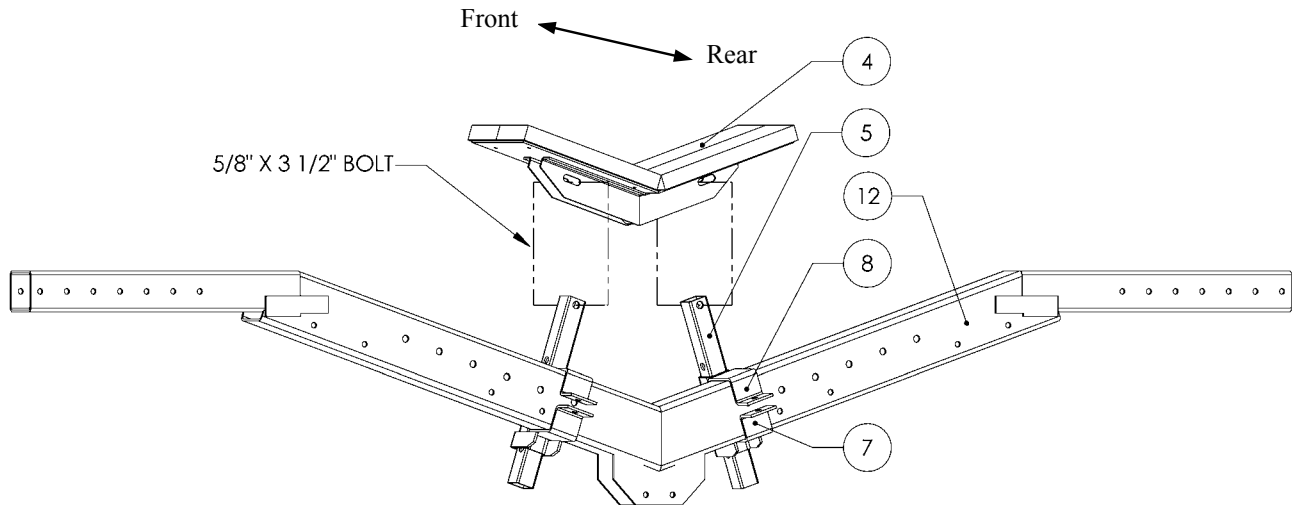

Lower Tank Bands

Step	Procedure
5.1	VERY IMPORTANT: Sight across the frames and verify that the frames are parallel and there is no twisting in the hoist. If the lift is un-level shim underneath the tanks until it is perfectly level. Verify that the tank band settings are still correct and then tighten all of the bolts installed on the hoist to the torque specifications listed on Pg. 1.
5.2 Fig. K	Once the lift is leveled and tightened down apply the tar strips located in the lifts main parts bag to the tank directly under the Upper Tank Bands [11A]. To do this clean the bottom of the tank in this area and place the “tacky” side of the tar strip slowly to the bottom of the Tank [1]. Using a round object (like the 15/16” deep well socket) press hard and slide the object all along the paper on the opposite side of the tar strip. The longer this is done the easier it is to remove the paper from the tar strip. Peel the paper back slowly, making sure to keep the “tar” on the tank. When the paper is removed the Lower Tank Band [10A] can be positioned underneath the Upper Tank band [11A]. Bolt the Lower Tank Band [10A] to the Upper Tank Band [11A] using a 7/16” x 2” bolt. Used: 2AF = 16-7/16” x 2” bolts 3AF = 24-7/16” x 2” bolts

Fig. K

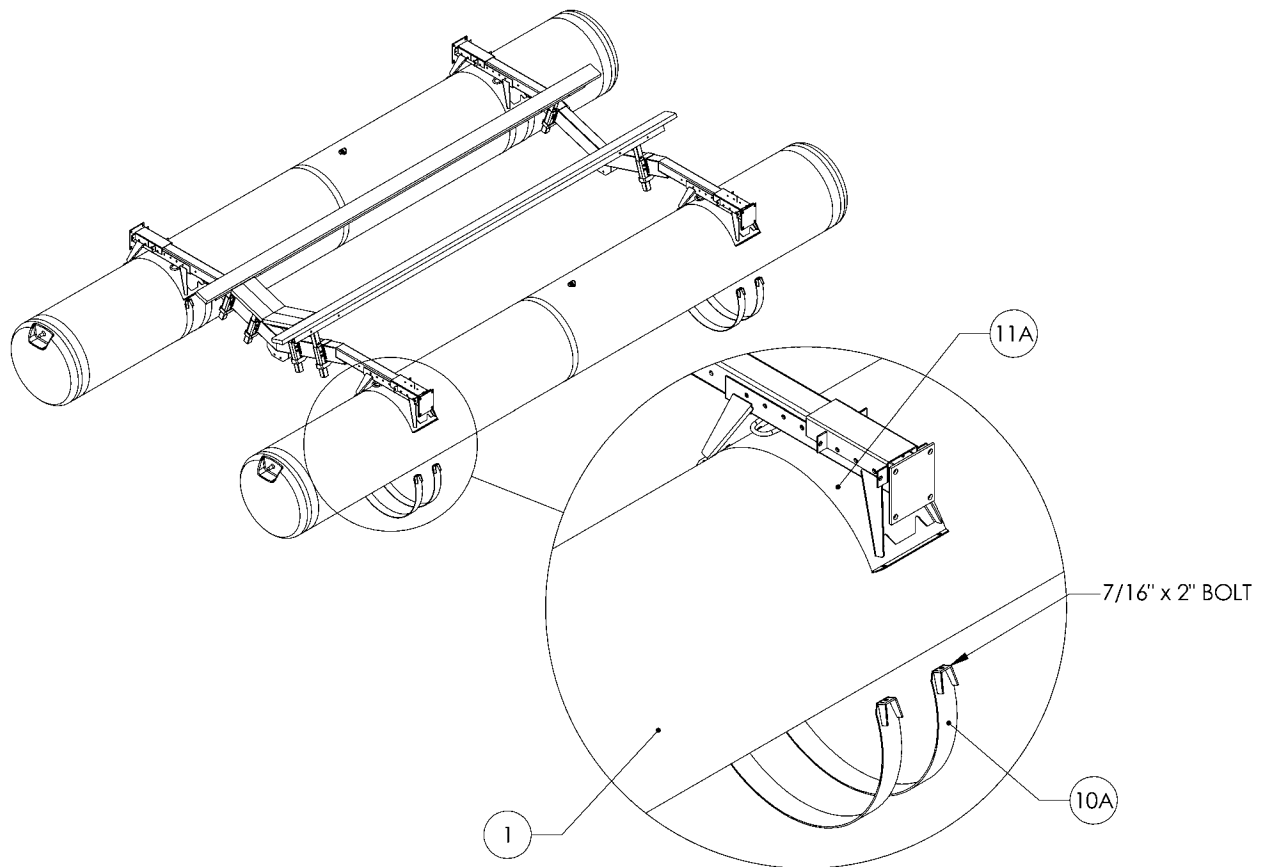

Walkway Assembly

Step	Procedure
6.1 Fig. L	Attach the Hinge Assembly [16] to the Hinge Base [15] using the 10 1/2" Hinge Pin [19] at each corner. Secure using a cotter pin and flat washer in the hole at the tip of the Hinge Pin [19].
6.2 Fig. M	Lay out the Walkway Modules [13/14] top side up with joint ends together on a flat surface. Push the modules together as far as possible by hand. Then use the starter bolt (5/8"x3 1/2") to pull the two modules together. Install the opposite side bolt snugly and replace the "starter bolt" with 5/8" x 2 1/2" galvanized bolt, two flat washers, a lockwasher and a nut each. Be sure to use the Plastic Walkway Spacer (4812075) in between each section on the top of the assembly. This is especially important on two frame lifts when the Walkway Spacer [20] is not used. Leave the bolts snug but not tight. Assemble bolts at each junction in this manner. Do a final alignment of the Modules [13/14] and then tighten all four bolts evenly to 83 FT.LBS. Used: 9B = 16-5/8" X 2 1/2" bolts 12/15/17B = 24-5/8" X 2 1/2" bolts

Fig. L

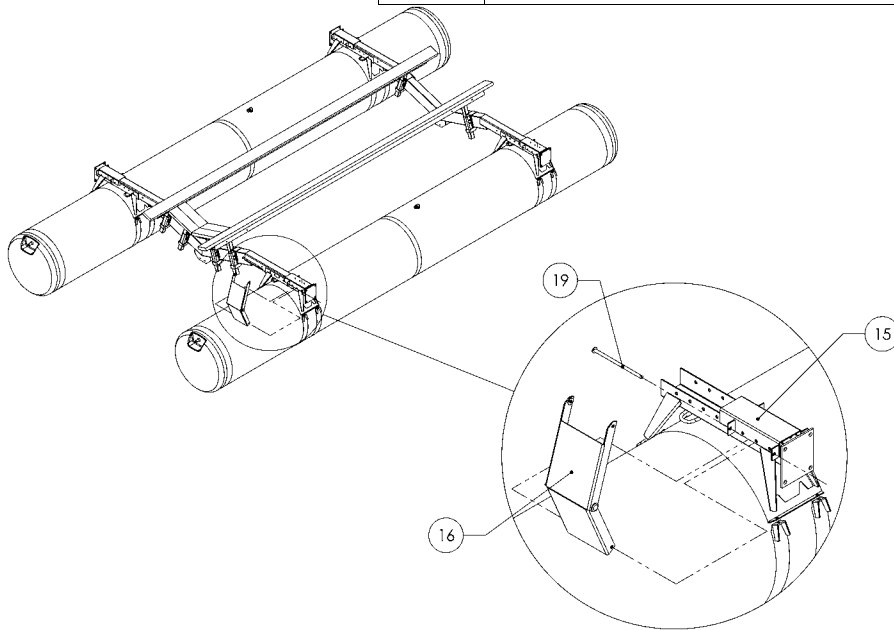
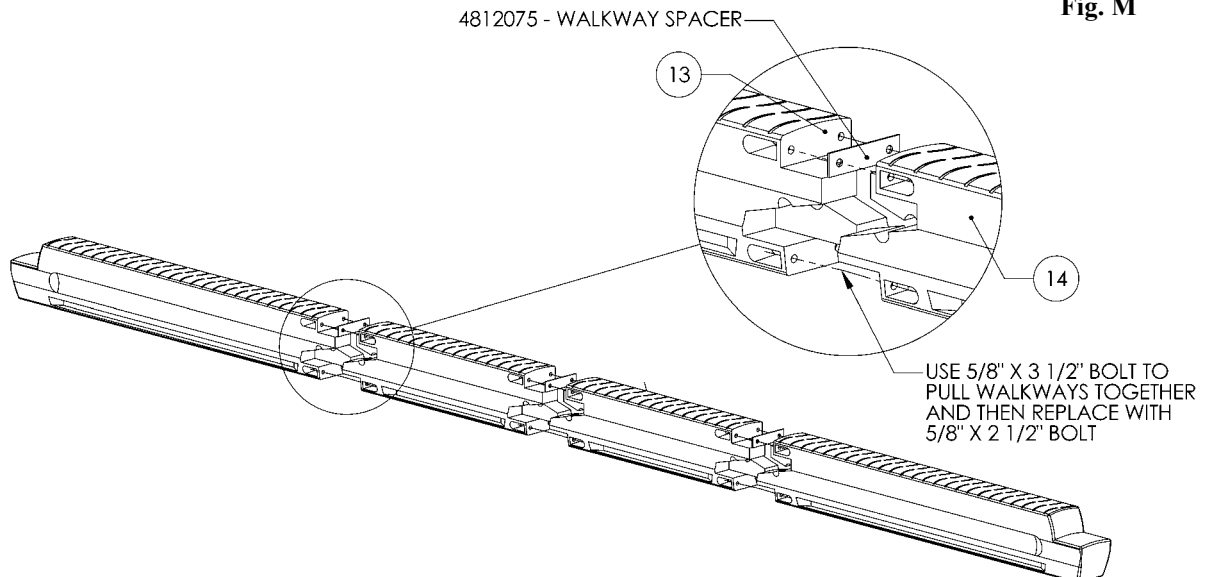

Fig. M



Step	Procedure
6.3 Fig N	Assemble a Hinge Grip Assembly [17] in the grooves 48" from the start of the groove at the front of the walkway assembly. The tubes can be partially set into the groove with a rubber mallet. Loosely bolt the Brace [18] on each side with four 1/2" X 1 1/2" carriage bolts with lock washers and nuts. Evenly draw the Hinge Grip Assembly together and torque the bolts to 39 FT LBS. Fit the opposite Hinge Grip Assembly according to Fig. N. Used: 16-1/2" X 1 1/2" carriage bolts
6.4 Fig O	Turn the Walkway right side up and set it in place on the Lift. Insert a 10 1/2" Hinge Pin [19] in each Hinge Assembly [16] and the Hinge Grip Assembly [17/18] from the inside to the outside and secure with a cotter pin and flat washer.
6.5	Operate the Walkways manually making certain that they can freely travel to the full upright position. If travel is restricted first adjust the distance between the Hinge Grip Assembly.

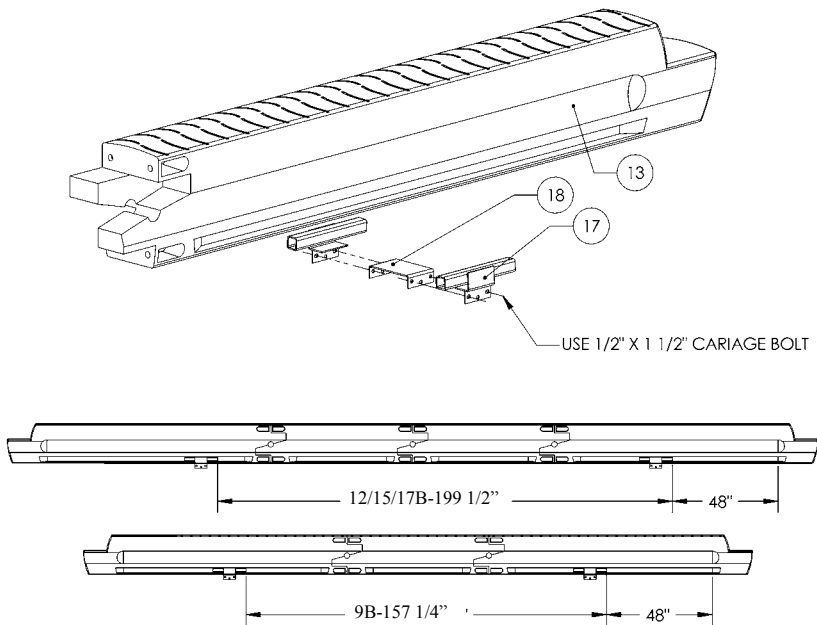
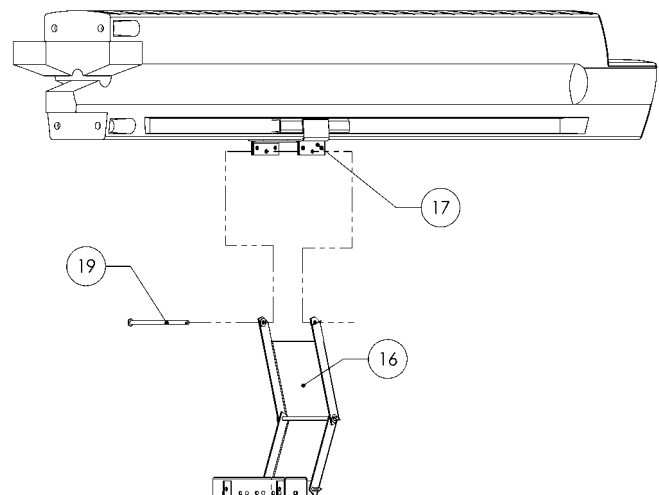
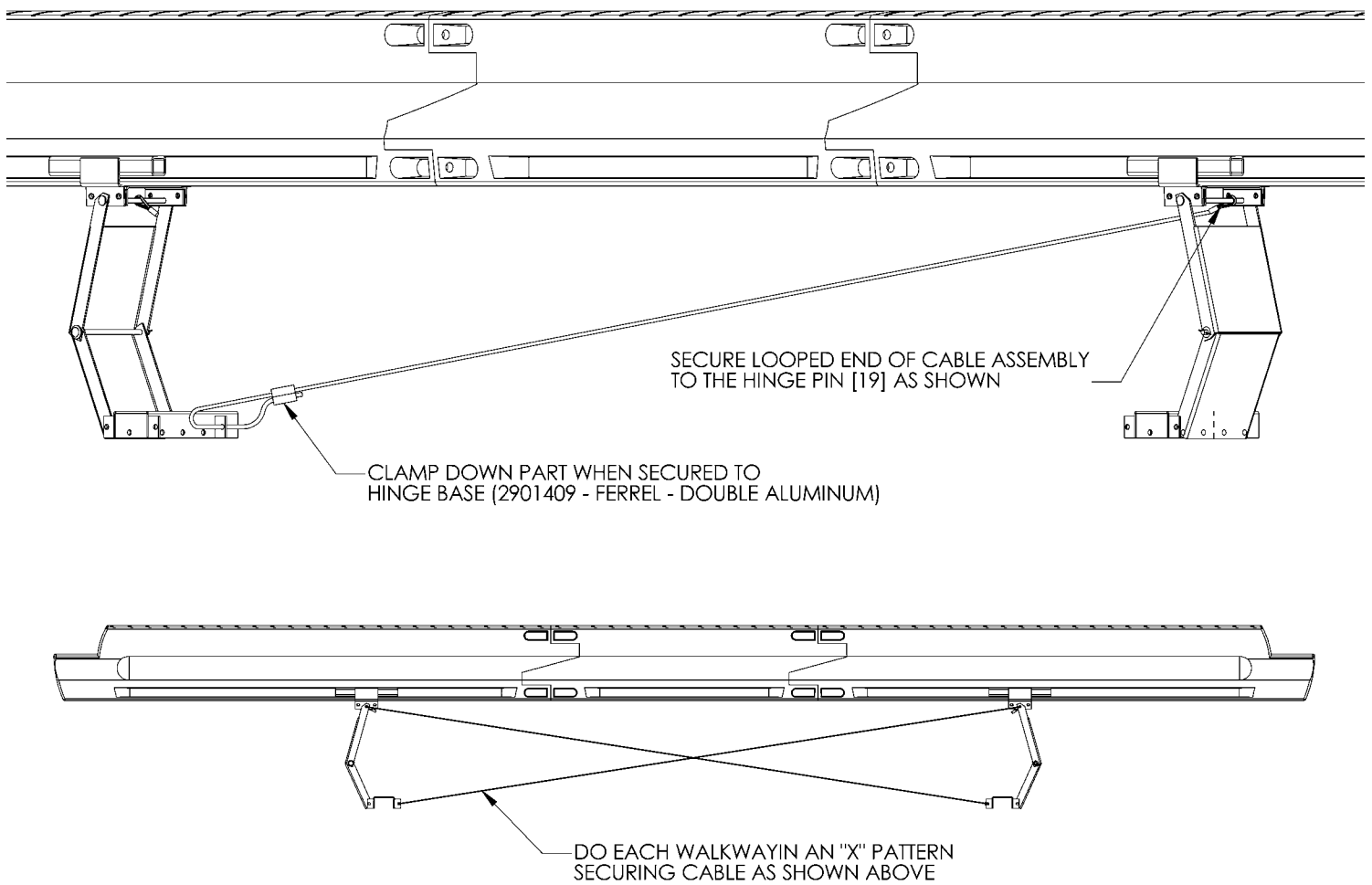

Fig. O



Step	Procedure
6.6 Fig. P	Attach looped end of cable assembly to the Hinge Pin [19] as shown in Fig. P.
6.7	Feed the opposite end of cable into the Hinge Base [15] and secure with the cable clamp found in the parts bag (6937500). Repeat on both walkways.

Fig. P



Centering
Guides

Step	Procedure
7.1 Fig. R	The optional Centering Guides [26] bolt to the tank band assembly in the same way the Hinge Base as shown. A bolt will have to be removed and reinstalled to fit the Centering Guides [26] onto the frame.
7.2	Slide the Cover [27] over the Centering Guide [26].

Fig. R

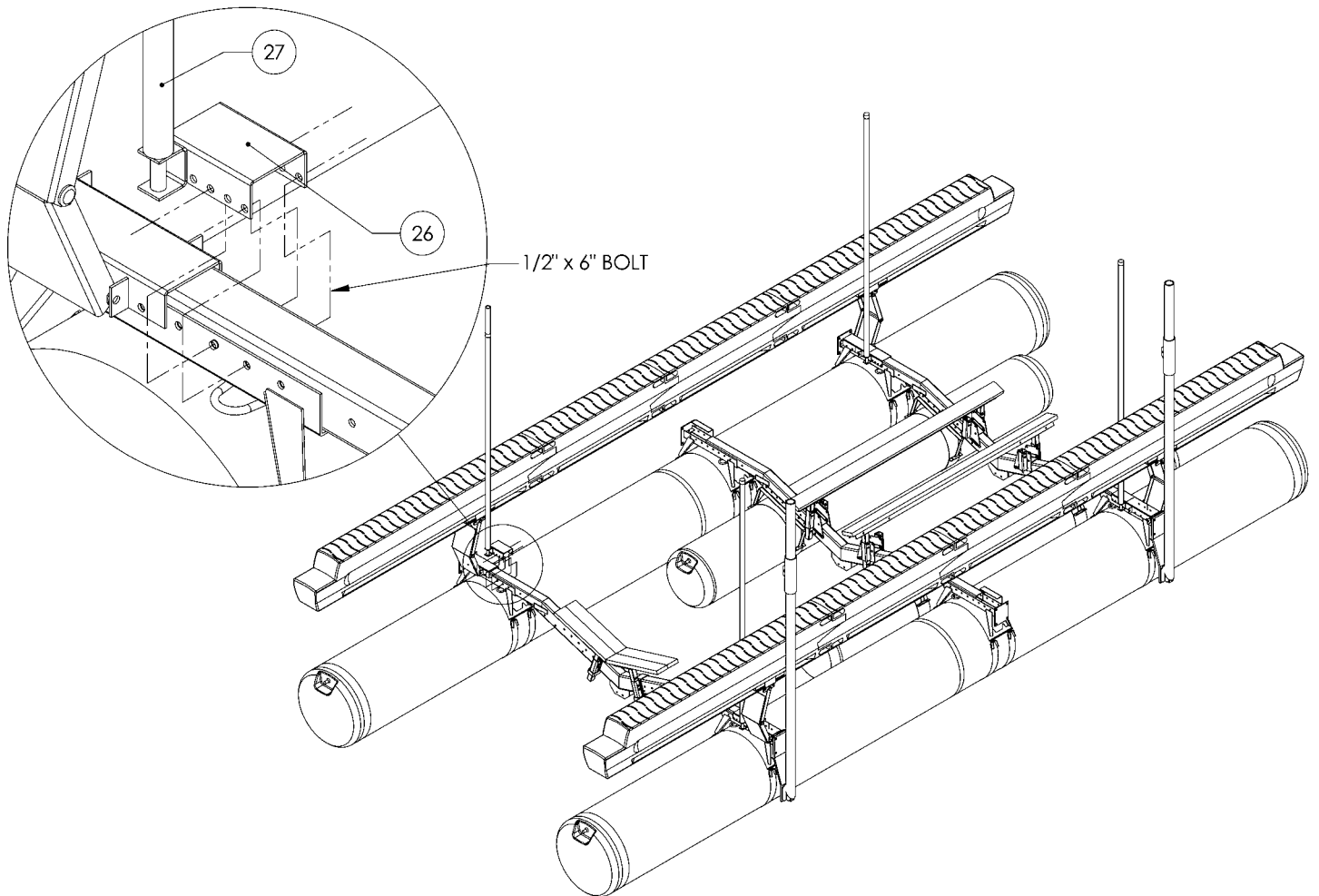

Counterweight

Step	Procedure
8.1 Fig. S	Bolt the Counterweight (4666110) to the end of the Upper Tank Band using the same fasteners as the Mooring. One kit is needed per Mooring Post to help counterbalance the lift (this adds 4" of width to Fig. A).
8.2	Slide the Cover over the Counterweight.

Fig. S

COUNTERWEIGHT - BIG B MODEL - KIT 6022200

1 KIT NEEDED PER MOORING

ADDS 4" TO LIFT WIDTH

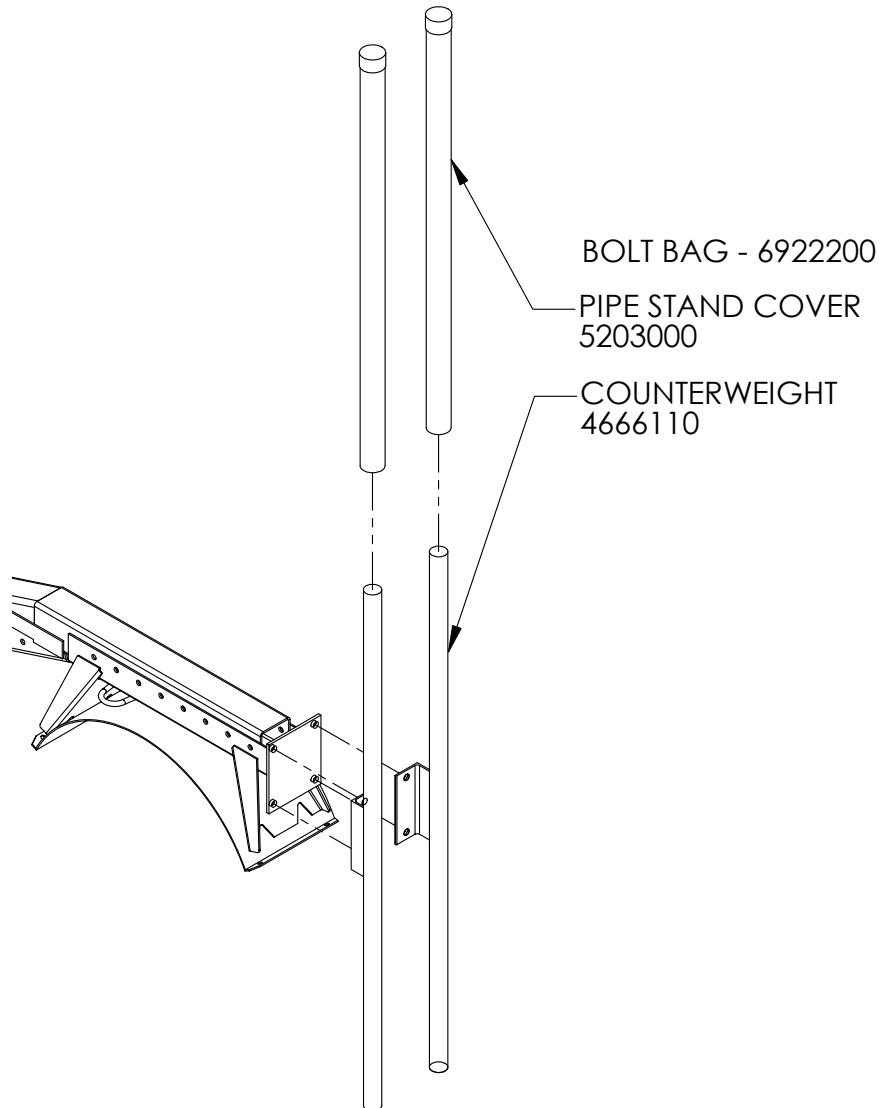

Installation

Selecting Position for Boat & Hoist

Step	Procedure
1.1 Fig. F1	Pull the boat into the boat slip so that the bow can be easily reached from the front of the slip. Allow at least 12 inches of space between the dock and the boat, at the dock level, in the event the boat may need to be later moved in final positioning.
1.2	With the boat in the desired location, place a mark on the dock where the boat's transom is positioned. Note: Do not include extensions to the hull such as swim platforms; the transom mark should reflect the location of the end of the bottom of the hull.
1.3	Remove the boat and pull the hoist into the slip.
1.4	Position the hoist along side the dock and align the rear end of the Hull Support Pads with the transom mark on the dock.
1.5	With the hoist held stationary at this position, place marks on the dock at the location of the Rear Mooring Assembly and the Front Mooring Assembly .

STEP 1.1 - 1.2

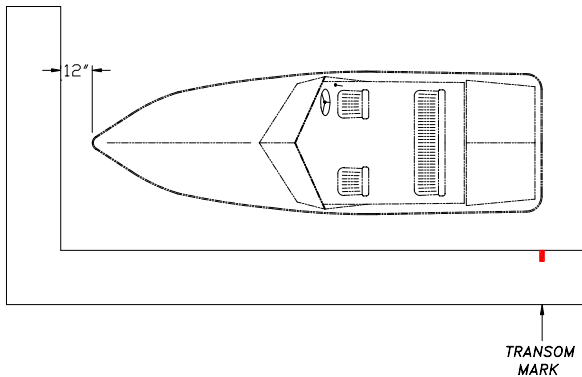

STEP 1.4 - 1.5

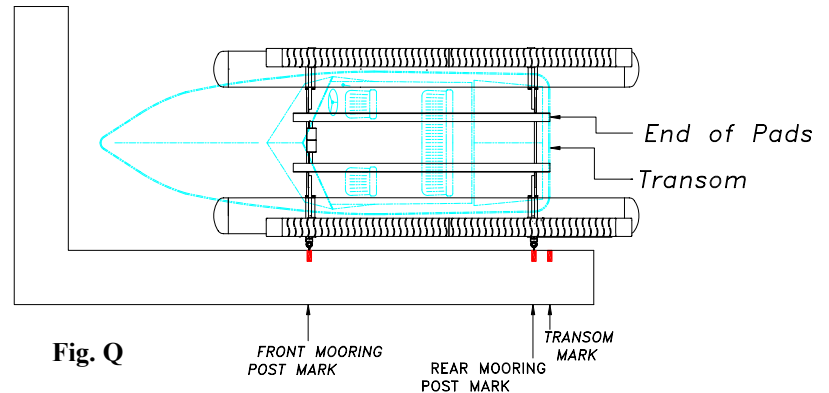
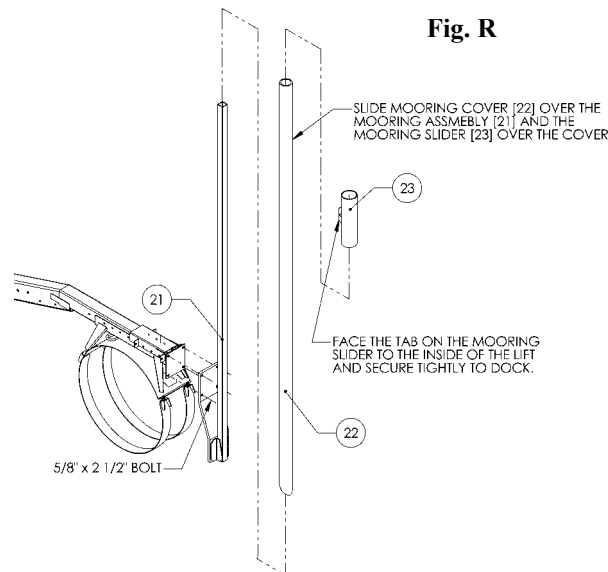

Fig. Q

Mooring the Hoist

Step	Procedure
2.1 Fig. Q	Move the hoist into position and align the rear Mooring Assembly [21] with the mark on the dock.
2.2 Fig. R	Place the Mooring Cover [22] over the Mooring Assembly [21] and the Slider [23] over the Mooring Cover [22]. Securely attach the Slider [23] of each Mooring Assembly to the dock. This may be done with a suitable rope of 3/4" diameter (max.). The tab on the Slider should be positioned away from the dock.

Fig. R



HOSE DIAGRAM

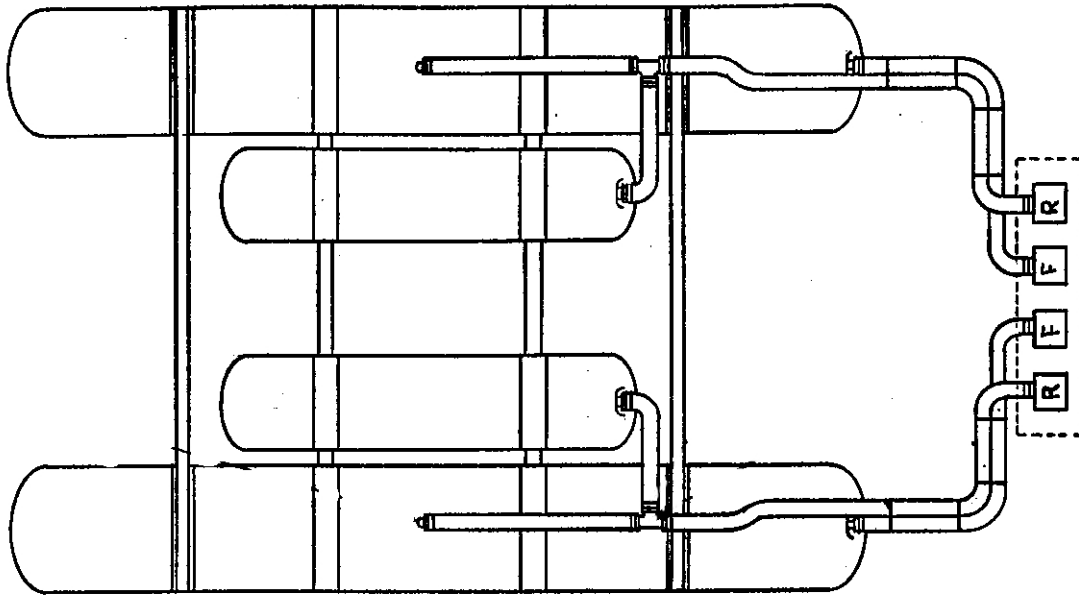

FOUR TANK HOISTS

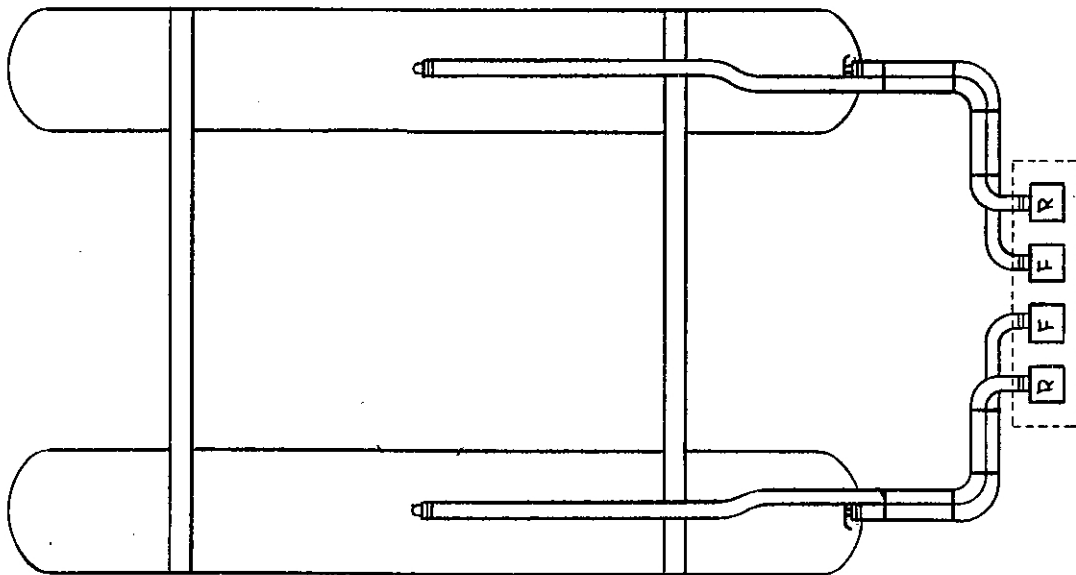

TWO TANK HOISTS

Final Details

Step	Procedure
3.1	TIGHTEN ALL BOLTS.
3.2	REMOVE ALL TANK PLUGS IF USED.
3.3	Attach the Control Unit frame to the dock in the desired location and install the Control Unit Housing onto the frame.
3.4	Connect the power cord to proper power source and test the motor switch to ensure operation.
3.5	Temporarily secure one end of each guide rope to the outboard end of each <i>front</i> Upper Tank Band. Extend each rope to the rear of the hoist and drape it over the Walkway for use later.

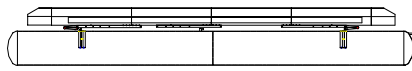

Fully Raised Position

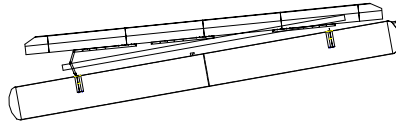
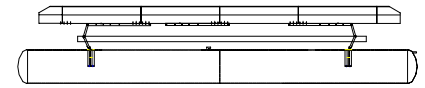

Fig. H1

Stern Lowered Position



Fully Lowered Position

Lowering the Hoist
Fig. H1

Step	Procedure
4.1	Rotate the Control Unit Handles operating the valves leading to the REAR sections of the tanks to the Lift/Launch position. <i>When the air is fully exhausted from the rear section of the tanks, the stern section of the hoist is suspended from the Floating Walkways.</i>
4.2	With the hoist in the Stern Lowered Position (Fig. H1) Rotate the Control Unit Handles operating the valves leading to the FRONT sections of the tanks to the Lift/Launch position. <i>With the air fully exhausted from both the front and rear sections of the tanks, the entire hoist is suspended from the Floating Walkways.</i>

Positioning the Boat

Step	Procedure
5.1	Pull the boat over the hoist and align the boat's transom with the transom mark on the dock. <i>This should properly position the transom just above the end of the Hull Support Pads.</i>
5.2	Hold the boat in position at the transom mark and center it side to side over the hoist. Temporarily tie the loose ends of the Guide Ropes to the REAR cleats of the boat to hold the boat in position for the initial lifting steps.
5.3	Continue to hold the front of the boat centered over the hoist, pushing the boat to stern gently until the Guide Ropes are taut. <i>The Guide Ropes center the boat's stern over the hoist and keep the transom aligned with the rear of the Hull Pads.</i>

Lifting the Boat

Step	Procedure
6.1	Continue holding the boat in position as described in the above step- Rotate the Control Unit Handles operating the valves leading to the FRONT sections of the tanks to the Lift/Launch position and turn the Power Switch to the ON position. <i>Note: It may be necessary to reset the GFCI switch to activate the switch.</i>
6.2	When the hoist contacts the boat hull and the boat is no longer floating freely, you may discontinue pushing back on the boat. As the FRONT of the hoist and boat rise, observe the centering position of the boat on the Hull Support Pads - if not centered correctly, lower the hoist and realign the boat or pads as necessary.
6.3	Continue raising the FRONT of the hoist until air bubbles from under the FRONT of the tanks, then... Rotate the Control Unit Handles operating the valves leading to the REAR sections of the tanks to the Lift / Launch position, and... rotate the Handles leading to the FRONT sections of the tanks to the Dry-Dock position.
6.4	As the REAR of the hoist and boat rise, observe the centering position of the boat on the Hull Support Pads - if not centered correctly, lower the hoist and realign the boat or pads as necessary.
6.5	Continue raising the REAR of the hoist until air bubbles from under the REAR sections of the tanks, then again... rotate the Control Handles operating the valves leading to the FRONT sections of the tanks to the Lift / Launch position to continue filling the FRONT sections of the tanks.
6.6	When air bubbles from all sections of all tanks, turn the Power Switch to OFF and rotate ALL Control Handles to the Dry-Dock position. The hoist should now be fully lifted.

Parts List

9/12/15/17 B-MODEL PARTS

BL-09-2AF-2T-STD	BL-09-2AF-2T-WD	BL-12-2AF-2T-STD	BL-12-2AF-2T-WD	BL-12-2AF-2T-XWD	BL-12-3AF-2T-STD	BL-12-3AF-2T-WD	BL-12-3AF-2T-XWD	BL-15-3AF-2T-WD	BL-15-3AF-2T-XWD	BL-15-3AF-4T-WD	BL-15-3AF-4T-XWD	BL-17-3AF-4T-WD	BL-17-3AF-4T-XWD
------------------	-----------------	------------------	-----------------	------------------	------------------	-----------------	------------------	-----------------	------------------	-----------------	------------------	-----------------	------------------

TANKS

1A	5014800	TANK ASSY - 32"X23'B	2	2									
1B	5014201	TANK ASSY - 32"X32'B			2	2	2	2	2	2	2	2	2
1C	5012600	TANK ASSY - 32"X38'B							2	2			
2A	5010310	TANK ASSY - 24"X23'B										2	2
2B	5010200	TANK ASSY - 24"X16'A								2	2		

HULL PAD

3A	4260055	16' HULL PADS	2	2									
3B	4260060	20' HULL PADS			2	2	2						
3C	4270060	9' HD HULL PADS					2	2	2	2	2	2	2

V BRACKET

4A	4260035	V BRACKET - TUBE SUPT	1	1	1	1							
4B	4667200	V BRACKET - 20/30B					1	1	1	1	1	1	1

HULL SUPPORT

5	4260045	TUBE - UPPER 2" TUBE	6	6	6	6	6	6	6	6	6	6	6
6	4270160	PAD MOUNT - RECIEVER	4	4	4	4	4	4	4	4	4	4	4
7	4660160	PAD SUPPORT - LOWER ASSY	6	6	6	6	6	6	6	2	2	2	2
8A	4660150	PAD SUPPORT - UPPER ASSY (STD,WD)	6	6	6	6	6	6	2	2	2	2	
8B	4660130	PAD SUPPORT - UPPER ASSY (XWD)				6			6	2	2	2	2
8C	4270071	WELDMENT - PAD MOUNT							4	4	4	4	4
8D	4270072	WELDMENT - PAD MOUNT - OPP							4	4	4	4	4
9	4270073	WELDMENT - BRACE							4	4	4	4	4

TANK BANDS

10A	4660700	TANK BAND - BIG B LOWER	8	8	8	8	8	12	12	12	12	12	12
11A	4666700	TANK BAND - BIG B UPPER	4	4	4	4	4	6	6	6	6	6	6
10B	3056200	TANK BAND - 24" LOWER										4	4
11B	4050100	TANK BAND - 24" UPPER										4	4

FRAME COMPONENTS

12A	4665600	ADJUSTABLE FRAME CENTER STD	2	2		3							
12B	4665900	ADJUSTABLE FRAME CENTER WD		2	2		3		3		3		3
12C	4668600	ADJUSTABLE FRAME CENTER XWD				2		3		3		3	3

WALKWAY COMPONENTS

13	2810000	WALKWAY 10' MODULE	4	4	4	4	4	4	4	4	4	4	4
14	2815000	WALKWAY 5' MODULE	2	2	4	4	4	4	4	4	4	4	4
15	4812095	HINGE BASE - UNIV BIG B	4	4	4	4	4	4	4	4	4	4	4
16	4812060	HINGE ASSY WALKWAY	4	4	4	4	4	4	4	4	4	4	4
17	4812025	HINGE GRIP ASSY	8	8	8	8	8	8	8	8	8	8	8
18	4812030	HINGE GRIP BRACE	4	4	4	4	4	4	4	4	4	4	4
19	4812070	HINGE PIN 10 1/2"	8	8	8	8	8	8	8	8	8	8	8
20	4812085	WALKWAY SPACER - 3FRAME					2	2	2	2	2	2	2

MOORING COMPONENTS

21	4666100	EURO MOORING ASSY	2	2	2	2	2	2	2	2	2	2	2
22	4666150	EURO MOORING COVER - BIG B	2	2	2	2	2	2	2	2	2	2	2
23	4669165	EURO MOORING SLIDER	2	2	2	2	2	2	2	2	2	2	2

CONTROL UNIT

24	3550028	CONTROL UNIT - 4V-2M (PLASTIC MAN.)	1	1	1	1	1	1	1	1	1	1	1
----	---------	-------------------------------------	---	---	---	---	---	---	---	---	---	---	---

HOSE

25	3072502	HOSE 75'	1	1	1	1	1	1	1	1	1	1	1
	3072504	HOSE 10'									1	1	1
	3072507	HOSE 40'	1	1	1	1	1	1	1	1	1	1	1

PARTS BAGS

	6921652	PARTS BAG - 2FRAME LP	1	1									
	6921751	PARTS BAG - 12B			1	1	1	1	1				
	6921752	PARTS BAG - 15B 2T							1	1			
	6921753	PARTS BAG - 15B 4T									1	1	
	6921754	PARTS BAG - 17B											1
	6921850	PARTS BAG - BIG B - XWD											1
	6937500	PARTS BAG - CABLE ASSY 9/12/15/20	1	1	1	1	1	1	1	1	1	1	1
	6937100	PARTS BAG - WALKWAY 45/75/9											
	6937200	PARTS BAG - WALKWAY 12/15/17	1	1									
	6937225	PARTS BAG - WALKWAY 12B 2 FRAME			1	1	1						

Final Adjustments

Balance and Load

Step	Procedure
1.1	Carefully check the boat's position on the hoist and Hull Support Pads. The boat should be centered side to side, with the hull Support Pads contacting the hull between the chines and to the transom area. Note 1: It is common for some unavoidable crossing of the chines at the bow of the boat, which is acceptable. Note 2: The ends of the Hull Support Pads should extend to the transoms of outboard boats; for stern-drive boats, the ends of the Hull Support Pads should not extend forward of the engine compartment. Reposition the boat or pads if necessary.
1.2	Carefully check the hoist's position in the water. The tanks should be level fore to aft with an acceptable 4-inch drop to stern. Correct the fore to aft position of the boat on the hoist to rectify any unbalance.
1.3	At least 1/3 of each tank should be above the water surface for correct lifting and hoist stability. If less than 1/3 of the tank is above the water, the boat is too heavy for the hoist and a larger hoist should be installed.

Guide Ropes

Step	Procedure
2.1	With the boat correctly positioned on the hoist, untie both the FRONT and REAR ends of each Guide rope. Tie a small loop (about 6 inches in diameter) in one end of each Guide Rope and place the loops over the REAR cleats of the boat.
2.2	Pull the Guide Ropes tight and tie the loose ends to the outboard ends of each FRONT Upper Tank Band. (Right rope to right tank band, left rope to left tank band.)
2.3	Attach the Warning Decals (2003400) to the Guide Ropes.

Final Inspection

Step	Procedure
3.1	Operate the hoist again - launch then lift - checking for proper positioning of the boat and Pads and for proper operation of the lift and Walkways.

Wrapping Up

<ul style="list-style-type: none"> ◆ Secure a bow line to the boat and to the boat dock. ◆ Confirm that the Operating Instructions are in the Control Unit. ◆ Unplug the power cord and stow it in a secure position. ◆ Complete the Warranty information and apply the adhesive Serial Number Tag to the Top Plate of the Control Unit. ◆ Close and secure the Control Unit Lid. ◆ Whenever possible, instruct the boat owner in the proper operating procedures of the hoist.

CAUTION:
 HIGH WINDS
 AND
 ROUGH WATER
 CONDITIONS

The HydroHoist Mooring Apparatus is not designed for severe wind or water conditions. Should the potential for severe conditions exist, it is recommended that mooring lines be secured from dock structure to bow and stern of craft to prevent damage to the HydroHoist Mooring Apparatus.

Trouble Shooting

CONDITION:	Hoist will not completely lift boat from water or stern remains low.
CAUSE:	A. Boat loaded too far to rear. B. Water or equipment in boat creating additional weight. C. Boat weight exceeds lifting capacity of hoist.
CORRECTION:	A. Reposition boat forward to balance weight over hoist and adjust the Guide Ropes to maintain proper positioning. B. Remove water or equipment. C. Install correct size hoist to accommodate the boat's true weight.
CONDITION:	Hoist tips side to side when lifting or launching.
CAUSE:	A. Restricted air flow to one quadrant of the lifting tanks. B. Hoses not of equal length. C. Bulkhead inside of tank is broken or leaking D. Host is not square, frame is twisted.
CORRECTION:	A. Remove kinks or water-lock from hoses. B. Correct hose length. C. Replace tank. D. Loosen Tank Bands, level hoist, and properly tighten Tank Bands.
CONDITION:	Walkways unstable when walked upon.
CAUSE:	A. Brace system not functioning properly.
CORRECTION:	A. Repair or replace.
CONDITION:	Hoist leans down on one corner.
CAUSE:	A. Leak in valve, tank, or hose for that quadrant.
CORRECTION:	A. Locate leak and repair.
CONDITION:	Hoist leans down on one side (not just one corner).
CAUSE:	A. Leak in fore and aft quadrant - tank to valve or bulkhead leaking.
CORRECTION:	A. Locate leak and repair. Replace tank if bulkhead damaged.

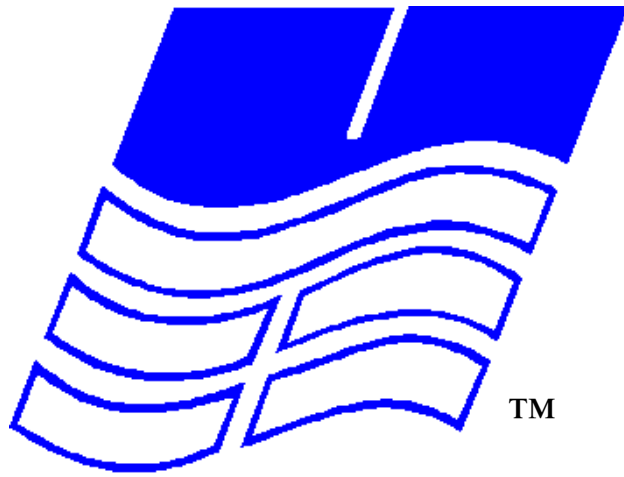

TM