

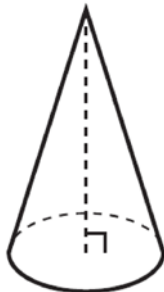



0116geo

- 1 William is drawing pictures of cross sections of the right circular cone below.



Which drawing can *not* be a cross section of a cone?

- 1) 
- 2) 
- 3) 
- 4) 

- 2 An equation of a line perpendicular to the line represented by the equation  $y = -\frac{1}{2}x - 5$  and passing through  $(6, -4)$  is
- 1)  $y = -\frac{1}{2}x + 4$
  - 2)  $y = -\frac{1}{2}x - 1$
  - 3)  $y = 2x + 14$
  - 4)  $y = 2x - 16$

- 3 In parallelogram  $QRST$  shown below, diagonal  $\overline{TR}$  is drawn,  $U$  and  $V$  are points on  $\overline{TS}$  and  $\overline{QR}$ , respectively, and  $\overline{UV}$  intersects  $\overline{TR}$  at  $W$ .

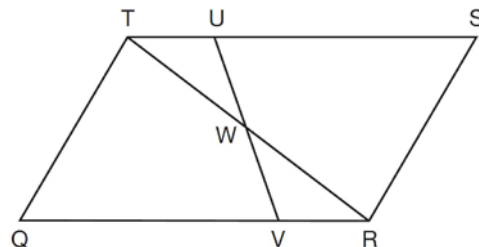

If  $m\angle S = 60^\circ$ ,  $m\angle SRT = 83^\circ$ , and  $m\angle TWU = 35^\circ$ , what is  $m\angle WVQ$ ?

- 1)  $37^\circ$
  - 2)  $60^\circ$
  - 3)  $72^\circ$
  - 4)  $83^\circ$
- 4 A fish tank in the shape of a rectangular prism has dimensions of 14 inches, 16 inches, and 10 inches. The tank contains 1680 cubic inches of water. What percent of the fish tank is empty?
- 1) 10
  - 2) 25
  - 3) 50
  - 4) 75
- 5 Which transformation would result in the perimeter of a triangle being different from the perimeter of its image?
- 1)  $(x, y) \rightarrow (y, x)$
  - 2)  $(x, y) \rightarrow (x, -y)$
  - 3)  $(x, y) \rightarrow (4x, 4y)$
  - 4)  $(x, y) \rightarrow (x + 2, y - 5)$

- 6 In the diagram below,  $\overleftrightarrow{FE}$  bisects  $\overline{AC}$  at  $B$ , and  $\overleftrightarrow{GE}$  bisects  $\overline{BD}$  at  $C$ .

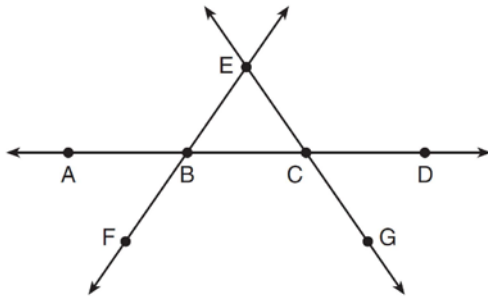

Which statement is always true?

- 1)  $\overline{AB} \cong \overline{DC}$
  - 2)  $\overline{FB} \cong \overline{EB}$
  - 3)  $\overleftrightarrow{BD}$  bisects  $\overline{GE}$  at  $C$ .
  - 4)  $\overleftrightarrow{AC}$  bisects  $\overline{FE}$  at  $B$ .
- 7 As shown in the diagram below, a regular pyramid has a square base whose side measures 6 inches.

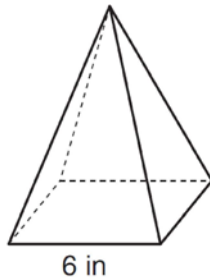

If the altitude of the pyramid measures 12 inches, its volume, in cubic inches, is

- 1) 72
- 2) 144
- 3) 288
- 4) 432

- 8 Triangle  $ABC$  and triangle  $DEF$  are graphed on the set of axes below.

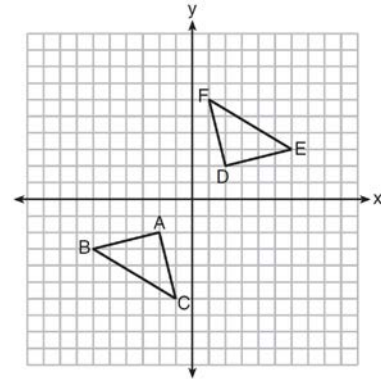

Which sequence of transformations maps triangle  $ABC$  onto triangle  $DEF$ ?

- 1) a reflection over the  $x$ -axis followed by a reflection over the  $y$ -axis
  - 2) a  $180^\circ$  rotation about the origin followed by a reflection over the line  $y = x$
  - 3) a  $90^\circ$  clockwise rotation about the origin followed by a reflection over the  $y$ -axis
  - 4) a translation 8 units to the right and 1 unit up followed by a  $90^\circ$  counterclockwise rotation about the origin
- 9 In  $\triangle ABC$ , the complement of  $\angle B$  is  $\angle A$ . Which statement is always true?
- 1)  $\tan \angle A = \tan \angle B$
  - 2)  $\sin \angle A = \sin \angle B$
  - 3)  $\cos \angle A = \tan \angle B$
  - 4)  $\sin \angle A = \cos \angle B$
- 10 A line that passes through the points whose coordinates are  $(1, 1)$  and  $(5, 7)$  is dilated by a scale factor of 3 and centered at the origin. The image of the line
- 1) is perpendicular to the original line
  - 2) is parallel to the original line
  - 3) passes through the origin
  - 4) is the original line

- 11 Quadrilateral  $ABCD$  is graphed on the set of axes below.

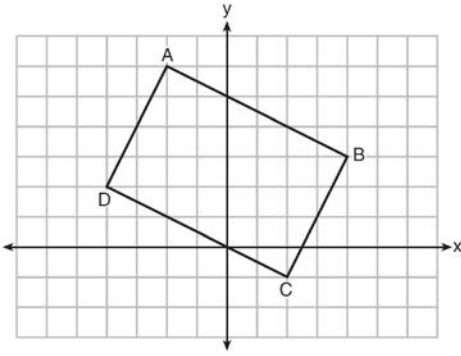

When  $ABCD$  is rotated  $90^\circ$  in a counterclockwise direction about the origin, its image is quadrilateral  $A'B'C'D'$ . Is distance preserved under this rotation, and which coordinates are correct for the given vertex?

- 1) no and  $C'(1,2)$
  - 2) no and  $D'(2,4)$
  - 3) yes and  $A'(6,2)$
  - 4) yes and  $B'(-3,4)$
- 12 In the diagram below of circle  $O$ , the area of the shaded sector  $LOM$  is  $2\pi \text{ cm}^2$ .

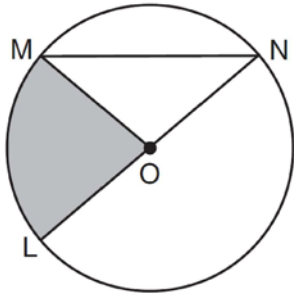

- If the length of  $\overline{NL}$  is 6 cm, what is  $m\angle N$ ?
- 1)  $10^\circ$
  - 2)  $20^\circ$
  - 3)  $40^\circ$
  - 4)  $80^\circ$

- 13 In the diagram below,  $\triangle ABC \sim \triangle DEF$ .

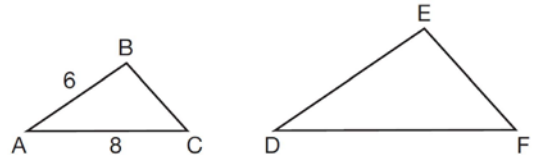

If  $AB = 6$  and  $AC = 8$ , which statement will justify similarity by SAS?

- 1)  $DE = 9$ ,  $DF = 12$ , and  $\angle A \cong \angle D$
  - 2)  $DE = 8$ ,  $DF = 10$ , and  $\angle A \cong \angle D$
  - 3)  $DE = 36$ ,  $DF = 64$ , and  $\angle C \cong \angle F$
  - 4)  $DE = 15$ ,  $DF = 20$ , and  $\angle C \cong \angle F$
- 14 The diameter of a basketball is approximately 9.5 inches and the diameter of a tennis ball is approximately 2.5 inches. The volume of the basketball is about how many times greater than the volume of the tennis ball?
- 1) 3591
  - 2) 65
  - 3) 55
  - 4) 4
- 15 The endpoints of one side of a regular pentagon are  $(-1,4)$  and  $(2,3)$ . What is the perimeter of the pentagon?
- 1)  $\sqrt{10}$
  - 2)  $5\sqrt{10}$
  - 3)  $5\sqrt{2}$
  - 4)  $25\sqrt{2}$

- 16 In the diagram of right triangle  $ABC$  shown below,  $AB = 14$  and  $AC = 9$ .

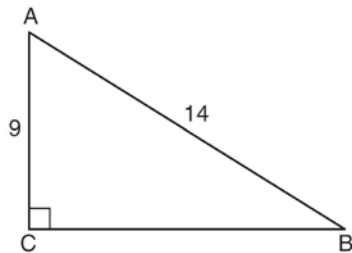

What is the measure of  $\angle A$ , to the nearest degree?

- 1) 33
  - 2) 40
  - 3) 50
  - 4) 57
- 17 What are the coordinates of the center and length of the radius of the circle whose equation is  $x^2 + 6x + y^2 - 4y = 23$ ?
- 1)  $(3, -2)$  and 36
  - 2)  $(3, -2)$  and 6
  - 3)  $(-3, 2)$  and 36
  - 4)  $(-3, 2)$  and 6
- 18 The coordinates of the vertices of  $\triangle RST$  are  $R(-2, -3)$ ,  $S(8, 2)$ , and  $T(4, 5)$ . Which type of triangle is  $\triangle RST$ ?
- 1) right
  - 2) acute
  - 3) obtuse
  - 4) equiangular
- 19 Molly wishes to make a lawn ornament in the form of a solid sphere. The clay being used to make the sphere weighs .075 pound per cubic inch. If the sphere's radius is 4 inches, what is the weight of the sphere, to the nearest pound?
- 1) 34
  - 2) 20
  - 3) 15
  - 4) 4

- 20 The ratio of similarity of  $\triangle BOY$  to  $\triangle GRL$  is 1:2. If  $BO = x + 3$  and  $GR = 3x - 1$ , then the length of  $\overline{GR}$  is
- 1) 5
  - 2) 7
  - 3) 10
  - 4) 20

- 21 In the diagram below,  $\overline{DC}$ ,  $\overline{AC}$ ,  $\overline{DOB}$ ,  $\overline{CB}$ , and  $\overline{AB}$  are chords of circle  $O$ ,  $\overleftrightarrow{FDE}$  is tangent at point  $D$ , and radius  $\overline{AO}$  is drawn. Sam decides to apply this theorem to the diagram: "An angle inscribed in a semi-circle is a right angle."

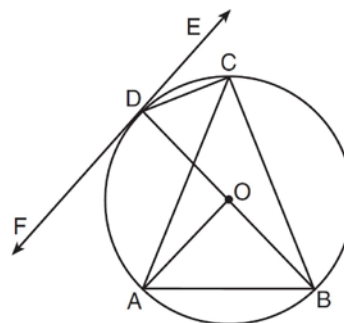

Which angle is Sam referring to?

- 1)  $\angle AOB$
  - 2)  $\angle BAC$
  - 3)  $\angle DCB$
  - 4)  $\angle FDB$
- 22 In the diagram below,  $\overline{CD}$  is the altitude drawn to the hypotenuse  $\overline{AB}$  of right triangle  $ABC$ .

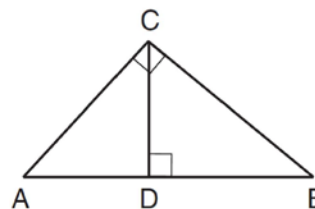

Which lengths would *not* produce an altitude that measures  $6\sqrt{2}$ ?

- 1)  $AD = 2$  and  $DB = 36$
- 2)  $AD = 3$  and  $AB = 24$
- 3)  $AD = 6$  and  $DB = 12$
- 4)  $AD = 8$  and  $AB = 17$

- 23 A designer needs to create perfectly circular necklaces. The necklaces each need to have a radius of 10 cm. What is the largest number of necklaces that can be made from 1000 cm of wire?
- 1) 15
  - 2) 16
  - 3) 31
  - 4) 32

- 24 In  $\triangle SCU$  shown below, points  $T$  and  $O$  are on  $\overline{SU}$  and  $\overline{CU}$ , respectively. Segment  $OT$  is drawn so that  $\angle C \cong \angle OTU$ .

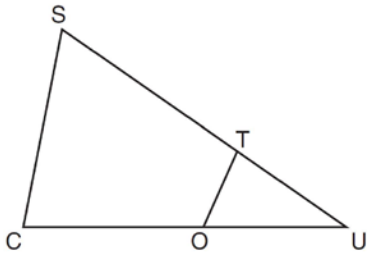

If  $TU = 4$ ,  $OU = 5$ , and  $OC = 7$ , what is the length of  $ST$ ?

- 1) 5.6
  - 2) 8.75
  - 3) 11
  - 4) 15
- 25 Triangle  $ABC$  is graphed on the set of axes below. Graph and label  $\triangle A'B'C'$ , the image of  $\triangle ABC$  after a reflection over the line  $x = 1$ .

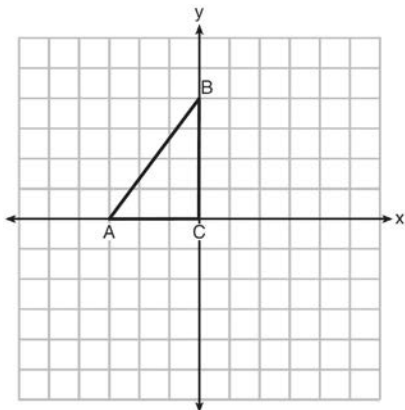

- 26 In the diagram below of circle  $O$  with diameter  $\overline{BC}$  and radius  $\overline{OA}$ , chord  $\overline{DC}$  is parallel to chord  $\overline{BA}$ .

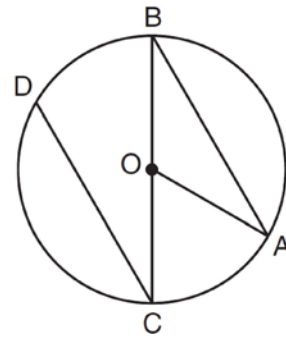

If  $m\angle BCD = 30^\circ$ , determine and state  $m\angle AOB$ .

- 27 Directed line segment  $\overline{PT}$  has endpoints whose coordinates are  $P(-2, 1)$  and  $T(4, 7)$ . Determine the coordinates of point  $J$  that divides the segment in the ratio 2 to 1. [The use of the set of axes below is optional.]

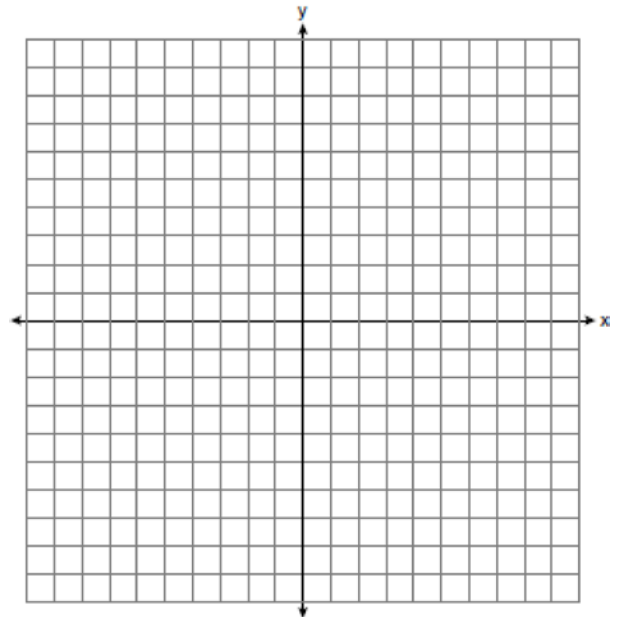

- 28 As graphed on the set of axes below,  $\triangle A'B'C'$  is the image of  $\triangle ABC$  after a sequence of transformations.

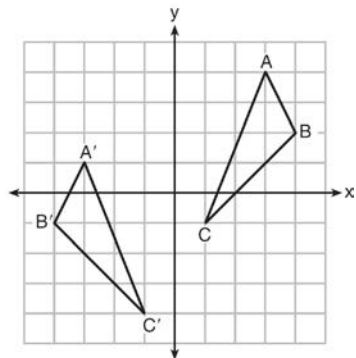

Is  $\triangle A'B'C'$  congruent to  $\triangle ABC$ ? Use the properties of rigid motion to explain your answer.

- 29 A carpenter leans an extension ladder against a house to reach the bottom of a window 30 feet above the ground. As shown in the diagram below, the ladder makes a  $70^\circ$  angle with the ground. To the *nearest foot*, determine and state the length of the ladder.

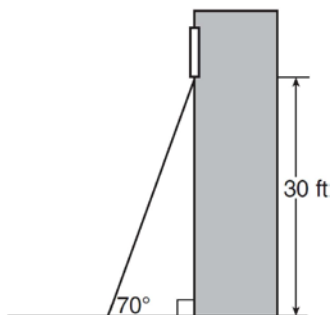

- 30 During an experiment, the same type of bacteria is grown in two petri dishes. Petri dish *A* has a diameter of 51 mm and has approximately 40,000 bacteria after 1 hour. Petri dish *B* has a diameter of 75 mm and has approximately 72,000 bacteria after 1 hour.

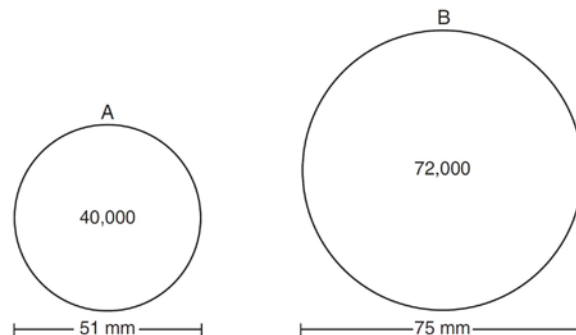

Determine and state which petri dish has the greater population density of bacteria at the end of the first hour.

- 31 Line  $\ell$  is mapped onto line  $m$  by a dilation centered at the origin with a scale factor of 2. The equation of line  $\ell$  is  $3x - y = 4$ . Determine and state an equation for line  $m$ .
- 32 The aspect ratio (the ratio of screen width to height) of a rectangular flat-screen television is 16:9. The length of the diagonal of the screen is the television's screen size. Determine and state, to the *nearest inch*, the screen size (diagonal) of this flat-screen television with a screen height of 20.6 inches.

- 33 Given the theorem, “The sum of the measures of the interior angles of a triangle is  $180^\circ$ ,” complete the proof for this theorem.

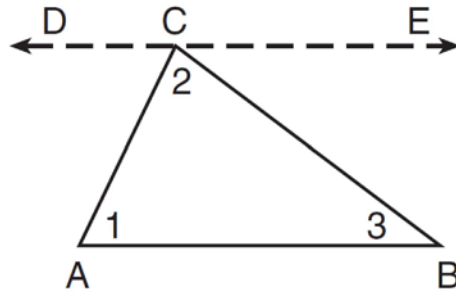

Given:  $\triangle ABC$

Prove:  $m\angle 1 + m\angle 2 + m\angle 3 = 180^\circ$

Fill in the missing reasons below.

Statements	Reasons
(1) $\triangle ABC$	(1) Given
(2) Through point C, draw $\overleftrightarrow{DCE}$ parallel to $\overline{AB}$ .	(2) _____ _____ _____
(3) $m\angle 1 = m\angle ACD$ , $m\angle 3 = m\angle BCE$	(3) _____ _____ _____
(4) $m\angle ACD + m\angle 2 + m\angle BCE = 180^\circ$	(4) _____ _____ _____
(5) $m\angle 1 + m\angle 2 + m\angle 3 = 180^\circ$	(5) _____ _____ _____

- 34 Triangle  $XYZ$  is shown below. Using a compass and straightedge, on the line below, construct and label  $\triangle ABC$ , such that  $\triangle ABC \cong \triangle XYZ$ . [Leave all construction marks.] Based on your construction, state the theorem that justifies why  $\triangle ABC$  is congruent to  $\triangle XYZ$ .

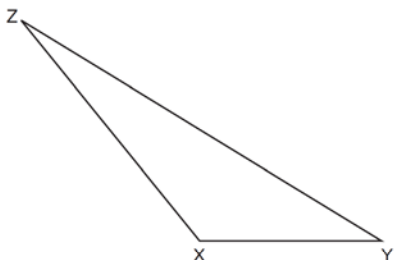

- 35 Given: Parallelogram  $ANDR$  with  $\overline{AW}$  and  $\overline{DE}$  bisecting  $\overline{ND}$  and  $\overline{RA}$  at points  $W$  and  $E$ , respectively

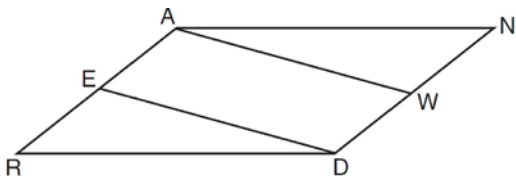

Prove that  $\triangle ANW \cong \triangle DRE$ . Prove that quadrilateral  $AWDE$  is a parallelogram.

- 36 Cathy wants to determine the height of the flagpole shown in the diagram below. She uses a survey instrument to measure the angle of elevation to the top of the flagpole, and determines it to be  $34.9^\circ$ . She walks 8 meters closer and determines the new measure of the angle of elevation to be  $52.8^\circ$ . At each measurement, the survey instrument is 1.7 meters above the ground.

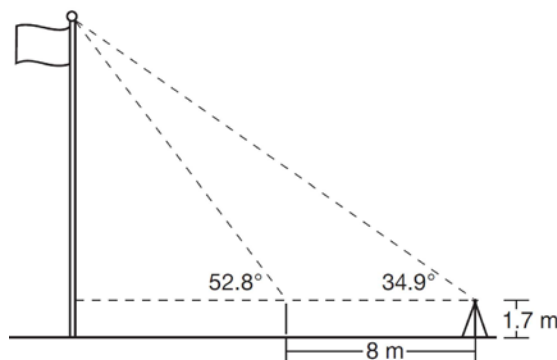

Determine and state, to the *nearest tenth of a meter*, the height of the flagpole.