

Piston Accumulators

Threaded Piston Accumulators ■ ACP Crimped Piston ■ Gas Bottles
■ Metric Accumulators & Bottles

IN THIS SECTION

Series 2000 & 3000	29
ACP Piston Accumulators	37
Series 4000 & 5000	43

Features:

- Heavy Duty Service with Operating Pressures to 5000 PSI
- 1.5" thru 12" Bores with Over Fifty Standard Capacities
- "Fatigue Tested" Designs, 2" thru 7" Bores
- V-O-ring Piston Seals Std
- Serviceable Threaded End Construction
- Certifications Available: ASME, DNV, ABS, AS1210, SELO, CRN, GOST, CE
- Five Standard Seal Options to Handle a Variety of Fluids and Temperatures
- Temperature Ranges -45° to 320°F



Piston accumulators provide a means of regulating the performance of a hydraulic system. They are suitable for storing energy under pressure, absorbing hydraulic shocks, and dampening pump pulsation and flow fluctuations. The simple, compact, cylindrical design of piston accumulators ensures dependable performance, maximum efficiency, and long service life.

Why Use Piston Accumulators?

- Improves System Efficiency
- Supplements Pump Flow
- Supplies Power in Emergency
- Compensates for Leakage
- Absorbs Hydraulic Shocks
- Wide Range of Sizes
- Lower Gas Permeation Rate
- Extremely High-flow Rates
- High/Low Temperature Tolerance
- High Compression Ratios
- Can Be Used With Remote Gas Bottles
- Can Be Mounted in Any Position
- Failure Mode Is Gradual, Predictable
- Sensors Can Be Fitted for Performance Monitoring
- Less Maintenance

Parker Piston Accumulators... Your #1 Choice!

Parker is the leading manufacturer of piston accumulators in North America. Parker's broad offering includes:

- Piston Accumulators for 2000, 3000, 4000 & 5000 PSI
- Gas Bottles for 3000, 4000 & 5000 PSI
- Metric Piston Accumulators for 207, 276 and 345 Bar
- Metric Gas Bottles for 207, 276 and 345 Bar
- A Wide Array of Options and Accessories

Best in Class Capabilities

- Accumulators up to 25" ID and 250 gallons and larger
- Pressure ratings in excess of 20,000 PSI
- Over 40 types of seal options provide compatibility with any fluid and application
- Wide variety of stainless steel and alternative material options
- Extreme temperatures, certified product to -50°F
- Integrated solutions including imbedded valving and controls in accumulator
- Struts and suspension products designed for rugged mobile applications
- Many surface coatings, including epoxies, CARC paints, electroless nickel plating
- Accumulators custom designed for the most demanding markets and global locations
- Unique lockout and tag-out integrated functions
- DOT shipping exemptions for pre-charged vessels

Our Wide Range of Piston Accumulators . . .

Our Piston Accumulator Series

Parker offers standard piston accumulators rated for 2000, 3000, 4000 and 5000 PSI. To make it easier for you to order, we have divided the piston accumulator section into Series 2000 & 3000, ACP Accumulators and Series 4000 & 5000 with separate technical and ordering information. Please consult the factory for a wide variety of accumulators with pressure ratings exceeding 5000 PSI.

Series 3000 7" Bore Now Available in Non-ASME

ASME certification is a requirement of strength and material traceability (see page 6). Many markets require ASME certification, but not all. It is the function of the system designer to specify whether ASME is or is not required.

We now offer a 7" bore true non-ASME accumulator which meets ASME Section VIII, Division I design requirements while utilizing industry standard materials. When ASME certification is not required, specifying these accumulators can result in moderate savings.

Series 2000 12" Bore

Parker offers piston accumulators rated for 2000 PSI. When a 12" bore is required with a minimum operating pressure of 2,000 PSI or less, specifying these accumulators can result in moderate savings.

- ① Piston type accumulators are designed with compact, rugged **steel shell and caps**. The steel shell allows heat to dissipate effectively. The bore is micro-finished for extended seal life. The threaded caps allow for easy repair and seal replacement.
- ② The **piston seal** consists of a unique, five-bladed V-O-ring with back-up washers. This design eliminates seal roll-over and ensures total separation of fluid and gas under the most severe operating conditions.

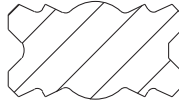

The V-O-ring also holds full pressure throughout long idle periods between cycles, providing dependable, full pressure storage of hydraulic energy. It ensures safe, reliable absorption of pressure peaks. The piston seal design helps to prevent sudden failure of the accumulator.

The V-O-ring seals are available in a wide variety of compounds to cover a broad range of fluids and operating temperature ranges (see Options).

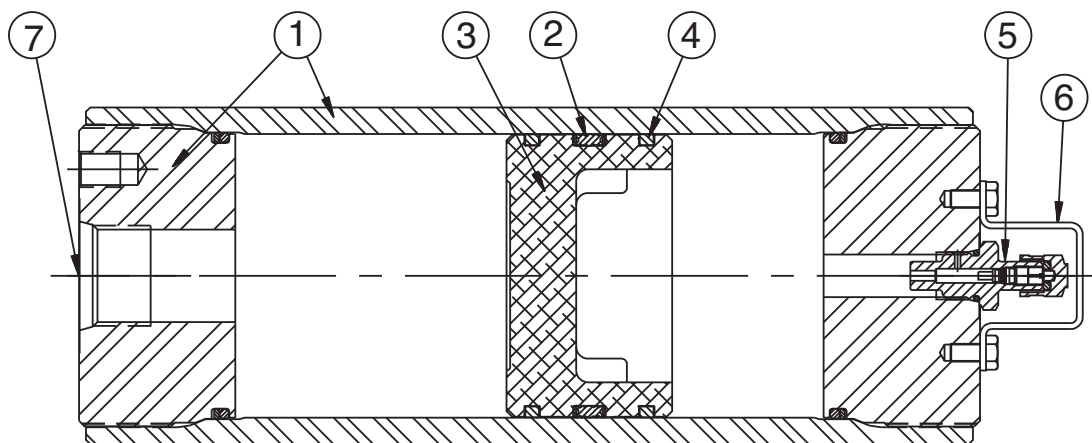

- ③ The **lightweight piston** design allows fast response to reduce shock in rapid cycling applications. The dished profile of the piston provides extra gas capacity and greater useable volume of fluid.
- ④ **PTFE glide rings** eliminate metal-to-metal contact between the tube and piston, reducing wear and extending service life.
- ⑤ All piston accumulators are fitted with a standard designed **gas valve** for ease of gas precharging. Series 3000, 3" thru 6" bores, are fitted with standard cored gas valve cartridges (ISO-4570-8V1). The Series 4000 and Series 5000, 3" thru 6" bores, have as standard a gas valve with a 5000 PSI high-pressure valve cartridge. Offered as an option is a high flow gas valve (L07689000K). For 7" thru 12" bore sizes, the high flow gas valve is standard. The high-flow gas valve is available by special request – please consult factory.
- ⑥ The steel **gas valve protector** reduces the risk of damage to the gas valve from external impact.
- ⑦ A **wide range of port types and sizes** are available. SAE straight thread and SAE flange ports are fitted as standard. NPTF, SAE 4-bolt & special flanges, BSPP, Metric, and ISO 6149-1 ports are available options.

Notes

Series 3000 Piston Accumulators

(and 12" units at 2,000 PSI)

IN THIS SECTION

Overview	29
Specifications & Options	30
Models, Capacities & Dimensions	
Series 3000	32
Series 2000 (12" bore only)	33
Port Options	34
Parts & Accessories	35
Ordering Information	36

Features

- Heavy Duty Service with 3000 PSI Operating Pressure
- 3" thru 12" Bores with More Than 50 Standard Capacities
- V-O-ring Piston Seals
- Serviceable Threaded End Construction
- Five Standard Seal Options to Handle a Variety of Fluids and Temperatures
- ASME/DNV/ABS/AS1210/SELO/CRN/GOST/CE Certifications Available
- Temperature Ranges -45° to 320°F



Materials

- Shell – high strength alloy steel
- Caps – steel
- Pistons – aluminum (3" thru 7"), ductile iron (9" & 12")
- Gas Valve Cartridge – steel
- Gas Valve Protector – steel
- Piston Glide Rings – PTFE
- Piston & End Seals – various polymers
- Piston Seal Backups – PTFE

Actual Bore Sizes & Maximum Flow Rates

Nominal Bore Size (in)	Actual Bore Size		Max. Recommended Flow*	
	(in)	(mm)	GPM	LPM
3	3.00	76.20	220	834
4	4.03	102.4	397	1504
6	5.78	146.9	818	3096
7	7.00	177.8	1199	4538
9	9.00	228.6	1982	7502
12	11.88	301.6	3450	13061

*Note: Based on 120 in/sec maximum piston speed, port & fitting size will become limiting factors for most applications.

Pressure Ratings

Parker Series 3000 piston accumulators are rated at 3000 PSI and a minimum 4 to 1 design factor. Pressures over 3000 PSI, see Series 4000 and Series 5000 accumulators. For pressures over 5000 PSI consult factory.

Fluids

Parker's piston accumulators are compatible with a wide variety of fluids. Standard accumulators (with nitrile seals) may be used with petroleum-based industrial oils or water-based flame resistant fluids. Optional seals compatible with most industrial fluids are available with temperature ranges from -45°F to 320°F (-43°C to 160°C).

Precharge

Units are shipped with a nominal nitrogen precharge as standard. For specific precharge pressures, specify at the time of order.

Auxiliary Gas Bottles

When space does not permit the installation of the required piston accumulator, a smaller accumulator may be used by connecting it to an auxiliary gas bottle(s) that can be located in a nearby spot where space is available. In some cases, a piston accumulator and gas bottle combination may be more economical, especially large capacity sizes. Piston travel, confined to the accumulator, must be calculated with ample margins to store the required fluid.

Standard Ports

The following ports are supplied as standard on all fluid ends and on the gas end of accumulators ordered for use with gas bottles:

Notes:

- 1) For flange dimensions, see tables below.
- 2) On standard 7" & 9" bore accumulators, both SAE Straight Thread and Flange ports are available as standard. Omit port code for SAE #32 Straight Thread, specify "PL" port code for 2" Code 61 Flange when ordering. Flange ports are recommended at operating pressures above 2000 PSI due to pressure limitations of most #32 SAE Straight Thread fittings.

Bore Size	Standard Ports			
	Standard Models		Metric Models	
	SAE Port	SAE Flange ¹	BSP Port (in)	Metric SAE Flange ¹
3	#12	–	1	–
4	#20	–	1	–
6	#24	–	1-1/2	–
7	#32	2" Code 61	–	2" Code 61
9	#32	2" Code 61	–	2" Code 61
12	–	3" Code 61	–	3" Code 61

¹ See flange dimensions in Port Options.

Gas Valves

Two types of gas valves are available on Series 3000 piston accumulators and gas bottles. Units with 3" thru 6" bores, are offered with a cored gas valve cartridge (ISO-4570-8V1) as standard. All 7" thru 12" bore units are supplied with a heavy-duty, high-pressure, poppet-type gas valve cartridge (L07689000K) as standard.

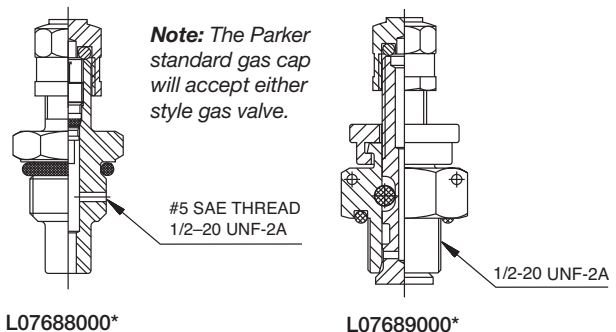

L07688000*

L07689000*

Available Options

If your application requires a piston accumulator, gas bottle, or special option that falls outside of Parker's broad offering, consult your local distributor, Parker representative, or the factory with your specific requirements. Parker has the manufacturing and engineering expertise to design and build piston accumulators to your exacting requirements, from simple modifications of standard units to complete designs. Some example of Parker's past special designs include:

- High Pressures
- Special and Stainless Steel Materials
- Piston Position and Velocity Sensors and Switches
- Water Service
- Non-Standard Capacities
- Extreme Temperatures

Water Service Option (W)

Piston accumulators are available for use with water as the fluid media. Modifications include electroless nickel plating all surfaces and metal parts. Consult factory for details.

Seal Material Options

Seal Code	Polymer	**Recommended Operating Temperature Range	Maximum Temperature with Reduced Life	General Application and Compatibility*
K	Buna-Nitrile	-20°F to 165°F -29°C to 74°C	200°F 93°C	Parker's Standard Compound – Compatible with most mineral oil-based fluids
E	Fluorocarbon Elastomer	-10°F to 250°F -23°C to 121°C	400°F 204°C	Compatible with most mineral oil-based fluids at higher temperatures and some exotic fluids
D	Ethylene Propylene	-40°F to 250°F -40°C to 121°C	300°F 149°C	Compatible with most phosphate ester fluids and some synthetic fluids
H	Hydrogenated Nitrile	-25°F to 320°F -32°C to 160°C	350°F 177°C	Compatible with most oil-based and biodegradable fluids, maintains sealing effectiveness at a wide range of temperatures
Q	Low Temp. Nitrile	-45°F to 160°F -43°C to 71°C	200°F 93°C	Compatible with most mineral oil-based fluids and maintains sealing effectiveness at low temperatures

*Consult local distributor or factory for fluid compatibility information.

**The temperatures listed indicate the operating temperature range of the seals, not the accumulator. For the Minimum Design Metal Temperature (MDMT) of ASME certified accumulators, refer to page 31.

Gas Valve Option (M)

A heavy-duty, high-pressure, poppet-type gas valve is available on 3" through 6" bores as an option (M). Specify when ordering.

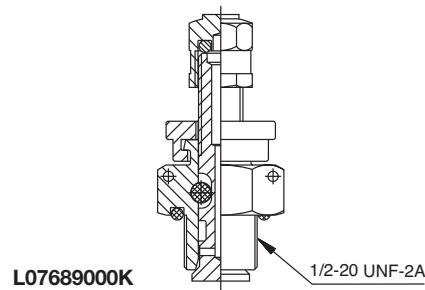

Safety Fuse Options (F)

Safety Fuses are used as a safety device on accumulators and gas bottles to prevent over-pressurization of gas due to external heat or hydraulic pressure (set at 140% of maximum system pressure to avoid rupture disk fatigue and premature failure). The rupture disks are calibrated to rupture at a predetermined pressure. Safety fuses are available on most sizes of piston and bladder accumulators and gas bottles. Safety fuses can be installed on all piston accumulators by using the "Fuse Adapter" as shown to the right. 4" bore units and above can be equipped with a fuse port machined in the gas cap by specifying the "Safety Fuse Option" (F) at the time of order in the model code, see "How to Order." The safety fuse assembly and/or fuse adapter must be ordered separately.

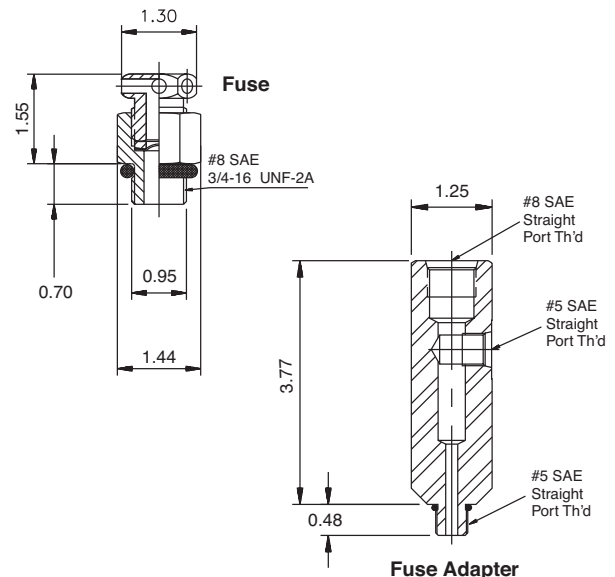

Description	Part Number
Safety Fuse Assembly ¹	086471xxxx
Replacement Rupture Disks	756003xxxx
Fuse Adapter	1468970002

¹Assembly includes housing and rupture disk, xxxx = pressure setting in 100 PSI increments, i.e., for an assembly with a 2000 PSI setting, order P/N 0864712000.

Note: ASME and CRN units available upon request.

3000 PSI (207 Bar Metric) Piston Accumulators for Oil and Water Service

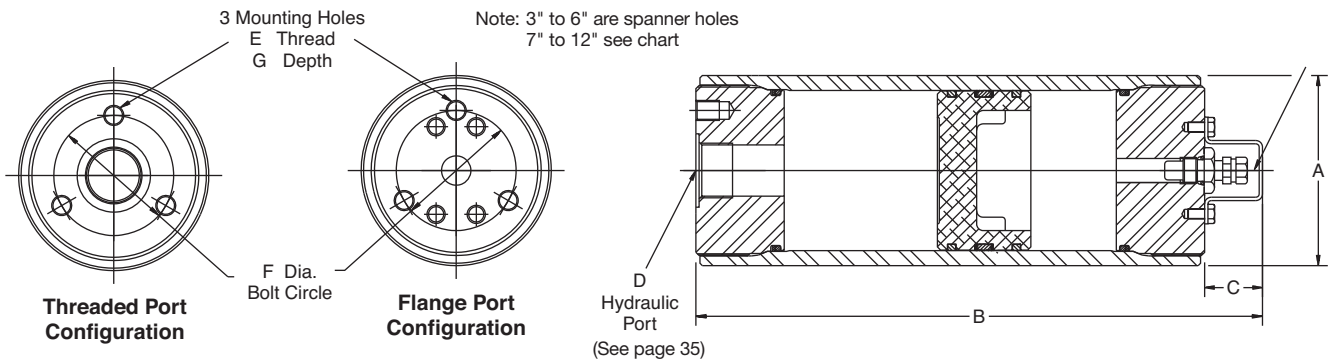

Model No.	Fluid Volume		Gas Volume		A in (mm)	B in (mm)	C in (mm)	E in (mm)	F in (mm)	G in (mm)	Weight lbs (Kg.)
	Oil Service	gal (Liters)	cu in	cu in							
A2N0005D1K (D2K)	- (0.08)	5	6	(0.11)	2.38 (60)	6.76 (172)	1.06 (27)	-	-	-	5 (2.1)
A2N0010D1K (D2K)	- (0.16)	10	11	(0.19)							5 (2.3)
A2N0015D1K (D2K)	- (0.25)	15	16	(0.24)							6 (3.3)
A2N0029D1K (D2K)	1 Pint (0.48)	29	30	(0.50)							7 (2.6)
A2N0058D1K (D2K)	1 Quart (0.95)	58	59	(0.98)	10 (4.7)						
A3N0029D1K (D2K)	1 Pint (0.48)	29	34	(0.56)	3.56 (90)	10.25 (260)	1.13 (29)	.39 (9.9)	2.25 (60)	0.59 (15)	14 (6.5)
A3N0058D1K (D2K)	1 Quart (0.95)	58	63	(1.03)							18 (8.1)
A3N0090D1K (D2K)	1.5 Quart (1.42)	90	95	(1.56)							22 (9.8)
A3N0116D1K (D2K)	1/2 Gal. (1.90)	116	121	(1.98)							25 (11.1)
A3N0183D1K (D2K)	3 Quart (2.84)	183	188	(3.08)							32 (14.6)
A4N0058D1K (D2K)	1 Quart (0.95)	58	68	(1.11)	4.75 (121)	11.63 (295)	1.13 (29)	.45 (11.4)	3.25 (82)	0.68 (18)	29 (13.0)
A4N0116D1K (D2K)	1/2 Gal. (1.90)	116	126	(2.06)							35 (15.9)
A4N0231D1K (D2K)	1 Gal. (3.79)	231	241	(3.95)							48 (21.8)
A4N0347D1K (D2K)	1-1/2 Gal. (5.69)	347	357	(5.85)							61 (27.6)
A4N0578D1K (D2K)	2-1/2 Gal. (9.47)	578	588	(9.64)							87 (39.3)
A6N0231D1K (D2K)	1 Gal. (3.79)	231	266	(4.36)							83 (37.8)
A6N0578D1K (D2K)	2-1/2 Gal. (9.47)	578	613	(10.0)	6.88 (175)	17.38 (441)	1.13 (29)	.45 (11.4)	4.38 (110)	0.84 (22)	124 (56.3)
A6N0924D1K (D2K)	4 Gal. (15.1)	924	959	(15.7)							165 (74.7)
A6N1155D1K (D2K)	5 Gal. (18.9)	1155	1190	(19.5)							192 (87.0)
A6N1733D1K (D2K)	7-1/2 Gal. (28.4)	1733	1768	(29.0)							260 (117.8)
A6N2310D1K (D2K)	10 Gal. (37.9)	2310	2345	(38.4)							327 (148.5)
A7N0578D3KPL (D2K)	2-1/2 Gal (9.47)	578	633	(10.4)							8.13 (206.5)
A7N1155D3KPL (D2K)	5 Gal. (18.9)	1155	1210	(19.8)	226 (103)						
A7N1733D3KPL (D2K)	7-1/2 Gal. (28.4)	1733	1788	(29.3)	283 (129)						
A7N2310D3KPL (D2K)	10 Gal. (37.9)	2310	2365	(38.8)	340 (154)						
A7N3465D3KPL (D2K)	15 Gal. (56.8)	3465	3520	(57.7)	454 (206)						
A7N5775D3KPL (D2K)	25 Gal. (94.6)	5775	5830	(95.5)	682 (309)						
A9K2310D3KPL (D2K)	10 Gal. (37.9)	2310	2400	(39.3)	11.02 (279.9)	48.75 (1238)	1.63 (41)	.75-16 (M20)	7.00 (182)	1.13 (29)	
A9K3465D3KPL (D2K)	15 Gal. (56.8)	3465	3555	(58.3)							758 (344)
A9K4620D3KPL (D2K)	20 Gal. (75.7)	4620	4710	(77.2)							920 (417)
A9K5775D3KPL (D2K)	25 Gal. (94.6)	5775	5865	(96.2)							1083 (491)
A9K6930D3KPL (D2K)	30 Gal. (114)	6930	7020	(115.1)							1246 (565)
A12K5775D1K (D2K)	25 Gal. (94.6)	5775	5975	(97.9)	14.41 (365.9)	67.50 (1715)	1.63 (41)	.875-9 (M20 (6X))	9.00 (230)	1.50 (38)	1336 (606)
A12K6930D1K (D2K)	30 Gal. (114)	6930	7130	(117)							1490 (676)
A12K9240D1K (D2K)	40 Gal. (151)	9240	9440	(155)							1799 (816)
A12K11550D1K (D2K)	50 Gal. (189)	11550	1175	(193)							2108 (956)

The Minimum Design Metal Temperature (MDMT) for ASME certified 7" and 9" piston accumulators presented in this section is 20°F (-7°C).
 The Minimum Design Metal Temperature (MDMT) for ASME certified 12" piston accumulators presented in this section is 32°F (0°C).
 Piston accumulators are available with MDMT below -40°F (-40°C). Consult factory for options.

Notes:

- For Water Service add "W" after construction code, see "How to Order" information.
- Standard accumulators are designated D1K in model number, metric are D2K.
- See "Port Options" for complete listing of standard and optional ports.
- ASME/DNV/ABS/AS1210/SELO/CRN/GOST/ICE certified accumulators and gas bottles are available.
- When accumulators are to be used with gas bottles, order "Accumulators for Use with Gas Bottles."
- 3", 4" & 6" bores standard with cored gas valves. Poppet type (L07689000K) gas valve available as an option.



2000 PSI (139 Bar Metric) Piston Accumulators for Oil and Water Service

We offer a 2000 PSI accumulator in 12" bore size and a variety of capacities for industries where lower pressure ratings can be used.

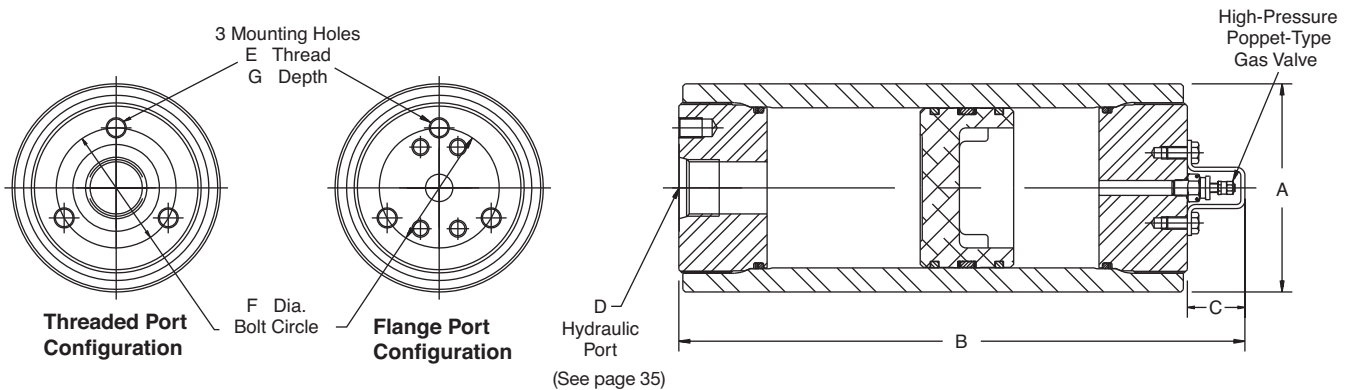

Model No.	Fluid Volume		Gas Volume		A in (mm)	B in (mm)	C in (mm)	E in (mm)	F in (mm)	G in (mm)	Weight lbs (Kg)
	Oil Service	gal (Liters)	cu in	cu in (Liters)							
A12K4620K1K (K2K)	20 (75.71)	4620	4820	(75.71)	14.02	55.75 (1416)					1048 (475)
A12K5775K1K (K2K)	25 (94.64)	5775	5975	(97.91)	±0.09	66.19 (1681)					1193 (541)
A12K6930K1K (K2K)	30 (113.56)	6930	7130	(116.84)	(102.11)	76.62 (1946)	1.62 (41)	7/8-9 (M20) (6X)	9.00 (229)	1.50 (38)	1338 (607)
A12K9240K1K (K2K)	40 (151.42)	9240	9440	(154.69)	±2.29	97.50 (2477)					1628 (738)
A12K11550K1K (K2K)	50 (189.27)	11550	11750	(192.55)		118.37 (3007)					1918 (870)

Notes:

- For Water Service add "W" after construction code, see "How to Order" information.
- Most SAE #32 fittings are rated for 2000 PSI. If 2000 to 3000 PSI service is required, two options are available; order accumulator with optional standard 2" SAE Code 61 4-bolt flange port by specifying "PL" code when ordering or order the accumulator with a SAE #24 port or smaller. See "Port Options" for dimensions and "How to Order".

- See "Port Options" for complete listing of standard and optional ports.
- ASME/DNV/ABS/AS1210/SELO/CRN/GOST/ICE certified accumulators and gas bottles are available.
- When accumulators are to be used with gas bottles, order "Accumulators for Use with Gas Bottles."
- Poppet type (L07689000K) gas valve standard.

Optional Ports

The following ports are available as options on all Series 3000 piston accumulators

SAE Straight Thd.			Code 61 Flange				NPT			BSPP			ISO 6149-1		
Port Size	Port Code	Min. Bore	Port Size	Port Code		Min. Bore	Port Size	Port Code	Min. Bore	Port Size	Port Code	Min. Bore	Port Size	Port Code	Min. Bore
				Inch	Metric										
#5	TA	3"	1/2"	PT	MT	3"	3/8"	UT	3"	3/8"	RA	3"	M14	YA	3"
#6	TB	3"	3/4"	PU	MU	3"	1/2"	UU	3"	1/2"	RB	3"	M18	YB	3"
#8	TC	3"	1"	PV	MV	3"	3/4"	UV	3"	3/4"	RC	3"	M22	YC	3"
#10	TI	3"	1 1/4"	PW	MW	3"	1"	UW	3"	1"	RD	3"	M27	YD	3"
#12	TD	3"	1 1/2"	PJ	MJ	4"	1 1/4"	UX	3"	1 1/4"	RE	3"	M33	YE	3"
#16	TE	3"	2"	PL	ML	6"	1 1/2"	UY	4"	1 1/2"	RF	4"	M42	YF	3"
#20	TF	3"	2 1/2"	PM	MM	6"	2"	UZ	4"	2"	RG	4"	-	-	-
#24	TG	4"	3"	PN	MN	7"	-	-	-	-	-	-	-	-	-

Note:

- 3000 PSI SAE Code 61 (ISO 6162) Flange dimensions are shown below.
- BSPT and Metric ports available, consult factory.

SAE 4-Bolt Flange Port Dimensions

Standard Pressure - 3000 PSI (207 Bar)

Flange Size	SAE Code 61 Flange Dimensions (in)				
	A	B	C	F	G
1 1/2"	1/2 - 13	1.406	2.750	1 1/2	1.062
2"	1/2 - 13	1.688	3.062	2	1.062
2 1/2"	1/2 - 13	2.000	3.500	2 1/2	1.188
3"	5/8 - 11	2.438	4.188	3	1.188

Note: Some flanges using this bolt pattern are not rated for 3000 PSI.

Flange Size	Metric ISO6162 Flange Dimensions (mm)				
	A	B	C	F	G
38	M12	35.7	69.9	38	26.9
51	M12	42.9	77.8	51	26.9
64	M12	50.8	88.9	64	30.1
76	M16	61.9	106.4	76	30.1

Note: Some flanges using this bolt pattern are not rated for 3000 PSI.

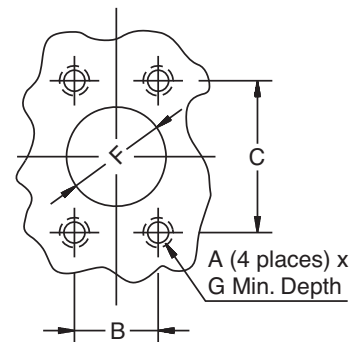

Seal Kits

Seal Kits are available for all piston accumulator models. When ordering seal kits, please supply the complete model and serial numbers from the name plate and specify fluid type and operating temperature.

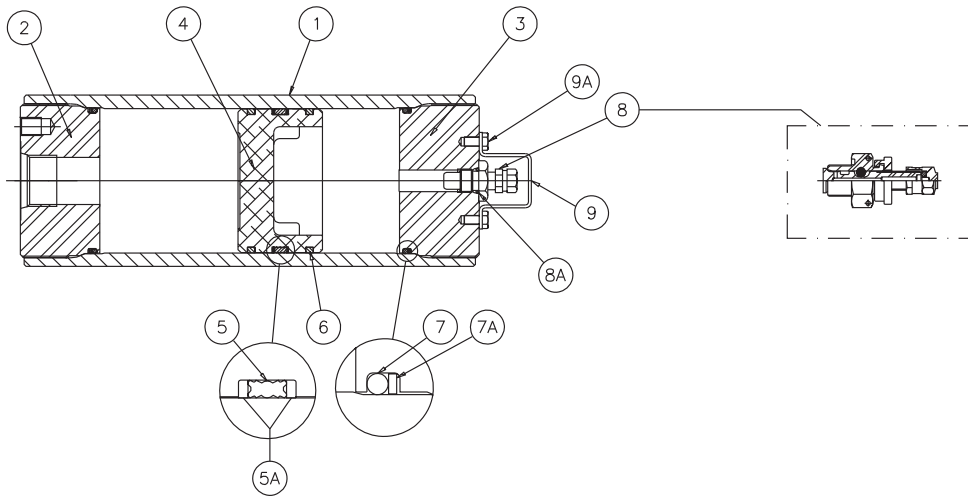

Parts List

- 1 Body
- 2 Hydraulic Cap
- 3 Gas Cap
- 4 Piston
- 5 V-O-ring Piston Seal
- 5A V-O-ring Backups
- 6 PTFE Glide Rings
- 7 O-ring
- 7A O-ring Backup
- 8 Gas Valve
- 8A Gas Valve O-ring
- 9 Gas Valve Guard
- 9A Screw

3000 PSI Seal Kit Numbers (Includes items 5, 5A, 6, 7, 7A, 8A)

Material	Bore Size						
	2"	3"	4"	6"	7"	9"	12"
Buna-Nitrile (Std.)	RK0200K000	RK0300K000	RK0400K000	RK0600K000	RK0700K000	RK0900K000	RK1200K000
Fluorocarbon	RK0200E000	RK0300E000	RK0400E000	RK0600E000	RK0700E000	RK0900E000	RK1200E000
EPR	RK0200D000	RK0300D000	RK0400D000	RK0600D000	RK0700D000	RK0900D000	CF*
Hydrogenated Nitrile	RK0200H000	RK0300H000	RK0400H000	RK0600H000	RK0700H000	RK0900H000	CF*
Low Temp Nitrile	RK0200Q000	RK0300Q000	RK0400Q000	RK0600Q000	RK0700Q000	RK0900Q000	RK1200Q000

*CF = Consult Factory

Mounting, Charging & Gauging Accessories

Parker offers a wide variety of mounting, charging and gauging accessories. See "Accumulator Accessories."



Special Options

If your application requires a piston accumulator, gas bottle, or special option that falls outside of Parker's broad offering, consult your local distributor, Parker representative, or the factory with your specific requirements. Parker has the manufacturing and engineering expertise to design and build piston accumulators to your exacting requirements, from simple modifications of standard units to complete designs. Some example of Parker's past special designs include:

- Large Bore
- High Pressure
- Special and Stainless Steel Materials
- Piston Position and Velocity Sensors and Switches
- Special Seals
- Non-Standard Capacities
- Tie Rod Construction
- Special Certifications
- Spring & Weight Loaded
- Extreme Temperatures

Consult the experts at Parker with your next piston accumulator requirement!

How to Order Piston Accumulators

Piston accumulators and gas bottles can be specified by using the symbols in the chart below to develop a model number. Select only those symbols that represent the features desired, and place them in the sequence indicated by the example at the top of the chart.

Series	Nominal Bore Size	Type of Construction	Options	Capacity	Design Pressure	Design Number	Seal Compound	Hyd. Port Modification	Gas Port Modification
A	7	K	-	2310	D	1	K	-	-

Series	
A Accumulator	B Gas Bottle

Nominal Bore Size	
3 3 inches	4 4 inches
6 6 inches	7 7 inches
9 9 inches	12 12 inches

Type of Construction	
N Threaded both ends non-A.S.M.E. mat'l standard on 2", 3", 4", 6", & 7" (3000 PSI fatigue design tested)	K Threaded both ends A.S.M.E. mat'l standard, NOT A.S.M.E. stamped on 7" & up
L Same as K with A.S.M.E. approval stamp 7" & up. Available as special on smaller sizes	E Threaded both ends, CE marked (1 liter and above) or SEP marked (under 1 liter)

Options	
Blank Standard Gas Cap	W Water Service
F SAE Fuse Port *	G SAE Fuse Port *, Water Service
M L07689000K Gas Valve	K L07689000K Gas Valve, Water Service
P SAE Fuse Port* and L07689000K	R SAE Fuse Port* and L07689000K, Water Service

Design Pressure	
D 3000 PSI (All Bore Sizes)	K 2000 PSI (12" Bore only)
X Other	
For CE Marked Only	
L 250 Bar (All Bore Sizes)	H 350 Bar (See page 50)

To order safety fuse and rupture disk installed on the accumulator add the rupture pressure to the end of the model number.

Example: A7LF2310D3KPL-3000. Rupture disks are available in 100 psi increments starting at 3000 psi.

Design Number	
1 Standard	2 Metric Mounting Holes & Hyd. Port (BSPP Standard) Specify Optional Ports
3 Optional Port (Hyd. or Gas, See Port Table)	*** Special Design

Bore Size/Capacity		
0029	29 cu. in. (0.48 liters)	
0058	58 cu. in. (0.95 liters)	
0090	90 cu. in. (1.47 liters)	3"
0116	116 cu. in. (1.90 liters)	
0183	183 cu. in. (3.00 liters)	
0058	58 cu. in. (0.95 liters)	
0116	116 cu. in. (1.90 liters)	
0231	1 gal. (3.79 liters)	4"
0347	1.5 gal. (5.69 liters)	
0578	2.5 gal. (9.47 liters)	
0231	1 gal. (3.79 liters)	
0347	1.5 gal. (5.69 liters)	
0578	2.5 gal. (9.47 liters)	
0924	4 gal. (15.1 liters)	6"
1155	5 gal. (18.9 liters)	
1733	7.5 gal. (28.4 liters)	
2310	10 gal. (37.9 liters)	
0578	2.5 gal. (9.47 liters)	
1155	5 gal. (18.9 liters)	
1733	7.5 gal. (28.4 liters)	7"
2310	10 gal. (37.9 liters)	
3465	15 gal. (56.8 liters)	
4620	20 gal. (75.7 liters)	9"
5775	25 gal. (94.6 liters)	
6930	30 gal. (113.6 liters)	
5775	25 gal. (94.6 liters)	
6930	30 gal. (114 liters)	12"
9240	40 gal. (151 liters)	
11550	50 gal. (189 liters)	

Consult factory for other available sizes.

Hydraulic and Gas Port Modifications Designated by 2 Digits			
1st Digit	Style	2nd Digit	Min. Bore Size
Blank	Std.	Blank	Std.
T	SAE Straight Thread Ports	A SAE #5 .5 - 20	3"
		B SAE #6 .562 - 18	3"
		C SAE #8 .75 - 16	3"
		D SAE #12 1.0625 - 12	3"
		E SAE #16 1.3125 - 12	3"
		F SAE #20 1.625 - 12	3"
		G SAE #24 1.875 - 12	4"
		H SAE #32 2.5 - 12	7"
		I SAE #10 .875 - 14	3"
P	Flange (Code 61)	J 1 1/2"	4"
		L 2"	6"
		M 2 1/2"	6"
M	Metric Flange per ISO 6162	N 3"	7"
		T 1/2"	3"
		U 3/4"	3"
		V 1"	3"
		W 1 1/4"	3"
U	NPTF (Not Recommended)	T 3/8"	3"
		U 1/2"	3"
		V 3/4"	3"
		W 1"	3"
		X 1 1/4"	3"
		Y 1 1/2"	4"
		Z 2"	4"
R	BSPP Parallel	BSPP/BSPT A 3/8 - 19	Metric/ISO 6149-1 A M14 x 1.5
B	BSPT Taper Port	B 1/2 - 14	B M18 x 1.5
G	Metric ISO 6149-1	C 3/4 - 14	C M22 x 1.5
		D 1 - 11	D M27 x 2
		E 1 1/4 - 11	E M33 x 2
		F 1 1/2 - 11	F M42 x 2
		G 2 - 11	G M48 x 2

Example of Optional Port Accumulator

A 4 N 0231 D 3 K T C U V

Non-std. Port SAE #8 Hyd. Port NPT 3/4" Gas Port

Standard Ports Available (See Port Modifications Table if Using Other Than Standard Ports Shown Below)		
Bore Size	Standard Port Sizes	Metric Port Sizes
3"	SAE #12	3/4
4"	SAE #20	1
6"	SAE #24	1
7"	SAE #32	ISO 6162
9"	SAE #32	ISO 6162
12"	3" SAE Flange Code 61	ISO 6162

Seal Compound (See Catalog for Temperature Settings)	
K Buna-Nitrile (Std)	E Fluoroelastomer
D EPD	H Hydrogenated Nitrile
Q Low Temp.	S Special (to be specified)



ACP Series Piston Accumulators

With Working Pressures of 3770, 4000 and 5000 PSI

IN THIS SECTION

Overview	37
Features & Benefits	38
Specifications	39
Models, Capacities & Dimensions	40
Ordering Information	41

Overview

- Higher working-pressure ratings (3770/4000/5000 PSI) meet more applications with fewer sizes needed
- Use of standard components promotes faster delivery of proven designs and lower product cost
- Piston design prevents sudden accumulator failure and is customized to fit the application
- Four bore sizes available for more capacity and price options
- Patented crimped end cap connections provide superior fatigue life compared with welded designs
- “Schrader” style gas valve (industry standard) fits existing charging equipment; “no gas valve” option also available
- Multiple hydraulic port sizes accommodate a wider range of fittings and mounting options.
- All standard product is CRN/CSA to -40° F/C



ACP Series accumulators are ideal for mobile equipment applications and harsh environments. Units are rated as listed below:

Nominal Bore Size (mm)	Working Pressure (PSI)	Design Factor
40	3770	3.5 to 1
50	4000	4 to 1
50	5000	4 to 1
80	4000	4 to 1
100	4000	4 to 1

The ACP product line has been tested and proven at temperatures of -40° F/C and meets or exceeds CSA/CE/ASME standards

Fluids Compatibility

Parker's seal compounds are compatible with a wide variety of fluids. Standard accumulators (with nitrile seals) may be used with petroleum-based industrial oils or water-based, flame-resistant fluids. Optional seals compatible with most industrial fluids are available with temperature ranges from -45°F to 320°F (-43°C to 160°C).

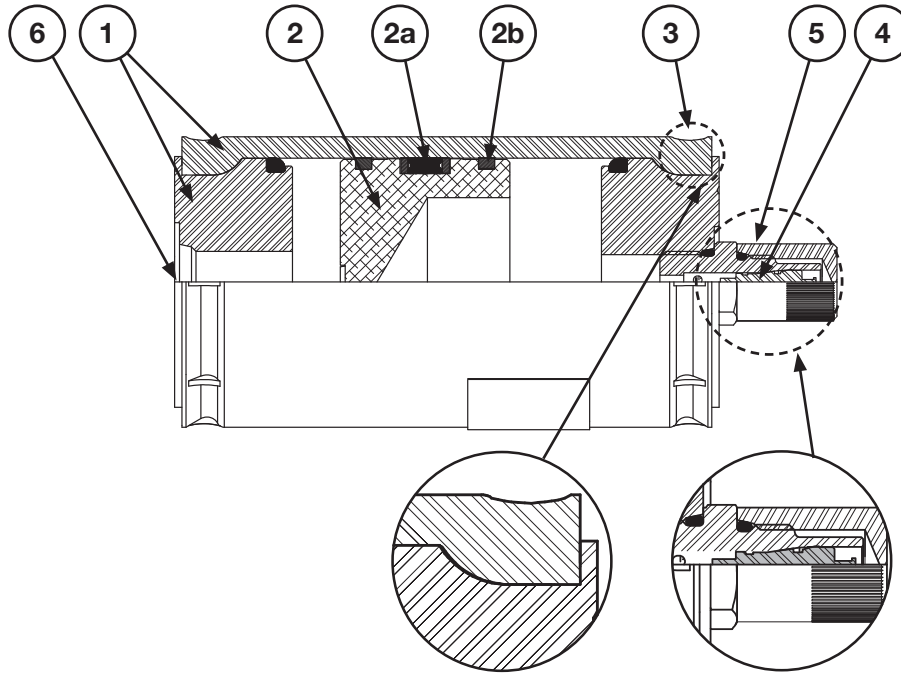

- 1 High-strength, compact steel shell and cap material** steel shell allows heat to dissipate effectively and is micro-finished for extended seal life.
- 2 Lightweight piston design** allows for fast response to reduce system shock in rapid cycling applications.
- 2a Piston seal's unique, five-bladed V-O-ring** with back-up washers eliminates seal roll-over and ensures total separation of fluid and gas (40 mm size incorporates a T-seal with energized PTFE piston ring).
- 2b PTFE glide rings** eliminate metal-to-metal contact between tube and piston, reducing wear and extending service life.

- 3 Patented crimped design** provides high-strength coupling of caps to steel tube plus superior fatigue life versus welded type connections.
- 4 "Schrader" style gas valve** is standard on all ACP accumulators for ease of precharging. (Pre-charged accumulators are available featuring specially designed threaded plug and no gas valve option.)
- 5 Gas valve cap** protects valve and serves as secondary seal. Knurled cap design allows easy installation without tools.
- 6 Port types** are available in a wide range of female sizes in both SAE and BSPP styles.

Actual Bore Sizes & Maximum Flow Rates

Nominal Bore Size (mm)	Actual Bore Size		Max. Recommended Flow*	
	(in)	(mm)	GPM	LPM
40	1.50	38.20	55	209
50	2.02	51.44	100	380
80	3.00	76.20	220	834
100	4.03	102.4	397	1504

*Note: Based on 120 in/sec maximum piston speed, port & fitting size will become limiting factors for most applications.

Gas Valves Options

ACP Series accumulators are available either with the industry-standard “Shrader” style gas valve for ease of precharging or poppet style valve (L07689000).

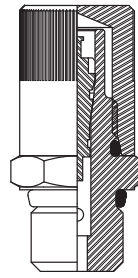

870636H0QQ

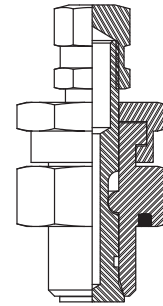

L07689000*

Seal Material Options

Seal Code	Polymer	**Recommended Operating Temperature Range	Maximum Temperature with Reduced Life	General Application and Compatibility*
K	Buna-Nitrile	-20°F to 165°F -29°C to 74°C	200°F 93°C	Parker's Standard Compound – Compatible with most mineral oil-based fluids
E	Fluorocarbon Elastomer	-10°F to 250°F -23°C to 121°C	400°F 204°C	Compatible with most mineral oil-based fluids at higher temperatures and some exotic fluids
H	Hydrogenated Nitrile	-25°F to 320°F -32°C to 160°C	350°F 177°C	Compatible with most oil-based and biodegradable fluids, maintains sealing effectiveness at a wide range of temperatures
Q	Low Temp. Nitrile	-45°F to 160°F -43°C to 71°C	200°F 93°C	Compatible with most mineral oil-based fluids and maintains sealing effectiveness at low temperatures

*Consult local distributor or factory for fluid compatibility information.

**The temperatures listed indicate the operating temperature range of the seals, not the accumulator.

Mounting, Charging & Gauging Accessories

Parker offers a wide variety of mounting, charging and gauging accessories. See “Accumulator Accessories.”



**3,770 PSI (260 Bar Metric) &
 4,000 PSI (275 Bar Metric)
 Crimped Piston Accumulator with Gas Valve**

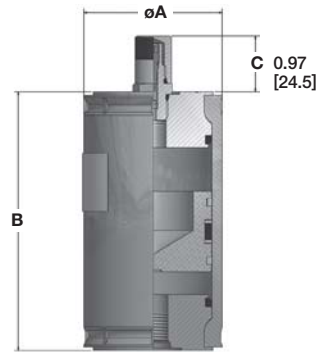

	Model Number	Fluid Volume		Gas Volume		Diameter	Estimated Length	Estimated Dry Weight	
		Liters	cu. in.	Liters	cu. in.	øA in (mm)	B in (mm)	LBS	(Kg)
3,770 PSI MODELS									
40 mm BORE	ACP04AA002R1KTB	0.02	0.92	0.02	1.2	1.74 (44.1)	3.02 (76.6)	2	0.91
	ACP04AA008R1KTB	0.08	4.58	0.08	4.9		5.08 (129.2)	2	0.91
	ACP04AA016R1KTB	0.15	9.46	0.16	9.8		7.84 (199.2)	2	0.91
	ACP04AA032R1KTB	0.31	19.23	0.32	19.5		13.36 (339.3)	3	1.36
4,000 PSI MODELS									
50 mm BORE	ACP05AA008E1KTC	0.06	3.67	0.08	4.9	2.38 (60.3)	4.47 (113.5)	4	1.81
	ACP05AA016E1KTC	0.14	8.55	0.16	9.8		5.98 (151.9)	4	1.81
	ACP05AA032E1KTC	0.30	18.31	0.32	19.5		9.01 (228.9)	5	2.27
	ACP05AA050E1KTC	0.48	29.3	0.50	30.5		12.43 (315.7)	6	2.72
	ACP05AA075E1KTC	0.73	44.55	0.75	45.8		17.16 (435.9)	5	2.27
	ACP05AA100E1KTC	0.93	56.76	0.95	58.0		20.95 (532.1)	9	4.08
80 mm BORE	ACP08AA032E1KTI	0.25	15.44	0.32	19.5	3.56 (90.4)	6.73 (171.0)	11	4.99
	ACP08AA050E1KTI	0.43	26.48	0.50	30.5		8.29 (210.5)	13	5.90
	ACP08AA075E1KTI	0.68	41.73	0.75	45.8		10.45 (265.4)	14	6.35
	ACP08AA100E1KTI	0.88	53.94	0.95	58.0		12.18 (309.3)	16	7.26
	ACP08AA150E1KTI	1.43	87.5	1.50	91.5		16.93 (430.0)	20	9.07
	ACP08AA200E1KTI	1.93	118.01	2.00	122.1		21.25 (539.7)	23	10.43
100 mm BORE	ACP10AA075E1KTD	0.59	36.16	0.75	45.8	4.76 (120.9)	8.47 (215.2)	25	11.34
	ACP10AA100E1KTD	0.79	48.37	0.95	58.0		9.43 (239.5)	26	11.79
	ACP10AA150E1KTD	1.34	81.83	1.50	91.5		12.06 (306.4)	30	13.61
	ACP10AA200E1KTD	1.84	112.44	2.00	122.1		14.46 (367.2)	33	14.97
	ACP10AA300E1KTD	2.84	173.46	3.00	183.1		19.24 (488.7)	40	18.14
	ACP10AA400E1KTD	3.84	234.49	4.00	244.1		24.03 (310.3)	47	21.31
	ACP10AA600E1KTD	5.84	356.54	6.00	366.1		33.60 (853.4)	60	27.21
	ACP10AA800E1KTD	7.84	478.58	8.00	488.2		43.17 (1096.6)	74	33.56

**5,000 PSI (345 Bar Metric)
 Crimped Piston Accumulator with Gas Valve**

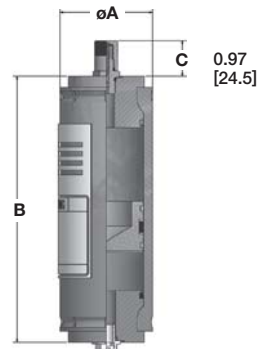

	Model Number	Fluid Volume		Gas Volume		Diameter	Estimated Length	Estimated Dry Weight	
		Liters	cu. in.	Liters	cu. in.	øA in (mm)	B in (mm)	LBS	(Kg)
50 mm BORE	ACP05AA008C1KTC	0.06	3.67	0.08	4.9	2.50 (63.5)	5.71 (145.1)	6	2.72
	ACP05AA016C1KTC	0.14	8.55	0.16	9.8		7.23 (183.6)	6	2.72
	ACP05AA032C1KTC	0.30	18.31	0.32	19.5		10.26 (260.6)	8	3.63
	ACP05AA050C1KTC	0.48	29.3	0.50	30.5		13.67 (347.3)	8	3.63
	ACP05AA075C1KTC	0.73	44.55	0.75	45.8		18.41 (467.6)	12	5.44
	ACP05AA100C1KTC	0.93	56.76	0.95	58.0		22.20 (563.8)	13	5.90

How to Order ACP Series Piston Accumulators

Piston accumulators and gas bottles can be specified by using the symbols in the chart below to develop a model number. Select only those symbols that represent the features desired, and place them in the sequence indicated by the example at the top of the chart.

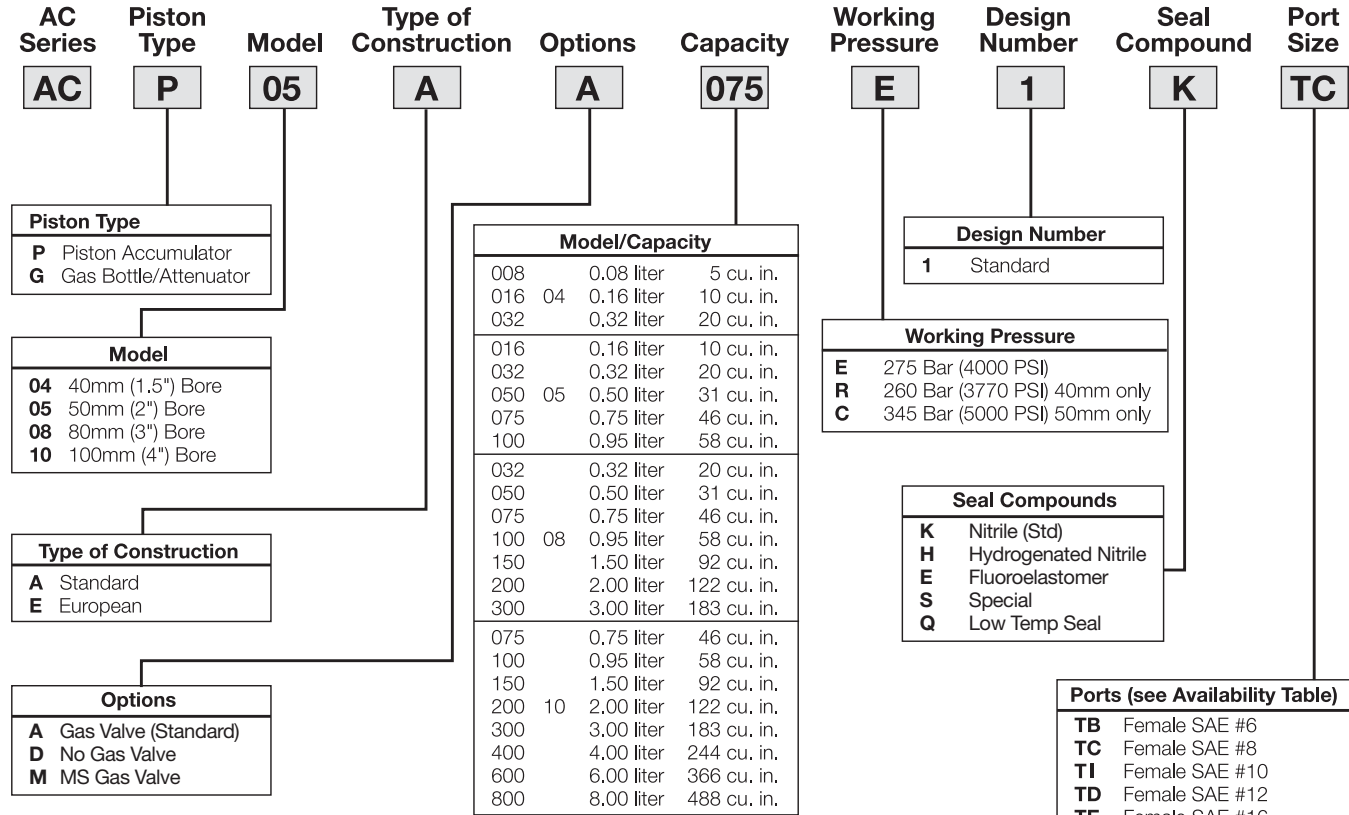

Port Availability

Model	Female SAE					Female BSPP			
	6	8	10	12	16	3/8	1/2	3/4	1
04	•					•	★		
05	★	•	★	★	†	★	★	•	
08	★	★	•	★	★†	★	★	★	•
10	★	★	★	•	★†	★	★	★	•

• = Standard ★ = Optional

† For SAE 16 and CE together, consult factory

Notes

Series 4000 & 5000 Piston Accumulators

IN THIS SECTION

Overview	43
Specifications	44
Options	45
Models, Capacities & Dimensions	
Series 4000	46
Series 5000	47
Port Options	48
Parts & Accessories	49
Ordering Information	50

Features

- Heavy Duty Service with 4000 to 5000 PSI Operating Pressure
- 3" thru 9" Bores with Over 20 Standard Capacities
- V-O-ring Piston Seals
- Serviceable Threaded End Construction
- Five Standard Seal Options to Handle a Variety of Fluids & Temperatures
- Certifications Available: ASME, DNV, ABS, AS1210, SELO, CRN, GOST, CE
- Temperature Ranges -45° to 320°F



Materials

- Shell – high strength steel
- Caps – steel
- Pistons – aluminum
- Gas Valve Cartridge – stainless steel
- Gas Valve Protector – steel
- Piston Glide Rings – PTFE
- Piston & End Seals – various polymers
- Piston Seal Backups – PTFE

Actual Bore Sizes & Maximum Flow Rates

Nominal Bore Size (in)	Actual Bore Size		Max. Recommended Flow*	
	(in)	(mm)	GPM	LPM
3	3.00	76.20	220	834
4	4.03	102.4	397	1504
6	5.78	146.9	818	3096
7	7.00	178	1199	4538
9	9.00	229	1982	7502

*Note: Based on 120 in/sec maximum piston speed, port & fitting size will become limiting factors for most applications.

Pressure Ratings

Parker 4000 & 5000 PSI piston accumulators are all rated at minimum 4 to 1 design factors.

Fluids

Parker’s piston accumulators are compatible with a wide variety of fluids. Standard accumulators (with nitrile seals) may be used with petroleum-based industrial oils or water-based flame resistant fluids. Optional seals compatible with most industrial fluids are available with temperature ranges from -45°F to 320°F (-43°C to 160°C).

Precharge

Units are shipped with a nominal nitrogen precharge as standard. For specific precharge pressures, specify at the time of order.

Standard Ports

The following ports are supplied as standard on all fluid ends and on the gas end of accumulators ordered for use with gas bottles:

Bore Size	Standard Ports	
	Standard Models SAE Port	Metric Models BSPP Port (in)
3	SAE #12	3/4
4	SAE #16	1
6	SAE #16	1
7	2" Code 62 Flange	2" Metric ISO 6162 Flange
9	2" Code 62 Flange	2" Metric ISO6162 Flange

Gas Valve

Series 4000 accumulators and auxiliary gas bottles are equipped with a high pressure cored gas valve cartridge as standard.

Series 5000 accumulators and gas bottles with 3" through 6" bores are supplied with a high pressure cored gas valve as standard. Models with 7" and 9" bores are supplied with a heavy duty, high-pressure, poppet-type gas valve cartridge (L07689000K) as standard.

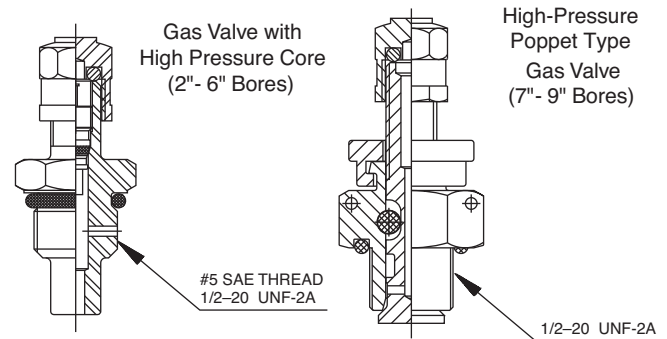

Note: The standard Parker gas cap will accept either style gas valve.

Available Options

If your application requires a piston accumulator, gas bottle, or special option that falls outside of Parker’s broad offering, consult your local distributor, Parker representative, or the factory with your specific requirements. Parker has the manufacturing and engineering expertise to design and build piston accumulators to your exacting requirements, from simple modifications of standard units to complete designs. Some example of Parker’s past special designs include:

- Special and Stainless Steel Materials
- High Pressures
- Extreme Temperatures
- Piston Position and Velocity Sensors and Switches
- Special Seals
- Non-Standard Capacities
- Water Service
- Ports
- Fixed Gauge Mounts
- Fuse Plug Assemblies

Auxiliary Gas Bottles

When space does not permit the installation of the required piston accumulator, a smaller accumulator may be used by connecting it to an auxiliary gas bottle(s) that can be located in a nearby spot where space is available. In some cases, a piston accumulator and gas bottle combination may be more economical, especially large capacity sizes. Piston travel, confined to the accumulator, must be calculated with ample margins to store the required fluid.

Gas Valve Option (M) - Series 4000 & 5000

3" thru 6" Bore Sizes

A heavy duty, high-pressure, poppet-type gas valve cartridge (L07689000K) is available as an option (M) – specify when ordering.

Note: This valve is standard on 7" and 9" bore sizes.

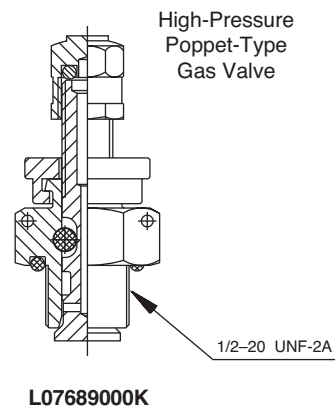

Seal Material Options

Seal Code	Polymer	Recommended Operating Temperature Range	Maximum Temperature with Reduced Life	General Application and Compatibility*
K	Buna Nitrile	-20°F to 165°F -29°C to 74°C	200°F 93°C	Parker's Standard Compound – Compatible with most mineral oil-based fluids
E	Fluorocarbon Elastomer	-10°F to 250°F -23°C to 121°C	400°F 204°C	Compatible with most mineral oil-based fluids at higher temperatures and some exotic fluids
D	Ethylene Propylene	-40°F to 250°F -40°C to 121°C	300°F 149°C	Compatible with most phosphate ester fluids and some synthetic fluids
H	Hydrogenated Nitrile	-25°F to 320°F -32°C to 160°C	350°F 177°C	Compatible with most oil-based and biodegradable fluids, maintains sealing effectiveness at a wide range of temperatures
Q	Low Temp. Nitrile	-45°F to 160°F -43°C to 71°C	200°F 93°C	Compatible with most mineral oil-based fluids and maintains sealing effectiveness at low temperatures

*Consult local distributor or factory for fluid compatibility information. Temperature ranges may vary depending upon fluid used in hydraulic system.

**The temperature listed indicates the operating temperature range of the seals, not the accumulator. For the Minimum Design Metal Temperature (MDMT) of ASME certified accumulators, refer to page 47.

Safety Fuse Options (F)

Safety Fuses are used as a safety device on accumulators and gas bottles to prevent over-pressurization of gas due to external heat or hydraulic pressure (set at 140% of maximum system pressure to avoid rupture disk fatigue and premature failure). The rupture disks are calibrated to rupture at a pre-determined pressure. Safety fuses are available on most sizes of piston accumulators. Safety fuses can be installed on all piston accumulators by using a fuse adapter. 4" bore units and above can be equipped with a fuse port machined in the gas cap by specifying the "Safety Fuse Option" (F) at the time of order in the model code, see "How to Order." The safety fuse assembly and/or fuse adapter must be ordered separately.

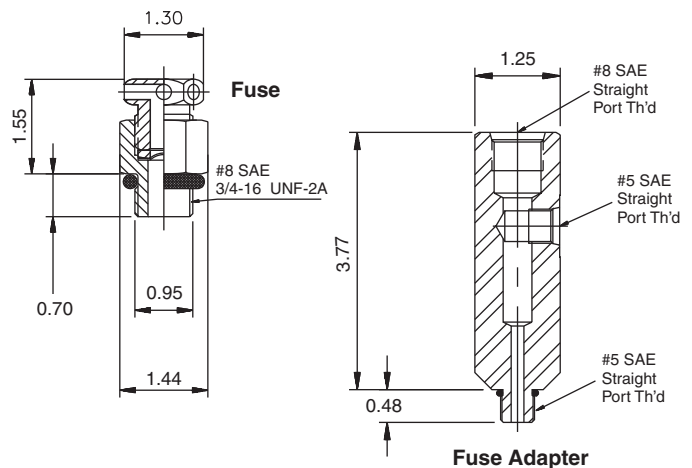

Description	Part Number
Safety Fuse Assembly ¹	086471xxxx
Replacement Rupture Disks	756003xxxx
Fuse Adapter	1468970002

¹ Assembly includes housing and rupture disk, xxxx = pressure setting in 100 PSI increments, i.e., for an assembly with a 2000 PSI setting, order P/N 0864712000.

Note: ASME and CRN units available upon request.

4000 PSI (276 Bar Metric) Piston Accumulators for Oil and Water Service

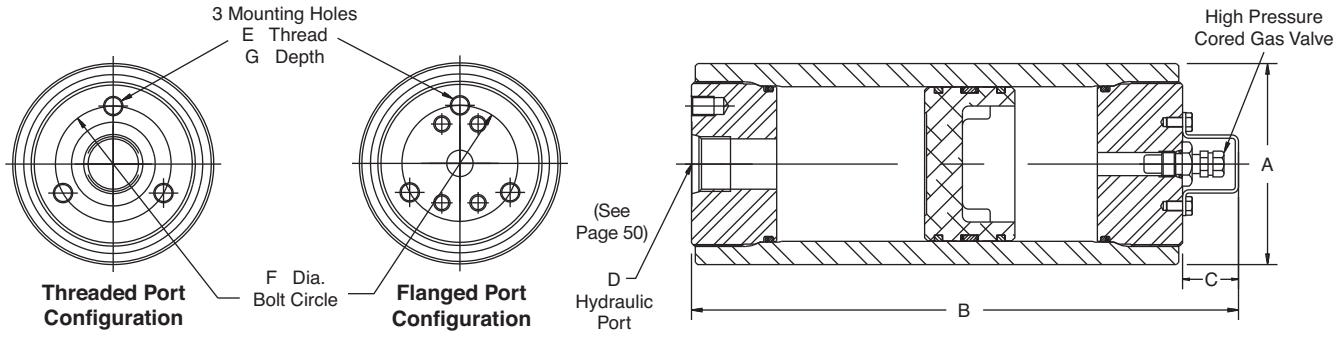

Model No.	Fluid Volume		Gas Volume		A in (mm)	B (in)	C in (mm)	E in (mm)	F in (mm)	G in (mm)	Weight lbs (Kg)
	Oil Service (cu in)	gal (Liters)	cu in	(Liters)							
A2N0005E1K (E2K)	5	(0.08)	6.5	(0.11)	2.50 (64)	6.76 (172)	1.06 (27)	-	-	-	6 (2.7)
A2N0010E1K (E2K)	10	(0.16)	11.5	(0.19)		8.31 (211)					6 (2.7)
A2N0015E1K (E2K)	15	(0.25)	16.5	(0.24)		9.78 (250)					7 (3.2)
A2N0029E1K (E2K)	29	1 Pint (0.48)	30.5	(0.50)		14.19 (360)					9 (4.1)
A2N0058E1K (E2K)	58	1 Quart (0.95)	59.5	(0.98)		23.19 (589)					14 (6.1)
A3N0029E1K (E2K)	29	1 Pint (0.48)	34	(0.56)	3.75 (96)	10.25 (260)	3/8 - 24 (M10)	2.25 (60)	0.56 (15)	-	17 (7.8)
A3N0058E1K (E2K)	58	1 Quart (0.95)	63	(1.03)		14.34 (364)					25 (11.1)
A3N0090E1K (E2K)	90	1.5 Quart (1.42)	95	(1.56)		18.94 (481)					33 (14.8)
A3N0116E1K (E2K)	116	1/2 Gal. (1.90)	121	(1.98)		22.56 (573)					39 (17.7)
A3N0183E1K (E2K)	183	3 Quart (2.84)	188	(3.08)		32.06 (814)					56 (25.4)
A4N0058E1K (E2K)	58	1 Quart (0.95)	68	(1.11)	5.00 (127)	12.06 (306)	1/2 - 20 (M12)	3.25 (82)	0.75 (18)	-	37 (16.6)
A4N0116E1K (E2K)	116	1/2 Gal. (1.90)	126	(2.06)		16.62 (422)					46 (20.6)
A4N0231E1K (E2K)	231	1 Gal. (3.79)	241	(3.95)		25.62 (651)					63 (28.7)
A4N0347E1K (E2K)	347	1-1/2 Gal. (5.69)	357	(5.85)		34.75 (883)					81 (36.8)
A4N0578E1K (E2K)	578	2-1/2 Gal. (9.47)	588	(9.64)		52.81 (1341)					117 (53.0)
A6N0231E1K (E2K)	231	1 Gal. (3.79)	266	(4.36)	7.06 (180)	19.18 (487)	1/2 - 20 (M12)	4.38 (110)	0.75 (18)	-	110 (49.8)
A6N0347E1K (E2K)	347	1-1/2 Gal. (5.69)	382	(6.26)		23.62 (600)					126 (57.2)
A6N0578E1K (E2K)	578	2-1/2 Gal. (9.47)	613	(10.0)		32.43 (824)					158 (71.9)
A6N0924E1K (E2K)	924	4 Gal. (15.1)	959	(15.70)		45.62 (1159)					207 (93.9)
A6N1155E1K (E2K)	1155	5 Gal. (18.9)	1190	(19.50)		54.43 (1383)					239 (109)
A6N1733E1K (E2K)	1733	7-1/2 Gal. (28.4)	1768	(29.00)		76.43 (1941)					320 (145)
A6N2310E1K (E2K)	2310	10 Gal. (37.9)	2345	(38.40)		98.43 (2500)					401 (182)

Notes:

- For Water Service add "W" after construction code, see "How to Order" information.
- Standard accumulators are designated E1K in model number, metric are E2K.
- See "Port Options" for complete listing of standard and optional ports.
- When accumulators are to be used with gas bottles, order "Accumulators for Use with Gas Bottles."

5000 PSI (345 Bar Metric) Piston Accumulators for Oil and Water Service

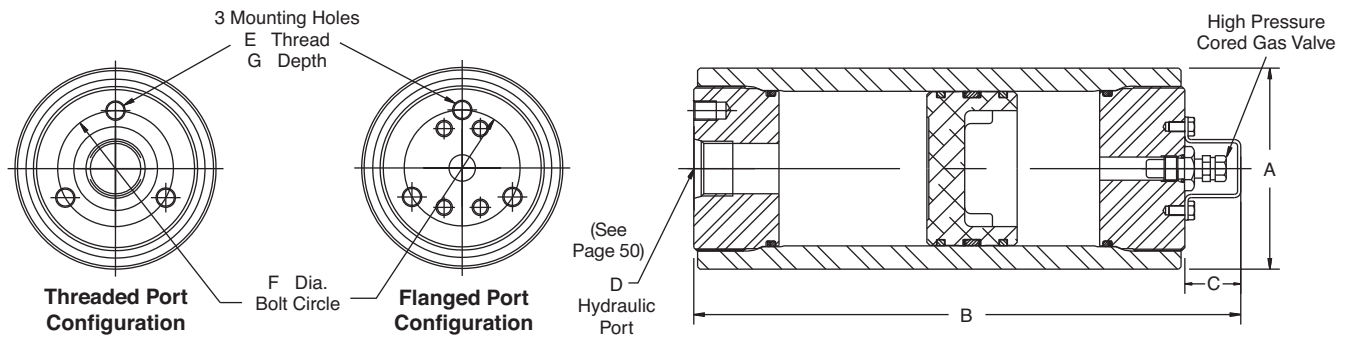

Model No.	Fluid Volume		Gas Volume		A in (mm)	B in (mm)	C in (mm)	E in (mm)	F in (mm)	G in (mm)	Weight lbs (Kg)
	Oil Service (cu in)	Gal (Liters)	cu in	(Liters)							
A2N0005C1K (C2K)	5	(0.08)	6.5	(0.11)	2.63 (67)	6.76 (172)	1.06 (27)	-	-	-	6 (2.8)
A2N0010C1K (C2K)	10	(0.16)	11.5	(0.19)		7 (3.2)					
A2N0015C1K (C2K)	15	(0.25)	16.5	(0.24)		8 (3.7)					
A2N0029C1K (C2K)	29	1 Pint (0.48)	30.5	(0.50)		11 (5.0)					
A2N0058C1K (C2K)	58	1 Quart (0.95)	59.5	(0.98)		17 (7.6)					
A3N0029C1K (C2K)	29	1 Pint (0.48)	34	(0.56)	4.00 (102)	10.25 (260)	3/8 - 12 (M10)	2.25 (60)	0.56 (15)	21 (9.6)	
A3N0058C1K (C2K)	58	1 Quart (0.95)	63	(1.03)		28 (12.5)					
A3N0090C1K (C2K)	90	1.5 Quart (1.47)	95	(1.56)		35 (15.7)					
A3N0116C1K (C2K)	116	1/2 Gal. (1.90)	121	(1.98)		40 (18.3)					
A3N0183C1K (C2K)	183	3 Quart (3.00)	188	(3.08)		55 (25.0)					
A4N0058C1K (C2K)	58	1 Quart (0.95)	68	(1.11)	5.25 (134)	12.06 (306)	1/2 - 20 (M12)	3.25 (82)	0.75 (18)	43 (19.4)	
A4N0116C1K (C2K)	116	1/2 Gal. (1.90)	126	(2.06)		54 (24.6)					
A4N0231C1K (C2K)	231	1 Gal. (3.79)	241	(3.95)		77 (34.9)					
A4N0347C1K (C2K)	347	1-1/2 Gal. (5.69)	357	(5.85)		100 (45.4)					
A4N0578C1K (C2K)	578	2-1/2 Gal. (9.47)	588	(9.64)		146 (66.2)					
A6N0231C1K (C2K)	231	1 Gal. (3.79)	266	(4.36)	7.50 (191)	19.18 (487)	1/2 - 20 (M12)	4.38 (110)	0.75 (18)	128 (57.9)	
A6N0347C1K (C2K)	347	1-1/2 Gal. (5.69)	382	(6.26)		148 (67.3)					
A6N0578C1K (C2K)	578	2-1/2 Gal. (9.47)	613	(10.00)		190 (86.0)					
A6N0924C1K (C2K)	924	4 Gal. (15.10)	959	(15.70)		252 (114)					
A6N1155C1K (C2K)	1155	5 Gal. (18.90)	1190	(19.50)		293 (133)					
A6N1733C1K (C2K)	1733	7-1/2 Gal. (28.40)	1768	(29.00)		396 (180)					
A6N2310C1K (C2K)	2310	10 Gal. (37.90)	2345	(38.40)		499 (227)					
A7K1155C1K (C2K)	1155	5 Gal. (18.90)	1190	(19.50)		9.09				42.50 (1080)	5/8 - 18 (M16)
A7K1733C1K (C2K)	1733	7-1/2 Gal. (28.40)	1768	(29.00)	±0.06	57.50 (1461)	495 (226)				
A7K2310C1K (C2K)	2310	10 Gal. (37.90)	2345	(38.40)	(231.1	72.50 (1842)	611 (277)				
A7K3465C1K (C2K)	3465	15 Gal. (56.85)	3520	(57.75)	±1.5)	102.50 (2604)	837 (380)				
A9K2310C1K (C2K)	2310	10 Gal. (37.90)	2400	(39.37)	11.78 ±0.09 (299.2 ±2.3)	50.75 (1289)	3/4-16 (M19)	7.00 (178)	1.13 (29)	831 (377)	
A9K3465C1K (C2K)	3465	15 Gal. (56.85)	3555	(58.33)		1064 (483)					
A9K4620C1K (C2K)	4620	20 Gal. (75.80)	4710	(77.27)		1298 (589)					
A9K5775C1K (C2K)	5775	25 Gal. (94.75)	5865	(96.23)		1532 (695)					
A9K6930C1K (C2K)	6930	30 Gal. (113.70)	7020	(115.18)		1765 (801)					

The Minimum Design Metal Temperature (MDMT) for ASME certified piston accumulators presented in this section is 20°F (-7°C).

Notes:

- For Water Service add "W" after construction code, see "How to Order" information.
- Standard accumulators are designated C1K in model number, metric are C2K.
- See "Port Options" for complete listing of standard and optional ports.

- ASME/DNV/ABS/AS1210/SELO/CRNI/GOST/CE certified accumulators and gas bottles are available.
- 2", 3", 4" & 6" bores standard with cored gas valves. Poppet type (L07689000K) gas valve available as an option.

Optional Ports

The following ports are available as options on all piston accumulators.

SAE Straight Thd.			Code 62 Flange				NPT			BSPP			ISO 6149-1		
Port Size	Port Code	Min. Bore	Port Size	Port Code		Min. Bore	Port Size	Port Code	Min. Bore	Port Size	Port Code	Min. Bore	Port Size	Port Code	Min. Bore
				Inch	Metric										
#5	TA	3"	1"	PG	MG	4"	3/8"	UT	3"	3/8"	RA	3"	M14	YA	3"
#6	TB	3"	1¼"	PH	MH	4"	1/2"	UU	3"	1/2"	RB	3"	M18	YB	3"
#8	TC	3"	1½"	PP	MV	6"	3/4"	UV	3"	3/4"	RC	3"	M22	YC	3"
#10	TI	3"	2"	PQ	MQ	6"	1"	UW	3"	1"	RD	3"	M27	YD	3"
#12	TD	3"	2½"	PR	—	7"	1¼"	UX	3"	1¼"	RE	3"	M33	YE	3"
#16	TE	3"	3"	PS	—	9"	1½"	UY	4"	1½"	RF	4"	M42	YF	3"
—	—	—	—	—	—	—	2"	UZ	4"	2"	RG	4"	—	—	—

Notes:

- 1" thru 2" flanges are to standard SAE Code 62 dimensions, 2-1/2" to "Socket Weld Flange Adapter Pattern", dimensions are shown below. Metric pattern supplied on 276 Bar Metric units unless otherwise specified.
- BSPT and Metric ports available, consult factory.

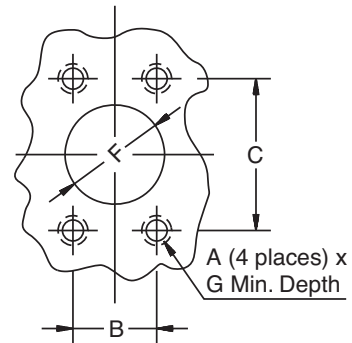

SAE 4-Bolt Flange Dimensions

Code 62 (ISO 6162) (thru 2" diameter) – 6000 PSI (410 Bar)

Flange Size		SAE Flange Dimensions (in)					Metric SAE Flange Dimensions (mm)				
in	mm	A	B	C	F	G	A	B	C	F	G
1½"	38	5/8 - 11	1.438	3.125	1½	1.375	M16	36.5	79.4	38	34.9
2"	50	3/4 - 10	1.750	3.812	2	1.500	M20	44.5	96.8	50	38.1
2½"	—	7/8 - 9	2.312	4.875	2½	1.625	—	—	—	—	—

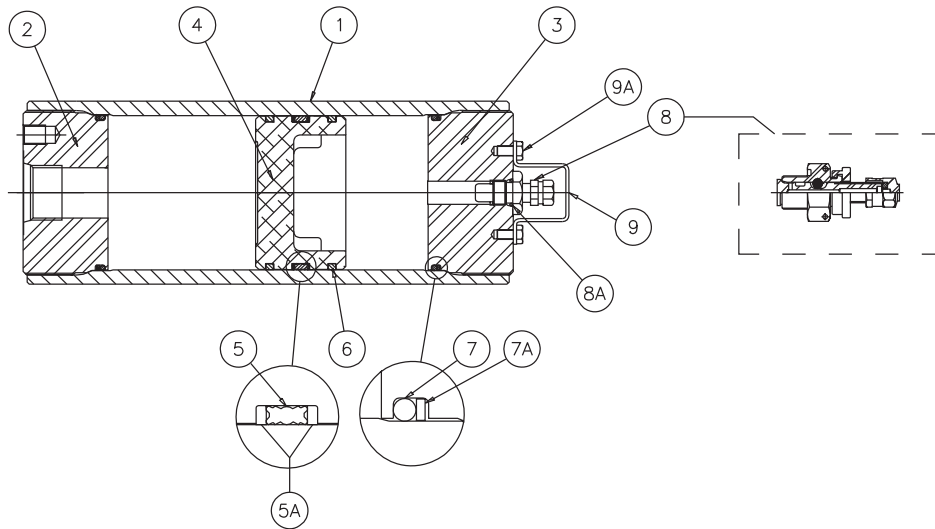

Item Part Description

- 1 Body
- 2 Hydraulic Cap
- 3 Gas Cap
- 4 Piston
- 5 V-O-Ring
- 5A V-O-Ring Back-Up Washers
- 6 PTFE Ring (Piston)
- 7 O-Ring
- 7A O-Ring Back-Up Washer
- 8 Gas Valve
- 8A Gas Valve O-Ring
- 9 Gas Valve Guard
- 9A Screw

4000 & 5000 PSI Seal Kit Numbers (Includes items 5, 5A, 6, 7, 7A, 8A)

Material	Bore Size					
	2"	3"	4"	6"	7"	9"
Buna-Nitrile (Std.)	RK0200K000	RK0300K000	RK0400K000	RK0600K000	RK0700K000	RK0900K000
Fluorocarbon	RK0200E000	RK0300E000	RK0400E000	RK0600E000	RK0700E000	RK0900E000
EPR	RK0200D000	RK0300D000	RK0400D000	RK0600D000	RK0700D000	RK0900D000
Hydrogenated Nitrile	RK0200H000	RK0300H000	RK0400H000	RK0600H000	RK0700H000	RK0900H000
Low Temp Nitrile	RK0200Q000	RK0300Q000	RK0400Q000	RK0600Q000	RK0700Q000	RK0900Q000

Mounting, Charging & Gauging Accessories

Parker offers a wide variety of mounting, charging and gauging accessories. See "Accumulator Accessories."

Charging Kit Part No. 870816 5000

Standard Assembly LH Connection with 5000 PSI Gauge



Special Options

If your application requires a piston accumulator, gas bottle, or special option that falls outside of Parker's broad offering, consult your local distributor, Parker representative, or the factory with your specific requirements. Parker has the manufacturing and engineering expertise to design and build piston accumulators to your exacting requirements, from simple modifications of standard units to complete designs. Some example of Parker's past special designs include:

- High Pressure
- Special and Stainless Steel Materials
- Piston Position and Velocity Sensors and Switches
- Special Seals
- Non-Standard Capacities
- Tie Rod Construction
- Special Certifications
- Spring & Weight Loaded
- Extreme Temperatures
- Water Service

Consult the experts at Parker with your next piston accumulator requirement!

How to Order Piston Accumulators

Piston accumulators can be specified by using the symbols in the chart below to develop a model number. Select only those symbols that represent the features desired, and place them in the sequence indicated by the example at the top of the chart.

Series	Nominal Bore Size	Type of Construction	Options	Capacity	Design Pressure	Design Number	Seal Compound	Hyd. Port Modification	Gas Port Modification
A	7	K	-	2310	C	1	K	-	-

Series	
A	Accumulator
B	Gas Bottle

Nominal Bore Size	
3	3 inches
4	4 inches
6	6 inches
7	7 inches
9	9 inches

Type of Construction	
N	Threaded both ends non-ASME mat'l standard on 2", 3", 4", 6"
K	Threaded both ends A.S.M.E. mat'l standard, NOT A.S.M.E. stamped on 7" & up
L	Same as K with A.S.M.E. approval stamp 7" & up. Available as special on smaller sizes
E	Threaded both ends, CE marked (1 liter and above) or SEP marked (under 1 liter)

Bore Size/Capacity		
0029		29 cu. in. (0.48 liters)
0058		58 cu. in. (0.95 liters)
0090	3"	90 cu. in. (1.47 liters)
0116		116 cu. in. (1.90 liters)
0183		183 cu. in. (3.00 liters)
0058		58 cu. in. (0.95 liters)
0116		116 cu. in. (1.90 liters)
0231	4"	1 gal. (3.79 liters)
0347		1.5 gal. (5.69 liters)
0578		2.5 gal. (9.47 liters)
0231		1 gal. (3.79 liters)
0347		1.5 gal. (5.69 liters)
0578		2.5 gal. (9.47 liters)
0924	6"	4 gal. (15.1 liters)
1155		5 gal. (18.9 liters)
1733		7.5 gal. (28.4 liters)
2310		10 gal. (37.9 liters)
1155		5 gal. (18.9 liters)
1733	7"	7.5 gal. (28.4 liters)
2310		10 gal. (37.9 liters)
3465		15 gal. (56.8 liters)
2310		10 gal. (37.9 liters)
3465		15 gal. (56.8 liters)
4620	9"	20 gal. (75.8 liters)
5775		25 gal. (94.6 liters)
6930		30 gal. (114 liters)

Consult factory for other available sizes.

Design Pressure	
C	5000 PSI
E	4000 PSI
H	350 Bar (CE marked only)

To order safety fuse and rupture disk installed on the accumulator add the rupture pressure to the end of the model number.

Example: A7LF2310D3KPL-3000.
Rupture disks are available in 100 psi increments starting at 3000 psi.

Design Number	
1	Standard Ports
2	Metric Mounting Holes & Hyd. Port (BSPP/Metric Flange Standard) Specify Optional Ports
3	Optional Port (Hyd. or Gas, See Port Modifications Table)
***	Special Design

Hydraulic and Gas Port Modifications Designated by 2 Digits				
1st Digit	Style	2nd Digit	Description	Min. Bore
Blank	Std.	Blank	Std.	
T	SAE Straight Thread Ports	A	SAE #5 (1/2 - 20)	2"
		B	SAE #6 (9/16 - 18)	2"
		C	SAE #8 (3/4 - 16)	2"
		D	SAE #12 (1 1/16 - 12)	2"
		E	SAE #16 (1 5/16 - 12)	3"
		F	SAE #20 (1 5/8 - 12)	3"
		G	SAE #24 (1 7/8 - 12)	4"
		H	SAE #32 (2 1/2 - 12)	7"
		I	SAE #10 (7/8 - 14)	2"
P	Flange Code 62	F	3/4"	4"
		G	1"	4"
		H	1 1/4"	4"
M	Metric Flange per ISO 6162	P	1 1/2"	6"
		Q	2"	6"
		R*	2 1/2"	7"
		S*	3"	9"
U	NPTF (Not Recommended)	T	3/8"	2"
		U	1/2"	2"
		V	3/4"	2"
		W	1"	2"
		X	1 1/4"	2"
		Y	1 1/2"	4"
		Z	2"	4"
R	BSPP Parallel	A	3/8 - 19	A M14 x 1.5
B	BSPT Taper Port	B	1/2 - 14	B M18 x 1.5
G	Metric ISO 6149-1	C	3/4 - 14	C M22 x 1.5
		D	1 - 11	D M27 x 2
		E	1 1/4 - 11	E M33 x 2
		F	1 1/2 - 11	F M42 x 2
		G	2 - 11	G M48 x 2

Example of Optional Port Accumulator

A **4** **N** **0231** **C** **3** **K** **T** **C** **U** **V**

Non-std. Port
SAE #8 Hyd. Port
NPT 3/4" Gas Port

Standard Ports Available (See Port Modifications Table if Using Other Than Standard Ports Shown Below)		
Bore Size	Standard Ports	Metric (BSPP) Ports
3"	SAE #12	3/4
4"	SAE #16	1
6"	SAE #16	1
7"	2" Code 62 Flange	2" ISO6162 Flange
9"	2" Code 62 Flange	2" ISO6162 Flange

Seal Compound (See Catalog for Temperature Settings)	
K	Buna Nitrile (Std)
E	Fluoroelastomer
D	EPR
H	Hydrogenated Nitrile
Q	Low Temp.
S	Special (to be specified)

* Safety fuse assembly not included.
Note: ASME and CRN units available upon request.

