

Standard Test Methods for Self-Compacting Concrete

CONTENTS

I. Test method for passability through spaces using U –shaped or Box-Shaped apparatus (Test method for self-compactability)	
1. Scope.....	50
2. Apparatus.....	50
3. Procedure.....	52
4. Calculation	53
5. Reports	53
II. Slump flow test method	
1. Scope.....	54
2. Apparatus.....	54
3. Sampling	55
4. Procedure.....	55
5. Results	56
6. Reports	56
III. Flow-through test method using funnels	
1. Scope.....	57
2. Apparatus.....	57
3. Sampling	58
4. Procedure.....	58
5. Test results	59
6. Calculation	59
7. Reports	60
IV. Test method for air content of fresh concrete using pressure (Air chamber pressure method)	
1. Scope.....	61
2. Apparatus for measuring air content.....	61
3. Sampling	63
4. Calibration of apparatus.....	63
4.1 Calibration of the container	63
4.2 Determination of initial pressure.....	63
4.3 Calibration of graduation for air quantity	64
5. Measurement of aggregate correction factor	65
6. Measurement of air content of concrete.....	65
7. Results	66
8. Reports	66
V. L -type flow test method	
1. Scope.....	68
2. Apparatus.....	68
3. Sampling	69
4. Procedure.....	69
5. Test results	70
6. Calculation	70
7. Reports	70
VI. Method of making concrete specimens for strength testing	
1. Scope.....	71
2. Concrete samples	71

2.1 Samples prepared in laboratories	71
2.2 Samples taken at other points.....	71
3. Number of specimens.	71
3.1 Specimens produced in laboratories.....	71
3.2 Specimens of concrete sampled at other points	72
4. Specimens for compression tests.....	72
4.1 Specimen size.....	72
4.2 Apparatus	72
4.3 Concrete placing	73
4.4 Top surface finishing of specimens.....	73
5. Specimens for flexure tests	75
5.1 Specimen size.....	75
5.2 Apparatus	75
5.3 Concrete placing.....	75
6. Specimens for tension tests.....	76
6.1 Specimen size.....	76
6.2 Apparatus	76
6.3 Concrete placing	76
7. Demolding and curing.....	76
8. Conveyance of specimens	77
9. Reports	77

Standard Test Methods for Self-Compacting Concrete

I. Test method for passability through spaces using U-shaped or Box-shaped apparatus (Test method for self-compactability)

1. Scope

This standard covers the test method for passability through spaces of self-compacting concrete with a maximum coarse aggregate size of 25 mm or less using a U-shaped or Box-shaped container.

2. Apparatus

2.1 The U-shaped or Box-shaped container shall be a sufficiently rigid container made of a material with smooth surfaces^[1] having shapes and dimensions as shown in Fig. 1 (a) or (b).

2.2 The U-shaped or Box-shaped container shall be of a structure having a flow obstacle of deformed bars vertically arranged like a fence^[2] as shown in Fig. 1 (a) and (b).

2.3 The U-shaped or Box-shaped container shall be of a structure in which Room A and Room B are separated by inserting a partition plate with an obstacle at its bottom and an sliding gate along the groove in the center^[3].

2.4 When the coarse aggregate content of concrete after passing through the obstacle is to be measured, the tester shall be equipped with a sampling gate^[4] on the room B side near the obstacle as shown in Fig. 1.

2.5 In addition, a container for charging (a 5-liter plastic jug, etc.), straightedge for leveling the top surface, measuring scale^[5], stopwatch^[6] and wet cloth shall be prepared.

Notes: (1) The internal surfaces of the container shall be smooth to minimize friction. Whereas any materials with smooth surfaces may be used, transparent materials are recommended to allow observation of the state of flowing.

(2) The obstacles include two types: Obstacle R1 with five D10 deformed bars and Obstacle R2 with three D13 deformed bars. Obstacle R2 is normally used. It is recommended that a suitable type be selected from these according to the shapes, dimensions and reinforcement conditions of the structure.

(3) If without any friction against the internal surfaces of the container, then the height of concrete in Room B in equilibrium is calculated to be 365 mm and 335 mm in the U-type and box-type, respectively. These correspond to the maximum fill heights of these testers. However, it is recommended that the maximum fill height of the tester be confirmed, e.g., by measuring the level of still water on the Room B side, as it slightly varies depending on the dimensional errors and thicknesses of the partition plate and sliding gate.

(4) The coarse aggregate content is not normally measured. However, where a more precise judgment of passability during filling by the concrete's own weight is required, the aggregate content after passing the obstacle shall be measured using samples taken from near the obstacle.

(5) The measuring scale to be used shall be of Type C, Class 1 or higher by JIS B 7516 and shall be measurable to 1 mm.

(6) The stopwatch shall be measurable to 1/10 sec

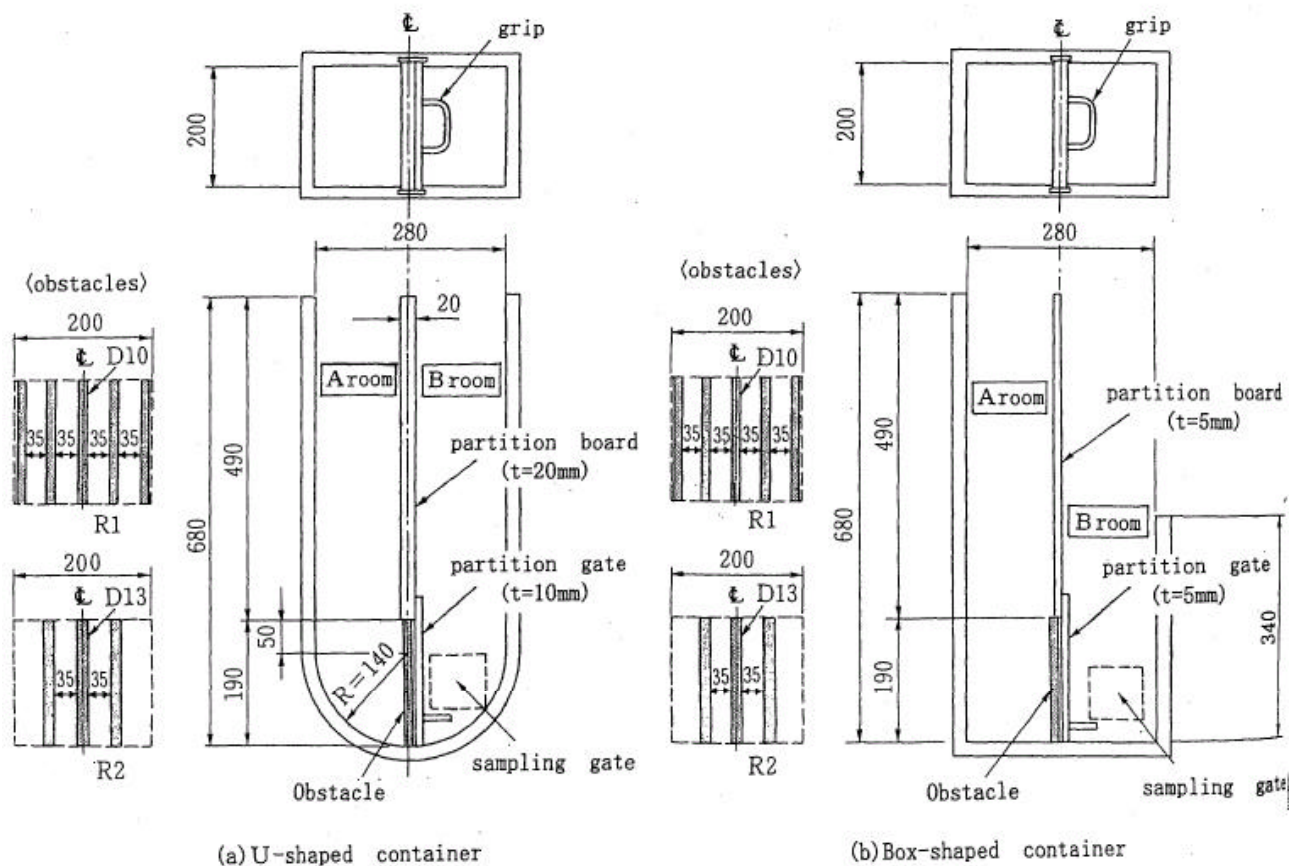

Fig. 1 Shapes and Dimensions of Apparatus for Self-Compaction Test

3. Procedure

- 3.1 Place the U-shaped or Box-shaped container vertically, with the top edge being horizontal.
- 3.2 Insert the sliding gate and partition plate with an obstacle into the U-shaped or Box-shaped container.
- 3.3 Wipe the internal surfaces of the tester, sliding gate, partition plate and obstacle with a wet cloth.
- 3.4 Place concrete in Room A from, e.g., a jug with the sliding gate closed. Concrete should be placed continuously to the top edge of Room A without rodding with a tamping rod or tapping.
- 3.5 Remove excess sample with a metal straightedge or trowel, level the sample with the top edge of the tester using, e.g., a straightedge, and leave to stand for 1 minute.
- 3.6 Open the sliding gate in a quick motion. Allow the concrete to flow through the obstacle into Room B, and leave to stand until the concrete stops.
- 3.7 Measure the height from the bottom to the top of the concrete in Room B to 1 mm with a measuring scale. Take this as the fill height, B_h (mm). Here the height is measured at three points, i.e., at the center of the tester width and both corners.
- 3.8 Measure the time from immediately after opening the sliding gate to the end of filling into Room B to 1/10 sec with a stopwatch. Take this as the filling time, B_{time} (sec).
- 3.9 When measuring the coarse aggregate content after passing the obstacle, take a sample from the sampling gate equipped near the obstacle on the Room B side. Measure the coarse aggregate content, m_c (g), in accordance with JIS A 1112 (Method of test for washing analysis of fresh concrete)^[7].

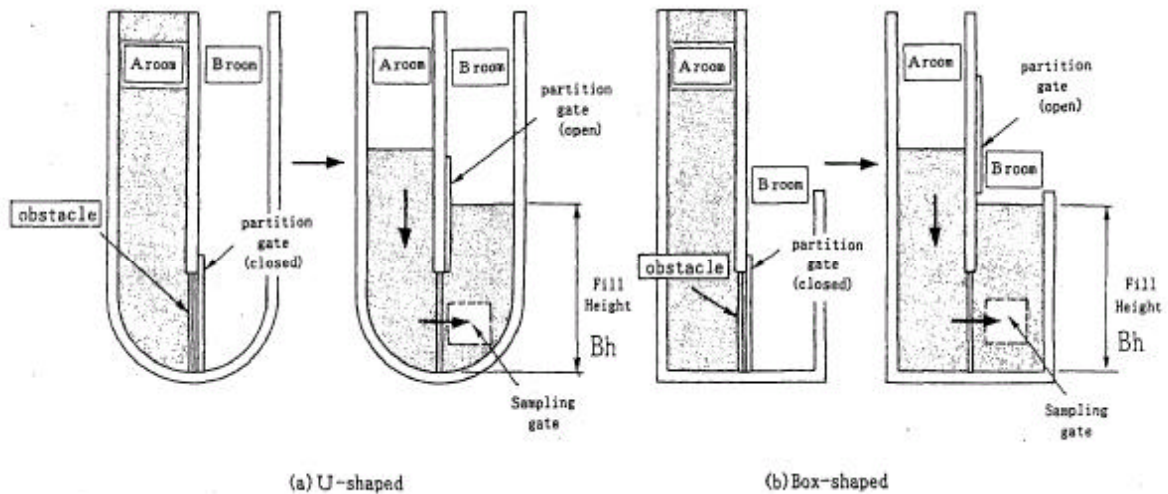

Fig.2 Measurement of Fill Height, B_h

Note: (7) While the test method is in accordance with JIS A 1112, the amount. of the sample shall be approximately 1 liter.

4. Calculation

4.1 Filling time--Express the measured filling time, B_{time} (sec), to the nearest 0.1 sec.

4.2 Fill height--Calculate the average fill height, B_h (mm), Of three measurements to an integer by rounding off at the first decimal place.

4.3 When measuring the coarse aggregate content after passing through the obstacle, calculate the coarse aggregate content, m_G (kg/m^3), in accordance with JIS A 1112 (Method of test for washing analysis of fresh concrete). Also calculate the mass ratio to the coarse aggregate content in the specified mixture proportions by the following equation:

$$\text{Coarse aggregate mass ratio} = m_G/m_{G0}$$

where m_G = coarse aggregate content after passing through an obstacle calculated in accordance with JIS A 1112 (kg/m^3)

m_{G0} = coarse aggregate content in the specified mixture proportions (kg/m^3)

5. Reports

The reports shall include necessary items from among the following:

- (1) Mixture proportions of concrete
- (2) Concrete temperature
- (3) Slump flow
- (4) Time to 500 mm flow
- (5) Type of container (U-shaped or Box-shaped)
- (6) Type of flow obstacle
- (7) Fill height, B_h
- (8) Filling time, B_{time}
- (9) Maximum fill height of the tester by calculation, $B_{h_{max}}$
- (10) Coarse aggregate content after passing through the obstacle, m_G , and coarse aggregate mass ratio, m_G/m_{G0}

II. Slump flow test method.

1. Scope

This standard covers the test method for slump flow of self-compacting concrete with a maximum coarse aggregate size of 40 mm or less.

2. Apparatus

2.1 A slump cone specified in JIS A 1101 (Method of test for slump of concrete) shall be used.

2.2 The plate^[1] shall be made of steel and sufficiently watertight and rigid. It shall be approximately 0.8 m by 0.8 m or larger in size and shall have a smooth surface. Handles, if required, shall be installed where they do not obstruct the slump flow measurement.

2.3 For measuring slump flow, calipers or a measuring scale^[2] and guides^[3] as shown in Fig. 1 shall be used.

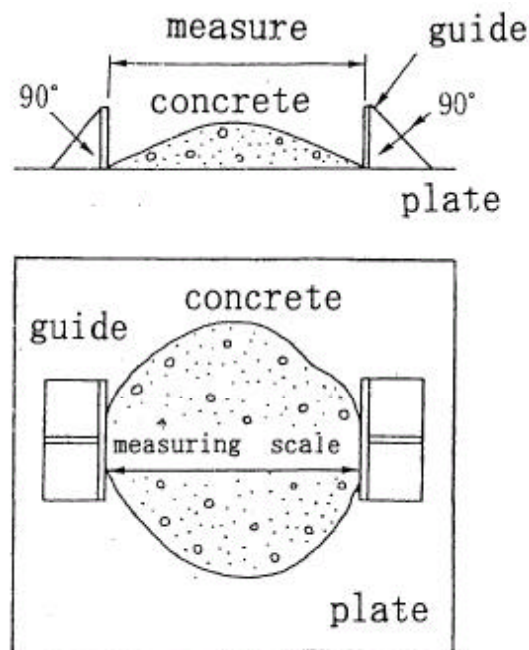

Fig. 1 slump flow measurement

Notes: (1) The thickness of the plate shall be at least 2.0 mm. For measuring the time to 500mm flow, drawing a circle 500mm in diameter is recommended.

(2) The measuring scale shall be Type C, Class 1 or higher in accordance with JIS B 7516 and shall be measurable to 1 mm.

(3) Pieces of cut L section steel, for instance, may be used as the guides. If accurate measurement is possible only with a measuring scale, guides may be excluded.

2.4 A container, such as a 12 liter bucket.

2.5 A stopwatch measurable to 1/10 sec.

3. Sampling

Samples shall be taken in accordance with JIS A 1115 (Method of sampling fresh concrete) or prepared in accordance with JIS A 1138 (Method of making test samples of concrete in the laboratory).

4. Procedure

4.1 Wipe the internal and external surfaces of the slump cone and plate with wet cloth. Place the slump cone on the plate, which is laid horizontally^[4].

4.2 Fill the sample in the cone either by Method A or Method B. The case where the actual

construction does not involve consolidation is referred to as Method A, and the case with vibratory consolidation is referred to as Method B. In Method A, concrete is filled in one continuous layer without rodding or vibrating^[5]. In Method B, concrete is filled in three layers of equal quantities. Level each layer with a tamping rod and then rod five strokes uniformly over the area.

Notes: (4) The horizontality shall be confirmed with a level.

(5) Prepare the sample in the receiving container and pour into the cone by evenly distributing the concrete over the area.

4.3 The time from the beginning to the end of filling concrete in the slump cone shall be within 2 minutes.

4.4 Level the top surface of concrete with the top rim of the slump cone, and immediately raise the cone vertically by a steady upward lift without interruption^[6]. When the movement of the concrete has stopped, measure the apparently maximum diameter and the diameter at right angles to it, and take the average of both diameters as the slump flow. The measurement shall be performed once.

Note: (6) The time to raise the slump cone to 300mm in height shall be 2 to 3 seconds.

4.5 When measuring the time to 500mm flow, measure the time from the beginning of the raising of the slump cone to the moment when the apparently maximum diameter reaches 500 mm with a stopwatch to the nearest 0.1sec.

4.6 When measuring the time to the end of the flow, measure the time from the beginning of the raising of the slump cone to the moment when the flow visually stops with a stopwatch to the nearest 0.1sec.

Remark: When measuring the slump, measure the vertical subsidence at the center of concrete, and take it as the slump. Measure the slump to the nearest 5mm.

5. Results

For the slump flow (mm), the two diameters at right angles to each other shall be measured to the nearest 1mm. The average shall be expressed to the nearest 5mm in accordance with JIS Z 8401.

Remark: If the spread of concrete is significantly deviated from a circle with a diameter variation for the slump flow being 50mm or more, another test shall be conducted taking a different sample from the same batch.

6. Reports

The reports shall include necessary items from among the following:

- (1) Date
- (2) Weather
- (3) Air temperature
- (4) Batch No.
- (5) Maximum coarse aggregate size
- (6) Concrete temperature
- (7) Slump flow
- (8) Time to 500mm flow
- (9) Time to the end of the flow
- (10) Slump
- (11) Visually detectable segregation

III. Flow-through test method using funnels

1. Scope

This standard covers the method of funnel testing for average flow-through speed, relative flow-through speed and flow-through indices of self-compacting concrete with a maximum coarse aggregate size of 25 mm or less.

2. Apparatus

2.1 Steel funnels with shapes and dimensions shown in Fig. 1 (a) or (b) shall be used^[1].

2.2 A funnel tester shall consist of a funnel and a stand to support it^[2].

2.3 The discharge orifice of the funnel shall be equipped with a watertight trap that is instantaneously openable, and the top edge/rim shall be smooth to allow leveling using a straightedge.

2.4 In addition to the funnel tester, a container for charging the funnel (e.g., a 5-liter plastic jug), receiving container (approximately 12 liters), straightedge for leveling the top surface, stopwatch^[3] and wet cloth shall be prepared.

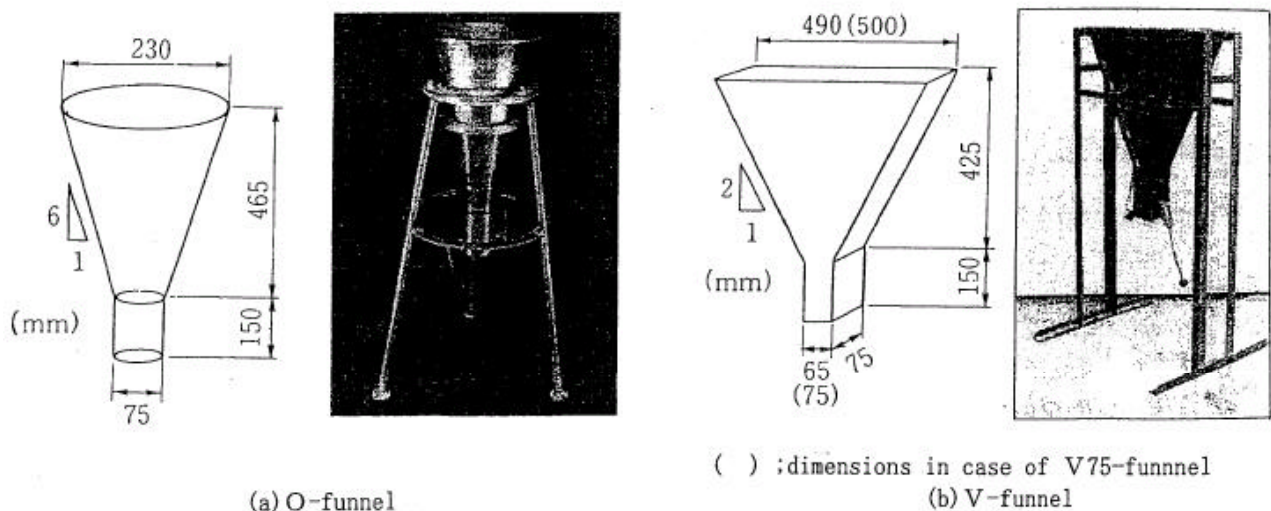

Fig. 1 Shapes and Dimensions of funnels
for Flow-through Test

Notes: (1) The internal surfaces of O-funnels and V-funnels shall be smoothly finished. Their capacity shall be 10 liters.

(2) It is desirable that the stand be adjustable to maintain horizontarity. A detachable stand is convenient for transportation.

(3) A stopwatch measurable to 1/10 sec shall be used.

3. Sampling

Samples shall be taken in accordance with JIS A 1115 (Method of sampling fresh concrete) or JIS A 1138 (Method of making test samples of concrete in the laboratory).

4. Procedure

4.1 Wash a funnel with water and set it vertically (with the top edge/rim being horizontal). Wipe with a tightly squeezed wet cloth to maintain the internal surfaces in a wet condition.

4.2 Place a receiving container under the orifice and close the trap^[4].

4.3 Gently pour a concrete sample from the charging container to the top edge/rim of the funnel.

4.4 Level the top surface of the concrete with the top edge/rim of the funnel using a straightedge^[5].

4.5 After having leveled the top surface, open the trap within 10 seconds and measure the time to the moment when all the concrete comes out of the funnel^[6] with a stopwatch^[7]. Take this as t_0 .

Along with this, observe and record the state of flowing (whether the concrete tended to clog up during flowing).

4.6 When determining the flow-through index, place a sample in the funnel as described in 4.1 to 4.4 above, leave to stand for 5 minutes^[8], and then measure the flow-through time. Take this as t_5 . Along with this, record the state of flowing during testing.

Notes: (4) Prior to charging the funnel with concrete, check if the orifice trap properly opens.

(5) This will adjust the sample quantity to exactly 10 liters.

(6) The high viscosity of concrete makes it difficult to identify the moment when all the concrete comes out of the funnel. Therefore the moment, seen from above, when the orifice opens is assumed to be the moment when the concrete has flowed through the funnel. Measure the flow-through time to an accuracy of 1/10 sec or higher.

(7) It is desirable that the flow-through time be measured twice or more within 5 minutes using different samples. In this case, wash the funnel with water before subsequent tests. Even if the quantity of the sample available for testing is limited, an average of two or three tests can significantly correct the scatter of sampling.

(8) It is known that the apparent flow-through time is elongated after a certain rest period. Concrete with a low segregation resistance can lead to a large difference in flow-through time between two tests. The degree of segregation can be judged by these tests to a certain extent.

5. Test results

5.1 Record the measured now-through time to the nearest 0.1 sec.

5.2 Record the state of flowing (whether the concrete tended to clog up during flowing) as well.

6. Calculation

6.1 When two or more tests were conducted, calculate the average to the nearest 0.1 sec, and take this as the flow-through time.

6.2 Calculate the average flow-through speed at the orifice by the following equation to 0.01 sec.

(a) O-funnel $m=2.26/t_0$

(b) V-funnel $V_m=2.05/t_0$

where V_m = average flow-through speed (m/s)

t_0 = flow-through time (s)

Remark: 2.26 and 2.05 are the values obtained by dividing a volume of 0.01 m³ by the cross-sectional area of respective orifices.

6.3 Calculate the relative flow-through speed by the following equation to the nearest 0.01 sec.

$$R_m=10/t_0$$

where R_m = relative flow-through speed

t_0 = now-through time (s)

6.4 Calculate the flow-through index by the following equation to the nearest 0.01 using the flow-through times measured under two test conditions:

$$S_f=(t_5 - t_0)/t_0$$

where S_f = flow-through index

t_0, t_5 = flow-through time (s)

if $t_5 < t_0$, then S_f is assumed to be zero.

7. Reports

The reports shall include necessary items from among the following:

- (1) Type of funnel
- (2) Mixture proportions of concrete
- (3) Concrete temperature
- (4) Flow-through time

- (5) Average flow-through speed
- (6) Relative flow-through speed
- (7) Flow-through index
- (8) State of flow/blockage

IV. Test method for air content of fresh concrete using pressure (Air chamber pressure method)

1. Scope

This standard covers the method of determining the air content of fresh self-compacting concrete by a pressure reduction in the air chamber^[1].

Note: (1) This test method is suitable for fresh concrete containing normal aggregate with a maximum size of 50 mm or less, but not suitable for fresh concrete containing porous aggregate, such as artificial lightweight aggregate, for which the aggregate correction index cannot be accurately determined.

Remarks: (1) The principle of this test is based on Boyle's law.

(2) The referenced standards for this test method are as follows:

JIS A 1115 (Method of sampling fresh concrete)

JIS A 1116 (Method of test for unit weight and air content (gravimetric) of fresh concrete)

JIS A 1138 (Method of making test samples of concrete in the laboratory)

(3) Units and values expressed in { } are those in conventional units, given for reference.

2. Apparatus for measuring air content

The apparatus for measuring air content shall be as follows:

2.1 The apparatus for measuring air content shall be the type designed for use with water poured in the space between the fresh concrete and the cover as shown in Fig. 1.

Remark: The type designed for use without water may also be used.

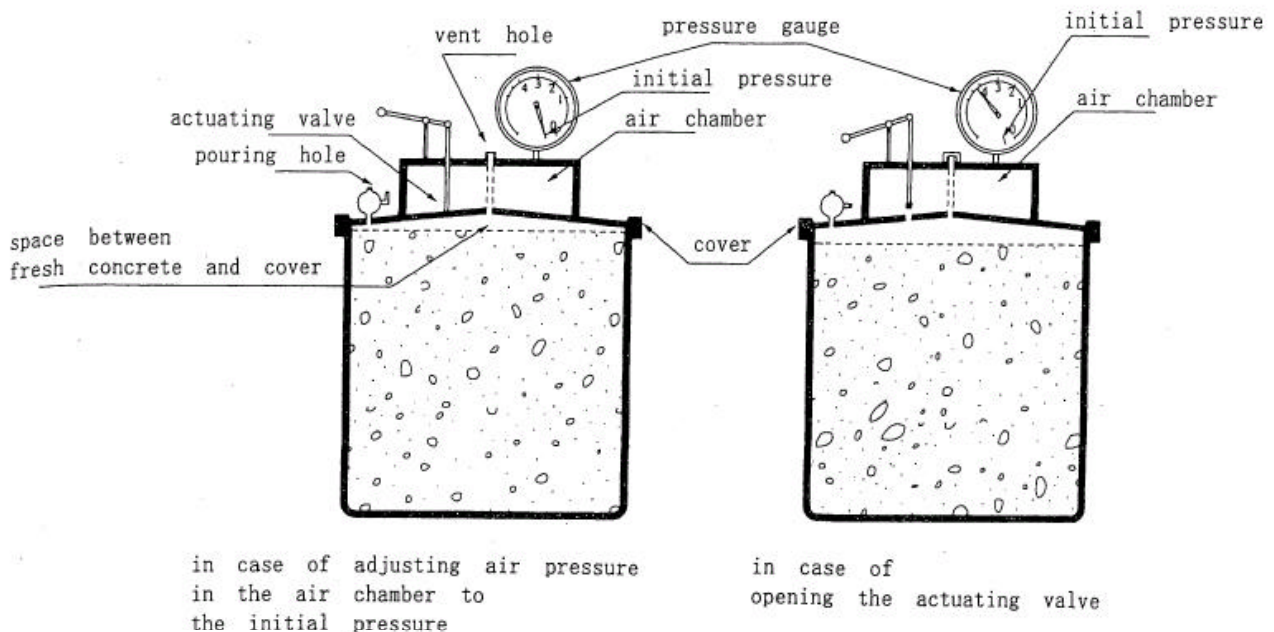

Fig.1 Air chamber

2.2 The container shall be a flanged cylindrical container made of a material not easily affected by cement paste and shall be watertight and sufficiently rigid. The diameter of the container shall be nearly equal to its depth, with the capacity being approximately 7 liters. In addition, the internal surfaces of the container and the top surface of the flange shall be smoothly machined.

2.3 The cover shall be flanged and made of a material similar to the container. It shall also be

watertight, sufficiently rigid and equipped with a water charging port and vent hole. The internal surface of the cover and the surface of the flange facing the container shall be smoothly machined.

Remark: Apparatuses designed to be used for tests without watering shall be so designed to allow a syringe or other tools to be inserted through the vent hole.

2.4 The cover shall be equipped with an air chamber on its top with a capacity of approximately 5% of that of the container. The air chamber shall have a pressure-regulating valve connected to a hand pump and pressure gage. Also, an actuating valve shall be provided, with which the high pressure in the air chamber can be ejected into the container after the cover and container have been assembled. The actuating valve shall be so designed as to allow no water to penetrate into the air chamber. When the cover and container are assembled, the apparatus shall be so designed to allow no leakage of air or water under a pressure of 100kPa (1kgf/cm²).

2.5 The pressure gage shall be of a capacity of 100kPa (1kgf/cm²) and sensitivity of approximately 1kPa (0.01 kgf/cm²). Its dial plate shall be not less than 90 mm in diameter and be graduated to represent the pressure corresponding to the percentages of the air quantity in the container (see 4.3). The dial shall also clearly indicate the initial pressure (see 4.2).

2.6 For calibration of the unit, a tool shall be prepared for easy removal of a required amount of water from the apparatus.

3. Sampling

Samples shall be taken in accordance with JIS A 1115 or made in accordance with JIS A 1138.

4. Calibration of apparatus

4.1 Calibration of the container

Fill the container with water and weigh the mass of the water. To fill water in the container, thinly apply cup grease to the flange of the container and place a polished glass plate on the flange. Fill the container with water while moving the glass plate along the flange carefully so as to allow no air bubbles to remain. Weigh the mass with a scale having a reciprocal sensitivity higher than 0.1% of the total mass of the container and water.

4.2 Determination of initial pressure

The initial pressure shall be determined as follows:

(1) Fill the container with water and attach the cover^[2] gently to the container with the vent hole open. After attaching the cover, pour water until the air enclosed between the cover and the water level is discharged.

Note: (2) The calibrating tool (see 2.6) shall be fixed at this stage, if so designed.

Remark: Where no additional water is used, the water level in the container shall be accurately flush with the top rim of the container.

(2) Close all the valves, and operate the hand pump to make the pressure in the air chamber slightly exceed the initial pressure. Approximately 5 seconds later, gradually open the regulating valve until the pointer of the pressure gage points accurately to the initial pressure mark.

(3) Fully open the actuating valve to equalize the air pressures of the air chamber and the top of the container, and take the pressure gage reading. Check if the reading exactly agrees with the graduation for 0% air. If they do not agree, check for any leakage of air or water or any other defect, and repeat the calibration procedure. When the pointer points to the same position deviating from the zero point in the calibration procedure repeated several times, slide the position of the initial pressure mark so that the pointer points to it. Repeat the calibration procedure to confirm that the new position for the initial pressure mark is correct.

4.3 Calibration of graduation for air quantity

The graduation for air quantity shall be calibrated as follows:

(1) Follow the same procedure as 4.2 (1), and then proceed to the following:

(a) Transfer an adequate quantity of water from the container to a graduated cylinder using the tool described in 2.6 and express the quantity in percentage by volume of the capacity of the container.

(b) After equalizing the air pressure in the container with atmospheric pressure, close up the apparatus and increase the air pressure in the air chamber to the initial pressure.

(c) Open the actuating valve to introduce the high-pressure air into the container.

(d) Take an air-quantity reading after the pointer of the pressure gage has been stabilized.

(2) Transfer water from the container to the graduated cylinder again as instructed in (1), and express the total quantity of the water collected in percentage by volume of the capacity of the container. Take a reading of the air quantity similarly to (1).

(3) Repeat the above operations several times and compare the percentages of the collected water with the graduation marks for air quantity. When these values agree, the graduation marks are correct. When they disagree, make a diagram showing their relationship. Use this diagram for calibration of the air quantity graduation.

Remark: Whenever reading a pressure gage, take readings after tapping it lightly with your finger.

5. Measurement of aggregate correction factor

The aggregate correction factor shall be measured as follows:

(1) Calculate the mass of fine and coarse aggregates in a concrete sample with a volume V , of which the air content is to be determined, by the following equations:

(Eq.)

where w_f = mass of fine aggregate in sample concrete with a volume of V (kg)

V = volume of sample concrete (equal to the capacity of container) (liter)

B = volume of as-mixed concrete per batch (liter)

W_f = mass of fine aggregate used per batch (kg)

w_c = mass of coarse aggregate in sample concrete with a volume of V (kg)

W_c = mass of coarse aggregate used per batch (kg)

(2) Collect representative samples of fine and coarse aggregates, w_f and w_c in mass, respectively. Immerse fine and coarse aggregates separately in water^[3] to make the moisture conditions of the sample aggregate particles equivalent to that of the aggregate particles in the sample concrete. Place aggregate in the container containing water to approximately one third of its capacity. To place aggregate, place a scoopful of fine aggregate followed by two scoopfuls of coarse aggregate so that all aggregate particles can be immersed in water. Minimize air entrapped in water when placing aggregate. Emerging air bubbles must be removed promptly. Tap the side of the container with a mallet to release air. Also, rod approximately 10 strokes with a tamping rod to a depth of approximately 25 mm each time fine aggregate is added.

Note: (3) An immersion time of approximately 5 minutes is recommended.

(3) After having placed all the aggregate in the container, remove all air bubbles on the surface of water, wipe the flanges of the cover and container and fasten the cover to the container with a rubber gasket in between. Follow the procedure described in 6. (2) and take an air quantity reading by the pressure gage^[4]. This is taken as the aggregate correction factor, G .

Note: (4) This reading shall be corrected in accordance with 4.3 (3) where required.

6. Measurement of air content of concrete

Measure the air content of concrete as follows:

(1) Place the sample in the container by either Method A or Method B. In Method A, the sample is placed in one layer until it slightly overflows the container without rodding or vibration^[5]. In Method B, the sample is filled in three layers of nearly equal depths, each layer being rodded, distributing approximately ten strokes uniformly distributed over the area, and the side of the

container being tapped with a mallet approximately five times. In both methods, the sample is leveled with the top rim, with the excess being scraped off with a straightedge.

Note: (5) The sample shall be prepared in the receiving container and poured uniformly into the container.

(2) Thoroughly wipe the top surface of the container flange and bottom surface of the cover flange and attach the cover gently to the container, with the cover being vented. Fasten the cover to allow no air leakage and pour water in accordance with 4.2 (1). Adjust the air pressure in the air chamber to the initial pressure in accordance with 4.2 (2). Approximately 5 seconds later, fully open the actuating valve. Tap the side of the container with a mallet to distribute the pressure within the container. Fully open the actuating valve again and take an air quantity reading to the nearest 0.1% by the pressure gage^[4] after the pointer is stabilized. Take the reading as the apparent air content of the concrete (A_1).

7. Results

Calculate the air content of concrete (A) by the following equation:

$$A = A_1 - G$$

where A = air content of concrete (%)

A_1 = apparent air content of concrete (%)

G = aggregate correction factor^[6]

Note: (6) An aggregate correction factor of 0.1% or less may be omitted.

8. Reports

The reports shall include the following:

- (1) Air content
- (2) Mixture proportions of concrete
- (3) Type of chemical admixtures
- (4) Slump flow
- (5) Concrete temperature

V. L-type flow test method

1. Scope

This standard covers the L-type flow test method without obstacles for self-compacting concrete with a maximum aggregate size of 25 mm or less.

2. Apparatus

2.1 The standard L-type flow tester shall be a device made of steel having shapes and dimensions as shown in Fig. 1^[1].

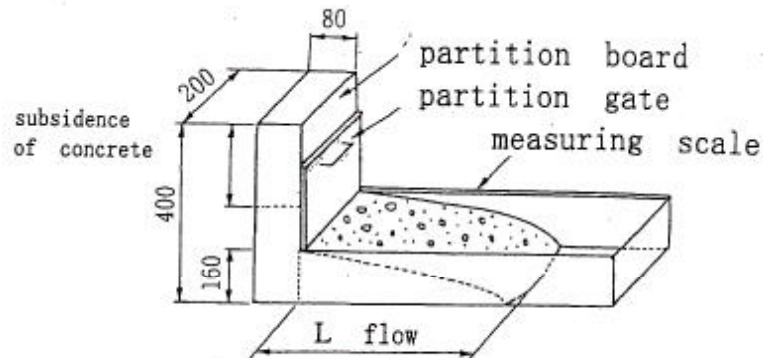

Fig. 1 Shapes and Dimension of L-type flow tester

2.2 An L-type flow tester shall have a sliding gate to prevent the flow of concrete at the time of charging.

2.3 The sliding gate shall be made of a material that is not deformed or damaged during concrete charging or when raised.

2.4 A measuring scale fixed on the edge of the channel will facilitate the measuring of the time to reach the maximum or any other L-flow distance^[2].

2.5 In addition to the L-type flow tester, a container for charging the tester (e.g., a 5-liter plastic jug), straightedge for leveling the top surface, stopwatch^[3], measuring scale and wet cloth shall be prepared.

Notes: (1) In the case where the relationship between the rheological properties of the concrete and various values obtained from this L-type flow tester are evident beforehand, a tester of a size different from Fig. 1 may be used.

(2) The measuring scale to be used shall be of Type C Class 1 precision or higher in accordance with JIS B 7516, measurable to 1 mm. A measuring scale with adhesive tape on the back side is convenient.

(3) The stopwatch shall be measurable to 1/10 sec.

3. Sampling

Samples shall be taken in accordance with JIS A 1115 (Method of sampling fresh concrete) or made in accordance with JIS A 1138 method of making test samples of concrete in the laboratory).

4. Procedure

4.1 Place the L-type flow tester on a horizontal plane^[4] and wipe the internal surfaces of the tester with a wet cloth.

4.2 Attach the sliding gate to the L-type flow tester and pour the sample using the charging container in one layer without applying rodding or vibration.

4.3 Level the top surface of the concrete filled in the tester with the top edge using a straightedge.

4.4 When the top surface has been leveled, immediately raise the sliding gate. An L-flow refers to

the distance between the inside of the sliding gate and the tip of concrete.

4.5 Measure the time to reach an arbitrary L-flow^[5] with a stopwatch.

4.6 The L-flow when the motion of concrete stops is referred to as the maximum L-flow^[6]. Also, measure the subsidence of concrete from the initial level by reading the length from the top edge of the tester to the highest point of the concrete with a measuring scale.

Notes: (4) Confirm the horizontality using a level.

(5) Select a point along the channel to which the flow time can be measured with a stopwatch, judging from the target L-flow. Measure the time from the moment the sliding gate is raised to the moment the tip of concrete reaches the point. The standard distance to measure the L-flow time is 500 mm.

(6) In L-type flow tests, concrete near the side walls of the channel can exhibit a slightly lower flow speed than concrete in the center, due to friction with the side walls.

5. Test results

5.1 Measure the maximum L-flow and subsidence to the nearest 1 mm and round off to the nearest 5 mm in accordance with JIS Z 8401.

5.2 Measure the time to an L-flow distance to the first decimal place.

6. Calculation

The flow speed of concrete shall be calculated by the following equation and rounded off to an integer:

$$V_i = L_i / t_i$$

where V_i = average flow Speed of concrete to an L-flow of i mm (mm/s)

L_i = L-flow distance to which L-flow time is measured (mm)

T_i = time to reach an L-flow distance of i mm (s)

7. Reports

The reports shall include necessary items from among the following:

(1) Mixture proportions of concrete

(2) Concrete temperature

(3) Minimum L-flow

(4) Flow speed (time)

1) Time to reach an arbitrary L-flow distance during flowing, as well as the L-flow distance

2) Time to the end of the flow

(5) Subsidence

(6) Visually detectable segregation

VI. Method of making concrete specimens for strength testing

1. Scope

This standard covers the methods of producing self-compacting concrete specimens for strength testing. In regard to concrete with high fluidity that is placed with vibratory consolidation, specimens shall be produced in accordance with JIS A 1132 (Method of making and curing concrete specimens). The term "strength testing" refers to tests for compressive strength (JIS A 1108), tensile strength (JIS A 1113) and flexural strength (JIS A 1106). This standard applies to self-compacting concrete with a maximum coarse aggregate size of 40 mm or less.

Remark: The referenced standards for these methods are as follows:

JIS A 1106 (Method of test for flexural strength of concrete)

JIS A 1108 (Method of test for compressive strength of concrete)

JIS A 1113 (Method of test for splitting tensile strength of concrete)

JIS A 1115 (Method of sampling fresh concrete)

JIS A 1138 (Method of making test sample of concrete in the laboratory)

2. Concrete samples

2.1 Samples prepared in laboratories

When preparing concrete samples in laboratories, the method shall be in accordance with JIS A 1138.

2.2 Samples taken at other points

When sampling concrete from mixers, hoppers, agitator trucks or placed concrete, the method shall be in accordance with JIS A 1115.

3. Number of specimens

3.1 Specimens produced in laboratories

When producing specimens from samples mixed in accordance with 2.1 above, the number of specimens required for identical conditions^[1] shall be at least three. These three or more specimens shall as a rule be produced from two or more concrete batches.

Note: (1) The conditions shall include the age of specimens.

3.2 Specimens of concrete sampled at other points

When producing specimens from samples taken in accordance with 2.2 above, the number of specimens shall be established according to the purpose of the tests.

4. Specimens for compression tests

4.1 Specimen size

Compression specimens shall be cylinders with a height being two times the diameter. The diameter shall be not less than three times the maximum size of coarse aggregate and not less than 100 mm.

Reference: The standard diameters of specimens are 100, 125 and 150 mm. Self-compacting concrete shall not be sifted with a sieve to reduce the specimen size as practiced for normal concrete.

4.2 Apparatus

The apparatus shall include the following:

- (1) The molds shall be rigid metal cylinders consisting of a side wall and bottom plate and shall be assembled by a suitable method.
- (2) The molds shall be free from deformation or water leakage during molding.
- (3) The dimensional errors shall be within 1/200 and 1/100 in diameter and height, respectively. The flatness of the bottom plate^[2] of the molds shall be within 0.02 mm. When the molds are assembled, the axis of the side wall (cylinder) shall be nearly perpendicular to the bottom plate.

Note: (2) The flatness referred to here is the distance between two parallel planes, one including the highest point and the other including the lowest point of the plate.

Reference: Lightweight molds that satisfy the requirements (2) and (3) above may be used. However, the specimens shall not be capped with paste when such molds are used.

(4) Molds shall be assembled with oily clay or hard grease thinly applied to joints. Prior to placing concrete, mineral oil shall be applied to the internal surfaces of molds.

(5) The capping plate shall be a polished glass plate at least 6 mm thick and at least 25 mm greater in diameter than the mold.

4.3 Concrete placing

(1) Concrete shall be placed either by Method A or Method B. In Method A, concrete is gently placed in one layer to the top rim to minimize entrapped air. In Method B, concrete is placed in two layers of nearly equal depths, and each layer is rodded with a tamping rod, distributing five

strokes uniformly over the area. Method B shall be applicable only to cylindrical specimens 100 mm in diameter and 200 mm in height. Where the smoothness of surfaces is of importance, concrete shall be spaded along the mold or tapped on the side wall of the mold with a mallet^[3].

Note: (3) The tapping shall be 5 to 8 strokes. Lightweight molds shall be tapped lightly across dedicated frames.

(2) Place concrete to the top rim of the molds. Concrete shall be slightly underfilled^[4] when the specimens are to be capped with paste. Concrete shall be filled to the top rim for treatment by polishing or sulfur capping.

Note: (4) The standard recess depth shall be approximately 3 mm.

4.4 Top surface finishing of specimens

The top surface of specimens shall be finished as follows:

(1) The top surface of specimens shall be finished to a plane as perpendicular as possible to the axis of the specimen. The flatness of the finished surface^[2] shall be within 0.05 mm. When capping the specimens, the cap thickness shall be minimized.

(2) When capping the specimens before demolding, wash the top surface of the concrete with water to expose the sound surface at an appropriate time after filling concrete^[5]. Wipe off water and place a conical mound of cement paste^[6]. Form the cap by uniformly pressing the mound with the capping plate until the plate contacts the rim of the mold. The thickness of the cap shall be minimized, and a sheet of thin and strong paper shall be inserted below the plate to prevent the plate from being set with the paste. When capping with cement paste containing aluminum powder^[7], it shall be confirmed that this does not adversely affect the compressive strength, and a weight shall be placed to prevent floating of the capping plate.

Notes: (5) This shall be 6 to 24 hours in the case of self-compacting concrete.

(6) The water-cement ratio of cement paste shall be 27% to 30%. The cement paste shall be mixed approximately 2 hours before use, and retempered without adding water just prior to using.

(7) It is recommended that the paste containing the aluminum powder and mineral admixtures be proportioned to provide a free expansion of 10% to 12%, with the water-cement ratio being 27% to 30%. In this case, the cement paste can be used without a waiting time after mixing.

(3) When capping demolded specimens, a mixture of sulfur and mineral powder^[8], hard gypsum or a mixture of portland cement and hard gypsum shall be used. In this case, a suitable device shall be used to make the capped surface as perpendicular as possible to the axis of the specimen. Specimens shall be covered with a wet cloth to protect them from drying until the capping material hardens.

Notes: (8) Materials to be used as the mineral powder shall include those that are not chemically reactive when heated with sulfur, such as refractory powder, fly ash and stone powder. A ratio of sulfur and mineral powder of 3:1 to 6:1 by mass is recommended.

(9) A higher temperature can make it gummy and reduce the strength.

Remarks: 1. When capping with sulfur, a mixture of sulfur and mineral powder shall be used. Heat the mixture to 130 to 145 °C^[9], spread over a polished steel plate and press the specimen evenly. When sulfur is used for capping, the specimens shall be left to stand for at least 2 hours before testing.

2. Where the compressive strength of concrete is expected to be below 30.0 N/mm², the specimens may be capped with hard gypsum or a mixture of hard gypsum and portland cement. In this case, it shall be confirmed beforehand that the compressive strength of the same material as that used for capping, with the same proportions, exceeds 30.0 N/mm² by the tests on broken pieces of beams

40 by 40 by 160 mm in size. For capping, add a required amount of water to hard gypsum or a mixture of hard gypsum and portland cement and thoroughly mix until uniform. Spread the mixture over a capping plate and press the specimen evenly.

Reference: Where the compressive strength of concrete is expected to exceed 60 N/mm², it is recommended that the specimens be finished by paste capping and polishing. When capping with sulfur, care should be exercised, as sulfur caps can lead to strength losses of specimens in the high strength range.

(4) Where no caps are to be provided on specimens, the ends of specimens shall be finished by polishing.

5. Specimens for flexure tests

5.1 Specimen size

Flexure specimens shall be beams whose cross section is a square with a side length not less than three times the maximum coarse aggregate size and not less than 100 mm. The beam length shall be at least 80 cm longer than three times the side length of the cross-section.

Reference: The standard cross-sectional size of flexure specimens is 100 by 100 mm or 150 by 150 mm. Self-compacting concrete shall not be sifted with a sieve to reduce the size of specimens as practiced for normal concrete.

5.2 Apparatus

The apparatus shall include the following:

- (1) The molds shall consist of a metal bottom, sides and ends, which are assembled with suitable fasteners.
- (2) The molds shall be free from deformation and water leakage during the production of specimens.
- (3) The dimensional errors of molds shall not exceed 1/100 of the depth or breadth. The flatness of the sides and ends^[2] shall be within 0.05 mm. The sides, bottom and ends shall be at right angles to each other when assembled, and true and free of warpage.
- (4) Molds shall be assembled with oily clay or hard grease being thinly applied to joints. Prior to placing concrete, mineral oil shall be applied to the internal surfaces of the molds.

5.3 Concrete placing

- (1) Concrete shall be placed into molds with the longitudinal axis being horizontal. Concrete shall be poured gently in one layer up to the top edge, minimizing entrapped air. Where the smoothness of the formed surfaces is important, the concrete shall be spaded along the molds or lightly tapped on the sides of the molds with a mallet^[3].
- (2) Molds shall be maintained horizontal during and after placing until concrete hardens.
- (3) After the concrete has been placed, the excess concrete shall be scraped off and the top surface shall be finished with a trowel^[10].

Note: (10) Since self-compacting concrete causes little bleeding, it is recommended that the top surfaces be finished with a trowel.

6. Specimens for tension tests

6.1 Specimen size

Tension specimens shall be cylindrical, with the diameter being not less than four times the maximum coarse aggregate size and not less than 150 mm. The length of specimens^[11] shall be not less than the diameter and not more than two times the diameter.

Note: (11) It is recommended that the length of specimens be determined in consideration of the length of the loading plate of the tester. When the diameter is 150 mm, a length of approximately 200mm is advisable.

6.2 Apparatus

The apparatus for producing tension specimens shall be in accordance with 4.2.

6.3 Concrete placing

- (1) Concrete shall be placed similarly to 4.3 (1).
- (2) The molds shall be maintained horizontal during and after placing until the concrete hardens.
- (3) The top surfaces shall be finished by lightly leveling using a trowel after placing.

7. Demolding and curing

Concrete shall be demolded and cured as follows:

- (1) Concrete placed in the molds shall be demolded after it has hardened. The time for demolding shall as a rule be 24 to 48 hours after the end of placing. Until demolding, the molds shall be covered with a glass plate to prevent water evaporation.
- (2) The standard curing temperature shall be 20 ± 3 °C [12]. After demolding, the specimens shall be cured in a moist condition until strength testing. Placing specimens in water, wet sand or saturated moist air^[13] is recommended to maintain them in a moist condition.

Note: (12) When specimens are cured at a temperature out of this range, the temperature during production and curing shall be recorded.

(13) When water-cured, specimens shall not be exposed to running water. When curing specimens in wet sand or wet cloth, care shall be exercised as the evaporation of water reduces the temperature around the specimens.

8. Conveyance of specimens

The time for conveying specimens produced on site to the laboratory for curing as specified in 7.

- (2) shall be as soon as possible after the specimens become conveyable without being damaged.

9. Reports

The reports shall include the following:

- (1) Purpose of tests
- (2) Specimen No.
- (3) Type and qualities of materials
- (4) Mixture proportions of concrete
- (5) Date and time of specimen production and age, date and time of strength tests
- (6) Method of preparing or taking samples
- (7) Shapes and dimensions of specimens and method of placing
- (8) Type of capping or method of end finishing
- (9) Temperature of freshly mixed concrete
- (10) Air temperature and relative humidity when specimens are produced
- (11) Curing method