

NISSAN

# e-NV200 (VAN/COMBI & LUDOSPACE) (MEO)

05 - '14 →

## RPS 30

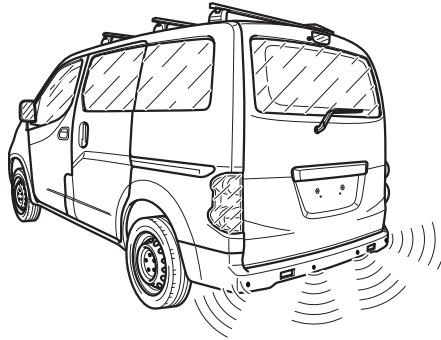

REAR PARK SYSTEM • INSTALLATION MANUAL  
RÜCKFAHRSENSOR • EINBAUANLEITUNG  
DÉTECTEUR DE REcul • NOTICE D'INSTALLATION  
ACHTERUITRIJSENSOR • HANDLEIDING VOOR DE INSTALLATIE  
SENSOR DE MARCHA ATRÁS • MANUAL DE INSTALACION  
BACKSENSOR • INSTALLATIONS MANUAL  
SENSOR DE MARCHA-ATRÁS • MANUAL DE INSTALAÇÃO  
SENSORE DI RETROMARCIA • MANUALE D'INSTALLAZIONE  
РУКОВОДСТВО ПО УСТАНОВКЕ  
ДАТЧИК ЗА ЗАДЕН ХОД • ИНСТРУКЦИЯ ЗА МОНТАЖ  
SENZOR ZA VOŽNJU UNATRAG • UPUTSTVO ZA INSTALIRANJE  
BAKKESENSOR • INSTALLERINGS MANUAL  
PERUUTUSANTURI • ASENNUSOPAS  
ΑΙΣΘΗΤΗΡΑΣ ΟΠΙΣΘΕΝ • ΕΓΧΕΙΡΙΔΙΟ ΕΓΚΑΤΑΣΤΑΣΗΣ  
HÁTRAMENET ÉRZÉKELŐ • FELSZERELÉSI KÉZIKÖNYV  
VIDVÖRUNARBÖKKUNARKERFI • UPPSETNINGARHANDBÓK  
PARKERINGSSYSTEM • INSTALLASJONSHANDBOK  
CZUJNIK COFANIA • INSTRUKCJA INSTALACJI  
SENZOR DE MARŞARIER • MANUAL DE INSTALARE  
SENZOR SPÄTNÉHO CHODU • NÁVOD NA INŠTALÁCIU  
TIPALO VZVRATNE PRESTAVE • PRIROČNIK ZA MONTAŽO  
SENZOR ZPĚTNÉHO CHODU • NÁVOD K INSTALACI  
ARKA PARK SİSTEMİ • KURULUM EL KİTABI  
ЗАДНІЙ ПАРКТРОНІК • ІНСТРУКЦІЯ З МОНТАЖУ

מדריך התקנה • מערכת נסיעה לאחור  
كُتِبَ التركيب • جهاز استشعار السير إلى الوراء

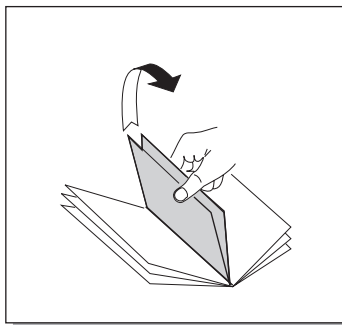

- Remove the central part containing the templates.
- Den zentralen Teil mit den Schablonen entfernen.
- Enlever la partie centrale contenant les gabarits.
- Verwijder het middelste deel met de boormallen.
- Quitar la parte central que contiene las plantillas.
- Ta bort mittdelen med bormallarna.
- Retirar a parte central que contém as bitolas.
- Rimuovere la parte centrale contenente le dime.
- Удалите центральную часть, в которой содержатся кондукторы.
- Демонтируйте централната част, съдържаща шаблоните.
- Maknite središnji dio sa šablonama.
- Fjern midterdelen med skabelonerne.
- Poista keskiosa, joka sisältää mallit.
- Αφαιρέστε το κεντρικό μέρος που εμπεριέχει τα ιχνάρια.
- Távolítsa el a középso, a sablonokat tartalmazó részt.
- Fjarlægðu miðhlutann sem inniheldur sniðmátin.
- Fjern den sentrale delen som inneheld malane.
- Wyjść część centralną zawierającą schematy.
- Scoateți partea centrală conținând șabloanele.
- Odložte strednú časť so šablónami.
- Odstranite osrednji del, ki vsebuje šablono.
- Odložte střední část se šablonami.
- Şablonları barındıran merkez kısmı çıkarınız.
- Зняти центральну частину, що містить опорні пластини.

• הסר את החלק המרכזי המכיל את התבניות

• أزل القسم الأوسط الذي يحتوي على القوالب

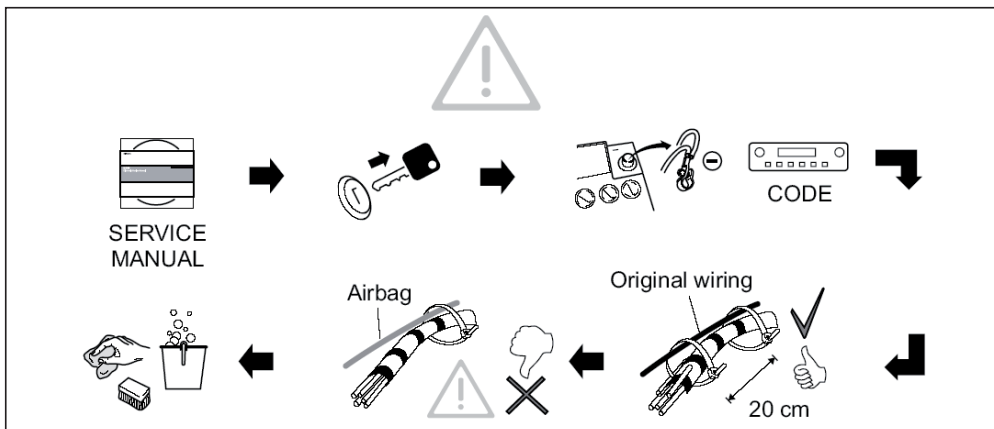

1

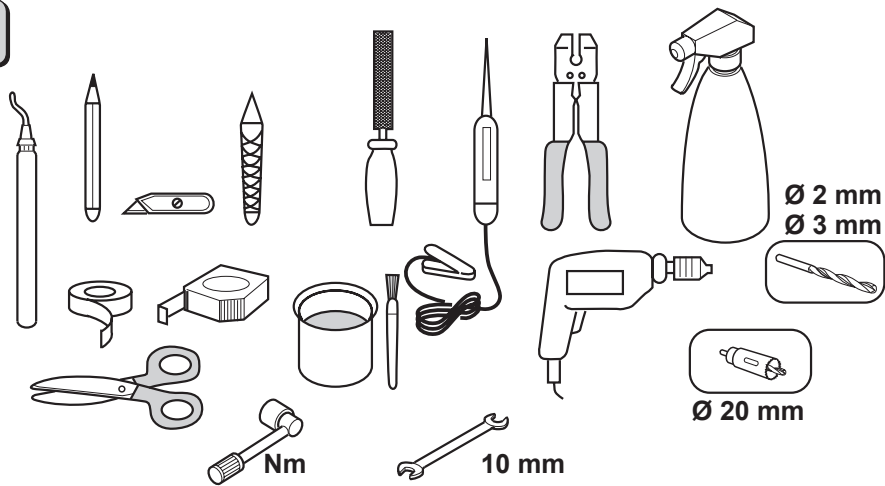

2

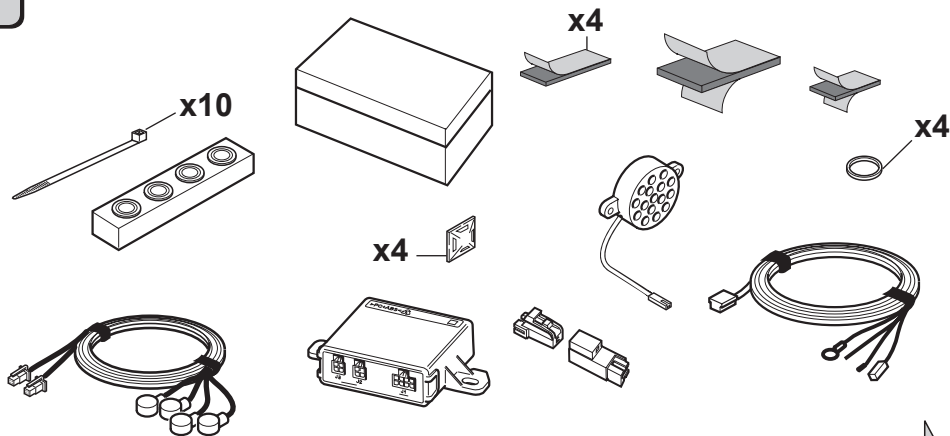

3

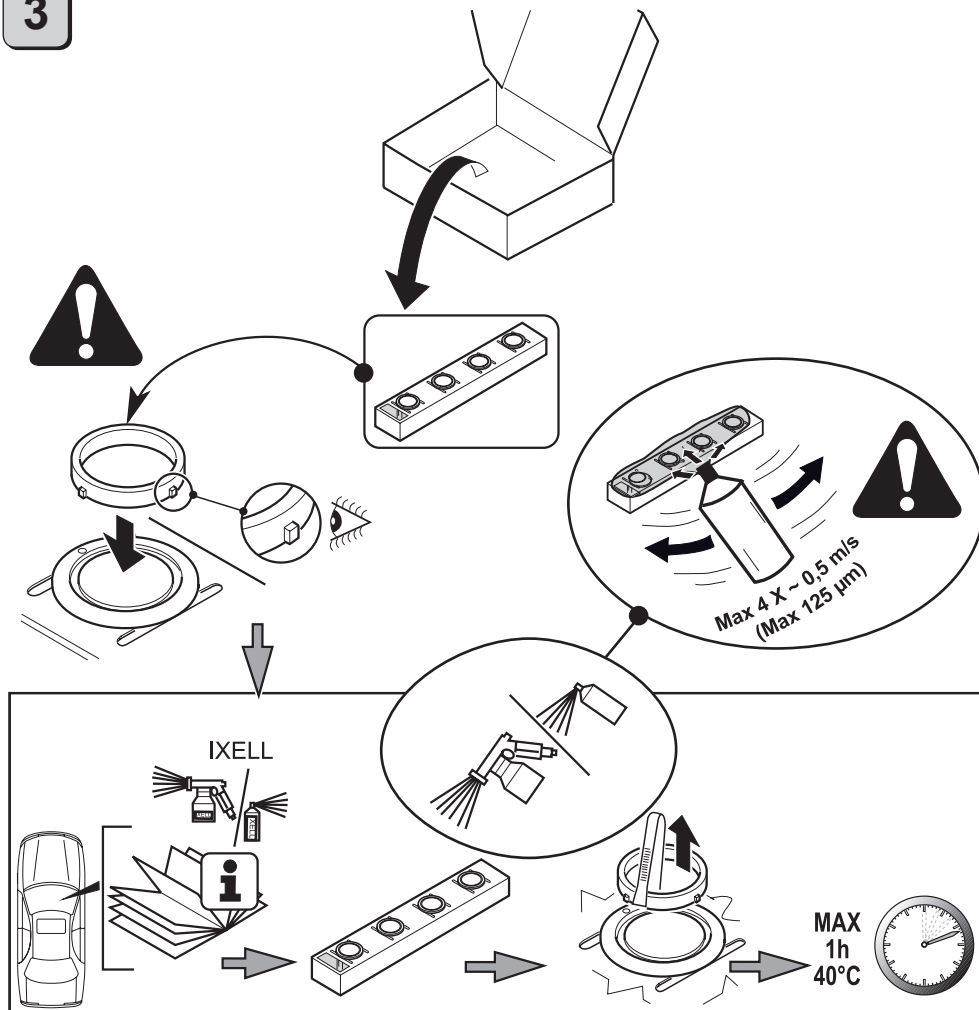

Block diagram - Blockdiagramm - Schema fonctionnel - Blokkendiagram  
 Esquema bloques - Blockschema - Esquema por blocos - Schema a blocchi  
 Блок-схема - Блок-схема - Blok shema - Blokkdiagram - Pylväskaavio  
 Σχέδιο με φραγές - Blokkvázlat - Reitamynd - Blokkdiagram - Schemat blokowy  
 Schema blocări - Bloková schéma - Shema sestavnih delov - Blokové schéma  
 Blok diyagram - Блок-схема - תרשים מלבני - ترسیمه وفقاً لكتل مجزأة

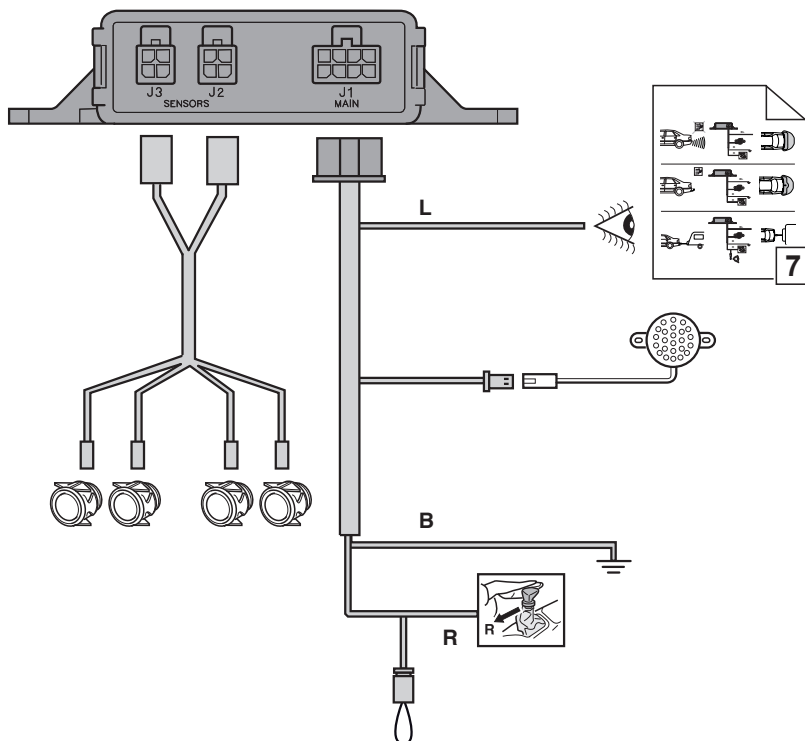

- B** = Black • Schwarz • Noir • Zwart • Negro • Svart • Preto • Nero • Черный • Черен • Crna • Sort • Musta • Μαύρο • Fekete • Svartur • Svart • Czarny • Negru • Čierny • Črna • Černý • Siyah • Чорний • أسود
- R** = Red • Rot • Rouge • Rood • Rojo • Röd • Vermelho • Rosso • Красный • Червен • Crvena • Rød • Punainen • Κόκκινο • Vörös • Rauður • Raud • Czerwony • Roşu • Červený • Rdeča • Červený • Kırmızı • Червоний • أحمر
- L** = Blue • Blau • Bleu • Blauw • Azul • Blå • Azul • Blu • Синий • Син • Plava • Blå • Sininen • Μπλε • Kék • Blár • Blá • Niebieski • Albastru • Modrý • Modra • Modrý • Mavi • Синий • أزرق

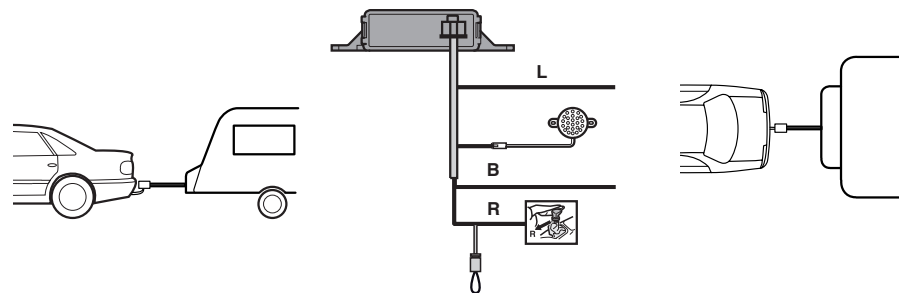
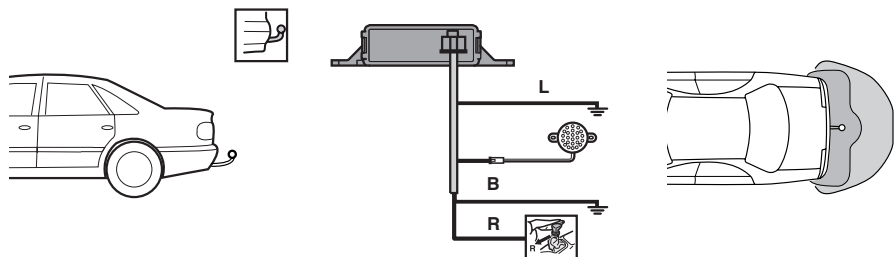
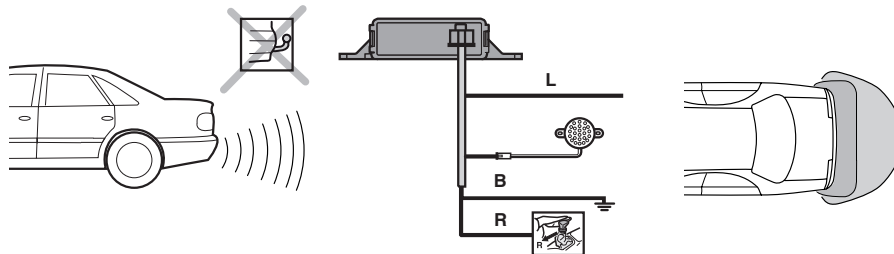

- B** = Black • Schwarz • Noir • Zwart • Negro • Svart • Preto • Nero • Черный • Черен • Crna • Sort • Musta • Μαύρο • Fekete • Svartur • Svart • Czarny • Negru • Čierny • Črna • Černý • Siyah • Чорний • أسود • أسود
- R** = Red • Rot • Rouge • Rood • Rojo • Röd • Vermelho • Rosso • Красный • Червен • Crvena • Rød • Punainen • Κόκκινο • Vörös • Rauður • Raud • Czerwony • Roşu • Červený • Rdeča • Červený • Kırmızı • Червоний • أحمر • أحمر
- L** = Blue • Blau • Bleu • Blauw • Azul • Blå • Azul • Blu • Синий • Син • Plava • Blå • Sininen • Μπλε • Kék • Blár • Blá • Niebieski • Albastru • Modrý • Modra • Modrý • Mavi • Синій • नील • أزرق

CONFIGURATION

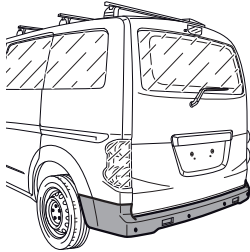

		<b>sensitivity</b> 		
<b>DEFAULT</b>				
<b>e-NV200</b>				

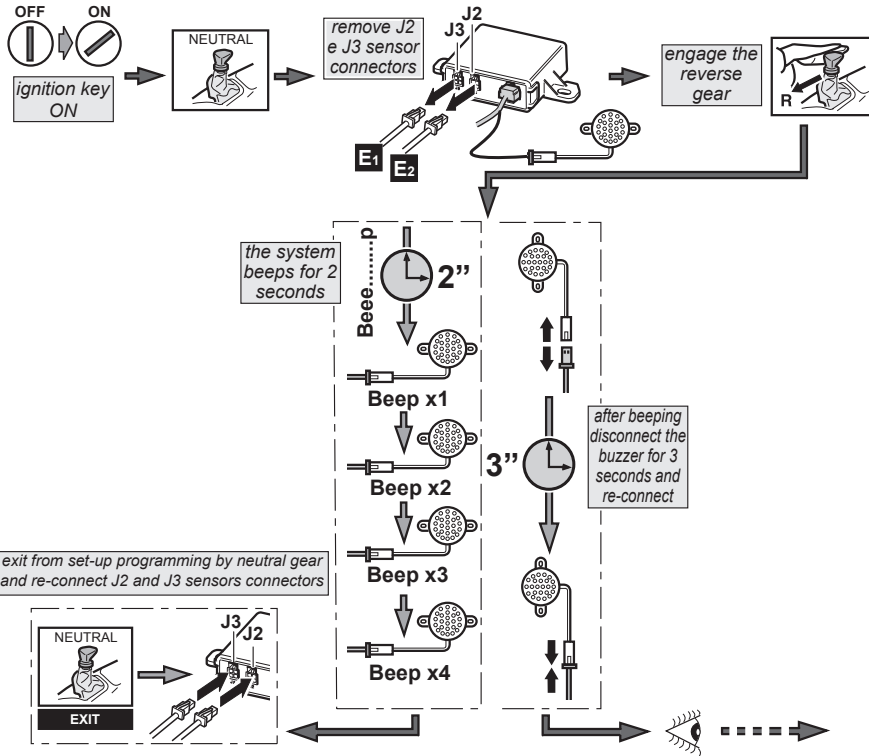



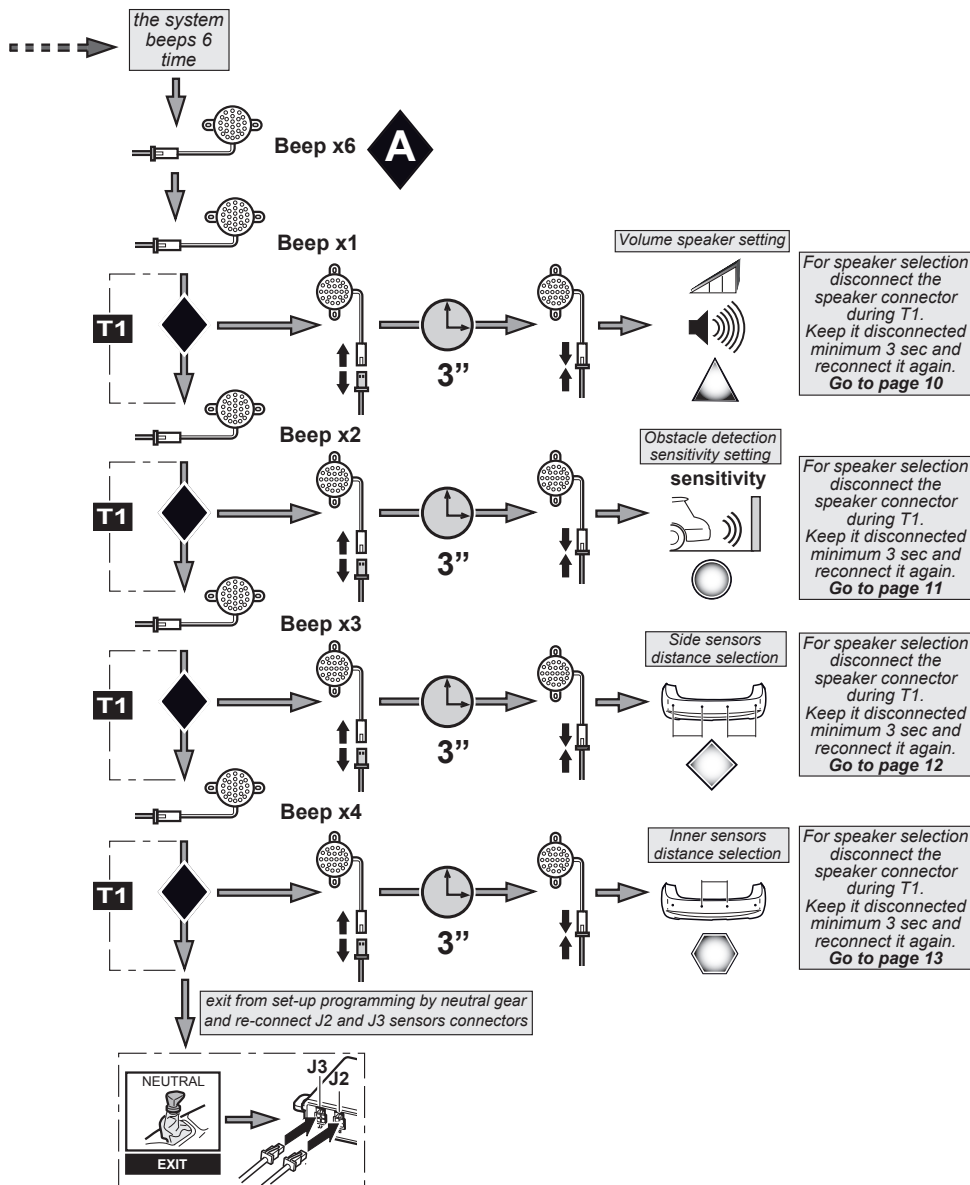

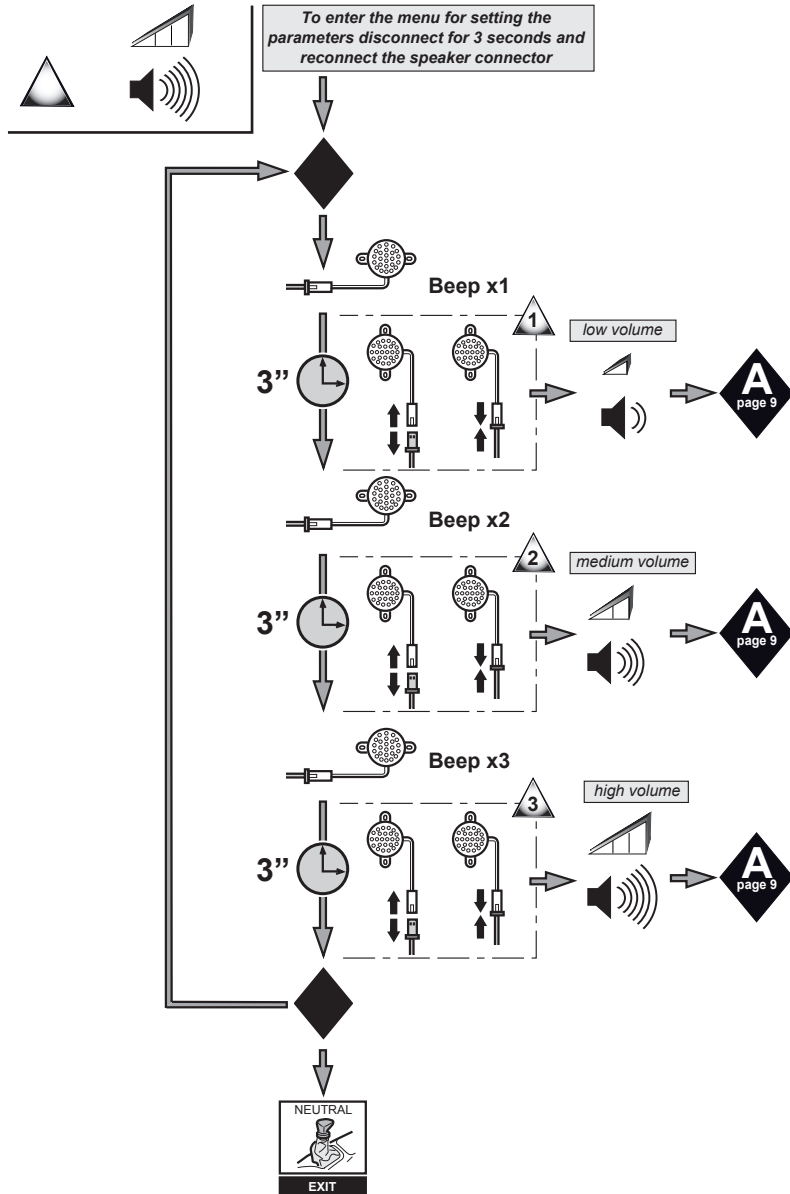

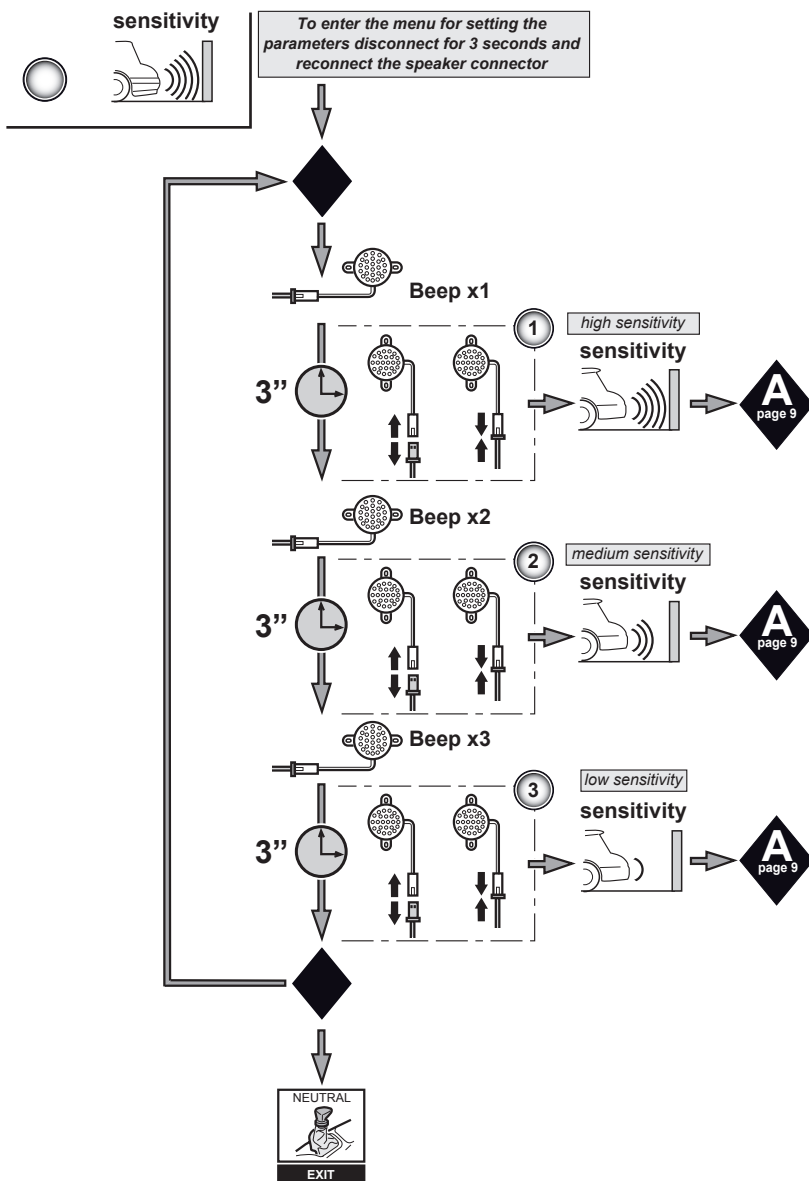

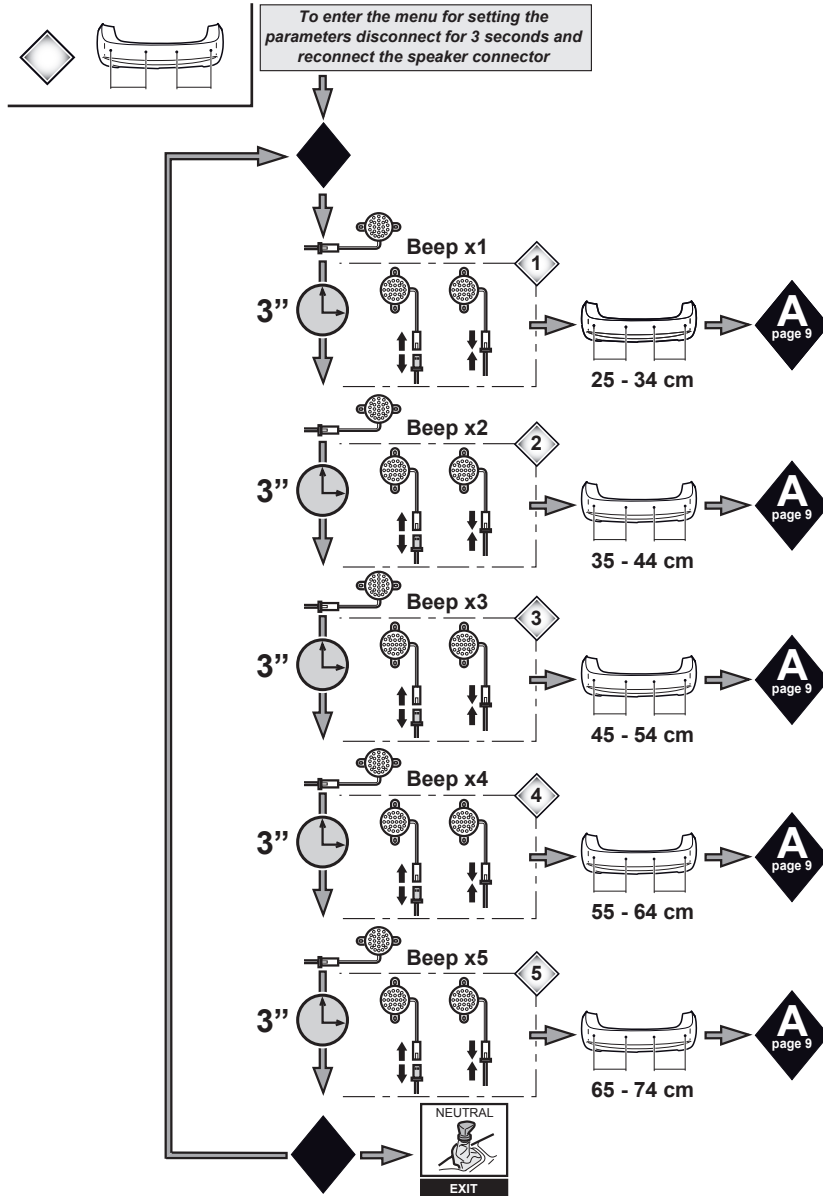

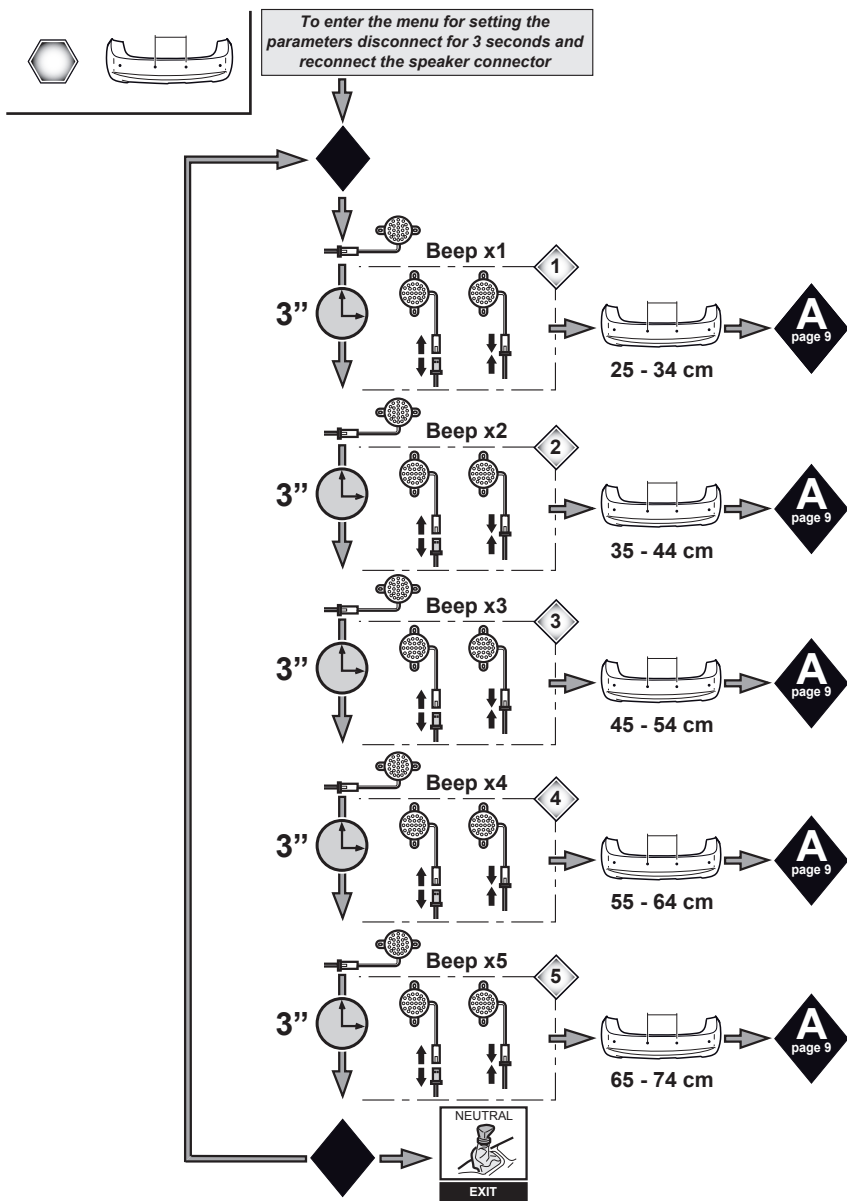

**NISSAN**

---



# e-NV200 (VAN/COMBI & LUDOSPACE) (ME0)

05 - '14 →

1

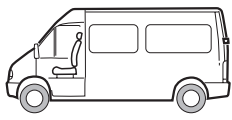

(VAN)

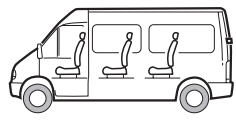

(COMBI & LUDOSPACE)

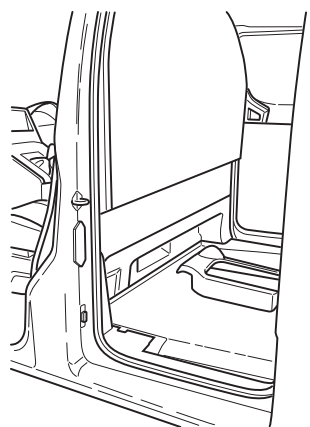
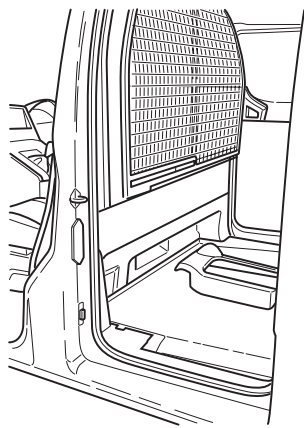
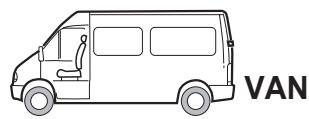

x1 KE511-99991  
(OPTIONAL)



+

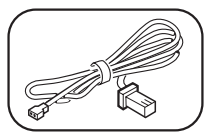

18

18A

2

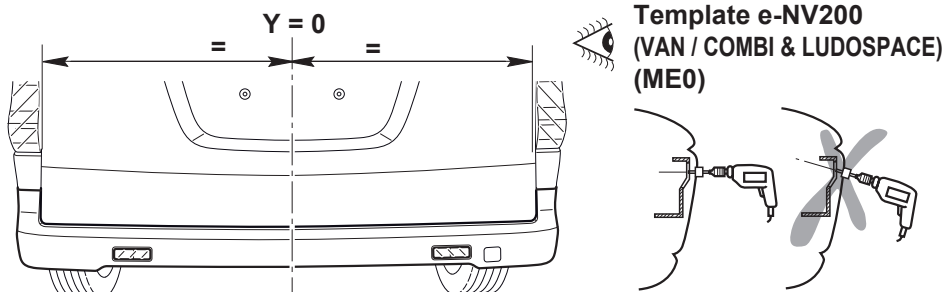

Template e-NV200  
(VAN / COMBI & LUDOSPACE)  
(ME0)

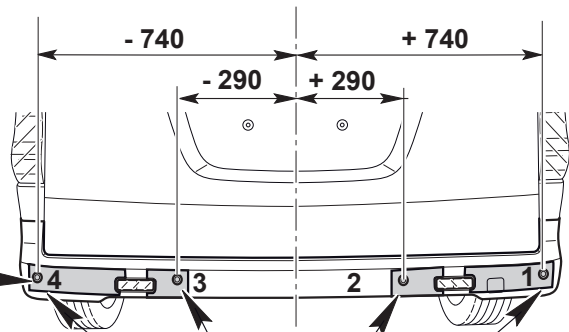
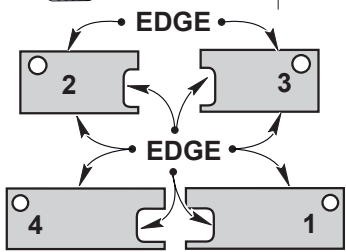

<p><b>1</b> Ø 2 mm</p> <p>x4</p>	<p><b>2</b> Ø 20 mm</p>	<p><b>3</b></p>	<p><b>4</b></p> <p>⚠️ Ø 20 mm ☺️ Ø &lt; 20 mm</p>
----------------------------------	-------------------------	-----------------	---



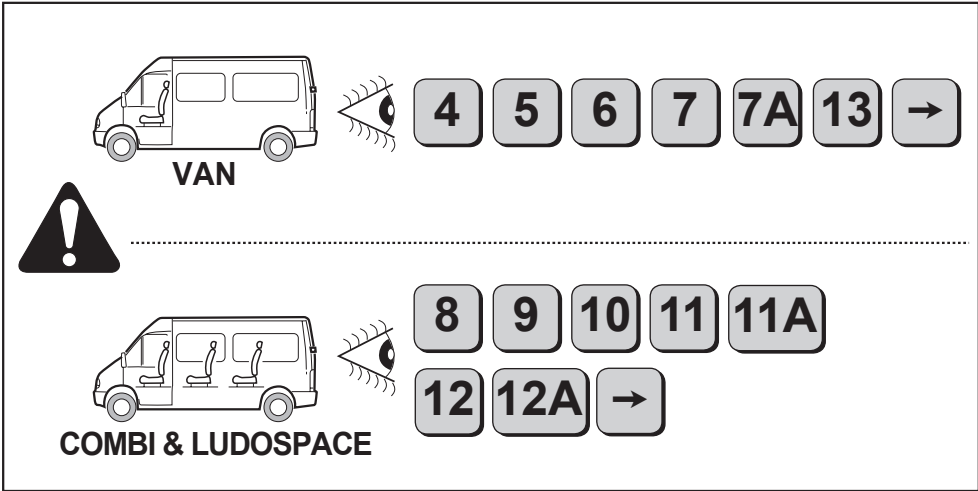

4

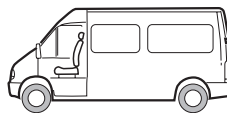

VAN

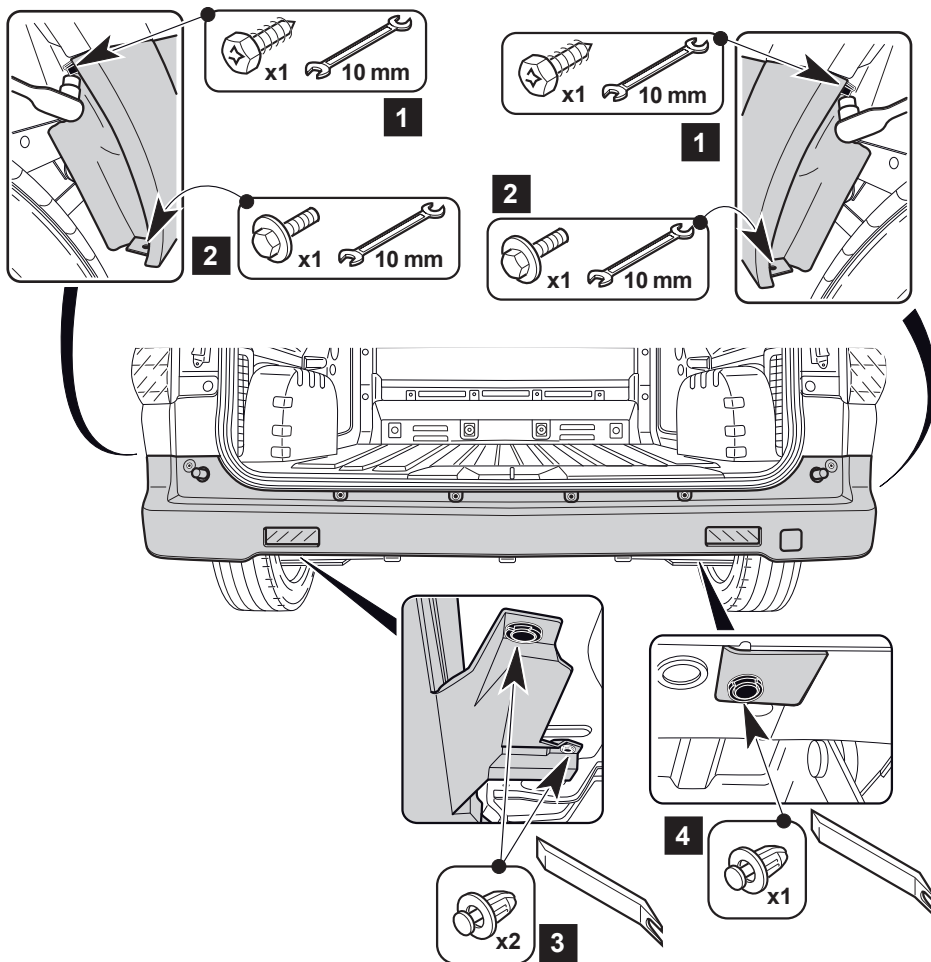

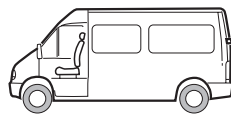

5

VAN

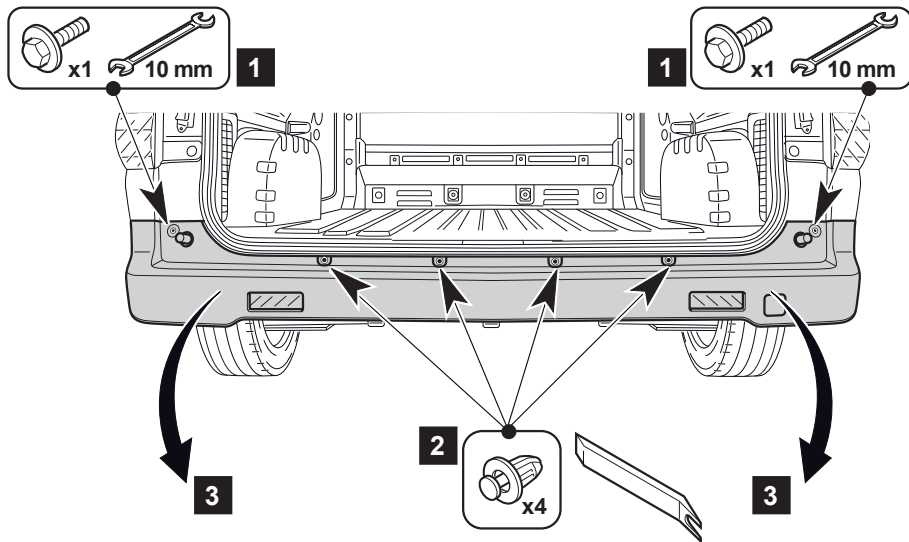

6

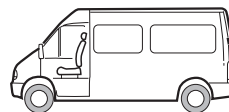

VAN

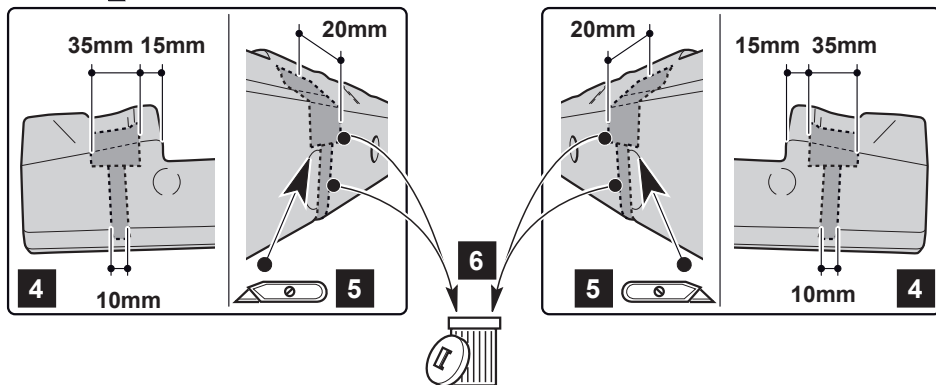
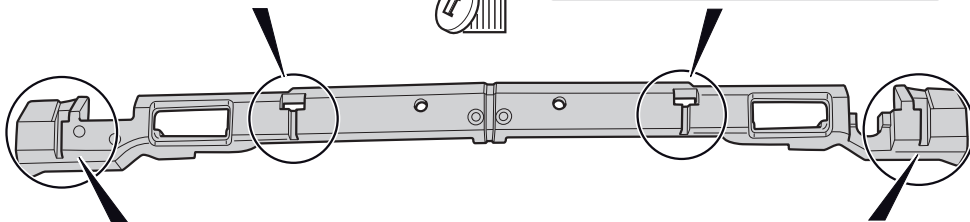
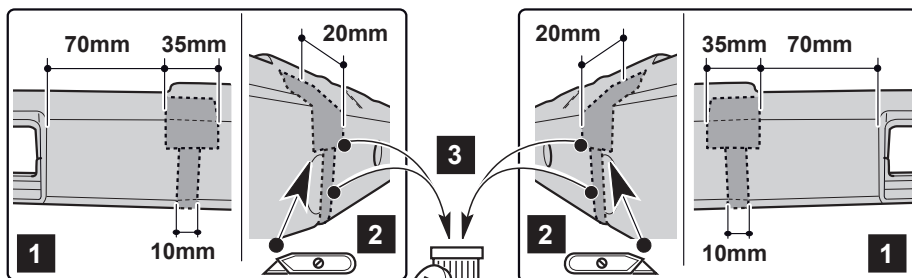

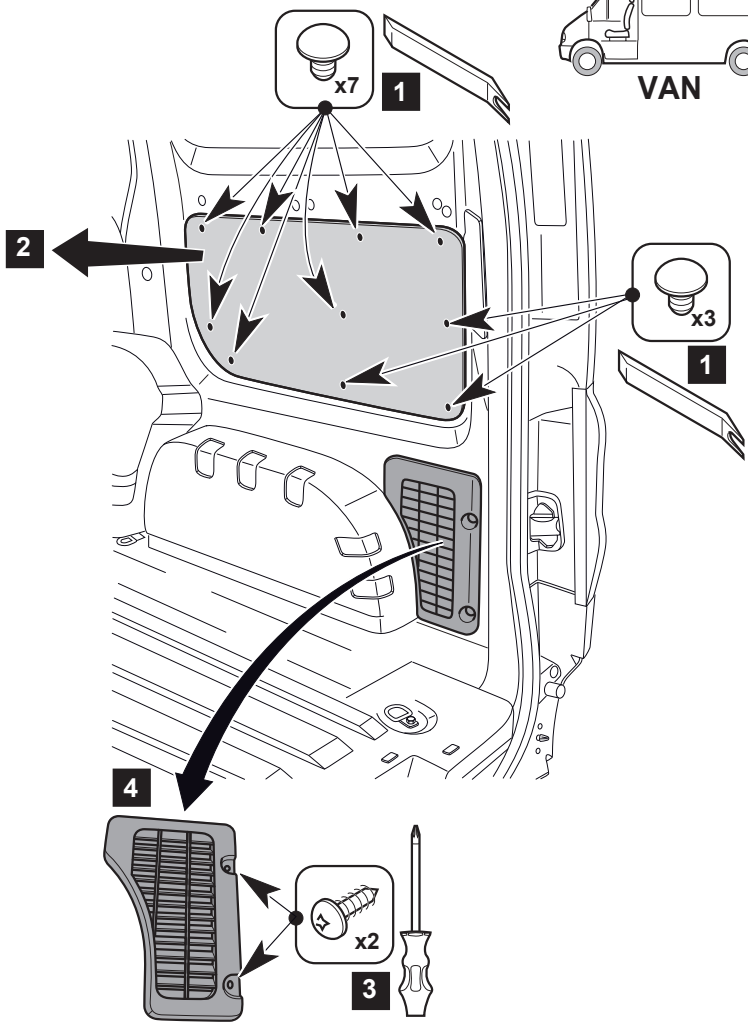
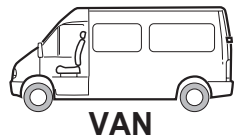

**7A** RHD

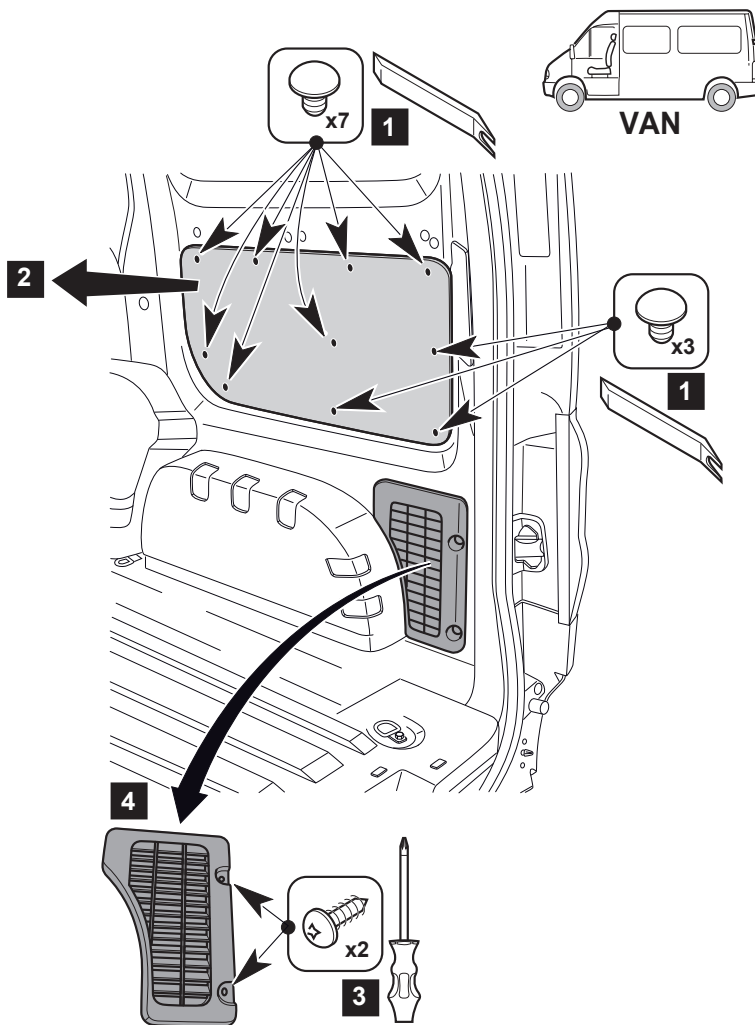

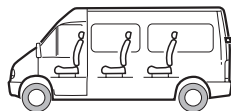

COMBI & LUDOSPACE

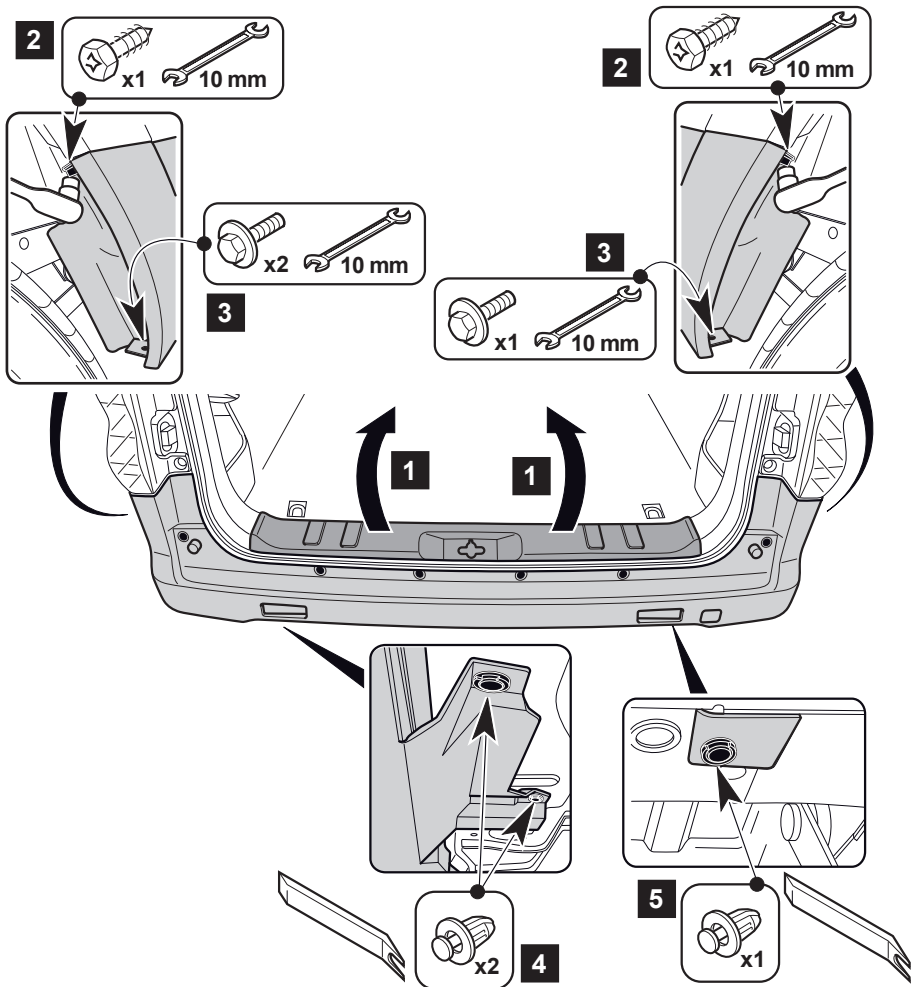

9

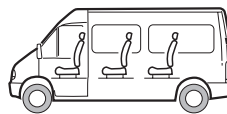

COMBI & LUDOSPACE

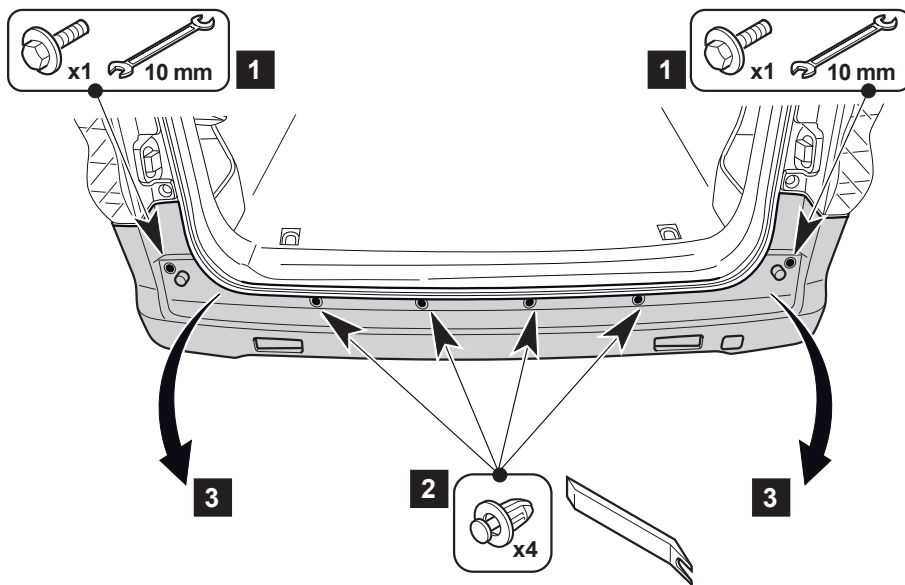



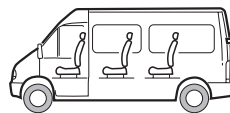

10

COMBI & LUDOSPACE

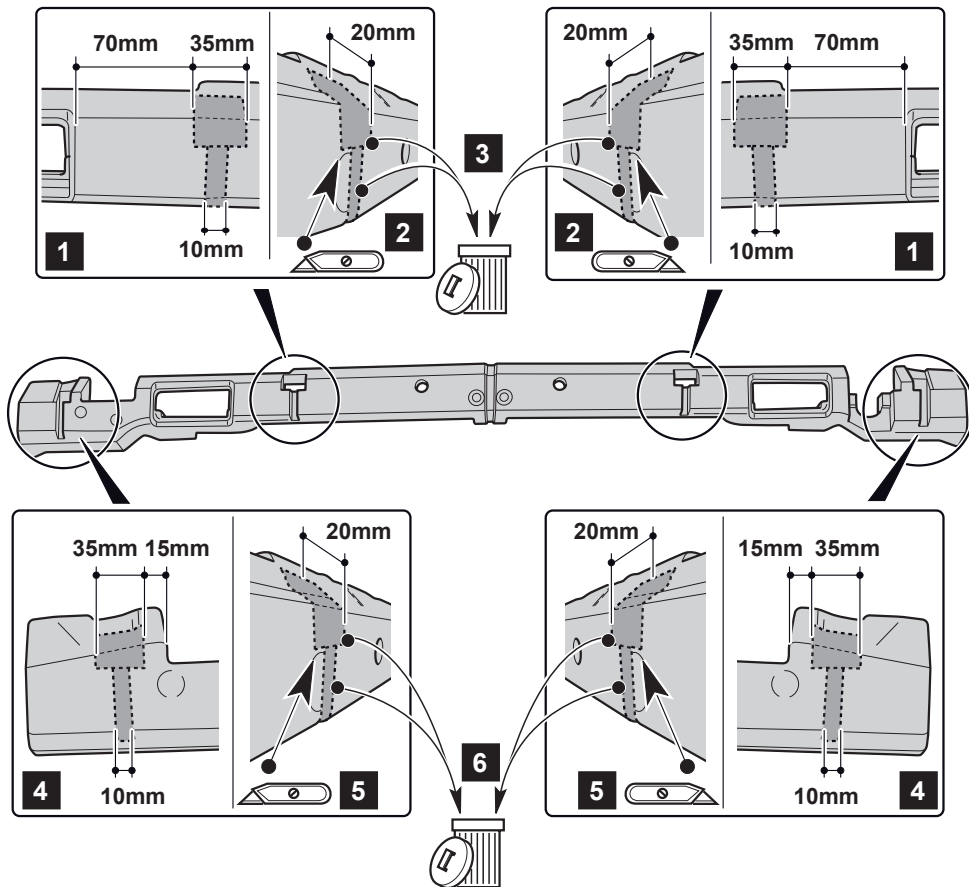

**11** LHD

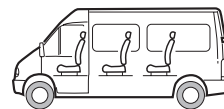

**COMBI & LUDOSPACE**

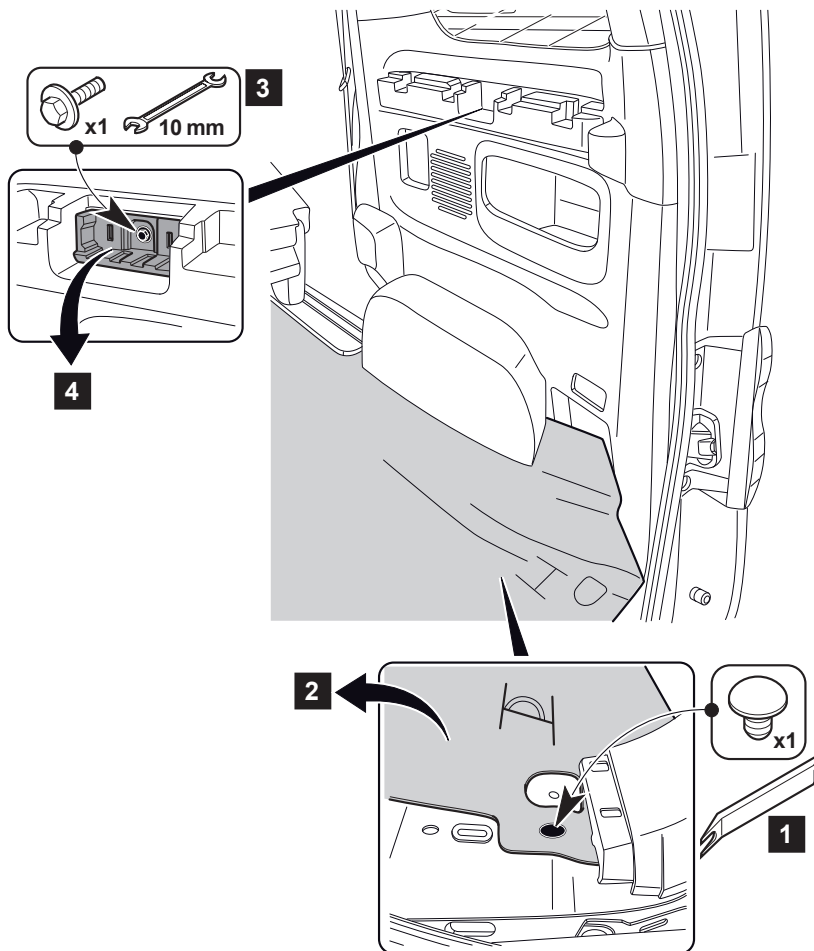

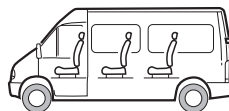

RHD

11A

COMBI & LUDOSPACE

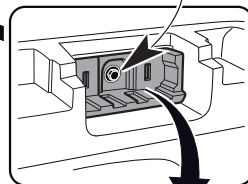
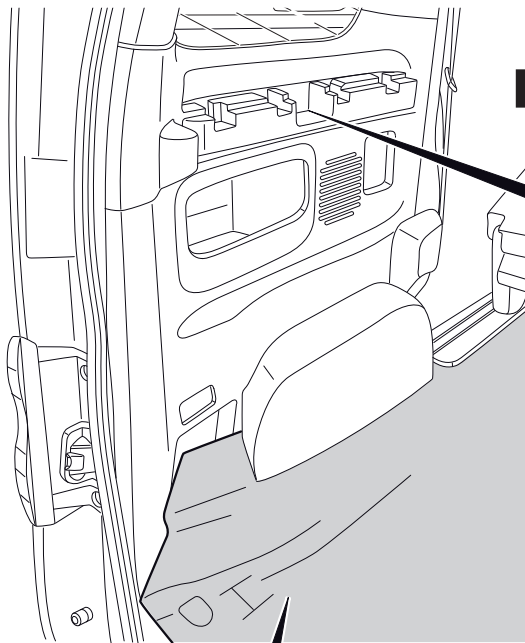

4

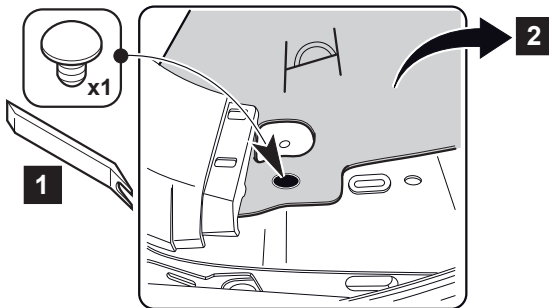

1

2

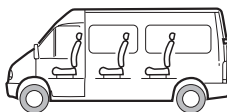

COMBI & LUDOSPACE

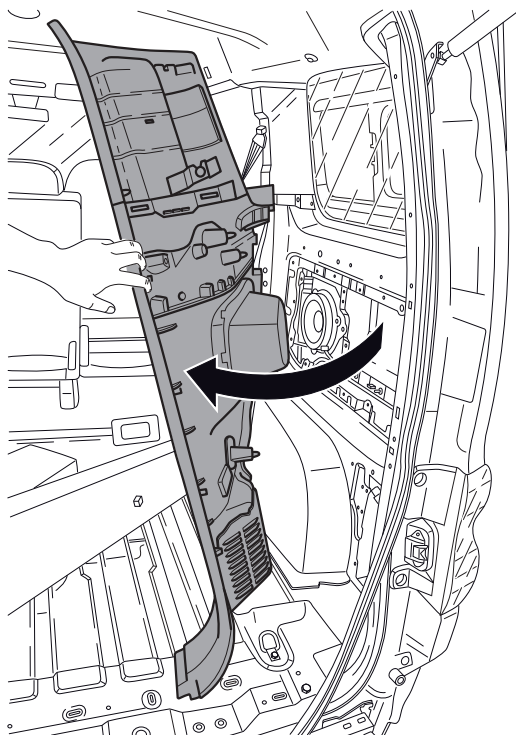

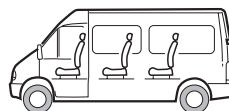

RHD

12A

COMBI & LUDOSPACE

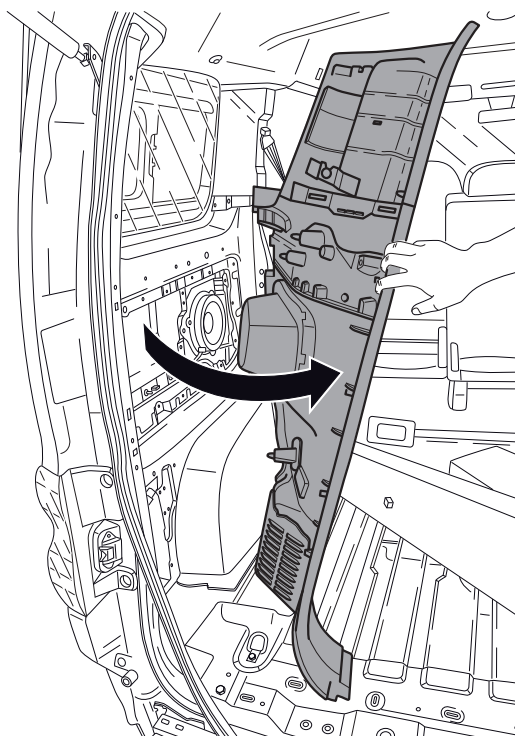

13

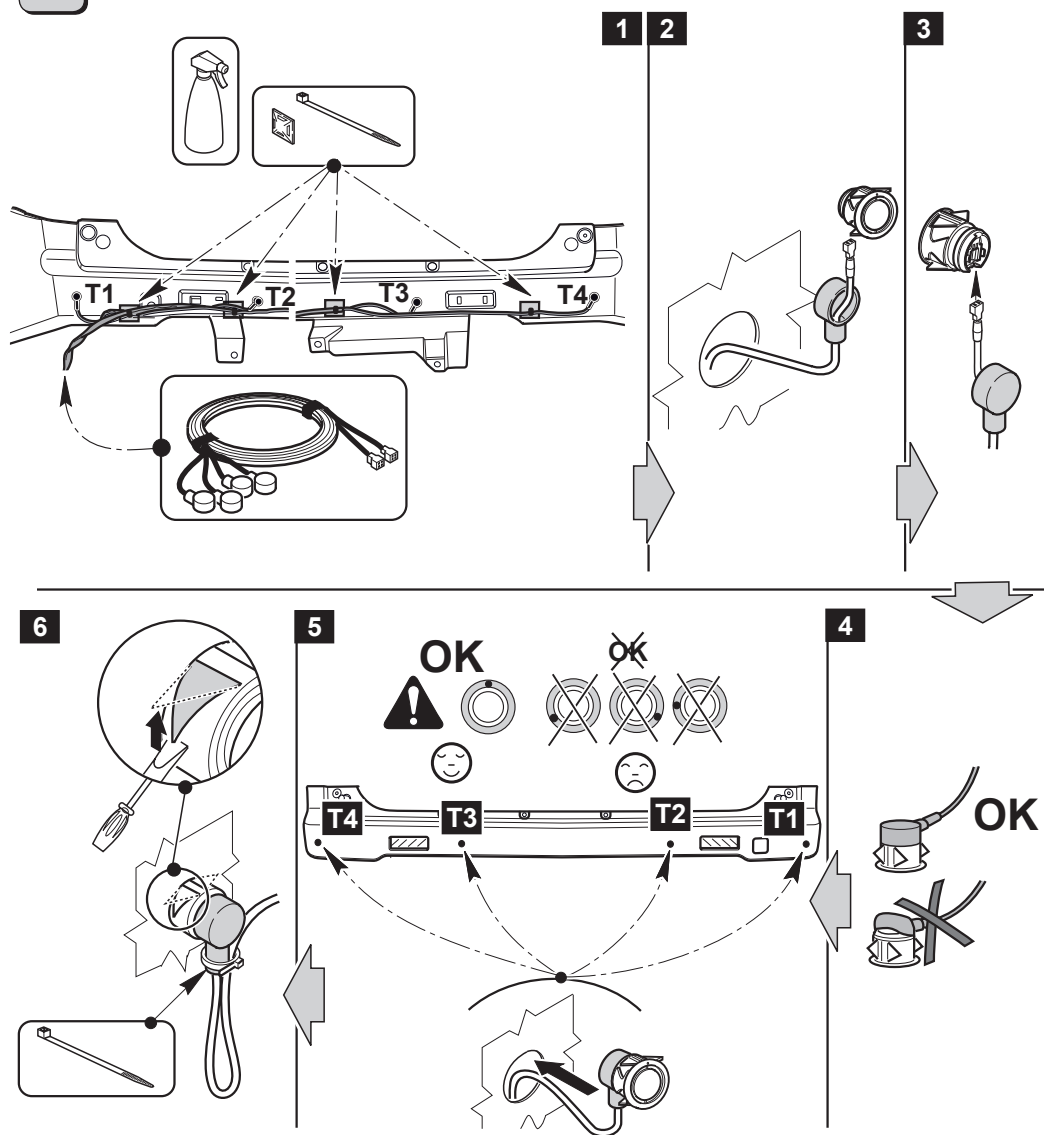

RHD

Template e-NV200  
(VAN / COMBI & LUDOSPACE)  
(ME0)

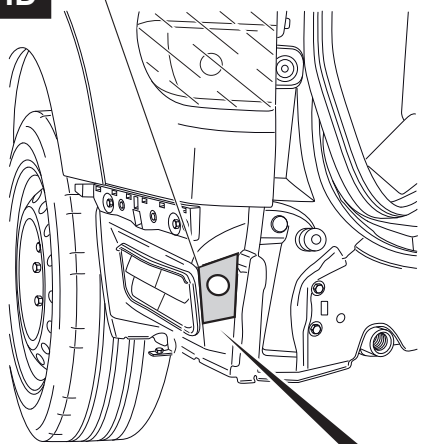

Template e-NV200  
(VAN / COMBI & LUDOSPACE)  
(ME0)

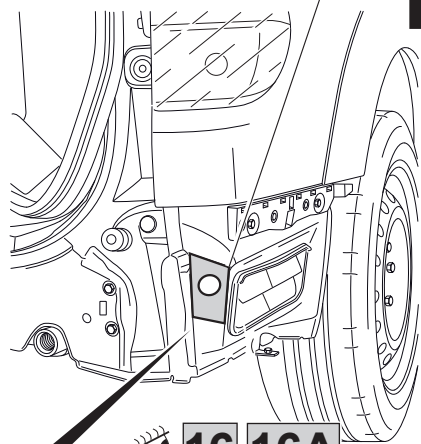

LHD

16 16A

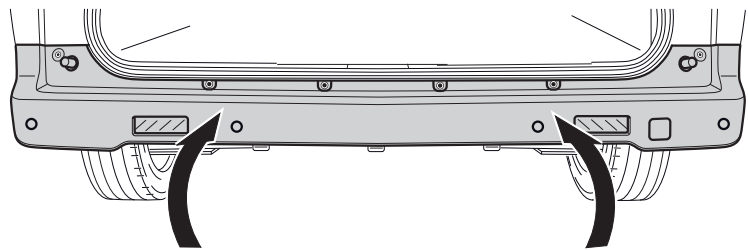
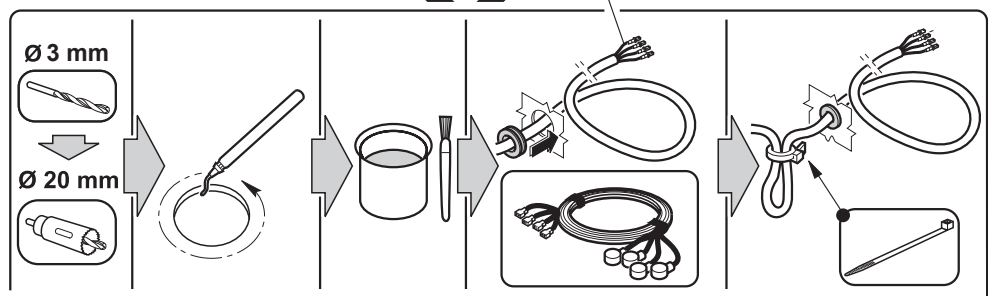

16 LHD

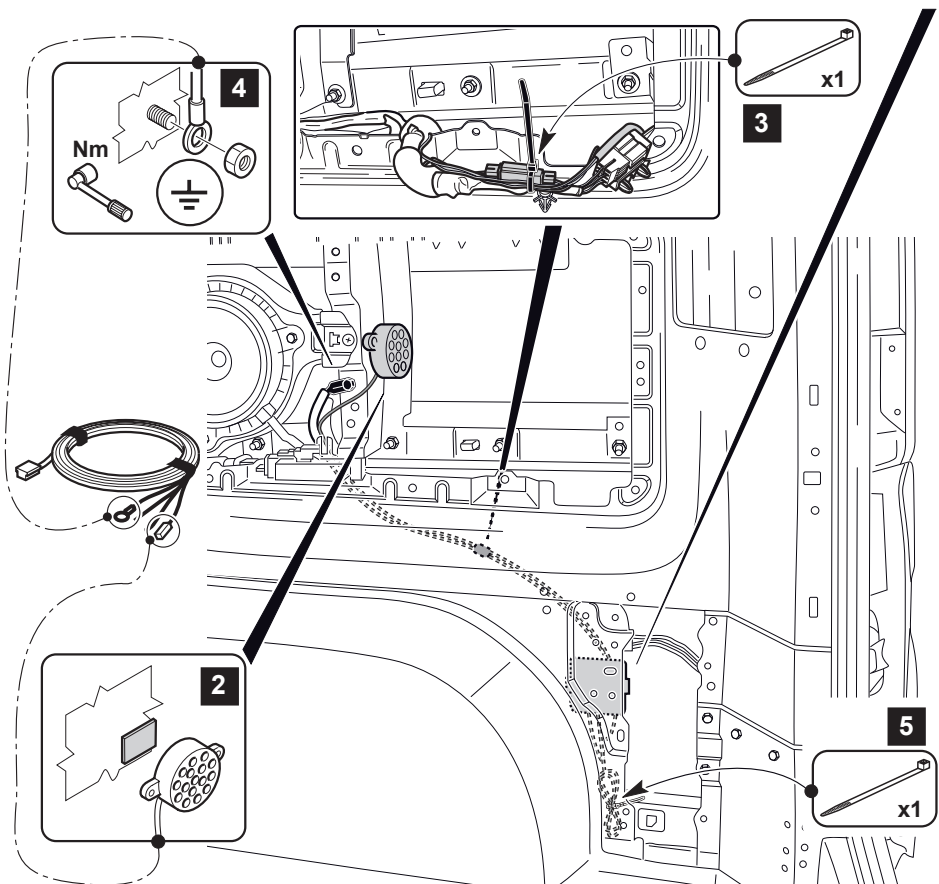
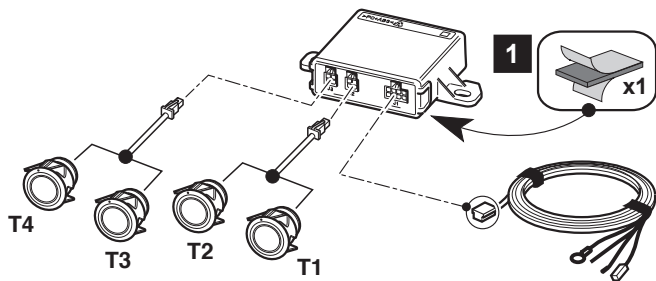



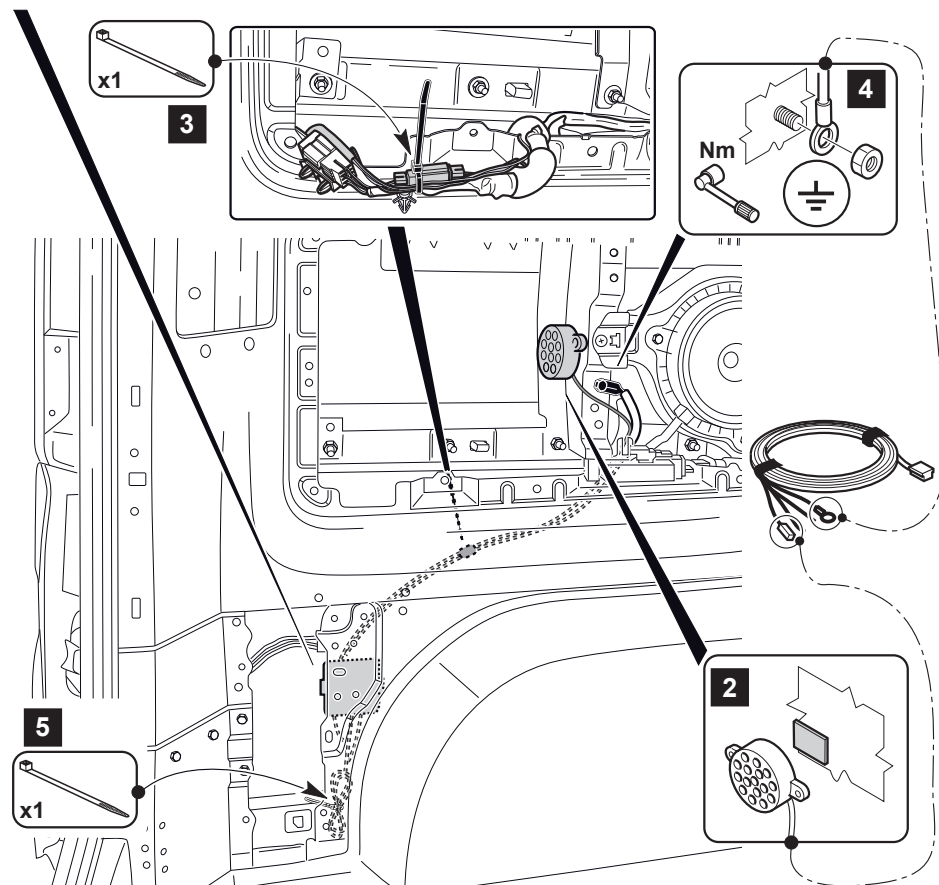
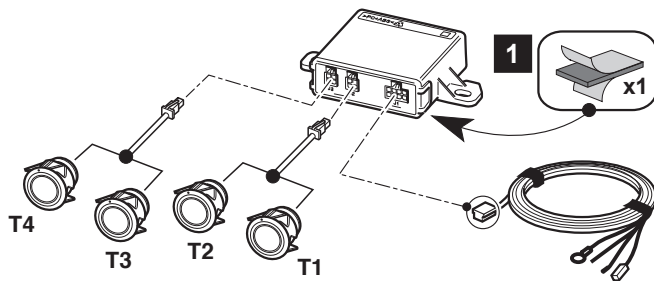

17

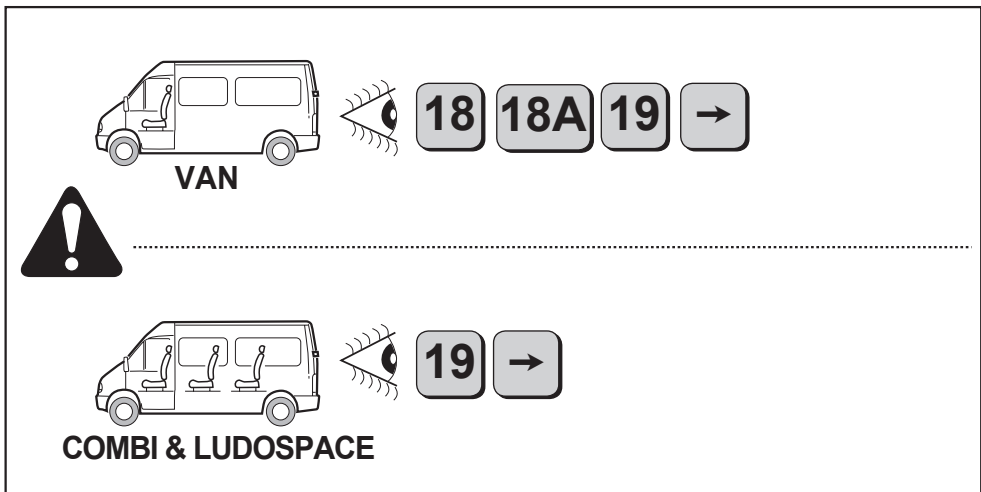

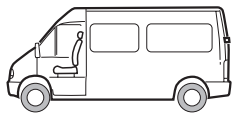

VAN

OPTIONAL KE511-99991

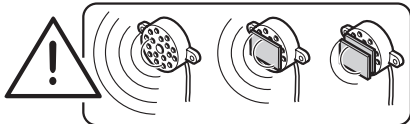
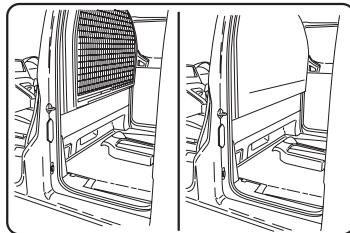
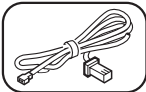

1

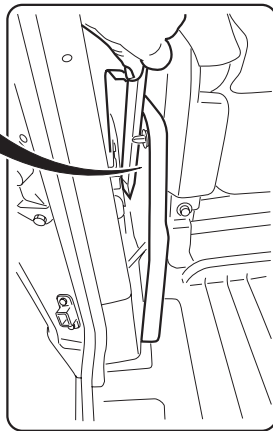
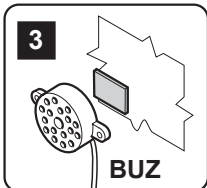

x1 KE511-99991

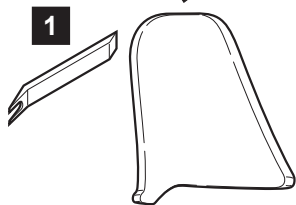
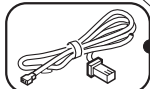

**18A RHD**

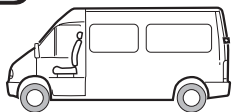

VAN

OPTIONAL KE511-99991

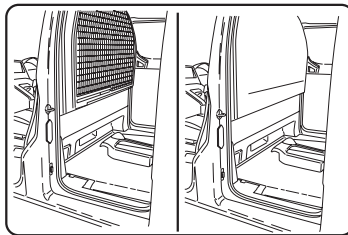
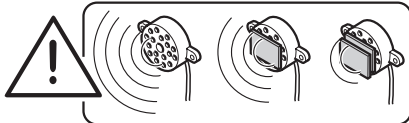
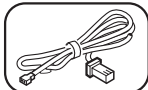

**1**

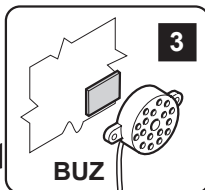
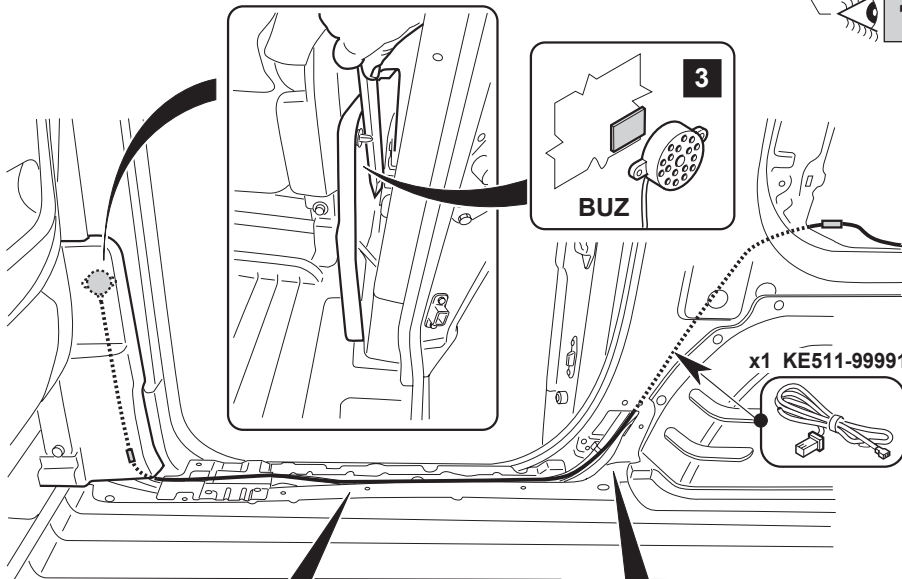

BUZ

x1 KE511-99991

**1**



**2**



x2

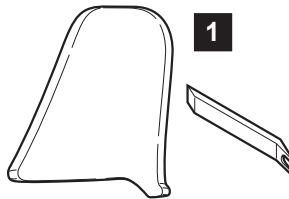

19

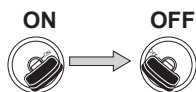
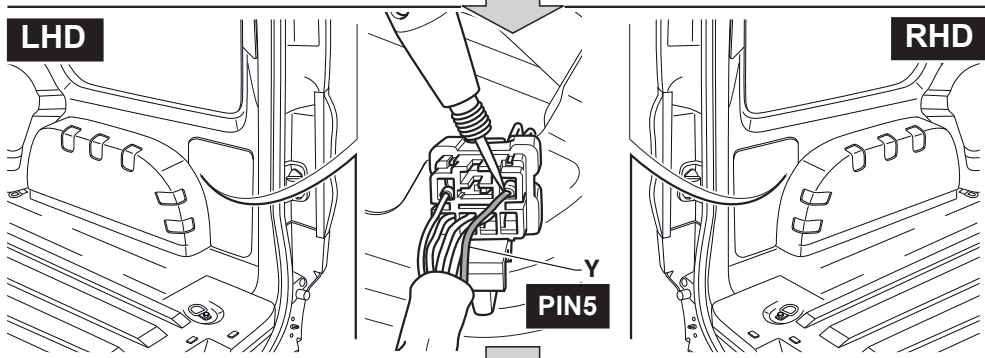
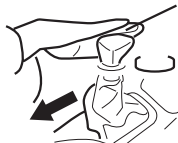
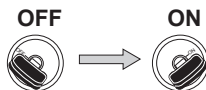

20

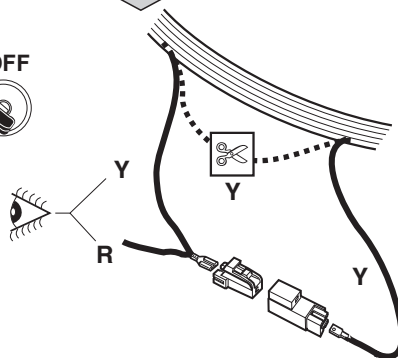

20

Y = Yellow • Gelb • Jaune • Gell • Amarillo • Amarelo • Gul • Giallo • Желто • жълт • ŽUTI • GUL • KELTAINEN • κίτρινος • SÁRGA • LJÓSGRÆNN • nyrosk • ŻÓŁTY • GALBEN • žltý • rumeno • ŽLUTÁ • SARI • Жовтий • بوهض • أزرق

R = Red • Rot • Rouge • Rood • Rojo • Röd • Vermelho • Rosso • Красный • Червен • Crvena • Rød • Punainen • Κόκκινο • Vörös • Rauður • Raud • Czerwony • Roşu • Červený • Rdeča • Červený • Kırmızı • Червоний • أحمر • ادم

**VAN**

22 22A 26 →

**COMBI & LUDOSPACE**

23 23A 24 24A  
25 26 →

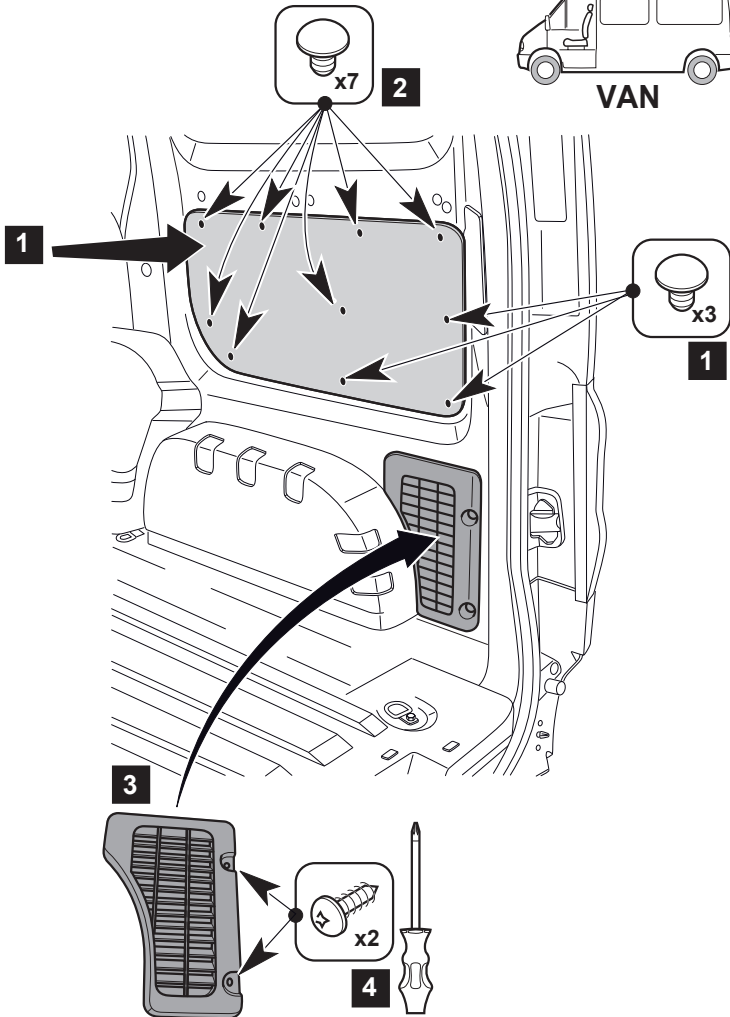
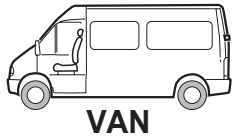

22A

RHD

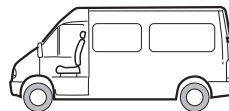

VAN

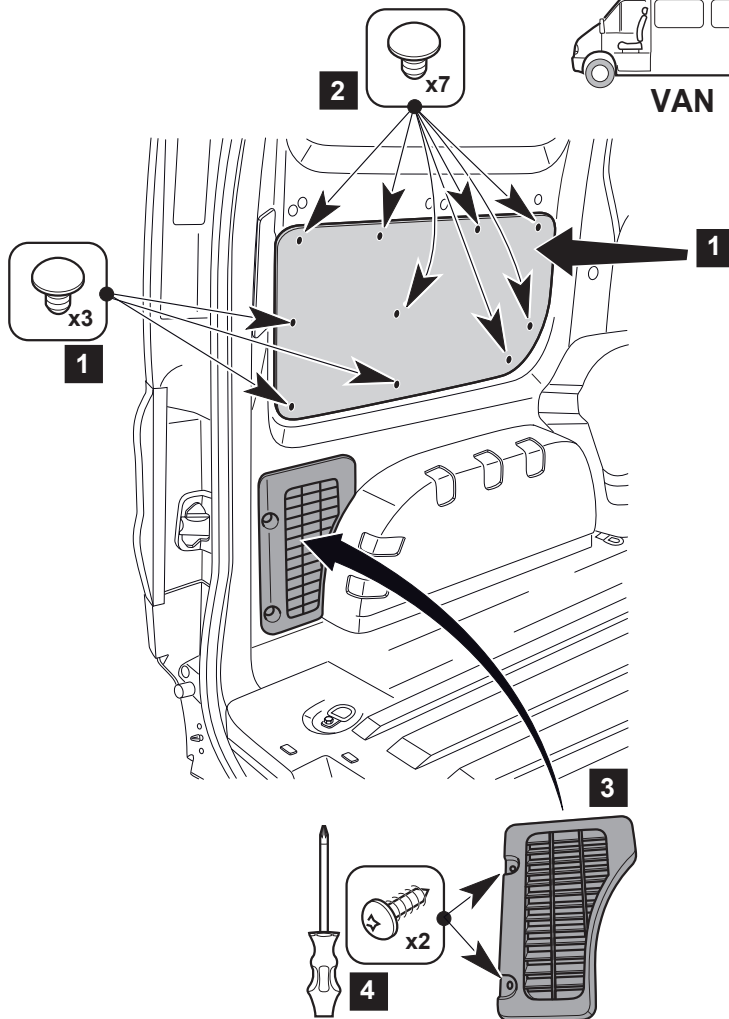



LHD

23

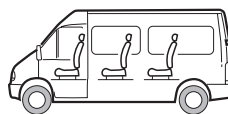

COMBI & LUDOSPACE

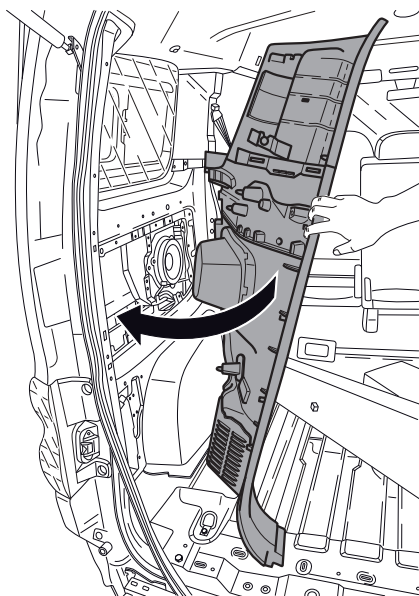

RHD

23A

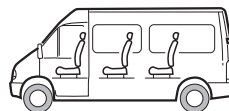

COMBI & LUDOSPACE

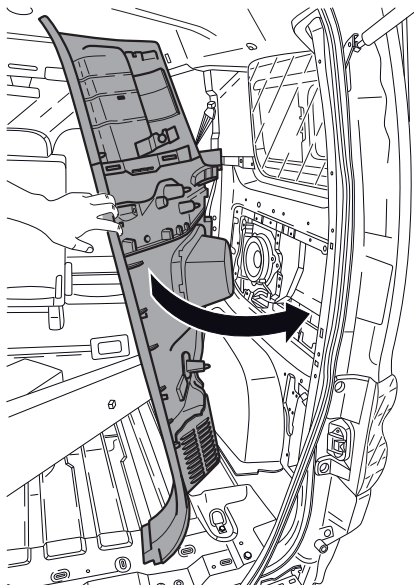

**24** LHD

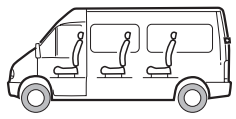
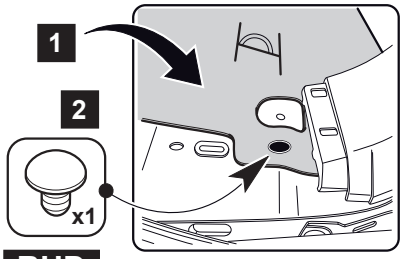
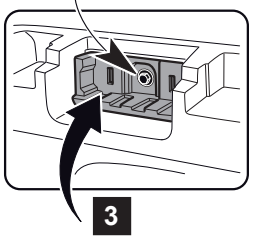

COMBI & LUDOSPACE

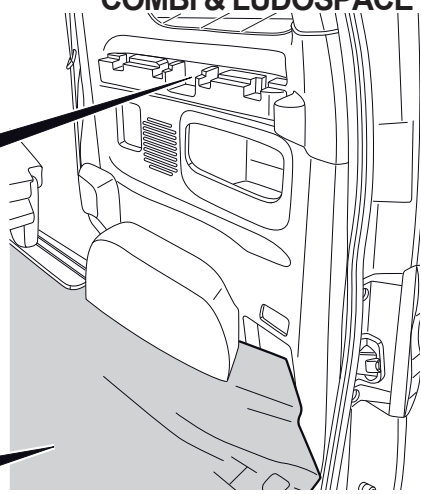

**24A** RHD

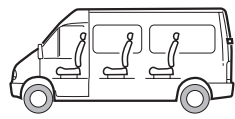
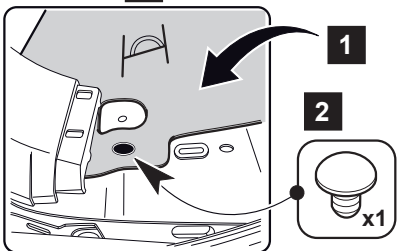
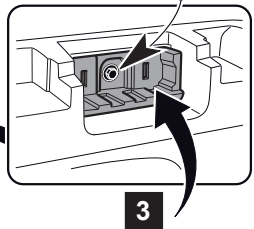

COMBI & LUDOSPACE

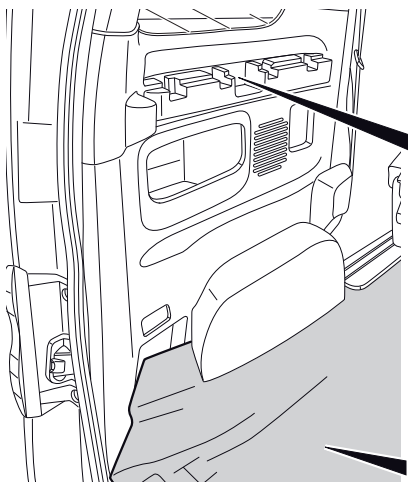

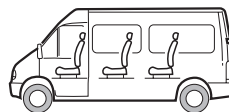

COMBI & LUDOSPACE

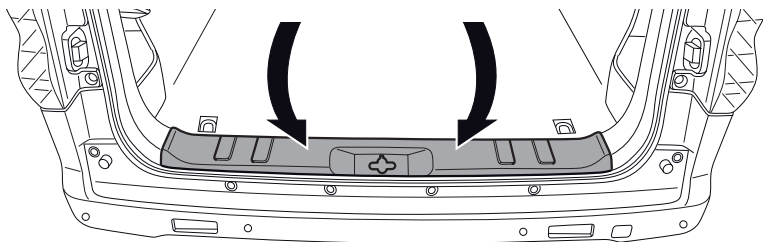



# **NISSAN**

**NISSAN INTERNATIONAL S.A.**

Printed in Italy  
Cod. 06DE3917A date 04/2014

---



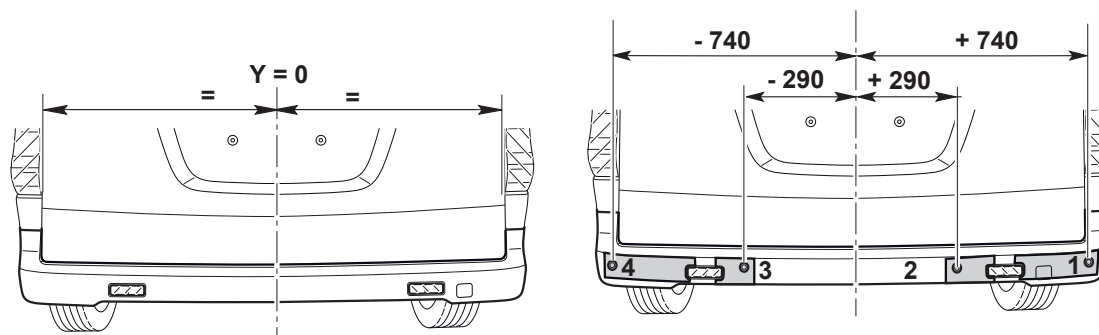
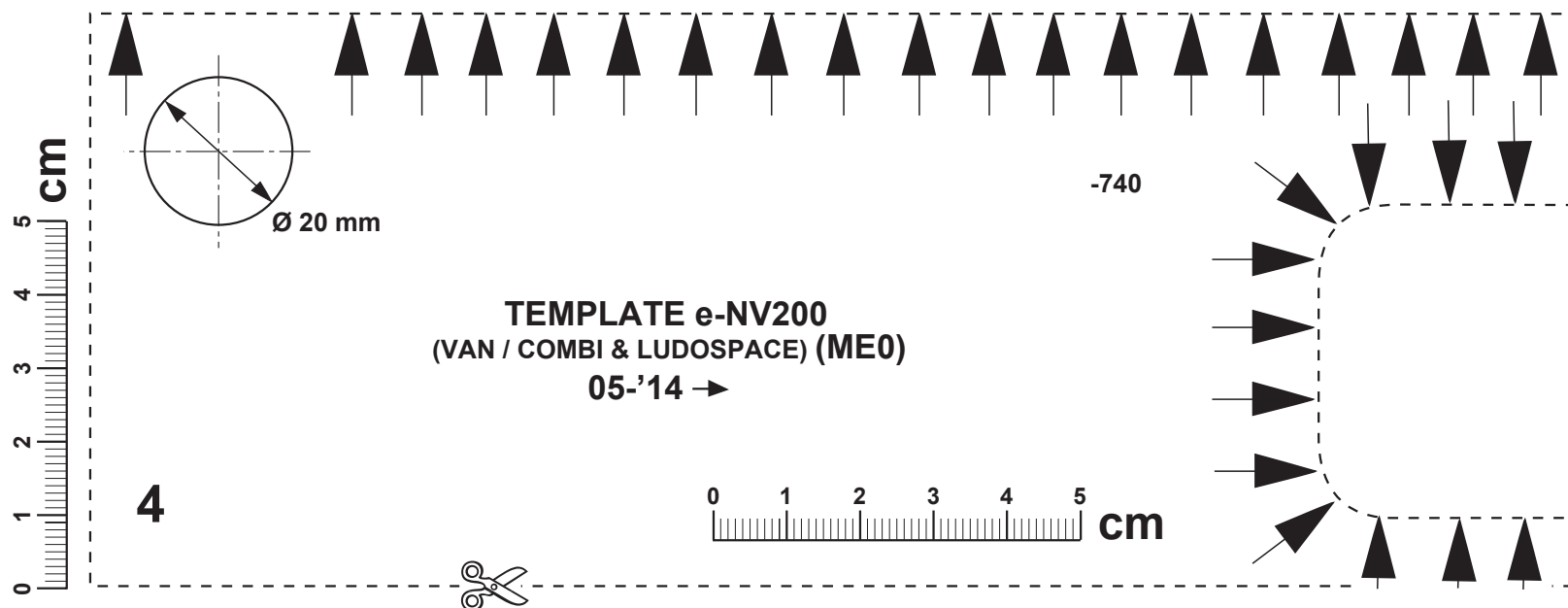



**NISSAN**



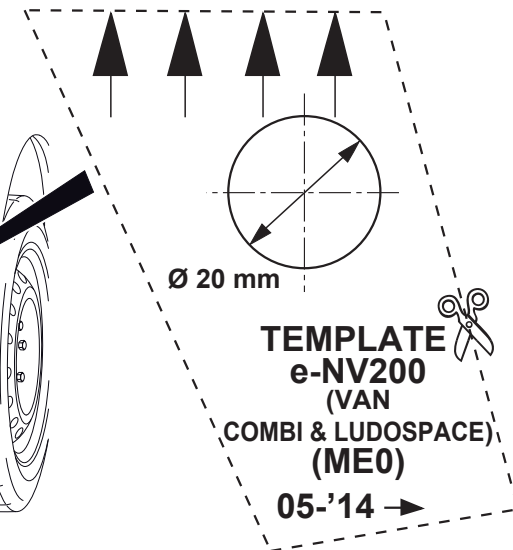
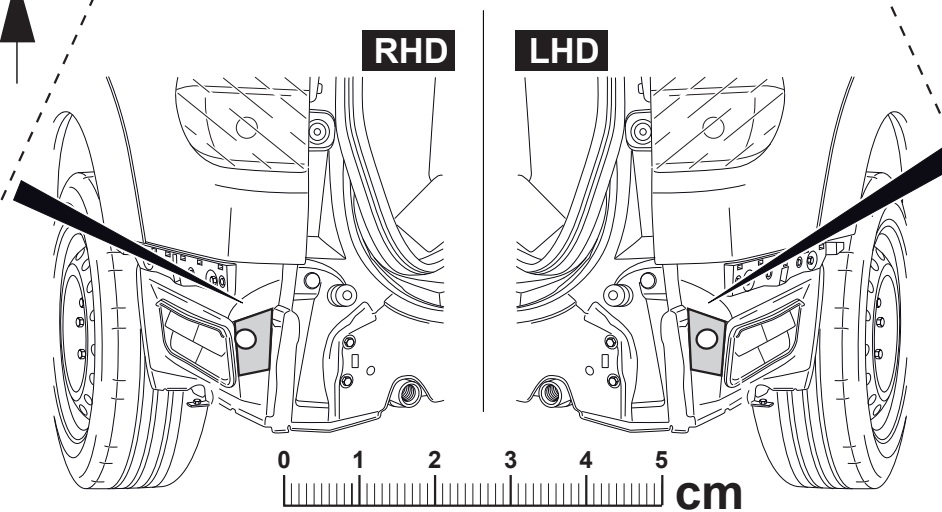
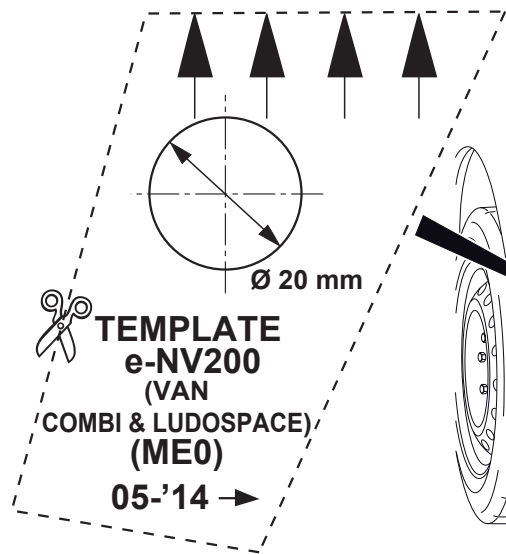
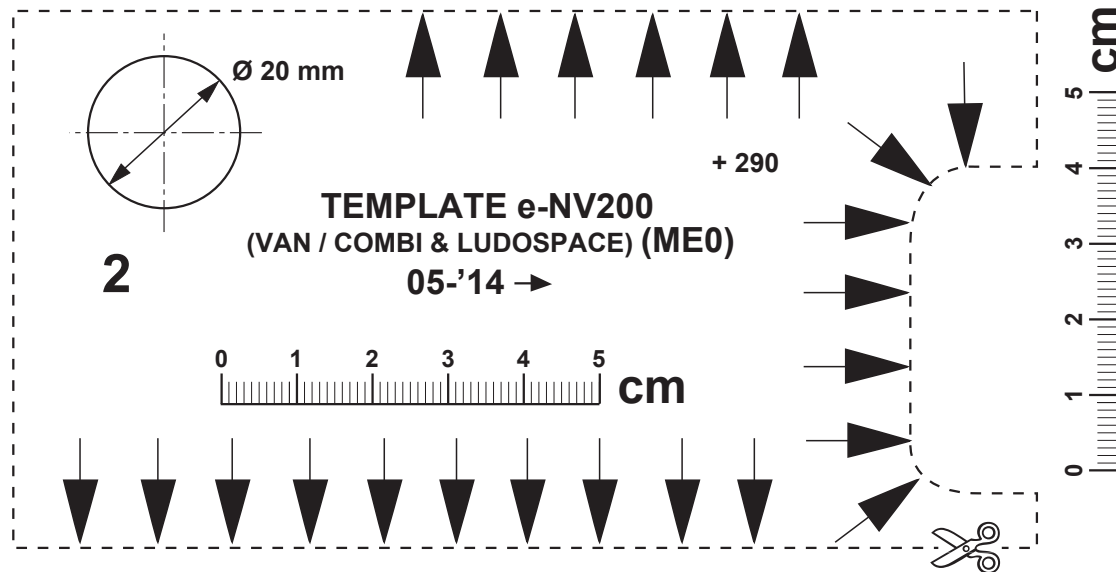
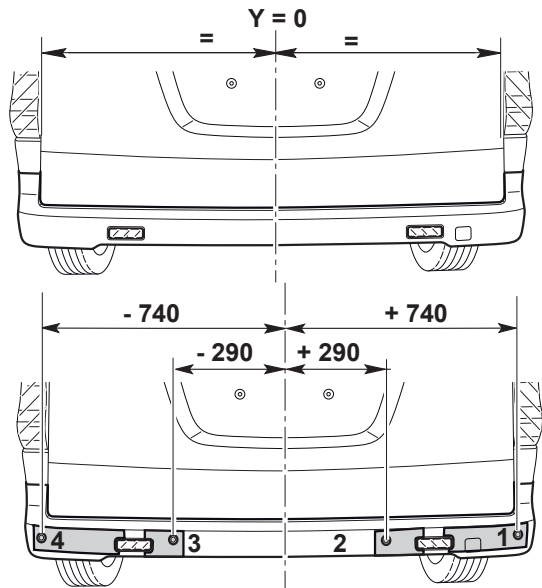



**NISSAN**





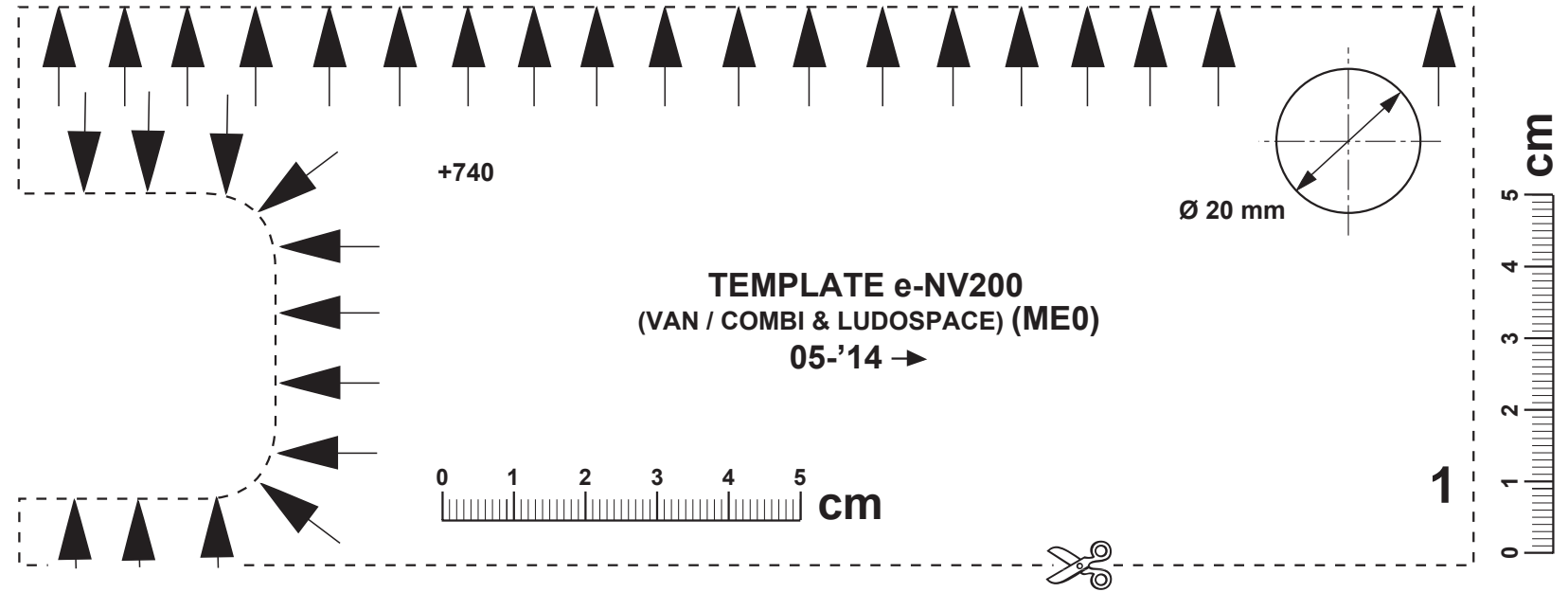
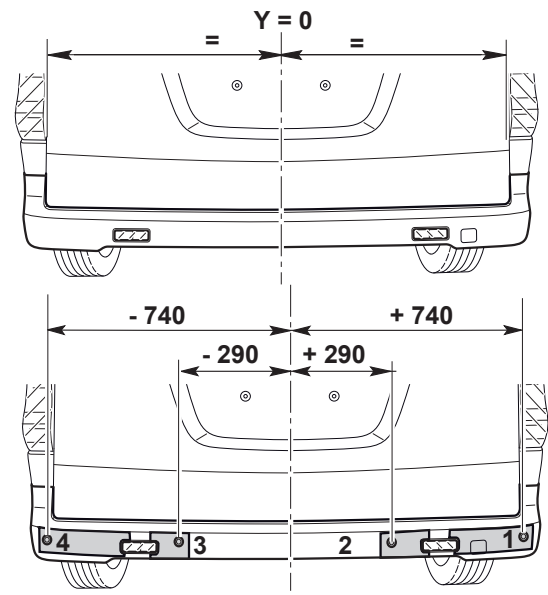
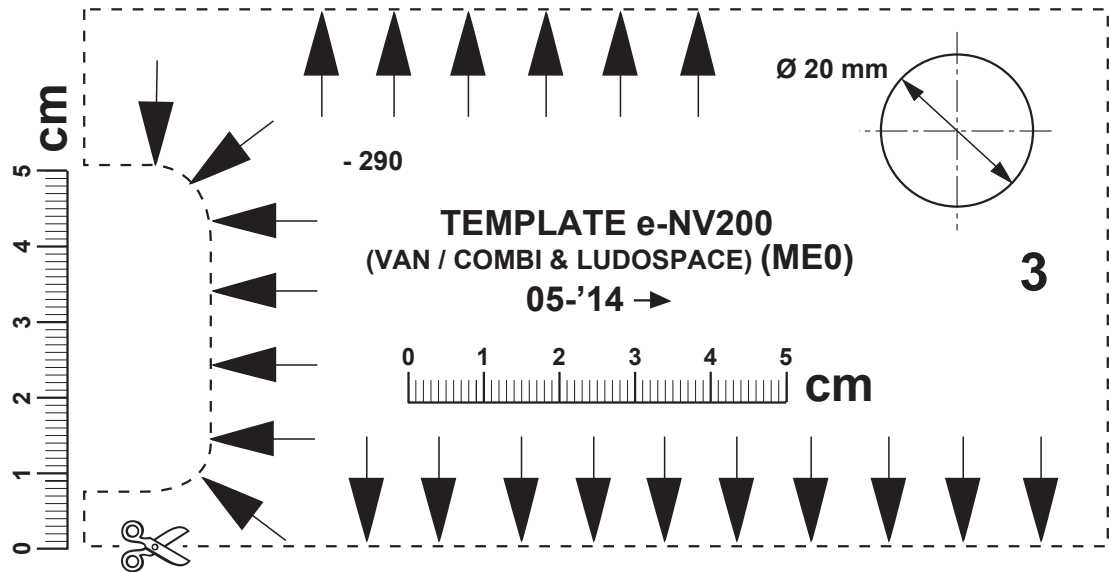



**NISSAN**

