

Lecture 07 Introduction to the MIPS ISA

Motivation: Why MIPS?

- Shortcomings of the simple processor
 - Only 16 bits for data and instruction
 - Data range can be too small
 - Addressable memory is small
 - Only support at most 16 instructions
- MIPS ISA: 32-bit RISC processor
 - A representative RISC ISA
 - (RISC – Reduced Instruction Set Computer)
 - A fixed-length, regularly encoded instruction set and uses a load/store data model
 - Used by NEC, Cisco, Silicon Graphics, Sony, Nintendo

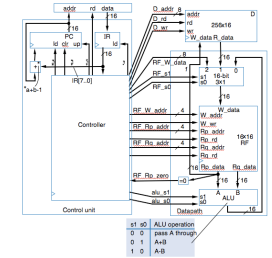

MIPS vs. The 6-instruction Processor

A quick look: more complex ISAs

Instruction Encoding

6-instruction processor:

Add instruction: **0010 ra₃ra₂ra₁ra₀ rb₃rb₂rb₁rb₀ rc₃rc₂rc₁rc₀**

Add Ra, Rb, Rc— specifies the operation $RF[a]=RF[b] + RF[c]$

MIPS processor:

Assembly: **add \$9, \$7, \$8 # add rd, rs, rt: $RF[rd] = RF[rs]+RF[rt]$**

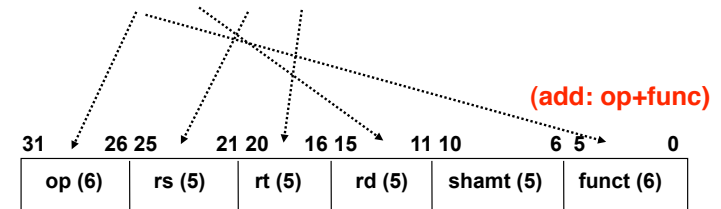

Machine:

B: 000000 00111 01000 01001 xxxxx 100000
 D: 0 7 8 9 x 32

A quick look: more complex ISAs

Instruction Encoding

6-instruction processor:

Sub instruction: **0010** $ra_3ra_2ra_1ra_0$ $rb_3rb_2rb_1rb_0$ $rc_3rc_2rc_1rc_0$
SUB Ra, Rb, Rc—specifies the operation $RF[a]=RF[b]-RF[c]$

A MIPS subtract

Assembly: **sub \$9, \$7, \$8** # sub rd, rs, rt: $RF[rd] = RF[rs]-RF[rt]$

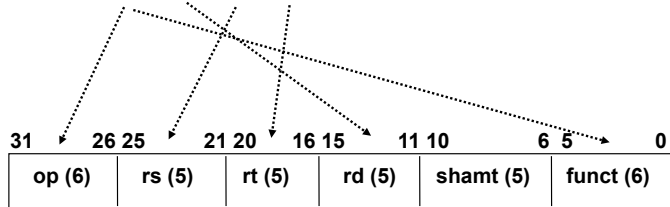

Machine:

B: 000000 00111 01000 01001 xxxxx 100010
 D: 0 7 8 9 x 34

A quick look: more complex ISAs

Datapath

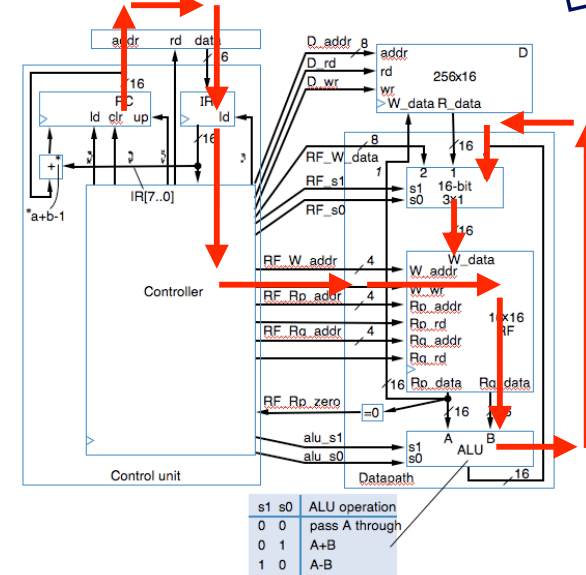

A quick look: more complex ISAs

Datapath

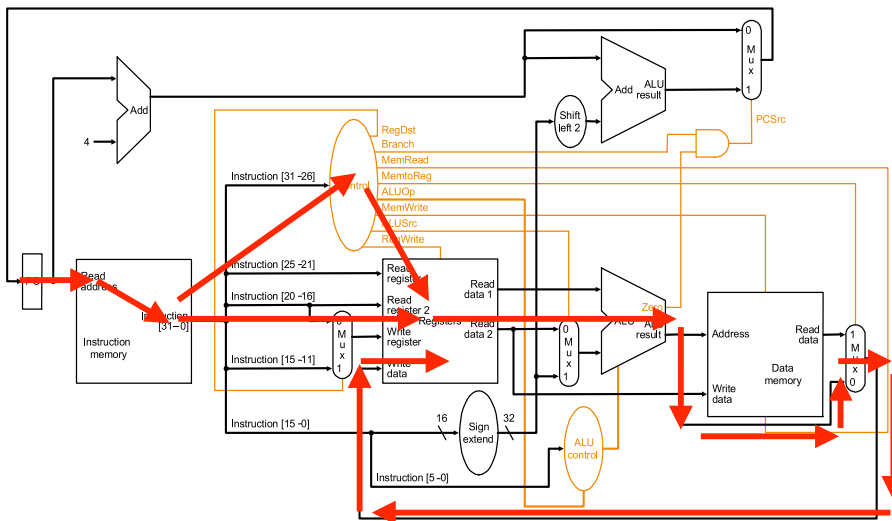

In terms of course work:

- In class and in homework assignments, we look at design issues that relate to modern machines
- In labs, we apply these ideas on a smaller scale (i.e. the 6-instruction processor) and tie lessons learned in the lab back to class work
- Before we talk more about MIPS, let's spend a few slides thinking about how this fits into the big picture.

Back to course goals...

- At the end of the semester, you should be able to...
 - ...describe the fundamental components required in a single core of a modern microprocessor
 - ~~(Also, explain how they interact with each other, with main memory, and with external storage media...)~~

Example

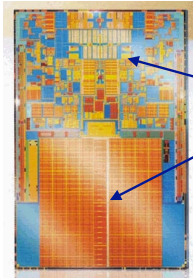

How do on-chip memory, processor logic, main memory, disk interact?

2.0 GB

\$200.00

Apple Memory Module 2GB
667MHz DDR2 (PC2-5300)
2x 1GB SO-DIMMs
Estimated Ship: Within 24 hours
Free Shipping

750GB SATA Hard Disk Drive Kit for...
Ships: Within 24hrs
Free Shipping
★★★★★
\$299.00

Back to course goals...

- At the end of the semester, you should be able to...
 - ...understand how code written in a high-level language (e.g. C) is eventually executed on-chip...

Example

In C:

```
void insertionSort(int numbers[], int array_size)
{
    int i, j, index;
    for (i=1; i < array_size; i++)
    {
        index = numbers[i];
        j = i;
        while ((j > 0) && (numbers[j-1] > index))
        {
            numbers[j] = numbers[j-1];
            j = j - 1;
        }
        numbers[j] = index;
    }
}
```

See chalk board.

In Java:

```
public static void insertionSort(int[] list, int length) {
    int firstOutOfOrder, location, temp;

    for (firstOutOfOrder = 1; firstOutOfOrder < length; firstOutOfOrder++) {
        if (list[firstOutOfOrder] < list[firstOutOfOrder - 1]) {
            temp = list[firstOutOfOrder];
            location = firstOutOfOrder;

            do {
                list[location] = list[location-1];
                location--;
            } while (location > 0 && list[location-1] > temp);

            list[location] = temp;
        }
    }
}
```

Both programs could be run on the same processor... how does this happen?

That said...

A reason today's compilers work like this:

Dependencies:

- Language dependent
- Machine independent
- Somewhat language dependent
- Largely machine independent
- Small language dependencies
- Machine dependencies slight
- (I.e. register counts/types)
- Highly machine dependent
- Language independent

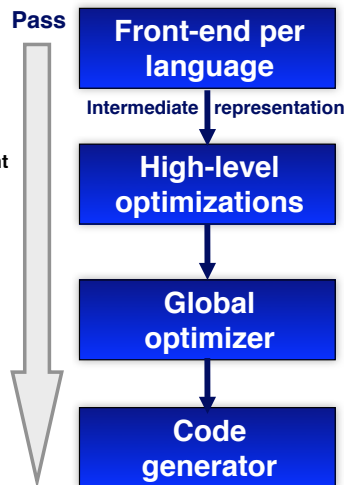

Function:

- Transform language to common, intermediate form
- For example, procedure inlining and loop transformations
- Including global and local optimization + register allocation
- Detailed instruction selection and machine-dependent optimizations (assembler next?)

We'll discuss MIPS more in a bit...
...but 1st, a few slides on ISAs in general.

Instructions Sets

- “Instruction set architecture is the structure of a computer that a machine language programmer (or a compiler) must understand to write a correct (timing independent) program for that machine”
 - IBM introducing 360 (1964)
- an instruction set specifies a processor’s functionality
 - what operations it supports
 - what storage mechanisms it has & how they are accessed
 - how the programmer/compiler communicates programs to processor

ISA = “interface” between HLL and HW

...

ISAs may have different syntax (6-instruction vs. MIPS), but can still support the same general types of operations (i.e. Reg-Reg)

Instruction Set Architecture

- Must have instructions that
 - Access memory (read and write)
 - Perform ALU operations (add, multiply, etc.)
 - Implement control flow (jump, branch, etc.)
 - I.e. to take you back to the beginning of a loop
- Largest difference is in accessing memory
 - Operand location
 - (stack, memory, register)
 - Addressing modes
 - (computing memory addresses)
 - (Let’s digress on the board and preview how MIPS does a load)
 - (Compare to 6-instruction processor?)

What makes a good instruction set

- implementability
 - supports a (performance/cost) range of implementations
 - implies support for high performance implementations
- **programmability** A bit more on this one...
 - easy to express programs (for human and/or compiler)
- backward/forward compatibility
 - implementability & programmability across generations
 - e.g., x86 generations: 8086, 286, 386, 486, Pentium, Pentium II, Pentium III, Pentium 4...
- think about these issues as we discuss aspects of ISAs

Programmability

- a history of programmability
 - pre - 1975: most code was hand-assembled
 - 1975 – 1985: most code was compiled
 - but people thought that hand-assembled code was superior
 - 1985 – present: most code was compiled
 - and compiled code was at least as good as hand-assembly

over time, a big shift in what
“programmability” means

Today's Semantic Gap

- popular argument: today's ISAs are targeted to one HLL, and it just so happens that this HLL (C) is very low-level (assembly++)
 - i.e. $i = j + k$; vs. Add Ri, Rj, Rk
- would ISAs be different if Java was dominant?
 - more object oriented?
 - support for garbage collection (GC)?
 - support for bounds-checking?
 - security support?

Instruction Set Aspects

- #1 format
 - length, encoding
- #2 operations
 - operations, data types, number & kind of operands
- #3 storage
 - internal: accumulator, stack, general-purpose register
 - memory: address size, addressing modes, alignments
- #4 control
 - branch conditions, special support for procedures, predication

Aspect #1: Instruction Format

- fixed length (most common: 32-bits)
 - (plus) easy for pipelining (e.g. overlap) and for multiple issue (superscalar)
 - don't have to decode current instruction to find next instruction
 - (minus) not compact
 - Does the MIPS add "waste" bits?
- variable length
 - (plus) more compact
 - (minus) hard (but do-able) to superscalarize/pipeline
 - $PC = PC + ???$

Variable Addressing Mode

- **Variable addressing mode** – allows virtually all addressing modes with all operations
 - Best when many addressing modes & operations



i.e. register-memory, memory-memory,
register-register... all possible

Some random comments

- **Variable addressing mode** – allows virtually all addressing modes with all operations
 - Best when many addressing modes & operations

i.e. register-memory, memory-memory, register-register...

- **Fixed addressing mode** – combines operation & addressing mode into opcode
 - Best when few addressing modes and operations
 - Good for RISC

What's RISC? "Primitives not solutions." **This is us.**



Some random comments

- **Variable addressing mode** – allows virtually all addressing modes with all operations
 - Best when many addressing modes & operations

- **Fixed addressing mode** – combines operation & addressing mode into opcode
 - Best when few addressing modes and operations
 - Good for RISC

What's RISC? "Primitives not solutions." **This is us.**

- **Hybrid approach is 3rd alternative**

- Usually need a separate address specifier per operand

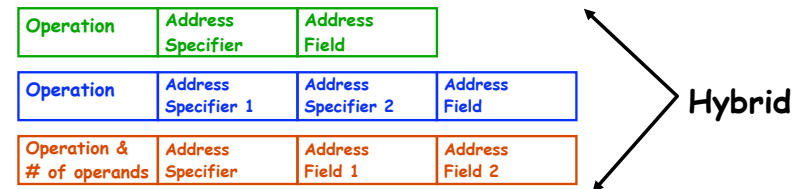

Aspect #2: Operations

- arithmetic and logical:
 - add, mult, and, or, xor, not
- data transfer:
 - move, load, store
- control:
 - conditional branch, jump, call, return
- system:
 - syscall, traps
- floating point:
 - add, mul, div, sqrt
- decimal:
 - addd, convert (not common today)
- string:
 - move, compare (also not common today)
- multimedia:
 - e.g., Intel MMX/SSE and Sun VIS
- vector:
 - arithmetic/data transfer, but on vectors of data

If no instruction for HLL operation, can "fake it" -- i.e. lots of adds instead of multiply.

Examples...

Data Sizes and Types

- fixed point (integer) data
 - 8-bit (byte), 16-bit (half), 32-bit (word), 64-bit (double)
- floating point data
 - 32/64 bit (IEEE754 single/double precision)
 - 80-bit (Intel proprietary)
- address size (aka "machine size")
 - e.g., 32-bit machine means addresses are 32-bits
 - virtual memory size key: 32-bits → 4GB (not enough)
 - famous lesson:
 - one of the few big mistakes in an architecture is not enabling a large enough address space

Aspect #3: Internal Storage Model

- choices
 - stack
 - accumulator
 - memory-memory
 - register-memory
 - register-register (also called “load/store”)
- running example:
 - add C, A, B (C := A + B)

Also this evolution b/c of evolution in HW complexity

Storage Model: Stack

```
push A  S[++TOS] = M[A];
push B  S[++TOS] = M[B];
add     T1=S[TOS--]; T2=S[TOS--]; S[++TOS]=T1+T2;
pop C   M[C] = S[TOS--];
```

- operands implicitly on top-of-stack (TOS)
- ALU operations have zero explicit operands
 - (plus) code density (top of stack implicit)
 - (minus) memory, pipelining bottlenecks (why?)
- mostly 1960's & 70's
 - x86 uses stack model for FP
 - (bad backward compatibility problem)
 - JAVA bytecodes also use stack model

Storage Model: Accumulator

```
load A  accum = M[A];
add B   accum += M[B];
store C M[C] = accum;
```

- acc is implicit destination/source in all instructions
- ALU operations have one operand
 - (plus) less hardware, better code density (acc implicit)
 - (minus) memory bottleneck
- mostly pre-1960's
 - examples: UNIVAC, CRAY
 - x86 (IA32) uses extended accumulator for integer code

Storage Model: Memory-Memory

```
add C,A,B  M[C] = M[A] + M[B];
```

- no registers
 - (plus) best code density (most compact)
 - Why? Total # of instructions smaller for one...
 - (minus) large variations in instruction lengths
 - (minus) large variations in work per-instruction
 - (minus) memory bottleneck
- no current machines support memory-memory

Storage Model: Memory-Register

```
load R1,A    R1 = M[A];
add R1,B     R1 = R1 + M[B];
store C,R1   M[C] = R1;
```

- like an explicit (extended) accumulator
 - (plus) can have several accumulators at a time
 - (plus) good code density, easy to decode instructions
- asymmetric operands, asymmetric work per instruction
- 70's and early 80's
 - IBM 360/370
 - Intel x86, Motorola 68K

Storage Model: Register-Register (Ld/St)

```
load R1,A    R1 = M[A];
load R2,B    R2 = M[B];
add R3,R1,R2 R3 = R1 + R2;
store C,R3   M[C] = R3;
```

- load/store architecture: ALU operations on regs only
 - (minus) poor code density
 - (plus) easy decoding, operand symmetry
 - (plus) deterministic length ALU operations
 - (plus) fast decoding helps pipelining and superscalar
- 1960's and onwards
 - RISC machines: Alpha, MIPS, PowerPC (but also Cray)

On to MIPS

- MIPS is a register-register machine
- Aside from enhancements we made, 6-instruction is too!

MIPS Registers (R2000/R3000)

32x32-bit GPRs (General purpose registers)

- \$0 = \$zero (therefore only 31 GPRs)
- \$1 = \$at (reserved for assembler)
- \$2 - \$3 = \$v0 - \$v1 (return values)
- \$4 - \$7 = \$a0 - \$a3 (arguments)
- \$8 - \$15 = \$t0 - \$t7 (temporaries)
- \$16 - \$23 = \$s0 - \$s7 (saved)
- \$24 - \$25 = \$t8 - \$t9 (more temporaries)
- \$26 - \$27 = \$k0 - \$k1 (reserved for OS)
- \$28 = \$gp (global pointer)
- \$29 = \$sp (stack pointer)
- \$30 = \$fp (frame pointer)
- \$31 = \$ra (return address)

- 32x32-bit floating point registers (paired double precision)
- HI, LO, PC
- Status, Cause, BadVAddr, EPC

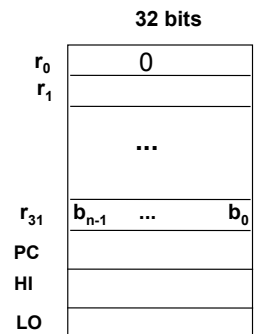

Board digression

- Programmer visibility
- Procedure calls

Memory Organization

□ Addressable unit:

- smallest number of consecutive bits (word length) can be accessed in a single operation
- Example, $n=8$, byte addressable

Given 1K bit memory, 16 bit word addressable:

How many words?

How many address bits?

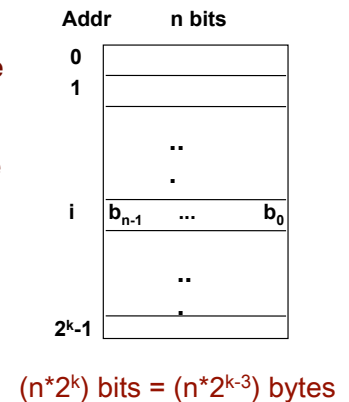

MIPS uses byte-addressable memory

Effect of Byte Addressing

MIPS: Most data items are contained in *words*, a word is 32 bits or 4 bytes. *Registers hold 32 bits of data*

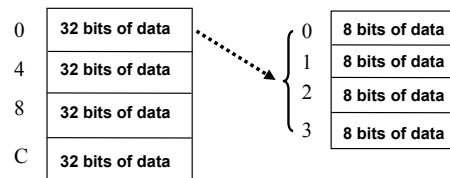

- 2^{32} bytes with byte addresses from 0 to $2^{32}-1$
- 2^{30} words with byte addresses 0, 4, 8, ... $2^{32}-4$
- Words are aligned
- What are the least 2 significant bits of a word address?

A View from 10 Feet Above

- Instructions are characterized into basic types
- Each type interpret a 32-bit instruction differently
- 3 types of instructions:
 - R type
 - I type
 - J type
- Look at both assembly and machine code
- In other words:
 - As seen with Add, instruction encoding broken down into X different fields
 - With MIPS, only 3 ways X # of bits arranged
 - Think about datapath: Why might this be good?

R-Type: Assembly and Machine Format

- R-type: All operands are in registers

Assembly: `add $9, $7, $8` # add rd, rs, rt: $RF[rd] = RF[rs] + RF[rt]$

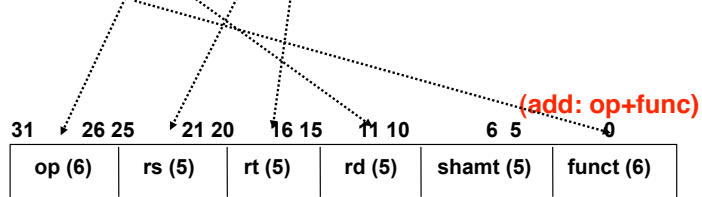

Machine:

B: 000000 00111 01000 01001 xxxxx 100000
 D: 0 7 8 9 x 32

R-type Instructions

- All instructions have 3 operands
- All operands must be registers
- Operand order is fixed (destination first)
- Example:

C code: `A = B - C;`

(Assume that A, B, C are stored in registers s0, s1, s2.)

MIPS code: `sub $s0, $s1, $s2`

Machine code:

- Other R-type instructions

- addu, mult, and, or, sll, srl, ...

I-Type Instructions

- I-type: One operand is an immediate value and others are in registers

Example: `addi $s2, $s1, 128` # addi rt, rs, Imm
 # $RF[18] = RF[17] + 128$

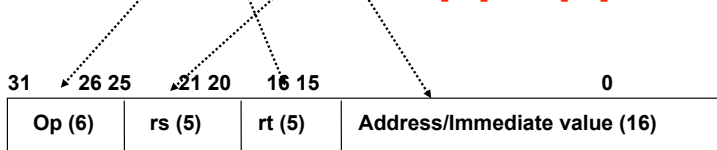

B: 001000 10001 10010 0000000010000000
 D: 8 17 18 128

I-Type Instructions: Another Example

- I-type: One operand is an immediate value and others are in registers

Example: `lw $s3, 32($t0)` # $RF[19] = DM[RF[8] + 32]$

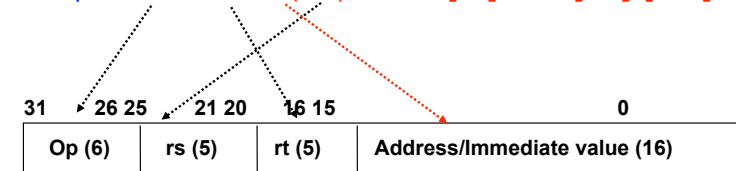

B: 100011 01000 10011 0000000000100000
 D: 35 8 19 32

How about load the next word in memory?

I-Type Instructions: Yet Another Example

- I-type: One operand is an immediate value and others are in registers

Example: Again:: `bne $t0, $t1, Again`

if (RF[8]!=RF[9]) PC=PC+4+Imm*4

else PC=PC+4 (Why "4"?)

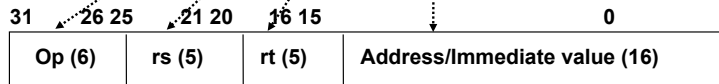

B: 00101 01000 01001 1111111111111111
 D: 5 8 9 -1

PC-relative addressing

J-Type Instructions

- J-type: only one operand: the target address

Example: `j 3` # PC = (PC+4)[31:28]||Target||00 (Why "00"?)



B: 000010 0000000000000000000000000011
 D: 2 3

Pseudo-direct Addressing

Example: Memory Access Instructions

- MIPS is a Load/Store Architecture (a hallmark of RISC)
 - Only load/store type instructions can access memory
- Example: `A = B + C;`
 - Assume: A, B, C are stored in memory, \$s2, \$s3, and \$s4 contain the addresses of A, B and C, respectively.
 - `lw $t0, 0($s3)`
 - RF[8]=DM[RF[19]]
 - `lw $t1, 0($s4)`
 - RF[9]=DM[RF[20]]
 - `add $t2, $t0, $t1`
 - # RF[10]=RF[8]+RF[9]
 - `sw $t2, 0($s2)`
 - DM[RF[18]]=RF[10]
- `sw` has destination last
- What is the instruction type of `sw`?

See handout for lots of examples.