

THE NATIONAL EXAMINATIONS COUNCIL OF TANZANIA

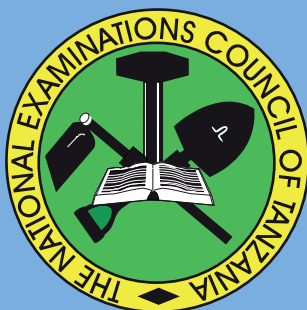

**STUDENTS' ITEMS RESPONSE ANALYSIS
REPORT FOR THE FORM TWO NATIONAL
ASSESSMENT (FTNA) 2018**

070 TECHNICAL DRAWING

THE NATIONAL EXAMINATIONS COUNCIL OF TANZANIA

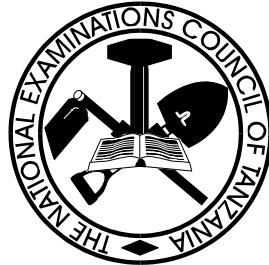

**STUDENTS' ITEMS RESPONSE ANALYSIS
REPORT FOR THE FORM TWO NATIONAL
ASSESSMENT (FTNA) 2018**

070 TECHNICAL DRAWING

Published by
National Examinations Council of Tanzania,
P.O. Box 2624,
Dar as salaam, Tanzania

© The National Examinations Council of Tanzania, 2019

All rights reserved.

TABLE OF CONTENTS

FOREWORD	iv
1.0 INTRODUCTION.....	1
2.0 ANALYSIS OF INDIVIDUAL QUESTIONS	2
2.1 SECTION A: COMPULSORY PART	2
2.1.1 Question1. Multiple Choice Items (various topics).....	2
2.1.2 Question 2. True or False	12
2.1.3 Question 3: Geometrical Construction in Plane Geometry	17
2.1.4 Question 4. Loci	19
2.2 SECTION B: SELECTION OF TWO QUESTIONS	23
2.2.1 Question 5: Auxiliary Views	23
2.2.2 Question 6: Pictorial Drawing	27
2.2.3 Question 7. Orthographic Projection	30
3.0 CONCLUSION	34
4.0 RECOMMENDATIONS	35
4.1 Syllabus Covered	35
4.2 Technical Professional Personnel	35
<i>Appendix I</i>	36
<i>Appendix II</i>	37
<i>Appendix III</i>	38
<i>Appendix IV</i>	39

FOREWORD

The Students Items Response Analysis report for the Form Two National Assessment (FTNA) 2018 in Technical Drawing subject was prepared in order to provide feedback to students, parents, policy makers and the public in general on the students' performance.

The Form Two National Assessment is a two-year formative evaluation which, among other things, shows the effectiveness of education system in general and education delivery system in particular. Essentially, students responses to the assessment questions is a strong indicator of what the education system was able or unable to offer to students in their two years of secondary education.

This booklet presents the analysis intended to contribute towards understanding some of the reasons affecting good performance of students in the Technical Drawing subject. The report highlights some of the factors that made some students to score high or low marks in the respective questions. The factors which made the students to perform well include their ability to answer the questions according to the demands of the questions as well as their knowledge in the subject matter. However, there are factors which effect some of the students to score high marks. Such factors include lack of knowledge in relation to a particular concept, failure to interpret the demands of the questions, poor English Language command and inability to answer questions which demand the application of knowledge and skill in performing design, sketching and drawing various machine components .

The feedback provided will enable the educational administrators, school managers, teachers and students to identify proper measures to be taken to improve students' performance in future. The National Examinations Council of Tanzania (NECTA) will highly appreciate comments and suggestions from teachers, students and the public in general that can be used in improving feedback reports.

Finally, the Council would like to thank the assessors and all those who participated in preparing and analysing the data used in this report as well as in typesetting the document.



Dr Charles E. Msonde
EXECUTIVE SECRETARY

1.0 INTRODUCTION

This report provides in detail the analysis of the performance for the students in Technical Drawing examination of Form Two National Assessment (FTNA) in the year 2018. The examination covered the syllabus of the secondary Education issued in 1994 and it was set in accordance with the examination format.

A total of 1485 students sat for the technical drawing subject for the year 2018, out of which 238 (16.03%) students passed and 1247 (83.97%) failed. In 2017, a total of 1269 students sat for the assessment in which 100 (7.88%) students passed while the remaining 1169 (92.12%) students failed. This indicates that there is an increase of 8.15 percent of students who passed the examination in 2018 compared to the 2017.

Technical drawing paper had seven (7) questions divided in sections A and B. Students were required to answer all questions in section A and two (2) questions from section B.

The performance of students in this analysis is categorised in the ranges of from 0 to 29 percent as unsatisfactory, 30 to 64 percent as average and 65 to 100 percent as a good. Table 1 and Figure 1 show overall performance of 1,485 students who sat for Technical Drawing Examination in 2018 FTNA.

Table1. General students' performance in Technical Drawing Subject

Grade Ranges	Percentage Range	Remarks	Number of Students
0 -29	0% -29%	Unsatisfactory	1,244
30- 64	30% - 64%	Average	210
65 - 100	65% - 100%	Good	31

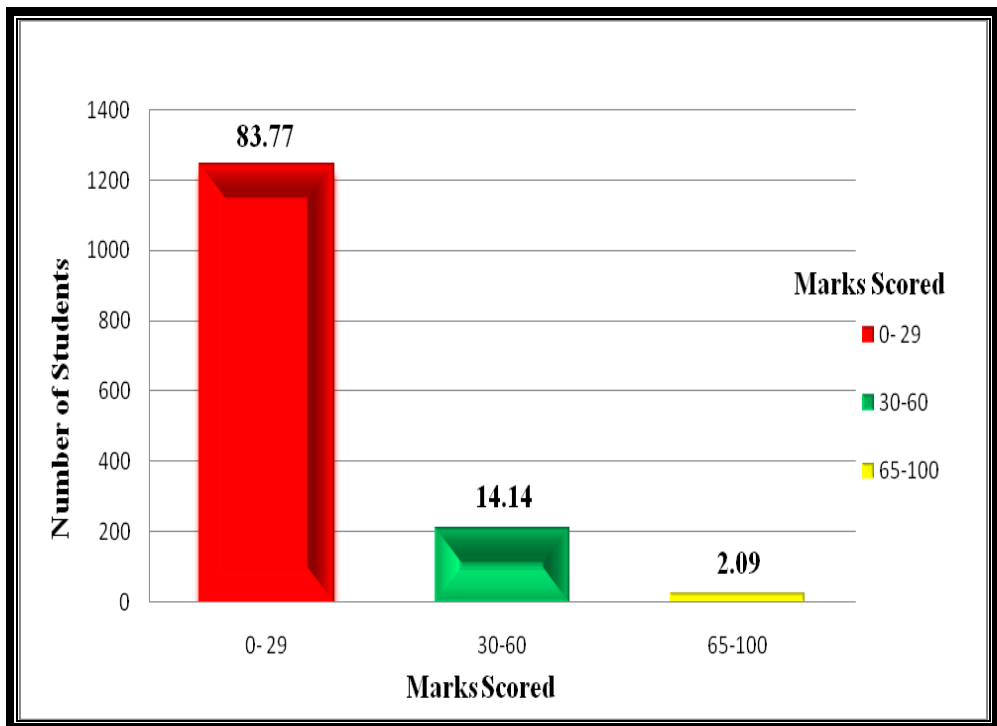

Figure 1: the general students' performance in Technical Drawing

2.0 ANALYSIS OF INDIVIDUAL QUESTIONS

2.1 SECTION A: COMPULSORY PART

Section A comprised of four (4) questions and had a total of forty (40) marks. Students were required to answer all questions in this section.

2.1.1 Question1. Multiple Choice Items (various topics)

The question comprised of ten (10) items (i) – (x), which were set from various topics in the syllabus. Students were required to choose the correct answer from the four given alternatives for each item.

The question was attempted by 1485 (100%) students, out of which 29 percent scored from 0 to 2.9 marks, 66.7 percent scored from 3 to 6.4 marks and 5.3 percent scored from 6.5 to 10 marks. Five (5) (0.30%) students performed very well by scoring 9 marks out of 10 marks. The rest of the performance are as presented in Table 2.

Table 2: The trend of students' performance in Question 1

Grade Ranges	Percentage Range	Description	Students	
			Number	Percentage
0-2.5	0-29	Satisfactory	430	29
3-6.0	30-64	Average	977	66
6.5-10	65-100	Good	78	5
TOTAL			1485	100

The overall performance of the students in this question was good, because 71.04 percent of them scored from 30 percent and above (3-10 marks). This performance suggests that most of the students were able to identify the correct answer from the given alternatives in at least two or more items in the question. On the other hand there were some students who could not make correct choices of the right answer in most of the items as illustrated in Figure 2.

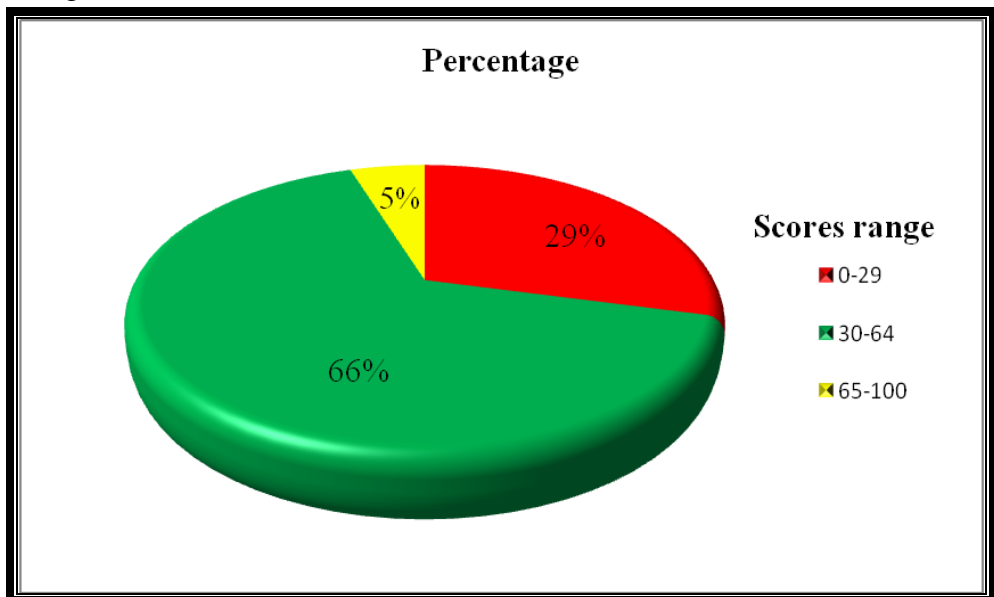
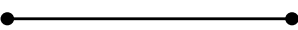

Figure 2: students' performance in percentage for Question 1

ANALYSIS OF THE ITEM

In item (i), the students were required to identify the uses of different types of line. Students were required to apply the knowledge of convention used in technical drawing to answer the question. The question was:

(i) *Which of the following line is used for dimensioning in technical drawing?*

A 

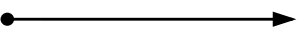
B 

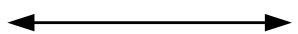
C 

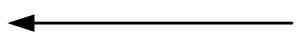
D 

The correct answer was C. This was opted by students who had knowledge of types of lines. Those who failed to choose the correct answer could not distinguish between the dimension lines and direction lines. The dimension lines have arrowheads which are placed on both ends of the lines. The aim of these type of line is to show the size of the part while the direction lines has arrowheads at only one side and uses to indicate the component or part of the component. Moreover, alternatives B and D are directional lines which are used in Technical Drawing to show the specific item.

Item (ii) tested the students' ability to demonstrate different types of lines. In this item, students were supposed to identify the relation between the height of the letter and the horizontal guidelines. The question was:

(ii) *Horizontal guidelines are always used to get:*

A *a uniform height for numeral*

B *a uniform height for numbers*

C *a uniform height for style*

D *a uniform height of letter*

The correct answer was D: *a uniform height of letters*. Those who opted for A: *a uniform height for numerals*, B: *uniform height for numbers* and C: *uniform height for style* lacked the knowledge on letter writing and application of guideline in lettering during drawing. In technical drawing

the letters are required to be written in freehand, therefore to maintain the height and style the guide lines are used, while the numeral and symbols may be allowed to use drawing instruments such as drawing template.

Item (iii) demanded the students to identify the application of accurate papers which are normally used for sketching. There are various types of papers used in technical drawing; these can be distinguished by size and types. The question was:

(iii) Which type of paper is commonly used for sketching accurately?

A Ruled paper

B Plain paper

C Graph paper

D A4 size paper

The correct answer was B: *Plain paper*. Students who opt for A: *Ruled paper* and C: *Graph paper* failed to differentiate the type of paper used for sketching and the one which are used for normal writing. Also those who opted for D: *A4 size paper* failed to distinguish between size of paper and types of paper used for sketching in Technical Drawing.

Item (iv) tested the students' knowledge on the rules of dimensioning of different figures. The students were required to show which is written first when dimensioning the circle in Technical Drawing. The question was:

(iv) The dimensioning of a circle on technical drawing must be preceded by:

A a number

B a letter

C a point

D a line

The correct answer is B: *a letter*. Those who opted for A: *a number* lacked knowledge of dimensioning circle and other geometric figures. In dimensioning circle, the first digit required to start is a letter a or symbol (can be symbol R as radius or symbol ϕ as diameter) then followed by number. However, some students opted for C: *a point* and D: *a line* knowing that in drawing any figure, we start with point or lines.

Item (v) required the students' to explain the importance of knowing the starting point in drawing of a locus when it moves in the path plotted by

that point. The question measured the ability of students in plotting the locus. The question was:

(v) *Why is it important to know the position of the given point and condition of movement when drawing locus?*

- A In order to identify the starting position and trace the path of locus*
- B In order to trace the position of path of locus upward and downward*
- C In order to use position of point and scaled ruler to trace the path of locus*
- D In order to use compass and starting position to trace the path of locus*

The correct answer was A: *In order to identify the starting position and trace the path of the locus*. Students who chose the correct answer had the knowledge and skill in loci mechanism drawing. However, students who chose B: *In order to trace the position of path of locus upward and downward* confused with the methods used to trace the locus. In drawing the locus, the methods used is to trace path, not the position of the path. Students who opted for C: lacked the knowledge of application of scaled ruler. It is not used for tracing locus students who opted for D: *In order to use compass and starting position to trace the path of locus*, lacked the knowledge of using the compass and point in drawing the locus. The compass is the tool used to draw circle and arc but it is not used for tracing.

Item (vi) demanded the students to list down two common types of drawing shapes of the scale. The aim of this question was to measure the understanding of the students in shapes of scale which are commonly used in drawing. The question was:

(vi) *The two common types of drawing scales shapes are:*

- A triangular and curved* *B flat and rough*
- C triangular and vertical* *D triangular and flat*

The correct alternative is D: *Triangular and flat*. Scale is the abbreviation which is used by the engineer in representing the actual object in drawing sheet. It may be reduced or enlarged depending on the needs. In

representing an object *Triangular and flat* are common types of shape which are applicable to all standardised drawing. Students who opted for A: *Triangular and curved* and C: *Triangular and vertical* misinterpreted between types, shape and style of drawing scale. Vertical and curved are styles of drawing scale. Moreover students who opted for B: *flat and rough* did not have common understanding of the scale and its application as well as type and shape as applied in technical drawing.

Item (vii) tested the students' ability to identify how equal is a plane figure considering angles and sides. The aim of this question was to measure the students' understanding in geometrical and plane figures so as to build their awareness in manufacturing and fabrication of the components. The question was:

(vii) *A plane figure with four sides having equal sides and equal opposite angle is called:*

A *Rhombus*
C *Trapezium*

B *Rhomboid*
D *Quadrilateral*

The correct answer was A: *Rhombus*. Students who opted for this answer had knowledge of types quadrilateral geometrical figure (*Rhombus*) having two same angle and four equal side and length. Those who opted for B: *Rhomboid* confused between the two words *Rhomboid* which is a parallelogram in which adjacent side are unequal while *Rhombus* is equilateral quadrilateral figure. However, some students who chose C: *trapezium* and D: *Quadrilateral* lacked knowledge of differentiating between the figures having two sides parallel and four figures with different sides thus *Trapezium is a quadrilateral with one pair of sides parallel* and *Quadrilateral is a polygon with four sides*.

Item (viii) required the students to apply knowledge of technical drawing to emphasize the convention of three dimension views to two dimension views in the paper. The question was:

(viii) *In orthographic projection sphere object are presented by:*

A *three views*
C *four views*

B *one view*
D *two views*

The correct answer was B: *one view*. Students who opted for this answer had knowledge of the shape of a sphere. That sphere is the perfect round object in three dimensional spaces that is the surface of a completely round ball. So when viewing front, top or side, the shape and dimension are the same. Those who opted for A: *Rhomboid* and D: *two views* confused between the three dimensions and two dimensional views. In pictorial drawing; the plan, front and sides views are seen in one object, where by height, length and width are indicated. Meanwhile if front, end (side) or plan views are shown in separately this object is known as orthographic drawing. In orthographic drawing only two dimensions can be shown. These can be length and height (Front view), length and width (Plan view) or Width and height (Side or End view). However, some students who choose C: *four views* lacked knowledge of the shape of a sphere whereby when looking on top or front or side, the shape are the similar.

Item (ix) tested students' ability of analysing dimension and size of drawing sheet used in Technical Drawing Subject. The question was:

(ix) *In standard ISO and drawing sheet in Technical Drawing, A₁ contains:*

A *two A₃*

B *three A₃*

C *four A₃*

D *five A₃*

The correct answer is C: *four A₃*. This question required the students to identify different types of paper sizes in Technical Drawing subject with reference to standard ISO and drawing sheet. The students who chose this answer were familiar with the convention of sheet and its size. Those who chose A: *two A₃* lacked the understanding size of the sheet and its measurements. According to ISO, the dimension of sheet decreases as the number increases. Example A₀ is the twice as much as A₁, A₁ is twice as much as A₂, A₂ is twice as much as A₃Therefore those students who chose B: *three A₃* and D: *five A₃* lacked this concept of paper sizes and their relation.

Item (x) tested the students' ability of understanding common types of pictorial views in Technical Drawing Subject. The question was:

(x) *The two common types of pictorial presentation in drawing are:*

- A Isometric and Oblique drawing*
- B Orthographic and Oblique drawing*
- C Auxiliary and Orthographic drawing*
- D Orthographic and Isometric drawing*

The correct answer was A: *Isometric and Oblique drawing*. The question required the students to identify different types of three dimensional view (Pictorial view). Those students who opted B: *Orthographic and Oblique drawing* and D: *Orthographic and Isometric drawing* could not differentiate between two dimensional and three dimensional views. Isometric and Oblique views are three dimensional views whereby height, width and length are indicated in one drawing, while orthographic is two dimensional views where by object can show length and height, width and length or width and height. Furthermore, students who opted C: *Auxiliary and Orthographic drawing* lacked knowledge that auxiliary is the pictorial drawing whereby three views and dimensions can be seen in one object but differ in angle and nature of drawing with Isometric and Oblique. Extract 1.1 and 1.2 shows a sample of a poor and good response of question 1.

1. For each of the following items (i) – (x), choose the correct answer from among the given alternatives and write its letter in the box provided.

(i) Which of the following line is used for dimensioning in technical drawing?



A

(ii) Horizontal guide lines are always used to get

A a uniform height for numerals. B a uniform height for numbers.
C a uniform height for style. D a uniform height of letters.

D

(iii) Which type of paper are commonly used for sketching accurately?

A Ruled paper B Plain paper
C Graph paper D A4 size paper.

D

(iv) The dimensioning of a circle on Technical Drawing must be preceded by

A a number. B a letter. C a point. D a line.

D

(v) Why is it important to know the position of the given point and condition of movement when drawing locus?

A In order to identify the starting position and trace the path of locus
B In order to trace the position of path of locus upward and downward
C In order to use position of point and scaled ruler to trace the path of locus
D In order to use compass and starting position to trace the path of locus

A

(vi) The two common types of drawing scales shapes are

A triangular and curved. B flat and rough.
C triangular and vertical. D triangular and flat.

B

(vii) A plane figure with four sides having equal sides and equal opposite angle is called

A Rhombus B Rhomboid
C Trapezium D Quadrilateral.

A

(viii) In orthographic projection sphere object are presented by

A three views B one view
C four views D two views.

B

(ix) In Standard ISO and drawing sheet in Technical drawing A₁ contains

A two A₃. B three A₃.
C four A₃. D five A₃.

C

(x) The two common types of pictorial presentation in drawing are

A Isometric and Oblique drawing.
B Orthographic and Oblique drawing.
C Auxiliary and Orthographic drawing.
D Orthographic and Isometric drawing.

A

Extract 1.1: a sample of response from one of the students who managed to answer most of the Question 1 correctly.

1. For each of the following items (i) – (x), choose the correct answer from among the given alternatives and write its letter in the box provided.

(i) Which of the following line is used for dimensioning in technical drawing?

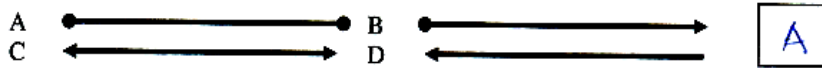

(ii) Horizontal guide lines are always used to get

- A a uniform height for numerals. B a uniform height for numbers.
C a uniform height for style. D a uniform height of letters.

(iii) Which type of paper are commonly used for sketching accurately?

- A Ruled paper B Plain paper
C Graph paper D A4 size paper.

(iv) The dimensioning of a circle on Technical Drawing must be preceded by

- A a number. B a letter. C a point. D a line.

(v) Why is it important to know the position of the given point and condition of movement when drawing locus?

- A In order to identify the starting position and trace the path of locus
B In order to trace the position of path of locus upward and downward
C In order to use position of point and scaled ruler to trace the path of locus
D In order to use compass and starting position to trace the path of locus

(vi) The two common types of drawing scales shapes are

- A triangular and curved. B flat and rough.
C triangular and vertical. D triangular and flat.

(vii) A plane figure with four sides having equal sides and equal opposite angle is called

- A Rhombus B Rhomboid
C Trapezium D Quadrilateral.

(viii) In orthographic projection sphere object are presented by

- A three views B one view
C four views D two views.

(ix) In Standard ISO and drawing sheet in Technical drawing A₁ contains

- A two A₃. B three A₃.
C four A₃. D five A₃.

(x) The two common types of pictorial presentation in drawing are

- A Isometric and Oblique drawing.
B Orthographic and Oblique drawing.
C Auxiliary and Orthographic drawing.
D Orthographic and Isometric drawing.

Extract 1.2: a sample of poor response from one of the students for Question 1.

2.1.2 Question 2. True or False

The question consisted of ten (10) items (i) – (x) whereby students were required to write TRUE if the statement was correct or FALSE if the statement was not correct. This question was compulsory, so all students attempted it. The general performance in this question was good since 97.5 percent of the students scored 30 percent and above (From 3 to 10 marks).

The question was attempted by 1485 Students, out of which 2.5 percent scored from 0 to 2.5 marks which is unsatisfactory, 55.30 percent scored from 3 to 6.0 marks which is average performance and 42.20 percent scored 65 percent and above (From 6.5 to 10 marks) which are good response. Table 3 and Figure 3 represent such performance of the students who attempted this question.

Table 3: Summarised students' scores of for Question 2

Grade Ranges	Percentage Range	Remark	Students	
			Total Number	Percentage
0-2.5	0-29	Unsatisfactory	37	2.5
3.0-6.0	30-64	Average	822	55.3
6.5-10	65-100	Good	626	42.2
TOTAL			1485	100

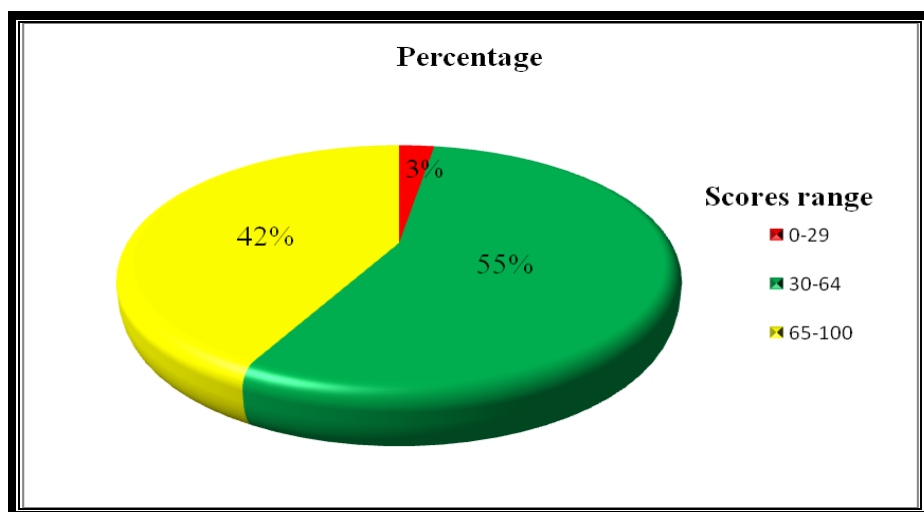

Figure 3: The trend of students' performance in Question 2

ANALYSIS OF THE ITEMS

Item (i) tested the students' understanding of the views drawn in Technical drawing by identifying types of views obtained in Orthographic drawing if it is correct or not. The question was:

(i) Front elevation, plan and side elevation are drawn from orthographic drawing.....

The correct response was FALSE. The students who wrote correct answer they had knowledge on the orthographic projection that is two dimensional views where by object shows length and height (Front view), width and length (Plan view) or width and height (Side view). Some of the students who wrote TRUE confused the orthographic drawing and isometric drawing. They didn't know that front, top and end views together are obtained from the pictorial drawing.

Item (ii) tested the students' ability to apply the knowledge on the construction of equal area for a given polygons. The question asked:

(ii) Square can be constructed equal in area from a rectangle.....

The correct answer was TRUE. The aim of this question was to test the students' skill in constructing various polygons in equal area in a given square. The students who produced correct responses had knowledge and skill on the construction of polygons. While those who wrote FALSE did not have a skills on construction of polygon on a given square.

Item (iii) tested students' ability to understand the term 'bisection' as applied in technical drawing. The question was:

(iii) Bisection of lines means to divide it into four equal parts.....

The correct response was FALSE. Students who wrote correct assertion had knowledge and realized the word '*bisection of lines*' which means division of lines into congruent parts. And those who didn't write the correct answer lacked knowledge of bisection of line as applied in Technical Drawing subject.

Item (iv) tested students' ability on writing a write a letter in Technical Drawing. The aim of this question was to test students' understanding on letter writing. The question was:

(iv) There should be space between the lettering words.....

The correct response was TRUE. The question tested the students' knowledge on the application of writing letter with space when representing some information through words in the drawing. The letter spaces displays better visual effect.

Item (v) demanded the students to identify the sizes of paper in technical drawing.

The question was:

(v) The size 420mm×594mm is A₂ standard sheet.....

The correct response was TRUE. Those students who wrote correct answer had assertion correct had knowledge of size of paper used in Technical Drawing subject. Some of the students who produced incorrect always confused the A₂ paper with other paper size especially A₁ and A₃ paper size. And this confusion of mixing paper size happened because one length of A₁ and A₃ papers share the same dimension with A₂ paper and makes the students to mix correct assertion of the corresponding item.

Item (vi) tested the students' understanding of the meaning of Polygon figures. A polygon figure means closed figures where sides are all line segments and their included sides. The question was:

(vi) The octagon is a polygon figure drawn with seven sides.....

The correct response was FALSE. The octagon is the polygon having eight (8) equal sides. The students who wrote the correct answer had a knowledge of the number of sides obtained on the polygons. Some of students who wrote incorrect answer in this question were confusing the sides of polygons and their correspond names.

Item (ix) tested the students' ability to understand the differences types of ISO scale used in Technical Drawing subjects.

The question was:

(ix) Metric scale as used when drawing are made in both metric and imperial.

The correct answer was FALSE. Those students who select correct answer were aware on the difference between the Imperial and Metric in the scale subject matter. Meanwhile, some student who wrote incorrect answer TRUE, proved failure in recalling the types of scale used in Technical Drawing subject.

Item (x) demanded the students' understanding of freehand sketch in engineering aspect.

The question was:

(x) Engineers use free hand sketch to convey the message for machine design or modification.....

The correct answer for this assertion was TRUE. The students who got the assertion/question correct had enough knowledge on drawing. The students who wrote FALSE did not have knowledge on drawing in the contest of engineering. Extract 2.1 and 2.2 shows a sample of a poor and good response of question 2.

2. For each of the following statements, write **True** if the statement is correct or **False** if the statement is not correct.
- (i) Front elevation, plan and side elevation are drawn from orthographic drawing True
 - (ii) Square figure can be constructed equal in area from a rectangle base True
 - (iii) Bisection of line means to divide it into four equal parts True
 - (iv) There should be space between the lettering of words False
 - (v) The size 420 x 594 mm is an A₂ standard sheet False
 - (vi) Octagon is a polygon figure with seven sides True
 - (vii) Cavalier projection is one of full size pictorial drawing False
 - (viii) The unit measure of the size length should be shown by capital letter True
 - (ix) Metric scales are used when drawing are made in both metric and imperial True
 - (x) Engineers use free hand sketch to convey the message for machine design or modification false

Extract 2.1: a sample of poor response by the student who answered Question 2 incorrectly.

2. For each of the following statements, write **True** if the statement is correct or **False** if the statement is not correct.
- (i) Front elevation, plan and side elevation are drawn from orthographic drawing False
 - (ii) Square figure can be constructed equal in area from a rectangle base True
 - (iii) Bisection of line means to divide it into four equal parts False
 - (iv) There should be space between the lettering of words True
 - (v) The size 420 x 594 mm is an A₂ standard sheet True
 - (vi) Octagon is a polygon figure with seven sides False
 - (vii) Cavalier projection is one of full size pictorial drawing True
 - (viii) The unit measure of the size length should be shown by capital letter False
 - (ix) Metric scales are used when drawing are made in both metric and imperial False
 - (x) Engineers use free hand sketch to convey the message for machine design or modification True

Extract 2.2: a sample of response from one of the student who managed to answer all parts of the Question 2 correctly.

2.1.3 Question 3: Geometrical Construction in Plane Geometry

A total of 1390 (93.6%) students attempted this question. 99.3 percent of the students scored from 0 to 2.5 marks, and 0.7 percent scored from 03 to 6.0 marks. The students who didn't attempt the question was 6.4 percent.

Moreover, students' performance of for this question was very poor. The overall highest score was 3 out of ten (10) marks. Most of students failed to understand the demand of the question; hence they provided answers which do not relate to the question.

The question required students to draw a circle which is tangent to line AK though point P and touches the given circle. Those who failed to draw were lacked knowledge of drawing tangential circle with a given line. They failed to know how to draw locus with a given circle at a trajectory points of path. For example some of the students draw an Archimedean Spiral and others draw an Involute of circles which implies that they mixed both topics of Loci and Plane Geometry. The summary of students' scores in this question is presented in Table 4.

Table 4: A summarised groups of scores in terms of percentage of students Question 3

Marks scored	Percentage Range	Remark	Students	
			Total Number	Percentage
0-2.5	0-29	Unsatisfactory	1383	99.3
3.0-6.0	30-64	Average	7	0.7
6.5-10	65-100	Good	0	0
TOTAL			1485	100

Some students failed to use the correct procedures to construct a tangent when given a point. In this question, the students were required to specify the method of drawing a tangent which touches one circle through the given point. Students were unable to attempt this question correctly due to lack of knowledge and confusion with other methods of drawing a tangent.

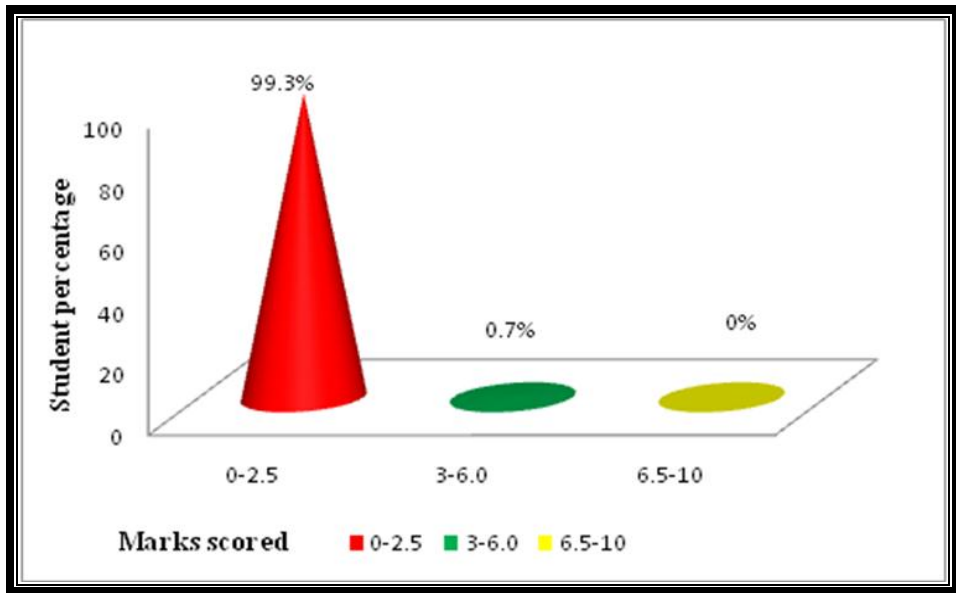
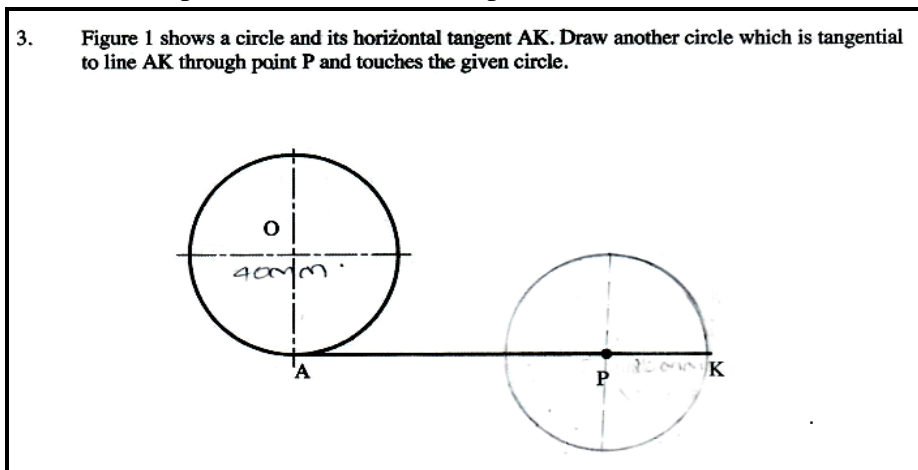

Figure 4: A summarised graph presents the range of scores with in terms of percentage of students who did the Question 3.

The analysis shows that the students failed to differentiate various methods of constructing a tangent in technical drawing. They lacked knowledge on how to mark construction lines which helps them through a given point which touches the circumference of the first circle to get the center of second circle. Extract 3.1 shows a sample of poor response by a student who failed to produce the relevant response in Question 3.



Extract 3.1: a sample of response by student who attempted Question 3 but failed to produce a correct answer.

Some of the students (0.67%) had average score that is 3 and 6.5 marks. This makes the performance of the question to be averagely. No students scored above 6.5 marks. The students who scored 0 marks lacked knowledge and skills on how to construct a tangent to the given point and circle. Extract 3.2 presents an answer by a student who performed Question 3 well.

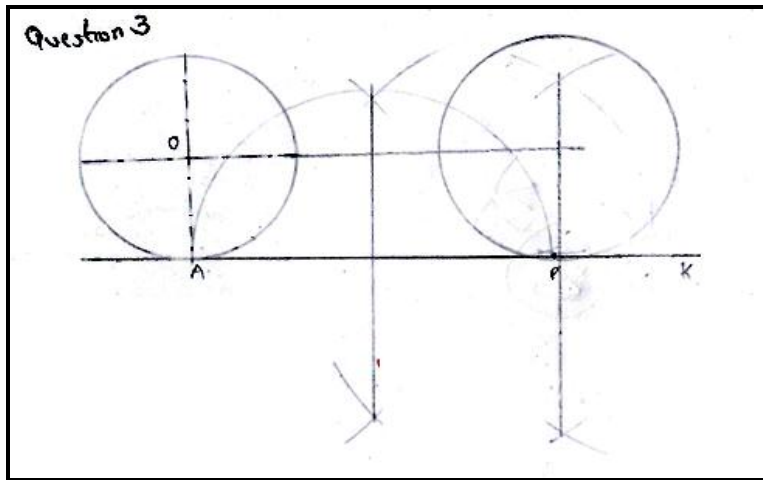

Extract 3.2: a good performance by one of the students who was able to draw correct diagrams.

2.1.4 Question 4. Loci

This question was attempted by 1129 students out of 1485 which is equal to 76 percent. 87.6 percent of students scored from 0-2.5 marks, while 9.0 percent of the students scored from 3 to 6.0 marks and 3.4 percent of the students scored from 6.5 to 10 marks. The percent of the students who didn't attempt the question was 24, which is equal to 356 students.

General performance of the students for this question was poor, as most of the students failed to understand the need of the question. The students required to construct a loci mechanism of the circle with radius ON which rolls without sliding along straight line AB starting from point A.

The table 5 presents summarised percentage groups of scores with respect to percentage of students who did the question.

Table 5: A trend of Students performance in question 4.

Marks Scored	Percentage Range	Description	Candidates	
			Total Number	Percentage
0-2.5	0-29	Unsatisfactory	989	87.6
3.0-6.0	30-64	Average	102	9
6.5-10.0	65-100	Good	38	3.4
TOTAL			1129	100

The students who scored a 0 mark failed to differential the procedures of constructing a locus from a given point or specific point of a circle. These students didn't understand how to start tracing the point N of locus AB, instead construct a locus which started tracing the path from point N to B. This analysis show that the students failed to understand the question requirement. Figure 5 presents the range of score in terms of percentage of students who attempted this question.

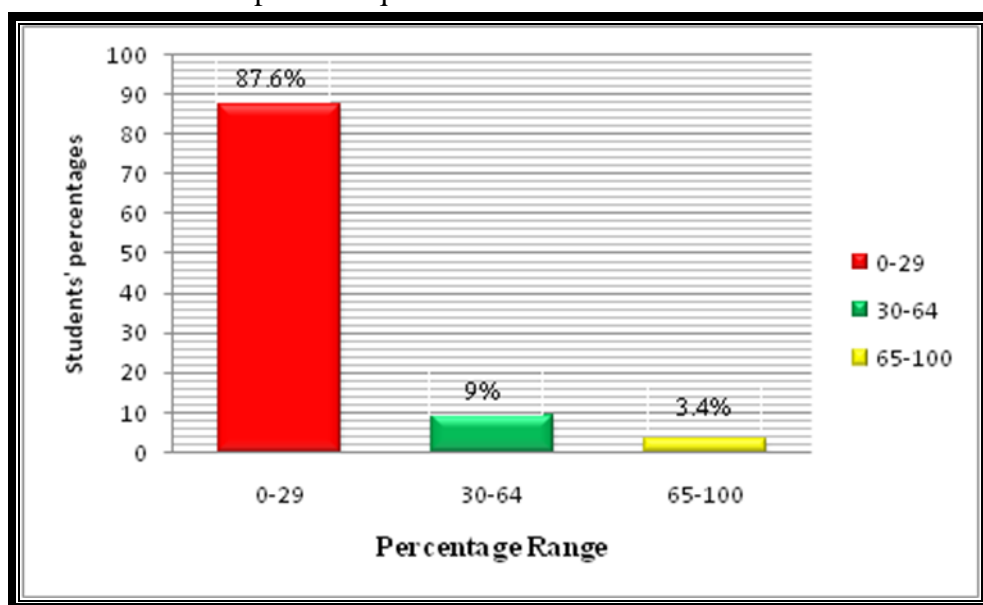

Figure 5: the range of score in terms of percentage for students who attempted Question 4.

The analysis revealed that most of students who attempted this question lacked knowledge on the different methods of constructing loci. They had no concept on how to apply epicycloid method to construct a locus.

Extract 4.1 shows a sample of poor response by a student who provided a drawing which does not match the demand of the question and the response was taken from the student script.

4. Figure 2 shows a circle with centre O and a point N from which the circle touches the ground. Trace the path of a point N as the circle rolls without sliding along straight line AB on circle circumference. Name all the point used to obtain the path.

Extract 4.1: poor response by a student who provided a drawing which do not relate to the demand of the question.

Nevertheless, 3.4 percent of students scored from 6.5 to 10 marks. These students draw the completed locus and followed the principle of Loci mechanism. Students in this category were knowledgeable of cycloid locus

from other methods of constructing a locus. Those who scored higher marks mastery well the sub-topic of the Loci as sample of student shown in

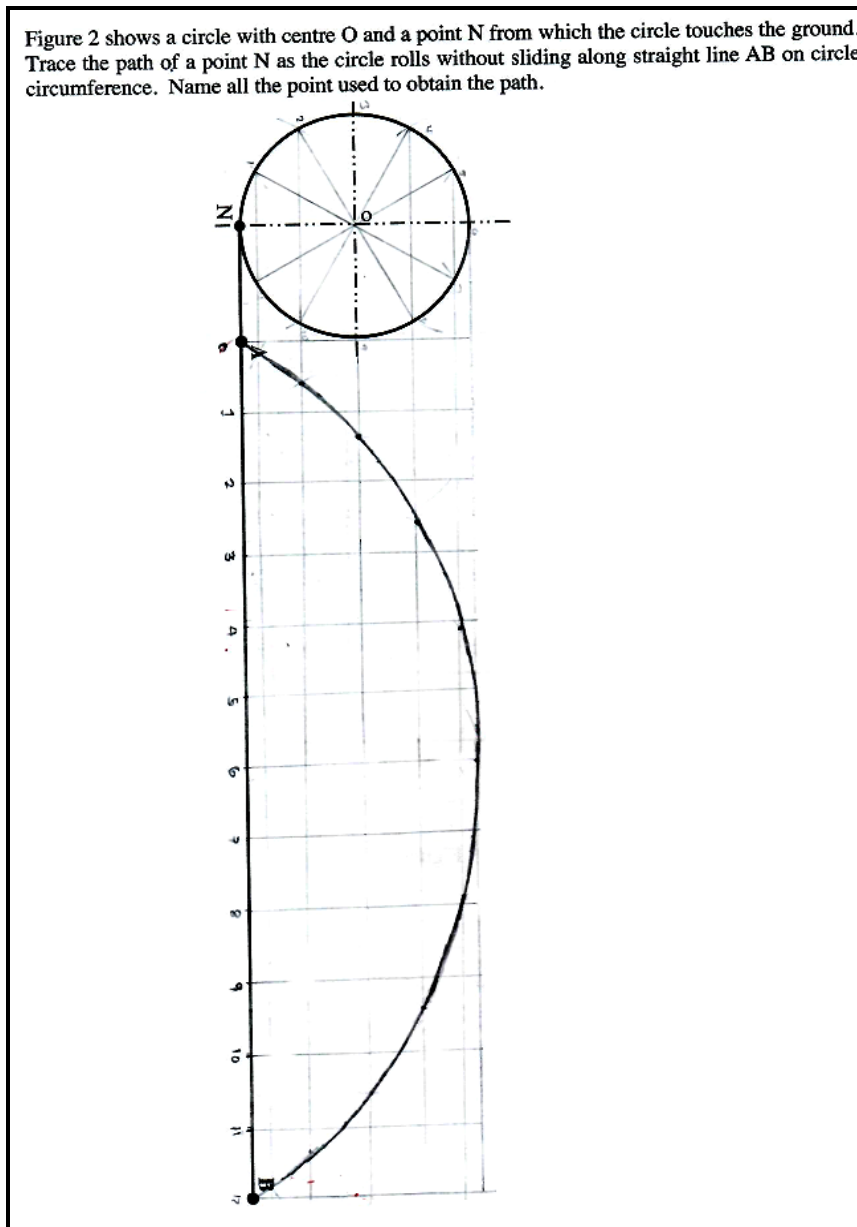

Extract 4.2: good response from one of the students

2.2 SECTION B: SELECTION OF TWO QUESTIONS

Section B had of three (3) questions from Pictorial, Auxiliary views and Orthographic topics. Candidates were instructed to answer only two (2) questions. Each question carried thirty (30) marks making a total of sixty (60) marks for section B.

ANALYSIS OF THE QUESTIONS

The analysis of performance for students in this section was categorised in the following ranges: from 0 to 29 percent which are 0 to 8.7 marks out of 30 marks as unsatisfactory, 30 to 64 percent which are 9 to 19.2 marks as average and 65 to 100 percent which are 19.5 to 30 marks as good.

2.2.1 Question 5: Auxiliary Views

A total of 1034 (69.63%) students out of 1485 sat for examination. The question demanded the students to re-draw the given views in third angle projection give views and add other auxiliary view looking to the arrow Q submerged at an angle 45° from horizontal. The question was: as follows:

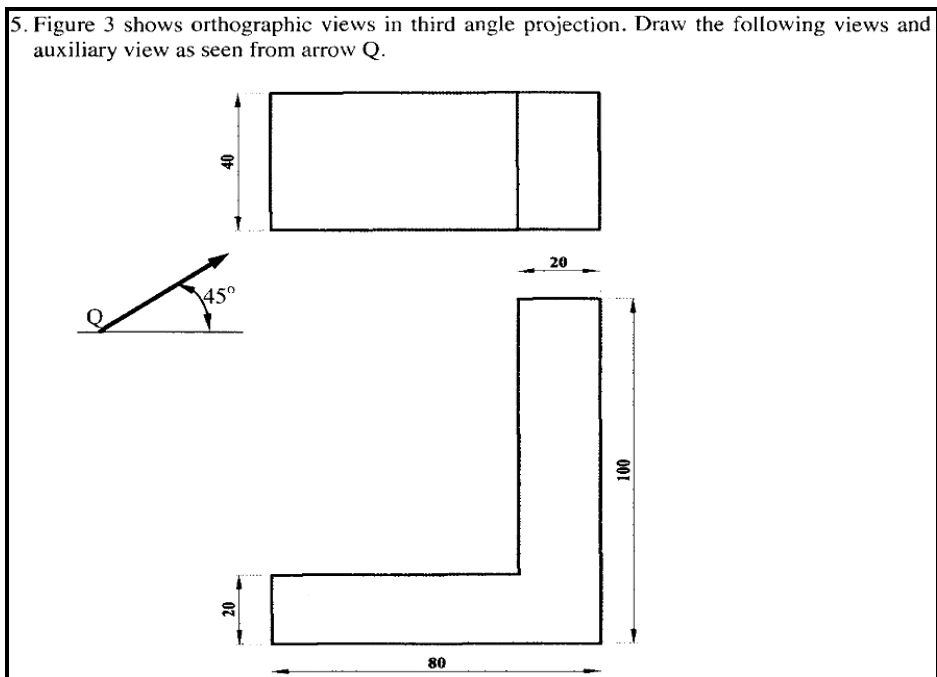

Generally, students' performance in this question was poor. 99.5% of students scored 0 to 29 percent which is 0 to 8.5 marks. This group of students managed to draw one of the given views in third angle projection but failed to complete the task. Likewise, 0.5 percent of students scored 30 to 64 percents which is 9 to 19.0 marks which that was considered as average pass. These students responded correctly to some parts but failed to complete the other parts. No students scored above 65 percents. Table 6 shows the description of performance of students for this question

Table 6: Trend of students' performance in Question 5

Marks Scored	Percentage Range	Description	Students	
			Total Number	Percentage
0 - 8.5	0 - 29	Unsatisfactory	1029	99.5
9 - 19.0	30 - 64	Average	5	0.5
19.5 - 30	65 - 100	Good	0	0
TOTAL			1034	100

The majority failure in this question shows that students lacked knowledge of pictorial views. They didn't identify the angle of projection and differentiate the methods of constructing an auxiliary view from orthographic projection. Also most of the students, didn't understand the difference between first angle projection and third angle projection with the auxiliary views projection. Figure 6 presents the summarised number of student against to marks scores in terms of percentage for students who did this question.

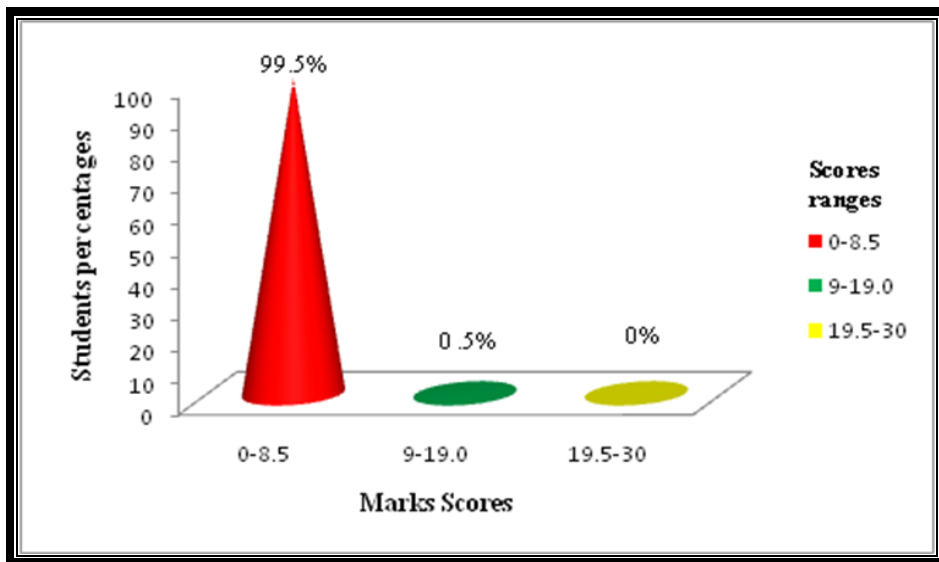
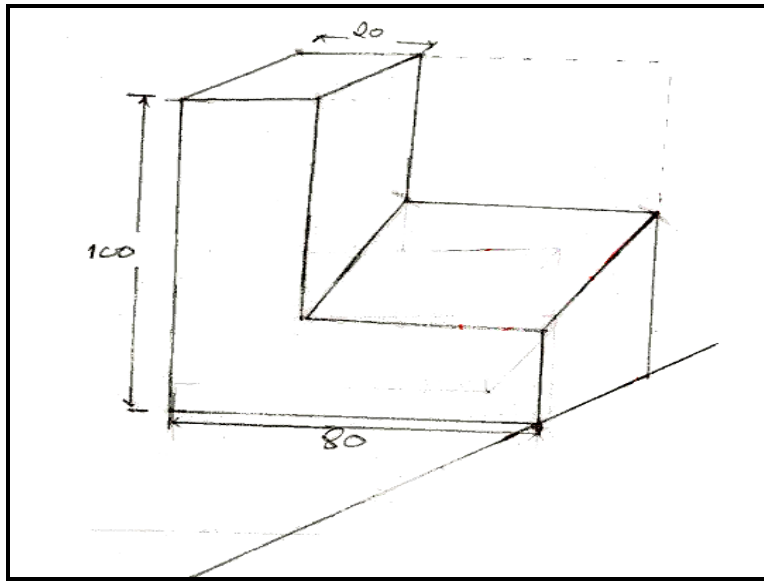
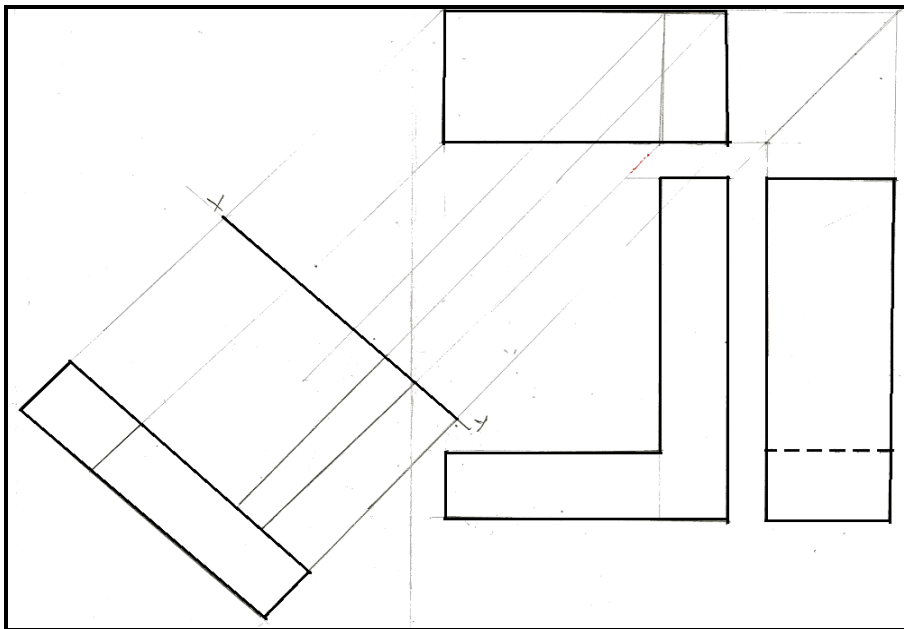

Figure 6: General student's performance in Question 5.

The student who had poor performance failed to attempt some parts of the question. These students had insufficient knowledge on the topic of orthographic projection and auxiliary view in first angle projection and auxiliary view in first and third angle projection. A few students with average performance managed to provide the correct answer but failed to exhaust all procedures on how to convert the orthographic view into auxiliary as the task required. Extracts 5.1 and 5.2 the samples of responses of students who failed to attempt the question and the one with good performance in Question 5 respectively.



Extract 5.1 shows a sample of poor responses.



Extract 5.2: is a sample of a response from a script of students who was able to construct an auxiliary view in third angle projection.

2.2.2 Question 6: Pictorial Drawing

Question 6 was set from the topic of Pictorial Drawing. In this question students were required to convert the three views which were given in third angle projection to the isometric projection. The question was:

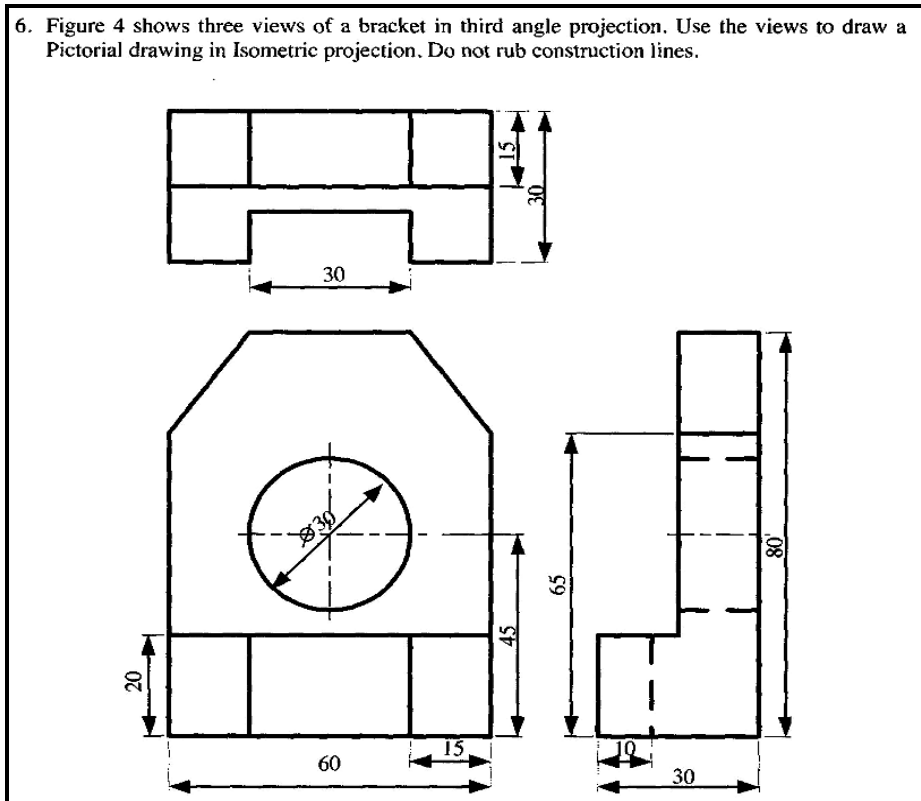

The question was attempted by 551 (37.1%) students. 413(75%) students scored from 0 to 8.5 marks, 49 (8.8%) students scored from 9 to 19.0 marks, Moreover, 89 (16.2%) students scored from 19.5 to 30 marks, 934 (63%) did not opt this question. Despite the fact that the question was within the scope, the students did not perform well as shown in Table 7 and Figure 7.

Table 7: Students' performance in Question 6

Marks Scored	Percentage Range	Performance	Students	
			Total Number	Percentage
0-8.5	0 - 29	Unsatisfactory	413	75
9-19.0	30 - 64	Average	49	8.8
19.5-30	65 - 100	Good	89	16.2
TOTAL			551	100

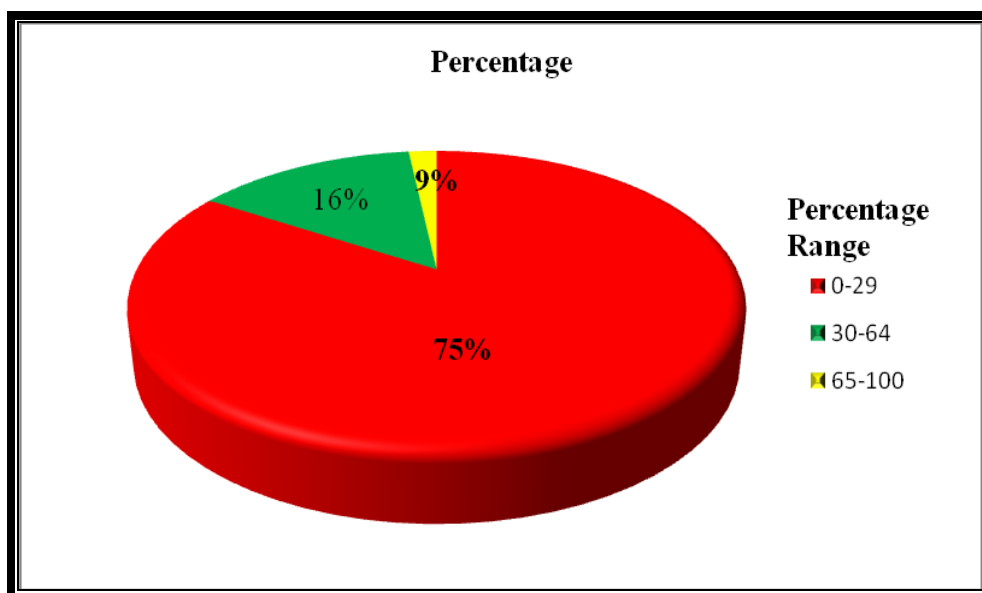
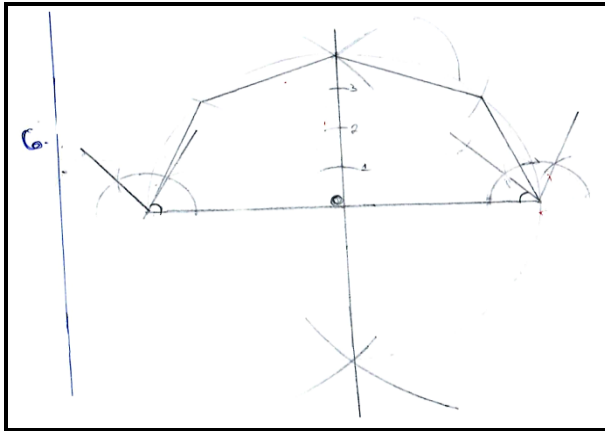

Figure 7: Summarised graphical groups of scores with respect percentage of students who did Question 6

This students' poor performance suggests that, students were not well taught skills related to the topic. The students who scored 0 mark lacked knowledge and skills on drawing of converting orthographic views to pictorial drawing. They failed to draw even an isometric box, where these three views should be constructed. Moreover, they failed to realise the steps of construct an isometric projection by drawing construction lines or paper layout. These Students demonstrated poor mastery of the topic matters as shown in Extract 6.1



Extract 6.1: poor response from a student who answered this question.

More than half of the students performed below average. A few students (17.2%) who scored from 19.5 to 30 marks managed to provide the correct answer but failed to exhaust all procedures on how to convert the orthographic view into isometric as the task required. A sample of an answer from a student who managed to convert the question from orthographic to isometric projection is presented in Extract 6.2.

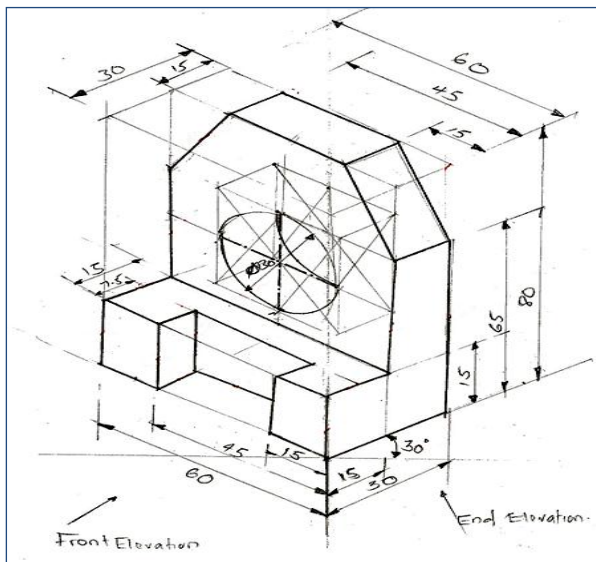

Extract 6.2: good response from one of the student who answered this question.

2.2.3 Question 7. Orthographic Projection

This question was on the topic called Pictorial Drawing. Students were required to convert the question from Isometric to Orthographic views. The question was:

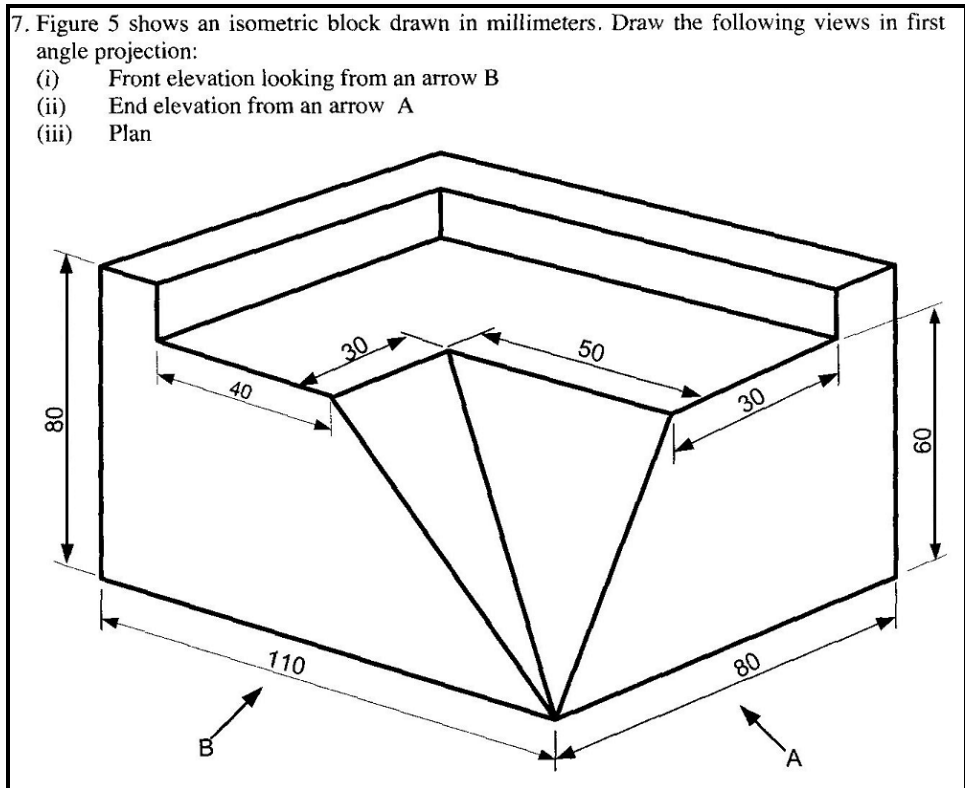

This question was attempted by 1131 (76.2%) students. 74.5 percent of students scored from 0 to 8.5 marks, while 16.5 percent of students scored from 3 to 6.0 marks and 102 (9%) students scored from 19.5 to 30 marks. The students who didn't attempt the question was 23.8 percent, which is equal to 354 students.

General performance of the students for this question was poor, as most of the students failed to understand the need of the question. The students were required to interpret the pictorial drawing (Isometric projection) to orthographic drawing (Front, Plan and Side views). Students who performed unsatisfactory lacked knowledge and skills of the question. Student do not understand the terms *Isometric and orthographic projection*.

Where Isometric is an axonometric projection in which three coordinate axes appear equally foreshortened, Orthographic projection is a means of representing three dimensional objects into two dimensions. Furthermore, students who presented good responses had enough knowledge on the pictorial and orthographic drawing. Table 8 and Figure 8 present the summarised groups of score in terms of percentage of student who did the question.

Table 8: A trend of students' performance in Question 7

Marks Scores	Percentage Range	Description	Candidates	
			Total Number	Percentage
0-8.5	0-29	Unsatisfactory	843	74.5
9-19.0	30-64	Average	186	16.5
19.5-30	65-100	Good	102	9
TOTAL			1131	100

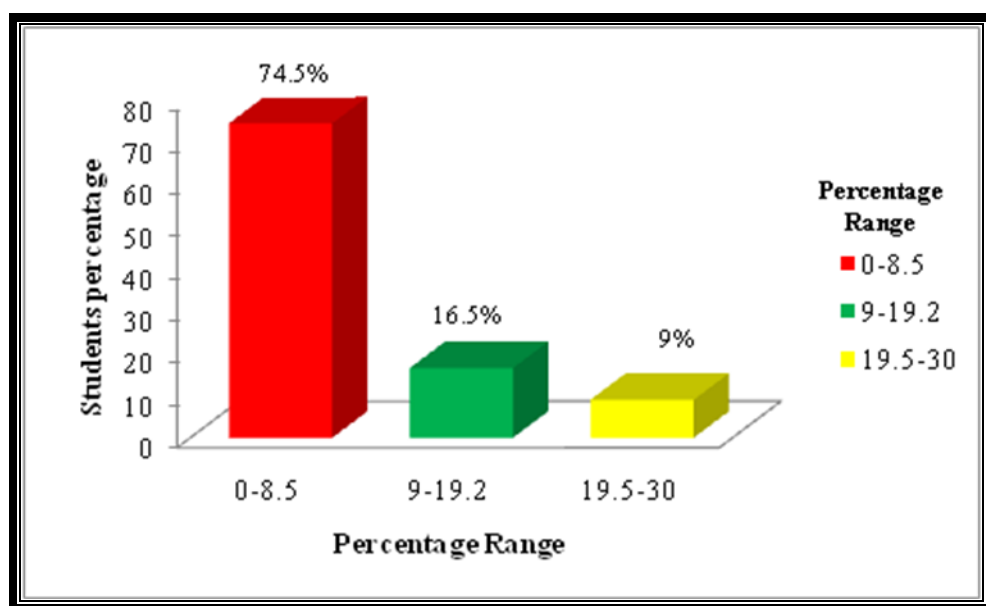
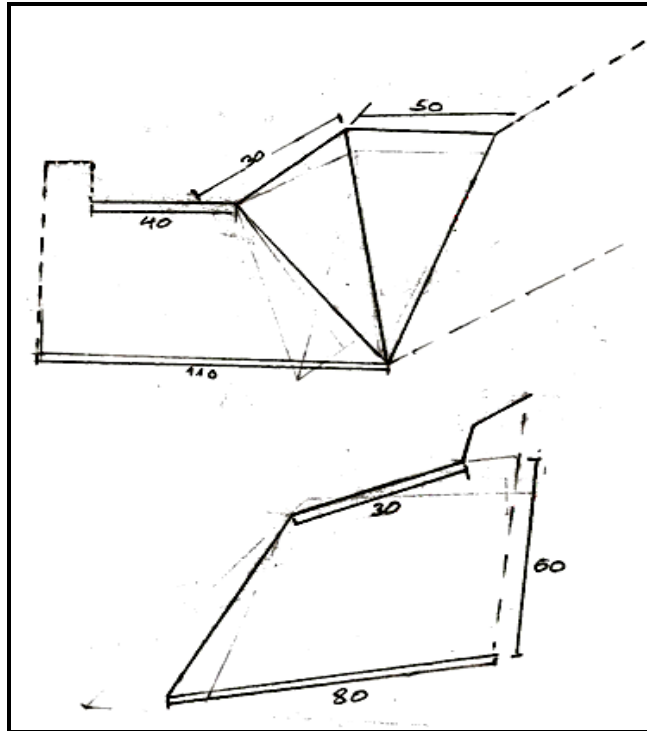

Figure 8: Summarised graphical groups of scores with respect percentage of students who did Question 7.

The students who scored 0 mark failed to attempt all parts of the question. They lacked knowledge of the concept of orthographic projection procedures, thus couldn't manage to convert Isometric to Orthographic

projection. Moreover, students failed to distinguish between first angle projection and third angle projection; hence they draw irrelevant views which do not correlate to the question. Extract 7.1 is a sample of poor response from one of the students' scripts.



Extract 7.1 a sample of poor orthographic projection from one of the students.

Some students who scored from 0 – 8.5 marks were able to identify the position of front, plan and end view with respect to the arrows given in the question. Other students managed to copy the figure given in isometric instead of bringing it onto orthographic view. This is due to lack of knowledge and practical skills in the topic of pictorial projection. Also students didn't conceptualise the position of views, angle of projection, scale given and direction of views in order to accommodate the requirements of the question. However, a few students scored 9.5 - 30 marks. These students were able to draw all the three views correctly and applied the correct position of Front, Top and Side view. These students had knowledge of pictorial and orthographic projection. Extract 7.2 is a

sample of good response that managed to interpret the pictorial drawing to orthographic views.

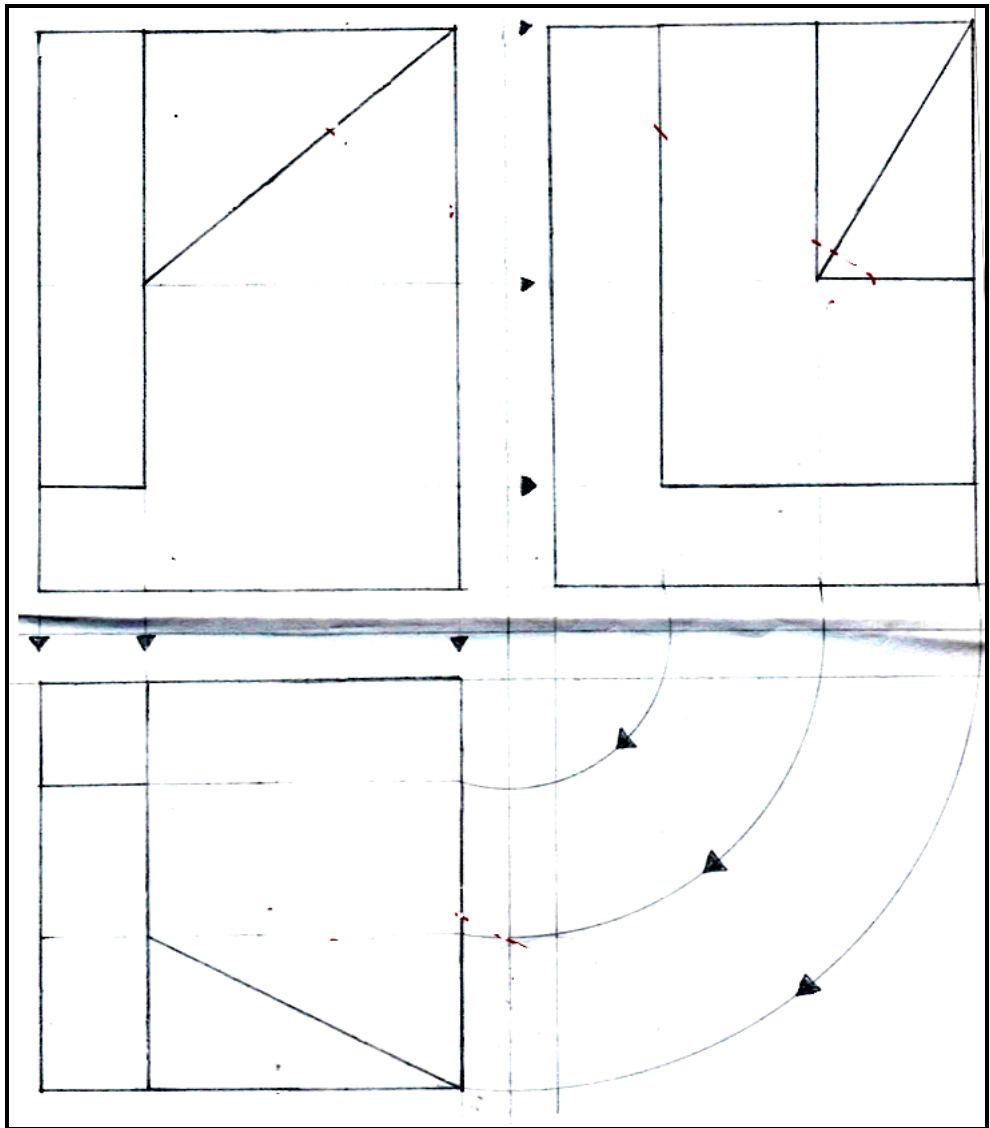

Extract 7.2: good response from one of the students who attempted question 7

3.0 CONCLUSION

On the basis of the students' responses analysis in each question, it can be concluded that the overall performance in Technical Drawing subject for the form Two National Assessment (FTNA) in 2018 was poor. This is justified by the fact that performed 84 percent of the students who sat for the examination was below average (*Appendix III*).

The analysis shows that the qualities of students' responses were affected by the following reasons:-

Inability of the students to identify the tasks of the questions, inadequate knowledge of the concepts related to topics and poor drawing skills.

Also, the students demonstrated poor mastery of the English Language which hindered them from identifying question's demand and flexibility in answering the questions.

Moreover, the students who performed well had good understanding of the concepts covered in the topics examined. Many of them attempted well in objectives questions, filling the blanks and drawing. Therefore, students are encouraged to work hard, think critically and do more practice knowing that Technical Drawing is the language of Engineering.

The analysis of students' performance shows that, Questions 1 and 2 were well performed. The poor performance of students was observed in Questions 3,4 and 5 where only 75.89 percent, 51.5 percent and 60.0 percent respectively scored 0 marks. These questions were set from Tangent, Locus and Auxiliary Views topics. (*Appendix I &II*)

Poor responses could be due to:

- (a) Shortage of professional technical drawing teachers or negligence of some students in putting substantial efforts in their studies.
- (b) Some topics were not fully covered by their teachers or students did not do enough exercises and revisions on the topics tested.

It is expected that the weaknesses noted and the feedback provided in this report will guide teachers and other educational stakeholders during teaching and learning process in order to rise the students' performance in the Technical Drawing subject.

4.0 RECOMMENDATIONS

From the shortcomings observed in the course of analysis, it is therefore recommended that:

4.1 Syllabus Covered

- (a) Teachers should cover all the topics in form I and 2 syllabi before the commencement of the assessment and make sure the students are able to use various concepts and methods of Technical Drawing subject. Teachers should also provide enough exercises and tests to students in order to reinforce their learning ability. This will determine students' readiness for the assessments.
- (b) The coverage of topic should be accompanied by reading various books, journals and past papers for the specific level so that it helps them to build expertise in various drawings. Moreover, reading and enough exercises will enable students to increase the speed in drawing and have enough experience of applying technical drawing techniques, concepts and guidelines in answering questions.
- (c) Since Technical Drawing is the Engineering language, students should be guided to acquire this knowledge in order to improve their technical communication and solve technical drawings problems.
- (d) School administrators and managers should make a close follow up of the Drawing infrastructure such as: drawing room, drawing equipments, drawing stationeries, drawing paper and drawing stencils.
- (e) English language teachers should assist students on reading skills for students to master English Language which can lead them to identify questions demand and flexibility in answering the questions.

4.2 Technical Professional Personnel

To enhance the industrial revolution manpower, the government through responsible ministry should ensure the availability of Technical professional personnel in Technical secondary schools. This will impact technical knowledge and skills to the students. This will help to produce the competent students who at the end of their course will be able to mitigate the industry labour problem.

Table 9: A summary of students performance (Question-wise) in Technical Drawing examination.

S/N	Topics	Question Number	Percentage of Students who Scored 30% or more	Remarks
1	Dimensions, Lines, paper Size, circles, Locus, Scales, Geometric Constructions, Orthographic projections, Lettering	1	71.04	Good
2	Orthographic projection Lines, Lettering, paper size, polygon construction free hand sketch, dimension, scale	2	97.51	Good
3	Tangent (Plane -Geometry)	3	0.67	Unsatisfactory
4	Locus	4	10.57	Unsatisfactory
5	Auxiliary Projection	5	0.13	Unsatisfactory
6	Isometric Projection	6	8.95	Unsatisfactory
7	Orthographic Projection	7	18.34	Unsatisfactory

Table 10: Description of performance of total students per question

DESCRIPTION	Qn1	Qn2	Qn3	Qn4	Qn 5	Qn6	Qn7
Unsatisfactory	430	37	1383	989	1029	413	843
Average	977	822	7	102	5	49	186
Good	78	626	0	38	0	89	102
TOTAL	1485	1485	1390	1129	1034	551	1131

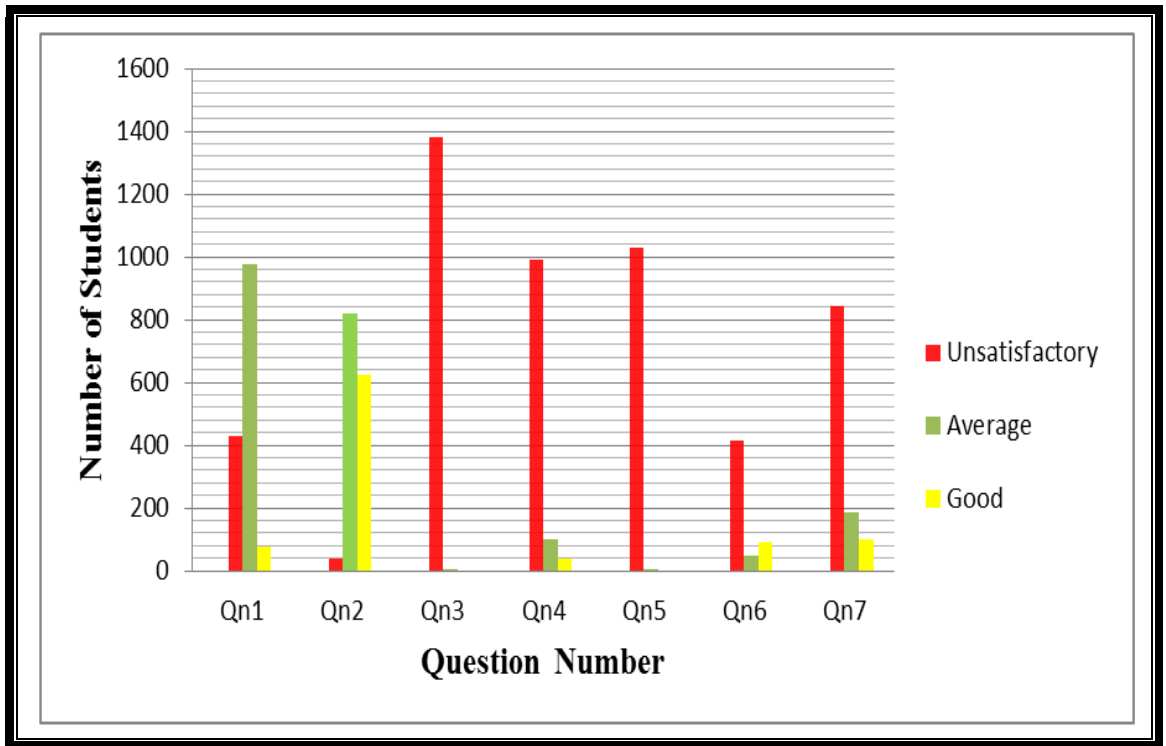

Figure 9: Performance of the students in 070 Technical Drawing per question wise

Table 11: Table shows the overall performance of marks scored by students versus percentage

Grade Ranges	Student Percentage
0-29	84%
30-64	14.20%
65-100	1.80%
TOTAL	100%

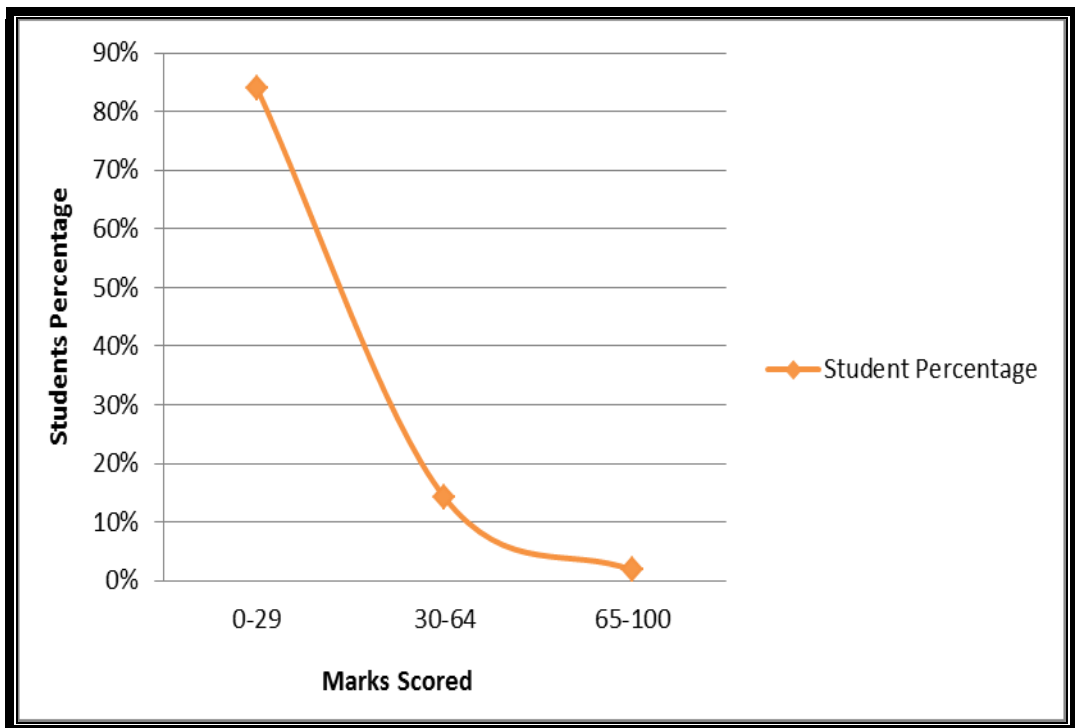

Figure 10: Trends of marks scored by students versus percentage

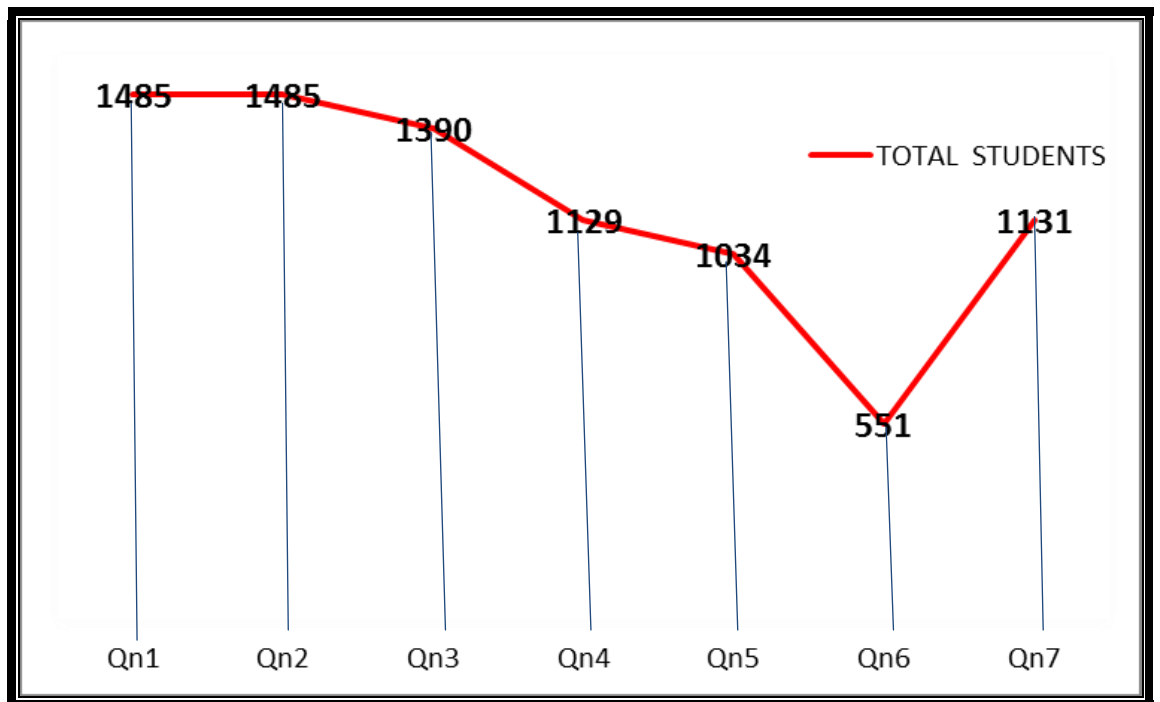

Figure 13: A total number of students per each question

