

The Intermec logo, featuring the word "Intermec" in a bold, blue, sans-serif font. The letter "I" is stylized with a blue triangle pointing to the right. The logo is positioned on the left side of the cover, partially overlaid by a large, light blue circular graphic element.

User's Guide



EasyCoder PM4i
Bar Code Label
Printer
(IPL Version)

Intermec Technologies Corporation
Corporate Headquarters
6001 36th Ave. W.
Everett, WA 98203
U.S.A.
www.intermec.com

The information contained herein is proprietary and is provided solely for the purpose of allowing customers to operate and service Intermec-manufactured equipment and is not to be released, reproduced, or used for any other purpose without written permission of Intermec.

Information and specifications contained in this document are subject to change without prior notice and do not represent a commitment on the part of Intermec Technologies Corporation.

© 2004 by Intermec Technologies Corporation. All rights reserved.

The word Intermec, the Intermec logo, Norand, ArciTech, CrossBar, Data Collection Browser, dcBrowser, Duratherm, EasyCoder, EasyLAN, Enterprise Wireless LAN, EZBuilder, Fingerprint, i-gistics, INCA (under license), InterDriver, Intermec Printer Network Manager, IRL, JANUS, LabelShop, Mobile Framework, MobileLAN, Nor*Ware, Pen*Key, Precision Print, PrintSet, RoutePower, TE 2000, Trakker Antares, UAP, Universal Access Point, and Virtual Wedge are either trademarks or registered trademarks of Intermec Technologies Corporation.

Throughout this manual, trademarked names may be used. Rather than put a trademark (™ or ®) symbol in every occurrence of a trademarked name, we state that we are using the names only in an editorial fashion, and to the benefit of the trademark owner, with no intention of infringement.

There are U.S. and foreign patents pending.

The name Centronics is wholly owned by GENICOM Corporation.

Kimdura is a registered trademark of Kimberly Clark.

Microsoft is a registered trademark of Microsoft Corporation.

Torx is a registered trademark of Camcar Division of Textron Inc.

TrueDoc is a registered trademark of Bitstream, Inc.

TrueType is a trademark of Apple Computer Inc.

Unicode is a trademark of Unicode Inc.

Valeron is a registered trademark of Valéron Strength Films, an ITW Company.

Windows is a trademark of Microsoft Corporation.

Document Change Record

This page records changes to this document. The document was originally released as version -00.

Version	Date	Description of Change
-00	May 2003	Supports original IPL version (v2.00).
-01	Oct. 2003	Revised to support IPL v2.10. Information about EasyLAN Wireless interface added.
-02	Feb. 2004	Revised to support IPL v2.20. Information on Intermec Readiness Indicator added. New method for returning to factory default added. More bar codes supported.
-52	June 2004	
-03	August 2004	Revised to support IPL v2.30. Support for USB interface, ribbon low sensor, and paper sensor. Extended setup mode. Support for composite bar codes.

Version -00 to -09 are original versions in US English.

Version -50 to -59 are Chinese translations.

Contents

Before You Begin.....	ix
Safety Summary.....	ix
Safety Icons	x
Global Services and Support	xi
Warranty Information.....	xi
Web Support	xi
Telephone Support	xi
Related Documents	xi

1 Introduction

Description of EasyCoder PM4i Printer.....	2
Safety Summary	3
Product Identification	3

2 Installation

Unpacking the Printer.....	6
Front View.....	7
Rear View	8
Media Compartment	9
Description.....	9
Media Supply Roll Post	10
Print Mechanism.....	11
Connections.....	12
Power	12
Computer.....	12
Controls and Indicators	13
Indicator Lamps	13
Display	14
Keyboard	14
Beeper	15

3 Starting Up

Switching On the Printer	18
--------------------------------	----

4

Media Load

Tear-Off (Straight-through)	20
Peel-Off (Self-strip)	24
Cut-Off.....	29
External Supply (Fanfold)	33
Rotating Media Supply	34

5

Thermal Transfer Printing

Ribbon Load.....	36
------------------	----

6

Setting Up the Printer

Description.....	42
Default Setup.....	43
Setup Parameters.....	44
Serial Communication.....	44
Baud Rate	44
Character Length	44
Parity.....	44
Stop Bits.....	45
Protocol	45
Test/Service	47
Testprint.....	47
Data Dump.....	48
Memory Reset.....	48
LSS Test	48
Media	49
Media Type	49
Paper Type.....	49
Label Length	49
Sensitivity.....	49
Darkness	50
Label Reset Point.....	50
Form Adj Dots X	50
Form Adj Dots Y.....	50
Ribbon Low	50
Paper Low (option)	50
Configuration	51
Emulation	51
Print Speed.....	51

Cutter	51
Label Taken Sensor.....	51
Returning to Factory Default Setup	52

7 Setup Mode

Navigating in Setup Mode	54
Setup Mode Overviews	56

8 Options

Introduction	62
Integral Liner Takeup Unit.....	63
Paper Cutter.....	63
Media Supply Hub.....	63
Paper Sensor.....	63
Media Roll Retainer	63
3-inch Adapter	63
Label Taken Sensor	64
Internal Fan-Fold Guide	64
Side Door with Keylock	64
Paper Sensor.....	64
Thick Media Printhead	64
Interface Boards	64

9 Troubleshooting

Intermec Readiness Indicator	66
Troubleshooting List	69

10 Maintenance

Printhead Cleaning	72
External Cleaning	75
Cleaning the Media Guides.....	76
Printhead Replacement	77
Media Jams	80

11 Adjustments

Narrow Media.....	82
Label Stop Sensor.....	83

Contents

Printhead Pressure	86
Ribbon Break Shaft	87

A Technical Specifications

Technical Data	90
----------------------	----

B Media Specifications

Media Roll Size	94
Media	95
Non-Adhesive Strip	95
Self-Adhesive Strip	96
Self-Adhesive Labels.....	97
Tickets with Gap	99
Tickets with Black Mark.....	101

C Interfaces

RS-232 Interface	104
USB Interface	105
Optional Interfaces	106

D Intermec Supplies

Setting the Media Sensitivity Number	110
--	-----

Before You Begin

This section provides you with safety information, technical support information, and sources for additional product information.

Safety Summary

Your safety is extremely important. Read and follow all warnings and cautions in this document before handling and operating Intermec equipment. You can be seriously injured, and equipment and data can be damaged if you do not follow the safety warnings and cautions.

Do not repair or adjust alone

Do not repair or adjust energized equipment alone under any circumstances. Someone capable of providing first aid must always be present for your safety.

First aid

Always obtain first aid or medical attention immediately after an injury. Never neglect an injury, no matter how slight it seems.

Resuscitation

Begin resuscitation immediately if someone is injured and stops breathing. Any delay could result in death. To work on or near high voltage, you should be familiar with approved industrial first aid methods.

Energized equipment

Never work on energized equipment unless authorized by a responsible authority. Energized electrical equipment is dangerous. Electrical shock from energized equipment can cause death. If you must perform authorized emergency work on energized equipment, be sure that you comply strictly with approved safety regulations.

Safety Icons

This section explains how to identify and understand dangers, warnings, cautions, and notes that are in this document. You may also see icons that tell you when to follow ESD procedures.



A warning alerts you of an operating procedure, practice, condition, or statement that must be strictly observed to avoid death or serious injury to the persons working on the equipment.



A caution alerts you to an operating procedure, practice, condition, or statement that must be strictly observed to prevent equipment damage or destruction, or corruption or loss of data.



This icon appears at the beginning of any procedure in this manual that could cause you to touch components (such as printed circuit boards) that are susceptible to damage from electrostatic discharge (ESD). When you see this icon, you must follow standard ESD guidelines to avoid damaging the equipment you are servicing.



Note: Notes either provide extra information about a topic or contain special instructions for handling a particular condition or set of circumstances.

Global Services and Support

Warranty Information

To understand the warranty for your Intermec product, visit the Intermec web site at <http://www.intermec.com> and click Service & Support. The Intermec Global Sales & Service page appears. From the Service & Support menu, move your pointer over Support, and then click Warranty.

Web Support

Visit the Intermec web site at <http://www.intermec.com> to download our current documents in PDF format. To order printed versions of the Intermec manuals, contact your local Intermec representative or distributor.

Visit the Intermec technical knowledge base (Knowledge Central) at <http://intermec.custhelp.com> to review technical information or to request technical support for your Intermec product.

Telephone Support

Contact your local Intermec representative. To search for your local representative, from the Intermec web site, click **Contact**.

Related Documents

The Intermec web site at <http://www.intermec.com> contains our current documents that you can download in PDF format. To order printed versions of the Intermec manuals, contact your local Intermec representative or distributor.

Before You Begin



1 Introduction

This chapter introduces the EasyCoder PM4i printer. The chapter covers the following topics:

- Description of EasyCoder PM4i
- Safety summary
- Product identification

Description of EasyCoder PM4i Printer

The EasyCoder PM4i is a sturdy thermal transfer printer with a printhead resolution of 8 dots/mm = 203.2 dots/inch and a maximum print width of 104 mm (4.095 inches). It offers a large number of useful features, such as:

- Flash memory SIMMs for firmware, fonts, bar codes, and application programs
- Built-in CompactFlash memory card adapter for firmware upgrading
- Built-in RS-232 interface
- Provision for extra interface boards including wired and wireless EasyLAN connections
- Keyboard and display with backlight for improved user interface.

A large number of factory-installed or field-installable options are available, so the printer can be configured for a wide range of applications. See Chapter 9 and Appendix A for more information.

The EasyCoder PM4i supports the Intermec Programming Language (IPL v2.30). A version of EasyCoder PM4i, that supports Intermec Fingerprint v8.30, is described in a special User's Guide.

Safety Summary

Intermec assumes no responsibility regarding the CE Directive if the printer is handled, modified, or installed in any way other than that described in Intermec's manuals.

- Read this manual carefully before connecting the printer.
- Moving parts are exposed when the side doors are open, so ensure that the doors are closed before you operate the printer.
- Do not open the front/left-hand cover. Dangerous voltage!
- Do not remove the bottom plate. Dangerous voltage!
- Do not put your fingers inside the print mechanism when the power is on.
- Make sure that the side door cannot unintentionally swing down when you have your fingers or hands inside the media compartment. Risk of injury because of the weight of the side door!
- Place the printer on an even surface which can support its weight of approximately 13.5 kg (30 pounds) plus supplies.
- Do not spray the printer with water. If you are using a hose to clean the premises in an industrial environment, remove the printer or protect it carefully from spray and moisture.
- Carefully read the warning text on the envelope before using a cleaning card.

Product Identification

The machine label is attached to the printer's rear plate and contains information on type, model, and serial number as well as AC voltage. It also contains various signs of approval.



2 Installation

This chapter explains how to unpack and install the EasyCoder PM4i and also describes the printer's various parts in detail. It covers the following topics:

- Unpacking the printer
- Parts on the printer's front
- Parts on the printer's rear plate
- Parts in the media compartment
- Parts in the print mechanism
- Connecting the printer
- Using the controls and understanding the indicators

Unpacking the Printer

Before you install the printer, examine the package for possible damage or missing parts:

- Open the box and lift the printer out.
- Check that the printer has not been visibly damaged during transportation. Keep the packing materials in case you need to move or reship the printer.
- Check the label on the printer's rear plate, which gives the voltage, the part number, and the serial number.
- Check that any options you ordered are included.
- Check that all the accessories are included. As standard, the box contains:
 - Intermec EasyCoder PM4i printer
 - Power cord
 - Quality check card
 - Cleaning card
 - High edge guide for media supply post
 - This User's Guide
 - Supporting software and product information on CD.
- Check that the type of power cord is appropriate for the local standard. The printer works within 90 to 265 VAC, 50 to 60 Hz.

If the printer has been damaged in any way during transportation, complain to the carrier immediately.

If the delivery is incorrect or any parts are missing, report it immediately to the distributor.

Front View

At the front of the printer are the display window, the indicator lamps, and the keyboard. These features allow the operator to control and set up the printer manually.

The printed labels, tickets, or tags are presented at the front of the print mechanism, which is covered by a door.

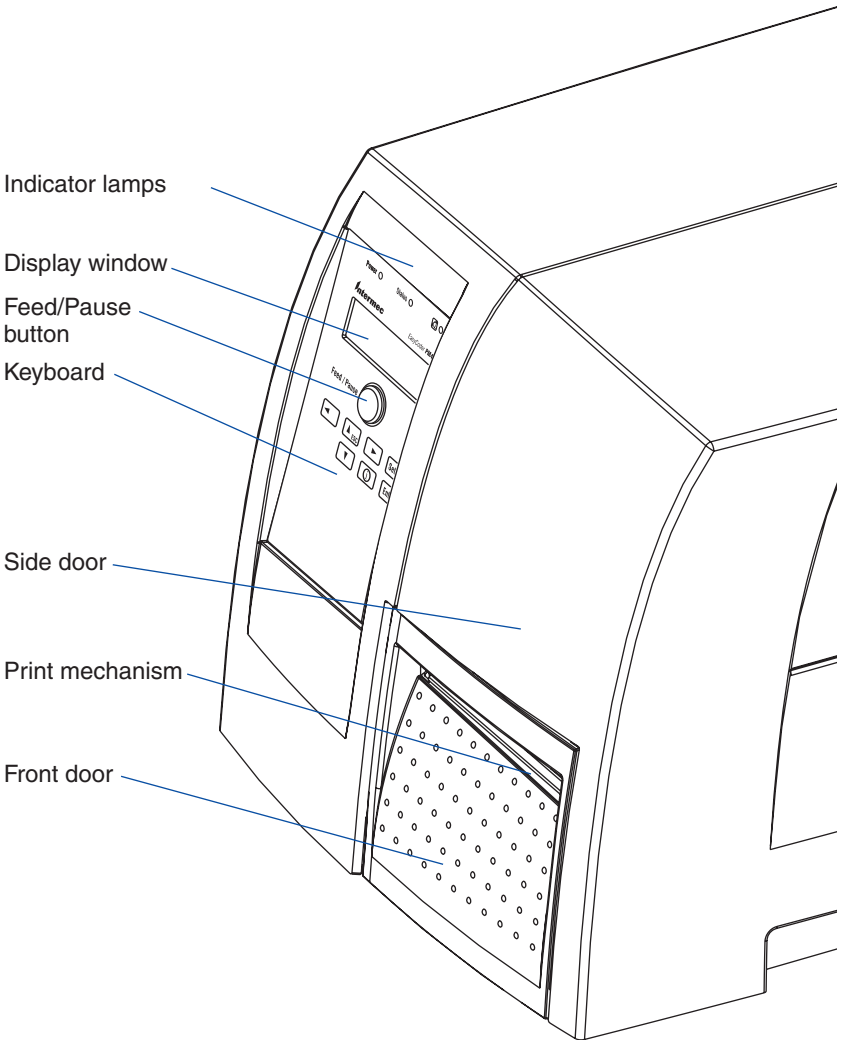

Rear View

The rear plate contains the On/Off switch, the AC power cord socket, and various interface connectors and slots.

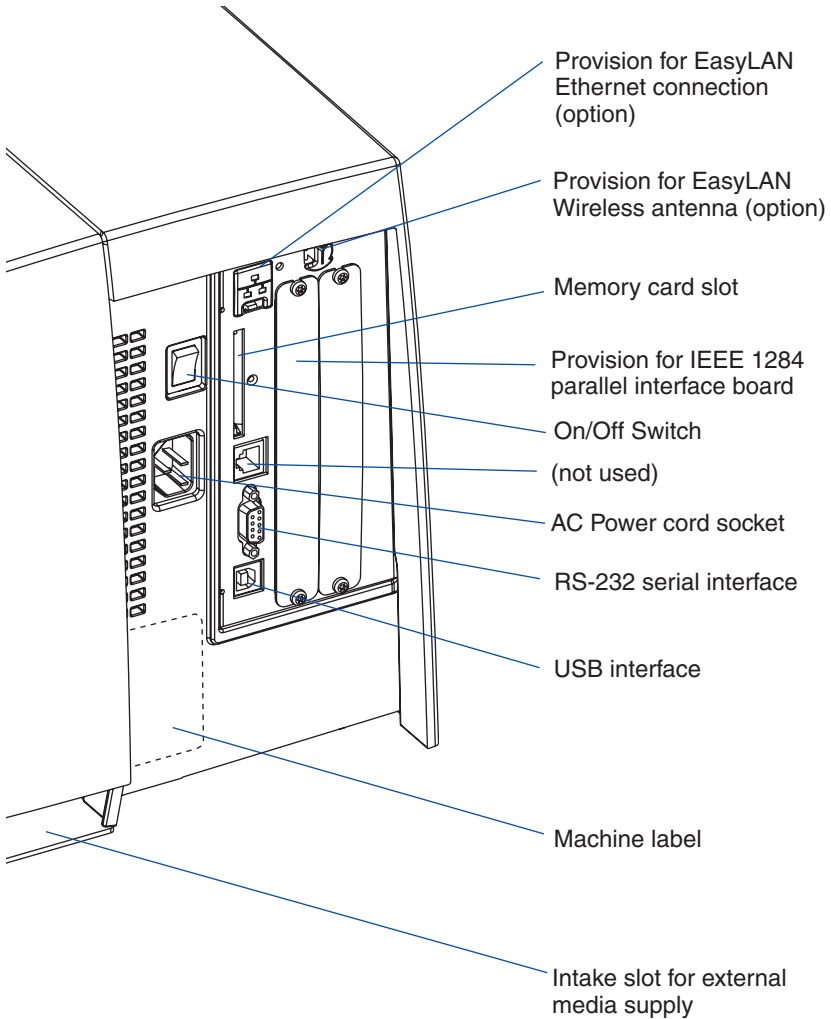

Media Compartment

Description

The media compartment is completely covered by a door that can be opened 180° upwards to provide full access for media and ribbon load and has an inspection window for checking the media and transfer ribbon supplies.

The media can be supplied from a post or, optionally, from an external supply of fan folds behind the printer using an internal media guide device. There is also an optional rotating media supply hub. Also see Chapter 9, “Options.”

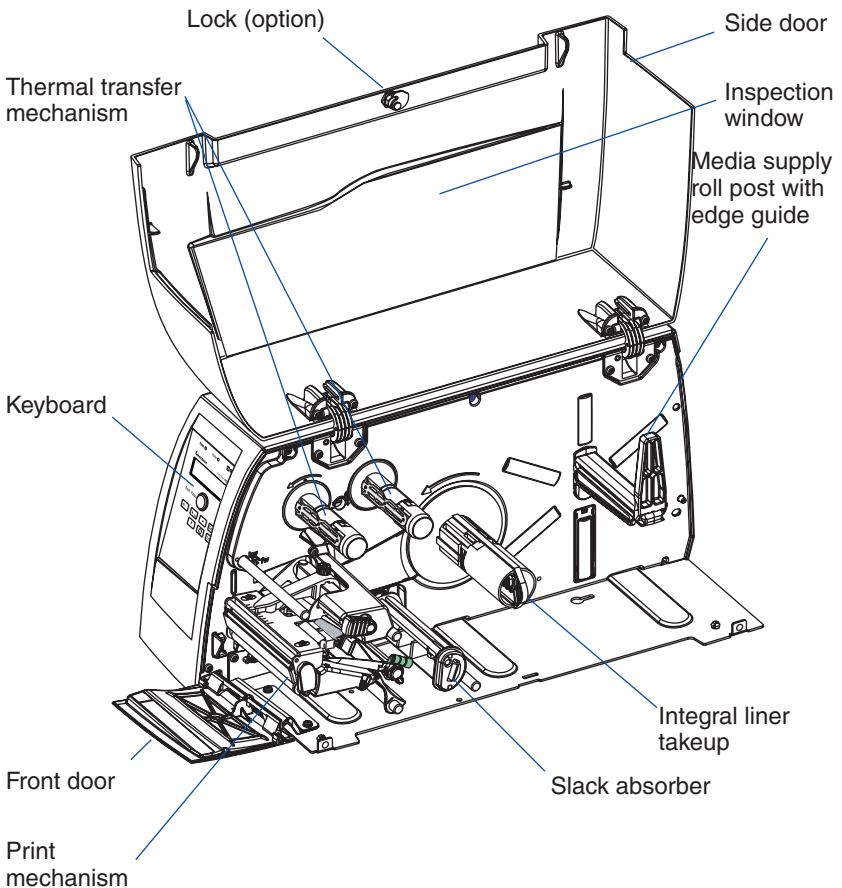

Media Supply Roll Post

The media supply roll post fits both 38-40 mm (1.5 inches) and 76 mm (3.0 inches) cores because it can be moved up or down in a slot in the center section. The bottom position is intended for small cores and the top position is for large cores. The post is locked by a straight-slot screw.

The post has a moveable edge guide to fit various media widths. As standard, a low guide is factory-fitted on the post and a high guide is packed separately with the other printer accessories. When switching the edge guide, be careful not to break it. In this manual, the high edge guide is generally illustrated.

When the edge guide is in its outermost position, it can be tilted down to a horizontal attitude to allow removal of the empty core and loading of a new media roll. After loading the media roll, tilt up the edge guide and push it inwards so the media roll becomes flush with the center section. The low edge guide allows media rolls with 3-inch cores to be loaded without tilting down the guide.

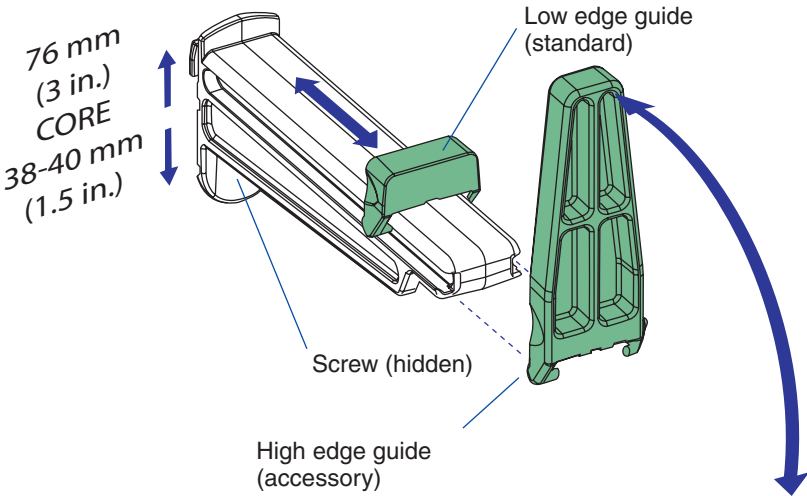

Optionally, the printer can be fitted with an 1.5-inch rotating media supply hub instead of a post and a paper sensor, which detects when the remaining amount of media has reached a level specified in the Setup Mode. There are also a 3-inch adapter and a label roll retainer. Another option is an internal guide for media placed behind the printer (for example fan-folds). For illustrations, see Chapter 8 "Options".

Print Mechanism

The print mechanism features a high-performance thermal printhead with quick-mount fittings to facilitate replacement.

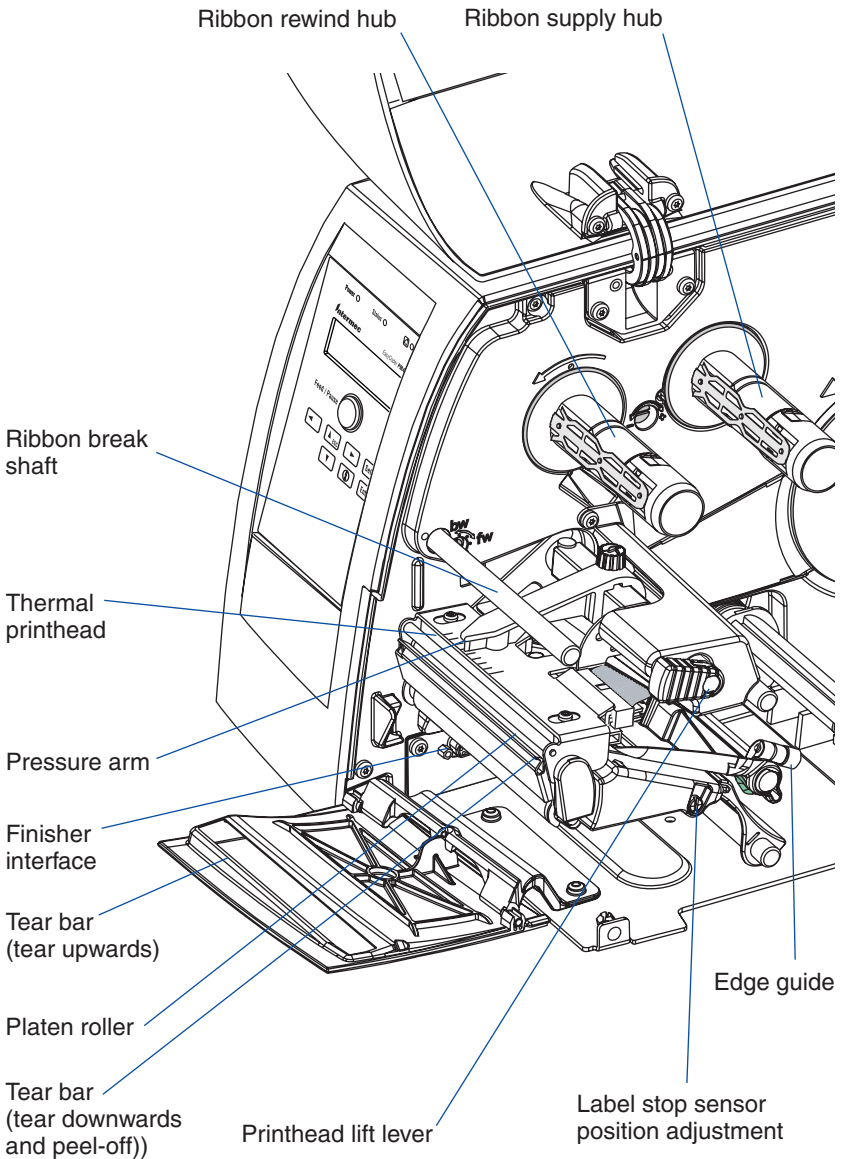

Connections

Power

- 1 Place the printer on a level surface, near an AC outlet. You should be able to easily access the printer to load media and to remove the print-out.
- 2 Check that the printer is switched off.
- 3 Connect the power cord from the socket on the rear plate to an electrical outlet (90 to 265 VAC).

Computer

The EasyCoder PM4i is fitted with one 9-pin D-style subminiature (DB9) socket for the RS-232 serial interface port (see Appendix C).

RS-232 Serial Interface

Before you can use the serial interface, you may need to set up the communication parameters, such as baud rate, parity, etc. as described in Chapter 6, “Setting Up the Printer.”

USB Interface

The printer supports USB v1.1. There is no communication setup for USB. For more information, refer to Appendix C.

Optional Interface and Network Boards

Several types are available (see Chapter 8, “Options”). Refer to Chapter 6, Chapter 7, and Appendix C for connection and setup instructions.

The printer scans all communication ports. When it detects incoming data on a port, the printer automatically switches to use that port for both input and output.

To get information in the display window on the active communication channels, press the <i> key.

Switch off both PC and printer before connecting them together.

Controls and Indicators

The EasyCoder PM4i has several ways of communicating directly with its operator: three colored indicator lamps, a display window, a membrane-switch keyboard with 8 keys and buttons on the printer's front, and a beeper.

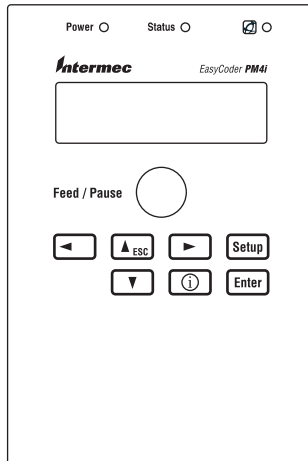

Indicator Lamps

The indicators are colored LEDs (Light Emitting Diodes) and are used for the following purposes:

- Power (solid green) indicates that the power is on.
- Status (solid green) indicates that the printer is ready for use.
- Status (flashing green) indicates that the printer is communicating.
- Status (solid red) indicates an error condition (see Chapter 9).
-  Intermec Readiness Indicator (blue; on, blink, or off).
Represented by a blue light on Intermec handheld computers, access points, and printers, the Intermec Readiness Indicator is part of an exclusive monitoring system from Intermec. The Intermec Readiness Indicator helps users quickly determine the readiness of the Intermec device individually and as part of a solution. The Intermec Readiness Indicator has three different states: On, Blinking, and Off. When the Indicator is off, the device is not ready to operate individually or as part of a solution. When the Indicator is blinking, the device may be initializing, waiting for external resources, or in need of user attention. And when the Indicator is On, the device is ready for use as part of a solution. Also see Chapter 9.





Display

The display window contains an LCD (Liquid Crystal Display) with background illumination and two lines of text, each with 16 characters. It shows a message when certain errors occur and guides the operator through upgrading, startup, and setup. The following errors are reported:

Error	Displayed message
Empty/Paused	PAUSE
Out of media	PAPER OUT
Out of ribbon	RIBBON OUT
Printhead lifted	PRINT HEAD UP/PRESS FEED
Cutter error	OPEN&SHUT CUTTER
Ribbon fitted	RIBBON FITTED
Paper fault	PAPER FAULT
Power supply error	PSU ERROR
Power supply too hot	PSU OVER TEMP
Printhead too hot	PRINTHEAD HOT

Keyboard

The keyboard is of the membrane-switch type and has 7 keys. The keyboard is supplemented by a large “Feed/Pause” button. Some keys have hard-coded functions in the startup and setup modes.

	Feed/Pause a print job. Repeat last printed label.
	Enter the Setup Mode (see Chapter 7).
	Display error messages and communication channel information.
 	Scroll between various types of information after pressing the <i>key. Possible error messages and information on active communication channels are shown in a loop.

Keyboard Color Code

Yellow	Operation of the printer (operator level)
Green	Setup or service (site or service technician level)
White	Data input to printer (operator or technician level)

Beeper

The beeper acknowledges that a key has been pressed. Optionally, an audible alarm can be enabled using an IPL command. It will start beeping at paper out and ribbon out and will continue beeping until the start of reload.



3 Starting Up

This chapter explains how to start up the printer after installation or after having been switched off.

Switching On the Printer

Before switching on the printer, make the necessary connections, insert any memory card you want to use, and check that the printhead is engaged.

Switch on the power using the On/Off switch on the rear plate. The “Power” control lamp on the front panel lights up when the power is on. Wait for a few moments, while the printer loads the program and runs some self-diagnostic tests:

```
Starting
```

```
■■■■■■■
```

After a short time, the printer is initialized. The progress of the initialization is indicated by an increasing number of colons on the lower line in the display:

```
Initializing
```

```
:::
```

When the initialization is completed, a label is fed out. The following message appears, indicating that the printer is ready for operation.

```
IPL 2.30
```

The message indicates the IPL version number.



4 Media Load

This chapter explains how to load the printer with media, that is labels, tickets, tag, or strips, for the following modes of operation:

- Tear-Off (straight-through)
- Peel-Off (self-strip), requires optional integral self-strip unit with liner takeup
- Cut-Off (requires optional cutter)
- External supply (fan-folds), fan-fold guide available as option

Tear-Off (Straight-through)

The EasyCoder PM4i can print on labels, tickets, tags, and continuous stock in various forms. This section describes the case when the media is torn off manually against the printer's tear bar. This method is also known as "straight-through printing."

Tear-off can be used for:

- Non-adhesive continuous stock
- Self-adhesive continuous stock with liner
- Self-adhesive labels with liner
- Tickets with gaps, with or without perforations
- Tickets with black marks, with or without perforations

An optional label taken sensor can hold the printing of the next copy in the batch until the present copy has been removed, see Chapter 8, "Options."



Note: Save the label indicating the sensitivity number attached to the media roll. You will need this number to set the media sensitivity, see Appendix D.

Tear-Off, cont.

1

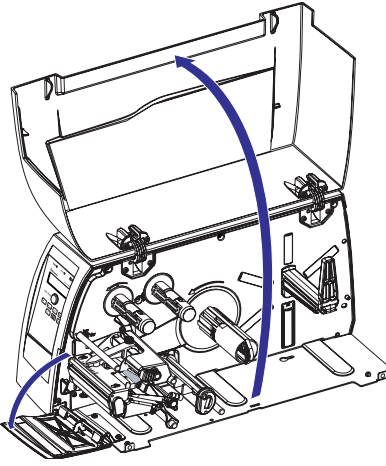

Open the front and side doors.

2

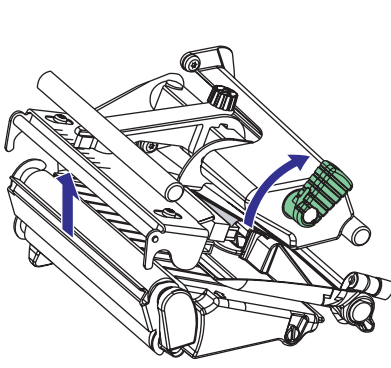

Turn the printhead lift lever clockwise to raise the printhead.

3

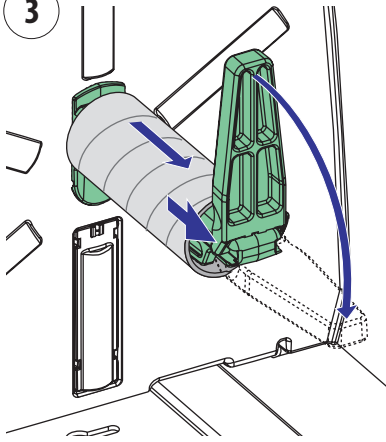

Pull out the edge guide as far as it goes and fold it down to a horizontal position. Remove any empty core from the media supply roll post.

4

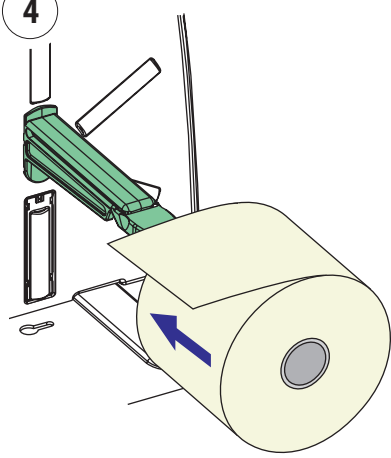

Fit a new roll of media on the supply post. Fold up and adjust the edge guide so the roll becomes flush with the center section.

Tear-Off, cont.

5

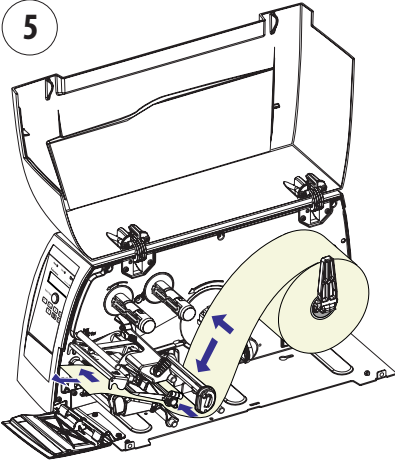

Route the media through the print mechanism and push it towards the center section as far as it goes.

6

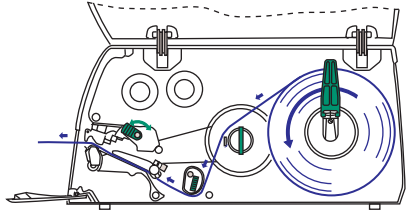

This diagram shows the media path.

7

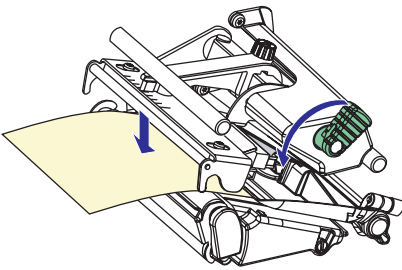

Turn the printhead lift lever counter-clockwise to engage the printhead.

8

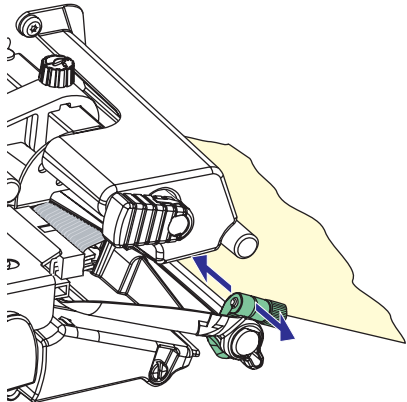

Adjust the position of the green edge guide so the media is guided with a minimum of play. Lock with the nut.

Tear-Off, cont.

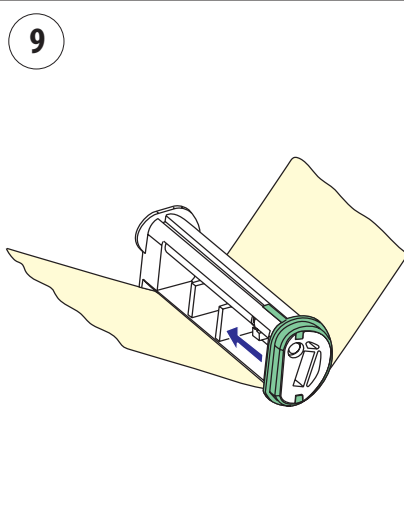

Adjust the position of the edge guide on the label slack absorber according to the width of the media.

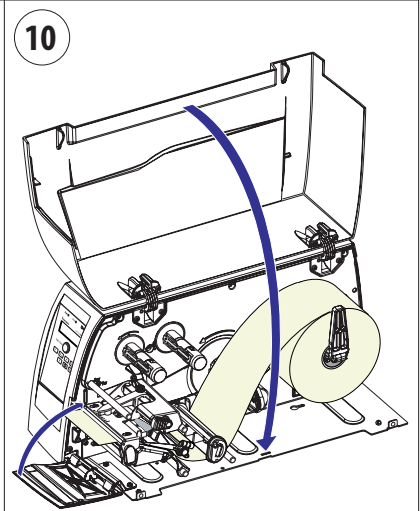

Close the front and side door, making sure that the media runs through the slot in the front door.

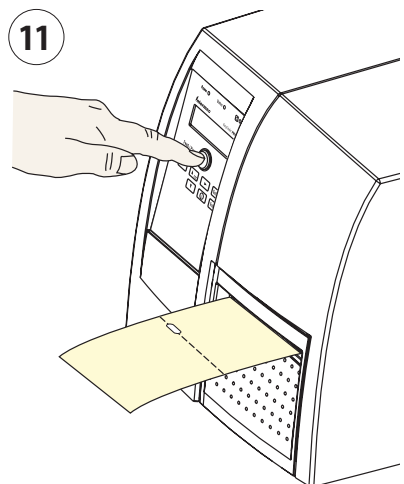

Press the Feed/Pause button to advance the media and adjust the media feed. Tear off the media by pulling it downwards.

Peel-Off (Self-strip)

The EasyCoder PM4i can print on labels, tickets, tags, and continuous stock in various forms. This section describes the case when self-adhesive labels are separated from the liner immediately after printing, which requires optional integral self-strip unit with liner takeup. This is also known as “Self-strip” operation.

Peel-off operation cannot be performed when an optional fan-fold guide fitted.

Peel-off can only be used for:

- Self-adhesive labels with liner

An optional label-taken sensor can hold the printing of the next label in a batch until the present label has been removed, see Chapter 8, “Options.”



Note: Save the label indicating the sensitivity number attached to the media roll. You will need this number to set the media sensitivity, see Appendix D.



Note: Peel-off operation sets high demands on the media in regard of label stiffness, release characteristics of the adhesive and liner, resistance against electrostatic charging etc., so the labels will be dispensed properly. Consult your media supplier or test the media to ascertain that it is suitable for your application.

Peel-Off, cont.

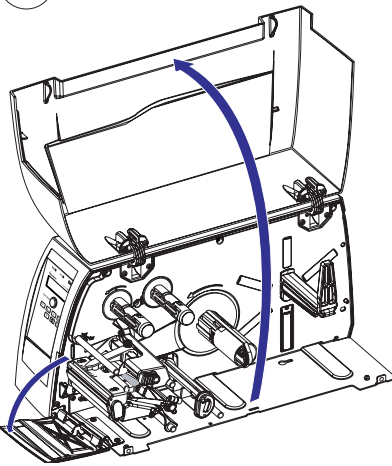
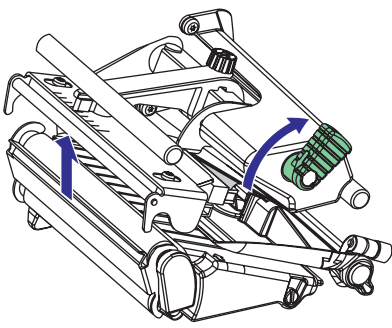
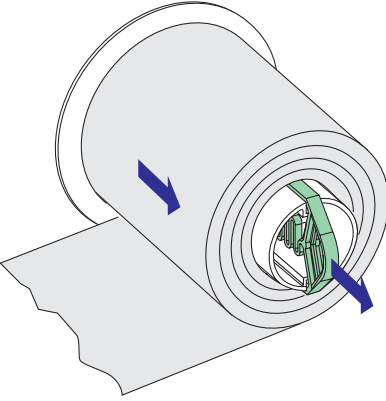
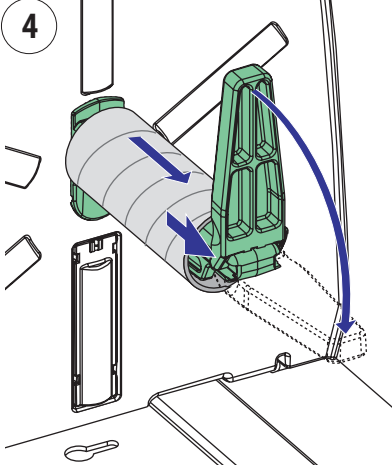
<p>1</p>  <p><i>Open the front and side doors.</i></p>	<p>2</p>  <p><i>Turn the printhead lift lever clockwise to raise the printhead.</i></p>
<p>3</p>  <p><i>Pull out the handle to collapse the takeup hub, then remove any liner.</i></p>	<p>4</p>  <p><i>Pull out the edge guide as far as it goes and fold it down to a horizontal position. Remove any empty core from the media supply roll post.</i></p>

Peel-Off, cont.

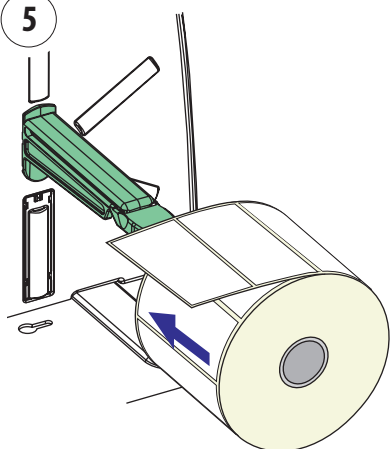
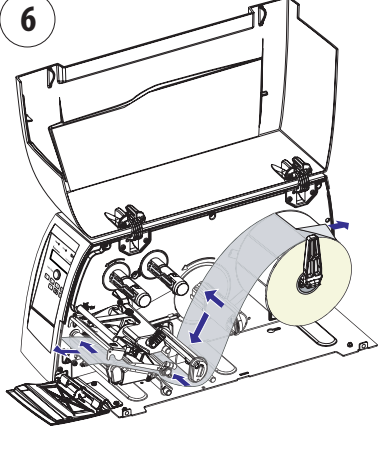
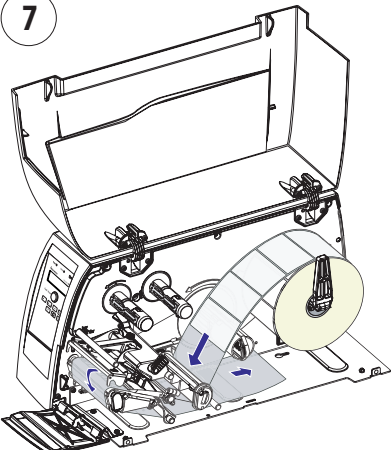
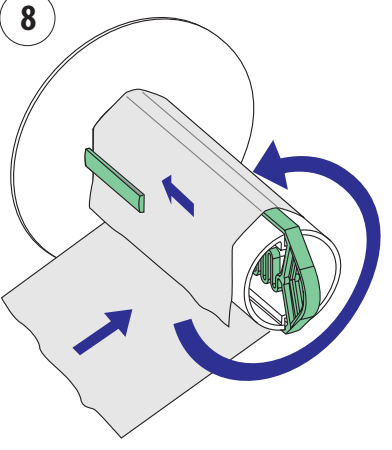
<p>5</p>  <p><i>Fit a new roll of media on the supply post. Fold up and adjust the edge guide so the roll becomes flush with the center section.</i></p>	<p>6</p>  <p><i>Remove labels from the first 50 cm (20 inches) of the liner. Route the liner through the print mechanism and push it inwards towards the center section as far as it goes.</i></p>
<p>7</p>  <p><i>Route the liner around the tear bar and the liner drive roller and back under the print mechanism and guide shafts.</i></p>	<p>8</p>  <p><i>Insert the start of the liner under the lip of the takeup hub, then rotate the hub counterclockwise a few turns to wind up some of the liner.</i></p>

Peel-Off, cont.

9

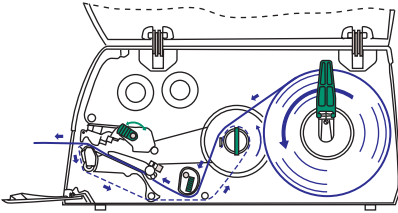

This diagram shows the media and liner paths.

10

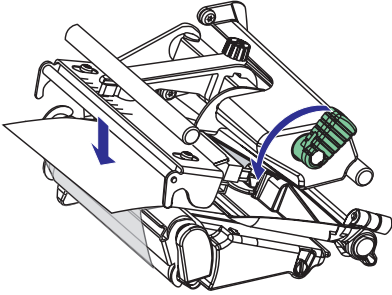

Turn the printhead lift lever counter-clockwise to engage the printhead.

11

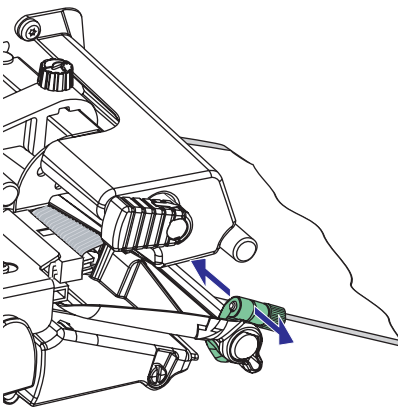

Adjust the position of the green edge guide so the media is guided with a minimum of play. Lock with the nut.

12

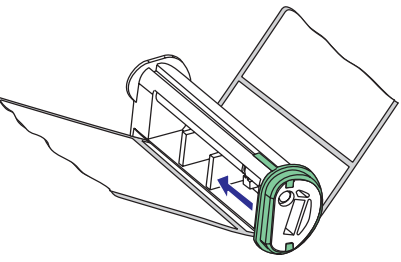

Adjust the position of the edge guide on the label slack absorber according to the width of the media.

Peel-Off, cont.

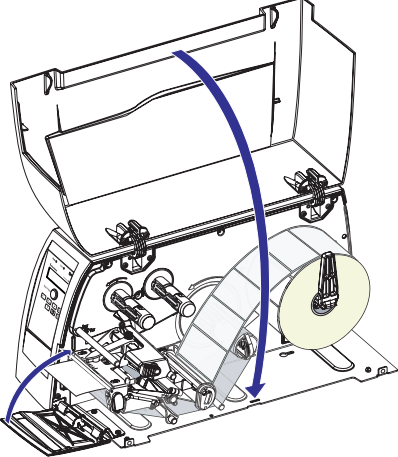
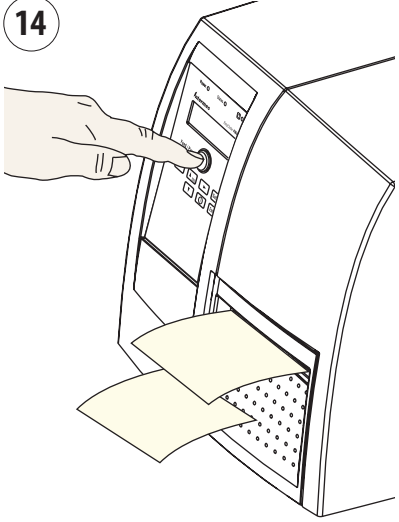
<p>13</p>  <p><i>Close the front and side doors.</i></p>	<p>14</p>  <p><i>Press the Feed/Pause button to advance the media and adjust the media feed.</i></p>
---	---

Cut-Off

The EasyCoder PM4i can print on labels, tickets, tags, and continuous stock in various forms. This section describes the case when the media is to be cut off by an automatic paper cutter (option).

Cut-off can be used for:

- Non-adhesive continuous stock
- Self-adhesive labels with liner (cut only liner between labels)

The cutter is designed to cut through paper-based media with a thickness between 60 and 175 μm , which roughly corresponds to a paper weight of 60 to 175 grams/m^2 (basis weight 40 to 120 lb). The cutter should not be used to cut through labels, because the adhesive will stick to the shears, which can damage the cutter.

The cutter is held by a latch inside the media compartment and can be tilted forward to facilitate media load. A switch prevents the cutter from operating when in open position.

The optional label taken sensor cannot be used with the cutter.

There is no front door when a cutter is installed.

The cutter can be fitted with an optional tray for collecting cut-off labels.



Note: Save the label indicating the sensitivity number attached to the media roll. You will need this number to set the media sensitivity, see Appendix D.

Cut-Off, cont.

1

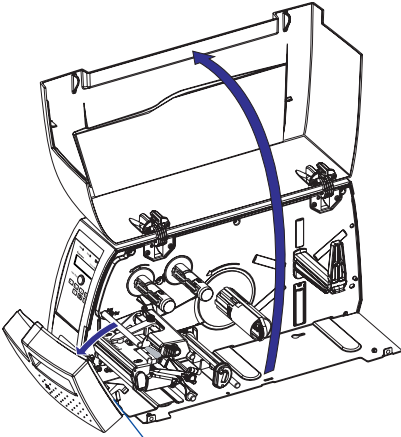

Latch

Open the cutter and the side door.

2

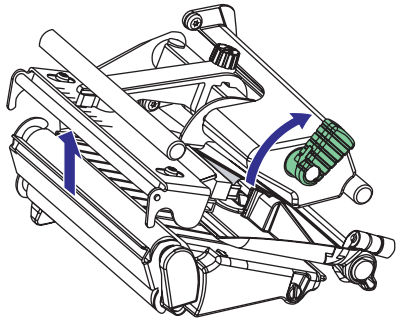

Turn the printhead lift lever clockwise to raise the printhead.

3

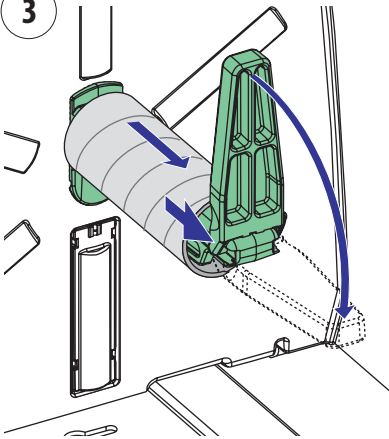

Pull out the edge guide as far as it goes and fold it down to a horizontal position. Remove any empty core from the media supply roll post.

4

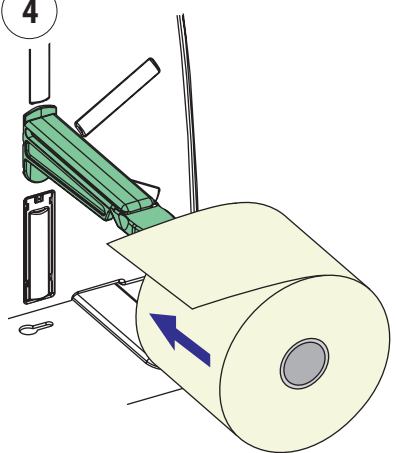

Fit a new roll of media on the supply post. Fold up and adjust the edge guide so the roll becomes flush with the center section.

Cut-Off, cont.

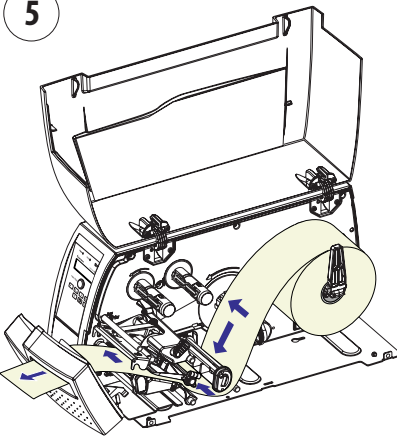
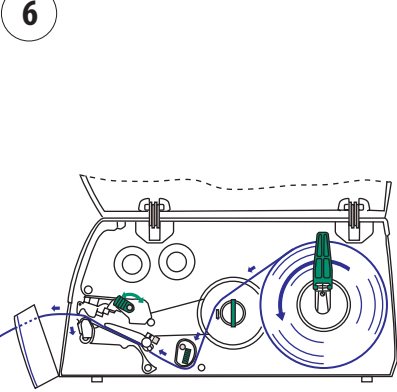
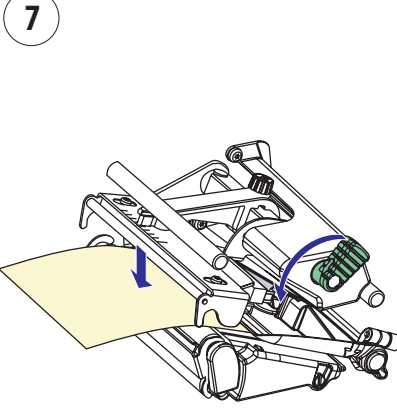
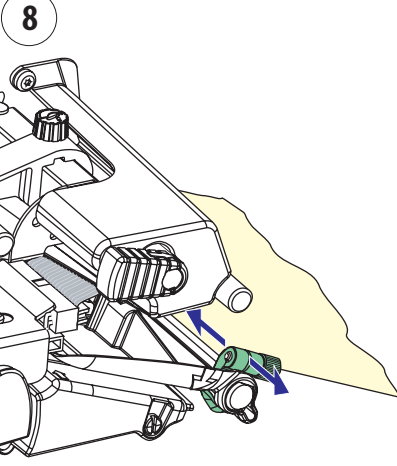
<p>5</p>  <p>Route the media through the print mechanism and cutter. Then push it towards the center section as far as it will go.</p>	<p>6</p>  <p>This diagram shows the media path.</p>
<p>7</p>  <p>Turn the printhead lift lever counter-clockwise to engage the printhead.</p>	<p>8</p>  <p>Adjust the position of the green edge guide so the media is guided with a minimum of play. Lock with the nut.</p>

Cut-Off, cont.

9

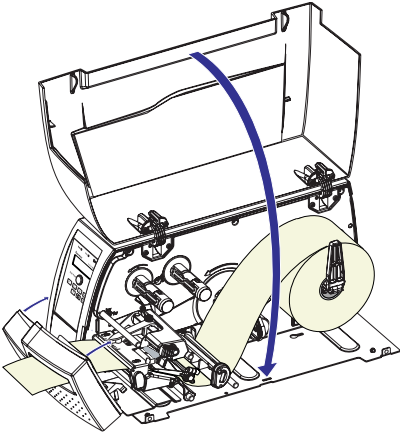

Close the side door and the cutter while pulling the media tight.

10

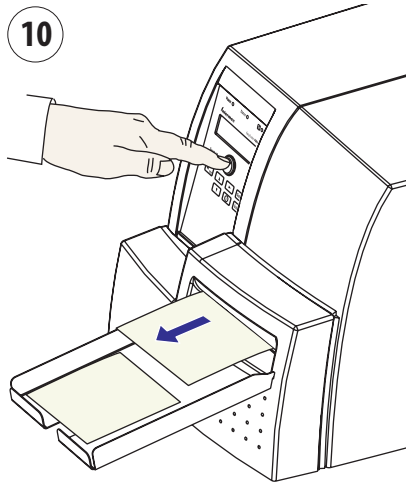

Press the Feed/Pause button to advance the media and adjust the media feed. The labels can be collected on an optional tray.

External Supply (Fan-fold)

The EasyCoder PM4i can print on labels, tickets, tags, and continuous stock in various forms. This section describes the case when the media supply is placed behind the printer, usually in the form of fan-folded tickets or tags. External supply can be used with tear-off (straight-through) and cut-off printing.

Although it is possible to simply feed the media through the hole in the rear part of the side door and directly to the print mechanism, we strongly recommend using a printer fitted with a special fan-fold guide as illustrated below. Not only does it make media loading much easier, but it also guides the media with great accuracy. The fan-fold guide can be adjusted for various media widths down to 40 mm (1.57 inches).

When using an external media supply, take care to protect the media from dust, dirt or other foreign particles, that can impair the printout quality or cause unnecessary wear to the printhead.

Depending on brand and quality, all direct thermal media are more or less sensitive to heat, direct sunlight, moisture, oil, plasticizers, fat, and other substances. Protect the media accordingly.

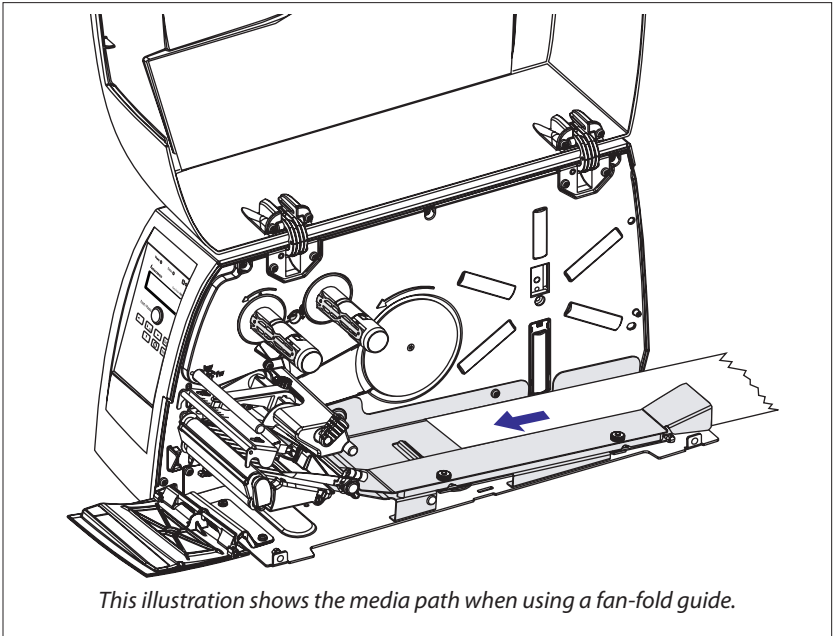

Rotating Media Supply

The EasyCoder PM4i can, as an alternative to the standard media supply roll post, use an optional rotating media supply hub, regardless of tear-off, cut-off, or peel-off operation.

The rotating media supply hub can be supplemented by an adapter for media rolls with a 76 mm (3 inches) core, a media roll retainer which prevents the media roll from uncoiling, and a paper low sensor, that can detect when the remaining supply of media reaches a predetermined level. Also refer to Chapter 6, “Setting Up the Printer” and Chapter 8, “Options.”

Media loading corresponds to the use of a media supply roll post, but the media roll needs to be pressed sideways onto the hub, making sure that it becomes flush with the disc at the inner end of the hub.

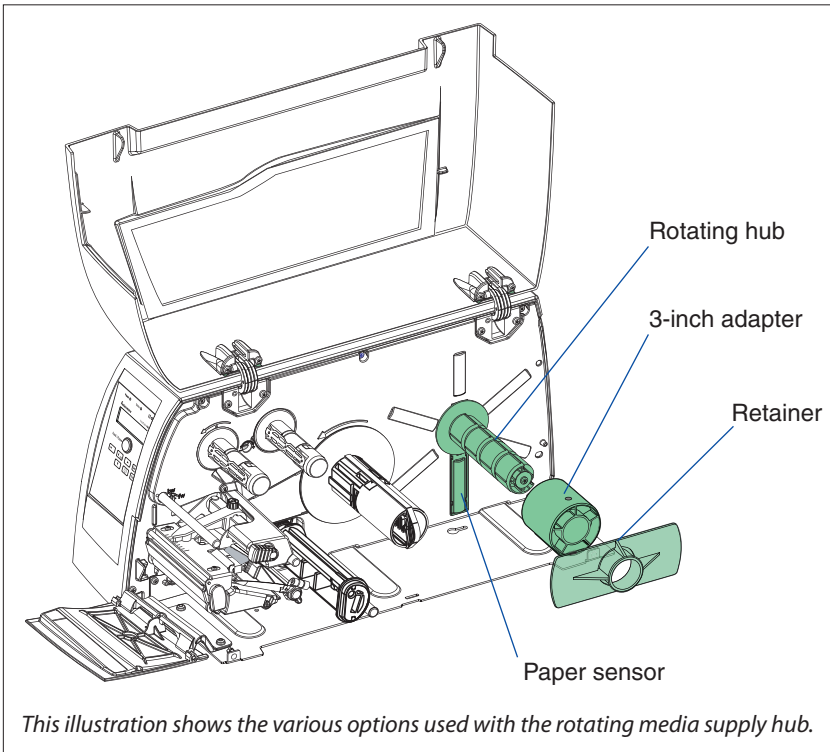

This illustration shows the various options used with the rotating media supply hub.

A decorative graphic consisting of two overlapping circles. The larger circle is light gray and partially encloses the smaller circle. The smaller circle is also light gray and has a small dark gray dot at its top-right intersection with the larger circle.

5 Thermal Transfer Printing

This chapter explains how to load the printer with ribbon for thermal transfer printing.

Ribbon Load

The EasyCoder PM4i can print on labels, tickets, tags, and continuous stock using either direct thermal printing on special heat-sensitive media or thermal transfer printing using a special ink-coated ribbon.

Thermal transfer printing makes it possible to use a wide range of receiving face materials and gives a durable printout less vulnerable to fat, chemicals, heat, sunlight etc. than direct thermal printing. Make sure to select a type of ribbon that matches the type of receiving face material and to set up the printer accordingly.

The EasyCoder PM4i can use transfer ribbon rolls wound with the ink-coated side facing either outward or inward. Illustrations in this manual show the ink-coated side facing inward.

Even if ribbon usually is loaded in connection with media replenishment, no loaded media are shown in the illustrations in this chapter in order to give a clearer view of the ribbon path. Refer to Chapter 4 for media load instructions.

Most transfer ribbons do not smear at room temperature.



Note: Save the label indicating the sensitivity number attached to the ribbon roll. You will need this number to set the media sensitivity, see Appendix D.

Ribbon Load, cont.

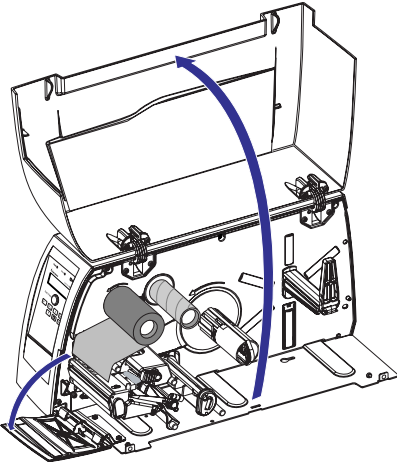
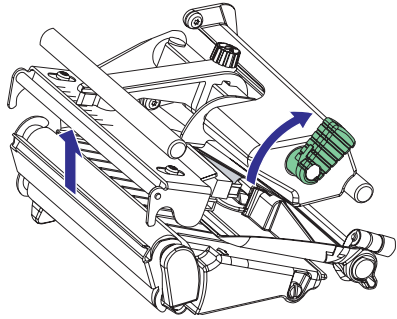
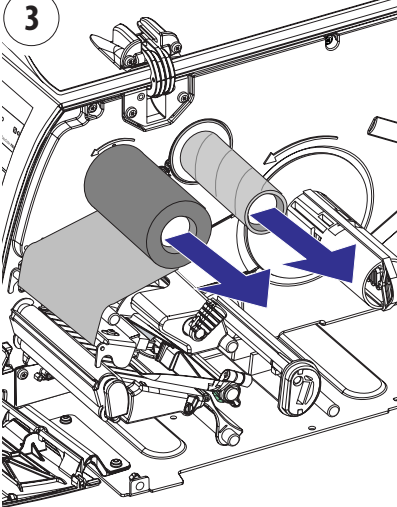
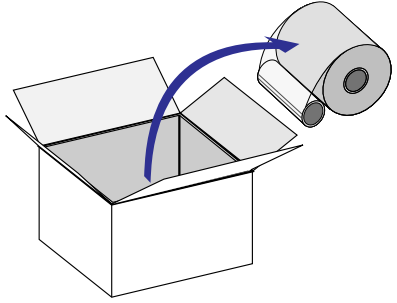
<p>1</p>  <p>Open the front and side doors.</p>	<p>2</p>  <p>Turn the printhead lift lever clockwise to raise the printhead.</p>
<p>3</p>  <p>In case of ribbon reload, remove any used ribbon and empty ribbon core.</p>	<p>4</p>  <p>Unpack a roll of original Intermec thermal transfer ribbon.</p>

Ribbon Load, cont.

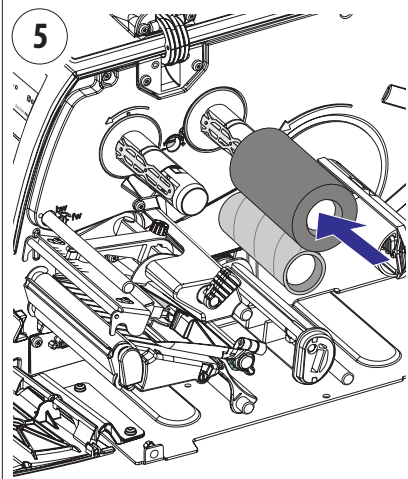

Slide the ribbon roll onto the supply hub so the ink-coated side faces down when the ribbon is routed through the print mechanism.

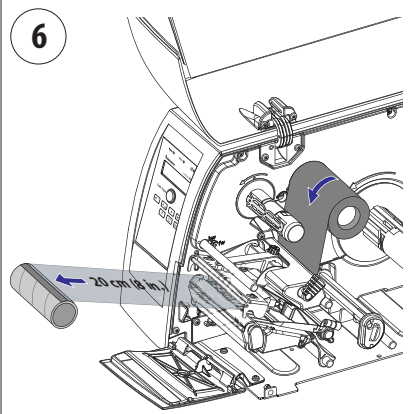

Route the ribbon through the print mechanism underneath the transparent upper LSS guide and pull out approximately 20 cm (8 inches) of ribbon leader.

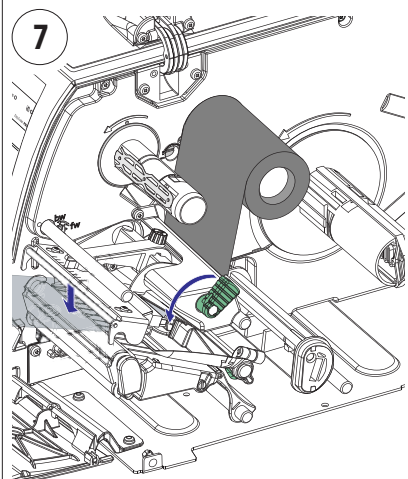

Without releasing the ribbon, turn the printhead lift lever counterclockwise to engage the printhead and lock the ribbon.

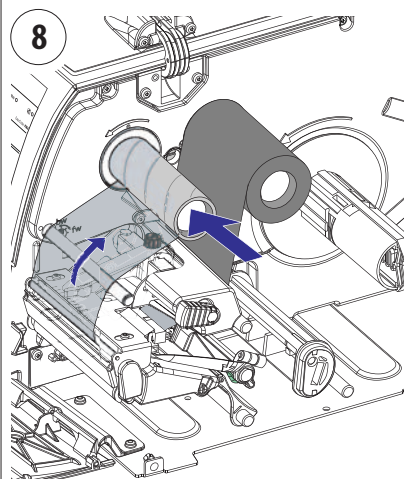

Slide the empty cardboard core onto the ribbon rewind hub so the ribbon is wound up when the hub rotates counterclockwise.

Ribbon Load, cont.

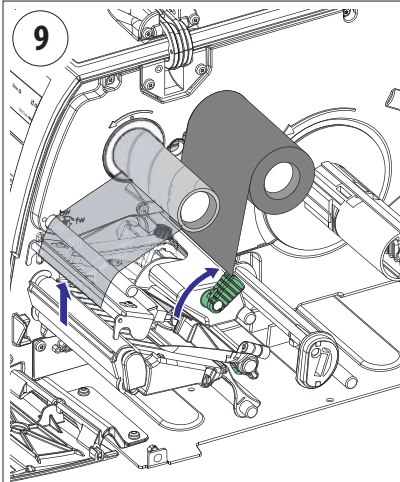

Turn the printhead lift lever clockwise to raise the printhead and release the ribbon.

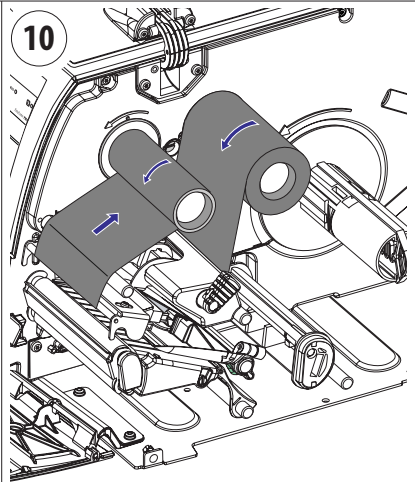

Manually advance the ribbon until all of the transparent leader has passed the printhead and the ribbon becomes tight.

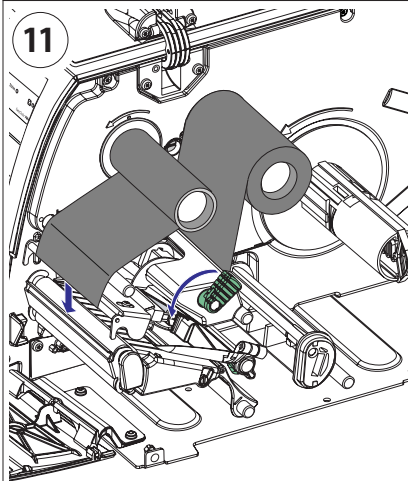

Turn the printhead lift knob counter-clockwise to engage the printhead.

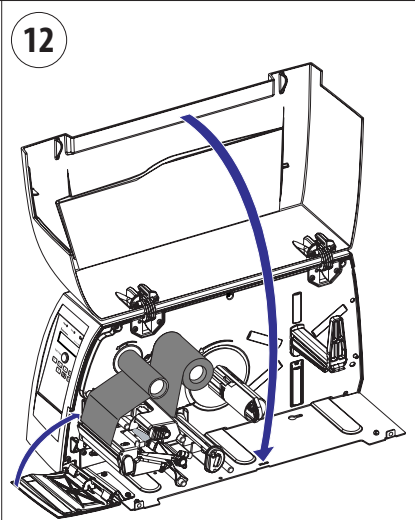

Close the front and side doors.



6 **Setting Up the Printer**

This chapter describes the various parameters that are used in the Setup Mode (see Chapter 7) or in the various application programs to configure the printer for the user's specific requirements. It covers the following topics:

- Description
- Default setup
- Setup Parameters in regard of communication, test/service, media, and configuration.

Description

The setup controls the printer in regard of serial communication, test and service operations, and specifies which types of media and ribbon are loaded in the printer.

Check the list below to see if the printer's default setup matches your requirements. If not, you will have to change the setup. To enter the Setup Mode, press the <**Setup**> key on the printer's built-in keyboard and follow the instructions in Chapter 7, "Setup Mode."

Default Setup

The printer's default setup is listed below (no options included):

Ser-Com	
Baud rate	9600 bps
Data bits	8 bits
Parity	None
Stop bits	1 bit
Protocol	XON/XOFF
Test/Service	
Testprint	not applicable
Data dump	No
Memory reset	not applicable
Media	
Media type	Gap
Paper type	DT
Label length	1200 dots
Sensitivity	420
Darkness	0%
Label rest point	0 dots
Form adj dots X	0 dots
Form adj dots Y	0 dots
Low diameter (ribbon)	0 mm
Configuration	
Emulation	None
Print speed	4 in/sec
Cutter	Not installed
Label taken sensor	Not installed

Setup Parameters

Serial Communication

The serial communication parameters control the communication between the printer and the connected computer or other devices on the serial port.



Note: The serial communication parameters have no effect on parallel or EasyLAN communications.

Make sure the printer's communication parameters match the setup of the connected device or vice versa. If the setup of the printer and the setup of the host do not match, the response from the printer to host will be garbled.

Baud Rate

The baud rate is the transmission speed in bits per second. There are 8 options:

- 1200
- 2400
- 4800
- 9600 (default)
- 19200
- 38400
- 57600
- 115200

Character Length

The character length specifies the number of bits that will define a character.

- 7 Characters ASCII 000 to 127 decimal
- 8 Characters ASCII 000 to 255 decimal (default)

Parity

The parity decides how the firmware will check for transmission errors. There are four options:

- None(default)
- Even
- Odd
- Space

Stop Bits

The number of stop bits specifies how many bits will define the end of a character. There are two options:

- 1 (default)
- 2

Protocol

XON/XOFF (default)

In the XON/XOFF protocol, data flow control is achieved by using XON (DC1) and XOFF (DC3) characters. Message blocks are **not** required to be bracketed by the Start of Text (STX) and End of Text (ETX) characters. However, at power up or after a reset all characters except ENQ or VT will be ignored until an STX is detected. The message length in this protocol is unrestricted. That is, the printer processes information as it is being downloaded and stops when there is no more information.

XON/XOFF protocol conforms to generally accepted industry standards. No end-of-message response is sent to the host other than XOFF. An XON will be sent on power up.

Since DC1 and DC3 are used for data flow control, the printer status characters are different than those of the Standard Protocol. If the host ignores the printer's XOFF, the printer will resend an XOFF after receiving every 15 characters from the host.

<i>Condition</i>	<i>Character</i>
Buffer already full	GS
Printhead raised	US
Ribbon fault	US
No label stock	EM
Buffer now full	DC4
Printhead hot	SI
Label at strip pin	FS
Label skipping	DC2
Printing	DC2

Intermec Standard Protocol

The Intermec Printer Standard Protocol is a half-duplex protocol. All data transmissions to the printer consist of status inquiry (ENQ), status dump (VT), or message blocks. Each message block starts with the Start of Text (STX) character and ends with the End of Text (ETX) character. Each message block must be 255 characters or less, including the STX and ETX characters. The printer responds to each status inquiry or message block with the printer status. The host should check the printer status before downloading a message block to the printer. ENQ causes the printer to transmit its highest priority status, while VT instructs the printer to transmit all status that applies in the order of their priority. The possible printer status in descending priorities are

<i>Condition</i>	<i>Character</i>
Buffer already full	GS
Printhead raised	US
Ribbon fault	US
No label stock	EM
Buffer now full	DC3
Printhead hot	SI
Label at strip pin	FS
Label skipping	DC1
Ready	DC1
Printing	DC1

Test/Service

Testprint

This part of the Setup Mode allows you to print various types of test labels. Go to the desired option and press <Enter>. The printer will start printing the test label or labels. Press the <Feed/Pause> button to hold the printing temporarily. To resume printing, press the <Feed/Pause> button again. The following options are available:

Configuration

Select between software (SW), hardware (HW), and network.

The Software Configuration Label contains:

- Current configuration parameters stored in the printer's memory
- Defined pages
- Defined formats
- Defined graphics
- Defined fonts
- Any installed printer options

The Hardware Configuration Label contains:

- Printer memory information
- Printer mileage
- Printhead settings
- Firmware checksum, program, and version number

The Network Configuration Label contains:

- WINS Name
- MAC Address
- IP Selection
- IP Address
- Netmask
- Default Router
- Name Server
- Mail Server
- Primary WINS Server
- Secondary WINS Server
- Network Statistics

Test Labels

This option has two choices, Pitch and Print Quality.

- The Pitch label contains an even pattern of small dots that reveals failing printhead dots and variations of printout darkness because of uneven printhead pressure or bad energy regulation to the printhead.
- The Print Quality label contains number of bar codes with different characteristics and useful information on printer model, program version, print speed, and media sensitivity setup.

Format

The Format Label contains a single format that you can use to evaluate the print quality of a particular format. This option prints labels for all the formats stored in the printer's memory.

Page

The Page Label tests the ability of the printer to receive and print single or multiple pages of label data that is sent from the host. This option prints labels for all the pages stored in the printer's memory.

UDC

The UDC Label tests the ability of the printer to receive and print single or multiple user-defined characters (bitmap graphics) that are sent from the host. This option prints labels for all the UDCs stored in the printer's memory.

Font

The Font Label contains all the characters in a single font. This option prints labels for all the user-defined fonts (UDF) stored in the printer's memory.

Data Dump

If data dump is enabled by selecting the "Yes" option, the printer prints all data and protocol characters received on the serial port. An ASCII and hexadecimal representation of each character is printed.

Memory Reset

There are two options. The memory will be reset to factory default as soon as an option has been selected and <Enter> is pressed. Select between "All", which resets the entire memory and "Configuration" which just resets the configuration part of the memory.

LSS Test

Refer to Chapter 11 "Label Stop Sensor" for description.

Media

The media parameters tell the firmware the characteristics of the media that will be used, so the printout will be positioned correctly and get the best quality possible.

Media Type

The Media Type parameters control how the label stop sensor (LSS) and the media feed work. There are three media type options:

- Gap is used for adhesive labels mounted on liner (backing paper) or continuous paper stock with detection slots. Default.
- Mark is used for labels, tickets, or strip provided with black marks at the back.
- Continuous is used for continuous stock without any detection slots or black marks.

Paper Type

The Paper Type parameters control how the transfer ribbon mechanism and the ribbon sensor work. There are two paper type options:

- DT (Direct Thermal) is used for heat-sensitive media without any need for a thermal transfer ribbon. Default.
- TTR (Thermal Transfer) is used for non heat-sensitive receiving face materials in combination with a thermal transfer ribbon.

Label Length Dots

The Label Length setup specifies the length in dots of each copy along the media feed direction (X-coordinate). This is used for “label-out” detection.

Sensitivity (Media Sensitivity Number)

This setup parameter specifies the characteristics of the direct thermal media or combination of receiving face material and thermal transfer ribbon, so the printer’s firmware can optimize the heating of the printhead and the print speed. Standard supplies from Intermec are labeled with a 3-digit media sensitivity number (see Appendix D) which is used to specify the media grade. The media sensitivity number can also be changed using PrintSet, third-party software, or an IPL command (`<SI>gn [, m]`). Default is 420 for direct thermal printing and 567 for thermal transfer printing.

Darkness

Use this parameter to make minor adjustments of the blackness in the printout, for example to adapt the printer to variations in quality between different batches of the same media quality. The value can be set within the range -10% to +10% where -10 is the lightest and 10 is the darkest. Default value is 0%.

Label Rest Point

Specifies where labels stop for removal. Use this for peel-off (self-strip) applications. Allowed range is -30 (furthest back) to 30 (furthest forward). Default is 0. Also available as an IPL command (`<SI>fn`).

Form Adj Dots X

Specifies where the X-position of the origin should be placed on the label. Allowed range is -30 (closest to the leading edge) to 30 (furthest from the leading edge). Default is 0.

Form Adj Dots Y

Specifies where the Y-position of the origin should be placed on the label. Allowed range is -30 (closest to the center section) to 30 (furthest from the center section). Default is 0.

Ribbon Low

Specifies the value in millimeters of the ribbon supply roll for the ribbon sensor. When the diameter of remaining ribbon supply roll reaches the set value, an SNMP trap is sent to the printer's home page, provided the printer has an optional EasyLAN connection. Range: 0-80 with preset values at an interval of 5. A value larger than 80 sets the ribbon sensor to 0. Default value: 0.

The ribbon low sensor can also be set using an IPL command:

```
<STX><SI>kn<ETX>
```

Paper Low (option)

Specifies the diameter in millimeters of the media supply roll for the paper sensor. When the diameter of remaining media supply reaches the set value, an SNMP trap is sent to the printer's home page, provided the printer has an optional EasyLAN connection. Range: 0-150 with preset values at an interval of 10. A value larger than 150 sets the paper sensor to 0. Default value: 0.

The ribbon low sensor can also be set using an IPL command:

```
<STX><SI>jn<ETX>
```

Configuration

Emulation

Emulation mode lets you print bar code labels that were originally designed on an 86XX printer in multiples of 10 or 15 mil. When the printer is working in emulation mode, not all IPL commands are supported. For a complete list of commands available during emulation mode, see the latest version of the *IPL Programming, Reference Manual* (P/N 066396-XXX).

To return from emulation mode, select emulation “none” (default).

Print Speed

You can select the print speed from 4 in./sec. (100 mm/sec.) to 8 in./sec. (200 mm/sec.) with an interval of 1 in./sec. The higher the print speed, the more wear on the printhead, so do not use a higher print speed than necessary. Some direct thermal media or ribbon/media combinations may not allow the highest alternatives without the printout quality being adversely affected.

Cutter (option)

By default, “Not Installed” is displayed. If a cutter is installed, you must manually indicate that condition to the firmware by selecting either “Enable” or “Disable.” Once you have done that, you can **also** use IPL commands to enable or disable the cutter:

<code><STX>R<ETX></code>	enter print/configuration mode
<code><STX>SIc0<ETX></code>	Disable cutter
<code><STX>SIc1<ETX></code>	Enable cutter

Label Taken Sensor (option)

To make the printer work in self-strip mode, that is, waiting for a label to be removed before the next label is printed, the self-strip mode must be enabled. This can also be done by executing the following commands:

<code><STX>R<ETX></code>	enter print/configuration mode
<code><STX><SI>t0<ETX></code>	Disable self-strip
<code><STX><SI>t1<ETX></code>	Enable self-strip

If the label taken sensor does not work properly, the sensitivity can be calibrated in the Setup Mode. Select “LTS Calibration” and follow the instructions in the display. Make sure that no direct sunlight or interior lighting interferes with the label taken sensor.

Returning to Factory Default Setup

There are two ways to return to the factory default setup of the printer:

- A** Insert a special CompactFlash memory card and restart the printer.
- B** Using the printer's built-in keyboard.

To reset the printer using the keyboard, do like this:

- 1 Lift the printhead.
- 2 Switch on the power to the printer and press the <i> key and wait until the printer beeps.
- 3 Swiftly press the following keys:
<▼> → <▲/Esc> → <▲/Esc> → <◀>
- 4 The following message will be displayed:

```
Factory Default?  
Enter=Yes ESC=No
```

- 5 Within 10 seconds, press <Enter> to reset the printer to factory default. The parameters will be reset and the printer will continue the normal startup.

If you press <▲/Esc> or wait until the 10 seconds timeout has passed, the normal startup will continue without any reset being performed.



Note: The factory default will remove all files used to store settings. It will not reset settings that already has been read when the files are removed. This means that EasyLAN Wireless settings (SSID, keys, etc.) will retain their values from the previous start. However, the next reboot will reset them to factory default.









7 Setup Mode

This chapter describes how to navigate in the setup mode, and provides overviews of the Setup Mode.

Navigating in Setup Mode

Enter the Setup Mode by pressing the <Setup> key on the printer's front panel. While going through the setup procedure, you are guided by texts in the printer's display. You can navigate between setup menus, acknowledge displayed values, select or enter new values, etc. by using the keys on the printer's keyboard.

	Move one step back on the same level.
	Move up one level and escape without changing the setting.
	Move forward on the same level.
	Move down one level.
	Acknowledge and move to next menu.
	Exit the Setup Mode. Can be used anywhere in Setup Mode.

The Setup Mode is organized as an endless loop, from which you can select a number of sub-categories. At startup, the firmware determines if options such as a label taken sensor, a cutter, or an interface board is installed in the printer. Only installed options are shown in the Setup Mode.

The diagram below shows the options in the main loop. Detailed overviews are shown on the pages that follow.

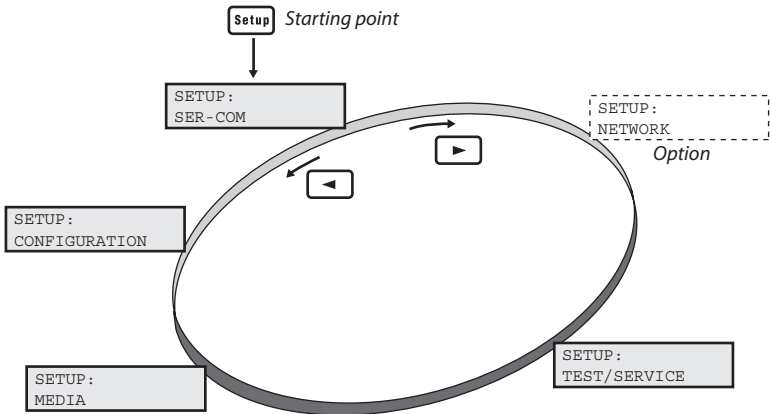

Setup Mode; Serial Communication

(IPL v2.30)

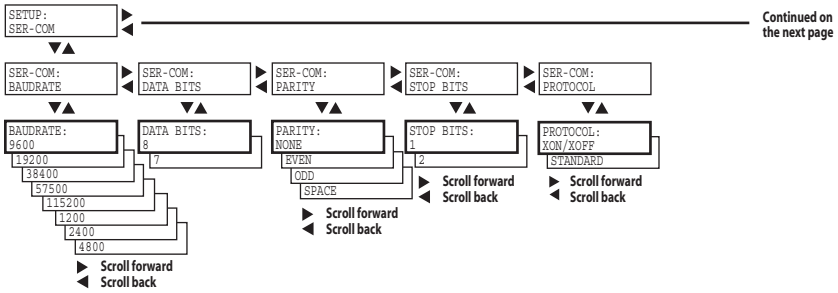

Legend:

Dotted boxes and lines indicate options.

Thick boxes indicates default options.

Values inside brackets indicate default settings.

Setup Mode; Network (option)

(IPL v2.30)

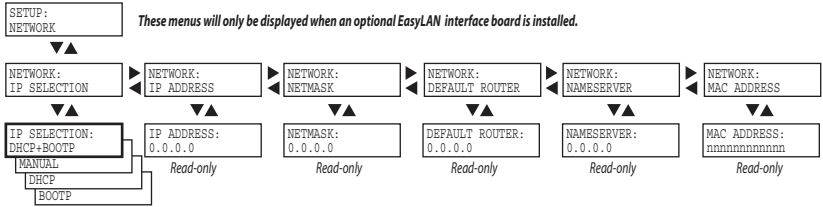

Setup Mode; Test/Service

(IPL v2.30)

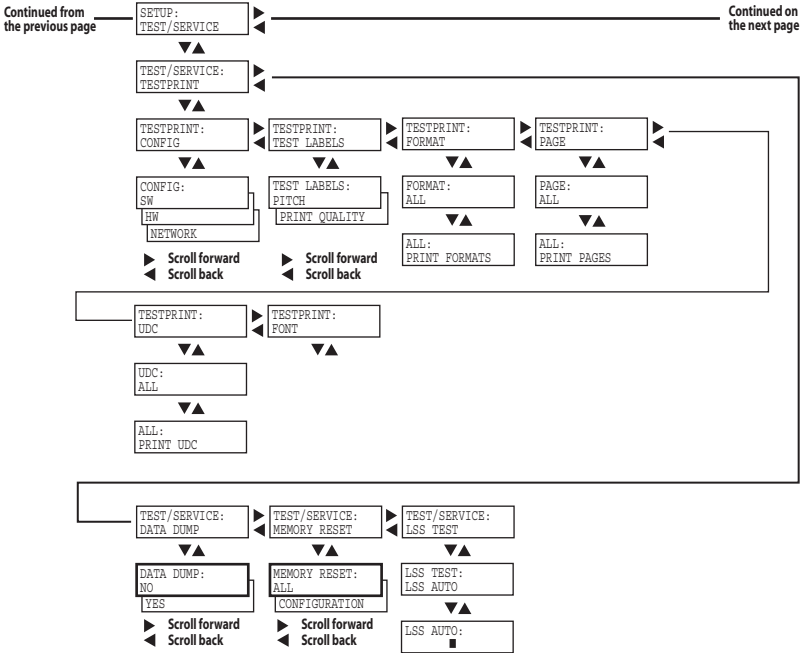

Setup Mode; Media

(IPL v2.30)

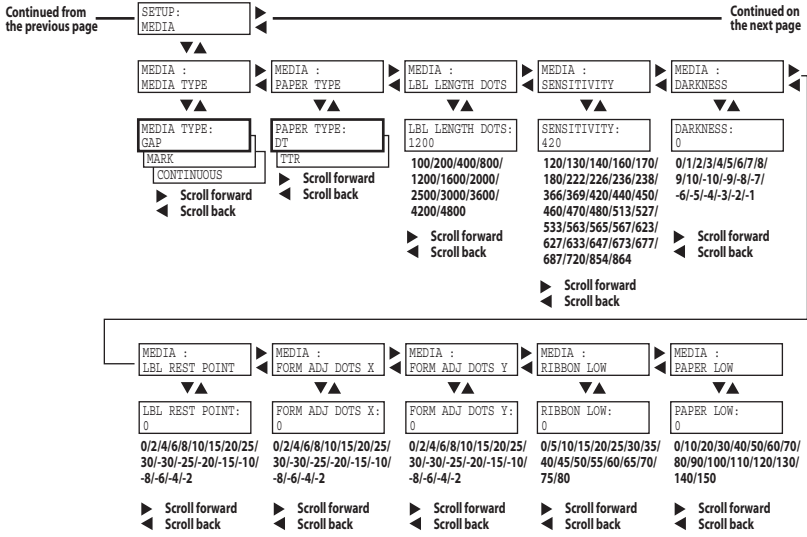

Setup Mode; Configuration

(IPL v2.30)

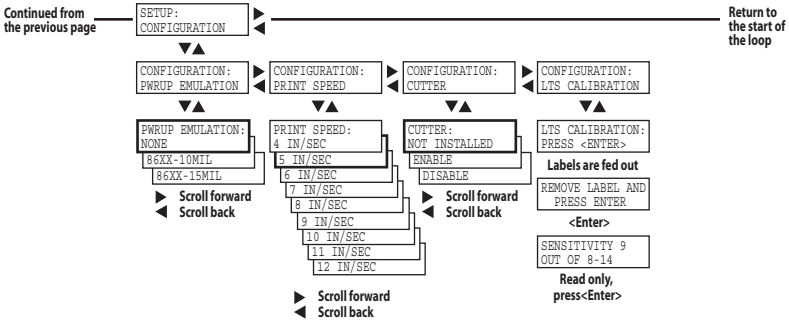

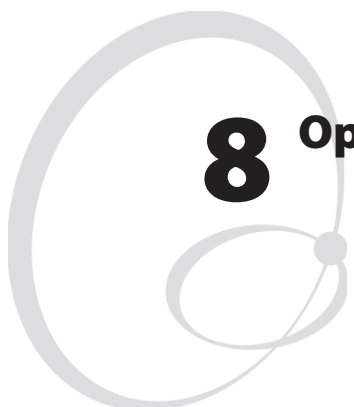
A decorative graphic consisting of two overlapping circles. The larger circle is on the left and the smaller one is on the right, partially overlapping the larger one. The circles are light gray and have a thin, slightly irregular border.

8 Options

This chapter describes the options available for the EasyCoder PM4i printer. The options can be factory installed, field-installed by an authorized service technician, or in some cases installed by the operator.

Introduction

The EasyCoder PM4i provides a high degree of flexibility because it has a modular design. By adding options to the basic printer, the EasyCoder PM4i can be adapted for a variety of applications. Most options should be installed by an authorized service technician or are only available as factory-installed options.

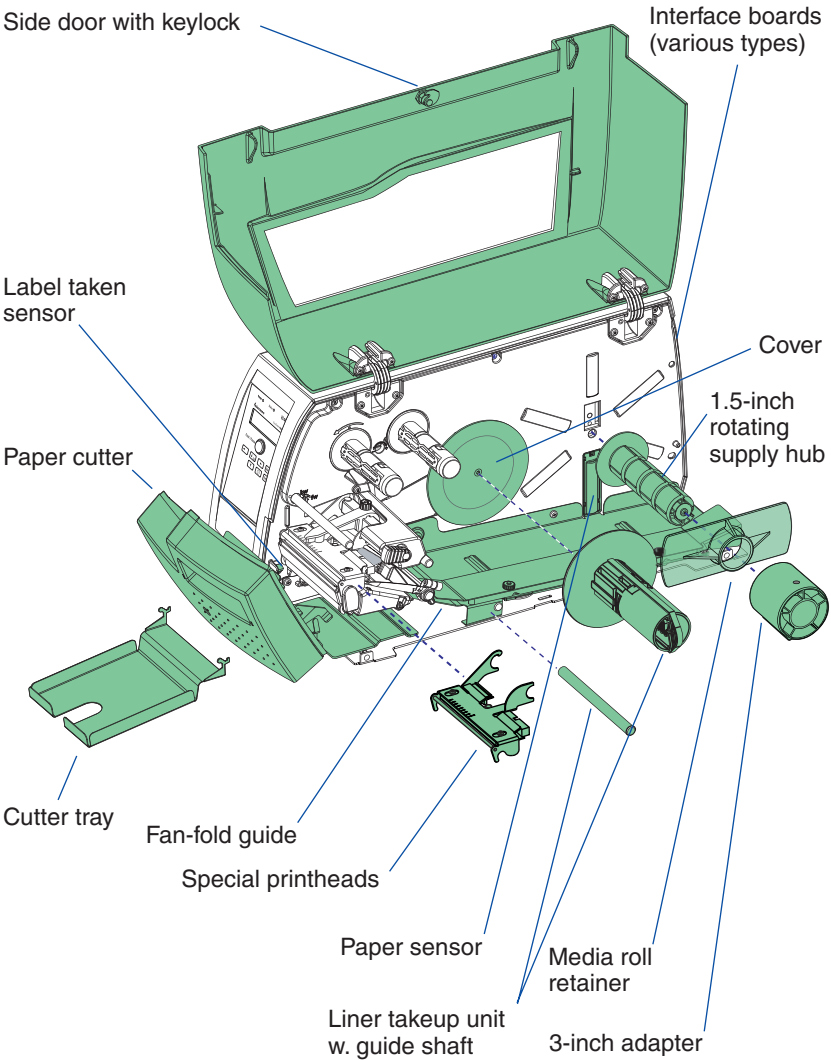

Integral Liner Takeup Unit

The integral liner takeup unit is an optional device for peel-off (self-strip) operation, which means that the labels are separated from a liner (backing paper) after printing and the liner is wound up on an internal hub. The unit also includes a guide shaft. Peel-off cannot be combined with an internal fan-fold guide. Also see Chapter 4, "Media Load, Peel-Off."

Paper Cutter

The paper cutter is designed to cut off continuous paper-based stock or liner between labels. The cut-off labels, tickets, or tags can be collected on an optional tray. Also see Chapter 4, "Media Load, Cut-Off."

Media Supply Hub

The rotating media supply hub is designed to fit media roll cores with an internal diameter of 38-40 mm (1.5 inch).

Paper Sensor

The paper sensor is fitted inside a plastic cover in the center section below the media supply hub. It can only be used with a rotating media supply hub and detects when the remaining media supply has reached a preset minimum diameter, as specified in the Setup Mode.

Media Roll Retainer

The retainer is intended to keep large media rolls in place when using a rotating media supply hub. It restricts the maximum media width to 100 mm (3.9 inches). Installed by the operator.

3-inch Adapter

The 3-inch/76 mm adapter is used with a rotating media supply hub and makes it possible to use media rolls with 3 inch/76 mm inner diameter cores. The adapter is pressed onto the hub and secured by a screw. Not used with a media supply roll post. Installed by the operator.

Label Taken Sensor

The Label Taken Sensor (LTS) is a photoelectric sensor that enables the printer's firmware to detect if the latest printed label, ticket, tag, etc. has been removed before printing another copy. The LTS cannot be used in connection with a paper cutter.

Internal Fan-Fold Guide

This guide facilitates media load from an external supply to the rear of the printer and provides superior guiding of the media. It can not be used in connection with peel-off (self-strip) operation and cannot be combined with a label slack absorber, which may restrict the maximum print speed somewhat.

Side Door with Keylock

If the media is valuable or sensitive, such as tickets, you can install a side door that can be locked with a key. Can be installed by the operator.

Thick Media Printhead

As standard, the printer is fitted with an 8 dots/mm (203.2 dots/inch) thermal printhead for a media thickness of max. 175 μ m (7 mils). There is also an optional printhead for 170-220 μ m (6.6-8.7 mils) media thickness. The printhead can easily be replaced or exchanged by the operator as described in Chapter 11.

Interface Boards

A number of interface boards are available for use with the EasyCoder PM4i printer. The interface boards are either factory-fitted or can easily be fitted by an authorized service technician.

The EasyCoder PM4i can accommodate one EasyLAN interface board plus one IEEE 1284 Parallel Interface Board.

EasyLAN boards:

- EasyLAN Ethernet Interface
- EasyLAN Wireless Interface

A decorative graphic consisting of two overlapping circles. The larger circle is light gray and partially encloses the smaller circle. The smaller circle is also light gray and has a small dark gray dot at its rightmost point. The number '9' is positioned to the left of the text 'Troubleshooting', which is in a bold, black, sans-serif font.

9 Troubleshooting

This chapter describes how the Intermec Readiness Indicators work. It also lists various possible cases of inferior printout quality, describes possible causes, and suggests remedies.

Intermec Readiness Indicator

The readiness of the printer, individually or as a part of a solution, is indicated by the blue Intermec Readiness Indicator (IRI).

If the IRI blinks or is switched off, the printer is not ready. Further information can be obtained in the display window by pressing the <i> key. In case of several errors or similar conditions occurring simultaneously, only the most significant error is displayed. Once this error has been cleared, next remaining error is displayed.

Provided the printer is connected to a network, all conditions that prevents printing are reported to the Easy ADC Console. The Easy ADC Console is a PC-based software which allows a supervisor to monitor all connected devices that have an Intermec Readiness Indicator, including handheld computers, access points, and printers.

Display Messages and LED Indications

Error/Event	IRI	Error Message	Comment
Operational	On		No error
Out of paper	Blink	PAPER OUT	
Out of transfer ribbon	Blink	RIBBON OUT	
Transfer ribbon is installed	Blink	RIBBON FITTED	
Head lifted	Blink	PRINTHEAD UP	
Cutter error1	Blink	OPEN&SHUT CUTTER	
Cutter error2	Blink	OPEN&SHUT CUTTER	
Cutter error3	Blink	OPEN&SHUT CUTTER	
Lss too high	Blink	PAPER FAULT	
Lss too low	Blink	PAPER FAULT	
Testfeed not done	Blink	PAPER FAULT	
Press feed not done	Blink	PRESS FEED	
Pause mode entered	Blink	PAUSED	
Setup mode entered	Blink		Incl. interactive setup
IP link error	Blink		See note 1, 2, and 3
IP configuration error	Blink		See note 1, 3, and 4
Printhead not found	Off	NO PRINTHEAD	
Rebooted	Off		
Initializing	Off		Set at startup until operational
Printer crash	Off		See note 3 and 5
Printer turned off	Off		
Maintenance	Off		Set when upgrading
Power supply Over temperature	Off	PSU OVER TEMP	
Printhead hot	Off	PRINTHEAD HOT	See note 6

Chapter 9—Troubleshooting

Note 1: This is only applicable for printers equipped with an EasyLAN interface.





Note 2: A printer that is equipped with an EasyLAN interface, but is not connected to a network, will have a blinking IRI. To avoid this, the user can set “IP SELECTION” to “MANUAL” and “IP ADDRESS” to “0.0.0.0”. This will indicate that the user does not regard the lack of network connection as an error.

Note 3: No trap can be sent when this error/event occurs.



Note 4: This error indicates that the printer has not received an IP address. It is only applicable for printers with IP SELECTION set to DHCP and/or BOOTP.

Note 5: At most, but not all, printer crashes, the console is reset. This will make the IRI go off.

Note 6: If the printhead temperature raises above 100°C (212°F), an error occurs and the printing will be paused until the printhead has cooled off. Meanwhile, the printer is able to receive commands and data until the buffer is filled. The printing is automatically resumed when the printhead temperature has reached 85°C (185°F).

Symptom	Possible Cause	Remedy	Refer to
Overall weak print-out	Wrong media grade	Change parameter	Chapter 6, Appendix D
	Contrast value too low	Change parameter	Chapter 6
	Printhead pressure too low	Adjust	Chapter 11
	Worn printhead	Replace printhead	Chapter 10
	Wrong printhead voltage	Replace CPU board	 Call Service
Printout weaker on one side	Uneven printhead pressure	Adjust arm alignment	Chapter 11
Weak spots	Foreign particles on media	Clean or replace	Chapters 4 & 5
	Media/ribbon don't match	Change to matching media	Chapter 6
	Poor media or ribbon quality	Select a better brand of media/ribbon	Appendix D
	Worn printhead	Replace printhead	Chapter 10
	Worn platen roller	Check/replace	 Call Service
Overall dark print-out	Wrong media grade	Change parameter	Chapter 6, Appendix D
	Contrast value too high	Change parameter	Chapter 6
	Printhead pressure too high	Adjust	Chapter 11
	Wrong printhead voltage	Replace CPU board	 Call Service
	Excessive bleeding	Wrong media grade	Change parameter
Contrast value too high		Change parameter	Chapter 6
Printhead pressure too high		Adjust	Chapter 11
Faulty energy control		Replace CPU board	 Call Service
Dark lines along media path		Foreign objects on printhead	Clean printhead

Chapter 9—Troubleshooting

White vertical lines	Printhead dirty	Clean printhead	Chapter 10
	Missing printhead dots	Replace printhead	Chapter 10
Large part of dot line missing	Failing printhead	Replace printhead	Chapter 11
	Failing strobe signal	Check CPU-board	 Call Service
Printout missing along inner edge	Bad media alignment	Adjust	Chapter 4
	Small core & supply post in upper pos.	Move post to lower pos.	Chapter 2
	X-start parameter value too low	Increase	Chapter 6
Transfer ribbon breaks	Ribbon not fitted correctly	Reload ribbon	Chapter 5
	Wrong media grade	Change parameter, then clean printhead	Chapter 6, Chapter 10
	Bad energy control	Adjust	 Call Service
Transfer ribbon wrinkles	Faulty ribbon break shaft adjustment	Adjust	Chapter 11
	Incorrect edge guide adjustment	Adjust	Chapter 4
	Too strong printhead pressure	Adjust	Chapter 11
No thermal transfer printout	Ink-coated side does not face media	Reload ribbon	Chapter 5
Media feed not working properly	Changed media characteristics	Press the Print button	Chapter 4
	Wrong label rest dots parameter	Check/change	Chapter 6
	Wrong Media Type parameter	Check/change	Chapter 6
	Wrong LSS position	Check/change	Chapter 11
	Dirty sensors	Clean media guides	Chapter 10
	Faulty sensors	Replace	 Call Service
Compressed text or bar code	Too high print speed for large media roll	Lower print speed	Chapter 6

10 Maintenance

This chapter describes how the operator can maintain the printer. Regular maintenance is important for the printout quality and for the life of the printhead. The chapter covers the following topics:

- Printhead cleaning
- External cleaning
- Cleaning the media guides
- Printhead replacement
- Media jams



When cleaning or replacing the printhead, take ample precautions to avoid electrostatic discharges.

Printhead Cleaning

Cleaning the printhead on a regular basis is important for the life of the printhead and for the printout quality. You should clean the printhead each time you replace the media. This section describes how to clean the printhead using cleaning cards. If additional cleaning is required, for example removing adhesive residue from the platen roller or tear bar, use a cotton swab moistened with isopropyl alcohol.



Isopropyl alcohol [(CH₃)₂CHOH; CAS 67-63-0] is a highly flammable, moderately toxic, and mildly irritating substance.

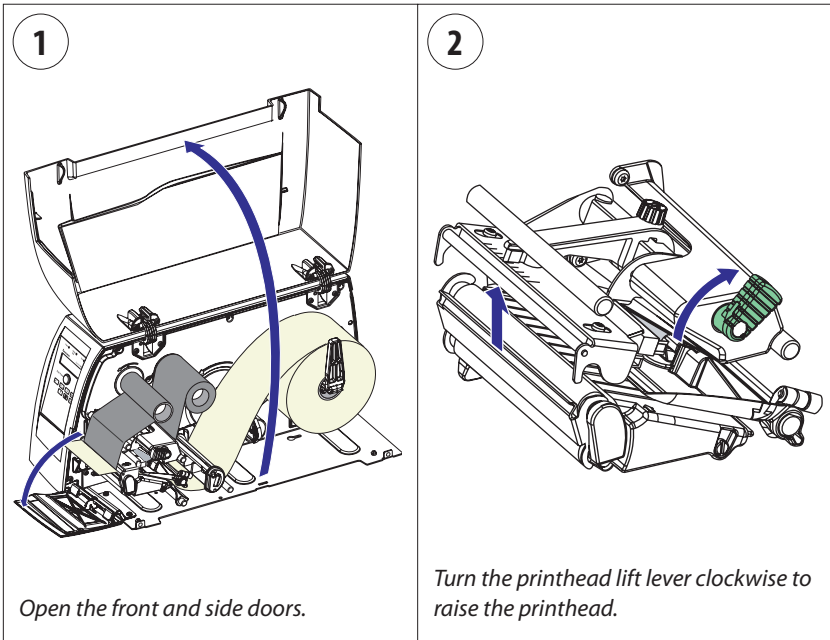

Printhead Cleaning, cont.

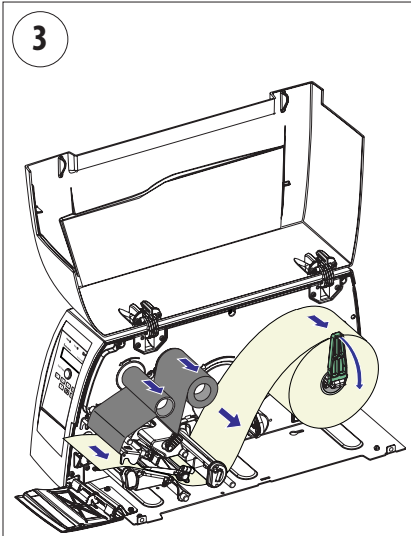

Remove any media and transfer ribbon.

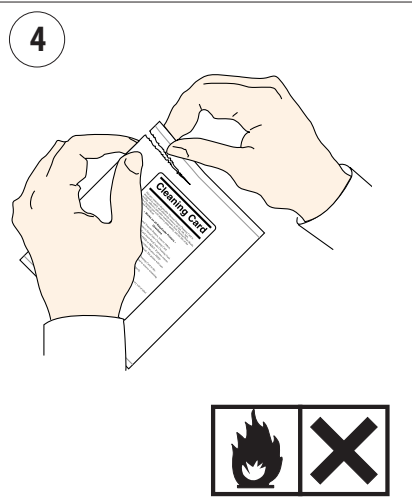

Open the cleaning card envelope and pull out the cleaning card. Read the warning text.

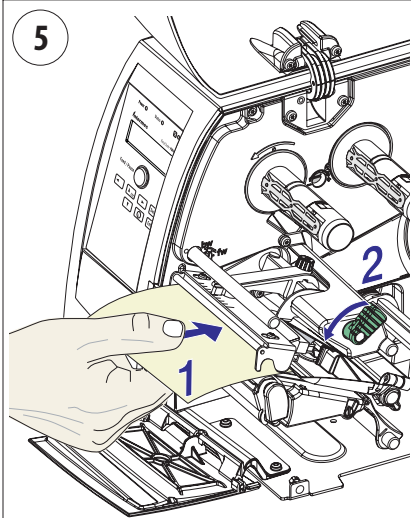

Insert most of the cleaning card under the printhead (1). Engage the printhead (2).

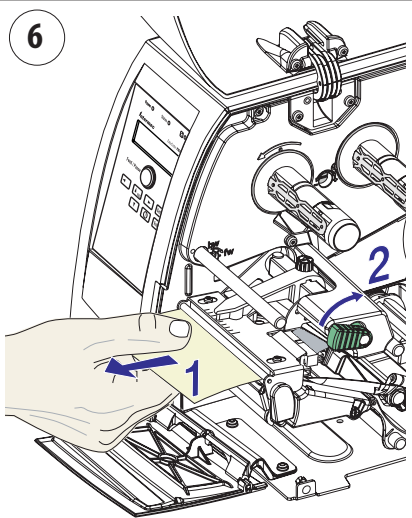

Pull out the cleaning card (1) and raise the printhead (2).

Printhead Cleaning, cont.

7

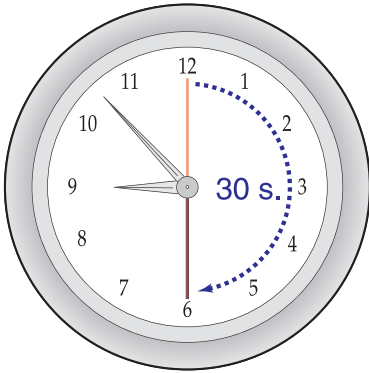

Wait for approx. 30 seconds to allow the cleaning fluid to dissolve the residue.

8

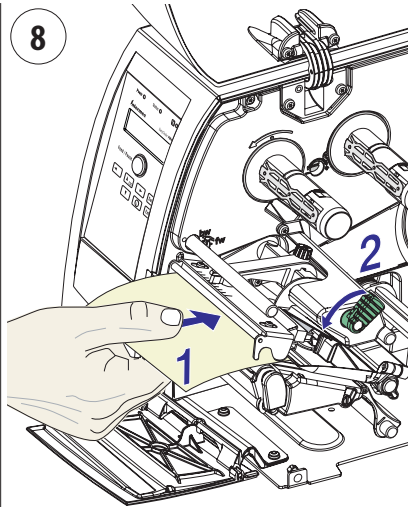

Insert most of the cleaning card under the printhead again (1). Engage the printhead (2).

9

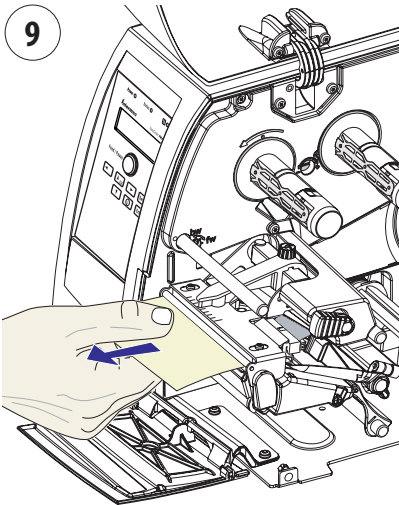

Pull out the cleaning card. If necessary, repeat the process with a fresh cleaning card.

10

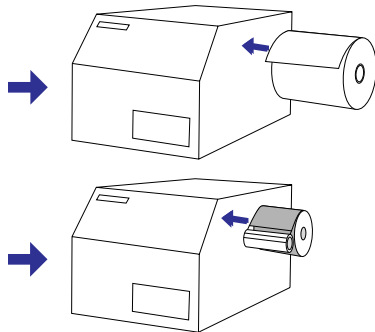

Allow the cleaned parts to dry before loading any media (and ribbon).

External Cleaning

1

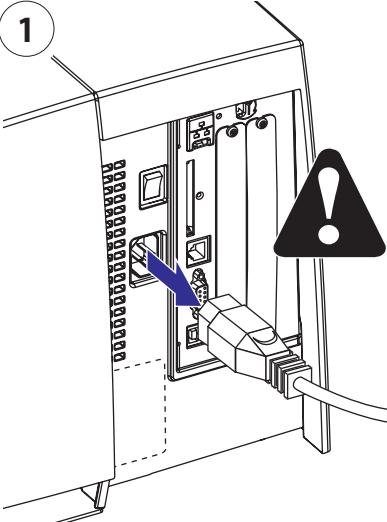

Always remove the power cord before cleaning!

2

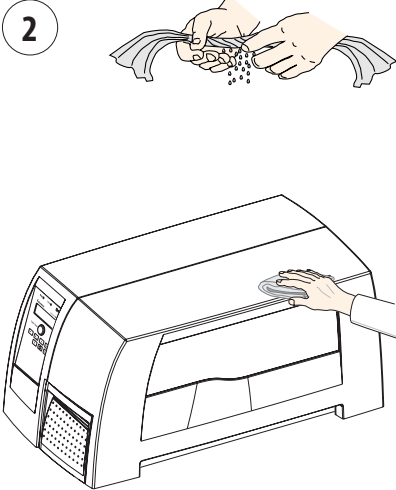

Wipe external surfaces with a soft cloth slightly moistened with water or a mild detergent.

3

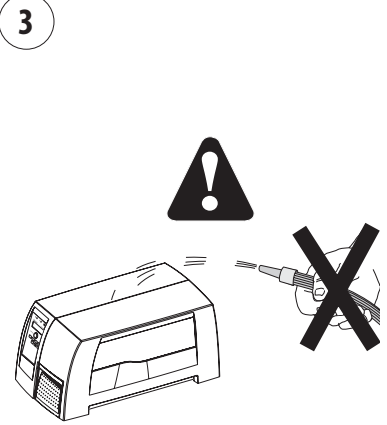

Never spray the printer. Protect it from water when cleaning the premises.

4

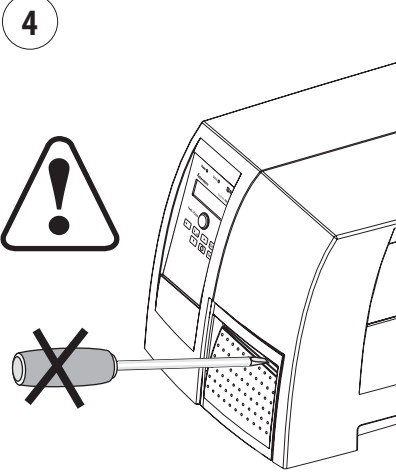

Never use any sharp tools for removing stuck labels. The printhead and rollers are delicate.

Cleaning the Media Guides

Both parts of the label stop sensor, which controls the media feed, are covered by plastic guides. The guides are transparent to allow the light to pass between the two parts of the label stop sensor. These areas must be kept clean from dust, stuck labels, and adhesive residue.

If the printer starts to feed our labels in an unexpected way, pull out the upper guide as described below and check for any object that may block the beam of light (dust, stuck labels, adhesive residue, etc.). If necessary, clean the guides using a cleaning card or a soft cloth soaked with isopropyl alcohol. Do not use any other type of chemical. Be careful not to scratch the guides.



Warning

Isopropyl alcohol [(CH₃)₂CHOH; CAS 67-63-0] is a highly flammable, moderately toxic, and mildly irritating substance.

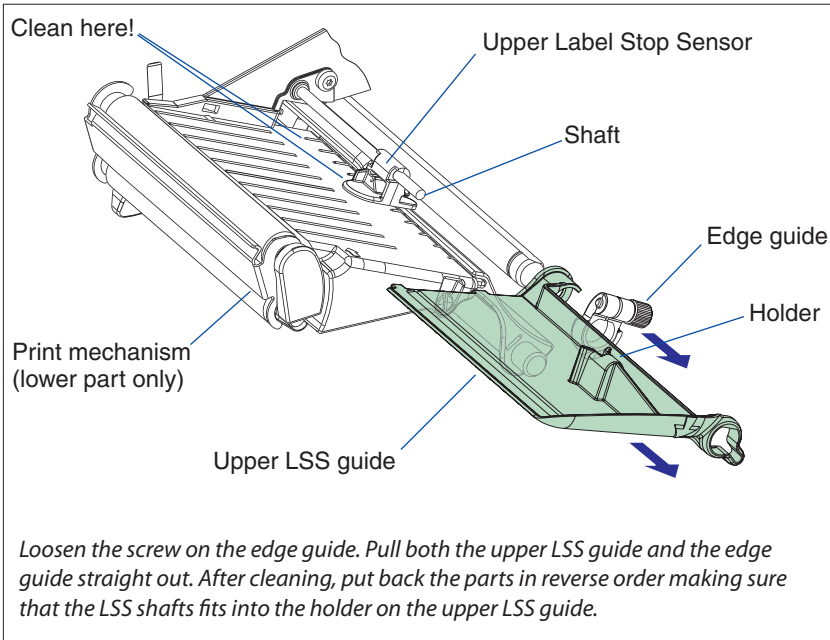

Printhead Replacement

The printhead is subject to wear both from the direct thermal media or ribbon and from the rapid heating and cooling process during printing. Thus, the printhead will require periodic replacement.

Time between printhead replacements depends on the print images, the type of direct thermal media or ribbon in use, the amount of energy to the printhead, the print speed, the ambient temperature, and several other factors.



While replacing the printhead, the power must be off. The firmware will not detect the new printhead resistance until the printer has been restarted.

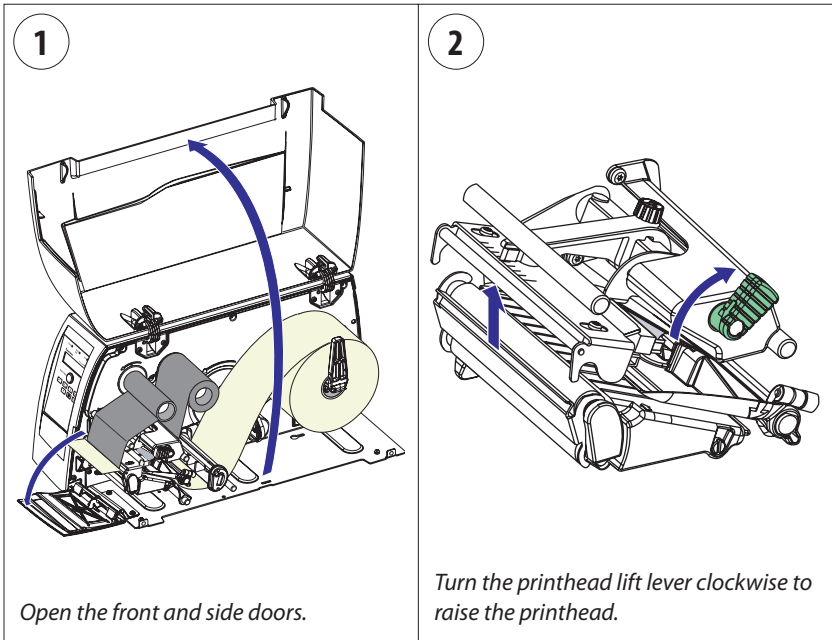

Printhead Replacement, cont.

3

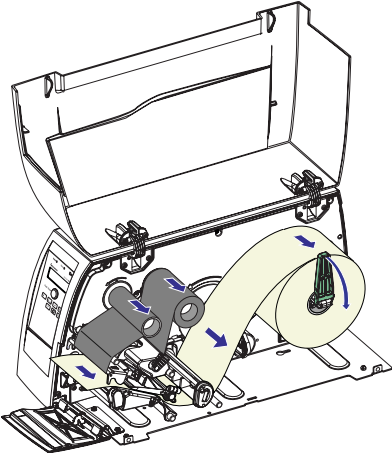

Remove any media and transfer ribbon.

4

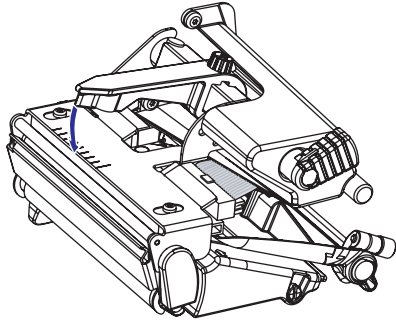

Pull the printhead bracket away from the magnet in the pressure arm.

5

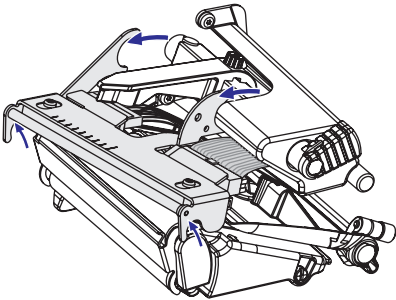

Disconnect the printhead bracket from the print mechanism as indicated by the arrows and pull out the printhead as far as the cables allow.

6

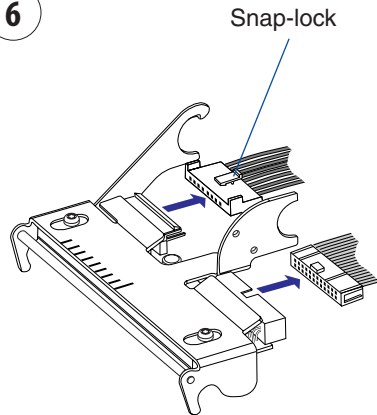

Disconnect the cables from the printhead. Note the snap-lock on the inner connector. Pull at the connectors—not at the cables!

Printhead Replacement, cont.

7

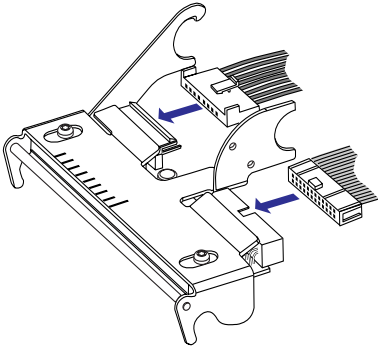

Connect the two cables to the replacement printhead.

8

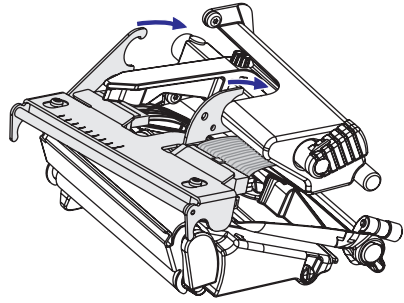

Put back the printhead in reverse order and check that the printhead cables run freely.

9

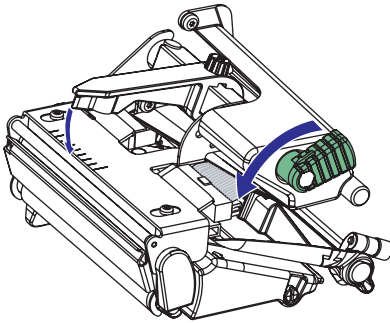

Turn the printhead lift lever counter-clockwise so the magnet engages the printhead bracket.

10

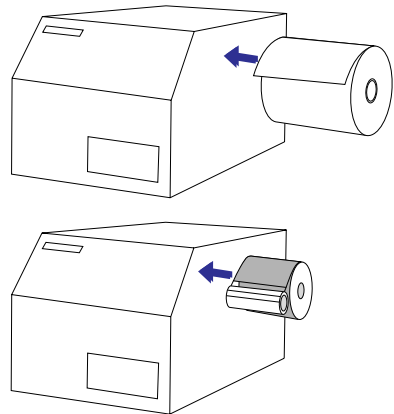

Load a new supply of media and ribbon, as described earlier in this manual.

Media Jams

Should a media jam occur in the print mechanism, proceed this way to clear it:

- Always switch off the power before starting to clear the jammed media.
- Raise the printhead and pull out the media.
- If the media has been wound up or has stuck on the platen roller, carefully remove it by hand without using any sharp tools that can damage the delicate platen roller or printhead. Avoid rotating the platen roller.



Caution

If you must pull away the media by force causing the platen roller to rotate, it is very important that the power has been off for a minute or more. If not, the electronics can be damaged beyond repair.

- Cut off any damaged or wrinkled part.
- Check if there is any adhesive somewhere in the print mechanism, clean using a cleaning card or cotton swab soaked in isopropyl alcohol.



Warning

Isopropyl alcohol [(CH₃)₂CHOH; CAS 67-63-0] is a highly flammable, moderately toxic, and mildly irritating substance.

- Reload the media as described in Chapter 4.
- Switch on the power.
- Readjust the media feed by pressing the <Feed/Pause> key.



11 Adjustments

This chapter describes how the operator can adjust the printer. The chapter covers the following topics:

- Narrow media adjustment
- Label stop sensor position adjustment
- Printhead pressure adjustment
- Ribbon break shaft adjustment

Narrow Media

The printer is factory-adjusted for full-size media width. When using media less than full width, it is recommended that you adjust the position of the pressure arm so it becomes centered with the media. Thereby, an even pressure across the media is obtained.

A poorly adjusted pressure arm may be detected by a weaker printout on either side of the media path.

To adjust the pressure arm, proceed as follows:

- Loosen the knurled nut that holds the pressure arm. Move the arm inwards or outwards until the arrow on the tip of the arm becomes centered with the media.

While moving the arm, push at the part where the screw is situated, not at the tip. If the arm is hard to move, lift the printhead and pull the printhead bracket free from the magnet in the arm.

- After having centered the arm, lock it by tightening the nut.
- Remember to adjust all edge guides too.

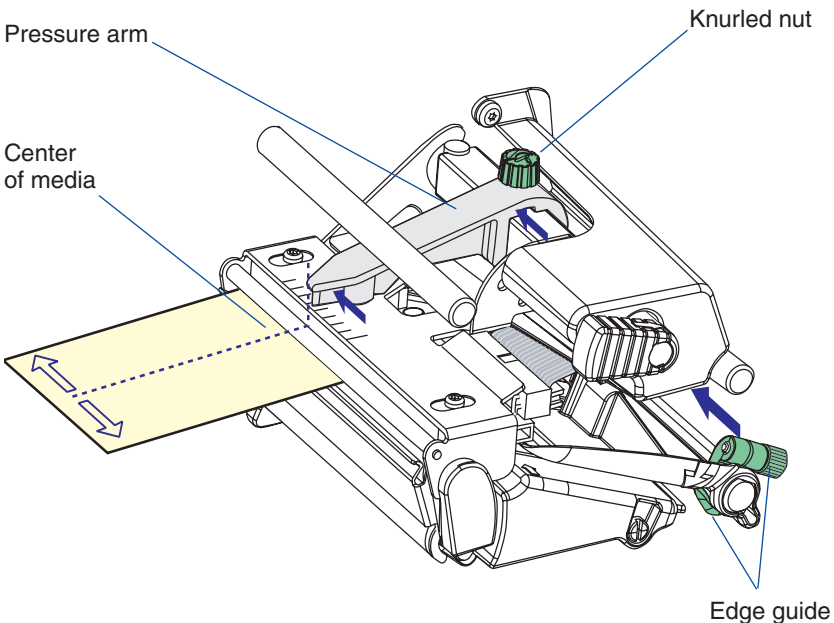

Label Stop Sensor

The label stop/black mark sensor (LSS) is a photoelectric sensor that controls the printer's media feed by detecting gaps between labels, or slots or black marks in continuous stock, depending on the printer's setup in regard of media type (see Chapter 6, "Setting Up the Printer"). An obvious prerequisite is that the LSS must be aligned with the gaps, slots, or black marks. If using irregularly shaped labels, align the LSS with the front tips of the labels.

The LSS can be moved laterally from the inner edge of the media path and 57 mm (2.24 inches) outwards, which corresponds to the center-line of full width media. There is one part of the sensor on top of the upper media guide and another part underneath the lower guide. Using a straight-slot screwdriver, turn the adjustment screw until the point of detection on the upper sensor becomes aligned with the center of the slots or marks in the media, when you look into the print mechanism from the front with the printhead lifted.

- Rotate the screw clockwise to move the sensor towards the center section.
- Rotate the screw counterclockwise to move the sensor outwards, away from the center section.

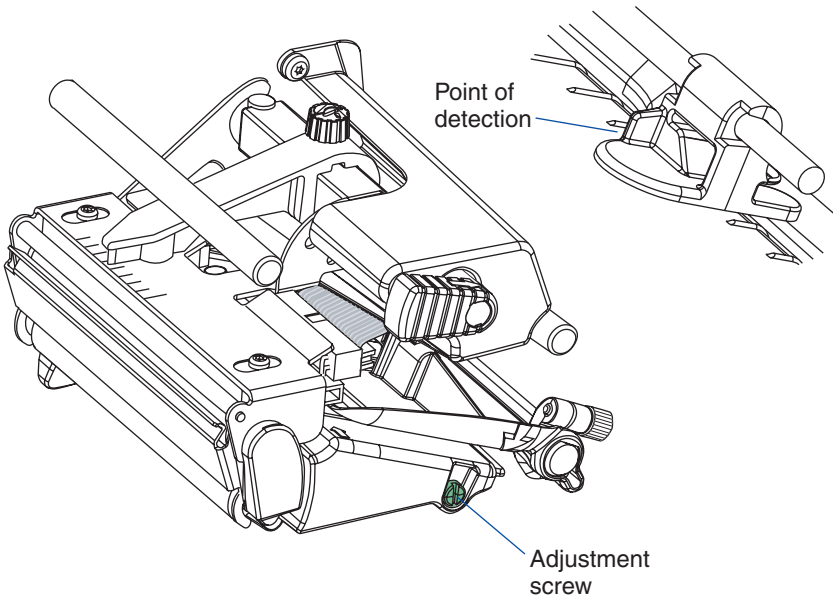

Chapter 11—Adjustments

In the Test/Service part of the Setup Mode, you can test the label stop sensor if you have a detection problem.

The menu only provides indications from the label stop sensor unit. The testing menu can determine if the sensor unit is not physically in position, is blocked by dust or stuck labels, or is defective in some way. Furthermore, this is an aid if media has detection complications.



Note: There is no way to adjust the LSS-function; the menus only indicate values obtained from the LSS.

- Check that the printer is set up for the type of media loaded in your printer (Setup Mode→Media→Media type→Gap, Mark, or Continuous).
- Lift and lower the printhead, then press the <Feed/Pause> key.
- Make sure that there is a label—not a gap or mark—at the LSS.
- Check that the media is routed as close to the center section as the guides allow.
- Enter the Setup Mode (see Chapter 7) and go to Setup Mode→Test/Service→LSS Test→LSS Auto.
- The menu should look like this with the cursor placed in the center:

LSS Auto

■

- **Gap detection:**
Lift the printhead and pull out the media slowly. When the LSS detects a gap or a detection slot, the cursor moves to the right.

LSS Auto

■

- **Mark detection:**
Lift the printhead and pull out the media slowly. When the LSS detects a black mark, the cursor moves to the left.

LSS Auto

■

- It is possible to refresh the centered cursor position by pressing the <▼> key.

- If the cursor behaves as described above, the LSS is working and is properly aligned with the gaps, slots, or black marks.
- If the cursor does not react on a gap, slot, or black mark, check this:
 - Is the LSS laterally aligned with the slots or black marks?
 - Are both the upper and lower part of the LSS aligned with each other?
 - Is the transfer ribbon properly loaded so it does not interfere with the LSS? (See Chapter 5.)
 - Are the LSS guides clean and free from stuck labels or other objects that will interfere with the light that goes from one part of the LSS to the other? If not, clean as described in Chapter 10.
 - Does the media have some kind of preprint that can disturb the detection?
 - Is there too little difference between the black marks and the surrounding areas?
 - Does the liner have too little transparency?
 - Does the LSS work with another type of media? (Remember to change the Media Type setup, lift and lower the printhead, and then press the <Feed/Pause> key.)

Printhead Pressure

The pressure of the thermal printhead against the direct thermal media is factory-adjusted. However, the use of thicker or thinner media than normal could require the printhead pressure to be readjusted.

Using a straight-slot screwdriver, turn the adjustment screw clockwise for more pressure (+) or counterclockwise for less pressure (-). Print a few labels, preferably test labels (see Chapter 6, “Setting Up the Printer”) and check the printout. Increased pressure generally gives a darker printout and vice versa. Repeat until the desired result is obtained.

To return to the factory setting, tighten the screw (+) as far as it goes and then loosen it (-) four full turns.



Do not use a higher printhead pressure than necessary, because it may increase the wear of the printhead and shorten its life.

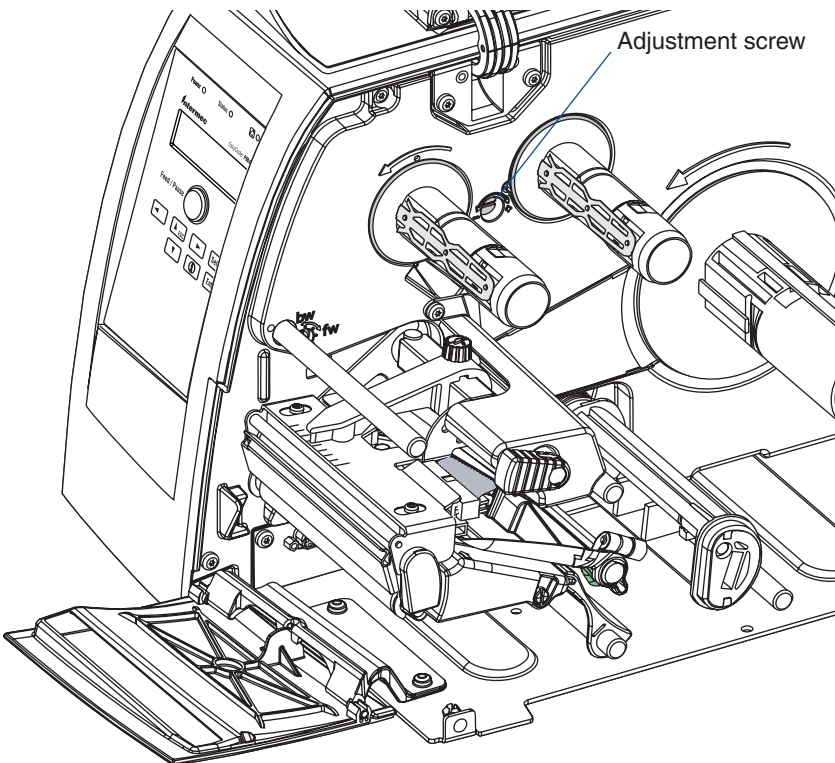

Ribbon Break Shaft

If ribbon wrinkling occurs, you may need to adjust the alignment of the front ribbon break shaft so that it runs parallel to the printhead and the ribbon supply and rewind hubs. The adjustment is done using a straight-slot screw that is located immediately behind the front ribbon break shaft.

- If the ribbon tends to slide outwards, turn the screw carefully clockwise (fw) to move the outer end of the break shaft forward.
- If the ribbon tends to slide inwards, turn the screw carefully counter-clockwise (bw) to move the outer end of the break shaft backward.



Caution

Before readjusting the break shaft, make sure that there is no other cause for the wrinkling of the ribbon. (See Chapter 9, “Troubleshooting.”)

Adjustment screw

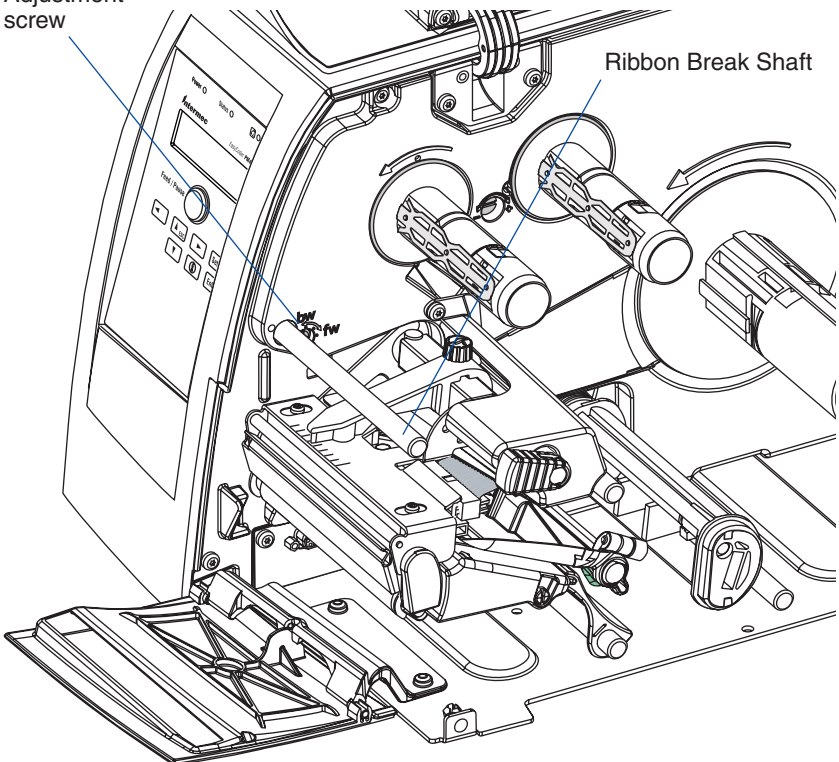

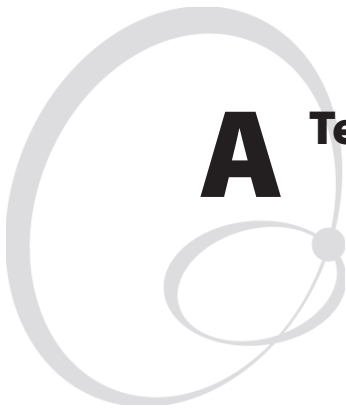
A decorative graphic consisting of two overlapping circles. The larger circle is on the left and the smaller one is on the right, partially overlapping the larger one. A small grey dot is located at the point where the two circles intersect.

A Technical Data

This appendix lists the technical data for the printer. Please note that Intermec reserves the right to change without prior notice and that this information does not represent a commitment on the part of Intermec.

Appendix A—Technical Data

Printing		
Print Technique	Direct Thermal and Thermal Transfer	
Printhead Resolution	8 dots/mm (203.2 dpi)	
Print Speed (variable)	100 to 200 mm/sec. (≈ 4 to 8 in./sec.)	
Print Width (max)	104 mm (4.095 in.)	
Print Length (max)	32767 dots = 409.5 cm (161.25 in.) ¹	
Media Width (min/max)	25 to 114.3 mm (1 to 4.5 in.)	
Media Roll Diameter (max)	213 mm (8.38 in.)	
Media Roll Core Diameter	38 to 40 mm (1.5 in.) or 76 mm (3 in.)	
Ribbon Width (min/max)	25 to 110 mm (1 to 4.33 in.)	
Ribbon Roll Diameter (outer), max.	82 mm (3.2 in.)	≈ 450 m (1475 ft) of ribbon
Ribbon Roll Core Diameter (inner)	25.4 mm (1.00 inches)	
Print Directions	4	
Modes of Operation		
Tear-Off (Straight-through)	Yes	
Peel-Off (Self-strip)	Option	
Cut-Off	Option	With cutter
Firmware		
Operating System	IPL v2.30	
Smooth Fonts	13 scaleable + 21 simulated bitmap	
Resident bar codes (std)	44	
Physical Measures		
Dimensions (W × L × H)	298 × 543 × 261 mm (11.7 × 21.4 × 10.3 in)	
Weight (excluding media)	13.5 kg (30 pounds)	
Ambient Operating Temperature	+5°C to +40°C (+41°F to +104°F)	
Humidity	20 to 80% non-condensing	
Electronics		
Microprocessor	32 bit RISC	
On-board Flash SIMMs	2 sockets for 4MB or 8MB each	Std. 1 x 4MB
On-board SDRAM SIMM	1 socket for 8MB or 16Mb	Std. 8MB

Power Supply		
AC Voltage	90 to 265 VAC, 45 to 65 Hz	
PFC Regulation	IEC 61000-3-2	
Power Consumption	Standby 15W; Peak 300W	
Sensors		
Label Gap/Black Mark/ Out of Media	Yes	Variable position
Printhead Lifted	Yes	
Ribbon End/Ribbon Low	Yes	
Paper sensor	Option	
Controls		
Control Lamps	3	
Display	2 × 16 character LCD	Background light
Keyboard	7 keys membrane-switch type	
Feed/Pause button	1	
Beeper	Yes	
Data Interfaces		
Serial	1 × RS-232 + 1 × USB	
Connection for Optional Interface Boards	1 + 2	1 for EasyLAN 2 for other boards
Finisher Interface	1	For cutter etc.
Memory Card Adapter	1	CompactFlash cards
Accessories and Options		
Special Printheads	8 dots/mm (202.3 dpi): 1 type	Thick media
Integral Self-strip Unit with Liner Takeup	Option	For peel-off operation
Rotating Media Supply Hub	Option	Replaces supply post
3-inch Adapter for Media	Option	Supply hub only
Media Roll Retainer	Option	Supply hub only
Internal Fan-fold Guide	Option	
Side Door with Keylock	Option	

Appendix A—Technical Data

Cutter and Tray	Option	
Label Taken Sensor	Option	
RS-232 Cable	Option	
Parallel Interface Cable	Option	
Parallel Interface Board	Option	IEEE 1284
EasyLAN Ethernet Inter- face	Option	
EasyLAN Wireless Inter- face	Option	
External Alphanumeric Keyboard	Option	
CompactFlash Cards	Option	8MB-1GB

^{1/}. The max. print length is also restricted by the amount of free SDRAM memory.

^{2/}. Latin, Greek, and Cyrillic fonts according to Unicode standard are included.

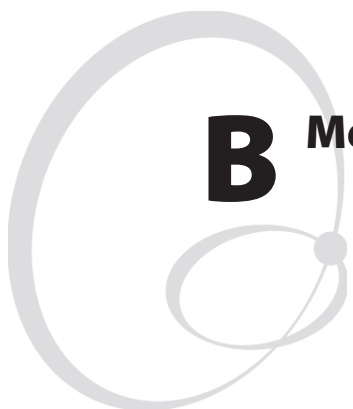

B Media Specifications

This appendix specifies the physical measures for various types of media.

Media Roll Size

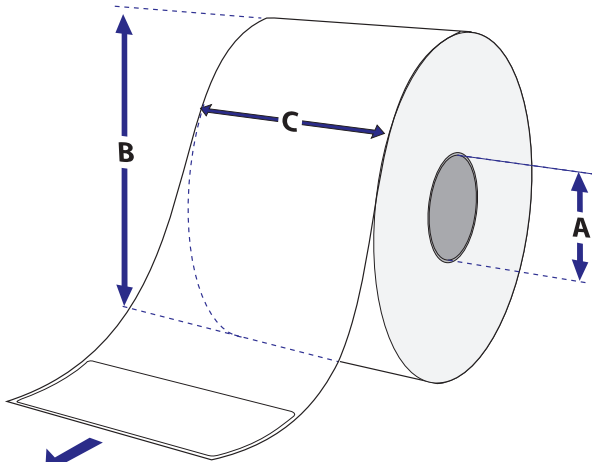

Diameter (A), standard:	38-40 mm	(1.5 inches)
Diameter (A), with adapter:	76.2 mm	(3 inches)
Width: Must not protrude outside the media.		



The media must be wound up on the core in such a way that the printer can pull the end free.

Roll

Max. diameter (B):	213 mm	(8.38 inches)
Max. width (C):	114.3 mm	(4.50 inches)
Min. width, standard (C):	25 mm	(1.00 inches)
Min. width, fan-fold guides (C):	40 mm	(1.57 inches)

The maximum recommended media thickness is 175 μ m (7 mils) with the standard printhead or 220 μ m (8.7 mils) with a special printhead. Thicker media may be used, but print quality will be reduced. The stiffness is also important and must be balanced against thickness to maintain print quality.

Media rolls to be loaded inside the printer should be wound with the printable side facing outwards.

The media supply must not be exposed to dust, sand, grit, etc. Any hard particles, however small, can damage the printhead.

Media

Non-Adhesive Strip

⇐ a ⇒ Media Width

Maximum: 114.3 mm (4.50 inches)

Minimum: 25.0 mm (1.00 inches)

Media Type Setup

- Continuous

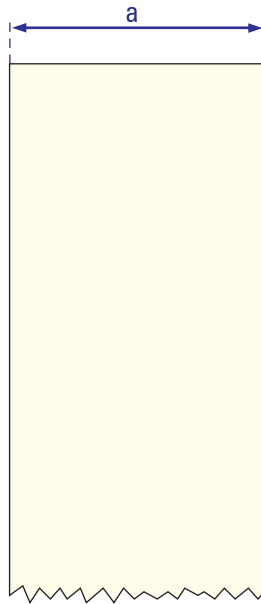

Self-Adhesive Strip

⇐ **a** ⇒ **Media Width (including liner)**

Maximum: 114.3 mm (4.50 inches)

Minimum: 25.0 mm (1.00 inches)

⇐ **b** ⇒ **Liner**

The liner must not extend more than a total of 1.6 mm (0.06 inches) outside the face material and should protrude equally on both sides.

⇐ **c** ⇒ **Media Width (excluding liner)**

Maximum: 112.7 mm (4.43 inches)

Minimum: 23.8 mm (0.94 inches)

Media Type Setup

- Continuous

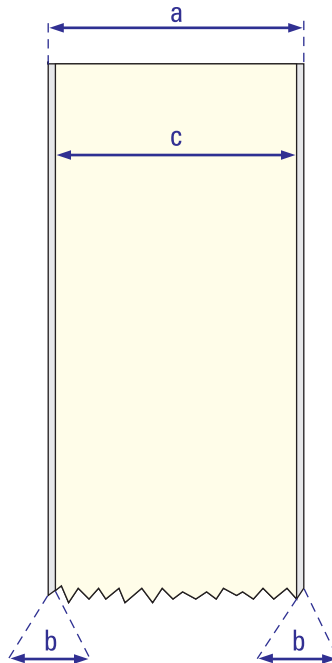

Self-Adhesive Labels

← a ⇒ Media Width (including liner)

Maximum:	114.3 mm (4.50 inches)
Minimum:	25.0 mm (1.00 inches)

← b ⇒ Liner

The backing paper must not extend more than a total of 1.6 mm (0.06 inches) outside the labels and should protrude equally on both side. Recommended minimum transparency: 40% (DIN 53147).

← c ⇒ Label Width (excluding liner)

Maximum:	112.7 mm (2.30 inches)
Minimum:	23.8 mm (0.94 inches)

← d ⇒ Label Length

Maximum:	depends on SDRAM size
Minimum:	8.0 mm (0.32 inches)

Under ideal circumstances, a minimum label length of 4 mm (0.16 inches) could be used. It requires the sum of the label length (d) and the label gap (e) to be larger than 7 mm (0.28 inches), that batch printing is used, and that no pull back of the media is performed. Intermec does not guarantee that such short labels will work, but it is up to the user to test this in his unique application.

← e ⇒ Label Gap

Maximum:	21.3 mm (0.83 inches)
Recommended:	3.0 mm (0.12 inches)
Minimum:	1.2 mm (0.05 inches)

The Label Stop Sensor must be able to detect the extreme front edges of the labels.

Media Type Setup

- Gap

Appendix B—Media Specifications

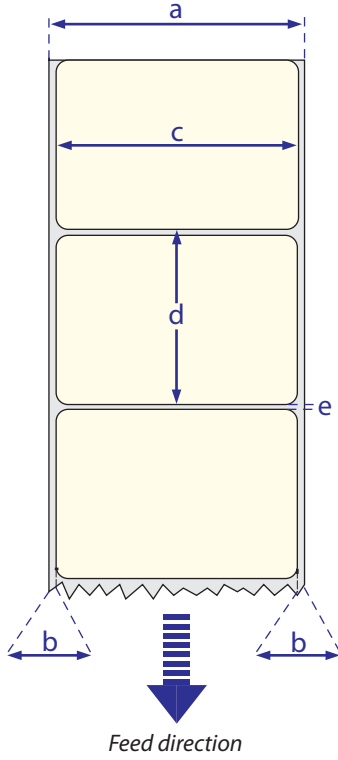

Tickets with Gaps

⇐ a ⇒ Media Width

Maximum:	114.3 mm (4.50 inches)
Minimum:	25.0 mm (1.00 inches)

⇐ b ⇒ Copy Length

Max. length between slots:	depends on SDRAM size
Min. length between slots:	8.0 mm (0.32 inches)

Under ideal circumstances, a minimum ticket length of 4 mm (0.16 inches) could be used. It requires the sum of the copy length (b) and the detection slit height (e) to be larger than 7 mm (0.28 inches), that batch printing is used, and that no pull back of the media is performed. Intermec does not guarantee that such short tickets will work, but it is up to the user to test this in his unique application.

⇐ c ⇒ LSS Detection Position

Variable, see Chapter 11.

⇐ d ⇒ Detection Slit Length

The length of the detection slit (excluding corner radii) must be minimum 2.5 mm (0.10 inches) on either side of the LSS detection position (e).

⇐ e ⇒ Detection Slit Height

Maximum:	21.3 mm (0.83 inches)
Recommended:	1.6 mm (0.06 inches)
Minimum:	1.2 mm (0.05 inches)

Media Type Setup

- Gap



Note: Do not allow any perforation to break the edge of the media as this may cause the media to split and jam the printer.

Appendix B—Media Specifications

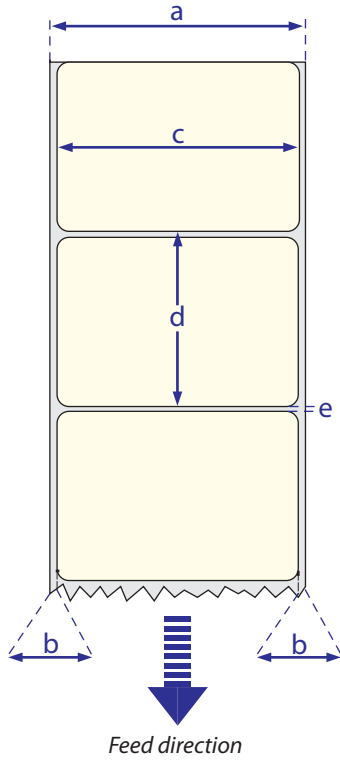

Tickets with Black Mark

⇐ a ⇒ Media Width

Maximum:	114.3 mm (4.50 inches)
Minimum:	25.0 mm (1.00 inches)

⇐ b ⇒ Copy Length

Minimum:	20.0 mm (0.8 inches)
Maximum:	depends on SDRAM size

⇐ c ⇒ LSS Detection Position

Variable, see Chapter 11.

⇐ d ⇒ Black Mark Width

The detectable width of the black mark should be at least 5.0 mm (0.2 inches) on either side of the LSS detection point.

⇐ e ⇒ Black Mark Length

Maximum:	21.3 mm (0.83 inches)
Common:	12.5 mm (0.5 inches)
Minimum:	5.0 mm (0.2 inches)

⇐ f ⇒ Black Mark Y-Position

It is recommended that you place the black mark as close to the front edge of the ticket as possible and use a negative Stop Adjust value to control the media feed, so the tickets can be properly torn off.

Media Type Setup

- Mark



Note: Preprint that may interfere with the detection of the black mark should be avoided.



Note: The black mark should be non-reflective carbon black on a whitish background. Do not allow any perforations to break the edge of the media as this may cause the media to split and jam the printer.

Appendix B—Media Specifications

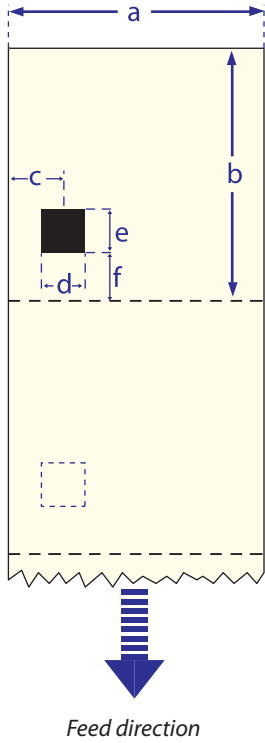

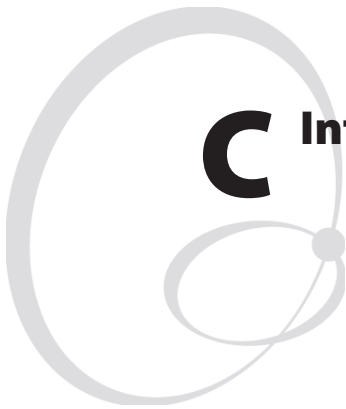

C Interfaces

This appendix describes the interface connectors found on the printer's rear plate. It covers the following topics:

- RS-232 interface
- USB interface
- Optional interface boards

RS-232 Interface

Protocol

Default setup:

Baud rate: 9600
Char. length 8 bits
Parity: None
Stop bits: 1
RTS/CTS Disabled
ENQ/ACK: Disabled
XON/XOFF: Disabled (both ways)
New Line: CR/LF

To change the RS-232 interface settings, see Chapter 6, “Setting Up the Printer.”

Signals on printer’s serial port:

DB-9	Signal	Meaning
1		External +5V DC*
2	TXD	Transmit data
3	RXD	Receive data
4	DSR	Data set ready
5	GND	Ground
6	DTR	Data terminal ready
7	CTS	Clear to send
8	RTS	Request to send
9	–	Not used

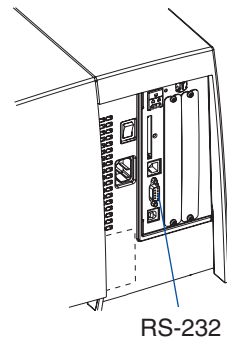

*1. The external +5V is limited to 500 mA and is automatically switched off at overload.

Interface Cable

Computer end: Depends on computer model
Printer end: DB-9pin plug

USB Interface

This printer supports USB v1.1 (also called USB 2.0 full speed). To use the USB interface for printing from a PC, you need a special Intermec USB printer driver installed in your PC.

The printer is a so called “self-powered device.” We recommend that you only connect one printer to each USB port on the host, either directly or via a hub. Other devices, like a keyboard and a mouse, can be connected to the same hub. If you need to connect more than one Intermec USB printer to a host, you should use different USB ports.

Using a USB Class A/B cable, connect the Class A plug to your PC or hub and the Class B plug to your printer.

The USB interface is essentially a one-way communication interface and is thus not recommended for programming. There is no communication setup for the USB port.

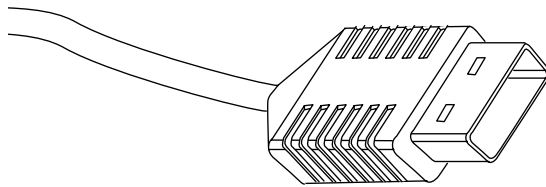

*USB Class A connector.
Connect to PC or hub.*

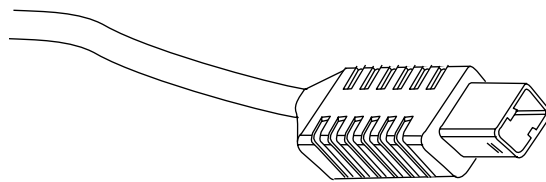

*USB Class B connector.
Connect to USB receptacle on the printer's rear plate.*

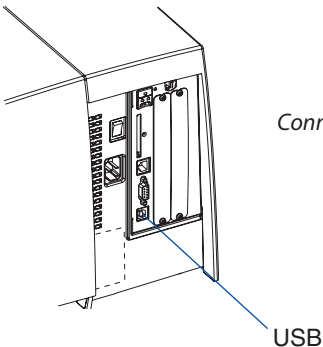

Optional Interfaces

The printer can optionally be fitted with an IEEE 1284 Parallel Interface Board at the right-hand side of the printer's rear plate.

Regardless of if any Parallel Interface Board is installed, the printer can also be fitted with one of the following EasyLAN interface boards for connection to a Local Area Network (LAN):

- EasyLAN Ethernet Interface
- EasyLAN Wireless Interface

IEEE 1284 Parallel Interface Board

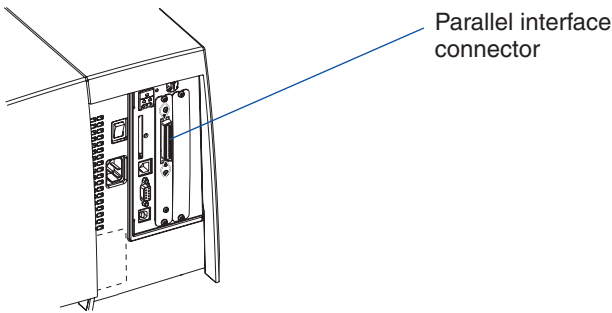

EasyLAN Ethernet Interface

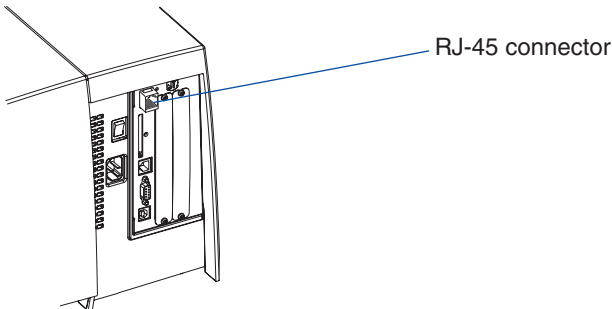

EasyLAN Wireless Interface

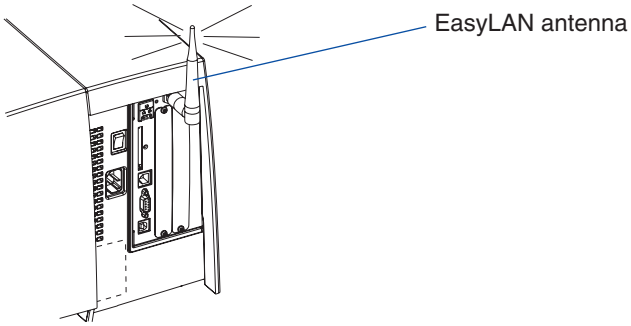



D Intermec Supplies

This appendix describes how to set up the printer for various types of direct thermal media or combinations of thermal transfer ribbons and receiving face materials marketed by Intermec.

Setting the Media Sensitivity Number

Media sensitivity is important because you use it to optimize print quality and print speed. The three-digit sensitivity specifies the amount of heat required by the printhead to image a label. The amount of heat that each roll of media or ribbon requires is unique due to different chemistries and manufacturing processes.

Intermec has developed heating schedules (the amount of heat required to image a label) to produce the highest possible print quality for Intermec media and ribbon combinations on Intermec printers. Look for the three-digit media sensitivity number on:

- The side of the media roll. Use the last three digits (140 in the example below) of the 15-digit number stamped on the roll for the media sensitivity number.
- A small label attached to the roll of media.
- A small label attached to the plastic bag of your ribbon roll.

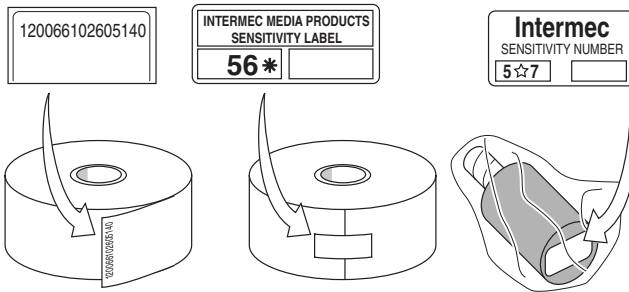

Use this three-digit number to optimize print quality and print speed on your printer. You can achieve the best print quality on the printer by using Intermec ribbon and media products.

The default printer setting for direct thermal media is 420. For thermal transfer media, the default setting is 567. Use the information on the packaging that you saved when loading media and ribbon to determine the correct sensitivity number.

Use the Setup Mode (see “Sensitivity” in Chapter 6-7), PrintSet, your third-party software, or the Intermec printer language (IPL) command set to change the media sensitivity number. For help on how to set the media sensitivity number using the printer command set, see the DOS example on the following page.

The sensitivity number on each roll of thermal transfer media or ribbon has an asterisk (*) in place of one of the digits. To optimize the sensitivity number for thermal transfer media, you combine the digits as in this example.

Media or Ribbon	Sensitivity Rating	Description
Thermal transfer media	56*	The asterisk for the third digit is reserved to identify the ribbon's sensitivity number.
Thermal transfer ribbon	5*7	The asterisk for the second digit is reserved to identify the media's sensitivity number.
	567	Optimum sensitivity rating

To set the sensitivity rating for direct thermal media, use the three-digit sensitivity rating located on the roll of media or listed later in this chapter.

Use DOS to set the media sensitivity number on a PC like this:

1. At the DOS prompt, type the following command and press Enter:

```
MODE COM1 96,E,7,1,N
```

2. Type the following command lines and press Enter:

```
COPY CON COM1
```

```
<STX><SI>g1,567<ETX>^Z
```

where:

<SI>g1,567 sets the media sensitivity number to 567.

Direct Thermal Media Sensitivity Settings

Sensitivity Level	Setting	Direct Thermal Media
700 Series High Sensitivity	720	Duratherm Lightning Plus 2
400 Series Medium Sensitivity	480	Duratherm Lightning IR Tag
	470	Duratherm Lightning-2
	460	European IR
	450	Duratherm Lightning IR
	440	European Thermal
	420	Duratherm Lightning-1
100 Series Low Sensitivity	180	Duratherm Lightning II-1
	170	European Tag
	160	Duratherm II Tag
	140	European Top
	130	Duratherm II-2
	120	European Thermal Eco Tag

Thermal Transfer Media and Ribbon Sensitivity Settings

Sensitivity Level	Setting	Media/Ribbon Stock
800 Series High Sensitivity (Paper)	864	European Uncoated/Standard
	854	Duratran TTR Paper Labels/Standard
600 Series Medium Sensitivity (Plastic)	687	Duratran II Matte Polyester or Valeron/Premium
	677	Duratran II Syntran/Premium
	673	Duratran II Syntran/Standard
	647	Tyvek/Premium
	633	European Matte & Gloss PE/Premium
	627	Kimdura/Premium
	623	Kimdura/Standard
500 Series Medium Sensitivity (Paper)	567	Duratran II/Premium
	565	European Premium Paper/Premium
	563	Duratran II/Standard
	533	European Tag/Premium
	527	Duratran II Tag 5 & 7mil/Premium
300 Series Low Sensitivity (Plastic)	513	European Coated TT/Premium
	369	Duratran II Gloss Polyester/Super Premium (Europe)
200 Series Low Sensitivity (Kapton)	366	Duratran II Gloss Polyester/Super Premium (North America)
	238	Gloss White Kapton/Gloss Super Premium
	236	Gloss White Kapton/Super Premium
	226	Matte White Kapton/Super Premium
	222	Matte White Kapton/Matte Super Premium



Intermec Technologies Corporation

Corporate Headquarters
6001 36th Avenue West
Everett, WA 98203
U.S.A.

tel +425.348.2600

fax +425.355.9551

www.intermec.com

EasyCoder PM4i Bar Code Label Printer, User's Guide (IPL Version)



1-960584-03