

Triton Owner's Manual

CAPACITIES: **LIGHT** | **MEDIUM** | **HEAVY** 4,400-25,000 LBS.

HarborHoist™

BY HYDROHOIST® BOAT LIFTS



800.825.3379 | Boatlift.com

© 2020 HydroHoist® – US Patent No. 6,422,167 B1
06-20

 **HydroHoist®**
BOAT LIFTS



Damage to your lift or vessel can result from improper initial setup of the system. Consult a HydroHoist Certified Installer for initial setup and support.

- Installation and service should be performed by a qualified service professional.
- To avoid the risk of electric shock make sure the control is disconnected from any power supply during installation.
- The GFCI supplied with your control is designed for outdoor applications but is NOT to be submerged or directly sprayed with water. Keep the GFCI from being directly sprayed by the exhaust port of the control.
- Verify that your power receptacle is clean and is supplying the proper power for your model of control. *See Appendix A for requirements.*
- Do not allow children to operate the lift. Keep children away while lift is in operation.
- Do not allow yourself to be distracted or walk away from the lift during operation.
- Do not overload the lift. Make sure your boat bilge pump is set to automatic. Significant water accumulation in the bilge may overload the lift.
- Make sure any ballast tanks are empty before lifting the boat.
- Lift should not be operated while the vessel is occupied.
- No person(s) should be under the boat while it is in raised position.
- Weight must be distributed equally side to side and bow to stern before lifting, otherwise, the boat will not center properly and appear to be misaligned on the lift.

Symbols:



Informational purposes



WARNING

Control Configurations and Functionality

The HarborHoist is a versatile boat lift system. The control and functionality of this type of lift will vary with capacity. *See the table below for which type of control figuration fits your lift.*

Lift Capacity	Control Configuration
4400, 6600, 8800	4 Valve
8800 Short, 12000, 15000, 18000, 20000	5 Valve
25000	6 valve



IMPORTANT: WHEN PLUGGING IN THE CONTROL THERE WILL BE A 5 SECOND DELAY BEFORE THE CONTROL IS READY FOR USE. THIS ALLOWS THE SYSTEM TIME TO BOOT UP.

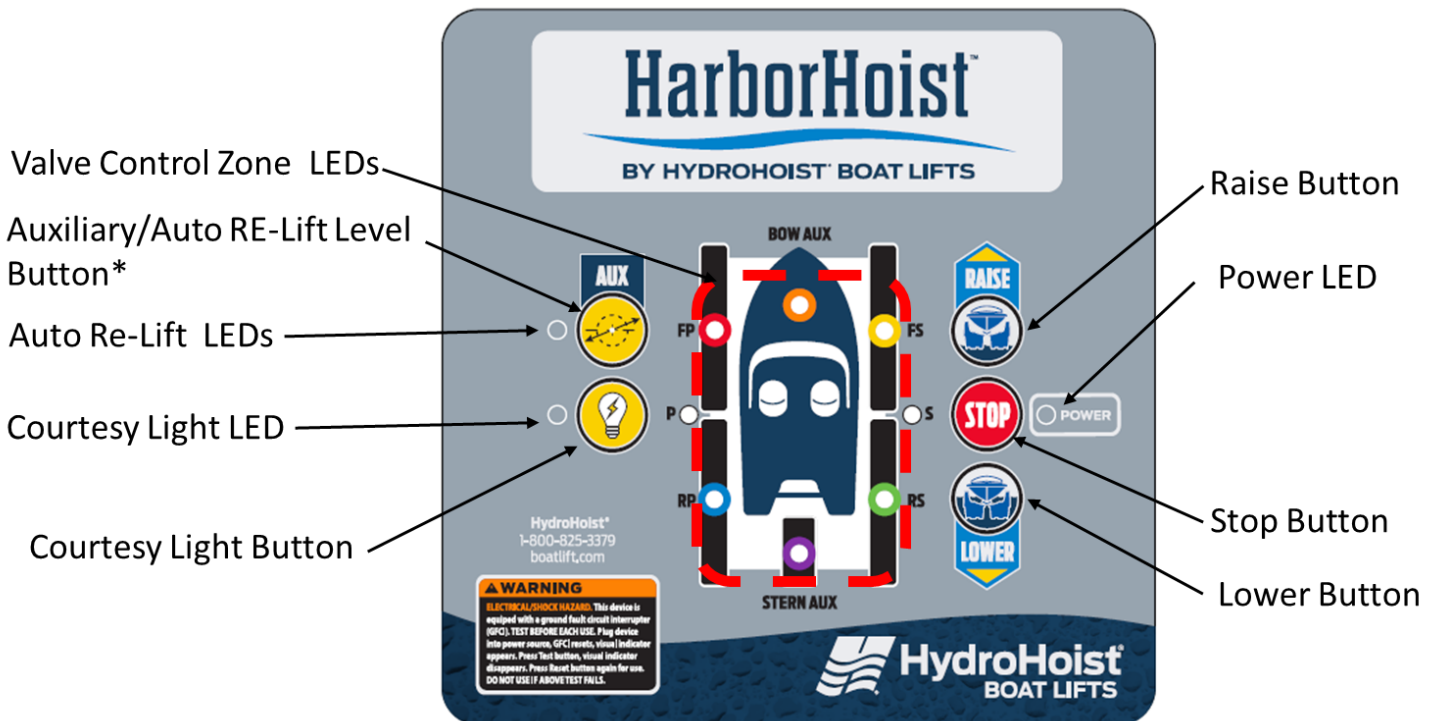

* The 5 and 6 Valve have the additional functionality of filling the auxiliary tanks under the lift. See page 4 for operation of this feature.

Basic Functionality and Nomenclature of Lift System

The HarborHoist lift system comprises itself of main tanks that balance and lift around the parameter of the vessel. Larger lifts will incorporate auxiliary tanks located underneath the vessel to support the lifting capacity.

The control system is equipped with a level sensor that is mounted to the frame of the HarborHoist lift. As the unit is either raised or lowered, the level sensor opens and closes the valve system in order to maintain a level-lift of the vessel.



During **RAISING MODE**, lifts equipped with auxiliary tanks should allow the main tanks to completely exhaust the water from them, as indicated by bubbles escaping from under them. Now, press the **AUX** button to allow air to flow only to the auxiliary tanks until they bubble. At this point, the maximum lifting capacity has been achieved.

To achieve the maximum performance of the lift, it is critical that the vessel be balanced properly on lift. The installer can support you on placing the vessel on the lift and should **always be located on the lift at the same location** unless the vessel has been refitted with additional weight.

Nomenclature of the valve zones of the system

FP = Front Port Main Tanks Zone

FS = Front Starboard Main Tanks Zone

RP = Rear Port Main Tanks Zone

RS = Rear Starboard Main Tanks Zone

Stern Aux = Stern Auxiliary Tanks (only on 5 and 6 Valve systems)

Bow Aux = Front Auxiliary Tanks (only on 6 Valve systems)

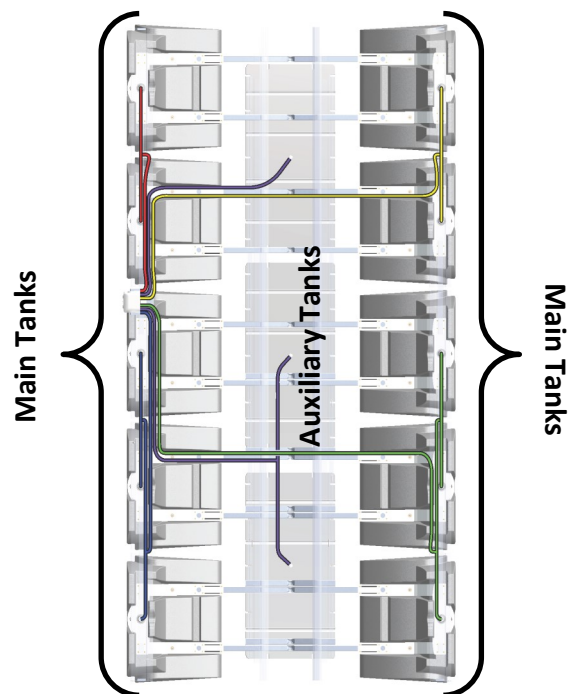
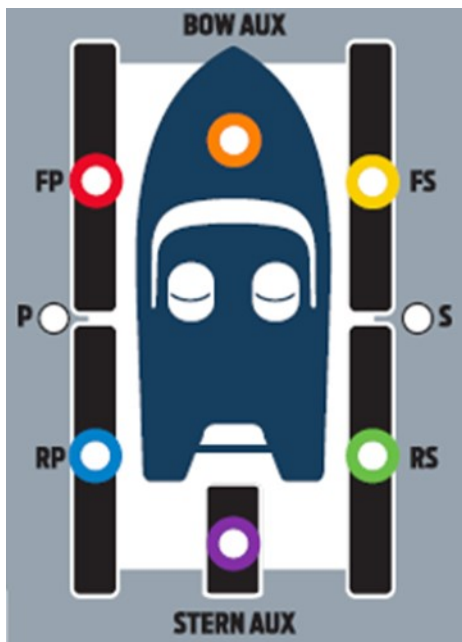

Basic Operations of the Control



Raise Mode turns blower on and activates the valve system to lift the vessel

- Power LED is solid **GREEN** during this mode
- Raise Mode will automatically shut off after 15 minutes if **STOP** is not pressed



Lower Mode activates the valve system to lower the vessel

- Power LED is solid **GREEN** during this mode
- Lower mode will automatically shut off after 20 minutes if **STOP** is not pressed



Stop Mode shuts all valves and verifies blower is off

- Power LED is solid **RED** in this mode



AUX Mode (Only on 5 and 6 valve controls)

- Press and release AUX button to activate
- This will allow air to be directed **only** to the auxiliary tanks to remove any residual water, thus increasing lifting capacity. When air bubbles come from underneath the aux tanks the full capacity has been achieved



Hold 10 sec

Factory Resets

- Press and hold the **STOP** button down for 10 seconds
- Power LED will flash **GREEN** 3 times indicating the reset has completed
- Restores all settings to factory and erases Boarding Height, Raise Timers, and sets the level sensor back to factory level reference



Advanced Functionality of the Control

Timed Light Mode

- Press and release **LIGHT** button, the light will turn on for 10 minutes and then shuts off
- Light LED will flash **BLUE** while activated



Continuous Light Mode

- Press and hold the **LIGHT** button for 3 seconds and the light will stay on continuously
- Light LED is solid **BLUE** while activated



To Turn Light Off in either mode, press and release the LIGHT Button

Auto Re-Lift Mode If for some unexpected reason the lift becomes out-of-level while in the raised position by more than two degrees, the control will automatically turn on and re-lift and level the lift and shut off, re-arm and continue in monitoring mode.



Hold 3 sec

- To activate this feature, press and hold the **AUX/LEVEL** button for 3 seconds
- The power LED will flash **GREEN** 3 times indicating it is active
- While active, the Auto Re-Lift LED will flash **BLUE** slowly indicating it is armed
- If any section(s) of the hoist is Auto Re-Lifted, then that section will be reported by the valve zone(s) LED flashing **BLUE**
- To clear the mode, press the **STOP** button



NOTE: After each use of the lift, this feature must be manually armed, it is NOT an automatic feature. If the boat is loaded out-of-balance by more than 2 degrees, then the mode will NOT allow it to be engaged.

Set Boarding Height Timer allows you to lower the vessel to a set height off the water to load or unload your vessel while the lift holds the vessel from floating away



Hold 3 sec

Important: This feature MUST be set or used from the fully raised position with ONLY the boat on the hoist.

- Instructions to set Boarding Height Timer: Press **LOWER** and wait until the vessel reaches the desired boarding height. Once the desired boarding height is reached, press and hold the **LOWER** button for 3 seconds.
- Power LED will flash **GREEN** 3 times indicating the boarding height timer has been set.
- To activate Boarding Height Mode: Press and hold **LOWER** for 3 seconds.



Remember, this feature MUST start from a fully raised position. The Power LED will turn solid **BLUE** indicating you are in Boarding Height Mode. It will run the amount of time set from the above step and then return to **STOP** mode. You can also press **STOP** at anytime to cancel boarding height.

Advanced Functionality of the Control



Hold 3 sec

Clear Boarding Height Timer

Important: To set a new Boarding Height you must first clear the old timer.

- Press and Hold the **LOWER** and **STOP** buttons together for 3 seconds
- Power LED will flash **GREEN** 3 times indicating it has been cleared



Hold 3 sec

Set Raise Timer allows you to set a less amount of time for **RAISE MODE** other than the default 15 minutes. *Ideal feature for solar or battery option to save power*

Important: This feature MUST be set when the lift is completely lowered

- To set: Press **RAISE** then wait until the vessel is completely up and all tanks are bubbling and allow it to run an additional 30 seconds
- Then Press and Hold the **RAISE** button for 3 seconds
- Power LED will flash 3 times **GREEN** indicating the Raise Timer is set



Hold 3 sec

Clear Raise Height Timer

Important: To set a new Raise Height Timer you must first clear the old one

- Press and Hold the **RAISE** and **STOP** buttons together for 3 seconds
- Power LED will flash **GREEN** 3 times indicating it has been cleared



Utility and Configuration Functions



Hold 3 sec

Calibration of Level Sensor allows you the ability to set the “level” reference of the lift
Warning: Calibration MUST be performed with the lift fully lowered. Then, lift vessel fully and verify vessel is balanced correctly. Repeat the calibration again at a fully raised position

- Press and hold **RAISE** and **LOWER** together for 3 seconds.
- **P** and **S** LEDs will flash **BLUE** together 5 times
- **If the lift is out of level by 6 degrees or more, it will fail to calibrate.**
 - ◆ This will be indicated by the zone LEDs **FP & RP** flashing alternately **BLUE** with **FS & RS** 5 times
 - ◆ To resolve, reposition the vessel on the lift or verify the level sensor is secured to the frame level and properly

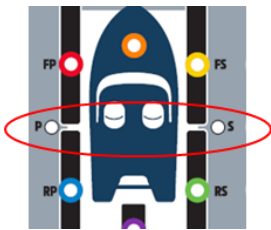

Emergency Shut-Off Mode is automatically activated when the lift becomes **more than 5 degrees out-of-level.** This extreme out-of-level condition could have been caused by the lift having an air leak, the vessel was loaded out-of-balance, or rainwater has accumulated in the vessel

- The **P & S** LEDs will flash **BLUE** rapidly alternating. To clear the flashing, press the **STOP** button
- See **Express Down Mode** for how to get the vessel off the lift



Hold 3 sec

Express Up Mode **overrides the level safety features** and allows the lift to be raised. This is used when Emergency Shut-Off Mode has been triggered and you need to raise the lift back to level.

WARNING: DO NOT activate this mode with the vessel on the lift unless ONLY ONE SECTION of the main tanks has lost air. If at any time you feel uncertain about the operation, press the STOP button. DO NOT leave the lift un-attended during this operation.

- To activate the Express Up Mode press and hold **RAISE** and **AUX/LEVEL** buttons together for 3 seconds. The power LED will turn solid **GREEN**
- To stop the mode, press the **STOP** button



Hold 3 sec

Express Down Mode overrides the level safety features and allows the lift to lower. If for some reason the vessel and lift have gotten out-of-level by more than 4 degrees and the **Emergency Shut-Off Mode** has engaged, you may need to use this to lower the lift.

WARNING: DO NOT leave the lift unattended during this operation. If at anytime you feel uncertain about the operation press the **STOP** button and contact a certified dealer or HydroHoist directly.

- Press and hold **LOWER** and **AUX/LEVEL** buttons together for three seconds. The power LED will turn solid **GREEN**

Trouble Shooting Control



P&S flash together very quickly

- Loss of communication between the level sensor and the control box
- Review the level sensor cable for cuts or damage, then contact a certified dealer or HydroHoist directly for service or replacement of the level sensor

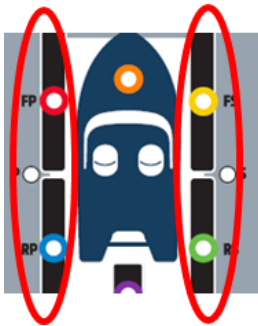

FP&RP flash alternating to FS&RS 5 times during calibration

- The lift is out of level by 6 degrees or more, indicating it can not calibrate the level sensor
- See **Calibration of Level Sensor** in the Utility Functions section



Auto Re-Lift Mode will NOT arm

- The lift is out-of-balance by 2 degrees or more and **Auto Re-Lift Mode** cannot be activated
- Lower vessel, reposition/re-balance and raise and retry to activate



Power LED will not turn solid red when power is applied

- Check power outlet source and verify you have power
- Check fuse is in good working condition and cap is on tight. You must push and turn to lock and unlock. If burnt, then replace with same type of fuse.
- **Warning: Unplug control to check fuse.**
 - ◆ Single Blower: Fuse: .25 X 1.25 SLOW BLOW- 20A 110 VAC
 - ◆ Dual Blower: Fuse: .25 X 1.25 - 30A 110 VAC
- Plug in and press **TEST** then **RESET** buttons on GFCI

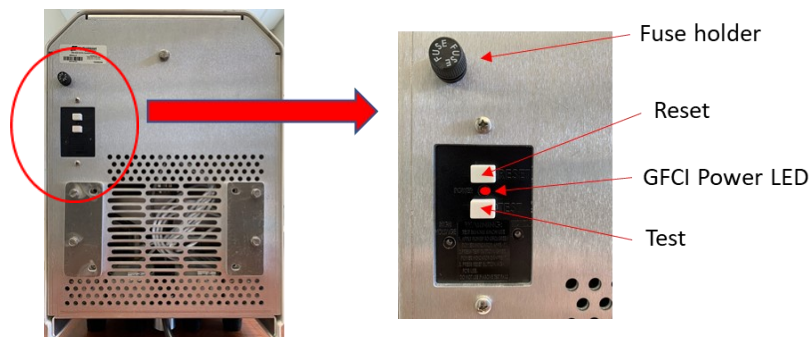

General Troubleshooting

Lift is not lifting the vessel level

- Re-position the vessel on the lift
- Verify weight is distributed evenly in the vessel
- Verify ballast tanks, bait or live wells do not have water remaining in them
- Verify the lift raises level when vessel is not on the lift
 - If lift is not level, verify sensor is connected to the frame properly and no damage has occurred to it or its cable
 - The level sensor may need to be calibrated back to zero level. See Calibration of Level Sensor on page 8. If this does not resolve the problem, a full Factory Reset may be needed (see page 5).

Tie-Off Mooring Information

(Mooring ropes not included)

Tie the lift off using a tie-off method similar to mooring a boat in a slip. The goal is to restrain the lift as much as possible but still leaving enough slack in the lines that the lift can still raise and lower properly.

Use a good mooring rope that has enough strength for the size of boat and lift you are installing. **Minimum Rope Diameter of 3/8" for boats up to 25', 1/2" for boats up to 35', and 5/8" for boats up to 45'.**

There are several variables involved in rope selection and tie-off locations, so be sure that you check the mooring regularly for any changes in rope condition, tie-off points, etc.

Be sure that all tie-off points are in good condition and are structurally sound enough to handle the load the mooring will apply.

Recommended: Double Braid Nylon Dock Lines

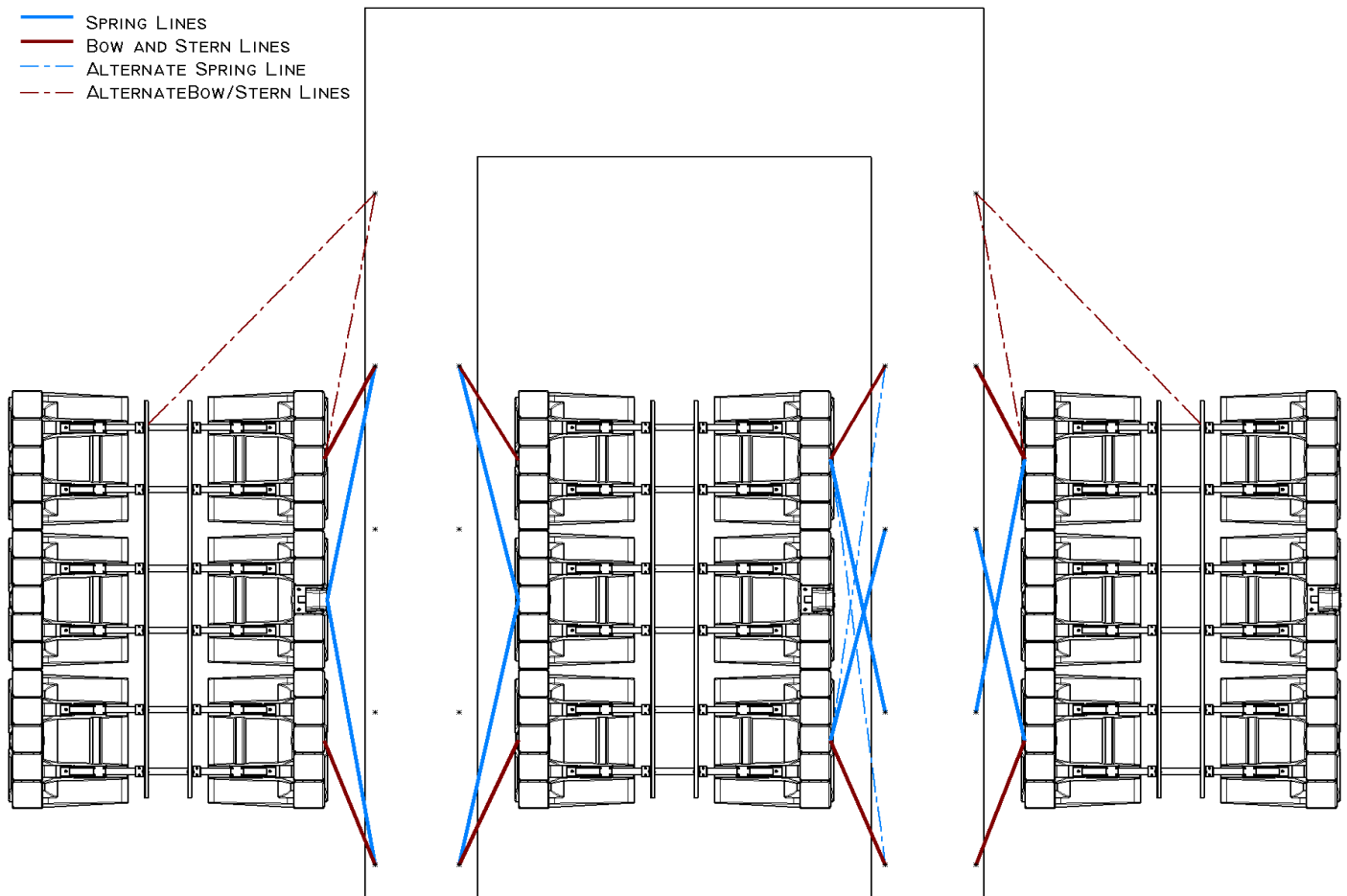

Vessel Loading

- Proper loading of your vessel onto the lift is extremely important!
- Failure to load properly could cause improper lifting of your vessel. Verify that the equipment weight is distributed evenly on the vessel to keep the **Center of Buoyancy (CB)** within manufacturer's limits.
- When loading, the **CB of the vessel should be within 1 foot forward or aft of the CB of the lift.** This should make for a level lift. Contact the vessel manufacturer for the CB of your vessel.
- To promote water drainage to the rear of the vessel, it is recommended that the vessel CB be aft of the lift CB.
- Some service vessels which are heavy, short in length, and utilize a lift with auxiliary tanks, may need to adjust auxiliary tank locations. Contact customer support or an authorized dealer if you feel you may have a vessel of this type.



Many of today's vessels have built-in ballast tanks to create additional wake or accommodate fishing boats for bait and fish. These tanks should be completely emptied before lifting the vessel. If not, damage could occur to the boat, lift, or dock.

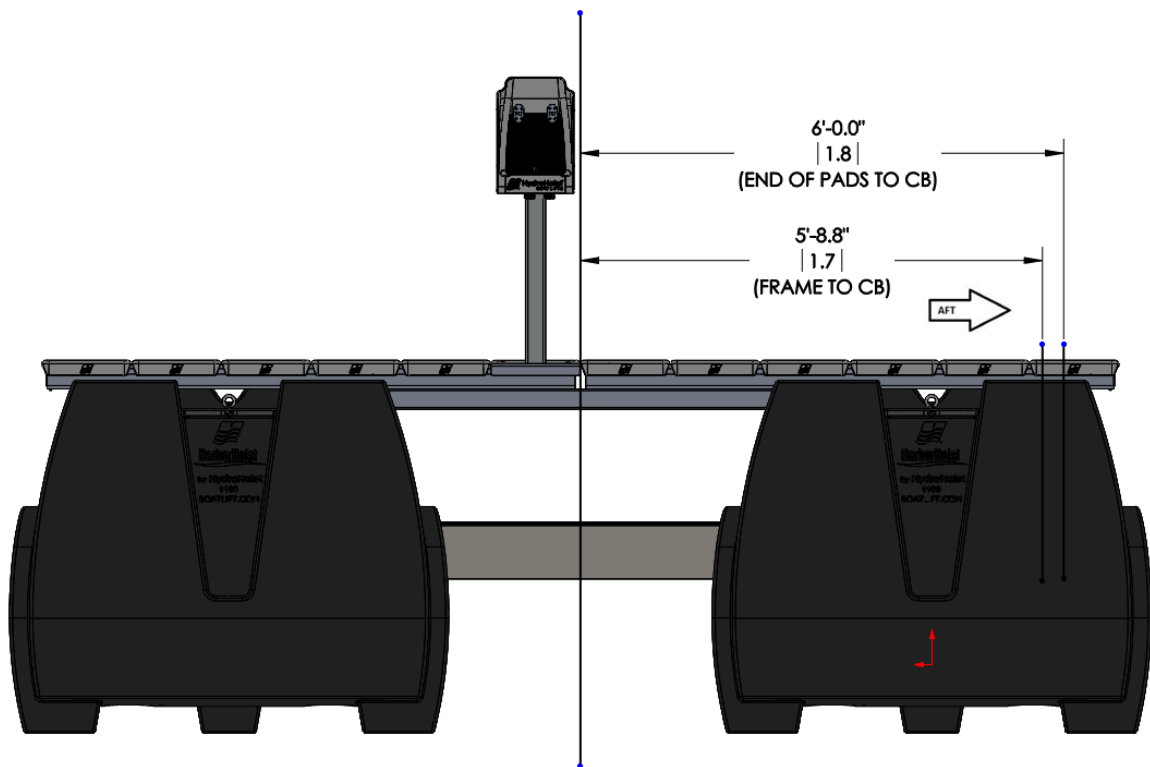

CB of 4400

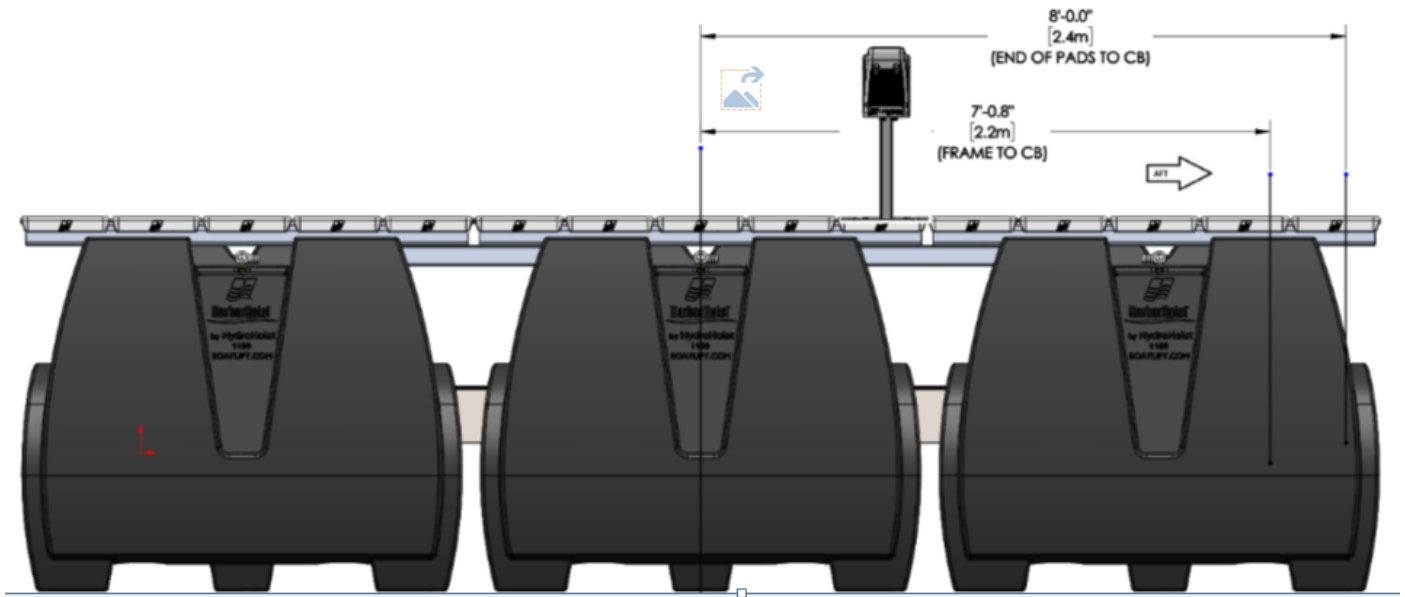

CB of 6600

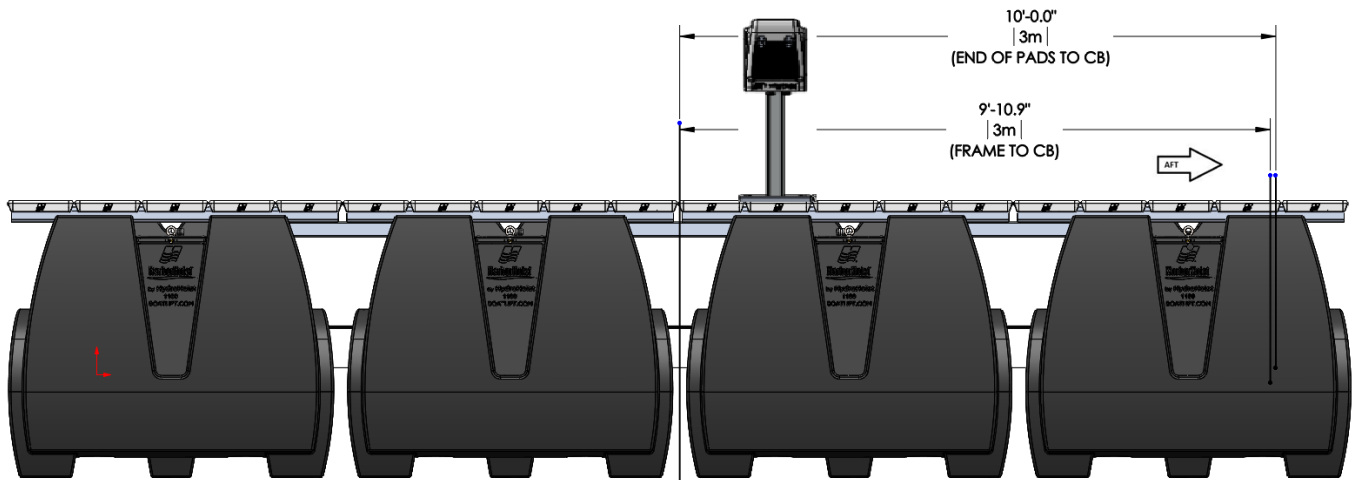

CB of 8800

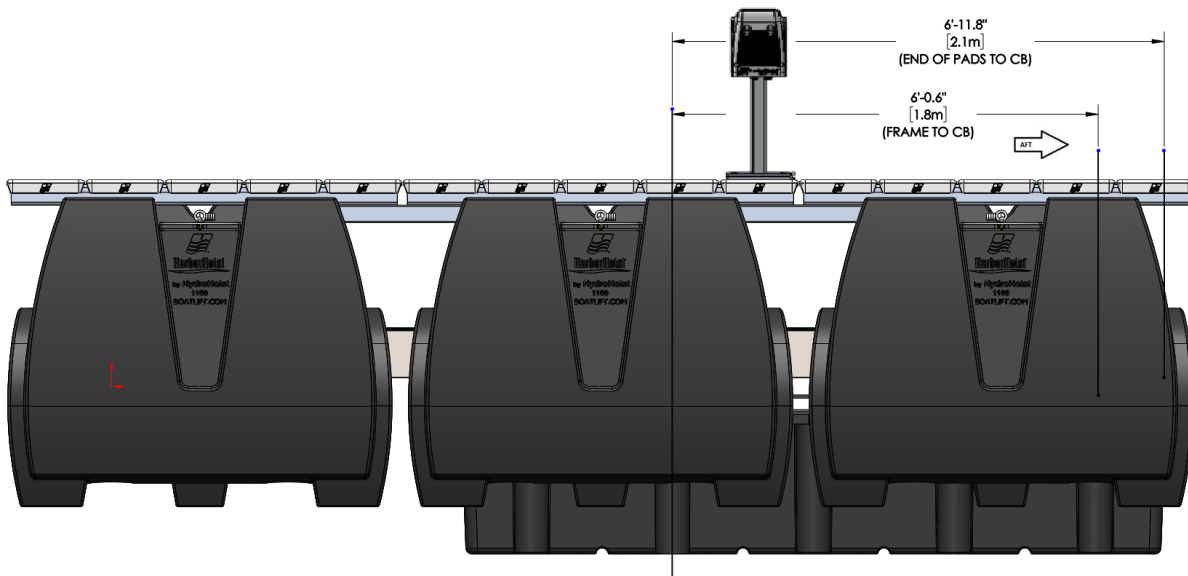

CB of 8800 Short

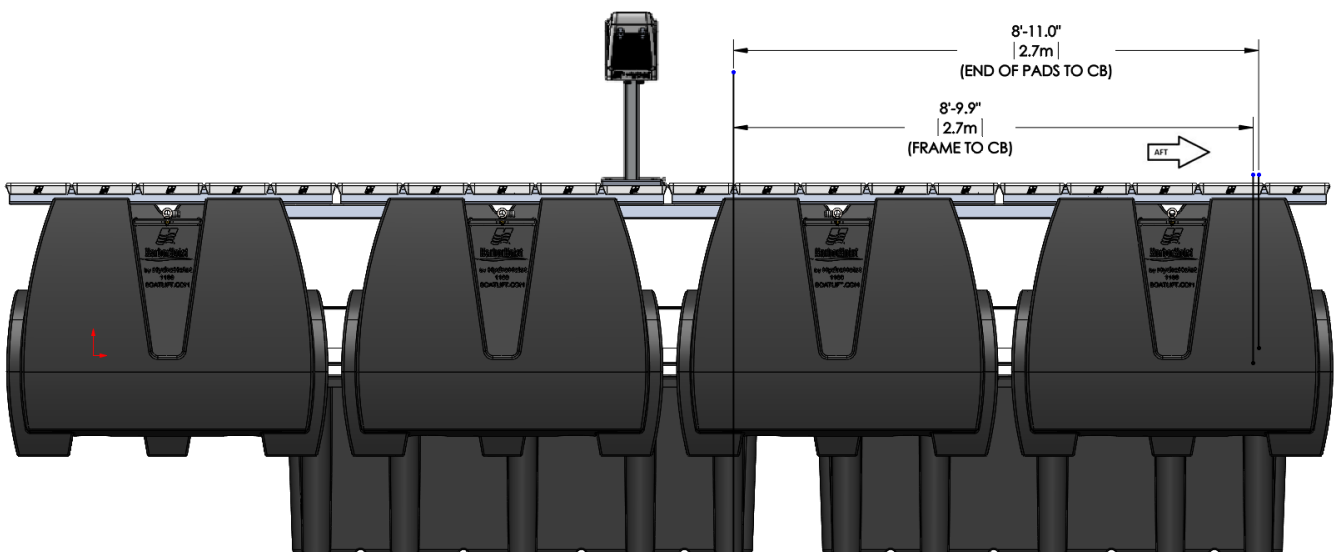
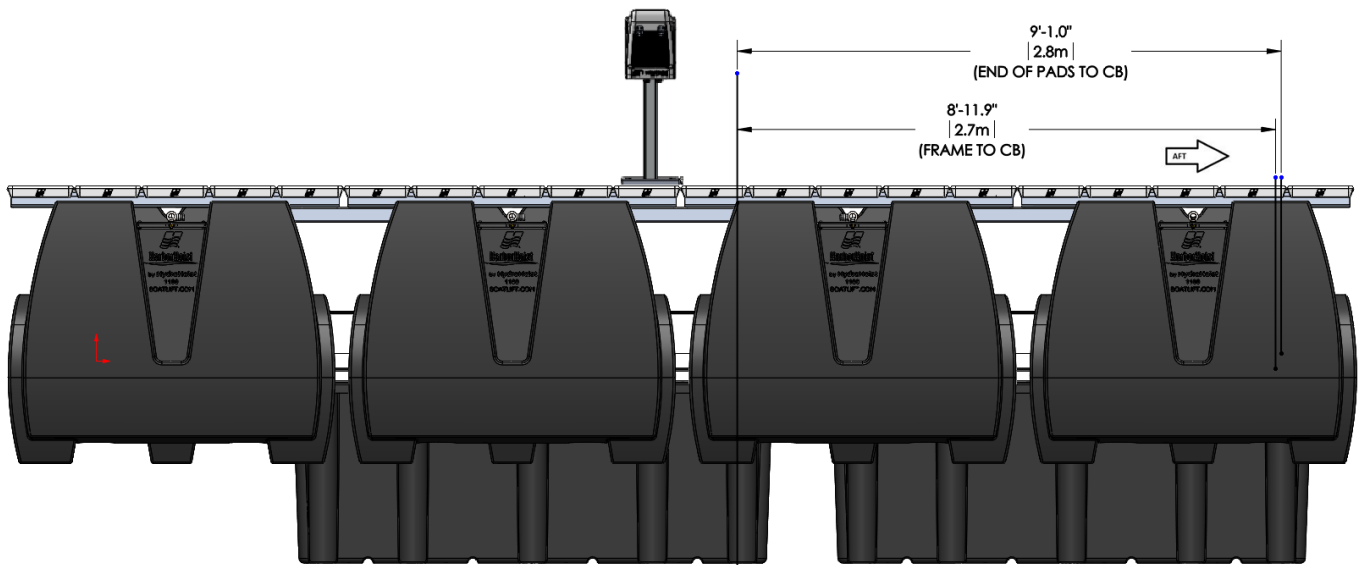
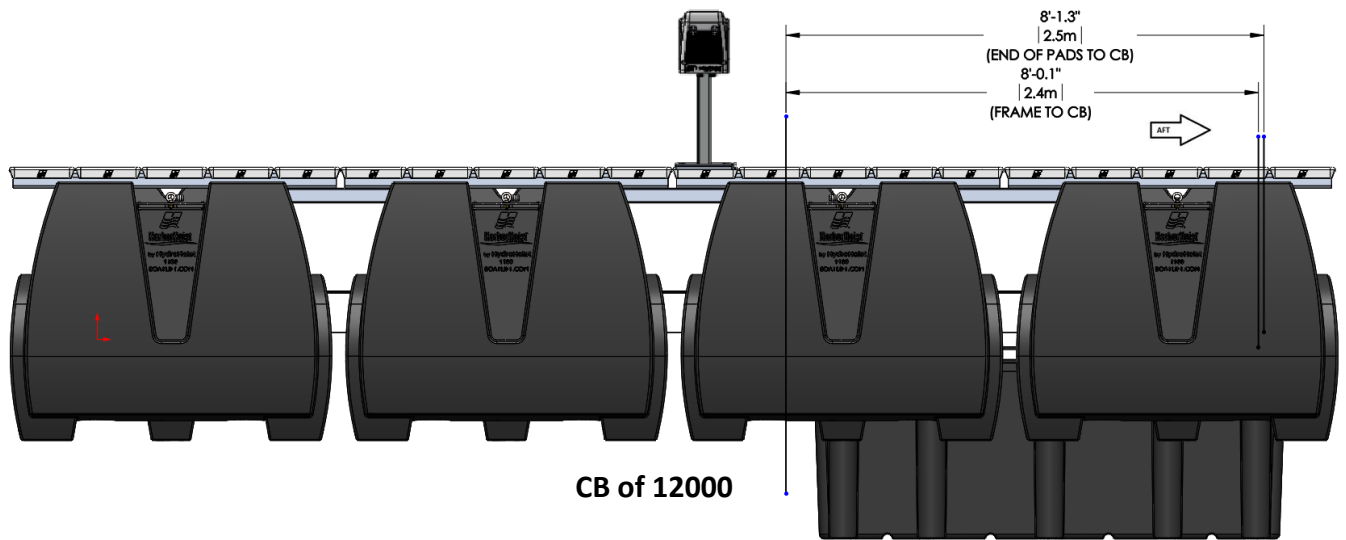

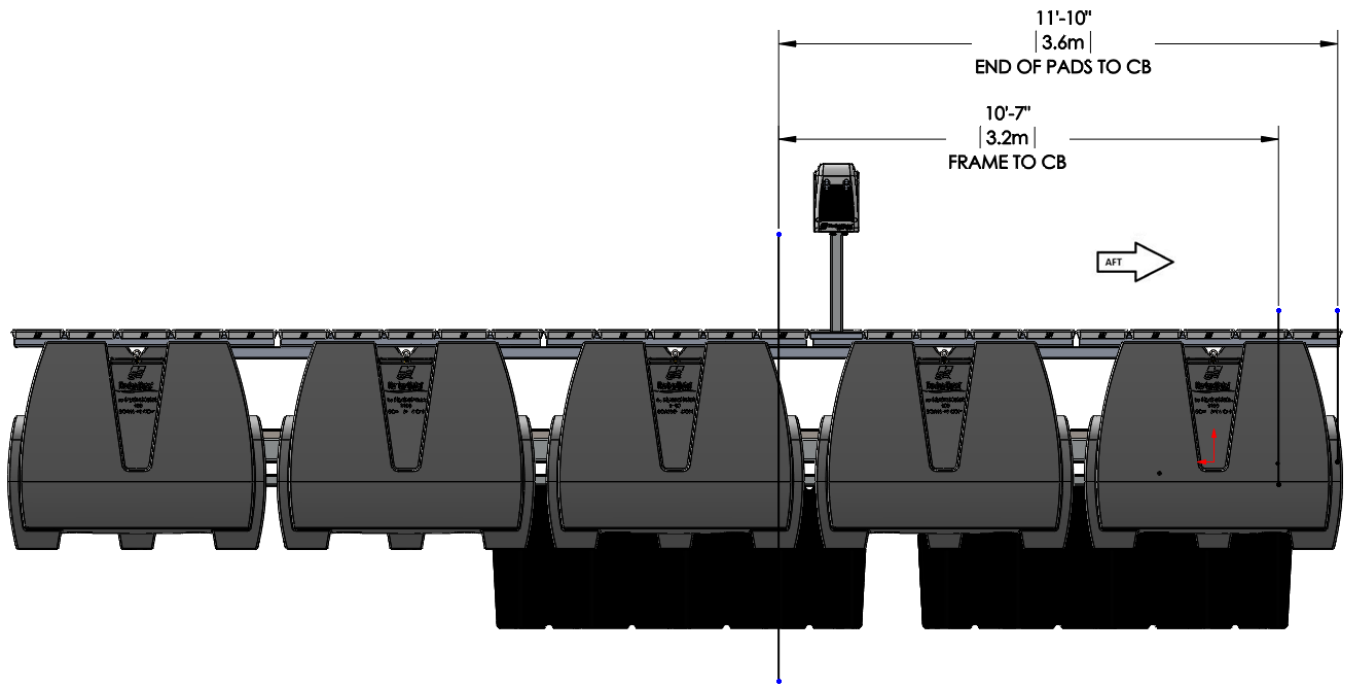

CB of 20000

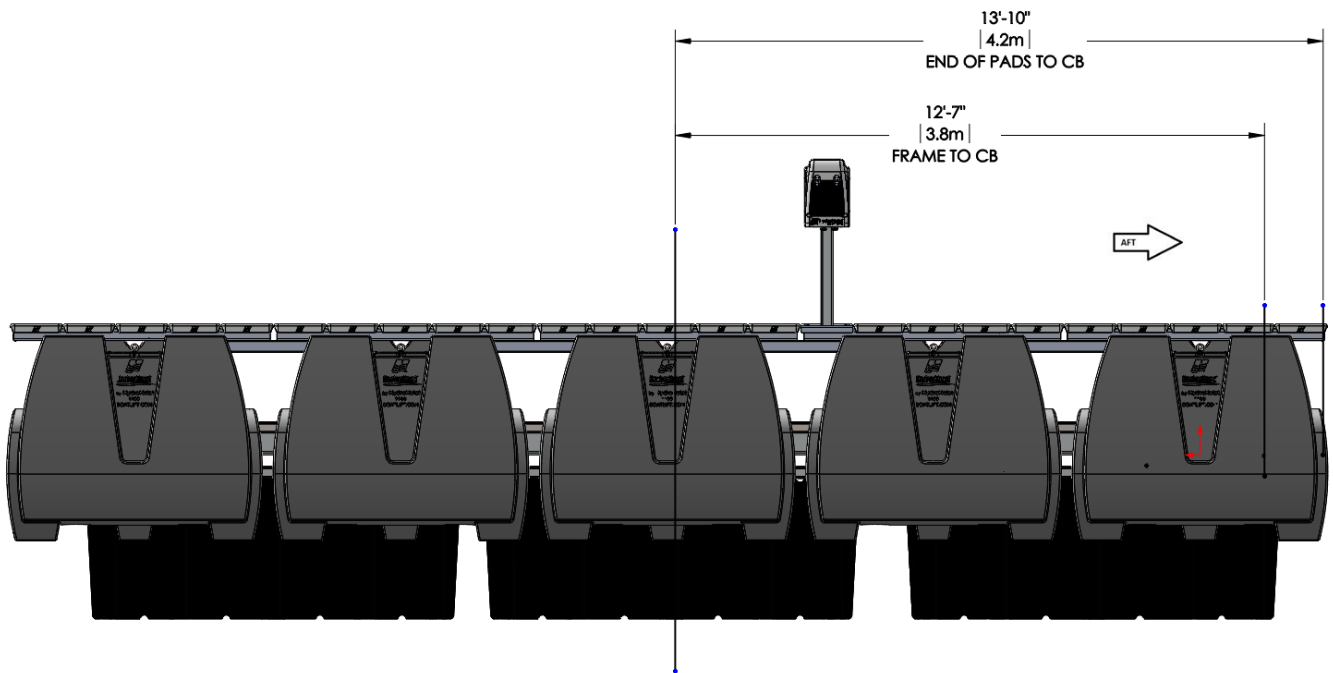

CB of 25000

Preventative Maintenance

Because of the harsh environments in which the HarborHoist can be installed, it is very important to inspect your HarborHoist occasionally to ensure it is at peak performance. Operate properly on a monthly basis to inspect and ensure the following:

- GFCI trips and resets properly when the TEST and RESET buttons are pressed
- All air hoses are firmly attached, clamps are tight, and there are no apparent leaks
- All the aluminum components are structurally sound and no heavy corrosion is visible
- The hull pads (if equipped) are structurally sound with no severe cracking or damage
- All mounting / attachment brackets are secure
- If rope mooring is used, inspect the ropes for any issues that may compromise the integrity
- Most importantly, run your blower motor at least once a month even during the off-season. Press **RAISE** button on the control and let it run about 1 minute to help keep the motor contacts and brushes clean
- Verify the level sensor is attached to the frame, is secure, and the cable is free of damage that could cause issues with the electrical communication to the control
- It is recommended to power wash your lift monthly to keep it clean and free of vegetation or organism growth

Boat Fitment

Take care to clear shafts, thru hull fittings, chines, etc. Keel of boat must NOT rest on cross beam and should clear the beam by at least 1 inch. Center of gravity (CG) of the boat, must be in the center of the lift (unless auxiliary tanks are used) bow to stern and port to starboard. This will evenly distribute the load over the lift, allowing for maximum lift height and maintain the appearance of the lift floating level.

It is the responsibility of the End User to insure that:

- The lift is installed by a certified HydroHoist Installer
- The lift is operated in a safe manner
- Regular inspection is made of the lift components
- All safety and warning labels are understood

No alterations or modifications may be made to the HydroHoist equipment without the express written consent of HydroHoist, LLC. Re-installation, adjusting the bunks, and or adjusting the tank beam spacing of the equipment must be performed to the standards set forth by HydroHoist, LLC. It is the obligation of the end user to inform all equipment operators of the above conditions. Owners Manuals and Safety Warning Decals are available on request from HydroHoist, LLC.



Warranty and Registration

What Is Not Covered By This Warranty.

- HydroHoist® does not warrant any product, component, or part
 - (a) That is not manufactured by HydroHoist®
 - (b) **That is not installed or serviced by employees or contractors of HydroHoist® or an Authorized HydroHoist® Dealer**
 - (c) Damage caused by failure to provide a suitable installation environment for the lift
 - (d) Damage caused by the use of the lift for purposes other than those for which it was designed
 - (e) Damage caused by disaster such as fire, flood, wind, and lightning
 - (f) Damage caused by unauthorized attachments or modification
 - (g) Damage caused by operation, maintenance, or repair of the product contrary to written instructions from HydroHoist®
 - (h) Damage during shipment
 - (i) Damage caused by any other abuse or misuse by the Consumer
 - (j) Which has an altered or defaced serial number

Parts and Customer Service Contact

- Customer service, parts, and shipping: customerservice@boatlift.com

Product Registration



Verify that your authorized HydroHoist dealer did register your HarborHoist product. If the lift is not registered, warranty support may be limited. Go to www.boatlift.com to register your lift.

Appendix A

Power Requirements:

Part number	Control Description	Voltage requirement	Amperage Service Requirement
1035232	HarborHoist Triton 4 Valve Single Blower -110	110 VAC	20 amp
1035233	HarborHoist Triton 5 Valve Single Blower -110	110 VAC	20 amp
1035234	HarborHoist Triton 6 Valve Single Blower -110	110 VAC	20 amp
1035235	HarborHoist Triton 6 Valve Dual Blower -110	110 VAC	30 amp
1035238	HarborHoist Triton 4 Valve Single Blower -220	220 VAC	20 amp
1035240	HarborHoist Triton 5 Valve Single Blower -220	220 VAC	20 amp
1035242	HarborHoist Triton 6 Valve Single Blower -220	220 VAC	20 amp

