

Section 1078

**SECTION 1078
PRESTRESSED CONCRETE MEMBERS**

1078-1 GENERAL

This section covers the materials for and the production of precast, prestressed concrete members produced in accordance with the contract.

Use prestressing of the pretensioning type in which steel prestressing strands are initially stressed and anchored; the concrete is then placed, vibrated and cured; and when the concrete reaches the required strength, the load is transferred from the anchorages to the concrete.

The intent of this section is to require the producer to provide prestressed concrete members that meet the *Standard Specifications* and exhibit characteristics that are not objectionable to the Department.

(A) Producer Qualification

Producers of precast, prestressed concrete members are required to establish proof of their competency and responsibility in accordance with the Precast/Prestressed Concrete Institute’s (PCI) Plant Certification Program to perform work for the project. Certification of the manufacturing plant under the PCI program and submission of proof of certification to the State Materials Engineer is required before beginning fabrication. Maintain certification at all times while work is being performed for the Department. Submit proof of certification following each PCI audit to the State Materials Engineer for continued qualification. These same requirements apply to producers subcontracting work from the producer directly employed by the Contractor.

Employ producers PCI certified in Product Group B, Bridge Products and in one of the appropriate categories as listed below:

- (1) B2 Prestressed Miscellaneous Bridge Products includes solid piles, sheet piles and bent caps;
- (2) B3 Prestressed Straight-Strand Bridge Members includes all box beams, cored slabs, straight-strand girders and bulb-tees, bridge deck panels, hollow piles, prestressed culverts and straight strand segmental components; or
- (3) B4 Prestressed Deflected-Strand Bridge Members includes deflected strand girders and bulb-tees, haunched girders, deflected strand segmental superstructure components and other post-tensioned elements.

Categories for elements not listed above will be as required by the project special provision or plans.

(B) Working Drawing Submittals

Before casting girders, submit complete working drawings to the Engineer for approval. The drawings shall detail the exact location and description of all casting holes, attachments and inserts cast in the member for both temporary and permanent applications. The casting holes, attachments and inserts are in association with, but not limited to: fall protection, overhang falsework, metal stay-in-place forms, solar platforms, temporary girder bracing, transit, erection, lifting and handling. If the plan notes indicate that the structure contains the necessary corrosion protection required for a corrosive site, epoxy coat, galvanize or metalize all metallic components except stainless steel and malleable iron components. Electroplating will not be allowed.

1078-2 MATERIALS

Refer to Division 10.

Item	Section
Air Entraining Agent	1024-3

Item	Section
Chemical Admixtures	1024-3
Coarse Aggregate	1014-2
Epoxy Protective Coating	1081-1
Fine Aggregate	1014-1
Fly Ash	1024-5
Ground Granulated Blast Furnace Slag	1024-6
Miscellaneous Metals	1074
Portland Cement	1024-1
Prestressing Strand	1070-5
Reinforcing Steel	1070
Type IP Blended Cement	1024-1
Type IS Blended Cement	1024-1
Silica Fume	1024-7
Structural Steel	1072
Water	1024-4

1 Do not make changes in the source of aggregates, cements or admixtures during the casting of
 2 members in any one span or substructure unit unless approved by the Engineer.

3 **1078-3 INSPECTION**

4 The Department reserves the right to place a duly authorized inspector in the plant at any or
 5 all times work related to the production of members for the Department is performed. Notify
 6 the Engineer at least 7 days in advance when such work is scheduled. Provide an office area
 7 with an approximate floor space of 100 sf, a desk or drafting table, 2 chairs, telephone,
 8 separate dial-up or faster internet access, facilities for proper heating and cooling and
 9 adequate lighting at the plant for the exclusive use of the inspector. The inspector has the
 10 authority to reject any or all members not manufactured in accordance with these *Standard*
 11 *Specifications*. Approval of any member by the inspector at the plant is in no way final, and
 12 further inspection is made at the structure site both before and after the member is placed in
 13 the final position. Any member found to be defective in any manner at any time is rejected
 14 and requires replacement by an acceptable member or repair in a manner approved by the
 15 Engineer.

16 Do not transport any member from the plant to the job site before approval of that member by
 17 the plant inspector. Provide access to all surfaces of the member so the plant inspector has the
 18 opportunity to properly inspect the member before approval. This approval is stamped on the
 19 member by the plant inspector.

20 **1078-4 PORTLAND CEMENT CONCRETE**

21 **(A) Composition and Design**

22 Supply Portland cement concrete composed of Portland cement, coarse aggregate, fine
 23 aggregate, water and an approved air-entraining agent. Add other cementitious materials
 24 and/or chemical admixtures if approved by the Engineer. When admixtures are used, use
 25 them in the proper proportions to obtain the optimum effect. Do not use set accelerating
 26 admixtures, calcium chloride or admixtures containing calcium chloride. If approved,
 27 high range water reducer may be used at a rate not to exceed the manufacturer's
 28 recommended dosage.

Section 1078

- 1 Supply concrete with a minimum compressive strength of 5,000 psi at the age of 28 days,
- 2 unless otherwise required by the plans or Specifications. Ensure that all coarse aggregate
- 3 used in prestressed concrete passes a 1" sieve. Maintain a cement content of at least
- 4 564 lb/cy but no more than 752 lb/cy. As an option, reduce the cement content of the mix
- 5 design and replace with fly ash or ground granulated blast furnace slag in accordance
- 6 with Article 1024-1. For concrete with a 28 day design strength greater than 6,000 psi, if
- 7 approved, substitute microsilica for cement, in conformance with Article 1024-1.
- 8 Supply concrete meeting Table 1078-1, unless otherwise approved by the Engineer.

TABLE 1078-1 REQUIREMENTS FOR CONCRETE		
Property	28 Day Design Compressive Strength 6,000 psi or less	28 Day Design Compressive Strength greater than 6,000 psi
Maximum Water/Cementitious Material Ratio	0.45	0.40
Maximum Slump without HRWR	3.5"	3.5"
Maximum Slump with HRWR	7"	7"
Air Content (upon discharge into forms)	5 + 2%	5 + 2%

9 Submit to the Engineer proposed concrete mix designs for each strength of concrete used
 10 in the work. Determine quantities of fine and coarse aggregates necessary to provide
 11 concrete in accordance with the *Standard Specifications* by the method described in
 12 ACI 211 using the absolute volume basis.

13 Submit mix designs, stated in terms of saturated surface dry weights, on
 14 M&T Form 312U at least 35 days before using the proposed mix. Adjust batch
 15 proportions to compensate for surface moisture contained in the aggregates at the time of
 16 batching. Changes in the saturated dry mix proportions are not permitted unless revised
 17 mix designs are submitted to the Engineer and are determined to be acceptable for use.

18 Provide with M&T Form 312U a listing of laboratory test results of aggregate gradation,
 19 air content, slump and compressive strength. List the compressive strength of at least
 20 three 6" x 12" or 4" x 8" cylinders. Show the age of the cylinders at the time of testing
 21 and a detailed description of the curing procedure. Perform laboratory tests in
 22 accordance with the following test procedures:

Property	Test Method
Aggregate Gradation	AASHTO T 27
Air Content	AASHTO T 152
Slump	AASHTO T 119
Compressive Strength	AASHTO T 23 and T 22

23 If the design 28 day compressive strength is greater than 6,000 psi, submit the
 24 compressive strength of at least 6 cylinders. Ensure that the average strength of the
 25 6 cylinders is at least 1,500 psi above the minimum 28 day compressive strength required
 26 by the plans.

27 When the combination of materials is such that the required strength and/or a workable
 28 slump is not obtained at the minimum specified cement content with the maximum
 29 allowable water-cement ratio, increase the cement content at no cost to the Department
 30 by whatever amount is required to produce the required strength and/or slump without
 31 exceeding the allowable water-cement ratio.

1 The Engineer reviews the mix design only to ascertain general compliance with the
2 *Standard Specifications*. The Engineer notifies the Contractor, in writing, that the mix
3 design is either acceptable or unacceptable. Do not use a mix until notified by the
4 Engineer that the mix design is acceptable. Acceptance of the mix design does not
5 relieve the Contractor of responsibility to furnish an end product meeting specification
6 requirements. Upon request, a mix design accepted and used satisfactorily on any
7 Department project may be accepted for use on other projects.

8 **(B) Testing**

9 Employ a certified concrete technician to perform all testing required by this subarticle at
10 the bed site in the presence of the plant inspector unless otherwise approved.
11 Certification of technicians is awarded upon satisfactory completion of examinations
12 prepared and administered by the Department or other approved agency.

13 (1) Air Content

14 Before allowing placement of the first load in a bed, determine the air content by
15 a calibrated Chace indicator in accordance with AASHTO T 199. During the
16 placement of the first load, determine the air content by AASHTO T 152, T 196 or
17 T 121. Determine the air content in each subsequent 10 cy by the Chace indicator in
18 accordance with AASHTO T 199 before allowing placement. Determine the air
19 content by AASHTO T 152, T 196 or T 121 from all loads from which cylinders are
20 made. If the air content as determined by the Chace indicator, AASHTO T 199, fails
21 to meet the specification requirements, a second test is run on material from the same
22 load and the results of the 2 tests averaged. If the average does not meet the
23 *Standard Specifications*, a test on the same load is conducted using AASHTO T 152,
24 T 196 or T 121. Acceptance or rejection of the load is based on the results of this
25 test.

26 (2) Slump

27 Determine slump in accordance with AASHTO T 119.

28 (3) Strength

29 For the purpose of testing for the required 28 day compressive strength and also for
30 the required compressive strength for the transfer of load, furnish, at no cost to the
31 Department, cylinders made from a sample of concrete placed near the live end of
32 the bed and additional cylinders made from a sample of concrete placed near the
33 dead end of the bed. Make cylinders in accordance with AASHTO T 23, except cure
34 the cylinders in the same manner as the members represented until the strands are
35 released. Place cylinders in clusters at random points along the casting bed. After
36 the strands are released, air cure the cylinders in an approved common area near the
37 testing apparatus for the remainder of the 28 day curing period. Test the cylinders in
38 accordance with AASHTO T 22. Provide approved apparatus for testing the transfer
39 strength of the cylinders. Maintain this apparatus to within 1.0% accuracy and
40 calibrate at intervals not to exceed 12 months by an approved testing company at no
41 cost to the Department. The Engineer reserves the right to require verification
42 immediately after a testing machine is relocated and whenever there is reason to
43 doubt the accuracy of the indicated load, regardless of the time interval since the last
44 verification.

Section 1078

1 The testing requirements vary according to the 28 day compressive strength required
2 by the plans as follows:

3 (a) Compressive Strength (28 day) of 6,000 psi or Less

4 Test 2 cylinders, one from each end of the bed, for the purpose of determining
5 whether the concrete has reached the required strength for transfer of load.
6 Ensure that the average of the strength tests on the 2 cylinders meets or exceeds
7 the required strength and the lowest cylinder is not more than 200 psi below the
8 required strength.

9 Test 2 cylinders to determine compressive strength at the age of 28 days. The
10 strength from these 2 cylinders is averaged. Ensure that this average is at least
11 5,000 psi or such 28 day compressive strength required by the plans or *Standard*
12 *Specifications*. Ensure that no cylinder indicates a compressive strength less
13 than 400 psi below the required 28 day compressive strength. Failure to meet
14 the above requirements is cause for rejection of the members represented.

15 (b) Compressive Strength (28 day) of Greater Than 6,000 psi

16 Test 4 cylinders, 2 from each end of the bed, for the purpose of determining
17 whether the concrete has reached the required strength for transfer of load. The
18 strengths from the dead end cylinders are averaged and the strengths from the
19 live end cylinders are averaged. Ensure that both of these averages meet or
20 exceed the required release strength and the lowest cylinder is not more
21 than 200 psi below the required strength.

22 Test 3 cylinders from each end to determine the 28 day compressive strength.
23 The strengths from the dead end cylinders are averaged and the strengths from
24 the live end cylinders are averaged. Ensure that both of these averages meet or
25 exceed the 28 day compressive strength. Ensure that no cylinder indicates
26 a compressive strength less than 400 psi less than the required 28 day
27 compressive strength. Failure to meet the above requirements is cause for
28 rejection of the members represented.

29 **(C) Temperature Requirements**

30 Maintain a concrete temperature at the time of placing in the forms between 50°F
31 and 95°F.

32 Do not place concrete when the air temperature, measured at the location of the
33 concreting operation in the shade away from artificial heat, is below 35°F.

34 **(D) Elapsed Time for Placing Concrete**

35 Ensure that the elapsed time for placing concrete is in accordance with
36 Subarticle 1000-4(E). The requirements of Subarticle 1000-4(E) pertaining to
37 Class AA concrete apply to prestressed concrete.

38 **(E) Use of Set Retarding Admixtures**

39 By permission of the Engineer, use an approved set retarding admixture if choosing to
40 take advantage of the extended time interval between adding mixing water and placing
41 the concrete.

42 Use a quantity of set retarding admixture per 100 lb of cement within the range
43 recommended on the current list of approved set retarding admixtures issued by the
44 Materials and Tests Unit.

45 **(F) Use of Water Reducing Admixtures**

46 Use water-reducing admixtures in accordance with Subarticle 1000-4(G).

(G) Use of Calcium Nitrite Corrosion Inhibitor

Add an approved calcium nitrite corrosion inhibitor (30% solids) to the concrete mix at the batch plant for the bridge elements identified by the plan notes. Clearly mark the prestressed concrete members that contain calcium nitrite.

Use the inhibitor at a minimum rate of 3.0 gal/cy. Ensure that the hardened concrete contains at least 5.1 lb/cy Nitrite (NO₂) when tested in accordance with Materials and Tests Method Chem. C-20.0 with the exception of concrete used in prestressed members. Test prestressed members as follows:

The Department will perform the complete C-21.0 Field Test Procedure for the Nitrite Ion in Plastic Concrete on plastic concrete samples obtained randomly from a truck used to pour concrete near each end (live end and dead end) of a prestressed concrete casting. Powder samples will be taken from hardened cylinders made at the time C-21.0 is run for any concrete that fails the C-21.0 (plastic test) method. The Chemical Testing Laboratory will test the powder using method C-20.0 Determination of Nitrite in Hardened Concrete. Acceptance of the concrete is dependent in the results of method C-20.0 (hardened test) when any sample fails the C-21.0 (plastic test method).

The Department will perform a qualitative nitrite ion check by method C-22.0 (Field Spot Test) on each load of concrete batched for a prestressed concrete casting bed. Acceptance of the concrete is dependent on the results of method C-20.0 (hardened test) when any sample fails the C-22.0 (Field Spot Test). The producer may elect to not incorporate concrete that fails Method C-22.0 (Field Spot Test) instead of waiting for C-20.0 (hardened test) test results to determine the acceptability of the member. Once per each week's production of prestressed concrete with corrosion inhibitor, random samples of hardened concrete powder will be taken from cylinders used for method C-21.0 (plastic test). These samples will be submitted to the Chemical Testing Laboratory for analysis using method C-20.0 (hardened test).

Units with calcium nitrite in a quantity less than specified are subject to rejection. Furnish concrete cylinders to the Engineer, in a quantity to be specified, to verify the concentrations of calcium nitrite in hardened concrete. Concrete failing to contain calcium nitrite at the required concentrations as tested is subject to rejection.

Use only air-entraining, water-reducing and/or set-controlling admixtures in the production of concrete mixtures that are compatible with calcium nitrite solutions.

Strictly adhere to the manufacturer's written recommendations regarding the use of admixtures including storage, transportation and method of mixing. If preferred, use calcium nitrite, which acts as an accelerator, in conjunction with a retarder to control the set of concrete, as per the manufacturer's recommendation.

(H) Measuring Materials

Measure materials in accordance with Article 1000-8.

(I) Mixers and Agitators

Use mixers and agitators meeting Article 1000-10.

Section 1078

1 (J) Mixing and Delivery

2 (1) General

3 Mix and deliver concrete to the site of the work by one of the following methods,
4 except where other methods are approved by the Engineer. The Engineer approves
5 the mixing of concrete by methods other than those listed below provided the
6 proposed method is capable of satisfying job requirements and there is adequate
7 evidence that the proposed method produces concrete complying with the *Standard*
8 *Specifications*. Assume responsibility for controlling the materials and operations so
9 as to produce uniform concrete meeting the *Standard Specifications*.

10 Have present during all batching operations at the concrete plant a certified concrete
11 technician employed by the Contractor, prestressed concrete producer or concrete
12 supplier while concrete is batched and delivered to the site of the work. The sole
13 duty of this employee is to have charge of and exercise close supervision of the
14 production and control of the concrete. Ensure the technician performs moisture
15 tests, adjusts mix proportions of aggregates for free moisture, completes batch tickets
16 on M&T Form 903 or approved delivery tickets, signs batch tickets or approved
17 delivery tickets and assures quality control of the batching operations. Delivery
18 tickets are permitted instead of batch tickets on M&T Form 903 provided they are
19 reviewed and approved by the Materials and Tests Unit. Certification of technicians
20 is awarded upon satisfactory completion of examinations prepared and administered
21 by the Department or other approved agency.

22 (a) Central Mixed Concrete

23 Mix completely in a stationary mixer and transport the mixed concrete to the
24 point of delivery in a truck agitator or in a truck mixer operating at agitating
25 speed or in non-agitating equipment approved by the Engineer. Mix within the
26 capacity and at the mixing speeds recommended by the equipment
27 manufacturer.

28 (b) Transit Mixed Concrete

29 Mix completely in a truck mixer while at the batching plant, in transit or at the
30 work site.

31 (2) Mixing Time for Central Mixed Concrete

32 The mixing time starts when all the solid materials are in the mixing compartment
33 and ends when any part of the concrete begins to discharge. Charge the ingredients
34 into the mixer such that some of the water enters in advance of cement and
35 aggregate, and substantially all the water is in the drum before 1/3 of the specified
36 mixing time elapses. Transfer time in multiple drum mixers is counted as part of the
37 mixing time.

38 Establish the minimum mixing time by one of the following:

39 (a) Mixer performance tests as described herein,

40 (b) The manufacturer of the equipment, or

41 (c) The requirement of one minute for mixers of 1.0 cy capacity or less with
42 an increase of 15 seconds for each cubic yard or fraction thereof in increased
43 capacity.

44 The Engineer reserves the right to require a mixer performance test at any time. The
45 minimum mixing time as determined by the mixer performance test is that which
46 produces concrete in accordance with Table 1078-2.

1 Sample and test for mixer performance as provided below. Charge the mixer to its
 2 rated capacity with the materials and proportions used in the work and mix at the
 3 recommended mixing speed to the target time. Stop mixing then and begin
 4 discharging. Take 2 samples of sufficient size to make the required tests after
 5 discharge of approximately 15% and 85% of the load by an appropriate method of
 6 sampling which provides representative samples of the concrete.

7 Separately test each of the 2 samples of concrete for the properties listed in
 8 Table 1078-2. Conduct tests in accordance with the standard methods shown in
 9 Table 1078-2 or procedures established by the Materials and Tests Unit.

10 Perform the mixer performance test described above on at least 2 batches of
 11 concrete. For the performance test to be acceptable, ensure that all tests in each
 12 batch meet the requirements listed above.

13 The Engineer rechecks mixer performance at any time when in his judgment
 14 acceptable mixing is not accomplished.

15 Where acceptable mixing cannot be accomplished in the established mixing time, the
 16 Engineer increases the mixing time or requires that the mixer be repaired or replaced
 17 before any further mixing.

18 (3) Truck Mixers and Truck Agitators

19 Use truck mixers and truck agitators meeting Subarticle 1000-11(C). For concrete
 20 with a design 28 day compressive strength greater than 6,000 psi, load trucks to
 21 within 1 cy of rated capacity and mix at a speed of 16 to 18 rpm.

22 (4) Delivery

23 For central mixed concrete delivered in truck agitators, truck mixers, or transit mixed
 24 concrete, use a ticket system for recording the transportation of batches from the
 25 proportioning plant to the site of the work. Fill out the tickets on M&T Form 903 or
 26 approved delivery tickets in accordance with the instructions issued by the Engineer.
 27 Issue the tickets to the truck operator at the proportioning plant for each load and
 28 have them signed by the certified concrete technician, which signifies that the
 29 concrete in the truck is inspected before departure. Show on each ticket the time
 30 batching is complete and if transit mixed, the number of revolutions at mixing speed,
 31 if any, at the plant. Deliver the tickets to the inspector at the site of the work. For
 32 central mixed concrete delivered in non-agitating equipment, alternate methods of
 33 documenting batch proportions are considered by the Engineer. Loads that do not
 34 arrive in satisfactory condition within the time limits specified are not acceptable for
 35 use in the work.

36 (K) Ready Mixed Concrete Plant

Property	Requirement	Test Method
Difference in Test Samples Air Content, Percent by Volume of Concrete	1.0%	AASHTO T 152
Slump	1.0"	AASHTO T 119
Coarse aggregate content, portion by weight of each sample retained on the No. 4 sieve	6.0%	-
Weight per Cubic Foot (Density)	1.0 lb/cf	AASHTO T 121
Average Compressive Strength at 7 days, Percent of Average	7.5% ^A	AASHTO T 22 and T23

37 **A.** Obtain tentative approval pending 7 day compressive strength tests.

Section 1078

1 Ensure ready mixed concrete plants are inspected and approved by the Department before
2 they are used to produce concrete for the project. Ensure that plants meet all applicable
3 requirements of the *Standard Specifications* and in addition have at least 2 acceptable
4 concrete delivery vehicles that are in working condition. Plants approved by the
5 Department are placed on a list of approved plants that is made available. All plants are
6 subject to reinspection at intervals selected by the Engineer. Reapproval after each
7 inspection is contingent on continuing compliance with the *Standard Specifications*

8 **1078-5 CASTING BED AND FORMS**

9 Use metal forms, including headers or end forms, except where other materials are approved
10 by the Engineer. Use forms of adequate thickness, braced, stiffened, anchored and aligned
11 adequately to consistently produce members within the limits of dimensional tolerances.
12 Design and align the forms so they do not restrict longitudinal movement of the casting when
13 the prestressing force is transferred. Provide corners and angles that are chamfered or
14 rounded. Provide joints in forms that are smooth and tight enough to prevent leakage of
15 mortar. Plug holes and slots in forms, pallets, headers and bulkheads neatly to prevent
16 leakage of mortar. Make the inside surfaces of forms accessible for cleaning. Thoroughly
17 clean the beds and forms after each use. Before casting, clean the inside surfaces of the forms
18 from rust, grease or other foreign matter. Remove all foreign substances from inside the
19 forms, including any standing water. Do not allow coatings used for release of members to
20 build up. Do not use forms that do not present a smooth surface.

21 When casting holes through the top flange of Bulb Tee Girders for overhang or interior bay
22 falsework hanger rods, use rigid PVC conduits with a wall thickness of approximately 1/8".
23 Do not use thin wall material. Secure conduits in the forms so they do not migrate out of the
24 proper location. Other methods of forming holes may be proposed but are subject to the
25 Engineer's approval.

26 When casting dowel rod holes in cored slab or box beam members, use material that creates
27 round, vertical holes of the specified diameter and in the correct location. Do not use material
28 that deforms, collapses or shifts position during casting of the member.

29 Apply form release agents to the forms either before or after stringing of strands. If applied
30 before stringing, provide a release agent of a type that dries to a degree so it cannot
31 contaminate any strand that comes in contact with it. If the release agent is applied after
32 stringing, exercise great care and provide a sheet metal or similar type shield for protection of
33 the strands.

34 **1078-6 TENSIONING DEVICES**

35 Use tensioning devices adequate to produce and maintain the required tension in all strands
36 until the concrete reaches the required transfer strength. Equip all jacks with accurate and
37 calibrated gauges for registering jacking loads. Calibrate gauges with the jacks with which
38 they are used. Calibrate all jacks and gauges by an approved testing company at no cost to the
39 Department at intervals not to exceed 12 months. During progress of the work, if gauge
40 readings and elongations indicate materially differing loads, recalibrate as required. Use
41 gauges with a full load capacity of 1 1/2 to 2 times their normal working load, unless
42 otherwise approved. Do not use loads less than one-fourth or more than 3/4 of the total
43 graduated gauge capacity unless calibration data clearly establishes consistent accuracy over
44 a wider range. Use gauges with indicating dials at least 6" in diameter and gauge pointers that
45 do not fluctuate, preventing an accurate reading, but remain steady until the jacking load is
46 released. Ensure that all gauges have an accuracy of reading within 2%. Provide means for
47 measuring the elongation of strands within 1/4".

1 1078-7 PLACING STRANDS, TIES AND REINFORCING STEEL

2 Position strands, ties, supports, reinforcing bars of the sizes shown in the plans and bearing
3 plates in accordance with the detailed dimensions shown in the plans and effectively secure
4 against displacement from their correct positions. The use of previously tensioned strands is
5 not permitted. For prestressing strands, do not allow deflections or displacements of any kind
6 between the end anchorages unless shown in the plans. Place the steel reinforcing in final
7 position after tensioning of the strands. Bend all tie wires to the inside of the member so the
8 ends are farther from the edge than the material tied. Support bottom strands spacings not to
9 exceed 20 ft by supports meeting Article 1070-4 or by other approved means. Plastic
10 supports may be used when approved.

11 Strands with kinks, bends, nicks, scale, excessive rust or other defects are not permitted. No
12 more than one broken wire per casting bed is permitted. Slight rusting is not cause for
13 rejection, provided it is not sufficient to cause visible pits. Take precautions to prevent
14 contamination of strands and reinforcing steel. Clean the strands and reinforcing steel to an
15 acceptable condition before pouring concrete. Do not place concrete in the forms until the
16 strand and reinforcement condition and arrangement are inspected by the plant inspector.

17 Strand splices are only permitted at the end of a reel and when using a single strand jack.
18 Ensure that the strand lengths to be spliced together have the same lay of wire to avoid
19 unraveling and position the splice so it does not fall within a member. Do not torch cut the
20 ends of the spliced strand lengths. Cut by shears, abrasive grinders or other means approved
21 by the Engineer. No more than one strand splice per bed is allowed on an individual strand
22 and the use of previously tensioned strands for splicing is not permitted.

23 Where debonding of strands is required, accomplish by encasing the strand in a tubular
24 conduit capable of resisting the pressure exerted by the concrete. Do not use slit conduit. Use
25 a conduit of HDPE or polypropylene with a minimum wall thickness of 0.025". Ensure that
26 the inside diameter of the conduit is of sufficient size to allow free movement of the encased
27 strand but not greater than the diameter of the strand plus 1/8". Secure the conduit so
28 longitudinal movement along the strand is prevented, and bonding of the strand is prevented
29 at the required location ± 1 ". Prevent concrete from entering the conduit by taping. Use tape
30 manufactured from a non-corrosive material compatible with the concrete, conduit and steel.

31 1078-8 TENSIONING PROCEDURE

32 A producer quality control representative shall be present during strand tensioning. Tension
33 each strand to the load shown in the plans before placing the concrete.

34 Measure the load induced in the prestressing strand both by jacking gauges and strand
35 elongations on at least the first 5 strands and every third strand thereafter on each pour.
36 Measure loads on all other strands by either jacking gauges or strand elongations. When both
37 methods of measurement are used, if a discrepancy between gauge and elongation of more
38 than 5% is apparent, carefully check the entire operation and determine the source of error
39 before proceeding. Make appropriate allowances in the computed elongation and jacking
40 loads for load losses due to friction and all possible slippage or relaxation of the anchorage.
41 Establish references periodically at each strand anchorage to indicate any yielding or slippage
42 that may occur between the time of initial tensioning and final release of the strands.

43 In determining the applied load by measuring the elongation of the strand, use a modulus of
44 elasticity taken from the typical stress-strain curve for the brand, size and type of strand
45 tensioned. Submit stress-strain curve data for the actual heats of material used in the strands
46 to the plant inspector before using the strands. Identify each reel or strand by tagging in
47 accordance with AASHTO M 203. Mark the outer layer of each reel pack of strand with a
48 wide color band as follows: white for 270K stress relieved strand, green for low relaxation
49 strand and a double marking of green and red for special low relaxation strand. In addition,
50 attach a metal tag to each reel pack labeled in accordance with AASHTO M 203.

Section 1078

1 Tension strands in a group or individually. Before full tensioning, bring each strand to
2 an initial tension of 2,000 lb for all beds under 150 ft in length, 3,000 lb for all beds 150 ft to
3 300 ft in length and 4,000 lb for all beds longer than 300 ft in length. Measure this initial
4 tension by a calibrated gauge or other approved means, and then compute the elongation due
5 to initial tensioning. Use the difference between the required final tension and the initial
6 tension to compute the expected additional elongation.

7 For precast prestressed deck panels, use a final prestressing force of 14,000 lb per strand for
8 Grade 250 strand and 16,100 lb per strand for Grade 270 strand.

9 After initial tensioning, tension the strands until the required elongation and jacking load are
10 attained and reconciled within the limits specified above. Keep a permanent record of the
11 initial jacking load, the final jacking load, and the elongation produced thereby.

12 In single strand tensioning, rotation of the jacking ram is not allowed.

13 When draped strands are used, submit 6 sets of the bed layout showing the method of draping
14 and tensioning the draped strands and also calculations determining the loads required for
15 tensioning the draped strands. Drape the strands for all members to be cast in any one
16 tensioning operation before casting any beam. Have end templates or bulkheads at ends of
17 beams remain vertical or as otherwise shown in the plans. Perform draping for all members
18 either simultaneously or in single or incremental lifts beginning at the center of the bed and
19 working outward toward each end of the bed. Complete tensioning in the fully draped
20 position is not allowed unless approved in writing.

21 Use round steel rollers of a type and dimensions approved by the Engineer for deflecting the
22 draped strands. Round the part in contact with the strand to a diameter of not less than 3/4".
23 Use support and hold-down devices of sufficient rigidity with adequate support so the final
24 position of the strands is as shown in the plans.

25 With strands tensioned in accordance with the above requirements and with other
26 reinforcement in place, cast the concrete members so as to achieve the required lengths.
27 Maintain strand load between anchorages until the concrete reaches the required compressive
28 strength for transfer of load from the anchorages to the members.

29 For personnel engaged in the tensioning operation, provide protection by effective shields
30 adequate to stop a flying strand. Provide shields produced from steel, reinforced concrete,
31 heavy timbers and other approved material at both ends of the bed.

32 **1078-9 PLACING CONCRETE**

33 Place concrete in accordance with Article 1077-8 and the additional requirements of this
34 article.

35 Upon completion of stressing strand, place concrete within a reasonable time to prevent
36 contamination of the strands and reinforcing steel.

37 Place concrete for girders 54" or less in height, and concrete for all cored slabs and box
38 beams, in 2 or more equal horizontal layers. Place concrete for girders over 54" in height in
39 3 horizontal layers. When placing concrete in 3 layers locate the top of the first layer
40 approximately at the top of the bottom flange and locate the top of the second layer
41 approximately at the top of the web. To prevent separation of surfaces between layers, do not
42 allow the time between successive placements onto previously placed concrete to exceed
43 20 minutes, unless the previously placed concrete has not yet stiffened, as evidenced by the
44 continuous effective use of vibration. Should shrinkage or settlement cracks occur, the
45 Engineer reserves the right to require additional layers and/or vibration.

46 The requirement of the above paragraph may be waived with the permission of the Engineer if
47 self consolidating concrete is used.

48 Internal or a combination of internal and external vibration is required as is necessary to
49 produce uniformly dense concrete without honeycomb.

- 1 Place concrete in cold weather in accordance with Article 420-7.
- 2 Place concrete in daylight unless an adequate lighting system meeting the approval of the
3 Engineer is provided.
- 4 Do not exceed a temperature of 95°F in the freshly mixed concrete when placed in the forms.
- 5 Place the concrete in the bed in one continuous operation, finishing each member before
6 proceeding to the next one. If the pour stops before the concrete in all the members in the bed
7 is placed, start curing immediately. Do not place concrete in any remaining members in that
8 bed setup once curing at elevated temperatures has begun.
- 9 When cored slabs and box beams are cast, employ an internal hold-down system to prevent
10 the voids from moving. At least 6 weeks before casting cored slabs or box beams, submit to
11 the Engineer for review and comment, detailed drawings of the proposed void material and
12 hold-down system. In addition to structural details, indicate the location and spacing of the
13 holds-downs. Submit the proposed method of concrete placement and of consolidating the
14 concrete under the void.

15 **1078-10 CURING CONCRETE**

16 **(A) General**

17 Cure concrete by steam curing, radiant heat curing or water curing, as set forth below.
18 As an option, cure concrete for prestressed piles with membrane curing compound as set
19 forth below. Use a method or methods that prevent the concrete from losing moisture at
20 any time before curing is complete. Use methods that do not deface or injure the
21 concrete. Use curing procedures that prevent cracks from occurring in the members.
22 Cure all members in any one bed by the same method.

23 Continue the curing period until the concrete reaches sufficient strength to permit transfer
24 of load from the anchorage to the members. As soon as the concrete attains release
25 strength, immediately release all forms in a continuous operation, without delay for other
26 activities such as the cleaning of forms. Immediately following the removal of the forms,
27 de-tension the members.

28 **(B) Curing at Elevated Temperatures**

29 Perform radiant heat curing under a suitable enclosure that contains the heat and prevent
30 moisture loss. Apply moisture by a cover of moist burlap, cotton matting, or similar
31 approved material. Retain moisture by covering the member with an approved
32 waterproof sheeting in combination with an insulating cover. Support the cover at
33 a sufficient distance above the member being cured to allow circulation of the heat.

34 Provide steam curing enclosures essentially free of steam leakage to minimize moisture
35 and heat losses. Do not allow the enclosure to come in contact with the members or
36 forms for the members. Do not direct steam jets on the forms so as to cause localized
37 high temperatures.

38 After placing and vibrating, allow the concrete to attain its initial set before the
39 application of heat or steam. The concrete is considered to obtain its initial set when it
40 has a penetration resistance of at least 500 psi when tested in accordance with
41 AASHTO T 197. Take the sample of concrete tested for penetration resistance from the
42 last load cast in the bed. Store the sample of concrete with the precast member and
43 maintain in the same condition and environment as the member except for the periods of
44 time necessary to prepare the test specimen and to perform the penetration resistance test.
45 Conduct the penetration resistance test.

Section 1078

1 As an option, submit data indicating that an approved concrete mix attains its initial set
2 after some particular time period. Different periods may be required for different weather
3 conditions. If such data is submitted, consideration is given to permitting heat or steam
4 introduced after the time indicated by such data instead of having to perform the
5 penetration resistance test. Consideration is given to determining the time of initial set by
6 methods other than AASHTO T 197 provided data supporting such other methods is
7 submitted.

8 When the ambient air temperature is below 50°F, cover the forms after the placement of
9 concrete and apply sufficient heat to maintain the temperature of the air surrounding the
10 unit between 50° and 70°F.

11 When the ambient air temperature is above 70°F, start a water cure as set forth below or
12 other approved method as soon as the concrete is able to receive the water without
13 physical damage to its surface. Discontinuation of the cure is allowed upon introduction
14 of steam, provided that a relative humidity of 100% is maintained.

15 Cure at elevated temperatures at a temperature of not more than 160°F.

16 Maintain a relatively uniform rate of increase of the temperature within the curing
17 enclosure of approximately 40°F per hour, not to exceed 15°F per 15 minutes. Ensure
18 that the temperature increase is relatively uniform throughout the length and on both
19 sides and top of the concrete unit. Place recording thermometers within 50 ft of each end
20 of the bed and at points not to exceed 100 ft between the end thermometers. Provide at
21 least 2 thermometers for bed lengths of 100 ft or less. Calibrate recording thermometers
22 at intervals not to exceed 6 months. Ensure that the temperature differential within the
23 curing enclosure does not exceed 15°F. Submit complete temperature records for all
24 cures before final approval of the members.

25 Continue steam curing until the concrete reaches the required transfer strength.

26 (C) Water Curing

27 Keep the concrete continuously wet by the application of water as soon as possible
28 without damage to the concrete surface, and before the concrete obtains an initial set of
29 500 psi. Apply the water using soaker hoses and wet burlap or other approved means for
30 the full length of each member. Apply water evenly along the entire length of the bed.

31 When the ambient air temperature is below 50°F cover the forms after the placement of
32 the concrete and apply sufficient heat in an approved manner to maintain the temperature
33 of the air surrounding the member between 50°F and 70°F. After the concrete obtains
34 an initial set of 500 psi, the air temperature surrounding the member is allowed to
35 increase to 100°F while continually maintaining moisture on the surface of the concrete.
36 Whenever heat is applied to the member, place temperature recording clocks on the bed
37 as required when curing at elevated temperatures. The requirements for rate of
38 temperature increase apply.

39 Maintain the application of heat (if used) and water until the concrete obtains release
40 strength.

41 (D) Curing with Membrane Curing Compound

42 As an option, cure prestressed concrete piles with a membrane curing compound. Spray
43 the entire surface of the concrete uniformly with a wax-free, resin-base curing compound
44 conforming to Article 1026-2. Use clear curing compound to which a fugitive dye is
45 added for color contrast.

1 Apply the membrane curing compound after the surface finishing is complete, and
2 immediately after the free surface moisture disappears. In the event the application of
3 curing compound is delayed, start another curing method immediately and continue until
4 the application of the curing compound is started or resumed or until the concrete reaches
5 the required detensioning strength.

6 Seal the surface with a single uniform coating of the specified type of curing compound
7 applied at the rate of coverage recommended by the manufacturer or as directed by the
8 Engineer, but not less than one gallon per 150 sf of area.

9 At the time of use, thoroughly mix the compound in a condition with the pigment
10 uniformly dispersed throughout the vehicle. If the application of the compound does not
11 result in satisfactory coverage, stop the method and apply water curing, as set out above,
12 until the cause of the defective work is corrected.

13 At locations where the coating shows discontinuities, pinholes, or other defects, or if rain
14 falls on the newly coated surface before the film dries sufficiently to resist damage, apply
15 an additional coat of the compound immediately after the rain stops at the same rate
16 specified herein.

17 When the ambient air temperature is below 50°F, cover the forms after the application of
18 the curing compound and apply sufficient heat in an approved manner to maintain the
19 temperature of the air surrounding the member between 50°F and 70°F. Whenever heat
20 is applied to the members, place recording thermometers on the bed as required when
21 curing at elevated temperatures. The requirements for rate of temperature increase also
22 apply.

23 Completely remove any curing compound adhering to a surface to which new concrete is
24 bonded by sandblasting, steel wire brushes, bush hammers or other approved means.

25 Protect the concrete surfaces to which the compound is applied from abrasion or other
26 damage that results in perforation of the membrane film until the concrete achieves
27 design strength and the members are de-tensioned.

28 **1078-11 TRANSFER OF LOAD**

29 A producer quality control representative or equivalent qualified personnel shall be present
30 during removal of forms and during transfer of load.

31 Transfer load from the anchorages to the members when the concrete reaches the required
32 compressive strength shown in the plans. Loosen and remove all formwork in one continuous
33 operation as quickly as possible as soon as release strength is obtained. As soon as the forms
34 are removed, and after the Department's Inspector has had a reasonable opportunity to inspect
35 the member, transfer the load from the anchorages to the members as quickly as possible in
36 one continuous operation using the approved detensioning sequence.

37 For any particular group of members cast in the same bed, do not transfer the load to any
38 concrete until the test cylinder breaks indicate that the concrete in all these members has
39 reached the required strength as outlined in Subarticle 1078-4(B)(3). If these conditions are
40 not met, delay the transfer of the prestressing load to the concrete until tests of additional
41 cylinders show that the required strength is reached.

42 When curing at elevated temperatures, begin the procedures for transferring prestressing load
43 immediately after curing is discontinued and the forms are released, and while the concrete is
44 still hot to prevent cooling shrinkage and cracking. If so directed by the Engineer, cover
45 members or otherwise protect so as to cool the concrete slowly after release to prevent
46 thermal shock and the evaporation of moisture in the members.

Section 1078

1 Transfer load to not cause cracks in members. Transfer load by gradual release of the strands
2 as a group, by gradual release of part of the group, or by burning the fully tensioned strands at
3 the ends of the members. If intending to release the strands by a method other than gradual
4 release of the entire group, submit 6 copies of the proposed method and pattern of release, if
5 not so shown in the plans, for approval. Rigidly follow the approved method and pattern of
6 release. When the fully tensioned strands are burned, burn each strand or group of strands
7 simultaneously at each end of the bed in its indicated order in the pattern and at each end of
8 each member before proceeding to the strands in the next group in the pattern at any point.
9 Because of the critical nature of the bond development length in prestressed concrete panel
10 construction, if transferring of stress by burning the fully tensioned strands at the ends of the
11 member, burn each strand first at the ends of the bed and then at each end of each member
12 before proceeding to the next strand in the burning pattern.

13 When detensioning all girders, box beams, cored slabs, piles, and panels do not burn strands
14 quickly but heat with a low oxygen flame played along the strand for at least 5" until the
15 metal gradually loses its strength. Apply heat at such a rate that failure of the first wire in
16 each strand does not occur until at least 5 seconds after heat is first applied. When
17 detensioning other members, follow the above procedure unless an alternate procedure is
18 approved. Detensioning by arc welder is not allowed.

19 Incorporate the following in the method for single strand detensioning of members having
20 draped strands:

21 (A) Release the pair of straight strands located in the uppermost position in the lower flange
22 first.

23 (B) Then release the tension in the draped strands at the ends and uplift points in accordance
24 with an approved pattern.

25 (C) Disengage all hold-down devices for draped strands and release the hold-downs.

26 (D) Then release the pair of straight strands located in the upper flange.

27 (E) Release the remaining straight strands of the pattern in accordance with an approved
28 sequence.

29 (F) Release all strands in a manner meeting the Engineer's approval that will cause
30 a minimum shock and lateral eccentricity of loading.

31 Failure to follow the above procedures for transfer of load is ground for rejection of the
32 members involved.

33 **1078-12 VERTICAL CRACKS IN PRESTRESSED CONCRETE GIRDERS BEFORE** 34 **DETENSIONING**

35 This section addresses prestressed concrete members that have vertical casting cracks before
36 strand detensioning. Certain types of these cracks have been determined by the Department to
37 render the girders unacceptable.

38 Unacceptable cracked members are those with 2 or more vertical cracks spaced at a distance
39 less than the member depth which extend into the bottom flange. Such members are not
40 serviceable and will be rejected. Members with 2 or more vertical cracks spaced at a distance
41 less than the member depth but do not extend into the bottom flange are subject to
42 an engineering assessment. Such members may not be serviceable and may be rejected.

43 Members with one or more vertical cracks that extend into the bottom flange and are spaced
44 at a distance greater than the member depth are subject to an engineering assessment to
45 determine their acceptability. If this engineering assessment is required, submit, at no
46 additional cost to the Department, a proposal for repairing the member and a structural
47 evaluation of the member prepared by an engineer licensed by the State of North Carolina.

1 In the structural evaluation, consider the stresses under full service loads had the member not
 2 cracked and the effects of localized loss of prestress at the crack as determined by methods
 3 acceptable to the Department.

4 All members, except those defined as unacceptable, which exhibit vertical cracks before
 5 detensioning, shall receive a 7 day water cure as directed by the Engineer. The water cure
 6 shall begin within 4 hours after detensioning the prestressing strands and shall be at least 3 ft
 7 beyond the region exhibiting vertical cracks.

8 The Department has the final determination regarding acceptability of any members in
 9 question.

10 **1078-13 PRESTRESSED CONCRETE GIRDER WEB SPLITTING**

11 After detensioning of certain girders with draped strands, cracks occasionally occur in the
 12 webs at the ends of the girders. If such cracks occur, employ a method to remedy this
 13 condition on all subsequent girders of the same type and strand pattern. If debonding of
 14 strands is used, satisfy the following criteria:

15 (A) Do not debond the 2 straight strands in the top of the girder. Debond 1/2 of the straight
 16 strands, as nearly as possible, in the bottom flange. As nearly as possible, debond 1/4 of
 17 the straight strands in the bottom of girder 4 ft from each end of the girder and debond
 18 1/4 of the straight strands 2 ft from each end of the girder.

19 (B) Use a debonding pattern that is symmetrical about the vertical axis of the girder.

20 (C) Debond strands so the center of gravity of the strands in the bottom of the girder remain
 21 within 1" of their original location at the end of the girder.

22 (D) Debond strands by encasing the strand in a conduit meeting the approval of the Engineer.
 23 Conduit may be rigid one-piece or rigid 2-piece split sheathing. Do not use flexible
 24 conduit or sheathing.

25 No separate payment is made for debonding strands as payment is included in the contract
 26 unit price bid for prestressed concrete girders.

27 **1078-14 HANDLING, TRANSPORTING AND STORING**

28 Members damaged while being handled or transported are rejected or require repair in
 29 a manner approved by the Engineer. All members are allowed to be handled immediately
 30 after transfer of load from the anchorages to the members is complete.

31 Store all prestressed members on solid, unyielding, storage blocks in a manner to prevent
 32 torsion or objectionable bending. In handling prestressed concrete girders 54" or less in
 33 height, including cored slabs and box beams, maintain them in an upright position at all times
 34 and pick them up within 5 ft of the points of bearing and transport and store supported only
 35 within 3 ft of points of bearing. In handling prestressed concrete girders greater than 54" in
 36 height, maintain them in an upright position at all times and submit for approval the proposed
 37 method of lifting, transporting, and storing the girders. When requested, provide calculations
 38 to confirm girders are not overstressed by such operations.

39 Prestressed concrete panels are weak in the direction perpendicular to the prestressing strands,
 40 therefore, they are subject to breakage during handling, storing or transporting. Provide
 41 adequate blocking during all of these construction phases.

42 In handling, transporting, and storing prestressed members, use the number and location of
 43 supports in accordance with the plan requirements for the sizes, lengths and types of members
 44 involved, or as approved.

45 When handling the prestressed concrete members, a temporary stress of $5\sqrt{f_{ci}}$ is permitted,
 46 where f_{ci} is the strength of concrete at release, in pounds per square inch.

Section 1078

- 1 Do not transport members away from the casting yard until the concrete reaches the minimum
2 required 28 day compressive strength and a period of at least 5 days elapses since casting,
3 unless otherwise permitted.
- 4 Do not transfer any member from the plant to the job site before approval of that member by
5 the plant inspector. This approval is stamped on the member by the plant inspector.
- 6 **1078-15 FINAL FINISH**
- 7 Finish prestressed concrete members that are intended for composite action with subsequently
8 placed concrete or asphalt with a roughened surface for bonding. Make sure that no laitance
9 remains on the surfaces to be bonded.
- 10 Rough float the tops of girders. Broom finish the top surface of the cored slab and box beam
11 sections receiving an asphalt overlay. Rake the top surface of cored slab and box beam
12 sections receiving a concrete overlay to a depth of 3/8". No surface finish is required for sides
13 and bottom of the slab and beam sections except the exposed side of the exterior unit as noted
14 below. Provide a resulting surface finish essentially the same color and surface finish as the
15 surrounding concrete.
- 16 Provide a 3/4" chamfer along the bottom edges on ends and sides of all box beam and cored
17 slab sections, top outside edges of exterior sections and acute corners of sections. Round the
18 top edges on ends of all sections with a 1/4" finishing tool. Provide square corners along top
19 edges on all sections along shear keys. Do not chamfer vertical edges at ends of sections.
- 20 Fill all voids in the diagonal face of the bottom flange of prestressed concrete girders and the
21 outside face of exterior cored slabs and box beams with a sand-cement or other approved
22 grout. Fill all voids in piles greater than 1/2" in diameter or depth as above. Provide
23 a resulting surface finish essentially the same color and surface finish as the surrounding
24 concrete. Repair voids greater than 1/4" in diameter or depth in other faces of these and other
25 members except piles in a like manner. Where an excessive number of smaller voids exist in
26 any member, the Engineer requires a similar repair.
- 27 Repair honeycomb, excessively large fins, and other projections as directed. Submit, at no
28 additional cost to the Department, a proposal for repairing members with honeycomb, cracks
29 or spalls. Do not repair members containing honeycomb, cracks, or spalls until a repair
30 procedure is approved and the member is inspected by the Engineer. Any appreciable
31 impairment of structural adequacy that cannot be repaired to the satisfaction of the Engineer is
32 cause for rejection.
- 33 Clean and fill holes caused by strand hold downs upon removal from the casting bed. Use
34 patches of materials approved by the Engineer that develop strength at least equal to the
35 minimum 28 day strength requirement for the concrete before approval of the member.
36 Ensure that members are clean and surfaces have a uniform appearance.
- 37 Give the top surface of prestressed concrete panels a raked finish or other approved finish to
38 provide an adequate bond with the cast-in-place concrete. As soon as the condition of the
39 concrete permits, rake the top surface of the concrete making depressions of approximately
40 1/4". Take care when raking not to catch and pull the coarse aggregate.
- 41 Clean reinforcing bars exposed on the tops of girders and exterior cored slabs or box beams of
42 mortar build up and excessive rust.
- 43 Apply epoxy protective coating to the ends of prestressed members as noted in the plans.

1 **1078-16 ALIGNMENT AND DIMENSIONAL TOLERANCES**

2 **(A) Piles**

3 Manufacture piles within the tolerances indicated in Table 1078-3 and Figure 1078-1.

4 **(B) Cored Slabs**

5 To ensure a good, neat field fit, assemble cored slab spans in the yard and have pieces
6 matchmarked. Ensure that pieces fit together neatly and in a workmanlike manner.

7 Manufacture cored slabs within the tolerances indicated in Table 1078-4 and
8 Figure 1078-2.

9 **(C) Girders**

10 Manufacture girders within the tolerances indicated in Table 1078-5 and Figure 1078-3.

11 **(D) Prestressed Concrete Panels**

12 Manufacture prestressed concrete panels within the tolerances indicated in Table 1078-6.

13 **(E) Box Beams**

14 To ensure a good, neat field fit, assemble box beam spans in the yard and have pieces
15 match-marked. Ensure that pieces fit together neatly and in a competent manner.

16 Manufacture box beams within the tolerances indicated in Table 1078-7 and
17 Figure 1078-4.

Section 1078

1 1078-17 IDENTIFICATION OF MEMBERS

- 2 Permanently identify each prestressed member by number and date of manufacture, and paint
- 3 this information, or otherwise mark as approved by the Engineer, on at least one end of the
- 4 member as soon as practical after manufacture. In the case of girders or cored slabs, paint
- 5 other identification as to station, span and position within the span on at least one end of the
- 6 member.

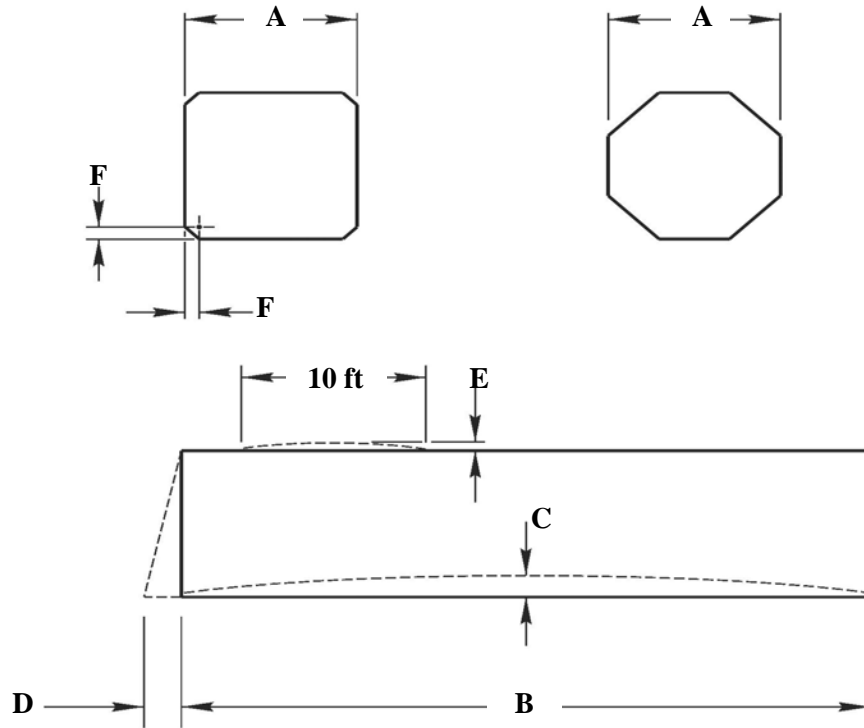

7 Figure 1078-1. Prestressed Piles. Dimensions shown are in Table 1078-3.

TABLE 1078-3
TOLERANCES FOR PRESTRESSED PILES
 (Refer to Figure 1078-1)

Dimension	Tolerance
Width (A)	-1/4" to +3/8"
Length (B)	± 1 1/2"
Horizontal alignment Deviation from a straight line parallel to the centerline of pile (C)	1/8" per 10 ft
Squareness of ends (D)	1/8" per 12" of width, 3/16" max.
Local smoothness (E)	1/4" in 10 ft
Position of strands (F)	1/4"
Position of mild reinforcing steel, including spiral pitch	1/2"

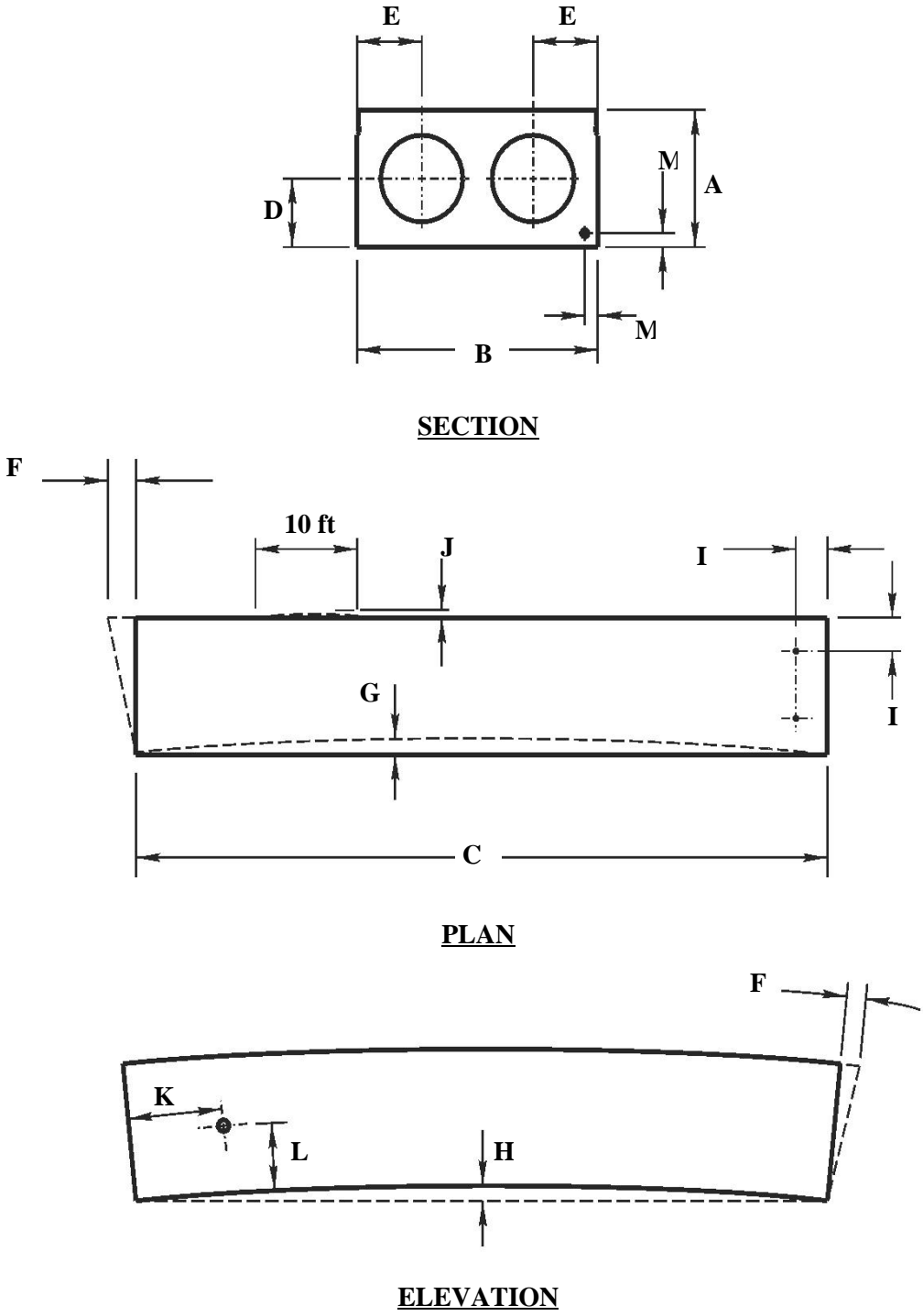

1 Figure 1078-2. Prestressed cored slabs. Dimensions shown are in Table 1078-4.

TABLE 1078-4 TOLERANCES FOR PRESTRESSED CORED SLABS (Refer to Figure 1078-2)	
Dimension	Tolerance
Depth (A)	+3/8" to -1/8"
Width (B)	± 1/4"
Length (C)	± 1/8" per 10 ft
Position of voids - Vertical (D)	± 3/8"
Position of voids - Horizontal (E)	± 3/8"
Position of void Ends – Longitudinal	+1", -3"
Square ends - Deviation from square (horizontal) or vertical) or designated skew (F)	±1/4"
Horizontal alignment - Deviation from a straight line parallel to the centerline of member (G)	0-30 ft long: 1/4" 30-50 ft long: 3/8" 50+ ft long: 1/2"
Camber - Differential between adjacent units (H)	1/4" per 10 ft, 3/4" max.
Camber - Differential between high and low members of same span (H)	3/4" max.
Position of dowel holes - Deviation from plan position (I)	1/4"
Width - Any one span	Plan width +1/8" per joint
Width - Differential of adjacent spans in the same structure	1/2"
Bearing area - Deviation from plane surface	1/16"
Local smoothness (J)	1/4" in 10 ft
Position of holes for transverse strands	Horizontal (K): ±1/2" Vertical (L): ±3/8"
Position of strands (M)	± 1/4"

1 **1078-18 QUALITY CONTROL**

- 2 Maintain a daily quality control record form approved by the Engineer including pertinent
 3 information concerning tensioning, concrete quality and placement, curing and detensioning.
 4 Have this form signed and dated by a certified concrete technician. Furnish a copy of the
 5 completed or up-to-date form to the Materials and Tests Unit upon request and before any
 6 members are approved. A sample form, indicating the minimum required information, is
 7 available from the Materials and Tests Unit.

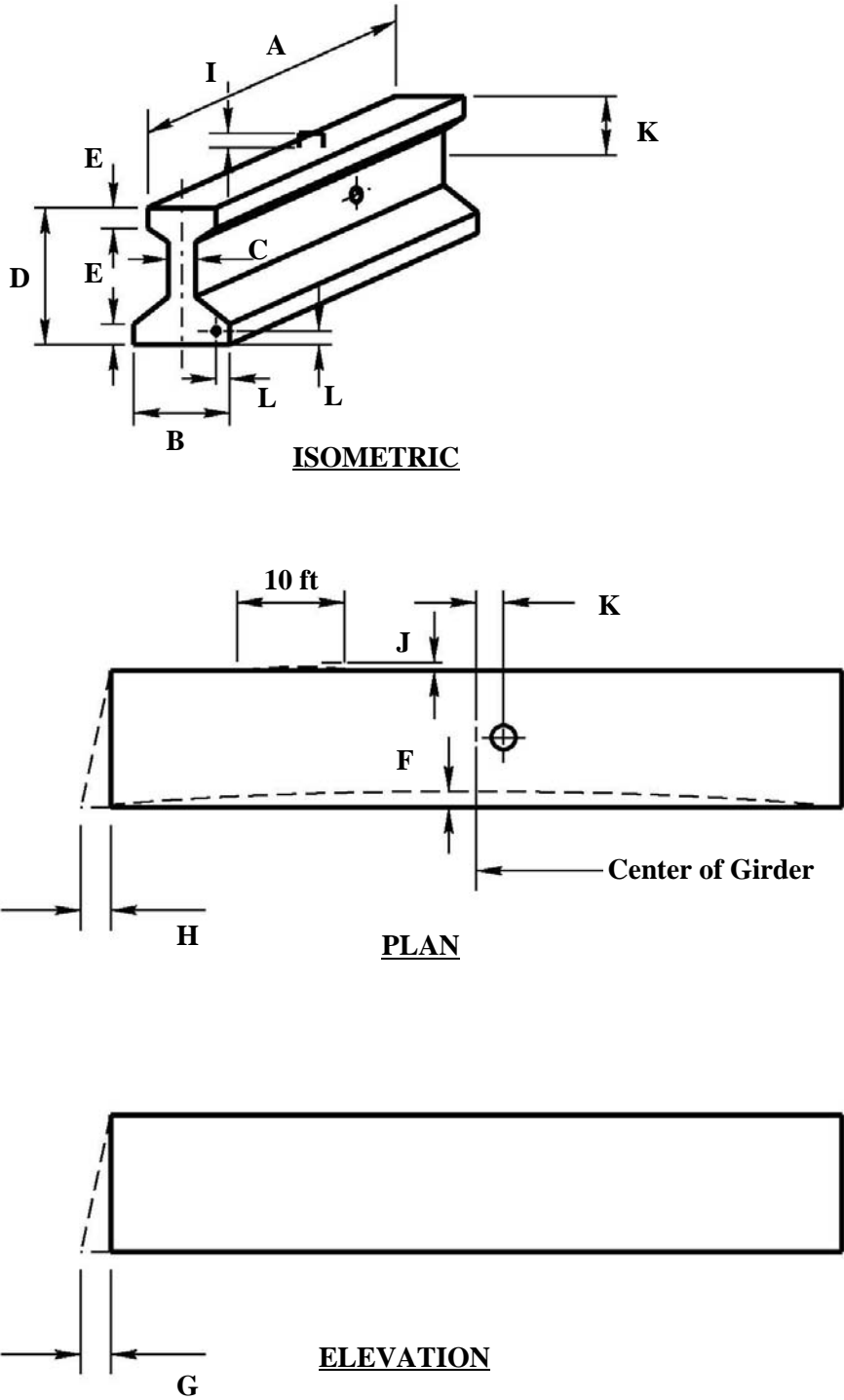

1 **Figure 1078-3. Prestressed Girders.** Dimensions shown are in Table 1078-5.

TABLE 1078-5 TOLERANCES FOR PRESTRESSED GIRDERS (Refer to Figure 1078-3)	
Dimension	Tolerance
Length (A) Girders 80 ft. or shorter	$\pm 1/8$ " per 10 ft
Length (A) Girders longer than 80 ft.	$\pm 1/8$ " per 10 ft Not to exceed 1 1/2"
Width - Flanges(B)	+3/8" to -1/8"
Width - Web (C)	+3/8" to -1/8"
Depth - Overall (D)	+1/2" to -1/4"
Depth - Flanges (E)	$\pm 1/4$ "
Horizontal alignment (top or bottom flange) Deviation from a straight line parallel to the centerline of beam (F)	$\pm 1/8$ " per 10 ft Not to exceed 1"
Bearing plate Deviation from plane surface	1/16"
Girder ends Deviation from square or designated skew (G and H)	Vertical (G): $\pm 1/8$ " per 12" of girder height Horizontal (H): $\pm 1/2$ "
Position of stirrups - Projection above top of girder (I)	$\pm 1/2$ "
Position of stirrups – Placement along girder length	± 1 "
Local smoothness of any surface (J)	1/4" in 10 ft
Position of holes for diaphragm bolts (K)	$\pm 1/4$ "
Position of strands (L)	$\pm 1/4$ "

- 1 Dimensions followed by an alphabetical suffix are shown in Figure 1078-3. The length (A) is
 2 measured along the top of the top flange. The tolerances at girder ends (G and H) are
 3 increased to 1" if the girder end is to be encased in a full depth concrete diaphragm.

4

TABLE 1078-6 TOLERANCES FOR PRESTRESSED CONCRETE PANELS	
Dimension	Tolerance
Length (Transverse direction to girders)	-1/4" to +1/2"
Width (Longitudinal direction to girders)	-1/8" to +1/4"
Depth	0 to +3/8"
Position of Strand Horizontal Dimension	$\pm 1/8$ "
Vertical Dimension	$\pm 1/2$ "

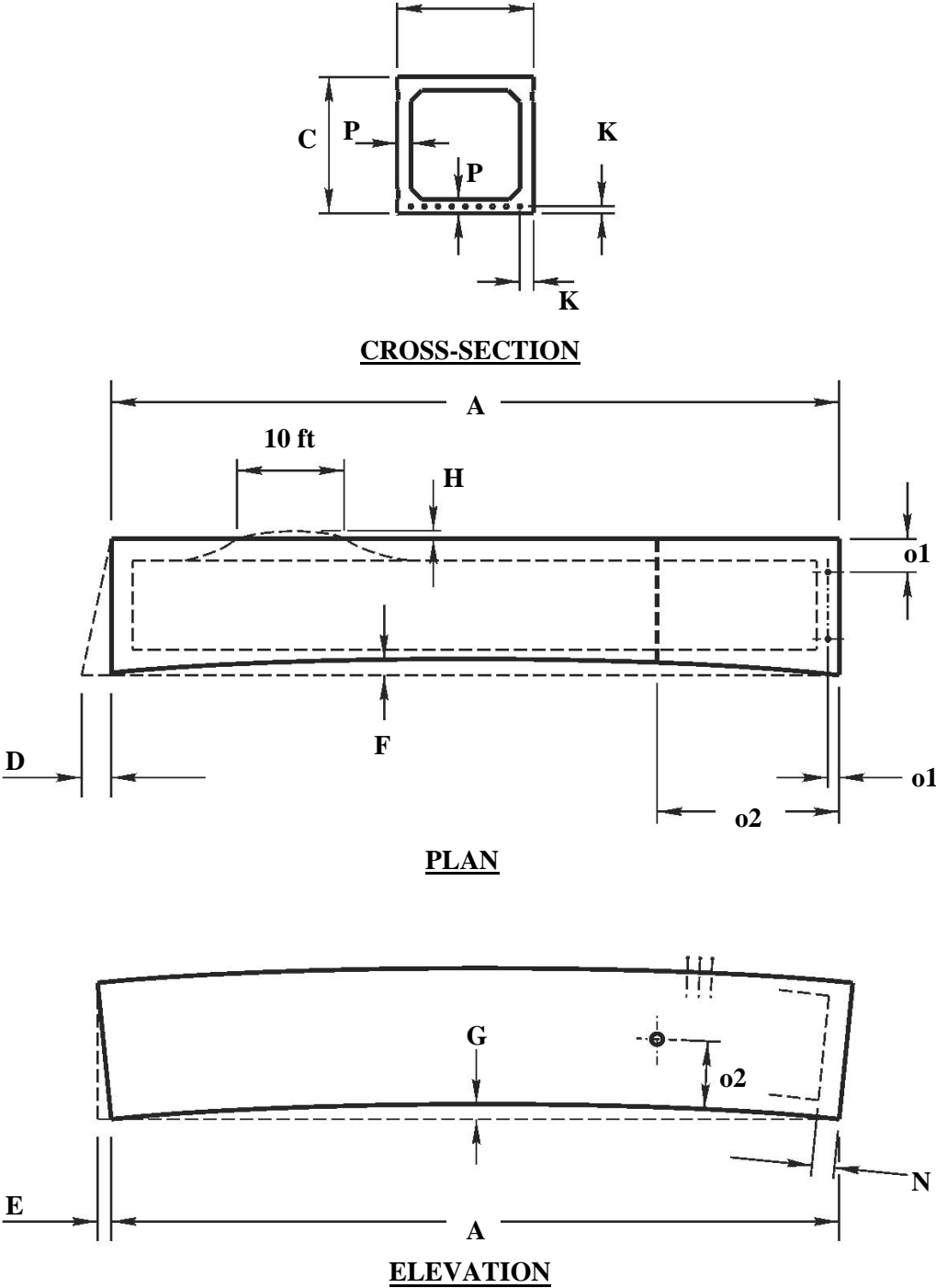

1 **Figure 1078-4. Prestressed Box Beams.** Dimensions shown are in Table 1078-7.

TABLE 1078-7 TOLERANCES FOR BOX BEAMS (Refer to Figure 1078-4)	
Dimension	Tolerance
Length (A)	+ 1"
Width (overall) (B)	+ 1/4"
Depth (overall) (C)	+ 1/4"
Variation from specified plan end squareness or skew (D)	+ 1/8" per 12" width, + 1/2" max
Variation from specified elevation end squareness or skew (E)	+ 1/8" per 12", + 1/2" max
Sweep, for member length (F) up to 40 ft	+ 1/4"
Sweep, for member length (F) 40 to 60 ft	+ 3/8"
Sweep, for member length (F) greater than 60 ft	+ 1/2"
Differential camber between adjacent members (G):	1/4" per 10 ft., 3/4" max
Local smoothness of any surface (H)	1/4" in 10 ft
Position of strands (K)	+ 1/4"
Longitudinal Position of blackout (N)	+ 1"
Position of dowel holes (o1)	+ 1/4"
Position of sleeves cast in beams, in both horizontal and vertical plane (o2)	+ 1/2"
Position of void (P)	+ 3/8"
Bearing area – deviation from plane surface	+ 1/16"
Width - Any one span	Plan width + 1/8" per joint
Width – Differential of adjacent spans in the same structure	1/2"

1

SECTION 1079

2

BEARINGS AND BEARING MATERIALS

3

1079-1 PREFORMED BEARING PADS

4 Provide preformed bearing pads composed of multiple layers of 8 oz/sy cotton duck
5 impregnated and bound with high quality natural rubber, or equally suitable materials
6 approved by the Engineer, that are compressed into pads of uniform thickness. Ensure that
7 the thickness of the preformed bearing pads is 3/16" with a tolerance of $\pm 1/16"$. Use cotton
8 duck that meets Military Specification MIL-C882-D for 8 oz/sy cotton army duck or
9 equivalent. Provide enough pads as to produce the required thickness after compressing and
10 vulcanizing. Ensure that the finished pads withstand compressive loads perpendicular to the
11 plane of the laminations of not less than 10,000 psi without detrimental extrusion or reduction
12 in thickness.

13 Furnish a Type 3 certification in accordance with Article 106-3 certifying that the preformed
14 bearing pads meet this Specification.

15

1079-2 ELASTOMERIC BEARINGS

16

(A) General

17

Provide elastomeric bearings that meet the requirements of AASHTO M251, except as
18 specified herein.

19

Manufacturers shall be pre-qualified by the Department and shall submit working
20 drawings for approval. Refer to Subarticles 1079-2(D) and 1079-2(E). Furnish a Type 3
21 certification in accordance with Article 106-3 certifying that elastomeric bearings satisfy
22 this Specification and all design criteria. Include the lot number, description and test
23 results in the certification.