

- 
1. The map below shows a meandering river.  $A-A'$  is the location of a cross section. The arrows show the direction of the river flow.

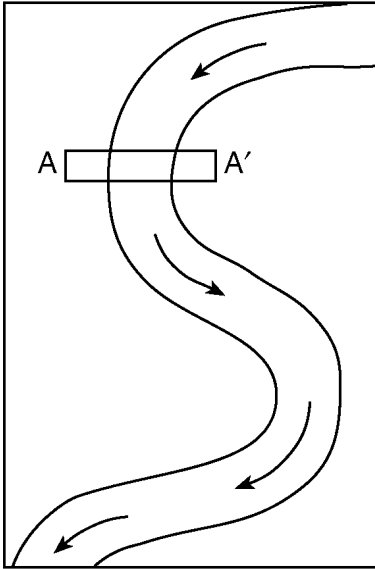

Which cross section best represents the shape of the river bottom at  $A-A'$ ?



2. What change will a pebble usually undergo when it is transported a great distance by streams?
- A) It will become jagged and its mass will decrease.  
B) It will become jagged and its volume will increase.  
C) It will become rounded and its mass will increase.  
**D) It will become rounded and its volume will decrease.**
-

- 
3. The block diagram below represents an igneous dome that uplifted overlying rock layers, which were then weathered and eroded.

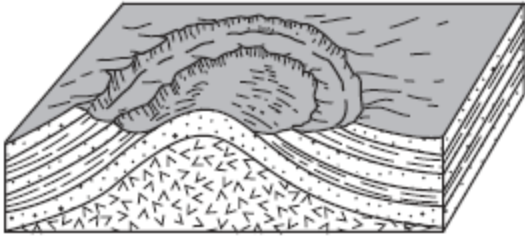

Which stream drainage pattern is most likely found on the surface of the area represented by the block diagram?

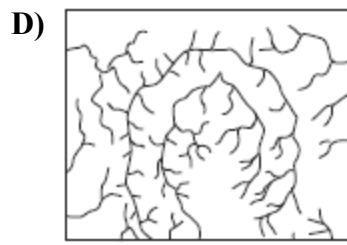
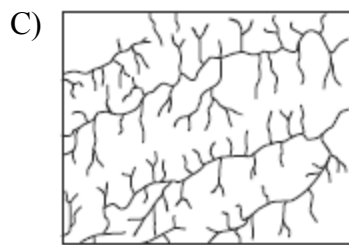
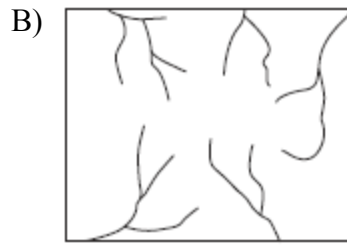
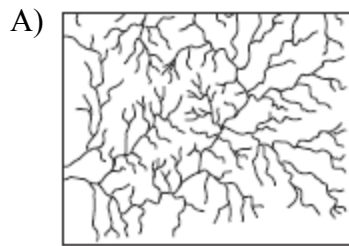

Base your answers to questions 4 through 6 on the information and diagrams below.

A mixture of colloids, clay, silt, sand, pebbles, and cobbles is put into stream I at point *A*. The water velocity at point *A* is 400 centimeters per second. A similar mixture of particles is put into stream II at point *A*. The water velocity in stream II at point *A* is 80 centimeters per second.

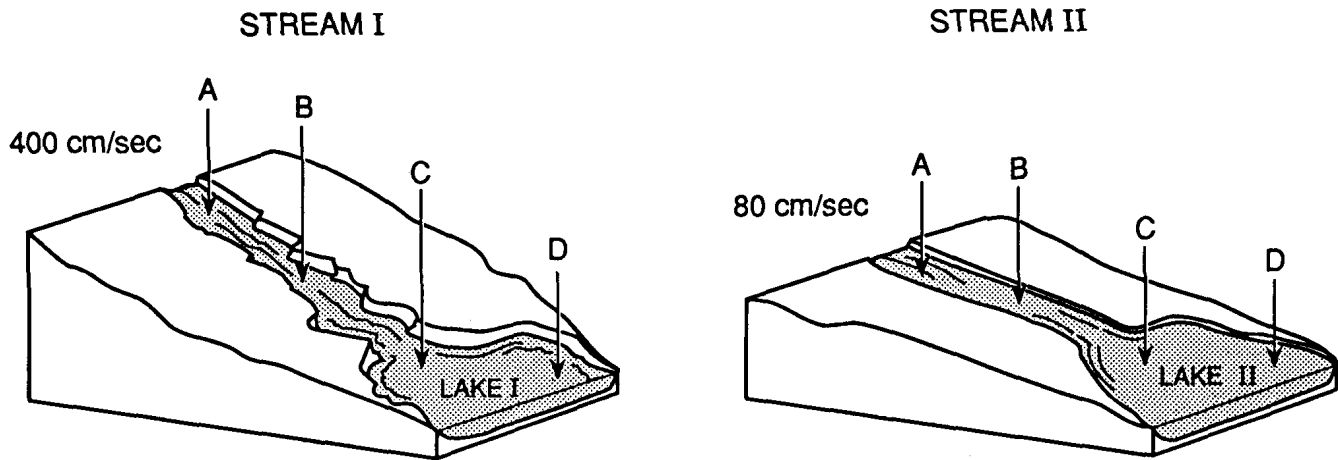

4. Which statement best describes what happens when the particles are placed in the streams?

- A) **Stream I will move all particles that are added at point *A*.**
- B) Stream II will move all particles that are added at point *A*.
- C) Stream I cannot move sand.
- D) Stream II cannot move sand.

5. Which statement is the most accurate description of conditions in both streams?

- A) The greatest deposition occurs at point *B*.
- B) **Particles are carried in suspension and by bouncing along the bottom.**
- C) The particles will have a greater velocity than the water in the stream.
- D) The velocity of the stream is the same at point *B* as at point *C*.

6. If a sudden rainstorm occurs at both streams above point *A*, the erosion rate will

- A) increase for stream I, but not for stream II
- B) increase for stream II, but not for stream I
- C) **increase for both streams**
- D) not change for either stream

7. Which quartz sample has probably undergone abrasion in a stream for the longest period of time?

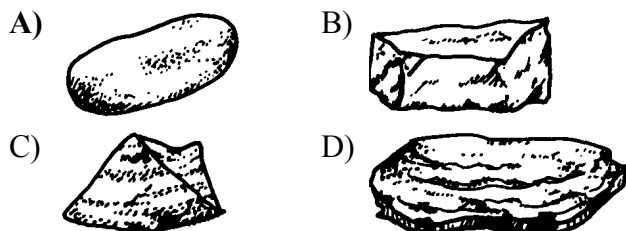

8. A sediment particle transported by a stream over a long period of time will most likely show

- A) **a decrease in mass and number of angular edges**
- B) a decrease in density and size
- C) an increase in weight and hardness
- D) an increase in volume and number of cleavage planes

- 
9. The diagram below is a map view of a stream flowing through an area of loose sediments. Arrows show the location of the strongest current.

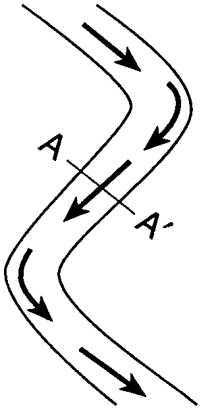

Which stream profile best represents the cross section from *A* to *A'* ?

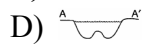
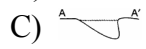
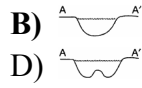
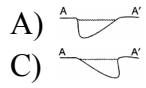

Base your answers to questions 10 through 13 on the diagram below, which represents the landscape features associated with a meandering river. Letters *W*, *X*, *Y*, and *Z* represent locations on the floodplain.

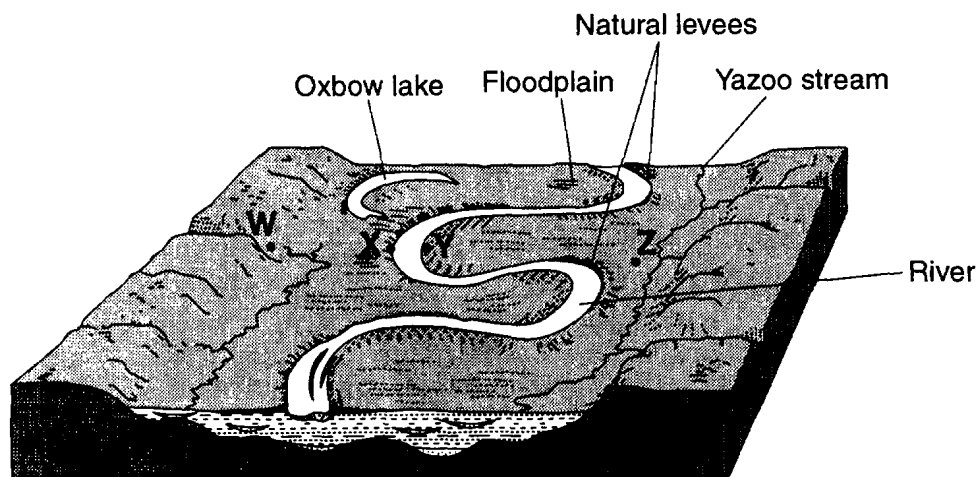

10. The choices below represent stages in the formation of a meandering river. Which sequence *best* represents the usual changes over time?

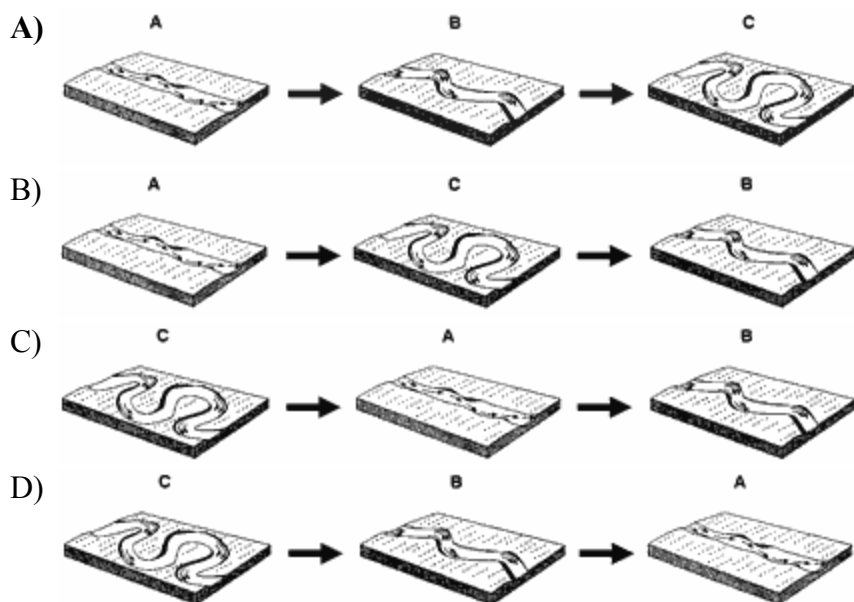

11. Which change would most likely increase the velocity of the river?

- A) a decrease in the slope of the river
- B) a decrease in the temperature of the river
- C) **an increase in the river's discharge**
- D) an increase in the width of the river

12. During transport by this river, a sediment particle will most likely become

- A) **more rounded**
- B) more dense
- C) heavier
- D) larger

13. At which location is erosion greatest?

- A) *W*
- B) *X*
- C) *Y*
- D) *Z*

14. The diagram below shows the cross section of a stream channel and the height of the stream surface on various dates of the year.

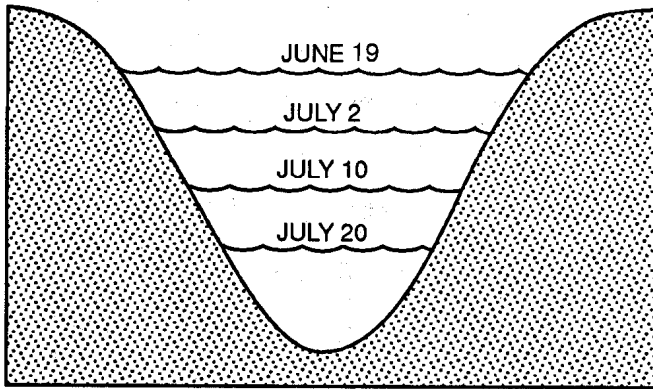

The stream's velocity from June 19 to July 20 at this section of the stream most likely

- A) decreased, only  
 B) decreased, then increased  
 C) increased, only  
 D) remained constant
15. The map below shows a meandering stream as it enters a lake. The arrow shows the direction of stream flow. Points *A* through *D* represent locations on the surface of the stream.

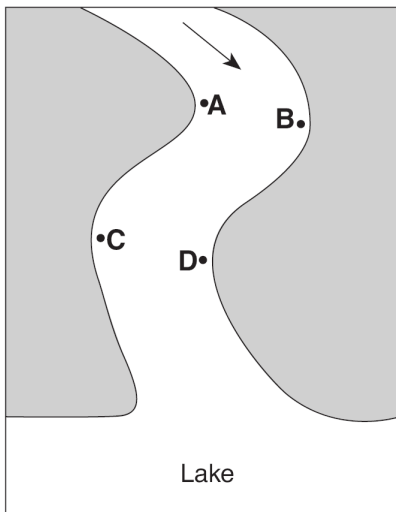

The greatest stream velocities are found closest to points

- A) *A* and *B*                      B) *B* and *C*  
 C) *C* and *D*                      D) *D* and *A*

Base your answers to questions 16 through 18 on the diagram below, which shows several different landscape features. Points *X* and *Y* indicate locations on the streambank.

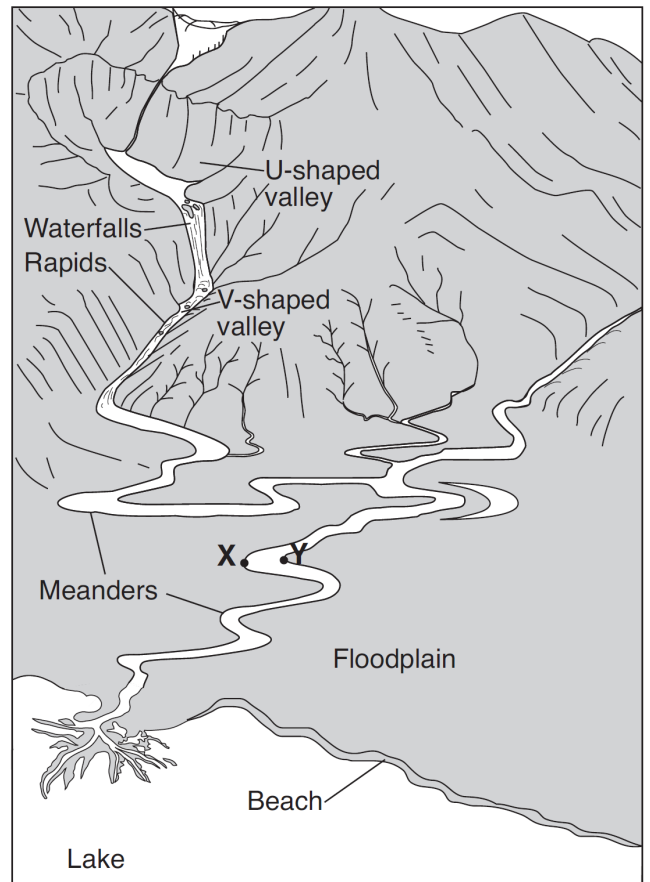

16. Explain why the stream meanders on the floodplain, but *not* in the mountains.
17. Identify which point, *X* or *Y*, has more stream erosion and explain why the amounts of erosion are different.
18. Explain why the upper valley in the mountains is U-shaped and the lower valley is V-shaped.

19. The map below shows the bend of a large meandering stream. The arrows show the direction of stream flow, Letters *A*, *B*, and *C* are positions on the streambed where erosion and deposition data were collected.

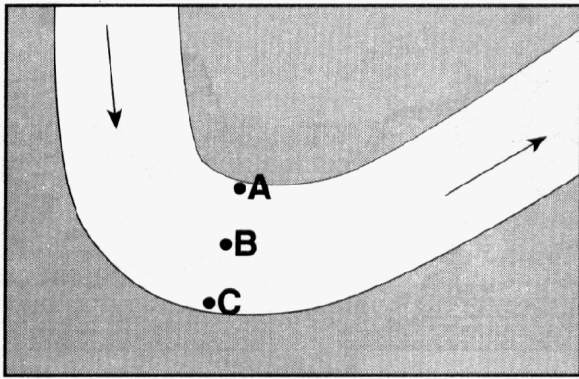

Which table best represents the locations where erosion and deposition are dominant and where an equilibrium exists between the two processes? [A check mark represents the dominant process for each lettered location.]

A) 

	Erosion	Equilibrium	Deposition
A		✓	
B			✓
C	✓		

B) 

	Erosion	Equilibrium	Deposition
A			✓
B	✓		
C		✓	

C) 

	Erosion	Equilibrium	Deposition
A	✓		
B		✓	
C			✓

D) 

	Erosion	Equilibrium	Deposition
A			✓
B		✓	
C	✓		

20. The map below represents a meandering stream flowing into a lake. A student measured water depths in the stream at three locations: *A-A'*, *B-B'*, and *C-C'*.

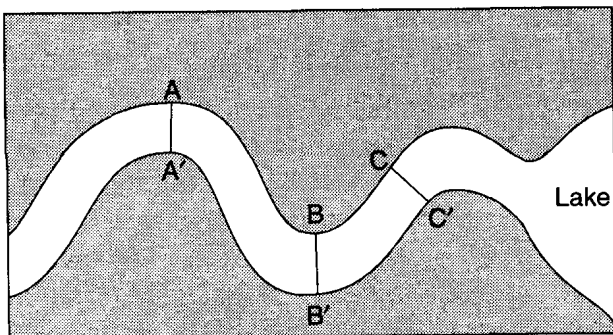

Which set of cross sections best represents the stream bed at the three locations?

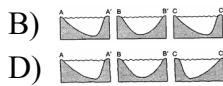
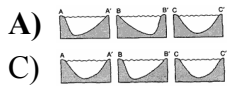

21. The map below represents a large stream meander (bend). The arrows show the direction of stream flow. Stream velocity was measured at surface locations *A*, *B*, and *C*.

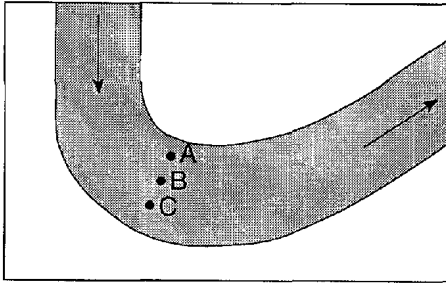

Which graph best represents the relative velocities of the stream at locations *A*, *B*, and *C*?



22. The diagram below shows a post set in the streambed of a river. The river levels between May 5 and May 10 were recorded on the post by an observer at noon each day.

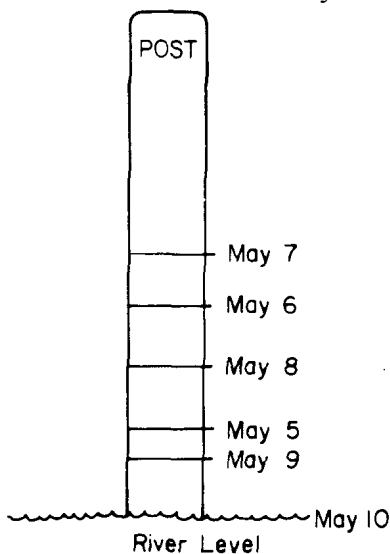

Which graph shows the probable stream current velocity that occurred during this same time period?



23. The model shown below illustrates stream erosion between locations *A* and *B* in the stream.

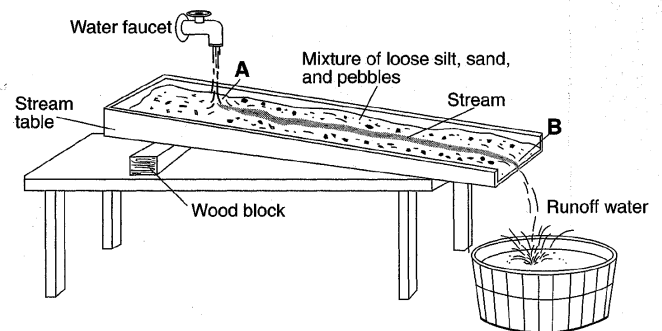

Placing a second block under location *A* will cause the stream's velocity to

- A) decrease and the rate of erosion to decrease  
 B) decrease and the rate of erosion to increase  
 C) increase and the rate of erosion to decrease  
**D) increase and the rate of erosion to increase**
24. What change will a pebble usually undergo when it is transported a great distance by streams?
- A) It will become jagged and its mass will decrease.  
 B) It will become jagged and its volume will increase.  
 C) It will become rounded and its mass will increase.  
**D) It will become rounded and its volume will decrease.**



---

25. Based on the diagrams of rock fragments below, which shows the *least* evidence of erosion?

A)



B)



C)



D)



26. The block diagram below represents a stream flowing from a mountain region.

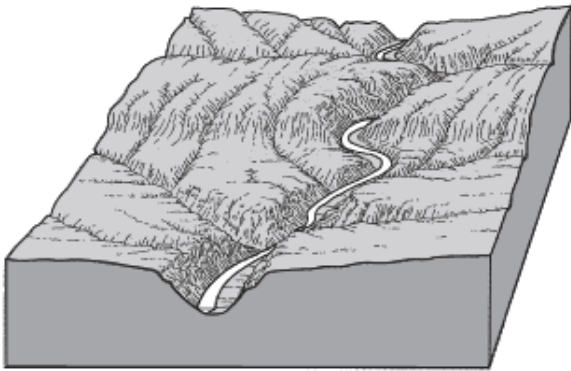

A brief, heavy rainstorm occurs in the mountains. How will the volume of water and the rate of erosion in the stream change shortly after the rainstorm?

A) The volume of water will decrease and the rate of erosion will increase.

B) The volume of water will increase and the rate of erosion will decrease.

C) Both the volume of water and the rate of erosion will decrease.

**D) Both the volume of water and the rate of erosion will increase.**

27. An increase in the velocity of a stream is most likely due to

A) **an increase in stream discharge**

B) an increase in the width of the riverbed

C) a decrease in the slope of the stream channel

D) a decrease in the amount of material held in suspension

---

28. Base your answer to the following question on the diagrams below. Diagrams *A*, *B*, and *C* represent three different river valleys.

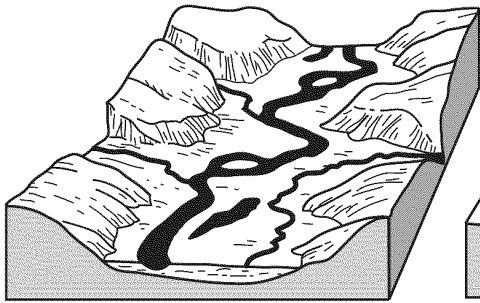

Diagram A

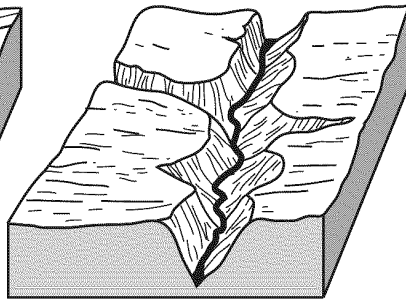

Diagram B

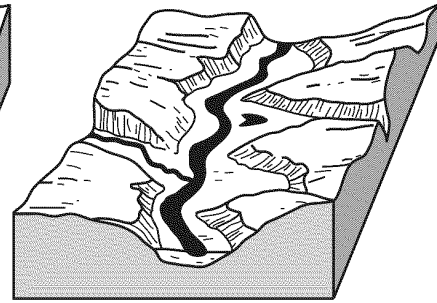

Diagram C

Most sediments found on the floodplain shown in diagram *A* are likely to be

- A) angular and weathered from underlying bedrock
- B) angular and weathered from bedrock upstream
- C) rounded and weathered from underlying bedrock
- D) rounded and weathered from bedrock upstream**

29. Stream *A* has a steeper slope than stream *B*. However, the average water velocity of stream *B* is greater than that of stream *A*. Which is the most reasonable explanation for this?

- A) Stream *B* has more friction to overcome along its banks.
- B) Stream *B* has a higher average temperature.
- C) Stream *B* has a greater volume of water.**
- D) Stream *B* has a curved streambed.

30. The diagram below shows a glacial landscape feature forming over time from a melting block of ice.

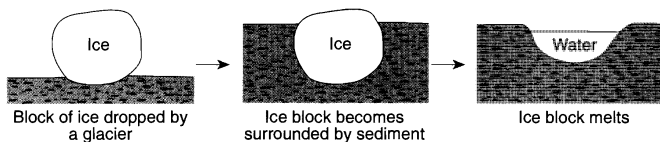

This glacial landscape feature is best identified as

- A) a kettle lake**                      B) an outwash plain
- C) a finger lake                      D) a moraine

31. The map below shows the area surrounding a meandering stream.

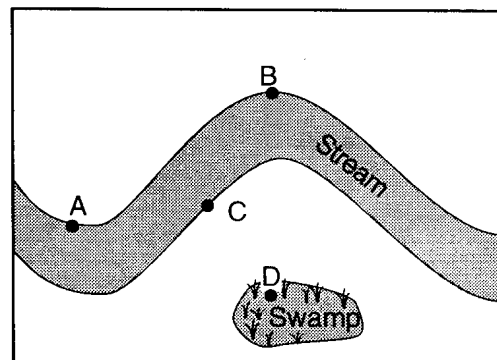

At which point is erosion greatest?

- A) *A*      **B) *B***      C) *C*      D) *D*

32. The diagram below shows a sedimentary rock sample.

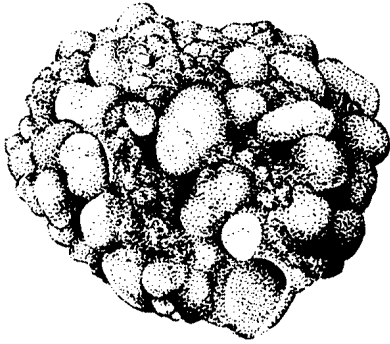

(Shown actual size)

Which agent of erosion was most likely responsible for shaping the particles forming this rock?

- A) mass movement    B) wind  
C) glacial ice        **D) running water**
33. As a result of glaciation, New York has
- A) few lakes  
B) many V-shaped valleys  
**C) many sand and gravel deposits**  
D) thick soils formed "in place" from underlying bedrock
34. The diagram below shows a stream flowing past points *X* and *Y*. If the velocity of the stream at point *X* is 100 centimeters per second, which statement best describes the sediments being transported past these points?

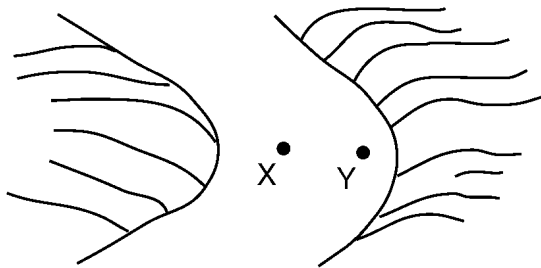

- A) At points *X* and *Y*, only clay is being transported.
- B) At points *X* and *Y*, only sand, silt, and clay are being transported.
- C) Some pebbles being transported at point *Y* are bigger than those being transported at point *X*.**
- D) Some pebbles and cobbles are being transported at points *X* and *Y*, but not sand, silt, or clay.

35. The diagram below represents a cross section of a stream. Points *A*, *B*, *C*, *D*, and *E* are locations within the stream channel.

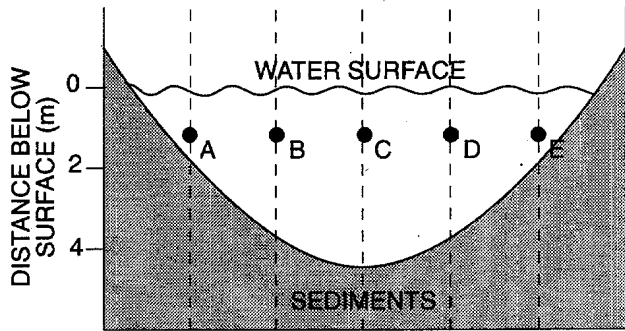

Which graph best represents stream velocity at locations *A* through *E*?



36. Why do most streams in the Northeast have a greater stream discharge in spring than in summer?

- A) Potential evapotranspiration is greater in spring than in summer.
- B) More transpiration occurs in spring than in summer.
- C) Most New York State water budgets have a deficit in spring.
- D) Melting snow increases runoff in spring.**

Base your answers to questions 37 and 38 on the diagram and data table below. The diagram shows the equipment used to determine the factors affecting the rate of erosion in a stream. The data table shows the time it took a 10-gram sample of quartz sand to move 100 centimeters down the rain gutter under various conditions.

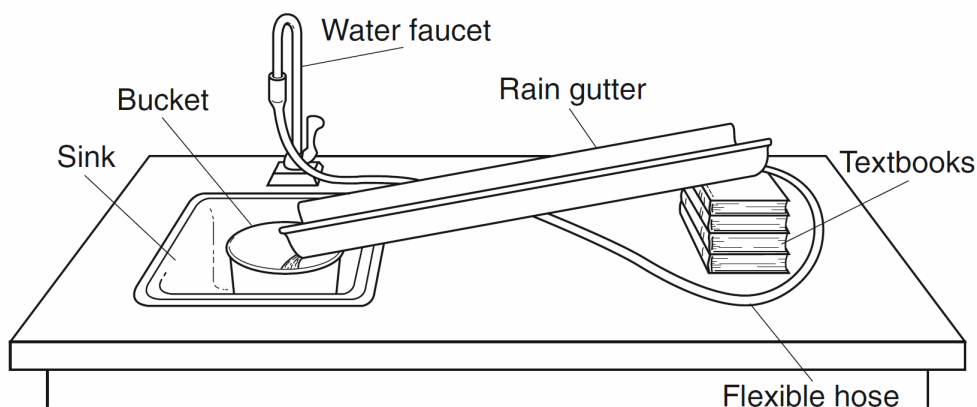

**Data Table**

Rain Gutter Slope	Water Velocity	Erosion Time (s)	
		Fine Sand	Coarse Sand
5°	slow	20	60
	fast	15	40
10°	slow	15	40
	fast	10	30
20°	slow	10	30
	fast	5	15

37. What is the relationship between the water velocity and the rate of erosion?
- A) If the water velocity decreases, the rate of erosion increases.
  - B) If the water velocity increases, the rate of erosion increases.**
  - C) If the water velocity remains constant, the rate of erosion decreases.
  - D) If the water velocity remains constant, the rate of erosion increases.
38. In this experiment, the water velocity could be increased by
- A) decreasing the slope of the rain gutter
  - B) increasing the amount of water from the faucet**
  - C) lowering the flexible hose
  - D) widening the rain gutter

39. Base your answer to the following question on the map and cross sections below. The map shows measured changes in the position of Niagara Falls since 1678. The cross sections show the two parts of Niagara Falls: Horseshoe Falls and American Falls. Letters *A* through *D* represent the same rock layers at both locations.

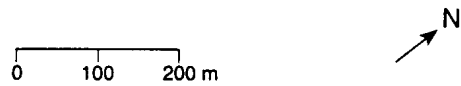
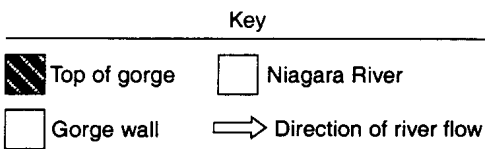
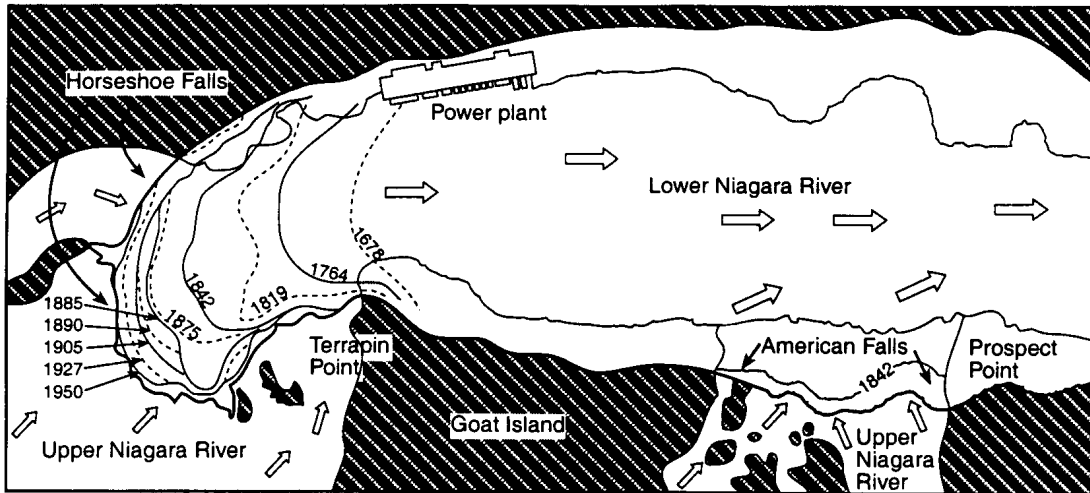

Horseshoe Falls

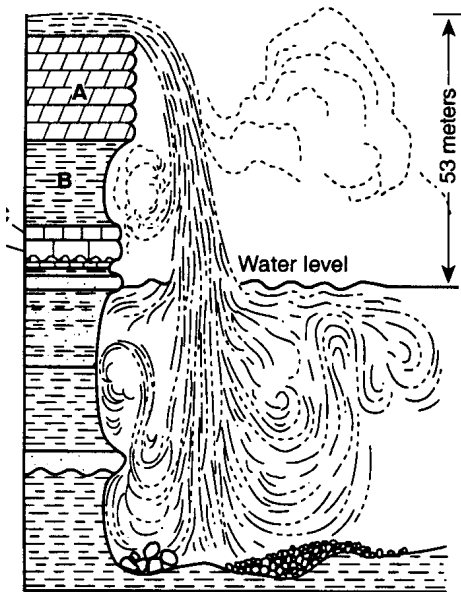

American Falls

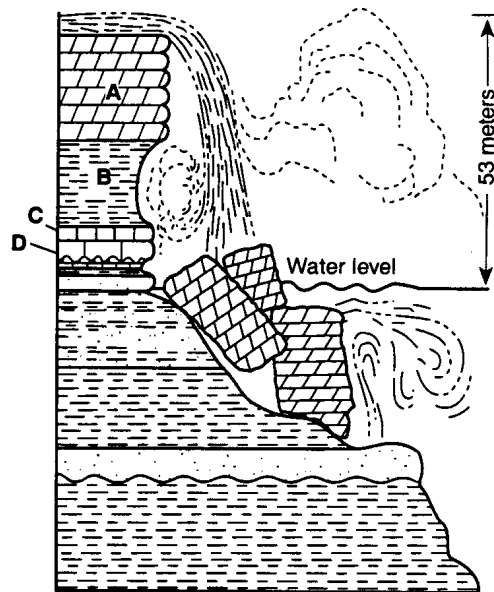

Which rock layer shows the most resistance to weathering and erosion at Horseshoe Falls?

- A) *A*      B) *B*      C) *C*      D) *D*

40. The diagram below shows a meandering stream flowing across nearly flat topography and over loose sediments.

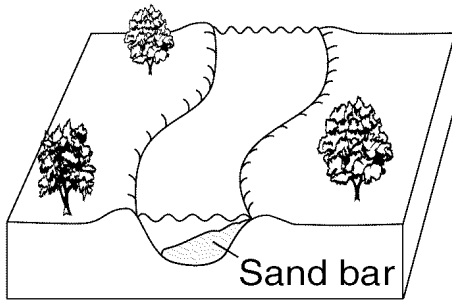

If arrow length represents stream velocity, which diagram best shows the relative stream velocities in this section of the stream?



41. A river's current carries sediments into the ocean.  
Which sediment size will most likely be deposited in deeper water farthest from the shore?

- A) pebble
- B) sand
- C) silt
- D) clay**

42. The cross section below represents a portion of a meandering stream. Points *X* and *Y* represent two positions on opposite sides of the stream.

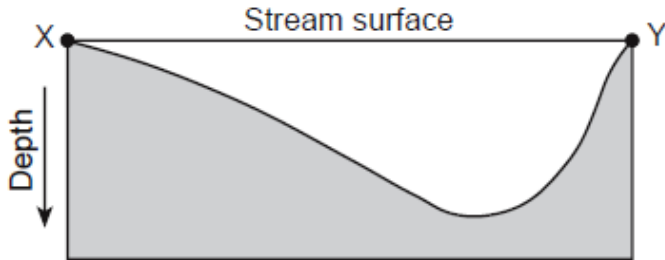

Based on the cross section, which map of a meandering stream best shows the positions of points *X* and *Y*?

- A)
- B)
- C)
- D)

43. The map below shows the path of a river. The arrow shows the direction the river is flowing. Letters *A* and *B* identify the banks of the river.

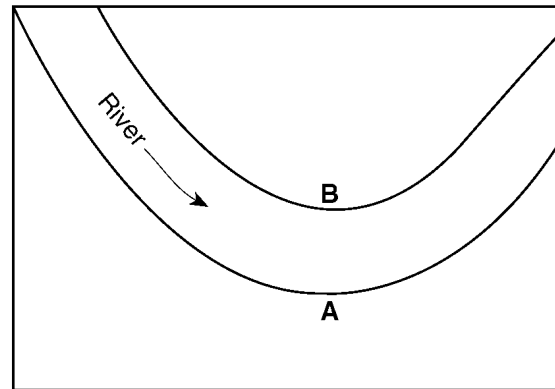

The water depth is greater near bank *A* than bank *B* because the water velocity near bank *A* is

- A) faster, causing deposition to occur  
**B) faster, causing erosion to occur**  
 C) slower, causing deposition to occur  
 D) slower, causing erosion to occur
44. What will be the most probable arrangement of rock particles deposited directly by a glacier?
- A) sorted and layered  
 B) sorted and not layered  
 C) unsorted and layered  
**D) unsorted and not layered**
45. Two streams begin at the same elevation and have equal volumes. Which statement best explains why one stream could be flowing faster than the other stream?
- A) The faster stream contains more dissolved minerals.  
**B) The faster stream has a much steeper gradient.**  
 C) The streams are flowing in different directions.  
 D) The faster stream has a temperature of 10°C, and the slower stream has a temperature of 20°C.
46. The greater the time that stream sediment is transported, the greater the probability that the sediment will become more
- A) angular and smaller  
 B) angular and larger  
**C) rounded and smaller**  
 D) rounded and larger



47. Trees growing on the edge of a river's meander are most likely to fall into the river due to

- A) deposition on the inside of the meander
- B) deposition on the outside of the meander
- C) erosion on the inside of the meander
- D) erosion on the outside of the meander**

48. Base your answer to the following question on the diagram below. The diagram shows points *A*, *B*, *C*, and *D* on a meandering stream.

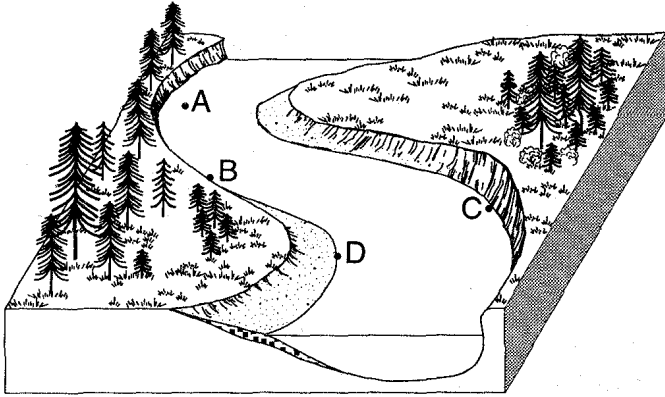

Which material is most likely to be transported in suspension during periods of slowest stream velocity?

- A) gravel
- B) sand
- C) silt
- D) clay**

49. Which graph best represents the relationship between the discharge of a stream and the velocity of stream flow?

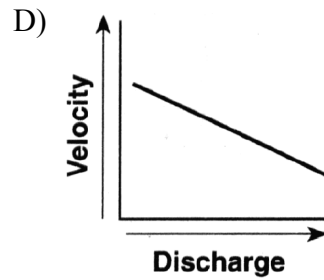
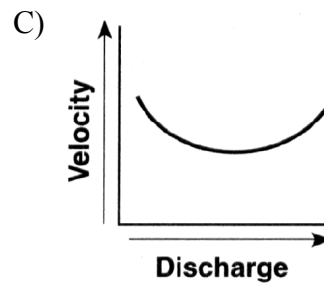
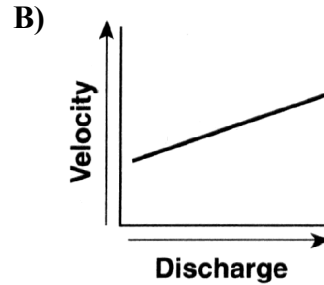
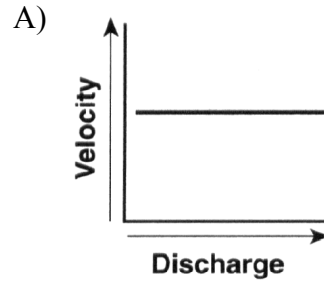

50. Base your answer to the following question on the map below, which shows a portion of a stream that flows southward. Letters *A* through *E* represent locations in the stream. Line *XY* is the location of a cross section.

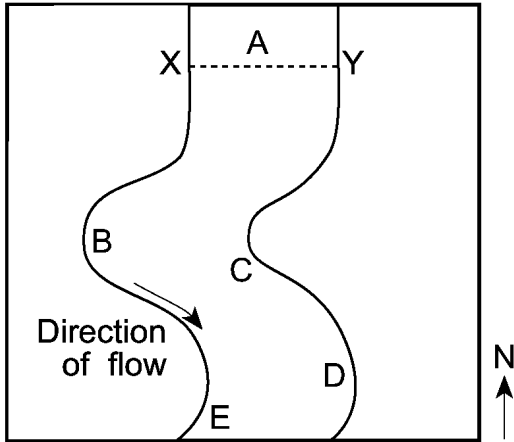

Which cross section along line *XY* best represents the shape of the stream bottom?

- A) B) C) D)

51. The diagram below shows a meandering stream. Measurements of stream velocity were taken along straight line *AB*.

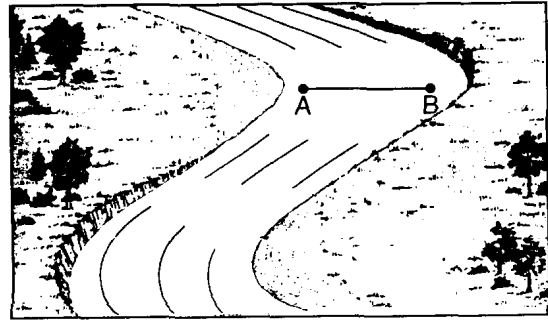

Which graph best shows the relative stream velocities across the stream from *A* to *B*?

- A) B) C) D)

52. Which landscape characteristic indicates a landscape has been formed primarily by streams?

- A) residual soil covering a large area  
 B) coastal sand dunes  
 C) **V-shaped valleys**  
 D) parallel hills of unsorted sediments

53. The diagram below shows a cross section of a river. Letters *A*, *B*, *C*, and *D* represent points in the river.

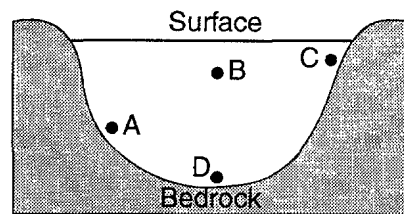

At which point is the water most likely to have the greatest velocity?

- A) *A*    B) ***B***    C) *C*    D) *D*

54. The diagram below shows points *A*, *B*, *C*, and *D* on a meandering stream.

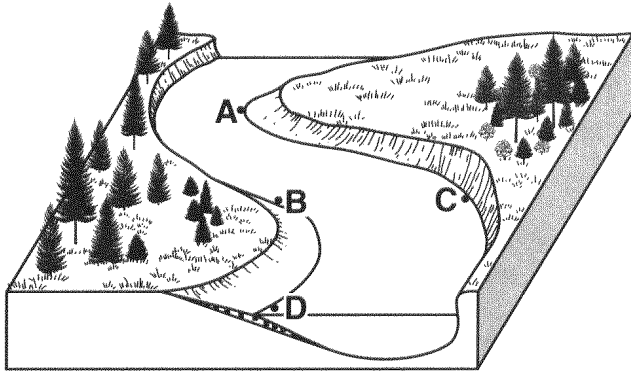

At which point does the greatest stream erosion occur?

- A) *A*    B) *B*    C) *C*    D) *D*
55. In what way is a pebble probably changing as it is carried by a mountain stream?

- A) Its density is decreasing.  
**B) Its mass is decreasing.**  
 C) Its particle size is increasing.  
 D) Its hardness is increasing.

56. The diagrams below represent the map view of a stream and the cross section of the stream at line *XY*. Letters *A*, *B*, *C*, and *D* identify four locations within the stream.

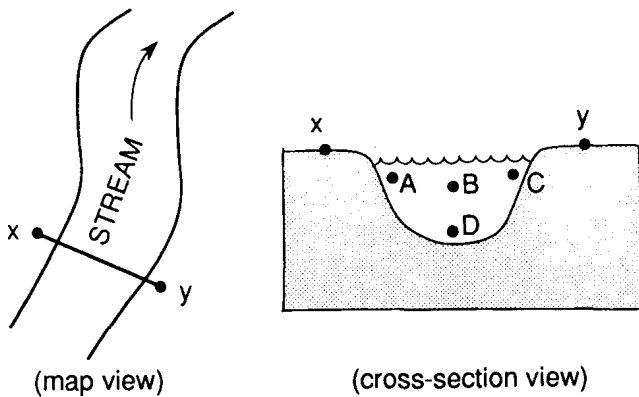

At which location is the water moving fastest?

- A) *A*    **B) *B***    C) *C*    D) *D*

57. The map below represents a view of a flowing stream. The letters identify locations in the stream near the interface between land and water. At which two locations is erosion due to flowing water likely to be greatest?

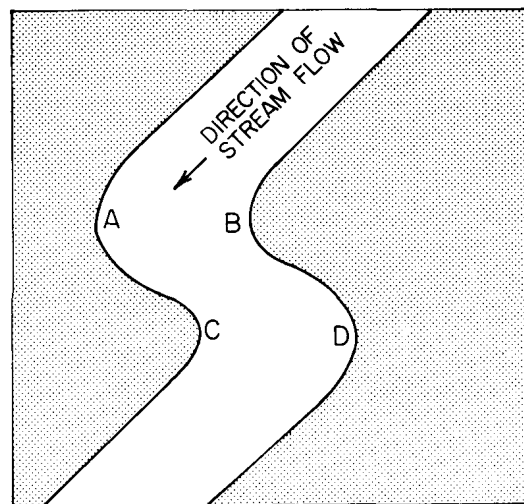

- A) *A* and *B*                      B) *B* and *D*  
**C) *A* and *D***                      D) *B* and *C*
58. Which cross section best represents the valley shape where a rapidly flowing stream is cutting into the bedrock in a mountainous area?

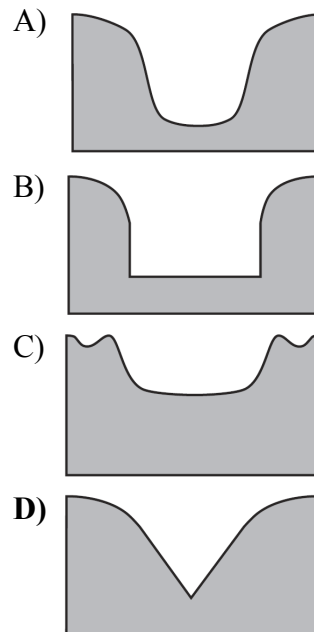

59. Which event is the best example of erosion?

- A) breaking apart of shale as a result of water freezing in a crack
- B) dissolving of rock particles on a limestone gravestone by acid rain
- C) rolling of a pebble along the bottom of a stream**
- D) crumbling of bedrock in one area to form soil

60. In the two diagrams below, the length of the arrows represents the relative velocities of stream flow at various places in a stream. Diagram I shows the different water velocities across the surface. Diagram II shows the different water velocities at various depths.

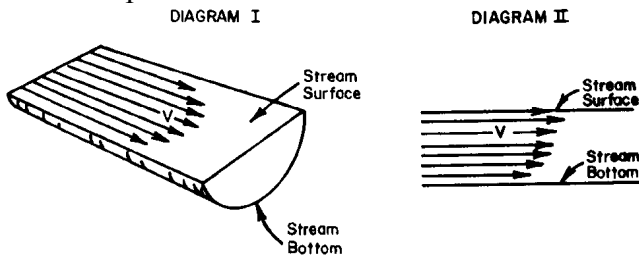

At which location in the stream is the water velocity greatest?

- A) at the center along the bottom
- B) at the center near the surface**
- C) at the sides along the bottom
- D) at the sides near the surface

61. A cross section of Niagara Falls is shown below.

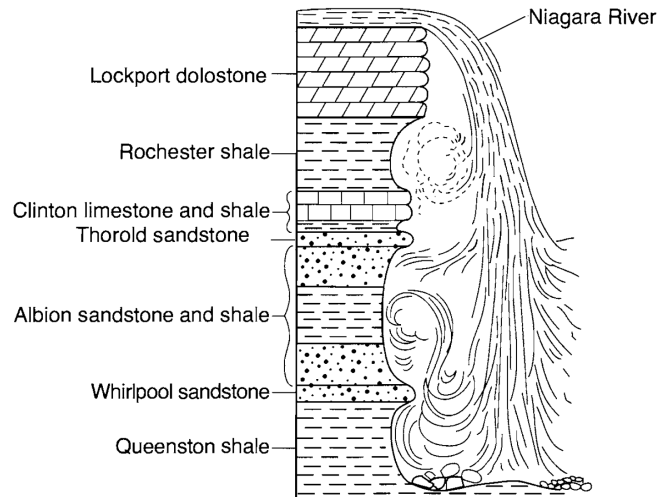

Which two rock units appear to be most resistant to weathering and erosion?

- A) Lockport dolostone and Whirlpool sandstone**
  - B) Rochester shale and Albion sandstone and shale
  - C) Clinton limestone and shale and Queenston shale
  - D) Thorold sandstone and Queenston shale
62. The diagram below shows a section of a meander in a stream. The arrows show the direction of stream flow.

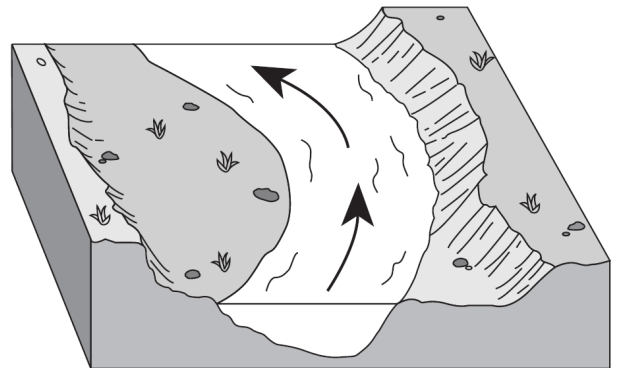

The streambank on the outside of this meander is steeper than the streambank on the inside of this meander because the water on the outside of this meander is moving

- A) slower, causing deposition
- B) faster, causing deposition
- C) slower, causing erosion
- D) faster, causing erosion**