

## **CONTENTS**

Introduction .....	2
Features .....	2
KEYSTATION Overview .....	2
What's in the Box .....	3
Guide to Getting Started .....	4
Hardware Installation .....	4
Software Installation .....	4
USB Driver Installation on the PC .....	5
USB Driver Installation on the Mac .....	6
Setting Up Your MIDI Studio .....	7
Using the KEYSTATION in your Application Software .....	9
KEYSTATION MIDI Functions .....	9
Using the MIDI Functions: .....	10
Default Settings of The KEYSTATION .....	10
Overall Diagram Preview: .....	10
Part A. Operation panel: .....	11
Part B. Rear Panel: .....	13
Specification .....	14
MIDI Implementation Chart .....	15
Limited 90 Day Warranty .....	16

# Introduction

Congratulations on your purchase of the USB KEYSTATION 61 Direct Connect MIDI Controller brought to you by Midiman. When using your KEYSTATION in conjunction with a USB equipped PC or Macintosh computer and appropriate music software, you will be able to discover the wonderful world of Computer Music with a set of complete musical instruments from your sound card, sound modules, or workstation. The USB KEYSTATION 61 gives you full control over MIDI parameters, while utilizing proven Midiman USB MIDI interface technology.

This manual is written to help you become familiar with the powerful features of the KEYSTATION. After reading the manual carefully, you will have a clear understanding of how to transmit different MIDI messages to other instruments and equipment. For ease of use of MIDI implementation, we strongly recommend that you have the manual at hand when you are using the keyboard, especially if you are new to the world of MIDI.

## Features

- The KEYSTATION 61 USB Direct Connect MIDI Controller keyboard provides 61 dynamic keys.
- KEYSTATION uses a 9V DC “wall wart” adapter.
- Connects easily to your computer’s USB port. No tools, and no disassembly is required. When used with USB, the KEYSTATION may be parasitically powered by your computer’s USB port.
- The KEYSTATION provides two MIDI OUT jacks for connecting to MIDI devices from either your computer, or as a standalone MIDI controller.
- There is also a socket for an optional sustain-footswitch.
- Although the KEYSTATION has no built-in sound capabilities, it offers a great variety of useful MIDI functions.

## KEYSTATION Overview

The USB KEYSTATION 61 is a fully functional MIDI controller. Its 61 keys can be set to play any octave, while its compact size makes it one of the ultimate portable keyboard controllers. Virtually any type of MIDI controller information can be sent from the KEYSTATION to your computer, using the power and convenience of the Mac or PC computer’s USB port. Additionally, the KEYSTATION can operate as a “standalone” MIDI controller, independent of the computer. The rear panel MIDI port marked “keyboard” is used for this purpose.

Contained within the KEYSTATION is a USB MIDI interface. Simply plug the KEYSTATION into your computer’s USB port, install the included drivers and

enable the MIDI interface within your music software. This combination of a versatile keyboard controller and a USB MIDI interface allows you to record and control MIDI information within your music application, plus adds a MIDI output port to which you can connect a MIDI sound module or drum machine. The rear panel MIDI port marked “USB” is used for this purpose.

The KEYSTATION may be powered “parasitically” from the voltage it receives from the USB port. For the most consistent performance, we recommend using the power supply when using the KEYSTATION in conjunction with your computer’s USB port. To power only from the USB port, plug the KEYSTATION directly into the USB port on the computer or into a powered USB hub. When using the KEYSTATION in stand alone mode, power must be applied to the unit from the power supply.

On a PC: You must be running Windows 98 or higher to properly use the KEYSTATION. Also, your motherboard must support USB or you will need to install a PCI to USB host adapter to provide the USB ports. It is possible for a motherboard to support USB and yet not have the physical port connectors installed. A simple USB back panel extender can be purchased at a computer supply store and can be installed easily to provide USB port connectors.

On an Apple Computer: Your Apple must support USB with the physical ports present. Standard iMac’s or G3/G4’s with USB ports will work just fine. If you choose to use a PCI to USB card for the Mac, then a Mac OS that supports USB will also be required, i.e. OS 8.6 or higher.

**IMPORTANT: For the Mac an OMS MIDI driver is provided. You MUST have a sequencer that supports OMS, and have OMS properly installed in order to use the KEYSTATION.**

## **What’s in the Box**

Included in your KEYSTATION, you should find:

1. This manual.
2. PC and Mac driver disk.
3. The KEYSTATION 61 USB Direct Connect MIDI Controller.
4. One (1) standard USB cable.
5. One (1) 9v DC 500mA “wall-wart” power supply. Use only this power supply or one of equal value with your KEYSTATION.

## **Guide to Getting Started**

Here is an outline of the steps needed to begin using your KEYSTATION on either a Mac or a PC:

1. Attach the KEYSTATION to your computer (see “Hardware Installation”).
2. Install the Driver (see “Software Installation”).
3. Hook your sound module to the KEYSTATION (see “Setting Up Your MIDI Studio”).
4. Configure the KEYSTATION in your application software (see “Using the KEYSTATION in your Application Software”).

## **Hardware Installation**

Installing your KEYSTATION involves simply attaching it to your USB port using the standard USB cable that is included. We recommend that you power down (turn off) your computer for a first time installation. If you are using the KEYSTATION in USB mode the power supply is not required. The computer’s USB port provides the power to run the KEYSTATION. The wall-wart” is only necessary for use in the standalone mode. However, when the KEYSTATION receives its power from the USB port, we recommend either plugging directly into the computer’s USB port (not the keyboard’s port), or into a powered USB hub.

Find a good spot around your computer station to place the KEYSTATION. The USB port on your computer is a small (1/8” x 3/8”), rectangular connector (A) and is usually found in a group of two. The other end (B) of your USB cable is ‘more square’ (1/4” x 1/4”) in shape, and should fit easily into the USB connector on your KEYSTATION. Next, power up your computer and proceed to the next section, “Software Installation.”

Take the (A) end of the USB cable and plug it into the USB port on the back of your computer. Take the (B) end of the USB cable and plug it in to the USB port on the back panel of the KEYSTATION.

## **Software Installation**

MIDI application software communicates with devices such as the MIDI interface contained within the KEYSTATION via software known as “drivers.” This software driver is a special, dedicated program that makes a MIDI interface accessible to an application. On the included driver disk, Midiman supplies the drivers that enable you to use the KEYSTATION with either Windows or Opcode’s OMS for Mac users. Both KEYSTATION drivers are supplied on the included dual format CD.

## USB Driver Installation on the PC

This driver for the KEYSTATION USB interface requires Windows 98 or higher. Please make sure that Windows 98, ME, or 2000 is installed on your system, and that your USB port is enabled. Check your computer manual for more information.

1. Boot Windows with the KEYSTATION (powered on) connected, or connect it after Windows has been booted.
2. When the Add New Hardware Wizard reports that it detected an Unknown Device, click "Next."
3. On the next screen select the "Search for the best driver for your device" item & click "Next".
4. Indicate to Windows where to look for the driver installation files. Select "Choose Path," then type in (or browse until you locate) [your CD ROM drive letter]:\KEYSTATION\USB. In most cases this will be d:\KEYSTATION\USB, but your CD drive may be a different drive letter.
5. On the next screen, Windows will indicate it has searched for the driver files for the "Midiman USB KEYSTATION Loader" and is now ready to install the driver. Click the "Next" button to continue.
6. Windows will copy files and then indicate it has finished installing the software that your new hardware device requires. Click the "Finish" button.
7. Next you will see Windows indicate that it has found another Unknown Device & then see it automatically install the software for the "Midiman USB KEYSTATION Midi Driver".

Hold on, we're not done yet.

8. The Add New Hardware Wizard will once again report it has detected an Unknown Device, click "Next".
9. On the next screen select the "Search for the best driver for your device." item & click "Next".
10. Indicate to Windows where to look for the driver installation files (this should be the exact same place you had Windows look for the previous software), the click the "Next" button.
11. On the next screen, Windows will indicate it has searched for the driver files for the "Midiman USB KEYSTATION Midi Driver" and is now ready to install the driver. Click the "Next" button to continue.
12. Windows will copy files and then once again indicate it has finished installing the software that your new hardware device requires. Click the "Finish" button.

The software drivers are now all loaded and functional. If you look in the Device Manager, you will find 2 parts for the KEYSTATION driver; one under the "Universal Serial Bus" controller group and the other under the "Sound, video, & game controllers" group.

Your KEYSTATION is ready for use. Refer to the sections "Setting Up Your MIDI Studio" and "Using the KEYSTATION in your Application Software" for more information.

## USB Driver Installation on the Mac

You must first install Opcodes's OMS. This is available on the MIDISPORT drivers page of our website, or can be installed from the driver CD by opening the OMS folder and then double clicking the OMS install icon.

This release version of the KEYSTATION drivers requires Macintosh operating system OS 8.6 or higher. This is offered by Apple as a free update to OS 8.5 owners. Please check the Apple website at <http://asu.info.apple.com> for update information.

OMS is a MIDI manager program that is made by Opcode. We have included it on the CD disk for your convenience, and also offer it as a free download from our website's MIDISPORT drivers page. OMS is required to run the KEYSTATION on the Macintosh, and it is important that you install OMS before running the KEYSTATION Installer. Locate the OMS installer program on this CD in the OMS 2.3.7 folder, and simply double click its icon to install OMS. Once this has been successfully completed, you can move on to the next step- the KEYSTATION 1.0 Installer.

**FOR FIRST TIME INSTALLS: If you power up your Mac with the KEYSTATION attached and powered up, you will receive a message that an "unknown USB device has been detected. Click OK and proceed with the driver installation. You may also install the drivers first, and then plug in the KEYSTATION.**

1. Insert the Driver Software CD. Open the KEYSTATION folder, then the USB folder. There, you will find the KEYSTATION Installer program. If your unit came with a floppy, you will first find a "KeystationMac" folder, then the USB folder.
2. Run the KEYSTATION Installer by double clicking on it. This installs all of the KEYSTATION's extensions as well as the KEYSTATION OMS Driver. However, YOU MUST HAVE OMS INSTALLED FIRST BEFORE YOU RUN THIS INSTALLER PROGRAM. Otherwise, the KEYSTATION OMS Driver will not be placed in the OMS folder.

Once installed, you should have 2 KEYSTATION extensions in your extensions folder, which resides in your System folder. They are: 1) KEYSTATIONDriver; 2) KEYSTATIONShim. The installer will also place the KEYSTATION OMS Driver in the OMS folder, which also resides in your system folder. Now it is time to configure OMS.

Go to the Control Panel or Chooser under the Apple Menu, and make sure AppleTalk is turned off (this is recommended, although OMS will sense that it is on and prompt you to turn it off). If you are installing your KEYSTATION driver and configuring OMS for the first time, follow these instructions to configure OMS.

## **First Time OMS Configuration Instructions:**

1. In the Opcode folder, which you will find on your hard drive, locate the OMS Applications folder, then OMS Setup. Double click on OMS Setup.
2. OMS will inform you that it has not yet been configured. Click OK.
3. The Create A New Studio Setup dialog box now appears. Click OK.
4. The “OMS Driver Search” box asks you to choose the port on which you’ve attached the KEYSTATION (either Modem or Printer). DO NOT choose a port (since we’re using USB), just click “Search.” OMS begins Searching. IMPORTANT: If the USB cable is not correctly hooked up to the KEYSTATION, setup will fail.
5. “OMS Driver Setup” shows the KEYSTATION in a list when OMS successfully finds the driver. Click OK. OMS will now define (shows “Identifying”) the KEYSTATION output port. Please note that OMS sees the KEYSTATION port A as port 1 (this is an OMS idiosyncrasy).
7. The “OMS MIDI Device Setup” dialog box will appear showing the KEYSTATION’s output port with an open check box to the left of the port. You will now have to check this open box to enable the output port. Click on OK.
8. Next, the “My Studio Setup” appears with a file save dialog box over it. You will now need to name and save your new Studio Setup (or use the default name) before you can assign an instrument to the KEYSTATION’s output. Assign your instrument (this step is optional) and you are done.
9. Your KEYSTATION is ready for use.

You can run the OMS ‘Test Studio’ utility by going to the ‘Studio’ menu and releasing the mouse on “Test Studio”. Playing a note on your keyboard will give you an audio message from your computer, “MIDI received,” while the arrow pointing to the keyboard icon flashes. Clicking on the keyboard icon with the mouse pointer will send a tone cluster to the KEYSTATION output port. The LED will light, and the sound module connected to the KEYSTATION MIDI Out port should play the chord.

You may now exit OMS Setup by quitting the application. The rest is up to configuration within your music software. Generally, this means selecting “OMS Compatibility,” or “Open Music System” for your MIDI system setup.

## **Setting Up Your MIDI Studio**

A typical MIDI system set-up would include your KEYSTATION, a computer, MIDI sequencing software and/or a MIDI compatible sound module. This type of set-up can be connected as follows:

1. The KEYSTATION is connected to the computer via the USB port connectors, using the supplied USB standard cable.
2. The KEYSTATION will play the synthesizer that is part of an internal sound card, as well as any software synthesizers that are installed in your system.

This will depend on how you set up your software (see section “Using the KEYSTATION in your Application Software.”) The audio output of the sound card can be plugged directly into a sound system, or into a mixer, which is then connected to a sound system.

3. The MIDI Output of the KEYSTATION is connected to the MIDI In of a sound module. The audio output of the sound module can be plugged directly into a sound system, or into a mixer, which is then connected to a sound system.

In the set-up below, the KEYSTATION is being used as a MIDI controller as well as a MIDI interface, inputting MIDI data to the computer and its application software, and outputting MIDI to a sound module from which sounds will be produced. The KEYSTATION as a controller may also send MIDI information to an existing internal soundcard’s MIDI synthesizer or any installed software synthesizer, outputting the audio from the computer soundcard.

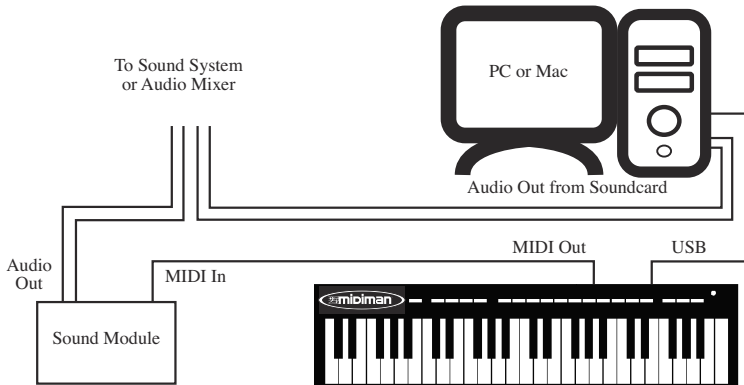

In this scenario, it may not be necessary to apply external power to the KEYSTATION. With the power switch set to “Power Off,” the KEYSTATION receives power from the USB port on your computer. It is recommended that you either plug directly into the USB port on the computer, or use a powered USB hub. You may also choose to use external power from the power supply that is provided.

Additionally, the KEYSTATION may be used as a “standalone” keyboard controller, independent of the computer and its USB port. In this case, the KEYSTATION must receive power from the power supply, and by switching the power on from the rear panel. A setup such as this may be used in a performance situation, or when you wish to use the keyboard without the computer.





## Using the KEYSTATION in your Application Software

Once the KEYSTATION driver has been installed, you will need to configure your MIDI application software to utilize the KEYSTATION. The manner in which this is done varies between applications, so we can just cover the basics here.

Generally with both the Mac and PC, most MIDI applications have a MIDI port configuration or settings dialog box, sometimes called “MIDI Devices” or “MIDI Setup.” It is within this dialog box that you will select or enable your MIDI input and output devices.

If the KEYSTATION drivers are properly installed, then the port selection in this case will be the KEYSTATION In-A (or “Port 1” on the Mac) in the input column, and then KEYSTATION Out-A (or Port 1) in the output column. Input A (or Port 1), corresponds to the information that will be sent from the KEYSTATION keyboard to your computer. Output A (or Port 1), corresponds to the MIDI information sent from your music application to the physical MIDI output on your KEYSTATION. Make sure that those items are highlighted or checked. The output port that you select on a specific MIDI track within your sequence will output MIDI information to the keyboard or sound module that is attached to that port.

## KEYSTATION MIDI Functions

**MIDI** is the acronym for **Musical Instrument Digital Interface**, which makes all digital musical instruments equipped with this standardized interface able to exchange their MIDI data or “talk to each other.”

To explain how MIDI works on your instrument in more detail, the following illustrations outline the MIDI functions of the KEYSTATION, which allow you to connect the keyboard to other MIDI instruments and to your computer. The versatile MIDI capability of the KEYSTATION will offer you tremendous power in a MIDI environment.

## Using the MIDI Functions:

1. Connecting the keyboard to other MIDI instruments:  
To transmit MIDI data from your keyboard to other professional MIDI instruments, please purchase a MIDI cable and use it to connect the MIDI OUT jack of your KEYSTATION to the MIDI IN jack of the other instrument. Make sure that the MIDI port "transmit" channel within you music application matches the MIDI "receive" channel of the other instrument.
2. Please refer to the diagram in the section, "Setting Up Your MIDI Studio" for the MIDI and audio connections.

## Default Settings of The KEYSTATION

The KEYSTATION will always select the following values for their parameters when the power is turned on.

- Transmit MIDI Channel no. 1.
- Default Octave will be from C2(36) to C6(84)
- Default After Touch value will be 0
- Default Velocity value will be 0
- Default Reverb Depth value will be 64
- Default Pan Pot value will be 64
- Default Volume value will be 127
- Default CC Data value will be 0
- Default CC no. value will be 0
- Default Control Change (CC-00=0, CC-32=0) message will be transmitted.
- Default Program Change (PG=1) message will be transmitted.

## Overall Diagram Preview:



## Part A. Operation panel:

1. Using the Pitch Bend Wheel: The Pitch Bend wheel is used for raising or lowering the pitch of a voice during performance. The range of pitch values depends on the sound generator (sound card or module) being used. Please refer to the manuals of your devices for information on how to change the Pitch Bend range. To bend the pitch up, move the wheel away from you. To bend the pitch down, move the wheel towards you.
2. Using the Modulation Wheel: It is very common to use the modulation wheel to change the intensity of effects: mainly Vibrato (pitch change), Tremolo (change the volume), and Modulation (change the tone). The Modulation wheel produces a vibrato effect shortly after the sound is generated. It is most effective for voice such as saxophone, strings, and oboe.
3. Data Entry Slide: This slide controller allows you to adjust the following parameters: Volume, Velocity, Chorus, Reverb, Pan pot, and Aftertouch directly from your keyboard.
4. MIDI / SELECT button: Use this button to select different MIDI commands on certain keys from your keyboard.

KEYSTATION provides several groups of MIDI commands as follows:

**MIDI Channels group:** Pressing the MIDI/SELECT button and then pressing the MCH (MIDI Channel) key allows you to select the transmitting channel for your keyboard. The default Channel is 1 when the keyboard's power is turned on. Pressing the MIDI/SELECT button, MIDI Channel 2 & then the MIDI/SELECT button changes the MIDI transmit channel from 1 to 2.

**Assignment data entry group:** Pressing the MIDI/SELECT button then pressing the key of aftertouch (or velocity, or reverb depth, or chorus depth, or pan pot, or volume, or CC data) and then moving the data entry slider, allows you to select the transmitting value of the function. For example, if you want to change the value of aftertouch, first press MIDI/SELECT button and aftertouch key. Second, change the data entry slider to the value you want and finally press the MIDI/SELECT button again to finish the change.

**Octave group:** By pressing the MIDI/SELECT button and the octave key, you will shift the active keyboard range one octave higher, or lower. For example, if you want to change the octave 2 octaves down, press MIDI/SELECT button and -2 key, then press MIDI/SELECT button to finish the change.

**Reset key:** Pressing the MIDI/SELECT button and the Reset key will send out a message to return all external MIDI instruments to their default setting.

**Control Change data entry by Numeric keypad:** KEYSTATION allows you to use the numeric keys to specify your Control Change DATA parameter instead of data entry slide. By pressing the MIDI/SELECT button and CC data key, and then the required number, and finally the Enter key to finish. For example, if you want to make Control Change 7 to a value of 123:

- 1) Press MIDI/SELECT button;
- 2) press CC No.;
- 3) choose 7 on numeric keypad;
- 4) press enter key to specify Control Change as 7;
- 5) press CC data key;
- 6) press number key 1, 2, and 3;
- 7) press enter key to specify value 123 then press MIDI/SELECT button to finish this action.

**Please note:** After you press the enter key, the LED display will show “—“ to indicate that you pressed enter key and will not disappear until you press MIDI/SELECT button to finish your choice. After you press the cancel key, the LED display will show blank to indicate that you pressed the cancel key, and will not disappear until you press the MIDI/SELECT button to finish your choice.

**Program key:** Pressing the MIDI/SELECT button and the Program key, then numeric keys, and finally the enter key, you can select any patch number between 1 and 128. For example, if you want to change voice to 67 (TenoSax). Pressing MIDI/SELECT button and 67 on numeric keys then enter key and MIDI/SELECT button again to finish this action.

**Please note:** after you press the enter key, the LED display will show “—“ to indicate that you pressed enter key and will not disappear until you press MIDI/SELECT button to finish your choice. After you press the cancel key, the LED display will show blank to indicate that you pressed the cancel key, and will not disappear until you press the MIDI/SELECT button to finish your choice.

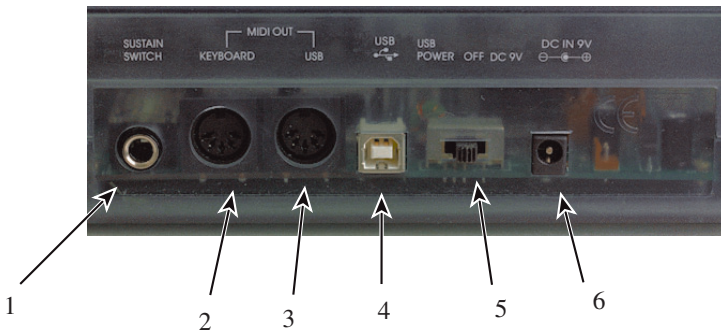

## Part B. Rear Panel:

1. Sustain jack: This jack allows you to connect an optional footswitch to the keyboard. When the footswitch is depressed, notes played on the keyboard will continuously sound as long as the footswitch is held, while MIDI controller information is sent from the KEYSTATION.
2. MIDI Out jack, "Keyboard": This standard MIDI jack is a direct MIDI out from the keyboard in "standalone" mode, and is used to send MIDI messages to another MIDI instrument (such as sound module).
3. MIDI Out jack, "USB": This standard MIDI jack receives its source from the computer when software is set to "KEYSTATION MIDI Out, and is used to send MIDI messages to another MIDI instrument (such as sound module).
4. USB port: This USB connector jack is used to connect the KEYSTATION to the computer's USB port using a standard USB cable (included).
5. Power switch: The 3-position power switch turns the keyboard's power to external 9V power, power off, or USB power. When set to "USB Power" the KEYSTATION will receive its power "parasitically" from the USB port when the computer is powered on. When the power is turned on, the keyboard will start at the default setting.
6. Power jack: This jack is used to connect the keyboard to the included "wall-wart" 9vDC 500mA power supply.

## Specification

Model: USB KEYSTATION 49

Keyboard	61 dynamic keys.
Simultaneous Note output (Reverse priority)	10 notes
Control switches	MIDI Channel Reset Octave -2, -1, center , +1, +2 Program Change CC-00/CC-32(For GS Bank Selection), CC-No.(Generic CC Assignment) <sup>°C</sup> CC-Data <sup>°C</sup> Data Entry After Touch Assignment, Data Entry Velocity Assignment, Data Entry Reverb Send Level Assignment, Data Entry Chorus Send Level Assignment, Pan Pot Assignment(CC-10), Volume Assignment(CC-07) <sup>°C</sup> CC-Data <sup>°C</sup> Numerical Keys x10 Enter Cancel Pitch Bender Wheel, Modulation Wheel, Data Entry slide <sup>°C</sup>
External Control Terminals	MIDI Out (DIN), Sustain, Game port connect (for power and MIDI) Power SW.
Display	7 segment LED x 3
Dimensions	92x21.5 x 7.5(cm)
Weight	3.38 kg
Power source	DC 9V 500 ma USB Port

# MIDI Implementation Chart

Model: KEYSTATION Version: 1.0

Function	Transmitted	Recognized	Remarks
<b>Basic Channel</b>			
Default	1	x	
Changed	1-16	x	
<b>Mode</b>			
Default	Mode 3	x	
Messages	x	x	
Altered	*****	x	
<b>Note Number</b>	12-108	x	With Octave Change
<b>True Voice</b>	*****	x	
<b>Velocity</b>			
Note ON	o	x	
Note OFF	x	x	
<b>After Touch</b>			
Key's	x	x	
Ch's	o	x	
<b>Pitch Bender</b>	o	x	
<b>Control Change</b>	o	x	
<b>Prog Change</b>			
:True #	1-128	x	
:CC-00,	*****	x	
:CC-32	0-127	x	
<b>System Exclusive</b>	x	x	
<b>System Common</b>			
:Song Pos	x	x	
:Song Sel	x	x	
:Tune	x	x	
<b>System Real Time</b>			
:Clock	x	x	
:Commands	x	x	
<b>Aux Message</b>			
:Local ON/OFF	x	x	
:All Notes OFF	o	x	Send with Reset.
:Active Sense	o	x	
:Reset	o	x	Send with Reset.
<b>Notes:</b>			o=Yes,x=No

## **Limited 90 Day Warranty**

MIDIMAN warrants that this product is free of defects in materials and workmanship under normal conditions for 90 days, so long as the product is: owned by the original purchaser; the original purchaser has proof of purchase from an authorized MIDIMAN dealer; and the purchaser has registered his/her ownership of the product by sending in the completed warranty card.

In the event that MIDIMAN receives written notice of defects in materials or workmanship from such an original purchaser, MIDIMAN will either replace the product, repair the product, or refund the purchase price at its option. In the event any repair is required, shipment to and from MIDIMAN and a nominal handling charge shall be born by the purchaser. In the event that repair is required, a Return Authorization number must be obtained from MIDIMAN. After this number is obtained, the unit should be shipped back to MIDIMAN in a protective package with a description of the problem and the Return Authorization clearly written on the package.

In the event that MIDIMAN determines that the product requires repair because of user misuse or regular wear, it will assess a fair repair or replacement fee. The customer will have the option to pay this fee and have the unit repaired and returned, or not pay this fee and have the unit returned unrepared.

The remedy for breach of this limited warranty shall not include any other damages. MIDIMAN will not be liable for consequential, special, indirect, or similar damages or claims including loss of profit or any other commercial damage, even if its agents have been advised of the possibility of such damages, and in no event will MIDIMAN's liability for any damages to the purchaser or any other person exceed the price paid for the product, regardless of any form of the claim. MIDIMAN specifically disclaims all other warranties, expressed or implied. Specifically, MIDIMAN makes no warranty that the product is fit for any particular purpose.

This warranty shall be construed, interpreted, and governed by the laws of the state of California. If any provision of this warranty is found void, invalid or unenforceable, it will not affect the validity of the balance of the warranty, which shall remain valid and enforceable according to its terms. In the event any remedy hereunder is determined to have failed of its essential purpose, all limitations of liability and exclusion of damages set forth herein shall remain in full force and effect.