

# **ADVANCE LIFTS**

---

## **100 SERIES STRETCH WRAP MACHINES OWNERS MANUAL**

**CAUTION!**

THIS MANUAL IS AN IMPORTANT DOCUMENT IT SHOULD BE KEPT WITH THE MACHINE OR LOCATED WHERE READILY AVAILABLE TO OPERATORS AND MAINTENANCE PERSONNEL FOR REFERENCE PURPOSES.



INSTALLATION, OPERATION AND MAINTENANCE MANUAL  
FOR THE FOLLOWING STRETCH WRAPPER MODEL NUMBERS

Throughout this manual, units are referred to by series. Each series has special installation, maintenance and safety requirements.

100 Series Stretch Wrappers:

SW100L40, SW10H60

SW125L40, SW125H60

SW150L40, SW150H60

SW175L40, SW175H60

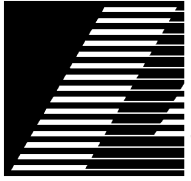

# ADVANCE LIFTS

---

## Stretch Wrapper Installation, Operation and Maintenance Manual

In any correspondence with your distributor or the factory you will need the following information:

Model Number \_\_\_\_\_ Serial Number \_\_\_\_\_

Installation location: \_\_\_\_\_  
\_\_\_\_\_  
\_\_\_\_\_

---

Distributor Information: \_\_\_\_\_  
\_\_\_\_\_  
\_\_\_\_\_  
\_\_\_\_\_

**Advance Lifts Inc.**  
**701 S. Kirk Road**  
**St. Charles, IL 60174-3428**  
**Toll Free 1-800-843-3625**  
**Sales Fax 1-630-584-9405**  
**Parts and Service Fax 1-630-584-6837**  
**E-mail: [Parts@advancelifts.com](mailto:Parts@advancelifts.com)**

\*Advance Lifts Inc. furnishes one manual with each unit. Additional manuals are available at \$25.00 each.

## SECTION 2. INDEX & INTRODUCTION

Identification.....	Section 1
Index & Introduction .....	Section 2
*Responsibilities of Owners/Users .....	Section 3
*Installation Instructions .....	Section 4
*Operating Instructions .....	Section 5
*Maintenance Instructions .....	Section 6
Electrical Details .....	Section 7
Schematics	
Identification and Label Placement .....	Section 8
Troubleshooting Hints .....	Section 9
Warranty .....	Section 10
Parts Lists.....	Section 11

### INTRODUCTION

Congratulations, the equipment that you have purchased is of the highest quality. Your Advance Lifts Stretch Wrapper will provide you with many years of trouble free service in return for the minimal maintenance described in this manual.

Please be sure that no individual is allowed to operate the stretch wrapper until they have been fully familiarized with operating instructions in this manual. Also insure that at least one person at the stretch wrapper site is familiar with the maintenance section of this manual and is assigned responsibility for doing the maintenance on a regular basis.

Please note that the stretch wrapper has a metal nameplate attached to it that contains information such as the model number, capacities and the serial number. Do not remove the nameplate. Be sure that load weight never exceeds the capacity shown on the nameplate or they may cause damage to the stretch wrapper or injure personnel. Also, be sure to have the serial number of the stretch wrapper handy if you have to call the factory. The serial number identifies your specific stretch wrapper and will allow factory personnel to give you the most thorough and timely assistance possible.

This manual is under constant review and we would appreciate any constructive suggestions that may enhance its usefulness. Please send your suggestions to Advance Lifts Inc. Stretch Wrappers, Attn: Service Manager

Thank you for purchasing our product.

\*Mandatory reading before attempting installation.

### SECTION 3. RESPONSIBILITIES OF OWNERS & USERS

**Owner responsibility: The owner shall be responsible for:**

1. Ensuring that the installation of the advance stretch wrapper is in conformance with applicable local, state and federal codes and ordinances.
2. Providing a properly maintained stretch wrapper that meets all applicable safety standards.
3. Setting up and following a program of training and instructing employees in safe methods of work before assigning them to operate or maintain a stretch wrapper. The employer shall maintain records of this training to include the day(s) of the training and the content of the training received. The employer shall ensure, by adequate supervision, that correct operating and maintenance procedures are understood and followed. The employer should refer to the manufacture's and installer's instructions for this purpose.
4. Operating the stretch wrapper in accordance with the design specifications as recommended by the manufacturer.
5. Repairing, prior to operation, all malfunctions or breakdowns that results in unsafe operating conditions of the stretch wrapper.
6. Specifically inspecting safety interlocks, switches and other protective devices, to ensure that these devices are not disabled or bypassed, and to not permit the stretch wrapper to be operated unless these devices are fully functional. These inspections will be in accordance with an established program of periodic and regular inspections that are recorded along with a complete history of all maintenance performed on the equipment.

**User Responsibility: The User shall be responsible for:**

1. Using all applicable safety features provided on the stretch wrapper.
2. Operating, maintaining and using the stretch wrapper only after being properly instructed and trained in accordance with the instructions given in item # 3 above.
3. Immediately reporting any damage to or malfunction of the stretch wrapper to the employer or responsible authority.
4. Ensuring that all individuals are aware and clear of the operation and pinch point areas before actuating the controls.
5. Not placing hands or fingers in or near moving portions of the machine during use.
6. Ensuring that all individuals are standing clear of the rotating load and moving carriage during the stretch wrapping operation.
7. Ensuring that no one disables or bypasses any safety interlocks, switches and other protective devices and that the stretch wrapper is not operated unless these devices are fully functional.

## SECTION 4. INSTALLATION INSTRUCTIONS

### Series 100 Stretch Wrap Machines

#### **Equipment and Supplies Required:**

1. Equipment to maneuver the Advance Lifts Stretch Wrapper into position. All units are manufactured with forklift pockets for maneuvering.
2. An electrical fused disconnect (if required), wiring and fittings for the branch circuit and the appropriate receptacle. While not necessary, Advance Lifts recommends that this unit be connected to a dedicated circuit.

#### **Shipping and Packaging Warning:**

The stretch wrapper is shipped from the factory in one piece. No assembly is required. The unit comes with a pre-wired electrical system that is ready to plug in and is fully tested at the factory for ease of installation. However, if the installer does not carefully follow these installation instructions, it is possible to damage the equipment, so please read this entire procedure before proceeding with the installation.

#### **Equipment Location:**

1. The floor should be flat and level concrete that is strong enough to support the weight of the unit.
2. The equipment is suitable for indoor operation only.
3. Advance recommends a minimum of 3 feet clearance at the sides and behind the stretch wrapper. An area in the front or the side of the stretch wrapper must be obstruction free to accommodate the loading of pallets. The area around the controls of the unit must be kept clear in order to prevent tripping hazards during the loading and wrapping process.

#### **Unloading and Final Positioning:**

1. The preferred system of unloading is with a fork lift. Most stretch wrappers are shipped attached to a shipping pallet or skid. Remove the unit from the truck using the shipping skid. Once the unit is off the truck and safely on the floor, remove all the banding and straps holding the unit to the skid.
2. There are fork pockets located on all Advance stretch wrappers specifically for the purpose of lifting and moving the units. Forks should be spaced so as to slide into both fork pockets and should be inserted as far as possible. Care should be taken to prevent damage to the machine with the forks. Lift the stretch wrapper off the skid and place it in the final location.
3. After the unit is in position, clearance around the unit should be checked. A minimum of 3 feet is recommended.
4. Optionally, drill the concrete and insert the four (4) anchors at the locations provided in the base and tighten securely.
5. Assure power outlet voltage is the same as the voltage identified on the machine. Depress E-Stop button (Model 150 & 175) and connect machine to electrical power.

## SECTION 5. OPERATING INSTRUCTIONS, FILM LOADING

### Model 100

This model is designed to use hand wrapping film with a core tube which extends beyond the film edge.

### Model 125

This model is designed to use 12-18" wide hand wrap film. Any standard film gauge is acceptable for use with this machine. Film tensioning is by means of a frictional brake. Wrap tension can be varied by rotating an adjustment knob located on the top of the film carriage. Rotating the knob clockwise increases film tension. To load film, remove the friction adjustment knob assembly by rotating it counter clockwise until it disengages from the carriage. Slide film roll down over shaft until it engages the lower film support bearing at the bottom. Replace top film bearing and adjustment knob assembly and tighten until the desired tension is obtained.

### Model 150

This model is designed to use 20" wide industrial film with a 3" core. Any standard film gauge is acceptable for use with this machine. Film tensioning is by means of a frictional brake. Wrap tension can be varied by rotating an adjustment knob located on the top of the film carriage. Rotating the knob clockwise increases film tension. To load film, remove the friction adjustment knob assembly by rotating it counter clockwise until it disengages from the carriage. Slide film roll down over shaft until it engages the lower film support bearing at the bottom. Replace top film bearing and adjustment knob assembly and tighten until the desired tension is obtained.

### Model 175

This model is designed to use 20" wide industrial machine film with a 3" core. To load film, rotate the core retainer up, load film on stationary lower retainer then rotate the top retainer back into place to secure film. This unit utilizes a geared mechanical pre-stretch which must be loaded, in accordance with the illustration below. Due to the nature of pre-stretch, heavier gauge films are recommended for use.

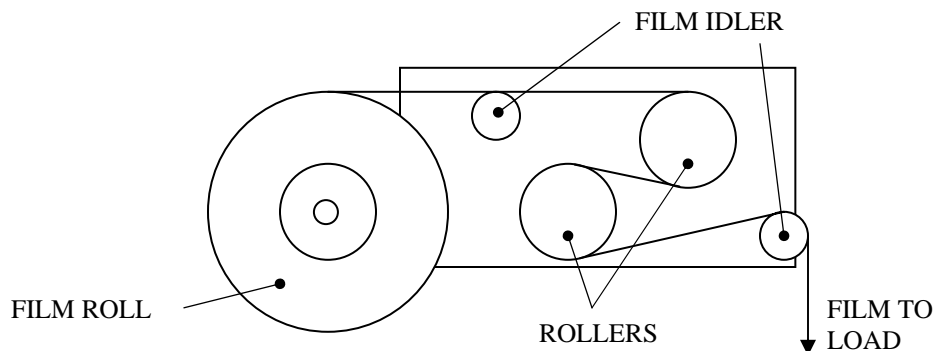

Top view of film loading model 175 (only)

## SECTION 5. OPERATING INSTRUCTIONS (Continued)

### MODELS 100 & 125

1. Place a loaded pallet on the turntable platform making sure that the load is centered. Loads should be centered before rotating the unit as this will help insure even wear on all moving parts and reduce the possibility of items falling off the load being wrapped.
2. Place the loose end of the stretch wrap film onto the product, trapping the film so that it will not pull out.
3. Make certain there are no obstructions around or under the stretch wrapper. Make sure that the power cord and footswitch cord are not in contact with the pallet or product.
4. Raise the stretch wrap film holder to the desired starting position and hold. Depress the footswitch and start the turntable.

#### WARNING !

Operators must be alert to all personnel in the vicinity of the unit to avoid any surprises to these personnel in regard to movement of position of the unit at any time. Never operate the unit if you cannot see it or the personnel around it.

5. As the product begins to turn, adjust tension of the stretch wrap film dispenser to achieve the desired wrapping tension.
6. When the desired amount of film has been placed on the load, remove pressure from the footswitch.
7. After the platform has stopped rotating, break the film midway between the product and attach film tail to product.
8. The pallet may now be removed from the platform.

#### CAUTION !

Exercise caution when removing the load from the unit. Make sure that the device that is being used to remove the load picks up only the load and pallet and not the turntable platform.

### CONTROL FUNCTIONS:

**Footswitch:** Depress to rotate, release to stop.

**On/Off Switch:** (on motor controller) Turn to "ON" position for wrapping.

**Speed Adjustment Knob:** (On motor controller) Rotate clockwise to increase turntable speed.



## SECTION 5. OPERATING INSTRUCTIONS (Continued)

### MODEL 150 & 175

**Note:** Hitting the “Emergency Stop” switch on the control panel cuts out all power to the unit and stops all movement. If the “Emergency Stop” is used, all control switches on the control panel must be placed in the “OFF” position prior to disengagement of the “Emergency Stop”

1. Place a loaded pallet on the turntable platform making sure that the load is centered. Make sure that there are no obstructions around or under the load.
2. Make sure that switches on the control panel are “OFF”. Turn the “ON/OFF” key to the “ON” position.
3. Move the film carriage to the desired starting point using the carriage “UP” and “DOWN” selector switch. Return the film carriage switch to the “OFF” position.
4. Place the loose end of the stretch wrap film onto the product, trapping the film so that it will not pull out.
5. Make sure all personnel are clear of the stretch wrap machine. Step back away from the turntable and off to the side of the unit by the control panel.

#### WARNING !

Operators must be alert to all personnel in the vicinity of the unit to avoid any surprises to these personnel in regard to movement of position of the unit at any time. Never operate the unit if you cannot see it or the personnel around it.

6. Turn the turntable control switch to the “ROTATE” position.
7. Use the carriage “UP” and “DOWN” selector switch to place the film in the desired starting location on the pallet.
8. The film carriage and turntable speeds can be adjusted by rotating their respective adjustment knobs. Film tension can be adjusted by rotating the knob on the top of the roll.
9. When the pallet has been fully wrapped, return the film carriage and turntable selector switches to the “OFF” position.
10. After the platform has stopped rotating, break the film midway between the product and attach film tail to product.
11. The pallet may now be removed from the platform.

#### CAUTION !

Exercise caution when removing the load from the unit. Make sure that the device that is being used to remove the load picks up only the load and pallet and not the turntable platform.

## SECTION 5. OPERATING INSTRUCTIONS (Continued)

### MODEL 150 & 175

#### CONTROL FUNCTIONS:

**Power – Key switch:** On/Off

**Platform Rotation Switch:** Off/Rotate

**Platform Speed Knob, 0 – 100%:** Rotate clockwise to increase platform speed.

**Film Direction Switch:**

**Up:** Up position moves film carriage up until upper limit switch is reached.

**Down:** Moves film carriage down until lower limit switch is reached.

**Off:** Carriage does not move

**Film Speed Knob:** 0 – 100%

**Emergency Stop:** Press to stop all machine functions.

## SECTION 6. MAINTENANCE INSTRUCTIONS

Read this manual carefully before attempting any maintenance on the stretch wrap machine.

### CAUTION !

Whenever inspecting the unit or performing maintenance on the unit, be sure to follow OSHA Tag out/Lockout requirements as a minimum precaution to prevent accidental movement of the unit by other personnel.

This unit does not require any weekly maintenance, aside from keeping the area around the unit free of loose debris.

**Semi-Annually** (or more frequently if required by heavy usage)

1. Once every six (6) months, the chain on the drive unit should be lubricated using any standard chain lubricant or a #2 amber grease.
2. Check the chain tension and adjust if needed.
3. Check all rollers, axles and bearings for wear and schedule replacement if warranted.
4. Do not let the equipment stay in disrepair; fix little problems while they are still little or some of them may become severe quickly.
5. On model 175's lightly lubricate the mechanical pre-stretch gears with any standard gear lubricant or a #2 amber grease.

## SECTION 7. ELECTRICAL DETAILS

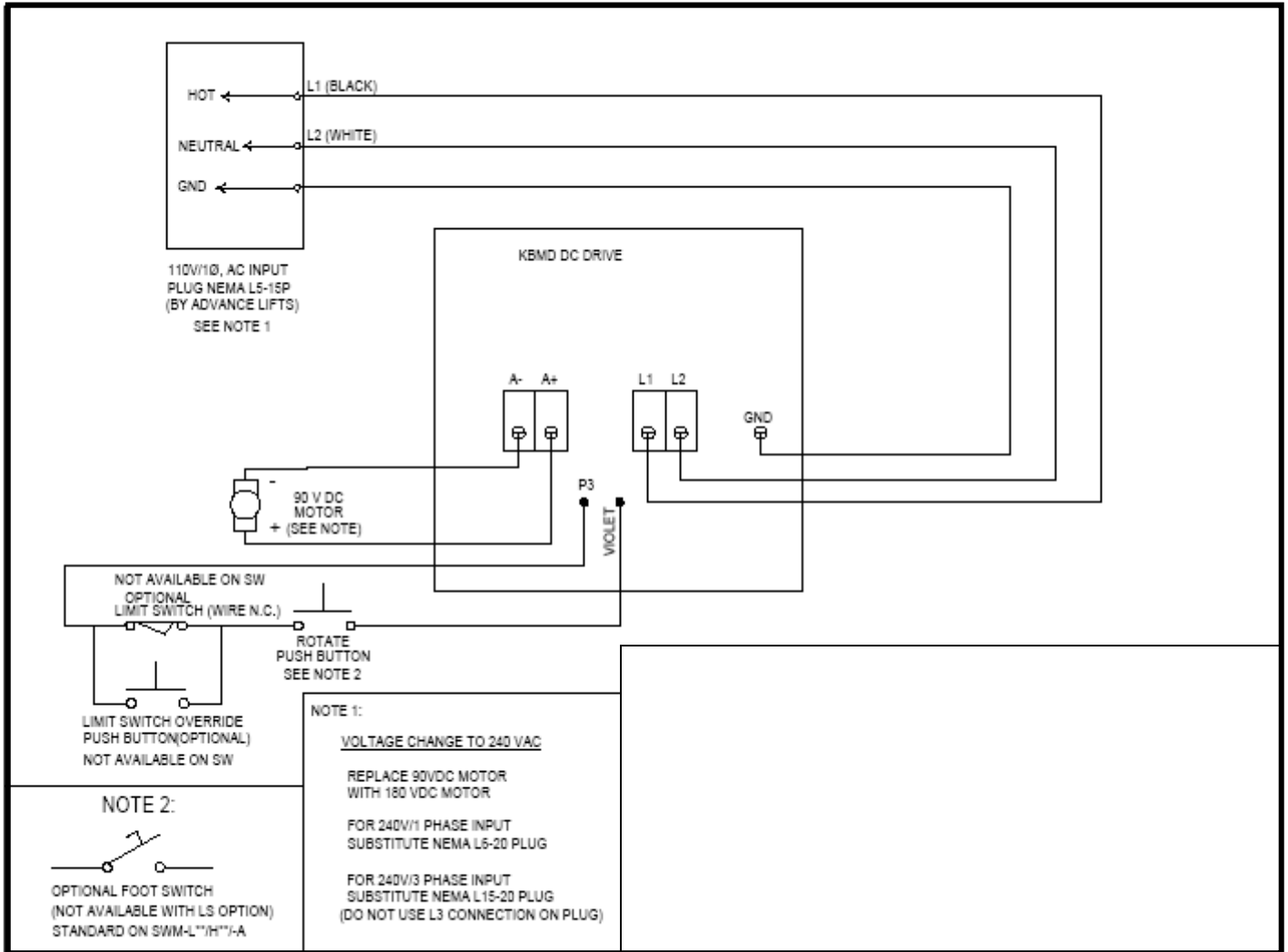

## SECTION 9. TROUBLESHOOTING

### A. Turntable does not rotate, motor will not run:

1. Check to make sure that unit is plugged into a working electrical receptacle.
2. Check control box fuse. Warning! Disconnect power before checking fuses. If fuse(s) are blown check for electrical short before replacing fuses or restoring power.

### B. Turntable or carriage will not move, but motor runs:

1. Chain on drive assembly is broken or off the sprockets. Chain coming off sprockets can damage gear(s) and/or gear reducer. Maintain proper chain tension as described in the maintenance section of this manual.
2. Defective or damaged gear reduction unit.
3. Turntable or load is obstructed.

### C. Equipment turns too slowly:

1. Foreign material may be lodged under the platform or in the drive mechanism.
2. The load may be rubbing against an adjacent obstruction.
3. Speed settings may be too low.
4. Load exceeding equipment ratings.

### D. Equipment does not turn the rated load:

1. Unit may be overloaded.
2. Platform may be shifted or damaged from transit and binding.
3. Foreign material may be lodged below platform or in drive mechanism.
4. Load may be hitting an adjacent obstruction.

### E. Film does not dispense properly or keeps breaking.

1. Film tension set too high.
2. Turntable speed too fast.
3. Film quality too low for pre-stretch capabilities, (175 Model only, see alternative film loading detail below).

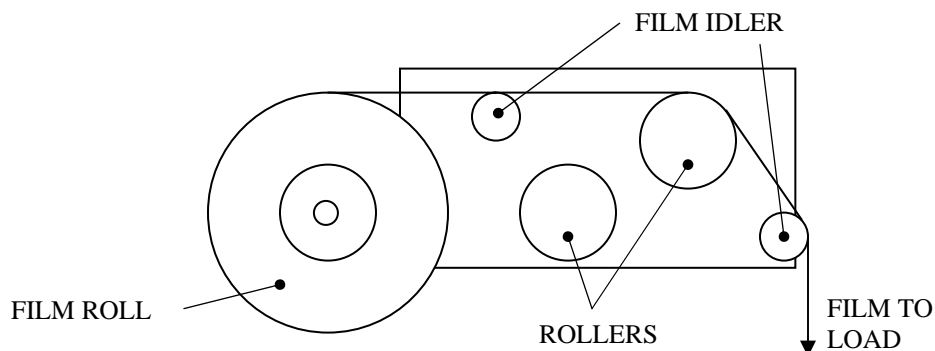

0% Pre-Stretch mode (Model 175 only)

## SECTION 10. WARRANTY

For a period of one year from date of shipment from the Company's plant, the Company agrees to replace or repair free of charge, any defective parts, material or workmanship on new equipment.

For an additional two years beyond the first year of warranty, the company shall replace or repair any parts returned to the Company freight prepaid, subject to factory inspection and determination of cause of failure. This warranty is not limited by the number of cycles, but does not include normal wear items such as chains, sprockets, belts, rollers & shafts.

For a period of five years from date of shipment from the Company's plant, the company agrees to repair or replace any defective structural component.

Company authorization must be obtained prior to commencement of any work. The Company reserves the right of final determination in all warranty considerations. Evidence of low supply voltage, overloading, abuse, neglect or field modification without written approval shall void this warranty. No contingent liabilities will be accepted.

Damage incurred in transport is the responsibility of the carrier and is not covered by this warranty. Any damage detected upon receipt of equipment should be immediately reported to the carrier. If you need assistance filing your claim please contact Advance Lifts.

## SECTION 11. PARTS LIST

<b>SW100H60/L40 &amp; SW125H60/L40</b>	<b>PART #</b>
<b>MECHANICAL:</b>	
TURNTABLE WHEEL	003-892
TURNTABLE WHEEL BOLT	004-067
TURNTABLE WHEEL NUT	004-065
TURNTABLE SPROCKET ASSEMBLY	035-132
<b>ELECTRICAL</b>	
DRIVE BOARD (KBMD240D)	002-900
TURNTABLE GEAR REDUCER (920MDN30R56)	015-211
MOTOR 115/1	003-580
MOTOR 230/3	003-579
<b>SSW150H60 &amp; SW175H60</b>	
<b>MECHANICAL:</b>	
TURNTABLE CASTER	015-724
TURNTABLE SPROCKET ASSEMBLY	035-132
<b>ELECTRICAL</b>	
TURNTABLE DRIVE MOTOR 115/1	003-580
TURNTABLE DRIVE MOTOR 230/3	003-579
TURNTABLE BOARD (KBMM225)	003-582
TURNTABLE GEAR REDUCER (920MDN30R56)	015-211
CARRIAGE GEAR REDUCER (920MDN50R56)	015-213
CARRIAGE MOTOR 115/1	001-393
CARRIAGE MOTOR 230/3	003-581
CARRIAGE DRIVE BOARD	015-349
LIMIT SWITCH	026-184
LIMIT SWITCH ARM	027-470
<b>SWL150L40 &amp; SW175L40</b>	
<b>MECHANICAL</b>	
TURNTABLE WHEEL	003-892
TURNTABLE WHEEL BOLT	004-067
TURNTABLE WHEEL NUT	004-065
TURNTABLE SPROCKET ASSEMBLY	035-132
<b>ELECTRICAL</b>	
TURNTABLE DRIVE MOTOR 115/1	003-580
TURNTABLE DRIVE MOTOR 230/3	003-579
TURNTABLE BOARD (KBMM225)	003-582
TURNTABLE GEAR REDUCER (920MDN30R56)	015-211
CARRIAGE GEAR REDUCER (920MDN50R56)	015-213
CARRIAGE MOTOR 115/1	001-393
CARRIAGE MOTOR 230/3	003-581
CARRIAGE DRIVE BOARD	015-349
LIMIT SWITCH	026-184
LIMIT SWITCH ARM	027-470



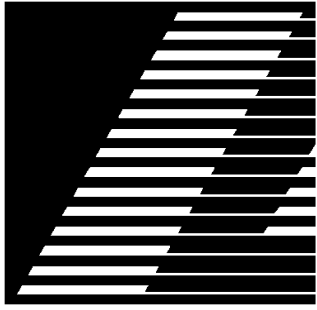

# **ADVANCE LIFTS**

---

## **300 AND 200 SERIES SEMI AUTOMATIC STRETCH WRAP MACHINES OWNERS MANUAL**



### **CAUTION!**

THIS MANUAL IS AN IMPORTANT DOCUMENT IT SHOULD BE KEPT WITH THE MACHINE OR LOCATED WHERE READILY AVAILABLE TO OPERATORS AND MAINTENANCE PERSONNEL FOR REFERENCE PURPOSES.





INSTALLATION, OPERATION AND MAINTENANCE MANUAL  
FOR THE FOLLOWING STRETCH WRAPPER MODEL NUMBERS

Throughout this manual, units are referred to by series. Each series has special installation, maintenance and safety requirements.

300 Series Stretch Wrappers (SW300L40 & SW300H60)

200 Series Stretch Wrappers (SW200L40 & SW200H60)

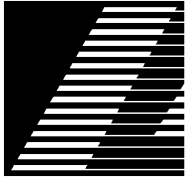

# ADVANCE LIFTS

---

## Stretch Wrapper Installation, Operation and Maintenance Manual

In any correspondence with your distributor or the factory you will need the following information:

Model Number \_\_\_\_\_ Serial Number \_\_\_\_\_

Installation location: \_\_\_\_\_  
\_\_\_\_\_  
\_\_\_\_\_

---

Distributor Information: \_\_\_\_\_  
\_\_\_\_\_  
\_\_\_\_\_  
\_\_\_\_\_

**Advance Lifts Inc.**  
**701 S. Kirk Road**  
**St. Charles, IL 60174-3428**  
**Toll Free 1-800-843-3625**  
**Sales Fax 1-630-584-9405**  
**Parts and Service Fax 1-630-584-6837**  
**E-mail: [Parts@advancelifts.com](mailto:Parts@advancelifts.com)**

\*Advance Lifts Inc. furnishes one manual with each unit. Additional manuals are available at \$25.00 each.

## SECTION 2 INDEX & INTRODUCTION

Identification.....	Section 1
Index & Introduction .....	Section 2
*Responsibilities of Owners/Users .....	Section 3
*Installation Instructions .....	Section 4
*Operating Instructions .....	Section 5
Film Selection	
*Maintenance Instructions .....	Section 6
Electrical Details .....	Section 7
Schematics	
Identification and Label Placement .....	Section 8
Troubleshooting Hints .....	Section 9
Warranty .....	Section 10
Glossary of Terms.....	Section 11
Parts Lists.....	Section 12

## INTRODUCTION

Congratulations, the equipment that you have purchased is of the highest quality. Your Advance Lifts Stretch Wrapper will provide you with many years of trouble free service in return for the minimal maintenance described in this manual.

Please be sure that no individual is allowed to operate the stretch wrapper until they have been fully familiarized with operating instructions in this manual. Also insure that at least one person at the stretch wrapper site is familiar with the maintenance section of this manual and is assigned responsibility for doing the maintenance on a regular basis.

Please note that the stretch wrapper has a metal nameplate attached to it that contains information such as the model number, capacities, and the serial number. Do not remove the nameplate. Be sure that load weight never exceeds the capacity shown on the nameplate or they may cause damage to the stretch wrapper or injure personnel. Also, be sure to have the serial number of the stretch wrapper handy if you have to call the factory. The serial number identifies your specific stretch wrapper and will allow factory personnel to give you the most thorough and timely assistance possible.

This manual is under constant review and we would appreciate any constructive suggestions that may enhance its usefulness. Please send your suggestions to Advance Lifts Inc Stretch Wrappers, Attn: Service Manager

Thank you for purchasing our product.

\*Mandatory reading before attempting installation.

## SECTION 3. RESPONSIBILITIES OF OWNERS & USERS

### **Owner responsibility: The owner shall be responsible for:**

1. Ensuring that the installation of the Advance Lifts Stretch Wrapper is in conformance with applicable local, state and federal codes and ordinances.
2. Providing a properly maintained stretch wrapper that meets all applicable safety standards.
3. Setting up and following a program of training and instructing employees in safe methods of work before assigning them to operate or maintain a stretch wrapper. The employer shall maintain records of this training to include the day(s) of the training and the content of the training received. The employer shall ensure, by adequate supervision, that correct operating and maintenance procedures are understood and followed. The employer should refer to the manufacturer's and installer's instructions for this purpose.
4. Operating the stretch wrapper in accordance with the design specifications as recommended by the manufacturer.
5. Repairing, prior to operation, all malfunctions or breakdowns that results in unsafe operating conditions of the stretch wrapper.
6. Specifically inspecting safety interlocks, switches and other protective devices, to ensure that these devices are not disabled or bypassed, and to not permit the stretch wrapper to be operated unless these devices are fully functional. These inspections will be in accordance with an established program of periodic and regular inspections that are recorded along with a complete history of all maintenance performed on the equipment.

### **User Responsibility: The User shall be responsible for:**

1. Using all applicable safety features provided on the stretch wrapper.
2. Operating, maintaining and using the stretch wrapper only after being properly instructed and trained in accordance with the instructions given in item # 3 above.
3. Immediately reporting any damage to or malfunction of the stretch wrapper to the employer or responsible authority.
4. Ensuring that all individuals are aware of and clear of the operation and pinch point areas before actuating the controls.
5. Not placing hands or fingers in or near moving portions of the machine during use.
6. Ensuring that all individuals are standing clear of the rotating load and moving carriage during the stretch wrapping operation.
7. Ensuring that no one disables or bypasses any safety interlocks, switches and other protective devices and that the stretch wrapper is not operated unless these devices are fully functional.

**Modifications or Alterations:** Modifications or alternations of industrial stretch wrappers shall be made only with written permission of the original manufacturer, Advance Lifts Stretch wrappers. These changes shall be in conformance with all applicable provisions of this standard and shall be as safe as the equipment was before modification. These changes shall also satisfy all safety recommendations of the original equipment manufacturer of the particular application of the stretch wrapper.

## SECTION 4. INSTALLATION INSTRUCTIONS

### Series 300 & 200 Stretch Wrap Machines

#### **Equipment and Supplies Required:**

1. Equipment to maneuver the Advance Stretch wrapper into position. All units are manufactured with forklift pockets for maneuvering.
2. An electrical fused disconnect (if required), wiring and fittings for the branch circuit and the appropriate receptacle. While not necessary, Advance Lifts recommends that this unit be connected to a dedicated circuit.

#### **Shipping and Packaging Warning:**

The stretch wrapper is shipped from the factory in one piece. No assembly is required. The unit comes with a pre-wired electrical system that is ready to plug in and is fully tested at the factory for ease of installation. However, if the installer does not carefully follow these installation instructions, it is possible to damage the equipment, so please read this entire procedure before proceeding with the installation.

#### **Equipment Location:**

1. The floor should be flat and level concrete that is strong enough to support the weight of the unit.
2. The equipment is suitable for indoor operation only.
3. Advance recommends a minimum of 3 feet clearance at the sides and behind the stretch wrapper. An area in the front or the side of the stretch wrapper must be obstruction free to accommodate the loading of pallets. The area around the controls of the unit must be kept clear in order to prevent tripping hazards during the loading and wrapping process.

#### **Unloading and Final Positioning:**

1. The preferred system of unloading is with a fork lift. Most stretch wrappers are shipped attached to a shipping pallet or skid. Remove the unit from the truck using the shipping skid. Once the unit is off the truck and safely on the floor, remove all the banding and straps holding the unit to the skid.
2. There are fork pockets located on all Advance stretch wrappers specifically for the purpose of lifting and moving the units. Forks should be spaced so as to slide into both fork pockets and should be inserted as far as possible. Care should be taken to prevent damage to the machine with the forks. Lift the stretch wrapper off the skid and place it in the final location.
3. After the unit is in position, clearance around the unit should be checked. A minimum of 3 feet is recommended.
4. Assure power outlet voltage is the same as the voltage identified on the machine. Depress E-Stop button and connect machine to electrical power.

## SECTION 5. OPERATING INSTRUCTIONS

### FILM LOADING

#### SERIES 200

This model is designed to use 20" wide industrial machine film with a 3" core. To load film, rotate the core retainer up, load film on stationary lower retainer then rotate the top retainer back into place to secure film. This unit utilizes a geared mechanical pre-stretch which must be loaded in accordance with the illustration below. Due to the nature of pre-stretch, heavier gauge films are recommended for use.

To Load Film (See figure below)

1. Place film roll on spindle. Lower the upper retaining spindle onto roll center. The delivery of film should come off in a clockwise fashion as viewed from above.
2. Unroll approximately 2 - 3 feet of film and form it into a rope with your hands.
3. Route the film through the rollers per the figure below. Once film is established in the rollers, it may be attached to the load.

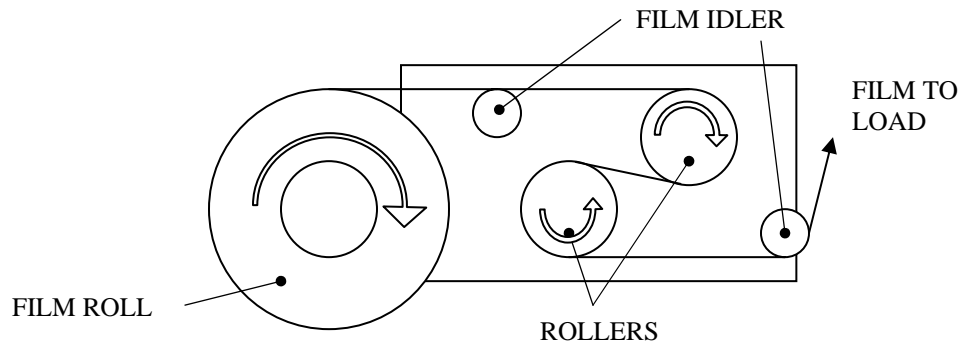

TOP VIEW OF FILM LOADING, SERIES 200 (ONLY)

## SECTION 5. OPERATING INSTRUCTIONS

### FILM LOADING

#### SERIES 300

This model is designed to use 20" wide industrial machine film with a 3" core. To load film, rotate the core retainer up, load film on stationary lower retainer then rotate the top retainer back into place to secure film. This unit utilizes a geared mechanical pre-stretch which must be loaded in accordance with the illustration below. Due to the nature of pre-stretch, higher quality films are recommended for use.

To Load Film (See figure below)

1. Place film roll on spindle. Lower the upper retaining spindle onto roll center. The delivery of film should come off in a clockwise fashion as viewed from above.
2. Open the "Quick Load" film door by depressing the thumb latch and pulling the door toward you.
3. Unroll approximately 2 - 3 feet of film and pull it between the door and the pre-stretch rollers. Close the "Quick Load" film door and be certain the latch engages firmly by pulling back on the door.
4. The film can then be pulled through the pre-stretch and secured to the load for wrapping. (machine power must be on to power feed the film)

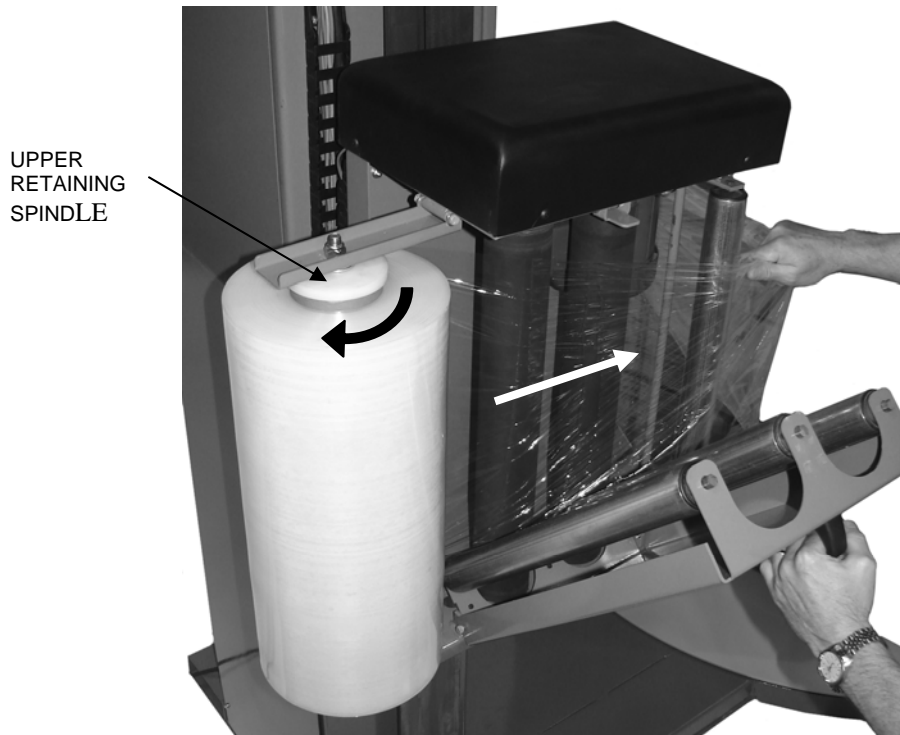

## SECTION 5. OPERATION INSTRUCTIONS

### CONTROL PANEL - CONTROL FUNCTIONS

#### **SERIES 300 & 200**

**Wrap Mode Selector Switch:** Used to select one (1) of the two (2) wrapping modes

1. UP/DOWN Mode starts at the bottom of the load (home position) The Load is wrapped from the bottom to the top and is then wrapped from the top to the bottom. The film carriage and the turntable return to the “home” position at the end of the wrap cycle.
2. Up Mode starts at the bottom of the load (home position) the load is wrapped from the bottom to the top only. The carriage and turntable return to the home position (down) without wrapping on the way.

#### **Banding Pushbutton (momentary contact)**

Used to add extra wraps of film at various locations on the load between the top and bottom of the load during the wrapping cycle. Depress the button as many times as there are additional wraps needed when the film carriage is at the desired location (press button once = one revolution, twice = two revolutions, etc). Each time the button is pressed one additional wrap is placed at that carriage location. Once banding is complete the auto cycle will continue.

#### **Photo Eye Switch On/Off**

Turns the photo eye to on or off. When in the “ON” position the photo eye (located on the film carriage) will automatically locate the top of the load during a wrap cycle. Wrap overlap may be adjusted by changing the angle of the photo eye (aiming the photo eye upward will cause the carriage to stop short of the top of load, aiming down will cause the carriage to overshoot the top of load, see photo on page 5-5). When in the “OFF” position the top of the load is not sensed by the photo eye. The upper limit of the film carriage travel is determined by the position of the manual carriage limit (located on the column).

#### **Carriage Jog Switch**

Used to manually move the film carriage up or down for maintenance or film loading. It is not intended for manual operation. When “DOWN” is selected the carriage will move down until it engages the lower carriage stop. When “UP” is selected the carriage will move up until the upper carriage stop is engaged,

NOTE: Once the carriage has engaged the upper or lower stops, carriage travel will cease until the stop override is engaged. The band pushbutton serves as the override button in this case. Depress the “BANDING” button and select “UP” or “DOWN” to cause the carriage to move off the stops. **Caution!** Do not cause the carriage to over travel the limits at the top or bottom of travel.



## SECTION 5. OPERATION INSTRUCTIONS (CONTINUED)

### CONTROL PANEL - CONTROL FUNCTIONS

#### **Turntable Jog**

Used to manually rotate the turntable when not in automatic cycle mode. The turntable will rotate when the pushbutton is depressed.

#### **Start/Pause Pushbutton**

This pushbutton is used to start or pause the semiautomatic wrap cycle. Momentarily depress the "START/PAUSE" button to initiate wrapping. Wrapping will proceed to completion without any further input from the pushbutton. At any point during the cycle depressing the "START/PAUSE" pushbutton will cause the wrap cycle to pause. All motion of the turntable, carriage and power pre-stretch will cease until the "START/PAUSE" pushbutton is depressed again. The cycle will then resume from the point which it left off when the cycle pause was initiated. In the event of a film break (or the film roll runs out) the wrap process will automatically pause. To restart the cycle, reattach the film to the load and then depress the start/pause pushbutton. The cycle will resume wrapping at the point which it left off.

#### **Top Wraps Selector Switch (1-2-3)**

This switch is used to determine the total number of film wraps that will be applied at the top of the load. Increasing the number of wraps at the top of the load improves load retention. Rotate switch to select the desired number of wraps at the load top. Set this switch prior to starting a wrap cycle.

#### **Bottom Wraps Selector Switch (1-2-3)**

This switch is used to determine the number of film wraps that will be applied at the bottom of the load. Increasing the number of wraps at the bottom of the load improves load retention. Rotate this switch to select the desired total number of wraps at the load bottom. Set this switch prior to starting a wrap cycle.

#### **Film Tension Adjustment Knob (SW300 Only) (Low to High)**

This knob is used to adjust the amount of film tension as it is applied to the load. Film tension is measured between the carriage and the load. Rotate the knob to the desired film tension. Increasing film tension improves load retention. Use higher tension settings for heavy and unstable loads. Use low settings for lighter and/or fragile loads. It is recommended that the minimum tension setting needed to properly secure the load be used. Over time film force on the wrapped load increases as the film slowly tries to partially return to its original un-stretched length (called "film memory"). If a light or fragile load is wrapped with excessive film tension, crushing of the load may occur during product shipment.

## SECTION 5. OPERATION INSTRUCTIONS (CONTINUED)

### CONTROL PANEL - CONTROL FUNCTIONS

#### **Carriage Speed Adjustment Knob (Low to High)**

This knob is used to adjust the speed of the film carriage as it travels up and down the column upright. The speed of the carriage determines the amount of film overlap that is produced during a wrap cycle. Film overlap improves load retention. Increasing film overlap increases load retention. "HIGH" settings decrease overlap. "LOW" settings increase film overlap, but consume more film.

#### **Turntable Speed Adjustment Knob (Low to High)**

This knob determines the speed that the turntable rotates.

#### **Emergency Stop Button**

This button is used to quickly stop all power driven functions of the stretch wrapper in order to prevent personal injury or damage. To engage the emergency stop button, depress it inward. Once depressed the button will remain in the engaged position. Electrical power to the stretch wrapper controls and motor drives is interrupted while the emergency stop is engaged. When it is safe to restart the machine the emergency stop may be disengaged by rotating it counterclockwise until it pops out. If the emergency stop was engaged during a wrap cycle all information related to the cycle is lost. The turntable and film carriage must be returned to the starting position using their respective jog controls and a new wrap cycle may be initiated. For this reason, it is not appropriate to use the emergency stop button as a cycle pause.



**PHOTO EYE**

## SECTION 5. OPERATION INSTRUCTIONS (CONTINUED)

### WRAPPING LOADS

#### **SERIES 300 & 200**

1. Place a loaded pallet on the turntable platform making sure that the load is centered. Make sure that there are no obstructions around or under the load.
2. Make sure that the emergency stop button is engaged.
3. Draw the film through the pre-stretch as outlined on page 5-1 & 5-2 and attach it to the load or pallet.
4. Make sure all personnel are clear of the stretch wrap machine. Step back away from the turntable and off to the side of the unit by the control panel.

#### WARNING !

Operators must be alert to all personnel in the vicinity of the unit to avoid any surprises to these personnel in regard to movement of position of the unit at any time. Never operate the unit if you cannot see it or the personnel around it.

5. Using the selector switches, select the number of top and bottom wraps, set the carriage and turntable speeds to your desired settings. Start with speed settings set to low and adjust as needed during a wrap cycle. **Note:** speeds can be adjusted during a cycle but the number of wraps can only be adjusted before the cycle begins.
6. Press the START/PAUSE to begin the wrapping cycle. At any time during the auto cycle you may pause all functions by pressing the button again. Your preset parameters will not be lost.
7. When the pallet has been fully wrapped, the film carriage will be in the fully lowered position (or stop limit, which ever is activated first) and the turntable will rotate to a stop in the home position.
8. After the platform has stopped rotating, break the film midway between the products and attach the film tail to the product.
9. The pallet may now be removed from the platform.

#### CAUTION !

Exercise caution when removing the load from the unit. Make sure that the device that is being used to remove the load picks up only the load and pallet and not the turntable platform.

## SECTION 5. OPERATION INSTRUCTIONS (CONTINUED)

### FILM SLECTION

#### **NOTES ON FILM**

The SW300 and SW200 stretch wrappers are designed to utilize commonly available machine type stretch film with a 20" width and 3" center core diameter. The proper grade and thickness of film used is dependent upon the wrapping application. There are two general quality and price levels of stretch film: generic and high performance.

Generic film tends to be lower cost and lower performance. Generic films can be purchased from a variety of sources and the company of their manufacture is usually unknown. With this type of film there is no consistency of quality or performance from one order to the next. Generic type film should only be used on machines with 200% pre-stretch or less. Attempting to pre-stretch this type of film more than 200% could result in an excessive amount of film breakage and lost productivity.

High performance films are best suited to machines with high levels of pre-stretch (200%-300%). These films are usually multilayered cast type and their company of manufacture can usually be identified. Quality is very consistent from batch to batch. High performance films are designed so that they are easily pre-stretched to high levels, and thus do not develop the full strength until fully pre-stretched. This type of film should only be used in machines with 200% pre-stretch or greater. In addition, highest film economy is reached at higher levels of pre-stretch.

## SECTION 6. MAINTENANCE INSTRUCTIONS

### **SERIES 300 & 200**

Read this manual carefully before attempting any maintenance on the stretch wrap machine.

#### CAUTION !

Whenever inspecting the unit or performing maintenance on the unit, be sure to follow OSHA Tag out/Lockout requirements as a minimum precaution to prevent accidental movement of the unit by other personnel.

This unit does not require any weekly maintenance, aside from keeping the area around the unit free of loose debris.

#### **Daily: Visually inspect the following**

1. All electrical cords for damage or signs of wear.
2. Pre-stretch carriage belt for signs of wear or damage.

#### **Semi-Annually** (or more frequently if required by heavy usage)

1. Once every six (6) months, the chain on the drive unit should be lubricated using any standard chain lubricant or a #2 amber grease.
2. Check the chain tension and adjust if needed.
3. Check all rollers, axles and bearings for signs of wear and schedule replacement if warranted.
4. Do not let the equipment stay in disrepair; fix little problems while they are still little or some of them may become severe quickly.
5. Lightly lubricate the mechanical pre-stretch gears with any standard gear lubricant or a #2 amber grease.

#### **Annually:**

##### **Drive chain adjustment, (H60 Only)**

1. Remove the three (3) platform retaining bolts. Do not remove the center kingpin bolt.
2. Using suitable lifting device, remove platform. Loosen the four (4) ear reducer mounting plate retaining bolts.
3. Adjust chain tension by rotating adjustment bolt until correct chain tension is achieved (chain should deflect approximately .25" when 15 pounds of force is applied at the center of open span).
4. Tighten retaining bolts, check tension again and adjust if necessary.
5. Replace the platform and retaining bolts.
6. Connect power and verify correct turntable operation before using machine.

## SECTION 8. IDENTIFICATION AND LABEL PLACEMENT

**SW200/300 OPERATING INSTRUCTIONS**  
**READ AND UNDERSTAND OPERATING MANUAL**  
**PRIOR TO OPERATION.**

**WRAPPING LOADS (SEMI-AUTOMATIC)**

1. Center load on platform.
2. Clear all obstructions from turntable area.
3. Draw the film through the pre-stretch and attach it to the load.
4. Make sure the emergency stop button is not engaged.
5. Make sure all personnel are clear of the stretch wrap machine.
6. Set wrap parameters on control panel.
7. Press the **START/PAUSE** button to begin the wrapping cycle.
8. If desired the cycle can be paused by depressing the **START/PAUSE** button. Restart the cycle by depressing the button.
9. The turntable and carriage will return to their home positions at the end of the cycle.
10. After the platform has stopped rotating, break the film and attach the film tail to the product.
11. Remove the load from the platform.

**MANUAL OPERATION OF CARRIAGE AND TURNTABLE**

Depress the **TURNTABLE JOG** pushbutton to rotate the turntable manually. Release the pushbutton to stop. Return the turntable to home position prior to wrapping.

Rotate the **CARRIAGE JOG** switch to manually move the film carriage up or down. Release the switch to stop motion. Return the carriage to the fully lowered position prior to wrapping.

**NOTE:** Once the carriage has engaged the upper or lower stops, carriage travel will cease until the stop override is engaged. The band pushbutton serves as the override button in this case. Depress the "BANDING" button and select "UP" or "DOWN" to cause the carriage to move off the stops. **Caution!** Do not cause the carriage to over travel the limits at the top or bottom of travel.

Operating instructions located above control panel.

## SECTION 8. IDENTIFICATION AND LABEL PLACEMENT

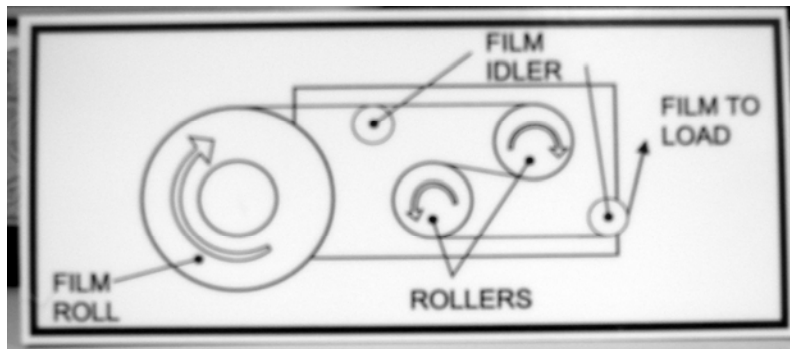

200 Series only, film loading instructions. Located on top of film prestretch carriage.



Danger sticker located on prestretch carriage warning of moving gears.

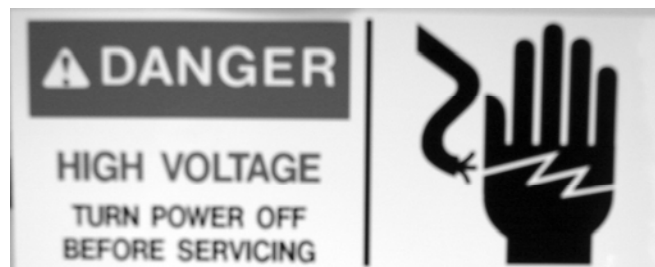

Danger sticker located on back panel warning of high voltage.



Cautionary sticker located on base frame of unit warning of moving equipment.

## SECTION 9. TROUBLESHOOTING

### All Models:

#### FILM BREAKS DURING WRAPPING

1. Quality of film inadequate for pre-stretch applications. Replace film with higher quality film, (see page 5-5 "film notes").
2. Film damaged. Check film roll for nicks, cuts or scrapes. Damaged film will easily break during pre-stretch.
3. Load has sharp protrusions that puncture film and cause breakage.

#### AUTO CYCLE WILL NOT START WHEN "START/PAUSE" PRESSED

1. Unit not connected to power source.
2. Emergency stop button pressed.
3. "Quick Load" film door open (series 300 only).
4. Turntable speed set to 0%.

#### TURNTABLE WILL NOT RETURN TO HOME POSITION

1. Faulty "home" position sensor. Consult factory
2. Physical restriction on load or turntable.

#### FILM BREAKS AT START OF CYCLE

1. Quality of film inadequate for pre-stretch applications. Replace film with higher quality film, (see page 5-5 "film notes").
2. Film damaged. Check film roll for nicks, cuts or scrapes. Damaged film will easily break during pre-stretch.
3. Load has sharp protrusions that puncture film and cause breakage.
4. Turntable speed set too high for film quality.
5. Film tension set too high for film quality.

#### CARRIAGE DOES NOT STOP AT TOP OF LOAD

1. Photo eye defective.
2. Photo eye not adjusted correctly. (See page 5-3)
3. Load color is too dark. Photo eye can not sense a black load, use manual stops.
4. Load too reflective. Use manual stops.
5. Manual height stop set too low. Raise manual height stop above load and repeat cycle.

#### CARRIAGE WILL NOT GO UP OR DOWN WITH JOG SWITCH

1. No power to equipment or emergency stop disengaged.
2. Carriage assembly came into contact with either the upper or lower limit switch during manual operation. As a safety measure the "BANDING" button must be depressed to override this safety function and continue operation.



## SECTION 9. TROUBLESHOOTING (CONTINUED)

### TURNTABLE WILL NOT TURN (“JOG” OR “AUTO CYCLE”)

1. No power to equipment.
2. Emergency stop button engaged.
3. Speed setting set too low.
4. Platform being physically restricted by an obstruction.
5. Drive motor failure.
6. Drive chain failure.

### TURNTABLE WILL NOT RETURN TO “HOME” POSITION.

1. Turntable position sensor failure.
2. System calibration failure, consult factory.

### FILM WILL NOT POWER FEED DURING FILM ATTACHMENT

1. No power to equipment.
2. “Quick Load” film door open.
3. Film loaded incorrectly.
4. Film dancer sensor failure.

### FILM WILL NOT POWER FEED DURING AUTO CYCLE

1. “Quick Load” film door not closed fully.

### FILM BREAKS DURING WRAPPING CYCLE

1. Quality of film too low for pre-stretch.
2. Film damaged or punctured. Even small imperfections in film can cause breakage during pre-stretch.
3. Turntable speed too high for film quality.
4. Load has sharp protrusion that punctures film.

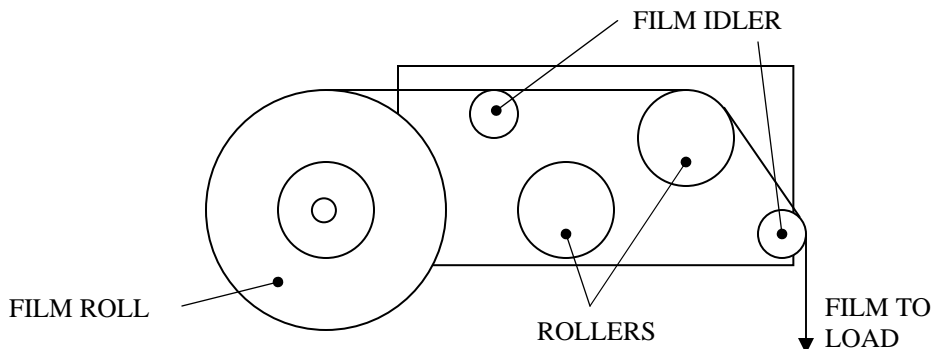

0% Pre-Stretch mode (Model 200 only)

## SECTION 10. WARRANTY

For a period of one year from date of shipment from the company's plant, the company agrees to replace or repair free of charge, any defective parts, material or workmanship on new equipment.

For an additional two years beyond the first year of warranty, the company shall replace or repair any parts returned to the Company freight prepaid, subject to factory inspection and determination of cause of failure. This warranty is not limited by the number of cycles, but does not include normal wear items such as chains, sprockets, belts, rollers & shafts.

For a period of five years from date of shipment from the Company's plant, the company agrees to repair or replace any defective structural component.

Company authorization must be obtained prior to commencement of any work. The Company reserves the right of final determination in all warranty considerations. Evidence of low supply voltage, overloading, abuse, neglect or field modification without written approval shall void this warranty. No contingent liabilities will be accepted.

Damage incurred in transport is the responsibility of the carrier and is not covered by this warranty. Any damage detected upon receipt of equipment should be immediately reported to the carrier. If you need assistance filing your claim please contact Advance Lifts.

## SECTION 11. GLOSSARY OF TERMS

### **Banding**

Putting multiple wraps of stretch film to certain areas of a load in order to reinforce the load.

### **Bottom Wraps**

The number of revolutions of stretch film that are applied to the bottom of a load.

### **Brake Roller**

A roller on a film delivery system that creates tension in the film as it is applied to the load.

### **Film Dancer**

A pivoting roller that measures the required film feed out in a pre-stretch system. The dancer provides feedback to the control system in order to compensate for the varied feed rate demand caused by the load corners and thus maintain constant film tension during wrapping.

### **Film Force to Load**

Also known as “film tension” or “film force”. The tensile force of the stretch film as it is applied to the pallet being wrapped (measured in pounds between the load and film carriage).

### **Home Position**

Position of the turntable and film carriage where the machine is ready to start a new wrap cycle.

### **Overlap**

The amount that a stretch wrap layer covers the previous layer on a wrapped load. Overlap improves load retention and can be changed by adjusting carriage speed.

### **Overwrap**

The amount that the stretch film is applied above the top of a wrapped load. Overwrap improves load retention and can be changed by adjustment of the load sensing photo eye.

### **Pre-stretch**

The process of stretching film prior to application of the film to the load. As the film passes through the pre-stretch carriage it is directed around the two rubber covered rollers which are rotating at different speeds. Because of the speed differential, the film is forced to stretch between the rollers.

### **Pre-stretch Carriage**

The part of a stretch wrapper that performs the film pre-stretching prior to application to the load. The carriage travels up and down vertically and wraps the film onto the load in a spiral pattern.

## SECTION 11. GLOSSARY OF TERMS

### **Pre-stretch Ratio**

A measure of how much a film is elongated by the pre-stretch process. Pre-stretch ratio is defined as a percentage change in film length. For example, a pre-stretch ratio of 200 signifies a change in length of +200%. The film length in this case is three times the length it was prior to stretching.

### **Top Wraps**

The number of revolutions of stretch film that are applied to the top of a load.

### **Wrap Parameters**

The variable settings that can be adjusted on a stretch wrapper in order to accommodate the load retention requirements of different loads. Typical parameters are bottom wraps, top wraps, carriage vertical speed (effects film overlap), turntable speed (effects wrapping speed), photo eye (effects film over wrap), and film force (effects load retention).

## SECTION 12. PARTS LISTS

### SW200L40

---

#### MECHANICAL

---

TURNTABLE ROLLER	A-12796
TURNTABLE PIN	035-136
SPROCKET ASSEMBLY	035-132

---

#### ELECTRICAL

---

DRIVE MOTOR	024-853
PROXIMITY SENSOR	015-352
SIEMENS PLC	038-377
CONTROL PANEL	A-12811
PHOTO EYE	038-265

### SW300H60

---

#### MECHANICAL

---

TURNTABLE CASTER	015-724
TURNTABLE SPROCKET ASSEMBLY	035-132

---

#### ELECTRICAL

---

DRIVE & PRE-STRETCH MOTOR	024-853
SIEMENS PROXIMITY SENSOR	015-352
SIEMENS PLC	034-809
TURCK PROXIMITY SENSOR	037-052
CONTROL PANEL	A-12811
PHOTO EYE	038-265
PRE-STRETCH DANCER SPRING	A-13682
PRE-STRETCH POSITION SENSOR	038-043
KB ELECTRONICS 5K POT	002-553

### SW200L40

---

#### MECHANICAL

---

TURNTABLE ROLLER	A-12796
TURNTABLE PIN	035-136
SPROCKET ASSEMBLY	035-132

---

#### ELECTRICAL

---

DRIVE & PRE-STRETCH MOTOR	024-853
SIEMENS PROXIMITY SENSOR	015-352
SIEMENS PLC	034-809
TURCK PROXIMITY SENSOR	037-052
CONTROL PANEL	A-12811
PHOTO EYE	038-265
PRE-STRETCH DANCER SPRING	A-13682
PRE-STRETCH POSITION SENSOR	038-043
KB ELECTRONICS 5KPOT	002-553

