

NC-1 Spray Gun Driver

Customer Product Manual

Part 1101142-03

Issued 11/18

For parts and technical support, call the Industrial Coating Systems Customer Support Center at (800) 433-9319 or contact your local Nordson representative.

This document is subject to change without notice.
Check <http://emanuals.nordson.com> for the latest version.



NORDSON CORPORATION • AMHERST, OHIO • USA

Table of Contents

Safety	1	Installation	6
Qualified Personnel	1	Conditions of Warranty	6
Intended Use	1	Factory Settings for NC-1 Driver	6
Regulations and Approvals	1	Driver and Interface Boards	9
Personal Safety	2	Driver Mounting	11
High-Pressure Fluids	2	Input and Output Connections	12
Fire Safety	3	System Wiring	13
Halogenated Hydrocarbon Solvent Hazards ..	4	Driver Signal List	13
Action in the Event of a Malfunction	4	Interface Signal List	14
Disposal	4	Operation	15
Description	5	Power Switch	15
NC-1 Driver Requirements	5	LED Indicators	15
EMC Directive Compliance	6	Parts	15

Contact Us

Nordson Corporation welcomes requests for information, comments, and inquiries about its products. General information about Nordson can be found on the Internet using the following address:
<http://www.nordson.com>.

Address all correspondence to:

Nordson Corporation
Attn: Customer Service
555 Jackson Street
Amherst, OH 44001

Notice

This is a Nordson Corporation publication which is protected by copyright. Original copyright date 2010. No part of this document may be photocopied, reproduced, or translated to another language without the prior written consent of Nordson Corporation. The information contained in this publication is subject to change without notice.

Trademarks

CleanSpray, MEG, iTRAX, Nordson, and the Nordson logo are registered trademarks of Nordson Corporation.

NC-1 Spray Gun Driver

Safety

Read and follow these safety instructions. Task- and equipment-specific warnings, cautions, and instructions are included in equipment documentation where appropriate.

Make sure all equipment documentation, including these instructions, is accessible to persons operating or servicing equipment.

Qualified Personnel

Equipment owners are responsible for making sure that Nordson equipment is installed, operated, and serviced by qualified personnel. Qualified personnel are those employees or contractors who are trained to safely perform their assigned tasks. They are familiar with all relevant safety rules and regulations and are physically capable of performing their assigned tasks.

Intended Use

Use of Nordson equipment in ways other than those described in the documentation supplied with the equipment may result in injury to persons or damage to property.

Some examples of unintended use of equipment include

- using incompatible materials
- making unauthorized modifications
- removing or bypassing safety guards or interlocks
- using incompatible or damaged parts
- using unapproved auxiliary equipment
- operating equipment in excess of maximum ratings

Regulations and Approvals

Make sure all equipment is rated and approved for the environment in which it is used. Any approvals obtained for Nordson equipment will be voided if instructions for installation, operation, and service are not followed.

Personal Safety

To prevent injury follow these instructions.

- Do not operate or service equipment unless you are qualified.
- Do not operate equipment unless safety guards, doors, or covers are intact and automatic interlocks are operating properly. Do not bypass or disarm any safety devices.
- Keep clear of moving equipment. Before adjusting or servicing moving equipment, shut off the power supply and wait until the equipment comes to a complete stop. Lock out power and secure the equipment to prevent unexpected movement.
- Relieve (bleed off) hydraulic and pneumatic pressure before adjusting or servicing pressurized systems or components. Disconnect, lock out, and tag switches before servicing electrical equipment.
- While operating manual spray guns, make sure you are grounded. Wear electrically conductive gloves or a grounding strap connected to the gun handle or other true earth ground. Do not wear or carry metallic objects such as jewelry or tools.
- If you receive even a slight electrical shock, shut down all electrical or electrostatic equipment immediately. Do not restart the equipment until the problem has been identified and corrected.
- Obtain and read Material Safety Data Sheets (MSDS) for all materials used. Follow the manufacturer's instructions for safe handling and use of materials, and use recommended personal protection devices.
- Make sure the spray area is adequately ventilated.
- To prevent injury, be aware of less-obvious dangers in the workplace that often cannot be completely eliminated, such as hot surfaces, sharp edges, energized electrical circuits, and moving parts that cannot be enclosed or otherwise guarded for practical reasons.

High-Pressure Fluids

High-pressure fluids, unless they are safely contained, are extremely hazardous. Always relieve fluid pressure before adjusting or servicing high pressure equipment. A jet of high-pressure fluid can cut like a knife and cause serious bodily injury, amputation, or death. Fluids penetrating the skin can also cause toxic poisoning.

If you suffer a fluid injection injury, seek medical care immediately. If possible, provide a copy of the MSDS for the injected fluid to the health care provider.

The National Spray Equipment Manufacturers Association has created a wallet card that you should carry when you are operating high-pressure spray equipment. These cards are supplied with your equipment. The following is the text of this card:



WARNING: Any injury caused by high pressure liquid can be serious. If you are injured or even suspect an injury:

- Go to an emergency room immediately.
- Tell the doctor that you suspect an injection injury.
- Show him this card
- Tell him what kind of material you were spraying

MEDICAL ALERT—AIRLESS SPRAY WOUNDS: NOTE TO PHYSICIAN

Injection in the skin is a serious traumatic injury. It is important to treat the injury surgically as soon as possible. Do not delay treatment to research toxicity. Toxicity is a concern with some exotic coatings injected directly into the bloodstream.

Consultation with a plastic surgeon or a reconstructive hand surgeon may be advisable.

The seriousness of the wound depends on where the injury is on the body, whether the substance hit something on its way in and deflected causing more damage, and many other variables including skin microflora residing in the paint or gun which are blasted into the wound. If the injected paint contains acrylic latex and titanium dioxide that damage the tissue's resistance to infection, bacterial growth will flourish. The treatment that doctors recommend for an injection injury to the hand includes immediate decompression of the closed vascular compartments of the hand to release the underlying tissue distended by the injected paint, judicious wound debridement, and immediate antibiotic treatment.

Fire Safety

To avoid a fire or explosion, follow these instructions.

- Ground all conductive equipment. Use only grounded air and fluid hoses. Check equipment and workpiece grounding devices regularly. Resistance to ground must not exceed one megohm.
- Shut down all equipment immediately if you notice static sparking or arcing. Do not restart the equipment until the cause has been identified and corrected.
- Do not smoke, weld, grind, or use open flames where flammable materials are being used or stored.
- Do not heat materials to temperatures above those recommended by the manufacturer. Make sure heat monitoring and limiting devices are working properly.

Fire Safety (contd)

- Provide adequate ventilation to prevent dangerous concentrations of volatile particles or vapors. Refer to local codes or your material MSDS for guidance.
- Do not disconnect live electrical circuits when working with flammable materials. Shut off power at a disconnect switch first to prevent sparking.
- Know where emergency stop buttons, shutoff valves, and fire extinguishers are located. If a fire starts in a spray booth, immediately shut off the spray system and exhaust fans.
- Shut off electrostatic power and ground the charging system before adjusting, cleaning, or repairing electrostatic equipment.
- Clean, maintain, test, and repair equipment according to the instructions in your equipment documentation.
- Use only replacement parts that are designed for use with original equipment. Contact your Nordson representative for parts information and advice.

Halogenated Hydrocarbon Solvent Hazards

Do not use halogenated hydrocarbon solvents in a pressurized system that contains aluminum components. Under pressure, these solvents can react with aluminum and explode, causing injury, death, or property damage. Halogenated hydrocarbon solvents contain one or more of the following elements:

<u>Element</u>	<u>Symbol</u>	<u>Prefix</u>
Fluorine	F	“Fluoro-”
Chlorine	Cl	“Chloro-”
Bromine	Br	“Bromo-”
Iodine	I	“Iodo-”

Check your material MSDS or contact your material supplier for more information. If you must use halogenated hydrocarbon solvents, contact your Nordson representative for information about compatible Nordson components.

Action in the Event of a Malfunction

If a system or any equipment in a system malfunctions, shut off the system immediately and perform the following steps:

- Disconnect and lock out system electrical power. Close hydraulic and pneumatic shutoff valves and relieve pressures.
- Identify the reason for the malfunction and correct it before restarting the system.

Disposal

Dispose of equipment and materials used in operation and servicing according to local codes.

Description

The Nordson NC-1 Spray Gun Driver provides gun drive functions for one Nordson spray gun. The NC-1 is designed to interface with a user-supplied timing device and requires a 24 Vdc power source.

This manual covers driver installation, configuration, and parts. The driver is shipped with two #10 mounting screws and a spare 2.5 amp fuse.

Weight: 1.352 kg (2.98 lbs)

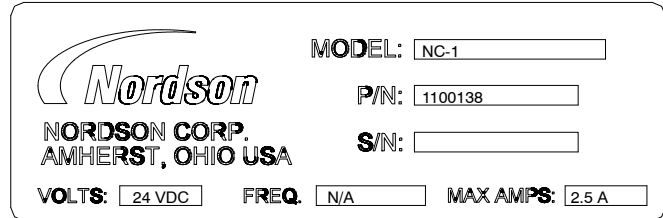
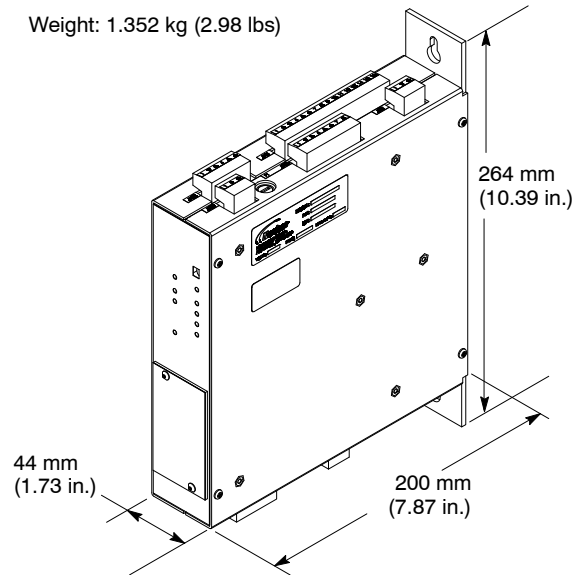

Figure 1 NC-1 Spray Gun Driver

NC-1 Driver Requirements

NOTE: For compliance with the European Union Electromagnetic Compatibility Directive, refer to *EMC Directive Compliance* on page 6.

The following customer-supplied hardware is required to install the NC-1:

- Power Supply: 24 Vdc, 2.5 amp required per NC-1
- Enclosure: IP54 or better metal enclosure
- Cable, as required, for spray trigger inputs, reset input, and alarm outputs

EMC Directive Compliance

Refer to Figure 1 or the equipment label for electrical requirements.

For compliance to the European Union Electromagnetic Compatibility Directive (EMC Directive):

1. Mount the NC-1 driver in an IP54 or better metal enclosure.
2. Use CE-labeled power supply (SOLA SDN 10-24-100P or equivalent).
3. For general safety fuse L1 and L2.
4. All customer-supplied cables must be shielded and terminated.

Installation



WARNING: Allow only qualified personnel to perform the following tasks. Follow the safety instructions in this document and all other related documentation. All installations must conform to national and local codes.

Installation of the NC-1 driver consists of configuration, mounting, and electrical connections.

NOTE: For compliance with the European Union Electromagnetic Compatibility Directive, refer to *EMC Directive Compliance*.

Conditions of Warranty

The NC-1 driver must be installed and wired according to the specifications provided herein. Other than technical support provided under warranty for defective equipment, Nordson will not provide complimentary post-sale technical support if the installation does not comply with the requirements stated in this manual and local electrical codes.

Furthermore, if post-sale technical services are performed and the installation is found to be non-compliant with these requirements, then the customer will be invoiced and will be responsible for payment of the charges associated with the service.

Factory Settings for NC-1 Driver



CAUTION: Electrostatic sensitive device: To avoid damaging the circuit board wear an ESD wriststrap and use proper grounding techniques.

See Figure 2 and Table 1. At the factory, the following settings are made:

- the JP6 jumper is installed over pins 2 and 3 (MASTER). Pin 1 will be closest to the edge of the PC board, with the access plate removed. If not set to Master, the 4 green LEDs of the interface board will flash and the driver will not operate.
- The address switches are set to “0 0 0”. If set to any other address, the top 3 LEDs of the interface board will flash and the driver will not operate.

If on installation the driver does not operate and the either group of LEDs is flashing, set the jumper and address switches to the factory settings:

1. Using a screw driver, remove the access plate on the front of the NC-1 driver.
2. Make sure pins 2 and 3 on JP6 are jumpered. When you are looking through the access hole, above the address switches, you are seeing JP6 from the side with pin 1 closest to the edge of the PC board.
3. Make sure all three address switches are set to "0".

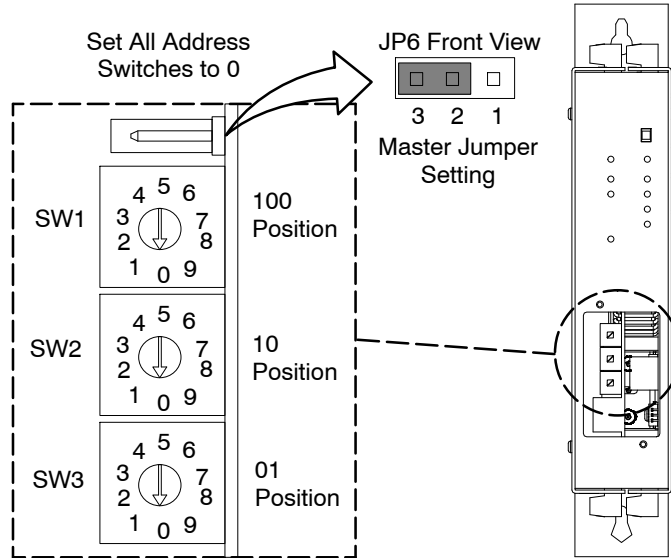

Figure 2 Factory Settings for Address Switches and JP6 Jumper Setting

NOTE: See the SC module manual for reference diagrams of JP6.

4. Replace the access plate on the front of the NC-1.
5. Repeat this procedure for all other NC-1 drivers.

Refer to Table 1 for all other settings.

Table 1 NC-1 Circuit Board Switch and Jumper Settings

Setting	Function/Procedure
Module Power Switch	Removes power to the NC-1 driver. The Default position is up (ON). Set switch to down (OFF) position before working on interface wiring or sensors.
Network Address Switches (SW1, SW2, SW3)	All address switches must be set to "0".
Watchdog Override Jumper (JP1)	CAUTION: Do not change the default setting of JP1 at pins 1 and 2. JP1 is for software development purposes only.
Input Reset Jumpers (JP3)	Set the jumpers on JP3 for either sinking or sourcing, depending on the reset input signal. Sourcing: Default, jumpers on pins 3 & 4 and 7 & 8. Sinking: Jumper pins 1 & 2 and 5 & 6. This input is required to unlatch the NC-1 from a fault condition.
Spray Trigger Input Jumper (JP4)	Set the jumpers on JP4 for either sinking or sourcing, depending on the trigger signal type. See Figure 4. Sourcing: Default, jumpers on pins 3 & 4 and 7 & 8. Sinking: Jumper pins 1 & 2 and 5 & 6. This input is used to trigger the lacquer spray gun.
Encoder Option Select (JP5)	CAUTION: Do not change the default setting of JP5 at pins 2 & 3. JP5 is for enabling encoder hardware for a future option.
Master/Remote Select (JP6)	CAUTION: The default setting of JP6 is Master, pins 2 & 3 jumpered. JP6 must be set to master for the NC-1 to function.
Optional A20A Gun Jumper	By default, the NC-1 is set for use with the MEG II spray gun. To use it with the A20A spray gun, install an 18 AWG gauge or larger wire to jumper J101-6 and J101-7.

Driver and Interface Boards

See Figures 3 and 4 to identify all the jumpers, switches, terminals, and ports on the driver and interface boards.

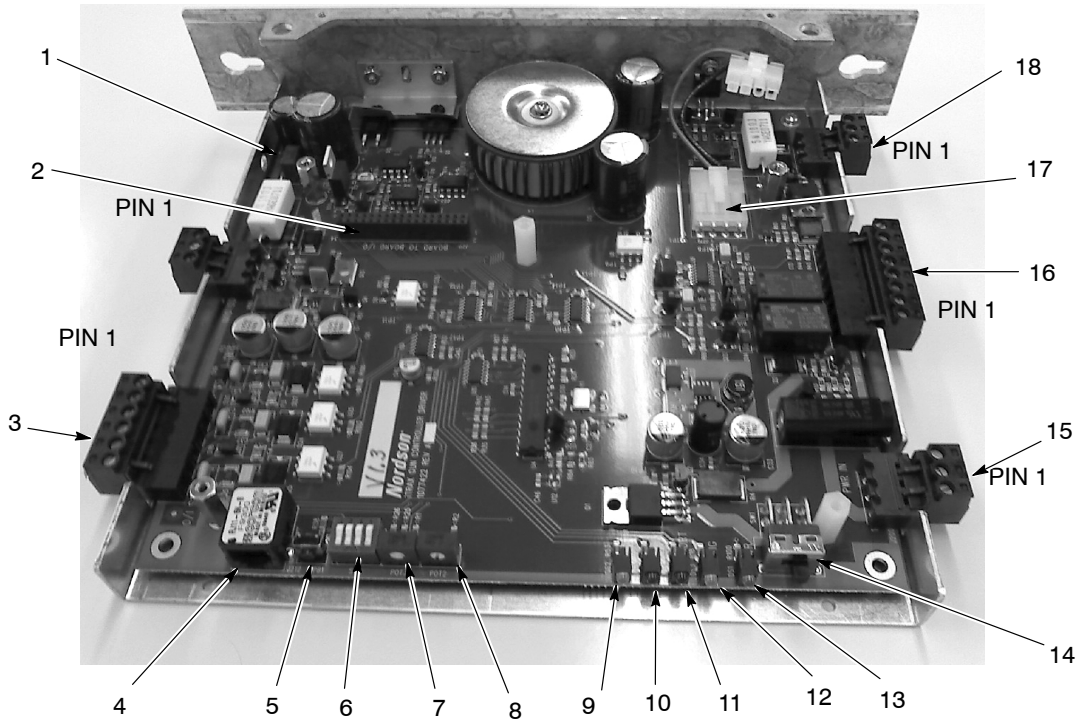

Figure 3 NC-1 Driver Board LEDs, Terminals, Switches, and Ports

Item	Component
1	POT1 48V Bus Adjust – Factory Set Do Not Change
2	P211 Board to Board I/O
3	P204 Future I/O
4	J212 CPU Program Port (RJ11)
5	PB1 Test/Cal – Factory Set Do Not Change
6	Mode Select – Factory Set Do Not Change
7	POT3 Peak Adjust – Factory Set Do Not Change
8	POT2 Hold Adjust – Factory Set Do Not Change
9	Out 2 LED
10	Open LED
11	Short LED
12	Out 1 LED
13	Power LED
14	Power Switch
15	P200 Power Input
16	P203 Fault Relays
17	J210 Power to Interface Board
18	P201 Gun

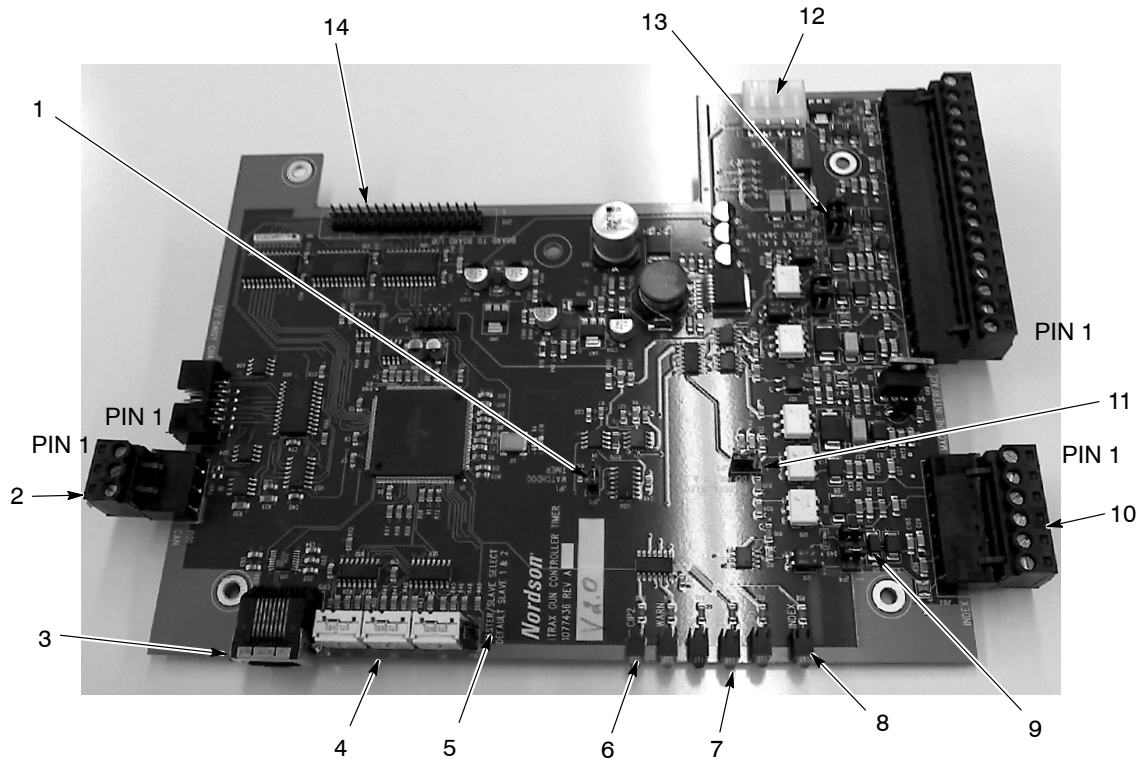

Figure 4 NC-1 Interface Board LEDs, Terminals, Switches, and Ports

Item	Component
1	JP1 Watchdog Override Jumper – Do Not Change
2	P100
3	J114 Diagnostic Port – Do Not Use
4	SW3 SW2 SW1 Node Address Switches – Set all to “0”
5	JP6 Master Select Jumper
6	MEG LED
7	Reset LED
8	Trigger LED
9	JP4 Trigger Input Sink/Source Jumper
10	P103 Trigger Input Wiring
11	JP5 Jumper – Do Not Change
12	J110 Power from Driver Board
13	JP3 Reset Input Sink/Source Jumper
14	J111 Board to Board I/O

Driver Mounting

NOTE: For compliance with the European Union Electromagnetic Compatibility Directive, refer to *EMC Directive Compliance* on page 6.

Mount the NC-1 driver using the two #10 mounting screws included with the controller. The mounting area should be free of vibration, excessive dust, and moisture. Ambient temperatures must not exceed 0–40 °C (32–104 °F).

Input and Output Connections

See Figure 5 for the input and output connections for a NC-1 spray gun driver. Use minimum 18 AWG wire for all connections.

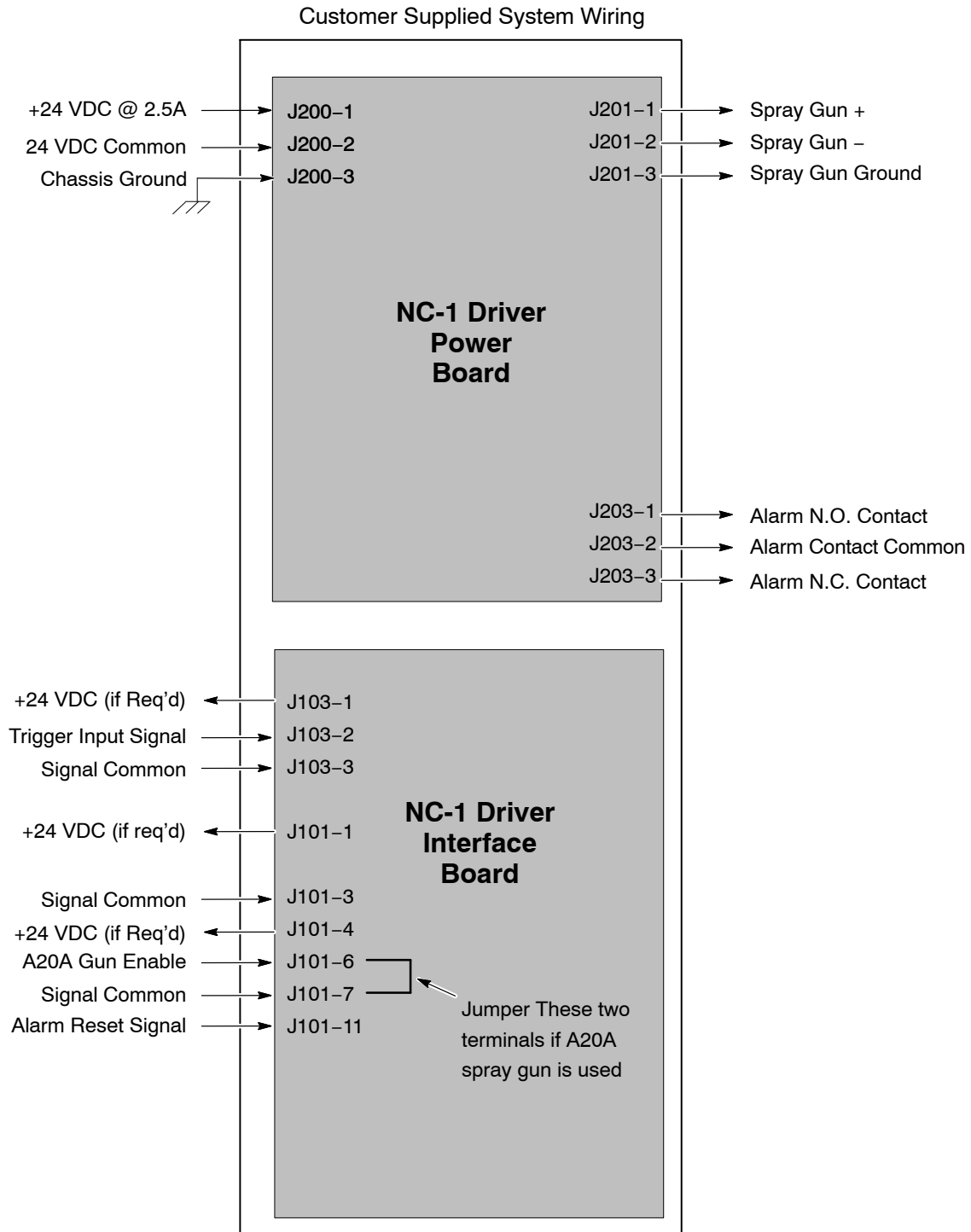

Figure 5 Input and Output Connections (system wiring is customer supplied)

System Wiring

Refer to Tables 2 and 3 and Figure 5.

NOTE: For compliance with the European Union Electromagnetic Compatibility Directive, refer to *EMC Directive Compliance* on page 6.

NOTE: Unless otherwise noted, all wiring is customer supplied.

Driver Signal List

Table 2 Driver Signal List

Conn. No.	Pin No.	Name and Description	Signal Specification	Signal Type	Note
POWER INPUT					
P200	1	POWER, Module Power Input	+24 Vdc +/- 1@ 2.5 amp max	Power Input	
P200	2	POWER, Module Power Input	24 Vdc COM	Power Common	
P200	3	POWER, Module Power Input	Chassis Ground	Chassis Ground	
GUN (MEG)					
P201	1	GUN +, Gun 1 Output +	Spike Drive, 48 Vdc 3 amps for 3 msec (all are maximum values), 1 amp holding current (maximum)	Source Output	
P201	2	GUN1-, Gun 1 Output Return	Spike Drive Return	Return	
P201	3	SHIELD, Shield termination	Chassis Ground	Chassis Ground	
FAULT RELAY					
P203	1	ALARM, Alarm Contact	30 Vdc @ 5 amp max	Normally Open Contact	A
P203	2	ALARM, Alarm Contact	30 Vdc @ 5 amp max	Contact Common	
P203	3	ALARM, Alarm Contact	30 Vdc @ 5 amp max	Normally Closed Contact	A
P203	4	Not Used			
P203	5	Not Used			
P203	6	Not Used			
P203	7	Not Used			
P203	8	Not Used			
NOTE A: Contact position when the module is powered off. The Alarm Relay operates in "Failsafe" mode. When the NC-1 is powered up, the N.O. contacts will close and the N.C. contacts will open. This is the normal failsafe condition. If an alarm occurs, or if power is removed the contacts will return to the "Power Off" state. The "Power Off" state of the contacts indicate an Alarm condition.					

Interface Signal List

Table 3 Interface Signal List

Conn. No.	Pin No.	Name and Description	Signal Specification	Signal Type
MACHINE INTERFACE				
P101	1	Not Used		
P101	2	Not Used		
P101	3	Signal Common	Signal Common	Common
P101	4	Not Used		
P101	5	Not Used		
P101	6	A20A Gun Select	Signal Input	Active Low Input
P101	7	Signal Common	Signal Common	Common
P101	8	Not Used		
P101	9	Not Used		
P101	10	Not Used		
P101	11	Reset Input	Signal Input (Default is source change JP3 for sink)	Active High Input
P101	12	Not Used		
P101	13	Not Used		
P101	14	Not Used		
P101	15	Not Used		
P101	16	Signal Common	Signal Common	Common
TRIGGER INPUT				
P103	1	+ Excitation (if used)	+24 Vdc +/- 4@ 0.25 A max	Excitation Output
P103	2	Trigger Signal Input	Signal Input (Default is source change, JP4 for sink)	Active High Input
P103	3	Trigger Signal Common	Signal Common	Common
P103	4	Not Used		
P103	5	Not Used		
P103	6	Not Used		

Operation

Power Switch



WARNING: Turn off external power to the NC-1 power supply before disconnecting power wires from connector P200. Failure to do so could result in an electrical shock.

LED Indicators

The NC-1 has 11 LEDs on the front panel:

LED	Color	Function
TRIGGER	Green	The Trigger input has been asserted
RESET	Green	The Reset input has been asserted
MEG	Green	ON = NC-1 configured for MEG gun (3A spike drive). OFF = NC-1 configured for A20A gun.
POWER	Green	Power is ON the NC-1
OUT1	Yellow	Power is ON the spray gun
SHORT	Red	Short circuit in the spray gun
OPEN	Red	Spray gun circuit is open

NOTE: To clear/unlatch an alarm, the Reset input must be asserted for minimum of 50 milliseconds, maximum of 1 second.

Parts

To order parts, call the Nordson Industrial Coating Systems Customer Support Center at (800) 433-9319 or contact your local Nordson representative.

Part	Description	Quantity	Note
1612378	CONTROLLER, NC-1 driver	1	
114876	• FUSE, 4.0 A, fast acting, 250V, 5 X 20 mm	1	
981145	• SCREW, pan, 10-24 x 0.500 in.	2	

EU DECLARATION of CONFORMITY

Product: iTrax Spray Control, iTrax PRx and NC1 control units for Container Product Line.

Models: iTrax Series modules and NC-1 module.

Description:

iTrax Spray Control – used as a timer / driver module for Container Applicators

iTrax PRx – electrically control pressure, monitors coating material temperature, monitors speed

NC-1 – used as a driver module for Container Applicators

These three units all have the same hardware but different software.

Applicable Directives:

2014/35/EU (Low Voltage Directive)

2014/30/EU (Electromagnetic Compatibility Directive)

Standards Used for Compliance:

EN60204 (2006)

EN55011 (2010)

ANSI/ISO 12100 (2012)

EN6100-6-2 (2005)

Principles:

This product has been designed and manufactured to the directive and standards / norms described above.

Certificates: DNV ISO9001



Date: 17Feb2017

Hallie Smith - Petee
Engineering Manager
Industrial Coating Systems
Amherst, Ohio, USA

Nordson Authorized Representative in the EU

Person authorized to compile the relevant technical documentation.

Contact: Operations Manager
Industrial Coating Systems
Nordson Deutschland GmbH
Heinrich-Hertz-Strabe 42-44
D-40699 Erkrath



Nordson Corporation • Westlake, Ohio

DOC12018-03