

12. International relations

Indian Diaspora

1. The **Indian diaspora comprises approximately 31 million people** contributing both via remittances and knowledge transfers to the Indian economy. These factors make India's engagement with its diaspora important, which has evolved over the years.
2. **Diaspora policy**
 1. In the **1990s the advent of liberalization** in India set the context for changes in diaspora engagement. The Indian diaspora in countries such as the USA had achieved significant **economic success and technical leadership** in sectors such as IT. **India was also looking for investments as well as knowledge transfer** from this section. In the gulf the diaspora had become an important source of **remittances**. The diaspora too was keen to maintain contacts with its cultural roots.
 2. **Diaspora engagement** received further fillip with the **introduction of the Pravasi Bhartiya Divas in 2003**. Unique initiatives such as the Person of Indian Origin (**PIO**) and Overseas Citizen of India (**OCI**) cards also date back to this period.
 3. **Government's outreach:** Recent **MEA efforts via twitter diplomacy**, passport assistance, **people-people ties, cultural engagements** have further ensured there remains a thriving connect with the diaspora.
 4. **Merger of PIO and OCI categories:** The **merger of PIO and OCI cards** has simplified procedural aspects of Diaspora's engagement with home.
 5. **Rescue efforts: Operation Rahat in Yemen in 2015** was in line with earlier such evacuation efforts in the 1990s.
 6. **Pravasi Kaushal Vikas Yojana (PKVY): A skill development program** targeted at **Indian youth seeking overseas employment** to make India the **skill capital of the world**.
 7. **Know your India programme (KIP): Youth-centric** outreach programmes include **Know India Programme (KIP)**.
 8. **Pravasi Bhartiya Kendra:** On the occasion of Gandhi Jayanti in 2018 the **Overseas Indian Centre was launched in Delhi**.

9. **Labour issues being faced by the diaspora:** **Minimum wage referral policy in the Gulf countries** have impacted labour welfare, with people seeking rehabilitation and other welfare measures.
10. **Engagement with Global talent:** From Google CEO Sundar Pichai, to Microsoft's Satya Nadella, to Bollywood projects such as Airlift – the diaspora has been in the centre stage owing to which the nature of the relationship between the government and people has evolved.

International Labour organisation (ILO)

1. It is the only tripartite United Nations agency - bringing together governments, employers and workers representatives from its 187 member states to devise international labour standards. It became the first specialized agency of UN in 1946.

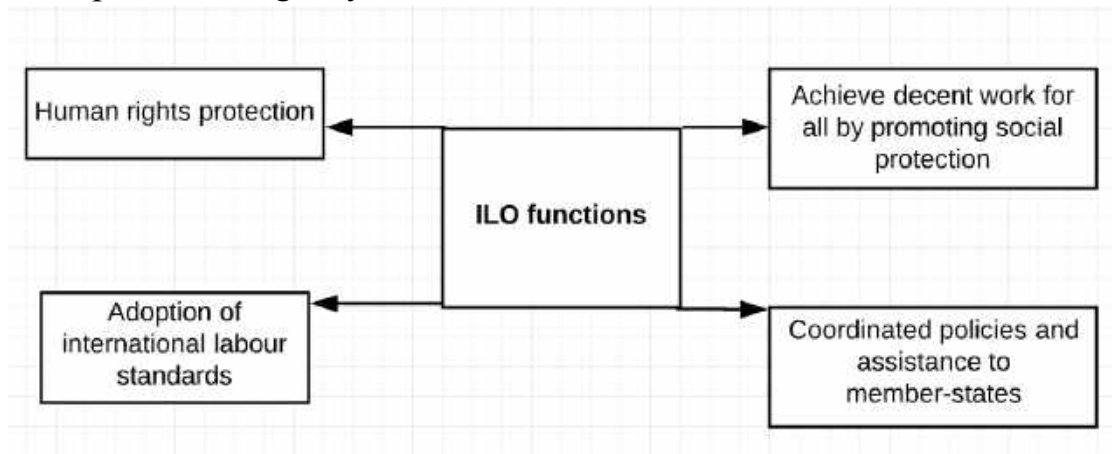

2. Contribution of ILO

1. **Workers right:** The **ILO Declaration on Fundamental Principles and Rights at Work**.
2. **Reducing forced labour and providing minimum wage scale:** The organisation has set uniform, universal standards for corporations to follow.
3. **Employment:** From advice to government policies to **direct training to poor communities**.
4. **Migrants:** **Protection of Migrant workers**.
5. **Reducing Child Labour:** **To eradicate child labour**, the ILO had launched **International Programme on the Elimination of Child**

Labour (IPEC) in 1992.

6. **HIV/AIDS:** The ILO is the lead UN-agency on **HIV workplace policies and programmes** and private sector mobilization.

3. Failures of ILO

- ILO has adopted a good number of conventions with a view to protect Labor rights. Unfortunately, still these **conventions are controversial as many of the countries did not ratify or accepted.**
 - Countries especially in **middle East Asia and Arabs like: Libya, Saudi Arabia, Iraq do not follow ILO conventions.**
- There is controversy on **definition of child Labor, domestic worker, and sex workers.** ILO has failed to **stop child Labor in Bangladesh, Pakistan, India and Sri Lanka**
- For the **domestic Labor ILO could not establish their stand.** In some countries e.g. **Qatit, Bahrain, Dubai, Saudi Arabia, Bangladesh, India** domestic Labor issue has been focused badly.
- **ILO has no clear-cut statement for the migrant labor.** In the developed countries like: **Australia, America, Singapore, Dubai, Kuwait, Brunei and Malaysia** migrant Labor is a critical issue.

Some Major Conventions ratified by India

- Child Labour Convention
- Minimum Age Convention
- Forced Labour Convention
- Abolition of Forced Labour Convention,
- Equal Remuneration Convention
- Discrimination (Employment and Occupation) Convention

4. To **coincide with its 100th year**, the ILO has announced a Global Campaign, **“Taking the ILO to the people”**, that demonstrates the relevance of the **organisation’s founding mandate to contemporary challenges** and its central role in helping build a fairer future for all.

Indian ocean

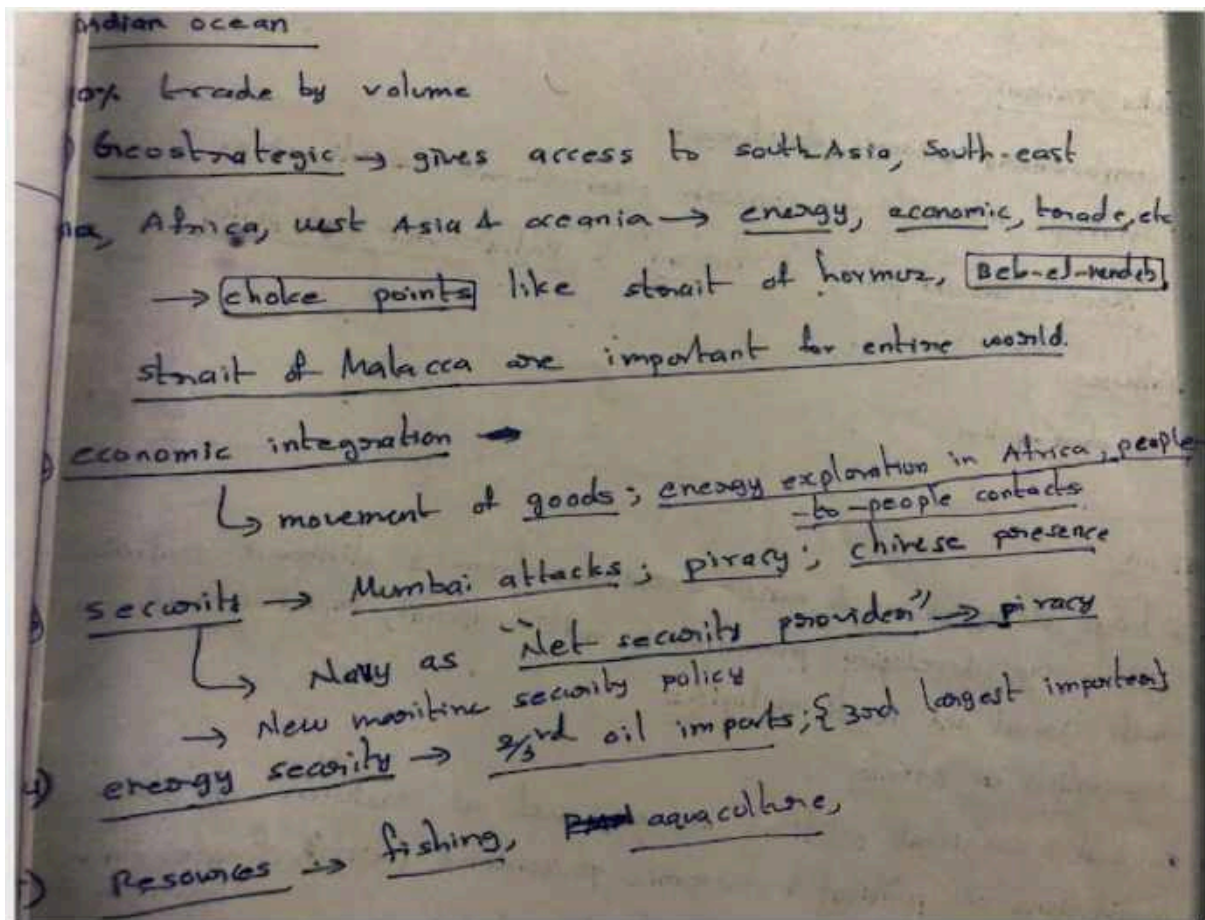

Economic importance

1. First, it enjoys a **privileged location at the crossroads of global trade**, connecting the major engines of the international economy in the Northern Atlantic and Asia-Pacific. This is particularly important in an era in which **global shipping** has burgeoned.
2. **2/3rd of India's oil imports** enter into and out of the Indian Ocean, including the Straits of Malacca and Hormuz and the Bab-el-Mandeb
3. The Ocean's vast drainage basin is important in its own right, **home to some two billion people**. This creates opportunities, especially given the **high rates of economic growth** around the Indian Ocean rim.
4. The Indian Ocean is rich in natural resources. **Forty per cent of the world's offshore oil production** takes place in the Indian Ocean basin.
5. **Fishing** in the Indian Ocean now accounts for almost **15 percent of the world's total**. **Aquaculture** in the region has also grown 12-fold since 1980.
6. **Mineral resources** are equally important, with **nodules containing**

nickel, cobalt, and iron, and massive sulphide deposits of manganese, copper, iron, zinc, silver, and gold present in sizeable quantities on the sea bed. Additionally, various rare **earth elements are present**, even if their extraction is not always commercially feasible etc.

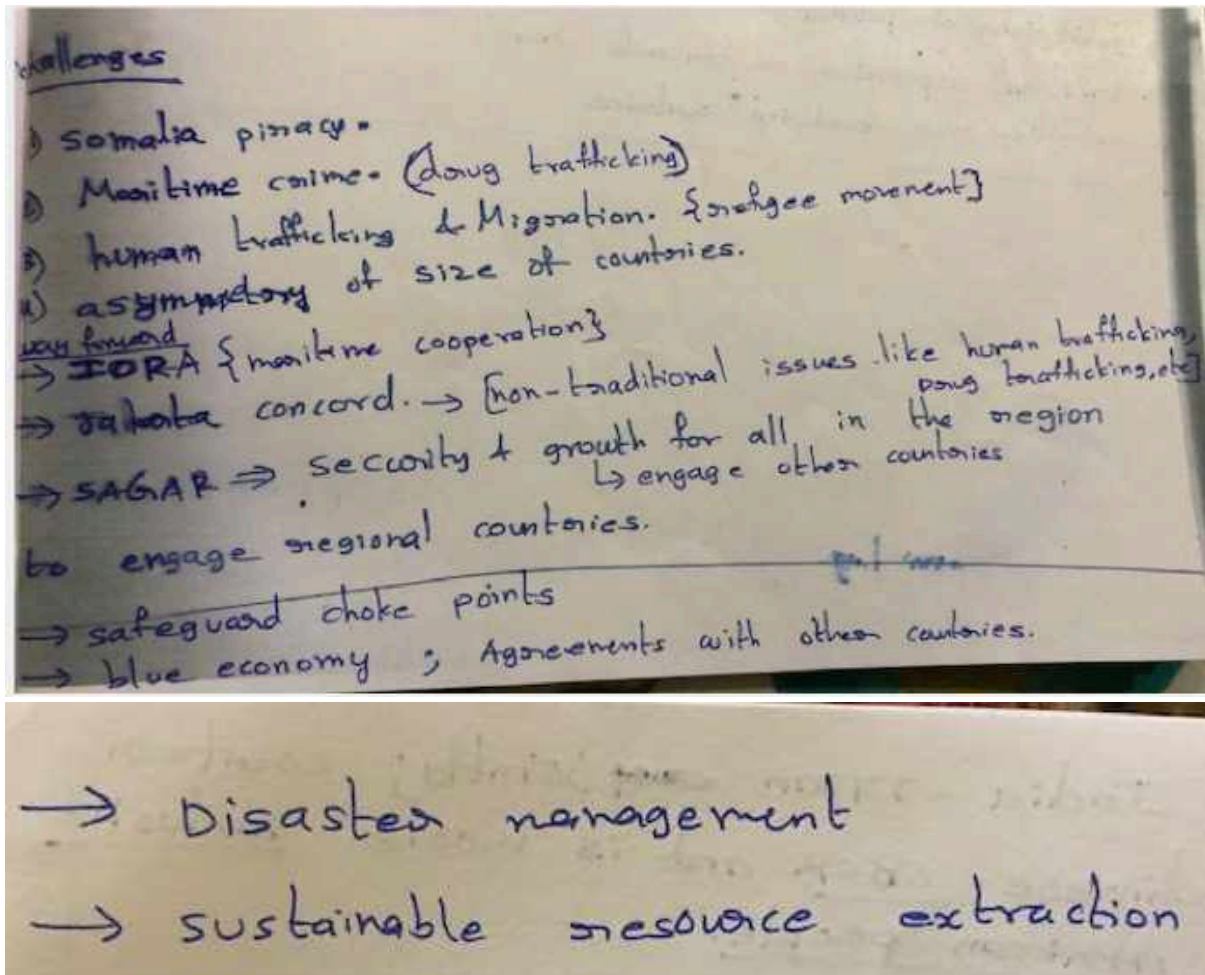

Steps taken by India to improve maritime security

1. **Sagarmala project** is being pursued, which aims to improve the port infrastructure and connectivity. McKinsey report states that the project can add 4% of GDP.
2. Joint **military exercises** like **Indira** (Russia), **Malabar** (US) have helped India portray its navy's might.
3. **Project MAUSAM** has been aimed at **connecting IO region countries** on ancient, cultural grounds.
4. **India's Necklace of Diamond policy** is aimed as a counter to China's

String of Pearls.

5. **Push for developing blue water navy** by reaching out to IO island nations.
6. Indian ocean's **International Fleet Review (IFR)** and heavy participation from various nations only **shows the increasing importance** that India is attaching to IO and its global acceptance.

How to secure Indian ocean

1. India should **boost Andaman and Nicobar with resources** to make it a centre for viable military outreach in IO region as well as in dominating the strategic sea-lanes and choke points.
2. **India should use its Geo-strategic advantage** to become **leader in IO region** by providing net security to IO region as recognised by Indian Maritime Security strategy 2015.
3. **Regional cooperation** should be enhanced through forums like **BIMSTEC, SAARC**, etc.
4. **MILAN platform** (navies from Indian ocean region) should be actively encouraged to **familiarise navies of littoral countries**, cultural know-how.
5. **Regional growth, prosperity and security** in the Indian ocean region should be increased through MAUSAM, SAGAR.
6. **Development of blue economy** should be extended to Mauritius, Sri Lanka, Maldives.

Africa

1. **India Africa relations date back to pre-independence era** and were **strengthened during the independence movement** of India. After India's independence India's non-alignment policy, anti-colonial, anti-racist stand brought India Africa even closer.

Africa → historically; anti-apartheid struggles

Importance

- 1) Resource rich → (pelindaba)
- 2) UNSC Reforms in global institutions
- 3) investment opportunities → ICT; energy; pharmaceuticals; Indian generic drugs
- 4) convergence on issues
 - terrorism - intelligence exchange
 - climate change - contributed least to climate change
 - peace keeping ops
 - democratic development

Convergence of interests in WTO -- MSP
- 5) people-to-people contact → students, medical tourism
- 6) Business-Business → (Generic drugs); solar mangan
- 7) Indian foreign aid to Africa → tele-education & tele-med

→ AARDO

challenges

challenges

- 1) political instability → **Civil war in South Sudan since 2013**
- 2) Terrorism in Africa → Boko-haram; ISIS
- 3) chinese presence → competition **India cant compete with China in Cheque book diplomacy**
- 4) Africans in India → racial attacks ⇒ negative image **Chinese investments around \$220 billion**

Djibouti military base

Lack of Coordination between Indian State and its businesses in Africa and the role of India Inc. is limited while drafting policies.

region by discussing growth corridor; to create free & open Indo-pac corridor

AAGC → is proposed by India-japan ~~and~~ jointly; counter balance to chinese OBOR and is more inclusive and consultative with African people.

Indian development initiatives in Africa

1. Indian Technical and Economic Cooperation (ITEC) that aims at

- capacity building, skill development, transfer of technology, etc.
2. **Pan-African e-network:** Launched in 2006, this is a joint effort of India and African Union with an aim to provide satellite connectivity, tele-education and tele-medicine services to the African countries.
 3. **Cooperation with African Development Bank (AfDB):** India joined AfDB in 1983 and has contributed to its general capital and has also pledged capital for grants and loans.
 4. **Solar Mamas:** It is group of rural women solar engineers from Africa who have been trained under Government of India supported programme to fabricate, install, use, repair and maintain solar lanterns and household solar lighting systems in their villages.
 5. **Development Assistance:** India has announced a US\$ 10 billion line of credit to help financing the projects in African countries, capacity building, IT education, and higher education.

Pacific islands

- India-pacific islands { Forum for India-pacific islands cooperation }
- 1) marine resources.
 - 2) Geo-politically important → china shares its boundary
 - 3) piracy issues.
 - 4) Indian origin people in Fiji.
 - 5) hydrocarbon exploration in vietnam.
 - 6) extended "Act-east policy"
 - 7) climate change & global warming.
 - 8) support India UNSC claim.
 - 9) Blue economy & Blue-navy
 - 10) strategic → counter china's influence.
 - 11) Trade & investment

Japan

India-Japan

- 1) shared concerns about china.
- 2) Japan's ageing population & India's DD.
- 3) India's rich natural resources & Japan's tech.
- 4) India - services; Japan - manufacturing.
- 5) Japan - capital; India - growing market.
- 6) CEPA
- 7) largest bilateral donor to India in transportation,

Power, environmental projects

→ New-delhi metro.

- western dedicated freight corridor (DFC)
- Delhi-mumbai industrial corridor (DMIC)
- rare-earth metals
- Dedicated task force to facilitate Japanese investments
- 'smart cities' project cooperation.
- peaceful uses of nuclear energy

Nuclear deal

- First civilian nuclear cooperation.
- responsible nuclear power.
- energy-security of India.
- clean energy → Paris deal.
- US-based reactors.

1. "Toward a Free, Open and Prosperous Indo-Pacific". "Rules-based order" in the Indo-Pacific region.
2. India-Japan \$75 billion currency swap.
3. Comprehensive Economic Partnership Agreement (CEPA) signed in 2011.
4. India's mega infrastructure projects like the Delhi-Mumbai Freight Corridor, Delhi- Mumbai Industrial Corridor, Chennai-Bangalore Industrial Corridor and the Ahmedabad-Mumbai High Speed Rail system.
5. North East integration- India's Act east policy has North east development at its core.
6. Outside India- Asia-Africa Growth Corridor (AAGR) announced in 2017 and joint projects in some third countries like Bangladesh.
7. Defence ties- Quadrilateral Security Dialogue is a strategic dialogue between India, United States, Japan and Australia will be carried out.

8. Trilateral naval exercise called Exercise Malabar.
9. **Conclusion:** It is clear that the government has set India-Japan ties on an accelerated geopolitical course that will be a major factor in its dealings with the rest of the world.

China's one belt one road initiative

1. Silk road initiative of China involves **building infrastructure**, setting up of **industries** and boosting **people to people contacts** in the regions proposed in the silk road plan. The One Belt, One Road (OBOR) consists of Silk Road Economic Belt (**SREB**) and the Maritime Silk Road (**MSR**).
2. **One Belt**, mainly known as SREB, implies **land corridor connectivity from China** to Central Asia and **West Asia**, going all the way to **Europe**. One Road, known as MSR, implies maritime connectivity through the **Strait of Malacca to India**, and onwards to West Asia and East Africa.
3. **Reasons why China is building it**
 1. China's export and FDI driven economic model is losing its effect. So China needs to **find new export markets**.
 2. **80% of China's imports** come from **Strait of Malacca which is pirate infested**. So, China wants to secure this lane and avoid this to large extent.
 3. The **growing disparity** between **Coastal China vs Inland China** is creating social problems, helping extremists and people becoming more vocal. Hence **China** needs to develop **those 12 inland regions**.
 4. Since 2011, because of **South China Sea dispute**, China's relations became **bitter** with Cambodia, Laos, Thailand, Malaysia, Japan. New Silk Road policy seems to be aimed at **defusing tensions** via soft language and **economic offer**.
 5. China want to counter **USA's pivot to Asia policy**, **TPP** and other interventions of US in South eastern Asia like in Myanmar.
 6. China wants to gain access to **Bay of Bengal and Indian ocean**. So, need better relations with Myanmar and ASEAN.
 7. **Reviving its ancient cultural link**.
 8. **Encircle India**. Revisionist policy of China.

9. Strengthen **China's Yuan**.

4. **Benefits to India**

1. The project will enhance **India's connectivity with Central Asia** which will **increase trade** and people to people movement and ties.
2. The proposed road, could bring in some **serious investment** in the otherwise poor and less invested eastern part and **Northeastern part of India**, and thereby creating employment and industries.
3. Pakistan and China relations are on a high since the China-Pakistan economic corridor being launched. India can retain the **balance of power in South Asia**.
4. The proposed route also is a **hub for hydrocarbon trade**. The route could act as a bliss for transfer of oil and petroleum products from not only Gulf but also from Indonesia through the Straits of Malacca.
5. India too through its **Look-east policy (LEP)** is trying to envisage a friendly neighbourhood with East Pacific countries. This can create such potential **friendly neighbours**.
6. The south Asia region is bustling with opportunities, and dissolving **trade barriers** and creating a favourable economic situation is the need of the hour.

5. **Challenges**

1. OBOR's flagship project is the China-Pakistan Economic Corridor (**CPEC**), which runs through the **Gilgit-Baltistan** region, ignoring India's "sovereignty and territorial integrity".
2. India claims that China has never fully explained its plan for the Belt and Road initiative. There is a lack of **transparency in China's agenda**.
3. B&RI infrastructure project structure smacks of **Chinese neo-colonialism**. The projects could push **smaller countries** on the road into a crushing **debt cycle**, destroy the **ecology** and disrupt local communities.
4. Analysts believe that Chinese control of **Gwadar port** is a part of **String of Pearls strategy** aimed at encircling India. The port is located just **outside the Strait of Hormuz**, which handles 20% of the global **oil trade**. Thus it is a vital choke point in the Indian ocean.
5. India's monopoly in Indian ocean may be eroded and **China will**

get legitimacy in the Indian ocean region. This may well bring in conflicts in this region with any kind of China's assertion in the future.

6. Since African resources are China's focus right now, the project could well be a surrogate for a giant Chinese SLOC running all the way from the East African coast, to the Southern coast of China.

6. Challenges with CPEC

1. **Threat to India's sovereignty:** CPEC passes through Pakistan occupied Kashmir (POK) which is still a disputed land and integral part of India. Also China has stepped up its military activity in region in of security to corridor.
2. **Political concerns:** It symbolises strengthened relationship between China-Pakistan, and increases the chance of China's intervention in bilateral matters of India-Pakistan to protect its own interest.
3. **Security:** In any future war with China, China can use this route to mobilise its army to India's western side and also use Gwadar port as its naval base. China's maritime presence in Gwadar port can be highly detrimental to India's imports oil.
4. **Economic concerns:** This will reduce China's distance to Africa by 12000 kms. The effective use of this corridor will reduce the India's exports to Western Europe, West Asia and Africa. India was having an advantage to shorter sea route to Africa and Europe, which will be challenged after CPEC successful implementation.
5. As the new trespass unfolds, India must not lose an opportunity to communicate its concerns to the international community. It also needs to muster efforts to ensure that its territorial position is not diluted further in order to avoid past situations such as Tibet and Aksai Chin.

7. India's efforts

1. **Project Mausam:** Project Mausam would allow India to re-establish its ties with its ancient trade partners and re-establish an Indian ocean world along the littoral of the Indian ocean.
2. **Indian Ocean Rim (IOR) Association:** It is based on the principles of open regionalism for strengthening economic

cooperation particularly on trade facilitation and investment, promotion as well as social development of the region.

3. **Joint partnerships:** India has joint mechanisms with Sri Lanka and Maldives for shared maritime domain awareness. India has also been encouraging Mauritius and Seychelles for joining this mechanism that will enhance maritime security in the IOR.
 4. **BIMSTEC and SAARC:** India is playing proactive role in ensuring success of these institutions as forum of effective multilateral and regional cooperation.
8. Given the endorsement from the UN Secretary General, who said the OBOR is rooted in a shared vision for global development, India should not simply sit out the project. India and Japan have come up with Asia Africa Growth Corridor (AAGC) to counter China's OBOR.

China's string of pearls

- Cocos island in Myanmar
- Chittagong in Bangladesh
- Hambantota in Sri Lanka
- Maao atoll in Maldives
- Gwadar in Pakistan

China's dams on Brahmaputra → no formal treaty.

[Jirex, Zangmu and Tiacha]

3) western boundary with China.
↳ McDonald line
→ Johnson line

4) eastern boundary
↳ McMahon line { Shimla conference }

⇒ India & China (in 2003) → special representatives to discuss border question.

5) Pakistan acquisition of submarines from China.

Way forward → communicate concerns to international community.

→ close power gap by building capabilities

→ Cooperation

→ engagement with Japan, US and EU.

→ Mending fences with our neighbors.

→ Hotline between Director General of military.

→ Border Defence cooperation agreement of 2013.

India-USA

1. **Trump's 'America First':** America First refers to a foreign policy that **emphasises American nationalism and unilateralism**. It first gained prominence in the inter-war period and was advocated by the America First Committee, a non-interventionist pressure group against the American entry into World War II. Since 2016, an identically-named foreign policy that emphasizes similar objectives has been pursued by the administration of U.S. President Donald Trump.

1) Significance of USA for India

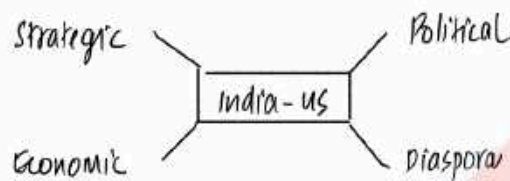

2) Bilateral relations (Present Phase)



3) Defence relations



1) Foundational Agreements of US signed by India

- 1) GSOMIA (General Security of Military Information Agreement). It allows sharing of classified information
- 2) LEMOA (Logistics Exchange Memorandum of Agreement). This will enable both the countries to use each others bases for various operations. This include port visits, joint exercises, disaster relief, refuelling etc

- 3) COMCASA (Communications Compatibility and Security Agreement). This aims to strengthen interoperability between militaries and sale of high end technology
- 2) STA-1 Status (Strategic Trade Authorisation-1). It will allow India to buy highly advanced and cutting-edge sensitive technologies from USA
- 3) 2+2 Dialogue. It is a dialogue mechanism established between ministers of Defence and External Affairs of India and USA. It is aimed at enhancing strategic cooperation between both countries

Pros	Cons
<ul style="list-style-type: none"> 1) <u>Defence relations has become the major pillar in the relationship</u> 2) <u>The foundational agreements will help in enhancing Indian defence capabilities</u> 3) <u>It will help in security cooperation</u> 4) <u>India would get access to high end technologies</u> 5) <u>ensure regional balance of power</u> 	<ul style="list-style-type: none"> 1) <u>US geo-strategic interests in South Asia and Indian Ocean</u> 2) <u>Foundational Agreement symbolises a defence alliance with USA</u> 3) <u>Emerging Russia-china-Pak axis</u> 4) <u>May compromise the secrecy of Indian military communication system</u> 5) <u>India may inclined to increase defence imports from USA</u>

4) Trade Relations

- 1) USA is India's second largest trading partner and largest export destination
- 2) India is having a trade surplus with USA
- 3) Trade war
 - i) US imposed tariff on steel and aluminium imports from India
 - ii) US has withdrawn GSP (Generalized system of Preferences)
 - iii) US is imposing strict restrictions on visas (for Eg. H1-B, L1 visas)
 - iv) US dragging India into WTO
- 4) IPR issues
US want stronger IP regime and is a major issue in pharma sector

A) Issues

- i) It will affect India's exports to US under GSP
- ii) Withdrawal of GSP affect the labour intensive sectors like leather, gems and jewellery etc
- iii) The visa restrictions affect the IT sector India
- iv) US in its special 301 report put India under weak IP regime - "Priority watch list" category
- v) The competing ideas - "Make in India and America first"

US Sanctions & India

- 1) US passed CAATSA (Countering America's Adversaries Through Sanctions Act)
- 2) Under the Act, US could impose sanctions on any entity carrying out significant defence energy trade with sanctioned entities in Russia, Iran & North Korea
- 3) Issues
 - 1) The sanctions would affect India's relations with Russia and Iran
 - 2) Russia is India's one of the major defence partner
 - 3) India and Russia signed S-400 deal in 2018
 - 4) Iran is a major energy supplier to India
 - 5) India is developing Chabahar port in Iran

US Partially Allow India To Continue With Iranian Oil Import (Ended)

1. The US has agreed to let eight countries including China, Japan, India and South Korea keep buying Iranian oil after it reimpose sanctions on the Iran on November 5. It would allow Indian oil companies to continue to import about 1.25 million tonnes of oil a month till March 2019 from Tehran.
2. The Islamic Republic had become a preferred supplier for India, making it the second largest Iranian crude oil purchaser of Iranian oil after China due to sweeteners such as 60-day credit, free insurance and shipping.

Conditions Of Waiver

- India had imported about **22 million tonnes** of crude oil from Iran in 2017-18 and planned to raise that to about **30 million tonnes** in 2018-19. But, as a condition of waiver, Indian oil firms will reduce their imports significantly. Indian companies can import 1.25 million tonnes a month up to March 2019, the same as they ordered for October and November 2018.

-
- **Not To Drive Up The Oil Price:** While the Trump administration's goal remains to choke off revenue to Iran's economy, waivers are being granted in exchange for continued import cuts so as not to drive up oil prices.
 - **Temporary Exemptions:** The waivers are only temporary, and the U.S. will expect countries that get them to keep cutting Iranian imports in the months ahead.
 - **Payment Mechanism:** The Indian side, while building its case for a waiver, assured the US that the payment mechanism between India and Iran ensure that Iran can't use oil money from India for any terror-related activity, a key American concern. Thus, countries that get waivers under the revived sanctions must pay for the oil into escrow accounts in their local currency. That means the money won't directly go to Iran, which can only use it to buy food, medicine or other non-sanctioned goods from its crude customers. The US administration sees those accounts as an important way of limiting Iranian revenue and further constraining its economy.
 - **American Oil Import:** During the negotiations, India also told the US that it would like to import more American oil if it came on competitive terms.

US trade war

○ Trade war

- Trade war
 - When a country imposes trade barriers in order to negatively impact another country's trade
 - The trade war between USA and China has far reaching effects on the global economy
- Present situation
 - USA increased tariffs by 25 percent on imports of steel and aluminium from all over the world including 3 billion worth of supplies from China. (China is world's largest supplier of steel and aluminium)
 - China retaliated by imposing tariffs on US goods
 - India too joined the trade war by imposing tariffs as high as 50% on a list of 30 imported goods from USA.
 - EU also imposed tariffs on American goods

→ Reasons

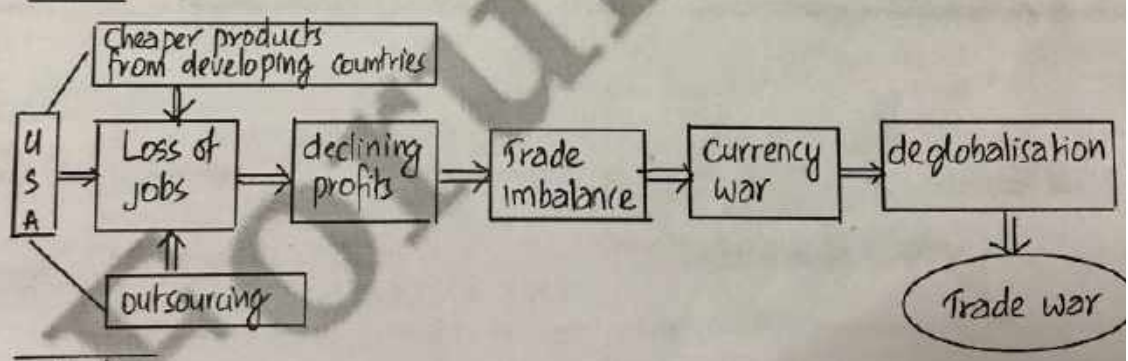

→ Implications

- Negative
- undermines rule based order and WTO
- disregard for trade principles
- real issues remain unaddressed (Eg Currency manipulation)
- trade war would impact global economic recovery
- affect investor confidence
- disproportionately affect developing countries
- reduce overall global trade and global supply chains

1. "Trade war is a loss loss situation" -- Raghuram Rajan.

Various forums to address trade related disputes

1. **World trade organization (WTO):** The main objective is to **help producers of goods and services**, exporters and importers conduct their business.
2. **United Nations commission on international trade law (UNCITRAL):** To promote **modernization** and **harmonization** of international **trade law**.
3. **UNCTAD:** It is **dealing with trade, investment, and developmental issues**. It formulates policies related to all aspects of trade, aid, transport, finance and technology.
4. **International chamber of commerce (ICC):** ICC has three main activities; **rule setting, dispute resolution**, and policy advocacy.
5. **International center for settlement of investment disputes (ICSID):** International arbitration institution established for **legal dispute resolution and conciliation** between the **international investors**.
6. **Permanent court of arbitration (PCA):** **PCA has jurisdiction of disputes** based on PCA founding documents.
7. **Regional organizations:** **G20, ASEAN, BIMSTEC, OPEC, APEC, OECD, NAFTA** have protocols related to resolving trade disputes.
8. **Commercial courts in India:** **Commercial Courts Act, 2015** provides for constitution of commercial courts, commercial division and commercial appellate division in **high courts** for adjudicating commercial/trade related disputes.
9. **ADR:** **ADR has been given preference to solve commercial and trade related disputes** in India over the years and has also been given **legislative backing**. Example: Under section 442 of the Companies Act, 2013 etc.
10. There are no framework that-one size fits all. ADR such as **arbitration, mediation, conciliation, negotiation** and **collaborative law** can offer a means of **settling disputes** without resorting to commercial litigation, aiming to resolve disputes in a way that is less expensive, faster and more predictable than the adversarial litigation process.

The regulatory environment is not robust enough to ensure the disputes do not arise

1. **Legal routes:** The order made by these dispute forums can be

challenged in judicial courts in member countries which damages the credibility of these forums in the longer run. Ex: Antrix corporation and Devas media case.

2. **Non-Binding:** Majority of these forums' verdicts are **non-binding** and also these do **not have any authority to implement** their decisions there by eroding their significance.
3. **Conflicting provisions:** International /regional trade agreements and member countries trade rules have **conflicting provisions** there by creating various disputes.
4. **Uniformity:** There is a lack of uniformity among various forums and **no uniform acts to guide them**. It is based on arbitration and **party with better arbitrator wins**.
5. All countries debate on their **vested interests** to guard their resources and welfare of their own people. **Chance of non-consensus of multilateral agreements** by member countries, this lead to prolonging of the issue. **Lack of technical expertise** to resolve the disputes especially in India's case leading to biased/unsatisfactory outcomes.

Russia

Russia

- Russia's tilt towards China.
- military exercise with Pakistan.
- Russia did not back India's demand to name Pakistan based terror groups.
- India against Russia favouring of participation of ~~India~~ Taliban in Afghan peace process.
- India - USA ties.

Importance — "privileged strategic partner"

- 1) Energy requirements — natural gas Sukhoi S-30 and Brahmos
 - 2) Top defence partner { Brahmos missile } { co-production }
 - 3) Technology transfer { space } ; Nuclear power { Kudankulam }
- USSR launched India's first two satellites - Aryabhata and Bhaskar. Help in developing cryogenic technology.
- 4) Russia is major market for Indian goods → pharma
 - 5) Geopolitically → balancing force against China & Pak designs.
 - 6) old friend → building new world order.
 - 7) cross-border terrorism agencement. (CCIT)
 - 8) INSTC
 - 9) Arctic shelf exploration.
- Russia has supported India's bid for permanent seat in UNSC. It has been favouring Indian entry to NSG

West Asia

1. India's west Asia policy

1. India has a strong influence in the West Asia and North Africa due to various reasons like **old civilisational ties with Egypt**, Mesopotamia, Persia, old sea trade routes, **Khilafat Movement**

days and the **Non Aligned movement (NAM)**. Today the region holds immense importance for an aspirational India.

2. For decades, **India was a passive player** in West Asia and a **beneficiary of good relationships** with various multiple actors. Historically, India's West Asia policy has been multi directional.
3. **During the cold war years**, India maintained **close economic** cooperation with both Saudi Arabia and Iran, the rival poles in regional geopolitics.
4. In the post-Soviet world, the **bi-directional approach** has been expanded to a **tri-directional foreign policy** to accommodate the three key pillars of West Asia which include Saudi Arabia, Iran and Israel.
5. In 2010, India and Saudi Arabia signed **Riyadh Declaration**, which set the framework for **cooperation** in the **security, defence** and **economic** spheres. Since then, there has been a marked improvement in security cooperation and intelligence sharing between India and Saudi Arabia.

2. Why India lost ground in West Asia

1. **India's stance** has often **vacillated on key issues** as is evident from **voting patterns** in the UN. For example India **abstained from voting on Libya** and did not oppose when the West pushed for regime change.
2. In Syria, **India did not raise voice** against USA decision to **arm moderate Syrian rebels** despite India's own **bitter past** with arming of Taliban by Pakistan.
3. **India voted against Iran** on the **nuke issue** presumably under the US pressure, despite the engagements like **Chabahar port** and **Delaram highway**.
4. The **Palestine issue** seems to be another area where **India is facing problems** due to increased trade in defence with **Israel** and silence is construed as endorsement of human rights violation. India's role seems to have been limited to evacuating its citizens from war torn areas. The most glaring evidence is lack of diplomatic and high level visits.

3. What can India do

1. While **trade is a significant** component of our interaction with

west Asia, but the essence will be the **multi dimensionality** of its character. As much as India trades with the region, also important are the issues of **security, culture, people to people linkages**, and those of a wider geopolitical and geo strategic nature.

2. India should make a policy pronouncement on **Look West Policy (LWP)** on the line of Act East Policy.
3. India needs to **deepen the political contacts**. It is time for India to have a **series of high level visits** to enhance its political image and allay the apprehensions about India's neglect of the region.
4. India can devise a mechanism to **promote its films, sports and music in the region** which would be of great assets to establish India's **soft power** status which in long term might constitute the component of Indian diplomacy.
5. There is growing perception that **Arab Spring has transformed** into an Arab- Persian cold war. The **two countries** being the regional powers are crucially important for India and the strategic and economic relevance of them cannot be undermined.
6. In recent years, **India has succeeded in mobilising the alliances** in the region in its fight against **terrorism** and so, India should try in a more vigorous manner and opt for a deep **strategic engagement** to muster the supports of its political class to fight the terrorism.

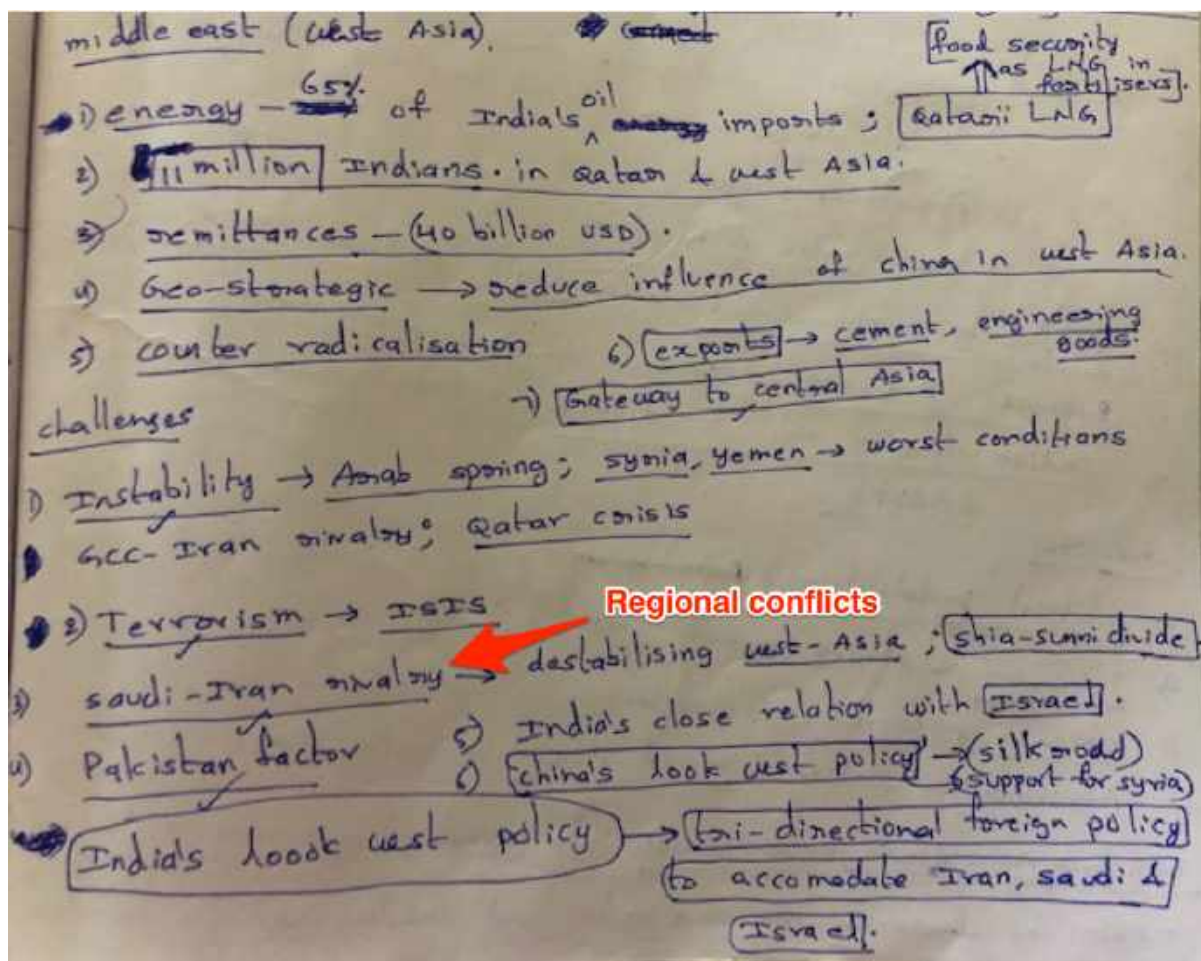

1. **Involvement of global and regional powers:** The involvement of extra-regional players such as the USA and Russia in the internal conflicts in West Asia has further aggravated the situation.
2. **US Sanctions on Iran:** US withdrawal from Iran nuclear deal and has threatened to impose economic sanctions on Iran. This may weaken the dialogue mechanisms, embolden conservatives and may threaten the regional stability even more.

Central Asia

1. **1st India-Central Asia Dialogue** was held in Uzbekistan and was co-chaired India. India was among the first countries to recognise the five Central Asian states. It established diplomatic relations with them after they gained independence in 1990s. India now considers the Central Asian countries as part of its 'extended and strategic neighbourhood'.

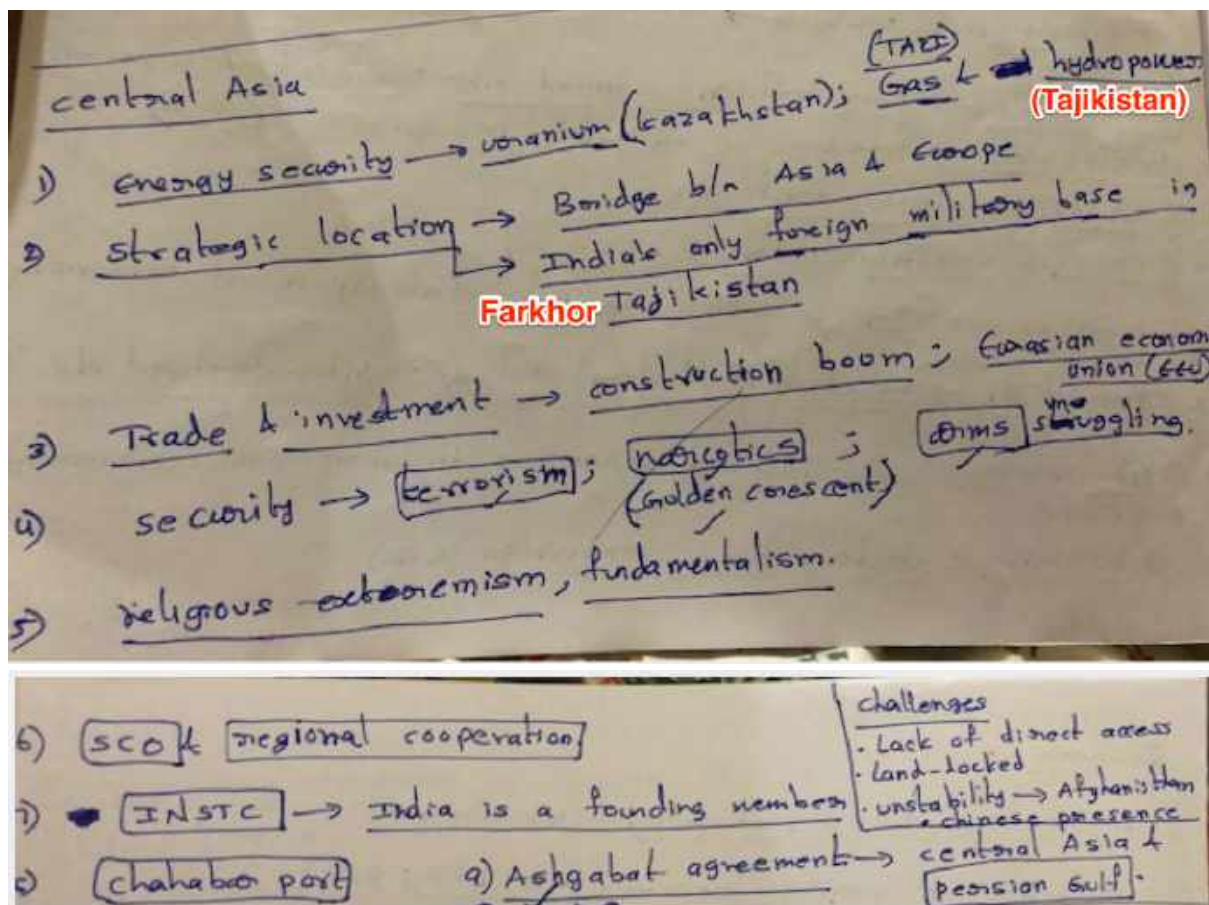

1. Fergana valley -- Hotspot of Terrorism.

India efforts to connect with Central Asia

1. **Connect Central Asia Policy:** Strong political relations, Strategic and security cooperation, Long term partnership in energy, Increase presence of Indian firms in CARs.
2. **Shanghai Cooperation Organization (SCO):** more frequent summit level contacts between the top leaderships of India & CARs.
3. **International North-South Transport Corridor (INSTC):** It is a project to link India and Iran via the sea route and then through Iran to the Caspian Sea onwards to Central Asia.
4. **Ashgabat Agreement:** India has acceded to the Ashgabat Agreement, an international transport and transit corridor facilitating transportation of goods between Central Asia and the Persian Gulf.
5. **Development of Chabahar port in Iran.**
6. **Turkmenistan-Afghanistan-Pakistan-India (TAPI).**

7. **Eurasian Economic Union (EEU).**
8. **Indian Technical and Economic Cooperation (ITEC) Programme.**

SCO

1. SCO is a Eurasian political, economic, and military organisation. **SCO is seen as an attempt by China & Russia to challenge the western dominated global order.** Currently, SCO has 8 Member States - China, Kazakhstan, Kyrgyzstan, Russia, Tajikistan, Uzbekistan, India and Pakistan.
2. **Significance of SCO's membership to India**
 1. **Security:** SCO's main objective of **working cooperatively against "three evils"** of **terrorism, separatism, and extremism** is in consonance with India's interests. **Regional Anti Terrorist Structure (RATS).** Both Central Asian Region countries and India face serious threat from **illegal drug** trade emanating from 'Golden Crescent' of opium production.
 2. **Pakistan:** It could be a platform for **bilateral negotiations** with Pakistan on issues of mutual interest.
 3. **Connectivity:** SCO is also a potential platform to advance **India's Connect Central Asia policy.** This is much in line with India's focus on connectivity as evident India's efforts - **INSTC & Ashgabat Agreement,** construction of **Chabahar Port** and setting up an air **freight corridor** between Kabul, Kandahar and New Delhi.
 4. **Economic interests:** With SCO countries contributing almost **42% of the world population and 20% of the GDP,** the proposed FTA with Eurasian Economic Union can provide India with a **wider market base for its IT, tele-communications, banking, finance and pharmaceutical industries.**
 5. **Energy & Minerals:** SCO countries along with Iran, Azerbaijan & Turkmenistan hold some of the **largest oil (~25%) and natural gas reserves (~50%)** of the world. **Kazakhstan is the largest producer of Uranium.** Uzbekistan & **Kyrgyzstan** are important regional producers of **Gold.** **SCO Energy Club** can facilitate

deeper interactions between producers (Russia, Kazakhstan, Uzbekistan and Iran) and consumers (China, Tajikistan, Kyrgyzstan, India, Pakistan and Mongolia).

6. **Political significance:** SCO also provides a stage to India for achieving some of its foreign policy goals. It will help India to play an active role in its **extended neighbourhood**.

3. Challenges

1. **Trust Deficit:** Between members like India & Pakistan and India & China can be major drag on the effectiveness of the organisation.
2. **China's Belt and Road initiative:** India's position on BRI is contrary to other members, all of which have supported the initiative. **China's Marshall plan and Monroe doctrine**.
3. **Global geopolitics:** The **growing proximity of Russia and China** and India's attempts towards better relations with the US makes the organization vulnerable to competitive geopolitics.
4. **Definition of terrorism:** **India's definition of terrorism is different** from the **definition of SCO under RATS**. For SCO, terrorism coincides with regime destabilisation; whereas for India it is related to state-sponsored cross border terrorism.
5. **Limited existing economic footprint:** **India's bilateral trade with Central Asia stands at about \$2 bn** and with Russia about \$10 bn in 2017. In contrast, China's trade with Russia has crossed \$100 bn in 2018 and stands at over \$50 billion with Central Asia.
4. Whether the SCO grows into a successful regional forum **depends on its ability to overcome bilateral differences** between its members and their respective geopolitical calculations.

SAARC

1. **South Asia is one of the world's least integrated regions**, India is one of the world's least regionally-integrated major powers. SAARC was conceived to make the south asian region a thriving example of **mutual cooperation, self-reliance and peaceful coexistence**. Greater economic integration, promotion of welfare of people and improvement in their quality of life has been the central objectives. But the region is full of contradictions which include divergent security interests and the Indo-

centric nature of the region.

2. Problems

1. SAARC suffers from a built-in **contradiction**. India's **disproportionately large size inhibits** its neighbour's participation as **equal partners**, crucial in any cooperative endeavour.
2. Except for India, no other country shares a **boundary** with another. And India has **boundary disputes** with its neighbours, which inhibits the negotiations.
3. Except for Pakistan, **India perceives no threat** from any other country within the region. Others feel India as a threat. This dichotomy in the region's perceptions does not augur well for the SAARC.
4. **Diverse political** culture also poses problems.
5. **Indo-Pak conflict** always takes the centre stage and clouds all other issues.
6. **Lack of confidence in each other**. For example, inter-state trade is still minuscule. India is a potential supplier of industrial goods and services to almost all the South Asian states but they prefer to depend on the industrial West, Japan, and even China instead of India.

3. Way forward

1. India should facilitate building **regional infrastructure**, creating **better connectivity** within the region.
2. India can **also implement trade facilitation measures** which would lower cost of transportation of Goods and services and give a boost to trade, investment and employment in the region.
3. SAARC members have geographical contiguity, complemented by **cultural commonalities** between them. India should make use of this to **forge people to people contacts** for **better relations**.
4. South Asian countries do not have the **financial wherewithal to execute projects**, it is very important to allow **private sector** to participate.
5. It is also important to put in place the **technical infrastructure for greater energy connectivity**. It is important for India to rectify such technical shortcomings to **facilitate regional power exchange**. To make this initiative work, the governments within the region

will need to synchronise their efforts on a range of technical, institutional and political issues.

6. Unless there exists a strong **political will** among the participating countries for a sustained period of time, this initiative faces the danger of meeting a fate similar to that of several other proposals under SAARC.
4. Thus by **using SAARC as a platform**, India **can enhance regional cooperation** which can attenuate **inter-state conflicts** and improve **bilateral relationship** and economic integration in the region. Such a regional co-operation can also augment India's leverage vis-a-vis the greatest power of South Asia.

India and its neighbourhood

1. The Narendra Modi government's neighbourhood policy began exceptionally well with Mr. Modi reaching out to the regional capitals and making grand foreign policy commitments. But almost immediately, things changed, when it tried to **interfere with the Constitution-making process** in Nepal and was accused of trying to **influence electoral outcomes in Sri Lanka**. While India's **refugee policy** went against its own **traditional practices**, it was found severely wanting on the Rohingya question, and seemed clueless on how to deal with the political crisis in the Maldives.
2. The arrival of an **India-friendly Ibrahim Mohamed Solih** regime in **Male** has brought much cheer, and the return of **Ranil Wickremesinghe** as Sri Lankan Prime Minister is to India's advantage too. **Nepal** has reached out to India to put an end to the acrimony that persisted through 2015 to 2017. **Bhutan, Myanmar and Bangladesh are also positively disposed** towards India, though the relationship with Pakistan continues to be testy and directionless.
3. **Lessons from the past**
 1. **India must shed its aggression** and deal with tricky situations with far more diplomatic subtlety and finesse. The manner in which it weighed down on Nepal in 2015 during the Constitution-making process is an example of how not to influence outcomes.
 2. **Meddling in the domestic politics** of neighbour countries is a recipe for disaster, even when invited to do so by one political

faction or another. Preferring one faction or regime over another is unwise in the longer term. Ex: Sri Lanka. (Preferred Sirisena initially but he again cobbled alliance with Rajapaksa).

3. Third, New Delhi must **not fail to follow up on its promises to its neighbours**. It has a terrible track record in this regard.
 4. There is **no point in competing with China** where China is at an advantage . This is especially true of regional infrastructure projects. India simply does not have the political, material or financial wherewithal to outdo China in building infrastructure. Hence **India must invest where China falls short**, especially at the level of institution-building and the use of soft power.
4. **Going forward**
1. There needs to be **better regional trading arrangements**.
 2. There is only so much that can be gained from bilateral arrangements, and there should be more attempts at forging **multilateral arrangements**, including by resurrecting SAARC.
 3. Third, India must have a **coherent and long-term vision** for the neighbourhood devoid of empty rhetoric without follow up.

India-Pakistan

1. The history of Indo-Pak Relations has been mainly a story of conflict and discord, mutual distrust and suspicion.

○ India - Pakistan

- 1) "The Kartarpur Corridor between India and Pakistan will 'open new doors' and is a 'unifier building bridges across old chasms'"
- Vice President Venkaiah Naidu

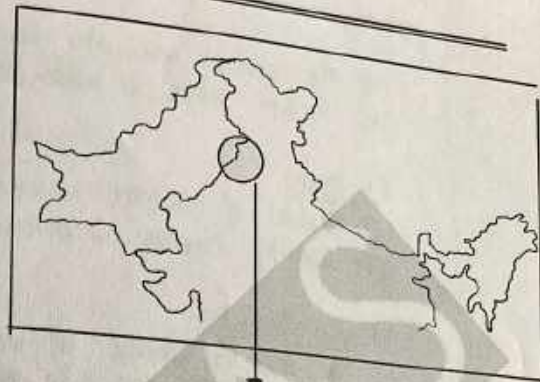

2) Kartarpur Corridor

- (i) The Pakistan-India Protocol on visits to Religious shrines of 1974 allows people to visit holy sites on either side of the border.
- (ii) Every year, the visas issued to pilgrims depends on the state of ties at that moment as it is not the embassy which decides the number of visas to be issued but the security establishment.
- (iii) The low number of visas issued sometimes becomes a cause of tension between the two countries.
- (iv) To overcome these issues a visa-free Kartarpur corridor is being built.
- (v) It is a corridor from Indian border village of Dera Baba Nanak in Punjab across the border to Ghurdwara Kartarpur sahib located on the banks of the river Ravi.
- (vi) The four lane corridor will be funded by the Centre and developed by NHAI.

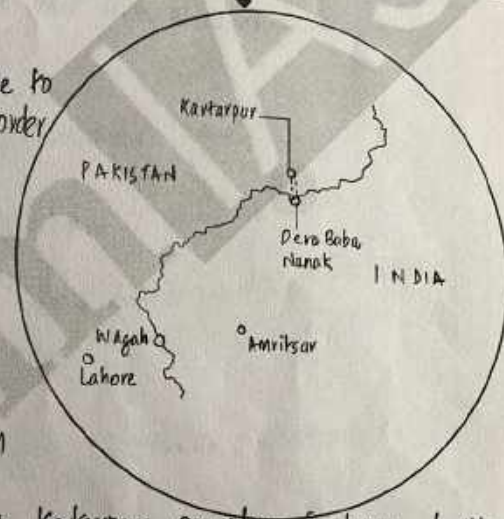

3) Significance

- (i) There was a huge demand from the Sikh community from either side of the border. so both the countries did not oppose it.
- (ii) Focus on religious tourism and humanitarian issues would help revive ties.
- (iii) The time taken for the journey of pilgrims will be cut down drastically to just 6 km.
- (iv) It is a starting point for innovative diplomacy and promote dialogue between both the countries.
- (v) This will also help to take up other similar projects. Eg for Kashmiri Pandits and Sufis of Pakistan.

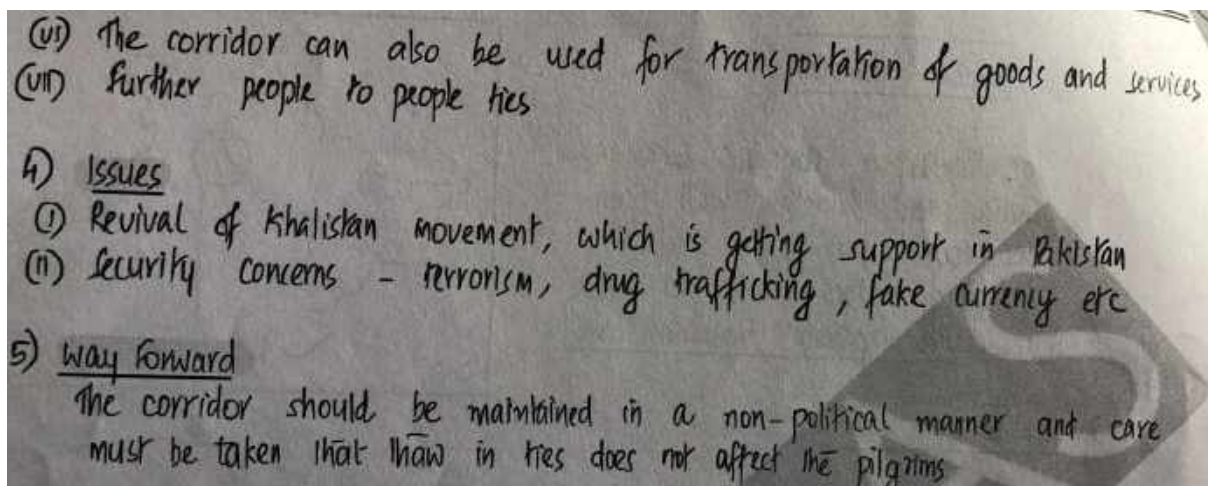

India's diplomatic pressure on Pakistan

1. **Isolating Pakistan** is difficult to achieve as it has its own relations and all weather friends like China, Saudi Arabia. But diplomatic pressure is certainly achievable.
2. **Pakistan is put in FATF black list** because of intense diplomatic pressure by India.
3. India should change the narrative in international space. **India should highlight Pakistan's internal problems** and how the civilian population are suppressed there.
4. **Give military support to Iran and Afghanistan** to mount pressure on Pakistan's western border.

India-Pakistan soft power

1. India, Pak. move towards release of civilian prisoners.
2. Kartarpur corridor.

Sir-creek issue

1. **Sir Creek is a 96 km tidal estuary** on the border of India and Pakistan. The creek, which opens up into the Arabian Sea, **divides Gujarat from Sindh province of Pakistan**. The basic cause of the Sir Creek dispute lies in the interpretation of the maritime boundary line between Kutch and Sindh.

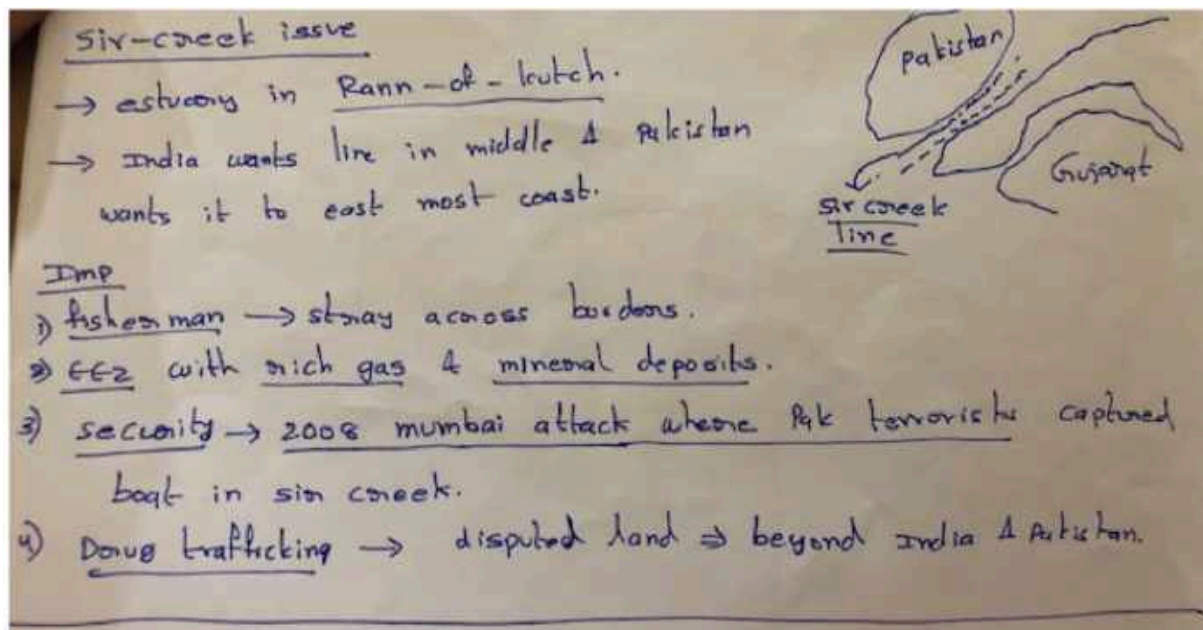

Pakistan's economic crisis

1. Pakistan is currently going through a severe balance of payments crisis, the third one in the last 10 years. Pakistan has approached the International Monetary Fund (IMF) seeking \$6 billion financial bailout for averting its balance of payments crisis.
2. **Impact on India**
 1. India might have to live with **increased Chinese influence in Pakistan**. The example of Sri Lanka's Hambantota port, which has been handed over to China as debt obligations mounted, only add to such concerns.
 2. **Unemployment** in Pakistan may rise, which leads for **breeding grounds to terrorists**. Thus India has to deal with more terror groups in Pakistan.
 3. It will **reduce trade between India and Pakistan**. Thus the relations between India and Pakistan may go sour.
 4. Rising economic woes may reduce **popularity of the Civilian governments**. This may further strengthen the power of Army.

Pakistan-Saudi Arabia Relations: Few Facts

- Pakistan has benefited enormously from Saudi Arabia – the Muslim world’s wealthiest nation – through generous financial aid, the supply of oil on a deferred payment basis and aid during crises.
 - For instance, the Saudis provided a grant of US\$10 million during the 2005 earthquake, \$170 million during the 2010-11 floods, and a \$1.5 billion grant when Pakistan faced an economic crisis in 2014.
 - Recently, Saudi Arabia has sanctioned a loan of US\$3 billion to help Pakistan overcome its financial crisis. It has also agreed to allow Pakistan to make deferred payments on oil imports amounting to US\$3 billion.
 - There are around two million Pakistani expatriates in Saudi Arabia, and they send back remittances worth over \$5 billion every year. Though the trade balance is heavily skewed in favour of Saudi Arabia, the two countries are negotiating a bilateral treaty to help correct the imbalance to some extent.
 - The stock placed by the Pakistani government on strengthening relations with Saudi Arabia is clear from the fact that newly elected PM Imran Khan has visited the Kingdom twice in three months.
 - Pakistan and Saudi Arabia have long shared strong geopolitical and economic relations. These relations have been challenged in recent years.
 - Pakistan’s stated neutrality in the war in Yemen and its failure to openly support the Saudi blockade of Qatar affected the relationship.
-
- On its part, Saudi Arabia did not support Pakistan at a crucial vote of the Financial Action Task Force to determine if Pakistan should be placed on its grey list for “strategic deficiencies” in clamping down on terrorism financing.
 - To attract Saudi interest, Pakistan floated a number of ideas, including inducting Saudi Arabia as a partner in the CPEC.
 - Since this was met with a lukewarm reception from the Kingdom, Pakistan then invited the Saudis to build an oil refinery at its Gwadar port. The Saudis have also been offered a stake in the Reko Diq copper-gold mines in Balochistan.

Afghanistan

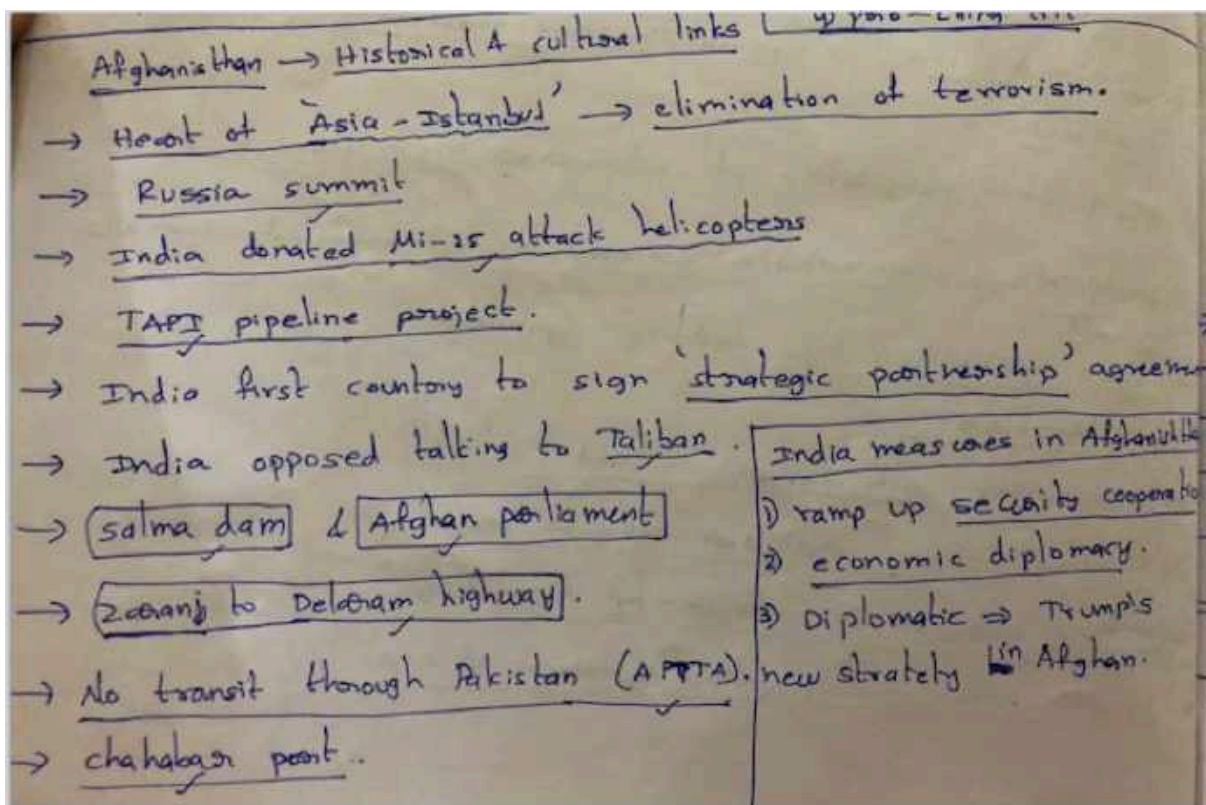

Significance of Afghanistan for India

- **Economic importance**
 - **Natural Resources:** Afghanistan has significant oil and gas reserves and has rich source of rare earth materials.
 - The massive reconstruction plans for the country offer a lot of opportunities for Indian companies for investment.
 - It has also signed the TAPI pipeline project that aims to bring natural gas from Turkmenistan through Afghanistan and Pakistan to India.
- **Security:** Stable government in Kabul is essential to reduce terror activities across south Asia also in Jammu and Kashmir. Thus, the most important goal for India remains the prevention of Pakistan from regaining its central role in Afghan affairs.
- **Gateway to energy rich central Asia:** Afghanistan is situated at crossroads between South Asia and Central Asia and South Asia and the Middle East.

Afghan Peace Process

1) "Never has a country given so much away for so little in return"
PM Modi

2) News
US President Trump announced his decision to expedite withdrawal of US forces from Afghanistan



3) US war in Afghanistan - Operation Enduring Freedom

- (i) US sent its troops to Afghanistan to fight the Taliban in 2001, as a revenge for 9/11 terrorist attacks
- (ii) Operation Enduring Freedom formally ended in December 2014. They handed over primary responsibility for the combat operations to Afghan security forces
- (iii) Trump Administration unveiled a new 'South Asia Policy' in 2017
- (iv) Trump Administration realised that as long as sanctuaries existed in Pakistan, it would be difficult to defeat Taliban. Thus it cut its funding to Pakistan.
- (v) US is wasting its resources in Afghanistan. In 12 years US had lost 2300 soldiers and spent \$105 billion in rebuilding Afghanistan

4) Implications of US withdrawal

- (1) Instability in the region
- (2) Create space for regional players like Russia, China, Iran
- (3) Pakistan may regain its primacy
- (4) It would strengthen the Taliban's hold
- (5) Threat of terrorism and security concerns for India

5) India-Afghanistan

Areas of cooperation

- (1) Developmental projects - India has committed about \$3 billion
 - India built Parliament building, Salma dam and other projects like housing, drinking water
- (2) Economic cooperation - Trade is \$400 million
 - established an air corridor

- (3) Connectivity projects : Zaranj - Delaram Highway
Rail route from Chabahar Port to Zahedan
- (4) People to people : Citizenship to Afghan minorities
: Medical tourism
- (5) Afghan Peace Process : India has always backed an Afghan led, Afghan owned and Afghan-controlled peace process

6) Challenges

- (1) India does not agree with the distinction between good and bad Taliban
- (2) Terrorist attacks on Indians and Indian embassy
- (3) Role of Pakistan
- (4) 'New Great Game'
- (5) Golden Crescent
- (6) Failure of SAARC

7) India's position w.r. to Taliban

- (1) India refused to recognise the Taliban regime of 1996-2001
- (2) India supported the 'Northern Alliance' fighting the Taliban regime in Afghanistan
- (3) India maintained that it was not going to talk with Taliban.
- (4) In the International Conference on Afghanistan in London in 2010, India said it is for the elected govt in Afghanistan to lay down the terms and conditions for negotiating with the Taliban
- (5) Tashkent Declaration of March 2018 called for direct talks with the Taliban. And India said it is ready to work towards implementation of the declaration.
- (6) India sent two formal diplomats as non-official participants at the 'marlow format' multilateral meeting that included Taliban delegates

8) Way forward

Afghanistan is entering a critical stage and must become an Indian diplomatic priority, because whatever happens in Afghanistan would affect the security situation in India and future of South Asia

Why US want to pull out

1. However, over the last 18 years, the **cumulative cost to the U.S. has been estimated at \$800 billion** on U.S. deployments and **\$105 billion in rebuilding Afghanistan**. About 2,400 U.S. troops have been killed.
2. **Taliban already control more than 50% of the country** and are getting stronger and bolder by the day. There is no doubt that the Taliban will be a major player in the politics of Afghanistan in the coming months and years.

Sri Lanka

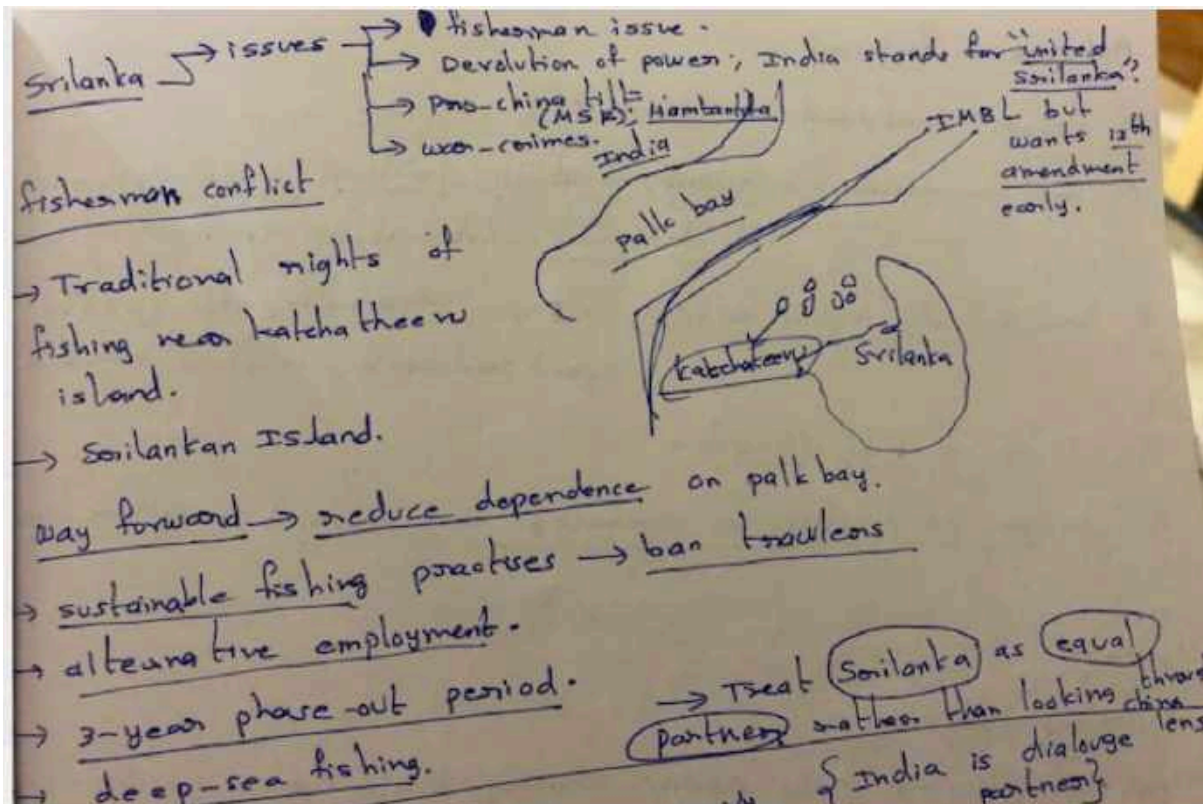

1. **India should adopt the Gujral doctrine of unilateral support** to its smaller neighbours to gain their confidence especially given China's presence. India should leverage the shared culture-history and economic complementarities and build people to people relationships to build strong relationship between two nations.

Nepal

India - Nepal

- share unique relation characterised by open borders and deep rooted people-to-people contacts.

Significance

- 1) strategic imp ⇒ buffer b/n India & China.
- 2) Internal security → link b/n Naxalits & Maoists in Nepal.
↳ open borders ⇒ drug, terrorism
- 3) Migrants to Bihar & UP
- 4) Nepali's employed.

Challenges

- 1) Nepal accused India of interfering in domestic affair.
- 2) China - Nepal relation; signed transit agreement; military exercise
- 3) Madhesi question.
- 4) Anti-India feeling & oil blockade (Nepal crisis).

India need to deal with powderke and sensitivity.

Bhutan

Bhutan

- Hydropower cooperation → run-of-river project.
- Treaty of friendship, 2007 → cooperation on issues of national interests.
- strategic imp → Doklam stand-off; buffer state.
- Chumbi valley? → 500 km from chicken's neck.
↳ Conjunction of Bhutan, China & India
- To contain insurgency in the North-east; Bhutan helped India to flush out militant groups like ULFA and NDFB
- Bhutan boycott OBOR along with India.

ASEAN

- ASEAN [East-Asian summit] → security, strategic, commercial } India is dialogue partner through ASEAN
- Look east policy in 1991
 - commerce, culture & connectivity → 3 areas of India's robust engagement with ASEAN
 - strategic partner since 2012.
 - AEP (Act East) → economic engagements + security provide
 - economically → \$3.8 trillion combined GDP; free trade agreement
 - strategically → freedom of navigation in SCS. (FTA)
 - security → piracy, trafficking.
 - Energy → Vietnam; ONGC; SCS.
 - Terrorism → strong action against state-sponsored terrorism
 - connectivity → Kaladan; Trilateral highway; under-developed NE.
 - Trade relations (RCEP); Tackling insurgency in North-east (Myanmar)
 - BIMSTEC; Mekong Ganga cooperation (MGC)

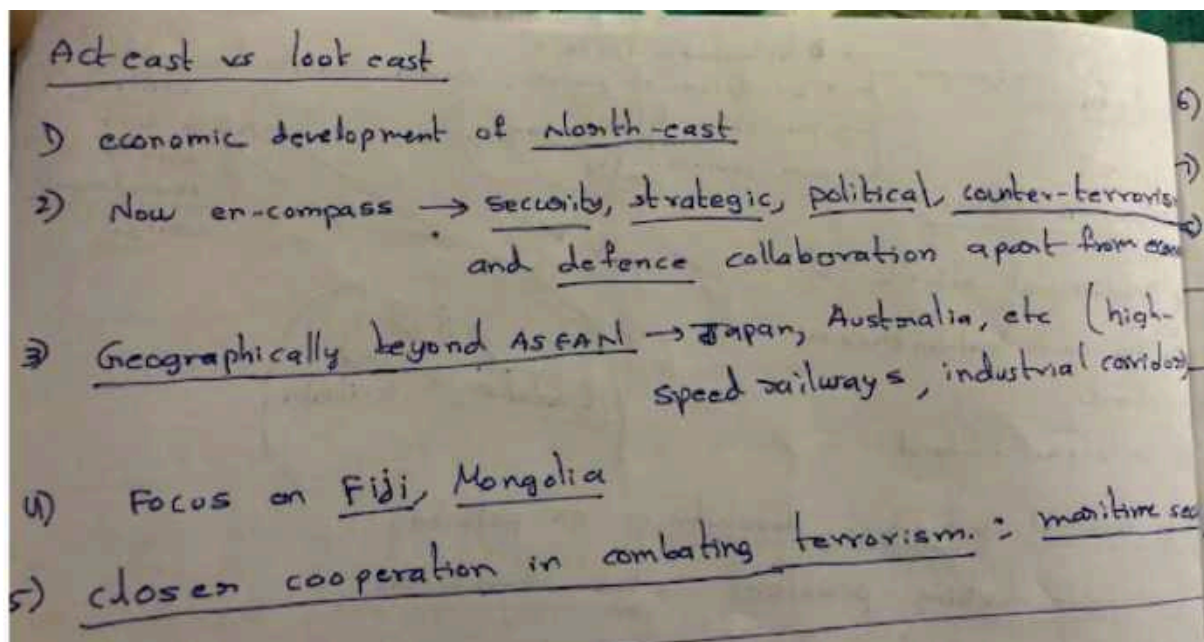

BIMSTEC

1. **Tensions between India and Pakistan** have led to **New Delhi shifting focus from SAARC to BIMSTEC**. After the Uri attack of 2016, India boycotted the SAARC summit, which was to be held in Islamabad.

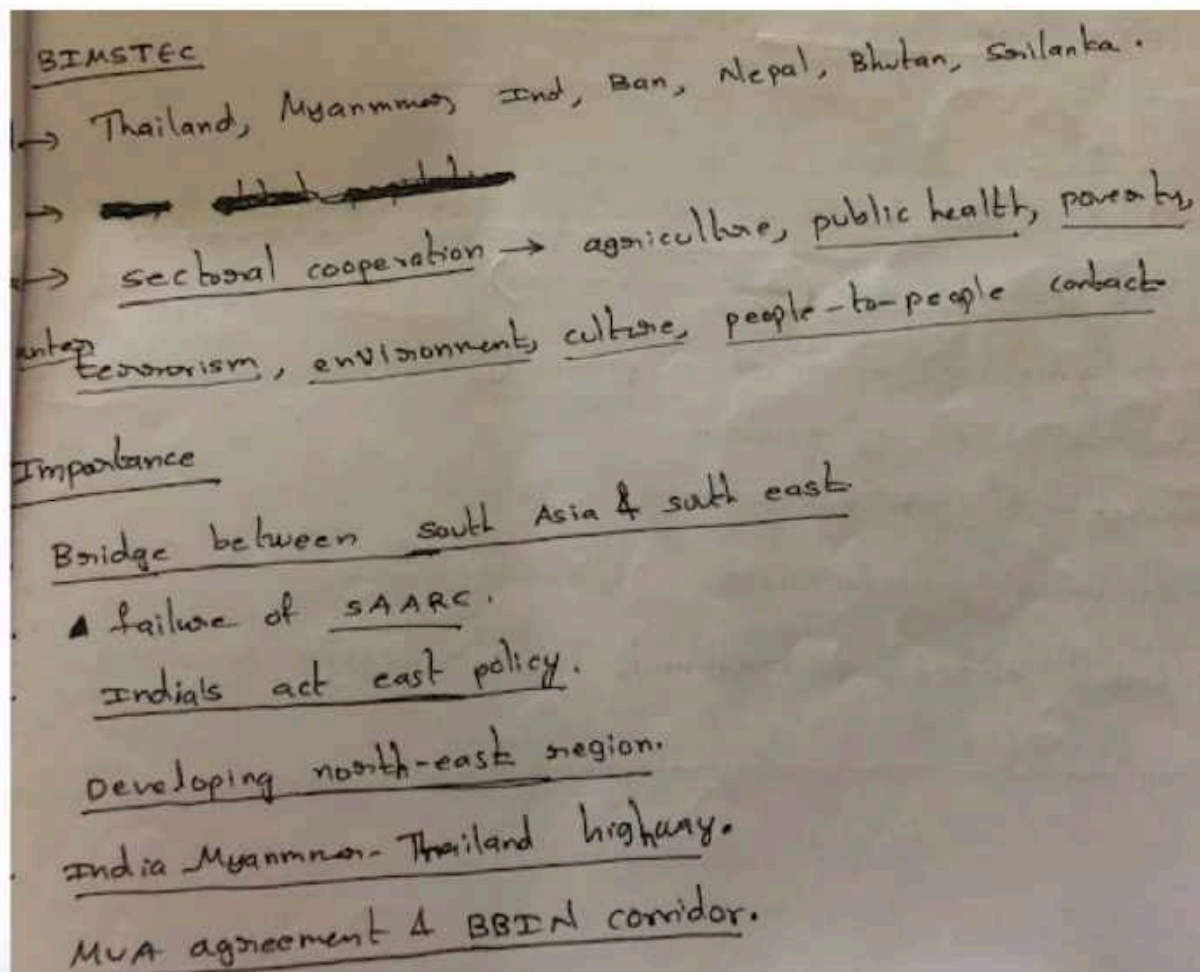

1. Strategically, BIMSTEC is a **platform to counter assertive China** in South and Southeast Asia, where it has undertaken investments through the Belt and Road initiative.
2. The **Bay of Bengal is also rich in untapped natural resources**, with reserves of gas and other seabed minerals, oil and also fishing stocks.

Potential

- regional integration → [free trade agreement negotiation].
- security cooperation.
- inclusive growth.
- untapped natural resources, hydropower potential.
- No issues like in case of Pakistan. → "issue-free relationship"

challenges

- refugee issues and ethnic tension.
- BIMSTEC suffered from lack of [resources] and proper coordination.
- [only four summit meetings] in last two decades.
- [FTA] looks like a pipe dream.

India-Myanmar

Myanmar

- 1) insurgency → cooperation
 - 2) Act east policy → only ASEAN country that shares border; buffer state.
 - 3) Energy security → oil & natural gas
 - 4) Trade & investment → market economy
 - 5) North-east → Kaladan, Tri-lateral highway
 - 6) SAARC, BIMSTEC
- challenges
- { Rohingya crisis }
 - { democracy }
 - { delay in projects }
 - { China factor }

India-Singapore

1. PM of India and Singapore reviewed the relationship and expressed satisfaction that the second review of the Comprehensive economic cooperation Agreement (CECA) has concluded.

Bilateral Trade and Investments

- Singapore is India's 10th largest bilateral trade partner (2016-17) and the 2nd largest among ASEAN countries with a share of 2.5 % and 2.6 % of overall trade of India and Singapore respectively.
- Bilateral trade expanded after the conclusion of CECA from US\$ 6.7 billion in 2004-05 to reach US\$ 17.7 billion in 2017-18.

Other Areas of Partnership

- Defence has been an area where both the countries share deepening relationship. The SIMBEX a joint naval exercise between the two countries is the symbol of the strong defence ties. India is crucial to Singapore in providing a strong defence partner that can counter and withstand the growing Chinese assertiveness.
- Science and technology and skill development have been other areas of nurturing closer ties. Singaporean companies have tied up with India's Skill Ministry for the flagship SKILL INDIA scheme. While national university of Singapore (NUS) has made several tie ups with IITs and other premier science institutes. ISRO has also helped Singapore with the launch of crucial communication satellites.
- Cultural ties have been one of the strongest pillar of the relationship between India and Singapore. Inter-governmental cooperation in culture is governed by a 1993 MOU for Cooperation in the fields of Arts, Archives and Heritage.
- ICCR and the National University of Singapore (NUS) have signed an MOU in March 2010 establishing a short-term Chair on Indian Studies at the South Asian Studies Programme, NUS.
- Indian Community has a strong presence in Singapore. Ethnic Indians constitute about 9.1 % or around 3.5 lakhs of the resident population of 3.9 million in Singapore.

RCEP

1. RCEP is a proposed free trade agreement (FTA) between the 10 ASEAN countries and its six FTA partners. 16 RCEP member states accounts for population of 3.4 billion people with 38% of the world's GDP and 29% of world trade.
2. The negotiations for this mega trade deal were formally launched at 2012 ASEAN Summit in Cambodia. It aims to cover goods, services, investments, economic and technical cooperation, competition and intellectual property rights under its ambit.

Progress In Singapore Negotiation

- **Substantial Progress:** The Ministers acknowledged the good progress made in the negotiations so far with successful conclusion of 5 chapters this year alone, taking the total to 7 chapters, namely (i) Economic and Technical Cooperation (ii) Small and Medium Enterprises (iii) Customs Procedures and Trade Facilitation (iv) Government Procurement (v) Institutional Provisions (vi) Standards, Technical Regulations and Conformity Assessment Procedures (STRACAP); and (vii) Sanitary and Phytosanitary (SPS).
- **India's Gain:** India has managed to obtain balanced outcomes in the application of the Dispute Settlement Mechanism in both STRACAP and SPS negotiations. However, India showed flexibility on the principle of 'consensus' in the Institutional Provisions Chapter to help its successful conclusion.

India's Concern

- **Impact Local Manufacturing:** There is concern across ministries that joining the accord could severely dent local manufacturing and jobs.
- **Chinese Goods May Flood Indian Market:** China's \$60-billion trade surplus with India will swell even further as it floods the market with cheap goods at zero tariff.
- **Impact On Sensitive Items Due To Tariff Cuts:** Also ASEAN's aggressive push to dismantle tariffs on about 90-92 % items and reduce tariffs to below 5 % on an additional 7 % of items is equally worrying for India; it would expose sensitive items, including farm and dairy goods, automobiles and steel products, to tariff cuts.
- **Focused More On Goods Rather Than Services:** India, however, feels while most RCEP members want New Delhi to commit more to further liberalize its goods trade, they are reluctant to offer anything substantial in return in services trade, especially on unrestricted movement of skilled professionals that is of immense interest to India. India has a trade deficit with as many as 10 RCEP countries, including China, South Korea and Australia, among others. It has so far
- **Loss Of Tax Revenue:** Moreover, according to a 2016 estimate by the Finance Ministry, India could lose tax revenue of Rs 75,733 crore a year, if it scraps tariff on merchandise imports entirely, if it were emulate zero duty model over a period of time.
- **Some Suggest That India Should Look For Alternative:** There is a view in some quarters of the government that India should instead look at concluding trade pacts separately with Australia and New Zealand.
- **Contentions in the Investment Sector:** In the investment chapter too, there are contentious areas such as liberalizing based on a negative list (wherein all items are to be included except those specifically mentioned in a list) and the inclusion of an Investor State Dispute Settlement Mechanism. This could lead to India getting involved in costly legal suits filed against it by corporates.

Changing Tack



Nuclear disarmament

Nuclear disarmament

→ Almost 16000 nuclear weapons; Apart from ~~USA~~ ^{US}; India, Pak, ~~China~~ ^{China}, ~~Israel~~ ^{Israel}, ~~Iran~~ ^{Iran}, ~~Korea~~ ^{Korea} → Nuclear weapons

Reasons to disarm

- 1) strategic excuse of deterrence is not true in multi-polar world.
- 2) Economically → divert funds from social programmes (health, edu)
- 3) environmental destruction → all complex forms
- 4) security concerns → one single event can result in full blown dt war
- 5) Humanitarian issues → catastrophic for humans
- 6) Nuclear terrorism → ^{weapons in} politically unstable countries like Pakistan can fall into terrorist hands.

Bilateral exercises

- Bilateral military exercises → Malabar, ^(Nepal) Surya Kiran, SIMBEX, etc
- 1) confidence building measures → ↑ trust
 - 2) promote bilateral army-to-army relations → understand skills, procedures, overcome language barriers, etc
 - 3) anti-piracy, disaster relief.
 - 4) strategic signalling → Malabar exercise
 - 5) Nation's soft power → brotherhood
 - 6) spirit of bonding & friendship →

TIR convention

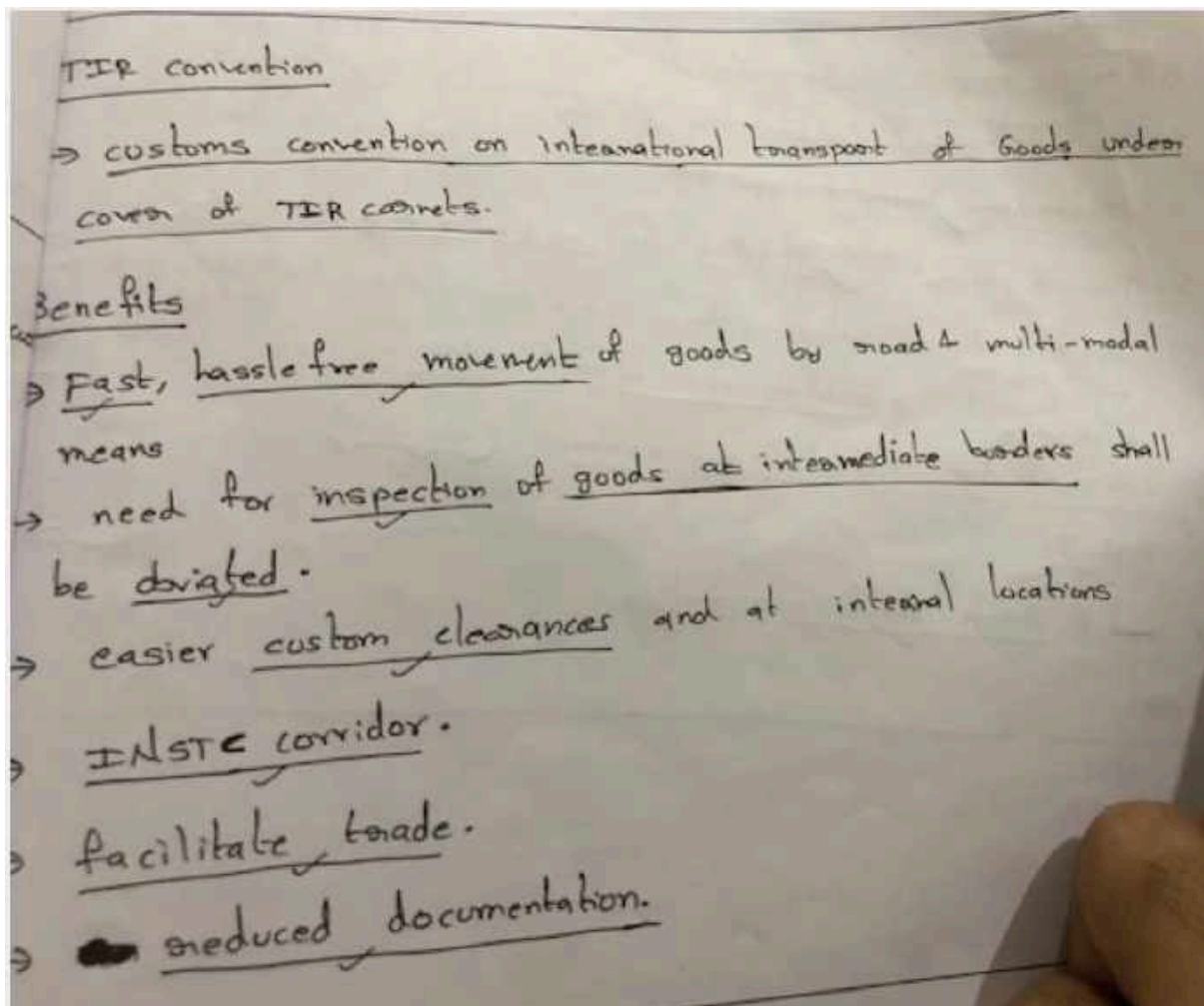

Global commons

1. The "Global Commons" refers to **resource domains** or **areas that lie outside of the political reach** of any one nation State. Thus international law identifies four global commons namely: the **High Seas**; the **Atmosphere**; **Antarctica** and the **Outer Space**.
2. **Significance of global common**
 1. According to UNEP, a **third of the global population** depends on "Commons" for their survival.
 2. Preserving Global common acts plays a pivotal role in **attaining the sustainable development goals (SDGs)**.
3. **Concerns regarding global commons**
 1. Over exploitation of resources and **domination by private players** acts as threat to global commons.
 2. Withdrawal of **Japan** from **International whaling commission**

(IWC) is recent example which pose threat to ecosystems in Antarctica, due to hunting of whales.

4. **Outer space treaty, 1967**

1. The **exploration and use of outer space** shall be carried out for the **benefit and in the interests of all countries** and shall be the province of all mankind.
2. Outer space shall be **free for exploration and use by all States**.
3. **Outer space is not subject to national appropriation** by claim of sovereignty, by means of use or occupation, or by any other means.
4. **States shall not place nuclear weapons** or other weapons of mass destruction in orbit or on celestial bodies or station them in outer space in any other manner.
5. The Moon and other celestial bodies shall be used exclusively for **peaceful purposes**.
6. **Astronauts** shall be **regarded as the envoys of mankind**.
7. **States shall be liable** for damage caused by their space objects.
8. **States shall avoid harmful contamination** of space and celestial bodies.