

12ACB SERIES UNITS

The 12ACB is a residential split-system condensing unit. The series is designed for use with expansion valves (TXV). All 12ACB units utilize scroll compressors.

Information contained in this manual is intended for use by qualified service technicians only. All specifications are subject to change.

This manual is divided into sections which discuss the major components, refrigerant system, charging procedure, maintenance and operation sequence.

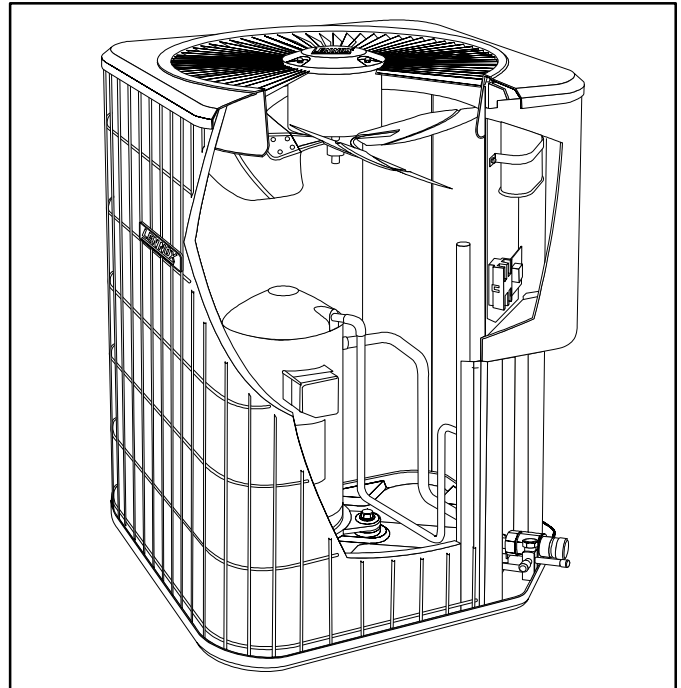

I - UNIT INFORMATION

12ACB condensing units are available in 2, 2 -1/2, 3, 3 -1/2, 4 and 5 ton capacities. All major components (indoor blower and coil) must be matched according to Lennox recommendations for the compressor to be covered under warranty. Refer to the Engineering Handbook for approved system matchups.

SPECIFICATIONS

Model No.		12ACB24	12ACB30	12ACB36	
Condenser Coil	Net face area - sq. ft. (m ²)	Outer coil	-1 — 15.21 (1.41) -2 — 5.11 (1.40)	-1 — 15.21 (1.41) -2 — 15.11 (1.40)	-1 — 15.21 (1.41) -2 — 15.11 (1.40)
		Inner coil	-1 — 5.44 (0.51) -2 — 5.40 (0.50)	-1 — 14.50 (1.35) -2 — 14.40 (1.33)	-1 — 14.50 (1.35) -2 — 14.40 (1.33)
	Tube diameter — in. (mm) & no. of rows		5/16 (8) — 1.37	5/16 (8) — 2	5/16 (8) — 2
	Fins per inch (m)		22 (866)	22 (866)	22 (866)
Condenser Fan	Diameter — in. (mm) & no. of blades		18 (457) — 3	18 (457) — 4	18 (457) — 4
	Motor hp (W)		1/6 (124)	1/6 (124)	1/6 (124)
	Cfm (L/s)		2500 (1180)	2450 (1155)	2450 (1155)
	Rpm		1100	1100	1100
	Watts		200	200	200
*Refrigerant charge furnished (HCFC-22)		-1 — 5 lbs. 8 oz. (2.49 kg) -2 — 5 lbs. 0 oz. (2.26 kg)	-1 — 7 lbs. 3 oz. (3.26 kg) -2 — 6 lbs. 8 oz. (2.95 kg)	-1 — 7 lbs. 4 oz. (3.29 kg) -2 — 6 lbs. 10 oz. (3.0 kg)	
Liquid line — in. (mm) o.d. connection (sweat)		3/8 (9.5)	3/8 (9.5)	3/8 (9.5)	
Suction line — in. (mm) o.d. connection (sweat)		3/4 (19.1)	3/4 (19.1)	7/8 (22.2)	
Shipping weight — lbs. (kg) 1 package		155 (70)	175 (79)	180 (187)	

*Refrigerant charge sufficient for 25 ft. (7.6 m) length of refrigerant lines.

SPECIFICATIONS (continued)

Model No.		12ACB42	12ACB48	12ACB60	
Condenser Coil	Net face area - sq. ft. (m ²)	Outer coil	-1 — 15.21 (1.41) -2 — 15.11 (1.40)	21.11 (1.96)	21.11 (1.96)
		Inner coil	-1 — 14.50 (1.35) -2 — 14.40 (1.33)	20.31 (1.89)	20.31 (1.89)
	Tube diameter — in. (mm) & no. of rows		5/16 (8) — 2	5/16 (8) — 2	5/16 (8) — 2
	Fins per inch (m)		22 (866)	22 (866)	22 (866)
Condenser Fan	Diameter — in. (mm) & no. of blades		18 (457) — 4	22 (559) — 4	22 (559) — 4
	Motor hp (W)		1/3 (249)	1/3 (249)	1/3 (249)
	Cfm (L/s)		2930 (1385)	3890 (1835)	3890 (1835)
	Rpm		1100	1085	1085
	Watts		310	375	375
*Refrigerant charge furnished (HCFC-22)			-1 — 7 lbs. 11 oz. (3.49 kg) -2 — 8 lbs. 0 oz. (3.6 kg)	10 lbs. 14 oz. (4.93 kg)	11 lbs. 0 oz. (4.99 kg)
Liquid line — in. (mm) o.d. connection (sweat)			3/8 (9.5)	3/8 (9.5)	3/8 (9.5)
Suction line — in. (mm) o.d. connection (sweat)			7/8 (22.2)	7/8 (22.2)	1-1/8 (28.6)
Shipping weight — lbs. (kg) 1 package			186 (84)	250 (113)	254 (115)

*Refrigerant charge sufficient for 25 ft. (7.6 m) length of refrigerant lines.

ELECTRICAL DATA

Model No.		12ACB24	12ACB30	12ACB36	12ACB42	12ACB48	12ACB60
Line voltage data — 60 hz		208/230v 1ph	208/230v 1ph	208/230v 1ph	208/230v 1ph	208/230v 1ph	208/230v 1ph
Compressor	Rated load amps	10.3	13.5	15.4	18.0	23.7	28.9
	Power factor	.96	.96	.96	.95	.96	.96
	Locked rotor amps	56.0	72.5	88.0	104.0	129.0	169.0
Condenser Coil Fan Motor	Full load amps	1.1	1.1	1.1	1.9	1.9	1.9
	Locked rotor amps	1.9	1.9	1.9	4.1	4.1	4.1
Rec. maximum fuse or circuit breaker size (amps)		20	30	35	40	50	60
*Minimum circuit ampacity		14.0	18.0	20.4	24.4	31.5	38.0

*Refer to National or Canadian Electrical Code manual to determine wire, fuse and disconnect size requirements.

NOTE — Extremes of operating range are plus 10% and minus 5% of line voltage.

II - UNIT COMPONENTS

Unit components are illustrated in figure 1.

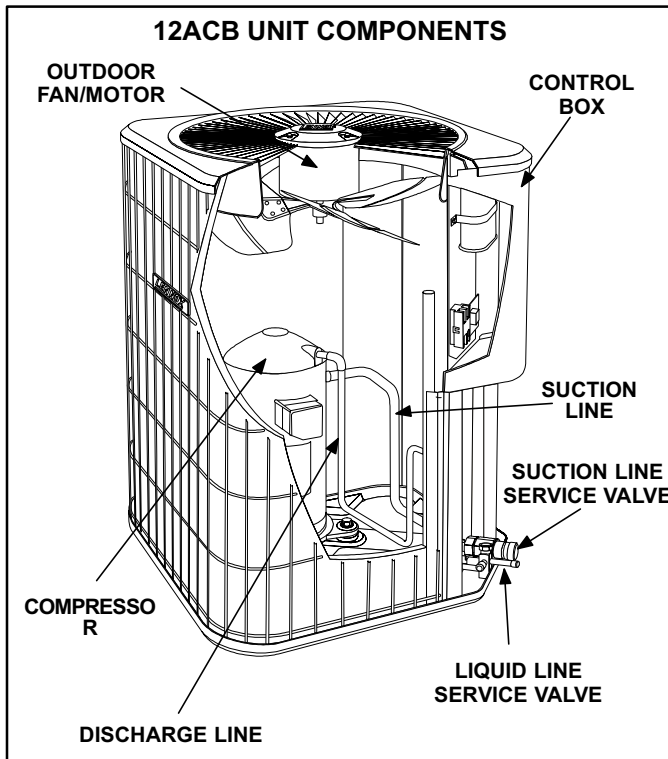

FIGURE 1

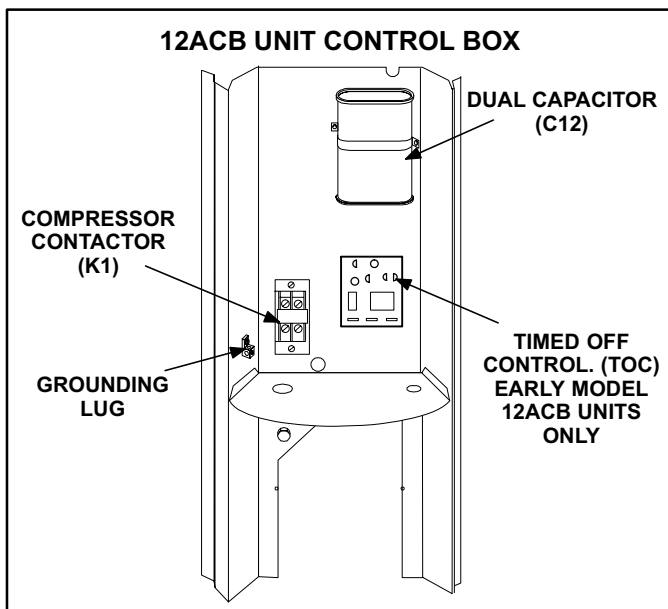

FIGURE 2

A - Control Box (Figure 2)

12ACB units are not equipped with a 24V transformer. All 24 VAC controls are powered by the indoor unit. Refer to wiring diagram.

Electrical openings are provided under the control box cover. Field thermostat wiring is made to color-coded pigtail connections.

1 - Compressor Contactor K1

The compressor is energized by a contactor located in the control box. See figure 2. Single-pole and two-pole contactors are used in 12ACB series units. See wiring diagrams for specific unit. K1 is energized by the indoor thermostat terminal Y1 (24V) when thermostat demand is present.

⚠ DANGER

Electric Shock Hazard.
May cause injury or death.



Disconnect all remote electrical power supplies before opening unit panel. Unit may have multiple power supplies.

Some units are equipped with single-pole contactors. When unit is equipped with a single-pole contactor, line voltage is present at all components (even when unit is not in operation).

2 - Dual Capacitor C12

The compressor and fan in 12ACB series units use permanent split capacitor motors. The capacitor is located inside the unit control box (see figure 2). A single "dual" capacitor (C12) is used for both the fan motor and the compressor (see unit wiring diagram). The fan side and the compressor side of the capacitor have different MFD ratings. See table 1 for dual capacitor ratings.

TABLE 1

12ACB (C12) DUAL CAPACITOR RATING			
Unit	Terminal	MFD	VAC
12ACB24	FAN	5	370
	HERM	40	
12ACB30	FAN	5	
	HERM	45	
12ACB36/42	FAN	5	
	HERM	50	
12ACB48	FAN	7.5	
	HERM	60	
12ACB60	FAN	7.5	
	HERM	80	

3 - Timed Off Control TOC

12ACB models built prior to July 1996, are equipped with a timed off control. The time delay is electrically connected between thermostat terminal Y and the compressor contactor. Between cycles, the compressor contactor is delayed for 5 minutes \pm 2 minutes. At the end of the delay, the compressor is allowed to energize. When thermostat demand is satisfied, the time delay opens the circuit to the compressor contactor coil and the compressor is de-energized.

Without the time delay it would be possible to short cycle the compressor. A scroll compressor, when short cycled, can run backward if head pressure is still high. It does not harm a scroll compressor to run backward, but it could cause a nuisance tripping of safety limits (internal overload).

For this reason, if a TOC delay should fail, it must be replaced. Do not bypass the control. Later model scroll compressors have an arrest feature which eliminates the need for the TOC. The arrest feature is internally built and mechanically prevents the compressor from turning backwards.

⚠ DANGER

DO NOT ATTEMPT TO REPAIR THIS CONTROL. UNSAFE OPERATION WILL RESULT. IF THE CONTROL IS FOUND TO BE INOPERATIVE, SIMPLY REPLACE THE ENTIRE CONTROL.

B - Compressor

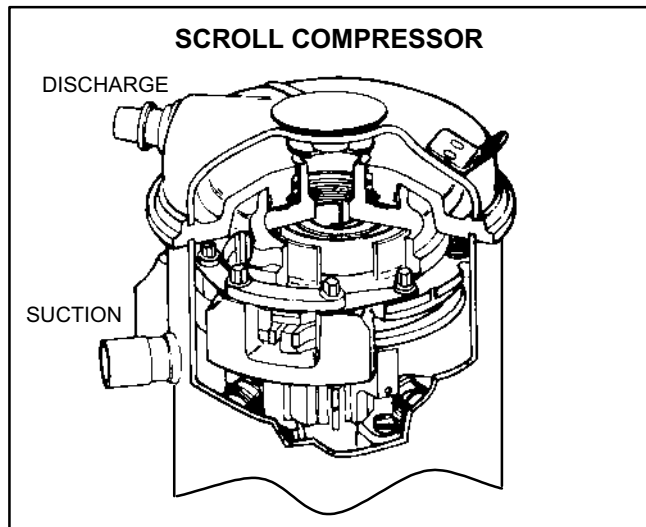

FIGURE 3

All 12ACB units utilize a scroll compressor. The scroll compressor design is simple, efficient and requires few moving parts. A cutaway diagram of the scroll compressor is shown in figure 3. The scrolls are located in the top of the compressor can and the motor is located just below. The oil level is immediately below the motor.

The scroll is a simple compression concept centered around the unique spiral shape of the scroll and its inherent properties. Figure 4 shows the basic scroll form. Two identical scrolls are mated together forming concentric spiral shapes (figure 5). One scroll remains stationary, while the other is allowed to "orbit" (figure 6). Note that the orbiting scroll does not rotate or turn but merely orbits the stationary scroll.

NOTE - During operation, the head of a scroll compressor may be hot since it is in constant contact with discharge gas.

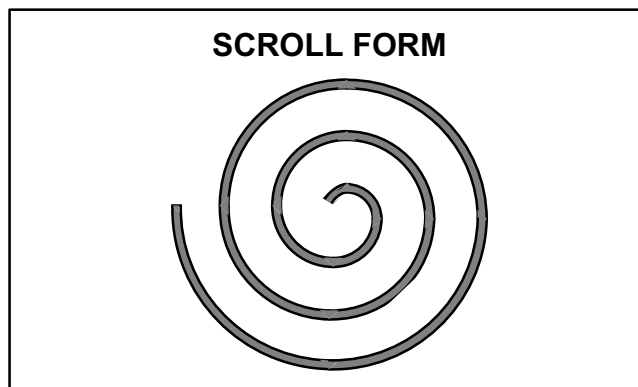

FIGURE 4

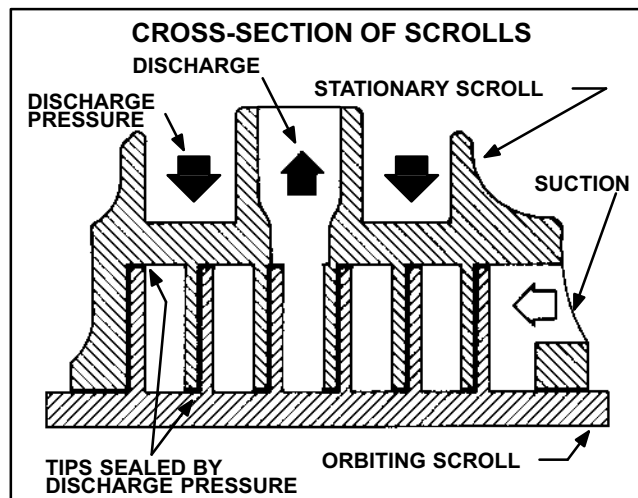

FIGURE 5

The counterclockwise orbiting scroll draws gas into the outer crescent shaped gas pocket created by the two scrolls (figure 6 - 1). The centrifugal action of the orbiting scroll seals off the flanks of the scrolls (figure 6 - 2). As the orbiting motion continues, the gas is forced toward the center of the scroll and the gas pocket becomes compressed (figure 6 - 3). When the compressed gas reaches the center, it is discharged vertically into a chamber and discharge port in the top of the compressor (figure 5). The discharge pressure forcing down on the top scroll helps seal off the upper and lower edges (tips) of the scrolls (figure 5). During a single orbit, several pockets of gas are compressed simultaneously providing smooth continuous compression.

The scroll compressor is tolerant to the effects of liquid return. If liquid enters the scrolls, the orbiting scroll is allowed to separate from the stationary scroll. The liquid is worked toward the center of the scroll and is discharged. If the compressor is replaced, conventional Lennox cleanup practices must be used.

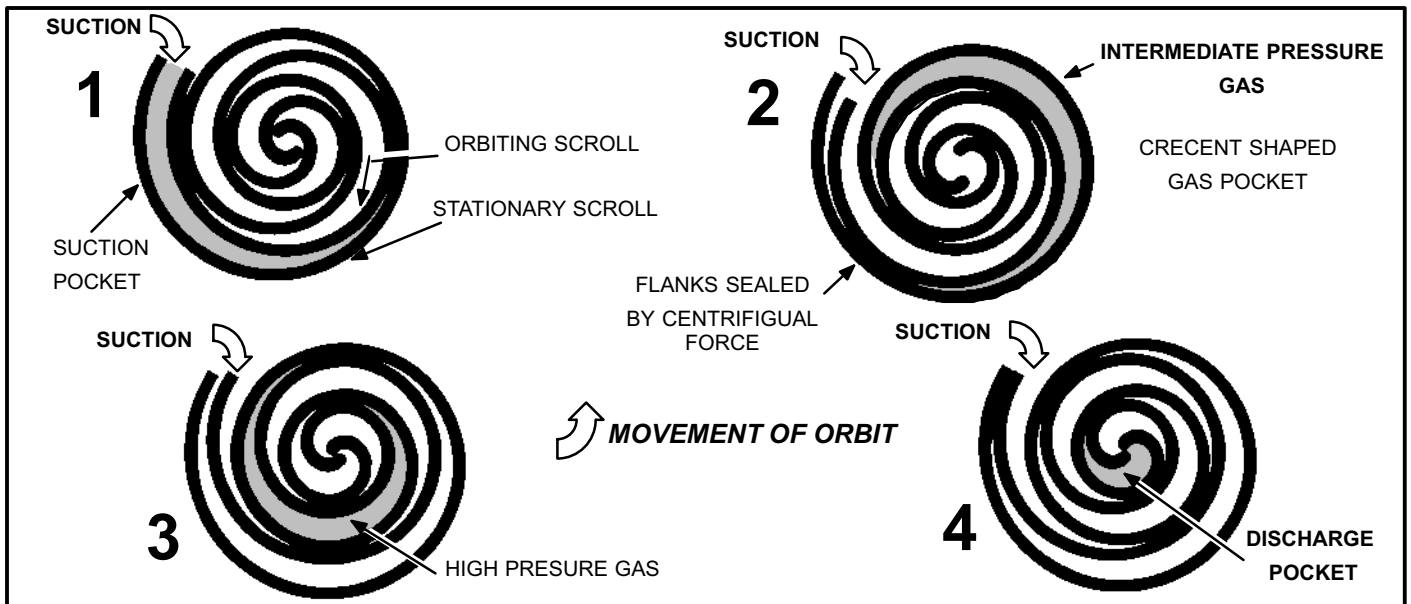

FIGURE 6

Due to its efficiency, the scroll compressor is capable of drawing a much deeper vacuum than reciprocating compressors. Deep vacuum operation can cause internal fuse arcing resulting in damaged internal parts and will result in compressor failure. Never use a scroll compressor for evacuating or “pumping-down” the system. This type of damage can be detected and will result in denial of warranty claims.

Table 2 shows the specifications of compressors used in 12ACB series units.

TABLE 2

12ACB COMPRESSOR SPECIFICATIONS						
Unit	MAN/MODEL	Voltage	Phase	LRA	RLA	Oil fl.oz.
12ACB24	COP/ZR22K3-PFV	208/230	1	56	10.3	38
12ACB30	COP/ZR28K3-PFV	208/230	1	73	13.5	38
12ACB36	COP/ZR34K3-PFV	208/230	1	88	15.4	42
12ACB42	COP/ZR40K3-PFV	208/230	1	104	18.0	42
12ACB48	COP/ZR46K3-PFV	208/230	1	129	23.7	57
12ACB60	COP/ZR57K3-PFV	208/230	1	169	28.9	50

The scroll compressor is quieter than a reciprocating compressor, however, the two compressors have much different sound characteristics. The sounds made by a scroll compressor do not affect system reliability, performance, or indicate damage.

C - Condenser Fan Motor

All units use single-phase PSC fan motors which require a run capacitor. In all units, the condenser fan is controlled by the compressor contactor.

ELECTRICAL DATA tables in this manual show specifications for condenser fans used in 12ACBs.

Access to the condenser fan motor on all units is gained by removing the seven screws securing the fan assembly.

See figure 7. The condenser fan motor is removed from the fan guard by removing the four nuts found on the top panel. Drip loops should be used in wiring when servicing motor. See figure 8 if condenser fan motor replacement is necessary.

⚠ DANGER

Make sure all power is disconnected before beginning electrical service procedures.

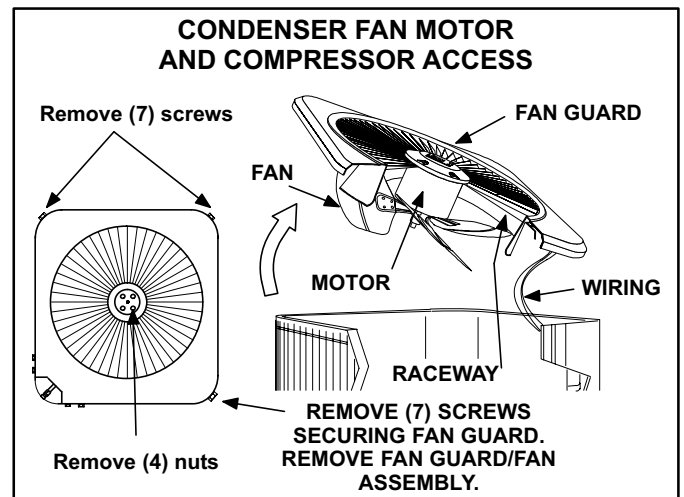

FIGURE 7

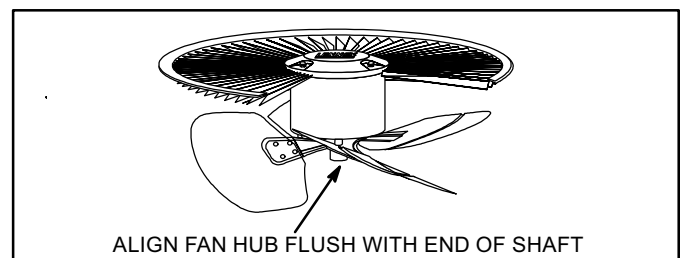

FIGURE 8

III - REFRIGERANT SYSTEM

A - Plumbing

Field refrigerant piping consists of liquid and suction lines from the condensing unit (sweat connections) to the indoor evaporator coil (flare or sweat connections). Use Lennox L10 (flare) or L15 (sweat) series line sets as shown in table 1.

TABLE 1

Condensing Unit Model No.	Line Set Model No. (L10 or L15)	Length of Lines		Liquid Line Outside Dia.		Suction Line Outside Dia.	
		ft.	m	in.	mm	in.	mm
12ACB24 12ACB30	L10-41-20 L15-41-20	20	6	3/8	9.5	3/4	19
	L10-41-30 L15-41-30	30	9				
	L10-41-40 L15-41-40	40	12				
	L10-41-50 L15-41-50	50	15				
12ACB36 12ACB42 12ACB48	L10-65-30 L15-65-30	30	9	3/8	9.5	7/8	22.2
	L10-65-40 L15-65-40	40	12				
	L10-65-50 L15-65-50	50	15				
12ACB60	*Not available			3/8	9.5	1-1/8	28.5

*Field fabricate.

The liquid and suction line service valves (figures 9 and 10) and gauge ports are accessible from outside the unit.

The valve is equipped with a service port. The service ports are used for leak testing, evacuating, charging and checking charge. A schrader valve is factory installed. A service port cap is supplied to protect the schrader valve from contamination and serve as the primary leak seal.

NOTE-Always keep valve stem caps clean.

To Access Schrader Port:

- 1 - Remove service port cap with an adjustable wrench.
- 2 - Connect gauge to the service port.
- 3 - When testing is completed, replace service port cap. Tighten finger tight, then an additional 1/6 turn.

To Open Liquid or Suction Line Service Valve:

- 1 - Remove stem cap with an adjustable wrench.
- 2 - Using service wrench and 5/16" hex head extension back the stem out counterclockwise until the valve stem just touches the retaining ring.
- 3 - Replace stem cap and tighten finger tight, then tighten an additional 1/6 turn.

⚠ DANGER

Do not attempt to backseat this valve. Attempts to backseat this valve will cause snap ring to explode from valve body under pressure of refrigerant. Personal injury and unit damage will result.

To Close Liquid or Suction Line Service Valve:

- 1 - Remove stem cap with an adjustable wrench.
- 2 - Using service wrench and 5/16" hex head extension, turn stem clockwise to seat the valve. Tighten firmly.
- 3 - Replace stem cap. Tighten finger tight, then tighten an additional 1/6 turn.

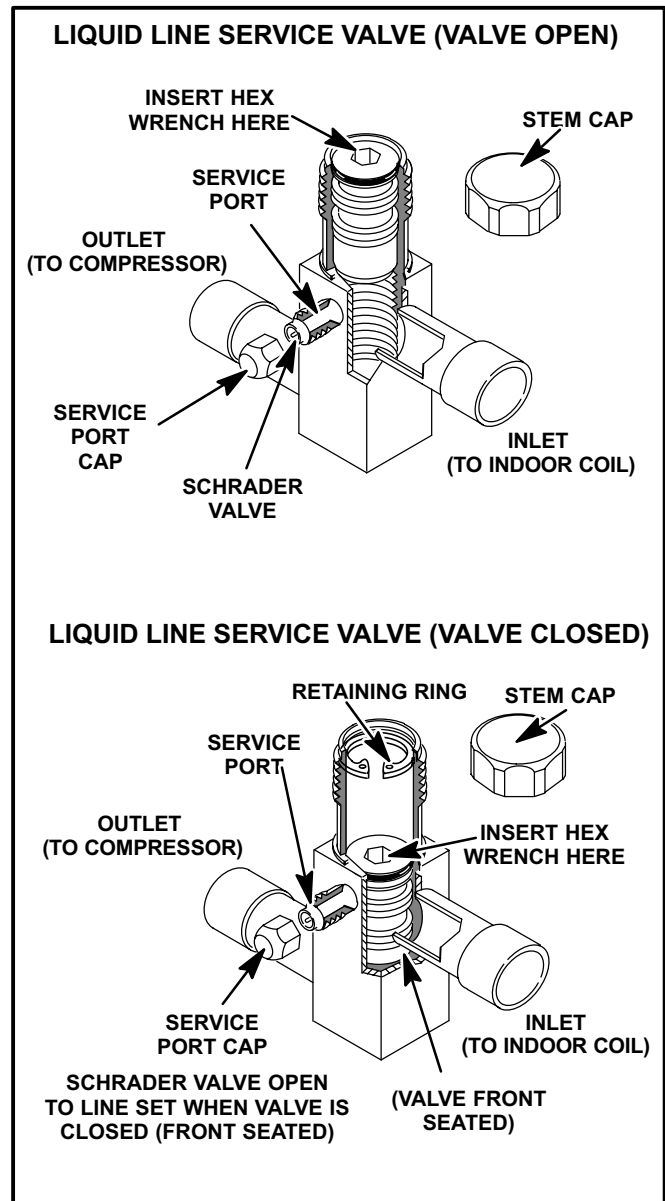

FIGURE 9

B - Service Valves

Suction Line (Ball Type) Service Valve

A ball-type full service valve is used on all 12ACB units. Valves are not rebuildable. If a valve has failed it must be replaced. A ball valve is illustrated in figure 10.

The ball valve is equipped with a service port. A schrader valve is factory installed. A service port cap is supplied to protect the schrader valve from contamination and assure a leak free seal.

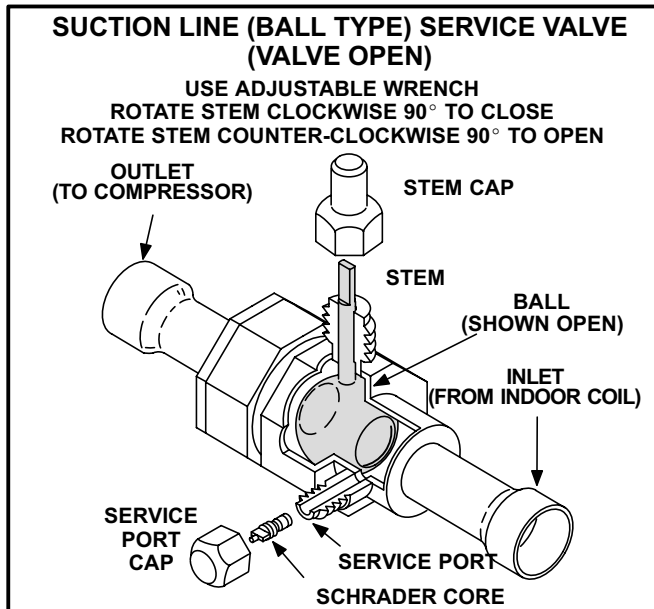

FIGURE 10

IV - CHARGING

The unit is factory-charged with the amount of R-22 refrigerant indicated on the unit rating plate. This charge is based on a matching indoor coil and outdoor coil with a 20 foot (6.1 m) line set. For varying lengths of line set, refer to table 3 for refrigerant charge adjustment. A blank space is provided on the unit rating plate to list actual field charge.

! IMPORTANT

If line length is greater than 20 feet (6.1 m) add this amount. If line length is less than 20 feet (6.1 m), subtract this amount.

TABLE 3

LIQUID LINE SET DIAMETER	Ounce per 5 foot (ml per mm) adjust from 20 foot (6.1m) line set*
1/4 in. (6 mm)	1 ounce per 5 feet (30 ml per 1524 mm)
5/16 in. (8mm)	2 ounce per 5 feet (60 ml per 1524 mm)
3/8 in. (10 mm)	3 ounce per 5 feet (90 ml per 1524 mm)

*If line set is greater than 20 ft. (6.1m) add this amount. If line set is less than 20 feet (6.1 m) subtract this amount

Units are designed for line sets up to 50 feet (15.2 m). Consult Lennox Refrigerant Piping Manual for line sets over 50 feet (15.2 m).

A - Pumping Down System

! CAUTION

Deep vacuum operation (operating compressor at 0 psig or lower) can cause internal fusite arcing resulting in a damaged or failed compressor. This type of damage will result in denial of warranty claim.

The system may be pumped down when leak checking the line set and indoor coil or making repairs to the line set or indoor coil.

- 1- Attach gauge manifold.
- 2- Front seat (close) liquid line valve.
- 3- Start outdoor unit.
- 4- Monitor suction gauge. Stop unit when 0 psig is reached.
- 5- Front seat (close) suction line valve.

B - Leak Testing (To Be Done Before Evacuating)

- 1- Attach gauge manifold and connect a drum of dry nitrogen to center port of gauge manifold.
- 2- Open high pressure valve on gauge manifold and pressurize line set and indoor coil to 150 psig (1034 kPa).
- 3- Check lines and connections for leaks.

NOTE-The preferred method is to use an electronic leak or Halide detector. Add a small amount of R22 (3 to 5 psig [20kPa to 34kPa]) then pressurize with nitrogen to 150 psig.

- 4- Release nitrogen pressure from the system, correct any leaks and recheck.

! CAUTION

When using dry nitrogen, a pressure reducing regulator must be used to prevent excessive pressure in gauge manifold, connecting hoses, and within the system. Regulator setting must not exceed 150 psig (1034 kpa). Failure to use a regulator can cause equipment failure resulting in injury.

C - Evacuating the System

- 1- Attach gauge manifold. Connect vacuum pump (with vacuum gauge) to center port of gauge manifold. With both manifold service valves open, start pump and evacuate indoor coil and refrigerant lines.

! IMPORTANT

A temperature vacuum gauge, mercury vacuum (U-tube), or thermocouple gauge should be used. The usual Bourdon tube gauges are not accurate enough in the vacuum range.

! IMPORTANT

The compressor should never be used to evacuate a refrigeration or air conditioning system.

- 2- Evacuate the system to 29 inches (737mm) vacuum. During the early stages of evacuation, it is desirable to stop the vacuum pump at least once to determine if there is a rapid loss of vacuum. A rapid loss of vacuum would indicate a leak in the system and a repeat of the leak testing section would be necessary.
- 3- After system has been evacuated to 29 inches (737mm), close gauge manifold valves to center port, stop vacuum pump and disconnect from gauge manifold. Attach an upright nitrogen drum to center port of gauge manifold and open drum valve slightly to purge line at manifold. Break vacuum in system with nitrogen pressure by opening manifold high pressure valve. Close manifold high pressure valve to center port.
- 4- Close nitrogen drum valve and disconnect from gauge manifold center port. Release nitrogen pressure from system.
- 5- Connect vacuum pump to gauge manifold center port. Evacuate system through manifold service valves until vacuum in system does not rise above .5mm of mercury absolute pressure or 500 microns within a 20-minute period after stopping vacuum pump.
- 6- After evacuation is complete, close manifold center port, and connect refrigerant drum. Pressurize system slightly with refrigerant to break vacuum.

D - Charging

If the system is completely void of refrigerant, the recommended and most accurate method of charging is to weigh the refrigerant into the unit according to the total amount shown on the unit nameplate. Also refer to the SPECIFICATIONS tables on pages 1 and 2.

If weighing facilities are not available or if unit is just low on charge, the following procedure applies.

Expansion Valve Systems

The following procedures are intended as a general guide for use with expansion valve systems only. For best results, indoor temperature should be between 70°F and 80°F (21.1°C and 26.7°C). Outdoor temperature should be 60°F (15.6°C) or above. Slight variations in charging temperature and pressure should be expected. Large variations may indicate need for further servicing.

! IMPORTANT

The following procedure requires accurate readings of ambient (outdoor) temperature, liquid temperature and liquid pressure for proper charging. Use a thermometer with accuracy of ± 2 °F (± 1.1 °C) and a pressure gauge with accuracy of ± 5 PSIG (± 34.5 kPa).

APPROACH METHOD (TXV SYSTEMS)

(Ambient Temperature of 60°F [16°C] or Above)

NOTE- It may be necessary to restrict air flow in order to reach liquid pressures in the 200-250 psig range which are required for checking charge. The indoor temperature should be above 70°F (21°C). Block equal sections of air intake panels, moving obstructions sideways until liquid pressures in the 200-250 psig range are reached.

- 1 - Connect gauge manifold. Connect an upright R-22 drum to center port of gauge manifold.
- 2 - Record outdoor air (ambient) temperature.
- 3 - Operate indoor and outdoor units in cooling mode. Allow outdoor unit to run until system pressures stabilize.
- 4 - Make sure thermometer well is filled with mineral oil before checking liquid line temperature.
- 5 - Place thermometer in well and read liquid line temperature. Liquid line temperature should be warmer than the outdoor air temperature. Table 4 shows how many degrees warmer the liquid line temperature should be.
Add refrigerant to lower liquid line temperature.
Recover refrigerant to raise the liquid line temperature.
Add refrigerant slowly as the unit approaches the correct temperature. This will allow the refrigerant to stabilize allowing the correct temperature to be read.
- 6 - When unit is properly charged, liquid line pressures should approximate those in tables 5 and 6.

**TABLE 4
APPROACH METHOD**

12ACB-1		12ACB-2	
Model	APPROACH TEMPERATURE LIQUID LINE ° F - OUTDOOR AMBIENT ° F	Model	APPROACH TEMPERATURE LIQUID LINE ° F - OUTDOOR AMBIENT ° F
12ACB24	9°F (5.0°C)	12ACB24	10°F (5.5°C)
12ACB30	12°F (6.7°C)	12ACB30	8°F (4.4°C)
12ACB36	14°F (7.8°C)	12ACB36	7°F (3.8°C)
12ACB42	13°F (7.2°C)	12ACB42	8°F (4.4°C)
12ACB48	8°F (4.4°C)		
12ACB60	11°F (6.1°C)		

**TABLE 5
12ACB-1 SERIES UNITS**

OUTDOOR COIL ENTERING AIR TEMPERATURE	NORMAL OPERATING PRESSURES*											
	12ACB24		12ACB30		12ACB36		12ACB42		12ACB48		12ACB60	
	LIQ. ± 10 PSIG	SUC. ± 10 PSIG	LIQ. ± 10 PSIG	SUC. ± 10 PSIG	LIQ. ± 10 PSIG	SUC. ± 10 PSIG	LIQ. ± 10 PSIG	SUC. ± 10 PSIG	LIQ. ± 10 PSIG	SUC. ± 10 PSIG	LIQ. ± 10 PSIG	SUC. ± 10 PSIG
65°F (18.3°C)	148	75	148	75	158	73	158	73	146	71	153	71
75°F (23.92°C)	173	76	174	76	183	74	183	74	171	73	178	73
85°F (31.2°C)	203	77	205	78	213	75	214	75	201	74	208	74
95°F (31.2°C)	233	78	236	79	247	77	245	76	231	75	240	75
105°F (31.2°C)	268	80	269	80	282	78	280	77	270	78	276	77

*These are typical pressures only. Indoor evaporator match up, indoor air quality and evaporator load will cause the pressures to vary.

**TABLE 6
12ACB-2 SERIES UNITS**

OUTDOOR COIL ENTERING AIR TEMPERATURE	NORMAL OPERATING PRESSURES*							
	12ACB24		12ACB30		12ACB36		12ACB42	
	LIQ. ±10 PSIG	SUC. ± 10 PSIG	LIQ. ±10 PSIG	SUC. ± 10 PSIG	LIQ. ±10 PSIG	SUC. ± 10 PSIG	LIQ. ±10 PSIG	SUC. ± 10 PSIG
82°F (47.2°C)	187	77	180	72	190	73	187	79
95°F (52.8°C)	226	79	219	74	229	75	229	80

*These are typical pressures only. Indoor evaporator match up, indoor air quality and evaporator load will cause the pressures to vary.

E - Oil Charge

Refer to table 2 on page 4.

V - MAINTENANCE

At the beginning of each cooling season, the system should be cleaned as follows:

A - Outdoor Unit

- 1 - Clean and inspect condenser coil. (Coil may be flushed with a water hose).
- 2 - Visually inspect all connecting lines, joints and coils for evidence of oil leaks.

NOTE-Outdoor fan motors are permanently lubricated.

B - Indoor Coil

- 1 - Clean coil if necessary.
- 2 - Check connecting lines and coil for evidence of oil leaks.
- 3 - Check condensate line and clean if necessary.

C - Indoor Unit

- 1 - Clean or change filters.
- 2 - Bearings are pre-lubricated and need no further oiling.
- 3 - Check all wiring for loose connections.
- 4 - Check for correct voltage at unit.
- 5 - Check amp-draw on blower motor.
Unit nameplate _____ Actual _____.

VI - WIRING DIAGRAMS AND SEQUENCE OF OPERATION

12ACB 2 THROUGH 5 TON OPERATING SEQUENCE

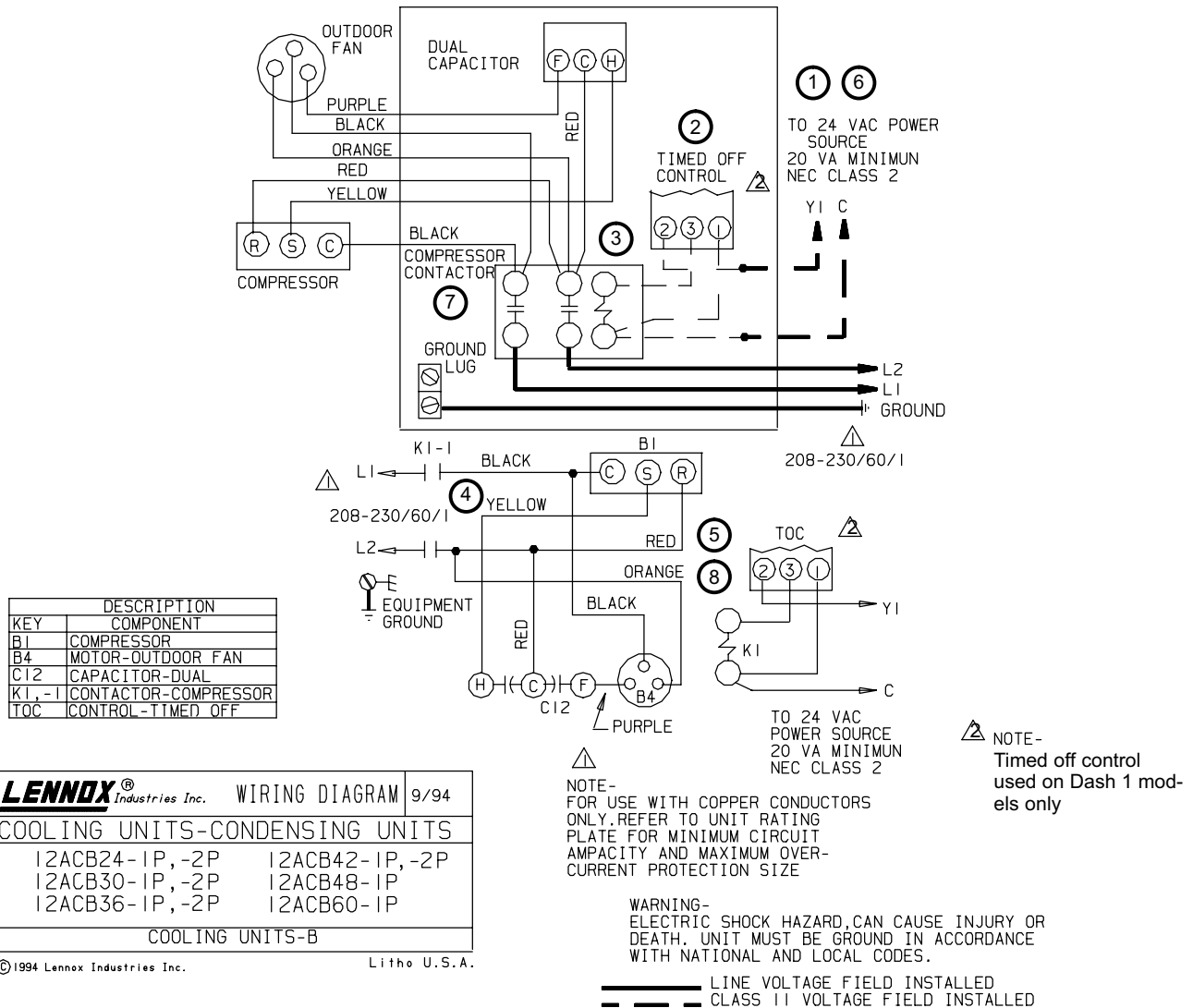

12ACB 2 - 5 TON OPERATING SEQUENCE

This is the sequence of operation for 12ACB 2 through 5 ton units. The sequence is outlined by numbered steps which correspond to circled numbers on the adjacent diagram.

NOTE- The thermostat used may be electromechanical or electronic.

NOTE- Transformer in indoor unit supplies power (24 VAC) to the thermostat and outdoor unit controls.

COOLING:

1 - Cooling demand initiates at Y1 in the thermostat.

2 - 24VAC from indoor unit (Y1) energizes the timed off control (TOC), which energizes compressor contactor K1 provided the 5 minute delay is satisfied.

NOTE- Later model units do not have the TOC. Call for cooling goes directly to contactor K1.

3 - K1-1 N.O. closes, energizing compressor (B1) and outdoor fan motor (B4).

4 - Compressor (B1) and outdoor fan motor (B4) begin immediate operation..

END OF COOLING DEMAND:

5 - Cooling demand is satisfied. Terminal Y1 is de-energized.

6 - Compressor contactor K1 is de-energized.

7 - K1-1 opens and compressor (B1) and outdoor fan motor (B4) are de-energized and stop immediately.

12ACB 2 THROUGH 3 1/2 TON OPERATING SEQUENCE

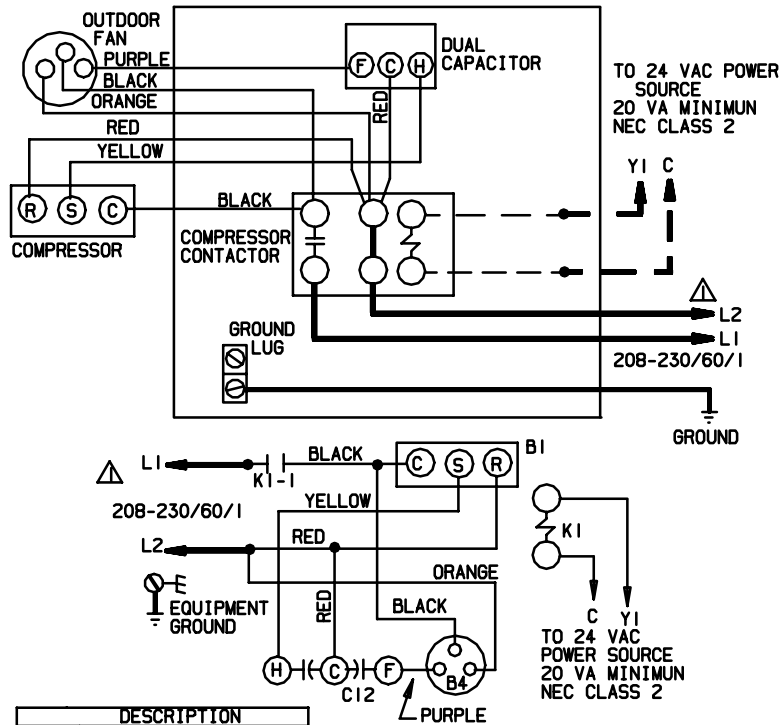

KEY	DESCRIPTION COMPONENT
B1	COMPRESSOR
B4	MOTOR-OUTDOOR FAN
C12	CAPACITOR-DUAL
K1, -1	CONTACTOR-COMPRESSOR

NOTE - FOR USE WITH COPPER CONDUCTORS ONLY. REFER TO UNIT RATING PLATE FOR MINIMUM CIRCUIT AMPACITY AND MAXIMUM OVER-CURRENT PROTECTION SIZE.

LENNOX® COOLING UNITS-CONDENSING UNITS	
12ACB24-6P	12ACB36-5P
12ACB30-5P	12ACB42-5P
0500	Supersedes Form No.
	New Form No.
	533, 470W

WARNING - ELECTRIC SHOCK HAZARD, CAN CAUSE INJURY OR DEATH. UNIT MUST BE GROUNDED IN ACCORDANCE WITH NATIONAL AND LOCAL CODES.

———— LINE VOLTAGE FIELD INSTALLED
 - - - - CLASS 11 VOLTAGE FIELD INSTALLED

12ACB 2 - 5 TON OPERATING SEQUENCE

This is the sequence of operation for 12ACB 2 through 5 ton units. The sequence is outlined by numbered steps which correspond to circled numbers on the adjacent diagram.

NOTE - The thermostat used may be electromechanical or electronic.

NOTE - Transformer in indoor unit supplies power (24 VAC) to the thermostat and outdoor unit controls.

COOLING:

- 1 - Cooling demand initiates at Y1 in the thermostat.
- 2 - 24VAC from indoor unit (Y1) energizes the timed off control (TOC), which energizes compressor contactor K1 provided the 5 minute delay is satisfied.

NOTE - Later model units do not have the TOC. Call for cooling goes directly to contactor K1.

- 3 - K1-1 N.O. closes, energizing compressor (B1) and outdoor fan motor (B4).
- 4 - Compressor (B1) and outdoor fan motor (B4) begin immediate operation..

END OF COOLING DEMAND:

- 5 - Cooling demand is satisfied. Terminal Y1 is de-energized.
- 6 - Compressor contactor K1 is de-energized.
- 7 - K1-1 opens and compressor (B1) and outdoor fan motor (B4) are de-energized and stop immediately.

12ACB 4 and 5 TON OPERATING SEQUENCE

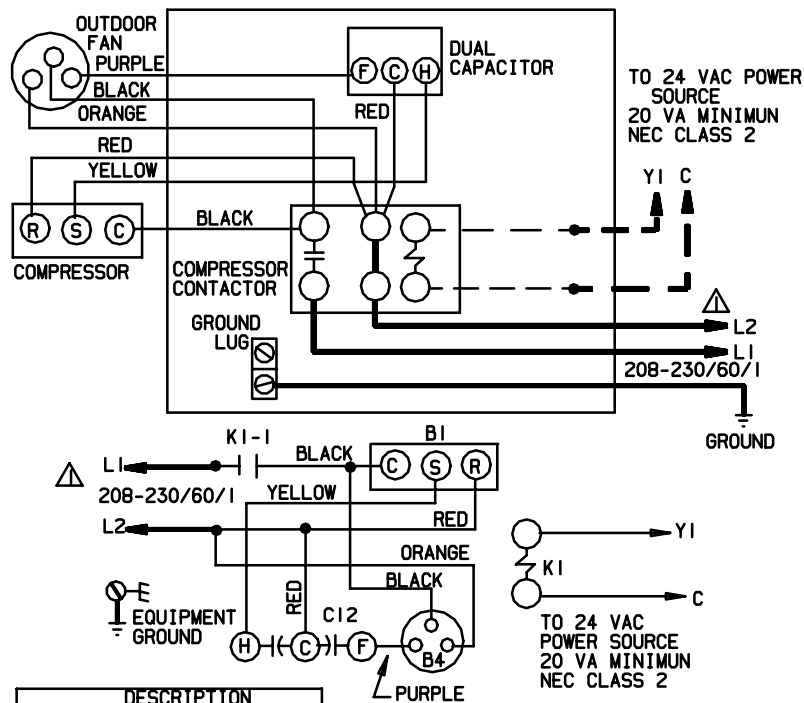

KEY	DESCRIPTION
B1	COMPRESSOR
B4	MOTOR-OUTDOOR FAN
C12	CAPACITOR-DUAL
K1, -1	CONTACTOR-COMPRESSOR

NOTE-
 △ FOR USE WITH COPPER CONDUCTORS ONLY. REFER TO UNIT RATING PLATE FOR MINIMUM CIRCUIT AMPACITY AND MAXIMUM OVER-CURRENT PROTECTION SIZE

WARNING-
 ELECTRIC SHOCK HAZARD, CAN CAUSE INJURY OR DEATH. UNIT MUST BE GROUND IN ACCORDANCE WITH NATIONAL AND LOCAL CODES.

LENNOX	COOLING UNITS- CONDENSING UNITS
	12ACB48-5P 12ACB60-4P
0500	Supersedes Form No.
	New Form No. 533,471W

©2000 Lennox Industries Inc.

Litho U.S.A.

12ACB 2 - 5 TON OPERATING SEQUENCE

This is the sequence of operation for 12ACB 2 through 5 ton units. The sequence is outlined by numbered steps which correspond to circled numbers on the adjacent diagram.

NOTE- The thermostat used may be electromechanical or electronic.

NOTE- Transformer in indoor unit supplies power (24 VAC) to the thermostat and outdoor unit controls.

COOLING:

- 1 - Cooling demand initiates at Y1 in the thermostat.
- 2 - 24VAC from indoor unit (Y1) energizes the timed off control (TOC), which energizes compressor contactor K1 provided the 5 minute delay is satisfied.

NOTE- Later model units do not have the TOC. Call for cooling goes directly to contactor K1.

- 3 - K1-1 N.O. closes, energizing compressor (B1) and outdoor fan motor (B4).
- 4 - Compressor (B1) and outdoor fan motor (B4) begin immediate operation..

END OF COOLING DEMAND:

- 5 - Cooling demand is satisfied. Terminal Y1 is de-energized.
- 6 - Compressor contactor K1 is de-energized.
- 7 - K1-1 opens and compressor (B1) and outdoor fan motor (B4) are de-energized and stop immediately.