

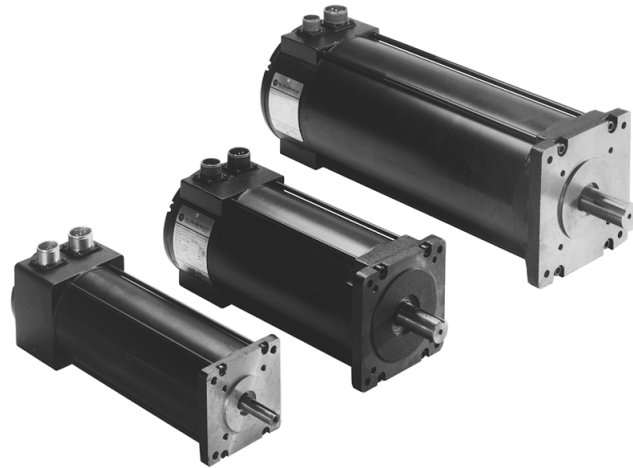

1326AB High Performance AC Servomotors

Product Data



Introduction

This publication provides detailed information about 1326AB AC Servomotors. The topics covered in this publication are listed below in order of presentation.

Basic Servomotor Description	page 2
Servomotor Options	page 2
Catalog Number Explanations	page 4
Servomotor Performance Data	page 8
Special Order Motor Information (Non-Stocked Motors)	page 17
Motor Dimensions	page 18
Motor Options	page 22
Cable Wiring Information	page 28
Servomotor Application Guide	page 30
Conversion Factors	page 44

Basic Servomotor Description

The 1326AB Servomotors are a family of high performance, three-phase, brushless AC synchronous motors designed by Allen-Bradley to meet the stringent requirements of servo system applications. This series of standard AC servomotors can be used with 1391 AC Servo Controllers. The performance parameters of these motors with selected amplifiers are listed on page 8. The typical speed-torque curves (see page 9) depict the operational envelope of these motor and controller combinations.

Each motor has the following standard features:

- Permanent magnet rotor for increased servo response.
- Three-phase sinusoidal wound stator field for direct transfer of heat to ambient, and smooth operation at low speeds.
- Brushless resolver supplies position, commutation & velocity feedback information. This also provides durability in harsh environments by not having on-board electronics in the motor. 1391 A Quad B (optional) encoder output (up to 2048 ppr) is generated via resolver feedback.
- 100% continuous rated output torque at stall (zero rpm).
- Precision balance of 0.0005" (0.0127 mm) total peak-peak displacement.
- Vertical shaft up or down mounting.
- TENV construction.
- IP65 rated (when used with the Shaft Seal option) to withstand harsh environments. Motor is dust-tight and able to withstand pulsating water jets without liquid entering the motor.
Important: 1326AB motors lose the IP 65 rating when externally mounted encoder/resolver feedback or blower packages are used.
- Normally closed thermal switch in the motor winding (rated 115V AC at 1A, 24V DC at 1A) provides thermal overload indication.
- Environmentally sealed power and feedback cable packages. Power and resolver feedback cables can be ordered as standard (flex), track (multi-flex) or extended length (ES).
- MIL spec connectors are standard.
- Ferrite magnets for cost effective performance.
- UL recognized insulation system (file # E57948).

Servomotor Options

Options available for the 1326AB include (option code designation or catalog number in parenthesis):

- Integral spring-set holding brakes with 90V DC coils (-A4, -A5, -A7) or 24V DC coils (-K4, -K5, -K7).
- Brake Power Supply (1326-MOD-BPS) converts 115V AC to the voltage needed for 90V DC brakes (-A4, -A5 and -A7).
- Shaft Oil Seal kits (1326AB-MOD-SSV-xx) for field installation of Viton shaft seals. Motor disassembly is not required.
- NEMA Inch (-11) or IEC metric flange mount (-21) with metric shafts.

Figure 1
AC Servomotor Configuration and Options

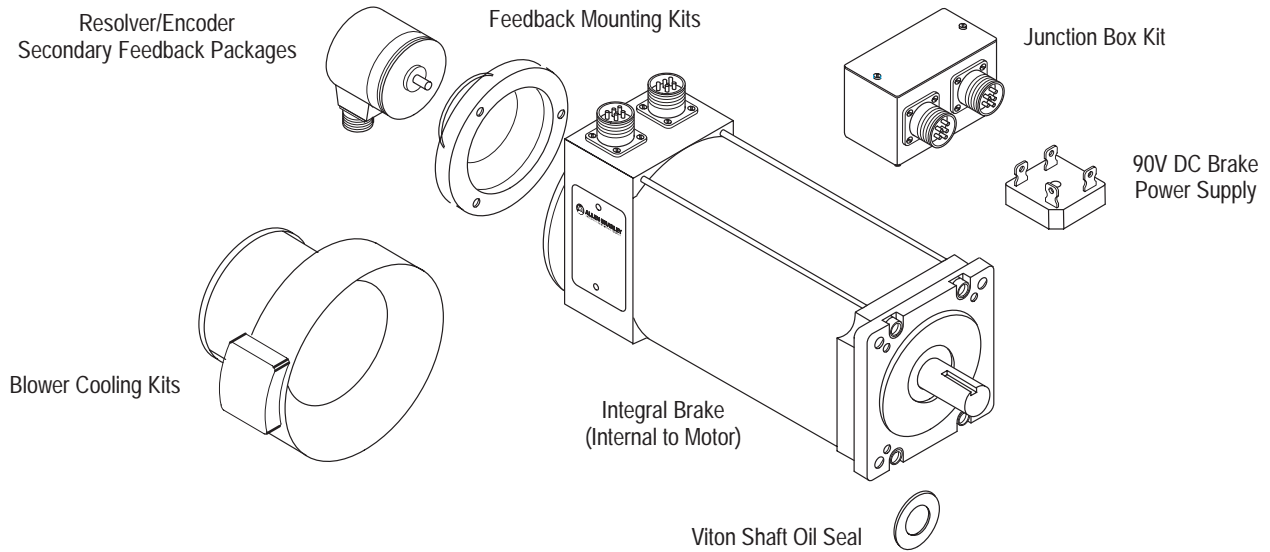

- Resolver Feedback Packages (1326AB-MOD-Vxxxx) provide 4.25” (108 mm) transducers which offer absolute/vernier or single brushless resolver feedback for use with Allen-Bradley 8600GP, IMC rack and S Class motion controllers.
- Junction Box Kit (1326AB-MOD-RJxx) available with axially mounted connectors. Connector version allows the motor connectors to be brought out axially to the motor (rather than radially) without further wiring.
- Secondary Feedback Mounting Kits (1326AB-MOD-Mx) for field installation of an Allen-Bradley Encoder (845H) or resolver. Using a 1326AB motor with a 1391B-ES (or 1391-DES) with A Quad B feedback (up to 2048 ppr) eliminates the need for encoder mounting.
- Blower Cooling Kit (1326AB-MOD-G3, G4) provides air over cooling for up to 35% more torque output on most 1326AB “C” frame motors. The kit can be field mounted on the rear of 1326AB-Cxx motors (including motors with brakes). For motors using secondary motor mounted feedback (1326AB-MOD-M60), use option “G4.”
- Cables for power (1326-CPxx . .) and feedback (1326-CFx . . - commutation, 1326-CEx . . - encoders) are available in lengths up to 100 ft .(30 m) for standard and high flex applications Power (1326ES-CPxx . .) and commutation (1326ES-CFx . .) cables over 100 ft. (30 m), up to 300 ft. (90 m) are available when using 1391B-ES or 1391-DES drives only.

All kits are supplied as motor accessories and must be specified as a separate item.

1326AB Servomotor

1326 A B - A 3 E - 11 - A4

First Position	Second Position	Third Position	Fourth Position	Fifth Position	Sixth Position	Seventh Position	Eighth Position
Bulletin Number	Type	Design	Series	Motor Length	Max. Op. Speed	Mounting & Shaft Description	Standard Options
Letter Description	Description	Description	Description	Description	RPM Code Std. ES/DES		Code Description
A	AC Servomotor PM Type	Factory use only	Sequentially lettered to designate frame diameters.	Sequentially numbered to indicate stack length within a given frame size.	B 1600 2000 C 2000 3000 E 3000 4000 G 5000 6000	11 Inch Combination Face/Flange with Keyway 21 NEMA/IEC Metric Flange with Keyway	
			Code Description			Code Description	
			A 4.25" (108 mm)			A4 72 lb.-in. (8.1 N-m) Holding Brake w/90V DC Coil.	
			B 5.88" (149 mm)			A5 120 lb.-in. (13.6 N-m) Holding Brake w/90V DC Coil.	
			C 7.63" (194 mm)			A7 400 lb.-in. (45.2 N-m) Holding Brake w/90V DC Coil.	
						K4 72 lb.-in. (8.1 N-m) Holding Brake w/24V DC Coil.	
						K5 120 lb.-in. (13.6 N-m) Holding Brake w/24V DC Coil.	
						K7 400 lb.-in. (45.2 N-m) Holding Brake w/24V DC Coil.	

Shaft Oil Seal Kit

1326AB - MOD - SS V - A 1

First Position	Second Position	Third Position	Fourth Position	Fifth Position	Sixth Position
Bulletin Number	Type	Shaft Seal	Material	Motor Series	Motor Mounting ¹
Code Description	Code Description	Letter Description	Letter Description	Letter for . . .	Number Description
MOD	Modification Kit		V Viton	A -A Series B -B Series C -C Series	1 Std. Inch 2 Metric

¹ "A" Series motors with brake must use 1326AB-MOD-SSV-A2.

Brake Power Supply Rectifier

1326 - MOD - BPS

Bulletin Number	Type	Description
Code Description	Code Description	Code Description
MOD	Modification Kit	BPS Single-phase, full-wave, screw mount rectifier with surge suppressor network. 115V AC input, for use with 90V DC brakes. ²

² Up to 4 brakes per rectifier can be used.

Feedback Coupling⁵

1326 – MOD – C1

First Position	Second Position	Third Position
Bulletin Number	Type	Coupling Size
	Code Description	Code Size – Motor Shaft to Encoder Shaft
	MOD Modification Kit	C1 3/8" to 3/8" (9.5 mm to 9.5 mm)
		C2 1/4" to 3/8" (6.4 mm to 9.5 mm)

⁵ The feedback coupling is included as standard with all Feedback Mounting Adapter Kits.

Resolver Feedback Package

1326AB – MOD – VC 1:1

First Position	Second Position	Third Position	Fourth Position
Bulletin Number	Type	Resolver Feedback Package	Gear Ratio Input:Resolver
	Code Description		
	MOD Modification Kit ⁶		

Code	Description
VC	4.25" (108 mm) feedback package with cast housing and single or vernier (dual) format with receiver (Harowe 11BRW-300-F-58A or equivalent) type resolver(s) for use with 8200, IMC 120, 121, 123.
VD	4.25" (108 mm) feedback package with cast housing and single or vernier (dual) format with transmitter (Harowe 11BRCX-300-C10/6 or equivalent) type resolver(s) for use with A-B series 8600, MAX and S Class controllers with a REC 4096 Board.

Code	Description
1:1	Single device format – 1 turn of the motor shaft to 1 turn of the resolver.
1:2	Single device format – 1 turn of the motor shaft to 2 turns of the resolver.
1:2.5	Single device format – 1 turn of the motor shaft to 2.5 turns of the resolver.
1:5	Single device format – 1 turn of the motor shaft to 5 turns of the resolver.
255	Absolute master/vernier format – 1:1 input/master, 255:256 master/vernier for IMC ¹ 120, 121, 123 only.
256	Absolute master/vernier format – 1:1 input/master, 256:255 master/vernier for 8600 series and MAX, IMC S class controls with a REC 4096 Board.
424	Absolute master/vernier format – 1:1 input/master, 424:425 master/vernier for IMC 120, 121, 123 only.
425	Absolute master/vernier format – 1:1 input/master, 425:424 master/vernier for 8600 series and MAX, IMC S class controls with a REC 4096 Board.
800	Absolute master/vernier format – 1:1 input/master, 800:801 master/vernier for IMC 120, 121, 123 only.
801	Absolute master/vernier format – 1:1 input/master, 801:800 master/vernier for 8600 series controllers (is not applicable for use with MAX/S Class controls)

⁶ Kit includes Resolver Feedback Package, mounting hardware and 3/8" to 3/8" (9.5 mm to 9.5 mm) resolver to motor mounting coupling.

Blower Mod Kit

1326AB – MOD – G3

Bulletin Number	Type		Description	
	Code	Description	Code	Motor Series
MOD	Modification Kit	G3	Rear mounted blower for the C4B and C2E motors	
		G4	"Saddle" type blower for the C4B motor	

Power and Feedback Cables

1326 – C P AB T 15

First Position		Second Position		Third Position		Fourth Position		Fifth Position		Sixth Position	
Bulletin Number		Type		Function		Motor Size Used On		Power Track Cable		Cable Length	
Letter	Description	Letter	Description	Letter	Description	Code	Type	Letter	Description	Code	Description
Blank	Standard Cable	C	Connector & Cable Assembly	P	Power Connection	AB	Series A & B (except 1326AB-B4)	T	All Series, used for high flex applications	K	Connector Kit (No Cable)
ES ⁷	Extended length cable – used with 1391B-ES and 1391-DES Only					C	Series C & 1326AB-B4	Blank	Standard Cable	15	15' (4.6 m)
				F	Commutation & Feedback Connection	U	All Series			30	30' (9.1 m)
				E	845H Encoder					50	50' (15.2 m)
				V	All 4.25" (108 mm) Resolver Packages					100	100' (30.4 m)
										150	150' (45.7 m) ⁷
										200	200' (61 m) ⁷
										250	250' (76.2 m) ⁷
										300	300' (91.4 m) ⁷

⁷ The Extended Length option is only available for 1326-CFUxx, CPABxx and CPCxx cables and can only be used with 1391B-ES and 1391-DES drives.

Servomotor Performance Data

The following section contains 1326AB performance data. Included is a Selection List detailing the performance parameters of selected amplifier/motor combinations, followed by typical speed-torque curves.

1391B Servo System Selection List ^{1,2}

Continuous Stall Torque (lb.-in./N-m)	Peak Stall Torque (lb.-in./N-m)	1391B Rated Speed (rpm)	Motor Catalog Number	Servo Amplifier Catalog Number	Amperes at Continuous Torque	Rotor Inertia (lb.-in.-s ² /kg-m ²)	Rated Output (kW)
16/1.8	48/5.4	5000	1326AB-A1G	1391B-AA15	4.5	0.004/0.0005	0.9
32/3.6	96/10.84	3000	1326AB-A2E	1391B-AA15	5.2	0.007/0.0008	1.1
48/5.4	96/10.84	3000	1326AB-A3E	1391B-AA15	7.8	0.010/0.001	1.2
93.3/10.53	186.6/21.0	3000	1326AB-B2E	1391B-AA15	15.0	0.05/0.006	2.28
102/11.5	204/23.0	3000	1326AB-B2E	1391B-AA22	16.4	0.05/0.006	2.5
140/15.8	280/31.6	3000	1326AB-B3E	1391B-AA22	22.5	0.08/0.009	3.5
153/17.3	306/34.6	3000	1326AB-B3E	1391B-AA45	24.6	0.08/0.009	3.8
210/23.7	420/47.5	3000	1326AB-C2E	1391B-AA45	33.2	0.14/0.015	5.2
310/35.0	568/64.1	3000	1326AB-C3E	1391B-AA45	49.1	0.22/0.024	7.5
420/47.4	811/91.7	2000	1326AB-C4C	1391B-AA45	46.6	0.29/0.032	7.0
420/47.4	840/94.8	1600	1326AB-C4B	1391B-AA45	38.2	0.29/0.032	5.6

1391B-ES/1391-DES Servo System Selection List ^{1,2}

Continuous Stall Torque (lb.-in./N-m)	Peak Stall Torque (lb.-in./N-m)	1391B Rated Speed (rpm)	Motor Catalog Number	Servo Amplifier Catalog Number ⁴	Amperes at Continuous Torque	Rotor Inertia (lb.-in.-s ² /kg-m ²)	Rated Output (kW)
16/1.8	48/5.4	6000	1326AB-A1G	1391B-ESAA15	4.5	0.004/0.0005	0.9
32/3.6	96/10.84	4000	1326AB-A2E	1391B-ESAA15	5.2	0.007/0.0008	1.1
48/5.4	144/16.3	4000	1326AB-A3E	1391B-ESAA15	7.8	0.010/0.001	1.6
93.3/10.53	170.7/19.3	4000	1326AB-B2E	1391B-ESAA15	15.0	0.05/0.006	3.0
102/11.5	279/31.5	4000	1326AB-B2E	1391B-ESAA22	16.4	0.05/0.006	3.3
140/15.8	280/31.6	4000	1326AB-B3E	1391B-ESAA22	22.5	0.08/0.009	4.7
153/17.3	459/51.9	4000	1326AB-B3E	1391B-ESAA45	24.6	0.08/0.009	5.1
210/23.7	569/64.3	4000	1326AB-C2E	1391B-ESAA45	33.2	0.14/0.015	6.9
310/35.0	568/64.1	4000	1326AB-C3E	1391B-ESAA45	49.1	0.22/0.024	10.0
420/47.4	811/91.7	3000	1326AB-C4C	1391B-ESAA45	46.6	0.29/0.032	9.3 ³
420/47.4	989/111.8	2000	1326AB-C4B	1391B-ESAA45	38.2	0.29/0.032	7.5

¹ All ratings are for 40° C motor ambient, 110° C case and 60° C amplifier ambient. For extended ratings at lower ambients contact Allen-Bradley.

² The motor contains two thermal switches wired in series that will open on an overtemperature condition. They are set to open at 150° C (typical) and close at 90-100° C (typical). Contacts are rated for 1A at 115V AC, 1A at 24V DC.

³ -10% line voltage maximum.

⁴ Use either 1391B-ES or 1391-DES drives.

Figure 2
Typical 1326AB Speed-Torque Curve

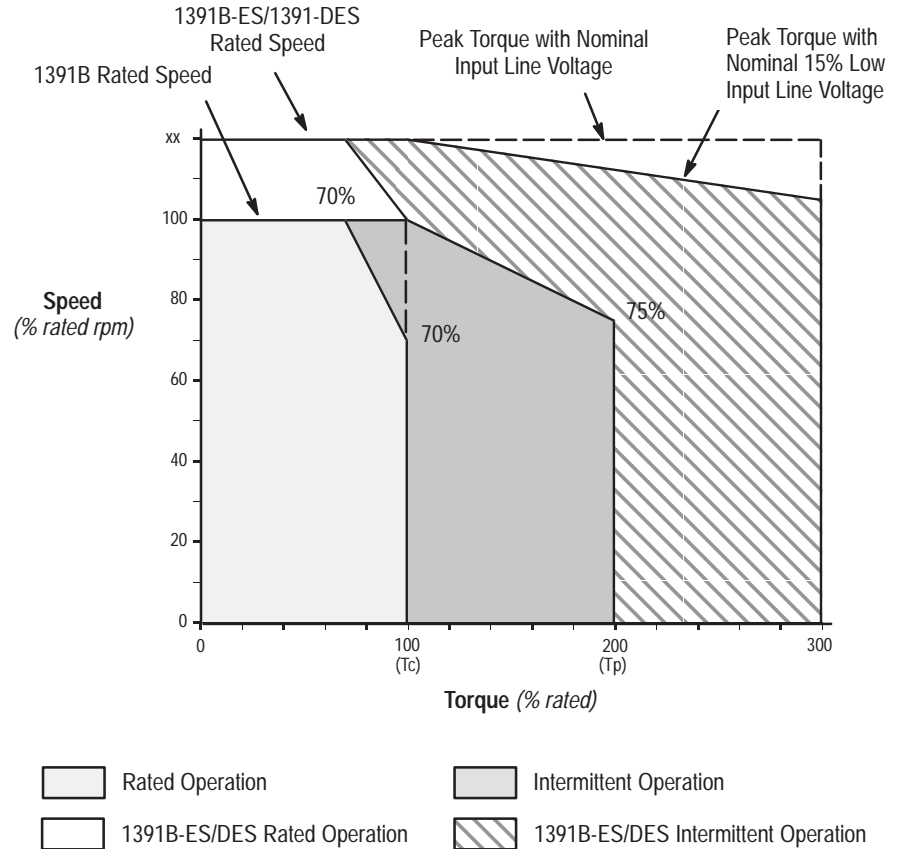

Speed-Torque Curves

Typical speed-torque curves for the standard 1326AB servomotors are contained on the following pages. Definitions of the terms used are provided below.

T_c – rated torque of motor with windings at rated temperature and an ambient of 40°C. The controller is operating in a rated ambient of 60°C.

T_p – the peak torque that can be produced by the motor/controller combination with both at rated temperature and the motor in a 40°C ambient and the controller in a 60°C ambient. Since 200% current torque peaks are common in many applications for optimal controller usage, the following curves show typical system performance. Higher peak torques are permissible where RMS torque is less than or equal to the rated torque (T_c). 1391B-ES/1391-DES operation is shown in the outer envelope and will show higher speed and 300% torque capability.

Rated Speed – the operating speed of the controller and motor combination at which a minimum of 70% of continuous rated torque (T_c) can be developed. This point is defined with the motor at 25°C and controller operating in a 60°C ambient.

Rated Operation Area – boundary of speed-torque curve where the motor and controller combination may operate on a servo basis without exceeding the RMS rating of either. See page 31 for formula details.

$$\text{RMS Torque} = \sqrt{\frac{T_{pa}^2 \times t_1 + T_{ss}^2 \times t_2 + T_{pd}^2 \times t_3 + T_r^2 \times t_4}{t_1 + t_2 + t_3 + t_4}}$$

Intermittent Operation Area – Boundary of speed-torque curve where the motor and controller combination may operate in acceleration-deceleration mode without exceeding peak rating of either, provided that the duty cycle RMS continuous torque limit is not exceeded.

Continuous Current – Rated current of motor with windings at rated temperature and an ambient of 40°C. The controller is operating in a rated ambient of 60°C.

Peak Current – The amount of current which can be applied to the motor without causing damage to the motor.

Mechanical Time Constant – Time taken by the motor to reach 63% of final speed when a step voltage is applied.

Electrical Time Constant – The time required for the motor to reach 63% of rated current.

Max. Ambient Temperature – Maximum environmental temperature in which the motor can be operated at rated loads without exceeding its insulation type temperature rise limits.

Insulation Class – Designation of operating temperature limits of the motor insulation materials.

Thermal Time Constant – Time for motor windings to reach 63% of continuous temperature rise with constant watts loss.

Torque Constant – At the stated motor temperature the amount of torque developed for one ampere of motor current.

Voltage Constant – Value of the generated voltage at a specified speed when the rotor is moved mechanically in the magnetic field.

Terminal Resistance – Winding resistance.

Inductance – Winding inductance measured by a step input of zero impedance voltage applied to the locked rotor.

Rotor Polar Moment of Inertia – Moment of inertia about the axis of rotation.

Motor Weight – Weight of the complete motor (including brake, if supplied) less the weight of options.

Balance – Compensation of rotor weight distribution to reduce vibrational resonance. Motors are factory balanced under running speeds.

Figure 3
1326AB-A1G and A2E Motor Performance Curves

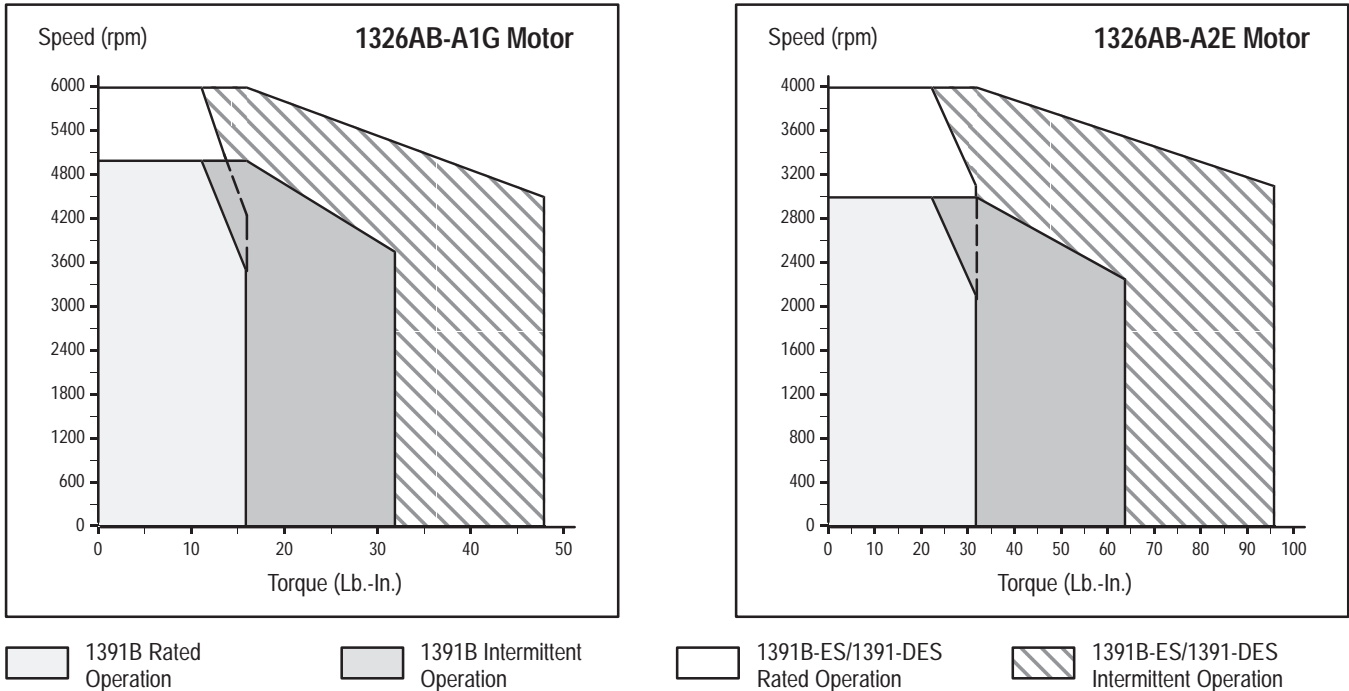

Speed-torque curves show the rated performance of the servomotor in a 40 degree C ambient. Motor is at full rated temperature. Motor windings are at 150 degrees C with a 110 degree C rise over ambient. Motor case temperature is at approximately 100 degrees C.

Important: Curves and performance data shown are for motor and amplifier combinations where amplifier rating is equal to or greater than I_c of motor

Category	Parameter	Units	1326AB-A1G	1326AB-A2E
General	Continuous Stall Torque at 40° C Ambient	lb.-in. (N-m)	16.0 (1.8)	32.0 (3.6)
	Rated Output/1391B-ES, DES Rated Output	kW	0.7/0.9	0.8/1.1
	Peak Stall Torque/1391B-ES, DES Peak Stall Torque ³	lb.-in. (N-m)	32.0 (3.6)/48.0 (5.4)	64.0 (7.2)/96.0 (10.8)
	Continuous Stall Current ³	amperes	4.5	5.2
	Peak Stall Current/1391B-ES, DES Peak Stall Current ³	amperes	9.0/13.5	10.4/15.6
	Mechanical Time Constant ³	milliseconds	10.0	9.2
	Electrical Time Constant ³	milliseconds	3.4	3.4
	Rated Speed/1391B-ES, DES Rated Speed ³	rpm	5000/6000	3000/4000
Thermal	Maximum Ambient Temperature (without derating)	degrees C	40.0	40.0
	Insulation Class		H	H
	Thermal Time Constant	minutes	23	33
Winding	Torque Constant	at 25° C lb.-in. (N-m)/A	4.18 (0.47)	7.23 (0.82)
	Voltage Constant	RMS (L-L) at 25° C volts/1000 rpm	28.5	49.5
	Terminal Resistance	ohms (L-L) at 25° C	1.9	2.89
	Inductance	mH (L-L) at 25° C	8.4	12.7
Mechanical	Rotor Polar Moment of Inertia	lb.-in.-s ² (kg-m ²)	0.004 (0.0005)	0.007 (0.0008)
	Motor Weight	lbs. (kg)	22 (10.0)	28 (12.7)
	Balance ¹	in. (mm) ²	0.0005 (0.0127)	0.0005 (0.0127)

¹ To obtain vibration velocity in inches (mm)/second use the following formula: $V_V = (D_{p-p} \times \text{rpm}) / 27.01$
 where: D_{p-p} = peak-peak displacement in in. (mm)
 V_V = Vibration velocity in in. (mm)/second
 rpm = motor speed

² peak-peak displacement

³ at 40° C

Figure 4
1326AB-A3E and B2E Motor Performance Curves

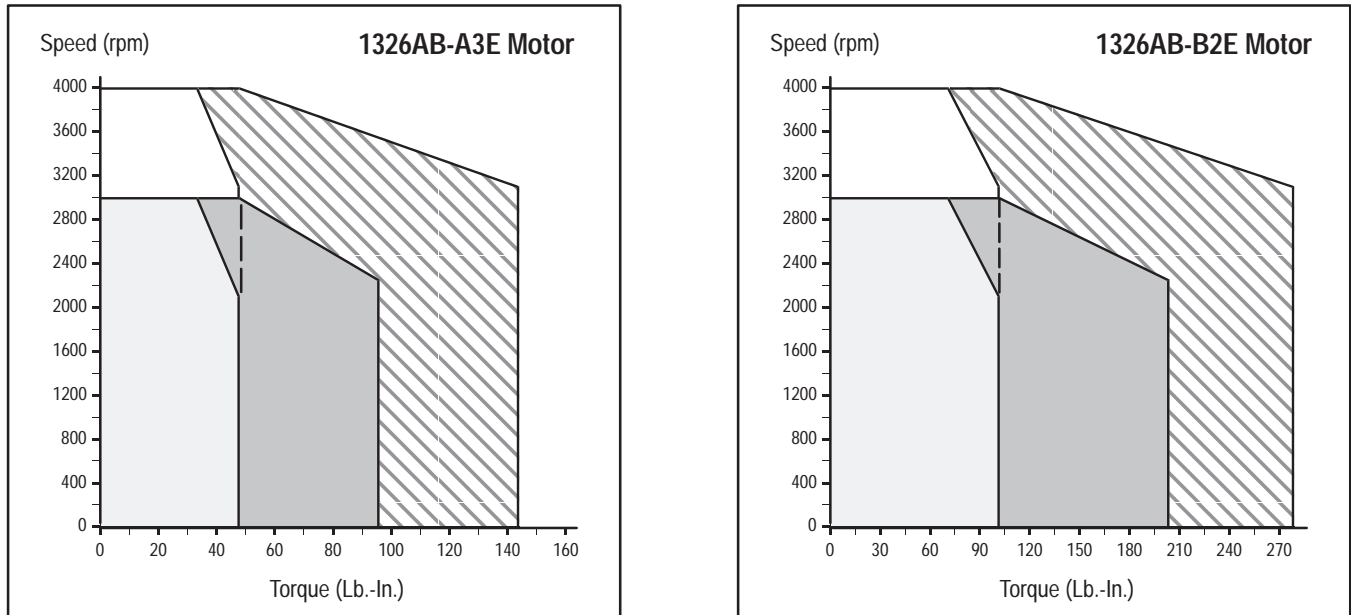

1391B Rated Operation
 1391B Intermittent Operation
 1391B-ES/1391-DES Rated Operation
 1391B-ES/1391-DES Intermittent Operation

Speed-torque curves show the rated performance of the servomotor in a 40 degree C ambient. Motor is at full rated temperature. Motor windings are at 150 degrees C with a 110 degree C rise over ambient. Motor case temperature is at approximately 100 degrees C.

Important: Curves and performance data shown are for motor and amplifier combinations where amplifier rating is equal to or greater than I_c of motor

Category	Parameter	Units	1326AB-A3E	1326AB-B2E
General	Continuous Stall Torque at 40° C Ambient	lb.-in. (N-m)	48.0 (5.4)	102.0 (11.5)
	Rated Output/1391B-ES, DES Rated Output	kW	1.2/1.6	2.5/3.3
	Peak Stall Torque/1391B-ES, DES Peak Stall Torque ³	lb.-in. (N-m)	96.0 (10.84)/144.0 (16.3)	204 (23.0)/279 (31.5)
	Continuous Stall Current ³	amperes	7.8	16.4
	Peak Stall Current/1391B-ES, DES Peak Stall Current ³	amperes	15.6/23.4	32.8/44.9
	Mechanical Time Constant ³	milliseconds	8.6	7.8
	Electrical Time Constant ³	milliseconds	3.4	7.7
	Rated Speed/1391B-ES, DES Rated Speed ³	rpm	3000/4000	3000/4000
Thermal	Maximum Ambient Temperature (without derating)	degrees C	40.0	40.0
	Insulation Class		H	H
	Thermal Time Constant	minutes	38	56
Winding	Torque Constant	at 25° C lb.-in. (N-m)/A	7.24 (0.82)	7.31 (0.83)
	Voltage Constant	RMS (L-L) at 25° C volts/1000 rpm	49.5	49.9
	Terminal Resistance	ohms (L-L) at 25° C	1.9	0.35
	Inductance	mH (L-L) at 25° C	8.4	3.52
Mechanical	Rotor Polar Moment of Inertia	lb.-in.-s ² (kg-m ²)	0.010 (0.001)	0.050 (0.006)
	Motor Weight	lbs. (kg)	37 (16.8)	61 (27.7)
	Balance ¹	in. (mm) ²	0.0005 (0.0127)	0.0005 (0.0127)

¹ To obtain vibration velocity in inches (mm)/second use the following formula: $V_V = (D_{p-p} \times \text{rpm}) / 27.01$
 where: D_{p-p} = peak-peak displacement in in. (mm)
 V_V = Vibration velocity in in. (mm)/second
 rpm = motor speed

² peak-peak displacement

³ at 40° C

Figure 5
1326AB-B3E and C2E Motor Performance Curves

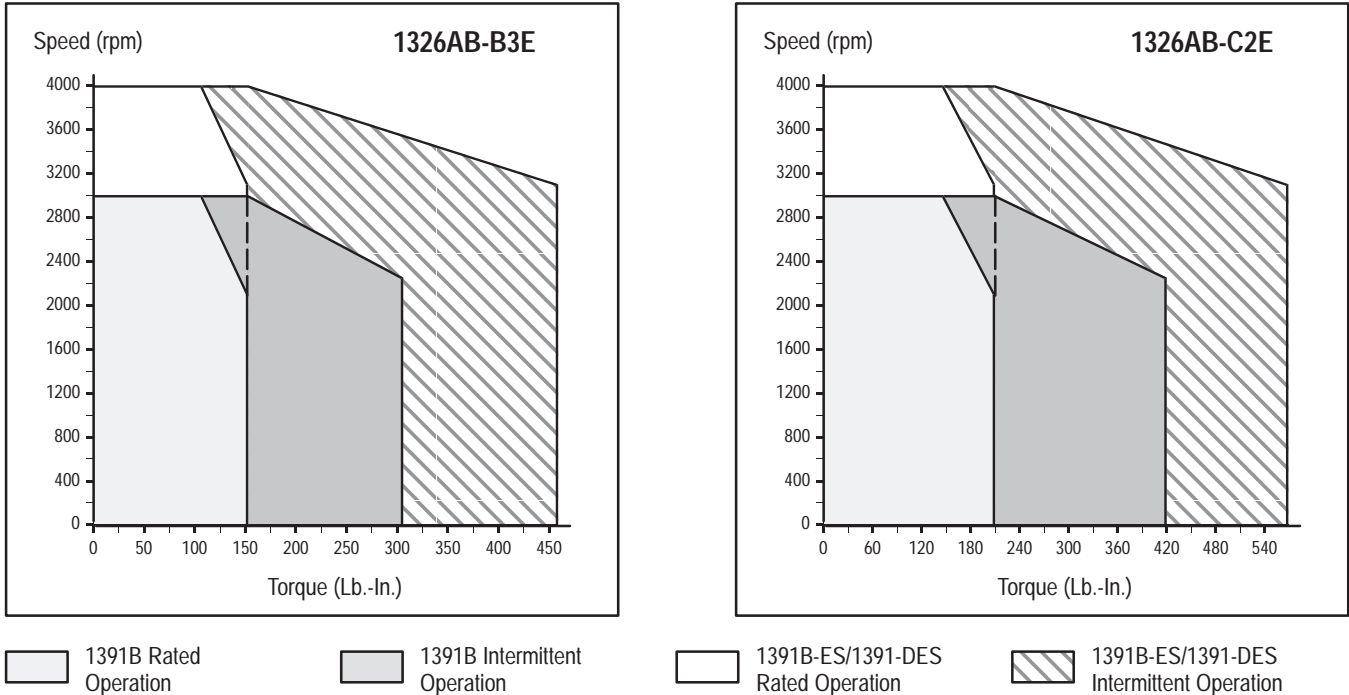

Speed-torque curves show the rated performance of the servomotor in a 40 degree C ambient. Motor is at full rated temperature. Motor windings are at 150 degrees C with a 110 degree C rise over ambient. Motor case temperature is at approximately 100 degrees C.

Important: Curves and performance data shown are for motor and amplifier combinations where amplifier rating is equal to or greater than I_c of motor

Category	Parameter	Units	1326AB-B3E	1326AB-C2E
General	Continuous Stall Torque at 40° C Ambient	lb.-in. (N-m)	153.0 (17.3)	210.0 (23.7)
	Rated Output/1391B-ES, DES Rated Output	kW	3.8/5.1	5.2/6.9
	Peak Stall Torque/1391B-ES, DES Peak Stall Torque ³	lb.-in. (N-m)	306.0 (34.6)/459.0 (51.9)	420.0 (47.4)/569.0 (64.3)
	Continuous Stall Current ³	amperes	24.6	33.2
	Peak Stall Current/1391B-ES, DES Peak Stall Current ³	amperes	49.2/73.8	66.4/90
	Mechanical Time Constant ³	milliseconds	8.6	5.3
	Electrical Time Constant ³	milliseconds	7.4	13.1
	Rated Speed/1391B-ES, DES Rated Speed ³	rpm	3000/4000	3000/4000
Thermal	Maximum Ambient Temperature (without derating)	degrees C	40.0	40.0
	Insulation Class		H	H
	Thermal Time Constant	minutes	66	71
Winding	Torque Constant	at 25° C lb.-in. (N-m)/A	7.3 (0.82)	7.44 (0.84)
	Voltage Constant	RMS (L-L) at 25° C volts/1000 rpm	49.9	50.5
	Terminal Resistance	ohms (L-L) at 25° C ohms	0.234	0.088
	Inductance	mH (L-L) at 25° C millihenry	2.35	1.5
Mechanical	Rotor Polar Moment of Inertia	lb.-in.-s ² (kg-m ²)	0.080 (0.009)	0.140 (0.015)
	Motor Weight	lbs. (kg)	76 (34.5)	102 (46.3)
	Balance ¹	in. (mm) ²	0.0005 (0.0127)	0.0005 (0.0127)

¹ To obtain vibration velocity in inches (mm)/second use the following formula: $V_V = (D_{p-p} \times \text{rpm}) / 27.01$
 where: D_{p-p} = peak-peak displacement in in. (mm)
 V_V = Vibration velocity in in. (mm)/second
 rpm = motor speed

² peak-peak displacement

³ at 40° C

Figure 6
1326AB-C3E and C4C Motor Performance Curves

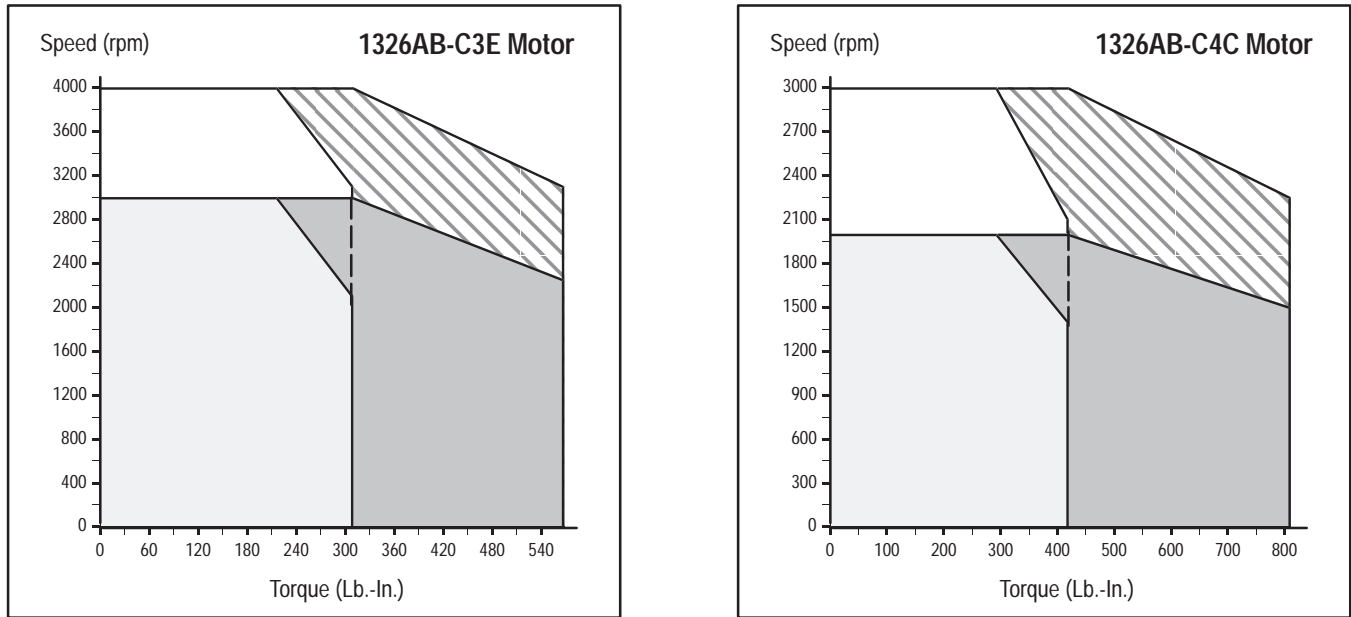

1391B Rated Operation
 1391B Intermittent Operation
 1391B-ES/1391-DES Rated Operation
 1391B-ES/1391-DES Intermittent Operation

Speed-torque curves show the rated performance of the servomotor in a 40 degree C ambient. Motor is at full rated temperature. Motor windings are at 150 degrees C with a 110 degree C rise over ambient. Motor case temperature is at approximately 100 degrees C.

Important: Curves and performance data shown are for motor and amplifier combinations where amplifier rating is equal to or greater than I_c of motor

Category	Parameter	Units	1326AB-C3E	1326AB-C4C
General	Continuous Stall Torque at 40° C Ambient	lb.-in. (N-m)	310.0 (35.0)	420.0 (47.5)
	Rated Output/1391B-ES, DES Rated Output	kW	7.5/10.0	7.0/9.3
	Peak Stall Torque/1391B-ES, DES Peak Stall Torque ³	lb.-in. (N-m)	568.0 (64.1)/568.0 (64.1)	811.0 (91.7)/811.0 (91.7)
	Continuous Stall Current ³	amperes	49.1	46.6
	Peak Stall Current/1391B-ES, DES Peak Stall Current ³	amperes	90.0/90.0	90.0/90.0
	Mechanical Time Constant ³	milliseconds	6.0	5.6
	Electrical Time Constant ³	milliseconds	13.0	13.1
	Rated Speed/1391B-ES, DES Rated Speed ³	rpm	3000/4000	2000/3000
Thermal	Maximum Ambient Temperature (without derating)	degrees C	40.0	40.0
	Insulation Class		H	H
	Thermal Time Constant	minutes	86.0	95.0
Winding	Torque Constant	at 25° C lb.-in. (N-m)/A	7.44 (0.84)	10.6 (1.20)
	Voltage Constant	RMS (L-L) at 25° C volts/1000 rpm	50.5	72.4
	Terminal Resistance	ohms (L-L) at 25° C	0.059	0.09
	Inductance	mH (L-L) at 25° C	1.0	1.54
	Mechanical	Rotor Polar Moment of Inertia	lb.-in.-s ² (kg-m ²)	0.220 (0.024)
Motor Weight		lbs. (kg)	138 (62.6)	170 (77.1)
Balance ¹		in. (mm) ²	0.0005 (0.0127)	0.0005 (0.0127)

¹ To obtain vibration velocity in inches (mm)/second use the following formula: $V_V = (D_{p-p} \times \text{rpm}) / 27.01$
 where: D_{p-p} = peak-peak displacement in in. (mm)
 V_V = Vibration velocity in in. (mm)/second
 rpm = motor speed

² peak-peak displacement

³ at 40° C

Figure 7
1326AB-C4B Motor Performance Curves

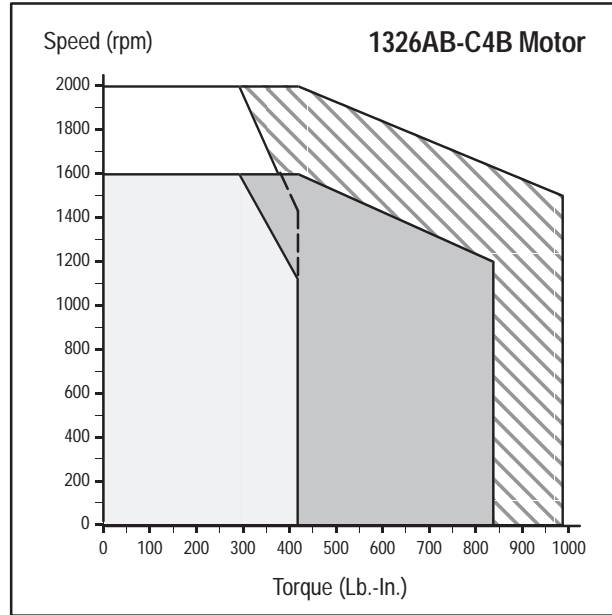

1391B Rated Operation
 1391B Intermittent Operation
 1391B-ES/1391-DES Rated Operation
 1391B-ES/1391-DES Intermittent Operation

Speed-torque curves show the rated performance of the servomotor in a 40 degree C ambient. Motor is at full rated temperature. Motor windings are at 150 degrees C with a 110 degree C rise over ambient. Motor case temperature is at approximately 100 degrees C.

Important: Curves and performance data shown are for motor and amplifier combinations where amplifier rating is equal to or greater than I_c of motor

Category	Parameter	Units	1326AB-C4B
General	Continuous Stall Torque at 40° C Ambient	lb.-in. (N-m)	420.0 (47.5)
	Rated Output/1391B-ES, DES Rated Output	kW	5.6/7.5
	Peak Stall Torque/1391B-ES, DES Peak Stall Torque ³	lb.-in. (N-m)	840.0 (94.8)/989.0 (111.8)
	Continuous Stall Current ³	amperes	38.2
	Peak Stall Current/1391B-ES, DES Peak Stall Current ³	amperes	76.4/90
	Mechanical Time Constant ³	milliseconds	5.4
	Electrical Time Constant ³	milliseconds	13.25
	Rated Speed/1391B-ES, DES Rated Speed ³	rpm	1600/2000
Thermal	Maximum Ambient Temperature (without derating)	degrees C	40.0
	Insulation Class		H
	Thermal Time Constant	minutes	95.0
Winding	Torque Constant	at 25° C lb.-in. (N-m)/A	13.0 (1.47)
	Voltage Constant	RMS (L-L) at 25° C volts/1000 rpm	89.5
	Terminal Resistance	ohms (L-L) at 25° C	0.133
	Inductance	mH (L-L) at 25° C	2.212
Mechanical	Rotor Polar Moment of Inertia	lb.-in.-s ² (kg-m ²)	0.29 (0.032)
	Motor Weight	lbs. (kg)	170 (77.1)
	Balance ¹	in. (mm) ²	0.0005 (0.0127)

¹ To obtain vibration velocity in inches (mm)/second use the following formula: $V_V = (D_{p-p} \times \text{rpm}) / 27.01$

where:
 D_{p-p} = peak-peak displacement in in. (mm)
 V_V = Vibration velocity in in. (mm)/second
 rpm = motor speed

² peak-peak displacement

³ at 40° C

Figure 8
Motor Output Shaft Radial Load vs. Thrust Load

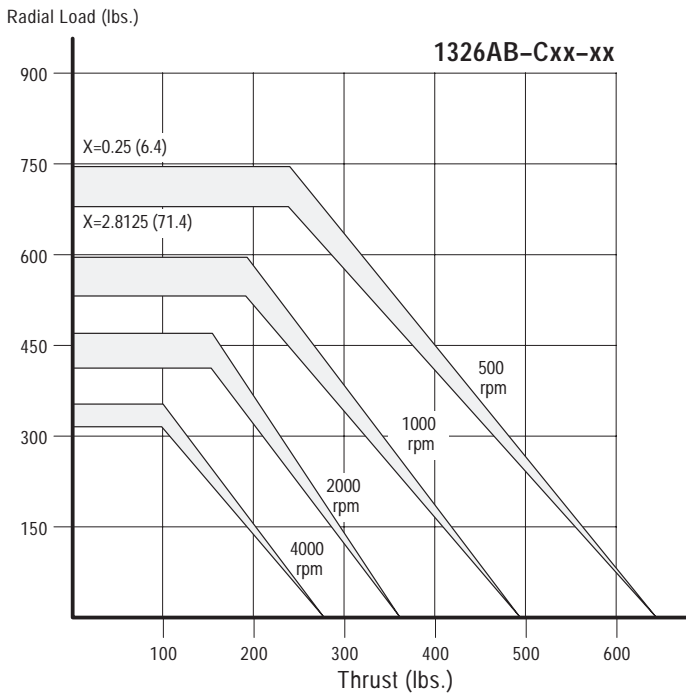
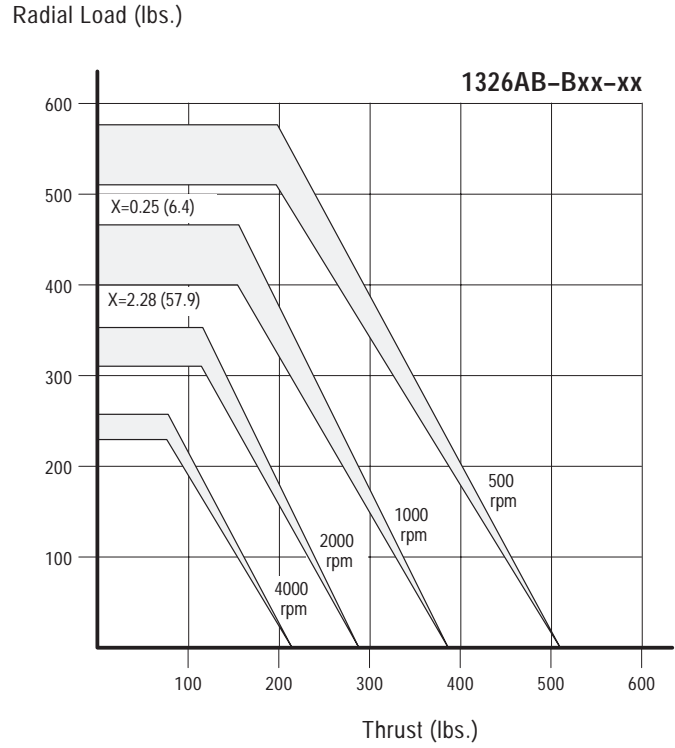
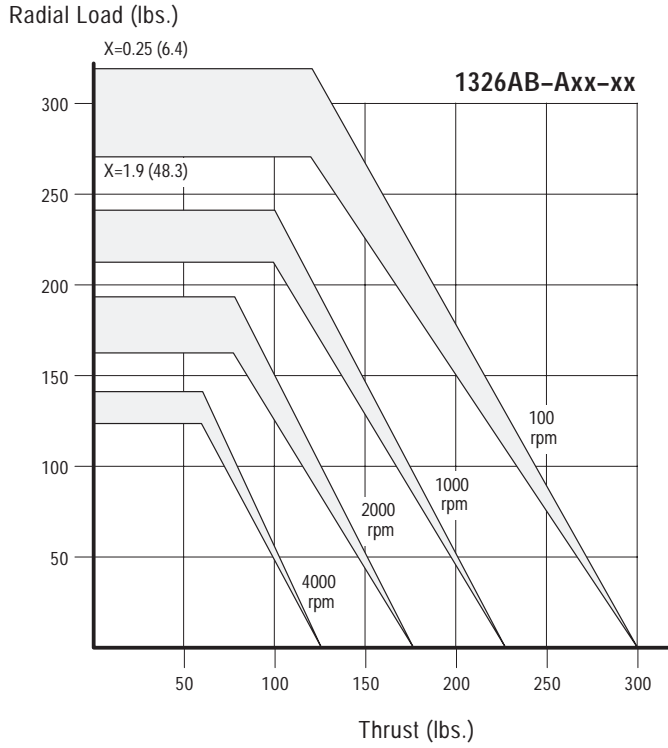

1326AB AC Servomotor 15,000 Hour B10 Bearing Life
Vertical or Horizontal Mounting

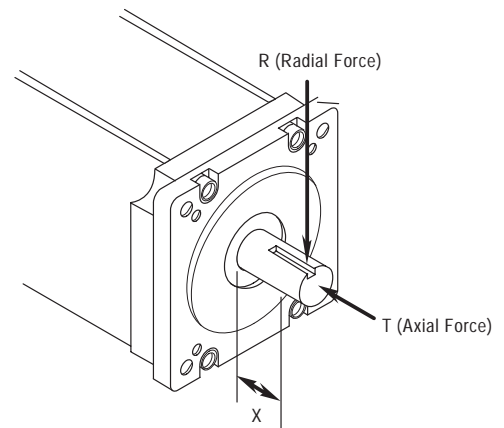

Special Order Motor Information

Motors having operating characteristics different from standard motors are available as a special order item. Refer to the data listed below. For ordering and delivery information, contact your local Allen-Bradley Sales Office.

Table A
Non-Stocked Motor Specifications

Motor Number	Tc ¹ lb.-in. (N-m)	Ic ¹ A	Tp ^{1,2} lb.-in. (N-m)	Ip ¹ A	Rated Speed rpm	Mech. Time Constant	Elec. Time Constant	Rated Output kW	Thermal Time Constant	Inertia lb.-in.-s ² (kg-m ²)	Kt lb.-in./A (N-m/A)	Ke ³ V/rpm L-L	Rt mH L-L	L mH L-L
326AB-A1E	16 (1.8)	2.6	32 (3.6)	5.2	3000	10.40ms	3.4ms	0.3	23 min	0.004 (0.0005)	7.24 (0.82)	49.5	5.710	25.20
326AB-A2G	32 (3.6)	9.0	64 (7.2)	18.0	5000	9.10ms	3.4ms	1.3	33 min	0.007 (0.0008)	4.18 (0.47)	28.5	0.950	4.19
326AB-A3G	48 (5.4)	13.5	96 (10.8)	27.0	5000	8.60ms	3.4ms	2.0	38 min	0.010 (0.001)	4.18 (0.47)	28.5	0.634	2.80
326AB-B1C	51 (5.8)	5.7	102 (11.5)	11.4	2000	9.80ms	7.3ms	0.8	40 min	0.030 (0.003)	10.50 (1.19)	71.7	1.450	14.60
326AB-B1E	51 (5.8)	8.2	102 (11.5)	16.4	3000	9.86ms	7.4ms	1.3	40 min	0.030 (0.003)	7.30 (0.82)	49.9	0.700	7.10
326AB-B2C	102 (11.5)	11.4	204 (23.1)	22.8	2000	7.90ms	7.6ms	1.7	56 min	0.050 (0.006)	10.50 (1.19)	71.7	0.726	7.30
326AB-B3C	153 (17.3)	17.0	306 (34.6)	34.0	2000	8.34ms	7.7ms	2.5	66 min	0.080 (0.009)	10.60 (1.20)	72.4	0.490	4.93
326AB-C1C	105 (11.9)	11.7	210 (23.7)	23.4	2000	6.40ms	12.6ms	1.7	47 min	0.080 (0.009)	10.60 (1.20)	50.5	0.360	6.20
326AB-C1E	105 (11.9)	16.6	210 (23.7)	33.2	3000	6.30ms	12.6ms	2.6	47 min	0.080 (0.009)	7.44 (0.84)	72.4	0.176	3.00
326AB-C2C	210 (23.7)	23.3	420 (47.5)	46.6	2000	5.40ms	13.1ms	3.5	71 min	0.140 (0.016)	10.60 (1.20)	72.4	0.180	3.08
326AB-C3C	310 (35.0)	34.4	620 (70.1)	68.8	2000	5.60ms	13.4ms	5.0	86 min	0.220 (0.024)	10.60 (1.20)	72.4	0.120	2.10

¹ at 40° C

² for 200% current settings

³ at 25° C

Motor Weights

(standard without options)

Motor Number	Weight lbs. (kg)
326AB-A1E	22 (10.0)
326AB-A2G	28 (12.7)
326AB-A3G	37 (16.8)
326AB-B1C	44 (20.0)
326AB-B1E	44 (20.0)
326AB-B2C	61 (27.7)
326AB-B3C	76 (34.5)
326AB-C1C	75 (34.0)
326AB-C1E	75 (34.0)
326AB-C2C	102 (46.3)
326AB-C3C	138 (62.6)

Servomotor Dimensions

The following figures provide approximate dimensions for the 1326AB face and flange mount motors, respectively.

Figure 9
Motor Dimensions – 1326AB-Axx Series Servomotor

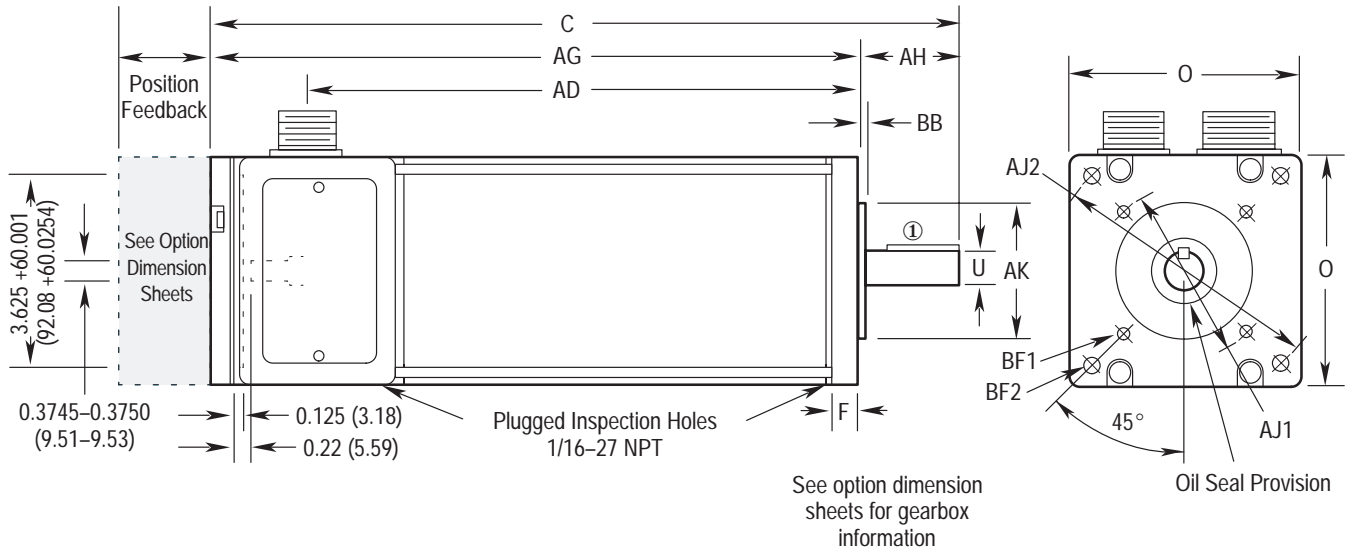

Standard Inch Combination Face/Flange Mount (in inches)

Catalog Number	Description	AD	AG	AH	AK ¹	C	O	U ²	Key
1326AB-A1x-11	without brake	8.69	10.44	2.00	2.500	12.44	4.38	0.6250	0.19 x 0.19 x 1.38
1326AB-A2x-11		10.94	12.69	2.00	2.500	14.69	4.38	0.6250	0.19 x 0.19 x 1.38
1326AB-A3x-11		13.19	14.94	2.00	2.500	16.94	4.38	0.6250	0.19 x 0.19 x 1.38
1326AB-Axx-11-K4	with optional 24V DC, 72 lb.-in. brake	add 2.25 inches to AD, AG and C							
1326AB-Axx-11-A4	with standard 90V DC, 72 lb.-in. brake	add 2.25 inches to AD, AG and C							
BF1 = 0.312 - 18 tapped hole, 0.38 deep						① Shaft Runout		0.002 T.I.R.	
BF2 = 0.344 dia.						Shaft Endplay		0.005 T.I.R.	
AJ1 = 3.250						Pilot Eccentricity		0.004 T.I.R.	
AJ2 = 5.0						Maximum Face Runout		0.004 T.I.R.	
BB = 0.125									
F = 0.56									
¹ +0.000, -0.003		² +0.000, -0.0005		BF1 & AJ1 are found on English units only.					

Metric Flange Mount (in millimeters)

Catalog Number	Description	AD	AG	AH ³	AK ⁴	C	O	U ⁵	Key
1326AB-A1x-21	without brake	278	297	40	95	337	111	19	6 x 6 x 30
1326AB-A2x-21		335	354	40	95	394	111	19	6 x 6 x 30
1326AB-A3x-21		392	411	40	95	451	111	19	6 x 6 x 30
1326AB-Axx-21-K4	with optional 24V DC, 8.1 N-m brake	add 57 millimeters to AD, AG and C							
1326AB-Axx-21-A4	with standard 90V DC, 8.1 N-m brake	add 57 millimeters to AD, AG and C							
BF2 = 10 +0.360/-0.000 dia.						① Shaft Runout		0.051 T.I.R.	
AJ2 = 115						Shaft Endplay		0.127 T.I.R.	
BB = 3.0						Pilot Eccentricity		0.102 T.I.R.	
F = 15.0						Maximum Face Runout		0.102 T.I.R.	
³ +0.5, -0.5		⁴ +0.013, -0.009		⁵ +0.009, -0.004					

Figure 10
Motor Dimensions – 1326AB-Bxx Series Servomotor

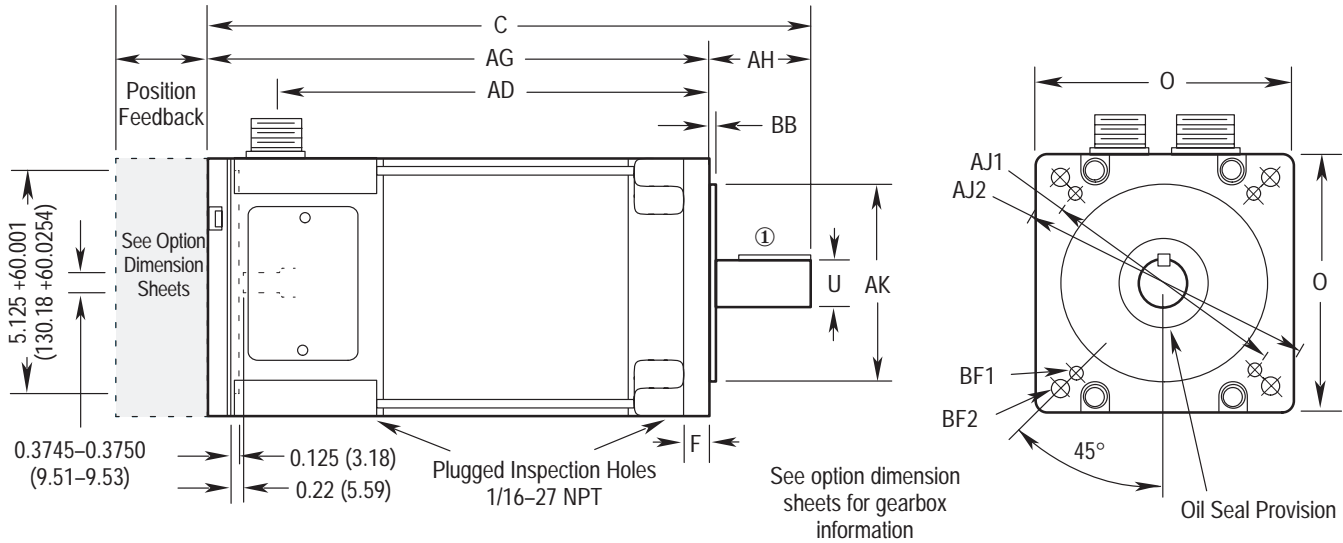

Standard Inch Combination Face/Flange Mount (in inches)

Catalog Number	Description	AD	AG	AH	AK ¹	C	O	U ²	Key
1326AB-B1x-11	without brake	10.16	11.78	2.38	4.50	14.16	5.88	1.1250	0.25 x 0.25 x 1.50
1326AB-B2x-11		13.16	14.78	2.38	4.50	17.16	5.88	1.1250	0.25 x 0.25 x 1.50
1326AB-B3x-11		16.41	18.03	2.38	4.50	20.41	5.88	1.1250	0.25 x 0.25 x 1.50
1326AB-B4x-11		19.66	21.28	2.38	4.50	23.66	5.88	1.1250	0.25 x 0.25 x 1.50
1326AB-Bxx-11-K5	with optional 24V DC, 120 lb.-in. brake	add 2.25 inches to AD, AG and C							
1326AB-Bxx-11-A5	with standard 90V DC, 120 lb.-in. brake	add 2.25 inches to AD, AG and C							
BF1 = 0.375 - 16 tapped hole, 0.38 deep						①	Shaft Runout		0.002 T.I.R.
BF2 = 0.406 dia.							Shaft Endplay		0.005 T.I.R.
AJ1 = 5.875							Pilot Eccentricity		0.004 T.I.R.
AJ2 = 7.0							Maximum Face Runout		0.004 T.I.R.
BB = 0.093									
F = 0.66									
¹ +0.000, -0.003		² +0.000, -0.0005		BF1 & AJ1 are found on English units only.					

Metric Flange Mount (in millimeters)

Catalog Number	Description	AD	AG	AH ³	AK ⁴	C	O	U ⁵	Key
1326AB-B1x-21	without brake	257	298	50	130	348	149	24	8 x 7 x 40
1326AB-B2x-21		333	374	50	130	424	149	24	8 x 7 x 40
1326AB-B3x-21		416	457	50	130	507	149	24	8 x 7 x 40
1326AB-B4x-21		498	540	50	130	589	149	24	8 x 7 x 40
1326AB-Axx-21-K5	with optional 24V DC, 13.6 N-m brake	add 57 millimeters to AD, AG and C							
1326AB-Axx-21-A5	with standard 90V DC, 13.6 N-m brake	add 57 millimeters to AD, AG and C							
BF2 = 12 +0.430/-0.000 dia.						①	Shaft Runout		0.051 T.I.R.
AJ2 = 165							Shaft Endplay		0.127 T.I.R.
BB = 4.0							Pilot Eccentricity		0.102 T.I.R.
F = 16.0							Maximum Face Runout		0.102 T.I.R.
³ +0.5, -0.5		⁴ +0.014, -0.011		⁵ +0.009, -0.004					

Figure 11
Motor Dimensions – 1326AB-Cxx Series Servomotor

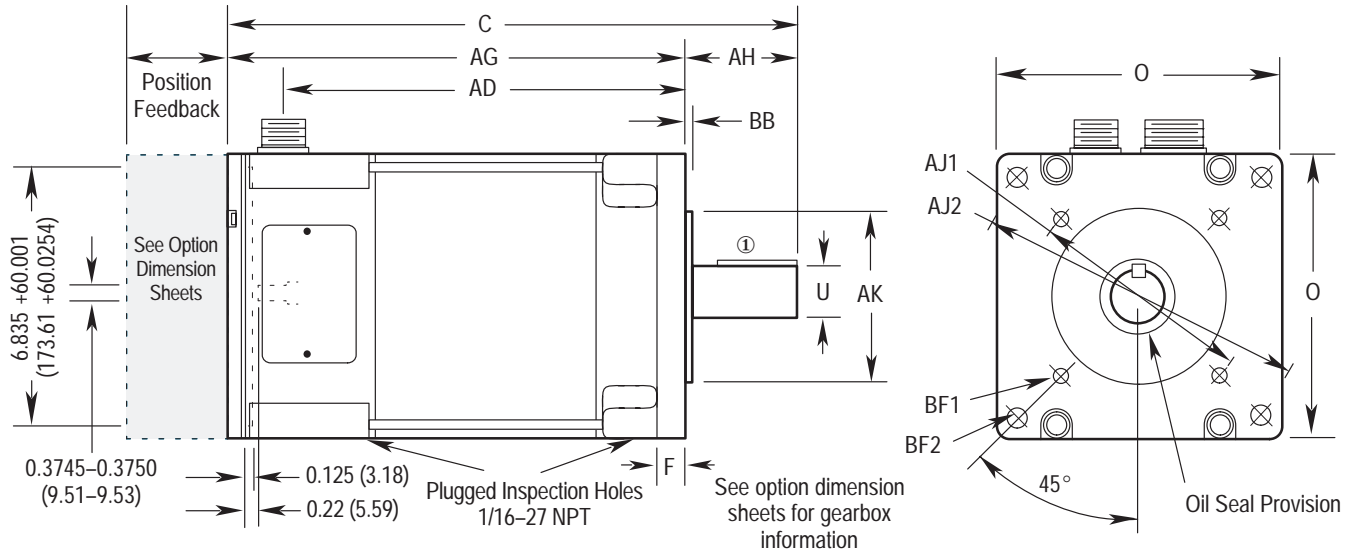

Standard Inch Combination Face/Flange Mount (in inches)

Catalog Number	Description	AD	AG	AH	AK ¹	C	O	U ²	Key
1326AB-C1x-11	without brake	10.88	12.44	3.00	4.50	15.44	7.63	1.3750	0.31 x 0.31 x 2.00
1326AB-C2x-11		13.88	15.44	3.00	4.50	18.44	7.63	1.3750	0.31 x 0.31 x 2.00
1326AB-C3x-11		17.38	18.94	3.00	4.50	21.94	7.63	1.3750	0.31 x 0.31 x 2.00
1326AB-C4x-11		20.88	22.44	3.00	4.50	25.44	7.63	1.3750	0.31 x 0.31 x 2.00
1326AB-Cxx-11-K7	with optional 24V DC, 360 lb.-in. brake				add 2.5 inches to AD, AG and C				
1326AB-Cxx-11-A7	with standard 90V DC, 360 lb.-in. brake				add 2.5 inches to AD, AG and C				
BF1 = 0.375 - 16 tapped hole, 0.69 deep						①	Shaft Runout		0.002 T.I.R.
BF2 = 0.406 dia.							Shaft Endplay		0.005 T.I.R.
AJ1 = 5.875							Pilot Eccentricity		0.004 T.I.R.
AJ2 = 9.0							Maximum Face Runout		0.004 T.I.R.
BB = 0.187									
F = 0.88									
¹ +0.000, -0.003		² +0.000, -0.0005		BF1 & AJ1 are found on English units only.					

Metric Flange Mount (in millimeters)

Catalog Number	Description	AD	AG	AH ³	AK ⁴	C	O	U ⁵	Key
1326AB-C1x-21	without brake	277	317	60	180	377	194	32	10 x 8 x 50
1326AB-C2x-21		353	393	60	180	453	194	32	10 x 8 x 50
1326AB-C3x-21		442	482	60	180	543	194	32	10 x 8 x 50
1326AB-C4x-21		531	571	60	180	631	194	32	10 x 8 x 50
1326AB-Cxx-21-K7	with optional 24V DC, 40.7 N-m brake				add 64 millimeters to AD, AG and C				
1326AB-Cxx-21-A7	with standard 90V DC, 40.7 N-m brake				add 64 millimeters to AD, AG and C				
BF2 = 15 +0.430/-0.000 dia.						①	Shaft Runout		0.051 T.I.R.
AJ2 = 215							Shaft Endplay		0.127 T.I.R.
BB = 4.0							Pilot Eccentricity		0.102 T.I.R.
F = 23.0							Maximum Face Runout		0.102 T.I.R.
³ +0.5, -0.5		⁴ +0.014, -0.011		⁵ +0.018, +0.002					

Figure 12
Motor Power & Feedback Cable Dimensions

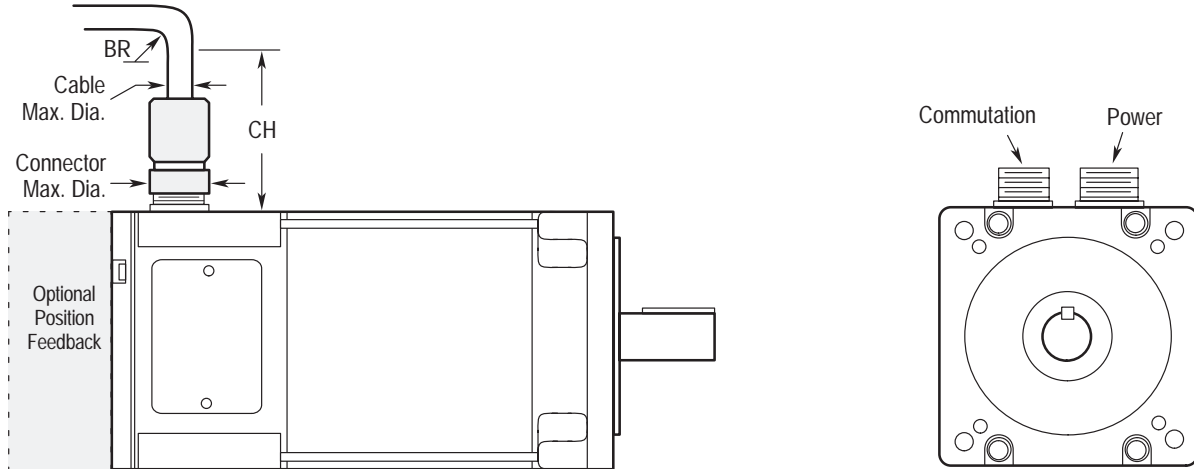

Dimensions are in inches and (millimeters)

Cable	Description	CH ¹	BR ²	Connector Max. Dia.	Cable Max. Dia.
1326-CFUxxx	Commutation Feedback	4.0 (101.6)	2.0 (50.8)	1.25 (31.75)	0.43 (10.92)
1326ES-CFUxxx ⁴	Commutation Feedback (Extended Length)	4.0 (101.6)	2.0 (50.8)	1.25 (31.75)	0.43 (10.92)
1326-CFUTxxx	Commutation Feedback (High Flex)	4.0 (101.6)	6.8 (172.7)	1.25 (31.75)	0.68 (17.27)
1326ES-CFUTxxx ⁴	Commutation Feedback (Extended Length, High Flex)	4.0 (101.6)	6.8 (172.7)	1.25 (31.75)	0.68 (17.27)
1326-CPABxxx	Motor Power – Series A4, A5	5.0 (127.0)	3.0 (76.2)	1.25 (31.75)	0.55 (13.84)
1326ES-CPABxxx ⁴	Motor Power – Series A4, A5 (Extended Length)	5.0 (127.0)	3.0 (76.2)	1.25 (31.75)	0.55 (13.84)
1326-CPABTxxx	Motor Power – Series A4, A5 (High Flex)	5.0 (127.0)	11.0 (279.4)	1.25 (31.75)	0.73 (18.54)
1326ES-CPABTxxx ⁴	Motor Power – Series A4, A5 (Extended Length, High Flex)	5.0 (127.0)	11.0 (279.4)	1.25 (31.75)	0.73 (18.54)
1326-CPCxxx	Motor Power – Series A7	5.0 (127.0)	3.0 (76.2)	1.25 (31.75)	0.73 (18.54)
1326ES-CPCxxx	Motor Power – Series A7 (Extended Length)	5.0 (127.0)	3.0 (76.2)	1.25 (31.75)	0.73 (18.54)
1326-CPCTxxx	Motor Power – Series A7 (High Flex)	5.0 (127.0)	13.1 (332.7)	1.50 (38.10)	0.87 (22.02)
1326ES-CPCTxxx	Motor Power – Series A7 (Extended Length, High Flex)	5.0 (127.0)	13.1 (332.7)	1.50 (38.10)	0.87 (22.02)
1326-CEUxxx	Encoder Feedback	4.0 (101.6)	2.0 (50.8)	1.25 (31.75)	0.51 (12.95)
1326-CVUxxx	Master/Vernier	4.0 (101.6)	2.0 (50.8)	1.25 (31.75)	0.53 (13.46)

¹ CH is described as the clearance to bend.

² BR (Bend Radius) is specified for standard 1326 cable assemblies. BR may vary on user fabricated cables. For standard cable, BR is a one time flex application. Flex cables have a much higher BR to withstand flex applications.

³ All cables should be hung or laid flat for 24 hours prior to installation. This will allow the conductors to “relax” into their natural state and guard against internal twisting.

⁴ 1326 commutation and power cables, standard and flex, are available in extended lengths of 150, 200, 250 and 300 feet (45.7, 61.0, 76.2, 91.4 meters) when using a 1391B-ES or 1391-DES drive.

Servomotor Options

This section provides detailed information on the various options available for the 1326 AC Servomotor.

Integral Holding Brake (Option -Ax or -Kx)

The 1326AB servomotor contains an integral holding brake when the catalog number contains a suffix of “-Ax” (90V DC input) or “-Kx” (24V DC input). The brake is a disc type that is spring-set upon removal of power. The brake is designed to hold a load at rest and provide limited braking torque for emergency stopping. The brake is not intended as a positioning brake (brake backlash is 0.8 arc-minutes maximum) or to be continuously cycled to assist in stopping a load. When used as a parking brake, the brake must not be energized/de-energized more than 90 times an hour. A parking brake is only meant to hold a stationary load and is not intended to stop motor movement, unless a power interruption occurs.

For further information, refer to Table B and the *Bulletin 1391 Instruction Manual*.

Table B
Holding Brake Data

Motor Catalog Number	Holding Torque <i>lb.-in. (N-m)</i>	Current Draw when Energized		Brake Response Time <i>Pickup/Dropout</i>	Weight Adder to Motor Weight <i>lbs. (kg)</i>	Inertia Adder to Mo- tor Inertia <i>lb.-in.-s² (kg-cm-s²)</i>	Cold Resistance	
		<i>-Ax (90V)</i>	<i>-Kx (24V)</i>				<i>-Ax (90V)</i>	<i>-Kx (24V)</i>
1326AB-A-11, 21	72 (8.1)	0.26A	0.88A	120ms/20ms	3.0 (1.36)	0.001 (0.001)	382 ohms	28 ohms
1326AB-B-11, 21	120 (13.6)	0.37A	1.20A	150ms/25ms	9.0 (4.08)	0.0027 (0.0031)	270 ohms	21 ohms
1326AB-C-11, 21	400 (45.1)	0.32A	1.20A	120ms/30ms	13.0 (5.90)	0.0046 (0.0053)	306 ohms	21 ohms

Brake Power Supply for 90V DC Brakes (1326-MOD-BPS)

The Brake Power Supply converts 120V AC to the voltage needed for 90V DC brakes.

Up to four brakes can be connected to one power supply. However, if independent control of multiple motors is desired, one power supply per motor must be used.

Refer to Figure 13 for dimension and wiring information.

Important: 24V DC brakes require a user supplied power supply capable of producing 24V DC at 0.88A to 1.2A.

Specifications

Power Supply Input Rating: 120V AC, single-phase, +10%, -15%

Dissipation: 5 watts per motor

Figure 13
Brake Power Supply Dimensions and Wiring

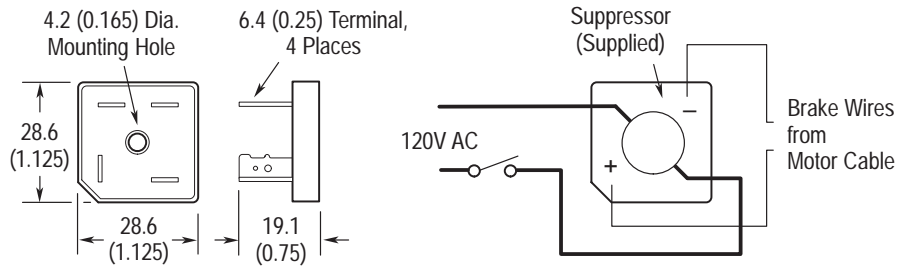

Encoder Mounting Adapters (1326AB-MOD-Mxx)

Several adapters are available for mounting Allen-Bradley 845 H or T encoders to 1326AB Servomotors. Refer to the figure below for further information.

Important: The IP 65 rating of the motor is not maintained when using this option.

Figure 14
Encoder Mounting Adapter

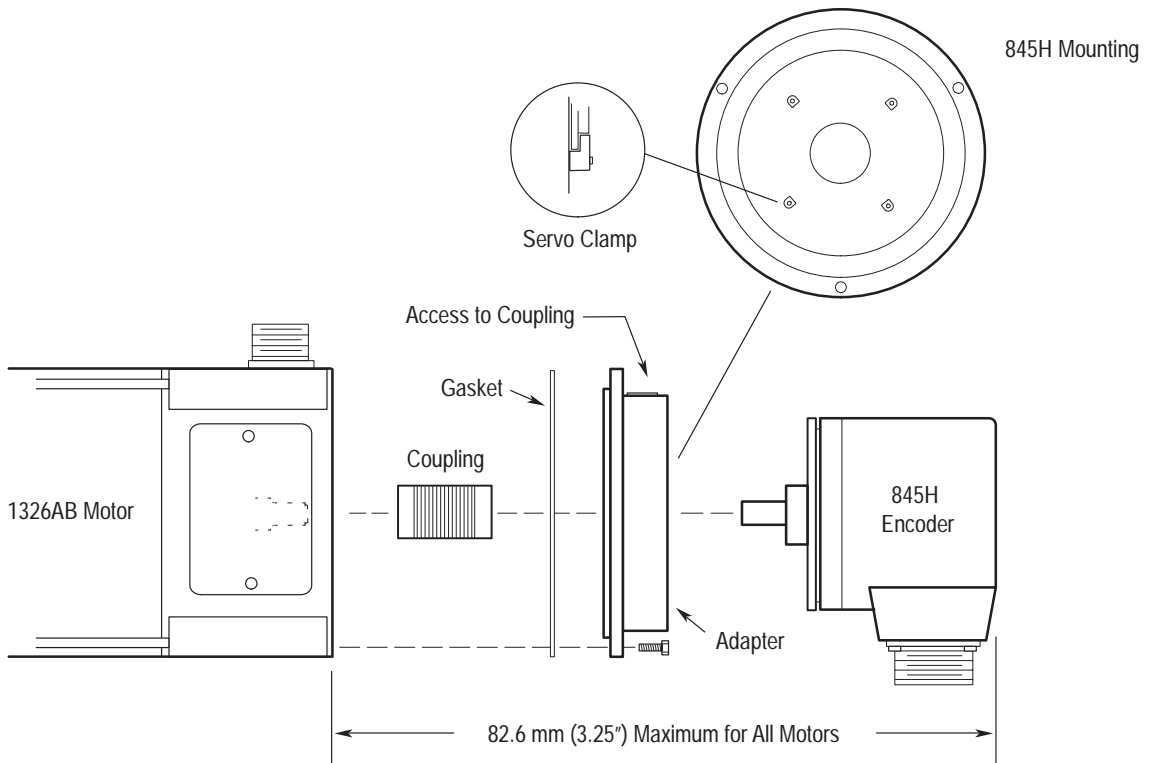

Shaft Oil Seal (1326AB-MOD-SSV-xx)

A Viton shaft oil seal is available for field installation on the motor shaft. The seal is to be used in applications where the motor shaft may be subjected to occasional oil splashes (motor is mounted to gearbox, etc.). The kit is not intended to be used in applications where the motor shaft is partially or fully submerged in oil.

Resolver Feedback Package (1326AB-MOD-Vxxxx)

Figure 15 shows the dimensions of the 1326AB Resolver Feedback Package.

Important: The IP 65 rating of the motor is not maintained when using this option.

Figure 15
Resolver Feedback Package Dimensions

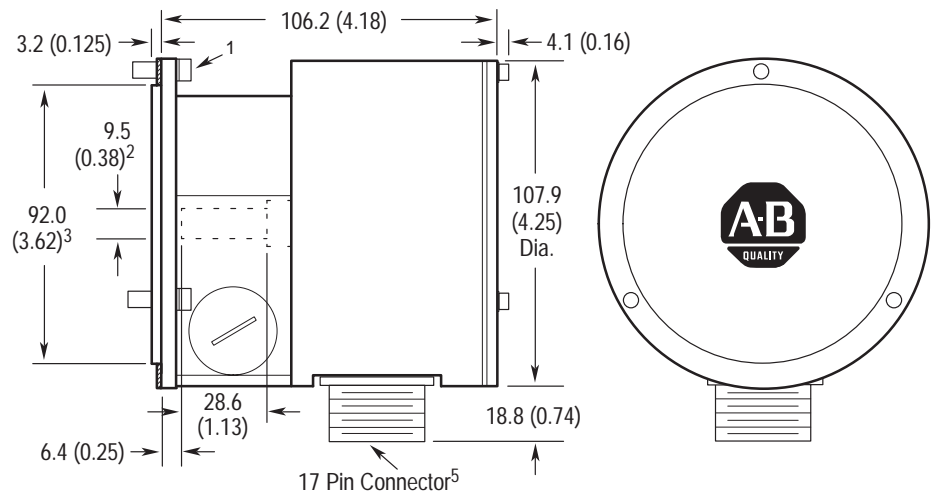

¹ 5.2 (0.206) dia. hole, 3 places equally spaced on a 101.6 (4.00) dia. Bolt Circle.

² +0.000/-0.0127 (+0.0000/-0.0005) tolerance.

³ +0.000/-0.0762 (+0.0000/-0.003) tolerance.

⁴ All mounting hardware provided in Resolver Feedback Mounting Kit.

⁵ Cannon female connector CA3102R20-29P or equivalent mounted on the package.
Cannon male mating connector CA3106F-20-295-A95 or equivalent.

⁶ Refer to the 1326AB Resolver Feedback Package Product Data for additional information.

Resolver Feedback Mounting Adapter Kit (1326AB-MOD-Mx)

The Resolver Feedback Mounting Kit provides a means of mounting the 1326AB Resolver to B and C series motors. An adapter is not needed for A series motors. Refer to Figure 16 for dimension information.

Important: The IP 65 rating of the motor is not maintained when using this option.

Figure 16
1326AB Resolver Mounting Kit Dimensions

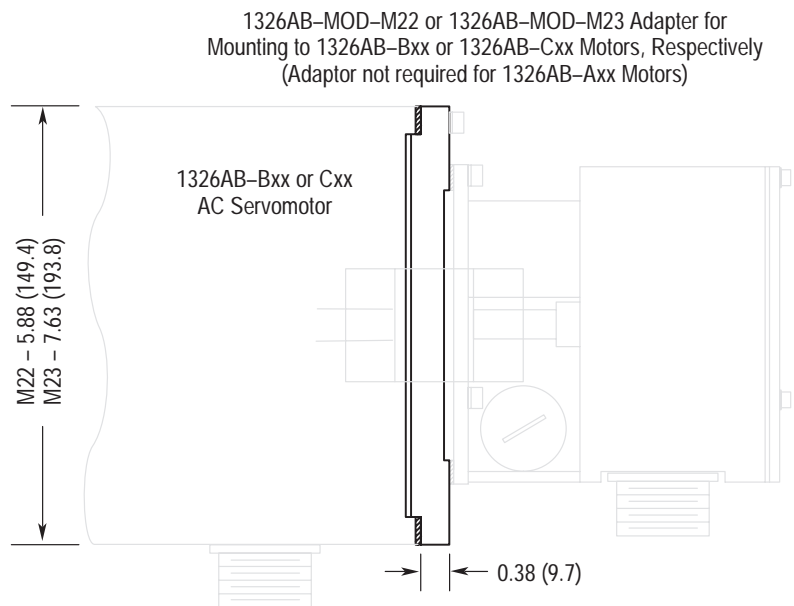

Motor Junction Box Kit (1326AB-MOD-RJxx)

The Motor Junction Box Kit provides axially mounted connectors. The connector version allows the motor connectors to be brought out axially to the motor without further wiring.

The IP65 rating of the motor is maintained when using this junction box.

Dimensions for the junction box are shown in the following figure.

Figure 17
Motor Junction Box Dimensions

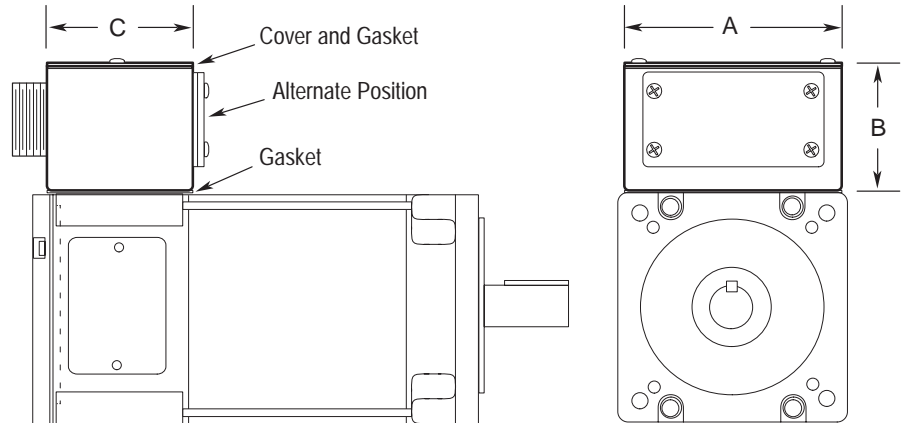

Dimension	with Connectors
A	4.13 (105.0)
B	2.44 (62.0)
C	2.50 (190.5)

Blower Kits (1326AB-MOD-G3, G4)

Two blower kits are available for use with 1326AB “C” Series AC Servomotors. The “G3” kit is designed for the “C2E” and “C4B” servomotors. The continuous current rating of all other “C” frame motors is too high to gain the benefit of the blower kit. The “G3” will not work on motors with a rear mounted encoder. The “G4” kit is designed for the “C4B” motor only. Each kit consists of an impedance protected fan (UL recognized, CSA approved), housing, grill guard and necessary hardware.

Important: The IP 65 rating of the motor is not maintained when using this option.

Specifications

Input Voltage	220/240V AC, 50/60 Hz., single-phase
Line Amperes	0.15 / 0.14
Locked Rotor Amperes	0.23 / 0.23
Fan Output	240 CFM
Air Inlet Clearance	6 inches (152.4 mm)
Weight	4 lbs. (1.81 kg)

The following table illustrates the operational improvements realized when the blower kit is installed on the motors shown. Refer to Figure 18 for dimensions.

Table C
Performance Improvements with the Blower Kit

Motor Catalog Number	Motor without Blower		Motor with Blower	
	RMS Cont. Torque ¹ <i>lb.-in. (N-m)</i>	Continuous Amperes <i>A</i>	RMS Cont. Torque ¹ <i>lb.-in. (N-m)</i>	Continuous Amperes ² <i>A</i>
1326AB-C2E ³	210 (23.7)	33.2	285 (32.2)	45.0
1326AB-C4B ⁴	420 (47.5)	38.2	505 (57.1)	45.0

¹ at 40° C ambient.

² Amplifier available current may limit actual torque improvement. Continuous output cannot exceed 45A.

³ Works with G3 option only.

⁴ Works with G3 and G4 option.

Figure 18
Blower Kit Dimensions

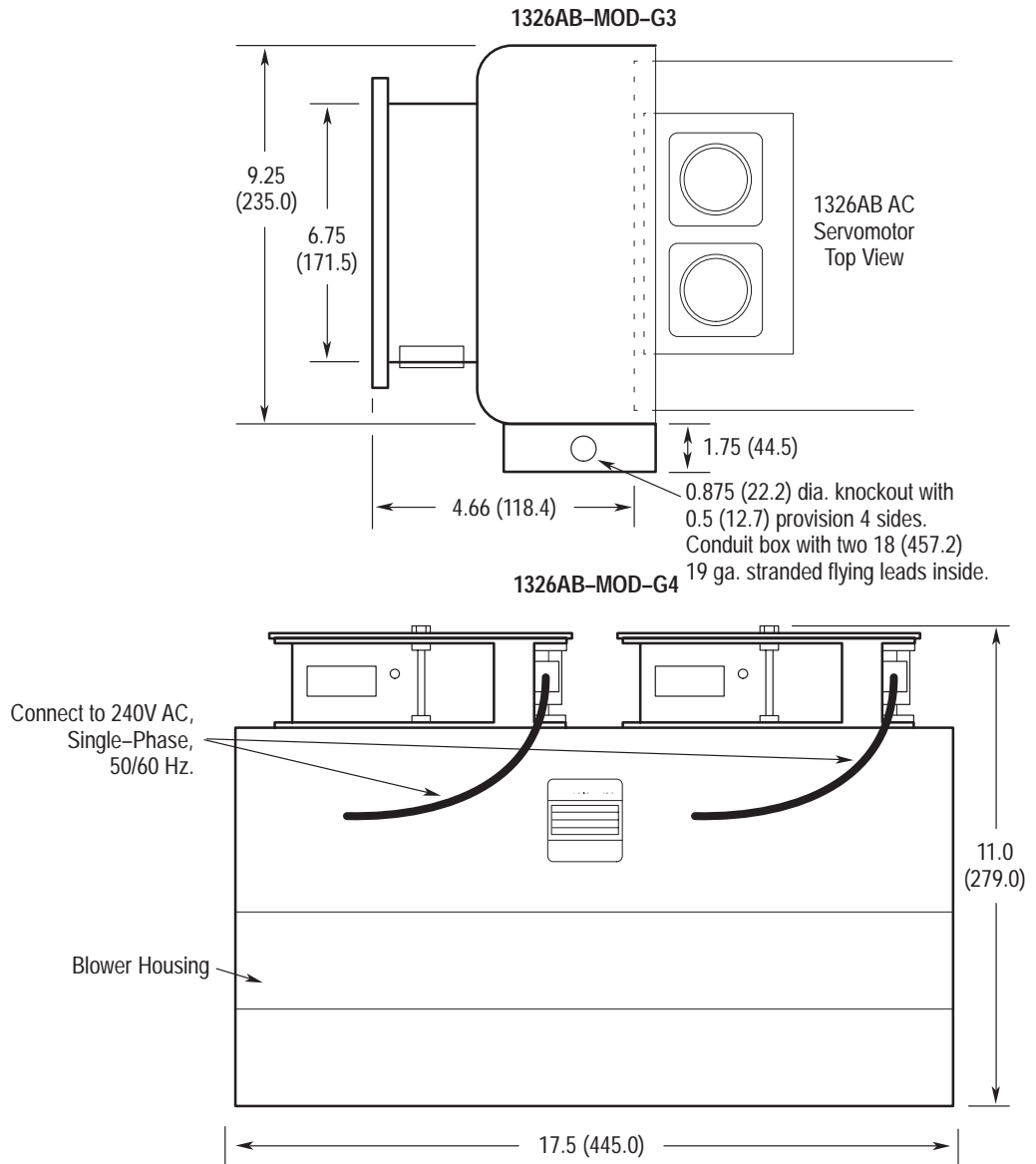

Cable Wiring Information

Pin-outs and interconnect information for the various 1326 cables are provided in this section.

1326-CFUxx, 1326ES-CFUxx ¹, 1326-CFUTxx, 1326ES-CFUTxx ¹ Commutation Cable

Wire Color	Gauge	Connector Pin	1391 Terminal #
Black	#20	A	TB1-10
White	#20	B	TB1-9
Shield - Drain	#20	N/C	TB1-8
Black	#20	D	TB1-7
Red	#20	E	TB1-6
Shield - Drain	#20	N/C	TB1-5
Black	#20	H	TB1-4
Green	#20	G	TB1-3
Shield - Drain	#20	N/C	TB1-2
Braided Shield	#36	N/C	TB1-1 to Ground Stud

1326-CPABxx, 1326ES-CPABxx ¹, 1326-CPABTxx, 1326ES-CPABTxx ¹ Motor Power Cable

Wire Number	Wire Color	Gauge	Connector Pin	1391 Terminal #
1	Black	12	F	TB5-1
2	Black	12	I	TB5-2
3	Black	12	B	TB5-3
4	Black	16	D	Brake Power (+)
5	Black	16	E	Thermal Switch
6	Black	16	C	Brake Power (-)
7	Shield/Drain	16	G	Stud Ground
8	Black	16	H	Stud Ground
9	Black	16	A	Thermal Switch

1326-CPCxx, 1326ES-CPCxx ¹, 1326-CPCTxx, 1326ES-CPCTxx ¹ Motor Power Cable

Wire Number	Wire Color	Gauge	Connector Pin	1391 Terminal #
1	Black	8	D	TB5-1
2	Black	8	E	TB5-2
3	Black	8	F	TB5-3
4	Shield/Drain	12	A	Stud Ground
5	Black	12	B	Stud Ground
6	Black	16	G	Thermal Switch
7	Black	16	H	Brake Power (+)
8	Black	16	I	Brake Power (-)
9	Black	16	C	Thermal Switch

¹ 1326ES, extended length cables need to interface with 1391 B-ES or 1391-DES drives.

1326-CVUxx Master/Vernier Resolver Cable

Master/ Vernier	Pair	Wire Color	Gauge	Connector Pin	Description
Master	1	White	22	A	Rotor 1
		Black	22	B	Rotor 2
	2	Red	22	D	Stator 1
		Black	22	F	Stator 3
	3	Orange	22	E	Stator 2
		Black	22	G	Stator 4
Vernier	4	Blue	22	J	Rotor 1
		Black	22	K	Rotor 2
	5	Green	22	N	Stator 2
		Black	22	R	Stator 4
	6	Violet	22	M	Stator 1
		Black	22	P	Stator 3

Pairs 1, 2 and 3 are used with single device format resolvers (i.e. 1:1, 1:2, 1:2.5 and 1:5).

1326-CEUxx Encoder Feedback Cable

Pair	Wire Color	Gauge	Connector Pin
1	Black	22	H
	White	22	A
2	Black	22	F
	Red	22	D
3	Black	22	J
	Orange	22	C
4	Black	22	I
	Blue	22	B
5	Black	22	F
	Green	22	E

Servomotor Application Guide

The following steps are a general guide designed to assist in servomotor selection. Formulas provided on the following pages should be used in conjunction with the steps below to determine correct motor sizing. For further assistance, complete the appropriate Application Data Sheet (pages 38-43) and contact your local Allen-Bradley Sales Office.

1. Determine the motor speed requirements.

Based on the power train configuration of your application (leadscrew, rack and pinion, conveyor) determine the average and peak rpm of the servomotor. Choose the velocity profile that provides the closest approximation of your cycle.

a) Triangular Velocity Profile.

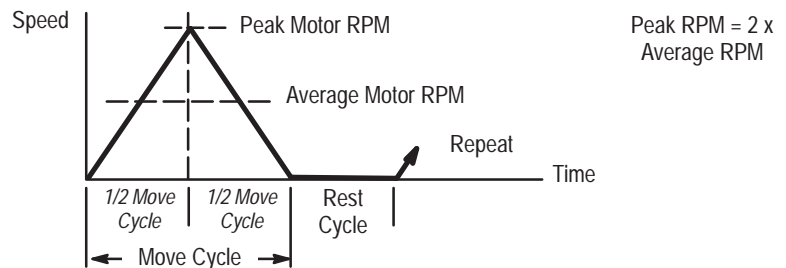

b) Trapezoidal Velocity Profile.

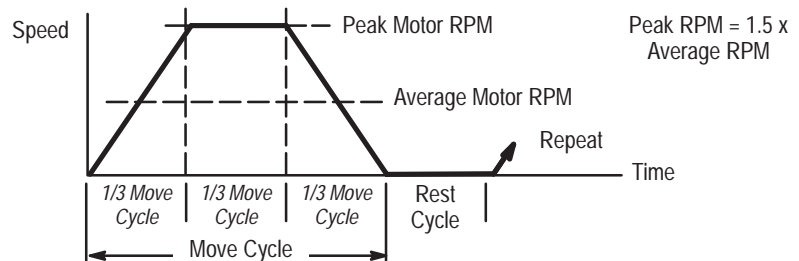

2. Determine the minimum continuous motor torque required.

Calculate motor torque (T_m) using the formulas on page 32, 34 or 36.

3. Determine the peak motor torque required to accelerate the load.

If the motor must accelerate within a specified time, determine the system inertia using the formula sheets for your specific power train configuration, otherwise go to step 5. Use the time (Time) to achieve peak rpm, change in rpm (Δrpm), power train inertia (System Inertia) and load torque (T_l) in one of the two formulas that follow:

System Inertia in lb.-ft.²

$$\text{Peak Torque} = \frac{\text{System Inertia} \times \Delta\text{rpm}}{308 \times \text{Time (to accelerate)}} + T_l$$

where:

Peak Torque = total motor torque required to accelerate the load in lb.-ft.

System Inertia = total system inertia (including motor) in lb.-ft.²

Time = acceleration time (in seconds)

T_l = load torque present at the motor shaft during accel in lb.-ft.

Δrpm = change in motor velocity during acceleration time.

System Inertia in lb.-in.-s²

$$\text{Peak Torque} = \frac{\text{System Inertia} \times \Delta\text{rpm}}{9.6 \times \text{Time (to accelerate)}} + \text{TI}$$

where:

- Peak Torque = total motor torque required to accelerate the load in lb.-in.
- System Inertia = total system inertia in lb.-in.-s² (listed as Jtjm on formula sheets)
- Time = acceleration time (in seconds)
- TI = load torque present at the motor shaft during accel in lb.-in.
- Δrpm = change in motor velocity during acceleration time.

4. If the motors total time to accelerate/decelerate (t₁ + t₃) exceeds 20% of the total cycle time (t₁+t₂+t₃+t₄), determine the motors average torque with the formula shown.

Duty Cycle Profile

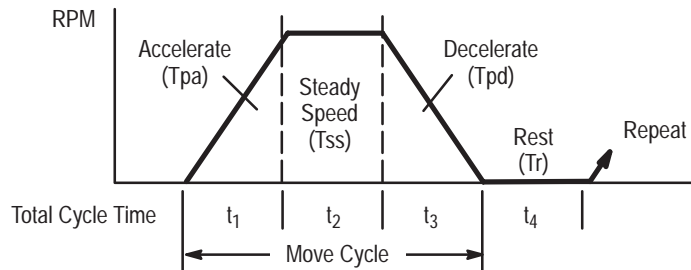

$$\text{Trms} = \sqrt{\frac{\text{Tpa}^2 \times t_1 + \text{Tss}^2 \times t_2 + \text{Tpd}^2 \times t_3 + \text{Tr}^2 \times t_4}{t_1 + t_2 + t_3 + t_4}}$$

where:

- Trms The motors RMS or average torque over the duty cycle. (Expressed in lb.-in. or lb.-ft. The same units must be used throughout the formula.)
- Tpa Motor peak torque to accelerate to maximum speed. (Expressed in lb.-in. or lb.-ft. The same units must be used throughout the formula.)
- Tss Motor torque present at the motor shaft during constant speed segment. (Expressed in lb.-in. or lb.-ft. The same units must be used throughout the formula.)
- Tpd Motor peak torque to decelerate to zero speed. (Expressed in lb.-in. or lb.-ft. The same units must be used throughout the formula.)
- Tr Torque when motor is at zero speed (typically is Tss).
- t₁, t₂, t₃, t₄ Time for each portion of the duty cycle in seconds.

5. To select a servomotor:

- a) Select a motor with maximum speed capability of at least the peak rpm calculated in step 1.
- b) Select a motor with continuous torque capability equal to or greater than the value determined in step 2 or 4, whichever is greater.
- c) Select a motor with the capability to supply peak torque as determined in step 3, up to the maximum speed determined in step 1.

Servomotor Driven Leadscrew Formulas

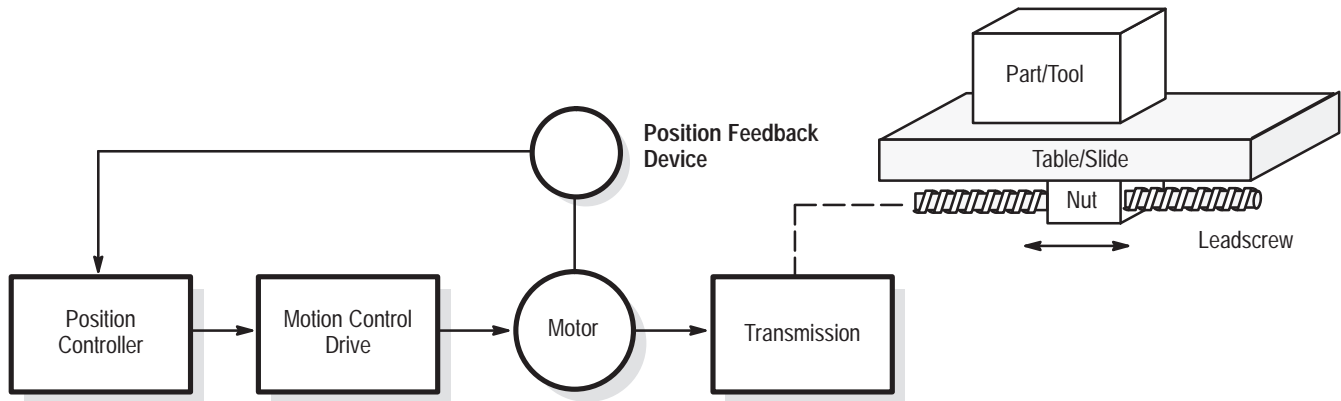

Motor Speed

$$Nm = \frac{V1}{Lead} \times G.R.$$

Continuous Torque at the Leadscrew

$$Tb = \frac{W1 \times u \times Lead}{6.28 \times e_1} + \frac{Thrust \times Lead}{6.28 \times e_1} + \frac{Thrust \times Lead \times u}{6.28 \times e_1} + \frac{W1 \times Lead}{6.28 \times e_1} \text{ sine } \theta$$

(1) (2) (3) (5)

Continuous Motor Torque

$$Tm = \frac{Tb}{G.R. \times e_2} \times 1.1$$

(4) (6)

Total System Inertia

$$J_{tjm} = \left[\frac{W1}{386} \left(\frac{Lead}{6.28} \right)^2 + Jb \right] \times \frac{1}{G.R.^2} + Jgb + Jm$$

Accelerating Torque

See step 3 of the *Servomotor Application Guide* on page 30.

Where:

e = Efficiency of leadscrew, e_1 (90% typical) or gearbox, e_2 (95% typical).
 $G.R.$ = Ratio of motor speed to leadscrew speed.
 Jb = Leadscrew inertia (lb.-in.-s²).
 Jgb = Gearbox inertia at the motor shaft (lb.-in.-s²).
 Jm = Motor inertia (lb.-in.-s²).
 J_{tjm} = Total system inertia at the motor shaft (lb.-in.-s²).
 $Lead$ = Movement of slide in inches per revolution of leadscrew.
 Nm = Motor velocity (rpm).

Tb = Torque at leadscrew (lb.-in.).
 $Thrust$ = Cutting force applied by slide/load on a workpiece (lbs).
 Tl = Load torque present at the motor shaft during accel (lb.-in.).
 Tm = Load torque required at the motor (lb.-in.).
 u = Table/slide sliding coefficient of friction (typically 0.03 to 0.2).
 $V1$ = Linear velocity of slide/load (IPM).
 $W1$ = Weight of slide and load (lbs.).
 θ = Angle of leadscrew position referenced from the horizontal axis (0°).

Notes:

- (1) Friction torque generated by the weight of the table/slide and part/tool.
- (2) Torque required for thrust (cutting force) load.
- (3) Friction torque generated by the thrust (cutting force) load (approximation).
- (4) Safety factor to account for torque required to overcome seals, gib adjustments, etc. (10% of Tm , min.).
- (5) This term is for a non-counterbalanced, non-horizontal axis.
- (6) System inertia should not exceed 5 times the motor inertia.

Typical Leadscrew Data

(Using Formulas from Previous Page)

Torque at Lead to Produce 1000 lbs. Thrust Force

1. Divide the lb.-in. value shown by efficiency of screw to obtain corrected value.

Lead (in./rev)	Torque (lb.-in.)	Lead (in./rev)	Torque (lb.-in.)
0.200	31.84	0.333	53.02
0.250	39.80	0.500	79.61
0.300	47.77	1.000	159.23

2. For thrust other than 1000 lbs.

$$\text{Torque} = \frac{\text{Required Thrust}}{1000} \times \text{Torque at 1000 lbs.}$$

Inertia of the Leadscrew

1. To determine total leadscrew inertia.

$$\text{Leadscrew Inertia} = \frac{\text{Total Leadscrew Length (in.)}}{10} \times \text{Inertia (per 10" length)}$$

Diameter (inches)	Inertia (10" length) (lb.-in.-s ²)	Diameter (inches)	Inertia (10" length) (lb.-in.-s ²)
0.50	0.000048	2.00	0.0115
0.75	0.00023	2.25	0.0184
1.00	0.00072	2.50	0.0281
1.25	0.0018	2.75	0.0412
1.50	0.0038	3.00	0.0583
1.75	0.0068	3.50	0.1080

2. Formula to determine leadscrew inertia.

$$J_b = 0.000073^{(1)} \times D^4 \times L$$

where:

D = Screw diameter in inches.

L = Screw length in inches.

⁽¹⁾ Leadscrew is assumed to be made of steel. If it is made of aluminum, the 0.000073 constant becomes 0.000024.

Inertia of the Slide/Table Reflected to the Motor per 1000 lbs. Weight

1. For slide/table weight other than 1000 lbs.

$$\text{Slide/Table Inertia at Leadscrew} = \frac{\text{Actual Weight}}{1000} \times \text{Reflected Inertia (1000 lbs.)}$$

Lead (in./rev)	Reflected Inertia (per 1000 lbs.) (lb.-in.-s ²)	Lead (in./rev)	Reflected Inertia (per 1000 lbs.) (lb.-in.-s ²)
0.200	0.0026	0.333	0.0074
0.250	0.0042	0.500	0.0167
0.300	0.0060	1.000	0.0666

Servomotor Driven Rack and Pinion Formulas

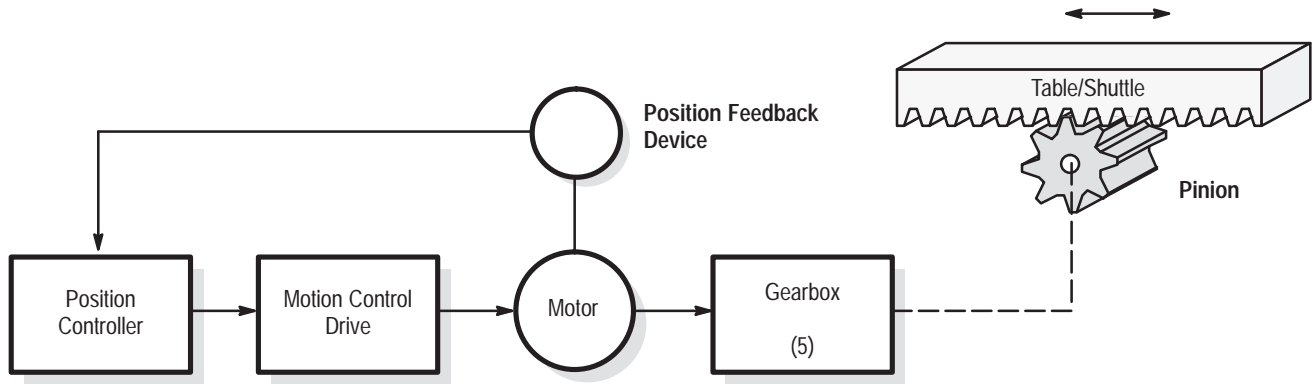

Motor Speed

$$Nm = \frac{V1}{6.28 \times R} \times G.R.$$

Continuous Torque at the Pinion

$$T_{pin} = \frac{R \times W1 \times u}{e_1} + \frac{R \times Thrust}{e_1} + \frac{R \times Thrust \times u}{e_1} + \frac{R \times W1}{e_1} \sin \theta$$

non counter balanced,
non-horizontal axis

Continuous Motor Torque

$$T_m = \frac{T_{pin}}{G.R. \times e_2} \times 1.1 \quad (6)$$

Total System Inertia

$$J_{tjm} = \left[\frac{W1}{386} \times R^2 + J_{pin} \right] \times \frac{1}{G.R.^2} + J_{gb} + J_m$$

Accelerating Torque

See step 3 of the *Servomotor Application Guide* on page 30.

Where:

e = Efficiency of pinion to rack mesh (95%) e_1 or gearbox (95%/mesh) e_2 .
 $G.R.$ = Ratio of motor speed to pinion speed.
 J_{gb} = Gearbox inertia at the motor shaft (lb.-in.-s²).
 J_m = Motor inertia (lb.-in.-s²).
 J_{pin} = Pinion inertia (lb.-in.-s²).
 J_{tjm} = Total system inertia at the motor shaft (lb.-in.-s²).
 Nm = Motor velocity (rpm).
 R = Pinion radius (in.).

Thrust = Force applied by table against workpiece, stop, etc. (lbs).
 Tl = Load torque present at the motor shaft during accel (lb.-in.).
 Tm = Continuous torque required at the motor (lb.-in.).
 T_{pin} = Continuous torque required at the pinion (lb.-in.).
 u = Sliding coefficient of friction of table or shuttle support bearings (typically 0.03 to 0.2).
 $V1$ = Linear velocity of slide/load (IPM).
 $W1$ = Weight of table/shuttle and load (lbs.).

Notes:

- (1) Friction torque required to move table/load.
- (2) Motor torque required for thrust load.
- (3) Friction torque generated by the thrust load.
- (4) Safety factor to account for torque required to overcome misalignment, mechanical adjustments, etc. (10% of T_m minimum).
- (5) Gearbox/reducer typically required between motor and pinion.
- (6) System inertia should not exceed 5 times the motor inertia.

Typical Rack & Pinion System Data (Using Rack and Pinion Formulas from Previous Page)

Torque at Pinion to Produce 1000 lbs. Thrust Force

1. Divide lb.-in. value shown at pinion by gearbox ratio and efficiency to obtain required motor torque (Tm)
2. To determine pinion torque for other thrust values, divide the thrust by 1000 and multiply by the pinion torque shown for the proper radius.

Pinion Radius ¹ (inches)	Pinion Torque (lb.-in.)	Pinion Radius ¹ (inches)	Pinion Torque (lb.-in.)
0.5	526.3	2.0	2105.3
1.0	1052.6	3.0	3157.9
1.5	1578.9	4.0	4210.5

¹ Pinion efficiency of 95% assumed.

Torque at Pinion to Move 1000 lbs. Total Table/Slide Weight

1. Divide the lb.-in. value shown at pinion by gearbox ratio and efficiency to obtain required motor torque (Tm)
2. To determine pinion torque for other weight values, divide the weight by 1000 and multiply by the pinion torque shown for the proper radius.

Pinion Radius ¹ (inches)	Pinion Torque ² (lb.-in.)				
	u=0.03	u=0.05	u=0.1	u=0.15	u=0.2
0.5	15.8	26.3	52.6	78.9	105.3
1.0	31.6	52.6	105.2	157.9	210.5
1.5	47.4	78.9	157.8	236.7	315.9
2.0	63.2	105.2	210.4	315.6	421.2
3.0	94.7	157.9	315.6	473.4	631.8
4.0	126.3	210.4	420.8	631.2	842.4

¹ Pinion efficiency of 95% assumed.

² u = Coefficient of friction.

Inertia of Table Plus Load Reflected to Pinion per 1000 lbs. Weight

1. Divide the inertia value by the square of the gearbox ratio to obtain system inertia at the motor.
2. To determine reflected inertia for other weights, divide the weight by 1000 and multiply by the inertia shown for the appropriate radius.

Pinion Radius (inches)	Reflected Load Inertia (lb.-in.-s ²)	Pinion Radius (inches)	Reflected Load Inertia (lb.-in.-s ²)
0.5	0.648	2.0	10.360
1.0	2.590	3.0	23.300
1.5	5.830	4.0	41.450

3. Formula to determine pinion inertia.

$$J_{pin} = 0.000073^{(1)} \times D^4 \times WH$$

where:

D = Pinion diameter in inches.

J_{pin} = Inertia in lb.-in.-s²

WH = Pinion width in inches.

⁽¹⁾ Pinion is assumed to be made of steel. If it is made of aluminum, the 0.000073 constant becomes 0.000024.

Servomotor Driven Conveyor Formulas

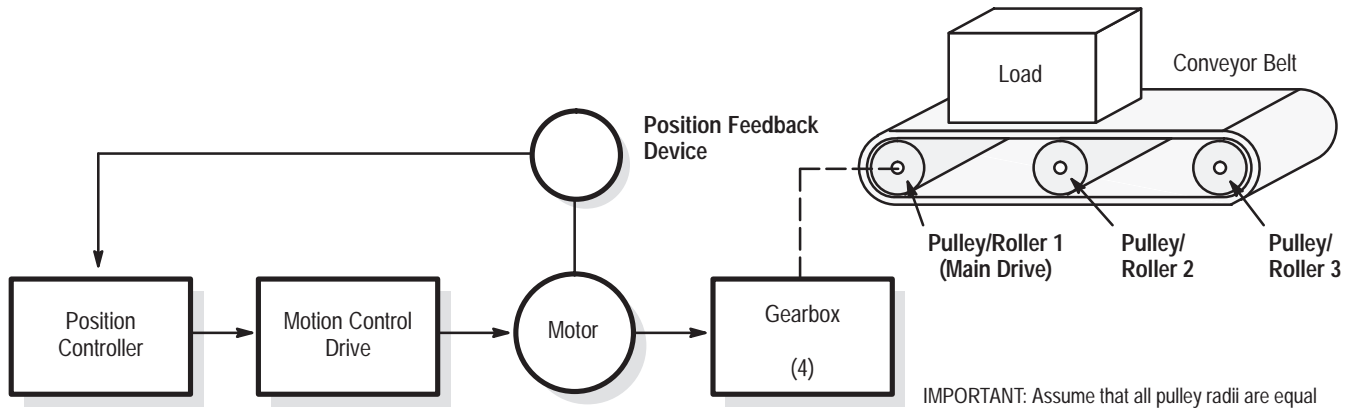

Motor Speed

$$Nm = \frac{V1}{6.28 \times R} \times G.R.$$

Continuous Torque at Pulley/Roller 1

$$Tp/r = \frac{R \times W1 \times u}{e_1} + \frac{R \times Wb \times u}{e_1}$$

(1) (2)

Continuous Motor Torque

$$Tm = \frac{Tp/r}{G.R. \times e_2} \times 1.25$$

(3) (5)

Total System Inertia

$$Jtjm = \frac{W1}{386} \times R^2 \times \frac{1}{G.R.^2} + \frac{Jpull_{1+2+3}}{G.R.^2} + Jgb + Jm$$

Accelerating Torque

See step 3 of the *Servomotor Application Guide* on page 30.

Where:

e = Efficiency of drive roller to gearbox (95% typical) e_1 and gearbox (95%/mesh typical) e_2 .
 $G.R.$ = Ratio of motor speed to pinion speed.
 Jgb = Gearbox inertia at the motor shaft (lb.-in.-s²).
 Jm = Motor inertia (lb.-in.-s²).
 $Jpull$ = Pulley + roller inertia, 1, 2, 3 (lb.-in.-s²).
 $Jtjm$ = Total system inertia at the motor shaft (lb.-in.-s²).
 Nm = Motor velocity (rpm).

R = Pulley/roller radius (in.).
 TI = Load torque present at the motor shaft during accel (lb.-in.).
 Tm = Continuous torque required at the motor (lb.-in.).
 Tp/r = Continuous torque required at the main drive pulley/roller (lb.-in.).
 u = Rolling coefficient of friction. Typically 0.03 to 0.05 for ball bearing rollers.
 $V1$ = Linear velocity of load (IPM).
 Wb = Weight of conveyor belt (lbs.).
 $W1$ = Weight of load and belt (lbs.).

Notes:

- (1) Torque required to move the load at pulley/roller 1 (lb.-in.).
- (2) Torque required to move the belt at pulley/roller 1 (lb.-in.).
- (3) Safety factor to account for torque required to overcome miscellaneous tensions, etc.
- (4) Gearbox/reducer typically required between motor and pulley/drive roller.
- (5) System inertia should not exceed 5 times the motor inertia.

Typical Conveyor System Data

(Using Conveyor Formulas from Previous Page)

Torque at Drive Pulley/Roller 1 w/1000 lbs. Load

1. Divide lb.-in. value shown at the roller by the gearbox ratio, roller/ belt (e_1) and gearbox (e_2) efficiency to obtain required motor torque (T_m)
2. To determine pulley/roller torque for other load values, divide the load weight by 1000 and multiply by the pulley/roller torque shown for the appropriate radius.

Roller Radius ¹ (inches)	Torque at Pulley 1 ² (lb.-in.)				
	$u=0.03$	$u=0.05$	$u=0.1$	$u=0.15$	$u=0.2$
0.5	15.8	26.3	52.6	78.9	105.3
1.0	31.6	52.6	105.2	157.9	210.5
1.5	47.4	78.9	157.8	236.7	315.9
2.0	63.2	105.2	210.4	315.6	421.2
3.0	94.7	157.9	315.6	473.4	631.8
4.0	126.3	210.4	420.8	631.2	842.4

¹ Pinion efficiency of 95% assumed.

² u = Coefficient of friction.

3. Formula used to determine torque at pulley/roller.

$$\text{Torque} = \frac{R \times W1 \times u}{e} \quad \text{where:} \quad W1 = 1000 \text{ lbs.}$$

Inertia of the Load Reflected to the Drive Pulley/Roller per 1000 lbs. Load (does not include roller, pulley or belt inertia)

1. Divide the inertia value shown by the square of the gearbox ratio to obtain system inertia at the motor.
2. To determine reflected inertia for other weights, divide the weight by 1000 and multiply by the inertia shown for the appropriate radius.

Roller Radius (inches)	Reflected Load Inertia (lb.-in.)
0.5	0.648
1.0	2.590
1.5	5.830
2.0	10.360
3.0	23.300
4.0	41.450

3. Formula to determine inertia of each roller or pulley.

$$J_r = 0.0012^{(1)} \times [(D_1^4 \div 16) - (D_2^4 \div 16)] \times L$$

where:

D_1 = Pulley/roller outer diameter in inches.
 D_2 = Pulley/roller inner diameter in inches.
 L = Pulley/roller width in inches.

⁽¹⁾ Pulley/roller is assumed to be made of steel. If it is made of aluminum, the 0.0012 constant becomes 0.00004.

Leadscrew Application Data for Point to Point Positioning

A. CUSTOMER _____

B. AXIS DESCRIPTION _____

C. NEW SYSTEM

D. EXISTING EQUIPMENT

1. SERVO MOTOR MANUFACTURER _____
 AC MODEL NO. / RATED CURRENT / RATED RPM / KW= / CONTINUOUS TORQUE / PEAK TORQUE / SHAFT INERTIA _____
 DC _____
WINDING NO. _____

2. SERVO AMPLIFIER MANUFACTURER _____
 PWM MODEL NO. _____
 SCR OUTPUT VOLTAGE _____

E. MACHINE DATA

1. AXIS (HORIZONTAL / VERTICAL) _____ H / V

2. SLIDE / WAY MATERIAL (STEEL ON STEEL, TURCITE, ETC.) _____

3. SLIDING COEFFICIENT OF FRICTION (SLIDE / WAY – TYPICAL = 0.03, OTHERWISE RANGE = 0.03 TO 0.2) _____ .XX

4. TOTAL WEIGHT OF SLIDE / LOAD _____ LBS.

5. MAXIMUM WEIGHT OF LOAD _____ LBS.

6. MAXIMUM SPEED _____ IN. / MIN

7. ACCELERATION / DECELERATION TIME TO MAXIMUM SPEED _____ SEC.

8. MOTOR / SCREW REDUCER EFFICIENCY (TYPICAL = 0.95) _____ .XX

9. MOTOR / SCREW GEAR RATIO (___ TO 1) _____ MOTOR RPM / SCREW RPM

10. SCREW TYPE _____

11. SCREW EFFICIENCY (TYPICAL = 0.90) _____ .XX

12. SCREW LENGTH _____ IN.

13. SCREW DIAMETER _____ IN.

14. SCREW LEAD _____ IN. / REV

15. APPLIED FORCE OR THRUST _____ LBS.

16. FOR DIRECT DRIVE SYSTEMS - MOTOR TO SCREW COUPLING DIAMETER _____ IN. LENGTH _____ IN.

17. FOR PULLEY DRIVE SYSTEM - MOTOR MOUNTED GEAR DIAMETER _____ IN. LENGTH _____ IN.

18. FOR PULLEY DRIVE SYSTEM - SCREW MOUNTED GEAR DIAMETER _____ IN. LENGTH _____ IN.

19. MOTOR MODIFICATIONS (SEAL, SPECIAL SHAFT, ETC.) _____

20. SPECIFY TIME TO ACHIEVE MAXIMUM SPEED _____ SECONDS

21. RAPID TRAVERSE SPEED _____ IN. / MIN

22. SYSTEM INERTIA REFLECTED TO MOTOR SHAFT _____ LB.-IN.-S²

F. POSITION FEEDBACK

1. TYPE OF FEEDBACK DEVICE RESOLVER ENCODER

2. FEEDBACK DEVICE MOUNTING MOTOR SCREW

3. RESOLUTION AT FEEDBACK DEVICE _____

Leadscrew Application Data for Point to Point Positioning *(Continued)*

G. DUTY CYCLE & TOTAL CYCLE TIME (TRIANGULAR OR TRAPEZOIDAL)

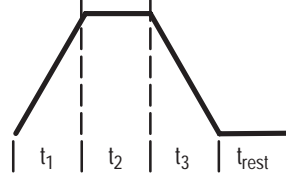
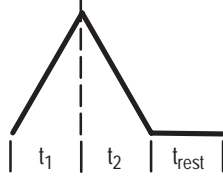

H. ENVIRONMENT (NOTE IF OILY, CORROSIVE, HIGH TEMPERATURE, ETC.)

Leadscrew Application Data for Machine Tool Positioning

A. CUSTOMER _____

B. AXIS DESCRIPTION _____

C. NEW SYSTEM

D. EXISTING EQUIPMENT

1. SERVO MOTOR MANUFACTURER _____
 AC MODEL NO. / RATED CURRENT / RATED RPM / KW= / CONTINUOUS TORQUE / PEAK TORQUE / SHAFT INERTIA _____
 DC _____
WINDING NO. _____

2. SERVO AMPLIFIER MANUFACTURER _____
 PWM MODEL NO. _____
 SCR OUTPUT VOLTAGE _____

E. MACHINE DATA

1. AXIS (HORIZONTAL / VERTICAL) _____ H / V

2. SLIDE / WAY MATERIAL (STEEL ON STEEL, TURCITE, ETC.) _____

3. SLIDING COEFFICIENT OF FRICTION (SLIDE / WAY - TYPICAL = 0.03, OTHERWISE RANGE = 0.03 TO 0.2) _____ .XX

4. TOTAL WEIGHT OF SLIDE / LOAD _____ LBS.

5. MAXIMUM WEIGHT OF LOAD _____ LBS.

6. MAXIMUM SPEED _____ IN. / MIN

7. ACCELERATION / DECELERATION TIME TO MAXIMUM SPEED _____ SEC.

8. MOTOR / SCREW REDUCER EFFICIENCY (TYPICAL = 0.95) _____ .XX

9. MOTOR / SCREW GEAR RATIO (___ TO 1) _____ MOTOR RPM / SCREW RPM

10. SCREW TYPE _____

11. SCREW EFFICIENCY (TYPICAL = 0.90) _____ .XX

12. SCREW LENGTH _____ IN.

13. SCREW DIAMETER _____ IN.

14. SCREW LEAD _____ IN. / REV

15. APPLIED FORCE OR THRUST _____ LBS.

16. FOR DIRECT DRIVE SYSTEMS - MOTOR TO SCREW COUPLING DIAMETER _____ IN. LENGTH _____ IN.

17. FOR PULLEY DRIVE SYSTEM - MOTOR MOUNTED GEAR DIAMETER _____ IN. LENGTH _____ IN.

18. FOR PULLEY DRIVE SYSTEM - SCREW MOUNTED GEAR DIAMETER _____ IN. LENGTH _____ IN.

19. MOTOR MODIFICATIONS (SEAL, SPECIAL SHAFT, ETC.) _____

20. SYSTEM POSITION LOOP GAIN AT CUTTING SPEED _____ IN. / MIN / MIL

21. IF GAIN NOT SPECIFIED, SPECIFY TIME TO ACHIEVE CUTTING SPEED _____ SECONDS

22. SYSTEM POSITION LOOP GAIN ABOVE CUTTING SPEED (0.5 X #6 TYPICAL) _____ IN. / MIN / MIL

23. RAPID TRAVERSE SPEED _____ IN. / MIN

24. SYSTEM INERTIA REFLECTED TO MOTOR SHAFT _____ LB.-IN.-S²

F. POSITION FEEDBACK

1. TYPE OF FEEDBACK DEVICE RESOLVER ENCODER

2. FEEDBACK DEVICE MOUNTING MOTOR SCREW

3. RESOLUTION AT FEEDBACK DEVICE _____

Leadscrew Application Data for Machine Tool Positioning *(Continued)*

G. DUTY CYCLE & TOTAL CYCLE TIME (TRIANGULAR OR TRAPEZOIDAL)

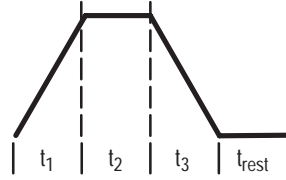
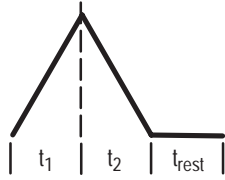

H. ENVIRONMENT (NOTE IF OILY, CORROSIVE, HIGH TEMPERATURE, ETC.)

Rack and Pinion Application Data for Point to Point Positioning

A. CUSTOMER _____

B. AXIS DESCRIPTION _____

C. NEW SYSTEM

D. EXISTING EQUIPMENT

1. SERVO MOTOR MANUFACTURER _____
 AC MODEL NO. / RATED CURRENT / RATED RPM / KW= / CONTINUOUS TORQUE / PEAK TORQUE / SHAFT INERTIA _____
 DC _____
 WINDING NO. _____
2. SERVO AMPLIFIER MANUFACTURER _____
 PWM MODEL NO. _____
 SCR OUTPUT VOLTAGE _____

E. MACHINE DATA

1. AXIS (HORIZONTAL / VERTICAL) _____ H / V
2. TABLE / SLIDE SUPPORT TYPE (ROLLERS, ROLLER BEARINGS, ETC.) _____
3. SLIDING COEFFICIENT OF FRICTION (SLIDE / WAY – TYPICAL = 0.03, OTHERWISE RANGE = 0.03 TO 0.2) _____ .XX
4. TOTAL WEIGHT OF TABLE / LOAD _____ LBS.
5. MAXIMUM TABLE SPEED _____ IN. / MIN
6. ACCELERATION / DECELERATION TIME TO MAXIMUM SPEED _____ SEC.
7. RAPID TRAVERSE SPEED _____ IN. / MIN
8. MOTOR PINION REDUCER EFFICIENCY (TYPICAL = 0.95) _____ .XX
9. MOTOR TO GEARBOX SPEED RATIO (___ TO 1) _____ MOTOR RPM / REDUCER RPM
10. APPLIED FORCE (THRUST) _____ LBS.
11. PINION RADIUS _____ IN.
12. PINION LENGTH _____ IN.
13. PINION TO RACK EFFICIENCY (TYPICAL = 0.95) _____ .XX
14. MOTOR TO GEARBOX COUPLING DIAMETER _____ IN. LENGTH _____ IN.
15. OTHER GEAR / PULLEY DIAMETERS _____ IN. LENGTH _____ IN.
16. PINION MOUNTED SHEAVE / GEAR DIAMETER _____ IN. LENGTH _____ IN.
17. MOTOR MODIFICATIONS (SEAL, SPECIAL SHAFT, ETC.) _____
18. SYSTEM INERTIA REFLECTED TO MOTOR SHAFT _____ LB.-IN.-S²

F. POSITION FEEDBACK

1. TYPE OF FEEDBACK DEVICE RESOLVER ENCODER
2. FEEDBACK DEVICE MOUNTING MOTOR OTHER
3. RESOLUTION AT FEEDBACK DEVICE _____

G. DUTY CYCLE & TOTAL CYCLE TIME _____



H. ENVIRONMENT (NOTE IF OILY, CORROSIVE, HIGH TEMPERATURE, ETC.) _____

Conveyor Application Data

A. CUSTOMER _____

B. AXIS DESCRIPTION _____

C. NEW SYSTEM

D. EXISTING EQUIPMENT

1. SERVOMOTOR MANUFACTURER _____
 AC MODEL NO. / RATED CURRENT / RATED RPM / KW= / CONTINUOUS TORQUE / PEAK TORQUE / SHAFT INERTIA _____
 DC WINDING NO. _____
2. SERVO AMPLIFIER MANUFACTURER _____
 PWM MODEL NO. _____
 SCR OUTPUT VOLTAGE _____

E. MACHINE DATA

1. CONVEYOR LOAD SUPPORT TYPE (BEARING SUPPORTED, ROLLERS, ETC.) _____
2. SLIDING COEFFICIENT OF FRICTION OF SUPPORT (TYPICAL = 0.03) _____ .XX
3. TOTAL WEIGHT OF LOAD / BELT _____ LBS.
4. MAXIMUM SPEED _____ IN. / MIN
5. ACCELERATION TIME TO MAXIMUM SPEED _____ SECONDS
6. MOTOR TO DRIVE ROLL REDUCER EFFICIENCY (TYPICAL = 0.95) _____ .XX
7. GEARBOX RATIO (___ TO 1) _____ MOTOR RPM / GEARBOX RPM
8. NUMBER OF SUPPORT ROLLS _____
9. COUPLING BETWEEN ROLLS (CHAIN, BELT, ETC.) _____
10. ROLL O.D. _____ IN.
11. ROLL I.D. _____ IN.
12. ROLL LENGTH _____ IN.
13. ROLL MATERIAL _____ STEEL / ALUMINUM
14. MOTOR TO GEARBOX COUPLING DIAMETER _____ IN. LENGTH _____ IN.
15. OTHER GEAR / PULLEY DIAMETERS _____ IN. LENGTH _____ IN.
16. MOTOR MODIFICATIONS (SEAL, SPECIAL SHAFT, ETC.) _____
17. SYSTEM INERTIA REFLECTED TO MOTOR SHAFT _____ LB.-IN.-S²

F. POSITION FEEDBACK

1. TYPE OF FEEDBACK DEVICE RESOLVER ENCODER
2. FEEDBACK DEVICE MOUNTING MOTOR OTHER
3. RESOLUTION AT FEEDBACK DEVICE _____

G. DUTY CYCLE & TOTAL CYCLE TIME _____



H. ENVIRONMENT (NOTE IF OILY, CORROSIVE, HIGH TEMPERATURE, ETC.) _____

Conversion Factors

Abbreviations used in this publication are in ().

Torque

<i>To Convert</i>	<i>To</i>	<i>Multiply By</i>
lb.-in.	Newton-meters (N-m)	0.113
lb.-ft.	Newton-meters (N-m)	1.3558
Newton-meters (N-m)	lb.-in.	8.85
Newton-meters (N-m)	lb.-ft.	0.7376
lb.-in.	kg-cm	1.155
lb.-in.	lb.-ft.	0.0833
lb.-ft.	lb.-in.	12
oz.-in.	lb.-in.	0.0625
Joules (J)	lb.-in.	8.85

Temperature

<i>To Convert</i>	<i>To</i>	<i>Use the Formula</i>
degrees F (°F)	degrees C (°C)	(degrees F – 32) / 1.8
degrees C (°C)	degrees F (°F)	(degrees C x 1.8) + 32

Rotation / Rate

<i>To Convert</i>	<i>To</i>	<i>Multiply By</i>
rpm	degrees / second (d / s)	6.00
rpm	radians / second (rad / s)	0.1047
degrees / second (d / s)	rpm	0.1667
radians / second (rad / s)	rpm	9.549
feet / minute (fpm)	meters / second (m / s)	0.00508
feet / second (fps)	meters / second (m / s)	0.3048
inches / second (in. / s)	meters / second (m / s)	0.0254
kmph	meters / second (m / s)	0.2778
rpm	radians / second (rad / s)	0.1047
revolutions	radians (rad)	6.283
radians (rad)	degrees	57.3
degrees	seconds (s)	3600
degrees	minutes (min)	60

Moment Of Inertia

<i>To Convert</i>	<i>To</i>	<i>Multiply By</i>
N-m ²	lb.-ft. ²	2.42
oz.-in. ²	lb.-ft. ²	0.000434
lb.-in. ²	lb.-ft. ²	0.00694
lb.-in. ²	lb.-in.-s ²	0.00259
lb.-ft. ²	lb.-in.-s ²	0.373
Slug-in. ²	lb.-in.-s ²	0.0847
Slug-ft ²	lb.-ft. ²	32.17
oz.-in.-s ²	lb.-ft. ²	0.1675
oz.-in.-s ²	kg-cm ²	73.53
lb.-in.-s ²	lb.-ft. ²	2.68
lb.-in.-s ²	kg-cm-s ²	1.155
lb.-in.-s ²	kg-m ²	0.113
kg-m ²	kg-cm-s ²	10.20
kg-m ²	lb.-ft. ²	23.73
kg-m ²	lb.-in.-s ²	8.85
kg-cm ²	lb.-in.-s ²	0.000885

Mass / Weight

<i>To Convert</i>	<i>To</i>	<i>Multiply By</i>
ounces (oz.)	grams	31.1
pounds (lbs.)	kilograms (kg)	0.4536
pounds (lbs.)	ounces (oz.)	16
kilograms (kg)	pounds (lbs.)	2.205
Newtons	pounds (lbs.)	0.2248
Slugs	Pounds (lbs.)	32.7

Length

<i>To Convert</i>	<i>To</i>	<i>Multiply By</i>
meters (m)	inches (in.)	39.37
meters (m)	feet (ft.)	3.281
meters (m)	yards (yd)	1.094
meters (m)	millimeters (mm)	1000
meters (m)	centimeters (cm)	100
millimeters (mm)	inches (in.)	0.0394
millimeters (mm)	centimeters (cm)	0.10
micrometers (μm)	inches (in.)	0.00003937
inches (in.)	meters (m)	0.0254
inches (in.)	millimeters (mm)	25.4
inches (in.)	centimeters (cm)	2.54
feet (ft.)	meters (m)	0.3048
yards (yd)	meters (m)	0.914

Power

<i>To Convert</i>	<i>To</i>	<i>Multiply By</i>
watts (W)	horsepower (hp)	0.00134
lb.-ft. / min	horsepower (hp)	0.0000303
horsepower (hp)	watts (W)	746

Acceleration

<i>To Convert</i>	<i>To</i>	<i>Multiply By</i>
in. / s ²	m / s ²	0.0254
in. / s ²	g	386.4
ft / s ²	m / s ²	0.3048
ft / s ²	in. / s ²	12
ft / s ²	g	32.2
rad / s ²	Degrees / s ²	57.3

Area

<i>To Convert</i>	<i>To</i>	<i>Multiply By</i>
in. ²	ft ²	0.00694
ft ²	m ²	0.0929
in. ²	m ²	0.000645
in. ³	ft ³	0000579



Allen-Bradley, a Rockwell Automation Business, has been helping its customers improve productivity and quality for more than 90 years. We design, manufacture and support a broad range of automation products worldwide. They include logic processors, power and motion control devices, operator interfaces, sensors and a variety of software. Rockwell is one of the world's leading technology companies.

Worldwide representation.



Argentina • Australia • Austria • Bahrain • Belgium • Brazil • Bulgaria • Canada • Chile • China, PRC • Colombia • Costa Rica • Croatia • Cyprus • Czech Republic • Denmark • Ecuador • Egypt • El Salvador • Finland • France • Germany • Greece • Guatemala • Honduras • Hong Kong • Hungary • Iceland • India • Indonesia • Ireland • Israel • Italy • Jamaica • Japan • Jordan • Korea • Kuwait • Lebanon • Malaysia • Mexico • Netherlands • New Zealand • Norway • Pakistan • Peru • Philippines • Poland • Portugal • Puerto Rico • Qatar • Romania • Russia-CIS • Saudi Arabia • Singapore • Slovakia • Slovenia • South Africa, Republic • Spain • Sweden • Switzerland • Taiwan • Thailand • Turkey • United Arab Emirates • United Kingdom • United States • Uruguay • Venezuela • Yugoslavia

Allen-Bradley Headquarters, 1201 South Second Street, Milwaukee, WI 53204 USA, Tel: (1) 414 382-2000 Fax: (1) 414 382-4444