

134 SPRING STREET / 84 WOOSTER STREET

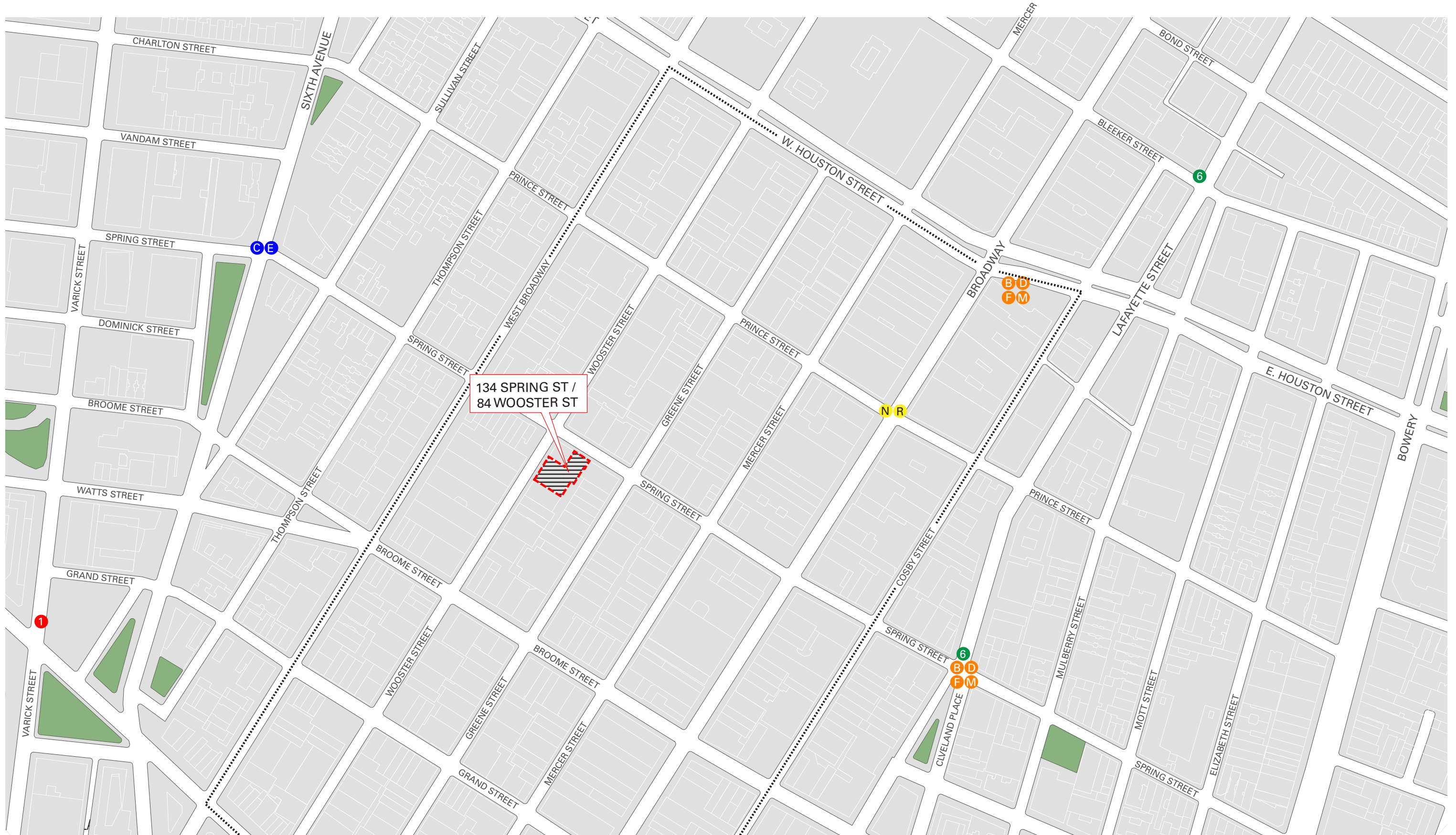

LOCATION MAP



VIEW OF BUILDING



KEY PLAN

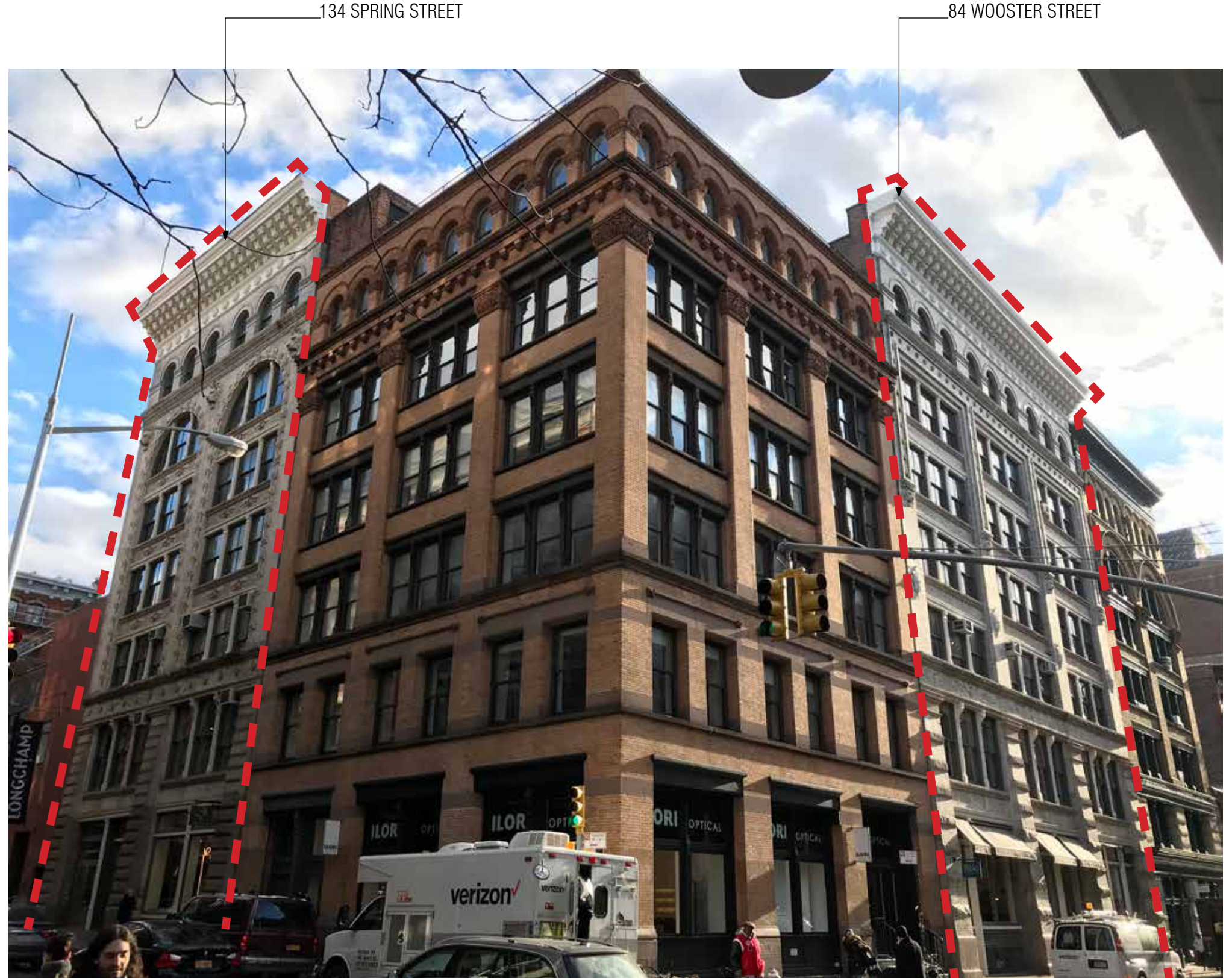

HISTORICAL PHOTOS



84 WOOSTER STREET - 1940'S TAX PHOTO



84 WOOSTER STREET - 1970'S LPC DESIGNATION PHOTO

EXISTING STOREFRONT PHOTOGRAPHS



134 SPRING STREET - EXISTING STOREFRONT



84 WOOSTER STREET - EXISTING STOREFRONT

EXISTING BULKHEAD COMPARISON



134 SPRING STREET
SINGLE PANEL BULKHEAD



84 WOOSTER STREET
DUAL PANEL BULKHEAD

EXISTING STOREFRONT DETAIL PHOTOGRAPHS



EXISTING PAINTED BULKHEAD LOUVER/METAL GRILL WITH PLYWOOD OR DIAMOND PLATE BACKER TO REMAIN



EXISTING WOOD/PLYWOOD BULKHEAD PANEL (NOT HISTORICAL. TO BE REMOVED)



EXISTING HORIZONTAL CAST IRON DETAIL



EXISTING BAY AT 84 WOOSTER - MISSING DECORATIVE CAST IRON SILL. TO BE REPLICATED IN LIKE KIND OUT OF WOOD

84 WOOSTER EXISTING BULKHEAD COMPARISON



84 WOOSTER STREET
WINDOW BAY



EXISTING WOOD BULKHEAD PANEL (TO BE
REMOVED)



EXISTING HORIZONTAL PAINTED TRIM DOES
NOT MATCH OTHER STOREFRONT WINDOW
BAYS WITH CAST IRON TRIM

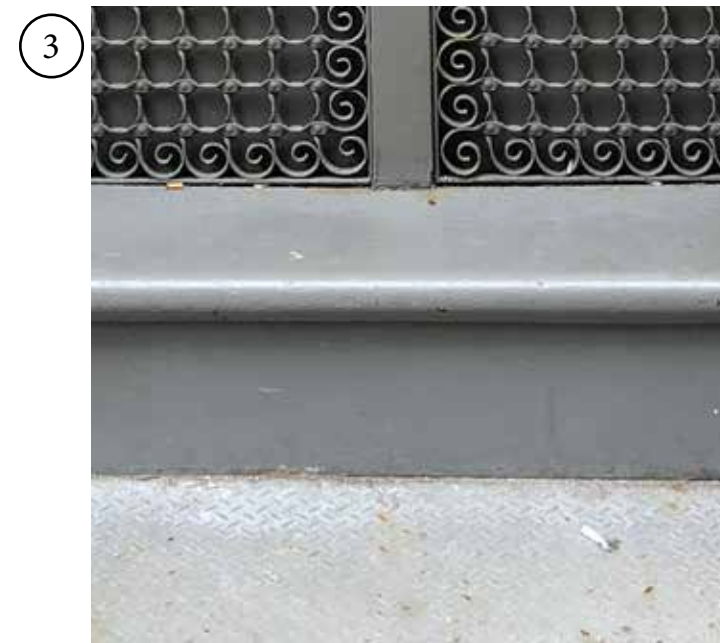

TYPICAL EXISTING PAINTED STEEL STEP AND
DIAMOND PLATE VAULT PANEL TO REMAIN



TYPICAL EXISTING HORIZONTAL CAST IRON
DETAIL

SINGLE PANEL BULKHEAD PRECEDENTS



131 SPRING STREET



80 WOOSTER STREET



77 WOOSTER STREET



72 WOOSTER STREET



71 WOOSTER STREET

EXISTING FULL BUILDING ELEVATIONS

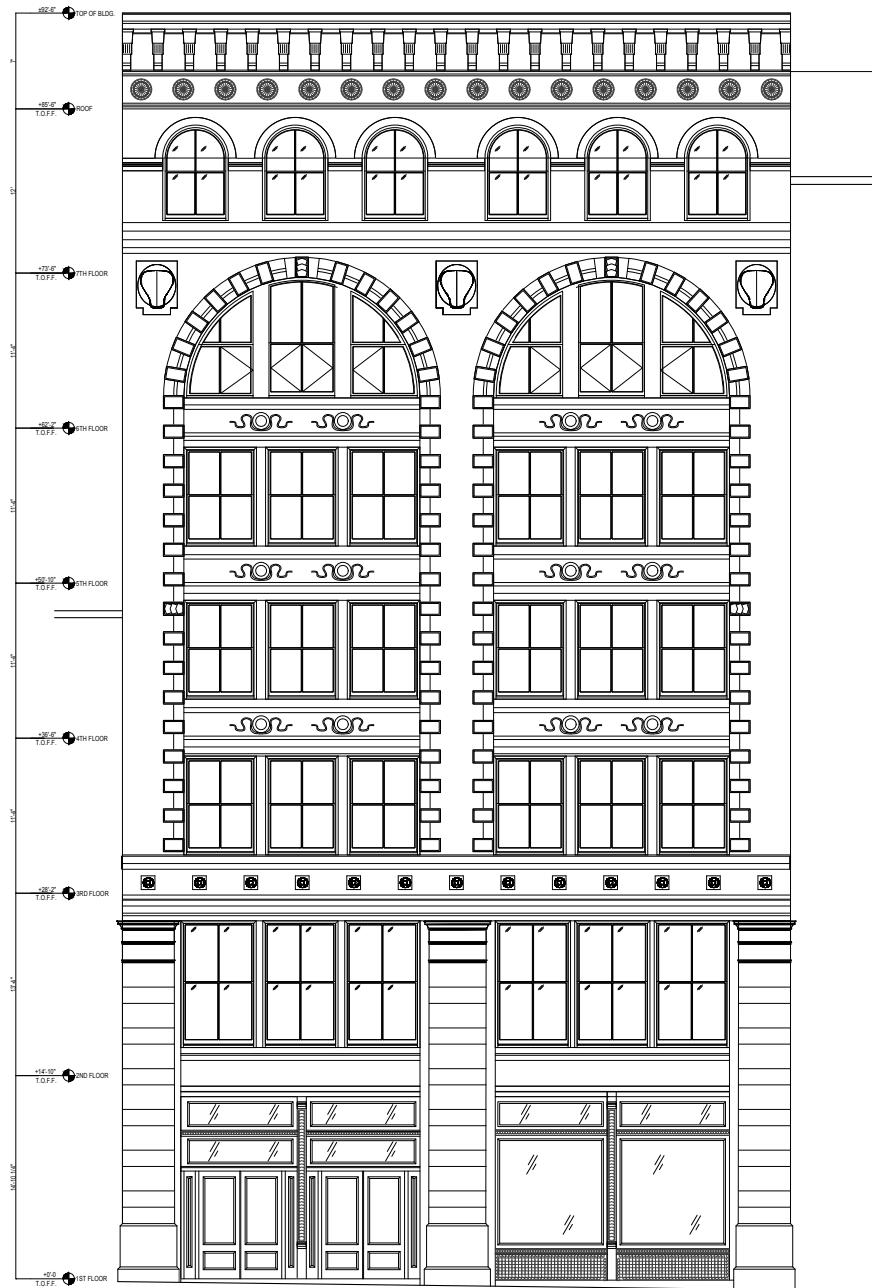

134 SPRING STREET FACADE

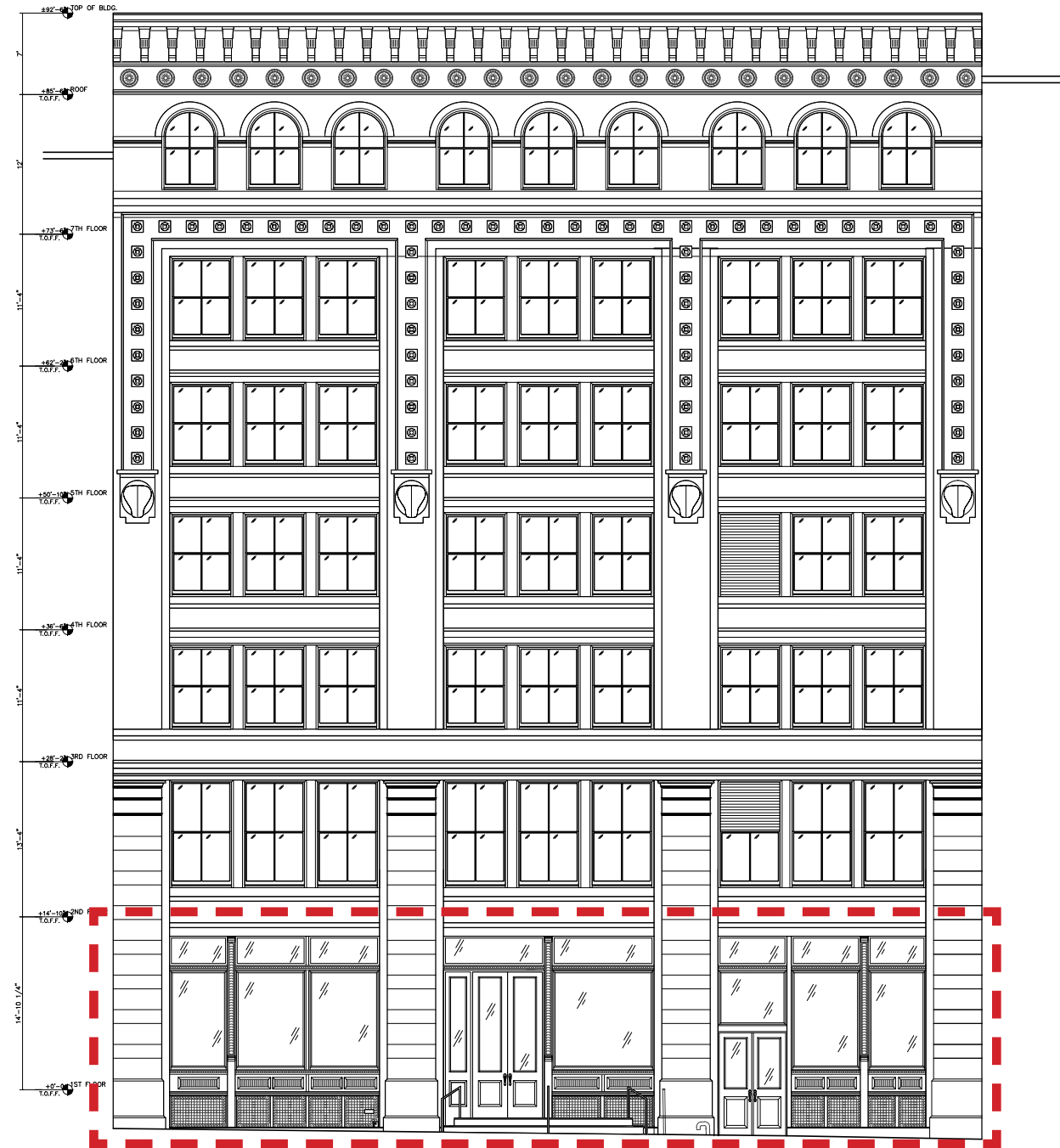

84 WOOSTER STREET FACADE

EXISTING BUILDING STOREFRONT ELEVATIONS



134 SPRING STREET EXISTING STOREFRONT ELEVATION

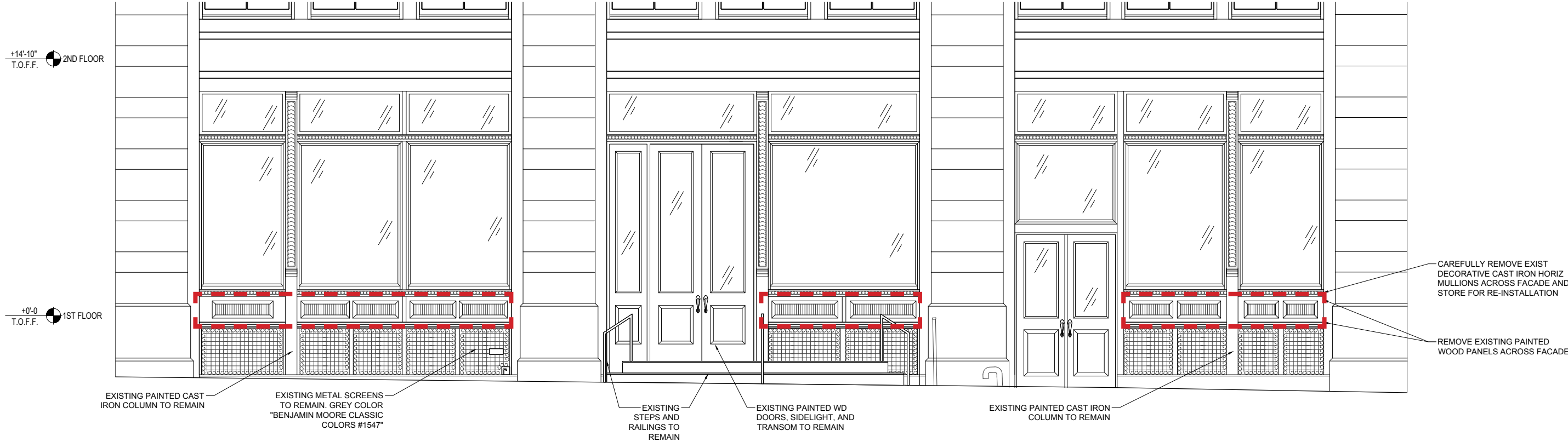

84 WOOSTER STREET EXISTING STOREFRONT ELEVATION

EXISTING VS PROPOSED WOOSTER STOREFRONT



EXISTING STOREFRONT ELEVATION



PROPOSED STOREFRONT ELEVATION

STOREFRONT PHOTOGRAPHS & PROPOSED RENDERING



REMOVE BULKHEAD INFILL PANEL

EXISTING STOREFRONT



VERTICALLY ENLARGE SINGLE PANE WINDOW & FABRICATE NEW TRIM PIECE.

PROPOSED STOREFRONT

PROPOSED STOREFRONT ELEVATION & PLAN



PROPOSED STOREFRONT ELEVATION

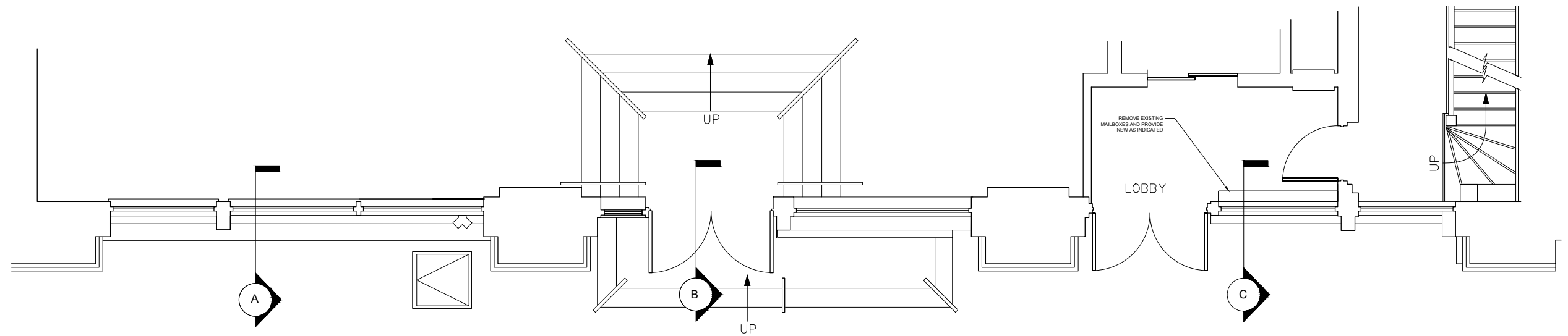

PLAN

PROPOSED STOREFRONT ELEVATION & PLAN

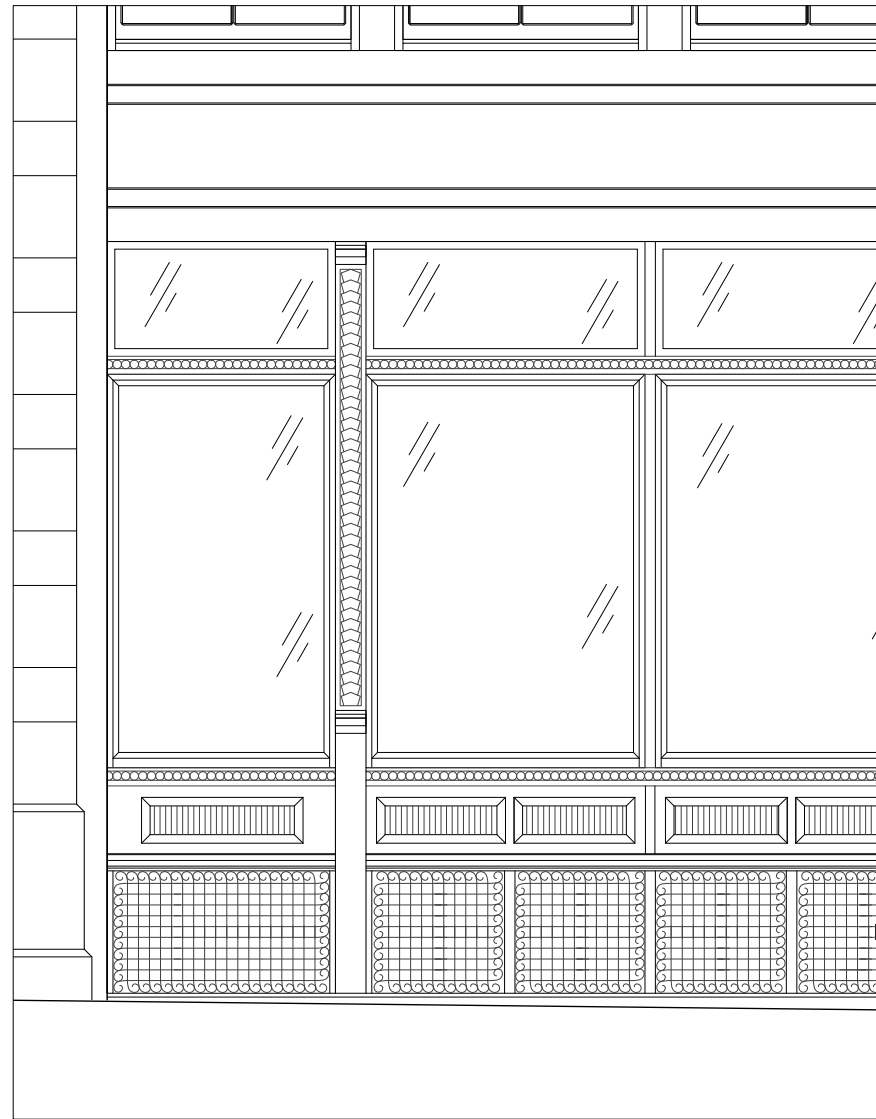

EXISTING CONDITION

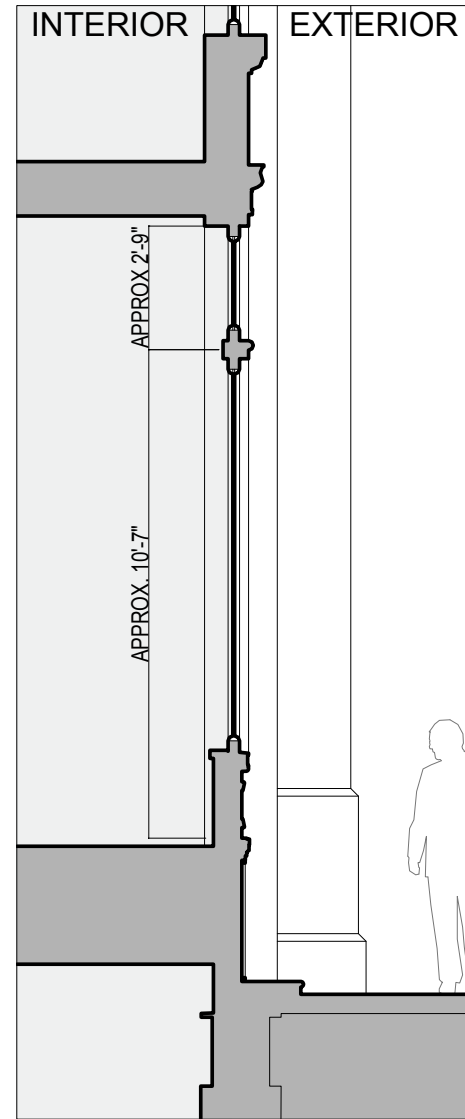

SECTION A

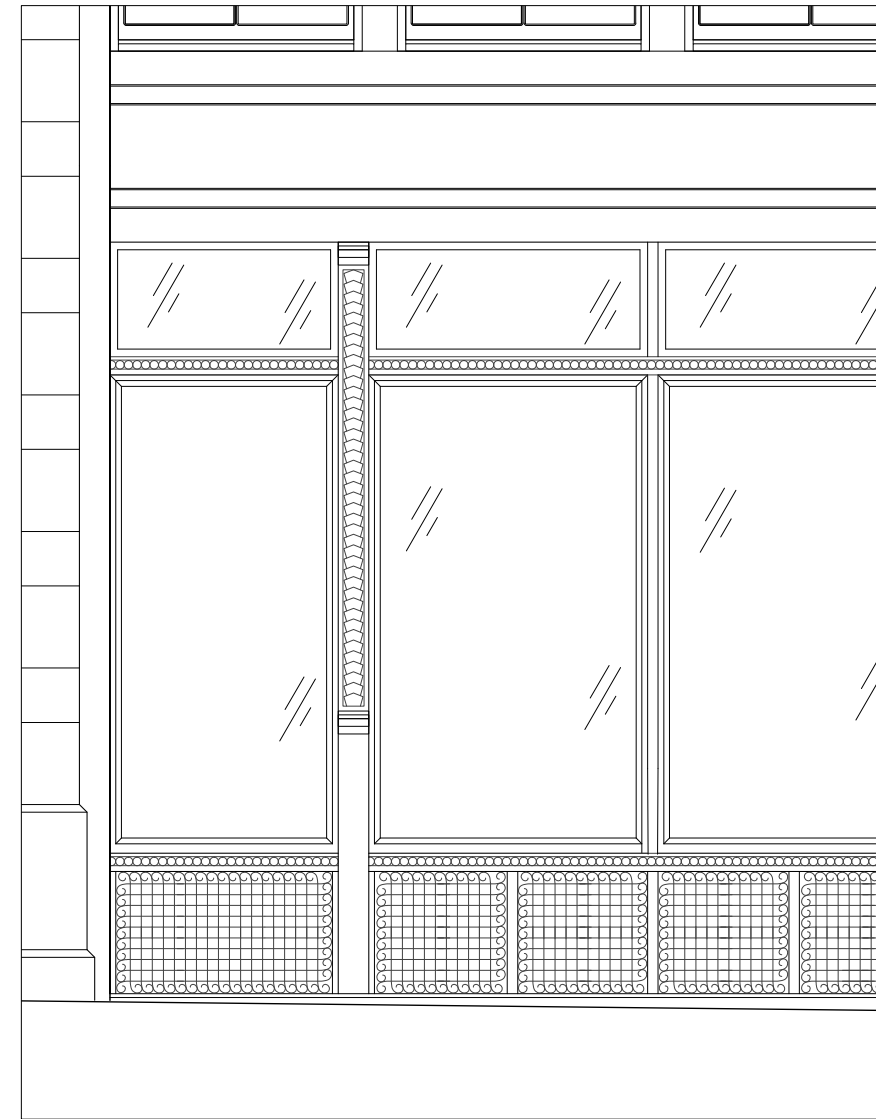

PROPOSED CONDITION

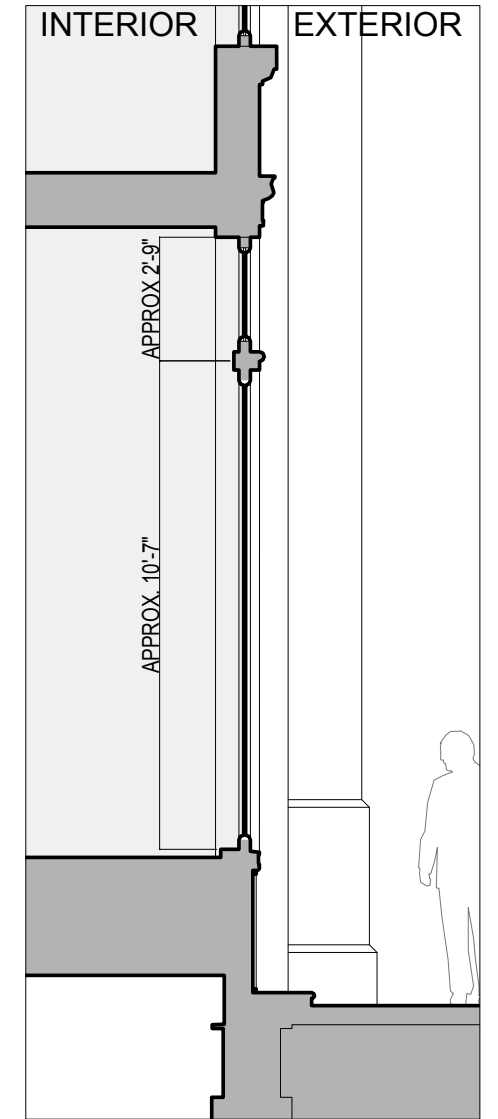

SECTION A

STOREFRONT SECTIONS & DETAILS

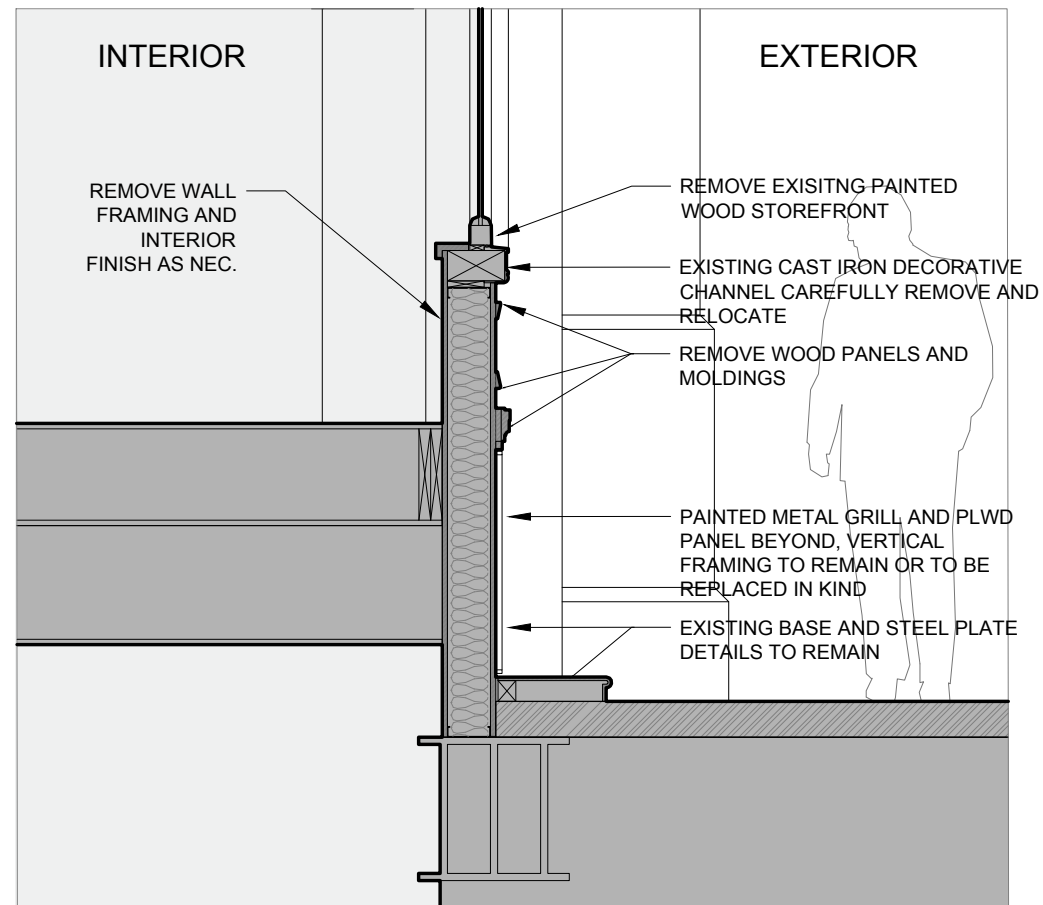

EXISTING CONDITION
SECTION A

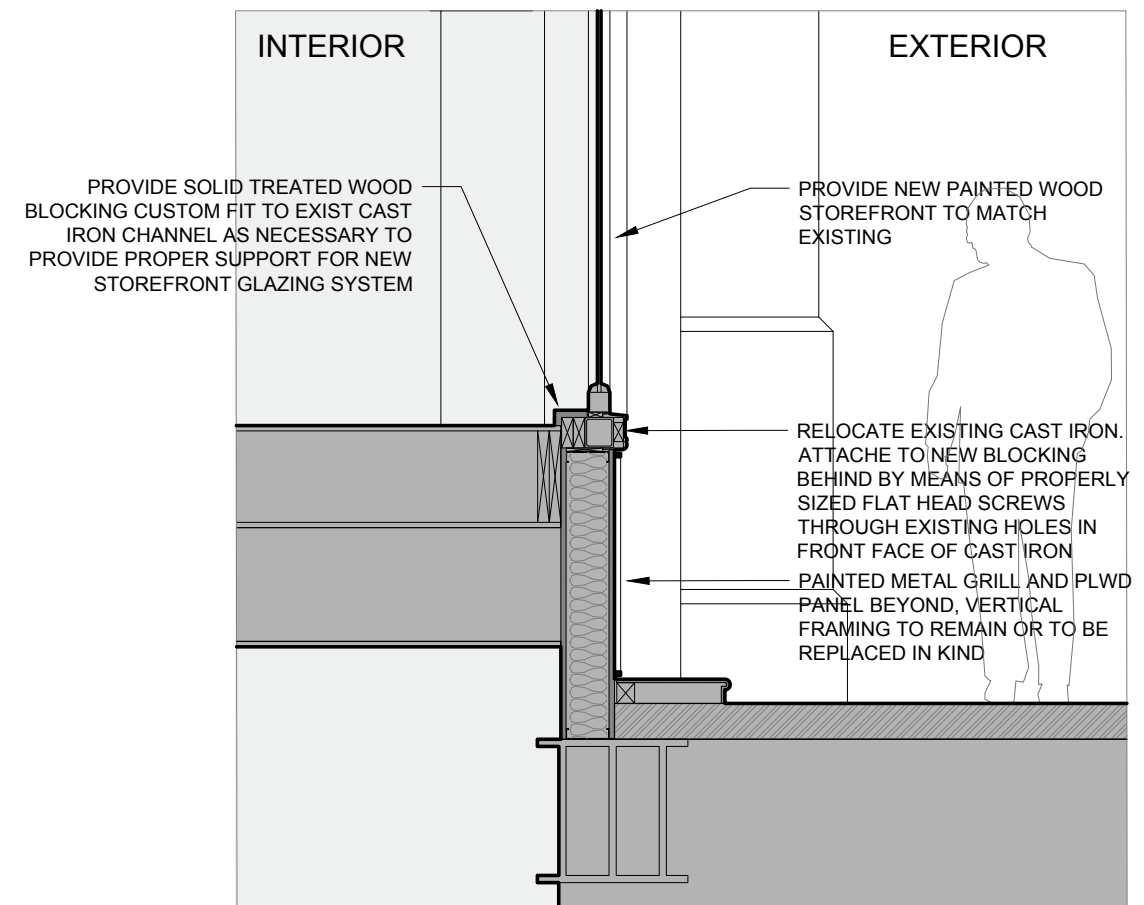

PROPOSED CONDITION
SECTION A

EXISTING CONDITIONS -PROBE PHOTOS

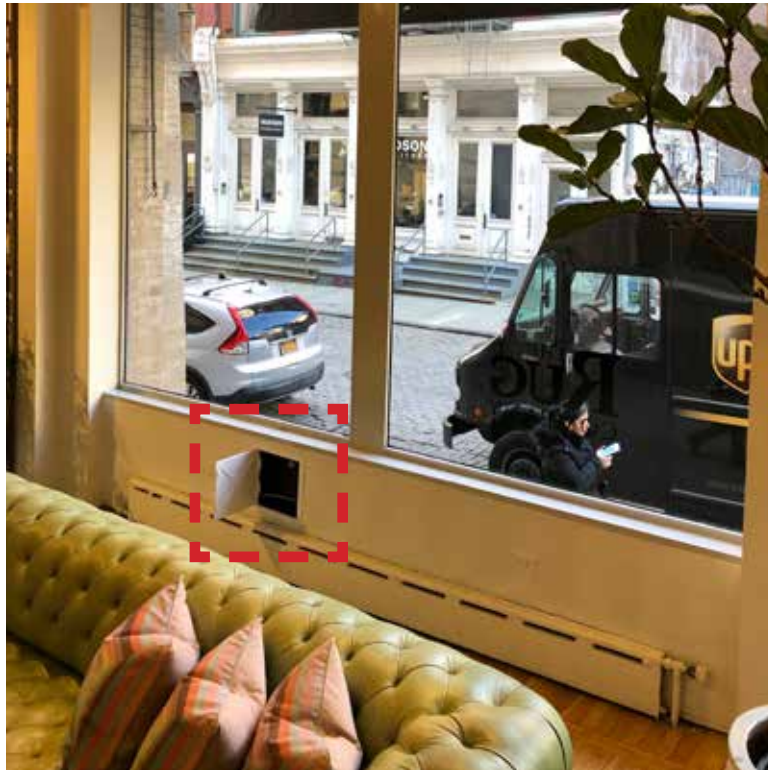

INTERIOR CONTEXT LOCATION PHOTO



WALL ASSEMBLY DETAIL PHOTO

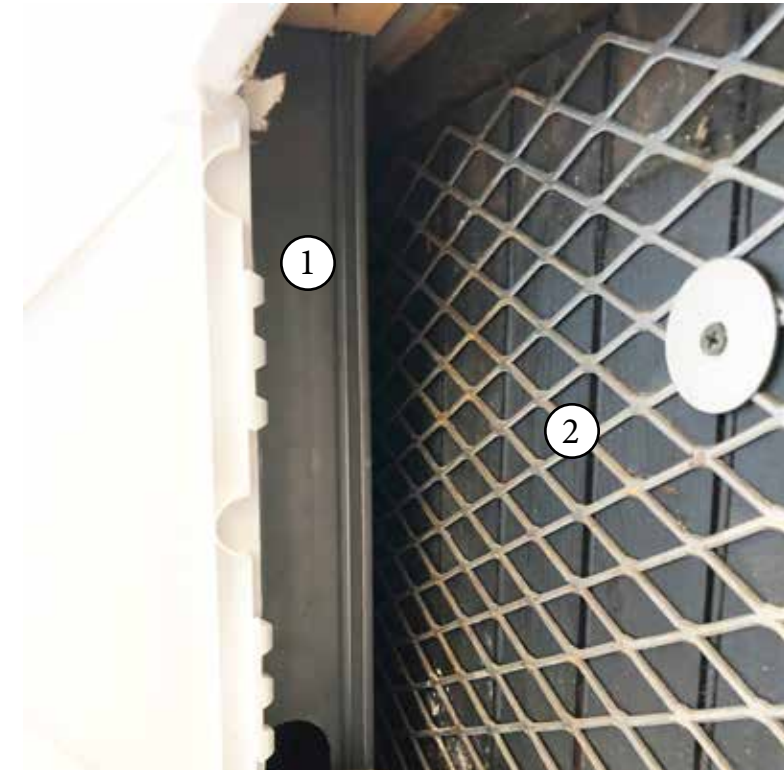

WALL ASSEMBLY DETAIL PHOTO

- ① NEW STEEL STUD CONSTRUCTION (NOT ORIGINAL)
- ② MODERN PLYWOOD BEADBOARD AND STEEL LATH.



EXTERIOR CONTEXT LOCATION PHOTO



WALL MATERIAL DETAIL PHOTO



WALL MATERIAL DETAIL PHOTO

- ① PLYWOOD BEADBOARD AND TRIM ATTACHED TO NEW STEEL STUD. (NOT ORIGINAL)

134 SPRING STREET / 84 WOOSTER STREET



STOREFRONT LOBBY ELEVATION & SECTION

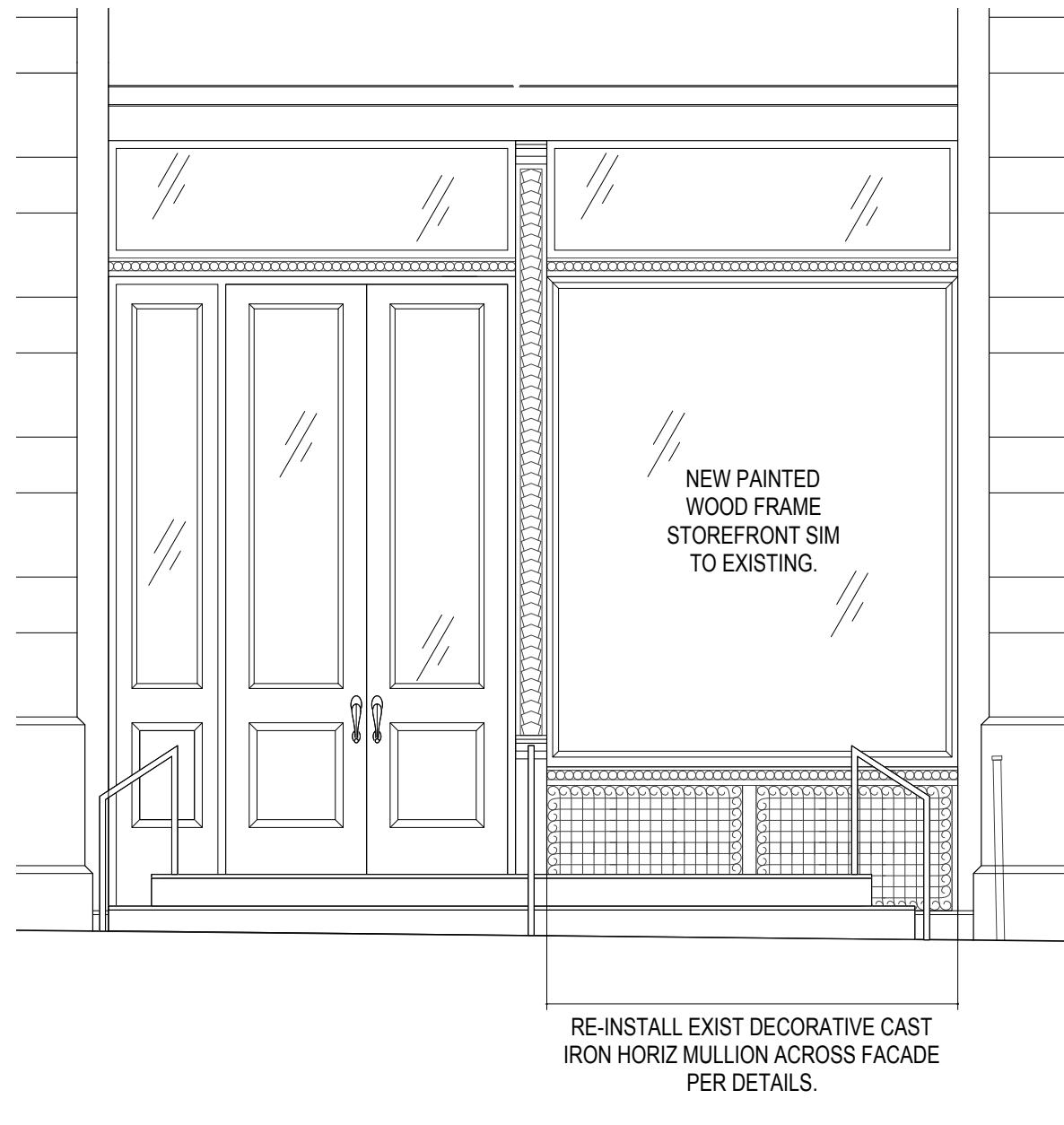

RETAIL LOBBY ELEVATION

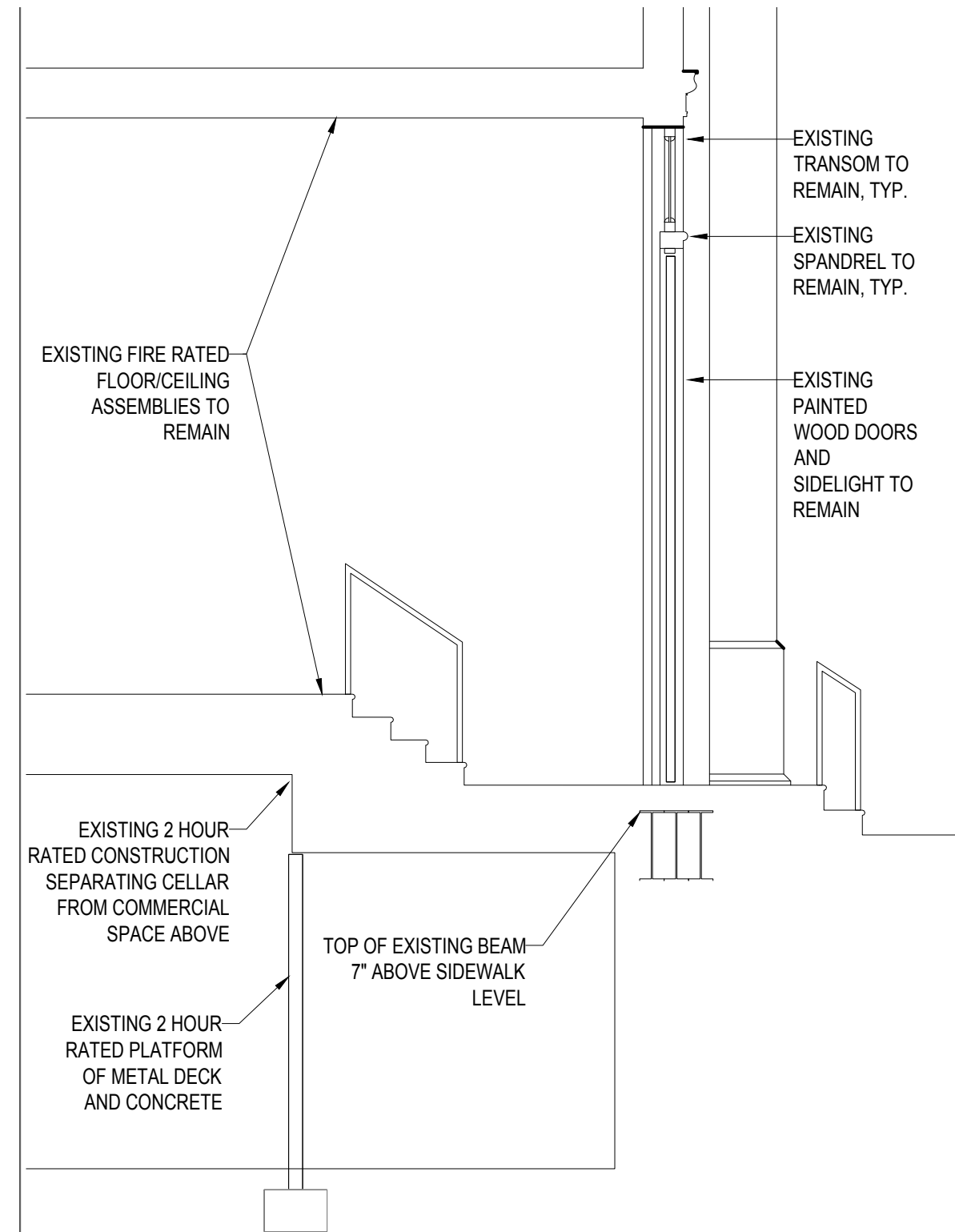

RETAIL LOBBY SECTION

STOREFRONT LOBBY SECTIONS & DETAILS

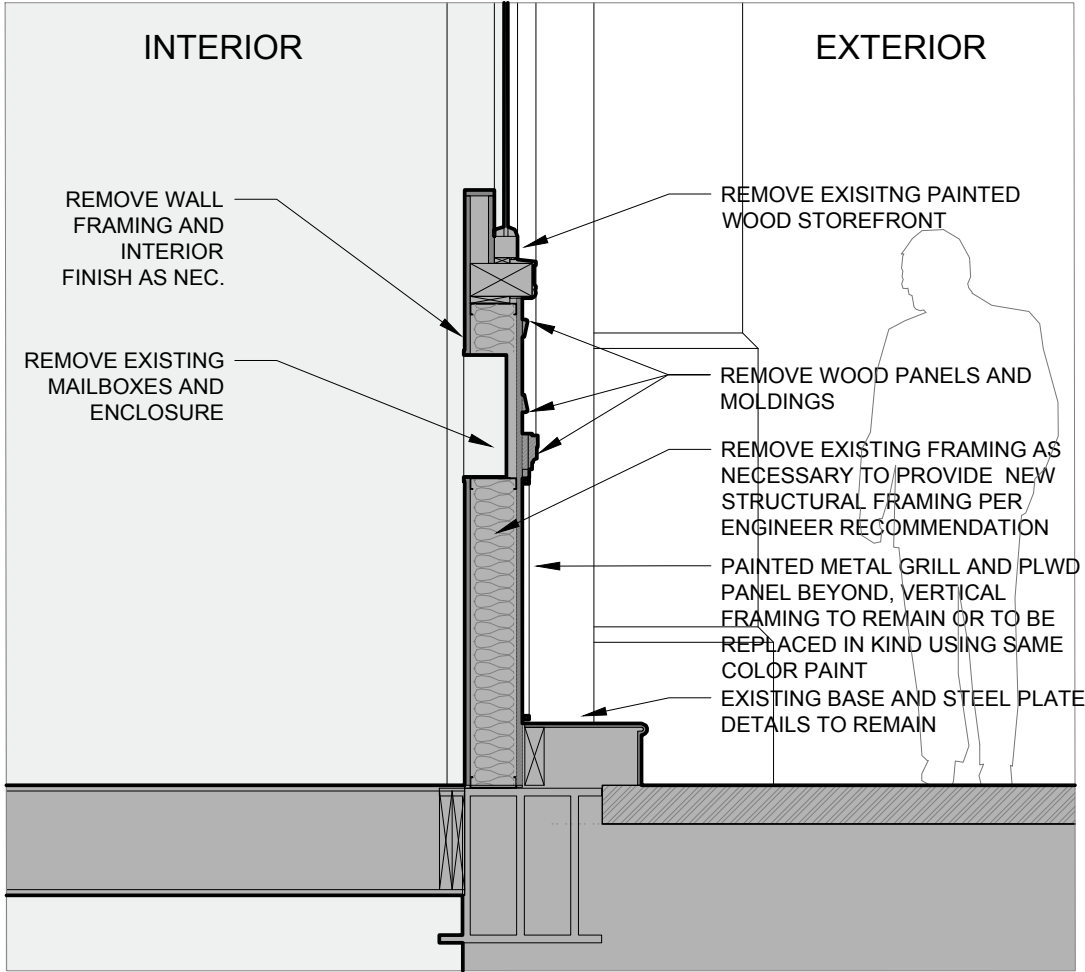

EXISTING CONDITION
SECTION C

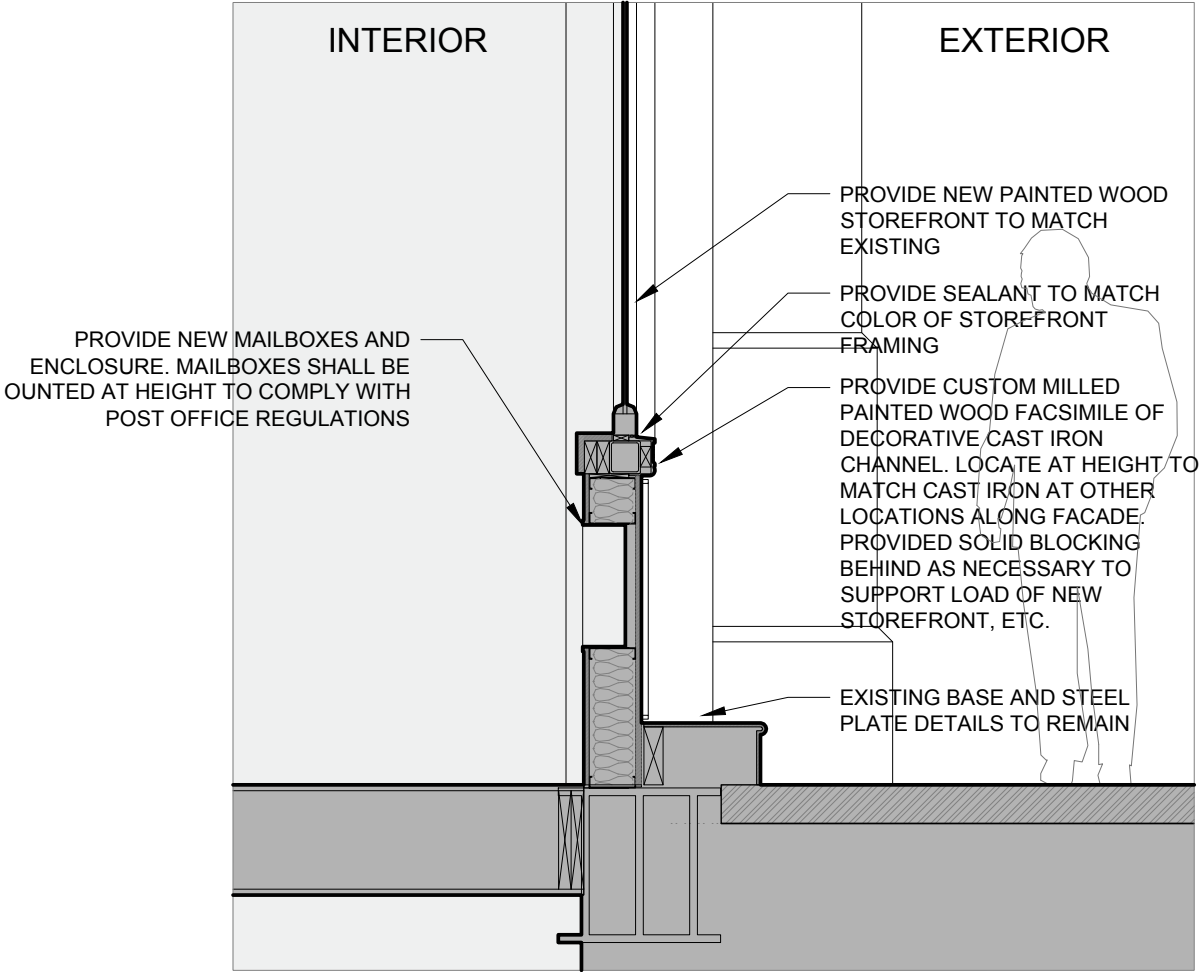

PROPOSED CONDITION
SECTION C

CAST IRON DETAIL



PHOTO OF EXISITING HORIZONTAL CAST IRON TRIM

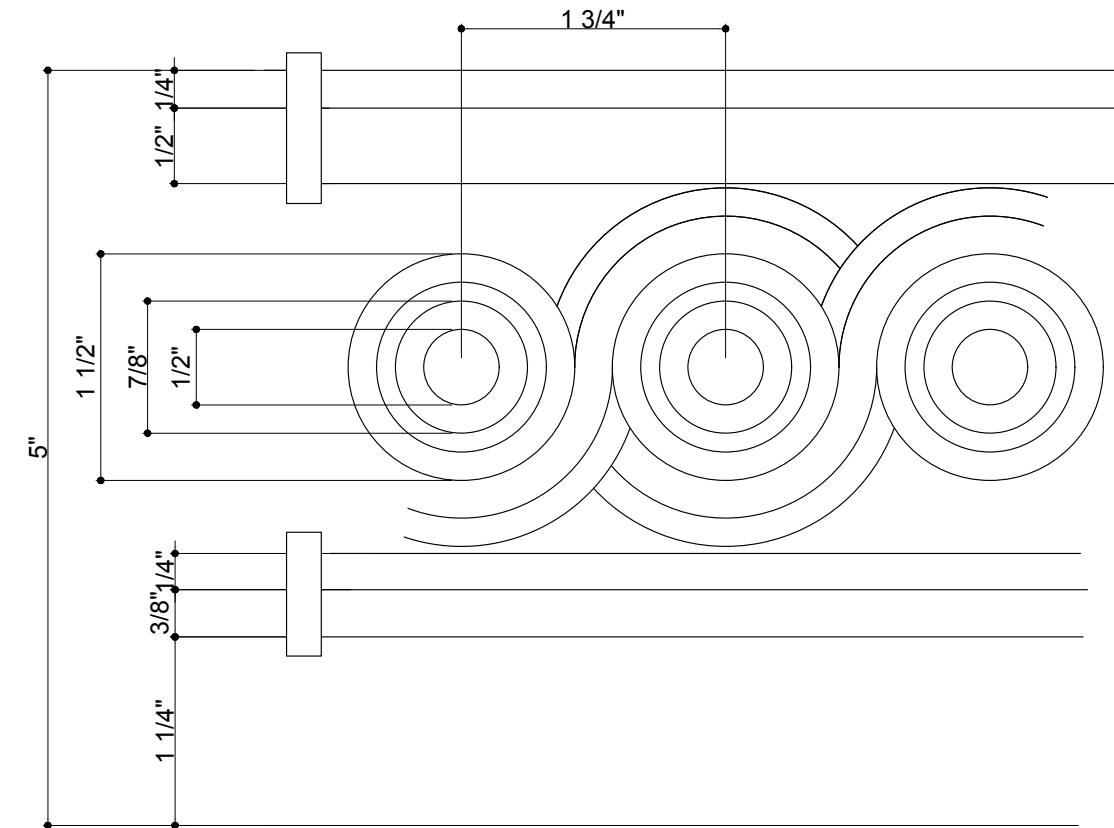
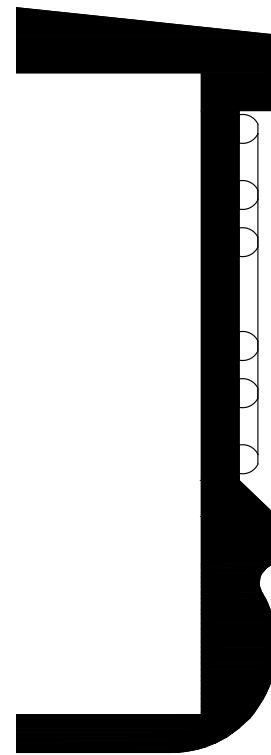

TYPICAL EXISITING HORIZONTAL CAST IRON DETAIL