



MK-370 SERIES

TILE SAW OWNER'S MANUAL & OPERATING INSTRUCTIONS



- For your own safety read instructions manual before operating saw
- Wear eye protection
- Use splash hood for every operation for which it can be used
- Disconnect saw before servicing, when changing cutting wheels, and cleaning
- Use tool only with smooth edge cutting wheels free of openings and grooves
- Replace damaged cutting wheel before operating



Enter the Serial Number of your new saw in the space below. The Serial Number is located on the left side of the blade guard.

SERIAL NUMBER:

NOTE:

For your (1) one year warranty to be effective, complete the warranty card (including the Serial Number and mail it in as soon as possible.

EXPLODED VIEW AND PARTS LIST

EXPLODED VIEW:

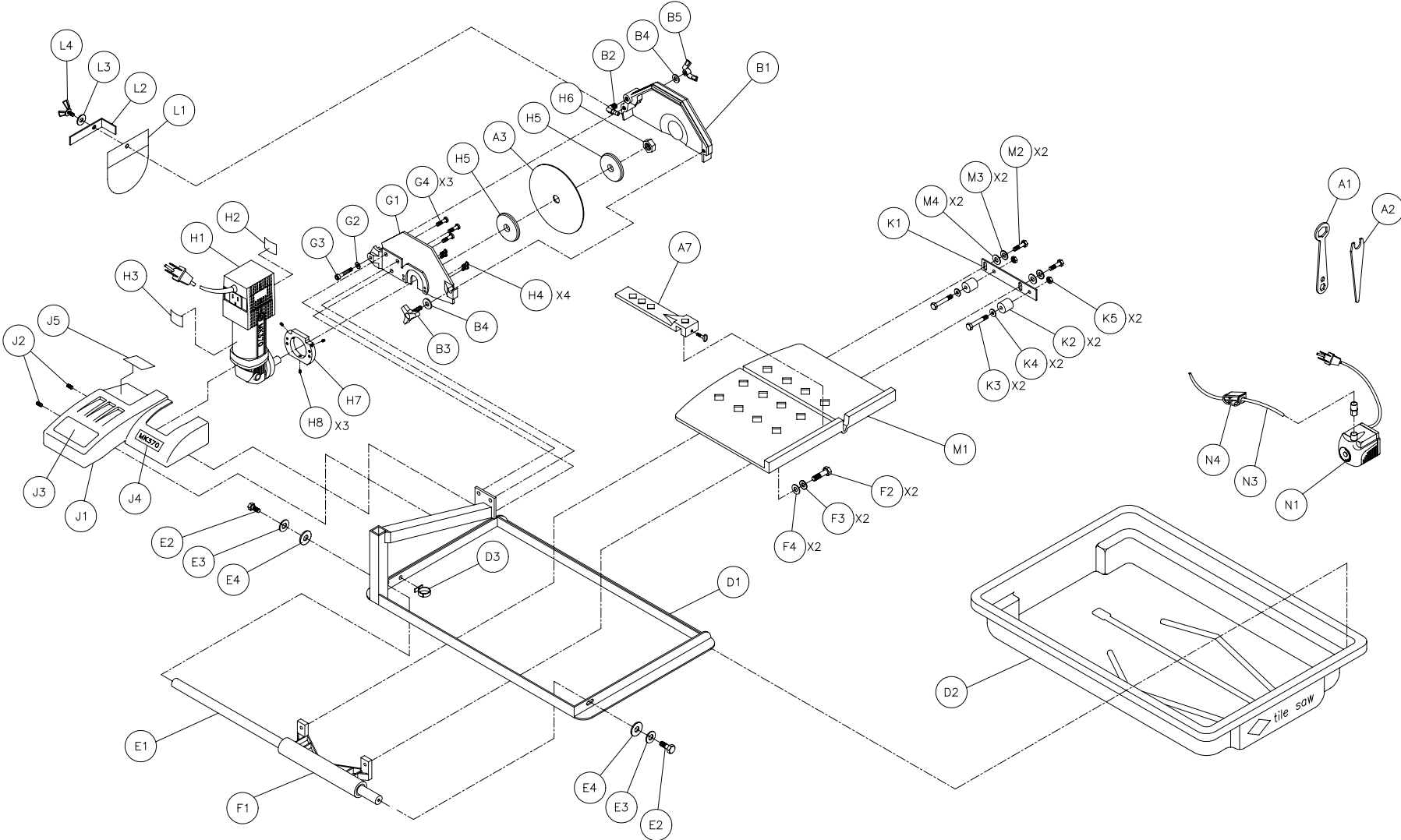

EXPLODED VIEW AND PARTS LIST

PARTS LIST:

Item	Description	Qty	Part #
A	Accessories	-	n/a
A1	Wrench, Blade Nut, 15/16 Boxed End	1	134684
A2	Wrench, Blade Shaft, 11/16 Open End	1	153450
A3	Blade, 7 Dia X 5/8 arbor	1	153441
A4	Owner's Manual, 370	1	156760
A5	Warranty Card	1	155037
A6	Tag, Saw Hang, 370	1	156750
A7	Assembly, Rip Guide	1	134551-MK
B	Assembly, Blade Guard, 7"	1	154811-MK
B1	Guard, 7" Blade	1	154811
B2	Elbow, 1/8 MNPT X 1/4 BARB 90° Brass	1	154652
B3	Knob, Davies	1	151681
B4	Washer, 5/16 SAE Flat	2	151754
B5	Wingnut, 5/16-18 Nylock	1	151746
D	Frames	-	n/a
D1	Frame	1	155792
D2	Pan, Water	1	155791
D2A	Pan, Water, Deep	1	157210
D3	Cord Clip, 1/4 Push Mount	1	157259
E	Assembly, 5/8 Guide Bar	1	151739-MK
E1	Bar, Guide, 5/8 Dia	1	151739
E1A	Bar, Guide, 5/8 Dia, Extended	1	157486
E2	Screw, 5/16-18 X 1 Hex Head Cap	2	151743
E3	Washer, 5/16 Split Lock	2	151747
E4	Washer, 5/16 SAE Flat	2	151754
F	Linear Bearing	-	n/a
F1	Bearing, Linear, 5/8 Dia (comp)	1	157126
	F1A Bearing, Multitube	2	151781
F2	Screw, 5/16-18 X 1 Hex Head Cap	2	151743
F3	Washer, 5/16 Split Lock	2	151747
F4	Washer, 5/16 SAE Flat	2	151754
G	Assembly, Motor Mount	1	155811-MK
G1	Motor Mount	1	157403
G2	Washer, 5/16 Split Lock	1	151747
G3	Screw, 5/16-18 X 2 1/2 Hex Head Cap, Full Thread	1	151748
G4	Screw, 1/4-20 X 1/2 Flat Head Phillips Cap	3	155812
H	Motors	-	n/a
H1	Motor, 120v/7.4a, 370	1	156428-R
H2	Label, Caution, GFCI, 1 X 2 1/8	1	155678
H3	Label, Caution, Receptacle, 1 X 2 1/8	1	154822
H4	Screw, 10-32 X 5/8 Flat Head Phillips Cap,	4	157554
H5	Flange, Blade	2	135830
H6	Nut, 5/8-18 UNF	1	135848
H7	Adapter, Motor, 370	1	156703
H8	Screw, 10-32 X 1/4 Socket Head Set, Cup Point	3	156715

EXPLODED VIEW AND PARTS LIST

Item	Description	Qty	Part #
H9	Label, 370 Model	1	156692
H10	Plug, CEE 7/7 16a 240v	1	153687
J	Post Cover	-	n/a
J1	Casting, Cover, Post, 370	1	156748
J2	Screw, 10-24 X 3/8 Socket Head Set, Cup Point	2	156715
J3	Label, Warning, Read Owner's Manual	1	155806
J4	Label, 370 Model	1	156692
J5	Label, Serial Number, UL/CSA Mark	1	157249-04
K	Assembly, Roller Wheel, Double	1	156586
K1	Bracket, Roller Wheel	1	156522
K2	Wheel, Roller	2	151799
K3	Screw, 1/4-20 X 1 1/2 Hex Head Cap	2	151914
K4	Washer, 1/4 SAE Flat	2	151915
K5	Nut, 1/4-20 Hex	2	151893
L	Assembly, Splash Curtain	1	155901-MK
L1	Curtain, Splash	1	134841
L2	Bracket, Splash Curtain	1	155901
L3	Washer, 1/4 SAE Flat	1	151915
L4	Wingscrew, 1/4-20 X 1/2	1	151888
M	Table	-	n/a
M1	Table, Composite, 370/470	1	156536
M2	Screw, 5/16-18 X 1 Hex Head Cap	2	151743
M3	Washer, 5/16 Split Lock	2	151747
M4	Washer, 5/16 SAE Flat	2	151754
N	Assembly, PES-100 120v Water Pump	1	155987-MK
N1	Pump, Water, PES-100 120v	1	155987
N1A	Pump, Water, 100v	1	154812
N1B	Pump, Water, 230v	1	156181
N3	Hose, Vinyl, 1/4 ID	2'	132951
N4	Clamp, Flow, 1/4-1/2	1	154394
N5	Owner's Manual, Water Pump	1	155745

EXPLODED VIEW AND PARTS LIST

RYOBI MOTOR EXPLODED VIEW:

MK-370

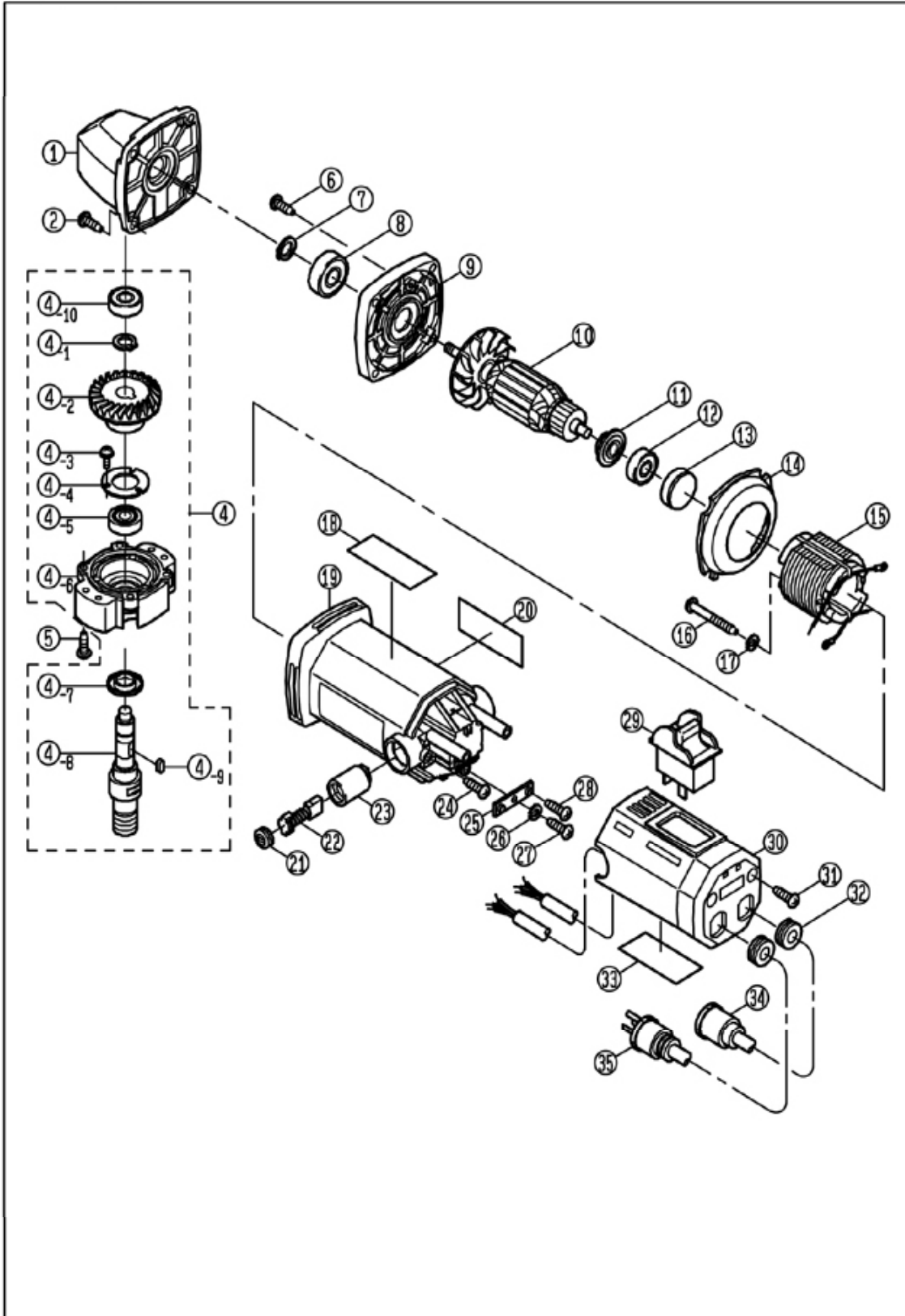

EXPLODED VIEW AND PARTS LIST

RYOBI MOTOR PART LIST:

Item	Description	Qty	Part #
1	GEAR SHAFT	1	6110298
2	PARALLEL KEY 5X5X14	1	6100224
3	GEAR CASE COVER	1	6821489
4	FLAT TAPPING SCREW (S) M4X12	4	9150412
5	WASHER t=1.6	1	6901213
6	BALL BEARING #6203LLH	1	9896203
7	BEARING PLATE t=1.6	1	6155821
8	TAPPING SCREW (S) M4X10	4	9040410
9	COLLAR	1	6900120
10	FINAL GEAR	1	6200907
11	RETAINING RING S-17	1	9511700
12	BALL BEARING #6001LLB	1	9846001
13	GEAR CASE	1	6821486
14	BUSH	1	6760285
15	O RING S-35	1	6930245
16	BALL BEARING #6202LLB	1	9846202
17	WASHER t=1.6	1	6901212
18	O-RING P-16	1	9760016
19	ARMATURE 120V	1	6034942
20	FAN CASING	1	6490464
21	FIELD COIL 120V	1	6502980
22	TAPPING SCREW (B) M5X75	2	9060575
23	DUST COLLAR	1	6901211
24	BALL BEARING #6200LLB	1	9846200
25	BEARING HOUSE	1	6190868
26	O RING S-30	1	6930247
27	MOTOR HOUSING	1	6803938
28	NAME PLEAT 120V	1	6917563
29	SPRING WASHER M6	4	9550600
30	PHILLIPS PAN SCREW M6X25	4	9000625
31	TAPPING SCREW (S) M4X14	2	9040414
32	TAPPING SCREW (B) M4X16	2	9060416
33	BRUSH HOLDER	2	6570133
34	CARBON BRUSH 613GN	1	6541667
35	BRUSH CAP	2	6570134
500	FLANGE	1	6940756
501	HEX BOLT M10X20	1	6131616
502	WASHER 10.5X21X2	1	9571000
503	SINGLE-END WRENCH 17	2	6240533