



16341-E

Pad Mounted Interrupter Switches

This document provides design standards only, and is not intended for use, in whole or in part, as a specification. Do not copy this information verbatim in specifications or in notes on drawings. Refer questions and comments regarding the content and use of this document to the Yale University Project Manager.

CONTENTS

- A. [Summary](#)
- B. [References](#)
- C. [System Design and Performance Requirements](#)
- D. [Submittals](#)
- E. [Product Standards](#)
- F. [Manufacturers](#)
- G. [Equipment](#)
- H. [Accessories or Special Features](#)
- I. [Extra Materials](#)
- J. [Installation Guidelines](#)
- K. [Quality Control](#)
- L. [Cleaning and Adjusting](#)

A. Summary

This section contains design criteria for medium voltage pad mounted interrupter switches and protective devices.

B. References

1. ANSI C37.57 Metal-Enclosed Interrupter Switchgear Assemblies – Conformance Testing
2. ANSI C37.72, 1987 Standard for Medium AC Pad Mounted Switches for Use in Metal-Enclosed Interrupter Switchgear
3. ANSI C57.12.28, 2005 Standard for Pad Mounted Equipment
4. ANSI/IEEE 386 standard for separable insulated connector systems for power distribution systems above 600 V



C. System Design and Performance Requirements

1. Switches shall be manually operated, load interrupting, SF6 gas insulated, dead front secondary distribution type, non-ventilated, tamperproof and weatherproof, and suitable for mounting on a concrete pad for buried cable entrance and exit. There shall be no energized parts exposed to the environment or surrounding personnel. There shall be no exposed screws, bolts or other externally removable fastening devices. There shall be no openings through which foreign objects, such as sticks, rods, or wires might be inserted to contact live parts.
2. Enclosure shall be minimum 12 gauges mild steel manufactured to ANSI C37.72 and C57.12.28 standards. The enclosure shall be mounted independent of and separately removable from the switch tank to allow independent replacement of the switch tank. Include four enclosure lifting provisions. Enclosure shall be tamper-resistant incorporating hinged access door to the cable entry and switch compartment with stainless steel and brass fasteners and three point latch and penta-head locking bolts and provision for a single padlock. Approximate enclosure dimensions are: 54" wide x 48"; deep x 46" high. Weight with gas: 750 lbs.
3. Switch Tank: The switches shall be contained in hermetically sealed tank construction. The tank shall be minimum 12 gauge welded stainless steel, factory filled with SF6 gas and sealed for the life of the unit. Tank shall be designed to withstand 15 psig internal pressure and an external pressure of 14 psig without affecting performance of the switch. Include viewing windows for each switch position.
4. Switch construction: Switches shall be designed for front access to cables and operators. The multi-position switch operating mechanism shall be externally hook-stick-operated only with door opened. Equip each switching way with an internally mounted operating mechanism capable of providing quick-make, quick-break operation in either switching direction. Switch positions shall be clearly identified, padlockable and adaptable to keylock schemes. Switch contacts shall be tulip-bayonet design using high conductivity copper alloy and clearly visible in the open position through the viewing windows. Contacts shall be designed such that arcing does not occur in the area of main current flow at the closed position and so contact pressure increases with increased current flow. Auxiliary blades used for load interruption are not acceptable. Unit shall be designed to accept two incoming radials with the provisions of a close transition for maintenance purposes.



5. Ratings:

- a. High voltage BIL: 110 kV
- b. Maximum Design Voltage: 15.5 kV
- c. Continuous & Loadbreak Amps: 600
- d. 1 Minute Withstand, AC kV: 34
- e. 15 Minute Withstand, DC kV: 53
- f. Momentary Current, kA Symmetrical: 40
- g. Fault-close, kA Asymmetrical: 40
- h. Ten (10) Operation Overload Interrupt Capability, A: 3000
- i. Load Interrupter Endurance @ 600A, Operations: 1200
- j. Maximum Gas Leakage Test, cc-atm/second: 1×10^{-7}

6. Cable Entrances & Bushings

- a. Cable enhances shall conform to ANSI/IEEE 386 consisting of 600 ampere deadbreak bushings 1200 ampere loadbreak bushings complete with parking stands for use with separable connectors, 125 kV BIL. Bushings shall be bolted, gasketed enhance type. Ensure compatibility with the termination connectors normally used by the Owner on campus. Bushing configuration: Diagonal Take-off.

7. All electrical equipment receiving 15 kV underground campus radial feeds shall have a minimum lug size of 500 MCM.

8. All medium-voltage switchgear shall be grounded in two (2) locations, forming two (2) separate ground paths. All ground conductors shall not be smaller than size #4/0 AWG copper wire.

9. Finishes shall be prepared with solvent wash to remove rust, oil and grease. Primer coat tank and enclosure with 2 mils dry finish, ASA 70 light gray primer and final coat with a Munsell No. 7.OGY-3.2911.5 green finish using corrosion resistant epoxy paint, 3 mils thick, minimum.

10. Vacuum Interrupter Electronic Control



- a. Provide an electronic assembly to sense load and fault current on each phase of the load tap circuits. The electronic control shall be powered from the current transformers mounted inside the SF6 insulated switch tank. No external power source shall be required for overcurrent protection. The electronic control shall monitor the current on the individual phases of the load tap circuits using input from the internal current transformers. Electronic trip capability shall be selectable for each phase. Temperature range shall be -30 degree C to +50 degree C.
- b. Minimum trip selection shall be accomplished with selector knobs inside the electronic enclosure. Trip time current characteristics (TCC) shall be field selectable using a dip switch. Maximum time for power up and ready-to-trip when closing on a circuit shall be ten percent of the trip time or 112 cycles, whichever is greater. Trip selection may be made with the load taps energized.

D. Submittals

Submit the following design and construction documents.

1. Manufacturer's product data and shop drawings
 - a. Switch and accessories physical arrangement and sizes.
 - b. Wiring diagrams.
 - c. Mounting, connection, size and location of conduits entrance details and instructions.
 - d. Equipment ratings and performance data, including overcurrent protection time-current curves.
 - e. Location of the nearest service shop, owned and operated by the manufacturer, which is capable of repairing components of the switch.
 - f. ISO 9001 certification.
 - g. Instruction, operating and maintenance manual.
 - h. Ground pad locations.
2. Upon completion of factory production tests, submit certified copies of test reports for each unit, identified by serial number.



E. Product Standards

Products shall conform to ISO 9001 certification

F. Manufacturers

The manufacturer of the medium pad mounted interrupter switches shall be G & W Electric Company. There is no substitute. Use a 600A pad mounted puffer gas switch with switch position indication.

G. Equipment

Materials and products provided shall be suitable for the intended use or application, and, where applicable, UL listed and labeled.

H. Accessories or Special Features

Pad mounted interrupter switches standard features:

1. SF6 gas pressure gauge and fill valve.
2. Grounding provisions for switch tank and cable entrances.
3. Stainless steel three line diagram and corrosion-resistant nameplates.
4. Phase-designation nameplates.
5. Viewing windows for switch position.
6. Permanently mounted operating handle.
7. Termination parking, one per hushing.
8. Switch operating handle(s) with padlock provision and end stops.
9. Type 1 vacuum interrupter electronics package including a selector switch for 3-phase operation and individual phase trip levels.



I. Extra Materials

One spare set of control power fuses for Vacuum Interrupter Electronic Controller.

J. Installation Guidelines

1. Install each unit on a level, smooth concrete pad of appropriate dimensions, in strict accordance with manufacturer's instructions.
2. Coordinate exact configuration and location of cable conduit entries to suit.
3. Terminate and connect phase and grounding conductors as required
4. Provide minimum of two (2) ground rods and #4/0bare copper ground loop placed 12-inches below undisturbed earth and 12-inches from pad perimeter and bonded to the switch per Code.
5. Protection: Where subject to vehicular damage, provide one 4-inch vertical steel pipe bollard filled with concrete and located at each corner of the concrete pad. Minimum height above grade shall be 60-inches; minimum depth below grade shall be 40-inches. Deliver the switch after protection is installed.
6. Tighten all electrical connectors and terminals according to manufacturer's published torque values or as specified in UL 486A and UL 486B.

K. Quality Control

1. Factory Quality Control Testing

- a. Each unit shall be fully tested at the factory in accordance with ANSI C37.57 Metal-Enclosed Interrupter Switchgear Assemblies - Conformance Testing.
 - 1) Installed SF6 gas moisture content.
 - 2) Gas tank pressure.
 - 3) Leak test.
 - 4) Mechanical operation.
 - 5) AC hi-pot test one minute phase to phase, phase to ground and across the open contacts. Check circuit resistance on ways.
- b. Submit copies of test reports, including certification that units comply with applicable standards and specifications, and are acceptable to use.

2. Field Quality Control Testing

- a. After switches installation, but prior to energizing, the contractor shall provide the services of a factory-authorized field service technician to inspect each



installation, perform factory-recommended tests, and certify each as ready to energize. Minimum field testing shall include DC megger, contact resistance, and gas leakage tests.

- b. Test and set electronic fault protection time current settings.
- c. A certified field service report for each unit shall be submitted for record.

L. Cleaning and Adjusting

After installing and cleaning, touch up scratches and mars on finish to match the original finish. Wipe all buses and terminals to remove dust with water or alcohol damped cloth.

End of Section



16361-D

Double-Ended Unit Substation

This document provides design standards only, and is not intended for use, in whole or in part, as a specification. Do not copy this information verbatim in specifications or in notes on drawings. Refer questions and comments regarding the content and use of this document to the Yale University Project Manager.

CONTENTS

- A. [Summary](#)
- B. [References](#)
- C. [System Design and Performance Requirements](#)
- D. [Submittals](#)
- E. [Product Standards](#)
- F. [Manufacturers](#)
- G. [Equipment](#)
- H. [Accessories or Special Features](#)
- I. [Extra Materials](#)
- J. [Special Requirements](#)
- K. [Installation Guidelines](#)
- L. [Field Quality Control](#)
- M. [Cleaning and Adjusting](#)
- N. [Startup and Training](#)

A. Summary

This section contains design criteria for secondary unit substation which consisting of primary selector switches with fuses, cast coil copper wound substation transformers, and secondary switchgear and main protective devices.

B. References

The following industry standards, codes, and guidelines describe how the overall system should be designed:

1. ANSI C37.121, 1989 – Secondary Unit Substations
2. ANSI C37.13 – Low-voltage Power Circuit Breakers
3. ANSI C37.17 – Trip Devices
4. ANSI C37.20 – Switchgear Assemblies
5. ANSI C39.1 – Meters
6. ANSI C62.1 – Surge Arresters
7. NEMA ST 20, 1997 and IEEE C.57.12.01 – dry-type, cast coil, 2-winding, substation transformer for indoor application



8. UL 486A, UL 486B and UL 1558
9. NETA Acceptance Test Specifications (ATS)
10. Transformer efficiency shall comply with new D.O.E. Standards
11. ANSI c57.1201

C. System Design and Performance Requirements

Equipment service conditions shall meet temperature range of 0 to 40 degree C and humidity range of 5 to 95 percent, non-condensing.

1. System shall consists two duplex load interrupter switches with two cast coil copper wounded transformers with a 480 V switchgear. The switchgear shall contain main-tie-main drawout electrical operated circuit breaker with an automatic throwover scheme.
2. Normal Primary/Incoming Section Equipment
 - a. The primary of the system shall be a two load interrupter switches to a common fuse that will allow the connection to the transformer to one of two incoming lines mounted inside dead-front metal enclosed compartment with a view window and with a close couple connection to the transformer section. Each primary switch that receives the radial feeders shall have 18 kV station class lightning/surge arresters.
 - b. Each duplex interrupter switch shall have two sets of synchronized sources incoming lines. These switches are provided for manual primary close transition throwover. Each switch section shall have a strip space heaters.
 - c. Terminals shall be compression-type for use with low smoke, zero halogen type and size 500 MCM cables.
 - d. Maximum design voltage shall be 15 kV with Basic Impulse Level 95 kV and continuous current rating of 600A.
 - e. One set of three power fuses shall be mounted in separate compartment within switch cabinet. Fuses shall be accessible through a hinged door, mechanically interlocked with interrupter switch such that entry may only be accomplished by de-energizing the switch.
 - f. Interrupter enclosure shall be rated for the environment.



- g. The interrupter switches shall have Kirk key interlock for locking out system for maintenance purpose
- h. Connections between incoming switches and transformer shall be Buss or with shielded 15 kV cable with a low smoke zero Halogen jacket.
- i. Switches shall be rear accessible.

3. Transformer Section Equipment

- a. Substation transformers shall be dry-type, cast coil, copper wound, 2-winding, air cooled with forced air Class AA/FA rating. Core and coil assembly shall be enclosed in a ventilated steel housing for indoor application.
- b. Transformer connection shall be delta-wye with 15 kV primary, basic Impulse Level 95 kV and 480 Y/277 volts secondary.
- c. The cast coil transformer shall have 180 degree C or higher insulation including epoxy with 80 degree C rise over 40 degree C.
- d. Cast coil transformer shall include 120/240 VAC cooling fan to provide additional capacity with winding temperature monitor and alarm. Transformer shall have a separate ground to the building ground bus with a # 4/0 AWG copper wire.
- e. All unit substation shall be grounded in three (3) locations (one on the transformer, one on the main interrupter switches and one on the 480 v switchgear), forming two (2) separate ground paths to the building ground bus. All ground conductors shall not be smaller than size #4/0 Awg copper wire. Insure the ground resistance at the substation is no more than 5 ohms by adding more number of ground conductors, and/or ground rods for building grounding system.
- f. Provide isolation pads to isolate core and coil assembly from casing.
- g. Provide four 2-1/2 percent full capacity taps, two above and two below rated nominal voltage.
- h. Dry type transformer sound level shall not exceed the maximum specified by ANSI C57.1201 as shown below for applicable kVA.

- 1) 301 – 500 kVA < 60 dB



- 2) 501 – 700 kVA < 62 dB
- 3) 701 – 1000 kVA < 64 dB
- 4) 1500 – 2000 kVA < 65 dB

4. Secondary Low Voltage Switchgear Section Equipment

- a. The switchgear shall be directly connected to the adjacent transformer section and include main- tie-main circuit breaker with automatic/manual secondary close transition throwover with surge protection device. Surge protection shall be mounted directly to the bus in main protection devices section in accordance with the requirement of [Section 16289 Transient Voltage Surge Suppression](#).
- b. Provide line and load terminals accessible from the front only and they are suitable for conductors termination.
- c. Main and tie circuit breakers shall be electrically operated and true draw-out mounted, RMS sensing electronic trip with LSIG function, insulated case, 100% service rated, two-step stored energy type circuit breaker.
- d. For utility plant applications substation shall be equipped with low voltage power circuit breaker for the entire substation.
- e. Bus connections shall be bolted, and accessible from front for easy maintenance.
- f. Bus or flexible bus link shall be copper and be sized in accordance with NEMA PB 2 Standard.
- g. Sections shall be aligned at front only.
- h. Provide fully equipped future space provisions with bussing and bus connections.
- i. M-T-M circuit breakers shall have a Kirk key lock to lock out system for maintenance.
- j. Substation design shall be suitable for the environment.



- k. If switchgear is separated, the use of conduit and wire shall not be used. Only bus duct is approved for this type of installation. This is for the connection of the tie breaker and if switchgear is not directly connected to transformer.
- l. Each 480 V low voltage switchgear section shall be equipped with Schneider/Square D PowerLogic ION meter system Cat # SQDP7330BWY and shall be tied into Yale I-fix communication system.

1) The ION meter system part number / spec as follows:

- a) P7330 - ION 7330 meter
- b) A0 - Integrated Display with Optical port
- c) B - Standard Current Input
- d) 0 - Standard Voltage Input
- e) B - Standard Power Supply
- f) 0 - Standard System Frequency (50-60 HZ)
- g) E0 - Standard plus Ethernet Communication
- h) A - No I/O option
- i) 0 - Password Protected, no security lock
- j) A - No Special Order Option
- k) AA027 - Yale Framework of Meter registers

2) The current transformers for Ion meters, Size and quantities are indicated on Drawing.

CT's shall be relay class 20 for the 100/5 ratio Ion Meter using ItI or GE model #143, 145, 685 or 785. CT's shall be relay class 50 for 200/5 ratio Ion Meter using ItI or GE model #143, 145, 307, 309, 389, 685 or 785.



- 3) CTs shall be relay class 100 for the 400/5 ratio Ion Meter using ItI or GE model # 143, 145, 307, 309, 389, 685 or 785.
The 600/5 and 800/5 ratio CTs shall be relay class 200 using ItI or GE model # 143, 145, 307, 309, 389, 685 or 785.
The 1000/5 and 1200/5 ratio CTs shall be relay class 200 and 400 respectively using ItI or GE model # 143, 145, 307, 309, 389, 685 or 785 . The 1600/5 ratio CTs shall be relay class 400 using ItI or GE model # 143, 145, 307, 309, 389, 685 or 785 . The 2000/5 ratio CTs shall be relay class 800 using ItI or GE model # 307 and 309.
- 4) All wiring for CTs shall be #10 AWG stranded SIS type wire.
- 5) All Ion Meter CT wiring shall be to shorting blocks before being wired to the ABB test block. All wiring from the test block to the meter shall be tagged per the vendor supplied interconnection drawings. Test block shall be ABB style FT-1 and Cat # 129A514G01 with clear covers.

D. Submittals

1. Designer Submittals

- a. The protective devices short circuit and over current protection coordination study shall accompany unit substation submittals and the study shall certify all its components and the substation meets or exceeds the electrical system requirement. Study shall include all 480 v feeder breakers in switchgear.

2. Construction Documents

Submit the following construction documents:

Product Data

- a. Submit manufacturer's catalog data for secondary unit substations and components including construction details and component and device specifications.

Shop Drawings Information

Submit project-specific shop drawings including the following:



- a. Front and side views of enclosures with overall dimension shown.
- b. Conduit entrance locations and requirements
- c. Nameplate legends
- d. Size and number of bus bars per phase, neutral, and ground.
- e. Primary selector device, transformer, secondary main-tie-main devices, instrument and metering details.
- f. Instruction for handling and installation of the unit substation.
- g. Electrical characteristics including voltage, frame size and trip ratings, withstand ratings, and time-current curves of equipment and components.

Certified Test Reports

- a. Provide factory transformer certified loss evaluation report.
- b. Provide field test reports and certify that the system is in compliance with test parameters.

Field Measurements

- a. Make necessary field measurements and provide equipment layout diagram to confirm that equipment shall fit in allocated space in full compliance with minimum required clearances specified in National Electrical Code.

Operations and Maintenance Data

- a. Provide overcurrent protective device adjusting and testing instructions.
- b. O & M Manuals shall include bus tightening intervals and procedures, and overcurrent protective device maintenance procedures.

E. Product Standards

Products shall conform to the following standards:



1. ANSI C57.1201
2. NEMA PB-2, 1995
3. Latest Codes and Standards
4. Latest D.O.E. Efficiency on Transformers

F. Manufacturers

Subject to compliance with the design requirements, provide unit substation by one of the following manufacturers:

1. Square D
2. General Electric
3. Cutler-Hammer/Eaton
4. ABB



G. Equipment

1. Power fuses shall be provided by Bussmann E-rated, GE Type EJ, or Shawmut Type CL-14.

H. Accessories or Special Features

Unit substation transformer standard features:

1. Stainless steel diagrammatic nameplate mounted on transformer enclosure.
2. Provide provisions for lifting and jacking unit into place.
3. Base suitable for rolling and skidding parallel to centerline.
4. Equip 120 VAC space heaters with thermostat.
5. Include 3 kVA control transformer with a fused primary, 480 VAC to 120/240 VAC, single phase with a throw over capability.
6. Transformer high temperature monitor with local audible and visual alarm and contacts for remote alarm.
7. Each substation shall have a trolley lifting mechanism for the removal of circuit breakers.

Automatic throwover standard features:

1. Main-Tie-Main shall have automatic transfer to alternate source and automatic re-transfer to normal source with close transition.
2. Two sources shall be electrically interlocked.
3. Provide manual circuit breaker operation inhibited button.
4. No time delay on transfer and only re-transfer shall have 10 second delay with close transition.
5. Source stabilization before retransfer shall be set at 10 seconds.
6. Undervoltage sensing (Device 27) on both sources shall be set at 10% differential strap adjustable with local LED indication.
7. Phase loss (Device 47) set at 68% of nominal voltage with local LED indication.
8. Phase sequence (reverse phase) sensing (Device 47) on both sources set at 2 cycles with local LED indication.



9. Phase imbalance (Device 47) set at 2% strap adjustable with local LED indication.
10. Provide Auto/Manual switch with removal key interlock and light indication. Note: Manual mode operation shall allow operator to parallel both synchronized sources for routine maintenance.
11. Control power shall have an automatic transfer switch between two incoming sources plus a TRIPP Model 4 uninterruptible power supply (UPS) with UPS bypass relay.
12. For AUTO throwover system the PLC shall have TRIPP Model 4 UPS power supply system for a primary control power. PLC shall be Allen Bradley, no substitutes.
13. The drawout breakers shall have a full automatic mode in the test position.
14. Provide a test switch for simulating loss of voltage of either source.
15. Provide circuit breaker electrical trip lockout with amber LED light indication.
16. Provide sync check relay (Device 25) if it is required by the manufacturer.
17. Refer to [Attachment 1 – ATO Operation](#) in the end for detail operation instructions.

I. Extra Materials

1. One spare set of three 15 kV power fuses shall be required.

J. Special Requirements

1. Frame and cover printed operating instructions for unit substations, including key interlocking, control sequences, and emergency procedures, with clear acrylic plastic. Insert instructions in a fabricated frame of finished wood or metal and mount on front of unit substation.

K. Installation Guidelines

1. Install unit substations on 4 inches high concrete housekeeping pad with 2 inches wider and longer than substation widest and longest section.
2. Tack weld or bolt substation support footings to channel-iron sills embedded in the concrete pad. Install sills level and grout flush with pad surface.



3. Ground all metal parts of the unit substation to main electrical ground bus at two locations.
4. Unit substation shall be accessible front and rear.
5. Tighten all electrical connectors and terminals according to manufacturer's published torque values or as specified in UL 486A and UL 486B.
6. Remove temporary lifting eyes, channels, brackets, and temporary blocking of moving parts from substation units and components.

L. Field Quality Control

1. Field Quality Control Testing
 - a. Engage a factory-authorized service representative to supervise the field assembly of components, connections, preliminary testing, controls and safeties adjustment. Replace damaged and malfunctioning components and provide service result report in writing.
 - b. Owner will engage a qualified independent testing agency or an approved manufacturer's service organization to perform specific acceptance testing.
 - c. Perform visual and mechanical inspection and electrical tests stated in NETA ATS or submit equivalent manufacturer's startup procedures.
 - d. Perform load interrupter switchgear testing in accordance with NETA ATS, Section 7.5 Standards or approved equivalent manufacturer's startup procedures.
 - e. Perform air transformer testing in accordance with NETA ATS, Section 7.2 Standards or approved equivalent manufacturer's startup procedures.
 - f. Perform low voltage switchgear testing in accordance with NETA ATS, Section 7.2 Standards or approved equivalent manufacturer's startup procedures.
 - g. After the electrical testing is complete and the substation has been energized, demonstrate product and control capability in compliance with requirements.
 - h. Remove and replace malfunctioning components with new units and retest.



- i. Provide certified reports that the system is in compliance with test parameters.
 - j. All equipment shall be vacuumed and cleaned prior to energization.
2. Commissioning
- a. If this portion of the project includes commissioning, verify that insertions in the project specifications have been made that refer to the commissioning procedures in the commissioning specification section. Verify that the systems and equipment identified in this section of the standards, and listed in the project specifications, do not conflict with commissioning procedures for testing and training.

3. Monitoring

After Substantial Completion, when requested by owner, but no more than 6 months after Final Acceptance, commissioning agent will perform the following voltage monitoring and adjusting:

- a. During a period of normal load cycles as evaluated by owner, perform 7 days of 3-phase voltage recording at the low voltage switchgear outgoing section of the unit substation. Use voltmeters with calibration traceable to National Institute of Standards and Technology standards and with a chart speed of no less than 1 inch (25 mm) per hour. Voltage unbalance greater than 1 percent between phases or deviation of any phase voltage from the nominal value by more than plus or minus 5 percent during the test period is unacceptable.
- b. If test results are unacceptable, take the following corrective actions, as appropriate:
 - Adjust transformer taps
 - Rebalance loads
 - Send a written request to the electrical utility for voltage adjustment
- c. Repeat monitoring, after corrective action has been performed, until satisfactory results are obtained.
- d. Provide a written report describing voltage monitoring performance and corrective action taken.



M. Cleaning and Adjusting

1. Clean and vacuum interior of separate enclosures to remove construction debris, dirt, and shipping material. Wipe all buses and terminals to remove dust with water or alcohol damped cloth.

N. Startup and Training

Engage a factory-authorized service representative to train owner's maintenance personnel as specified below:

1. Train owner's maintenance personnel on procedures and schedules related to startup and shutdown, troubleshooting, servicing, and preventive maintenance.
2. Review data in the maintenance manuals. Refer to Division 1, [Section 01730 Project Execution and Closeout](#).
3. Review data in the maintenance manuals. Refer to Division 1, [Section 01782 Operation and Maintenance Data](#).
4. Schedule training with owner, through Architect, with at least 7 days' advance notice.



Attachment 1 – ATO Operation

When the “Control Power” light is on, the PLC is energized and it is functioning properly.

ATO OPERATING INSTRUCTIONS THREE-BREAKER AUTOMATIC THROWOVER SUMMARY OF NORMAL OPERATION

1. The selector switch is in AUTO mode, Source #1, (Main breaker), Source # 2 (Main breaker) and the Tie breaker are open. Source # 1 and Source # 2 are both energized only when their respective utility is available. When each source bus is energized the corresponding source main breaker will close after a 5 second time delay. However if both sources fail to energize no action will be taken by the PLC. Once one of the sources becomes available the dead bus side shall be transferred to the available energized bus by closing the tie breaker. Once the failed source is restored the PLC will monitor the source for 10 seconds for assured stability before issuing a retransfer via closed transition.
2. If both main breakers are closed and the tie breaker is open and if both sources fail, and then return simultaneously, no action is taken. The PLC will issue a transfer to the normal main if it is found to be open and its source is available.
3. No transfers will be allowed if one of the source mains trips due to an over-current or ground - fault situation. All such trips must be reset before normal operations can commence.
4. Once a transfer has occurred, if the tie breaker trips, it shall remain tripped / open until a manual reset is performed.
5. All interlocking of breakers are hardwired in the breaker close circuitry and programmed within the PLC to prevent the paralleling of unsynchronized sources. The PLC will perform the automatic commands within the boundaries set forth in the interlocking.
6. Manual operations are performed by placing the selector switch in MANUAL mode and via the use of the breaker control switches. The PLC will not be able to perform any automatic operations while the selector switch is in MANUAL mode. The auto mode light (blue) will turn off to alert the operator that the ATO is in MANUAL mode and no longer under PLC control.



7. If a breaker is commanded closed and does not close within 2 seconds, the breaker is then “locked out” via the PLC. The “Control Power” light will begin to blink to indicate a problem. To acknowledge and reset this alarm, switch the TRANSFER MODE SELECTOR to MANUAL. Switch back to AUTO for PLC controls operation. The system is equipped with a TEST switch to simulate loss of sources to test the ATO operation. The TEST switch can be placed in M1 FAIL mode to simulate a loss of Source # 1 or in M2 FAIL mode to simulate a loss of Source # 2. The simulation is all within the PLC program and thus no true power loss will occur. The inhibited source indication light will strobe and the system will operate as if a loss of power had occurred. True monitoring of the sources will remain uninhibited such that if one of the sources truly does fail while using the TEST switch the PLC will cancel the testing operation and begin addressing the true loss of power.

I. AUTOMATIC SEQUENCE OF OPERATION (OPEN TRANSITION):

* Selector Switch is in AUTO mode.

A) LOSS OF POWER TO LOAD BUS # 1

When power to LOAD BUS # 1 drops below the threshold settings of the load bus under-voltage relay, the PLC will open the source 1 breaker, 52-1 and initiate a transfer to Source # 2 IMMEDIATELY by closing the tie breaker 52-T. All loads will be serviced by Source # 2 until Source # 1 is restored and stable for 10 consecutive seconds.

B). LOSS OF POWER TO LOAD BUS # 2

When power to LOAD BUS # 2 drops below the threshold settings of the load bus under-voltage relay, the PLC will open the source 2 breaker, 52-2 and initiate a transfer to Source # 1 IMMEDIATELY by closing the tie breaker 52-T. All loads will be serviced by Source # 1 until Source # 2 is restored and stable for 10 consecutive seconds.



II. AUTOMATIC RETRANSFER BETWEEN SOURCES (CLOSED TRANSITION):

The ATO is still operating in AUTO mode and no faults have been detected. Upon return of the failed source, the PLC will monitor that source for 10 seconds to assure stability before retransfer. After 10 seconds and upon synchronization between the two sources for 2 seconds, as indicated by the synchronization light, the PLC will keep the tie breaker closed and also close the restored source main breaker to complete the retransfer of the load to its normal source. The PLC will open the tie breaker after a set time delay 2 seconds adjustable between 0.5-10 seconds once it has received confirmation that the normal source main has closed. If any main breaker trips due to an over-current or ground fault situation, before or after any transfers, then that main will not be able to close again until a manual reset is performed to clear all faults.

If both sources fall simultaneously such that no source is available then the PLC will keep both Source main breakers in their last state until one of the sources become available again. Automatic transfers will commence as previously described only when sources are available and no faults are present.

III. AUTOMATIC RETRANSFER BETWEEN SOURCES (OPEN TRANSITION):

The ATO is still operating in AUTO mode and no faults have been detected. Upon return of the failed source, the PLC will monitor that source for 10 seconds to assure stability before retransfer. After 10 seconds, the PLC will open the tie breaker and close the restored source main breaker to complete the retransfer of the load to its normal source. If any main breaker trips due to an over-current or ground fault situation, before or after any transfers, then that main will not be able to close again until a manual reset is performed to clear all faults. If both sources fall simultaneously such that no source is available then the PLC will keep both Source main breakers in their last state until one of the sources become available again. Automatic transfers will commence as previously described only when sources are available and no faults are present.

IV. MANUAL OPERATION VIA BREAKER CONTROL SWITCHING

Manual operations via the breaker control switches disable PLC automatic transfer operations. The transfer of sources is via open or closed transition and is enabled when switching from AUTO mode to MANUAL mode.

To manually transfer the load from its normal source to the alternate source when the normal Source is still available, do the following:



A) MANUAL TRANSFER (OPEN TRANSITION)

1. Turn the Selector switch to Manual mode. The auto mode light (blue) should turn off.
2. Verify that the alternate source is still available by noting whether the availability light is still on for that source.
3. After verification, open the normal source main breaker and close the tie breaker by using the tie breaker control switch to initiate a transfer of load service to the alternate source main breaker.

B) MANUAL TRANSFER (CLOSED TRANSITION)

1. Turn the selector switch to MANUAL mode. The auto mode light (blue) should turn off.
2. Verify that the synchronization of sources light (green) is on. **(NOTE):** The signal for this light is provided by the synchronization check relay (25). This some relay supplies the signal to enable Paralleling in the interlocking scheme for the mains and tie breakers.
3. After verification, close the tie breaker while the normal source main breaker and the alternate source main breaker is closed by using the tie breaker control switch to initiate a closed transition transfer of load service. **(NOTE):** Prolonged paralleling of sources can create a hazardous condition to the equipment and to the operator. Therefore, on adjustable 0.5-10 second external timer circuit (Factory set for 10 sec) is incorporated to limit the time of paralleling of the synchronized sources. If paralleling of sources exceeds the set time limit the tie breaker will open to remove the paralleling of sources.
4. After completing a manual transfer, turn the selector switch back to AUTO if automatic operation (PLC control) is desired. If the selector switch is left in MANUAL the auto mode light will remain off as a reminder that the switchboard is operating in MANUAL mode.

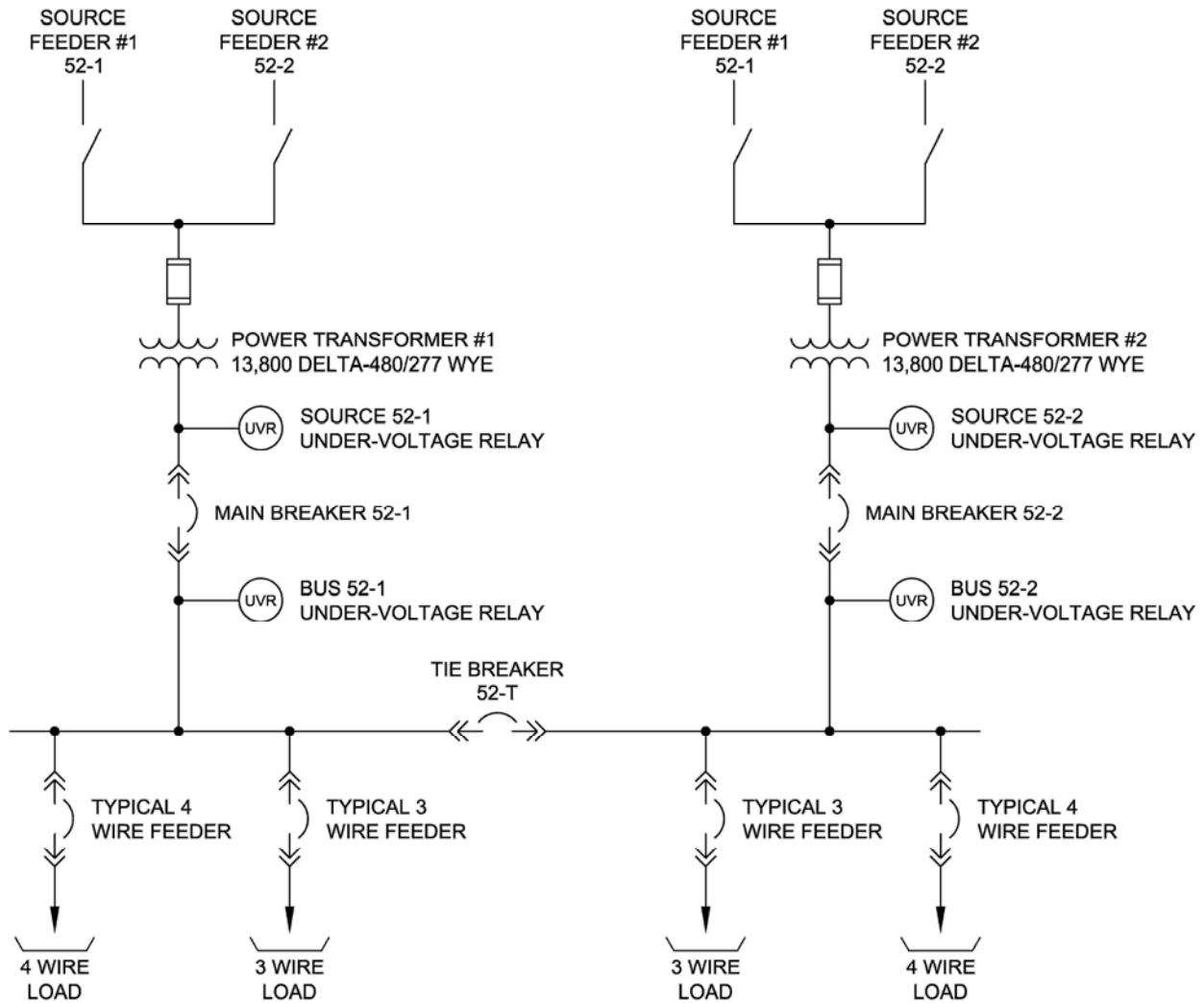

FIGURE 1-1

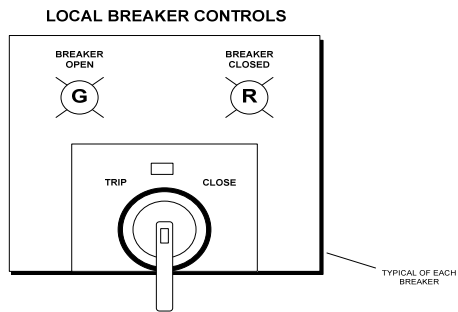
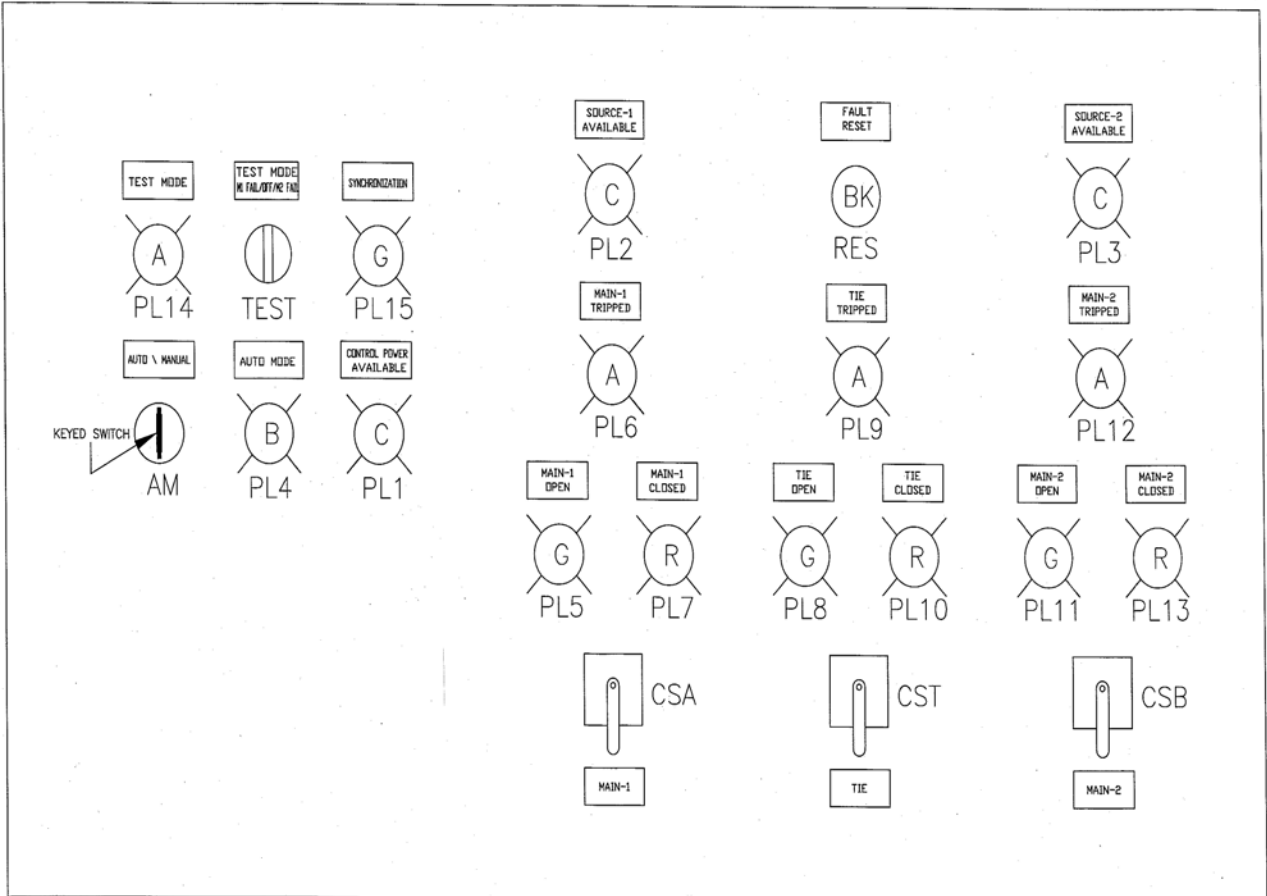
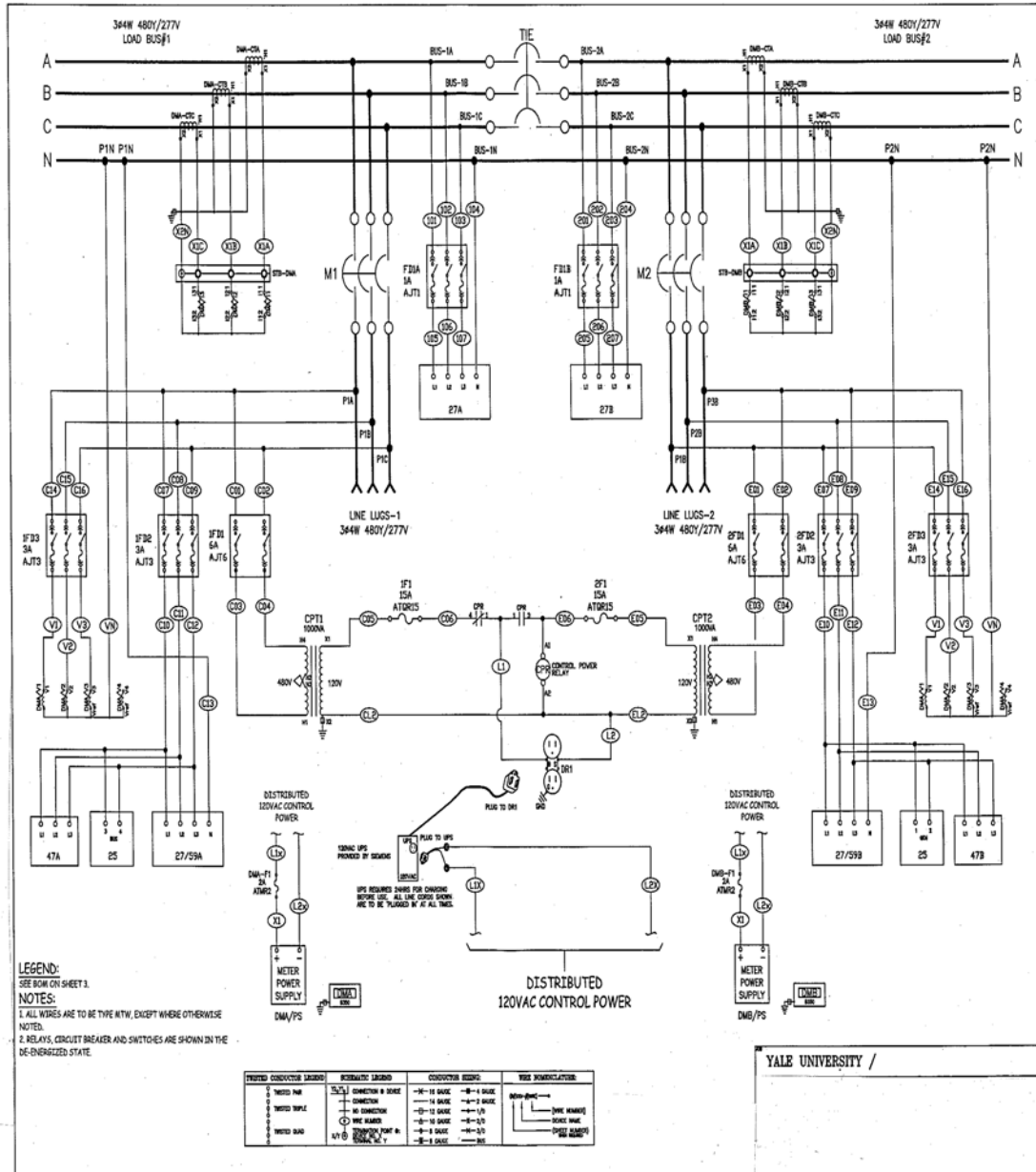

FIGURE 1-2



ATO CONTROLS DETAIL 'A'

4" X 3" ENGINEER UNIFORM



ATO Control Schematic and Three Line Diagram



End of Section



16361- E

Pad Mounted Distribution Transformers

This document provides design standards only, and is not intended for use, in whole or in part, as a specification. Do not copy this information verbatim in specifications or in notes on drawings. Refer questions and comments regarding the content and use of this document to the Yale University Project Manager.

CONTENTS

- A. [Summary](#)
- B. [References](#)
- C. [System Design and Performance Requirements](#)
- D. [Submittals](#)
- E. [Product Standards](#)
- F. [Manufacturers](#)
- G. [Equipment](#)
- H. [Accessories or Special Features](#)
- I. [Extra Materials](#)
- J. [Installation Guidelines](#)
- K. [Quality Control](#)
- L. [Cleaning and Adjusting](#)

A. Summary

This section contains design criteria for pad mounted distribution transformers and protective devices.

B. References

The following industry standards, codes, and guidelines describe how the overall system should be designed:

1. C57.12.00 -IEEE Standard General Requirements for Liquid-Immersed Distribution, Power and Regulating Transformers.
2. C57.12.10 - Safety Requirements 230 kV and Below 833/958 Through 8333/10417 kVA, Single- Phase, and 750/862 through 6000/8000/10000 kVA, Three-Phase without Load Tap changing; and 3750/4687 through 6000/8000/10000 kVA with Load Tap changing.
3. C57.12.26 -Pad-Mounted, Compartmental-Type, Self-Cooled, Three-Phase Distribution Transformers For Use with Separable Insulated High-Voltage Connectors, High Voltage, 34500GrdY119920 Volts and Below; 2500 kVA and Smaller.
4. C57.12.28 - Pad-Mounted Equipment -Enclosure Integrity.
5. C57.12.90 -IEEE Standard Test Code for Liquid-Immersed Distribution, Power, and Regulating Transformers and IEEE Guide for Short-Circuit Testing of Distribution and Power Transformers.
6. C57.92 -Guide for Loading Mineral-Oil-Immersed Power Transformers Up to and including 100 MVA with 65°C or 55°C Average Winding Rise.



C. System Design and Performance Requirements

Equipment service conditions shall meet temperature range of - 20° to 100°F and humidity range of 5 to 100 percent, non-condensing.

1. Transformers shall be three phase, copper wound, liquid immersed, dead front secondary distribution type, tamperproof and weatherproof, and suitable for mounting on a concrete pad. There shall be no exposed screws, bolts or other externally removable fastening devices. There shall be no openings through which foreign objects, such as sticks, rods, or wires might be inserted to contact live parts.
2. Transformers shall have efficient design per new D.O.E-1 Standard.
3. Transformers shall be rated 13,800V Delta primary, 480/277V Wye secondary with basic impulse insulation level (BIL) 95 kV.
4. Impedance: The percent impedance, as measured on the rated voltage connection, shall be as indicated in the table below. The tolerance on the impedance shall be +I- 7.5% of nominal value for impedance values greater than 2.5%. The tolerance on the impedance shall be +I- 10.0% for impedance values less than or equal to 2.5%.

Percent Impedance Voltage

kVA Rating	Impedance
75	1.00 – 5.00
112.5 - 300	1.20 – 6.00
500	1.50 – 7.00
750 -3750	5.75

5. The average winding temperature rise above 40°C ambient temperature, when tested at the transformer rating, shall not exceed 55 degree C with fan cool unit 65 degree C.
6. Dielectric Coolant
 - a. The dielectric coolant can be bio-based biodegradable electrical insulating and cooling liquid. The base fluid shall be 100% derived from edible seed oils. The performance enhancing additives shall be food grade. The fluid shall be certified to comply with the US EPA Environmental Technology Verification (ETV) requirements, and tested for compatibility with



transformer components. The fluid shall be Factory Mutual Approved and UL Classified, Envirotemp **FR3** fluid.

- b. The dielectric coolant can be silicone oil.
7. Average sound level per NEMA TRI shall not exceed the following values. The measurement procedure shall be as specified in ANSI C57.12.90. also latest D.O.E. standards.

KVA	Decibels
75	51
112.5 -300	55
500	56
750 -1000	58
1500	60
2000	61
2500	62

8. Transformer Construction

- a. High Voltage Bushings and Terminals: 15 kV, 200A bushing wells with bushing well inserts installed. The bushings shall be externally removable. Include parking stands, one for each high voltage bushing well. Radial Configuration feed shall be per Figure 5 of ANSI C57.12.26 and heights per Figure 7 of ANSI CS7.12.26.
- b. High Voltage Overvoltage Protection shall be deadfront, elbow-type, metal oxide varistor (MOV) units, and station class surge arresters (18 kV or 5 kV).
- c. Provide high-voltage over current protection with the transformer equal to an externally removable load break expulsion Bay-O-Net fuse assembly with a flapper valve to minimize oil spillage. The bayonet fuses shall be in series with ELSP under-oil partial-range current-limiting back-up fuses with an interrupting rating of 50,000 amperes. The expulsion fuses shall have a maximum rating of 300% primary full load current to comply with NEC Article 450-3(a), and shall be replaceable through the tank handhole. Provide one complete set of spare fuses inside the high voltage compartment.



- d. Secondary Voltage Bushings and Terminals: The transformer shall be provided with tin-plated spade-type bushings. The spacing of the connection holes shall be 1.75" on center, per ANSI C57.12.26 figure 9. The quantity of connection holes shall be 16 holes; 2 holes per phase conductor termination. Bushing supports shall be provided for units requiring 10 or more connection holes. Bushing supports shall be attached to the cabinet sidewalls or roof; tank-mounted support mountings are not acceptable.
 - 1) Secondary Bushing Configuration: The transformer shall be provided with bushings in a staggered arrangement in accordance with Figure 8a of ANSI C57.12.26. The bushing heights shall be in accordance with Figure 7 of ANSI C57.12.26.
- e. Tap Changer Full-Capacity Voltage Taps shall have four 2.5-percent taps; two above and two below rated high voltage; externally, hook stick operated for de-energized operation. Include: visible position indicator and provisions for pad locking in each tap position.
- f. Tank Design shall include the following features:
 - 1) Tank, cooling equipment and compartments shall be subject to operating pressures and full vacuum without permanent deformation.
 - 2) Sufficient expansion volume to allow operation under specified load conditions. One or more bolted-on handholes in the tank cover for access to bushing connections.
 - 3) Lifting lugs for each tank corner.
 - 4) Jacking pods or bosses.
 - 5) Tank base to allow skidding or rolling in any direction.
 - 6) Stainless steel cabinet hinges and mounting studs.
 - 7) Pressure relief valve with flow at 15 psig of 35 SCFM, minimum.
- g. Primary & Secondary Compartments:
 - 1) Depth-Comply with Figure 7 of C57.12.26, unless additional depth is required to meet BIL requirements.
 - 2) Locking -Recessed, padlockable, captive, pentahead bolt per ANSI C57.12.28, bolt is accessible only after removal of padlock.



3) Low voltage compartment shall be on right.

h. Grounding:

1) Ground non-energized metallic components.

2) Minimum of two stainless steel ground pads, welded to the base or to the tank wall near the base on diagonal comers. Transformer shall be grounded at two locations to grounding grid.

i. Finish: Tank, cooling components and compartments shall meet requirements of ANSI C57.12.28 including:

1) Salt spray test.

2) Crosshatch adhesion test.

3) Humidity test.

4) Impact test.

5) Oil resistance test.

6) Ultraviolet accelerated weathering test.

7) Abrasion resistance -Taber abraser.

8) Color -Munsel7GY3.2911.5 green.

j. Nameplate:

1) Stainless steel, laser engraved including: name of manufacturer, date of manufacture, place of manufacture and tested.

2) Include connection and rating information per ANSI C57.12.00 nameplate Type C, plus approximate weight of parts to be lifted for un-tanking, type and quantity of coolant liquid.

3) Marking shall include a NEMA Standard Figure 3 Outside Warning Label on the exterior side of the high voltage compartment door and a NEMA Standard Figure 4 Inside Danger Label on the inside low voltage compartment door.

4) High voltage warning signs, danger signs, Factory Mutual approval, and Underwriters Laboratory approval.



D. Submittals

Submit the following design and construction documents.

1. Manufacturer's product data and shop drawings:
 - a. Transformers and accessories physical arrangement and sizes.
 - b. Wiring diagrams.
 - c. Size and location of conduit entrances for connections.
 - d. Ground pad locations.
 - e. Mounting, anchoring and connection details and instructions.
 - f. Weight of core and coil, transformer tank and fittings, weight and gallons of fluid, and total shipping weight.
 - g. Equipment ratings and performance data, including overcurrent protection time-current curves.
 - h. Instruction, operating and maintenance manual.
 - i. Location of the nearest service shop, owned and operated by the manufacturer, which is capable of repairing components of the transformer.
2. Upon completion of factory production tests, submit certified copies of test reports for each unit, identified by serial number.

E. Product Standards

Products shall conform to the following standards:

1. NEMA TP-1, 1993 (R2000)
2. NEMA TR-1, 1993 (R2000)
3. EPA Environmental Technology Verification (ETV)

F. Manufacturers

Subject to compliance with the design requirements, provide unit pad mounted distribution transformers by one of the following manufacturers:

1. Cooper Power Systems
2. General Electric



3. ABB

G. Equipment

1. Materials and products provided shall be suitable for and UL listed and labeled. Transformers shall be Factory Mutual (FM) approved code listed and labeled, designed in accordance with the requirements of ANSI C57.12.00 and labeled by Factory Mutual Research Corporation as meeting the requirements of FMRS Approval Standard Class 3990.

H. Accessories or Special Features

Pad mounted distribution transformer standard features:

1. Drain Valve: 1 inch (25 mm), with sampling device and filler plug.
2. Dial-type thermometer.
3. Liquid-level indicator.
4. Pressure-vacuum gage.
5. Pressure-Relief Device: Self-sealing with an indicator.

I. Extra Materials

1. One spare set of three 15 kV or 5 kV power fuses shall be required.

J. Installation Guidelines

1. Install unit substations on 4 inches high concrete housekeeping pad with 2 inches wider and longer than substation widest and longest section.
2. Coordinate exact configuration and location of primary and secondary conduit entries to suit
3. Provide minimum of two (2) ground rods and #4/0 bare copper ground loop placed 30-inches below undisturbed earth and 12-inches from pad perimeter and bonded to the transformer per Code; minimum two locations.
4. Protection: Where subject to vehicular damage, provide one 4-inch vertical steel pipe bollard filled with concrete and located at each corner of the concrete pad. Minimum height above grade shall be 60-inches; minimum depth below grade shall be 40-inches. Deliver the transformer after protection is installed.



5. Tighten all electrical connectors and terminals according to manufacturer's published torque values or as specified in UL 486A and UL 486B.
6. Remove temporary lifting eyes, channels, brackets, and temporary blocking of moving parts from transformer and components.

K. Quality Control

1. Factory Quality Control Testing

- a. Each unit shall be fully tested at the factory in accordance with ANSI Test Code C57.12.90.
- b. In addition to the ANSI tests, each unit shall be tested for the following:
 - 1) No-load (85°C) losses at rated current.
 - 2) Total (85°C) losses at rated current.
 - 3) Percent impedance (85°C) at rated current.
 - 4) Excitation current (100% voltage).
 - 5) Winding resistance measurement.
 - 6) Ratio tests using all tap settings.
 - 7) Polarity and phase relation.
 - 8) Induced potential.
 - 9) Full wave and reduced wave impulse
 - 10) Oil test..
- c. Submit copies of test reports, including certification that units comply with applicable standards and specifications, and are acceptable to use.

2. Field Quality Control Testing

- a. After transformer installation, but prior to energizing, the contractor shall provide the services of a factory-authorized field service technician to inspect each installation, perform factory-recommended tests, and certify each as ready to energize. Minimum field testing shall include oil sample test, DC megger and turns ratio tests.



- b. A certified field service report for each unit shall be submitted for record.

L. Cleaning and Adjusting

1. After installing and cleaning, touch up scratches and mars on finish to match original finish. Wipe all buses and terminals to remove dust with water or alcohol damped cloth.
2. Adjust transformer taps to provide optimum voltage conditions at utilization equipment throughout normal operating cycle of facility. Record primary and secondary voltages and tap settings and submit with test results.
3. Occupancy Adjustment: When requested within 12 months of date of Substantial Completion, provide an-site assistance in readjusting transformer tap settings to suit actual occupied conditions. Provide up to 2 visits to Project Site for this purpose without additional cost.
4. Voltage Recordings: Contractor performed. Provide up to 48 hours of recording on the low-voltage system of each medium-voltage transformer.
5. Point of Measurement: Make voltage recordings at load outlets selected by Owner.

End of Section



16361-U

Unit Substation

This document provides design standards only, and is not intended for use, in whole or in part, as a specification. Do not copy this information verbatim in specifications or in notes on drawings. Refer questions and comments regarding the content and use of this document to the Yale University Project Manager.

CONTENTS

- A. [Summary](#)
- B. [References](#)
- C. [System Design and Performance Requirements](#)
- D. [Submittals](#)
- E. [Product Standards](#)
- F. [Manufacturers](#)
- G. [Equipment](#)
- H. [Accessories or Special Features](#)
- I. [Extra Materials](#)
- J. [Special Requirements](#)
- K. [Installation Guidelines](#)
- L. [Field Quality Control](#)
- M. [Cleaning and Adjusting](#)
- N. [Startup and Training](#)

A. Summary

This section contains design criteria for secondary unit substation which consisting of primary selector switches with fuses, cast coil copper wound substation transformers, and secondary switchgear and main protective devices.

B. References

The following industry standards, codes, and guidelines describe how the overall system should be designed:



1. ANSI C37.121, 1989 – Secondary Unit Substations
2. ANSI C37.13 – Low-voltage power circuit breakers
3. ANSI C37.17 – Trip devices
4. ANSI C37.20 – Switchgear assemblies
5. ANSI C39.1 – Meters
6. ANSI C62.1 – Surge Arresters
7. NEMA ST 20, 1997 and IEEE C.57.12.01 – dry-type, cast coil, 2-winding, substation transformer for indoor application.
8. UL 486A, UL 486B and UL 1558
9. NETA Acceptance Test Specifications (ATS)

C. System Design and Performance Requirements

Equipment service conditions shall meet temperature range of 0 to 40 degree C and humidity range of 5 to 95 percent, non-condensing.

1. The system shall consist of one duplex load interrupter switches with a cast coil copper wounded transformer with a 480 V switchgear. The switchgear shall contain main drawout electrical operated circuit breaker.
2. Alternate or Normal Single Ended Primary/Incoming Section Equipment
 - a. The primary of the system shall be a two load interrupter switches to a common fuse that will allow the connection to the transformer to one of two incoming lines mounted inside dead-front metal enclosed compartment with a view window and with a close couple connection to the transformer section. Each of the primary switch that receives the radial feeders shall have 18 Kv or 5 Kv station class lightning / surge arresters.
 - b. Each duplex interrupter switch shall have two sets of synchronized sources incoming lines. These switches are provided for manual primary close transition throwover. Each switch section shall have a strip space heaters.
 - c. Terminals shall be compression-type for use with low smoke, zero halogen type and size 500 MCM cables.



- d. Maximum design voltage shall be 5 Kv with Basic Impulse Level 60 kV and continuous current rating of 600A for 4160 v system.
 - e. Maximum design voltage shall be 15 Kv with basic impulse level 95 Kv and continuous current rating of 600A for 13.8 Kv system.
 - f. One set of three power fuses shall be mounted in separate compartment within switch cabinet. Fuses shall be accessible through a hinged door, mechanically interlocked with interrupter switch such that entry may only be accomplished by de-energizing the switch.
 - g. Interrupter enclosure shall be rated for the environment.
 - h. The interrupter switches shall have Kirk key interlock for locking out system for maintenance purpose.
 - i. Switches shall be rear accessible.
 - j. Connections between incoming switches and transformer shall be made with Buss or with shielded 15Kv cable with a low smoke zero Halogen jacket.
3. Transformer Section Equipment
- a. Substation transformer shall be dry-type, cast coil, copper wound, 2-winding, air cooled with forced air Class AA/FA rating. Core and coil assembly shall be enclosed in a ventilated steel housing for indoor application.
 - b. Transformer connection shall be delta- wye with 5 kV primary, basic Impulse Level 60 kV and 480 Y/277 volts secondary for 4160 V system.
 - c. Transformer connection shall be delta-Wye with 15 Kv primary, basic impulse level 95 Kv and 480 Y/277 volts secondary for 13.8 Kv system.
 - d. The cast coil transformer shall have 185 degree C insulation with 80 degree C rise over 40 degree C.
 - e. Cast coil transformer shall include 120/240 VAC cooling fan to provide 33% additional capacity with winding temperature monitor and alarm. Transformer shall have a separate ground to building ground bus with # 4/0 Awg copper wire.



- f. The unit substation shall be grounded in three (3) locations (one on the transformer, one on the main interrupter switches and one on the 480 V switchgear), forming three (3) separate ground paths to the building ground bus. All ground conductors shall not be smaller than size #4/0 Awg copper wire. Insure the ground resistance at the substation is no more than 5 ohms by adding more number of ground conductors, and/or ground rods for building grounding system.
 - g. Provide isolation pads to isolate core and coil assembly from casing.
 - h. Provide four 2-1/2 percent full capacity taps, two above and two below rated nominal voltage.
 - i. Dry type transformer sound level shall not exceed the maximum specified by NEMA TR-1 as shown below and latest D.O.E. Standards.
 - 1. 301 – 500 kVA < 60 dB
 - 2. 501 – 700 kVA < 62 dB
 - 3. 701 – 1000 kVA < 64 dB
 - 4. 1500 – 2000 kVA < 65 dB
4. Secondary Low Voltage Switchgear Section Equipment
- a. The switchgear shall be directly connected to the adjacent transformer section and include main circuit breaker with surge protection device. Surge protection shall be mounted directly to the bus in main protection devices section in accordance with the requirement of [Section 16289 Transient Voltage Surge Suppression](#).
 - b. Provide line and load terminals accessible from the front only and they are suitable for conductors termination.
 - c. Main circuit breaker shall be electrically operated and true draw-out mounted, RMS sensing electronic trip with LSIG functions, insulated case, two-step stored energy type circuit breaker.
 - d. Bus connections shall be bolted, and accessible from front for easy maintenance.
 - e. Bus or flexible bus link shall be copper and be sized in accordance with NEMA PB 2 Standard.



- f. Sections shall be aligned at front only.
- g. Provide fully equipped future space provisions with bussing and bus connections.
- h. Substation design shall be suitable for the environment.
- i. Unit substation shall be equipped with under voltage relays per Figure 1-1.
- j. If switchgear is separated from transformer, the use of conduit and wire shall not be used. Only bus duct shall be acceptable connections.
- k. Each 480 V low voltage switchgear section shall be equipped with Schneider/Square D PowerLogic ION meter system Cat # SQDP7330BWY and shall be tied into Yale I-fix communication system.
 1. The ION meter system Part #/Spec as followed:
 - a. P7330 - ION 7330 meter
 - b. A0 - Integrated Display with Optical port
 - c. B - Standard Current Input
 - d. 0 - Standard Voltage Input
 - e. B - Standard Power Supply
 - f. 0 - Standard System Frequency (50-60 HZ)
 - g. E0 - Standard plus Ethernet Communication
 - h. A - No I/O option
 - i. 0 - Password Protected, no security lock
 - j. A - No Special Order Option
 - k. AA027 - Yale Framework of Meter registers
 2. The current transformers for Ion meters, Size and quantities are indicated on Drawing.

CT's shall be relay class 20 for the 100/5 ratio Ion Meter using ItI or GE model #143, 145, 685 or 785. CT's shall be relay class 50 for the 200/5 ratio Ion Meter using ItI or GE model #143, 145, 307, 309, 389, 685 or 785.



3. CTs shall be relay class 100 for the 400/5 ratio Ion Meter using ItI or GE model # 143, 145, 307, 309, 389, 685 or 785.
The 600/5 and 800/5 ratio CTs shall be relay class 200 using ItI or GE model # 143, 145, 307, 309, 389, 685 or 785.
The 1000/5 and 1200/5 ratio CTs shall be relay class 200 and 400 respectively using ItI or GE model # 143, 145, 307, 309, 389, 685 or 785 . The 1600/5 ratio CTs shall be relay class 400 using ItI or GE model # 143, 145, 307, 309, 389, 685 or 785 . The 2000/5 ratio CTs shall be relay class 800 using ItI or GE model # 307 and 309.
4. All wiring for CTs shall be #10 AWG stranded SIS type wire.
5. All Ion Meter CT wiring shall be wired to shorting blocks before being wired to the ABB test block. All wiring from the test block to the meter shall be tagged per the Vendor supplied interconnection drawings. Test block shall be ABB style FT-1 and Cat # 129A514G01 with clear covers.

D. Submittals

1. Designer Submittals

- a. The protective devices short circuit and over current protection coordination study shall accompany unit substation submittals and the study shall certify all its components and the substation meets or exceeds the electrical system requirement. Study shall include all 480V feeder breakers in switchgear.

2. Construction Documents

Submit the following construction documents:

Product Data

- a. Submit manufacturer's catalog data for secondary unit substations and components including construction details and component and device specifications.

Shop Drawings Information

Submit project-specific shop drawings including the following:



- a. Front and side views of enclosures with overall dimension shown.
- b. Conduit entrance locations and requirements
- c. Nameplate legends
- d. Size and number of bus bars per phase, neutral, and ground.
- e. Primary selector device, transformer, secondary main-tie-main devices, instrument and metering details.
- f. Instruction for handling and installation of the unit substation.
- g. Electrical characteristics including voltage, frame size and trip ratings, withstand ratings, and time-current curves of equipment and components.

Certified Test Reports

- a. Provide factory transformer certified loss evaluation report.
- b. Provide field test reports and certify that the system is in compliance with test parameters.

Field Measurements

- a. Make necessary field measurements and provide equipment layout diagram to confirm that equipment shall fit in allocated space in full compliance with minimum required clearances specified in National Electrical Code.

Operations and Maintenance Data

- a. Provide overcurrent protective device adjusting and testing instructions.
- b. O & M Manuals shall include bus tightening intervals and procedures, and overcurrent protective device maintenance procedures.

E. Product Standards

Products shall conform to the following standards:



1. ANSI C57.1201
2. NEMA PB-2, 1995
3. Latest Codes and Standards
4. Latest D.O.E. Efficiency on Transformers

F. Manufacturers

Subject to compliance with the design requirements, provide unit substation by one of the following manufacturers:

4. Square D
5. General Electric
3. Cutler-Hammer/Eaton
4. ABB



G. Equipment

1. Power fuses shall be provided by Bussmann E-rated, GE Type EJ, or Shawmut Type CL-14.

H. Accessories or Special Features

Unit substation transformer standard features:

1. Stainless steel diagrammatic nameplate mounted on transformer enclosure.
2. Provide provisions for lifting and jacking unit into place.
3. Base suitable for rolling and skidding parallel to centerline.
4. Equip 120 VAC space heaters with thermostat.
5. Transformer high temperature monitor with local audible and visual alarm and contacts for remote alarm.
6. Each substation shall have a trolley lifting mechanism for the removal of circuit breakers.

I. Extra Materials

1. One spare set of three 15 kV or 5 Kv power fuses shall be required.

J. Special Requirements

1. Frame and cover printed operating instructions for unit substations, including key interlocking, control sequences, and emergency procedures, with clear acrylic plastic. Insert instructions in a fabricated frame of finished wood or metal and mount on front of unit substation.

K. Installation Guidelines

1. Install unit substations on 4 inches high concrete housekeeping pad with 2 inches wider and longer than substation widest and longest section.
2. Tack weld or bolt substation support footings to channel-iron sills embedded in the concrete pad. Install sills level and grout flush with pad surface.
3. Ground all metal parts of the unit substation to main electrical ground bus at two locations.



4. Tighten all electrical connectors and terminals according to manufacturer's published torque values or as specified in UL 486A and UL 486B.
5. Remove temporary lifting eyes, channels, brackets, and temporary blocking of moving parts from substation units and components.
6. Unit substation shall be accessible front and rear.

L. Field Quality Control

1. Field Quality Control Testing
 - a. Engage a factory-authorized service representative to supervise the field assembly of components, connections, preliminary testing, controls and safeties adjustment. Replace damaged and malfunctioning components and provide service result report in writing.
 - b. Owner will engage a qualified independent testing agency or an approved manufacturer's service organization to perform specific acceptance testing.
 - c. Perform visual and mechanical inspection and electrical tests stated in NETA ATS or submit equivalent manufacturer's startup procedures.
 - d. Perform load interrupter switchgear testing in accordance with NETA ATS, Section 7.5 Standards or approved equivalent manufacturer's startup procedures.
 - e. Perform air transformer testing in accordance with NETA ATS, Section 7.2 Standards or approved equivalent manufacturer's startup procedures.
 - f. Perform low voltage switchgear testing in accordance with NETA ATS, Section 7.2 Standards or approved equivalent manufacturer's startup procedures.
 - g. After the electrical testing is complete and the substation has been energized, demonstrate product and control capability in compliance with requirements.
 - h. Remove and replace malfunctioning components with new units and retest.
 - i. Provide certified reports that the system is in compliance with test parameters.
 - j. All equipment shall be vacuumed and cleaned prior to energization.



2. Commissioning

If this portion of the project includes commissioning, verify that insertions in the project specifications have been made that refer to the commissioning procedures in the commissioning specification section. Verify that the systems and equipment identified in this section of the standards, and listed in the project specifications, do not conflict with commissioning procedures for testing and training.

3. Monitoring

After Substantial Completion, when requested by owner, but no more than 6 months after Final Acceptance, commissioning agent will perform the following voltage monitoring and adjusting:

- a. During a period of normal load cycles as evaluated by owner, perform 7 days of 3-phase voltage recording at the low voltage switchgear outgoing section of the unit substation. Use voltmeters with calibration traceable to National Institute of Standards and Technology standards and with a chart speed of no less than 1 inch (25 mm) per hour. Voltage unbalance greater than 1 percent between phases or deviation of any phase voltage from the nominal value by more than plus or minus 5 percent during the test period is unacceptable.
- b. If test results are unacceptable, take the following corrective actions, as appropriate:
 - Adjust transformer taps
 - Rebalance loads
 - Send a written request to the electrical utility for voltage adjustment
- c. Repeat monitoring, after corrective action has been performed, until satisfactory results are obtained.
- d. Provide a written report describing voltage monitoring performance and corrective action taken.



M. Cleaning and Adjusting

1. Clean and vacuum interior of separate enclosures to remove construction debris, dirt, and shipping material. Wipe all buses and terminals to remove dust with water or alcohol damped cloth.

N. Startup and Training

Engage a factory-authorized service representative to train owner's maintenance personnel as specified below:

1. Train owner's maintenance personnel on procedures and schedules related to startup and shutdown, troubleshooting, servicing, and preventive maintenance.
2. Review data in the maintenance manuals. Refer to Division 1, [Section 01730 Project Execution and Closeout](#).
3. Review data in the maintenance manuals. Refer to Division 1, [Section 01782 Operation and Maintenance Data](#).
4. Schedule training with owner, through Architect, with at least 7 days' advance notice.

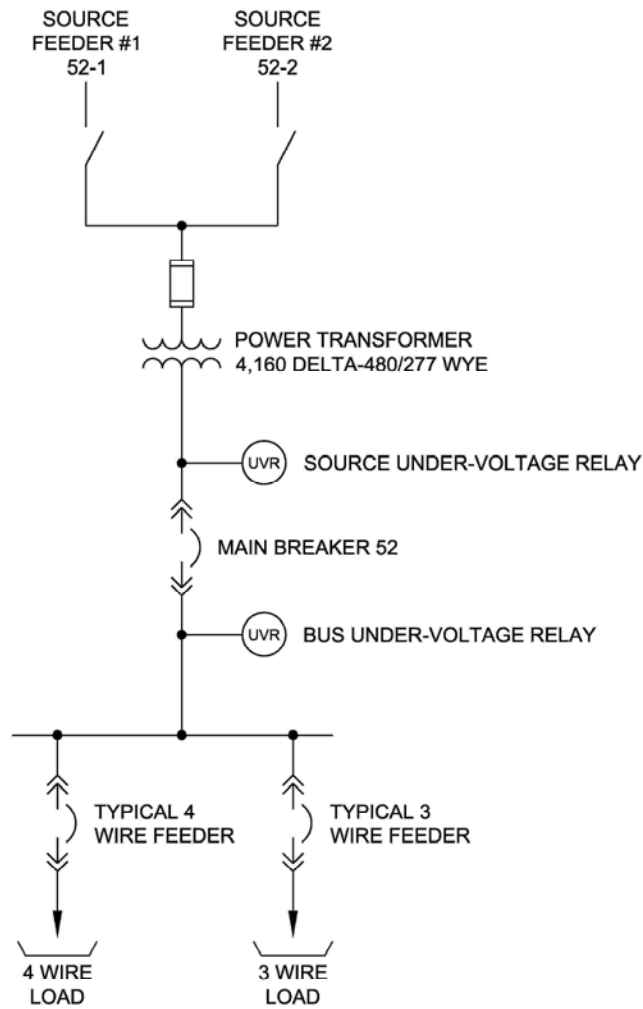

FIGURE 1-1



End of Section