



# Fire Resistant Design and Detailing: Firewalls, Fire Barriers and Fire Partitions

---

Presented by Ethan Martin, PE  
Northwest Regional Director  
WoodWorks for Non-residential Construction





“The Wood Products Council” is a Registered Provider with The American Institute of Architects Continuing Education Systems (AIA/CES), Provider #G516.

Credit(s) earned on completion of this course will be reported to **AIA CES** for AIA members. Certificates of Completion for both AIA members and non-AIA members are available upon request.

This course is registered with **AIA CES** for continuing professional education. As such, it does not include content that may be deemed or construed to be an approval or endorsement by the AIA of any material of construction or any method or manner of handling, using, distributing, or dealing in any material or product.

---

Questions related to specific materials, methods, and services will be addressed at the conclusion of this presentation.

# Course Description

---

With an increase in wood-frame buildings, more designers are seeking information on code-compliant and constructible detailing. Many are unsure of the code's requirements for details, specifically at the intersection of rated assemblies and where structure and fire protection meet. This presentation will focus interior fire rated assemblies such as firewalls, fire barriers and fire partitions. Discussion will include issues of fire-resistance rating continuity, allowable uses of wood framing in rated assemblies, and allowable penetrations.



# Learning Objectives

1. Review methods for determining fire-resistance ratings.
2. Discuss detailing aspects of fire resistance for fire walls, fire barriers and fire partitions including material and assembly options, continuity, structural stability, and penetrations.
3. Explore requirements for horizontal assemblies.
4. Understand requirements for individual encasement of beams and columns.



# Outline

---

- Review of Fire Resistance Methods
- Interior Fire Rated Wall Assemblies
  - Fire Walls
  - Fire Barriers
  - Fire Partitions/Corridors
- Horizontal Assemblies

# Fire Resistance Ratings – IBC 703.2

Fire resistance of elements, components or assemblies shall be based on testing (ASTM E119):

- UL Listings
- Gypsum Catalog
- Proprietary Manufacturer Tests
- Industry Documents: such as AWC's DCA3

OR.....

**UL** ONLINE CERTIFICATIONS DIRECTORY [Home](#) [Quick Guide](#) [Contact Us](#) [UL.com](#)

**Design No. U334**  
BXUV.U334  
Fire-resistance Ratings - ANSI/UL 263

[Page Bottom](#)

**Design/System/Construction/Assembly Usage Disclaimer**

- Authorities Having Jurisdiction should be consulted in all cases as to the particular requirements covering the installation and use of UL Certified products, equipment, system, devices, and materials.
- Authorities Having Jurisdiction should be consulted before construction.
- Fire resistance assemblies and products are developed by the design submitter and have been investigated by UL for compliance with applicable requirements. The published information cannot always address every construction nuance encountered in the field.
- When field issues arise, it is recommended the first contact for assistance be the technical service staff provided by the product manufacturer noted for the design. Users of fire resistance assemblies are advised to consult the general Guide Information for each product category and each group of assemblies. The Guide Information includes specifics concerning alternate materials and alternate methods of construction.
- Only products which bear UL's Mark are considered Certified.

**BXUV - Fire Resistance Ratings - ANSI/UL 263**  
**BXUV7 - Fire Resistance Ratings - CAN/ULC-S101 Certified for C**

[See General Information for Fire-resistance Ratings - ANSI/UL 263](#)  
[See General Information for Fire Resistance Ratings - CAN/ULC-S101 Certified for Canada](#)

**Design No. U334**  
October 29, 2014  
Bearing Wall Rating – 2 HR.  
STC Rating - 62 (See Item 7)

This design was evaluated using a load design method other than the Limit States Design Method. For jurisdictions employing the Limit States Design Method, such as Canada, be used – See Guide BXUV or BXUV7

\* Indicates such products shall bear the UL or cUL Certification Mark for jurisdictions employ (such as Canada), respectively.



GA-600 - 2012 FIRE RESISTANCE DESIGN MANUAL

**GYPSUM ASSOCIATION**

20<sup>th</sup> Edition  
GA-600-2012



**FIRE RESISTANCE DESIGN MANUAL**



SOUND CONTROL

**GYPSUM SYSTEMS**



**Design for Code Acceptance**

**Fire Rated Wood Floor and Wall Assemblies**

Building Code Requirements For occupancies such as stores, apartments, offices, and other commercial and industrial uses, building codes commonly require floor/ceiling and wall assemblies to be fire-resistance rated in accordance with standard fire tests.

Depending on the application, wall assemblies may need to be rated either from one side or both sides. For specific exterior wall applications, the 2000 International Building Code (IBC), the 1999 National Building Code (NBC), and the 1999 Standard Building Code (SBC) allow wood-frame, wood-sided walls to be tested for exposure to fire from the inside only. Rating for both interior and exterior exposure is only required when the wall has a fire separation distance of less than 5 feet. Code recognition of one and two-hour wood-frame wall systems is also predicated on successful fire and hose stream testing in accordance with ASTM E119, Standard Test Methods for Fire Tests of Building Construction Materials.

**Fire Tested Assemblies**  
Fire-rated wood-frame assemblies can be found in a number of sources including the IBC. Underwriters

Directory, Intertek Testing Services' Directory of Listed Products, and the Gypsum Association's Fire Resistance Design Manual. The American Forest & Paper Association (AF&PA) and its members have tested a number of wood-frame fire-rated assemblies. Descriptions of these successfully tested assemblies are provided in Table 1 for one-hour rated wall assemblies, Table 2 for two-hour rated wall assemblies, Table 3 for one-hour rated floor/ceiling assemblies, and Table 4 for two-hour rated floor/ceiling assemblies. Additional tests are being conducted and the Tables will be updated periodically.

**Conclusions**  
Wood-frame assemblies are used in architectural designs because of their adaptability to style preferences, ease and economics of construction, and energy-saving performance.



# Fire Resistance Ratings – IBC 703.3

Methods for determining fire resistance:

- Prescriptive designs per IBC 721.1

**TABLE 721.1(3)—continued  
MINIMUM PROTECTION FOR FLOOR AND ROOF SYSTEMS<sup>a, 9</sup>**

FLOOR OR ROOF CONSTRUCTION	ITEM NUMBER	CEILING CONSTRUCTION	THICKNESS OF FLOOR OR ROOF SLAB (inches)				MINIMUM THICKNESS OF CEILING (inches)			
			4 hours	3 hours	2 hours	1 hour	4 hours	3 hours	2 hours	1 hour
28. Wood I-joint (minimum I-joint depth 9 <sup>1</sup> / <sub>4</sub> " with a minimum flange depth of 1 <sup>1</sup> / <sub>2</sub> " and a minimum flange cross-sectional area of 2.25 square inches; minimum web thickness of 3 <sup>1</sup> / <sub>8</sub> " @ 24" o.c. Unfaced fiberglass insulation or mineral wool insulation is installed between the I-joists supported on the upper surface of the flange by stay wires spaced 12" o.c.	28-1.1	Base layer of 5 <sup>1</sup> / <sub>8</sub> " Type C gypsum wallboard attached directly to I-joists with 1 <sup>5</sup> / <sub>8</sub> " Type S drywall screws spaced 12" o.c. with ends staggered. Minimum 0.0179" thick hat-shaped 7 <sup>1</sup> / <sub>8</sub> -inch furring channel 16" o.c. (channels doubled at wallboard end joints), placed perpendicular to the joist and attached to each joist by 1 <sup>5</sup> / <sub>8</sub> " Type S drywall screws after the base layer of gypsum wallboard has been applied. The middle and face layers of 5 <sup>1</sup> / <sub>8</sub> " Type C gypsum wallboard applied perpendicular to the channel with end joints staggered. The middle layer is fastened with 1" Type S drywall screws spaced 12" o.c. The face layer is applied parallel to the middle layer but with the edge joints offset 24" from those of the middle layer and fastened with 1 <sup>5</sup> / <sub>8</sub> " Type S drywall screws 8" o.c. The joints shall be taped and covered with joint compound.	—	—	—	Varies	—	—	2 <sup>3</sup> / <sub>4</sub>	—

# Fire Resistance Ratings – IBC 703.3

Methods for determining fire resistance:

- Prescriptive designs per IBC 721.1
- Calculated Fire Resistance per IBC 722.6

**TABLE 722.6.2(1)**  
**TIME ASSIGNED TO WALLBOARD MEMBRANES<sup>a, b, c, d</sup>**

DESCRIPTION OF FINISH	TIME <sup>e</sup> (minutes)
$\frac{3}{8}$ -inch wood structural panel bonded with exterior glue	5
$\frac{15}{32}$ -inch wood structural panel bonded with exterior glue	10
$\frac{19}{32}$ -inch wood structural panel bonded with exterior glue	15
$\frac{3}{8}$ -inch gypsum wallboard	10
$\frac{1}{2}$ -inch gypsum wallboard	15
$\frac{5}{8}$ -inch gypsum wallboard	30
$\frac{1}{2}$ -inch Type X gypsum wallboard	25
$\frac{5}{8}$ -inch Type X gypsum wallboard	40
Double $\frac{3}{8}$ -inch gypsum wallboard	25
$\frac{1}{2}$ -inch + $\frac{3}{8}$ -inch gypsum wallboard	35
Double $\frac{1}{2}$ -inch gypsum wallboard	40

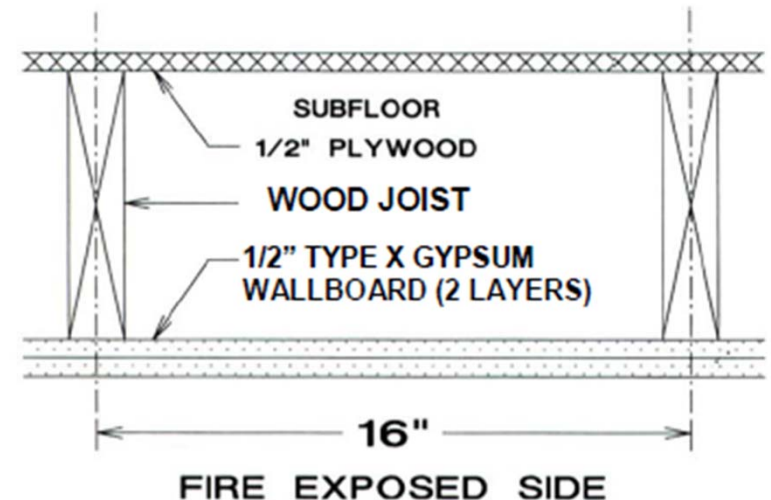

1/2 inch Type X Gypsum wallboard	=	25 minutes
1/2 inch Type X Gypsum wallboard	=	25 minutes
Wood joists	=	10 minutes
<b>Combined Assembly Fire Resistance Rating</b>		<b>= 60 minutes</b>

**Figure 2 Floor/Ceiling Assembly**

# Fire Resistance Ratings – IBC 703.3

Methods for determining fire resistance:

- Prescriptive designs per IBC 721.1
- Calculated Fire Resistance per IBC 722.6
- Calculated Fire Resistance per IBC 722.1



**Table 16.2.1A Effective Char Rates and Char Depths (for  $\beta_n = 1.5$  in./hr.)**

Required Fire Endurance (hr.)	Effective Char Rate, $\beta_{eff}$ (in./hr.)	Effective Char Depth, $a_{char}$ (in.)
1-Hour	1.8	1.8
1½-Hour	1.67	2.5
2-Hour	1.58	3.2

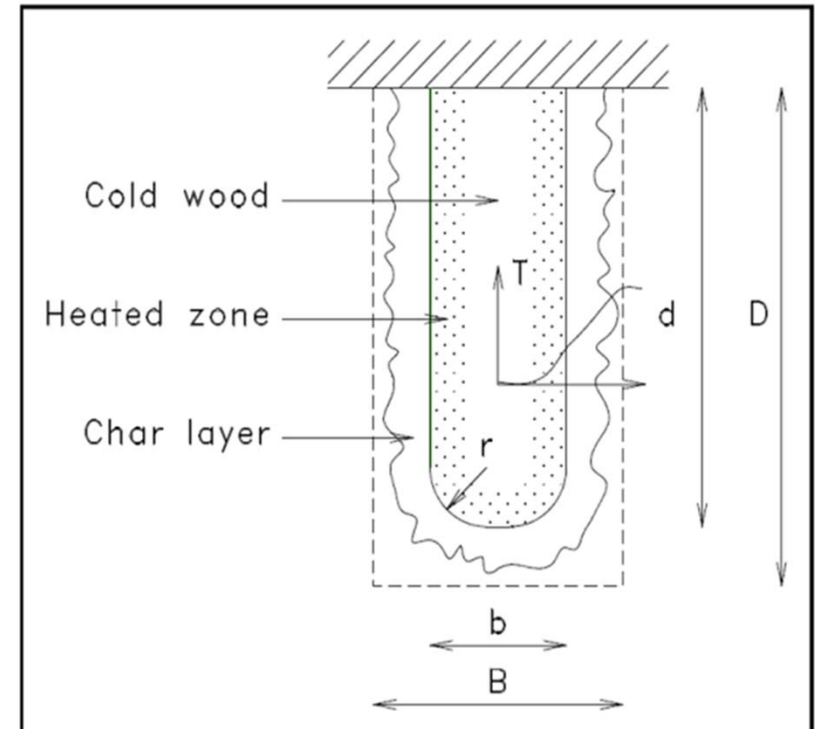



# Fire Resistance Ratings – IBC 703.3

## Methods for determining fire resistance:

- Prescriptive designs per IBC 721.1
- Calculated Fire Resistance per IBC 722
- Fire-resistance designs documented in sources
- Engineering analysis based on a comparison
- Fire-resistance designs certified by an approved agency

 **ONLINE CERTIFICATIONS DIRECTORY** [Home](#) [Quick Guide](#) [Contact Us](#) [UL.com](#)

**Design No. U334**  
**BXUV U334**  
**Fire-resistance Ratings - ANSI/UL 263**

[Page Bottom](#)

**Design/System/Construction/Assembly Usage Disclaimer**

- Authorities Having Jurisdiction should be consulted in all cases as to the particular requirements covering the installation and use of UL Certified products, equipment, system, devices, and materials.
- Authorities Having Jurisdiction should be consulted before construction.
- Fire resistance assemblies and products are developed by the design submitter and have been investigated by UL for compliance with applicable requirements. The published information cannot always address every construction nuance encountered in the field.
- When field issues arise, it is recommended the first contact for assistance be the technical service staff provided by the product manufacturer noted for the design. Users of fire resistance assemblies are advised to consult the general Guide Information for each product category and each group of assemblies. The Guide Information includes specifics concerning alternate materials and alternate methods of construction.
- Only products which bear UL's Mark are considered Certified.

**BXUV - Fire Resistance Ratings - ANSI/UL 263**  
**BXUV7 - Fire Resistance Ratings - CAN/ULC-S101 Certified for Canada**

[See General Information for Fire-resistance Ratings - ANSI/UL 263](#)  
[See General Information for Fire Resistance Ratings - CAN/ULC-S101 Certified for Canada](#)

**Design No. U334**  
 October 29, 2014  
**Bearing Wall Rating — 2 HR.**  
**STC Rating - 62 (See Item 7)**

This design was evaluated using a load design method other than the Limit States Design Method (e.g., Working Stress Design Method). For jurisdictions employing the Limit States Design Method, such as Canada, a load restriction factor shall be used — See Guide [BXUV](#) or [BXUV2](#)

\* Indicates such products shall bear the UL or cUL Certification Mark for jurisdictions employing the UL or cUL Certification (such as Canada), respectively.

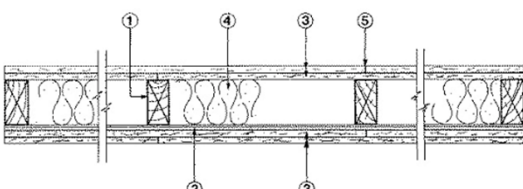

**Design for Code Acceptance**

**3**

**Fire Rated Wood Floor and Wall Assemblies**

Building Code Requirements For occupancies such as stores, apartments, offices, and other commercial and industrial uses, building codes commonly require floor/ceiling and wall assemblies to be fire-resistance rated in accordance with standard fire tests.

Depending on the application, wall assemblies may need to be rated either from one side or both sides. For specific exterior wall applications, the 2000 *International Building Code (IBC)*, the 1999 *National Building Code (NBC)*, and the 1999 *Standard Building Code (SBC)* allow wood-frame, wood-sided walls to be tested for exposure to fire from the inside only. Rating for both interior and exterior exposure is only required when the wall has a fire separation distance of less than 5 feet. Code recognition of one and two-hour wood-frame wall systems is also predicated on successful fire and hose stream testing in accordance with ASTM E119, *Standard Test Methods for Fire Tests of Building Construction Materials*.

**Fire Tested Assemblies**  
 Fire-rated wood-frame assemblies can be found in a number of sources including the IBC, Underwriters

Directory, Intertek Testing Services' *Directory of Listed Products*, and the Gypsum Association's *Fire Resistance Design Manual*. The American Forest & Paper Association (AF&PA) and its members have tested a number of wood-frame fire-rated assemblies. Descriptions of these successfully tested assemblies are provided in [Table 1](#) for one-hour rated wall assemblies, [Table 2](#) for two-hour rated wall assemblies, [Table 3](#) for one-hour rated floor/ceiling assemblies, and [Table 4](#) for two-hour rated floor/ceiling assemblies. Additional tests are being conducted and the Tables will be updated periodically.

**Conclusions**  
 Wood-frame assemblies are used in architectural designs because of their adaptability to style preferences, ease and economies of construction, and energy-saving performance.

GA-600 - 2012 FIRE RESISTANCE DESIGN MANUAL

 **GYPSUM ASSOCIATION**

20<sup>th</sup> Edition  
 GA-600-2012

 **FIRE RESISTANCE DESIGN MANUAL**

 **SOUND CONTROL**

**GYPSUM SYSTEMS**

UL LISTED PRODUCT

# Outline

---

- Review of Fire Resistance Methods
- Interior Fire Rated Wall Assemblies
  - Fire Walls
  - Fire Barriers
  - Fire Partitions/Corridors
- Horizontal Assemblies



# Fire-Resistance Rated Wall Assemblies

---

**Fire-Resistance Rating:** The period of time a building element, component or assembly maintains the ability to confine a fire, continues to perform a given structural function, or both, as determined by the tests, or the methods based on tests, prescribed in Section 703.

Tested under a standardized test fire exposure for a given duration to:

1. Prevent the passage of flame and temperature rise from one side to the other
2. Continue to provide vertical structural support when exposed to fire and elevated temperatures



**Fire Confinement**

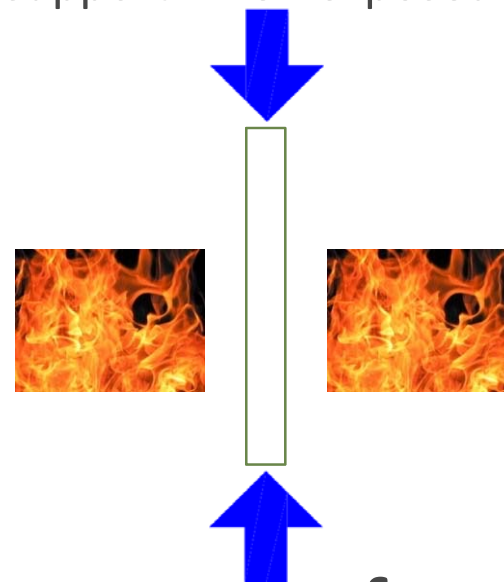

**Structural Performance**

# Interior Fire-Rated Walls: Differences

---

## Fire walls

- Building Separation
- Openings are protected and limited
- Continuous from foundation to/through roof and exterior wall to/through exterior wall
- Structural stability

## Fire Barrier

- Shafts, Occupancy Separation
- Openings are protected and limited
- Continuous from floor through concealed space at each level

## Fire Partition:

- Dwelling Unit Separation; Corridors
- Openings are protected
- May terminate at a fire rated floor/ceiling/roof assembly

# Fire Walls – IBC 706

---

**EACH PORTION OF A BUILDING SEPARATED BY ONE OR MORE FIRE WALLS SHALL BE CONSIDERED TO BE A SEPARATE BUILDING.**

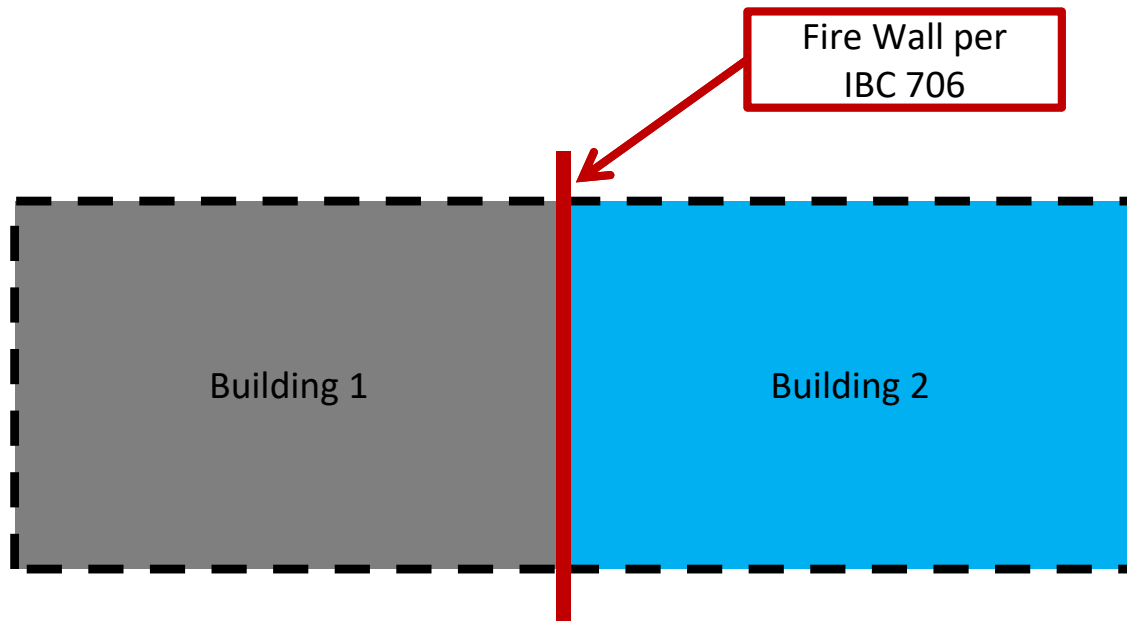

# Fire Walls – Ratings & Materials

---

**TABLE 706.4  
FIRE WALL FIRE-RESISTANCE RATINGS**

GROUP	FIRE-RESISTANCE RATING (hours)
A, B, E, H-4, I, R-1, R-2, U	3 <sup>a</sup>
F-1, H-3 <sup>b</sup> , H-5, M, S-1	3
H-1, H-2	4 <sup>b</sup>
F-2, S-2, R-3, R-4	2

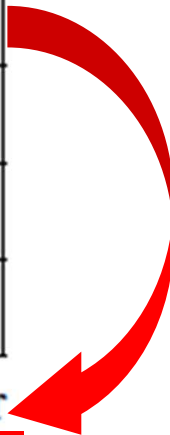

a. In Type II or V construction, walls shall be permitted to have a 2-hour fire-resistance rating.

b. For Group H-1, H-2 or H-3 buildings, also see Sections 415.6 and 415.7.

**IBC 706.3** – Fire walls shall be of any approved non-combustible materials.

**Exception:** Buildings of Type V construction

# Fire Walls – Ratings & Materials

---

Opportunity for Wood Framed Fire Walls:

- Permitted in type V Construction
- Fire Walls in type V Construction of A, B, E, R and several other occupancies may be 2 hour

Fire Walls in type III and IV construction are required to be constructed of non-combustible materials

- Opportunity for wood frame bearing walls on each side of fire wall to meet structural stability requirements

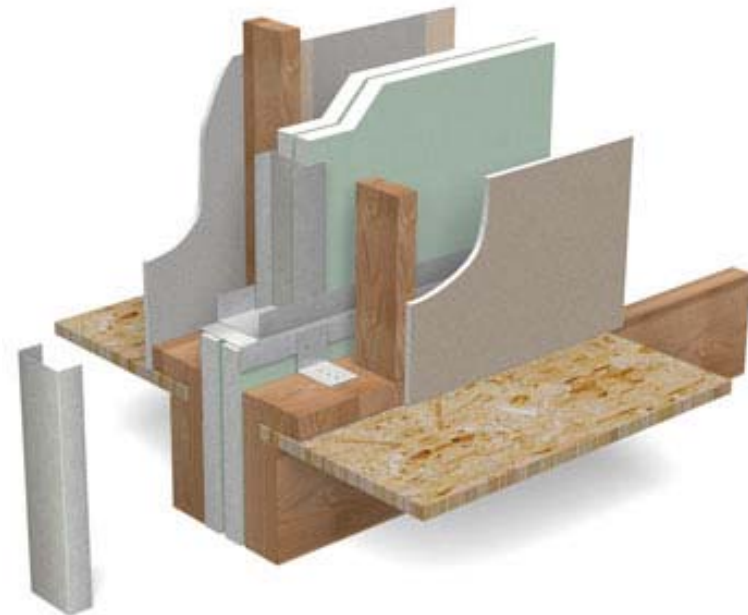

# Fire Walls – Horizontal Continuity

---

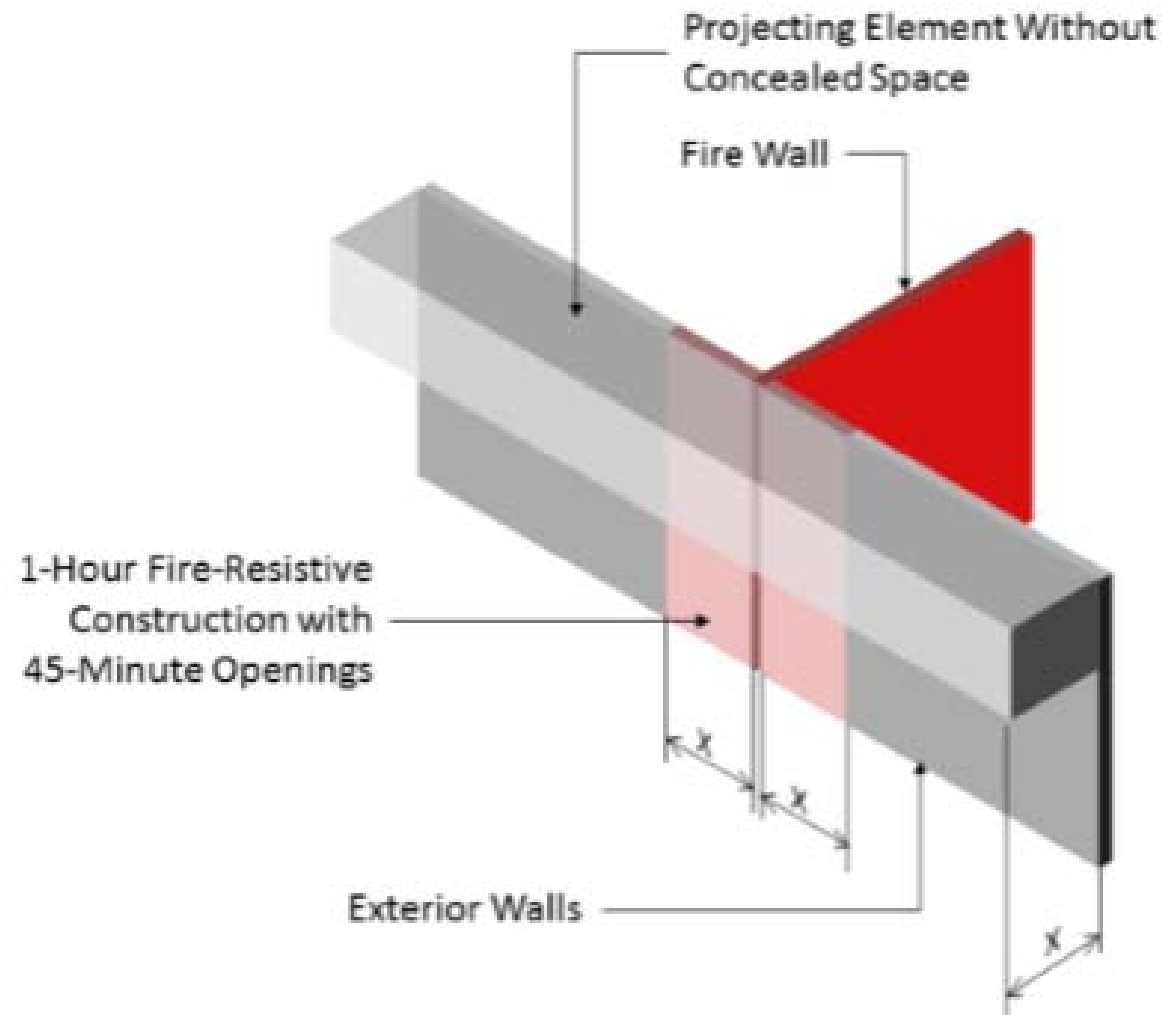
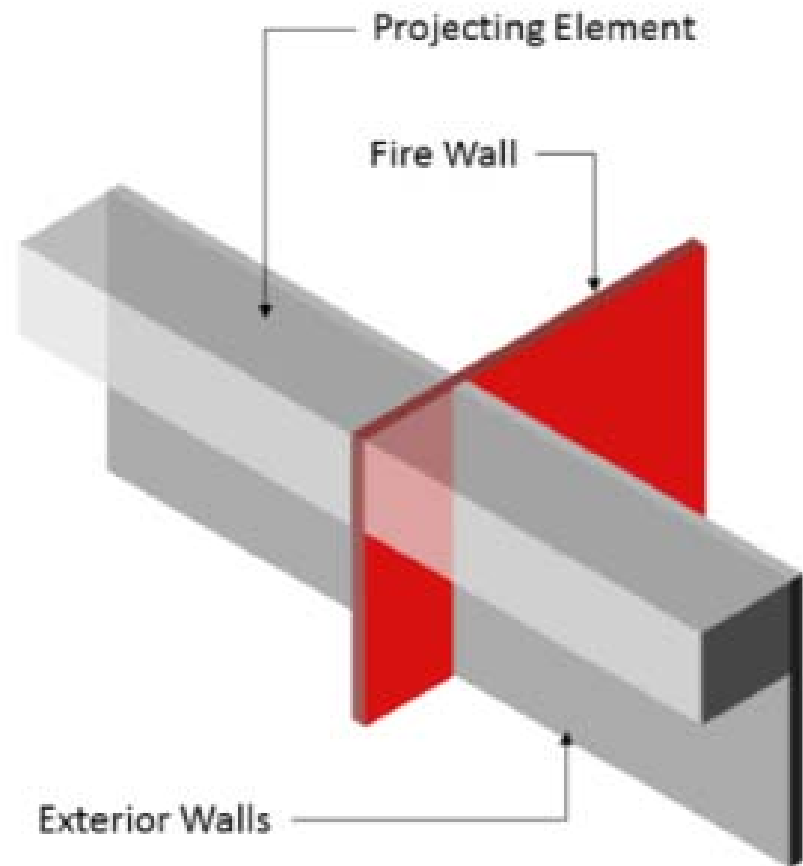

# Fire Walls – Horizontal Continuity

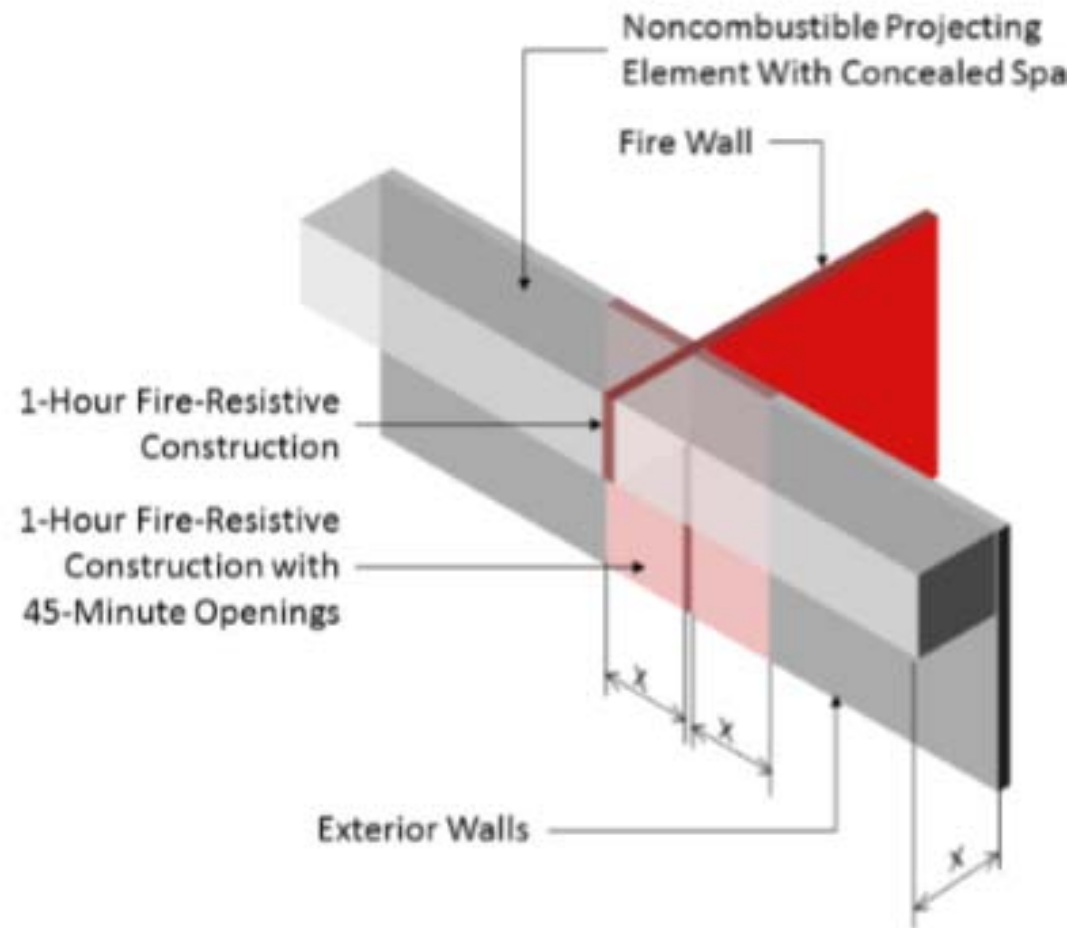
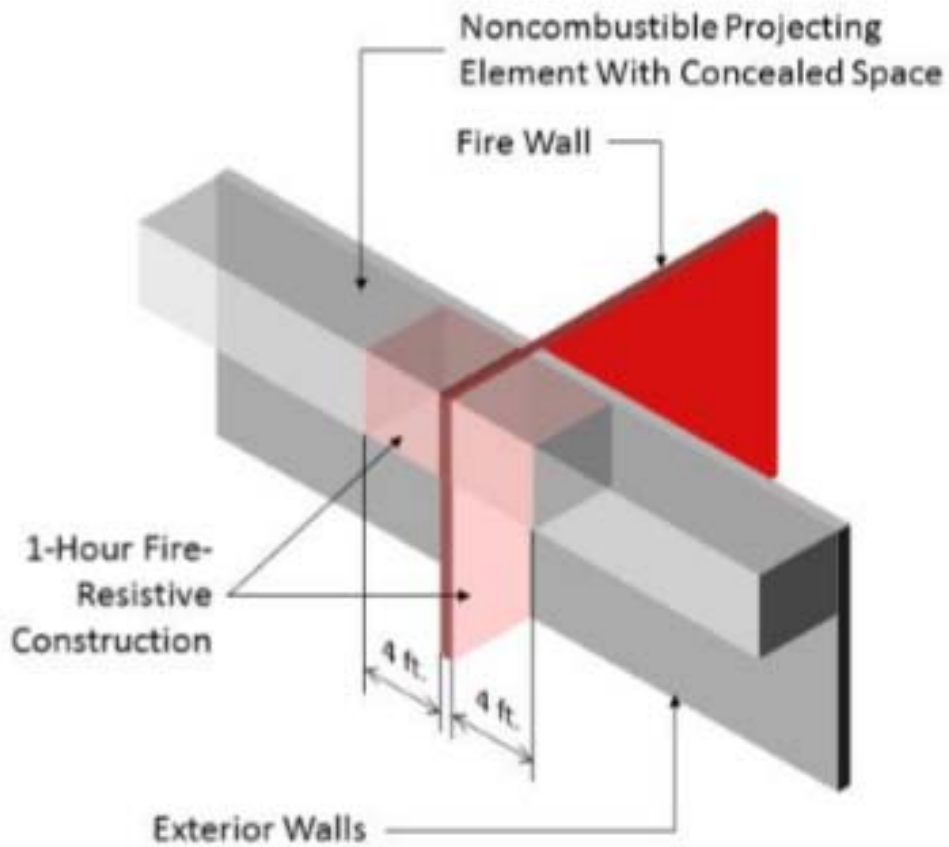



# Fire Walls – Horizontal Continuity

---

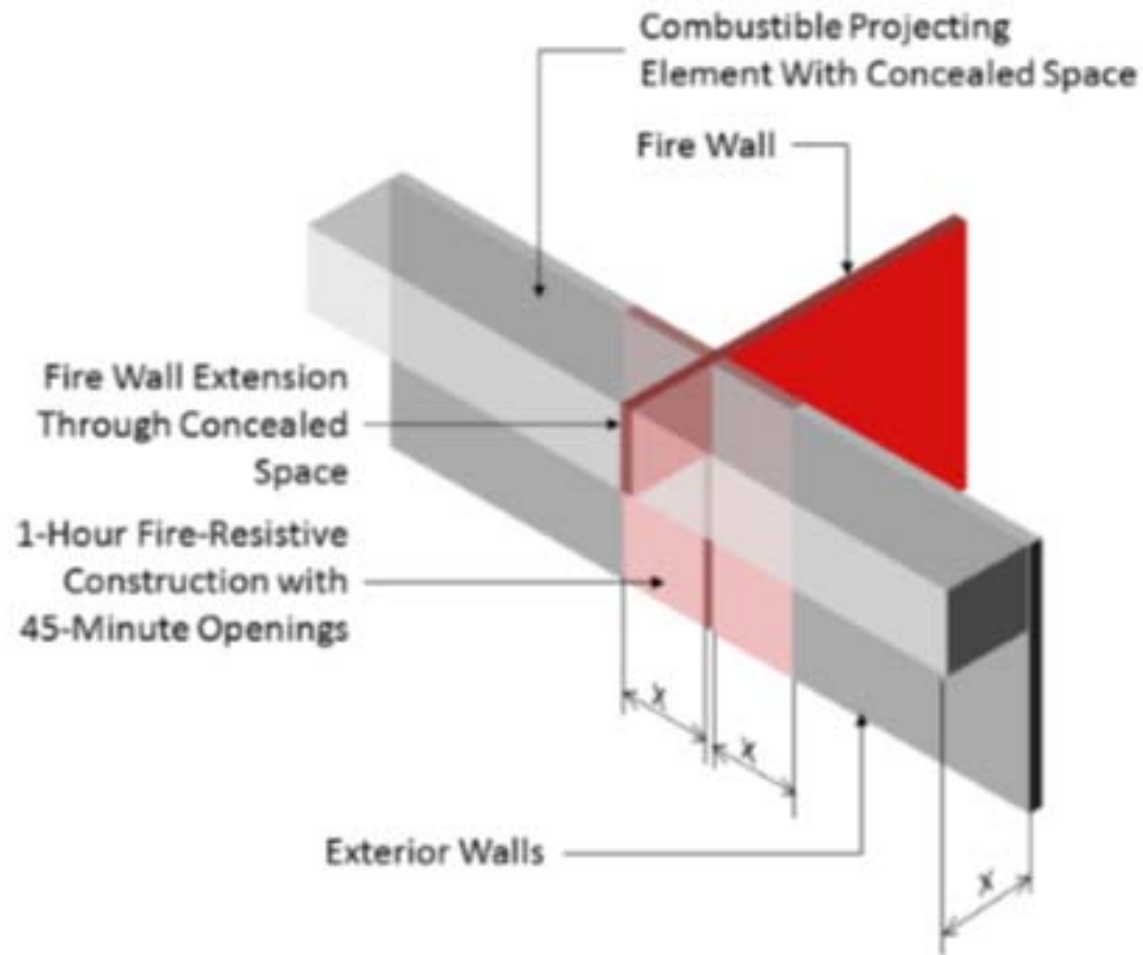

# Fire Walls – Vertical Continuity

---

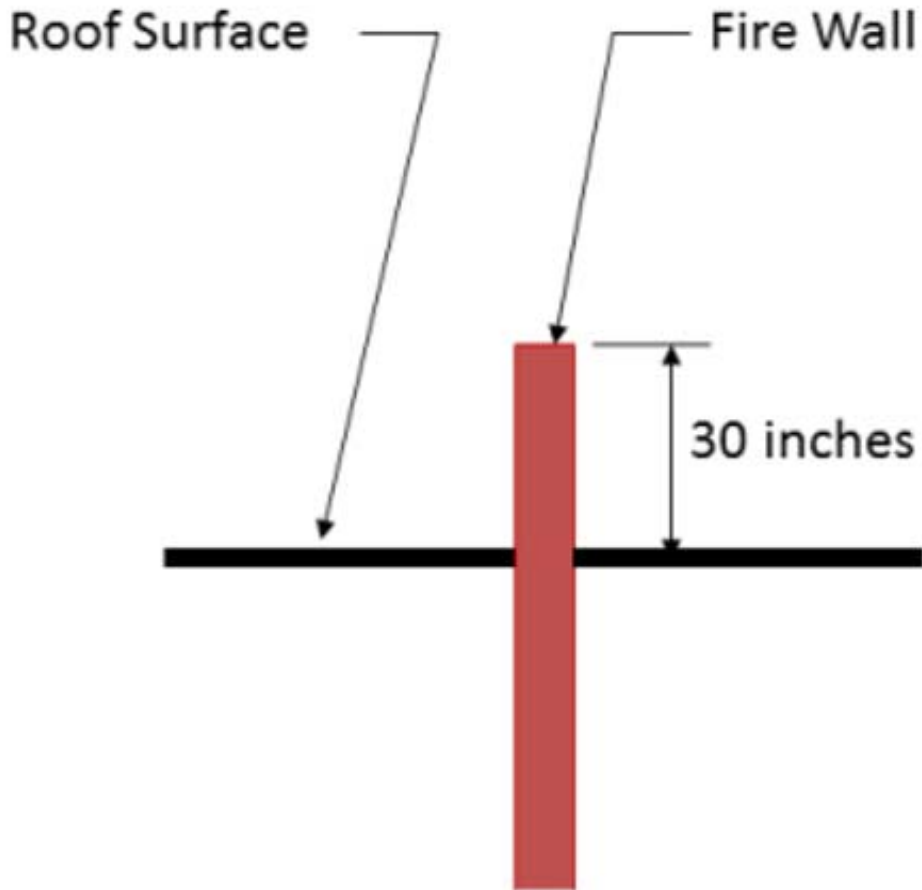

Typical Roof Condition

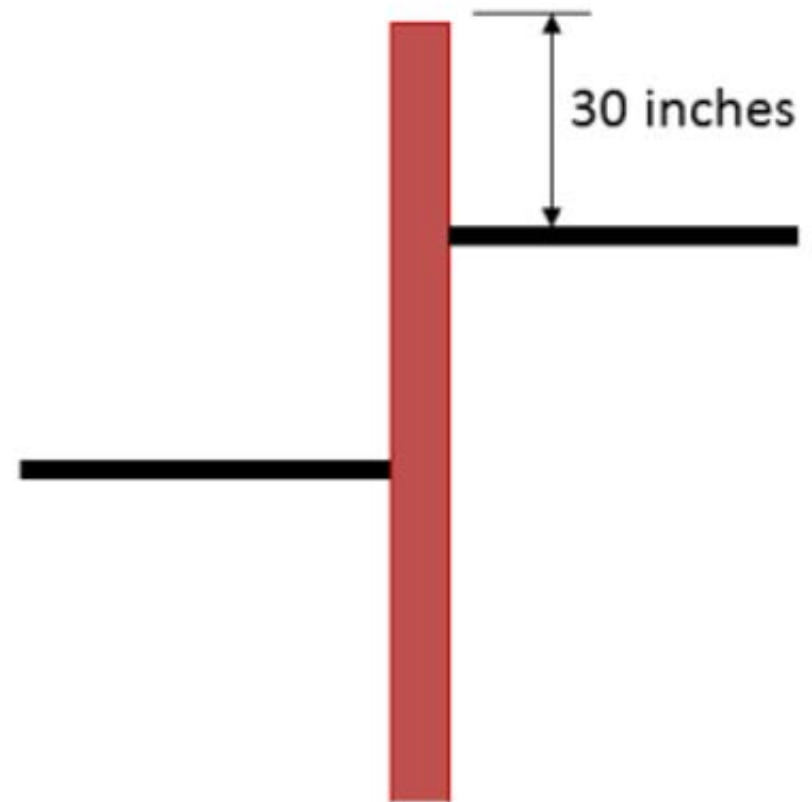

High-Low Roof Condition

# Fire Walls – Vertical Continuity

---

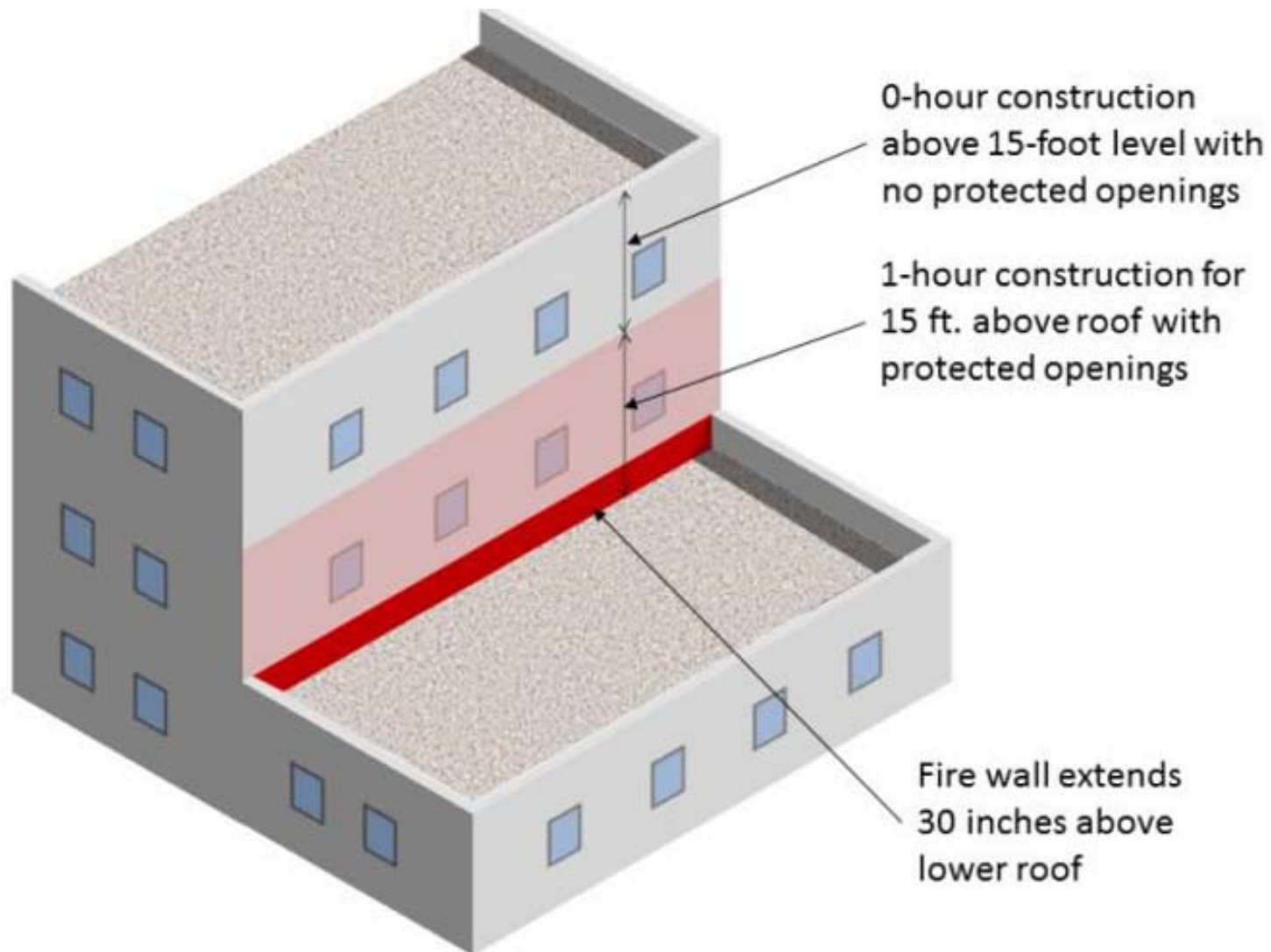

# Fire Walls – Vertical Continuity

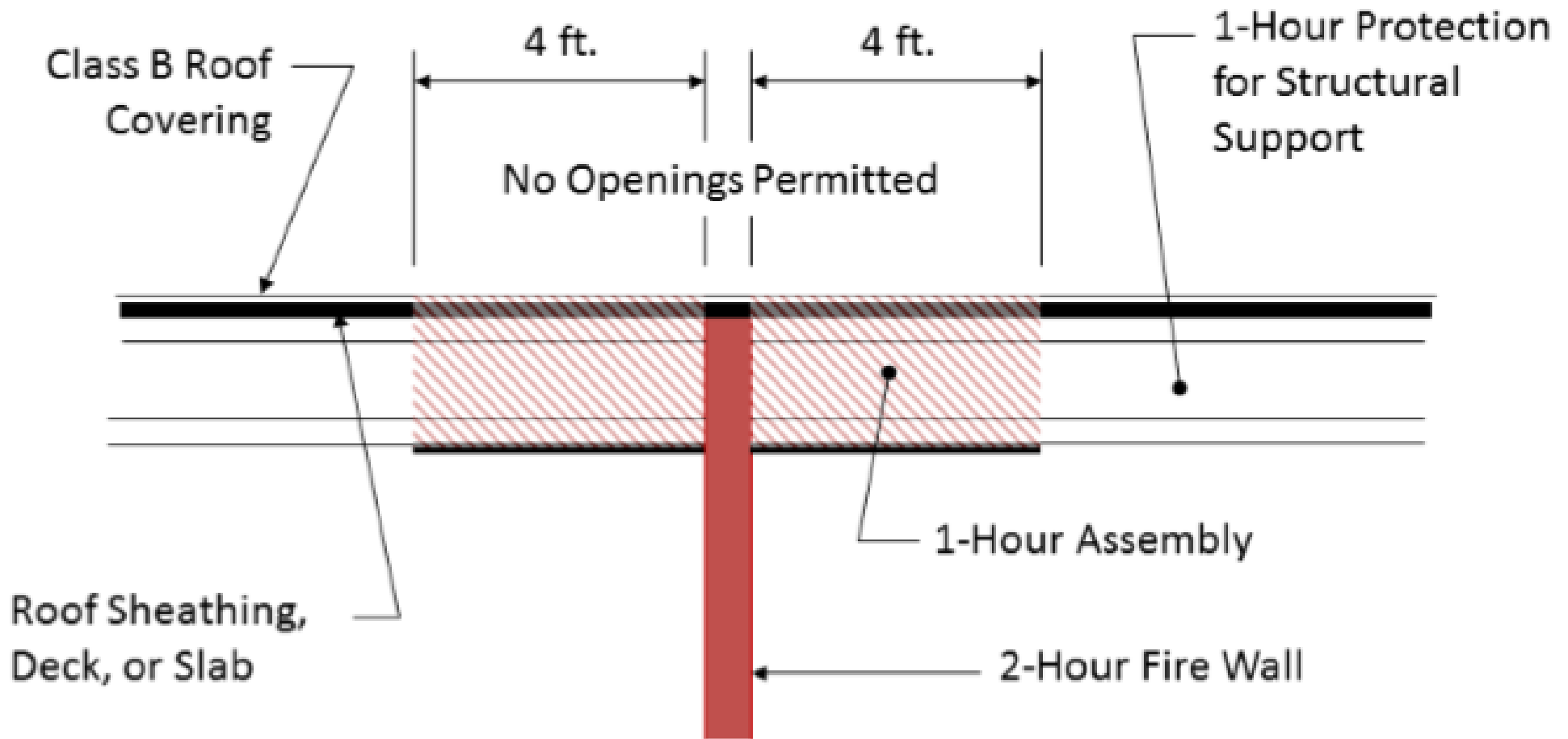

# Fire Walls – Vertical Continuity

---

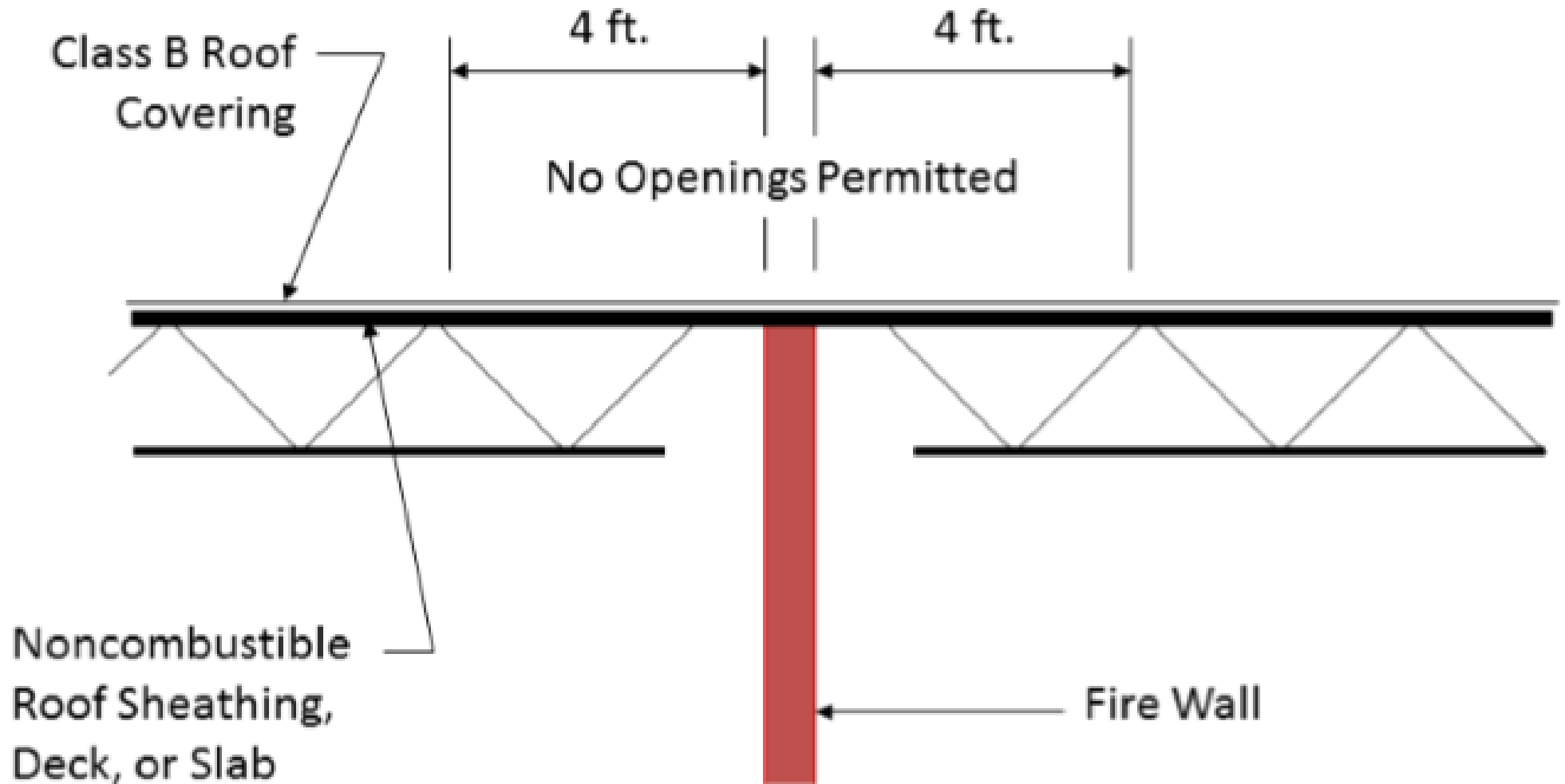

# Fire Walls – Vertical Continuity

---

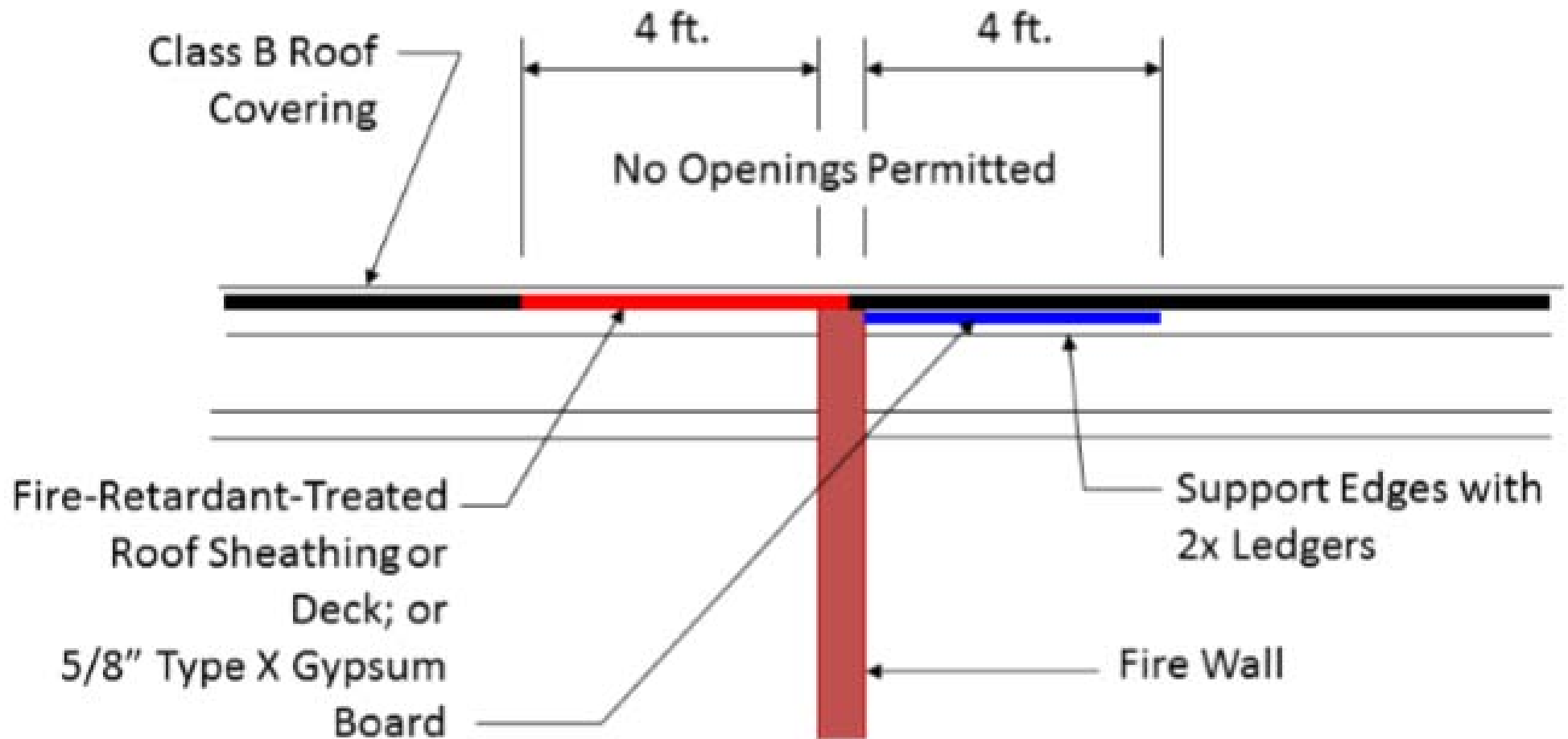

# Fire Walls – Structural Stability

## 706.2 Structural Stability:

Fire walls shall have sufficient structural stability under fire conditions to allow collapse of construction on either side without collapse of the wall for the duration of time indicated by the required fire-resistance rating or shall be constructed as double fire walls in accordance with NFPA 221.

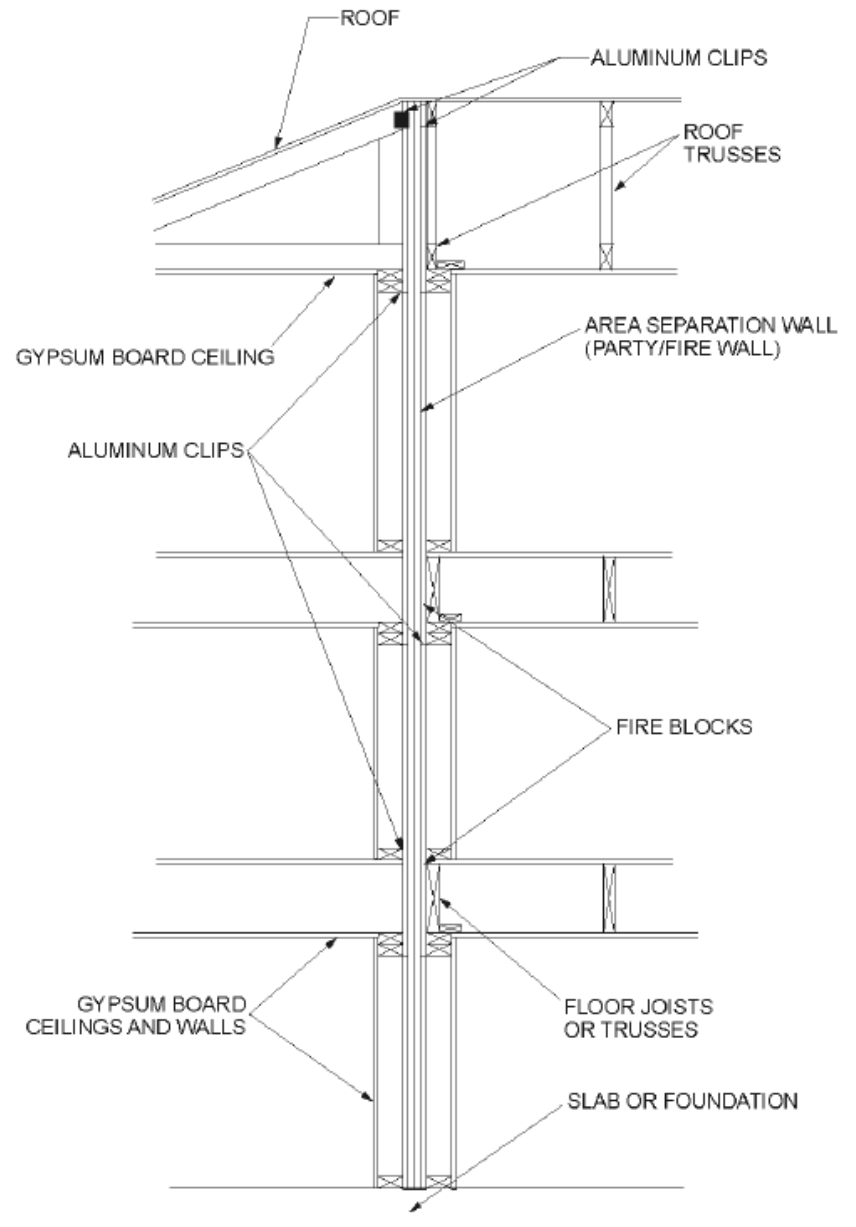



# NFPA 221

---

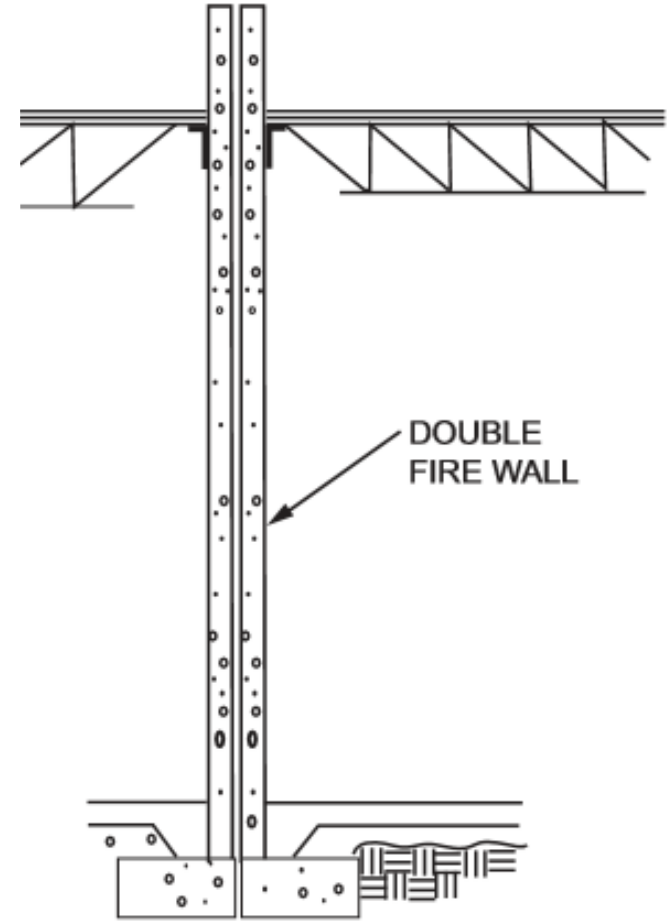
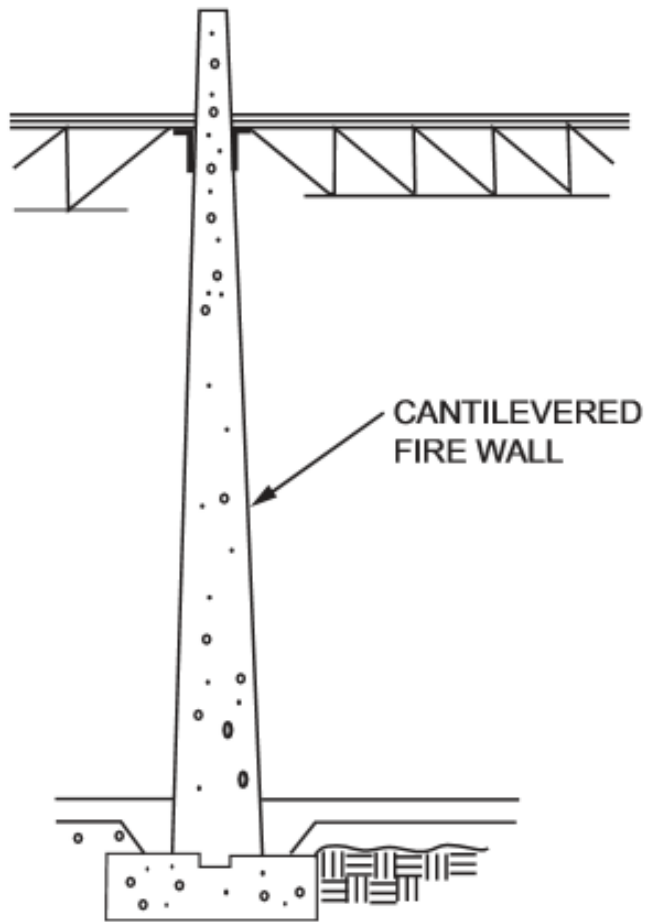
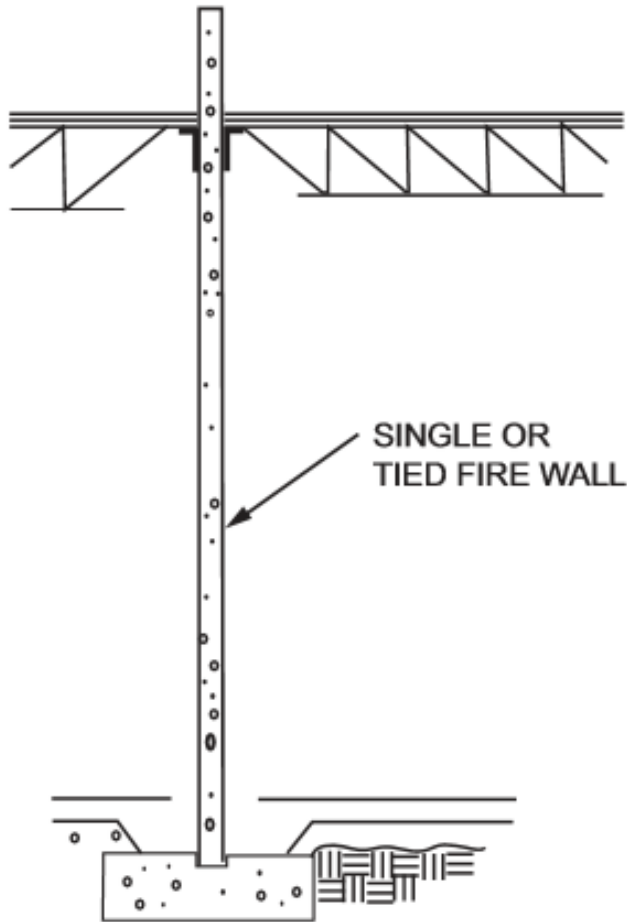

# NFPA 221 – Double Walls

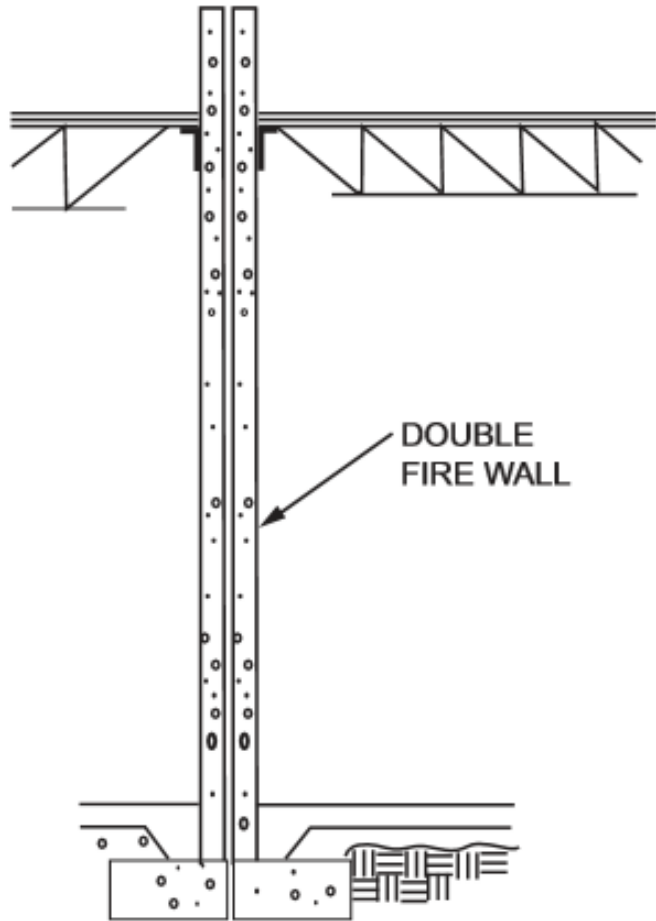

**4.5\* Double Wall Assemblies.** Where either wall of a double wall is laterally supported by a building frame with a fire resistance rating less than that required for the wall, double wall assemblies shall be considered to have a combined assembly fire resistance rating as specified in Table 4.5.

**Table 4.5 Fire Resistance Ratings for Double Wall Assemblies**

Fire Resistance Rating of Each Wall (hr)	Equivalent to Single Wall (hr)
3	4
2	3
1	2

# Construction

## Type:

- V

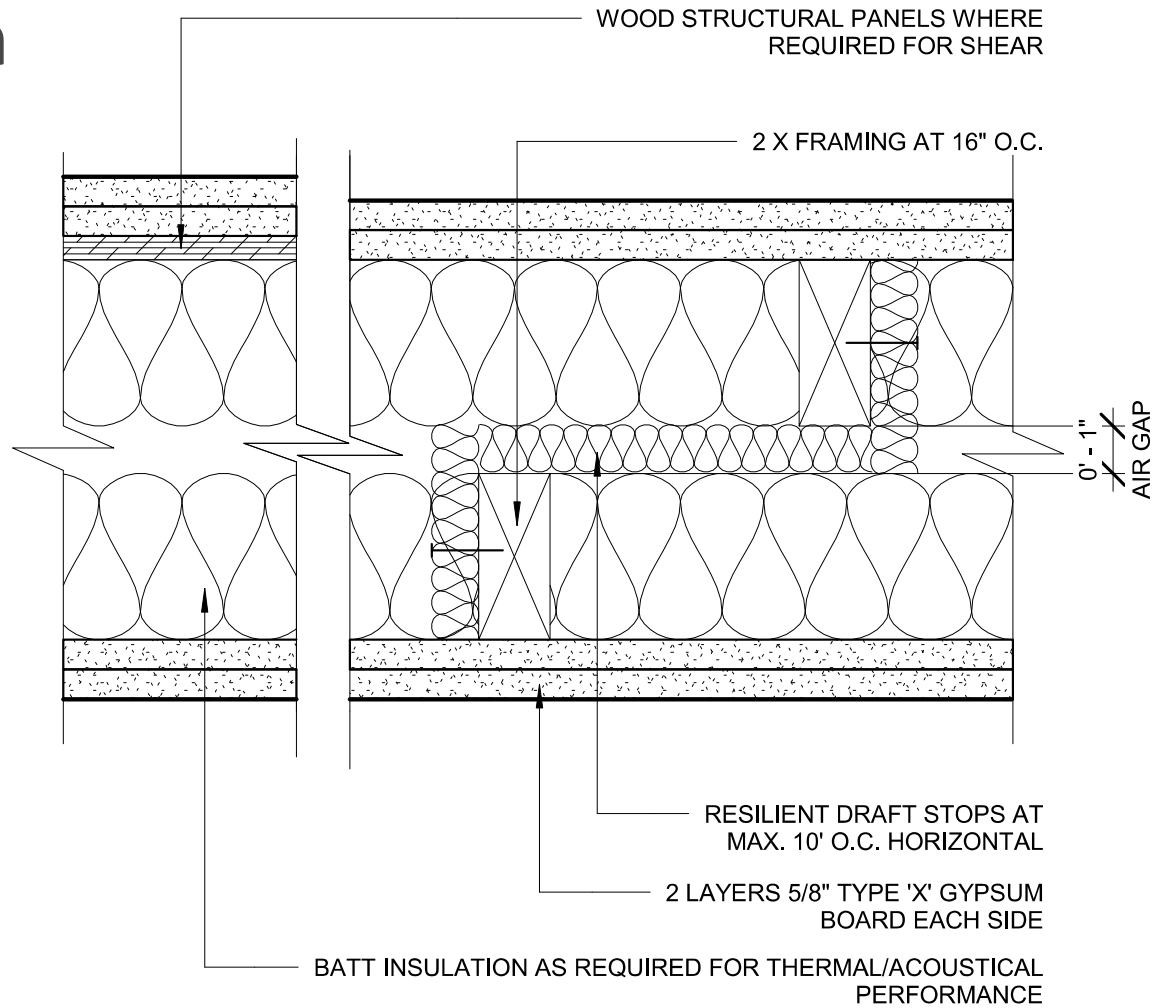

2-HOUR RATING PER GA FILE NO. WP 3820

## 2-HOUR DOUBLE STUD WALL

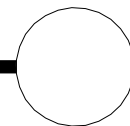

# 2 Hour Fire Wall Assembly

---

Construction

**GA FILE NO. WP 3810**

Type:

- V

<b>2 HOUR FIRE</b>	<b>55 to 59 STC SOUND</b>
------------------------	-------------------------------

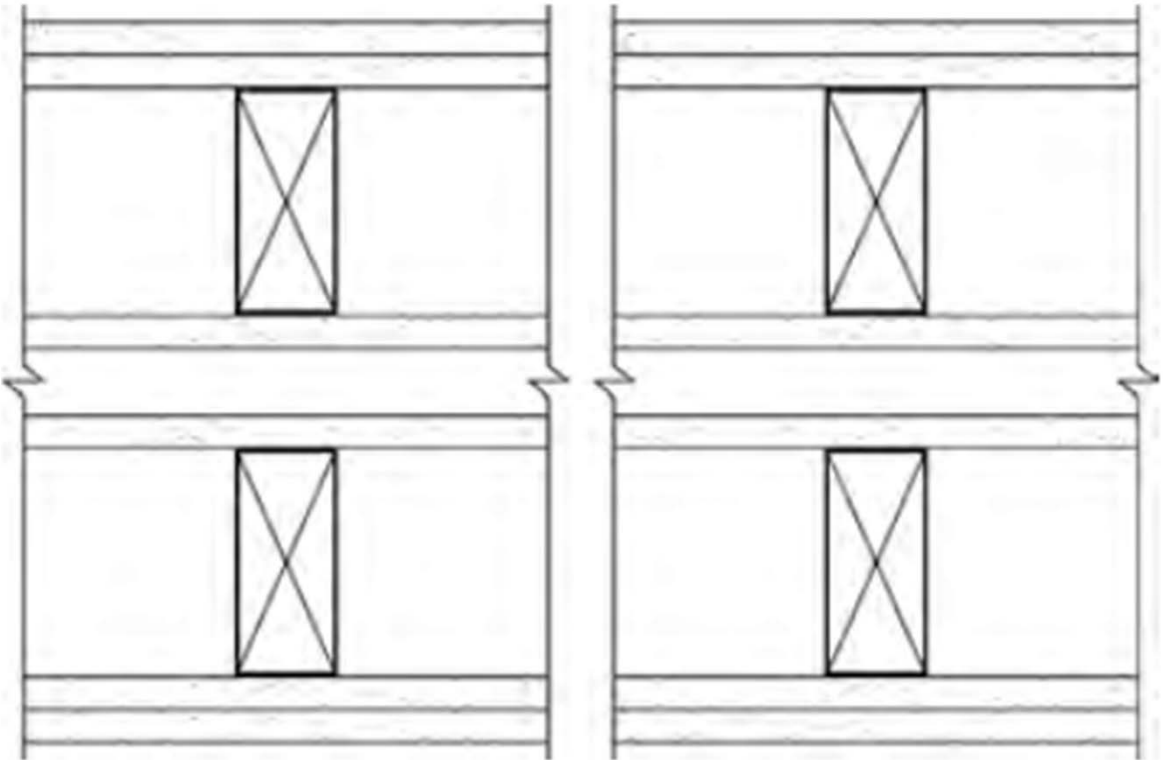

# 2 Hour Fire Wall Assembly

Construction

**GA FILE NO. ASW 1000**

Types:

- III
- IV
- V

**2 HOUR  
FIRE**

**60 to 64 STC  
SOUND**

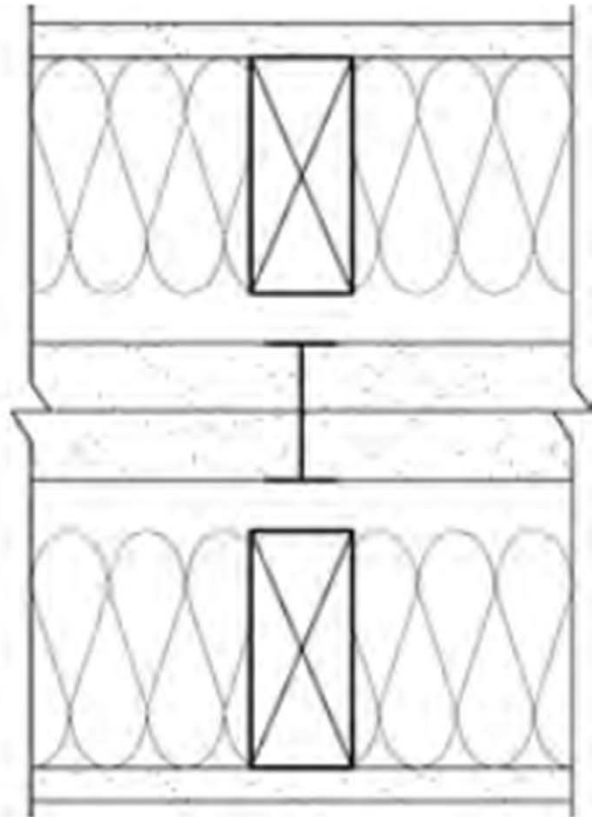
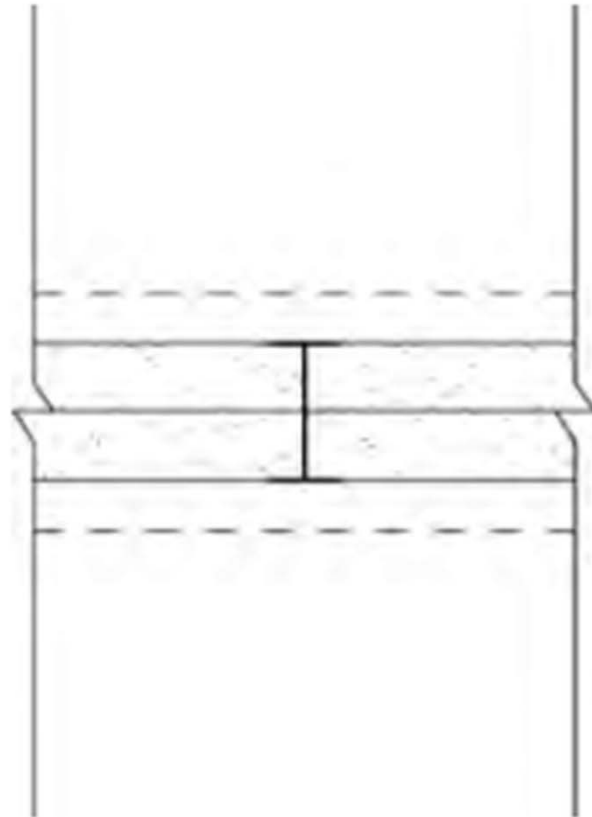

Also see UL  
U336

# 2 Hour Fire Wall Assembly

## Construction

### Types:

- III
- IV
- V

GA WP 1548

UL U411

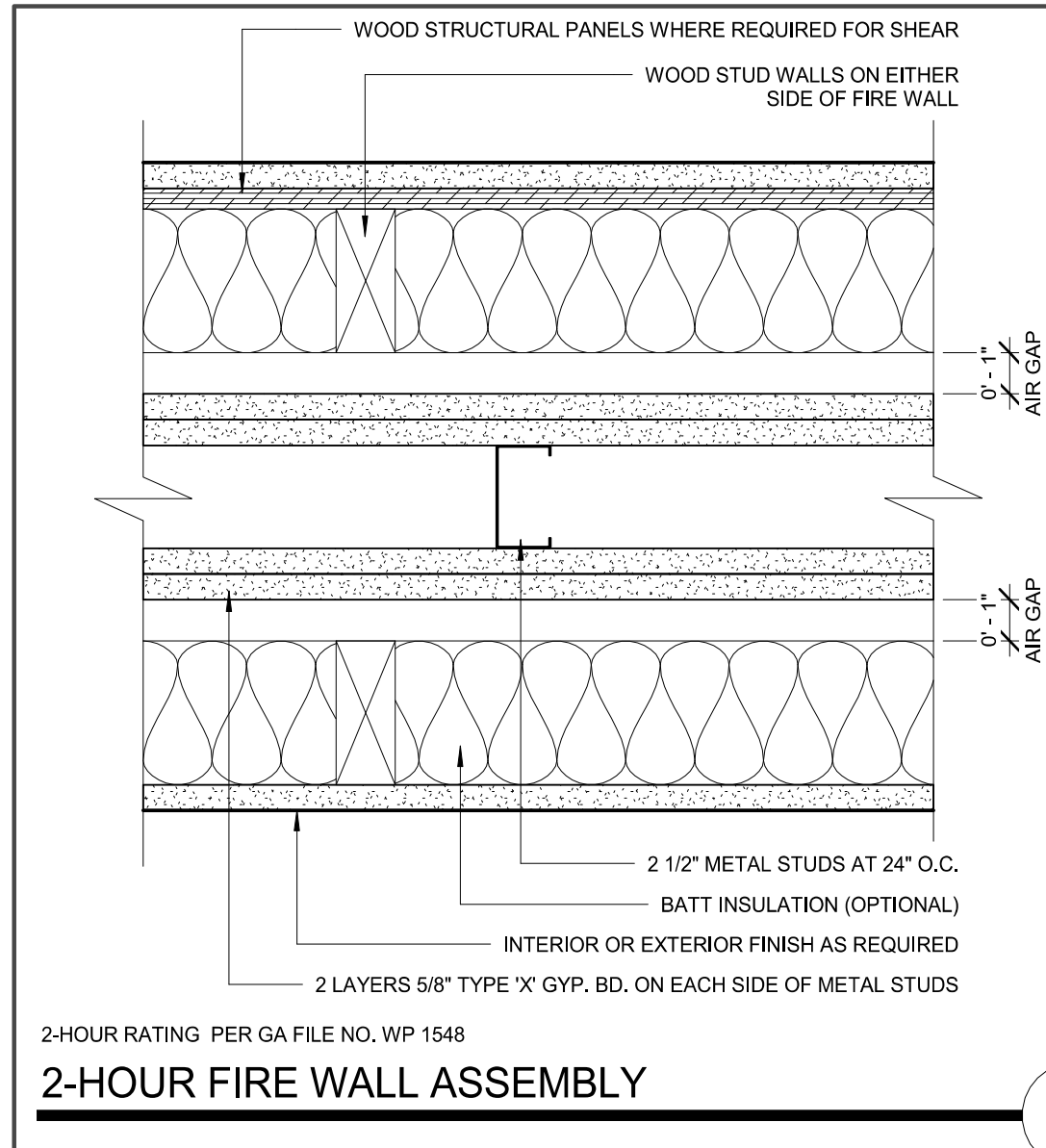

# 2

## Construction

### Types:

- III
- IV
- V

GA WP 1548

UL U411

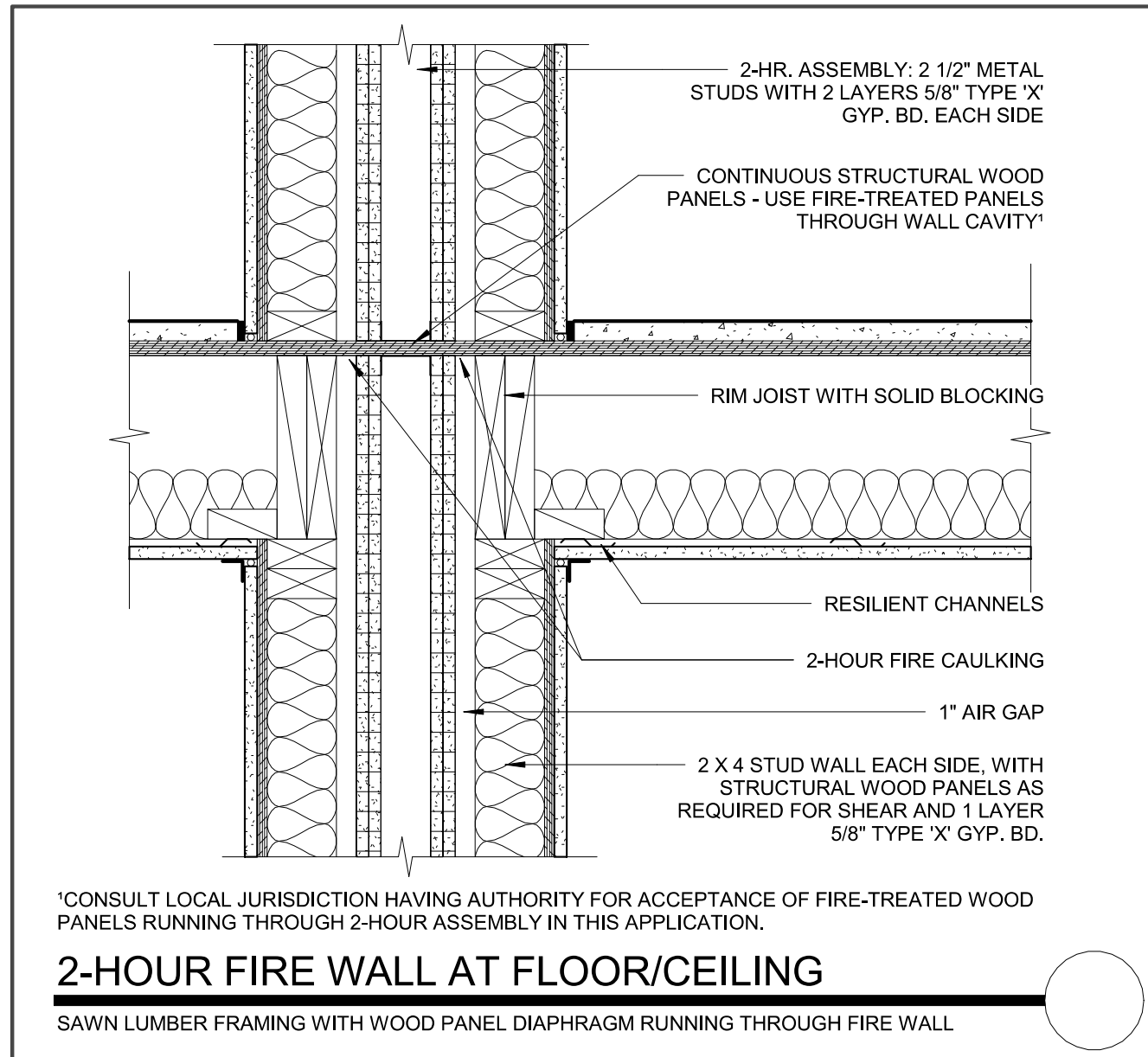



# 2 Hour Fire Wall Assembly

---

Construction

**GA FILE NO. ASW 1111**

Types:

- III
- IV
- V

<b>2 HOUR FIRE</b>	<b>50 to 54 STC SOUND</b>
------------------------	-------------------------------

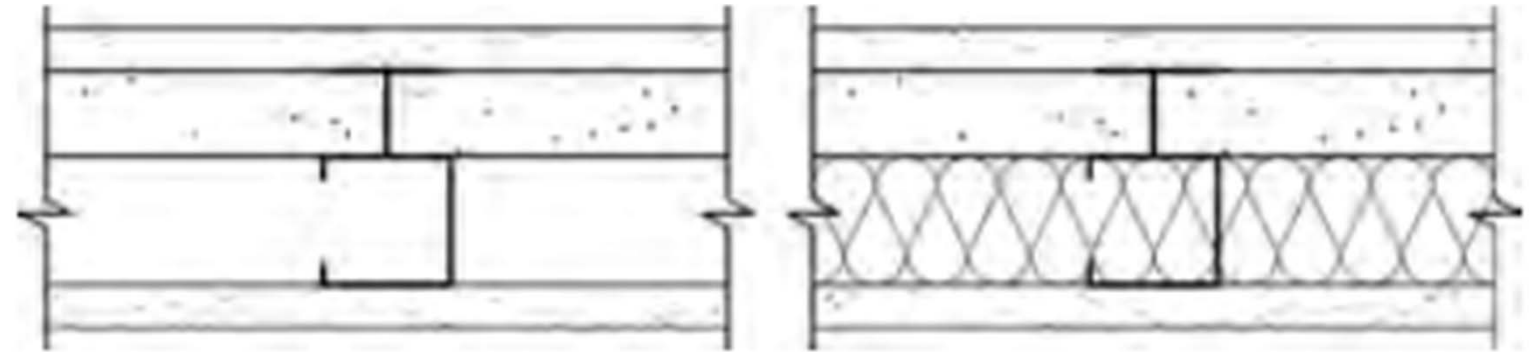

**Can install wood bearing wall on  
each side of 2 hour wall**

# 3 Hour Fire Wall Assembly

## Construction

### Types:

- III
- IV
- V

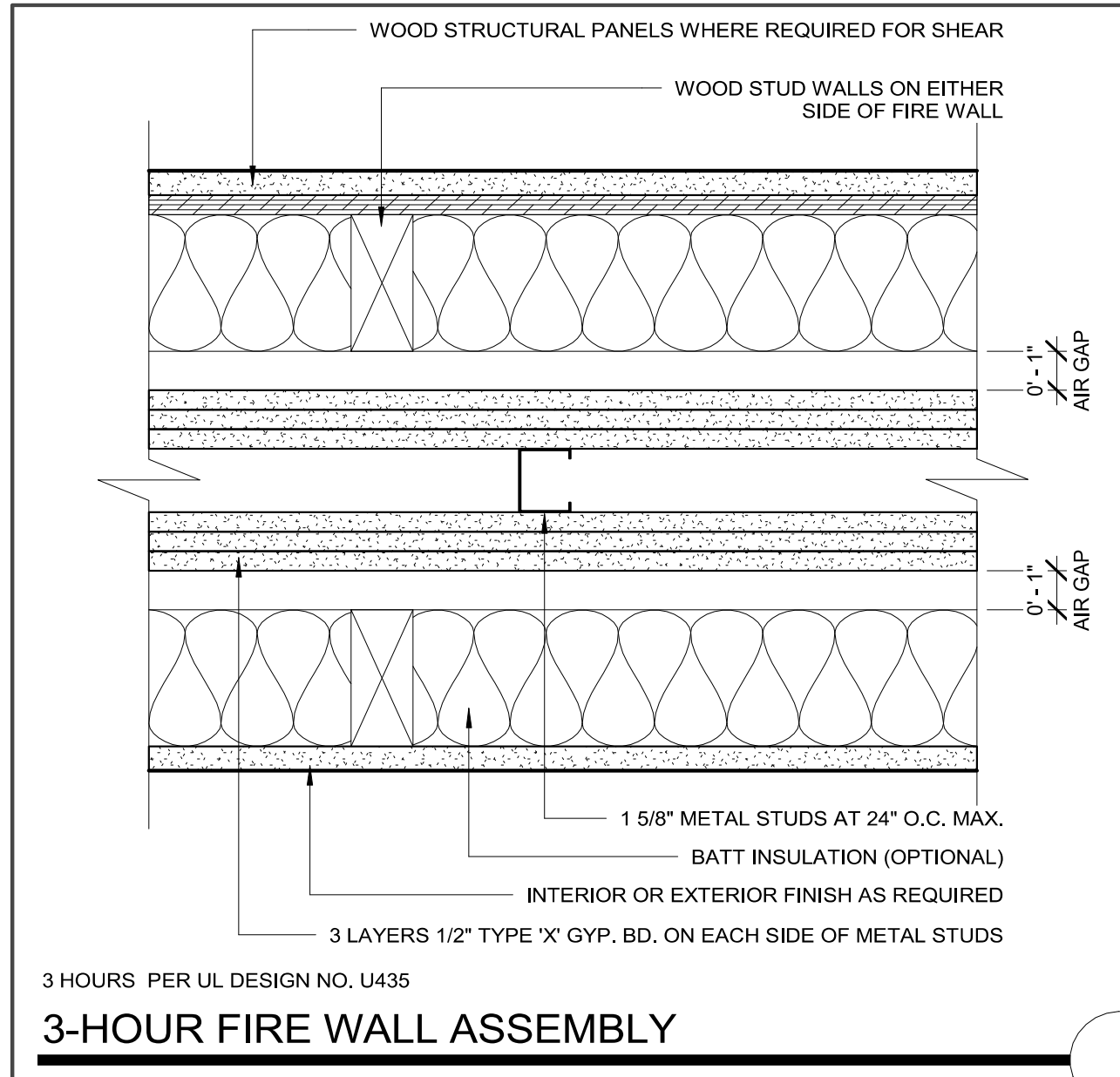

# 3 Hour Fire Wall Assembly

Construction

**GA FILE NO. ASW 2600**

Types:

- III
- IV
- V

**3 HOUR  
FIRE**

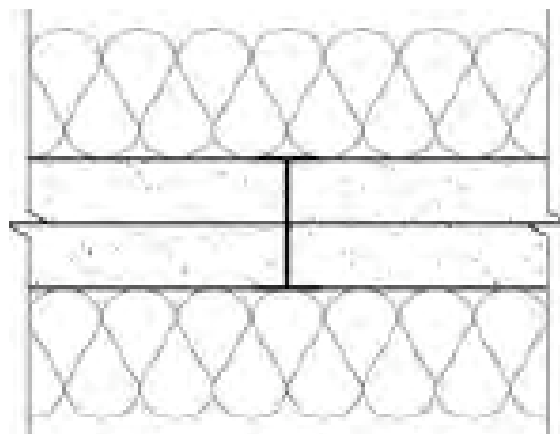

- (2) 1" Type X Gypsum
- 2" H Studs
- 2" mineral fiber insulation each side

Thickness: 6"  
Approx. Weight: 9.6 psf  
Fire Test: WHI-495-0393, 1-14-82

**Could install wood bearing wall on each side of 3 hour wall**

# 3 Hour Fire Wall Assembly

## 3 Hour Fire-Rated Construction

wt. 13

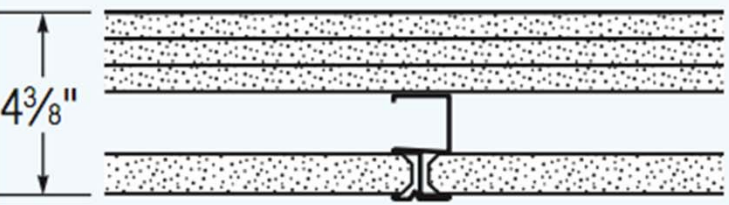

- 5/8" SHEETROCK FIRECODE C Core gypsum panels, face layer joints finished
- 2-1/2" USG C-H Studs 25 gauge 24" o.c.
- 1" SHEETROCK gypsum liner panels

**UL Des U415,  
System G**

wt. 13

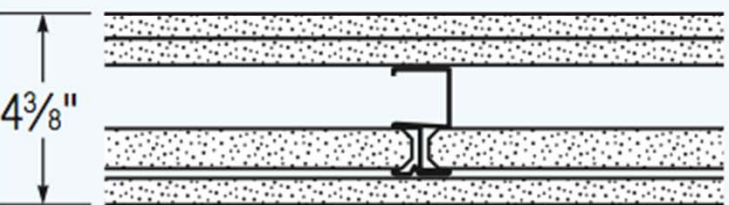

- 5/8" SHEETROCK FIRECODE C Core gypsum panels, face layer joints finished
- 2-1/2" USG C-H Studs 25 gauge 24" o.c.
- 1" SHEETROCK gypsum liner panels
- 5/8" SHEETROCK FIRECODE C Core gypsum panels, joints finished

**UL Des U415,  
System H**

**Could install wood bearing wall on each side of 3 hour wall**

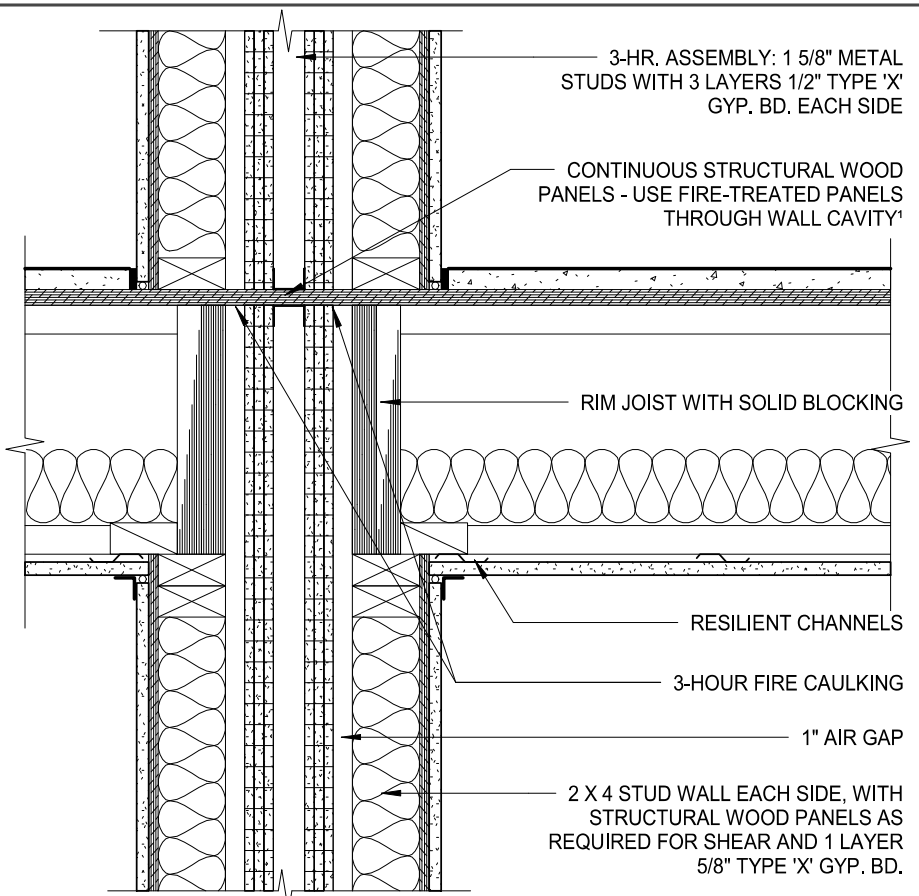

<sup>1</sup>CONSULT LOCAL JURISDICTION HAVING AUTHORITY FOR ACCEPTANCE OF FIRE-TREATED WOOD PANELS RUNNING THROUGH 3-HOUR ASSEMBLY IN THIS APPLICATION.

## 3-HOUR FIRE WALL AT FLOOR/CEILING

I-JOIST FRAMING WITH WOOD PANEL DIAPHRAGM RUNNING THROUGH FIRE WALL

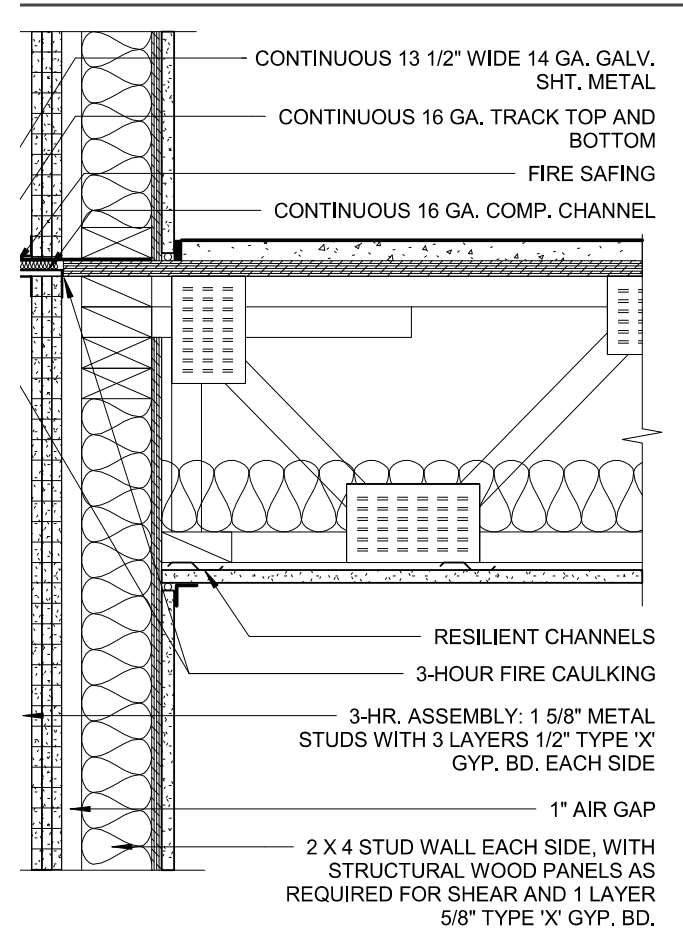

## L AT FLOOR/CEILING

WOOD PANEL DIAPHRAGM RUNNING THROUGH FIRE WALL

# Fire Walls – Seismic Diaphragm Continuity

---



## SEAOSC LIGHT-FRAMING CONSTRUCTION COMMITTEE STRUCTURAL ENGINEERS ASSOCIATION OF SOUTHERN CALIFORNIA SEISMOLOGY OPINION

---

**DATE:** March 21, 2008

### **Continuity of Plywood Diaphragm Sheathing in 2 hr and 3hr Fire Walls:**

**Opinion:** The continuity of plywood diaphragm sheathing should be maintained across the air gap commonly encountered in double stud Firewalls of 2 or 3 hour construction. The intent is to ensure that structural continuity is not significantly reduced in the roof and floor diaphragms.

---

### **Commentary:**

This opinion is prepared to address the issue of diaphragm continuity as it relates to recent changes in 2007 CBC and 2006 IBC model code. Specifically the outgoing UBC provisions for Area-Separation walls have more or less been replaced by the Fire wall provisions of the IBC. Such walls are encountered in light-frame multifamily or mixed-use construction and are often constructed as a double studwall when occurring at partywall locations. The double stud walls are typically separated by an airspace of a one to four inches.

The IBC has introduced language [IBC 705.4] that states fire walls must have “sufficient structural stability” under fire conditions to allow collapse of either side. Previous commentary to the UBC topic of Area Separation



# Fire Walls – Seismic Diaphragm Continuity

---

## New 2018 IBC Provisions Allow Floor Sheathing Through Firewall under Certain Conditions

### **706.2 Structural stability.**

*Fire walls* shall be designed and constructed to allow collapse of the structure on either side without collapse of the wall under fire conditions. *Fire walls* designed and constructed in accordance with NFPA 221 shall be deemed to comply with this section.

**Exception:** In Seismic Design Categories D through F, where double *fire walls* are used in accordance with NFPA 221, floor and roof sheathing not exceeding  $\frac{3}{4}$  inch (19.05 mm) thickness shall be permitted to be continuous through the wall assemblies of light frame construction.

---

# Fire Walls - Openings

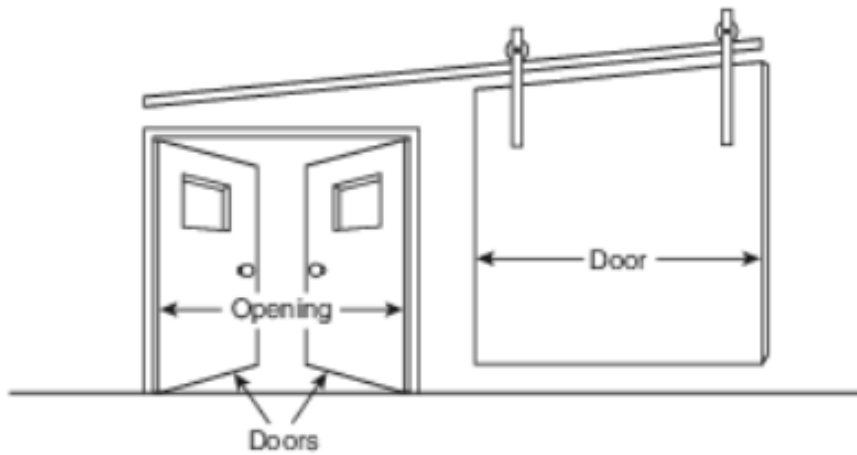

**FIGURE A.5.8.3(a) Swinging Door and Sliding Door Configuration for Egress Purposes in an HC Fire Wall.**

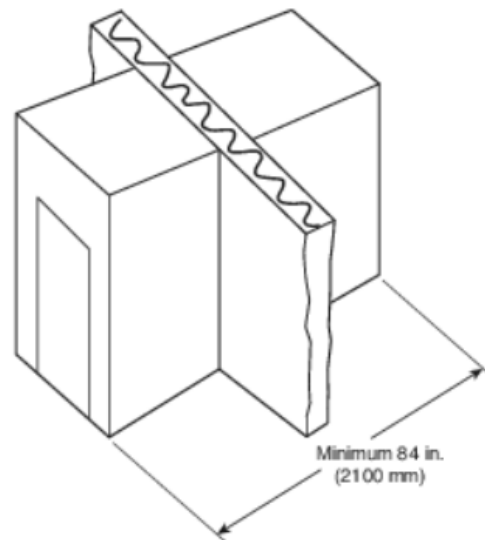

**FIGURE A.5.8.3(b) Vestibule Arrangement for Egress Purposes in an HC Fire Wall.**

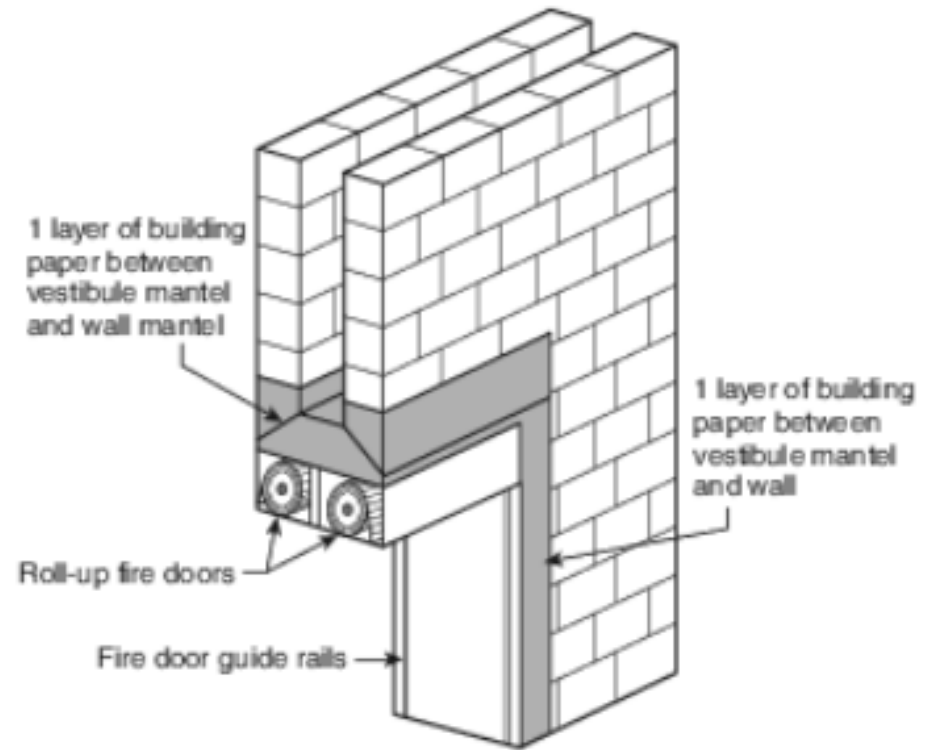

**FIGURE A.5.8.4 Double Doors on a Freestanding Vestibule.**



# Fire Barriers – IBC 707

---

Commonly used in:

- Shaft enclosures
- Interior exit stairway
- Exit stairway enclosures
- Exit passageways
- Incidental uses
- Separated occupancies
- Fire Areas

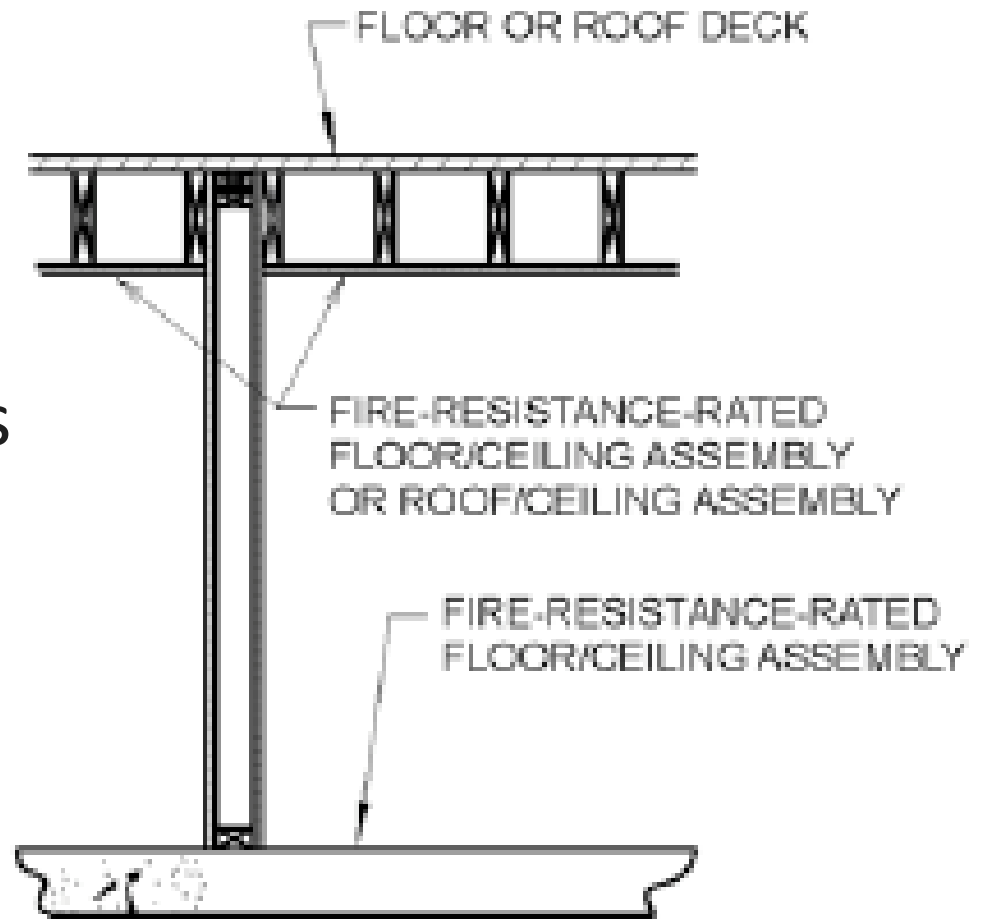

Fire Barrier Example

# Fire Barriers – IBC 707

---

## Fire Barriers:

- May be constructed with any materials permitted by the construction type
- Fire Resistance Ratings:
  - Shaft Enclosures: IBC 713.4
    - 2 Hr when connecting 4 stories or more, 1 hr if less
  - Separated Occupancies: IBC Table 508.4
  - Fire Areas: IBC Table 707.3.10

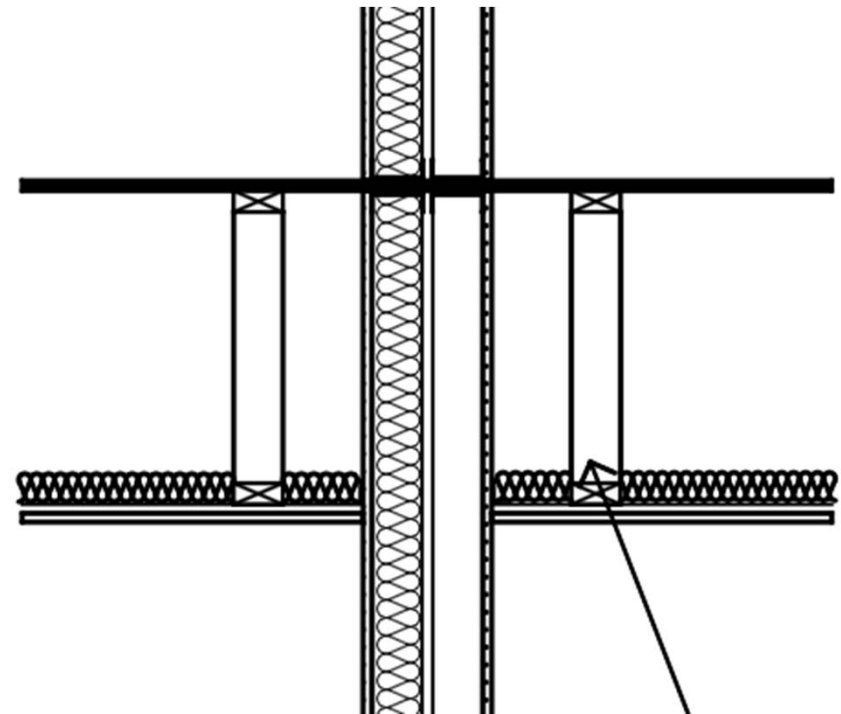

# Fire Barriers – IBC 707

---

707.5: Continuity: Fire barriers shall extend from the top of the foundation or floor/ceiling assembly below to the underside of the floor or roof sheathing, slab or deck above and shall be securely attached thereto. Such fire barriers shall be continuous through concealed space, such as the space above a suspended ceiling

707.5.1 Supporting Construction: The supporting construction for a fire barrier shall be protected to afford the required fire-resistance rating of the fire barrier supported. Hollow vertical spaces within a fire barrier shall be fireblocked in accordance with Section 718.2 at every floor level.

Other requirements for openings, penetrations, joints

# Fire Barriers – IBC 707

---



Common Detailing Method: Fire Barrier & membrane extend to underside of floor deck above

# Fire Partitions – IBC 708

---

Commonly used to separate:

- Dwelling or sleeping units in same bldg.
- Tenant spaces in malls
- Corridor walls

Minimum 1 hr rating  
except:

- Some corridors
- Separate dwelling units in VB and IIB

FIRE-RESISTANCE-RATED  
FLOOR ASSEMBLY

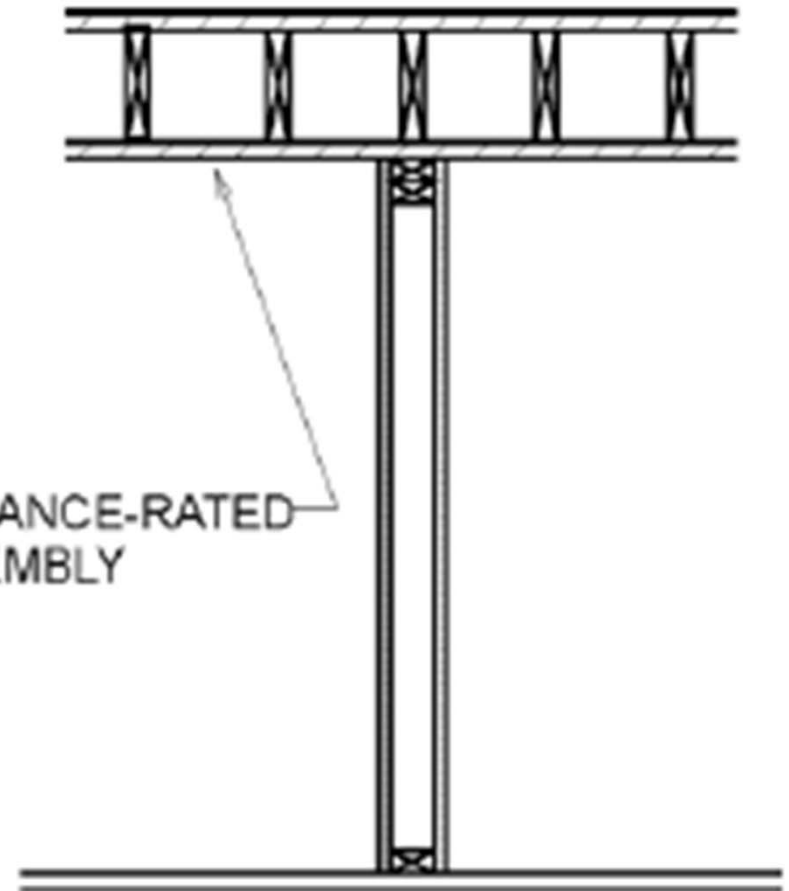

Fire Partition Example

# Fire Partitions – IBC 708

---

## Fire Partitions:

- May be constructed with any materials permitted by the construction type
- 708.3 Fire Resistance Ratings:
  - Fire partitions shall have a *fire-resistance rating* of not less than 1 hour.

## Exceptions:

1. Corridor walls permitted to have a  $1/2$  hour fire-resistance rating by Table 1020.1
2. Dwelling unit and sleeping unit separations in buildings of Type IIB, IIIB and VB construction shall have fire-resistance ratings of not less than  $1/2$  hour in buildings equipped throughout with an automatic sprinkler system in accordance with Section 903.3.1.1.



# Fire Partitions – IBC 708

---

## 708.4 Continuity.

Fire partitions shall extend from the top of the foundation or floor/ceiling assembly below to the underside of the floor or roof sheathing, slab or deck above or to the fire-resistance-rated floor/ceiling or roof/ceiling assembly above, and shall be securely attached thereto. In combustible construction where the *fire partitions* are not required to be continuous to the sheathing, deck or slab, the space between the ceiling and the sheathing, deck or slab above shall be fireblocked or draftstopped in accordance with Section 718.2 and 718.3 at the partition line.

The supporting construction shall be supported to afford the required fire-resistance rating of the wall supported, except for...walls separating dwelling units, walls separating sleeping units, and corridor walls, in buildings of Type IIB, IIIB and VB construction.

# Fire Partitions – IBC 708

---



Common Detailing Method: Fire Partition & membrane stop at underside of rated floor/ceiling with fireblocking/draftstopping if required



# Corridors – Fire Resistance Ratings

Check requirements of IBC Tables 601 and 1020.1 for Corridor Wall and Floor/Ceiling Fire-Resistance Ratings

**TABLE 1018.1 CORRIDOR FIRE-RESISTANCE RATING**

OCCUPANCY	OCCUPANT LOAD SERVED BY CORRIDOR	REQUIRED FIRE-RESISTANCE RATING (hours)	
		Without sprinkler system	With sprinkler system <sup>c</sup>
H-1, H-2, H-3	All	Not Permitted	1
H-4, H-5	Greater than 30	Not Permitted	1
A, B, E, F, M, S, U	Greater than 30	1	0
R	Greater than 10	Not Permitted	0.5
I-2 <sup>a</sup> , I-4	All	Not Permitted	0
I-1, I-3	All	Not Permitted	1 <sup>b</sup>

**TABLE 601 FIRE-RESISTANCE RATING REQUIREMENTS FOR BUILDING ELEMENTS (HOURS)**

BUILDING ELEMENT	TYPE I		TYPE II		TYPE III		TYPE IV	TYPE V	
	A	B	A <sup>d</sup>	B	A <sup>d</sup>	B	HT	A <sup>d</sup>	B
Primary structural frame <sup>g</sup> (see <a href="#">Section 202</a> )	3 <sup>a</sup>	2 <sup>a</sup>	1	0	1	0	HT	1	0
Bearing walls									
Exterior <sup>f, g</sup>	3	2	1	0	2	2	2	1	0
Interior	3 <sup>a</sup>	2 <sup>a</sup>	1	0	1	0	1/HT	1	0
Nonbearing walls and partitions	See Table 602								
Exterior	See Table 602								
Interior <sup>e</sup>	0	0	0	0	0	0	See <a href="#">Section 602.4.6</a>	0	0
Floor construction and associated secondary member (see <a href="#">Section 202</a> )	2	2	1	0	1	0	HT	1	0

# Corridors – Fire Resistance Ratings



# Corridor Walls

---

**IBC 1020.1:** Corridor walls required to be fire-resistance rated shall comply with Section 708 for fire partitions.

## **708.3 Fire-resistance rating.**

Fire partitions shall have a fire-resistance rating of not less than 1 hour.

Exception: Corridor walls permitted to have a  $\frac{1}{2}$  hour fire-resistance rating by Table 1018.1 (applies to R occupancies with sprinkler systems)

# Corridor Walls

---

## 708.4 Continuity.

Fire partitions shall extend from the top of the foundation or floor/ceiling assembly below to the underside of the floor or roof sheathing, slab or deck above or to the fire-resistance-rated floor/ceiling or roof/ceiling assembly above, and shall be securely attached thereto.

### Exceptions:

2. Where the room-side fire-resistance-rated membrane of the *corridor* is carried through to the underside of the floor or roof sheathing, deck or slab of a fire-resistance-rated floor or roof above, the ceiling of the *corridor* shall be permitted to be protected by the use of ceiling materials as required for a 1-hour fire-resistance-rated floor or roof system.
3. Where the *corridor* ceiling is constructed as required for the *corridor* walls, the walls shall be permitted to terminate at the upper membrane of such ceiling assembly.

# Corridor Walls – 708.4 Exception 2

Figure 708.4(2)(B)  
FIRE PARTITION CONTINUITY

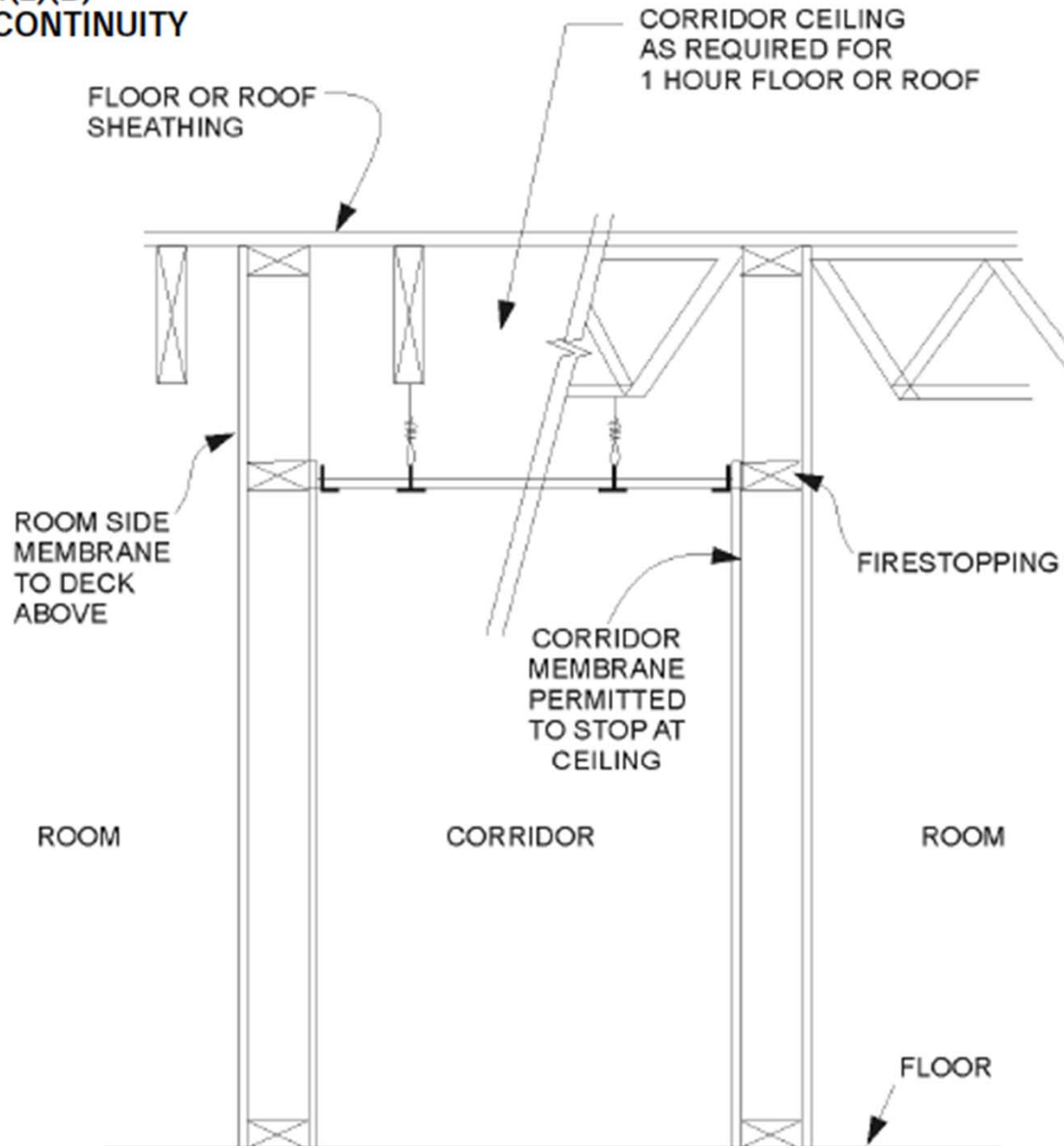



# Corridor Walls – 708.4 Exception 3

---

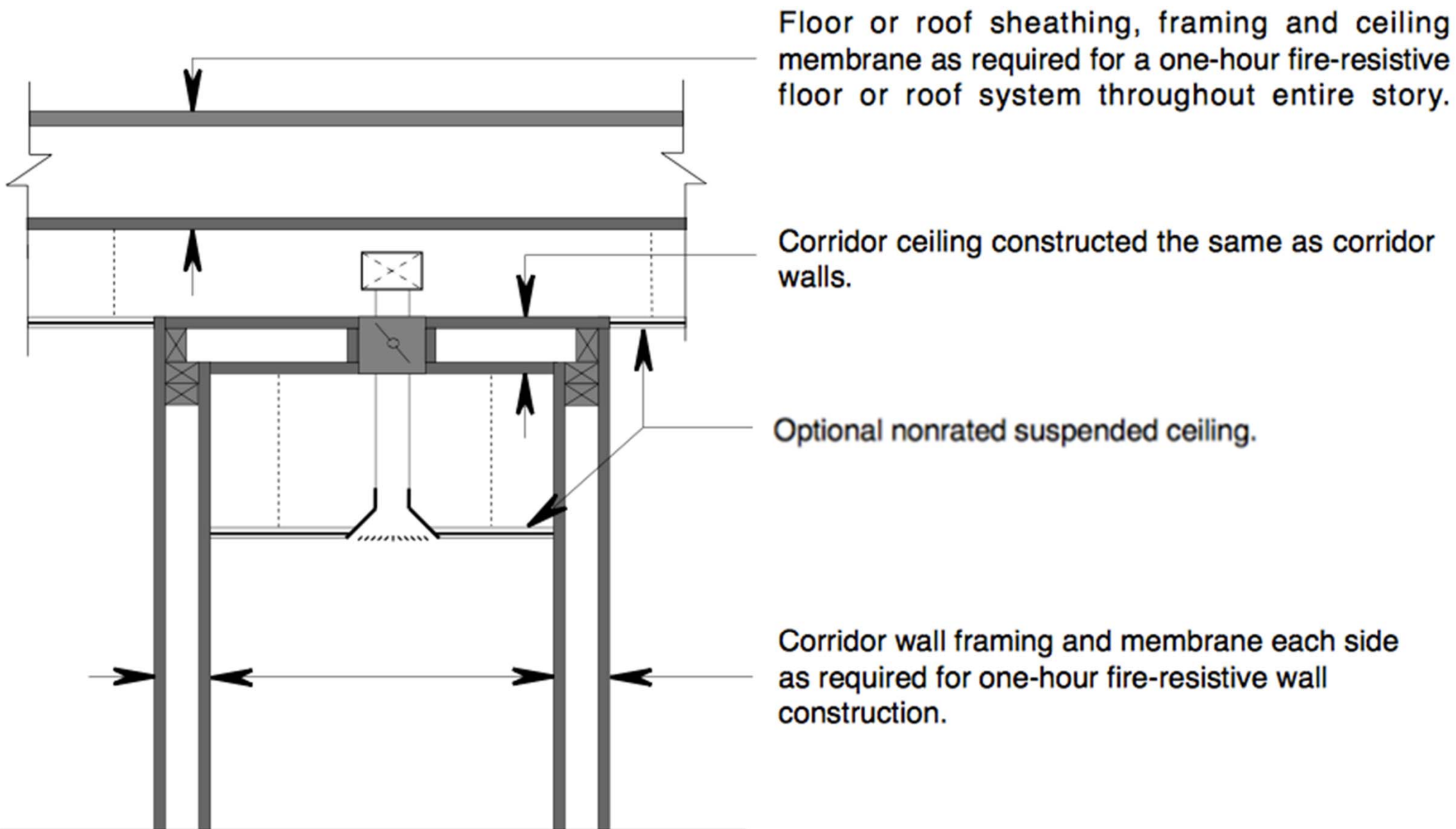

# Corridors - 1hr Floor

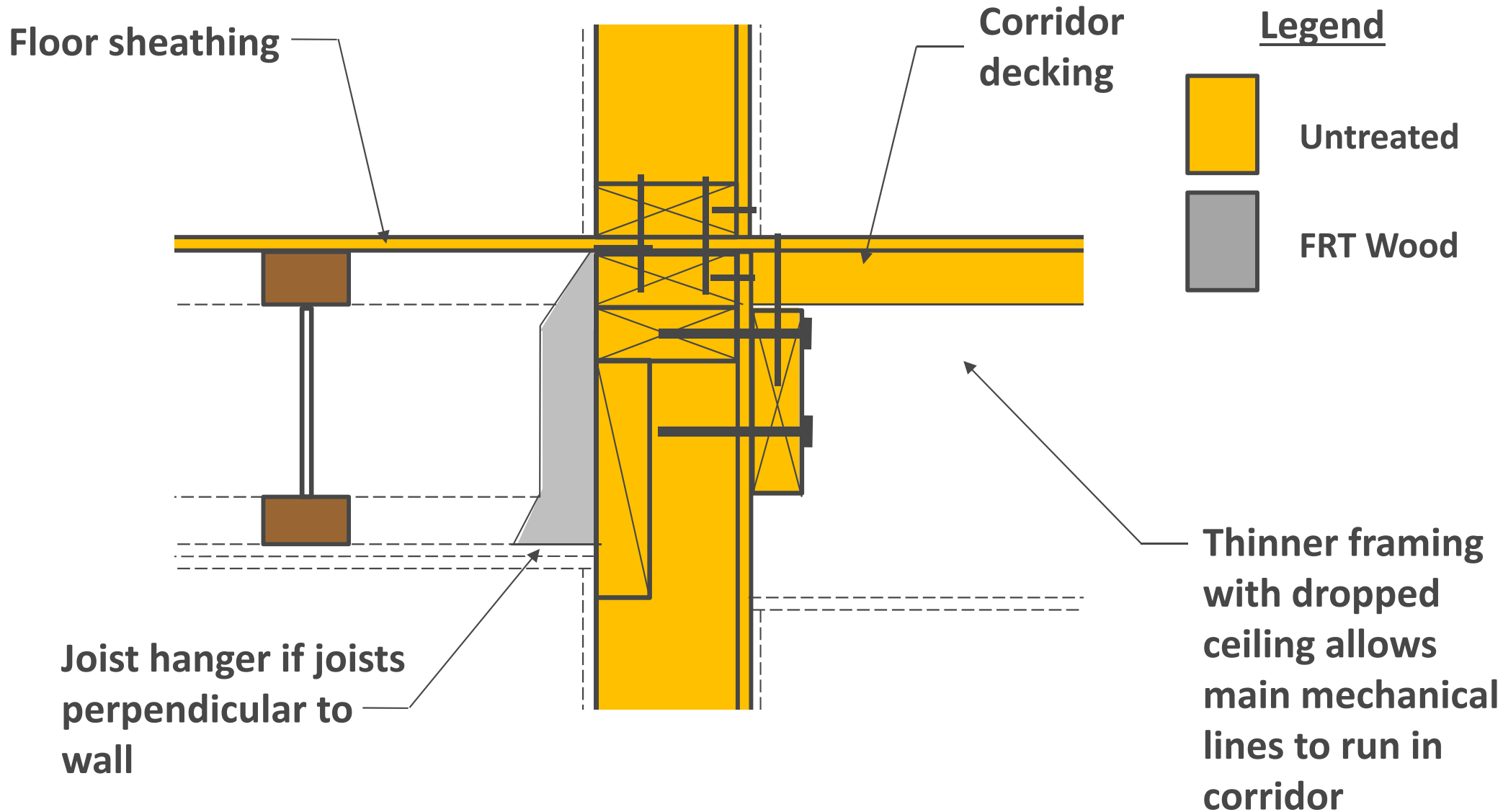

# Outline

---

- Review of Fire Resistance Methods
- Interior Fire Rated Wall Assemblies
  - Fire Walls
  - Fire Barriers
  - Fire Partitions
- Horizontal Assemblies



# Horizontal Assemblies

---

- A floor or roof assembly required to have a fire resistance rating such as for occupancy separations and fire area separations
- May be constructed with any materials permitted by the construction type
- Occupancy separation: Fire resistance ratings per IBC Table 508.4
- Required to be continuous without vertical openings except as permitted in IBC 712
- Supporting construction required to have same fire-resistance rating as the fire barrier being supported (with exceptions per 711.4)
- Other requirements for openings, penetrations, joints



# Fire Resistance Ratings – 711.2.4

---

Fire resistance shall not be less than that required for:

- Separating mixed occupancies – 508.4
  - Up to 1hr for sprinklered for other than I and H occupancy
  - Up to 2hr for non-sprinklered for other than I and H occupancy
- Separating fire areas – 707.3.10
  - 2hr for most occupancies for other than H and F-1
  - 3hr for S1/ 1hr for U
- Dwelling units – not less than 1hr
  - Except for IIB, IIIB, VB with NFPA 13 sprinklers is ½ hr
- Separating smoke compartments – 709
- Separating incidental uses – 509

# Fire Resistance – Insulation Effects

---

*"The addition of up to 16-3/4 inches of 0.5 pcf glass fiber insulation (R-40), either batt or loose-fill, to any 1- or 2-hour fire resistance rated floor-ceiling or roof-ceiling system having a cavity deep enough to accept the insulation is permitted provided that one additional layer of either 1/2 inch or 5/8 inch type X gypsum board is applied to the ceiling. The additional layer of gypsum board shall be applied as described for the face layer of the tested system except that the fastener length shall be increased by not less than the thickness of the additional layer of gypsum board."*

-Section 1.12 Gypsum Association's Fire Resistance Design Manual

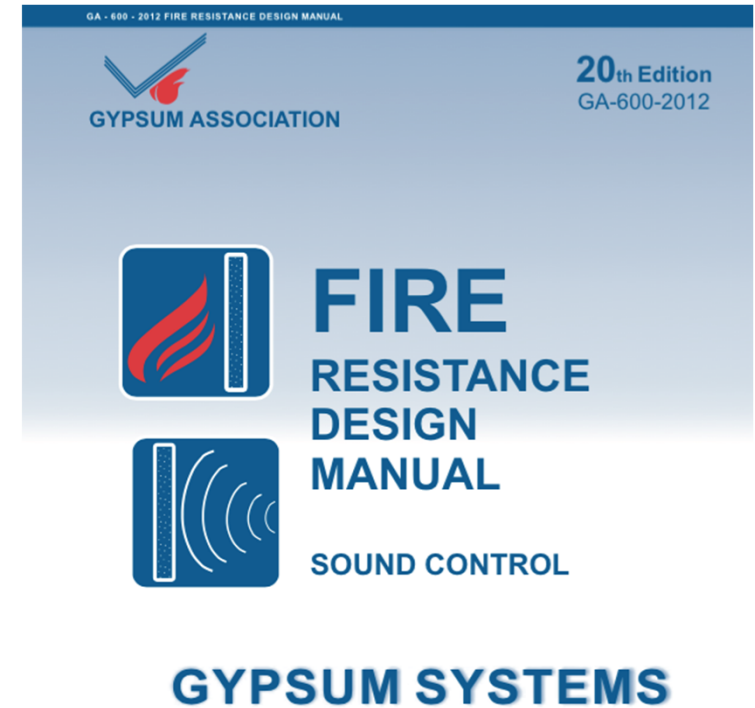

# Trusses

*"Specified floor-ceiling and roof-ceiling framing sizes or truss dimensions are minimums. Greater joist or truss sizes (depths) shall be permitted to be used in metal- or wood-framed systems."*

-Section 1.17 Gypsum Association's Fire Resistance Design Manual

*"Thus, larger and deeper trusses can be used under the auspices of the same design number. This approach has often been applied to roof truss applications since roof trusses are usually much deeper than the tested assemblies".*

- WTCA's Metal Plate Connected Wood Truss Handbook

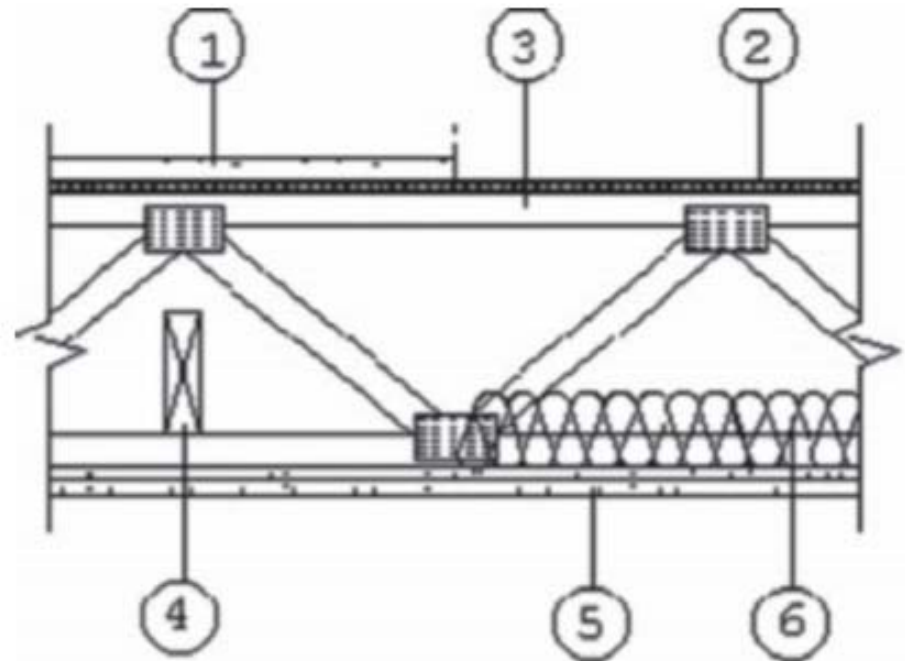

## TSC/FCA 60-10

1. Topping (optional)
2. Flooring - min  $\frac{3}{4}$ " plywood
3. Truss – min depth 10", spaced at 24"oc
4. Bridging/Strongback
5. 2 layers  $\frac{1}{2}$ " Type X Gyp
6. Insulation (optional) – supported by metal furring or 1x3 wood furring strips at 16" oc. "Equivalent methods that retain insulation above joist bottom flange are acceptable"

# Shallow Floor Depths

---

**UL L502**  
**GA FC5104**

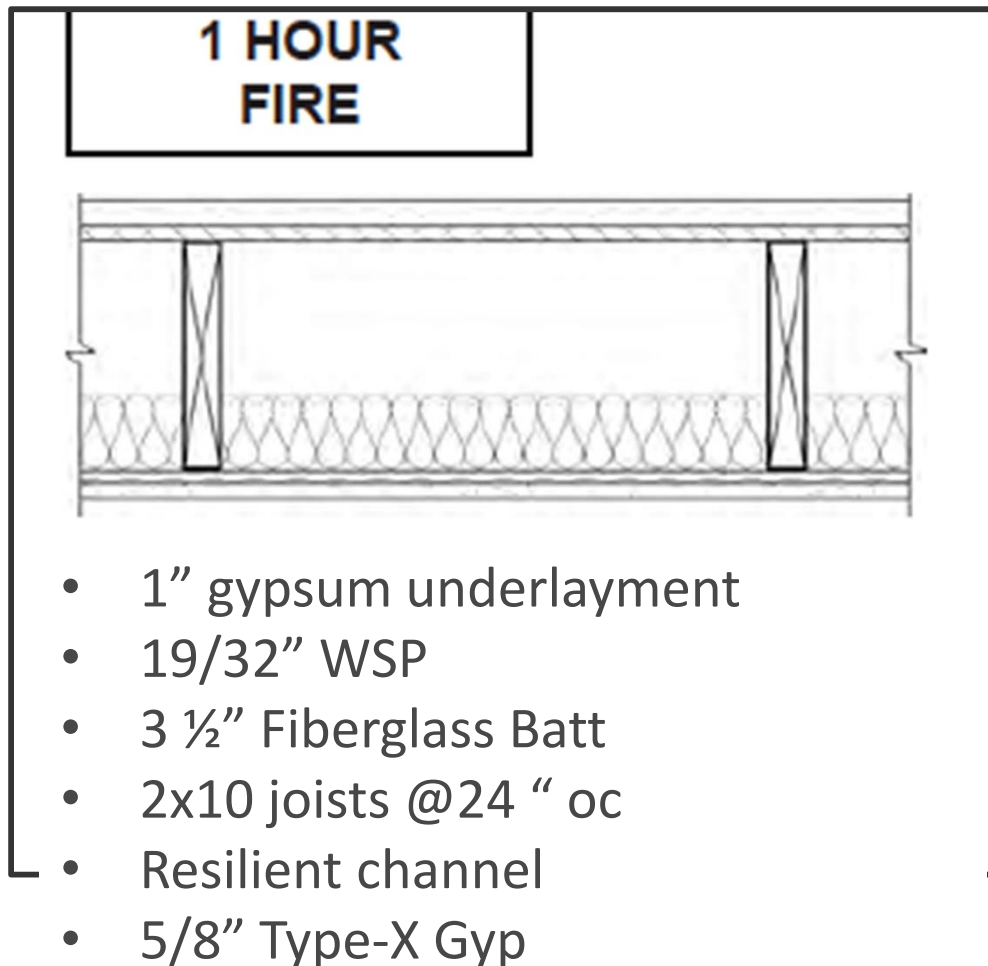

Common issues with UL approved assemblies:

- Shallow Floor depth-
  - Use prescriptive assemblies - IBC 721.1(2) assembly 14-1.1
  - Or use the CAM method in IBC 722
- Use of Structural Composite Lumber
  - Manufacturer's ESR shows equivalent fire performance to solid saen

# Assembly Intersection

Can a wall interrupt the ceiling gypsum of a rated horizontal assembly?

Yes!

- **IBC 2012** 714.4.1.2, Except. 7: Permitted if wall is rated to match horizontal assembly
- **IBC 2015** 714.4.2, Except. 7: Permitted if wall is covered with type X gypsum each side

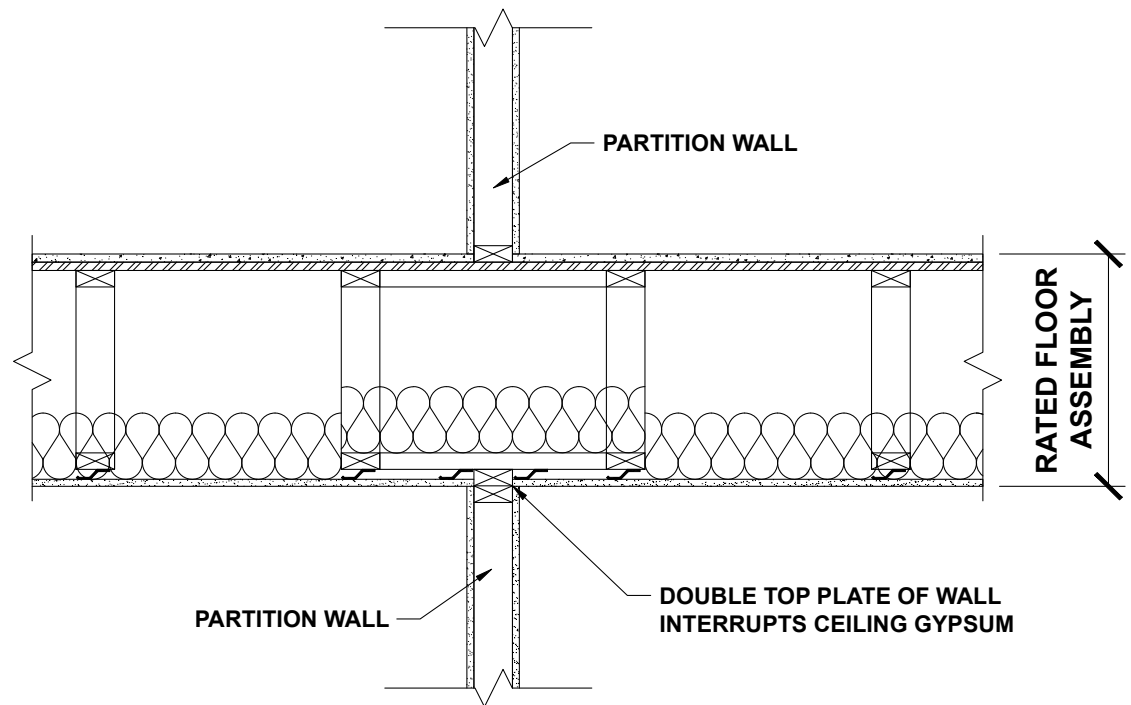

**INTERIOR WALL TO FLOOR INTERSECTION**

# Joint vs. Assembly Intersection

## SECTION 202 DEFINITIONS

**Joint.** *The opening in or between adjacent assemblies that is created due to building tolerances, or is designed to allow independent movement of the building in any plane caused by thermal, seismic, wind or any other loading.*

FIGURE 2:

IBC Commentary Figure 715.1 –  
Examples of Joint Locations

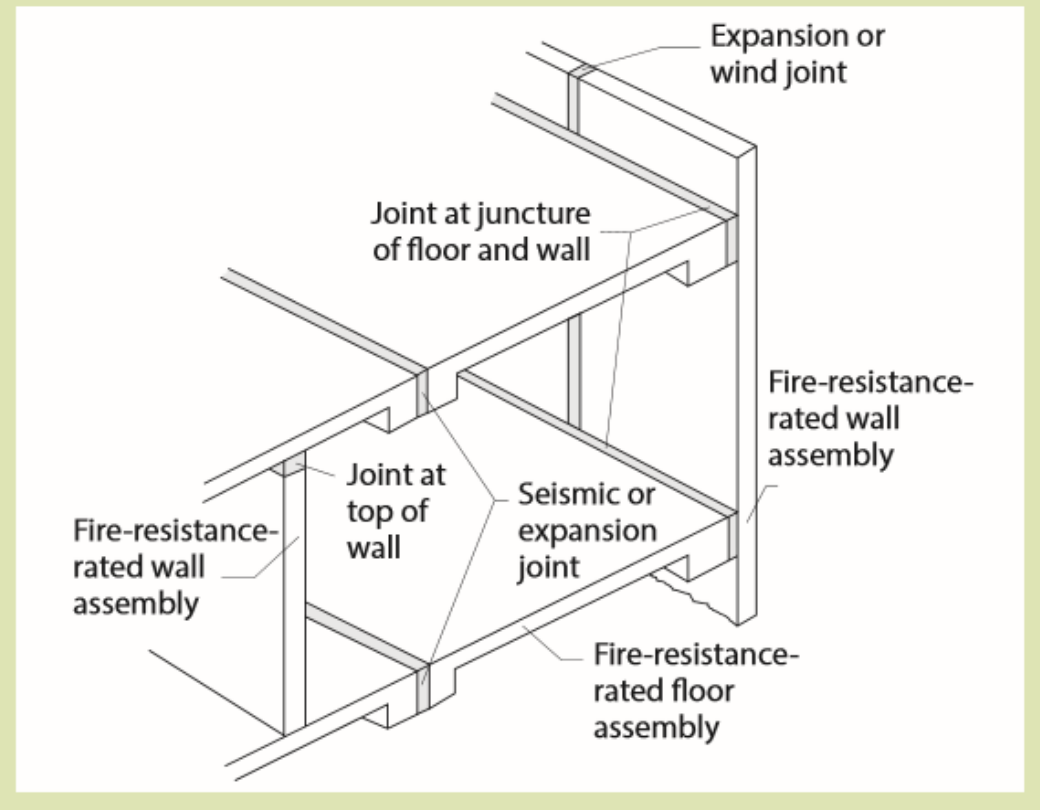



# Joints

---

Truss manufactures often recommend a gap to accommodate deflection between the bottom chord and interior non-bearing walls. How is that detailed?

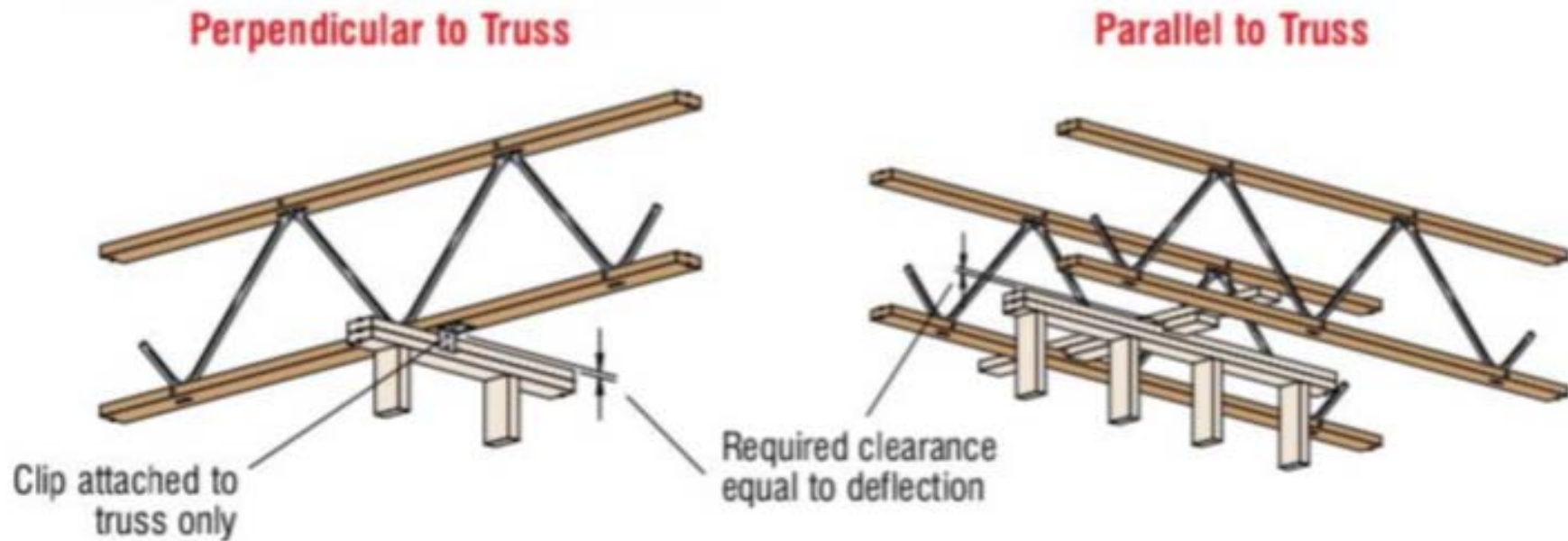



# Joints – IBC 715

## Exceptions to rated joints:

- Walls that allow unprotected openings
- Control joints not exceeding .625” and tested in E119 assembly

## Joint Assemblies available through UL Directory

- not easily searchable
- HWS or HWD
- very few wood assemblies
- joint manufacturer may supply engineering judgement



### Joint Systems (XHBN & XHBO)

A joint system is a specific construction consisting of adjacent wall and/or floor assemblies and the materials designed to prevent the spread of fire through a linear opening between the wall and/or floor assemblies.

#### Numbering System

The systems are identified in this category by an alpha-alpha-numeric identification system. The alpha components identify the type of joint system and whether the joint system has movement capabilities. The numeric components identify the nominal joint width. In the case of head of wall joint systems, the width of the joint does not include the voids created under the crests of metal deck floor or roof systems.

The first two alpha characters identify the type of joint system as follows:

Alpha Characters	Description of Joint System
FF	Floor-to-Floor
WW	Wall-to-Wall
FW	Floor-to-Wall
HW	Head-of-Wall
BW	Bottom-of-Wall
CG	Wall-to-Wall Joints Intended for use as Corner Guards
CJ	Continuity Head-of-Wall

The third alpha character is either S or D. The S signifies joint systems that do not have movement capabilities. This D signifies joint systems that do have movement capabilities.

The numeric component uses sequential numbers to identify the nominal width of the joint systems. The significance of the number used is:

No. Range	Nominal Joint Width
0000 - 0999	Less than or equal to 2 in.
1000 - 1999	Greater than 2 in. and less than or equal to 6 in.
2000 - 2999	Greater than 6 in. and less than or equal to 12 in.
3000 - 3999	Greater than 12 in. and less than or equal to 24 in.
4000 - 4999	Greater than 24 in.

# Joint Systems



**System No. HW-S-0088**  
**XHBN.HW-S-0088**  
**Joint Systems**

[Page Bottom](#)

### Design/System/Construction/Assembly Usage Disclaimer

- Authorities Having Jurisdiction should be consulted in all cases as to the particular requirements covering the installation and use of UL Certified products, equipment, system, devices, and materials.
- Authorities Having Jurisdiction should be consulted before construction.
- Fire resistance assemblies and products are developed by the design submitter and have been investigated by UL for compliance with applicable requirements. The published information cannot always address every construction nuance encountered in the field.
- When field issues arise, it is recommended the first contact for assistance be the technical service manufacturer noted for the design. Users of fire resistance assemblies are advised to consult the product category and each group of assemblies. The Guide Information includes specifics concerning methods of construction.
- Only products which bear UL's Mark are considered Certified.

### XHBN - Joint Systems

[See General Information for Joint Systems](#)

**System No. HW-S-0088**

December 05, 2008

**Assembly Rating – 1 Hr**

**Joint Width – 1/2 In. (13 mm) Max**

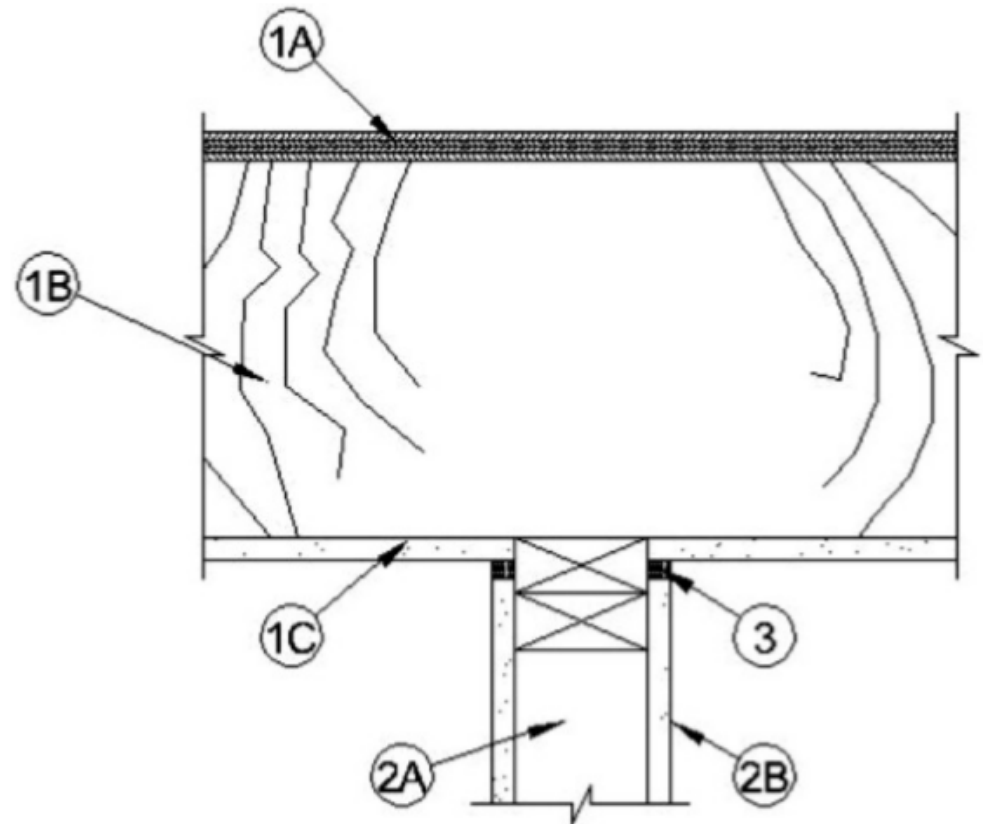

# Individual Encasement - Column

---



<http://www.woodworks.org/ask-an-expert/>

# Individual Encasement - Column

**TABLE 601  
FIRE-RESISTANCE RATING REQUIREMENTS FOR BUILDING ELEMENTS (HOURS)**

BUILDING ELEMENT	TYPE I		TYPE II		TYPE III		TYPE IV	TYPE V	
	A	B	A	B	A	B	HT	A	B
Primary structural frame <sup>f</sup> (see Section 202)					1	0		1	0
Bearing walls									
Exterior <sup>e,f</sup>					2	2		1	0
Interior					1	0		1	0
Nonbearing walls and partitions	See Table 602								
Exterior									
Nonbearing walls and partitions					0	0		0	0
Interior <sup>d</sup>									
Floor construction and associated secondary members (see Section 202)	2	2	1	0	1	0	HT	1	0
Roof construction and associated secondary members (see Section 202)	1½ <sup>b</sup>	1 <sup>b,c</sup>	1 <sup>b,c</sup>	0 <sup>c</sup>	1 <sup>b,c</sup>	0	HT	1 <sup>b,c</sup>	0

**BEARING WALL STRUCTURE.** A building or other structure in which vertical loads from floors and roofs are primarily supported by walls.

**FRAME STRUCTURE.** A building or other structure in which vertical loads from floors and roofs are primarily supported by columns.

# Light Frame Bearing Walls -IBC 704.4.1

## **704.4 Protection of secondary members.**

Secondary members that are required to have a fire resistance rating shall be protected by individual encasement protection, by the membrane or ceiling of a horizontal assembly in accordance with 711, or by a combination of both.

## **704.4.1 Light Frame Construction.**

King Studs and boundary elements that are integral elements in load-bearing walls of light-frame construction shall be permitted to have required fire-resistance ratings provided by the membrane protection provided for the load-bearing wall.

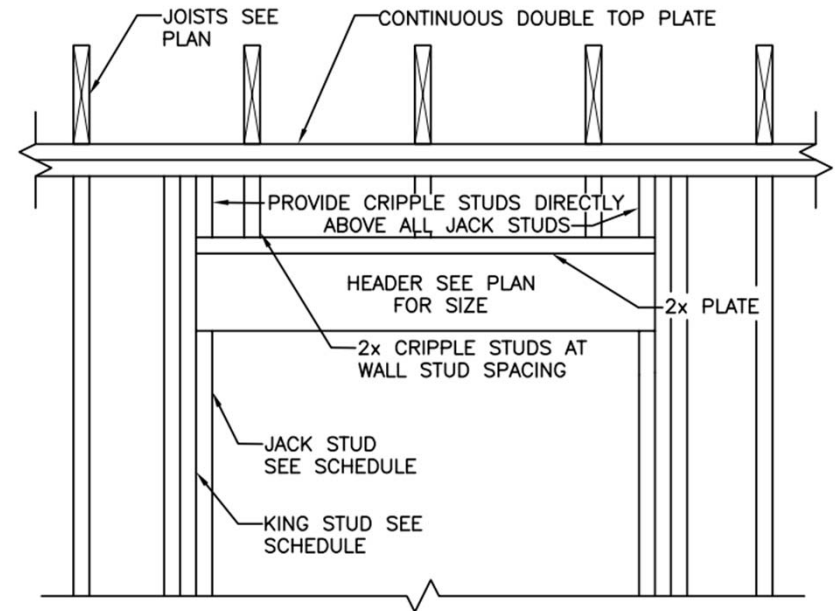

Typ. Bearing Wall Opening Framing



# Light Frame Bearing Walls – 2018 IBC

---

## 2018 IBC -SECTION 704

### FIRE RESISTANCE RATING OF STRUCTURAL MEMBERS

#### **704.2 Column protection.**

*Where columns are required to have protection to achieve a fire-resistance rating, the entire column shall be provided individual encasement protection by protecting it on all sides for the full column length, including connections to other structural members, with materials having the required fire resistance rating. Where the column extends through a ceiling, the encasement protection shall be continuous from the top of the foundation or floor/ceiling assembly below through the ceiling space to the top of the column.*

**Exception:** Columns that meet the limitations of Section 704.4.1

#### **704.4.1 Light-frame construction.**

*Studs, columns and boundary elements that are integral elements in walls of light-frame construction and are located entirely between the top and bottom plates or tracks shall be permitted to have require fire-resistance ratings provided by the membrane protection provided for the wall*

# Column Fire Resistance

## PROTECTION OF WOOD COLUMNS AND BEAMS

Fire-resistance ratings for exposed structural wood elements are typically calculated using either the T.T. Lie method or the National Design Specifications (NDS) Method. There is no widely accepted method for calculating the fire-resistance rating of an individual structural wood column or beam protected with gypsum board applied to its exposed surfaces. In general, fire resistance of the unprotected column or beam is calculated using one of the above methods and the rating of the protected column or beam is estimated by adding 30 min. for a single layer of  $\frac{5}{8}$  inch (15.9 mm) Type X gypsum board or 60 min. for a double layer of  $\frac{5}{8}$  inch (15.9 mm) Type X gypsum board.

A discussion of the calculation methods is contained in the following documents:

1. *Calculating the Fire Resistance of Exposed Wood Members*, AWC 10, published by the American Wood Council.
2. *Analytical Methods for Determining Fire Resistance of Timber Members* published by the U.S. Department of Agriculture, Forest Products Laboratory.
3. *Calculation of Fire Resistance of Glued Laminated Timbers*, AITC Technical Note 7, published by American Institute of Timber Construction.

- Gypsum Association Fire Resistance Design Manual

## 2015 IBC Code and Commentary on 704.2

*“Columns that provide inherent fire resistance, without encasement, such as heavy timber, are considered as not requiring protection and do not need to comply with this section.”*

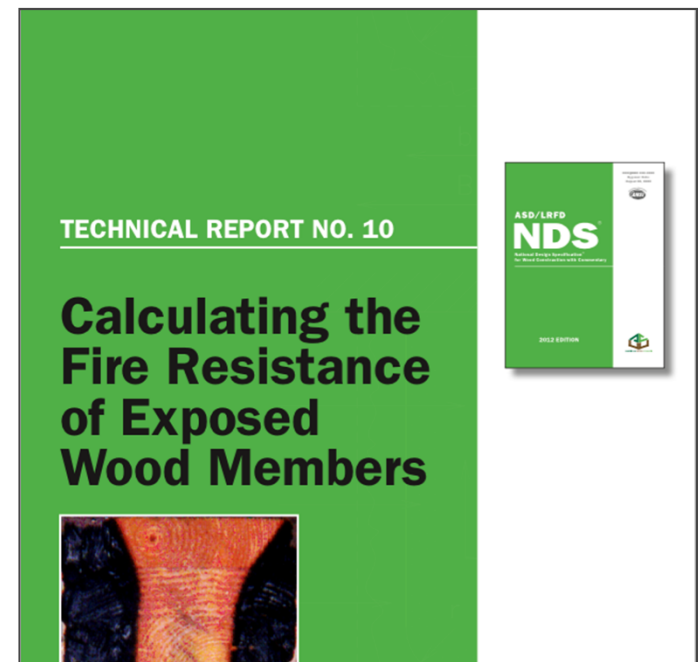



# Column vs. Boundary Elements

---

- If posts/stud packs in a wall lie between plates:
  - Considered “secondary members” by not having direct connection to the columns and covered by exceptions
  - Fire rating can be provided by membrane
  - Per Table 601, need to be 2hr rated for IIIA and 1 hr for VA
- If posts/stud packs break the top and/or bottom plate:
  - May be considered primary frame and be considered a “column” member
  - Need to be individually encased
  - Per Table 601, need to be rated to 1hr for IIIA and VA construction
  - Protection can be provided by charring effects
  - Protection of connections needs to be considered

# Beam Encasement

TABLE 601  
FIRE-RESISTANCE RATING REQUIREMENTS FOR BUILDING ELEMENTS (HOURS)

BUILDING ELEMENT	TYPE I		TYPE II		TYPE III		TYPE IV	TYPE V	
	A	B	A	B	A	B	HT	A	B
Primary structural frame <sup>f</sup> (see Section 202)					1	0		1	0
Bearing walls									
Exterior <sup>e,f</sup>					2	2		1	0
Interior					1	0		1	0
Nonbearing walls and partitions	See Table 602								
Exterior									
Interior <sup>d</sup>					0	0		0	0
Floor construction and associated secondary members (see Section 202)	2	2	1	0	1	0	HT	1	0
Roof construction and associated secondary members (see Section 202)	1½ <sup>b</sup>	1 <sup>b,c</sup>	1 <sup>b,c</sup>	0 <sup>c</sup>	1 <sup>b,c</sup>	0	HT	1 <sup>b,c</sup>	0

**BEARING WALL STRUCTURE.** A building or other structure in which vertical loads from floors and roofs are primarily supported by walls.

**FRAME STRUCTURE.** A building or other structure in which vertical loads from floors and roofs are primarily supported by columns.

# Beam Encasement

## **704.3 Protection of the primary structural frame other than columns.**

*Members of the primary structural frame other than columns that are required to have protection to achieve a fire-resistance rating and support more than two floors or one floor and roof, or support a load-bearing wall or a non load-bearing wall more than two stories high, shall be provided individual encasement protection by protecting them on all sides for the full length including connections to other structural members, with materials having the required fire-resistance rating.*

**Exception:** *Individual encasement protection on all sides shall be permitted on all exposed sides provided the extent of protection is in accordance with the required fire resistance rating as determined in Section 703.*

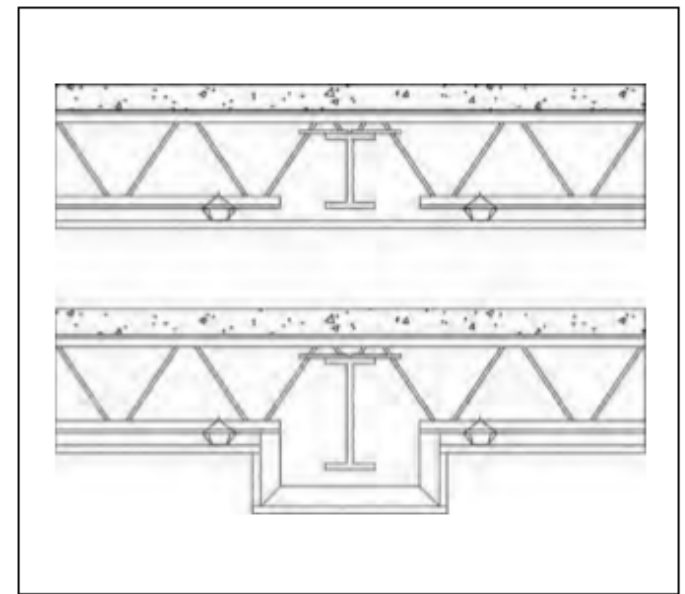

Figure 4  
Membrane Protected Steel Beam - Continuous

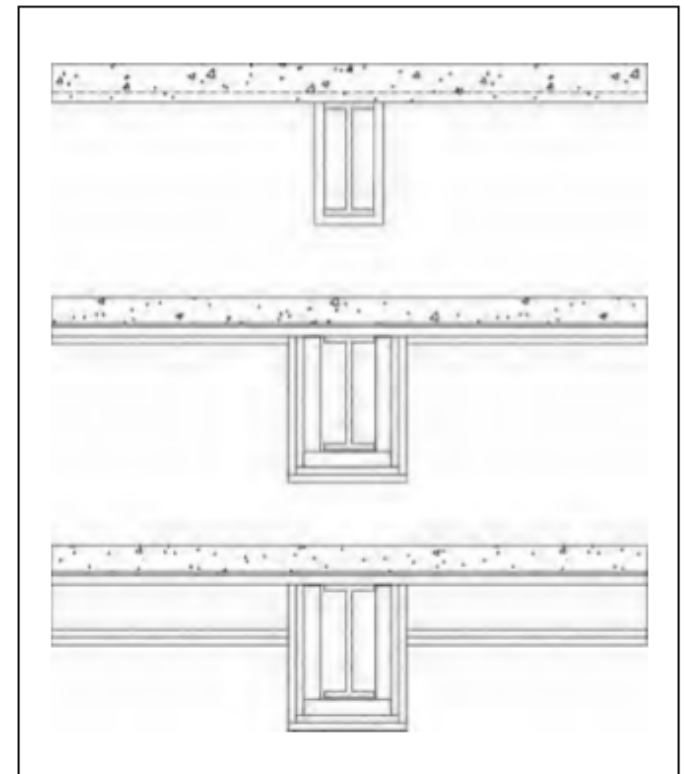

Figure 5  
Steel Beam - Individual Encasement Protection

# Exposed Framing Fire Resistance

## IBC 703.3 Alternate Methods for determining fire resistance

- Prescriptive designs per IBC 721.1
- **Calculations in accordance with IBC 722**
- Fire-resistance designs documented in sources
- Engineering analysis based on a comparison
- Alternate protection methods as allowed by 104.11

## IBC 722 Calculated Fire Resistance

“...The calculated *fire resistance* of exposed wood members and wood decking shall be permitted in accordance with **Chapter 16 of ANSI/AF&PA National Design Specification for Wood Construction (NDS)**.”

## NDS Chapter 16 Fire Design of Wood Members

Limited to calculating fire resistance up to 2 hours.

Char rate varies based on endurance required, product type and lamination thickness. Equations and tables provided.

TR10 and NDS commentary are helpful in implementing permitted calculations.

# Exposed Framing Fire Resistance

**Table 16.2.1A Effective Char Rates and Char Depths (for  $\beta_n = 1.5$  in./hr.)**

Required Fire Endurance (hr.)	Effective Char Rate, $\beta_{eff}$ (in./hr.)	Effective Char Depth, $a_{char}$ (in.)
1-Hour	1.8	1.8
1½-Hour	1.67	2.5
2-Hour	1.58	3.2

Source: 2015 NDS Chapter 16  
<http://awc.org/pdf/codes-standards/publications/nds/AWC-NDS2015-ViewOnly-1411.pdf>

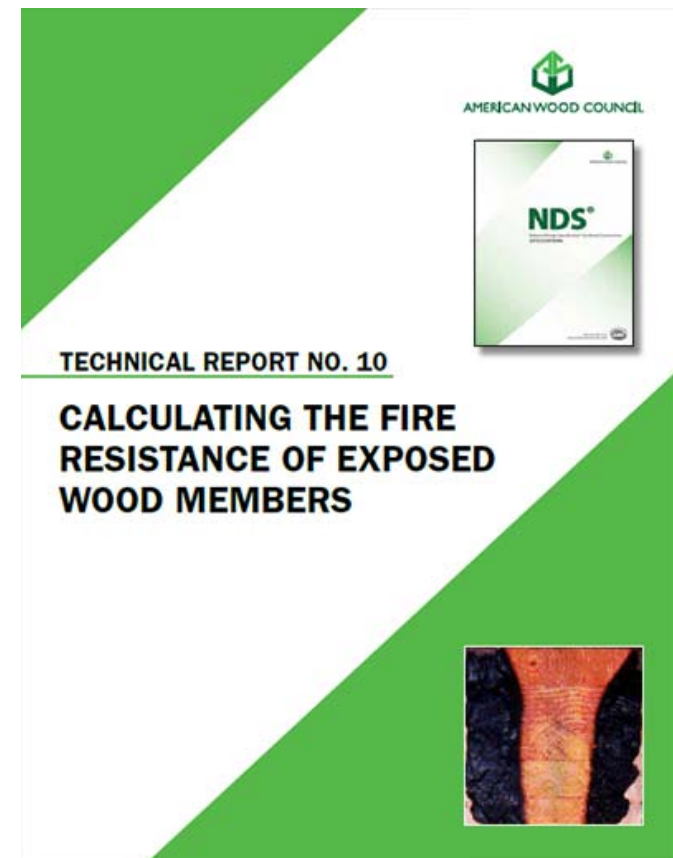

<http://awc.org/pdf/codes-standards/publications/tr/AWC-TR10-1510.pdf>



# Questions?

This concludes The  
American Institute of  
Architects Continuing  
Education Systems  
Course

**Ethan Martin, PE**

WoodWorks

[ethan@woodworks.org](mailto:ethan@woodworks.org)

toll free 855.USE.WOOD (873.9663)

cell 206.678.2086

