



**CONSUMER SERVICES TECHNICAL
EDUCATION GROUP PRESENTS**

KD-11



1998 WHIRLPOOL POWER CLEAN FILTER DISHWASHERS

**JOB AID
Part No. 4322451L**

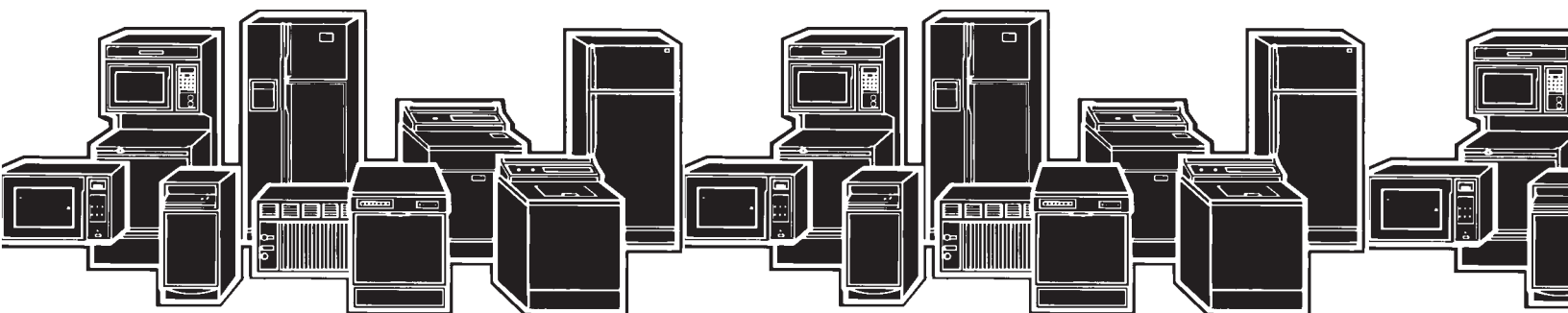

INTRODUCTION

This Job Aid, "1998 WHIRLPOOL POWER CLEAN FILTER DISHWASHERS," (Part No. 4322451) provides specific information for the installation, service and repair of 1998 Whirlpool Dishwashers equipped with Power Clean Filter pump and motor modules.

"1998 WHIRLPOOL POWER CLEAN FILTER DISHWASHERS," has been compiled to provide the most recent information on design, features, troubleshooting, service and repair procedures.

GOALS AND OBJECTIVES

The goal of this Job Aid is to provide detailed information that will enable the service technician to properly diagnose malfunctions and repair the 1998 lineup of Dishwashers.

The objectives of the Job Aid are:

The service technician will -

- Understand proper safety precautions.
- Successfully troubleshoot and diagnose malfunction.
- Successfully perform necessary repairs.
- Successfully return the dishwasher to proper operational status.

ADDITIONAL INFORMATION

Complete instructions on the disassembly and servicing of the Power Clean Filter Module are available in the Job Aid, "POWER CLEAN FILTER PUMP MOTOR ASSEMBLY SERVICE," Part No. 4322455. This Job Aid, and the accompanying video tape, Part No. 4322456V, have been revised to include specific details on the most recent version of this dishwasher pump and motor assembly.



WHIRLPOOL CORPORATION ASSUMES NO RESPONSIBILITY
FOR ANY REPAIRS MADE ON OUR PRODUCTS BY ANYONE
OTHER THAN AUTHORIZED SERVICE TECHNICIANS.

TABLE OF CONTENTS

INTRODUCTION.....	II
TABLE OF CONTENTS.....	III
SECTION ONE	
THEORY OF OPERATION	
Console Configuration	1
Pump and Motor Operation	2
SECTION TWO	
COMPONENT ACCESS	
Component Location	3
Removing Access and Outer Door Panels	4
Removing the Heater Element	5
Replacing the Heater Element	5
Servicing the Vertical Water Tube	6
Removing the Pump and Motor Assembly	7
Servicing the Operating Thermostat	8
Servicing the Soil Sensing System	8
Removing the Inside Door Panel	8
Dishwasher Dispenser Disassembly	9
SECTION THREE	
DIAGNOSIS AND TROUBLESHOOTING	
Troubleshooting Guide (Model DU910PFG)	11
Troubleshooting Guide (Models DP920PFG, DU920PFG, GU940SCG, GU960SCG, GU980SCG)	12
Component Diagnosis	13
SECTION FOUR	
TECH TIPS	
Wiring Diagram and Cycle Timing Chart (Model DU910PFG).....	15
Strip Circuits (Model DU910PFG)	16
Wiring Diagram (Model DP920PFG, DU920PFG, GU940SCG, GU960SCG, GU980SCG)	18
Cycle Timing Chart (Model DP920PFG, DU920PFG, GU940SCG, GU960SCG, GU980SCG)	19
Cycle Timing Chart Notes (Model DP920PFG, DU920PFG, GU940SCG, GU960SCG, GU980SCG)	20
Diagnostic and Sales Demo Timing Chart (Model DP920PFG, DU920PFG, GU940SCG, GU960SCG, GU980SCG)	21
Strip Circuits (Model DP920PFG, DU920PFG, GU940SCG, GU960SCG, GU980SCG)	22
Custom Door Panel Conversion	23
Floor Mount Kit	27
Warranty Information	28
Model and Serial Number Designators	29
Service Contact Information	30

Section One THEORY OF OPERATION

1998 POWER CLEAN FILTER MODELS

Console Configuration

Model DU910PFG



Models DP920PFG, DU920PFG



Model GU940SCG



Model GU960SCG



Model GU980SCG



PUMP AND MOTOR OPERATION

1. Once the tub has filled with hot water the motor begins to rotate forcing the water up through the pump chamber and out through the spray arms. Two spray jets on the underside of the lower spray arm direct water down onto the fine mesh screen of the pump housing to clear soils that may collect there during the wash cycle.
2. As water and soils return to the lower pump area, the chopper blade grinds the particles into smaller sizes that then pass through the perforated plate into the upper chamber of the pump. The pump impeller causes the soil laden water to be lifted and moved to the outer edges of the pump chamber where they are forced into the separator. Clean water is then forced up through the spray arms and fine mesh screen.
3. When the drain cycle begins, the drive motor changes direction. This relieves the pressure on the two check balls, opening the drain system.
4. Water is pumped from the tub carrying soils from the separator into the drain sump of the pump.
5. Soiled water is pumped out of the dishwasher through the check valve and drain hose.

Section Two COMPONENT ACCESS

COMPONENT LOCATION

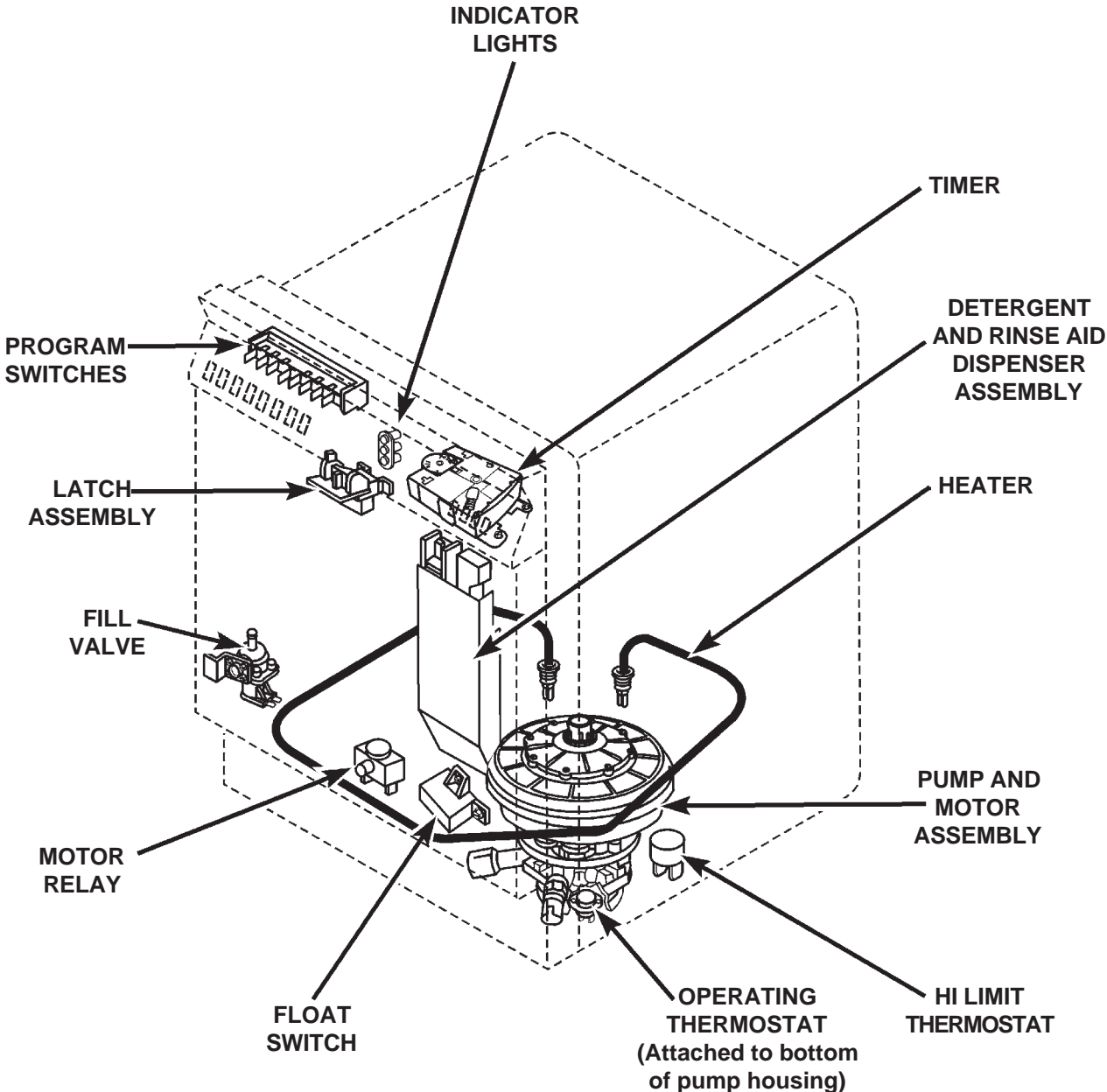

Removing Access and Outer Door Panels

1. Loosen but do not remove the two (2) toe panel screws below the access panel. Remove and set aside the two (2) screws above the access panel. (Fig. 2-1)
2. Remove the access panel assembly by sliding it upward to clear the loosened screws. (Fig. 2-1)
3. Remove the two (2) screws from the bottom of the outer door panel. (Fig. 2-1)
4. Pull the bottom of the outer door panel outward and slide it down approximately $\frac{1}{4}$ " to $\frac{1}{2}$ ". The panel will then be free for removal. (Fig. 2-1, inset)
5. Remove the existing door insulation. Access to the detergent and rinse aid dispensers is now possible.

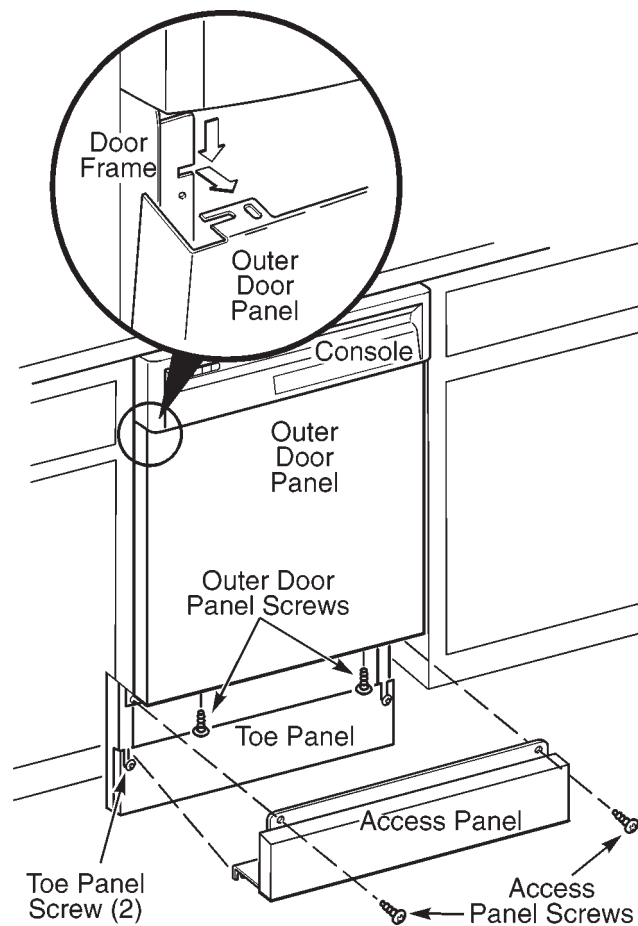

Fig. 2-1

Removing the Heater Element

From beneath the cabinet:

1. Remove the front access panel. (See Removing the Outer Door Panel)
2. Pull the spade connectors off the heater element terminals.
3. Unscrew the two (2) nuts securing the heater element to the bottom of the tub. (Fig. 2-2)

From inside the tub:

4. Remove the lower dish rack.
5. Remove the lower spray arm.
6. Slide the metal disks from the metal clips securing the left and right sides of the heater element.
7. Carefully lift the heater element from the unit.

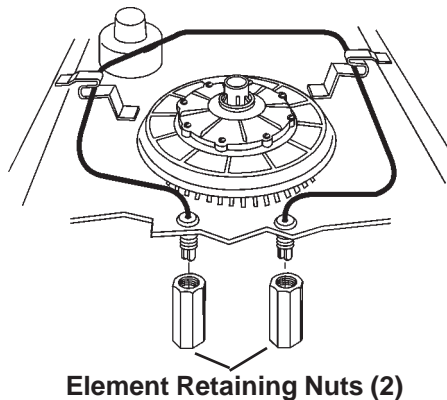

Fig. 2-2

Replacing the Heater Element

From inside the tub:

1. Carefully place the terminal ends of the heater element through the two (2) holes at the bottom rear of the cabinet.
2. Slide the metal disks into the clips to secure the left and right sides of the heater element.
3. Replace the lower spray arm.
4. Replace the lower dish rack.

From underneath the cabinet:

5. Secure the heater element in place with two (2) nuts. Be sure the element is seated firmly against the tub.
6. Slide the spade connectors onto the heater element terminals.
7. Replace the front access panel.

Servicing the Vertical Water Tube

The vertical water tube in these models delivers water to the spray arm mounted underneath the upper dish rack and a smaller spray arm mounted at the top of the dishwasher tub. (Fig. 2-3)

If the pump and motor assembly must be removed for servicing, the vertical water tube must be disconnected from the pump cover as follows:

1. Remove the upper dish rack.
2. Dislodge the upper portion of the vertical water tube from the plastic knob on the back of the tub by pressing down on the nozzle. (Fig. 2-4)
3. Pull the securing tabs of the clamp holding the internal water feed tube to the pump outlet nozzle and remove the clamp. (Fig. 2-5)
4. Rotate the lower end of the tube either left or right off the pump nozzle. (Fig. 2-6)

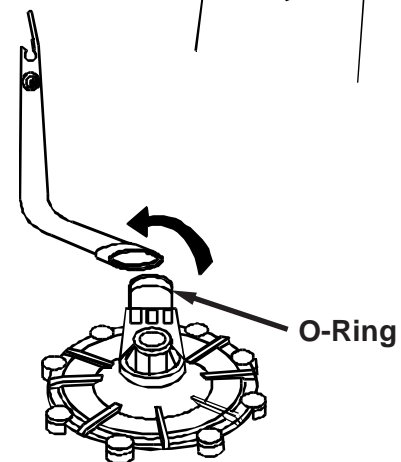
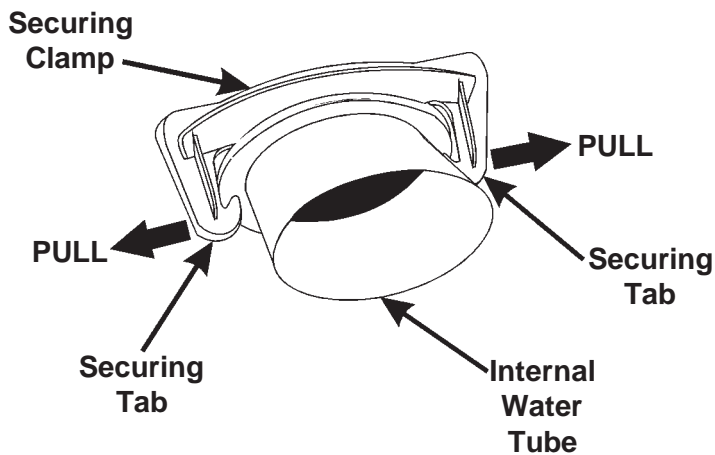
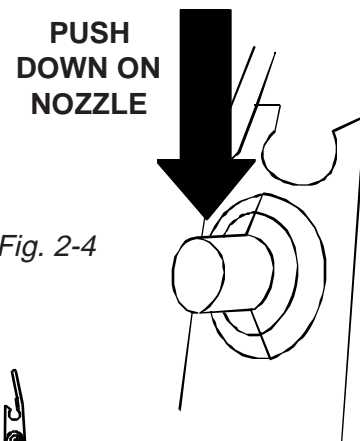
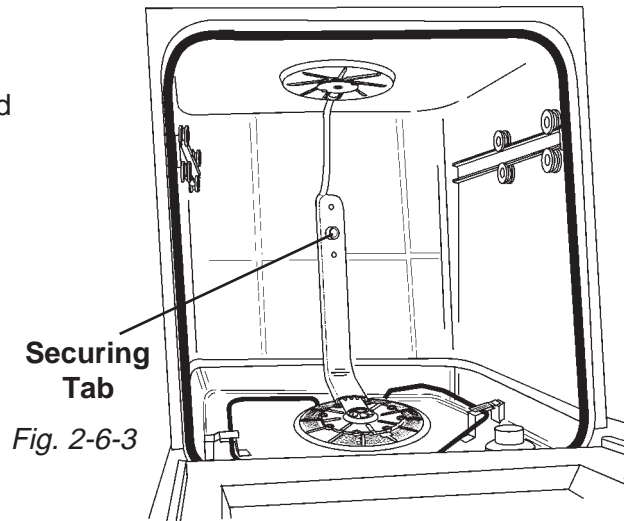

-- NOTE --

Do not pull the vertical water tube forward or up in an attempt to remove it from the pump nozzle. The smaller spray arm at the top of the tub does not need to be removed to service the pump and motor assembly.

Removing the Pump Motor Assembly

1. Unscrew and remove the nozzle cap and remove the nozzle bearing and spray arm. (Fig. 2-7)
2. Disconnect the wiring harness from the motor harness plug.
3. Rubber clamps secure the pump and motor assembly to the tub. Rotate these inward 90°. (Fig. 2-8)
4. Remove the drain hose and clamp from the check valve and unscrew the check valve from the pump. (Fig. 2-9)
5. Remove the tuned sound absorber. Use an open-end wrench to loosen the shaft from the motor. Do not loosen the sound absorber by torquing on the large tuned resonator.

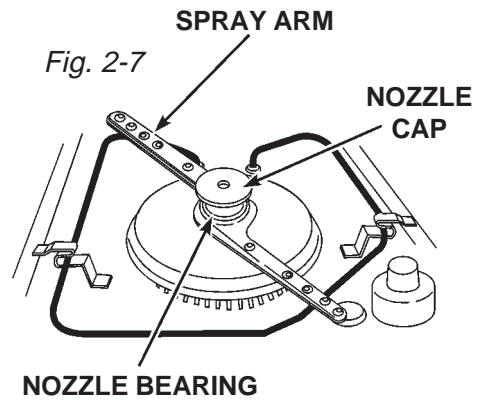

-- NOTE --

A small container will be required to catch water from the drain hose after removal.

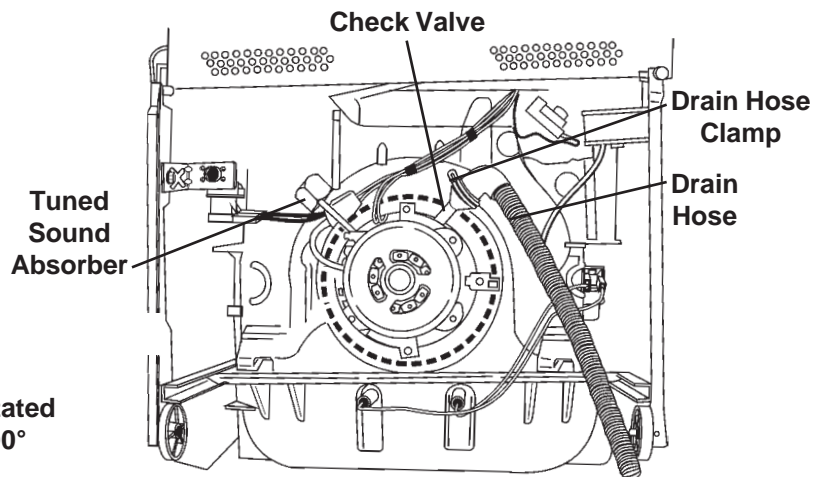
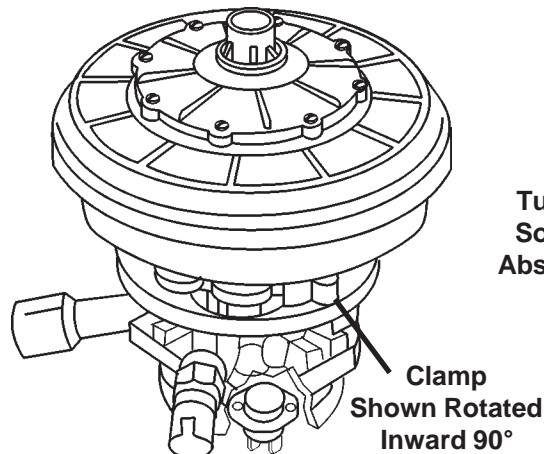

6. Remove the pump and motor assembly by pulling up through the inside of the tub. (Fig. 2-10)

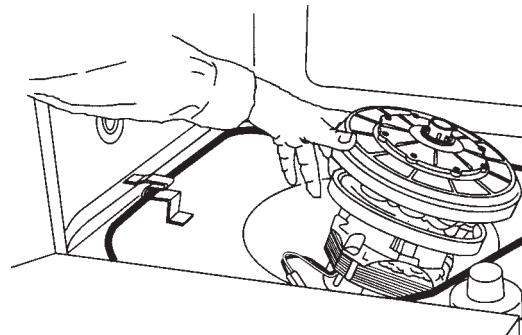

Servicing the Operating Thermostat

The operating thermostat is secured to the bottom of the pump housing. (Fig. 2-11)

1. Disconnect the two (2) wiring harness leads from the terminals on the thermostat.
2. Remove the two (2) Hex-head screws securing the thermostat to the pump housing.

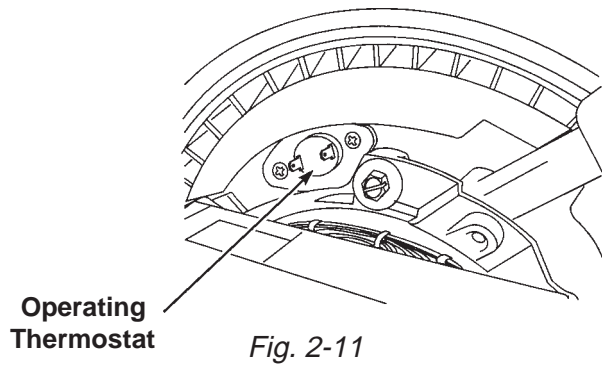

Servicing the Soil Sensing System

The Soil Sensing System consists of a pressure sensitive switch connected to the dishwasher pump base. (Fig. 2-12) The system detects excessive amounts of food soils during the sensing portion of the wash cycle and signals the electronic control board to either terminate the wash cycle and initiate drain to flush soils from the system or skip certain parts of the heavy soil cycle.

The pressure switch is connected to the pump base through a plastic hose. The pressure switch is secured to the bottom of the dishwasher tub by two (2) Hex-head screws.

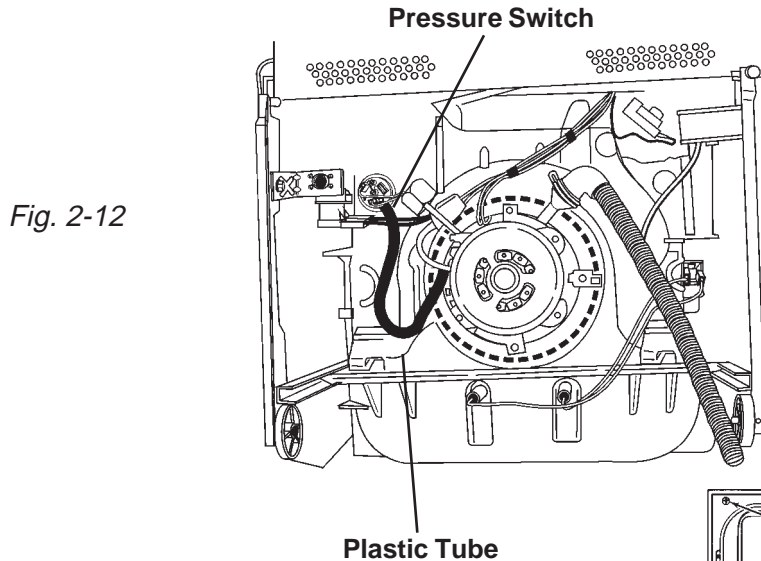

Removing the Inside Door Panel

1. Disconnect the dishwasher from the electrical supply.
2. Disconnect the end of the door springs from the door spring tension adjustment holes in the frame runner.
3. Open the dishwasher door and remove the eight (8) T-15 Torx screws securing the inner door panel from the door frame. (Fig. 2-13)
4. Slide the inner door panel back toward the dishwasher to disengage the spring loaded locking tab from the door panel, then lift the door panel away from the door. (Fig. 2-14)
4. Remove the control cover.

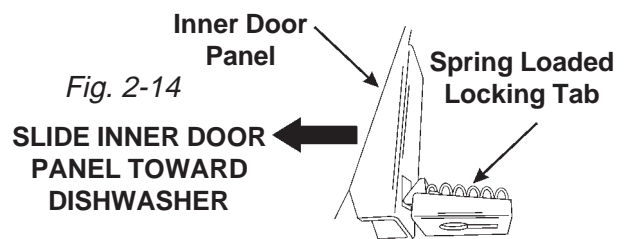
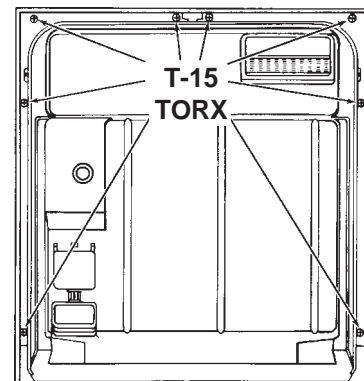

Dishwasher Dispenser Disassembly

1. Remove the drawbar spring. (Fig. 2-15)
2. Grasp the lower edge of the drawbar and pull it away from the panel stop. Slide the drawbar down until the draw bar holes align with the locking tabs, then remove the drawbar. Note how the locating tabs behind the drawbar align with their respective locating holes in the drawbar. (Fig. 2-16)
3. Turn the wet agent cap and seal assembly counterclockwise and remove it. (Fig. 2-17)
4. Remove the seal from the cap.
5. Use Special Tool - Part No. 303918 or a $\frac{3}{4}$ " socket to press over the attaching tabs in the wet agent cap opening. Remove wet agent dispenser assembly. (Fig. 2-17)
6. Remove wet agent dispenser actuator by spreading the two (2) locking tabs. (Fig. 2-18)
7. Remove the actuator slide from the wet agent dispenser actuator.
8. Remove the diaphragm spring and diaphragm.
9. Use a screwdriver to gently release the lower tab and remove the detergent door actuator assembly. As you do, note the position of the door latch level through the hole in the lower slide. (Fig. 2-19)
10. Remove the detergent door latch by carefully spreading the latch snap locking tabs apart with a screwdriver while pushing firmly against the end of the door latch lever until the lever is released through the hole.
11. Remove the upper slide, the slide spring and the lower slide. (Fig. 2-20)

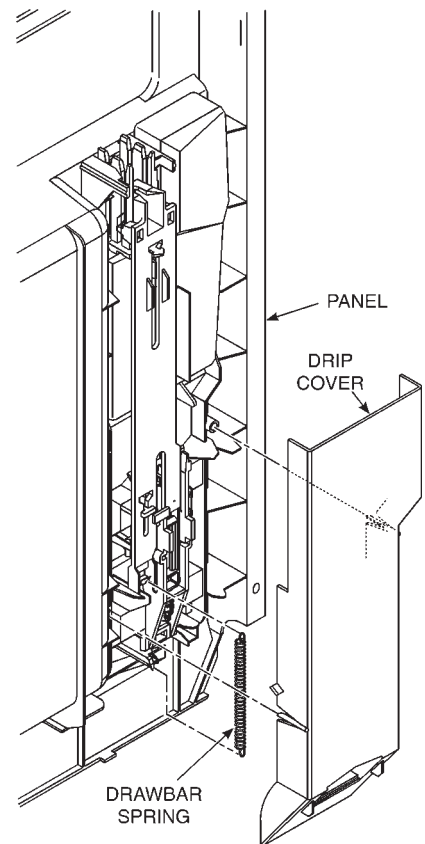

Fig. 2-15

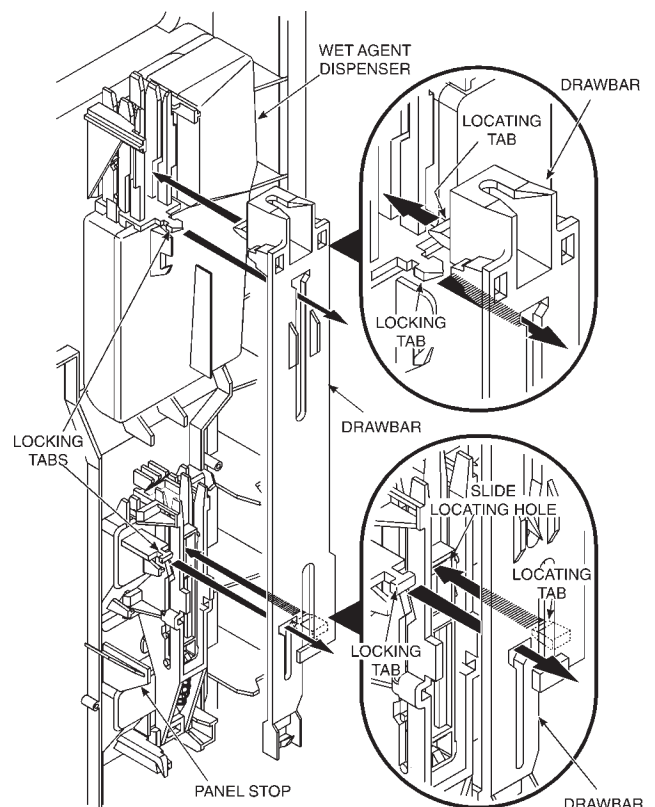

Fig. 2-16

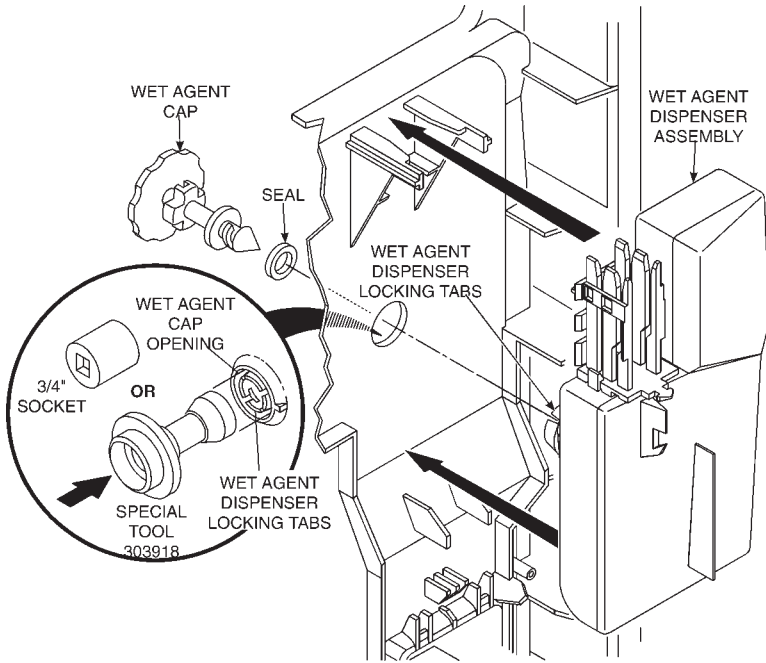

Fig. 2-17

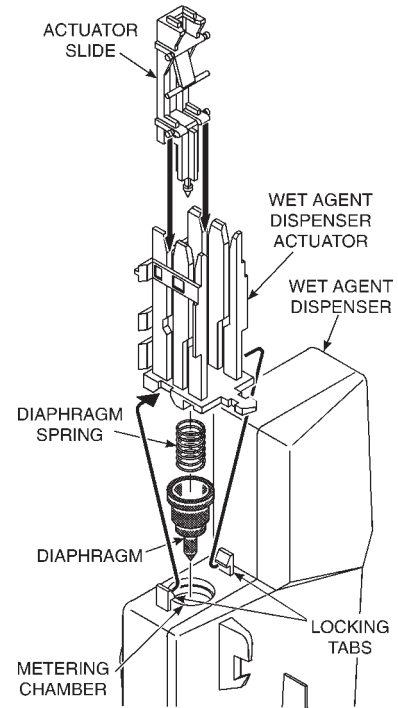

Fig. 2-18

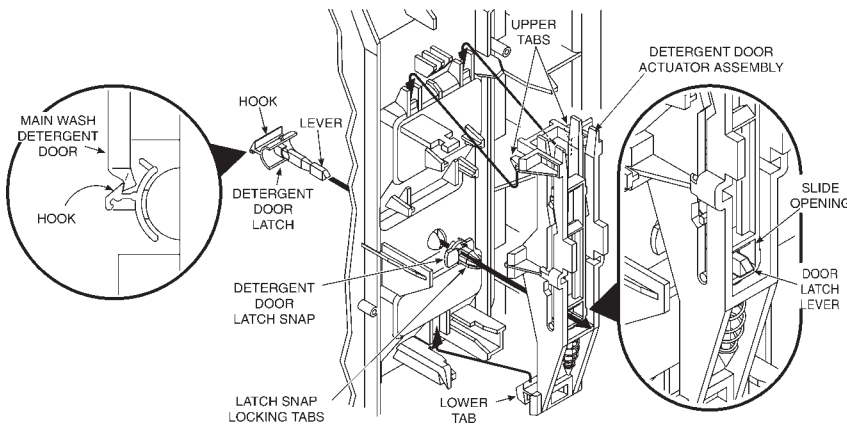

Fig. 2-19

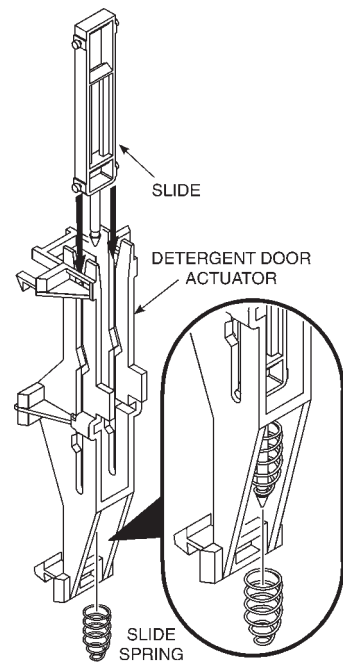

Fig. 2-20

Section Three

DIAGNOSIS AND TROUBLESHOOTING

TROUBLESHOOTING GUIDE

Model DU910PFG

PRECAUTIONS TO BE OBSERVED WHILE TROUBLESHOOTING

Always check wiring harness and connectors before initiating any test procedures.

Disconnect electric power from the dishwasher before touching the printed circuit boards or re-seating wire connectors.

Voltage checks should be made by inserting meter probes beside the wires in the connector blocks with the electric power source on and the connector block plugged in.

Resistance checks should be made on components with the electric power off and the connector blocks disconnected.

PROBLEM	POSSIBLE CAUSES	CORRECTION/TEST
Dishwasher does not run or stops during a cycle	<ol style="list-style-type: none"> 1. Door is not latching properly. 2. Child lock is "ON". 3. Wash Cycle not set properly. 4. Household fuse blown or circuit breaker tripped. 5. Washer is not wired into a circuit with proper voltage. 	<ol style="list-style-type: none"> 1. Check to make sure handle link is properly seated in door latch assembly. Check that the door switch is opening and closing properly. 2. Turn child lock "OFF" 3. Review setting Wash Cycles in the Use and Care Guide. 4. Have a qualified electrician check the circuit breaker or fuse. 5. Have customer call a qualified electrician.
Dishwasher will not fill	<ol style="list-style-type: none"> 1. Overflow protection float is stuck in "up" position. 2. Fill valve is inoperable. 3. Open timer contacts. 	<ol style="list-style-type: none"> 1. Check that the overflow protection float is free to move "up" and "down". Check that the overfill switch is opening and closing properly. 2. Check for continuity between contacts on fill valve. 3. Test timer contacts.
Dishwasher will not drain	<ol style="list-style-type: none"> 1. Air gap (if installed) is clogged. 2. Pump motor is inoperable. 3. Open timer contacts. 	<ol style="list-style-type: none"> 1. Follow air gap manufacturer's direction for cleaning. 2. Disconnect pump motor from wiring harness and check for continuity. 3. Test timer contacts.
Dishwasher will not dry dishes	<ol style="list-style-type: none"> 1. Heater element burned out. 2. HI-limit thermostat inoperable. 3. Open circuit between timer and heater. 	<ol style="list-style-type: none"> 1. Check for continuity between the terminals of the heater element. 2. Check for continuity between terminals of the hi-limit thermostat. 3. Check for continuity between timer switch contacts and heater.

TROUBLESHOOTING GUIDE

Models DP920PFG, DU920PFG, GU940SCG, GU960SCG and GU980SCG

PRECAUTIONS TO BE OBSERVED WHILE TROUBLESHOOTING

Always check wiring harness and connectors before initiating any test procedures.

Disconnect electric power from the dishwasher before touching the printed circuit boards or re-seating wire connectors.

Voltage checks should be made by inserting meter probes beside the wires in the connector blocks with the electric power source on and the connector block plugged in.

Resistance checks should be made on components with the electric power off and the connector blocks disconnected.

PROBLEM	POSSIBLE CAUSES	CORRECTION/TEST
Dishwasher does not run or stops during a cycle	<ol style="list-style-type: none"> 1. Door is not latching properly. 2. Child lock is "ON". 3. Wash Cycle not set properly. 4. Household fuse blown or circuit breaker tripped. 5. Washer is not wired into a circuit with proper voltage. 	<ol style="list-style-type: none"> 1. Check to make sure handle link is properly seated in door latch assembly. Check that the door switch is opening and closing properly. 2. Turn child lock "OFF" 3. Review setting Wash Cycles in the Use and Care Guide. 4. Have a qualified electrician check the circuit breaker or fuse. 5. Have customer call a qualified electrician.
Dishwasher will not fill	<ol style="list-style-type: none"> 1. Overflow protection float is stuck in "up" position. 2. Fill valve is inoperable. 3. Control board is inoperable. 	<ol style="list-style-type: none"> 1. Check that the overflow protection float is free to move "up" and "down". Check that the overfill switch is opening and closing properly. 2. Check for continuity between contacts on fill valve. 3. Check for 110VAC between P2-5 and P12-3.
Dishwasher will not drain	<ol style="list-style-type: none"> 1. Air gap (if installed) is clogged. 2. Pump motor is inoperable 3. Control board is inoperable. 	<ol style="list-style-type: none"> 1. Follow air gap manufacturer's direction for cleaning. 2. Disconnect pump motor from wiring harness and check for continuity between V & BU, V & GY and V & Y. 3. Check for 110VAC between P10 and P3, P10 and P5 and P10 and P4.
Dishwasher will not dry dishes	<ol style="list-style-type: none"> 1. Heater element burned out. 2. Hi-limit thermostat inoperable. 	<ol style="list-style-type: none"> 1. Check for continuity between the terminals of the heater element. Check for 110VAC between P6 and P8. 2. Check for continuity between terminals of the hi-limit thermostat.

COMPONENT TESTING

PRECAUTIONS TO BE OBSERVED WHILE DIAGNOSING PROBLEM COMPONENTS

Disconnect electric power from the dishwasher.

Voltage checks should be made by inserting meter probes beside the wires in the connector blocks with the electric power source on and the connector block plugged in.

Resistance checks should be made on components with the electric power off and the connector blocks disconnected.

COMPONENT SCHEMATIC	TESTING PROCEDURE	RESULTS
Motor Start Relay	<ol style="list-style-type: none"> 1. Disconnect the wire connectors and remove relay from unit. 2. Set VOM meter on the Rx1 scale. 3. Set the relay upright. 4. Measure resistance between blue and violet contacts. 5. Turn relay upside-down. 6. Measure resistance between blue and violet contacts. 	<ol style="list-style-type: none"> 1. Relay upright - meter should read ∞ (infinity.) 2. Relay upside-down - meter should read less than two (2)Ω.
Drive Motor	<ol style="list-style-type: none"> 1. Disconnect the motor wiring harness plug from the motor connector. 2. Set VOM meter on the Rx1 scale. 3. Connect one probe to the white/violet connector. 4. Connect the other probe to the blue/white connector. 5. Connect the meter probe to the yellow connector. 6. Connect the probe to the grey connector. 	<ol style="list-style-type: none"> 1. Violet to blue - meter should read 2.0 - 3.4Ω. 2. Violet to Yellow - meter should read 4.2 - 7.0Ω. 3. Violet to Gray - meter should read 4.2 - 7.0Ω.
Thermal Fuse	<ol style="list-style-type: none"> 1. Disconnect wires connectors from the thermal fuse terminals. 2. Set VOM meter to read Rx1 scale. 3. Measure resistance between thermal fuse terminals. 	<ol style="list-style-type: none"> 1. Meter should read 0Ω.
Heater Element	<ol style="list-style-type: none"> 1. Disconnect the wire connectors from the heater element terminals. 2. Set VOM meter to read Rx1 scale. 3. Measure resistance between heater element terminals. 	<ol style="list-style-type: none"> 1. Meter should read 25 - 35Ω.
Fill Valve	<ol style="list-style-type: none"> 1. Disconnect the wiring harness plug from the fill valve connector. 2. Set VOM meter to read Rx1 scale. 3. Measure resistance between the terminals of the fill valve. 	<ol style="list-style-type: none"> 1. Meter should read approximately 700Ω.
Overfill Switch	<ol style="list-style-type: none"> 1. Disconnect the wires connectors from the overfill switch terminals. 2. Set VOM meter to read Rx1 scale. 3. Measure resistance between switch terminals. 4. Block the float in the UP (full) position and measure resistance again. 	<ol style="list-style-type: none"> 1. Float DOWN - meter should read 0Ω. 2. Float UP - meter should read ∞ (infinity).

COMPONENT SCHEMATIC	TESTING PROCEDURE	RESULTS
Timer Motor	<ol style="list-style-type: none"> 1. Disconnect the Wiring harness connector from the timer assembly. 2. Set VOM meter on the Rx1 scale. 3. Measure resistance between timer motor terminals. 	<ol style="list-style-type: none"> 1. Meter should read 1800 - 3000Ω.
Timer	<ol style="list-style-type: none"> 1. Disconnect the wiring harness connector from the timer assembly. 2. Set VOM meter on the Rx1 scale. 3. Connect one probe to contact 31. (Tan) 4. Connect the other probe to the timer contact to be tested. 5. Manually advance the timer until the contact closes. 6. Manually advance the timer until the contact opens. 	<ol style="list-style-type: none"> 1. Contact CLOSED - meter should read 0Ω. 2. Contact OPEN - meter should read ∞ (infinity).
Dispenser Mechanism	<ol style="list-style-type: none"> 1. Remove the front door panel. 2. Remove the drip cover. 3. Latch the detergent door closed. 4. Manually advance the timer through a complete cycle slowly. 	<ol style="list-style-type: none"> 1. At 12 o'clock position - Draw bars will move upward causing the detergent actuator assembly to release the latch and detergent cup should open. 2. At 4 o'clock position - Draw bars will again move upward causing the wetting agent actuator to release wetting agent. 3. From the 6 o'clock position to the 8 o'clock position the draw bars are driven down to reset the mechanism.

Section Four TECH TIPS Model DU910PFG

Wiring Diagram

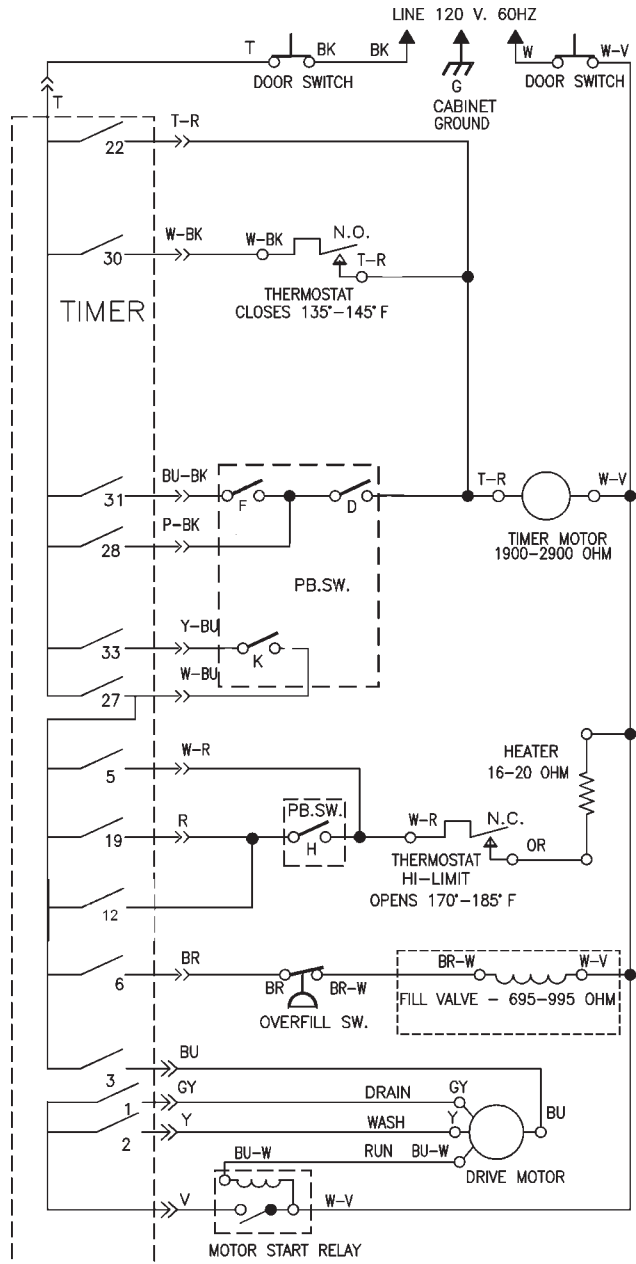

Cycle Timing Charts

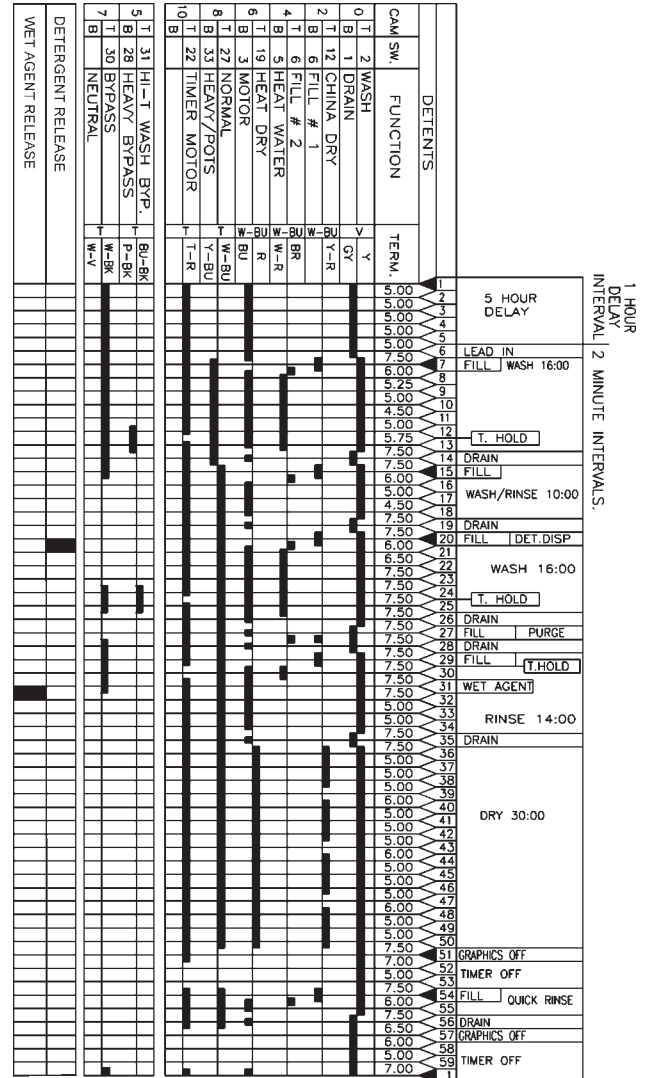

Strip Circuits (DU910PFG)

1. Fill

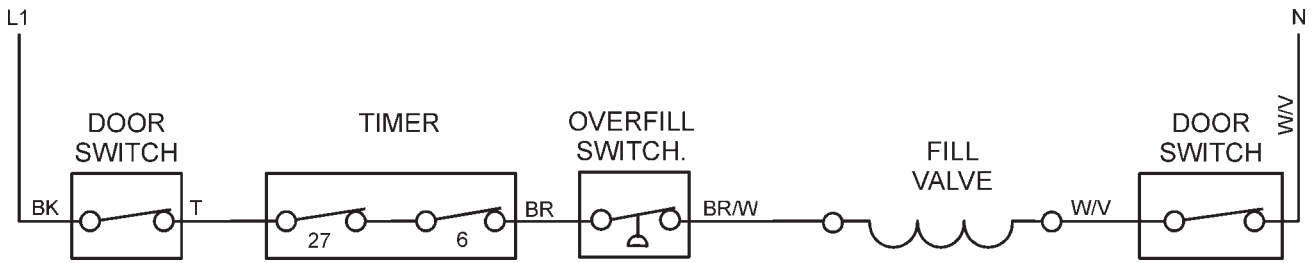

2. Water Heat

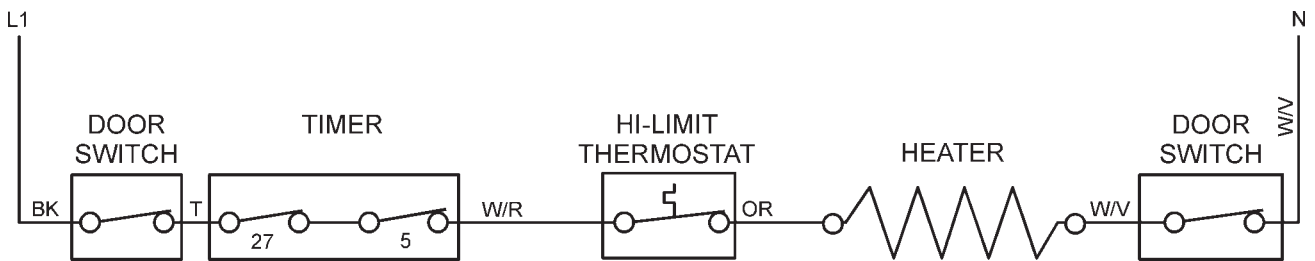

3. Wash

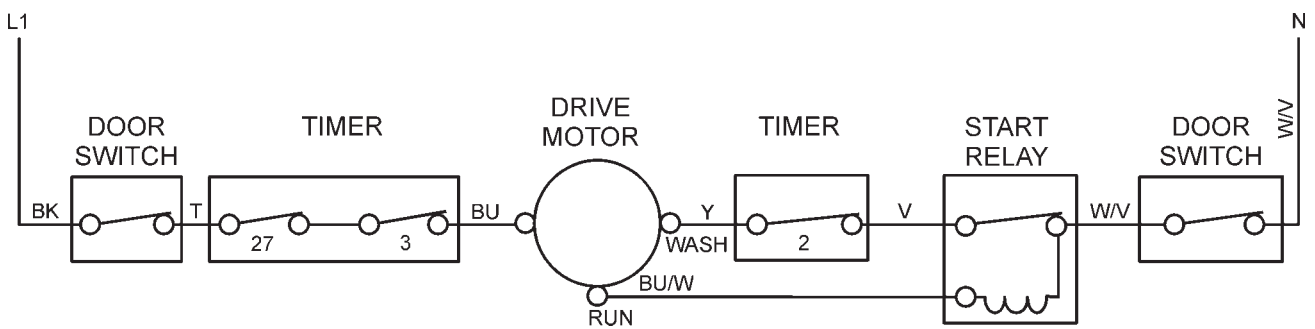

4. Drain

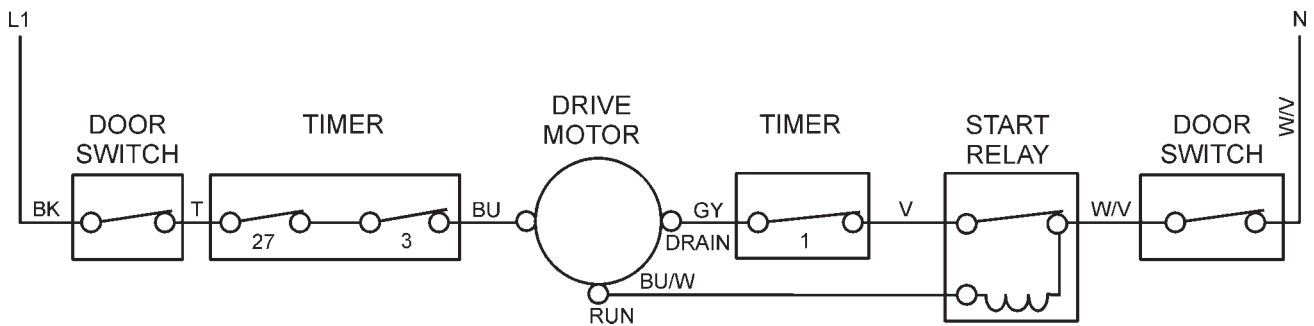

5. Heat Dry

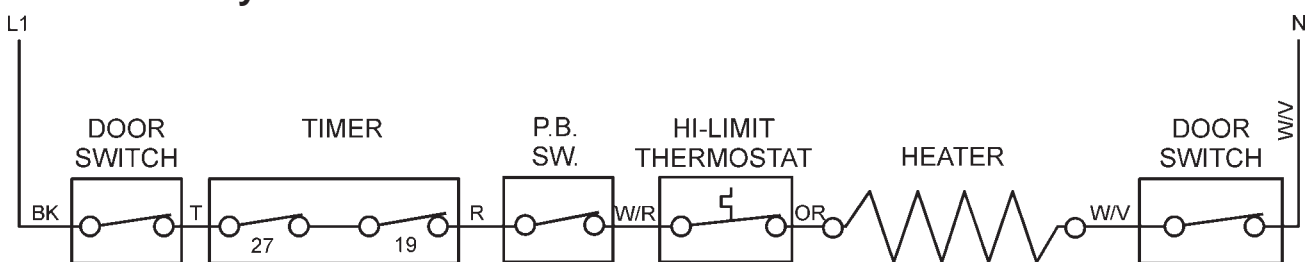

Models DP920PFG, DU920PFG, GU940SCG, GU960SCG & GU980SCG

WIRING DIAGRAM

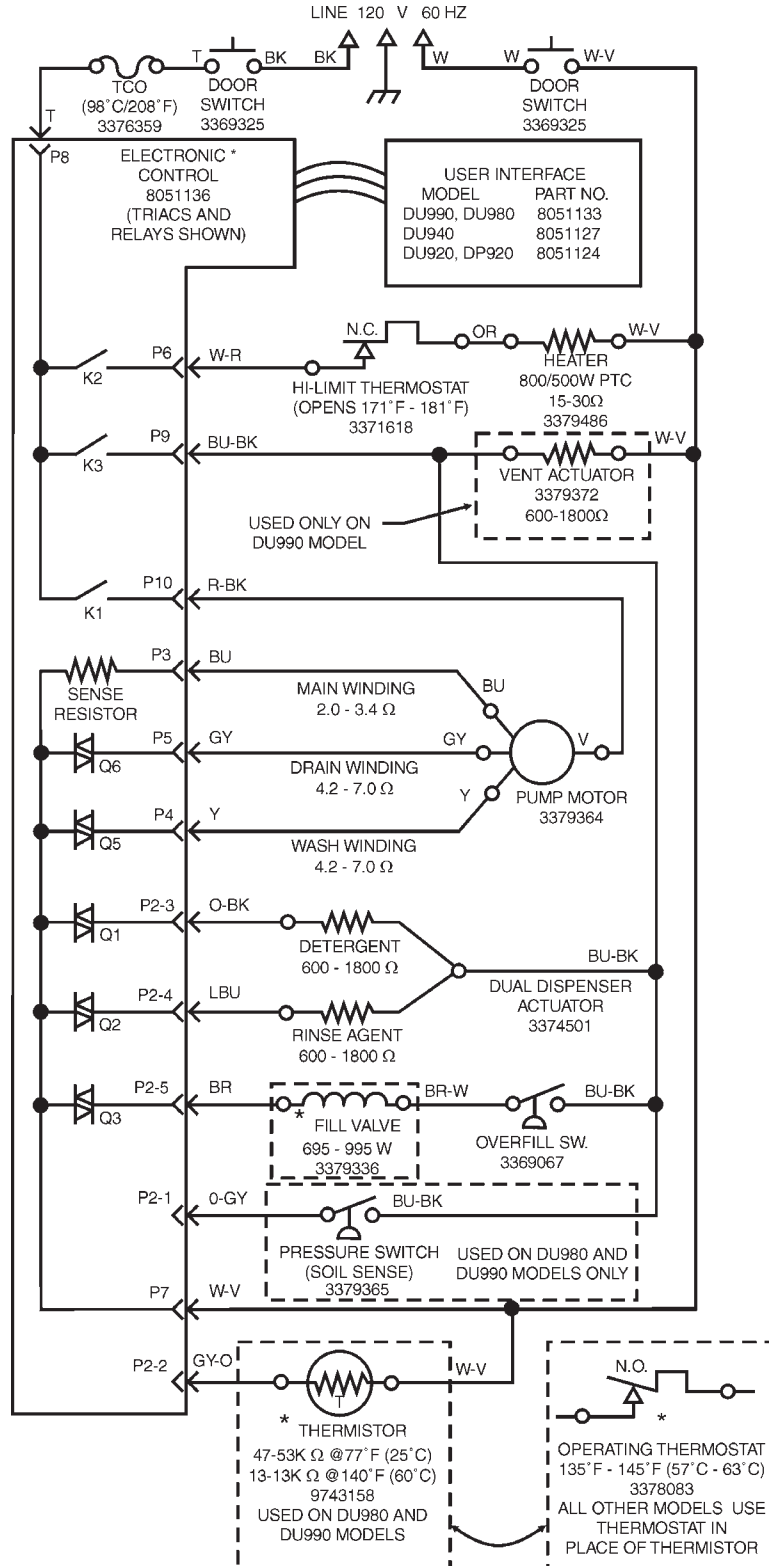

Cycle Timing Chart

INTERVAL	41	40	39	38	37	36	35	34	33	32	31	30	29	28	27	26	25	24	23	22	21	20	19	18	17	16	15	14	13	12	11	10	9	8	7	6	5	4	3	2	1	0
POTS 7 PANS	89:20																																									
SOIL SENSED																																										
HEAVY	84:20																																									
SOIL SENSED																																										
NORMAL																																										
SOIL SENSED	79:50																																									
SOIL NOT SENSED	69:40																																									
LOW ENERGY	66:40																																									
SOIL SENSED	79:50																																									
CHINA CRYSTAL	66:40																																									
SOIL SENSED																																										
QUICK WASH	26:30																																									
NOT SENSED																																										
RINSE ONLY	18:30																																									
SOIL SENSED																																										
O POWER SCOUR	NOTE 10																																									
P HIGH TEMP WASH	NOTE 10																																									
T SANI RINSE	NOTE 10																																									
S AIR DRY	NOTE 10																																									
S WASHING																																										
T RINSING																																										
A DRYING																																										
T ADD-A DISH																																										
U WATER HEATING																																										
S SANI COMPLETE	NOTE 11																																									
CLEAN																																										
O MOTOR																																										
U WASH	NOTE 12																																									
T DRAIN	NOTE 13																																									
P FILL																																										
U DETERGENT DISPENSER																																										
T WETTING AGENT DISPENSER																																										
S VENT																																										
HEATER																																										
REFERENCE NOTES																																										
NORMAL CYCLE TIMES																																										
POTS & PANS CYCLE TIMES																																										

CYCLE TIMING CHART NOTES

Note 1: Pre-Wash Sense Interval

Pressure switch contact closure at any time during this interval causes the cycle to jump to interval 37. Immediately. For the normal cycle, the heater is "off" during this interval. For the heavy and pots-n-pans cycles the heater is "on" during this interval. The power scour option changes this interval to a 16 minute heated wash interval for all 3 cycles (normal, heavy and pots-n-pans). If the water temperature reaches 140°F or the thermostat closes. The heater is turned "off". Time continues to elapse and all other output states remain the same until the prescribed interval time has elapsed.

Note 2: Pre-Wash Thermal Hold

This thermal hold is only executed during the heavy and pots-n-pans cycles. The thermal hold setpoint is 140°F or thermostat contact closure and the default time is 25 minutes.

Pressure switch contact closure at any time during this interval causes the cycle to jump to interval 37. Immediately.

Note 3: Pre-Rinse Sense Interval

Pressure switch contact closure at any time during this interval causes the cycle to jump to interval 31. Immediately. For the normal cycle, the heater is "off" during this interval. For the heavy and pots-n-pans cycles the heater is "on" during this interval. The power scour option changes this interval to a heated wash interval for the normal cycle. If the water temperature reaches 140°F or the thermostat closes. The heater is turned "off". Time continues to elapse and all output states remain the same until the prescribed interval time has elapsed.

Note 4: Pre-Rinse Thermal Hold

This thermal hold is only executed during the heavy and pots-n-pans cycles and only occurs if the pressure switch trips during the sense or thermal hold intervals of the pre-wash the thermal hold setpoint is 140°F or thermostat contact closure and the default time is 20 minutes. Pressure switch contact closure at any time during this interval causes the cycle to jump to interval 31. Immediately.

Note 5: Main Wash Thermal Hold

This thermal hold is automatic for the pots-n-pans and heavy cycles (set point = 140°F). For the normal cycle. This thermal hold is invoked by selecting the power scour or high temp wash options (Set Point = 140°F) or as a result of the pressure switch tripping during the pre-wash (Set Point = 130°F). For the low energy wash and quick wash cycles. This thermal hold is invoked by selecting the high temp wash option (Set Point = 140°F). In all cases, the default time for this thermal hold is 20 minutes

Note 6: Main Wash Recirculation Interval

The power scour option increases the length of this interval to 10:00 for the pots-n-pans and heavy cycles.

Note 7: Final Rinse Thermal Hold

This thermal hold is automatic for all cycles except the china wash and rinse only cycles (Set Point = 140°F). For the china wash cycle, this thermal hold only occurs if the pressure switch trips during the pre-rinse (Set Point = 130°F). In all cases the default time is 25 minutes.

If the sani rinse option is selected, then the set point for this thermal hold becomes 150°F and the default time changes is 25 minutes.

Note 8: Air Dry

The default status for the dry period is heat dry "on". Selecting the "air dry" option causes the heater to be turned "off" during this interval.

Note 9: China Dry Interval

When the china wash cycle is selected, the heater will be turned off during this interval.

Note 10: Option LED's

When a valid option is active, then the LED for the option will be "on".

Note 11: Sani Complete LED

When the "sani rinse" option has been selected and completed. A "sani complete" indicator is illuminated at the end of the cycle. During a cycle in which

"sani rinse" has been selected, the target thermal hold temperature for the "sani rinse" option must be satisfied and maintained. If this condition is not satisfied (because the final rinse thermal hold default time elapsed or power to the dishwasher was lost at any time during the remainder of the cycle that follows due to a door opening or AC line failure) then the sani complete indicator will flash on and off at the end of the cycle. Opening the door or pressing any key will turn the indicator off in either case.

Note 12: Motor Drain Phase Winding

This output is only "on" when the motor is starting in the wash mode. When the control has determined that the motor has started, the wash phase winding will be turned "off".

Note 13: Motor Drain Phase Winding

This output is only "on" when the motor is starting in the drain mode. When the control has determined that the motor has started. The drain phase winding will be turned "off".

Note 14: Diagnostic Sensor Input Test

The soil sense pressure switch input is active during this interval. Pressure switch contact closure at any time during this interval causes the cycle to jump to the next interval. Immediately.

Note 15: Diagnostic Thermal Hold

The default status for this thermal hold is "on". The thermal hold set point is 140°F or thermostat contact closure and the default time is 60 minutes. After 60 minutes, the thermal hold is terminated and normal cycle timing resumes. The diagnostic test cycle advance function can also be used to terminate this thermal hold.

Note 16: Cycle Complete

A clean indicator will be on at the end of this cycle. Opening the door or pressing any key will turn the indicator off.

Note 17: Diagnostics Cycle -- Thermostat/Thermistor Indicator

The "clean" LED will turn on during the display test at the beginning of the cycle (interval 11) and again at the conclusion of the cycle (interval 2) regardless of what it detects on the thermistor input. The "clean" LED will be on in intervals 1 through 8 of the cycle whenever an "open" (resistance greater than 200K OHMS. +/- 50K OHMS) is detected on the thermistor input by the control. Consequently, if a normally open operating thermostat were to be installed on the thermistor input, the "clean" LED would be on throughout the cycle until the thermostat tripped (e.g., during the thermal hold); With a thermistor installed, the clean LED would only be on in intervals 10 and 0. Because the thermistor always has a resistance of between 50 K-OHMS and 8 K-OHMS under normal operating conditions.

Options

Water Heat:

Forces a thermal hold to occur in the main wash regardless of soil level. The set point for this thermal hold is 140°F. This option is automatic with the pots-n-pans and heavy cycles. It is not available on china wash or rinse only cycles.

Sani Rinse:

Raises the setpoint temperature of the thermal hold in the final rinse to approximately 65°C/150°F. This option is not available with china wash, quick wash & rinse only cycles. This option is only possible on models that use a thermistor.

Air Dry:

Opens the circuit to the heater element during the dry period of the cycle. This option is not available on quick wash or rinse only cycles (which have no dry period).

Power Scour:

Inserts additional heated wash time into the pots-n-pans, heavy and normal cycle pre-wash sequence (interval 39 becomes a 16 minute, thermostatically controlled, heated wash). Turns the heater on in interval 33 of the normal cycle pre-rinse, invokes a thermal hold in the main wash of the normal cycle and extends interval 23 to 10 minutes in the pots-n-pans and heavy cycles. This option is not available on low energy, china wash, quick wash or rinse only cycles.

DIAGNOSTICS AND SALES DEMO TIMING CHART

INTERVAL	11	10	9	8	7	6	5	4	3	2	1	0
POTS & PANS HEAVY												
NORMAL												
LOW ENERGY												
CHINA												
QUICK WASH												
RINSE ONLY												
POWER SCOUR												
HIGH TEMP WASH												
SANI RINSE												
AIR DRY												
CANCEL												
DELAY 2 HR												
DELAY 4 HR												
DELAY 6 HR												
WASHING LED												
ADD-A-DISH LED												
WATER HEATING LED NOTE [4]												
SENSING LED NOTE [3]												
RINSING LED												
DRYING LED												
CLEAN LED NOTE [5] [6]		(17)	(17)	(17)	(17)	(17)	(17)	(17)	(17)			
CONTROL LOCKED LED												
SANI COMPLETE LED												
MINUTES												
SECONDS	3	2	6	2	TH	2		1	6		6	
VENT (disp., fill, soil enable)												
MOTOR												
WASH DIRECTION NOTE [2]												
DRAIN DIRECTION NOTE [2]												
FILL												
DETERGENT DISPENSER												
RINSE AGENT DISPENSER												
HEATER												
SOIL SENSE NOTE [3]												
REFERENCE NOTES												
WHIRLPOOL '98 DIAGNOSTICS												

DIAGNOSTICS AND SALES DEMO TIMING CHART NOTES

- The diagnostics test cycle starts at interval 11 and concludes at interval 2. To initiate the diagnostics test cycle, press the following sequence of keys within 10 seconds:

High Temp Wash, Air Dry, High Temp Wash, Air Dry
or
Power Scour, Air Dry, Power Scour, Air Dry

The diagnostics test cycle may be manually advanced to the next interval by pressing the pots & pans key. To exit diagnostics, press cancel.

- The sales demo cycle consists of a single 6-minute wash interval which starts at interval 1 and concludes at interval 0. To initiate the sales demo cycle, press the following sequence of keys within 10 seconds:

High Temp Wash, Air Dry, High Temp Wash, Air Dry, High Temp Wash
or
Power Scour, Air Dry, Power Scour, Air Dry, Power Scour

- The diagnostics test cycle executes a soil sensing interval at interval 9 to test the soil sensing circuit. The sensing LED is illuminated throughout this sense interval.

If the soil sensing pressure switch is tripped at any time during this sense interval, the control will immediately terminate the sense interval and proceed with the remainder of the diagnostics cycle.

If the time limit for this sense interval elapses without detecting soil, the control simply proceeds with the remainder of the diagnostics cycle.

- The diagnostics cycle suspends cycle timing and executes a thermal hold at interval 7. The thermal hold interval is terminated and cycle timing resumes when the water is heated to the desired set point temperature (60°C/140°F). The maximum default time limit elapses (1 hour), or the cycle is manually advanced to the next interval by pressing the pots & pans key. The water heating LED is illuminated during the thermal hold.

- The clean LED is illuminated at the end of both the diagnostics test cycle and the sales demo cycle. The clean LED can be extinguished by opening the door or pressing any key.

- During intervals 9 through 3 of the diagnostics cycle, the clean LED is

illuminated whenever the control detects a resistance of greater than approximately 45 K-OHMS on the thermistor/ thermostat circuit. This feature is intended to help determine whether a thermostat or thermistor is installed. A thermostat with normally open contacts would trigger the clean LED (until the thermostat is tripped). Under normal operation, the resistance of the thermistor is always less than 45 K-OHMS and would not trigger the clean LED.

- The wash and drain auxiliary windings are only "on" when the motor is being started. When the control has determined that the motor has been started satisfactorily, the auxiliary winding will be turned "off".

- Entering the key sequence high temp wash (or power scour), air dry, high temp wash (or power scour), air dry, after a cycle has started, will enable the pots-n-pans key rapid advance feature. This will allow service to rapidly step to any interval of the currently running cycle.

Other Control Features:

Cancel/Drain:
Terminates current active cycle and clears cycle selections. Executes 2-minute drain upon first selection if water is likely to be left in sump. Subsequent selections toggle between 2-minute drains and going to standby.

Control Lock:
The control lock LED is illuminated and all keys of the keyboard are disabled whenever the control lock feature is invoked by the customer. The control lock feature (and LED) can be turned on or off by the customer at any time by holding down the air dry option key for 4 seconds.

Delay Start:
Allows the customer to delay the start of a cycle by up to 6 hours. Each press of the delay key increases the delay time selection by two hours. The selected delay period will begin clocking down upon selecting the cycle key. The cycle selected will begin automatically upon completing the delay period.

Error Messages:

Stuck Key:
If the control detects that a key is stuck in the depressed position, dishwasher operation will be suspended and the control will flash the LED associated with that key until the condition is corrected. If a key without an LED is stuck or multiple keys are stuck, the control will flash the lock-out LED.

Strip Circuits (DU920PFG, DP920PFG, GU940SCG, GU960DCG, GU980SCG)

1. Fill

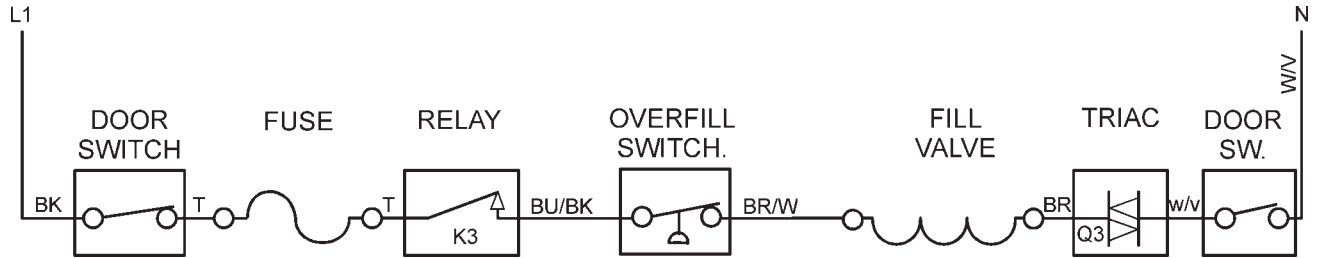

2. Water Heat

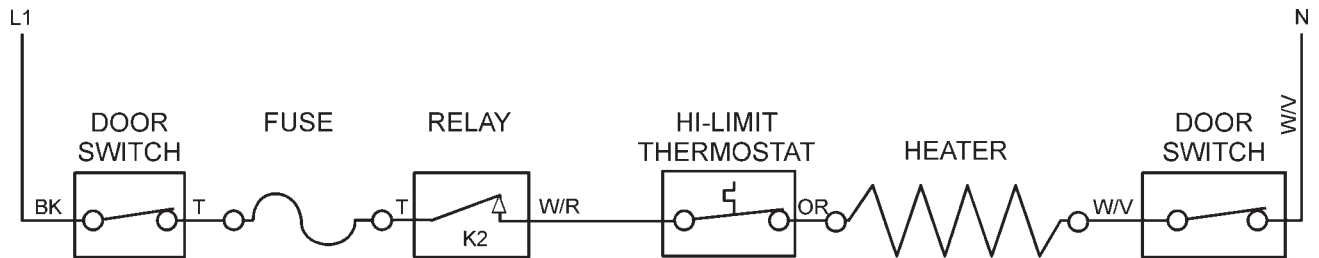

3. Wash

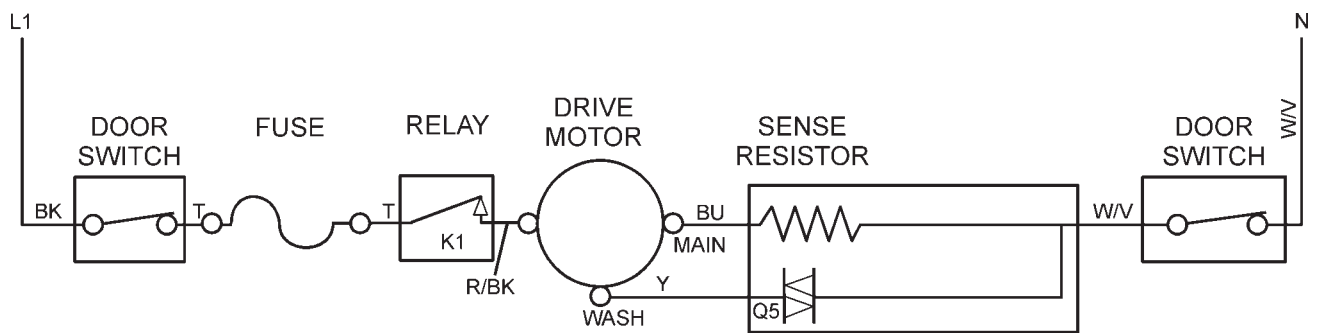

4. Drain

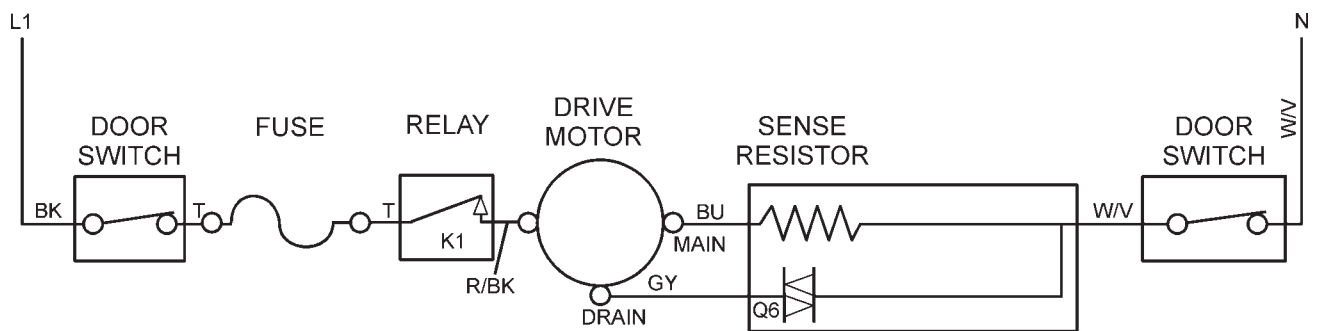

5. Heat Dry

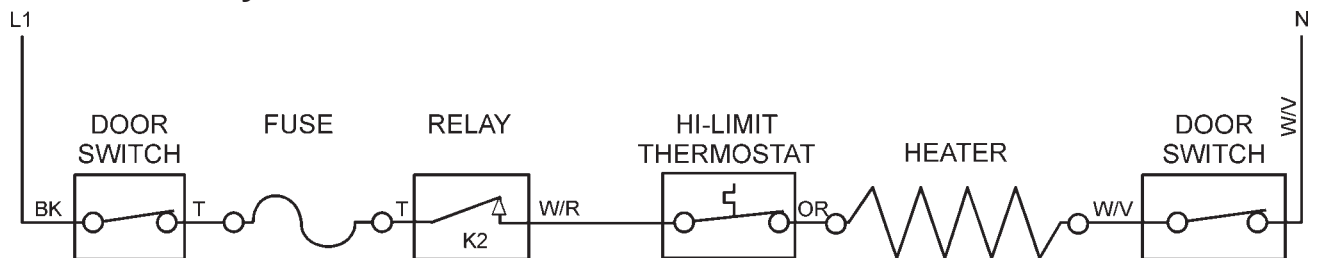

INSTALLING CUSTOM PANEL ACCESSORY KIT

Custom Color Panels:

Black P/N 675775
 White P/N 675776
 Almond P/N 675777

Installation Instructions

In many instances, customers want to integrate the undercounter dishwasher appearance with overall kitchen design by installing panels of wood matching that used in the cabinets. After the two panels - an upper panel and a lower panel - are cut and finished as described below, use the materials in the Dishwasher Custom Panel Accessory Kit to install them by following the installation instructions.

Custom Panel Dimensions

NOTE: A 1/4" thickness (actual 7/32") can be used for wood panels. If using thicker material, edges must be routed to 7/32" as shown in box below.

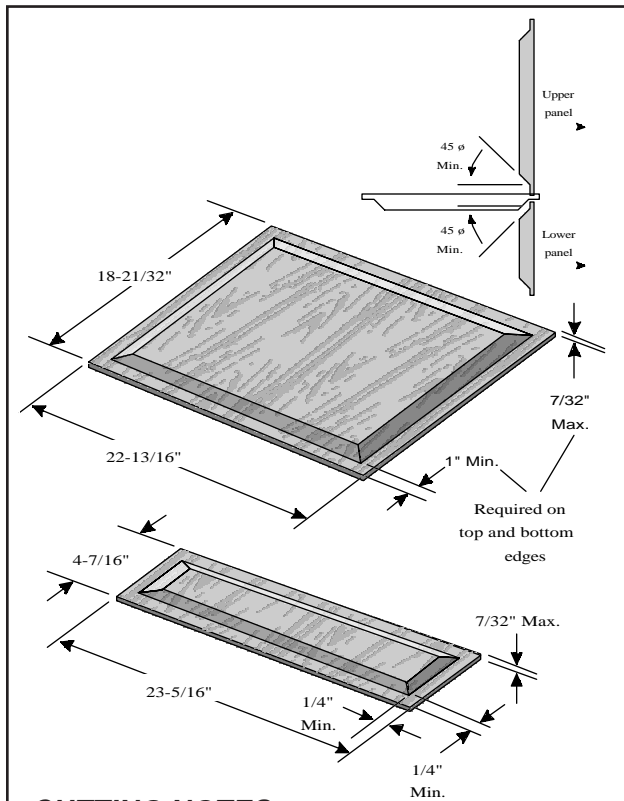

CUTTING NOTES:

1. Custom panel for the door cannot exceed 8 lbs. weight.
2. The upper and lower panels are not the same width.
3. Match wood grain direction with that of adjacent cabinets.
4. Sand panel edges to provide smooth finish.
5. **IMPORTANT:** Use moisture resistant sealer on both sides and all edges of the panels to protect from humidity. Dishwasher is subject to humidity.

Removing Access and Door Panels

1. Loosen but do not remove the two (2) toe panel screws below the access panel. Remove and set aside the two (2) screws above the access panel. (Fig. 4-1)
2. Remove the access panel assembly by sliding it upward to clear the loosened screws. This access panel will be replaced by new a new custom panel assembly. (Fig. 4-1)
3. Remove the two (2) screws from the bottom of the outer door panel. (Fig. 4-1)

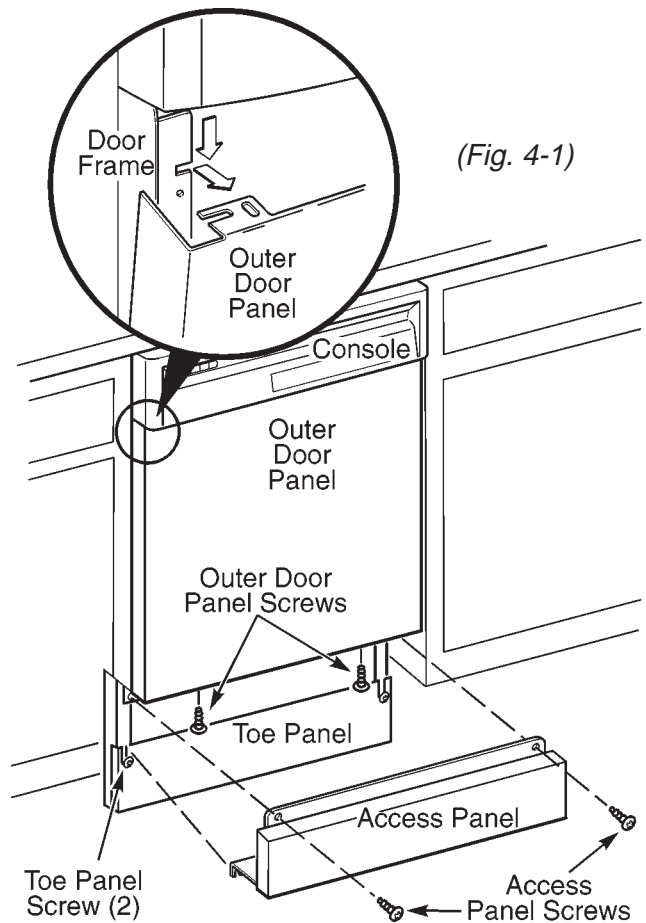

4. Pull the bottom of the outer door panel outward and slide it down approximately $\frac{1}{4}$ " to $\frac{1}{2}$ ". The panel will then be free for removal. (Fig. 4-1, inset) Set the door panel aside; it will be replaced with a new custom panel.
5. Remove the existing door insulation and discard.

Installing Custom Panels

1. Slip the top edge of the mounting strip up under the tabs at the bottom of the door frame so that the strip rests on the lower frame flange. Make sure the strip seats as shown in Figure 4-2. Protruding screws should align with the notches.
2. Using the end of a flat bladed screwdriver, push in on the three (3) tabs to lock the mounting strip into place.

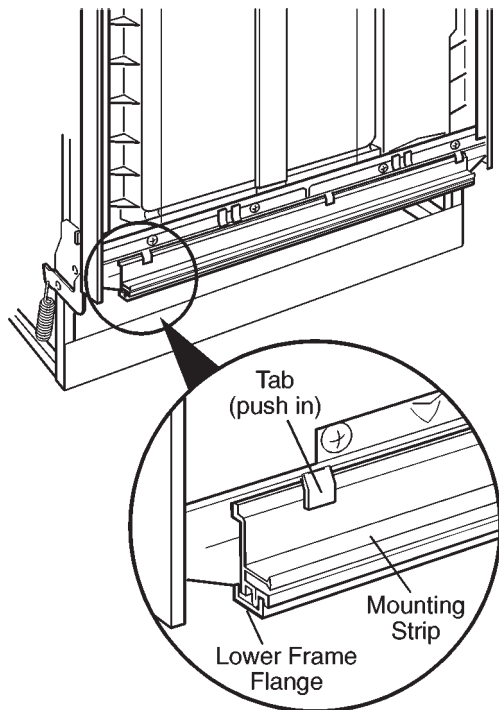

(Fig. 4-2)

3. Install the J-strips by removing the protective strip from the adhesive backing and carefully positioning the J-strips over the left and right door frames. (Fig. 4-3) Peel off the protective film from the outside of the J-strips after installing.

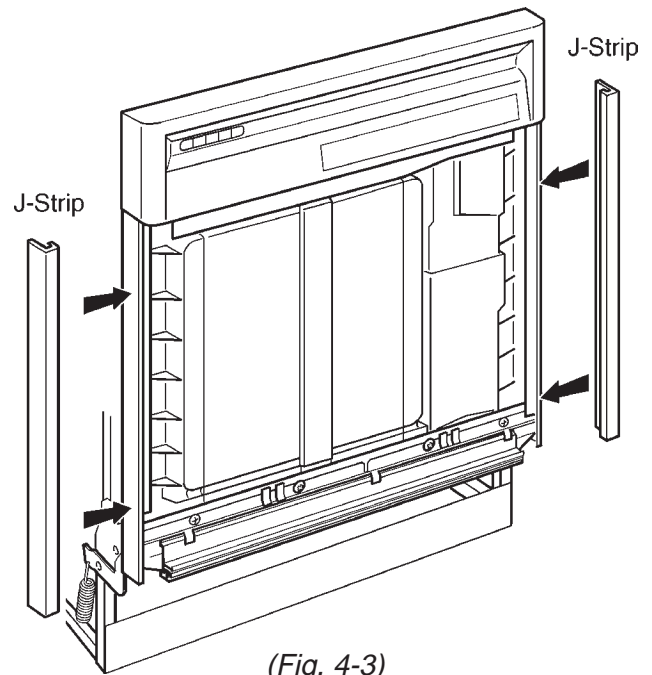

(Fig. 4-3)

4. Tip the custom door panel as shown in Figure 4-4, and insert the top edge into the rear channel at the bottom of the control panel.

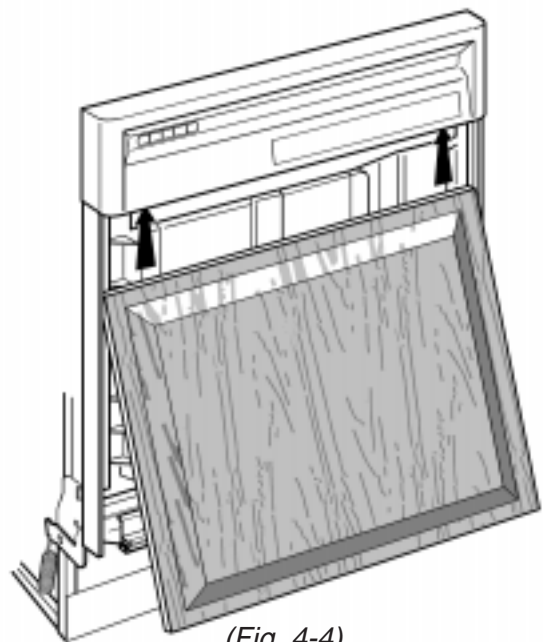

(Fig. 4-4)

5. Straighten the panel and rest the lower edge on top of the mounting strip. Secure the bottom edge of the custom panel by snapping the retainer trim strip into the slot in the mounting strip. (Fig. 4-6)

IMPORTANT

Be sure the door panel is inserted into the rear channel. (Fig. 4-5)

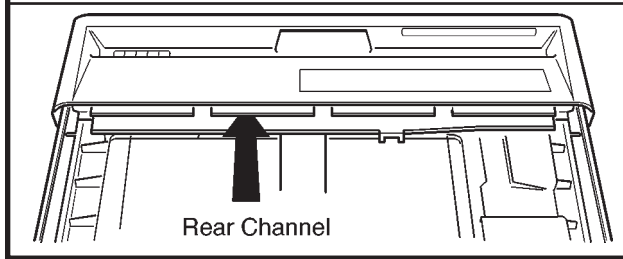

(Fig. 4-5)

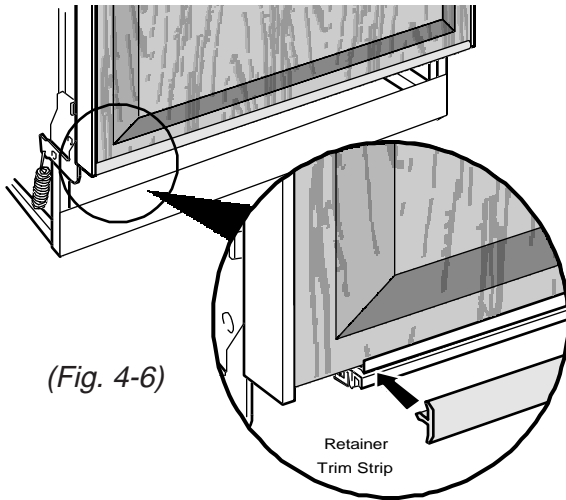

(Fig. 4-6)

- Place the access panel front side down. Install the metal access panel extension into the slot in the access panel by pushing down firmly until the extension snaps into place. (Fig. 4-7)
- Remove the adhesive backing from the access panel insulation and press the insulation firmly into place. (Fig. 4-8)
- Set the access panel upright. Slide the custom panel down into the bottom and side slots. (Fig. 4-9)
- Secure the custom panel by inserting tabs on the panel retainer into the notches along the top back surface of the access panel. Press firmly on the forward edge of the retainer to snap it into place. (Fig. 4-10)
- (Refer to Fig. 4-1 on page 71) Install the access panel assembly to the dishwasher by aligning the slots in the back flange of the extension over the two (2) screw heads protruding from the toe panel. Slide the access panel downward and tighten the screws.

- Reinstall the two (2) access panel screws removed earlier to secure the access panel to the dishwasher. Tighten the right screw first, then the left.

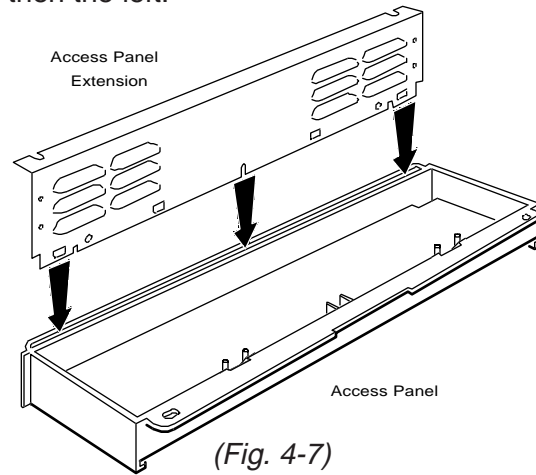

(Fig. 4-7)

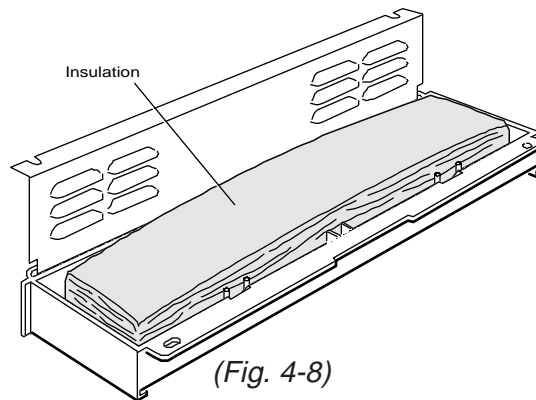

(Fig. 4-8)

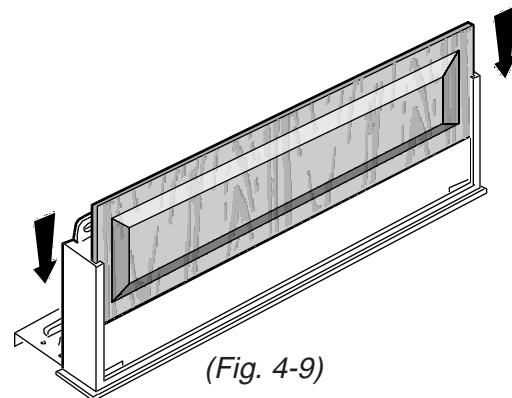

(Fig. 4-9)

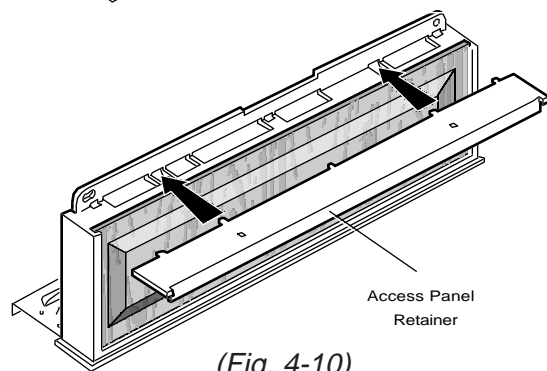

(Fig. 4-10)

Installing Heavy Duty Door Springs

Standard door springs may need to be replaced by heavy duty springs designed to compensate for the increased weight of the door resulting from the installation of custom panels. Perform the following tests to determine whether the heavy duty springs need to be installed.

Heavy Duty Door Spring Kit:

Kit contains two (2) heavy duty door springs and instruction sheet.
Kit P/N 3379643

Door Operation Test:

- Springs should have enough tension to assist in closing the heavier door.
- Door should open evenly, without excessive speed which would cause it to drop abruptly.
- Door should remain fully open without closing by itself.

1. If these operation tests are failed and the dishwasher is already installed under the counter, remove the unit from its installed position.
2. Move the lower hook on each of the standard door springs to the farthest adjustment slot to increase spring tension. Repeat the Door Operation Tests. If the operation tests again fail, the heavy duty springs supplied must be used.
3. Close and lock the dishwasher door. Remove a spring from one side by releasing the lower hook from the adjustment slot first, then disengaging the upper hook from the door hinge bracket. (Fig. 4-11)

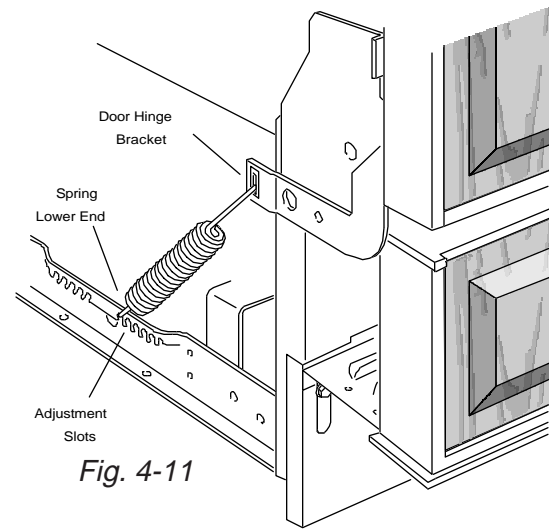

4. Install a heavy duty spring. Insert the smaller hook through the door hinge bracket first, then engage the larger hook in the first notch of the second group of adjustment slots. (Fig. 4-11)
5. Repeat steps 3 and 4 to replace the spring on the opposite side of the door.
6. Open and close the door several times. The door should open and close easily. If the door closes too quickly, decrease the spring tension by moving the lower hook of each spring one (1) notch toward the back of the dishwasher. Springs should be in the same position on the left and right sides. Perform the Door Operation Tests again. Continue to adjust the door spring tension as necessary until the Door Operation Tests confirm proper spring adjustment.
7. Install the dishwasher in the final installed position by following the installation instructions provided with the unit.

INSTALLING THE FLOOR MOUNTING KIT

KIT CONTENTS (P/N 4378968):

- 2 P/N 9743463 Brackets (*Fig. 4-12*)
- 1 P/N 4378974 Instruction Sheet

INSTALLATION INSTRUCTIONS

1. Loosen the two (2) screws below the access panel and remove the two (2) screws above the access panel. (*Fig. 4-13*)
2. Carefully slide the access panel upward and off the two (2) screws below the access panel.
3. Remove the two (2) lower screws securing the toe panel to remove the toe panel from the dishwasher.
4. Position the dishwasher in its final installed position. Refer to the dishwasher installation instructions for the proper installed position.
5. Place the floor mounting brackets so the top of the bracket hooks over the top of the dishwasher side brace towards the back of the unit. (*Fig. 4-14*)
6. Mark the location of the mounting holes on the floor.
7. Remove the dishwasher and drill two (2) holes, on each side of the dishwasher location.
8. Position the dishwasher in its final installed position and install the floor mounting brackets and secure them in place with screws.

Fig. 4-12

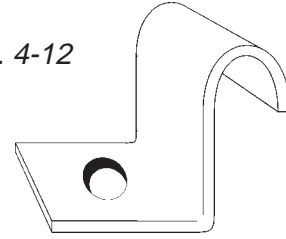

Fig. 4-13

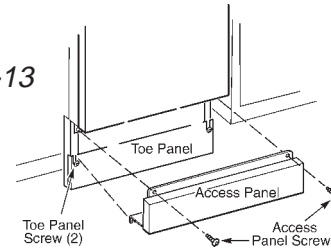
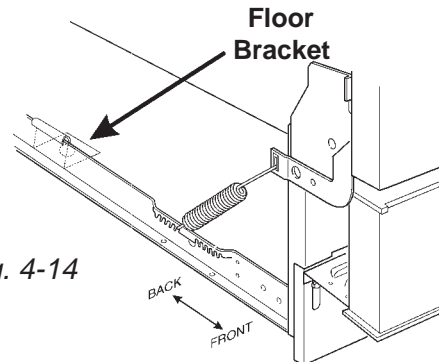

Fig. 4-14



NOTE

The size of the holes drilled in the floor will depend on the size of the hardware (screws) being used for the installation.

9. Reinstall the dishwasher by following the installation instructions provided with the unit.
10. Install the toe panel and the access panel by reversing steps 1 through 3.

WHIRLPOOL

Dishwasher Warranty

LENGTH OR WARRANTY	WHIRLPOOL WILL PAY FOR
FULL ONE-YEAR WARRANTY FROM DATE OF PURCHASE	FSP™ replacement parts and repair labor to current defects in materials or workmanship. Service must be provided by an authorized Whirlpool service company.
LIMITED ONE-YEAR WARRANTY SECOND YEAR FROM DATE OF PURCHASE	FSP™ replacement parts for any part of the POWER CLEAN® filter module washing system if defective in materials or workmanship. These parts are shown on page 29.
LIMITED FOUR-YEAR WARRANTY SECOND THROUGH FIFTH YEAR FROM DATE OF PURCHASE	FSP™ replacement parts for Electronic Control system if defective in materials or workmanship. For models with dishracks that are oyster-colored, FSP™ replacement parts for the top and/or bottom dishracks if they rust due to defective materials or workmanship.
FULL TWENTY-YEAR WARRANTY FROM DATE OF PURCHASE	FSP™ replacement parts and repair labor for the DURAPERM® tub and/or inner door should they fail to contain water due to defective materials or workmanship. Service must be provided by an authorized Whirlpool service company.
WHIRLPOOL WILL NOT PAY FOR	
<p>A. Service calls to:</p> <ol style="list-style-type: none"> 1. Correct the installation of the dishwasher. 2. Instruct you how to use the dishwasher. 3. Replace house fuses or correct house wiring or plumbing. <p>B. Repairs when dishwasher is used in other than normal, single-family household use.</p> <p>C. Pickup and delivery. This product is designed to be repaired in the home.</p> <p>D. Damage to dishwasher caused by accident, misuse, fire, flood, acts of God or use of products not approved by Whirlpool.</p> <p>E. Any labor costs during limited warranty.</p> <p>F. Repairs to parts or systems resulting from unauthorized modifications made to the appliance.</p> <p>G. In Canada, travel or transportation expenses for customers who reside in remote areas.</p>	

WHIRLPOOL CORPORATION AND INGLIS LIMITED SHALL NOT BE LIABLE UNDER THIS WARRANTY FOR INCIDENTAL OR CONSEQUENTIAL DAMAGES.

Some states and provinces do not allow the exclusion or limitation of incidental or consequential damages, so this exclusion or limitation may not apply to you. This warranty gives you specific legal rights, and you may also have other rights which vary from state to state or province to province.

Outside the United States and Canada, a different warranty may apply. For details, please contact your authorized Whirlpool dealer.

In you need service, first see the “Troubleshooting” section of this book. After checking “Troubleshooting,” additional help is available by calling our Consumer Assistance Center telephone number, **1-800-253-1301**, from anywhere in the U.S.A. In Canada, you may call your Inglis Limited Appliance Service Branch.

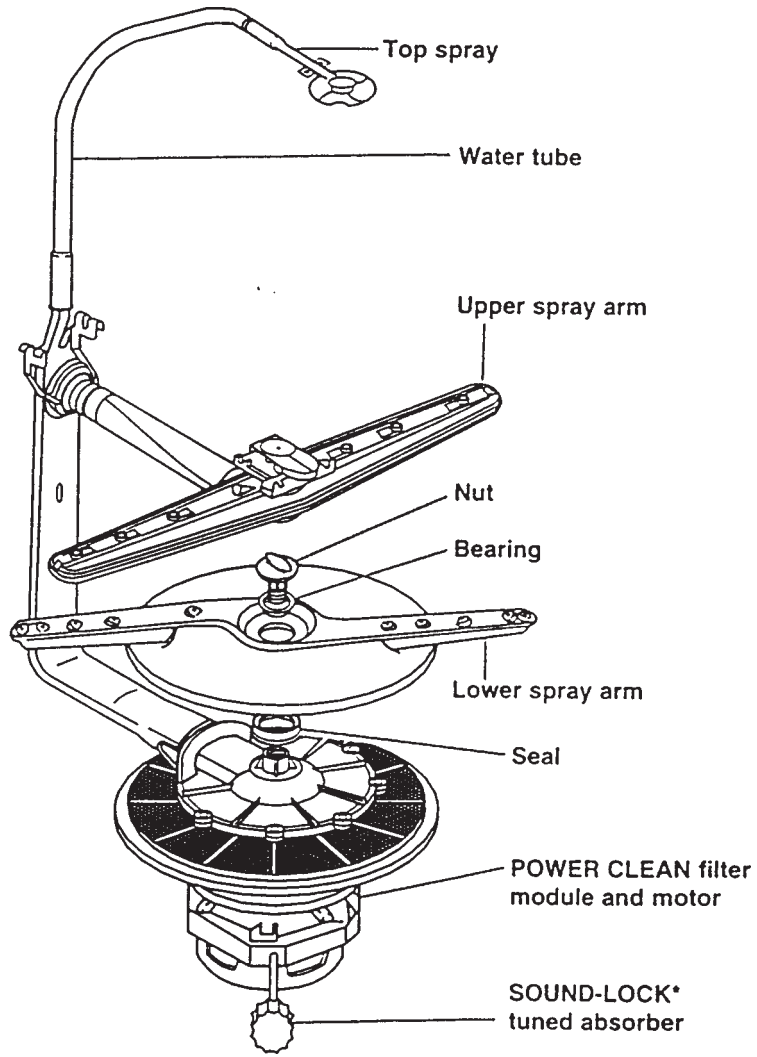

SERIAL PLATE LOCATOR

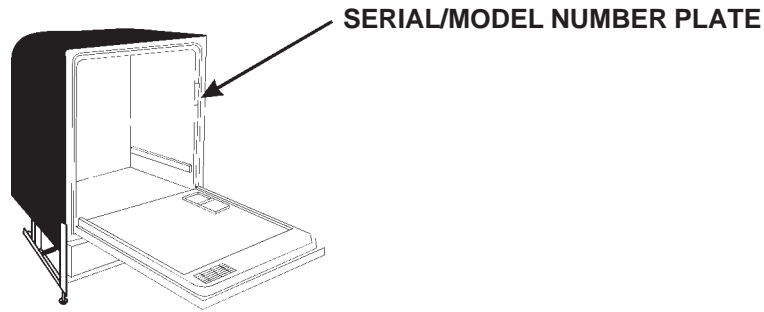

SERIAL NUMBER DESIGNATOR

SERIAL NUMBER	F	G	18	70352
MANUFACTURING SITE F = Findlay, OH				
YEAR OF MANUFACTURE G = 1997 H = 1998				
WEEK OF MANUFACTURE 18 = 18th Week				
PRODUCT SEQUENCE NUMBER				

MODEL NUMBER DESIGNATOR

MANUFACTURING NUMBER	D	U	9	20	PF	G	N	0
MARKETING CHANNEL (if present)								
PRODUCT GROUP D = Dishwasher G = Gold Line Dishwasher								
PRODUCT IDENTIFICATION P = Portable U = Undercounter								
FEATURES 4 = Advertising Model 8 = Soil Settler 9 = Power Clean								
FEATURES 00 = Rocker Switch (Soil Settler) or 5 Push Button (Power Clean) 20 = 7 Push Button 40 = 4 Push Button (Soil Settler) or 9 Push Button (Power Clean) 60 = 10 Push Button 80 = 11 Push Button								
FEATURES DW = Durawash/Soil Settler PF = Power Filter/Tower Feed SC = Power Filter/Internal Feed								
YEAR OF INTRODUCTION G = 1998								
COLOR CODE								
ENGINEERING CHANGE (Numeric)								

CONTACT INFORMATION

For Product Specifications and Warranty Information Sources:

1-800-874-4698

For Technical Assistance:

1-800-253-2870

For Service Manuals and other Service Literature:

1-800-851-4605

For Service Replacement Parts:

1-800-259-7278

For Safety Related Information:

1-800-541-5746

