

Motor-drive mechanism, type BUL

Technical guide



ABB

This Technical Guide has been produced to allow transformer manufacturers, and their designers and engineers, access to all the technical information required to assist them in their selection of the appropriate on-load tap-changer and motor-drive mechanism. The guide should be used in conjunction with the *Selection Guide* and the *Design Guides*, to allow the optimum selection to be made.

The technical information pertaining to on-load tap-changers and motor-drive mechanisms manufactured by ABB has been divided and is contained in separate documents, with one document for each type.

The information provided in this document is intended to be general and does not cover all possible applications. Any specific application not covered should be referred directly to ABB, or its authorized representative.

ABB makes no warranty or representation and assumes no liability for the accuracy of the information in this document or for the use of such information. All information in this document is subject to change without notice.

Table of Contents

<p>General Information _____ 4</p> <p style="padding-left: 20px;">Applications _____ 4</p> <p style="padding-left: 20px;">Design _____ 4</p> <p style="padding-left: 20px;">Cabinet _____ 4</p> <p style="padding-left: 20px;">Tropical Version _____ 4</p> <p style="padding-left: 20px;">Type Tests _____ 4</p> <p style="padding-left: 20px;">Ambient Air Temperature _____ 6</p> <p style="padding-left: 20px;">Connection of Motor-Drive Mechanism to Tap-Changer _____ 6</p> <p style="padding-left: 20px;">Rating Plate _____ 7</p> <p>Mechanical Arrangements _____ 8</p> <p style="padding-left: 20px;">Driving Arrangement _____ 8</p> <p style="padding-left: 20px;">Hand Crank _____ 8</p> <p style="padding-left: 20px;">"One-Turn" Shaft _____ 8</p> <p style="padding-left: 20px;">Position Indicator _____ 8</p> <p style="padding-left: 20px;">Mechanical End Stops _____ 8</p> <p style="padding-left: 20px;">Electrical End Stops _____ 8</p> <p style="padding-left: 20px;">Brake _____ 8</p> <p style="padding-left: 20px;">Indicator Flag _____ 9</p> <p style="padding-left: 20px;">Operation Counter _____ 9</p> <p style="padding-left: 20px;">Maintaining, Interlocking and Auxiliary Contacts _____ 9</p> <p style="padding-left: 20px;">Multi Position Switches _____ 9</p> <p style="padding-left: 40px;">Position Transmitter, Potentiometer _____ 9</p>	<p style="padding-left: 40px;">Continuation Contact _____ 9</p> <p style="padding-left: 40px;">Auxiliary Contacts _____ 9</p> <p style="padding-left: 20px;">Driving Mechanism Equipment _____ 10</p> <p style="padding-left: 20px;">Exploded Views and Photos _____ 11</p> <p>Principles of Operation _____ 14</p> <p style="padding-left: 20px;">Raise-Operation with Local Control _____ 14</p> <p style="padding-left: 20px;">Lower-Operation with Local Control _____ 14</p> <p style="padding-left: 20px;">Through Positions _____ 14</p> <p style="padding-left: 20px;">Remote Control _____ 14</p> <p style="padding-left: 20px;">Circuit Diagram _____ 15</p> <p style="padding-left: 20px;">Contact Timing Diagram _____ 16</p> <p>Standard Version _____ 17</p> <p style="padding-left: 20px;">Control _____ 17</p> <p style="padding-left: 20px;">Protection _____ 17</p> <p style="padding-left: 20px;">Indication _____ 17</p> <p style="padding-left: 20px;">Wiring _____ 17</p> <p style="padding-left: 20px;">Maintenance _____ 17</p> <p style="padding-left: 20px;">Design Options _____ 17</p> <p style="padding-left: 20px;">Multi-Position Switches _____ 17</p> <p style="padding-left: 20px;">Technical Data _____ 18</p> <p style="padding-left: 20px;">Dimensions _____ 19</p> <p style="padding-left: 20px;">Weight _____ 19</p>
--	---

General Information

Applications

The BUL Motor-Drive Mechanism is designed for outdoor operation of the On-Load Tap-Changers and large De-energized Tap-Changers listed below.

Tap-Changer	Type of Connection
UBB	For all connections
UCG	Star point or single-phase
UCL	Star point or single-phase

Design

The Motor-Drive Mechanism is normally mounted on the side of the transformer tank and by means of drive shafts and bevel gears connected to the Tap-Changer. The shaft system is described in the *Technical Guide* for each type of Tap-Changer.

The BUL contains all the necessary equipment for operation of the Tap-Changer. Special equipment can be supplied in order to fulfil customers requests. Paralleling and voltage regulation systems can also be supplied to supplement the Motor-Drive Mechanism and Tap-Changer.

Cabinet

The cabinet is manufactured of welded sheet steel and is in standard version hot dip galvanized. On request it can instead be painted with a white primer or a complete painting system, primer and top coat, suitable for outdoor use.

The front door is formed as a cap in order to give better access to the internal parts. The door can be hinged on either the left or the right hand side. Provision is made for eventual padlocking. The door is sealed with rubber gasket and the window is glued to the door.

The Motor-Drive Mechanism is mounted to the transformer tank with four screws or studs, M12 or ½", through the backside of the cabinet. Those are screwed from the inside of the cabinet and also going through the frame for the mechanism. The bottom has a flange opening for cable connection, size FL 21, see page 19. When delivered the opening is covered with a 5 mm thick light-alloy cover.

The cabinet has two vents. Filters prevents insects and dust from entering. In order to prevent condensation inside the cabinet a 50 W heater is supplied which is permanently connected. With this heater the Motor-Drive Mechanism functions satisfactorily down to -40 °C (-40 °F). For temperatures below -40 °C or on customers request an additional 100 W heater controlled by a thermostat can be supplied. This extra heater can also on request be supplied with a switch for manual disconnection.

The tightness of the cabinet has been type tested for protection class IP 56 according to IEC 529 (protected against dust and powerful water jets).

The handlamp is automatically switched on when the door is opened.

On request the inside of the cabinet can have a 3 mm thick layer of anti-condensation paint.

Tropical Version

The Motor-Drive Mechanism can be equipped to meet the requirements for humid tropical climate and desert conditions. Anti-condensation painting inside the cabinet and screens to shade from direct sun radiation can be supplied.

Type Tests

The BUL Motor-Drive Mechanism fulfills the requirements of IEC Standard 214, 1989-07, and has been type tested according to clause 12.

The position numbers below refers to page 10.



Fig. 1. Motor-Drive Mechanism type BUL

L036702

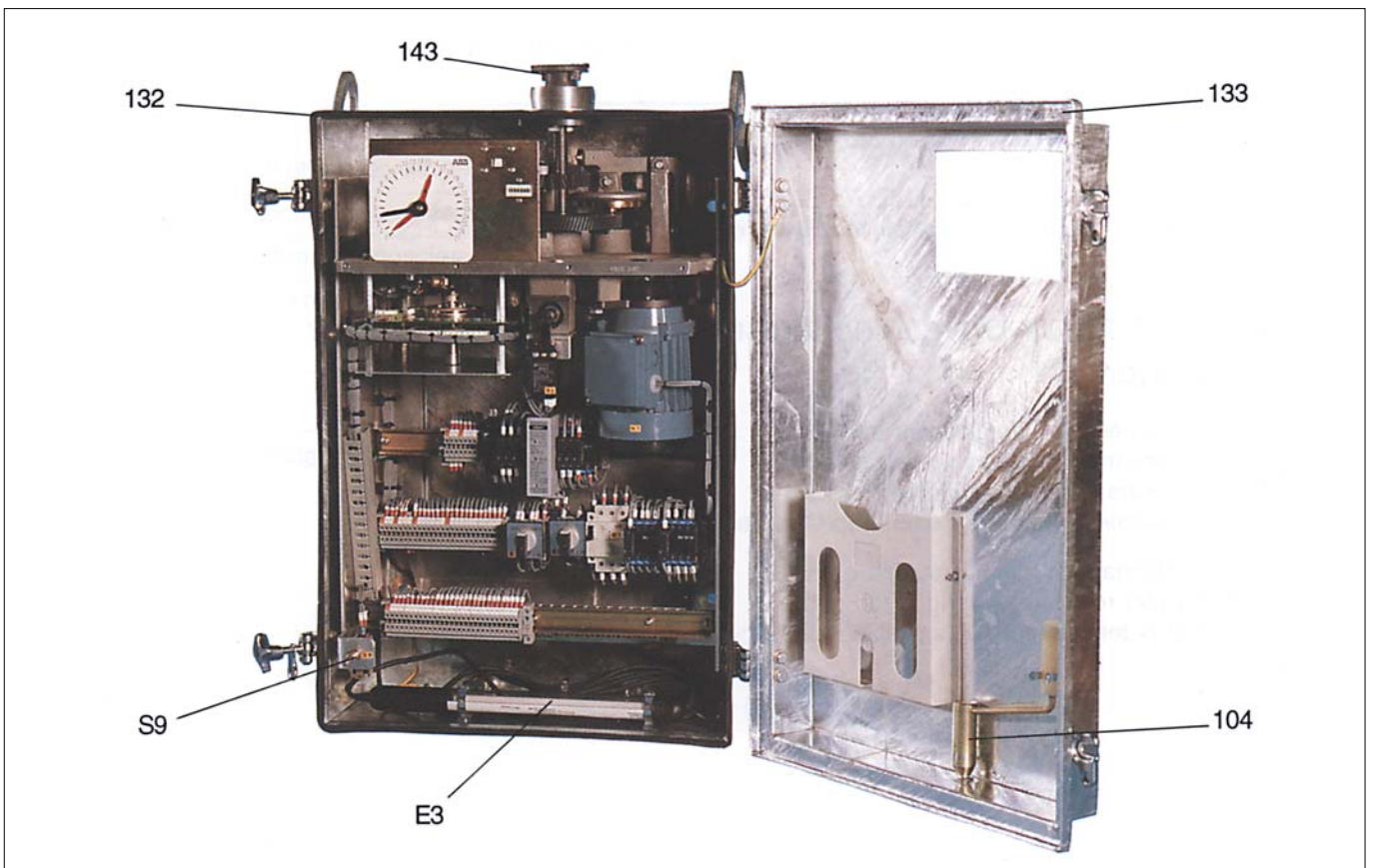

Fig. 2. Motor-Drive Mechanism type BUL

L036703

Ambient Air Temperature

The ambient air temperature requirements for the Motor-Drive Mechanism are shown in fig. 3. The normal operating range is between $-40\text{ }^{\circ}\text{C}$ and $+60\text{ }^{\circ}\text{C}$.

The Motor-Drive Mechanism has been type tested at ambient air temperatures of $-40\text{ }^{\circ}\text{C}$ and $+70\text{ }^{\circ}\text{C}$.

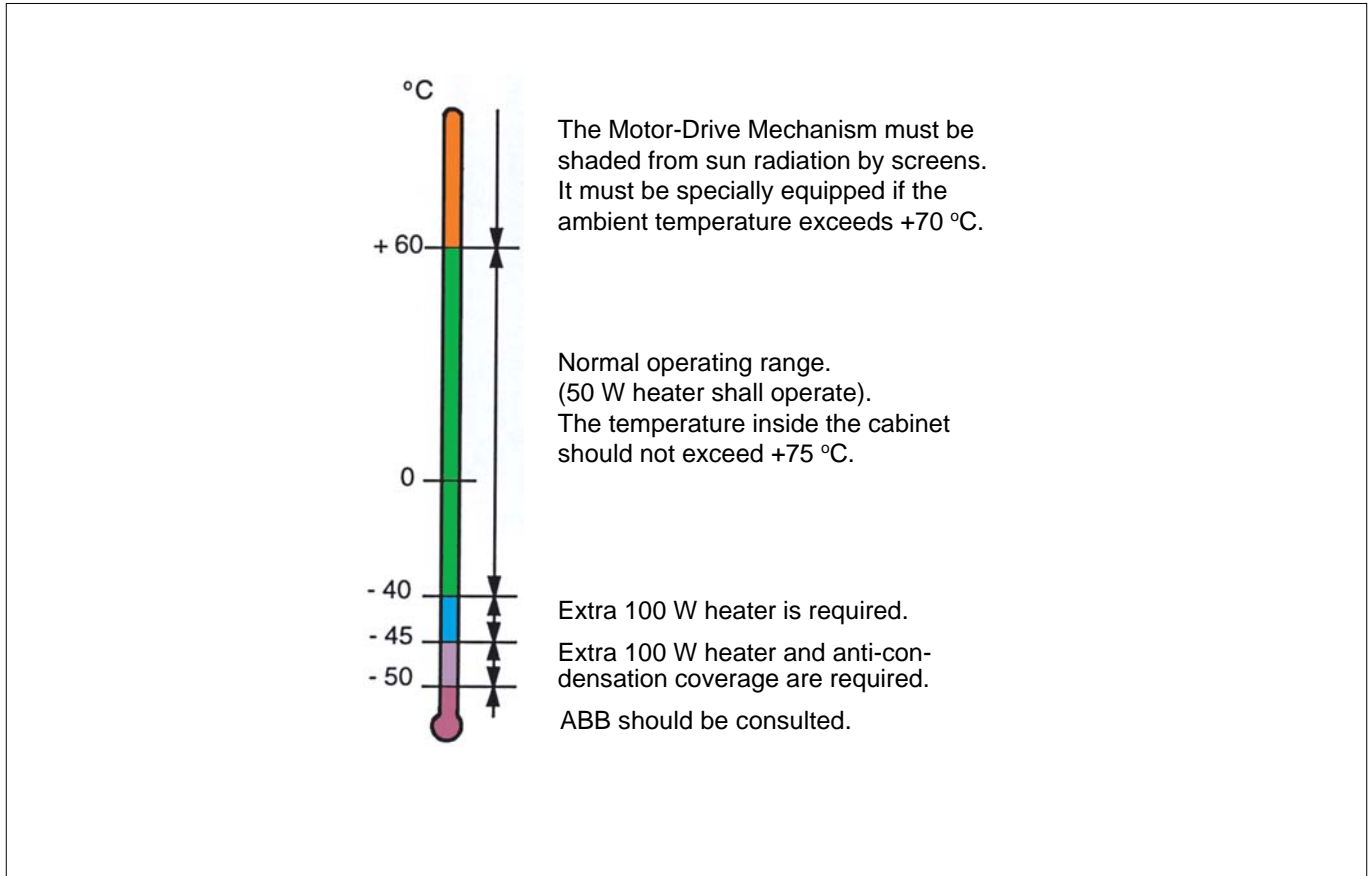

Fig. 3. Motor-Drive Mechanism ambient air temperature

Connection of Motor-Drive Mechanism to Tap-Changers

The connection between the Tap-Changer and the Motor-Drive Mechanism is made by means of drive shafts and bevel gears. This external shaft system is described in the *Technical Guide* for each Tap-Changer.

The Motor-Drive Mechanism has the outgoing shaft going through a water resistant bearing in top of the cabinet. The shaft is terminated by a multiple hole coupling half.

Rating Plate

The rating plate shows data for both Tap-Changer and Motor-Drive Mechanism and is placed on the front door of the Motor-Drive Mechanism.

ABB Power Technology Products AB		Ludvika Sweden		CE	MADE IN SWEDEN
On-load tap changer			Motor-drive mechanism		
Type UBBRN 350/400			Type BUL		
Number of pos. 27	No. 8415 362		Motor supply	3~50Hz 380-420	V
201 A	Stepvoltage	830 V 50 Hz	Contactors	50Hz 220-230	V
Transition resistance		4.1 ohm	Position transmitter	AC 220-240	V
Estimated contact life		500 000	Heating element	208-240	V
operations					
Standards IEC 214 (1989-07)			Year of manufacture 2001		
Maintenance after 100000 operations or at least every 5 year, whichever comes first. Inspection once a year.					
<p>CAUTION</p> <p>The motor-drive mechanism must be protected against condensation. Energize the heater when power is available. When not, put drying agent inside the motor drive cabinet and seal the vents.</p>					

Fig. 4. Example of Rating Plate

Mechanical Arrangements

(See Fig. 5–8 and legend on page 10)

Driving Arrangement

The drive mechanism motor M1 with its pulley 121 drives, with ratio 4.5:1, pulley 122 on the intermediate shaft 140 via a toothed belt 101. On the intermediate shaft is a pinion with helical teeth 141 which with ratio 5:1 drives the helical gear 142 on the outgoing shaft 103. The outgoing shaft is then via a multiple hole coupling 143 directly connected to the shaft system of the Tap-Changer. The outgoing shaft makes 5 revolutions per operation.

The Mechanism is assembled on a support of casted aluminium, 144.

Hand Crank

The mechanism can be manually operated by means of a hand crank 104. The hand crank is put on the crank shaft 105, which through the bevel pinion 123, with ratio 3:1, drives the bevel gear 124 on the outgoing shaft. Direction of operation is clockwise for a raise operation and 15 revolutions are needed per operation. This is also shown on a sign placed on the transparent protection screen.

When the hand crank is put onto the crank shaft, the interlocking switch S5 breaks the operating circuit of the motor thus preventing electrical operation.

With manual operation the mechanism must be put into an exact position. If the mechanism is left between two positions or in a through position, when it is electrically supplied, the mechanism starts directly on removal of the hand crank.

"One-Turn" Shaft

A helical pinion 106 on the outgoing shaft drives, with ratio 5:1, the helical gear 102 placed on the "one-turn" shaft 107. This shaft drives two Geneva wheels 125 and 126 with the ratio 36:1. The driving pin 108 for the upper Geneva wheel 125 shall in the normal position be in the slot of the Geneva wheel whereas the lower Geneva wheel 126 is locked by the circumference of the "one-turn" shaft.

Position Indicator

The lower Geneva wheel 126 is pinned to the Geneva shaft 145, which through a bevel gear 109, with ratio 1:1 operates the position indicator shaft 146, on which the position indicator pointer 110 is assembled. On the position indicator shaft is also assembled drag-hands

for indication of the maximum and minimum positions. Those drag-hands can be restored manually. The position indicator is visible through a window in the door.

Mechanical End Stops

The upper Geneva wheel 125 is supported by the Geneva shaft and turns independent of the shaft controlled by the upper driving pin 108 on the "one-turn" shaft. On the Geneva wheel two screws 136 are fitted which at the end positions operates the mechanical end stop 113 via an arm 147. Extra screws could be placed in between the screws 136 if a decreased tap-change range is desired.

After the end position has been reached the mechanical end stop is pressed out in the way for a knob 148 under the helical gear 142 which prevents the outgoing shaft from further movement in that direction.

When the mechanism is returned to the end position by manual cranking, the mechanical end stop will be pressed back by springs, which also keeps it positioned in all normal tap change positions.

The breakpin 114 in the bevel pinion 123 on the crank shaft 105 prevents overloading of the end stops by hand cranking.

Electrical End Stops

On the lower end of the shaft for arm 147 a cam curve 149 is mounted. When the mechanism is in an end position this cam curve operates limit switches S6 and S7 which breaks the operating circuit of the motor and two phases of the motor supply. Electrical operation beyond the end positions is thus impossible.

In case of faulty limit switches the motor will be stopped by the mechanical end stop and is dis-connected when the thermal over-current protection trips the motor protective switch Q1 see circuit diagram on page 15.

Brake

On the upper end of the "one-turn" shaft 107 is a cam disc 128 which operates a brake 117 working on a brake disc 118 on top of the intermediate shaft 140. This brake makes sure that the Motor-Drive Mechanism stops in the correct position after each tap change. The brake can be adjusted by a screw 150 which is pressing on the spring 151 that closes the brake.

Indicator Flag

The indicator flag is placed in the end of the indicator arm 116 which is operated by the cam disc 128. The flag is visible through a slot in the front plate 119. When the mechanism is in position the white part of the flag is visible and during a tap-change the red part is shown.

The indicator flag is also visible through the window in the door.

Operation Counter

A seven digit mechanical operation counter 120 is also operated by the indicator arm 116. The counter is not possible to reset and will register the total number of operations carried out by the Motor-Drive Mechanism. The counter is mounted on the front plate 119 and is also visible through the window in the door.

Maintaining, Interlocking and Auxiliary Contacts

At the lower end of the "one-turn" shaft is another cam disc 115 which via a lever 129 operates two sets of contacts, S3 and S4. S3 is affected during raise operations and S4 during lower operations.

The cam disc does not release the lever and the contacts before the tap-change operation is completed. Before the start impulse disappears the maintaining contact 33-34, see Fig. 9, closes another feeding to the contactor K2 or K3 and thus keep the motor running until the operation is completed. After a possible interruption of the supply voltage during an operation this contact will also make the operation completed when the supply voltage returns.

The interlocking contacts 41-42, see Fig. 9, opens the circuit to the contactor for operation in the opposite direction. Thus unintentional change of direction is prevented. This contact also prevents operation in case the motor rotation should be wrong due to incorrect phase sequence.

The contacts 13-14 and 21-22, see Fig. 9, are auxiliary contacts. They can be used for signal to the control room or remote interlocking during tap change operation.

Multi-Position Switches

The lower end of the Geneva shaft 145 is via a coupling 111 connected to the multi position switch shaft 112. The multi position switch therefore moves 1/36 of a turn, 10°, per tap change step.

The multi position switch 127 is assembled of up to 5 different printed circuit cards 160. Each card has a contact arm 161. A slot in the multi position switch shaft 112 transfers the turning to a knob on the contact arm. The contacts 162 on the arm are solid silver rivets and the contact surfaces 163 on the circuit cards are gold plated. Before delivery all cards are insulation tested with 2 kV to earth.

The contacts on each card are protected against dust by a transparent cover 164.

Position Transmitter (S14), Potentiometer

As standard the contact device is supplied with a potentiometer transmitter which has 10 ohm, 0.6 W, resistances between each position. Other resistances can be supplied on request.

On request a suitable measuring amplifier for moving-coil instrument can be supplied. Also the instrument for remote position indication in the control room can be included on request.

Continuation Contact (S15)

In cases when the Tap-Changer has two or more positions with the same voltage a continuation contact is supplied. Only one of the positions is the service position, and the others are through positions which are passed automatically at an electric operation. See description of operation on page 14.

Auxiliary Contacts

Auxiliary contacts, break before make or make before break as well as odd-even switches for parallel control can be supplied on request.

Driving Mechanism Equipment

See Fig. 1, 2 and 5–8.

E1	Anti-condensation heater	120	Operation counter
E3	Cabinet light	121	Pulley
K1	Step-by-step relay	122	Pulley
K2	Contactora, Raise	123	Bevel pinion
K3	Contactora, Lower	124	Bevel gear
M1	Motor	125	Geneva wheel, upper
Q1	Motor protective switch	126	Geneva wheel, lower
S1	Control selector switch, Local-0-Remote	127	Multi position switches
S2	Control switch, Lower-0-Raise	128	Cam disc
S3	Maintaining, interlocking and auxiliary contact, Raise	129	Lever for maintaining contact
S4	Maintaining, interlocking and auxiliary contact, Lower	130	Rating plate
S5	Interlocking switch, open when hand crank is fitted	131	Hinges
S6	Limit switch, Upper tap position	132	Motor-drive mechanism cabinet
S7	Limit switch, Lower tap position	133	Door
S9	Door operated switch	134	Hand knob
S14	Position transmitter, potentiometer	135	Air vent
S15	Continuation contact	136	Screw for end stop
X1-17	Terminals	140	Intermediate shaft
U1	Measuring amplifier	141	Helical pinion
101	Toothed belt	142	Helical gear
102	Helical gear	143	Multiple hole coupling half
103	Outgoing shaft	144	Support
104	Hand crank	145	Geneva shaft
105	Crank shaft	146	Position indicator shaft
106	Helical pinion	147	Arm for end stop
107	"One-turn" shaft	148	Knob for mechanical end stop
108	Geneva wheel driving pin	149	Cam curve
109	Bevel gear	150	Screw for adjustment of brake
110	Mechanical position indicator	151	Spring for brake
111	Coupling	160	Printed circuit card
112	Multi position switch shaft	161	Contact arm
113	Mechanical end stop	162	Silver rivet contact
114	Breakpin	163	Gold plated contact surface
115	Cam disc for maintaining contact	164	Transparent cover
116	Indicator arm		
117	Brake		
118	Brake disc		
119	Front plate		

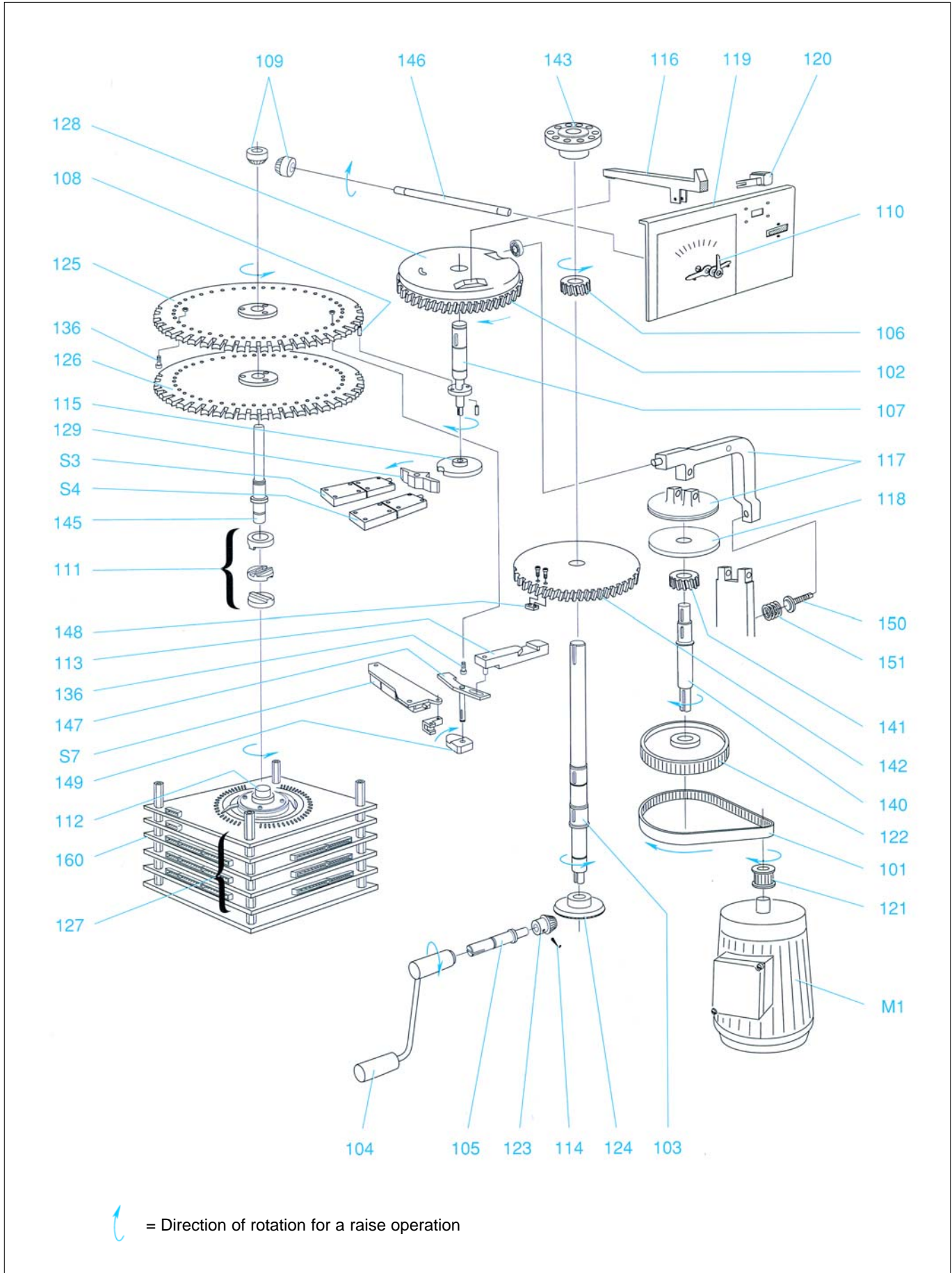

Fig. 5. Motor-Drive Mechanism type BUL

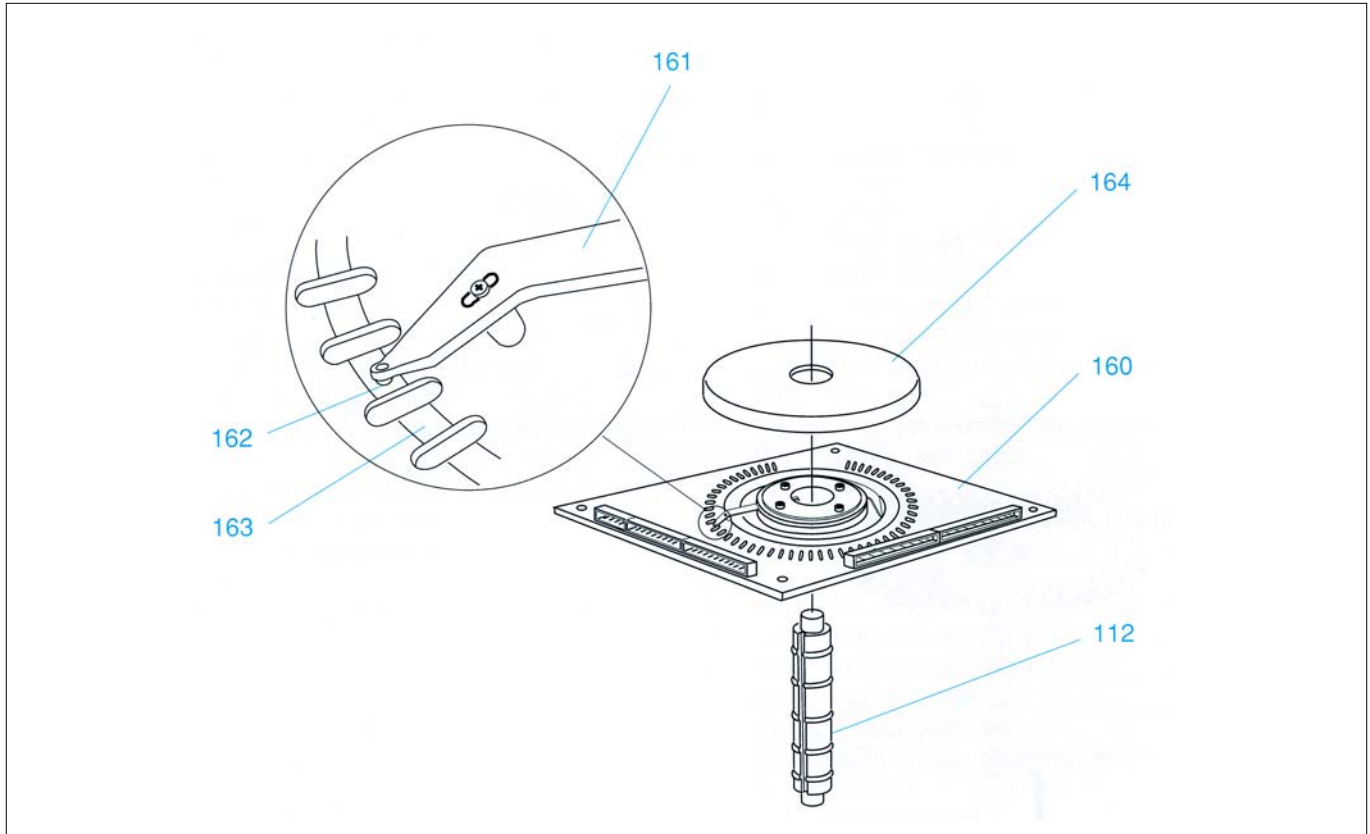

Fig. 6.

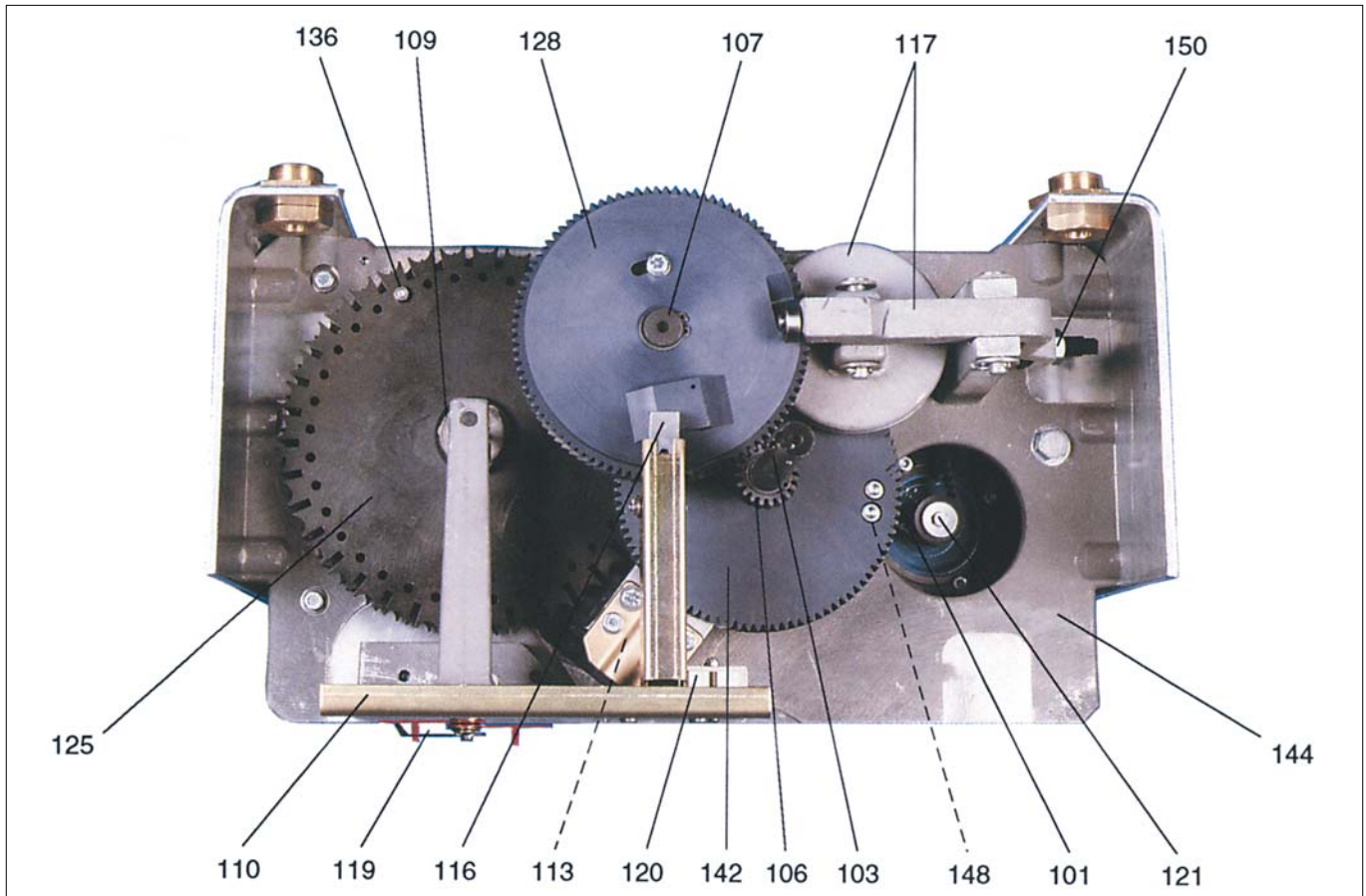

Fig. 7.

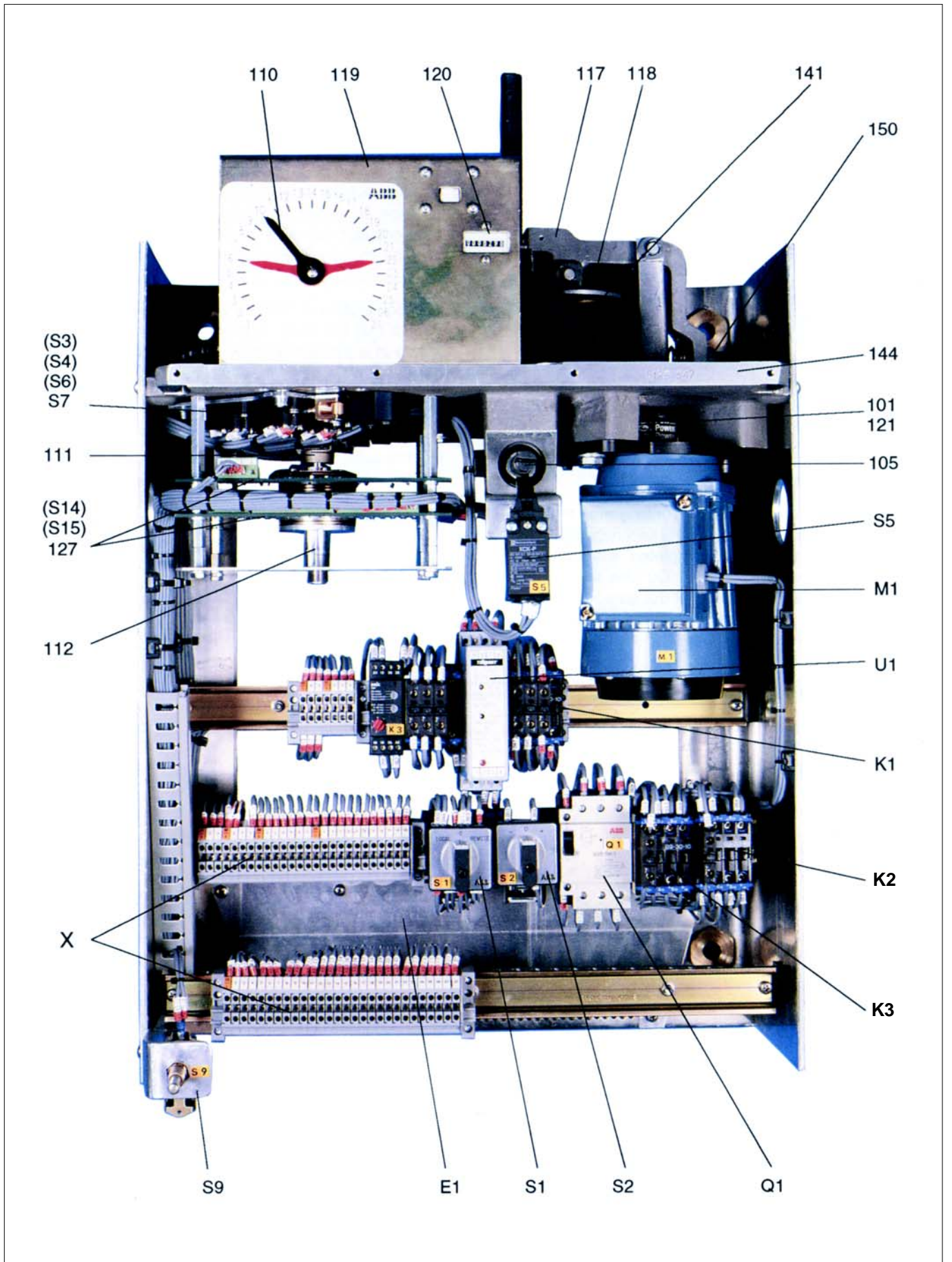

Fig. 8.

Principles of Operation

Circuit Diagram for AC Supply, see Fig. 9.

The supplies for motor, control circuits and heater are connected to their respective terminal blocks according to the instructions on the diagram.

Raise-Operation with Local Control

When switch S1 is set in position "Local" the mechanism can be operated by control switch S2. For a raise operation the procedure is as follows:

Motor contactor K2 is energized, the contactor closes the motor phases, the motor starts and drives the mechanism in the raise-direction. After about 0.2 seconds the brake is released and after about 0.4 seconds the maintaining contact S3: 33-34 closes and take over the feeding of contactor K2 when control switch S2 is released.

The switching in the On-Load Tap-Changer takes place after about 3 seconds.

The driving mechanism keeps on rolling until the cycle is completed, which takes about 5 seconds. About 0.2 seconds before the cycle is completed, the maintaining contact S3 is released, contactor K2 falls and the feeding of the motor is interrupted. At the same time the brake is engaged and the mechanism will stop in the new position.

Lower-Operation with Local Control

A similar cycle is obtained, but in the lower direction, when the control switch S2 is switched to lower position and contactor K3 is engaged.

Through Positions

A so called "Through position", is a position the Tap-Changer has to pass without changing the ratio of the transformer. These positions are passed automatically. The continuation contact S15 bridges the maintaining contacts S3:33-34 and S4:33-34 via auxiliary contacts on raise contactor K2 at through positions. In this way the contactor K2 raise, or K3 lower, is kept energized and the motor will automatically make another operation.

The connection of S15 to auxiliary contacts on K2, means that the drive, in the event of a control supply failure in a through position, always moves to a lower normal service position, when the voltage returns.

Remote Control

Control selector switch S1 is placed in the "Remote" position. The control supply for the remote pushbuttons or regulating relay is then received from a terminal in the Motor-Drive Mechanism Cabinet. Incoming control circuits for raise and lower impulses should be connected to other terminals as shown in the diagram. Local operation is not possible when switch S1 is in the "Remote" position and remote operation is not possible in the "Local" position.

Step-by-Step-Operation

Step-by-step relay (K1) connected so that only one tap change operation is obtained each time the raise/lower switch is operated.

Protection against Running-Through

A relay (K6) stopping the motor-drive mechanism in case of a failure of the step-by-step control circuit which would cause a running-through of the motor-drive mechanism. The relay energizes the trip coil in the protective motor switch (Q1).

Contact Timing

The contact timing diagram, Fig. 10, shows the contact sequences for one change of tap position for raise and lower directions.

Circuit Diagram

The diagram shows the mechanism in middle position.

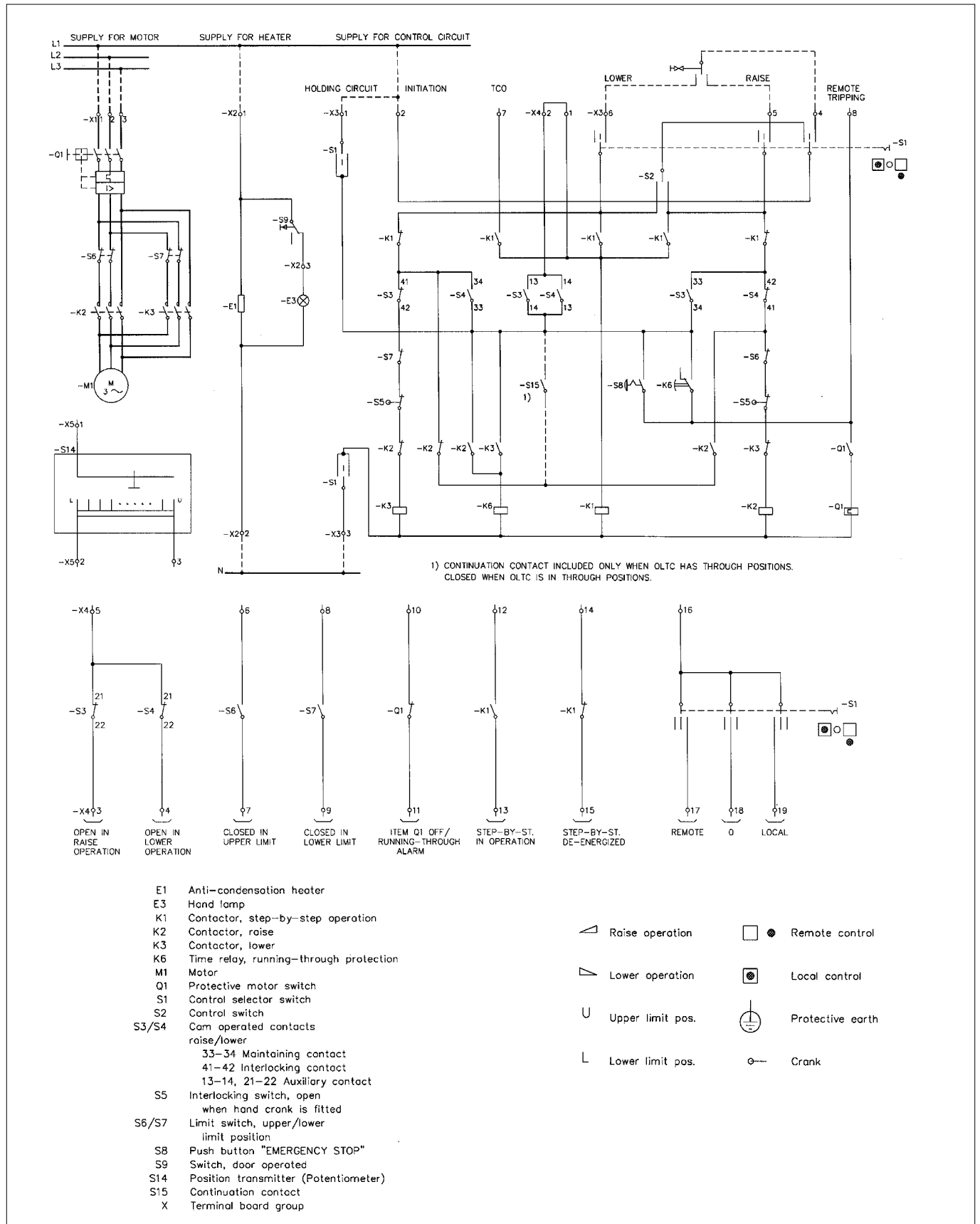

Fig. 9.

Contact Timing Diagram

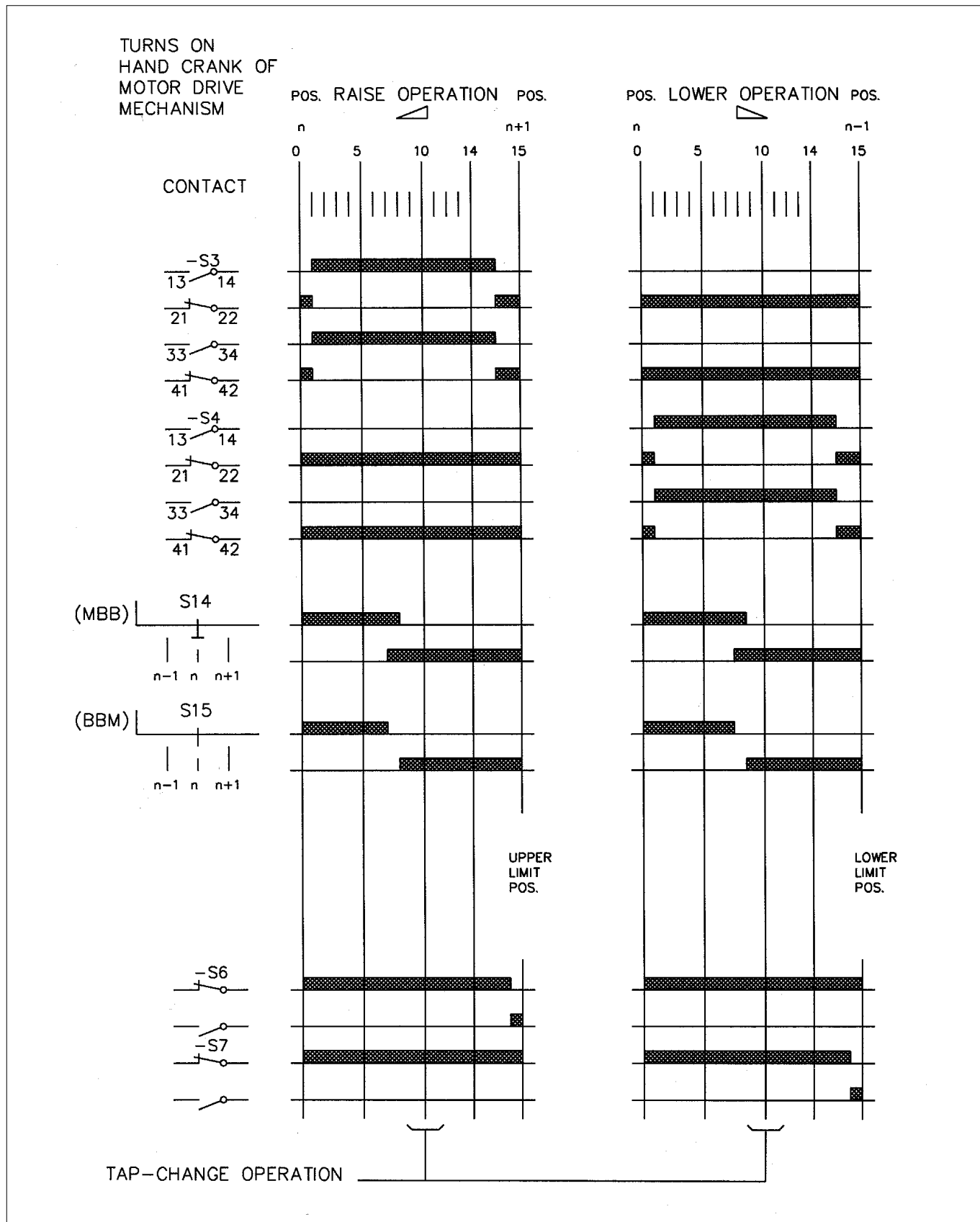

Fig. 10.

S3 Maintaining, interlocking and auxiliary contact, Raise
 S4 Maintaining, interlocking and auxiliary contact, Lower
 S15 Continuation contact

S14 Position transmitter, potentiometer
 S6 Limit switch, Upper tap position
 S7 Limit switch, Lower tap position

Standard Version

Control

- Control selector switch, Local-0-Remote.
- Control switch, Raise-0-Lower.
- Hand crank for manual operation.

Protection

- Protective switch for the motor with thermal overload release and magnetic overcurrent release.
- Limit switches – in both control and motor circuits.
- Mechanical end stops.
- Interlocking contact in the control circuit to prevent electrical operation during manual operation.
- Interlocking contacts in raise and lower control circuits to prevent operation in wrong direction of rotation (with wrong phase sequence).
- Motor contactors are electrically interlocked.
- Protection against running-through in case of a failure of the step-by step control circuit.
- Emergency stop push button.

Indication

- Mechanical position indicator
- Drag-hands for max. and min. position indication.
- Red flag for indication of Tap Changer in progress.
- Operation counter.
(The above four items are visible through the window in the cabinet door).
- Position transmitter, potentiometer, for remote position indication.

Wiring

The wiring is of grey polyvinylchloride-insulated, stranded wire. Type and data see *Technical data*. Every wire is marked with figures corresponding to terminal numbers. All external connections are made of thermosetting resin. Type and data see *Technical data*.

Short circuit protection (fuses) for control and heater supplies, if required, should be installed in the control cabinet or other separate compartment. No fuses are required for the motor, as the motor protective switch has magnetic overcurrent release.

Maintenance

All bearings in the Motor-Drive Mechanism type BUL have rubber seals and are permanently greased and some gears and moving details are made of selflubricating material. No greasing is necessary during the lifetime of the Motor-Drive Mechanism at normal working conditions.

The Motor-Drive Mechanism should be inspected once a year.

For the correct inspection and maintenance procedures, consult the appropriate *Maintenance Guide*.

Design Options

For already prepared design options, please see *Selection Guide* and *Ordering data* forms.

If other options than those listed in the *Selection Guide* and *Ordering data* forms are required, please consult ABB.

Multi-Position Switches

Maximum 5 contact rows can be accommodated, including one continuation contact when there are through positions.

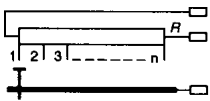
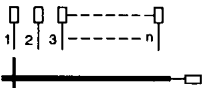
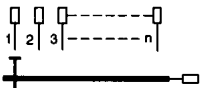
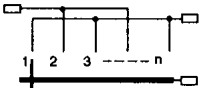
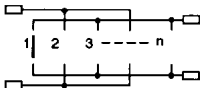
Position transmitter	Auxiliary contact Break before make	Auxiliary contact Make before break	Step switches for parallel control	
			Type 1	Type 2
				
Number of contact rows 1	1	1	1	2

Note: Master switch for parallel control is a break-before-make auxiliary contact.

Technical Data

Subject	Standard version	Alternative version	Special version at an additional price
Motor voltage, 3-phase	220-240/380-420 V, 50 Hz	208/360 V, 60 Hz 220-240/380-420 V, 60 Hz 250-280/440-480 V, 60 Hz	120 V, 1-phase, 60 Hz 240 V, 1-phase, 60 Hz Optional
Current	1.4/0.8 A		
Rated output	0.18 kW		
Speed	1370 r/min		
Voltage for control circuit	220 V, 50 Hz	240 V, 50 Hz, 220 V, 60 Hz 120 V, 208 V, 240 V, 60 Hz	110 V, 220 V D.C. Optional
Voltage for heater	220-240 V	110, 120-127 V	Optional
Multi position switches	0.15 A, 230 V A.C. 0.15 A, 220 V D.C. L/R = 40 ms		
Mechanical position indicator	lowest position marked 1	middle position marked N	Optional
Terminal blocks in BUL			
Number of terminals supplied	28-Phoenix UK 5N 41 A, 800 V A.C. acc. to IEC cross sectional area: 0.5 - 4 sqmm		
Number of terminals that can be accommodated (depending on selected options)			122 - Phoenix UK 5N 116 - Weidmüller SAK 4/35 PA 92 - Phoenix URTK/S Ben 92 - Phoenix URTK/S 68 - Phoenix OTTA 6
Cabling	Type H07V2-K, 1.5 sq mm, 750 V, 90 °C Type H05V2-K, 0.75 sq mm, 500 V, 90 °C		Optional
Test voltage on control circuits	2 kV (50 Hz, 1 min)		
Anti-condensation heater	50 W		
Additional heater			100 W controlled by thermostat or hygrostat
Approx. operating time	5 sec		
Starting impulse length	> 0.5 sec		
Number of revolutions per operation of			
the outgoing driving shaft	5		
the hand crank	15		
Max. torque on the outgoing shaft	30 Nm		
Max. number of positions	35		
Degree of protection of cabinet	IP 56 acc. to IEC 529	(Dust protected/Protected against powerful water jets)	

Dimensions

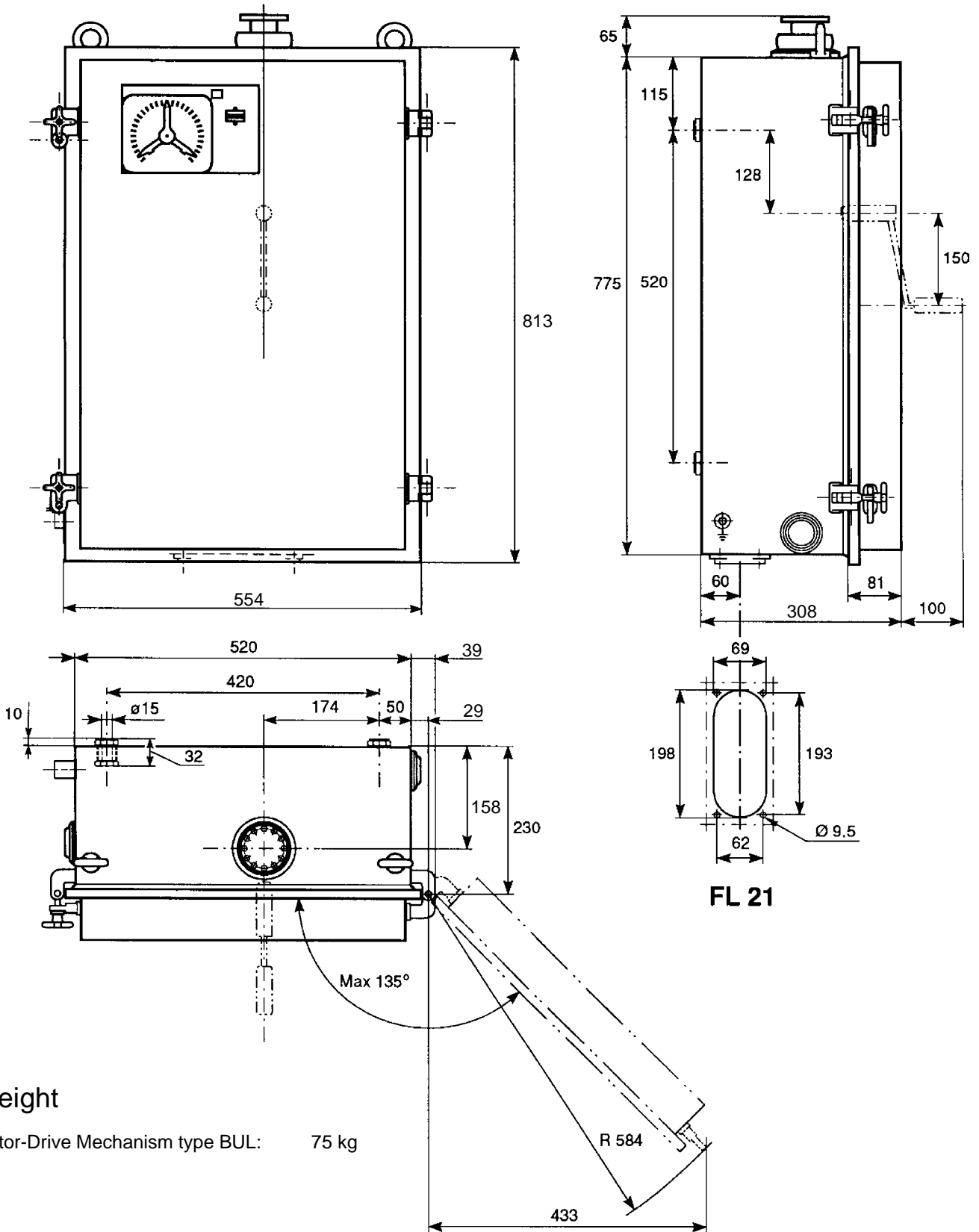

Weight

Motor-Drive Mechanism type BUL: 75 kg



**ABB Power Technology Products AB
Components**

Visiting address: Lyviksvägen 10

Postal address: SE-771 80 Ludvika, SWEDEN

Tel. +46 240 78 20 00

Fax +46 240 121 57

E-mail: sales@se.abb.com

www.abb.com

1ZSE 5483-105 en, Rev. 3, 2003-08-31