



200 Series Centrifugal Pumps



Centrifugal Pumps

For six decades, Waukesha Cherry-Burrell has been the leading producer of stainless steel rotary positive displacement pumps for the sanitary and industrial markets. Combining all of its manufacturing and application experience with advanced technology and new concepts, Waukesha takes particular pride in its 200 Series Centrifugal Pump Line, offering the pump user the benefits of Waukesha Cherry-Burrell's traditional quality, value and service with higher levels of performance.

Users of Waukesha Cherry-Burrell centrifugal pumps benefit from trained sales and application engineers that are always available for personal consultation to help solve installation or operational problems. This combines with a large number of fully-trained stocking distributors throughout the world, who can provide quality Waukesha Cherry-Burrell replacement parts and service.

Through the use of 316L stainless steel in all wetted parts, and extra heavy duty motor and solid drive linkage Waukesha's 200 Series centrifugal pumps are ideal product movers in a broad range of sanitary and industrial applications. In addition to being designed for cleaning in place, the pump is designed and manufactured to meet the requirements of U.S.D.A. 3A Standards.





- 3A Authorized
- USDA Approved
- Optional Industrial Models Available

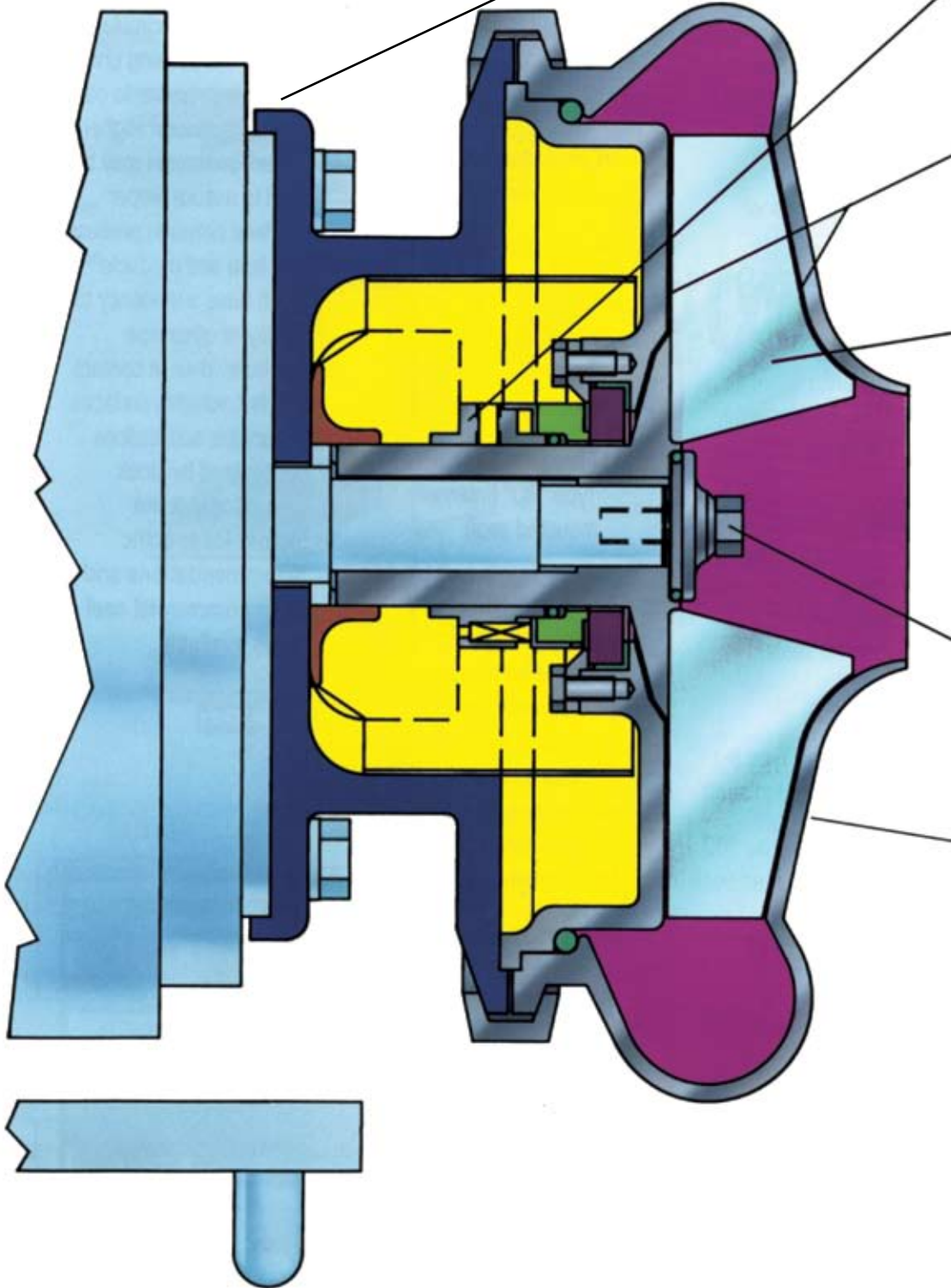

- Standard Stainless Steel Adapters
- Modular Seal Design
 - Wide range of seal options including commercially available seals
 - One size for entire model range
- Precise clearances for optimum performance
- 316L Impeller installs directly to motor shaft
 - Eliminates source of problems in other designs
 - Easy to position impeller
 - Fewer parts
 - Concentricity maintained
- Increased depth of impeller eye offers improved inlet characteristics
- 316L Casing
 - Rugged, strong construction with consistent dimensions
- JM Frame Motor
 - Designed for close coupled pumps; strong and reliable
 - Larger shaft; larger bearing director attaching impeller
 - Impeller close to bearing
- Tested Performance
 - Every pump passes strict testing requirements before being released for shipment.

Typical Products*

Efficiently Handled by 200 Series Pump

SANITARY

BAKERY -

Batters
Fats & Oils
Flavorings
Sweeteners
Yeast Slurry

BEVERAGE -

Alcohols & Wines
Beer, Wort, Yeast
Fruit Drinks
Soft Drinks

CONFECTIONERY -

Syrups

COSMETICS -

Dyes, Alcohols
Essential Oils

DAIRY -

Whey
Cream, Milk
Sweetened Condensed
RO/UF Systems

PHARMACEUTICAL -

Emulsions
Extracts
Slurries
Syrups
High Purity Water
WFI (Water for Injection)

INDUSTRIAL

Acetic Acid
Acetic Anhydride
Acetone
Aluminum Sulfate
Ammonium Chloride
Ammonium Hydroxide
Ammonium Nitrate
Aniline Dyes
Anhydrous Ammonia
Beet Juice
Benzene
Blood
Boric Acid
Brines
Butadiene
Butyl Alcohol
Calcium Carbonate
Carbolic Acid
Carbon Disulfide
Carbon Tetrachloride
Cellulose Acetate
Chloroform
Citric Acid
Cleansers
Detergents
Dyes
Ether
Ethyl Alcohol
Fatty Acids
Ferric Sulfate
Formaldehyde Freon
Fruit Acid
Furfural
Gelatin
Glycerin
Glycols-Ethylene
Hydrazine
Hydrogen Peroxide
Ink
Insecticides
Ketones
Lacquers

Lactic Acid
Lactose
Latex
Magnesium Sulfate
Methyl Alcohol
Methyl Ethyl Ketone
Naphtha
Oils, Mineral & Vegetable
Oxalic Acid
Paint
Palmitic Acid
Phosphoric Acid below 85%
Plasticizers
Polyvinyl Acetate
Polyvinyl Chloride
Potassium Chloride
Propyl Alcohol
RO/UF Systems
Rosin
Soap Liquors & Solutions
Sodium Acetate
Sodium Bisulfide
Sodium Carbonate
Sodium Cyanide
Sodium Hydroxide
Sodium Nitrate
Sodium Peroxide
Sodium Phosphate (neutral)
Sodium Silicate
Starch Slurry
Styrene
Tallow
Tannic Acid
Toluene
Trichloroethylene
Turpentine
Waxes & Emulsions
Xylene
Zinc Sulfate

*Consult Factory for Specific Recommendations.

Where Waukesha Departs From the “Norm” in Centrifugal Pump Design:

- Exclusive direct assembly of impeller-to-motor shaft for maximum rigidity and longer seal life.
- Clearance-ideal for all applications and a wide range of temperatures (to 450° F.).
- Designed for cleaning in place (CIP).
- Stronger JM-type motor has larger bearings and stronger shaft.
- Base mounting options available for all sizes.
- Extra deep impeller “eye” offers improved inlet characteristics.

Waukesha Centrifugal Pumps are More Durable, Efficient, and Economical than Other Centrifugals

Our design eliminates problems with vibration, short bearing life, low NPSH requirements, high seal maintenance costs and poor tolerance to adverse operating conditions. The Waukesha line offers an advanced generation of pumps. In all aspects of design, construction and performance, Waukesha Centrifugal pumps are a generation ahead of the industry.

Construction

Features:

Pump Motor Bracket - Stainless Steel.

Motor Types - NEMA JM Frame (standard): TEFC and Washdown enclosures available from stock. Energy-efficient, Chem-duty, Explosion Proof and stainless steel also available, as well as single phase or three phase, 60 or 50 Hertz.

Casing - Investment Cast 316L, satin exterior with sanitary finish in product zone.

Port Connections -S-Clamp; Bevel Seat; Flanged; NPT Threaded; I-Line; DIN; Butt Weld.

Mounting - Heavy duty flange with clamp.

Backplate - Machined from solid bar 316L stainless steel.

Impeller - Machined from solid bar 316L stainless steel with five compound curved vanes with integral motor shaft sleeve (2045 has four vanes.) Directly bolted to motor shaft with impeller retaining nut.

Specifications

Model	Inlet Size in (mm)		Outlet Size in (mm)		Maximum Impeller Size In (mm)		Maximum Capacity GPM (m3/hr)				Maximum Head Feet (Meters)			
							1750 RPM		3500 RPM		1750 RPM		3500 RPM	
2045	1.50	(38)	1.50	(38)	4.50	(114)	97	(22)	190	(43)	22	(7)	88	(27)
	2.0	(31)	1.50	(38)	4.50	(114)	97	(22)	190	(43)	22	(7)	88	(27)
2065LV	1.50	(38)	1.50	(38)	6.50	(165)	100	(23)	200	(45)	44	(13)	180	(55)
	2.00	(51)	1.50	(38)	6.50	(165)	100	(23)	200	(45)	44	(13)	180	(55)
	2.50	(65)	1.50	(38)	6.50	(165)	100	(23)	200	(45)	44	(13)	180	(55)
2065	2.50	(65)	2.00	(51)	6.50	(165)	245	(56)	400	(91)	47	(14)	190	(58)
2065HV	3.00	(76)	2.00	(51)	6.50	(165)	370	(84)	500	(114)	50	(15)	200	(61)
2075	3.00	(76)	1.50	(38)	8.6875	(218)	125	(28)	300	(68)	80	(24)	320	(98)
2085LV	2.00	(51)	1.50	(38)	8.50	(216)	70	(16)	145	(33)	81	(24)	330	(100)
2085	3.00	(76)	2.50	(64)	8.6875	(218)	480	(109)	840	(191)	85	(26)	342	(104)
	4.00	(102)	2.50	(64)	8.6875	(218)	480	(109)	840	(191)	85	(26)	342	(104)
2105	4.00	(102)	4.00	(102)	10.50	(267)	1400	(318)	N/A	N/A	133	(41)	N/A	N/A
2105	6.00	(152)	4.00	(102)	10.50	(267)	1400	(318)	N/A	N/A	133	(41)	N/A	N/A

Seals - One Seal Size Fits All Waukesha 200 Series Model

Waukesha's one-piece impeller/shaft sleeve design not only extends the life of seals, but it reduces the number of shaft seal sizes to one, resulting in a minimum spare parts inventory requirement.

Waukesha stationary seals are designed to last longer with a siliconized carbon (standard) lapped seat that is replaceable and reversible. This provides an excellent mating surface for the variety of rotary seals including food grade hard carbon, siliconized carbon, silicon carbide and tungsten carbide. No matter how demanding your application, there's a Waukesha seal that's tough enough to handle it.

Waukesha's pump offering includes eight sizes of pumps from 4-1/2" to 10-1/2" impeller diameter. All use the same size seal. These pumps have:

Seal combination options of:

- Single external mechanical seal
- Single mechanical with a water cascade
- Double mechanical seal

Optional Elastomer Choices:

- Fluoroelastomer O-Ring Standard
- EPDM
- Silicone
- Perfluoroelastomer (FFKM)

Waukesha pumps are also set up to accept, as standard, a large number of commercially available mechanical seals.

For Example:

- John Crane Type 8-1 (inside mounted seal)
- John Crane Type 8B2 (outside mounted seal)
- John Crane Type 8-1 Double Seal
- John Crane Type 9 (inside mounted seal)
- John Crane Type 9 Double Seal
- John Crane Type 21 (inside mounted seal)
- John Crane Type 21 (Double seal)
- Chesterton 440 (outside mounted seal)
- Chesterton 880 (inside mounted seal)
- Flowserve/Durametallic Type "CRO" Double Seal
- Flowserve/Durametallic Type "RA" (externally mounted seal)
- Flowserve/Durametallic Type "RO" (internally mounted seal)

An optional water cascade attachment is available for handling products that tend to crystallize. It also protects the seal against overheating due to high vacuum conditions or high product temperatures.

For particularly adverse applications, Waukesha pumps are also available with an external balanced seal with replaceable silicon carbide mating surface. The water-cooled rotary double seal (Type 4) features two seals fully enclosed with a stainless steel seal housing. Water or other suitable coolant circulates through the housing under moderate pressure to cool the seal surfaces.

Higher coolant pressures may be used to assure proper interface between product seal face and products which have a tendency to solidify or otherwise denature when in contact with hot, rotating surfaces. For unique applications not covered by stock seals: **Consult the factory for specific recommendations and other commercial seal types available.**

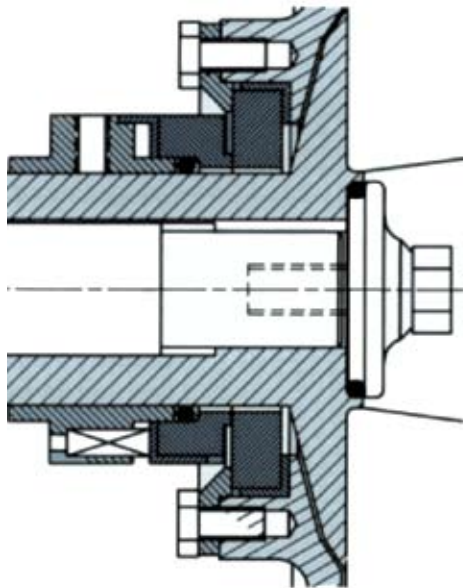

Type 1 External Balanced Seal with Replaceable Mating Surface

Water
Cascade
Option

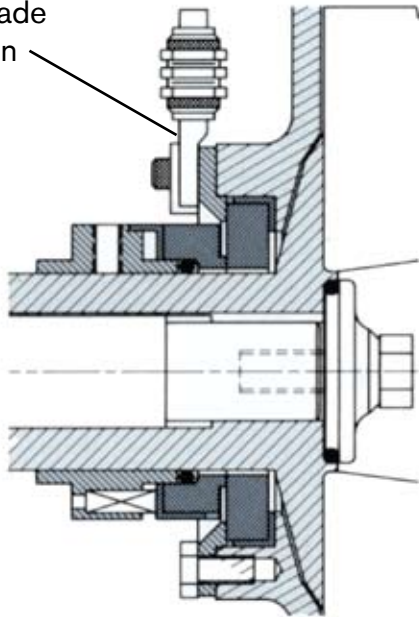

Type 1 With Water Cascade Option

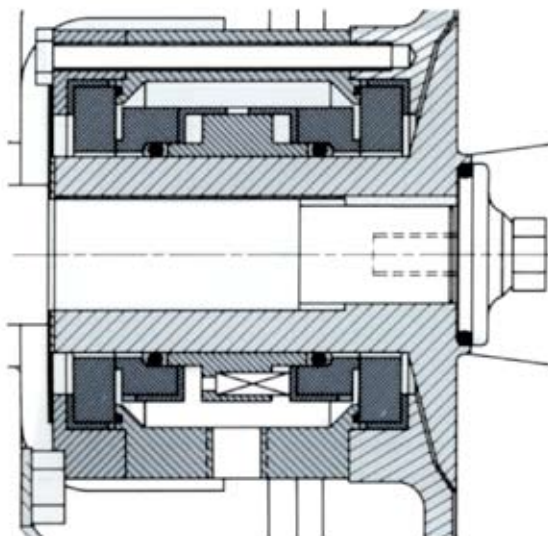
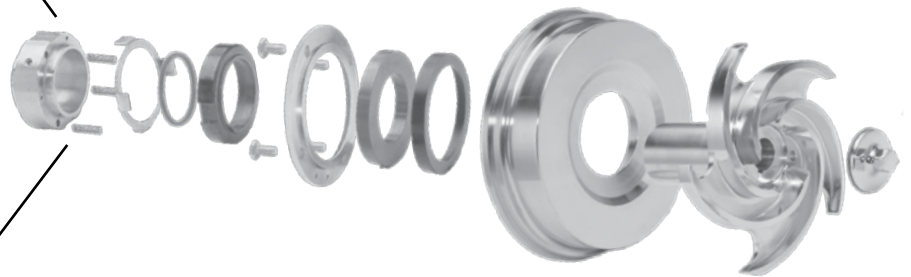

Type 4 Double Mechanical

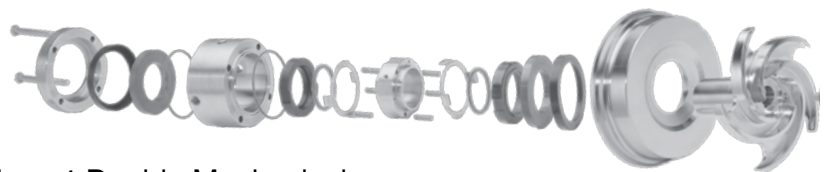

The Waukesha Volute Casing (High Capacity Models are More Versatile)

The optimized Waukesha design performs more efficiently over a wide range of operating conditions. The efficient casing and port design maximize performance under low NPSH conditions.

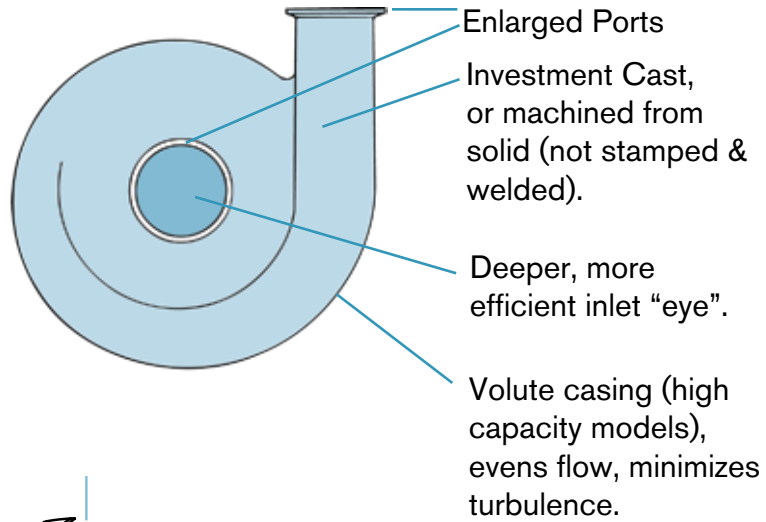

Waukesha's Exclusive Impeller Design

The Waukesha impeller/shaft sleeve is a single, piece mounted rigidly on the motor shaft. Unlike C-flange mounted pumps, it stays aligned and performs with less vibration under the most rigorous operating conditions and maximizes seal life.

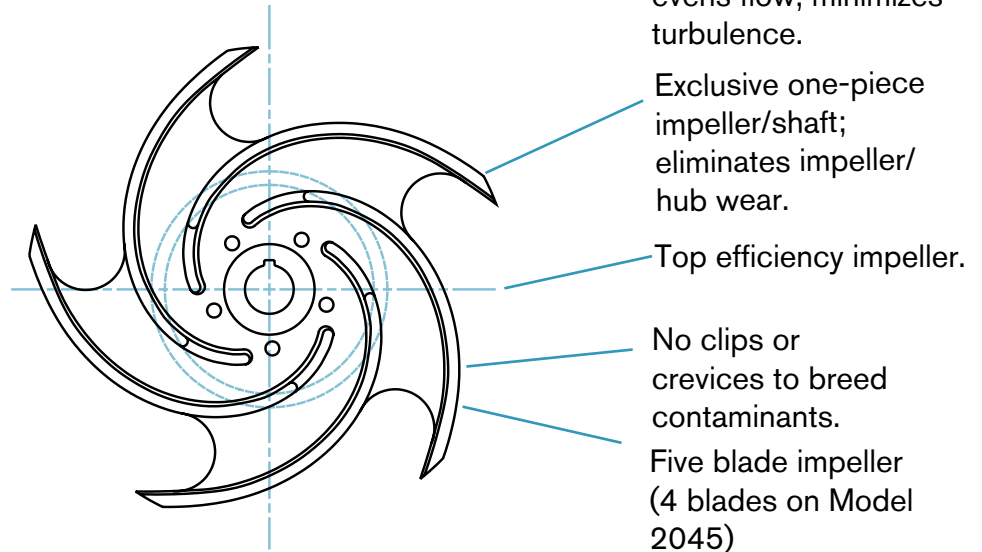

Waukesha Offers Exclusive NEMA JM Frame Motors for both Sanitary and Industrial Applications

JM Frame Motors are specifically designed for centrifugal close coupled pumps and conform to NEMA, Hydraulic Institute and ANSI Standards

Heavier front bearing extends life.

Extra large motor shaft increases rigidity, reduces vibration.

Direct connecting impeller; no stub shaft required.

Enclosure Options:

- TEFC
- EXPLOSION PROOF
- CHEM-DUTY
- WASHDOWN
- ENERGY-EFFICIENT
- STAINLESS STEEL

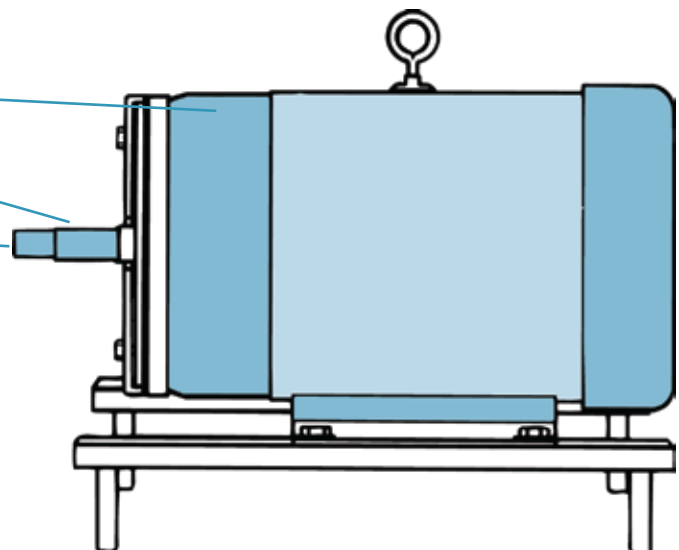

Close-Coupled Model Dimensions

Unit Width Height

FRAME	A in (mm)	B in (mm)	D in (mm)	F in (mm)	G in (mm)
145JM	8.56 (218)	7.87 (200)	4.5 (114)	.50 (13)	5.25 (133)
182JM	9.81 (249)	9.44 (240)	5.50 (140)	.75 (19)	5.87 (149)
184JM	9.81 (249)	9.44 (240)	5.50 (140)	.75 (19)	5.87 (149)
213JM	12.18 (309)	11.06 (281)	6.25 (159)	.75 (19)	7.38 (187)
215JM	12.18 (309)	11.06 (281)	6.25 (159)	.75 (19)	7.38 (187)
254JM	14.68 (373)	13.00 (330)	7.25 (184)	1.00 (25.4)	8.94 (227)
256JM	14.68 (373)	13.00 (330)	7.25 (184)	1.00 (25.4)	8.94 (227)
284JM	18.87 (225)	14.63 (372)	8.00 (203)	1.50 (38)	12.25 (311)
286JM	18.87 (225)	14.63 (372)	8.00 (203)	1.50 (38)	12.25 (311)
324JM	20.75 (527)	16.56 (421)	9 (229)	1.50 (38)	13.18 (335)
326JM	20.75 (527)	16.56 (421)	9 (229)	1.50 (38)	13.18 (335)

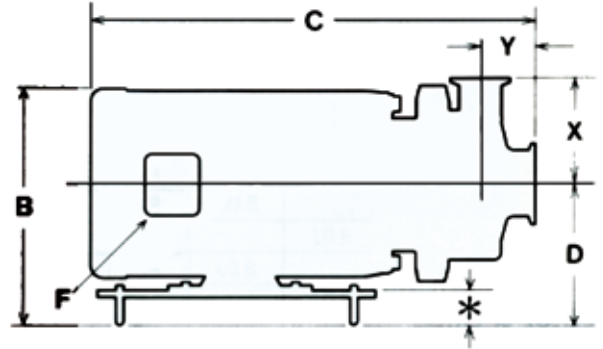

Fluid Head

MODEL	INLET in (mm)	OUTLET in (mm)	X in (mm)	Y in (mm)	Z in (mm)
2045	1.5 (40)	1.5 (40)	3.88 (98)	1.81 (46)	2.25 (57)
2045	2.0 (50)	1.5 (40)	3.88 (98)	1.81 (46)	2.25 (57)
2065LV	1.5 (40)	1.5 (40)	4.75 (120)	1.94 (49)	3.19 (81)
2065LV	2.0 (50)	1.5 (40)	4.75 (120)	1.94 (49)	3.19 (81)
2065LV	2.5 (65)	1.5 (40)	4.75 (120)	1.94 (49)	3.19 (81)
2065	2.5 (65)	2.0 (50)	4.44 (113)	1.94 (49)	3.94 (100)
2065HV	3.0 (75)	2.0 (50)	4.44 (113)	1.94 (49)	3.94 (100)
2075	3.0 (75)	1.5 (40)	6.69 (170)	1.75 (44)	4.50 (114)
2085LV	2.0 (50)	1.5 (40)	6.69 (170)	1.75 (44)	4.50 (114)
2085	3.0 (75)	2.5 (65)	5.63 (143)	2.53 (64)	5.06 (129)
2085	4.0 (100)	2.5 (65)	5.63 (143)	2.03 (52)	5.06 (129)
2105	4.0 (100)	4.0 (100)	6.94 (176)	2.86 (73)	6.75 (171)
2105	6.0 (150)	4.0 (100)	6.94 (176)	2.90 (74)	6.75 (171)

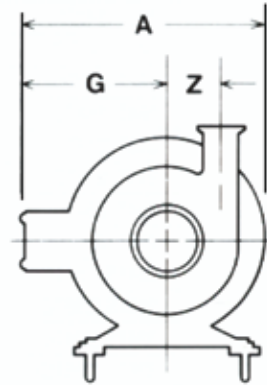

FRAME	MODEL/SIZE (INLET X OUTLET)									
	2045-ALL	2065LV-ALL	2065-2 ¹ /2x2	2065HV-3x2	2075	2085LV-2x1 ¹ /2	2085-3x2 ¹ /2	2085-4x2 ¹ /2	2105-4x4	2105-6x4
	C in (mm)	C in (mm)	C in (mm)	C in (mm)	C in (mm)	C in (mm)	C in (mm)	C in (mm)	C in (mm)	C in (mm)
145JM	18.94 (481)	16.35 (415)	16.94 (430)	17.04 (433)	16.16 (410)	16.16 (410)	17.50 (445)	17.05 (433)		
182JM	21.81 (554)	19.66 (500)	20.25 (514)	20.35 (517)	18.09 (459)	18.09 (459)	19.43 (494)	18.96 (482)		
184JM	21.81 (554)	19.66 (500)	20.25 (514)	20.35 (517)	18.09 (459)	18.09 (459)	19.43 (494)	18.96 (482)	25.13 (638)	25.16 (639)
213JM		21.91 (557)	22.50 (572)	22.60 (574)	21.72 (552)	21.72 (552)	23.05 (585)	22.55 (573)	23.88 (607)	23.91 (607)
215JM		21.91 (557)	22.50 (572)	22.60 (574)	21.72 (552)	21.72 (552)	23.05 (585)	22.55 (573)	26.56 (675)	26.59 (675)
254JM		25.47 (647)	26.06 (662)	26.17 (665)	25.53 (648)	25.53 (648)	26.87 (682)	26.43 (671)	27.63 (702)	27.66 (703)
256JM			27.81 (706)	27.92 (709)	25.53 (648)	25.53 (648)	26.87 (682)	26.43 (671)	29.38 (746)	29.41 (747)
284JM				28.44 (722)	27.66 (703)	27.66 (703)	29.00 (737)	28.50 (724)	29.94 (760)	29.97 (761)
286JM				29.94 (760)	29.16 (741)	29.16 (741)	30.50 (775)	30.00 (762)	31.44 (799)	31.47 (799)
324JM					29.97 (761)	29.97 (761)	31.31 (795)	30.81 (782)	31.63 (803)	31.66 (804)
326JM					31.47 (799)	31.47 (799)	32.81 (833)	32.31 (821)	32.87 (835)	32.91 (836)

Notes:

(1) *Frames 254-326: 2.50/64 adjustment \pm 1.00/25.4

Frames 143-215: 2.00/51 adjustment \pm 1.00/25.4

(2) Dimensions X, & C apply to pumps with clamp connection.

Pedestal Mounted Model Dimensions

Pump & Pedestal						B	
MODEL	INLET in (mm)	OUTLET in (mm)	X in (mm)	Y in (mm)	Z in (mm)	SM. BORE in (mm)	LG. BORE in (mm)
P2045	1.5 (40)	1.5 (40)	3.88 (98)	1.81 (46)	2.25 (57)	14.10 (358)	-
P2045	2.0 (50)	1.5 (40)	3.88 (98)	1.81 (46)	2.25 (57)	14.10 (358)	-
P2065LV	1.5 (40)	1.5 (40)	4.75 (120)	1.94 (49)	3.19 (81)	13.83 (351)	-
P2065LV	2.0 (50)	1.5 (40)	4.75 (120)	1.94 (49)	3.19 (81)	13.83 (351)	-
P2065LV	2.5 (65)	1.5 (40)	4.75 (120)	1.94 (49)	3.19 (81)	13.83 (351)	-
P2065	2.5 (65)	2.0 (50)	4.44 (113)	1.94 (49)	3.94 (100)	14.42 (366)	-
P2065HV	3.0 (75)	2.0 (50)	4.44 (113)	1.94 (49)	3.94 (100)	14.53 (369)	21.30 (541)
P2075	3.0 (75)	1.5 (40)	6.69 (176)	1.75 (44)	4.50 (114)	17.19 (436)	20.42 (581)
P2085LV	2.0 (50)	1.5 (40)	6.69 (170)	1.75 (44)	4.50 (114)	13.80 (351)	20.42 (519)
P2085	3.0 (75)	2.5 (65)	5.63 (143)	2.53 (64)	5.06 (129)	15.01 (381)	21.64 (550)
P2085	4.0 (100)	2.5 (65)	5.63 (143)	2.03 (52)	5.06 (129)	14.51 (368)	21.14 (537)
P2092	3.0 (75)	2.0 (50)	6.64 (169)	2.47 (63)	4.62 (117)	14.46 (367)	21.09 (536)
P2105	4.0 (100)	4.0 (100)	6.94 (176)	2.86 (73)	6.75 (171)	-	22.57 (573)
P2105	6.0 (150)	4.0 (100)	6.94 (176)	2.90 (74)	6.75 (171)	-	22.60 (574)

Motor & Base

MOTOR FRAME	A in (mm)	SC		H		SH	
		SM. BORE in (mm)	LG. BORE in (mm)	SM. BORE in (mm)	LG. BORE in (mm)	SM. BORE in (mm)	LG. BORE in (mm)
56 (56C)	11.50 (292)	8.70 (221)	-	8.85 (225)	-	9.60 (244)	-
142T (142TC)	11.50 (292)	8.70 (221)	-	8.85 (225)	-	9.60 (244)	-
143T (143TC)	12.50 (318)	8.70 (221)	-	8.85 (225)	-	9.60 (244)	-
145T (145TC)	12.50 (318)	8.70 (221)	-	8.85 (225)	-	9.60 (244)	-
182T (182TC)	16.18 (411)	8.70 (221)	-	8.85 (225)	-	9.35 (238)	-
184T (184TC)	16.25 (413)	8.66 (220)	-	8.85 (225)	-	9.35 (238)	-
213T (213TC)	19.81 (503)	8.70 (221)	11.96 (304)	9.71 (247)	12.90 (328)	9.35 (238)	13.70 (348)
215T (215TC)	19.81 (503)	8.70 (221)	11.96 (304)	9.71 (247)	12.90 (328)	9.35 (238)	13.70 (348)
254T (254TC)	21.75 (552)	8.70 (221)	7.51 (191)	9.71 (247)	12.90 (328)	10.15 (258)	13.70 (348)
256T (256TC)	23.50 (597)	8.70 (221)	7.51 (191)	9.71 (247)	12.90 (328)	10.15 (258)	13.70 (348)
284TS (284TC)	25.00 (635)	-	9.96 (253)	-	13.70 (348)	-	13.70 (348)
286TS (286TC)	26.75 (680)	-	9.96 (253)	-	13.70 (348)	-	13.70 (348)
324TS (324TC)	28.88 (733)	-	7.25 (184)	-	13.70 (348)	-	14.45 (367)
326TS (326TC)	30.38 (772)	-	7.25 (184)	-	13.70 (348)	-	14.45 (367)
364TS (364TC)	31.68 (805)	-	5.34 (136)	-	13.70 (348)	-	14.45 (367)
365TS (365TC)	32.68 (830)	-	5.34 (136)	-	13.70 (348)	-	14.45 (367)

MOTOR FRAME	D		SD		W		SW	
	SM. BORE in (mm)	LG. BORE in (mm)	SM. BORE in (mm)	LG. BORE in (mm)	SM. BORE in (mm)	LG. BORE in (mm)	SM. BORE in (mm)	LG. BORE in (mm)
56 (56C)	24.00 (610)	-	20.00 (508)	-	10.00 (254)	-	10.00 (254)	-
142T (142TC)	24.00 (610)	-	20.00 (508)	-	10.00 (254)	-	10.00 (254)	-
143T (143TC)	24.00 (610)	-	20.00 (508)	-	10.00 (254)	-	10.00 (254)	-
145T (145TC)	24.00 (610)	-	20.00 (508)	-	10.00 (254)	-	10.00 (254)	-
182T (182TC)	26.25 (667)	-	20.00 (508)	-	10.00 (254)	-	10.00 (254)	-
184T (184TC)	26.25 (667)	-	20.00 (508)	-	10.00 (254)	-	10.00 (254)	-
213T (213TC)	28.75 (730)	32.00 (813)	26.00 (660)	32.00 (813)	15.00 (381)	15.00 (381)	10.00 (254)	15.00 (381)
215T (215TC)	28.75 (730)	32.00 (813)	26.00 (660)	32.00 (813)	15.00 (381)	15.00 (381)	10.00 (254)	15.00 (381)
254T (254TC)	32.00 (813)	38.00 (965)	32.00 (813)	32.00 (813)	15.00 (381)	15.00 (381)	15.00 (381)	15.00 (381)
256T (256TC)	32.00 (813)	38.00 (965)	32.00 (813)	32.00 (813)	15.00 (381)	15.00 (381)	15.00 (381)	15.00 (381)
284TS (284TC)	-	38.00 (965)	-	32.00 (813)	-	15.00 (381)	-	15.00
286TS (286TC)	-	38.00 (965)	-	32.00 (813)	-	15.00 (381)	-	15.00
324TS (324TC)	-	50.00 (1270)	-	32.00 (813)	-	18.00 (457)	-	18.00 (457)
326TS (326TC)	-	50.00 (1270)	-	32.00 (813)	-	18.00 (457)	-	18.00 (457)
364TS (364TC)	-	50.00 (1270)	-	32.00 (813)	-	18.00 (457)	-	18.00 (457)
365TS (365TC)	-	50.00 (1270)	-	32.00 (813)	-	18.00 (457)	-	18.00 (457)

Motor & Pedestal

MOTOR HP & RPM	PUMP MODEL							
	P2045	P2065LV	P2065	P2065HV	P2085LV	P2085	P2092	P2105
Up to 5HP 1750 RPM	SM.B.	SM.B.	SM.B.	SM.B.	SM.B.	SM.B.	SM.B.	
Up to 5HP 3500 RPM	SM.B.	SM.B.	SM.B.					
7 ¹ / ₄ HP 1750 RPM						SM.B.	SM.B.	LG.B.
7 ¹ / ₄ HP 3500 RPM		SM.B.	SM.B.	SM.B.	SM.B.	SM.B.	SM.B.	
10HP 1750 RPM						SM.B.	SM.B.	LG.B.
10HP 3500 RPM		SM.B.	SM.B.	SM.B.	SM.B.	SM.B.	SM.B.	
15HP 1750 RPM								LG.B.
15HP 3500 RPM			SM.B.	SM.B.	SM.B.	SM.B.	SM.B.	
20HP 1750 RPM								LG.B.
20HP 3500 RPM			SM.B.	SM.B.	SM.B.	SM.B.	SM.B.	
25HP 1750 RPM								LG.B.
25HP 3500 RPM				LG.B.		LG.B.	LG.B.	
30HP 1750 RPM								LG.B.
30HP 3500 RPM				LG.B.		LG.B.	LG.B.	
40HP 1750 RPM								LG.B.
40HP 3500 RPM						LG.B.	LG.B.	
50HP 1750 RPM								LG.B.
50HP 3500 RPM						LG.B.	LG.B.	
60HP 3500 RPM						LG.B.	LG.B.	
75HP 3500 RPM						LG.B.	LG.B.	

Note: Sm.B. = Small Bore
Lg.B. = Large Bore

Style B

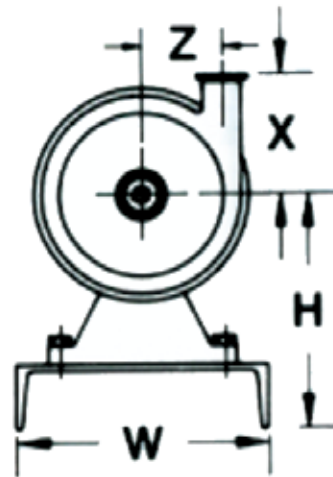
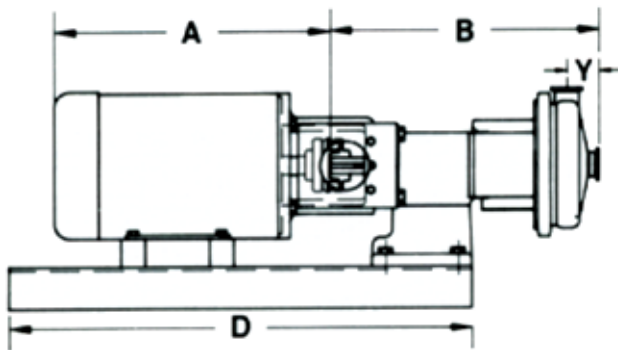

Style C (Standard)

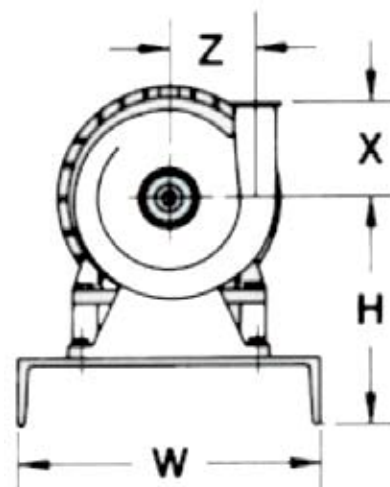
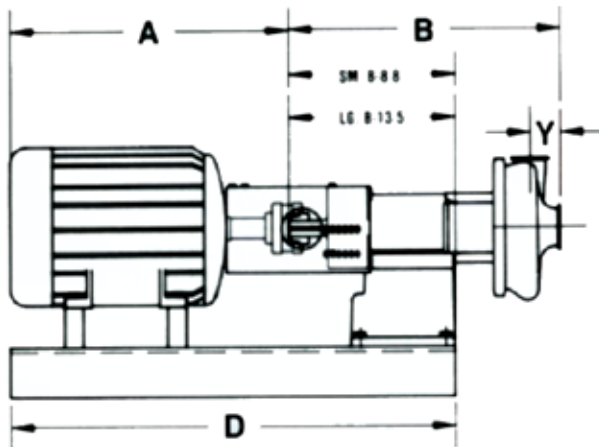

Note: Dimensions X, Y & B apply to pumps with clamp connection.

Capacity Curves

Based on water at 70°F. (22°C.)

Maximum Inlet Size ● = Best Efficiency Point

60 Hz

50 Hz

CAPACITY CURVES 3500 RPM

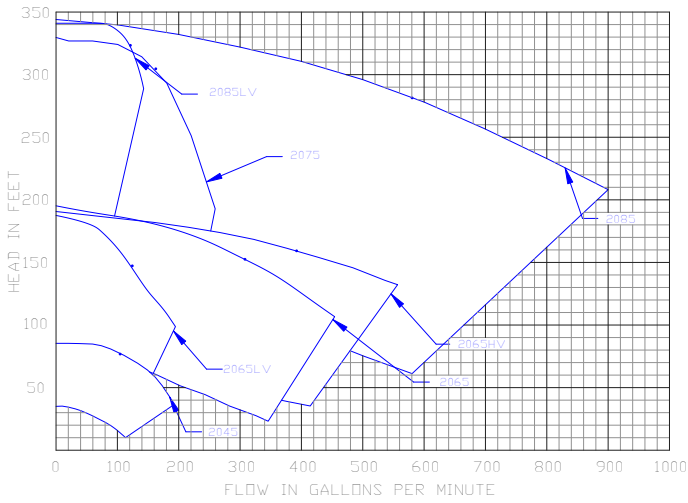

CAPACITY CURVES 2900 RPM

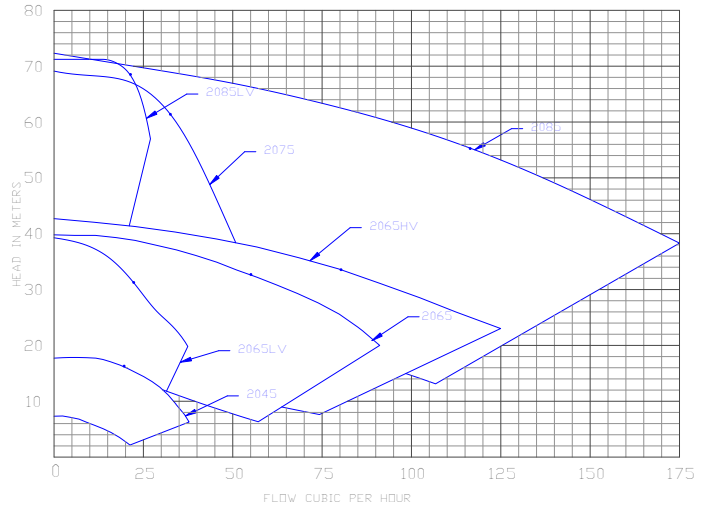

CAPACITY CURVES 1750 RPM

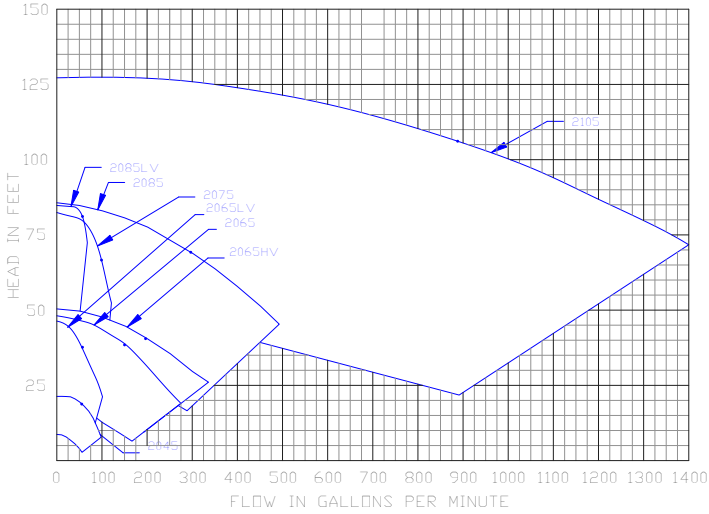

CAPACITY CURVES 1450 RPM

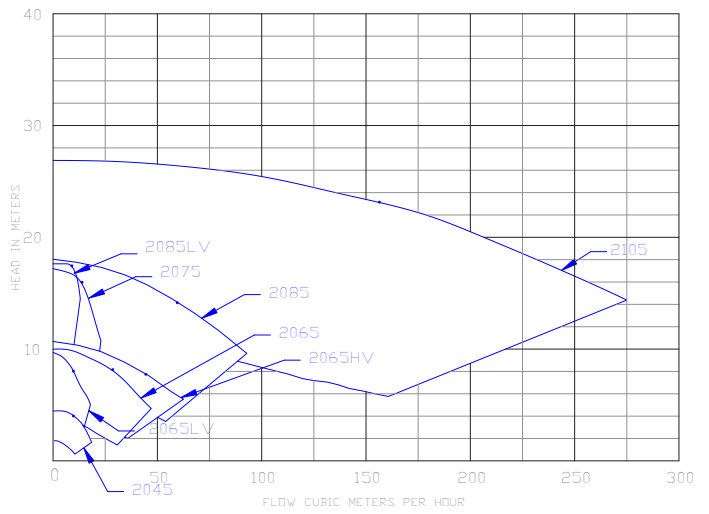



Waukesha Cherry-Burrell offers three single stage and one multistage high-pressure 200 Series centrifugal pump models. Designed for use in membrane filtration systems (reverse osmosis and ultra filtration), they can accommodate high system pressure inlet conditions to 1000 PSI producing a smooth, pulse-free high discharge pressure for reduced membrane wear and increased product quality.

FEATURES:

- Sanitary design for food and dairy processing service.
- Strong cast iron bearing frames, that provide support for the pump independent of the motor.
- Coupling alignment is assured by motor flange adapter resulting in longer pump life by reducing coupling wear, bearing loads and improving shaft seal performance.
- Large bearings with non-wearing labyrinth seals for longer life; low maintenance.
- Balanced double mechanical shaft seals that are the same size as used on all 200 series pumps; reducing inventory costs.
- Mounted on heavy plate steel bases with adjustable sanitary legs.

High Pressure Centrifugal Pumps

Specifications:

Model 2085HPLV

Inlet Size: 2.0" Discharge: 1 11/42"
 Max Head: 330 Ft. THD*
 Max Flow: 140 GPM *
 Max discharge Pressure: 700 PSI

*at 3500 RPM

Model 2085HP

Inlet Size: 2 11/42" Discharge: 2"
 Max Head: 340 Ft. THD*
 Max Flow: 400 GPM *
 Max discharge Pressure: 700 PSI

*at 3500 RPM

Model MS 2085 Multistage

Inlet Size: 2 11/42" Discharge: 1 11/42"
 Max Head: 600 Ft. THD*
 Max Flow: 250 GPM *
 Max discharge Pressure: 1250 PSI

*at 3500 RPM

Casing: 316SS

Port Connections: Sanitary S-Line (Clamp)

Backplate: 316L Stainless Steel

Impeller with Integral Shaft: 316L Stainless

Steel Impeller Retainer: 316L Stainless Steel

Shaft Seal: Double Mechanical - Type 4

Rotary Seal Material: Silicon Carbide inboard / Carbon outboard

Stationary Seal Material: Silicon Carbide inboard/ Purebide (Siliconized graphite) outboard

Elastomers: Fluoroelastomers FDA approved

Finish: All product contact surfaces polished to 150 grit (32 Ra)

Base Mounting: Stainless Steel

S200 Series All Machined Centrifugal Pumps

Designed for use in the Bio-Pharmaceutical industry, these pumps are manufactured to ASME BPE specification criteria. All product contact components are machined from wrought <5% ferrite level, 316L SS, and feature a 20 Ra product contact surface finish. Material heat numbers are available on all product contact components.

Standard Features:

- High efficiency, low NPSHR design for a wide variety of applications
- One size mechanical seal for all 200 Series models; reducing parts inventory and cost (commercial seals available)
- Integral impeller/shaft design for fewer parts, greater concentricity and easy maintenance
- Close coupled pumps use NEMA JM Frame motors with larger diameter shafts and bearings (compared to C Frame motors)
- All WCB 200 Series impellers are made from wrought 316L SS
- 304 SS motor adapter
- Horizontal, vertical, and 45° angle discharge port orientation available

Optional:

- 15 Ra., electropolish, and passivation product contact surface finishes
- WFI seal arrangements
- Double mechanical seals
- Casing drain
- SS motors



Aseptic Centrifugal Models



For aseptic flow applications, centrifugal models are available that retain the benefits of the Waukesha Heavy-Duty Centrifugal but also include special design features that protect the product zone against contamination. Modifications assure that every potential entry point for contaminated air or liquid is bathed in sterile steam.

The JM motor, equipped with a stainless steel shaft, is standard. Aseptic models may be specified in either pedestal or close-coupled configuration.

NOTE: Dimensions of close coupled and pedestal models are the same as those on pages 9 through 11.

Also Available: Waukesha C-Series Sanitary Pumps:

304 stainless steel adapters — standard, eliminate the rust, corrosion and chipping paint of conventional carbon steel adapters.

Longer seal life — wave spring provides more uniform loading on seal face than single coil spring; hydraulic balancing reduces sealing surface pressures for less wear and less downtime.

Fast, easy takedown — no tools required; quick-opening, heavy-duty cast clamp secures casing; impeller pin retained by centrifugal force.

Tested performance — every pump passes strict testing before release for shipping.

CIP capability — grooves-in-impeller/shaft routes CIP chemical solutions to all critical areas for clean-in-place.

Casing matches job — choose from standard or enlarged inlet with port connection that meets your piping system.

Models C-114 through C-328

Waukesha Cherry-Burrell Warranty

Seller warrants its products to be free from defects in materials and workmanship for a period of one (1) year from the date of shipment. This warranty shall not apply to products which require repair or replacement due to normal wear and tear or to products which are subjected to accident, misuse or improper maintenance. This warranty extends only to the original Buyer. Products manufactured by others and furnished by Seller are exempted from this warranty and are limited to the original manufacturer's warranty.

Because of Waukesha's constant program of improvement, specifications are subject to change without notice.



SPX[®]

PROCESS EQUIPMENT

Your local contact:

Holland[®]
APPLIED TECHNOLOGIES
Indianapolis • Chicago • San Juan
www.hollandapt.com
800-800-8464



SPX Process Equipment
611 Sugar Creek Road
Delavan, WI 53115
Phone: (262)728-1900 or (800)252-5200 Fax: (262)728-4904 or (800)252-5012
E-mail: wcb@spx.com

For more information about our worldwide locations, approvals, certifications, and local representatives, please visit www.spxpe.com.

SPX Corporation reserves the right to incorporate our latest design and material changes without notice or obligation. Design features, materials of construction and dimensional data, as described in this bulletin, are provided for your information only and should not be relied upon unless confirmed in writing. Certified drawings are available upon request.