

## 2001 Chevrolet Corvette

2000-01 ENGINES 5.7L V8 - Corvette

### 2000-01 ENGINES

#### 5.7L V8 - Corvette

## ENGINE IDENTIFICATION

**NOTE:** For repair procedures not covered in this article, see **ENGINE OVERHAUL PROCEDURES** article in **GENERAL INFORMATION**.

### VEHICLE IDENTIFICATION NUMBER (VIN)

Engine can be identified by eighth character of VIN which is stamped onto a metal pad located near lower left corner of windshield. A "G" in eighth character of VIN indicates 5.7L V8 (LS1) or 5.7L V8 (LS6) HO (2001 only). A "Y" in tenth character of VIN indicates 2000 model year. A "1" in tenth character of VIN indicates 2001 model year. Engine can also be identified by a 3-character engine code (RPO code). This code may be stamped onto engine, at flange where engine and transmission meet.

## ADJUSTMENTS

### VALVE CLEARANCE ADJUSTMENT

**NOTE:** Engine is equipped with non-adjustable hydraulic valve lifters.

## TROUBLE SHOOTING

**NOTE:** For trouble shooting engine components, see appropriate table in **TROUBLE SHOOTING** article in **GENERAL INFORMATION**.

## REMOVAL & INSTALLATION

**WARNING:** To avoid injury from accidental air bag deployment, read and carefully follow all **SERVICE PRECAUTIONS** and **DISABLING & ACTIVATING AIR BAG SYSTEM** procedures in appropriate **AIR BAG RESTRAINT SYSTEMS** article in **ACCESSORIES & EQUIPMENT**.

**CAUTION:** When battery is disconnected, vehicle computer and memory systems may lose memory data. Driveability problems may exist until computer systems have completed a relearn cycle.

**See COMPUTER RELEARN PROCEDURES article in GENERAL INFORMATION before disconnecting battery.**

**NOTE:** For reassembly reference, label all electrical connectors, vacuum hoses and fuel lines before removal. Also place mating marks onto engine hood and other major assemblies before removal.

#### FUEL PRESSURE RELEASE

Disconnect negative battery cable. Loosen fuel tank filler cap. Remove fuel rail cover. Connect Fuel Pressure Gauge (J 34730-1A) onto fuel pressure connection (wrap shop towel around fitting to avoid spillage). Install bleed hose, and place end into a container. Turn gauge valve, and drain fuel into an appropriate container.

#### COOLING SYSTEM BLEEDING

**CAUTION:** When removing radiator surge tank fill cap on a hot engine, slowly rotate cap counterclockwise approximately 1/4 turn. Stop and allow hissing to stop. After all hissing stops, continue turning counterclockwise to remove cap.

1. Fill system through radiator surge tank opening up to base of fill neck. Start engine and idle for one minute. Install radiator surge tank cap. Cycle RPM from idle to 3000 in 30 second intervals until engine coolant reaches 210°F (99°C). Shut off engine.
2. Loosen radiator surge tank cap. After all hissing stops, remove cap. Start engine. Idle engine for one minute and fill surge tank to between FULL COLD and FULL HOT. Install radiator surge tank cap. Cycle RPM from idle to 3000 in 30 second intervals until engine coolant reaches 210°F (99°C). Shut off engine. Top off coolant as necessary.

#### ENGINE

##### Removal

**NOTE:** Removal steps are in specific order. Follow steps in order to avoid possible vehicle damage.

1. For 2000 models, disconnect negative battery cable. Raise and support vehicle. Drain coolant. Lower vehicle. Discharge A/C system using approved refrigerant recovery/recycling equipment. Plug openings. Disconnect IAT and MAF sensor connectors. Disconnect fuel regulator purge line from air intake duct. Remove air intake duct and air

## 2001 Chevrolet Corvette

2000-01 ENGINES 5.7L V8 - Corvette

cleaner assembly. Remove upper radiator support. Remove radiator. Remove Electronic Brake Control Module/Break Pressure Modulator Valve (EBTCM/BPMV) and bracket. Position brake pipes aside. Remove accessory drive belt. Remove fuel rail covers. Relieve fuel system pressure. See **FUEL PRESSURE RELEASE** .

**NOTE: Cap fittings and plug holes when separating fuel system components in order to prevent leakage and/or dirt and other contaminants from entering fuel system.**

2. For 2001 models, discharge A/C system using approved refrigerant recovery/recycling equipment. Remove radiator. Remove Brake Pressure Modulator Valve (BPMV). Position brake pipes aside. Remove accessory drive belt. Remove right fuel rail cover. Relieve fuel system pressure. See **FUEL PRESSURE RELEASE** . Disconnect EVAP purge hose at fuel line.

**NOTE: Cap fittings and plug holes when separating fuel system components in order to prevent leakage and/or dirt and other contaminants from entering fuel system.**

3. For all models, disconnect fuel lines at fuel rail. Disconnect radiator and heater hoses from water pump. Disconnect electrical connectors from fuel injectors, ignition coil main connectors, evaporative purge solenoid, electric throttle motor, Throttle Position (TP) sensor, Engine Coolant Temperature (ECT) sensor and A/C compressor.
4. Disconnect generator electrical connectors. Remove generator rear bracket bolts and bracket. Remove generator mounting bolts and generator. Disconnect brake booster vacuum hose at brake booster. Remove intermediate shaft-to-steering shaft bolt. Disconnect intermediate steering shaft from steering gear, and wire aside. Disconnect Air Injection Reactor (AIR) hose from left exhaust manifold.

**NOTE: DO NOT remove engine flywheel housing-to-driveline support assembly bolts at this time.**

5. Raise vehicle. Remove front wheels. Remove intermediate exhaust pipe. Remove close-out panel bolts and panel to access lower engine components. Remove starter electrical connectors. Remove all grounds from right side of engine block. Remove starter bolts and starter. Disconnect oil level sensor connector. Disconnect crank position sensor connector. Disconnect right front HO<sub>2</sub>S connector. Remove A/C compressor hose retaining bolt. Remove A/C compressor hose from compressor, and plug openings. Disconnect engine oil temperature sensor connector. Disconnect all grounds from left side of engine block.

## 2001 Chevrolet Corvette

2000-01 ENGINES 5.7L V8 - Corvette

Disconnect left front HO2S connector.

6. Remove front stabilizer bar bolts and straps. Disconnect front stabilizer bar from cradle. Disconnect electrical connectors and harness from electric cooling fans. Remove electric cooling fan bolts and cooling fans.
7. Using Spring Compressor (J 33432-A), compress front transverse spring. See **Fig. 1** . Remove tie rod end nuts. Remove tie rod ends from steering knuckles using Ball Joint Separator (J 42188). Disconnect all electrical connectors at cradle. Remove lower shock absorber mounting bolts. Separate lower ball joints using ball joint separator. Remove spring compressor from front transverse spring.

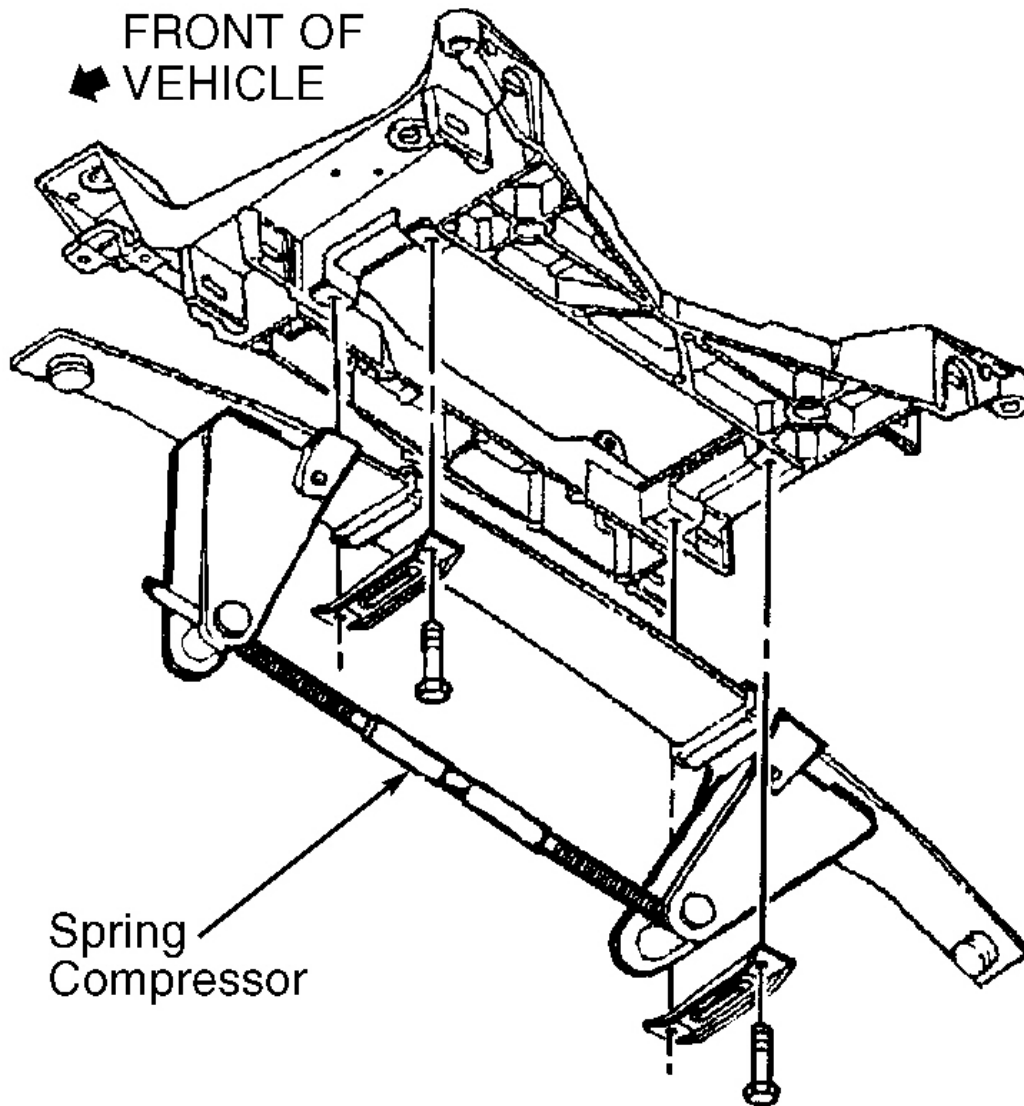

G98E12322

**Fig. 1: Compressing Front Transverse Spring.**  
Courtesy of GENERAL MOTORS CORP.

8. On A/T equipped vehicles, disconnect A/T cooler lines at engine flywheel housing junction and at radiator. Remove 2 plugs in driveline support assembly. See [Fig. 2](#) . Install a 55 mm or longer 10" X 1.5" bolt into each location. Tighten bearing support bolts to 26 ft. lbs. (35 N.m). Remove engine flywheel housing access plug. Rotate flywheel hub collar to access bolt, and loosen bolt. See [Fig. 3](#) . On M/T equipped models, Unclip clutch actuator hose

## 2001 Chevrolet Corvette

2000-01 ENGINES 5.7L V8 - Corvette

from engine flywheel housing clip. Using Hydraulic Clutch Line Separator (J 36221) depress release ring on actuator hose and simultaneously pull lightly on clutch master cylinder hose to disconnect. Wrap both ends of hose to protect them. Remove engine flywheel housing bolts from driveline support assembly.

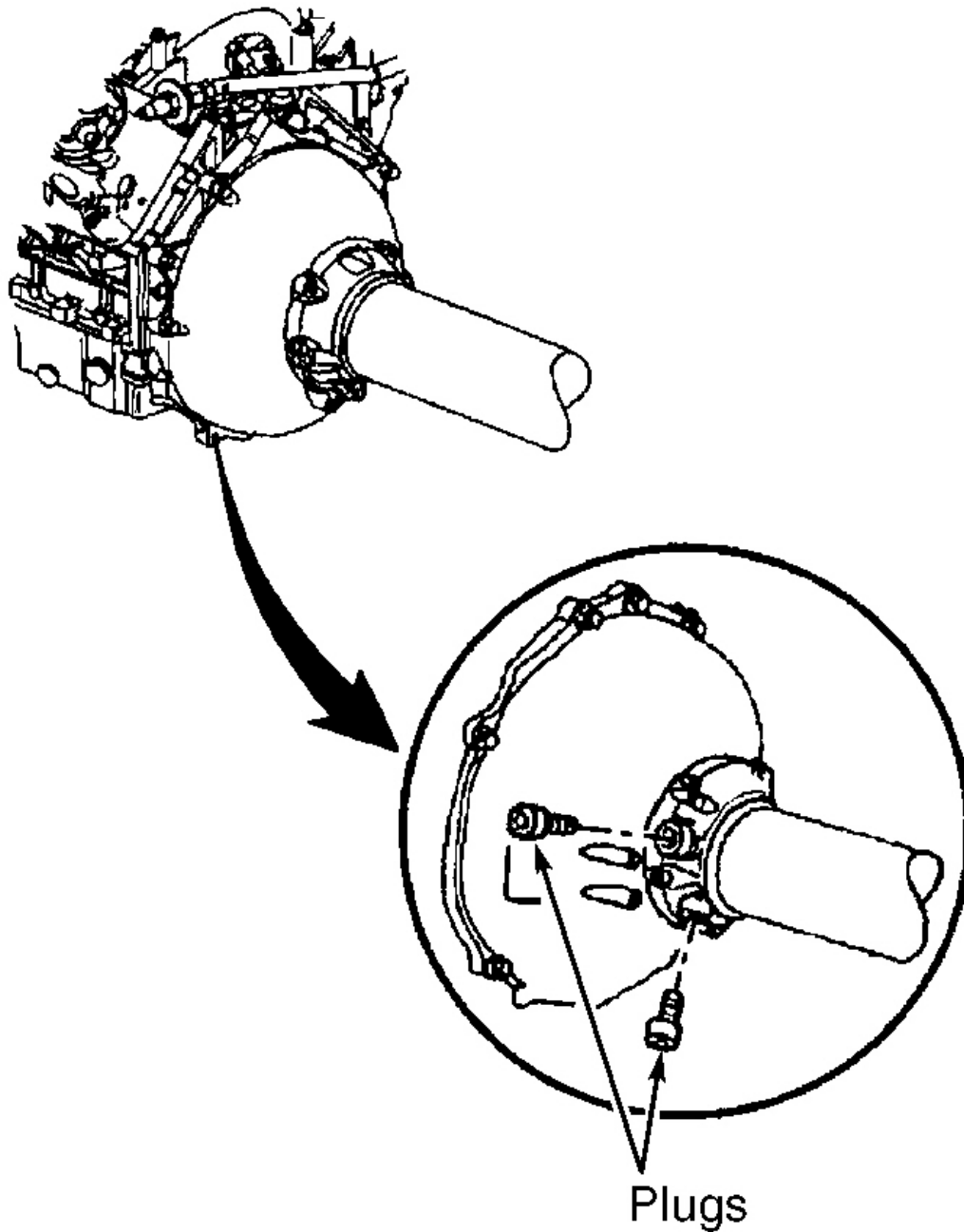

G98F12323

**Fig. 2: Identifying 2 Plugs In Driveline Support Assembly.**  
Courtesy of GENERAL MOTORS CORP.

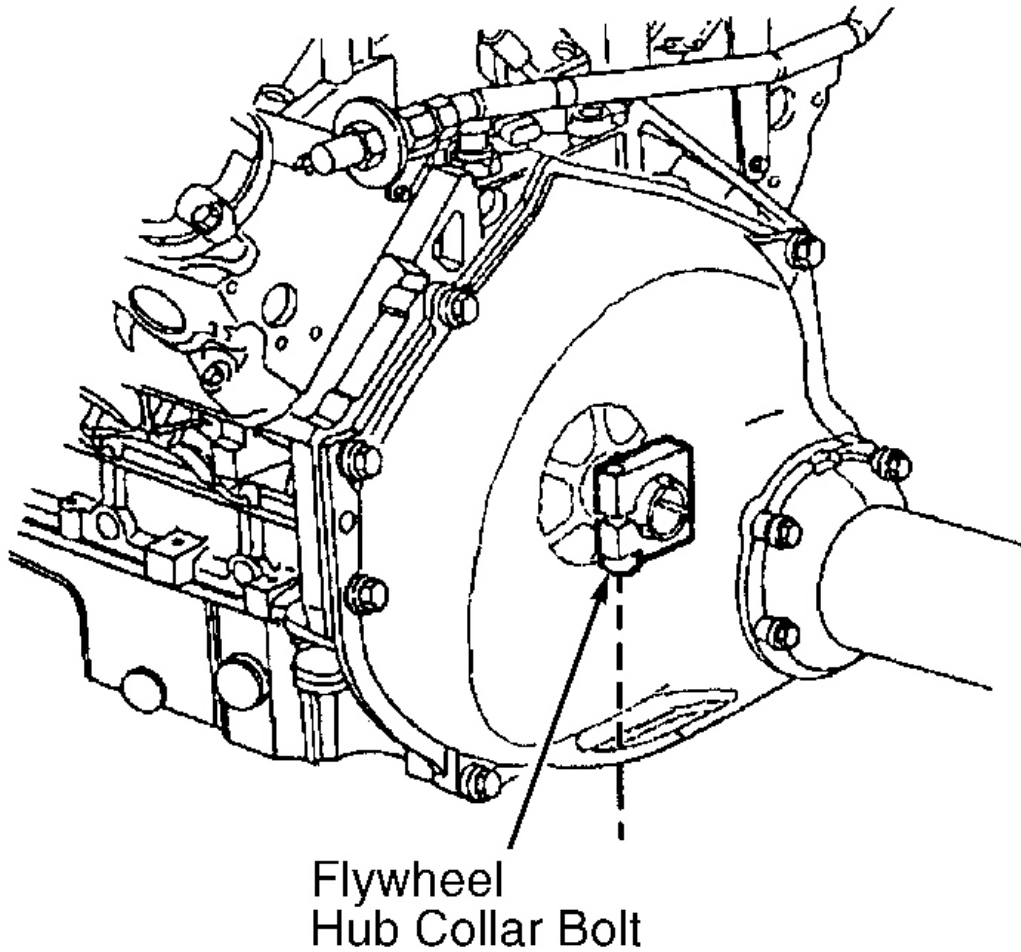

G98G12324

**Fig. 3: Loosening Flywheel Hub Collar Bolt.**  
Courtesy of GENERAL MOTORS CORP.

**CAUTION: Never support weight of engine by Driveline Support (J 42203)**

9. On all models, install driveline support to close-out panel flange. Partially lower vehicle. Support engine and front cradle on Engine Support Table (J 39580). Remove front cradle nuts. Partially lower engine and cradle.
10. Label and disconnect electrical connectors from engine oil pressure gauge, camshaft position sensor, MAP sensor and knock sensor. Disconnect ground on rear of left head, and



## 2001 Chevrolet Corvette

2000-01 ENGINES 5.7L V8 - Corvette

all remaining electrical connections.

11. Remove front driveline support assembly bolts. Slide engine and cradle assembly forward to clear drive shaft splines. Raise vehicle completely off of engine and cradle assembly.

**NOTE:**      **It is not necessary to open power steering system during engine removal.**

12. Remove P/S pump and reservoir, and wire to cradle. Remove engine mount-to-cradle nuts. Remove engine from cradle.

### Installation

To install, reverse removal procedure. Fill crankcase. Fill and bleed cooling system. See **COOLING SYSTEM BLEEDING** . Evacuate and recharge A/C system. On A/T equipped vehicles, leave flywheel hub collar bolt out on initial start-up. Idle or drive vehicle for at least 10 minutes. Look for coolant or oil leaks. Shut off engine and allow to cool to room temperature. Install hub collar bolt and tighten to specification. See **TORQUE SPECIFICATIONS** . Tighten all nuts and bolts to specification. See **TORQUE SPECIFICATIONS** .

### INTAKE MANIFOLD

**NOTE:**      **Ensure injector connectors are marked for installation reference prior to removal. Performance and emissions will be affected if injector connectors are not positioned correctly.**

### Removal

1. On 2000 models, disconnect negative battery cable. Drain cooling system. Disconnect IAT and MAF sensor connectors. Remove air intake duct and air cleaner assembly.
2. On 2001 models, drain cooling system. Remove throttle body. Remove fuel injectors.
3. On all models, remove fuel rail covers. Relieve fuel pressure. See **FUEL PRESSURE RELEASE** . Disconnect fuel lines from fuel rail. Remove vacuum and crankcase vent hoses. Remove throttle body coolant outlet hose from throttle body. Disconnect fuel injector connectors. Disconnect throttle position sensor connector. Disconnect knock sensor electrical connector. Label and disconnect all remaining electrical connectors. Remove knock sensor pigtail from fuel rail stop bracket. Remove PCV valve pipe from left and right valve covers. Remove intake manifold bolts, and fuel rail stop bracket. Note location of fuel rail ground strap for reassembly. Remove engine coolant air bleed hose from throttle body. Remove intake manifold bolts. Remove intake manifold.

## Installation

**CAUTION:** Ensure fuel rail stop bracket is installed onto engine assembly. Fuel rail stop bracket serves as a protective shield for fuel rail in event of a frontal crash. If fuel rail stop bracket is not installed, and vehicle is involved in a frontal crash, fuel could be sprayed, possibly causing a fire and personal injury from burns.

To install, reverse removal procedure. Tighten bolts to specification. See **TORQUE SPECIFICATIONS** . See **Fig. 4** . Fill and bleed cooling system. See **COOLING SYSTEM BLEEDING** .

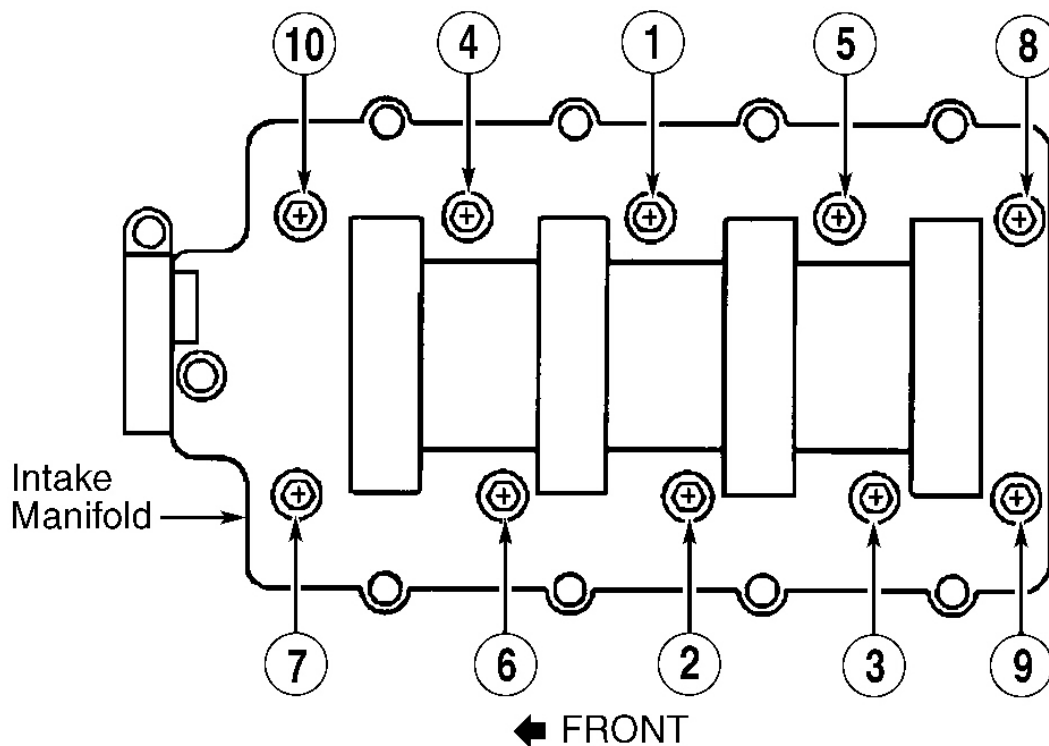

G97C03684

**Fig. 4: Intake Manifold Bolt Tightening Sequence**  
Courtesy of GENERAL MOTORS CORP.

EXHAUST MANIFOLD

## 2001 Chevrolet Corvette

2000-01 ENGINES 5.7L V8 - Corvette

### Removal (Left)

1. Disconnect negative battery cable. Raise and support vehicle. Remove left side intermediate pipe flange nuts from exhaust manifold studs. Remove oxygen sensor. Lower vehicle. Remove left-side fuel rail cover. Relieve fuel pressure. See **FUEL PRESSURE RELEASE** . Disconnect fuel lines from fuel rail. Remove generator rear bracket and bolts. Disconnect generator and coolant temperature sensor connectors.
2. Remove drive belt. Remove generator mounting bolts and generator. Remove air injection hose at air injection pipe. Remove air injection pipe bolts and gaskets from exhaust manifold, discard gaskets, and position pipe aside. Remove brake booster vacuum hose from brake booster. Remove spark plug wires from spark plugs and coils. Remove spark plugs. Remove exhaust manifold bolts, exhaust manifold and gasket.

### Removal (Right)

Raise and support vehicle. Remove flange nuts from exhaust manifold studs. Disconnect oxygen sensor. Lower vehicle. Remove air injection pipe bracket bolt from rear of left cylinder head. Remove air injection pipe, with check valve, from right exhaust manifold. Remove spark plug wires at spark plugs. Remove exhaust manifold bolts, exhaust manifold and gasket.

### Installation (Left & Right)

1. To install exhaust manifold(s), reverse removal procedure. Apply sealant to bolt threads.

**NOTE:** Do not apply sealant to first 3 threads of exhaust manifold bolts. Apply a .2" (5 mm) wide band of Threadlock (12345493) or equivalent to bolt threads.

2. Tighten nuts and bolts to specification. See **TORQUE SPECIFICATIONS** .

### VAPOR VENT PIPE

#### Removal & Installation

Remove intake manifold. See **INTAKE MANIFOLD** . Disconnect knock sensor wire harness retaining clips and position harness aside. Remove vapor vent pipe bolts, vent pipe and gaskets. To install, reverse removal procedure. Tighten nuts and bolts to specification. See **TORQUE SPECIFICATIONS** .

### ENGINE VALLEY COVER

#### Removal & Installation

## 2001 Chevrolet Corvette

2000-01 ENGINES 5.7L V8 - Corvette

Remove intake manifold. See **INTAKE MANIFOLD** . Remove vapor vent pipe. See **VAPOR VENT PIPE** . Unplug knock sensor connectors, and position knock sensor wiring harness aside. Remove engine valley cover bolts, and valley cover. To install, reverse removal procedure.

### CYLINDER HEADS

**CAUTION: Remove cylinder head when engine is completely cold.**

#### Removal (Right)

1. Drain coolant. Remove rocker arms, and pushrods. See **ROCKER ARMS & PUSHRODS** .
2. Remove vapor vent pipe. See **VAPOR VENT PIPE** . Remove exhaust manifold. See **EXHAUST MANIFOLD** . Remove cylinder head bolts and cylinder head.

#### Removal (Left)

1. Drain coolant. Remove rocker arms, and pushrods. See **ROCKER ARMS & PUSHRODS** .
2. Remove vapor vent pipe. See **VAPOR VENT PIPE** . Remove exhaust manifold. See **EXHAUST MANIFOLD** .
3. On 2000 models only, using Power Steering Pump Pulley Remover (J 25034-C), remove power steering pump pulley. Remove power steering pump and bracket.
4. On all models, remove wiring harness from cylinder head. Remove cylinder head bolts and cylinder head.

#### Inspection

See **CYLINDER HEAD** under OVERHAUL.

#### Installation

1. Clean cylinder head bolt holes and threads. DO NOT coat composition-type head gaskets with sealer. Install head gasket onto cylinder block. Install cylinder head.

**CAUTION: Do not reuse M11 cylinder head bolts. Install NEW M11 cylinder head bolts during reassembly. See Fig. 5 .**

2. Install NEW M11 cylinder head bolts. Apply a .2" (5 mm) band of Threadlock (12345493) to threads of M8 cylinder head bolts. Tighten M11 bolts to 22 ft. lbs. (30 N.m) in sequence.

Tighten M11 bolts an additional 90 degrees in sequence. Tighten M11 bolts 1-8 an additional 90 degrees in sequence, and M11 bolts 9 and 10 an additional 50 degrees. Tighten M8 bolts 11-15 in sequence to 22 ft. lbs. (30 N.m). See **Fig. 5** . To complete installation, reverse removal procedure. See **TORQUE SPECIFICATIONS** . Fill and bleed cooling system. See **COOLING SYSTEM BLEEDING** .

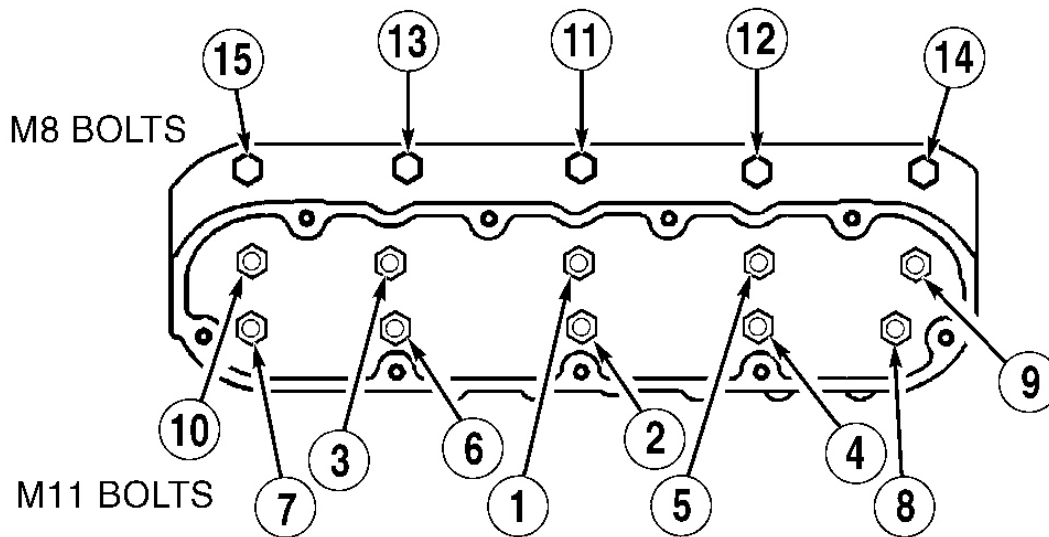

G97H03686

**Fig. 5: Cylinder Head Bolt Tightening Sequence**  
 Courtesy of GENERAL MOTORS CORP.

#### CRANKSHAFT FRONT OIL SEAL

**NOTE:** Front oil seal can be replaced without removing front cover.

#### Removal

1. Disconnect negative battery cable. Release accessory drive belt tensioner. Remove drive belt. Remove rack and pinion assembly. See appropriate POWER RACK & PINION article in STEERING. Remove starter. Remove power steering cooler from front crossmember, and position aside.
2. Release A/C belt tensioner, and remove belt. Note position of crankshaft balancer before removal. Mark or scribe end of balancer and crankshaft for installation reference. Remove crankshaft balancer. Carefully pry seal from timing cover.

## Installation

Install front oil seal into timing cover using Front Cover Seal Installer (J 41478). See **Fig. 6**. Reverse removal procedure.

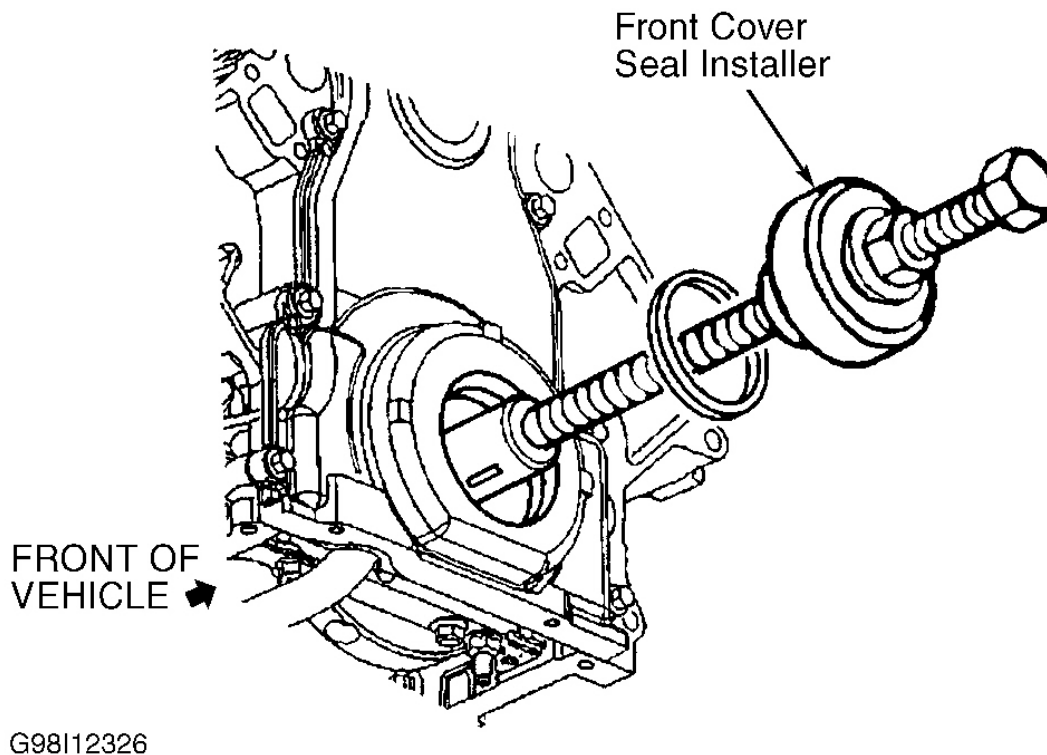

**Fig. 6: Installing Timing Cover Oil Seal**  
Courtesy of GENERAL MOTORS CORP.

## FRONT COVER

### Removal

Disconnect fuel regulator purge line from air intake duct. Remove air intake duct and air cleaner assembly. Drain coolant. Remove water pump. See **WATER PUMP**. Note position of crankshaft balancer before removal. Mark or scribe end of balancer and crankshaft for installation reference. Remove crankshaft balancer. Remove front cover-to-oil pan bolts. Remove front cover bolts, front cover and gasket.

### Installation

1. Apply a .2" (5 mm) bead of Sealer (12378190) onto corners where oil pan meets block. Install front cover, leaving bolts finger tight.

**NOTE:** Align tapered legs of Front/Rear Cover Aligner (J 41476) with machined alignment surfaces on front cover. See Fig. 7 .

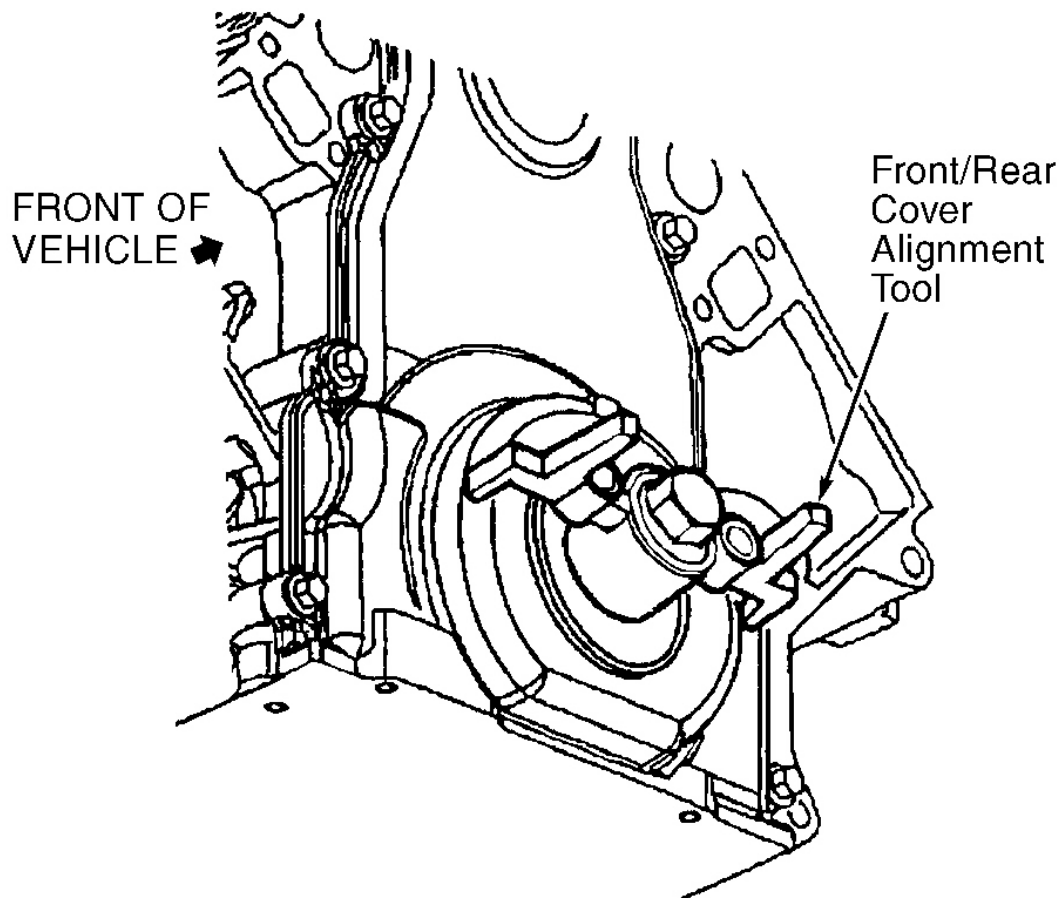

G98J12327

**Fig. 7: Installing Front Cover & Alignment Tool**  
Courtesy of GENERAL MOTORS CORP.

2. Install Front/Rear Cover Aligner onto front of crankshaft. Install and hand tighten crankshaft balancer bolt. Tighten front cover bolts. Tighten oil pan-to-front cover and oil pan-to-block bolts. Tighten oil pan-to-rear cover bolts. See **TORQUE SPECIFICATIONS** . Remove tool from front of crankshaft. Install NEW front seal into cover using Front Crankshaft Oil Seal Installer (J 41478). To complete installation, reverse

removal procedure. Fill crankcase. Fill and bleed cooling system. See **COOLING SYSTEM BLEEDING**.

### CRANKSHAFT REAR OIL SEAL

**NOTE:** Rear oil seal can be replaced without removing rear oil seal cover.

#### Removal

Remove transmission. For A/T, see appropriate TRANSMISSION REMOVAL & INSTALLATION article in TRANSMISSION SERVICING. For M/T, see appropriate article in CLUTCHES. Note position of flywheel before removal. Mark or scribe end of flywheel for installation reference. Remove flywheel. Remove rear crankshaft oil seal, and discard.

#### Installation

Install rear seal using Rear Seal Installer (J 41479). See **Fig. 8**. Reinstall flywheel and transmission. Tighten bolts to specification. See **TORQUE SPECIFICATIONS**.

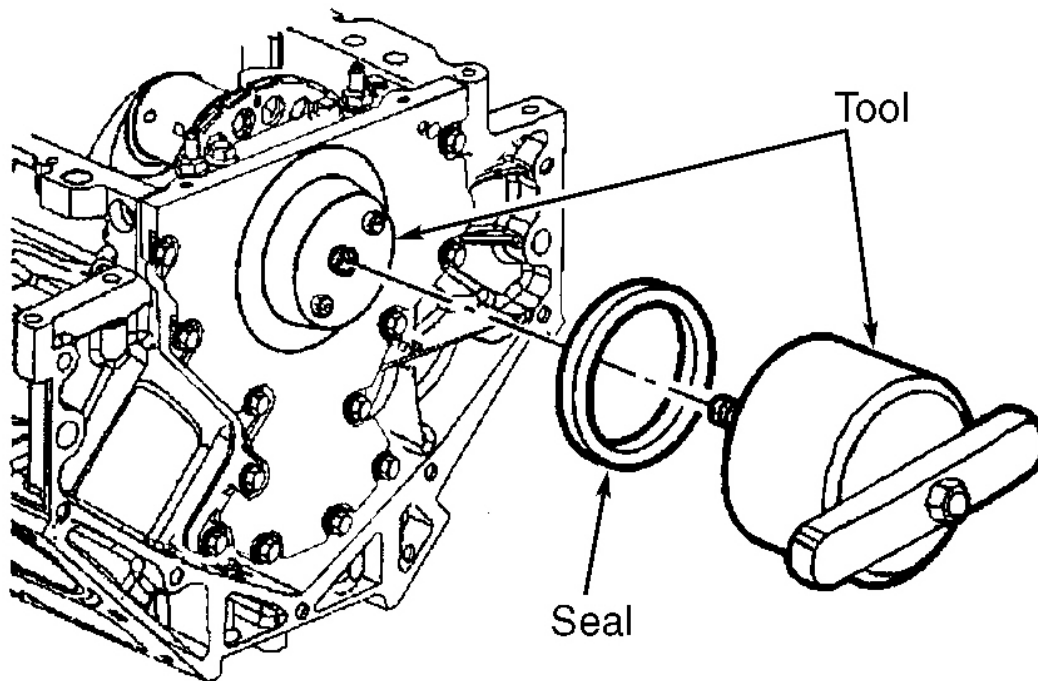

G97F03690



**Fig. 8: Installing Crankshaft Rear Oil Seal.**  
**Courtesy of GENERAL MOTORS CORP.**

**REAR COVER**

**Removal**

Remove transmission and flywheel. See **CRANKSHAFT REAR OIL SEAL** . Remove rear cover-to-block bolts. Loosen oil pan bolts. Remove rear cover and gasket. Remove rear seal from cover, and discard.

**Installation**

1. Apply a .2" (5 mm) bead of Sealer (12378190) to corners where oil pan meets block. Install rear cover and NEW gasket, leaving bolts finger tight. Rotate crankshaft until 2 opposing flywheel bolts are parallel to oil pan surface. See **Fig. 9** .
2. Install Front/Rear Cover Aligner (J 41476) onto rear of crankshaft. Tighten aligner retaining bolts until snug. Tighten rear cover-to-block bolts, oil pan-to-rear cover bolts, oil pan-to-front cover, and oil pan-to-block bolts to to specification. See **TORQUE SPECIFICATIONS** . Remove front/rear cover alignmer from crankshaft. Install NEW rear seal using Rear Oil Seal Installer (J 41479). Reinstall flywheel and transmission. Tighten bolts to specification. See **TORQUE SPECIFICATIONS** .

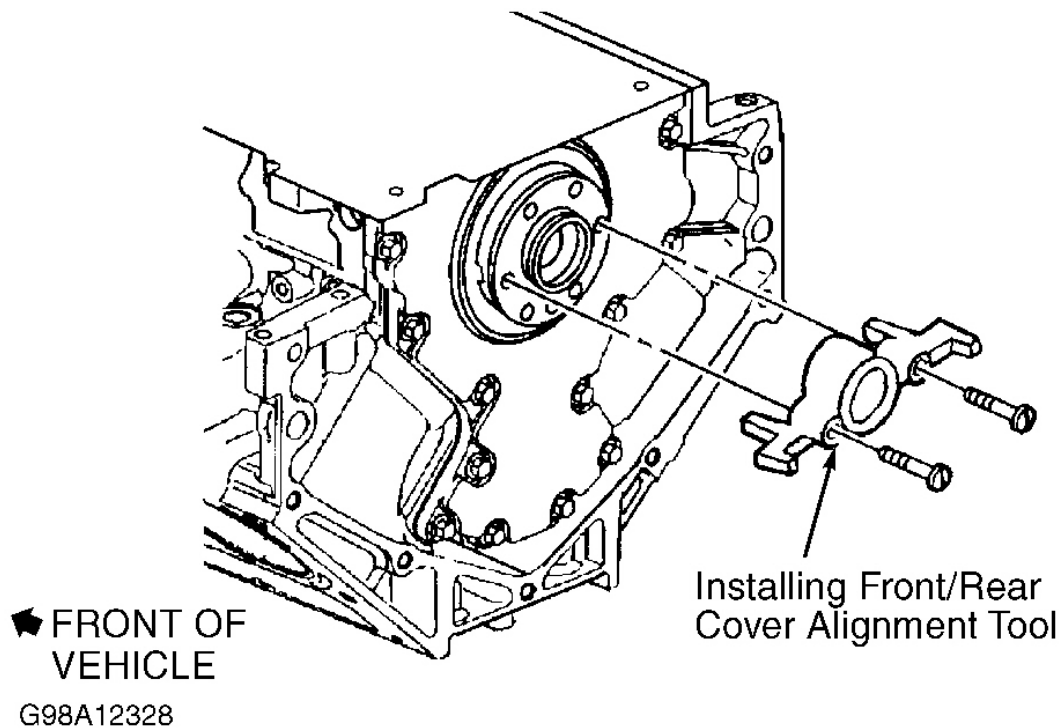
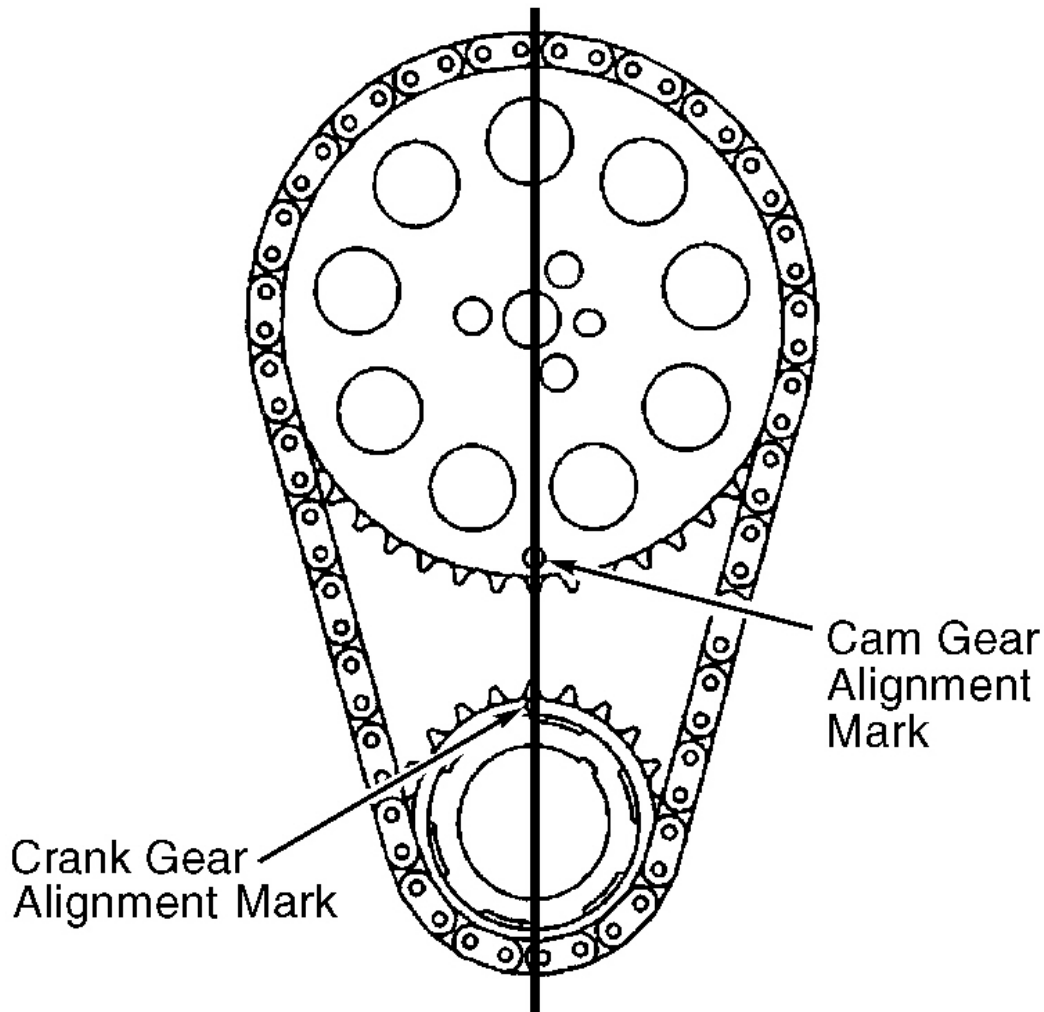

**Fig. 9: Installing Front/Rear Cover Alignment Tool**  
Courtesy of GENERAL MOTORS CORP.

## TIMING CHAIN

### Removal & Installation

1. Disconnect negative battery cable. Remove crankshaft balancer and front cover. See **FRONT COVER** . Remove oil pan. See **OIL PAN** . Remove oil pump. See **OIL PUMP** . Rotate crankshaft until camshaft sprocket and crankshaft sprocket timing marks line up with shaft centers. See **Fig. 10** .
2. Remove timing chain and camshaft sprocket. If replacing crankshaft sprocket, use Sprocket Remover (J 41558), and Sprocket Installer (J 41665). Ensure timing marks on crankshaft sprocket and camshaft sprocket are as close together as possible, and lined up with shaft centers.
3. To complete installation, reverse removal procedure. Fill crankcase. Fill and bleed cooling system. See **COOLING SYSTEM BLEEDING** .



G98B12329

**Fig. 10: Identifying Timing Chain Alignment Marks**  
Courtesy of GENERAL MOTORS CORP.

## VALVE COVERS

### Removal (Left)

1. Disconnect negative battery cable. Remove left side fuel rail cover, if equipped. Relieve fuel pressure. See **FUEL PRESSURE RELEASE** . Disconnect fuel lines from fuel rail. Disconnect generator and coolant temperature sensor connectors. Disconnect brake booster hose from brake booster. Disconnect PCV hose from valve cover. Remove spark plug wires

## 2001 Chevrolet Corvette

2000-01 ENGINES 5.7L V8 - Corvette

at coils. Disconnect ignition coil main connector. Disconnect any interfering air injection hoses.

2. Remove generator rear bracket and bolts. Disconnect pipes from EVAP purge solenoid. Remove purge solenoid from intake manifold. Remove valve cover bolts, valve cover and gasket.

### Removal (Right)

Disconnect negative battery cable. Remove right-side fuel rail cover, if equipped. Remove crankcase vent hose. Remove air injection pipe (with check valve) from exhaust manifold, if equipped. Disconnect ignition coil harness main connector. Remove spark plug wires from ignition coils. Remove valve cover bolts, valve cover and gasket.

### Installation

To install, reverse removal procedure. Tighten bolts and nuts to specification. See **TORQUE SPECIFICATIONS** .

## ROCKER ARMS & PUSH RODS

### Removal

Remove valve covers. See **VALVE COVERS** . Mark components for installation into original locations. Remove rocker arm bolts, rocker arms, rocker arm pivot support and push rods.

### Installation

1. Lubricate rocker arms and pushrods with clean engine oil. Lubricate flange of rocker arm bolt and any contacting surfaces. Install rocker arm pivot support. Install pushrods, making sure they seat properly into lifter sockets. Install rocker arms and bolts. DO NOT fully tighten bolts at this time.

**CAUTION: Rocker arm bolts must be tightened to specification with appropriate piston at TDC of compression stroke to avoid damage to valve train.**

2. Rotate crankshaft so No. 1 piston is at TDC of compression stroke. Tighten rocker arms in order listed. See **ROCKER ARM TIGHTENING SEQUENCE** table. Tighten to specification. See **TORQUE SPECIFICATIONS** .
3. Rotate crankshaft so No. 6 piston is at TDC of compression stroke. Tighten appropriate rocker arms. To complete installation, reverse removal procedure. Tighten bolts and nuts to

## 2001 Chevrolet Corvette

2000-01 ENGINES 5.7L V8 - Corvette

specification. See **TORQUE SPECIFICATIONS** .

### ROCKER ARM TIGHTENING SEQUENCE

Application	Cylinders No.
Cylinder No. 1 <sup>(1)</sup>	
Exhaust	1, 2, 7 & 8
Intake	1, 3, 4 & 5
Cylinder No. 6 <sup>(1)</sup>	
Exhaust	3, 4, 5 & 6
Intake	2, 6, 7 & 8
(1) Piston at TDC of compression stroke.	

### VALVE LIFTERS

#### Removal

**NOTE:** Some valve lifters may be stuck in their bores due to gum or varnish deposits. Use Valve Lifter Remover (J 3049-A) to remove valve lifter.

Disconnect negative battery cable. Remove intake manifolds. See **INTAKE MANIFOLD** . Remove exhaust manifolds. See **EXHAUST MANIFOLD** Remove valve covers. See **VALVE COVERS** . Remove rocker arms and push rods. See **ROCKER ARMS & PUSH RODS** . Remove cylinder heads. See **CYLINDER HEADS** . Remove valve lifter guide bolts, and remove valve lifters and guide. Note location of each lifter and lifter guide for reassembly.

#### Inspection

**NOTE:** If sides of lifter are worn, inspect lifter bores for wear or damage.

Thoroughly clean lifters in cleaning solvent, and dry with compressed air. Inspect lifters for bent or broken clips, worn push rod sockets, worn sides, flat spots on roller, loose or damaged pin, plugged oil hole and damaged roller bearings. Inspect valve lifter guides for damage or excessive wear in lifter mounting bores.

#### Installation

Lubricate lifters and cylinder block lifter bores with engine oil. Insert lifters into lifter guides, aligning flat area on top of lifter with flat area in lifter guide. Push lifter completely into lifter

## 2001 Chevrolet Corvette

2000-01 ENGINES 5.7L V8 - Corvette

guide bore. Install valve lifter and guide assembly into original location in cylinder block, and install lifter guide bolt. To complete installation, reverse removal procedure. Tighten bolts to specification. See **TORQUE SPECIFICATIONS** .

### CAMSHAFT

**NOTE:** It is necessary to remove cylinder heads on this engine for lifter removal.

**WARNING:** Rotate crankshaft in direction of normal operation only.

### Removal

1. Remove valve covers and rocker arms. DO NOT remove push rods. Keep components in order for installation reference. See **VALVE COVERS** and **ROCKER ARMS & PUSH RODS** . Measure lobe lift of camshaft with push rods installed.
2. To measure lobe lift, attach dial indicator to cylinder head. Position indicator pointer onto tip of a push rod. Rotate crankshaft until push rod is at lowest point. Zero indicator. Rotate crankshaft until push rod is at highest point. Record reading, and repeat procedure for remaining lobes.
3. Remove cylinder heads. See **CYLINDER HEADS** . Remove oil pan. See **OIL PAN** . Remove front cover, oil pump and timing chain. See **TIMING CHAIN** . Remove camshaft sensor bolt and sensor. Remove camshaft retaining plate. Remove lifter guide bolts. Remove lifter guide and valve lifters. Using three 5/16" x 18 x 4" bolts as a handle, carefully pull camshaft from engine.

### Inspection

Check camshaft for scratches, pits and loose fit in bearings. Check camshaft journal diameter and lobe lift, recorded earlier. Replace camshaft if damaged, or not to specification. See **CAMSHAFT SPECIFICATIONS** table under ENGINE SPECIFICATIONS. If replacing camshaft, replace lifters.

### Installation

Apply Camshaft Prelube (1052365) onto camshaft lobes. Apply engine oil onto bearings and camshaft bearing journals. Change engine oil and filter. To complete installation, reverse removal procedure. Tighten bolts and nuts to specification. See **TORQUE SPECIFICATIONS** . Fill and bleed cooling system. See **COOLING SYSTEM BLEEDING** .

## WATER PUMP

### Removal

Disconnect negative battery cable. Disconnect IAT and MAF sensor connectors. Remove fuel regulator purge line from air intake duct. Remove air intake duct. Remove air cleaner assembly. Remove accessory drive belts. Drain coolant. Disconnect radiator and heater hoses at water pump. Remove water pump pulley. Remove water pump bolts, water pump and gasket.

### Installation

To install, reverse removal procedure. Use NEW gasket. Fill and bleed cooling system. See **COOLING SYSTEM BLEEDING** . Tighten bolts and nuts to specification. See **TORQUE SPECIFICATIONS** .

## OIL PAN

**CAUTION: Alignment of oil pan is critical. Oil pan has mounting points for transmission bellhousing. It is important that oil pan and rear of block/rear seal cover are flush, and that rear of oil pan does not protrude beyond engine block.**

### Removal

1. Disconnect negative battery cable. Remove generator from mounting bracket, and wire aside. Support engine using Engine Support Fixture (J 41803). Raise and support vehicle. Remove front wheels. Remove tie rod end nuts. Remove tie rod ends from steering knuckles using Ball Joint Separator (J 42188).
2. Remove front stabilizer bar bolts and straps. Disconnect front stabilizer bar from cradle. Remove P/S cooler bolts from cradle. Disconnect P/S cooler from cradle, and wire aside. Remove P/S gear bolts. Remove P/S gear from cradle, and wire aside.
3. Using Spring Compressor (J 33432-A), compress front transverse spring. See **Fig. 1** . Remove lower shock absorber bolts. Remove lower ball joint nuts. Separate lower ball joints using ball joint separator. Remove spring compressor from front spring. Disconnect all electrical wiring from crossmember. Remove motor mount-to-crossmember bolts. Support crossmember with a transmission jack. Remove crossmember bolts and crossmember.
4. Drain crankcase. Remove oil filter. Remove A/T cooler line bracket bolts, if equipped. Remove flywheel housing-to-oil pan bolts. Remove flywheel housing cover bolts. Disconnect oil level sensor and remove. Disconnect engine oil temperature sensor connector. Remove remaining oil pan bolts, oil pan and gasket.

## 2001 Chevrolet Corvette

2000-01 ENGINES 5.7L V8 - Corvette

### Installation

Install Front/Rear Cover Aligner (J 41480) to check for proper alignment of front and rear covers. If it is necessary to realign covers, see **FRONT COVER** and **REAR COVER** for alignment procedures. Apply a .2" (5 mm) bead of Sealant (12378190) where front and rear covers meet block. Install oil pan with NEW oil pan gasket. Tighten oil pan-to-front cover, oil pan-to-block bolts and oil pan-to-rear cover bolts to specification. See **TORQUE SPECIFICATIONS** . To complete installation, reverse removal procedure. Fill crankcase. Align front suspension as necessary. See appropriate SPECIFICATIONS & PROCEDURES article in WHEEL ALIGNMENT. Tighten bolts and nuts to specification. See **TORQUE SPECIFICATIONS** .

### OVERHAUL

**NOTE:** For repair procedures not covered in this article, see **ENGINE OVERHAUL PROCEDURES** article in **GENERAL INFORMATION**.

### CYLINDER HEAD

#### Valve Guides

Check and service guides before servicing valve and seat. Guide replacement information not available at time of publication. If valve stem clearance is .0037" (.093 mm) or more, valve and/or guide must be repaired or replaced.

#### Valve Seat

Valve seat replacement information not available at time of publication. Valve seat runout should not exceed .002" (.05 mm). Follow instructions of tool manufacturer for servicing valve seats. If seats are serviced, service or replace valves.

#### Valves

Check valves before servicing. Replace valves as necessary. DO NOT reface intake valves. See **VALVES & VALVE SPRINGS SPECIFICATIONS** table under ENGINE SPECIFICATIONS. Exhaust valve face may be machined if margin is .050" (1.25 mm) or more prior to grinding.

### CYLINDER BLOCK ASSEMBLY

#### Piston & Rod Assembly



## 2001 Chevrolet Corvette

2000-01 ENGINES 5.7L V8 - Corvette

1. Before disassembling, mark rod and rod cap with matching cylinder number. Mark piston-to-rod relationship for reassembly reference. Notch or dot on piston top should face front of engine. Piston pin is a press fit.
2. When measuring, ensure pin bore and piston pin are free of varnish and scuffing. If clearance between piston and pin exceeds specification, replace piston and pin as an assembly. See **PISTONS, PINS & RINGS SPECIFICATIONS** table under ENGINE SPECIFICATIONS.
3. Connecting rods are made of powdered metal, and are not repairable. Inspect rod bolt hole threads and mating surfaces, and rod bore for out-of-round condition. Check for rod twist, nicks, gouging and any other damage. If any damage exists, replace rod.

### Fitting Pistons

Ensure notch or dot on piston top faces front of engine. Check pistons for wear and damage. Replace pistons as necessary. Check piston-to-cylinder bore clearance. A .010" (.25 mm) oversize piston is available.

### Piston Rings

Install marked side of ring toward top of piston. Ensure end gaps are evenly spaced on piston. See **Fig. 11** .

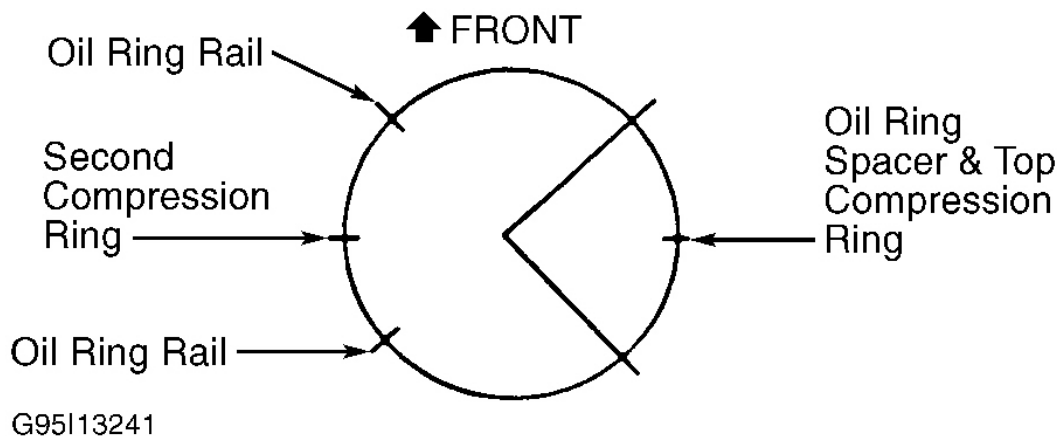

**Fig. 11: Positioning Piston Ring End Gaps**  
Courtesy of GENERAL MOTORS CORP.

### Rod Bearings

Ensure bearing cap bolt holes and mating surfaces are clean and dry. Use connecting rod stud protectors on rod cap bolts. Install inserts into connecting rod and cap. Lubricate bearings and crank pin. Install bearing cap. Tighten rod bearing cap bolts to specification. See **TORQUE SPECIFICATIONS** .

### Crankshaft & Main Bearings

1. Remove bearing cap M8 side bolts prior to cap removal. Remove bearing cap M10 bolts and studs. Install Crankshaft Bearing Cap Remover (J 41818) onto bearing cap. Tighten bearing cap remover bolts to 100 INCH lbs. (11 N.m). Install Slide Hammer (J 6125-1B) to bearing cap remover to remove cap. If bearing clearance is greater than specification, replace with undersize bearings. Recheck bearing clearance using Plastigage. Install NEW M8 main cap side bolts. Tighten main bearing cap bolts to initial torque in sequence. See **Fig. 12** . See **TORQUE SPECIFICATIONS** .

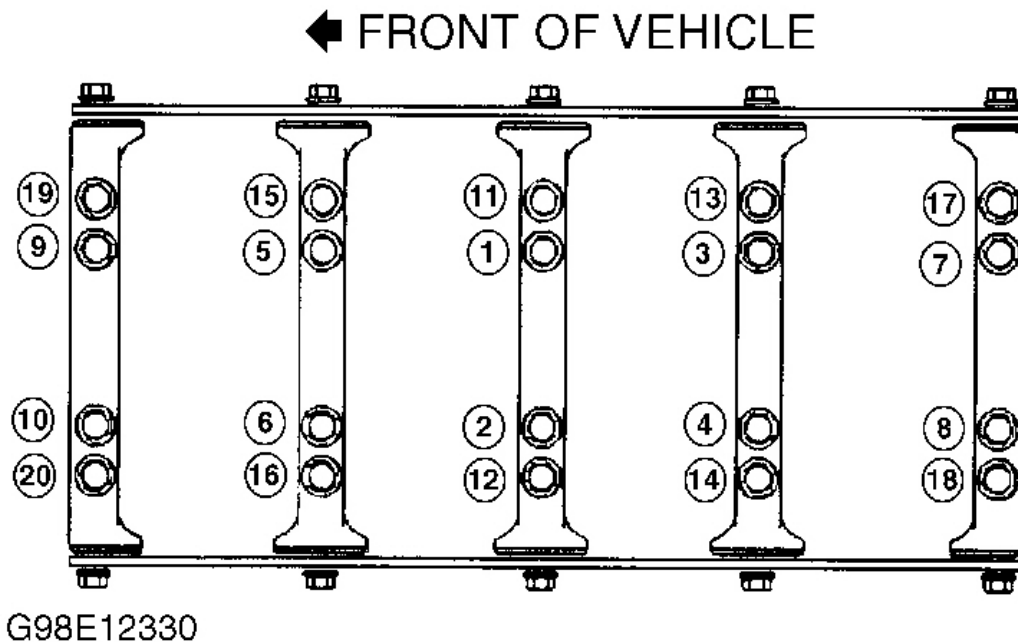

**Fig. 12: Main Cap Bolt Tightening Sequence**  
 Courtesy of GENERAL MOTORS CORP.

2. Tighten main bearing cap bolts finger tight. Pry crankshaft rearward and then forward to align rear main bearing thrust surfaces. Retighten main bearing caps to specification. See

## **TORQUE SPECIFICATIONS .**

### **Thrust Bearing**

Check crankshaft end play by forcing crankshaft to extreme forward position. Measure end play at front of rear main bearing using a feeler gauge. If end play is not within specification, replace thrust bearing and/or crankshaft. See **CRANKSHAFT, MAIN & CONNECTING ROD BEARINGS SPECIFICATIONS** table under ENGINE SPECIFICATIONS.

### **Cylinder Block**

Check cylinder bore for wear, taper, out-of-round and piston fit. See **CYLINDER BLOCK SPECIFICATIONS** table under ENGINE SPECIFICATIONS. Cylinders with less than .010" (.25 mm) wear or taper can be honed. A .010" (.25 mm) oversize piston and ring set is available for service. Cylinders with more than .010" (.25 mm) wear or taper are not serviceable. DO NOT bore engine.

## **ENGINE OILING**

### **ENGINE LUBRICATION SYSTEM**

A gerotor-type oil pump provides pressurized lubrication through full-flow oil filter. Oil pump is bolted to front of cylinder block, behind front cover, and is driven directly by crankshaft. See **Fig. 13** .

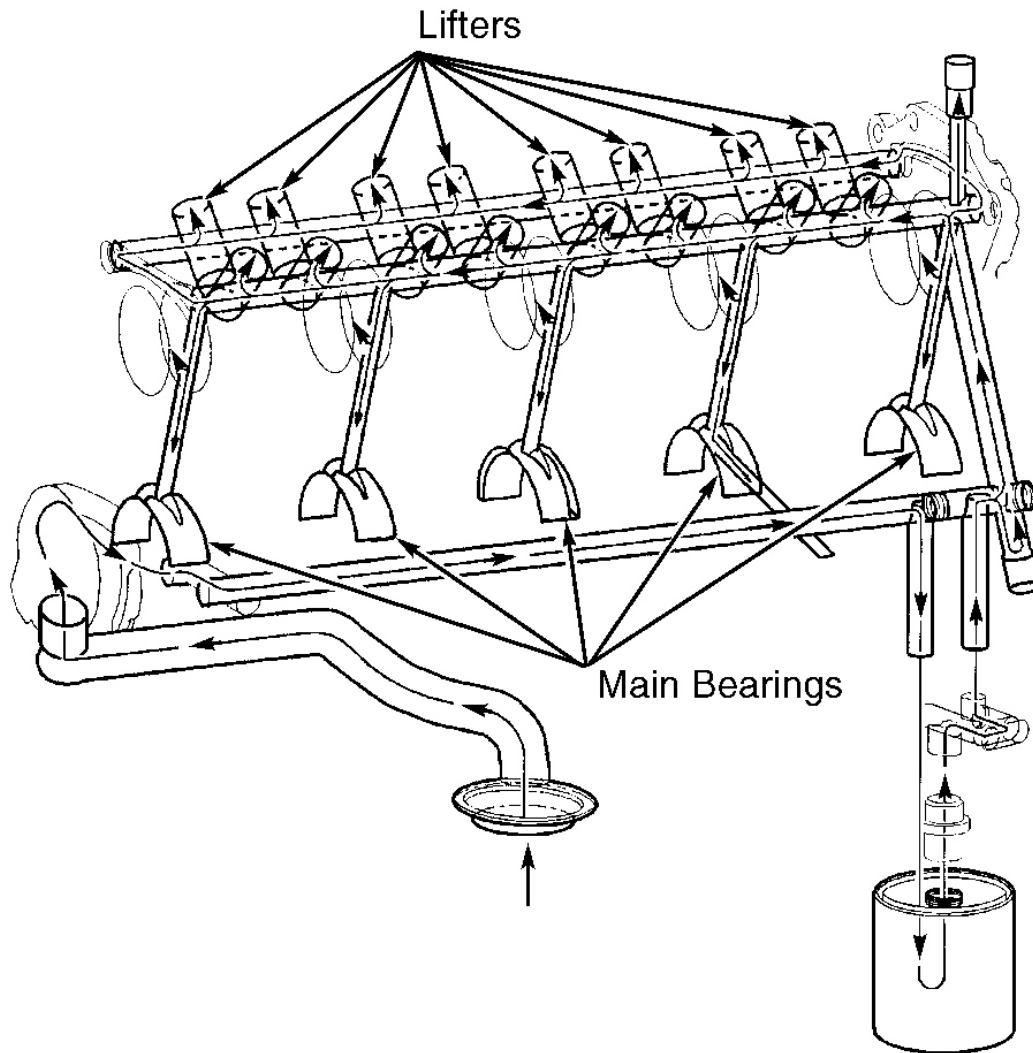

G97D03694

**Fig. 13: Identifying Lubrication System**  
Courtesy of GENERAL MOTORS CORP.

**Oil Capacity**

Crankcase capacity is 6.0 qts. (5.7L) without oil filter change, or 6.5 qts. (6.2L) with oil filter change.

**Oil Pressure**

With engine at normal operating temperature, oil pressure should be at least 6 psi (0.4 kg/cm<sup>2</sup>) at

## 2001 Chevrolet Corvette

2000-01 ENGINES 5.7L V8 - Corvette

1000 RPM, 18 psi (1.3 kg/cm<sup>2</sup>) at 2000 RPM and 24 psi (1.7 kg/cm<sup>2</sup>) at 4000 RPM.

### OIL PUMP

#### Removal & Disassembly

Remove front cover. See **FRONT COVER** under REMOVAL & INSTALLATION. Remove oil pan. See **OIL PAN** under REMOVAL & INSTALLATION. Remove oil pump, pump pick-up screen and deflector. Remove oil pump cover bolts and cover. Mark gear teeth for reassembly reference. Remove gears. Remove pressure regulator plug, spring and valve from cover. Remove pick-up screen and pipe.

#### Inspection

Check oil pump housing and cover for cracks, wear, scoring and casting imperfections. Check oil pump housing-to-engine block oil gallery surface for scratches or gouging. If excess wear or damage is found, replace oil pump as an assembly. Oil pump clearance specifications not available at time of publication. Inspect pump screen for debris or restrictions. Inspect pump screen for broken or loose wire mesh. Oil pump pipe and pick-up screen are to be serviced as an assembly. DO NOT attempt to repair pipe and pick-up screen assembly.

#### Reassembly & Installation

Clean parts in solvent. Dry parts using compressed air. To assemble, reverse disassembly procedure. To install, reverse removal procedure. Tighten oil pump cover bolts to specification. See **TORQUE SPECIFICATIONS**.

### TORQUE SPECIFICATIONS

#### TORQUE SPECIFICATIONS

Application	Ft. Lbs. (N.m)
Air Injection Pipe-To-Exhaust Manifold Bolts	15 (20)
Camshaft Retainer Bolt	18 (24)
Camshaft Sensor Bolt	18 (24)
Camshaft Sprocket Bolt	26 (35)
Connecting Rod Cap Bolts	
First Design	
Step 1	15 (20)
Step 2	Additional 60 Degrees

## 2001 Chevrolet Corvette

2000-01 ENGINES 5.7L V8 - Corvette

Second Design	
Step 1	15 (20)
Step 2	Additional 75 Degrees
Crankshaft Balancer Bolt	
With Original Bolt To Seat Balancer	240 (325)
Step 1 With New Bolt	37 (50)
Step 2 With New Bolt	Additional 140 Degrees
Crankshaft Oil Deflector Nuts	18 (24)
Crankshaft Oil Seal Cover To Block Bolt (Front & Rear)	18 (24)
Crankshaft Position Sensor Bolts	18 (24)
Cylinder Head Bolts	(1)
Drive Belt Idler Pulley Bolt	37 (50)
Drive Belt Tensioner Bolt	37 (50)
Engine Mount Bracket Bolt	37 (50)
Engine Mount Nut	48 (65)
Engine Mount-to-Engine Mount Bracket Nut	48 (65)
Exhaust Manifold Bolts	
Step 1	11 (15)
Step 2	18 (24)
Flexplate/Flywheel-To-Crankshaft Bolts <sup>(2)</sup>	
Step 1	15 (20)
Step 2	37 (50)
Step 3	74 (100)
Flywheel Hub Collar Bolt (A/T)	96 (130)
Knock Sensors	15 (20)
Main Bearing Cap <sup>(3)</sup>	
Inner Bolts	
Step 1	15 (20)
Step 2	Additional 80 Degrees
Outer Studs	
Step 1	15 (20)

## 2001 Chevrolet Corvette

2000-01 ENGINES 5.7L V8 - Corvette

Step 2	Additional 53 Degrees
Side Bolts	18 (24)
Oil Pan	
M6 Bolts	(4)
M8 Bolts	18 (24)
Oil Pump Screen Nuts	18 (24)
Oil Pump Screen-To-Oil Pump Bolt	(4)
Oil Pump-To-Block Bolt	18 (24)
Oxygen Sensor	30 (41)
Rocker Arm Bolts	22 (30)
Spark Plugs	12 (16)
Starter Bolts	37 (50)
Transmission-To-Driveline Support Assembly Bolts	37 (50)
Valley Cover Bolts	18 (24)
Valve Lifter Guide Bolts	18 (24)
Water Pump Bolts	
Step 1	11 (15)
Step 2	22 (30)
Water Pump Cover Bolts	11 (15)
Water Pump Pulley Bolt	
Step 1	(5)
Step 2	18 (24)
<b>INCH Lbs. (N.m)</b>	
Flywheel Cover Bolts	106 (12)
Fuel Rail Bolts	89 (10)
Ignition Coil Bolts	106 (12)
Intake Manifold Bolts <sup>(6)</sup>	
Step 1	44 (5)
Step 2	89 (10)
Oil Level Sensor	116 (13)
Oil Pump Cover Bolts	106 (12)
Throttle Body Bolts	106 (12)
Valve Cover Bolts	106 (12)

## 2001 Chevrolet Corvette

2000-01 ENGINES 5.7L V8 - Corvette

Valve Lifter Guide Bolts	106 (12)
Vapor Vent Pipe Bolts	106 (12)

(1) See INSTALLATION under **CYLINDER HEADS** for procedure and specifications.

See **Fig. 5** .

(2) Tighten bolts evenly using a crisscross sequence.

(3) Tighten bolts in sequence. See **Fig. 12** .

(4) Tighten to 106 INCH lbs. (12 N.m)

(5) Tighten to 78 INCH lbs. (8.9 N.m)

(6) Tighten bolts in sequence. See **Fig. 4** .

## ENGINE SPECIFICATIONS

### GENERAL SPECIFICATIONS

Application	Specification
Displacement	350 Cu. In. (5.7L)
Bore	3.898" (99.00 mm)
Stroke	3.622" (92.00 mm)
Compression Ratio	
LS1	10.1:1
LS6	10.5:1

### CRANKSHAFT, MAIN & CONNECTING ROD BEARINGS SPECIFICATIONS

Application	In. (mm)
Crankshaft	
End Play	.0015-.0078 (.04-.22)
Runout At Rear Flange (Maximum)	.0020 (.050)
Main Bearings	
Journal Diameter	2.558-2.559 (64.993-65.007 )
Journal Out-Of-Round	
Standard	.0001 (.003)
Wear Limit	.0003 (.008)
Journal Taper	



**2001 Chevrolet Corvette**

2000-01 ENGINES 5.7L V8 - Corvette

Standard	.0004 (.010)
Wear Limit	.0008 (.020)
<b>Reluctor Ring</b>	
Runout <sup>(1)</sup>	.010 (.25)
Oil Clearance	.0007-.0021 (.018-.054)
<b>Connecting Rod Bearings</b>	
Journal Diameter	2.0991-2.0999 (53.318-53.338)
<b>Journal Out-Of-Round</b>	
Standard	.0002 (.005)
Wear Limit	.0004 (.010)
<b>Journal Taper <sup>(2)</sup></b>	
Standard	.0002 (.005)
Wear Limit	.0004 (.010)
Oil Clearance	.0009-.0025 (.023-.065 )
(1) Measured .40" (1 mm) below tooth diameter	
(2) Maximum for half of journal length.	

**CONNECTING RODS SPECIFICATIONS**

<b>Application</b>	<b>In. (mm)</b>
Bearing Bore Diameter	2.224-2.225 (56.50-56.52)
Maximum Bend	(1)
Maximum Twist	(1)
Side Play	.004-.020 (.11-.51)
(1) Replace rod if any bend or twist exists.	

**PISTONS, PINS & RINGS SPECIFICATIONS**

<b>Application</b>	<b>In. (mm)</b>
<b>Piston Clearance</b>	
Standard	.0007-.0021 (.018-.054)
Wear Limit	.0007-.0021 (.018-.054)

**2001 Chevrolet Corvette**

2000-01 ENGINES 5.7L V8 - Corvette

**Pins**

Diameter	.9447-.9448 (23.997-24.000)
Rod Fit (Interference)	.0008-.0017 (.020-.043)
<b>Rings</b>	
No. 1	
End Gap	.009-.015 (.23-.38)
Side Clearance	.00157-.00335 (.040-.085)
No. 2	
End Gap	.0017-.0025 (.044-.064)
Side Clearance	.00157-.00315 (.040-.080)
No. 3 (Oil)	
End Gap	.0070-.0271 (.178-.688)
Side Clearance	.0004-.0087 (.010-.220)

**CYLINDER BLOCK SPECIFICATIONS**

<b>Application</b>	<b>In. (mm)</b>
<b>Cylinder Bore</b>	
Diameter	3.897-3.898 (99.000-99.018)
Taper (Thrust Side)	.0007 (.018)

**VALVES & VALVE SPRINGS SPECIFICATIONS**

<b>Application</b>	<b>Specification</b>
<b>Valves</b>	
Face Angle	45°
Margin (Minimum)	.050" (1.25 mm)
Stem Diameter	.313-.314" (7.955-7.976 mm)
<b>Valve Springs</b>	
Free Length	
Except LS6	2.08" (52.90 mm)
LS6	2.10" (53.40 mm)
Installed Height	1.80" (45.75 mm)

**2001 Chevrolet Corvette**

2000-01 ENGINES 5.7L V8 - Corvette

		<b>Lbs. @ In. (N @ mm)</b>
Valve Spring Pressure		
Except LS6		
Valve Closed		76 @ 1.80 (340 N @ 45.75)
Valve Open		220 @ 1.32 (980 N @ 33.55)
LS6		
Valve Closed		90 @ 1.80 (400 N @ 45.75)
Valve Open		259 @ 1.28 (1150N @ 32.42)

**CYLINDER HEAD SPECIFICATIONS**

<b>Application</b>	<b>Specification</b>
Valve Seats	
Intake Valve	
Seat Angle	46°
Seat Width	.040" (1.02 mm)
Exhaust Valve	
Seat Angle	46°
Seat Width	.070" (1.78 mm)
Valve Guides	
Stem-To-Guide Oil Clearance	
Standard	.0010-.0026" (.025-.066 mm)
Wear Limit	.0037" (.093 mm)

**CAMSHAFT SPECIFICATIONS**

<b>Application</b>	<b>In. (mm)</b>
End Play	.001-.012 (.025-.305)
Journal Diameter	2.164-2.166 (54.99-55.04)
Lobe Lift	
2000	
Intake	.277 (7.04)
Exhaust	.281 (7.13)

**2001 Chevrolet Corvette**

2000-01 ENGINES 5.7L V8 - Corvette

2001

LS1

Intake .274 (6.96)

Exhaust .281 (7.13)

LS6

Intake .306 (7.78)

Exhaust .306 (7.78)