

2002 Toyota Celica GT-S L4-1.8L (2ZZ-GE)

Vehicle » Engine, Cooling and Exhaust » Engine » Valve Clearance » Adjustments

ADJUSTMENT

HINT: Inspect and adjust the valve clearance when the engine is cold.

1. REMOVE CYLINDER HEAD COVER
2. SET NO. 1 CYLINDER TO TDC/COMPRESSION

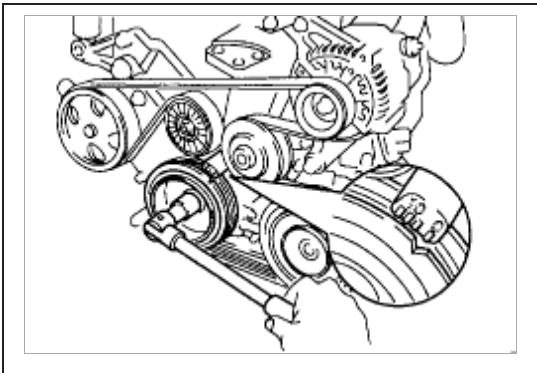

- a. Turn the crankshaft pulley, and align its groove with the timing mark "0" of the timing chain cover.

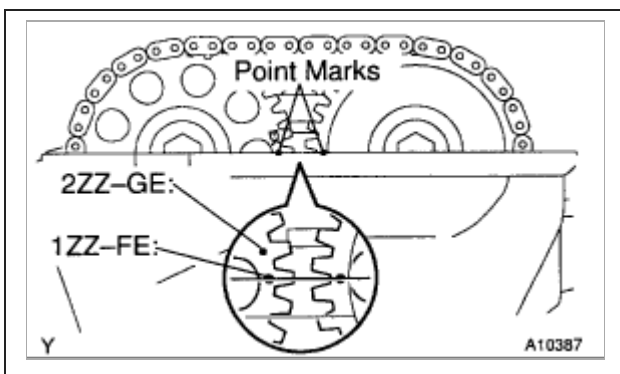

- b. Check that the point marks of the camshaft timing sprockets are in straight line on the timing chain cover surface as shown in the illustration. If not, turn the crankshaft **1 revolution (360°)** and align the marks.

3. INSPECT VALVE CLEARANCE

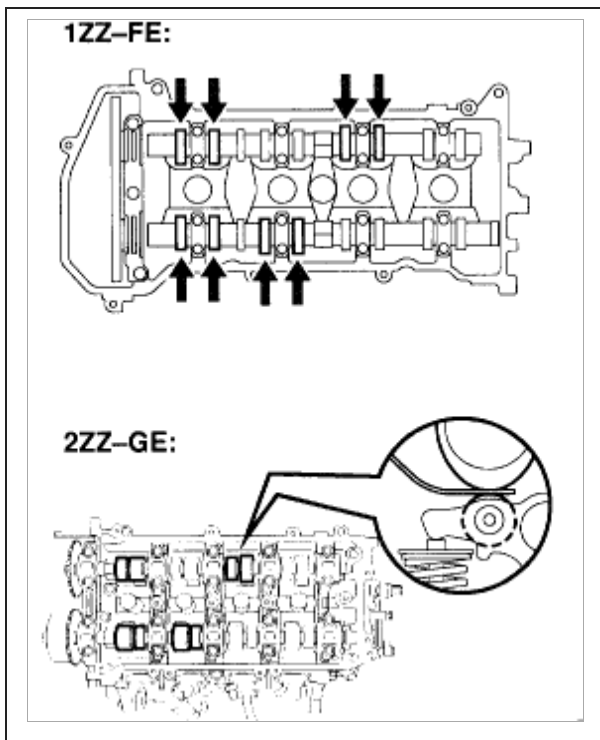

a. Check only the valves indicated.

- Using a feeler gauge, measure the clearance between the valve lifter and camshaft.
- Record the out-of-specification valve clearance measurements. They will be used later to determine the required replacement of adjusting shim. Valve clearance (Cold):

1ZZ-FE:

Intake: **0.15 - 0.25 mm (0.006 - 0.010 inch)**

Exhaust: **0.25 - 0.35 mm (0.010 - 0.014 inch)**

2ZZ-GE:

Intake: **0.08 - 0.18 mm (0.0031 - 0.0071 inch)**

Exhaust: **0.22 - 0.32 mm (0.0087 - 0.0126 inch)**

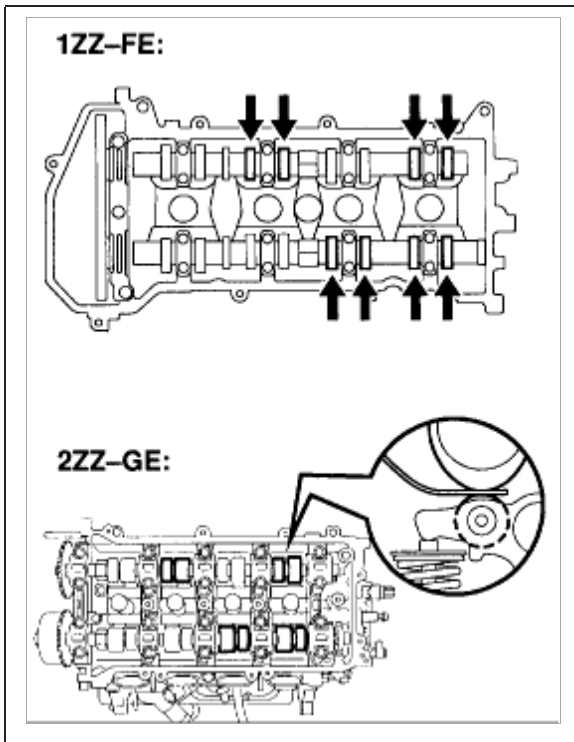

- b. Turn the crankshaft **1 revolution (360°)** and align the mark (See procedure in step 2).
- c. Check only the valves indicated as shown. Measure the valve clearance (See procedure in step (a)).

4. 1ZZ-FE: ADJUST VALVE CLEARANCE

- a. Set the No. 1 cylinder to the TDC/compression (See procedure in step 2).

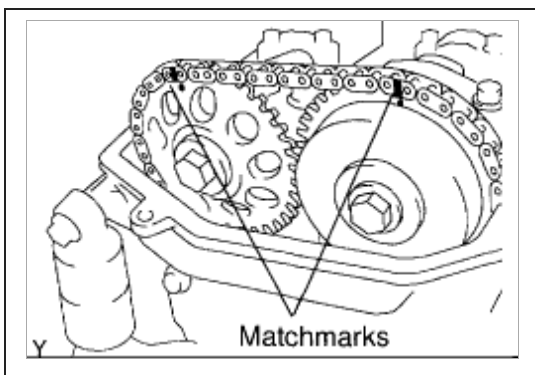

- b. Place matchmarks on the timing chain and camshaft timing sprockets.
- c. Remove the 2 bolts and chain tensioner.

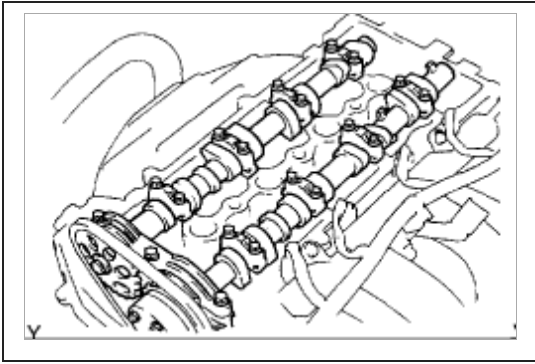

d. Remove the camshaft and timing sprocket assemblies.

- 1) 19 camshaft bearing cap bolts
- 2) 9 camshaft bearing caps (No. 1 & No. 3)
- 8) Exhaust camshaft and timing sprocket assembly
- 4) Intake camshaft and timing sprocket assembly

HINT: When holding the timing chain, disconnect the timing chain from the camshaft timing sprocket.

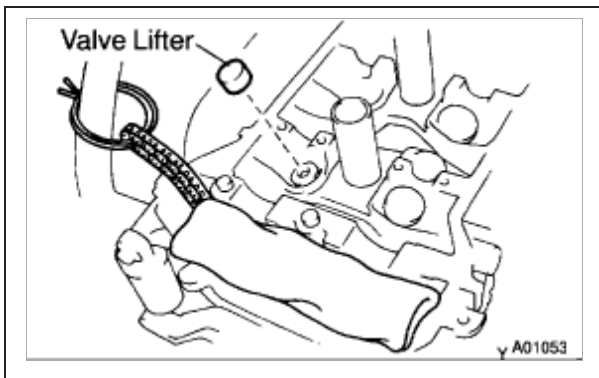

e. Tie the timing chain with a string as shown in the illustration.

NOTICE:

- Be careful not to drop anything inside the timing chain cover.
- Do not allow the chain to come into contact with water or dust.

f. Remove the valve lifters.

g. Determine the size of the replaced valve lifter according to these Formula or Charts:

2ZZ-GE: Valve Shim Selection Chart (Intake)

Installed shim thickness mm (in.)	Measure clearance mm (in.)	2.000 (0.7873)	2.005 (0.7894)	2.010 (0.7913)	2.015 (0.7932)	2.020 (0.7951)	2.025 (0.7970)	2.030 (0.7989)	2.035 (0.8008)	2.040 (0.8027)	2.045 (0.8046)	2.050 (0.8065)	2.055 (0.8084)	2.060 (0.8103)	2.065 (0.8122)	2.070 (0.8141)	2.075 (0.8160)	2.080 (0.8179)	2.085 (0.8198)	2.090 (0.8217)	2.095 (0.8236)	2.100 (0.8255)	2.105 (0.8274)	2.110 (0.8293)	2.115 (0.8312)	2.120 (0.8331)	2.125 (0.8350)	2.130 (0.8369)	2.135 (0.8388)	2.140 (0.8407)	2.145 (0.8426)	2.150 (0.8445)	2.155 (0.8464)	2.160 (0.8483)	2.165 (0.8502)	2.170 (0.8521)	2.175 (0.8540)	2.180 (0.8559)	2.185 (0.8578)	2.190 (0.8597)	2.195 (0.8616)	2.200 (0.8635)	2.205 (0.8654)	2.210 (0.8673)	2.215 (0.8692)	2.220 (0.8711)	2.225 (0.8730)	2.230 (0.8749)	2.235 (0.8768)	2.240 (0.8787)	2.245 (0.8806)	2.250 (0.8825)	2.255 (0.8844)	2.260 (0.8863)	2.265 (0.8882)	2.270 (0.8901)	2.275 (0.8920)	2.280 (0.8939)	2.285 (0.8958)	2.290 (0.8977)	2.295 (0.8996)	2.300 (0.9015)	2.305 (0.9034)	2.310 (0.9053)	2.315 (0.9072)	2.320 (0.9091)	2.325 (0.9110)	2.330 (0.9129)	2.335 (0.9148)	2.340 (0.9167)	2.345 (0.9186)	2.350 (0.9205)	2.355 (0.9224)	2.360 (0.9243)	2.365 (0.9262)	2.370 (0.9281)	2.375 (0.9300)	2.380 (0.9319)	2.385 (0.9338)	2.390 (0.9357)	2.395 (0.9376)	2.400 (0.9395)	2.405 (0.9414)	2.410 (0.9433)	2.415 (0.9452)	2.420 (0.9471)	2.425 (0.9490)	2.430 (0.9509)	2.435 (0.9528)	2.440 (0.9547)	2.445 (0.9566)	2.450 (0.9585)	2.455 (0.9604)	2.460 (0.9623)	2.465 (0.9642)	2.470 (0.9661)	2.475 (0.9680)	2.480 (0.9699)	2.485 (0.9718)	2.490 (0.9737)	2.495 (0.9756)	2.500 (0.9775)	2.505 (0.9794)	2.510 (0.9813)	2.515 (0.9832)	2.520 (0.9851)	2.525 (0.9870)	2.530 (0.9889)	2.535 (0.9908)	2.540 (0.9927)	2.545 (0.9946)	2.550 (0.9965)	2.555 (0.9984)	2.560 (1.0003)	2.565 (1.0022)	2.570 (1.0041)	2.575 (1.0060)	2.580 (1.0079)	2.585 (1.0098)	2.590 (1.0117)	2.595 (1.0136)	2.600 (1.0155)	2.605 (1.0174)	2.610 (1.0193)	2.615 (1.0212)	2.620 (1.0231)	2.625 (1.0250)	2.630 (1.0269)	2.635 (1.0288)	2.640 (1.0307)	2.645 (1.0326)	2.650 (1.0345)	2.655 (1.0364)	2.660 (1.0383)	2.665 (1.0402)	2.670 (1.0421)	2.675 (1.0440)	2.680 (1.0459)	2.685 (1.0478)	2.690 (1.0497)	2.695 (1.0516)	2.700 (1.0535)	2.705 (1.0554)	2.710 (1.0573)	2.715 (1.0592)	2.720 (1.0611)	2.725 (1.0630)	2.730 (1.0649)	2.735 (1.0668)	2.740 (1.0687)	2.745 (1.0706)	2.750 (1.0725)	2.755 (1.0744)	2.760 (1.0763)	2.765 (1.0782)	2.770 (1.0801)	2.775 (1.0820)	2.780 (1.0839)	2.785 (1.0858)	2.790 (1.0877)	2.795 (1.0896)	2.800 (1.0915)	2.805 (1.0934)	2.810 (1.0953)	2.815 (1.0972)	2.820 (1.0991)	2.825 (1.1010)	2.830 (1.1029)	2.835 (1.1048)	2.840 (1.1067)	2.845 (1.1086)	2.850 (1.1105)	2.855 (1.1124)	2.860 (1.1143)	2.865 (1.1162)	2.870 (1.1181)	2.875 (1.1200)	2.880 (1.1219)	2.885 (1.1238)	2.890 (1.1257)	2.895 (1.1276)	2.900 (1.1295)	2.905 (1.1314)	2.910 (1.1333)	2.915 (1.1352)	2.920 (1.1371)	2.925 (1.1390)	2.930 (1.1409)	2.935 (1.1428)	2.940 (1.1447)	2.945 (1.1466)	2.950 (1.1485)	2.955 (1.1504)	2.960 (1.1523)	2.965 (1.1542)	2.970 (1.1561)	2.975 (1.1580)	2.980 (1.1599)	2.985 (1.1618)	2.990 (1.1637)	2.995 (1.1656)	3.000 (1.1675)
--------------------------------------	-------------------------------	----------------	----------------	----------------	----------------	----------------	----------------	----------------	----------------	----------------	----------------	----------------	----------------	----------------	----------------	----------------	----------------	----------------	----------------	----------------	----------------	----------------	----------------	----------------	----------------	----------------	----------------	----------------	----------------	----------------	----------------	----------------	----------------	----------------	----------------	----------------	----------------	----------------	----------------	----------------	----------------	----------------	----------------	----------------	----------------	----------------	----------------	----------------	----------------	----------------	----------------	----------------	----------------	----------------	----------------	----------------	----------------	----------------	----------------	----------------	----------------	----------------	----------------	----------------	----------------	----------------	----------------	----------------	----------------	----------------	----------------	----------------	----------------	----------------	----------------	----------------	----------------	----------------	----------------	----------------	----------------	----------------	----------------	----------------	----------------	----------------	----------------	----------------	----------------	----------------	----------------	----------------	----------------	----------------	----------------	----------------	----------------	----------------	----------------	----------------	----------------	----------------	----------------	----------------	----------------	----------------	----------------	----------------	----------------	----------------	----------------	----------------	----------------	----------------	----------------	----------------	----------------	----------------	----------------	----------------	----------------	----------------	----------------	----------------	----------------	----------------	----------------	----------------	----------------	----------------	----------------	----------------	----------------	----------------	----------------	----------------	----------------	----------------	----------------	----------------	----------------	----------------	----------------	----------------	----------------	----------------	----------------	----------------	----------------	----------------	----------------	----------------	----------------	----------------	----------------	----------------	----------------	----------------	----------------	----------------	----------------	----------------	----------------	----------------	----------------	----------------	----------------	----------------	----------------	----------------	----------------	----------------	----------------	----------------	----------------	----------------	----------------	----------------	----------------	----------------	----------------	----------------	----------------	----------------	----------------	----------------	----------------	----------------	----------------	----------------	----------------	----------------	----------------	----------------	----------------	----------------	----------------	----------------	----------------	----------------	----------------	----------------

Intake valve clearance (Cold):
0.10 – 0.16 mm (0.0039 – 0.0063 in.)
EXAMPLE: The 2.200 mm (0.0826 in.) shim is installed, and the measured clearance is 0.400 mm (0.0157 in.).
 Replace the 2.600 mm (0.1024 in.) shim with a new No. 60 shim.

New Shim thickness mm (in.)

Shim No.	Thickness	Shim No.	Thickness	Shim No.	Thickness
50	2.000 (0.787)	58	2.280 (0.0898)	66	2.560 (0.1008)
52	2.020 (0.0795)	60	2.300 (0.0905)	68	2.580 (0.1016)
54	2.040 (0.0803)	62	2.320 (0.0913)	70	2.600 (0.1024)
56	2.060 (0.0811)	64	2.340 (0.0921)	72	2.620 (0.1031)
58	2.080 (0.0819)	66	2.360 (0.0929)	74	2.640 (0.1039)
60	2.100 (0.0827)	68	2.380 (0.0937)	76	2.660 (0.1047)
62	2.120 (0.0835)	70	2.400 (0.0945)	78	2.680 (0.1055)
64	2.140 (0.0843)	72	2.420 (0.0953)	80	2.700 (0.1063)
66	2.160 (0.0851)	74	2.440 (0.0961)	82	2.720 (0.1071)
68	2.180 (0.0858)	76	2.460 (0.0969)	84	2.740 (0.1079)
70	2.200 (0.0866)	78	2.480 (0.0976)	86	2.760 (0.1087)
72	2.220 (0.0874)	80	2.500 (0.0984)	88	2.780 (0.1094)
74	2.240 (0.0882)	82	2.520 (0.0992)	90	2.800 (0.1102)
76	2.260 (0.0890)	84	2.540 (0.1000)		

2ZZ-GE

Exhaust: N = T + (A - 0.30 mm (0.012 inch))

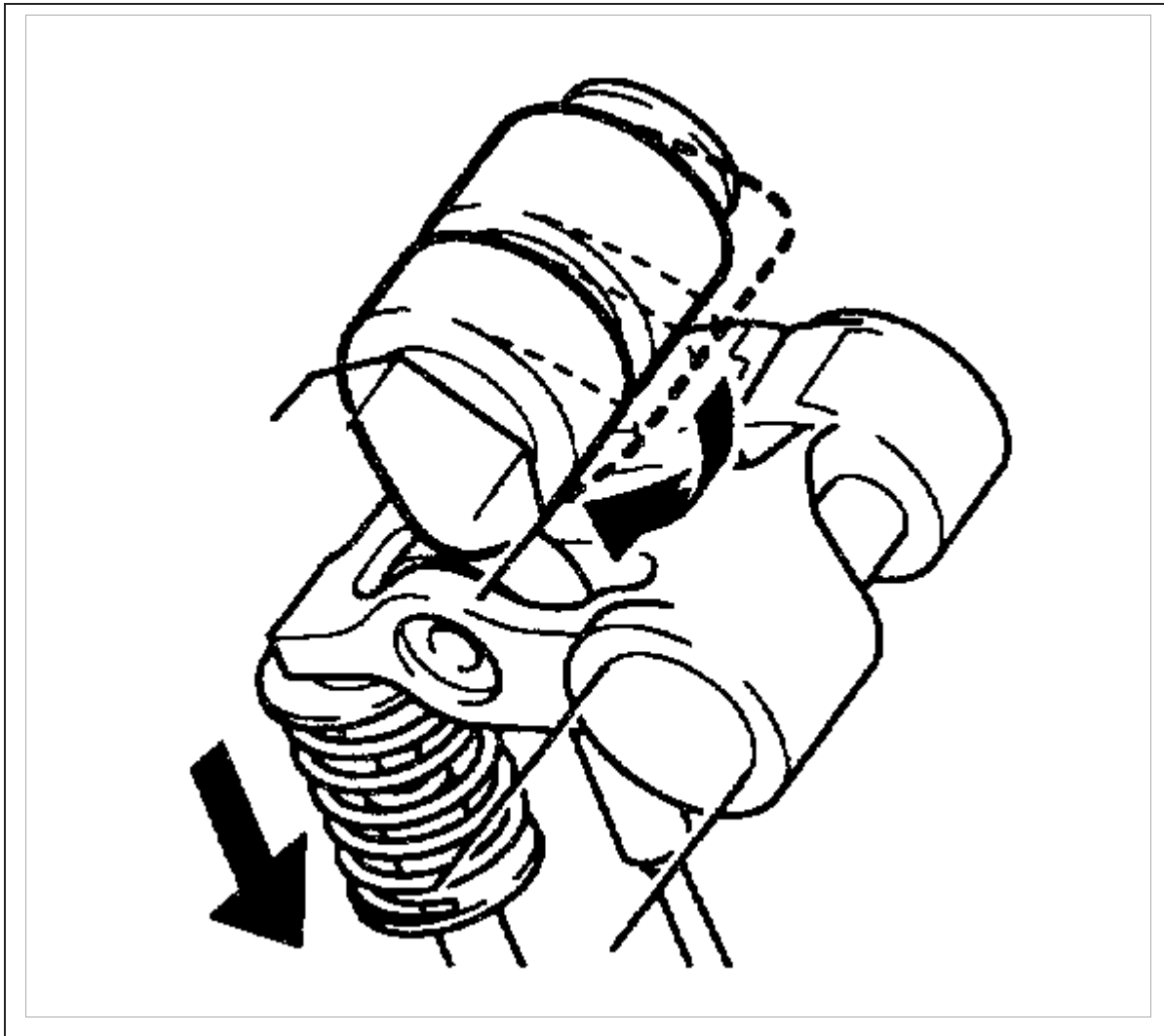

1) Turn the crankshaft so that the related rocker arm, where the valve clearance is adjusted, is fully pushed down.

NOTICE: Remove the [spark plug](#) and take off the compression.

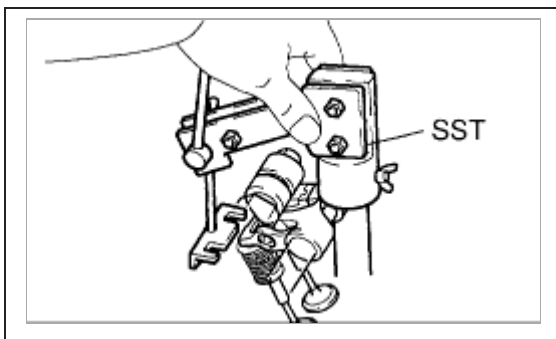

2) Insert SST into the plug tube.

SST 09248-77010 (09248-07010)

NOTICE:

- SST cannot be inserted unless the set screw is loosened.
- Make sure that the camshaft is in the same condition as step (1).

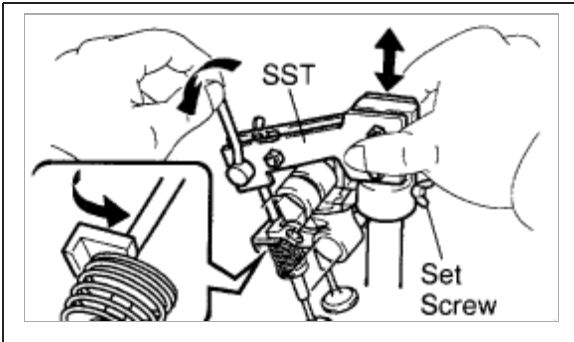

3) Operate the lever so that SST's seat surface comes to contact with the valve retainer and lock them with the set screw.

NOTICE:

- Clearance between the valve retainer and SST's seat surface is not allowed.
 - Care should be taken not to make clearance when inserting SST, since a presence of clearance may unlock the keeper.
- 4) Lock the set screw on the plug tube side of SST.

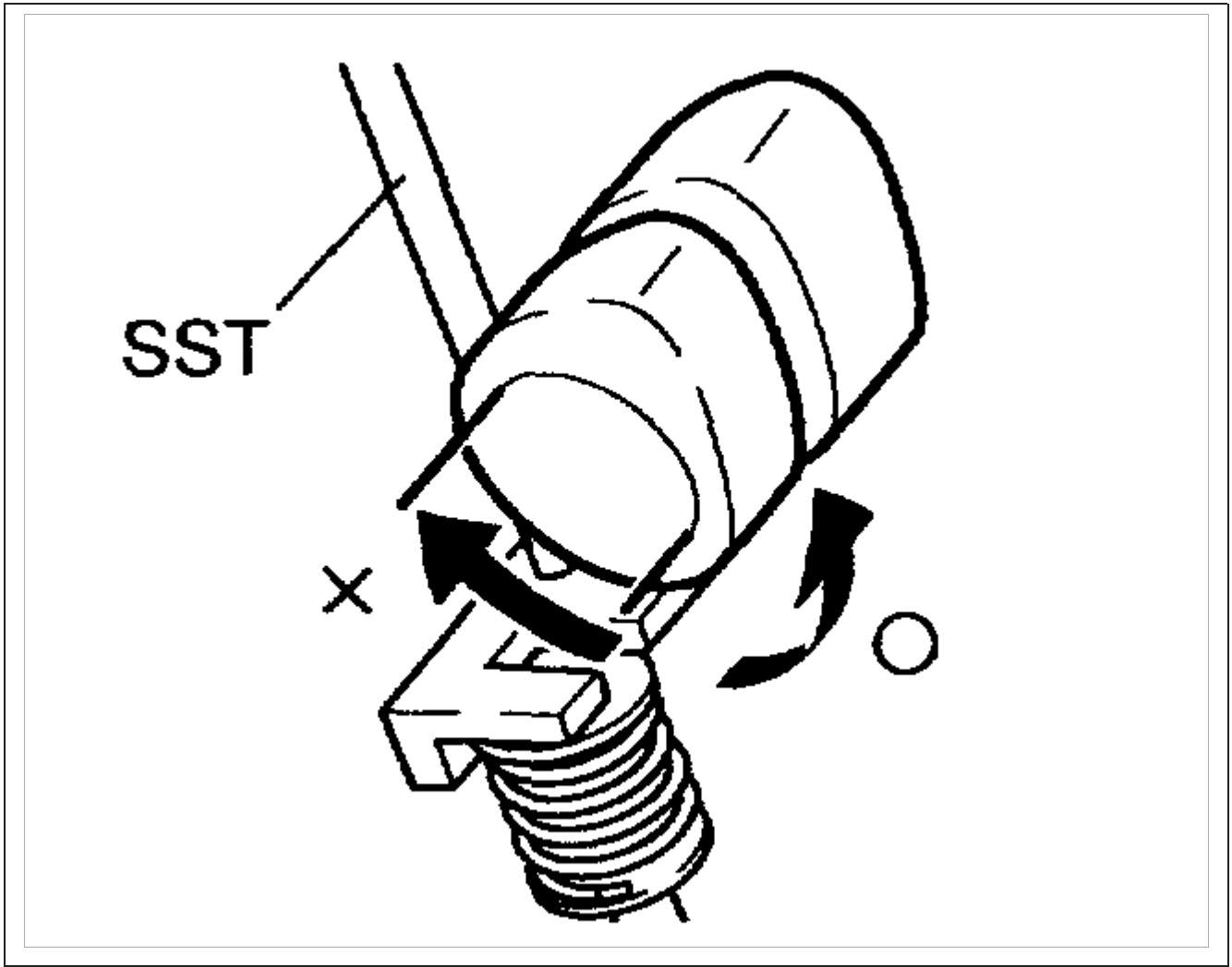

5) Rotate the crankshaft so that the camshaft is positioned as shown in the illustration.

NOTICE:

- Pay attention to the direction of the rotation to prevent the nose of the camshaft from interfering with the SST's shaft.
- Do not rotate the crankshaft excessively.

b. Remove the adjusting shim.

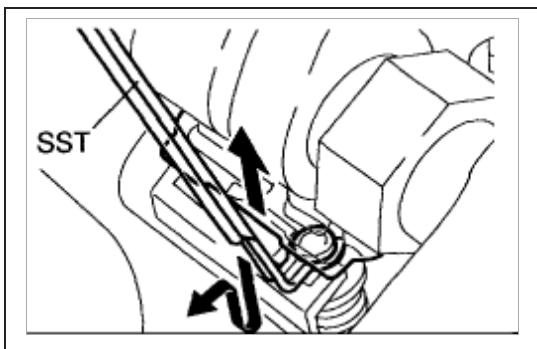

1) Lift the rocker arm to make a room and remove the adjusting shim using SST.

SST 09248-77010 (09248-07020)

NOTICE: Do not remove SST in the condition that the adjusting shim is removed.

HINT:

- Setting SST from the right makes the removal easy.
- If there is not enough room, reset SST.

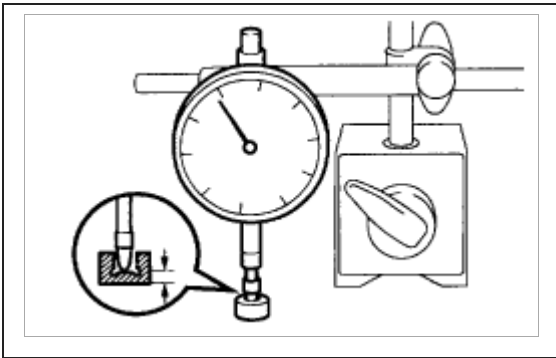

2) Determine the size of the replaced shim according to these Formula or Charts:

- Using dial indicator, measure the thickness of the removed shim.
- Calculate the thickness of a new shim so the valve clearance comes within the specified value. T Thickness of used shim

A Measured valve clearance

N Thickness of new shim

Intake: $N = T + (A - 0.13 \text{ mm (0.0051 inch)}) \times 1.5$

Exhaust: $N = T + (A - 0.27 \text{ mm (0.0106 inch)}) \times 1.5$

- Select a new shim with a thickness as close as possible to the calculated values.

HINT: Shim are available in 41 size in increments of 0.020 mm (0.0008 inch), from 2.000 mm (0.0787 inch) to 2.800 mm (0.1102 inch).

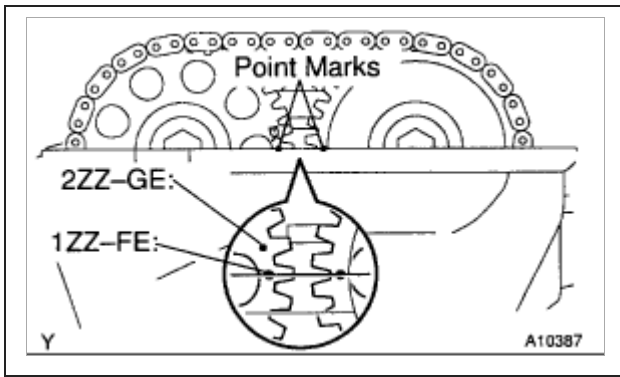

6. 1ZZ-FE: REINSTALL CAMSHAFT

- a. Reinstall the valve lifters.
- b. Align the crankshaft pulley groove with the timing mark "0" of the timing chain cover.
- c. Hold the timing chain, and place the intake camshaft and timing sprocket assembly.
- d. Align the matchmarks on the timing chain and camshaft timing sprocket.
- e. Reinstall the camshaft and timing sprocket assemblies.
- f. Check that the point marks of the camshaft timing sprockets are in straight line on the timing chain cover surface as shown in the illustration.
- g. Check that the matchmarks are on the timing chain and camshaft timing sprockets.
- h. Install the chain tensioner.
- i. Recheck the valve clearance (See procedure in step 3).
- j. Check the valve timing.

7. 2ZZ-GE: REINSTALL ADJUSTING SHIM

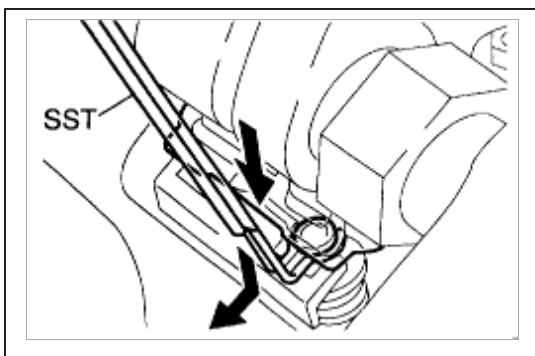

- a. Lift the rocker arm to make a room and use SST, install the adjusting shim.

HINT:

- Setting SST from the right makes the removal easy.
- To remove SST from the adjusting shim, it is advisable to push down the rocker arm.

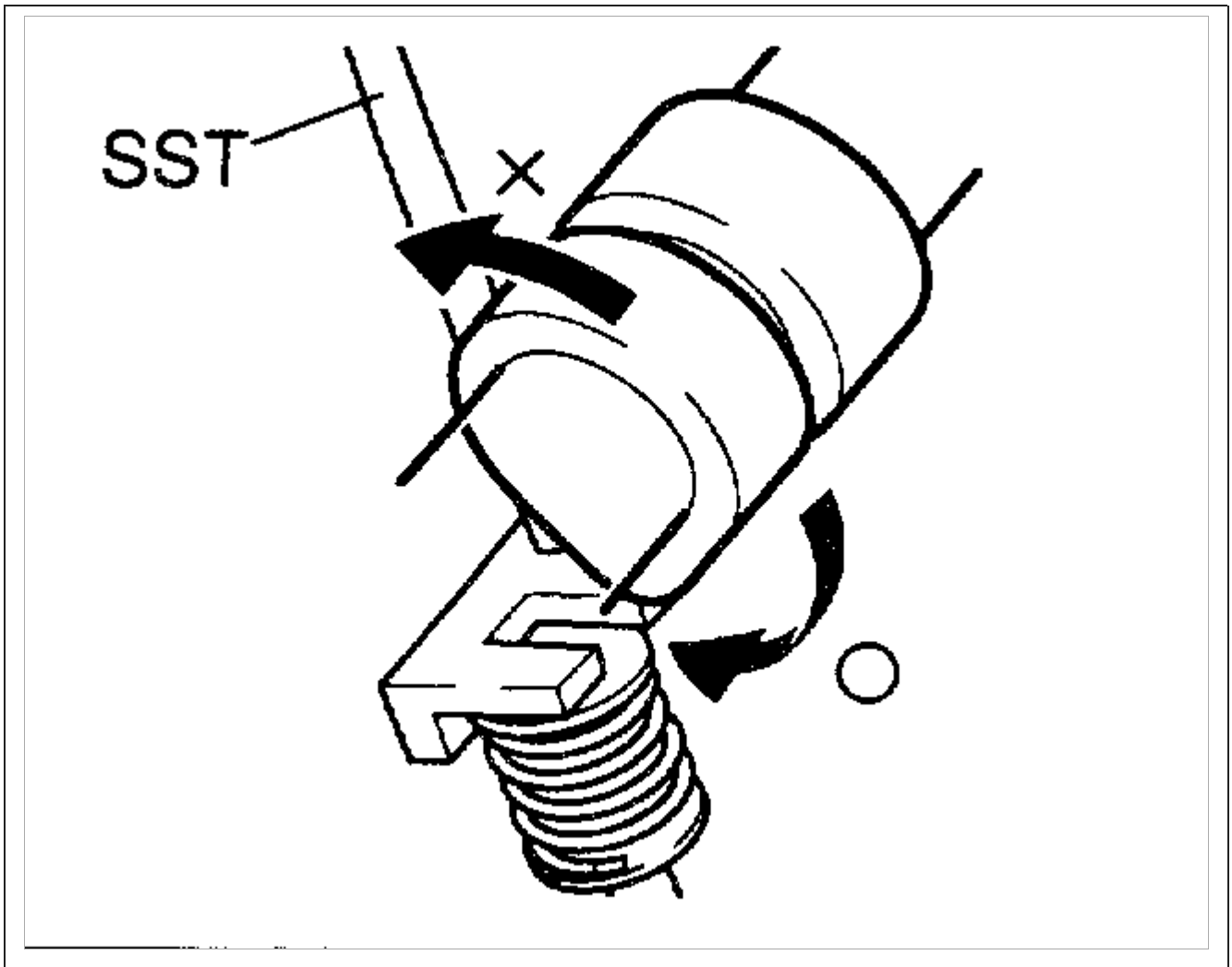

b. Turn the crankshaft so that the related rocker arm, where the valve clearance is adjusted, is fully pushed down.

NOTICE:

- Pay attention to the direction of the rotation to prevent the nose of the camshaft from interfering with the SST's shaft.
- Do not rotate the crankshaft excessively.

c. After loosening the 2 set screws of SST, remove SST it self. SST 09248-77010 (09248-07010)

8. REINSTALL CYLINDER HEAD COVER

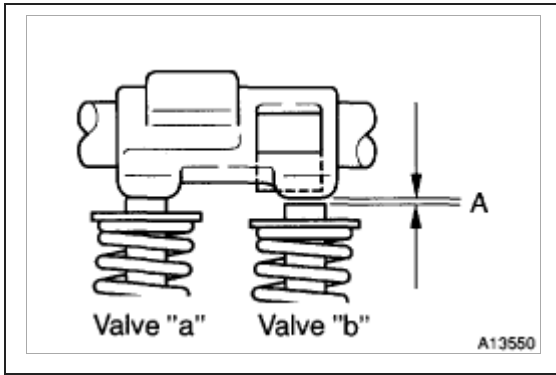

9. IF VALVE OR ROCKER ARM IS REPLACED, REPLACE SHIM AS FOLLOWS

- a. Install a standard shim of **2.400 mm (0.0945 inch)** thickness at low temperature and install the rocker arm.
- b. While pressing the rocker arm, measure the clearance "A" of valve "b" in the condition that a clearance of the other valve is **0 mm (0 inch)** .
- c. To adjust the valve highs, replace a shim of valve "b" with a shim that has thickness of $\text{tot1} = \mathbf{A + 2.400}$
- d. After adjusting the valve highs, adjust the clearance as described from step 3.