

2004R SHIFT RECALIBRATION KIT #24RSRK-B/SS

This easy to install kit includes all the necessary parts to recalibrate the hydraulic circuitry of the GM2004R transmission for high performance street and drag strip usage. The main focus of this kit is to reduce clutch and band slippage common with the factory hydraulic calibration. All the components in this kit work together to achieve the desired results. Mixing parts and tech from other kits will produce undesirable results and make it difficult for us to assist you if there are problems or issues that the kit has not corrected, or that result after installation. New .555" TV boost valve, revised pressure regulator valve and high rate pressure regulator spring significantly raise transmission mainline pressure to increase clutch and band apply pressures and capacity. This reduces friction element failure and excessive heat buildup during ratio changes. A newly designed separator plate is properly orificed to increase the flow of oil to the friction elements, and eliminates unnecessary circuits. Re-engineered springs for the accumulator valve, line bias, and 1-2 accumulator furnish a throttle sensitive accumulator and pressure rise system that meets the demands of high output engines. This kit allows the shifts to get shorter and firmer as the throttle is opened, resulting in clean, positive gear changes at small throttle angles, and short firm shifts at larger throttle angles. Most kits do not have this feature engineered into them resulting in brutal part throttle shifts that beat and break internal components as well as generate many new drivability complaints. Several thousand of these kits are in use and this kit is recognized as the best of its kind. Shift point rpm and road speed are a function of the tv cable adjustment and geometry, valve body, governor and axle ratio in use. This kit will not change shift point rpm or road speed. If higher or lower shift points are needed, contact us for assistance.

****CONTACT INFORMATION****

WWW.CKPERFORMANCE.COM

KIT CONTENTS FOR PART # 24RSRK-B/SS
2004R SHIFT RECALIBRATION KIT

1 PRESSURE REGULATOR VALVE SPRING
1 .500" TV BOOST VALVE AND SLEEVE
1 .300" REVERSE BOOST VALVE AND SLEEVE
1-2 ACUMULATOR SPRING (LARGE PLAIN)
4 .250" CUP PLUGS
1 ACCUMULATOR VALVE SPRING (LONG PLAIN)
1 LINE BIAS VALVE SPRING (SHORT TIGHT WOUND)
1 SEPERATOR PLATE
1 CASE TO SEPERATOR PLATE GASKET
1 SEPERATOR PLATE TO VALVE BODY GASKET
1 ACCUMULATOR HOUSING GASKET
1 PAN GASKET
1 BILLET SERVO ASSEMBLY

INSTALLATION INSTRUCTIONS FOR PART #24RSRK-B/SS
2004R SHIFT RECALIBRATION KIT

Begin by removing the transmission oil pan. If the transmission is in the vehicle when installing this kit, be sure to allow adequate time for the vehicle to cool before removing the oil pan. Remember that the pan is full of oil when removing it. Be careful so that you do not spill oil in your work area. Remove the transmission oil filter. Verify the presence of the oil filter o-ring seal or multi lip seal on the oil filter neck. If the o-ring seal is not present, remove it from the pump bore and reinstall it. If the filter is equipt with a multi lip seal, it is ok if it remains in the pump bore. Remove and discard the transmission oil pan gasket. Thoroughly clean the transmission oil pan and magnet. Clean the gasket mounting surfaces on oil pan and transmission case.

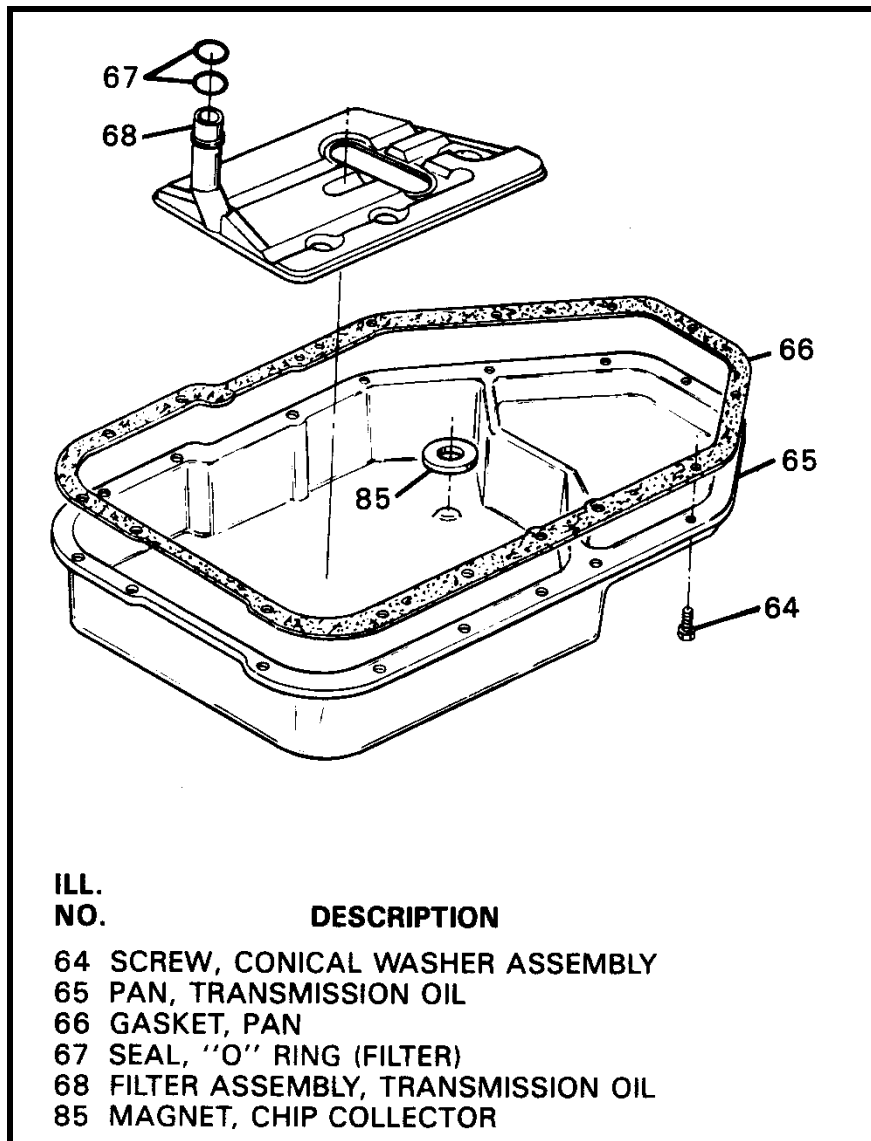

OIL PAN AND FILTER

Remove the two bolts (54) that fasten the solenoid assembly (53) to the case. Unplug the wiring harness from the electrical connector (39). Disconnect any of the pressure or temperature switches from the wiring harness and unhook the wiring harness from any solenoid wire and filter retainer clips (79, 82) that are installed on the valve body.

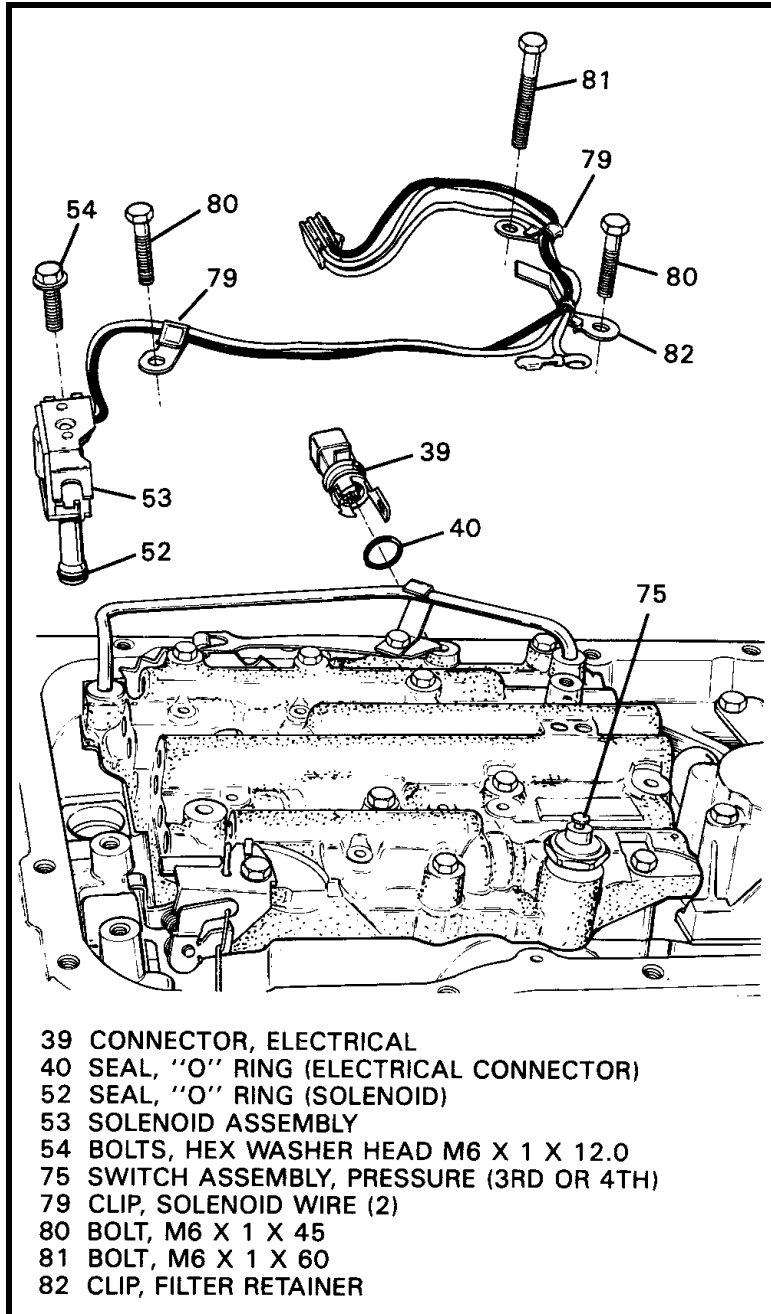

INTERNAL WIRING HARNESS

There are a few different types of internal wiring harnesses. The most common types are shown here.

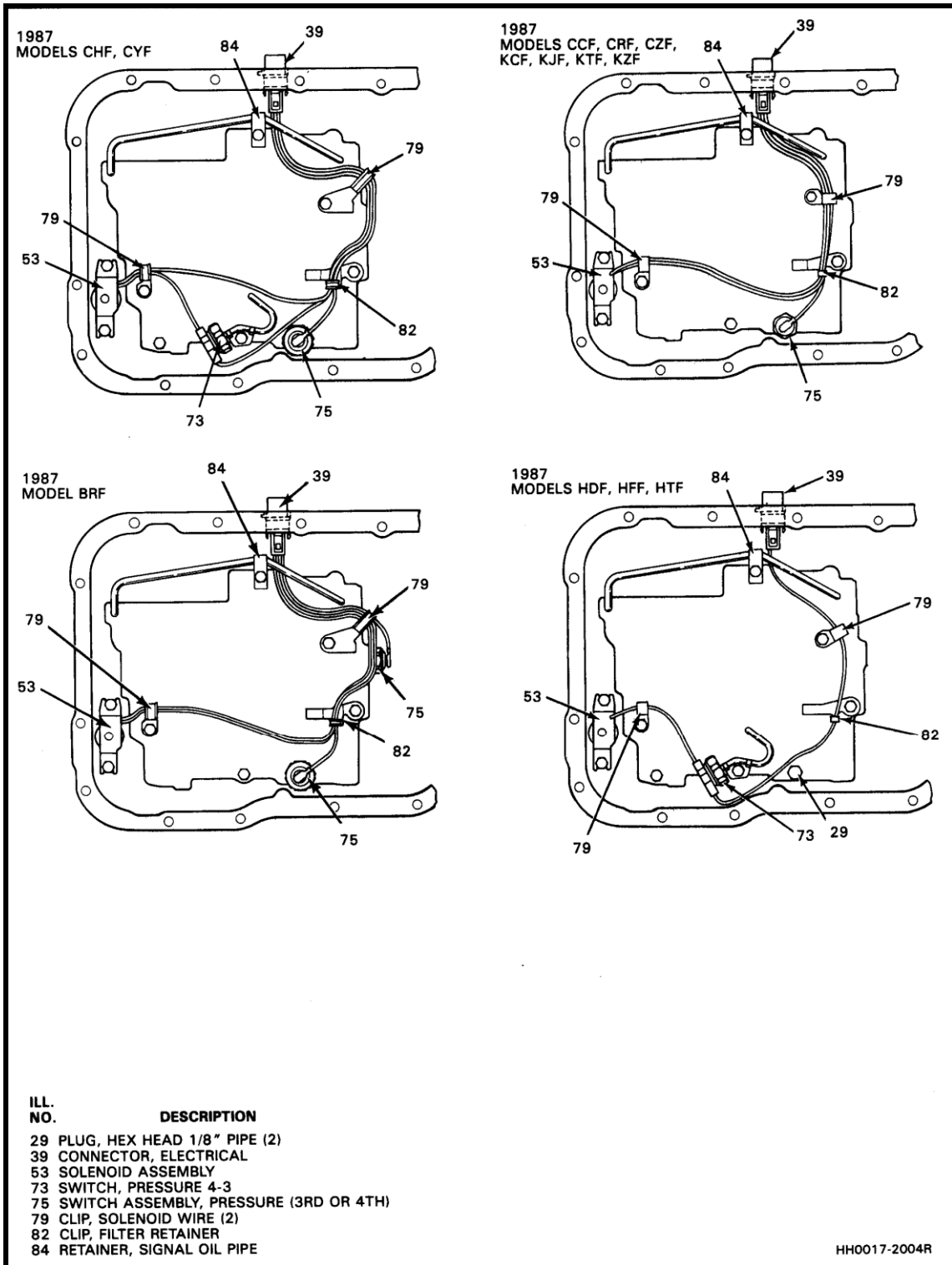

COMMON INTERNAL WIRING HARNESS'S

Remove and discard both the signal oil pipe retainer (84) and signal oil pipe (83). Remove the throttle lever and bracket assembly and related components (69, 70, 71 and 72). Remove the remaining bolts that fasten the valve body assembly to the transmission case and remove the valve body. If the transmission is in the car be sure to support the valve body when removing the bolts. Remember there are checkballs in the valve body, do not lose them. Remove the 1-2 accumulator housing (62) and its related components. Discard the accumulator housing gasket (58) and the 1-2 accumulator spring (59). Remove and discard the separator plate and gaskets (56, 86 and 87). Remember there are checkballs on top of the separator plate, do not lose them. Remove and discard the 3-4 accumulator piston (49) and the 3-4 accumulator spring (51). Note that some models have the spring on top of the piston and others have it at the bottom. Remove the 3-4 accumulator piston pin (76) from its bore in the transmission case.

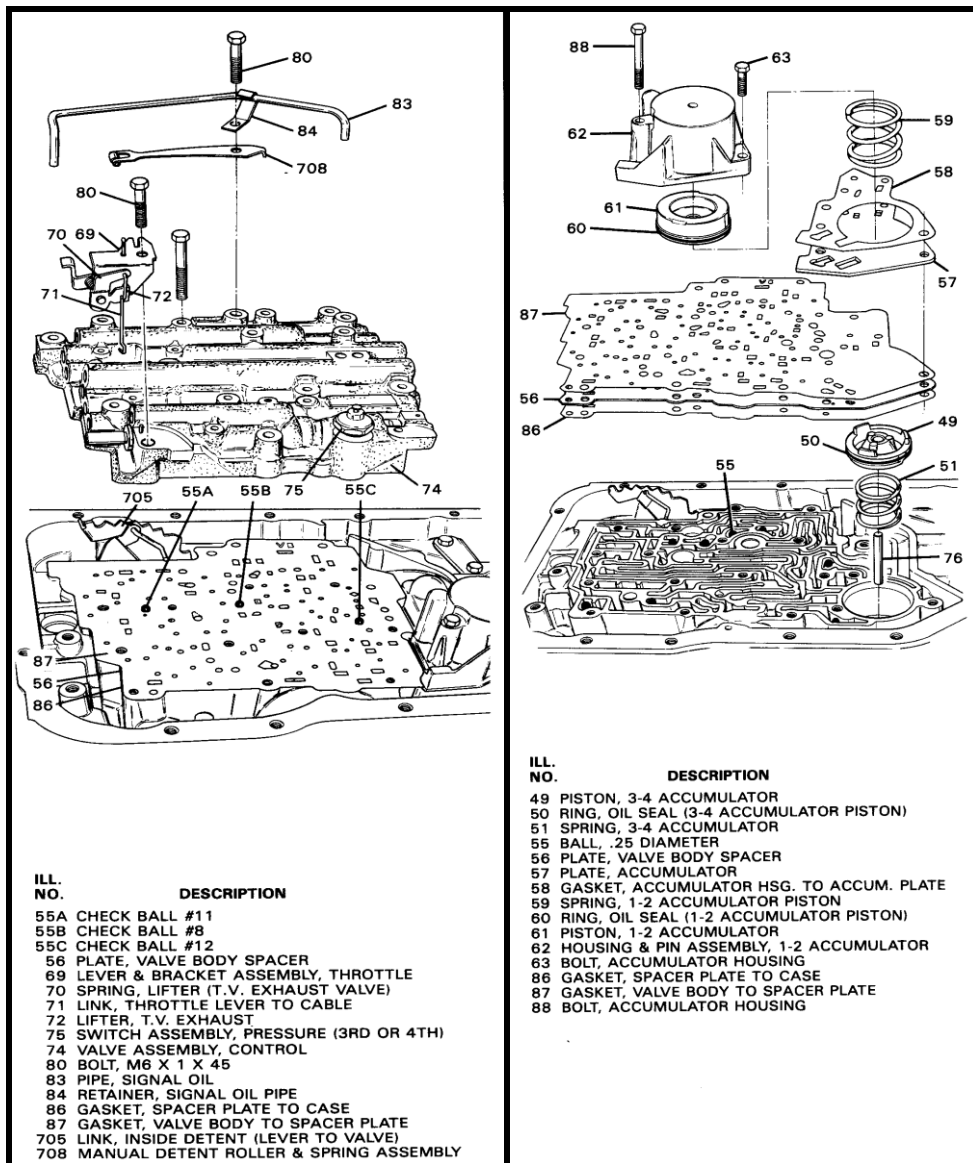

VALVE BODY AND RELATED COMONENTS

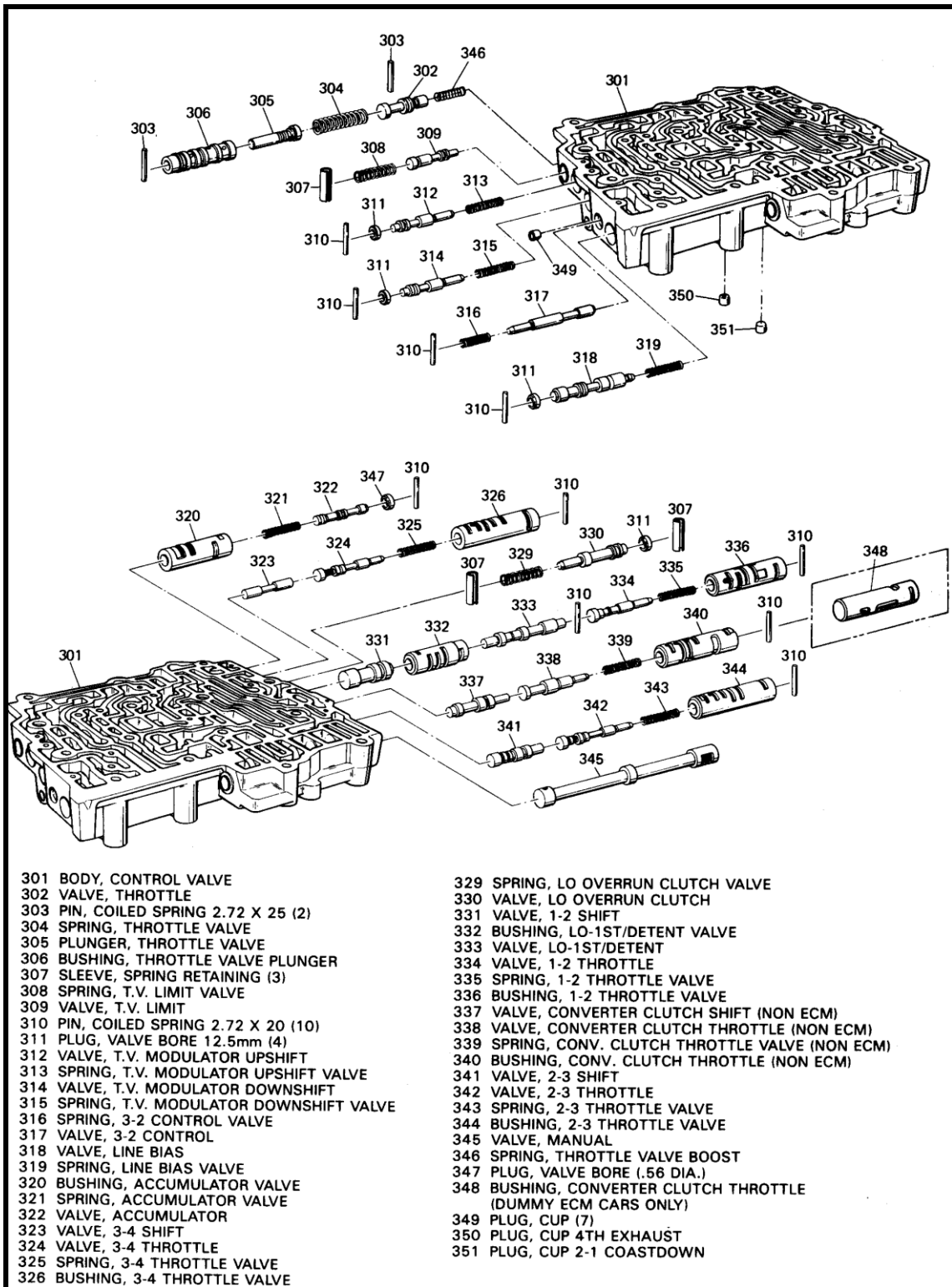

VALVE BODY EXPLODED VIEW

Locate the accumulator valvetrain and related components (310, 347, 322, 321 and 320) and remove them from the valve body as shown in the figure below. Replace the accumulator valve spring (321) with the one supplied in this kit and install the components back into the valve body exactly as shown in the figure. The replacement accumulator valve spring in this kit is approximately .265" in diameter and has an overall length of approximately 1.320".

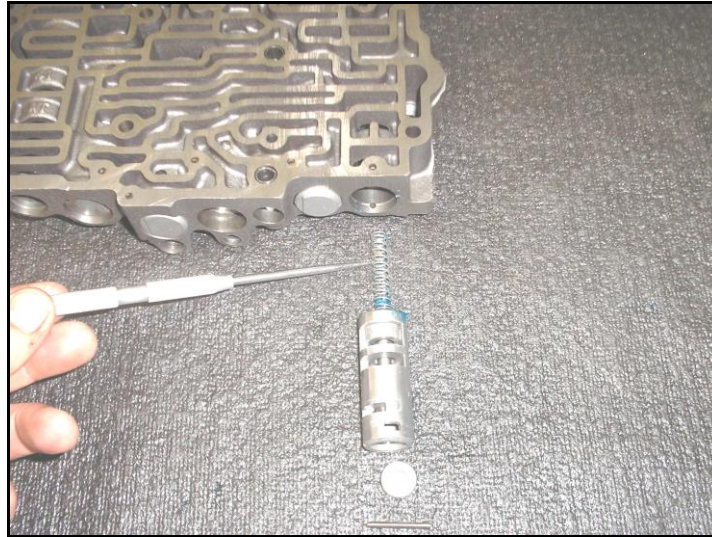

ACCUMULATOR VALVETRAIN

Locate the line bias valve and related components (310, 311, 318 and 319) and remove them from the valve body as shown in the figure below. Replace the line bias valve spring (319) with the one supplied in this kit and install the components back into the valve body exactly as shown in the figure. The replacement line bias valve spring in this kit is approximately .187" in diameter and has an overall length of approximately .925". This is a tightly wound spring. It may be necessary to gently tap the valve bore plug (311) to permit installation of the roll pin (310).



LINE BIAS VALVETRAIN

Locate the 3-2 control valvetrain and related components (310, 316 and 317) and remove them from the valve body as shown in the figure below. Discard the 3-2 control valve spring (316).

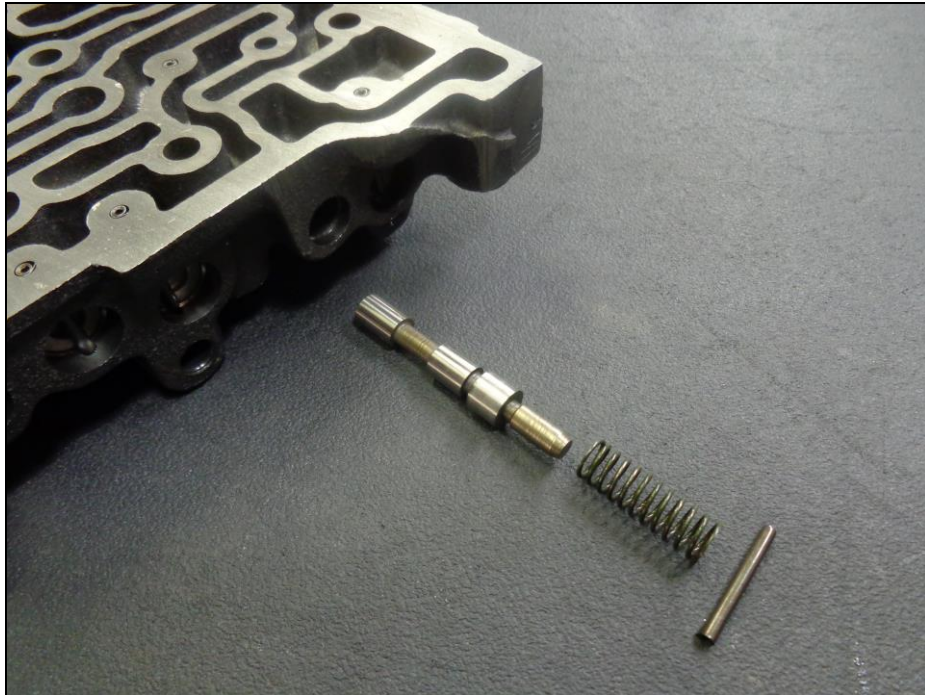

Install one .250" cup plug (cupped end toward the valve) onto the inboard end of the 3-2 control valve (retain with petroleum jelly) and install the valve into the bore exactly as shown in the figure below.

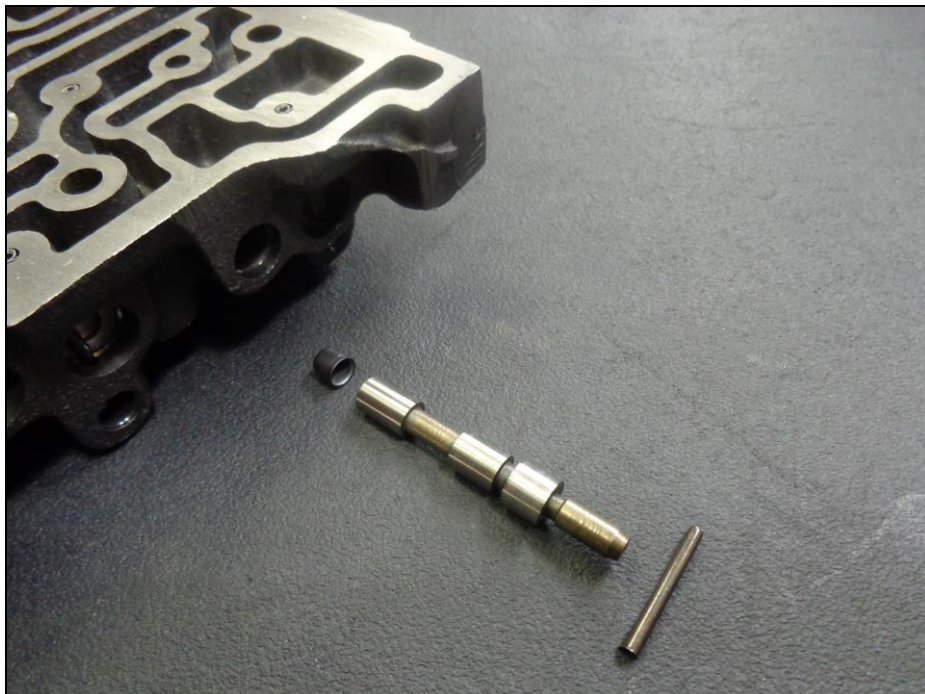

Install one .250” cup plug (cupped end up) into the valve body passage as shown in the figure below. The plug is meant to close off the rear signal oil pipe passage. The front signal oil pipe passage must be left open as a vent.

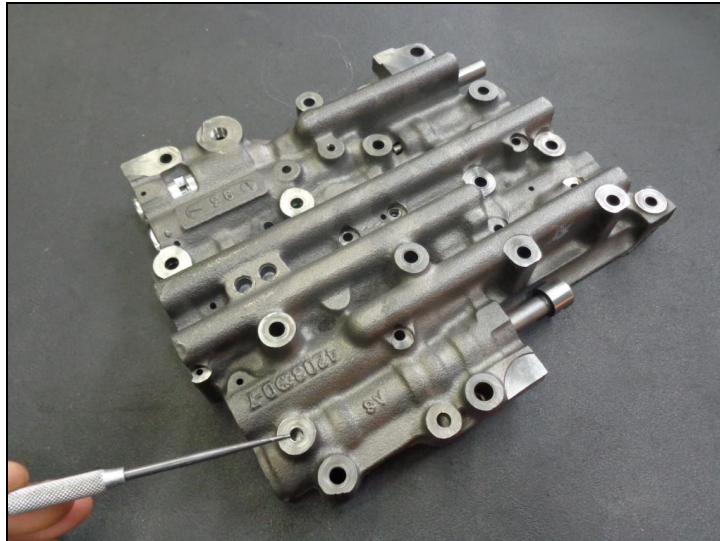

The 1-2 accumulator influences 1-2 upshift feel. To give tunability over the circuit there are two possible 1-2 accumulator combinations. The first is for all engines with up to 275 horsepower, with performance axle ratio (i.e. 3.23:1-3.73:1) and stall converters up to 2200 rpm. Install the supplied 1-2 accumulator spring (59) on top of the 1-2 accumulator piston as shown in the figure. Install it into the 1-2 accumulator housing (62) as shown in the figure used for disassembly. The second combination is for all applications above 275 horsepower. Omit the 1-2 accumulator piston (60) and spring (59). Using a small punch install one of the supplied .250” cup plugs flush into the 1-2 accumulator feed hole in the 1-2 accumulator housing (62). This is shown in the figure below. After installing the cup plug, be sure to deck the housing so that is completely flat.

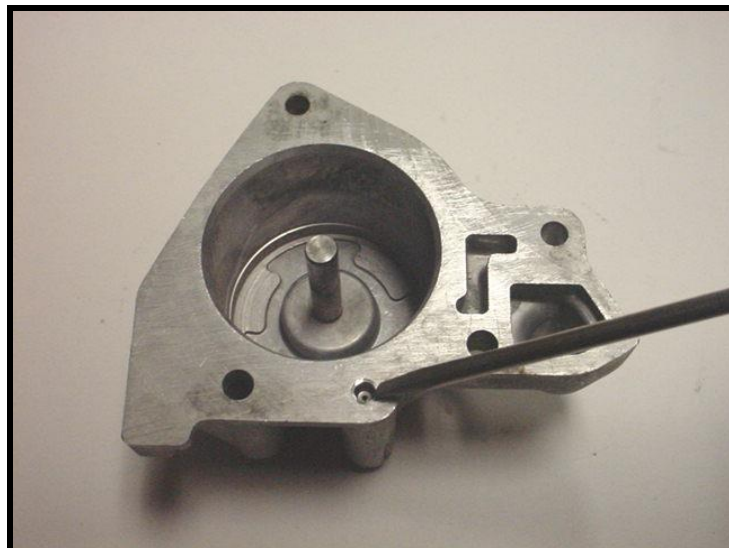

Discard the 3-4 accumulator pin, piston and spring. Using a small punch install one of the supplied .250" cup plugs flush into the 3-4 accumulator feed hole in the case, deleting the accumulator. This feed hole is pointed out in the figure below. The hole intersects with the 3-4 accumulator piston bore in the transmission case.

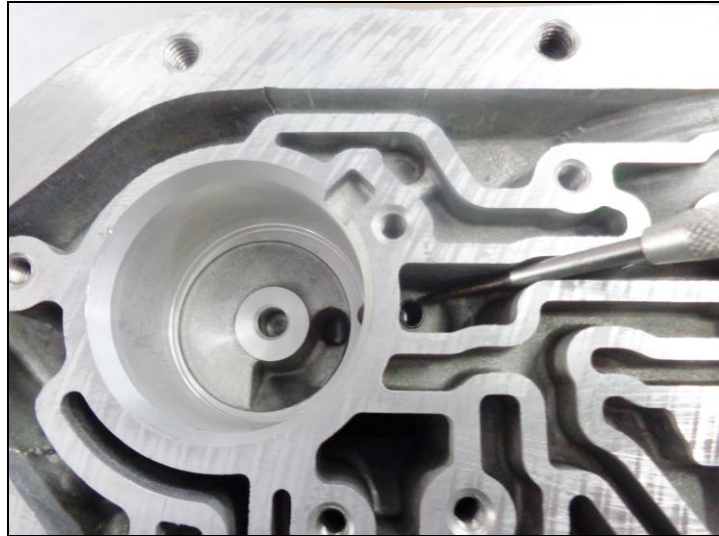

If this kit is being installed with the transmission out of the vehicle, install four .250" checkballs at the locations shown in the figure below. All the locations will resemble "bathtubs". Your transmission will have extra checkballs in the case. Only install the four shown in the figure.

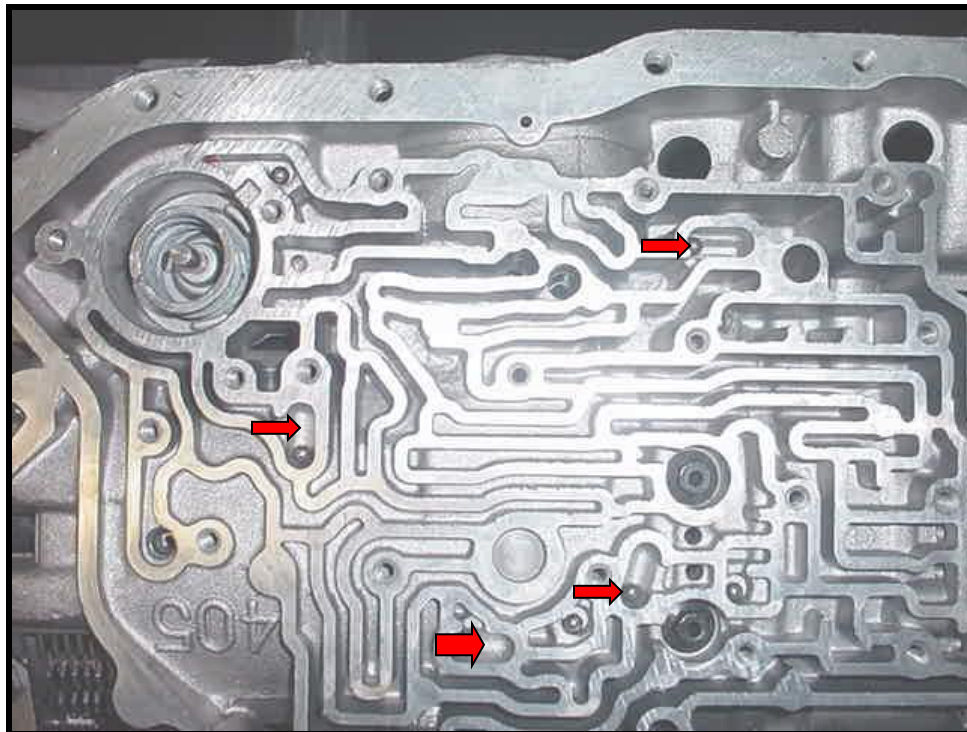

The size of the orifices at locations A, B1, B2, C, and D called out on the separator plate influence shift feel during the upshifts. The orifice immediately below the letter "A" is for the 1-2 upshift. The orifice immediately below the letter/number combinations "B1" and "B2" are for the 2-3 upshift. The orifice immediately below the letter "C" is for the 3-4 upshift. For engine combinations producing up to 250 horsepower drill orifices out "A" and "C" between .078" to .088", and "B1" and "B2" to between .084" to .094". For engine combinations producing up to 350 horsepower drill orifices out "A" and "C" between .084" to .094", and "B1" and "B2" to between .090" to .098". For engine combinations producing over 350 horsepower drill orifices out "A" and "C" to .110", and "B1" and "B2" to .125". Be sure to use the sizes recommended. Orifice "D" is for the 2-3 accumulator feed. For engine combinations producing up to 350 horsepower, drill it out to between .115" and .125". For engine combinations producing over 350 horsepower drill out to .140"

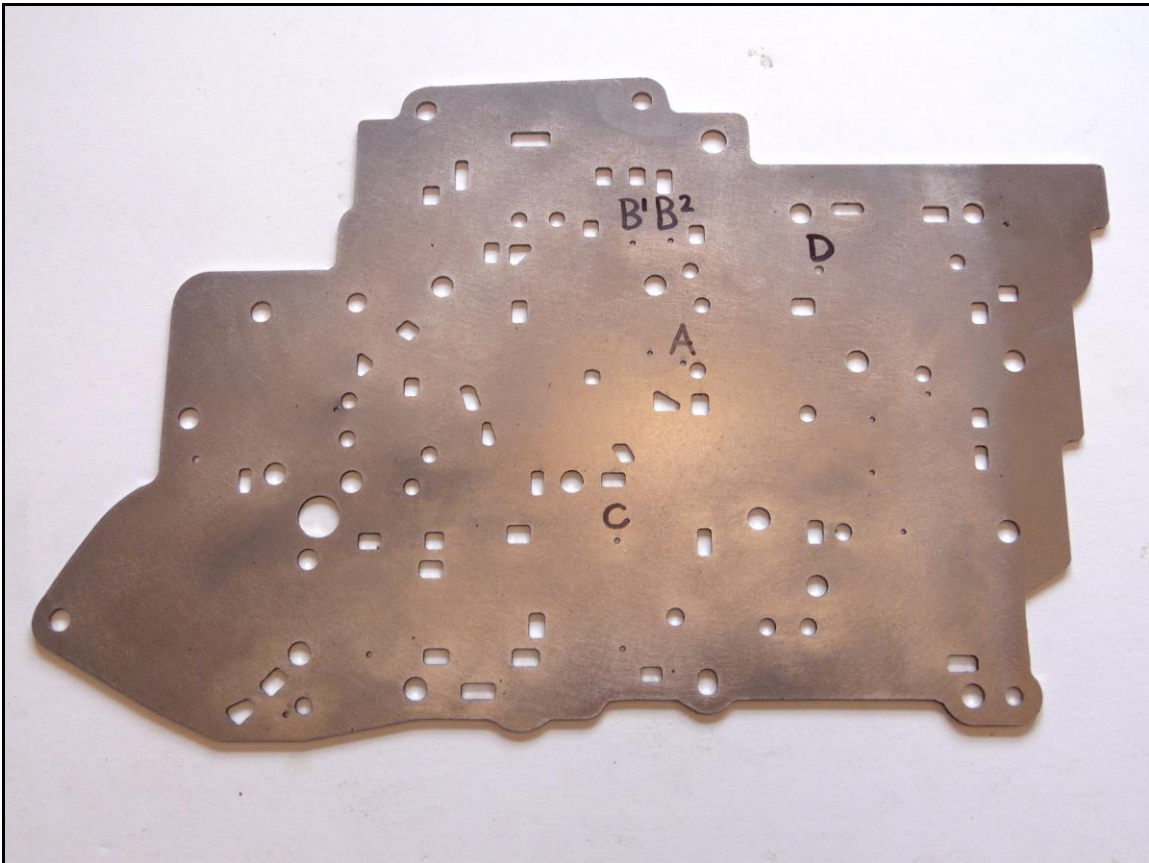

If this kit is being installed with the transmission in the vehicle, install four .250" checkballs at the locations shown in the photo below. Use a slight dab of petroleum jelly to retain the checkballs to the plate. Your transmission will have extra checkballs on the plate. Only install the four shown in the figure.

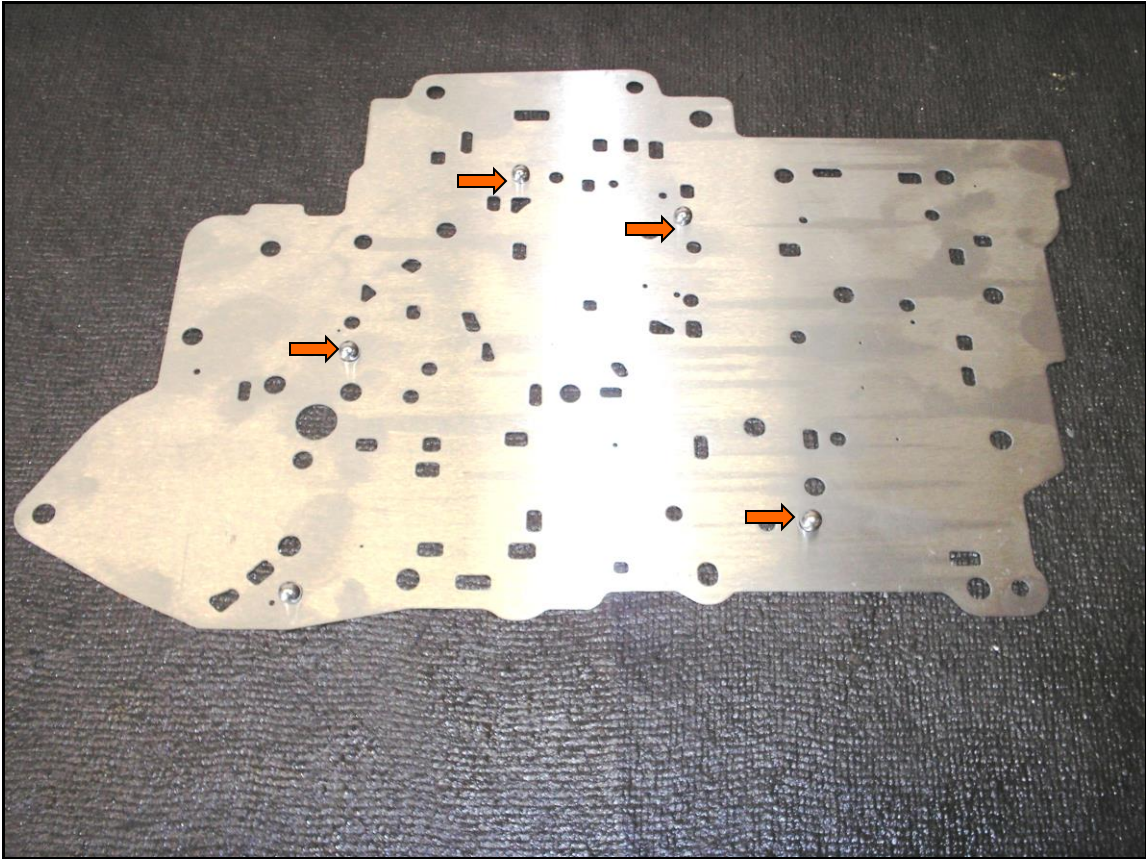

Reinstall the separator plate and gaskets (56, 86, 87), accumulator plate and gasket (57, 58), and the 1-2 accumulator housing (62) and its related components onto the transmission case. Finger tighten the accumulator housing bolts.

Install three .250" checkballs at the locations shown in Figure. If the vehicle has over 500 horsepower or a torque converter with over 3200 RPM stall speed, you may omit the center or middle checkball. This will give the firmest 1-2 upshift. **DO NOT OMIT** the checkball with low RPM stall converter or harsh 1-2 upshifts will result.

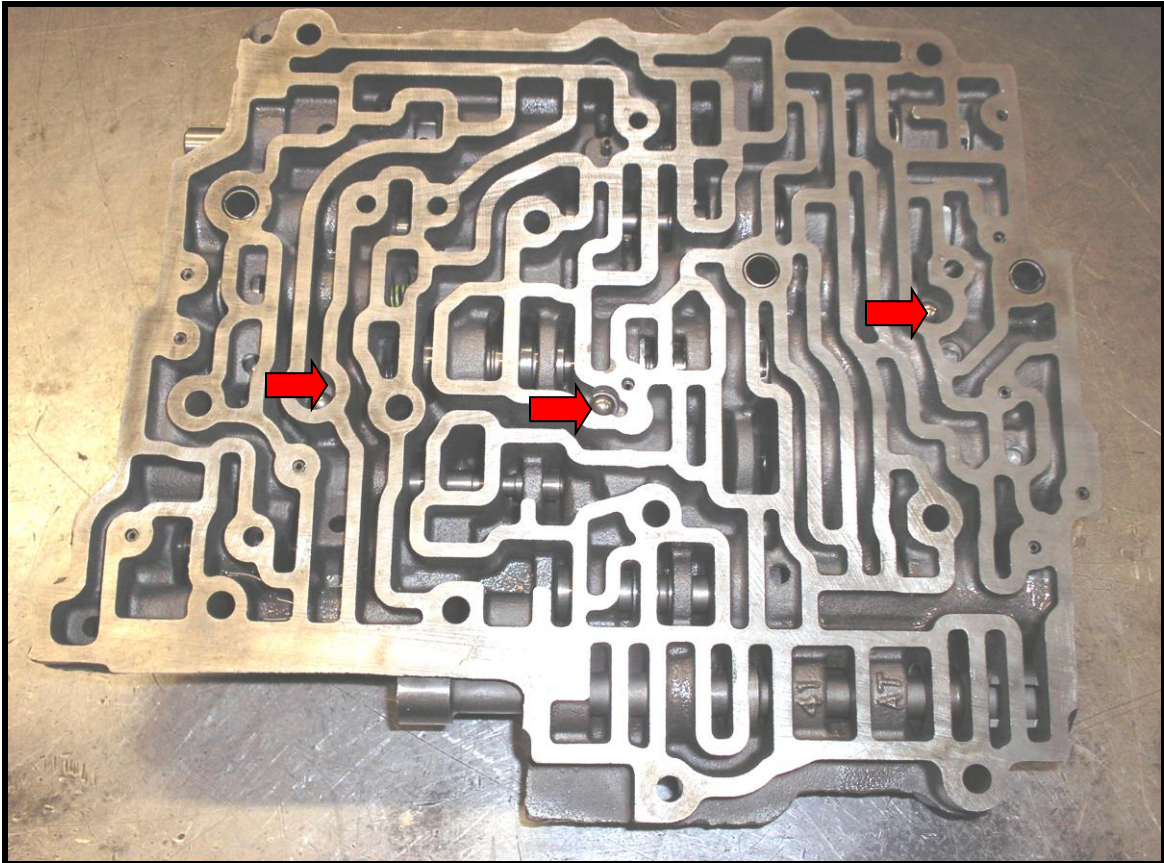

Install the valve body and related components to the transmission case. Finger tighten the bolts. Install the solenoid wiring harness assembly onto the valve body and plug it into the case connector. Install the solenoid into its bore and torque the retaining bolts (54) to 100 inch lbs. Reinstall the remaining valve body bolts and working your way from the inside out, torque the 15 valve body and accumulator housing bolts to 125 inch pounds. Before continuing, check for proper operation of the manual linkage by moving it back and forth. It should click 6 times in each direction and lock the drive shaft when shifted into park.

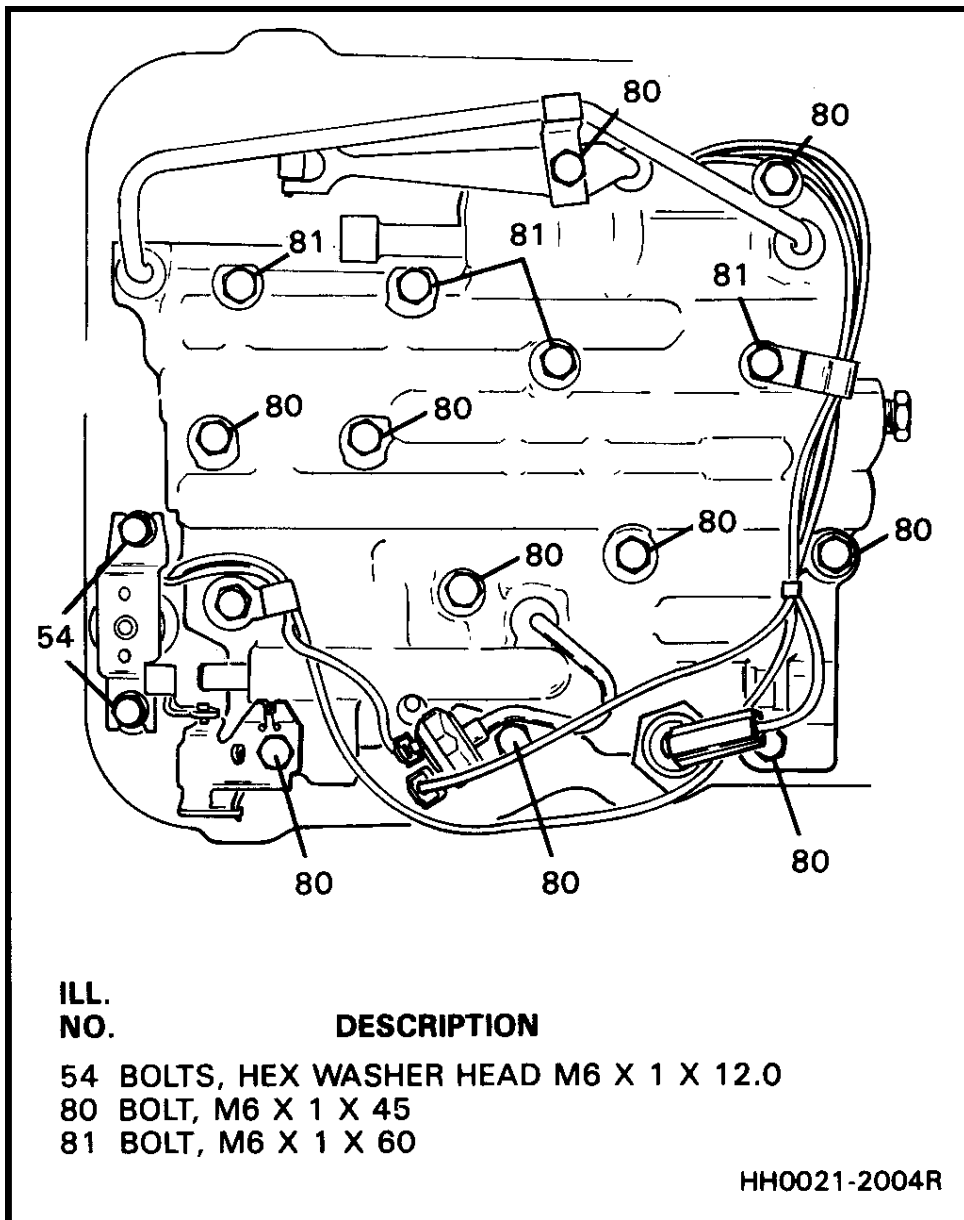

OIL PUMP SCHEMATIC

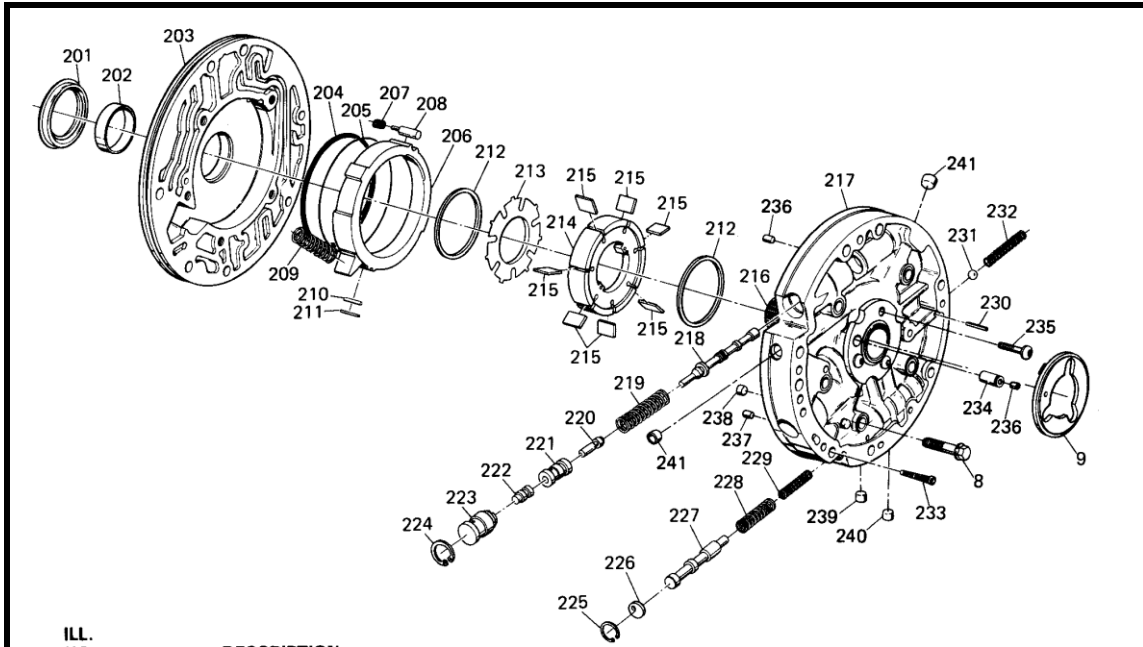

**ILL.
NO.**

DESCRIPTION

- 8 BOLT, PUMP COVER TO BODY
- 9 WASHER, THRUST (HOUSING TO PUMP)
- 201 SEAL, HELIX (PUMP BODY) (FRONT)
- 202 BUSHING, PUMP BODY
- 203 BODY, PUMP
- 204 RING, OIL SEAL (SLIDE TO WEAR PLATE)
- 205 SEAL, "O" RING (SLIDE SEAL BACK-UP)
- 206 SLIDE, PUMP
- 207 SPRING, PIVOT PIN
- 208 PIN, PIVOT SLIDE
- 209 SPRING, PUMP SLIDE (INNER/OUTER)
- 210 SUPPORT, PUMP SLIDE SEAL
- 211 SEAL, PUMP SLIDE
- 212 RING, PUMP VANE
- 213 GUIDE, ROTOR
- 214 ROTOR, OIL PUMP
- 215 VANE, PUMP
- 216 SHAFT & FLANGE ASSEMBLY, STATOR
- 217 COVER, PUMP
- 218 VALVE, PRESSURE REGULATOR
- 219 SPRING, PRESSURE REGULATOR VALVE
- 220 VALVE, REVERSE BOOST
- 221 BUSHING, REVERSE BOOST VALVE
- 222 VALVE, T.V. BOOST
- 223 BUSHING, T.V. BOOST VALVE
- 224 RING, SNAP PRESSURE REGULATOR CASE
- 225 RING, SNAP (CONVERTER CL. PUMP VALVE RET.)
- 226 STOP, VALVE (CONVERTER CLUTCH)
- 227 VALVE, CONVERTER CLUTCH
- 228 SPRING, CONVERTER CLUTCH VALVE (OUTER)
- 229 SPRING, CONVERTER CLUTCH VALVE (INNER)
- 230 RIVET, FLAT HEAD (.156 X 1.0)
- 231 BALL, PRESSURE RELIEF
- 232 SPRING, PRESSURE RELIEF
- 233 SCREEN ASSEMBLY, GOVERNOR
- 234 PIN, DOWEL (PUMP COVER)
- 235 SCREW, SOCKET BUTTON HEAD (M6 X 1 X 16)
- 236 PLUG, CUP (SELECTIVE WASHER LUBE) (2)
- 237 PLUG, ORIFICE (CONV. CLUTCH SIGNAL) 4.84 DIA.
- 238 PLUG, ORIFICE (COOLER FEED) 6.84 DIA.
- 239 PLUG, CUP (COOLER FEED) 6.8 DIA.
- 240 PLUG, CUP (CLUTCH RELEASE) 6.8 DIA.
- 241 PLUG, CUP (LINE/CASE) .511 DIA. (2)

HH0110200.4B

Locate the pressure regulator assembly in this kit. Locate its position in the front pump of the transmission. Its bore in the oil pump is to the left of the bore that the oil filter is inserted into. Study the front pump illustration on the previous page and note the orientation of items 224, 223,222,221,220, and 219. Remove the snap ring (224) that retains the pressure regulator assembly into its bore. Remember that the parts are spring loaded and will pop out once the snap ring has been removed. Remove and discard item numbers 223,222,219, and 218. These items are included in this kit and are installed to improve oil pressure. Using the oil pump illustration and the photo below reinstall the updated pressure regulator assembly components into their bore in the oil pump. Coating the revised pressure regulator valve with Vaseline will help retain it in the bore while fitting the remaining pressure regulator assembly components. Be sure that the snap ring (218) is completely seated into its groove before proceeding. It is sometimes necessary to gently tap the boost valve inward to allow full installation of the snap ring into its groove. Never skip over installation of the tv boost valve assembly. Its installation is critical to optimum product performance.

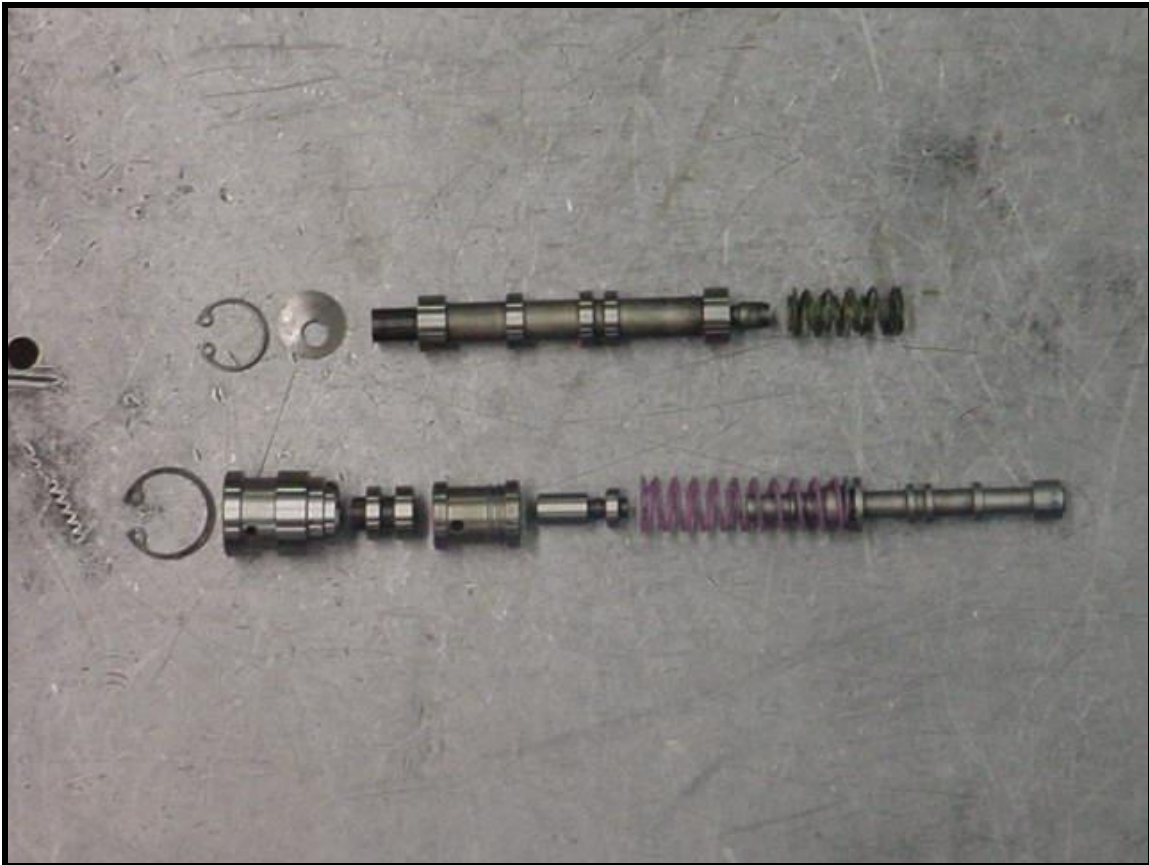

24RCC/PSBISA CK PERFORMANCE 2004R PRO STREET BILLET INTERMEDIATE SERVO ASSEMBLY

INSTALLATION INSTRUCTIONS

This servo has the largest apply area compared to any other servo of its kind. This increase in surface area multiplies the clamping force used to apply the intermediate band during 1-2 upshifts and speeds the release the intermediate band during 2-3 upshifts. It will furnish firm, positive shifts into second and third gears at all throttle angles, greatly increasing the transmissions torque capacity. The piston and cover fit tightly together as part of their design.

To gain access to the servo assembly, remove the servo cover retaining ring (15). Remove all the remaining components from the servo bore using the supplied diagram. Remove items 16, 17, 18, 19, 20, 21, and 22. These parts will not be used during reassembly. If the intermediate servo cushion spring (23) is missing, you must locate and install a replacement.

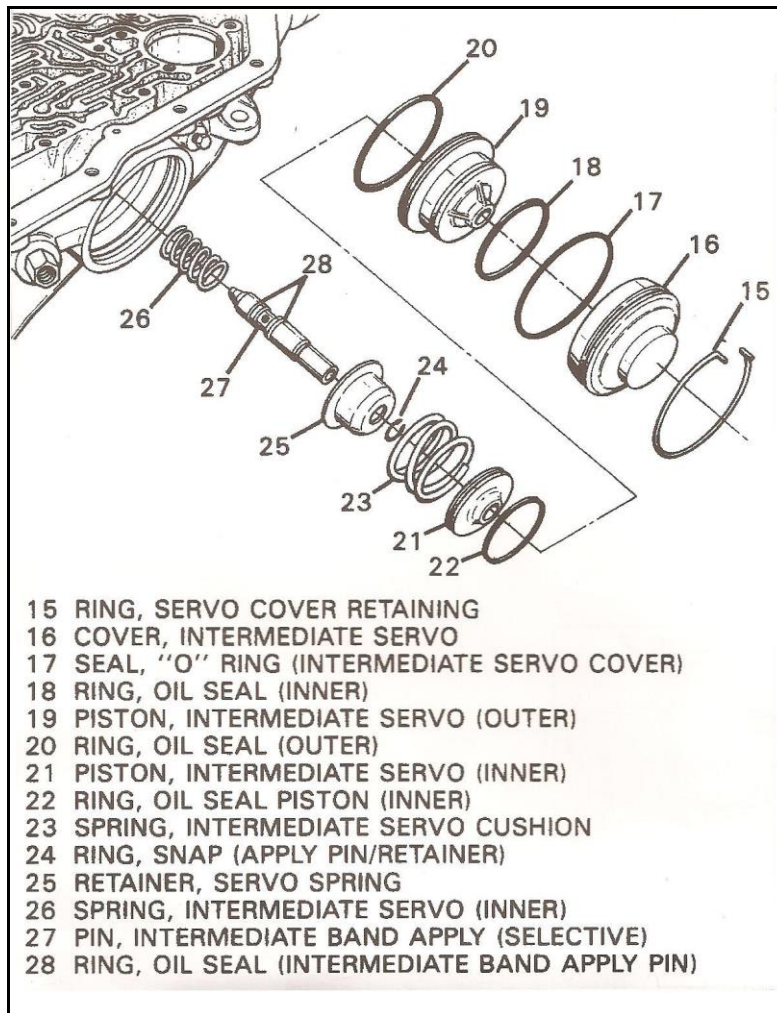

Before servo assembly you must shorten the overall length of the Intermediate Servo Apply Pin (27) by @ .225" to .250". The material is removed from the outer or Servo Cushion Spring (23) end of the apply pin. See Figure 1. This is easily performed with a bench grinder. Be sure to grind a small chamfer after shortening that will allow the pin to easily install and slide freely in the servo pin bore present in the center of the servo assembly.



FIGURE 1

Install the thinnest supplied servo shim into the intermediate servo piston and fit the Intermediate Servo Apply Pin to the replacement servo assembly. See Figures 2 and 3. Install the servo assembly into its bore in the transmission case. Be sure to lube the bore prior to installation and verify the servo cover retaining ring is fully seated in its groove. When the servo assembly is pushed in firmly using your body weight behind the handle of a rubber mallet, or a fully loaded servo installation tool, the clearance between the retaining ring (15) and the intermediate servo cover (16) should be approximately .125". If clearance is over the specification, install the supplied extra shim and recheck clearance. If clearance is under the specification, use a shorter band apply pin as they are selective, or grind the INBOARD END of the pin that contacts the band until specification is met.



FIGURE 2

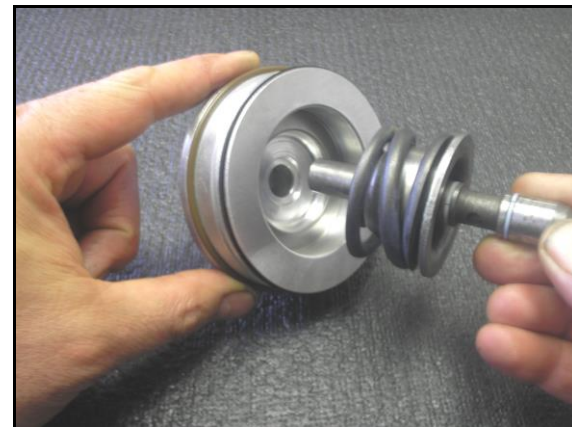

FIGURE 3