

**2005
Honda ARX1200T2/N2
AQUATRAX R-12X/R-12
OWNER'S MANUAL**

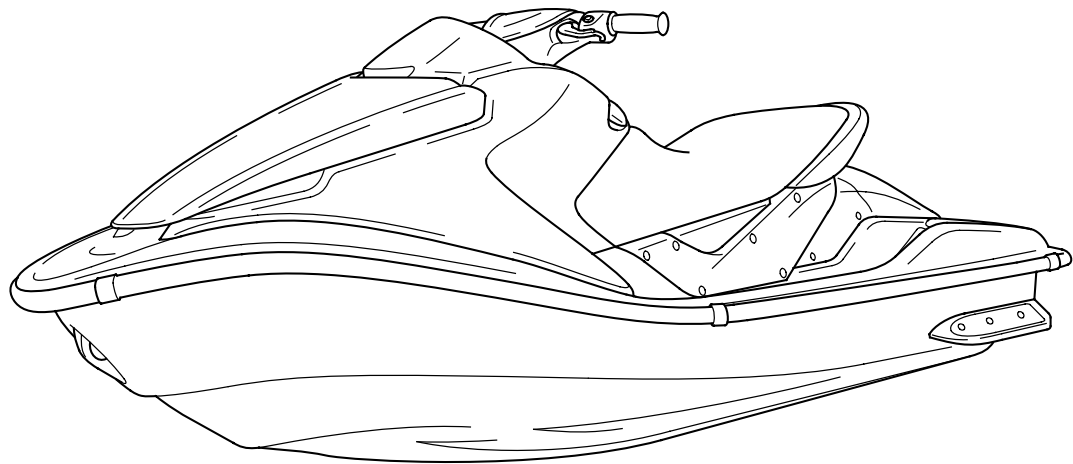

Introduction

Congratulations on choosing your Honda personal watercraft (PWC).

When you own a Honda, you're part of a worldwide family of satisfied customers — people who appreciate Honda's reputation for building quality into every product.

Your Honda was designed as a recreational PWC for use by one operator and one passenger.

Before riding, take time to get acquainted with your PWC and how it works. To protect your investment, we urge you to take responsibility for keeping your PWC well maintained. Scheduled service is a must, of course. But it's just as important to observe the break-in guidelines, and perform all pre-ride checks and post-ride maintenance detailed in this manual.

We also recommend that you read this owner's manual before you ride. It's full of facts, instructions, safety information, and helpful tips. To make it easy to use, the manual contains a table of contents, a detailed list of topics at the beginning of each section, and an index at the back of the book.

As you read this manual, you will find information that is preceded by a **NOTICE** symbol. This information is intended to help you avoid damage to your Honda, other property, or the environment.

Read the Warranties Booklet (page 223) thoroughly so you understand the coverages that protect your new Honda and are aware of your rights and responsibilities.

As a PWC owner, you have joined a larger community of riders who want to ensure that there are places to ride. So when you ride, be considerate of other boaters, swimmers, and people on shore. Keep noise levels down, don't jump wakes, and only ride in areas where it's legal to ride PWCs.

If you have any questions about your PWC, or if you ever need special service or repairs, remember that your Honda PWC dealer knows your PWC best and is dedicated to your complete satisfaction.

Please report any change of address or ownership to your Honda PWC dealer so we will be able to contact you concerning important production information.

You may also want to visit our website at www.honda.com.

For a list of authorized Honda PWC dealers, please refer to the following website: www.hondamotorcycle.com, or call customer service at 1-310-532-9811.

Happy riding!

California Proposition 65 Warning

WARNING: Engine exhaust, some of its constituents, and certain vehicle components contain or emit chemicals known to the State of California to cause cancer and birth defects or other reproductive harm.

A Few Words About Safety

Your safety, and the safety of others, is very important. And operating this PWC safely is an important responsibility.

To help you make informed decisions about safety, we have provided operating procedures and other information on labels and in this manual. This information alerts you to potential hazards that could hurt you or others.

Of course, it is not practical or possible to warn you about all hazards associated with operating or maintaining a PWC. You must use your own good judgment.

You will find important safety information in a variety of forms, including :

- **Safety Labels** — on the PWC.
- **Safety Messages** — preceded by a safety alert symbol ▲ and one of three signal words : **DANGER, WARNING, or CAUTION.**

These signal words mean :

A Few Words About Safety

DANGER

You **WILL** be **KILLED** or **SERIOUSLY HURT** if you don't follow instructions.

WARNING

You **CAN** be **KILLED** or **SERIOUSLY HURT** if you don't follow instructions.

CAUTION

You **CAN** be **HURT** if you don't follow instructions.

- **Safety Headings** — such as Important Safety Reminders or Important Safety Precautions.
- **Safety Section** — such as PWC Safety.
- **Instructions** — how to use this PWC correctly and safely.

This entire manual is filled with important safety information — please read it carefully.

Contents

These pages give an overview of the contents of your owner's manual. The first page of each section lists the topics covered in that section.

PWC Safety 1

Important safety information you should know, plus a look at the safety related labels on your PWC.

Instruments & Controls 11

The location and function of indicators and controls on your PWC and operating instructions for various controls and features.

Before Riding 51

The importance of wearing a personal flotation device (PFD) and other protective gear, how to make sure you and your PWC are ready to ride, and important information about loading.

Basic Operation & Riding 67

How to start and stop the engine, and operate the PWC. Also, riding precautions and important information about launching your PWC and riding with a passenger.

Contents

Servicing Your Honda 99

Why your PWC needs regular maintenance, what you need to know before servicing your Honda, an owner maintenance schedule, and instructions for specific maintenance and adjustment items.

Tips 169

How to store and transport your PWC and how to be an environmentally-responsible rider.

Taking Care of the Unexpected 181

What to do if you capsizes, your engine won't start, etc.

Technical Information 201

Serial numbers, technical specifications, and other technical facts.

Consumer Information 219

Information on warranties, emission controls, how to get Honda service manuals, and...

“Reporting Safety Defects” 228

Table of Contents 230

Sequential listing of topics in this owner's manual.

Index 234

Quick Reference

Handy facts about fuel, engine oil, and spark plugs.

This section presents some of the most important information and recommendations to help you operate your PWC safely. Please take a few moments to read these pages. This section also includes information about the location of safety labels on your PWC.

Important Safety Information2
Safety Labels6

Important Safety Information

Your Honda PWC is a high performance boat, not a toy. Honda recommends that it be operated by someone at least 16 years old.

Your PWC can provide many years of service and pleasure – if you take responsibility for your safety and understand the challenges you can meet while riding.

There is much that you can do to protect yourself when you ride. You'll find many helpful recommendations throughout this manual. The following are a few that we consider most important.

Avoid Collisions

The most common type of PWC accident is colliding with another vessel. In addition, collisions result in more injuries and deaths than any other type of PWC accident.

Understanding how your PWC operates is key to avoid collisions. Your PWC does not have brakes, so you must plan ahead if you are slowing to a stop. Your PWC is propelled by jet thrust (page 69), so the engine must be on with throttle applied to accelerate or turn. Without jet thrust, you will not be able to steer (page 88).

Important Safety Information

Ride Defensively

Watching out for other water users around you and knowing the rules of the waterway can help you out of trouble (page 70). Keep a safe distance away from people, objects, and other watercraft. Remember that if you are on a collision course, it's your responsibility to avoid the collision. For other riding tips, see the *Personal Watercraft Rider's Handbook* that came with your PWC.

Wear a PFD and Protective Clothing

When you ride your PWC, you must wear a Coast Guard-approved Type I, II or III PFD (personal flotation device). It's the law in all states, and it could save your life. In addition, you should wear appropriate protective clothing, including a wet suit bottom or equivalent, footwear, gloves and eye protection (page 53).

Important Safety Information

Get Training

According to the Coast Guard, more than 85% of all fatalities involved people who did not have boating instruction. You can receive boating and PWC instruction from a number of different agencies (page 55).

Even if you have ridden other PWCs, take time to become familiar with how this PWC works and handles. Practice in a safe area, away from boats and swimmers, until you build your skills and get accustomed to the PWC's size and handling.

Ride within Your Limits

Pushing limits can increase the risk of loss of control and collision. Never ride beyond your personal abilities or faster than conditions permit. Remember that alcohol, drugs, fatigue, and inattention can significantly reduce your ability to make good judgements and ride safely.

Don't Drink and Ride

Alcohol and boating don't mix. Even one drink can reduce your ability to respond to changing conditions, and your reaction time gets worse with every additional drink. So don't drink and ride, and don't let your friends drink and ride either.

Important Safety Information

Keep Your Honda in Safe Condition

It's important to keep your PWC properly maintained and in safe riding condition. To help avoid problems, inspect your PWC before every ride and perform all recommended maintenance. Never exceed load limits (page 61), and do not remove any original equipment or modify your PWC in any way that would change its design or operation.

Safety Labels

Safety labels on your PWC either warn you of potential hazards that could cause serious injury or they provide important safety information. Read these labels carefully and don't remove them.

If a label comes off or becomes hard to read, contact your Honda PWC dealer for a replacement.

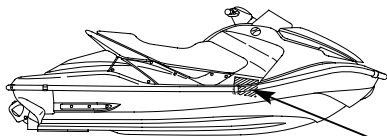

⚠ WARNING

To reduce the risk of SEVERE INJURY or DEATH:

WEAR A PERSONAL FLOTATION DEVICE (PFD). All riders must wear a Coast Guard approved PFD that is suitable for personal watercraft (PWC) use.

WEAR PROTECTIVE CLOTHING. Severe internal injuries can occur if water is forced into body cavities as a result of falling into water or being near jet thrust nozzle. Normal swimwear does not adequately protect against forceful water entry into lower body cavities. All riders must wear a wet suit bottom or clothing that provides equivalent protection (See Owner's Manual). Footwear, gloves, and goggles/glasses are recommended.

KNOW BOATING LAWS. Honda recommends a minimum operator age of 16 years old. Know the operator age and training requirements for your state. A boating safety course is recommended and may be required in your state.

ATTACH ENGINE SHUT-OFF CORD (LANYARD) to wrist and keep it free from handlebars so that engine stops if operator falls off. After riding, remove cord from PWC to avoid unauthorized use by children or others.

RIDE WITHIN YOUR LIMITS AND AVOID AGGRESSIVE MANEUVERS to reduce the risk of loss of control, ejection, and collision. This is a high performance boat - not a toy. Sharp turns or jumping wakes or waves can increase the risk of back/spinal injury (paralysis), facial injuries, and broken legs, ankles, and other bones. Do not jump wakes or waves.

DO NOT APPLY THROTTLE WHEN ANYONE IS AT REAR OF PWC - turn engine off or keep engine at idle. Water and/or debris exiting jet thrust nozzle can cause severe injury.

KEEP AWAY FROM INTAKE GRATE while engine is on. Items such as long hair, loose clothing, or PFD straps can become entangled in moving parts resulting in severe injury or drowning.

NEVER RIDE AFTER CONSUMING DRUGS OR ALCOHOL

READ AND FOLLOW OWNER'S MANUAL



PFD
Wet Suit Bottom



Jet Thrust Nozzle
Intake Grate

⚠ WARNING

Collisions result in more **INJURIES AND DEATHS** than any other type of accident for personal watercraft (PWC).

TO AVOID COLLISIONS:
SCAN CONSTANTLY for people, objects, and other watercraft. Be alert for conditions that limit your visibility or block your vision of others.



OPERATE DEFENSIVELY at safe speeds and keep a safe distance away from people, objects, and other watercraft.

- Do not follow directly behind PWCs or other boats.
- Do not go near others to spray or splash them with water.
- Avoid sharp turns or other maneuvers that make it hard for others to avoid you or understand where you are going.
- Avoid areas with submerged objects or shallow water.

TAKE EARLY ACTION to avoid collisions. Remember, PWCs and other boats do not have brakes.

DO NOT RELEASE THROTTLE WHEN TRYING TO STEER away from objects
- you need throttle to steer.

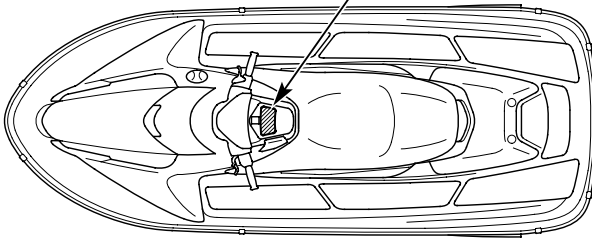
Always check throttle and steering controls for proper operation before starting PWC.
Follow navigation rules and state and local laws that apply to PWCs.
See Owner's Manual for more information.



(cont'd)

Safety Labels

⚠ WARNING

Overloading or improperly loading the PWC can make it difficult to control and could result in an accident. See Owner's Manual for loading information.

⚠ WARNING

Starting the engine without ventilating the engine compartment can cause a fire or explosion. See Owner's Manual.

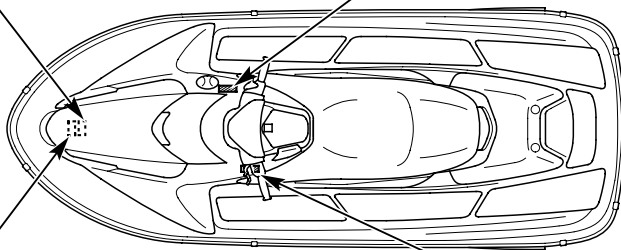

⚠ WARNING

Storing fuel in this compartment can be a fire or explosion hazard which can result in injury or death. Do not store fuel or other flammable liquids in this unventilated compartment.

⚠ WARNING

Shifting to reverse while moving forward can cause abrupt deceleration. You and your passenger can be seriously injured. See Owner's Manual.

Safety Labels

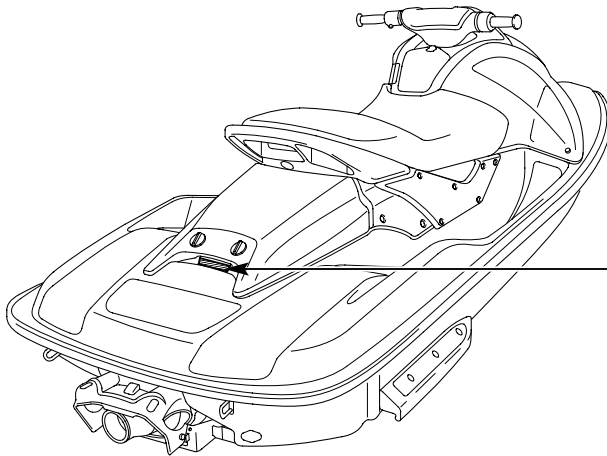

Maximum capacity is 2 persons but do not exceed a maximum weight of 338lbs (153.5kg)

Instruments & Controls

This section shows the location of all gauges, indicators, and controls you would normally use before or while riding your PWC.

The items listed on this page are described in this section. Instructions for other components are presented in other sections of this manual where they will be most useful.

Component Locations	13
Multi-function Display	19
SET Button	26
MODE Button	26
ID SET Button	27
ID No. Button	27
Low Oil Pressure Indicator	28
Engine Cooling Water Temperature Indicator	29
Low Battery Voltage Indicator	30
Fuel Gauge and Low Fuel Indicator	31
Digital Clock	32

(cont'd)

Instruments & Controls

Controls & Features	34
ID Lock System	34
Limit Mode	39
Start Button	40
Engine Stop Button/Switch	40
Safety Lanyard & Lock Clip	41
Handlebar	42
Throttle Lever	42
Trim Lever	43
Reverse Lever	45
Jet Pump Water Intake	46
Cooling Water Bypass Outlet	46
Bilge Drain Plugs	47
Flushing Connector	47
Jet Pump Steering Nozzle	48
Bow & Stern Eyelets	49
Grab Rail	50

Component Locations

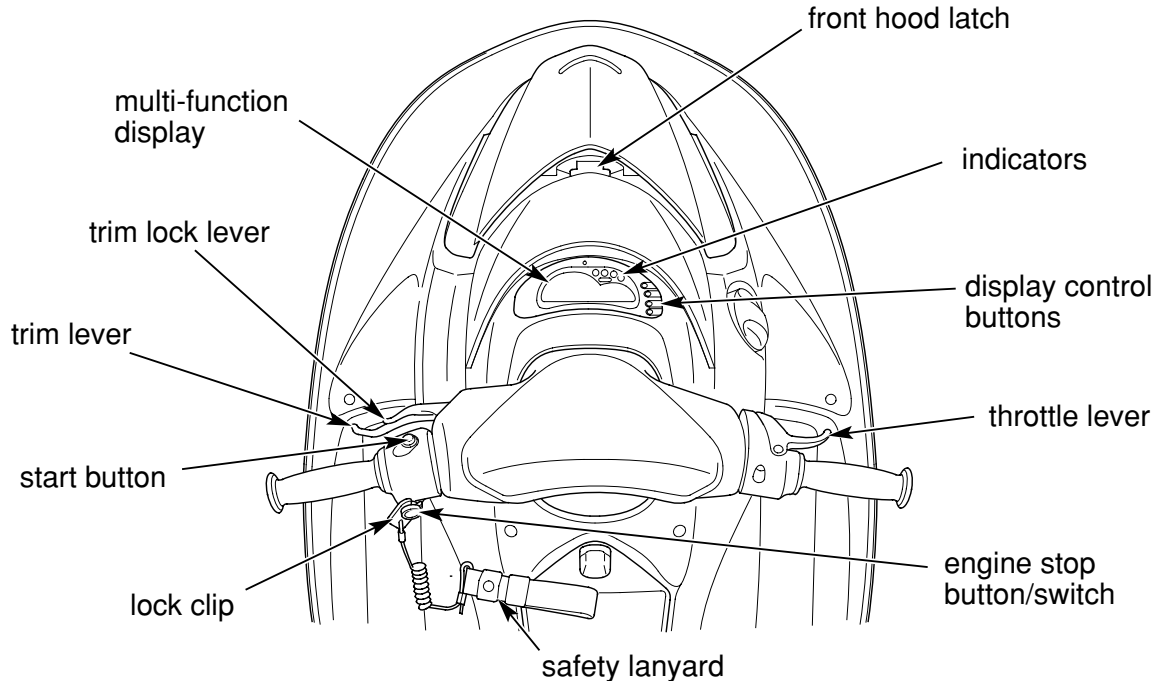

Component Locations

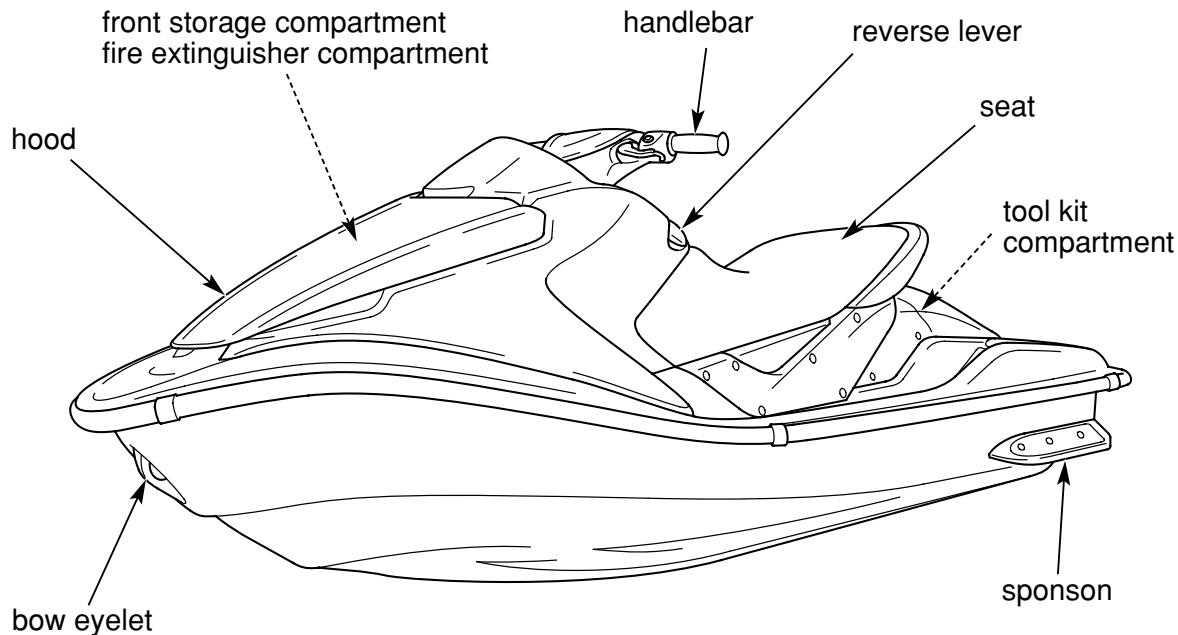

Component Locations

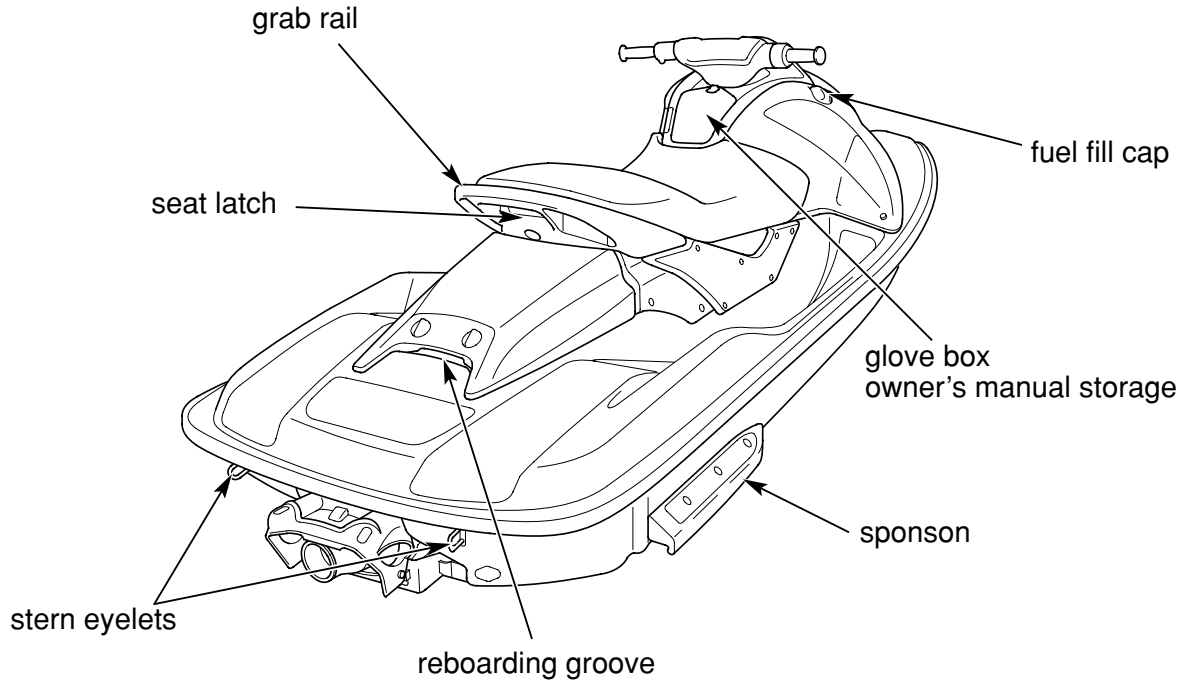

Component Locations

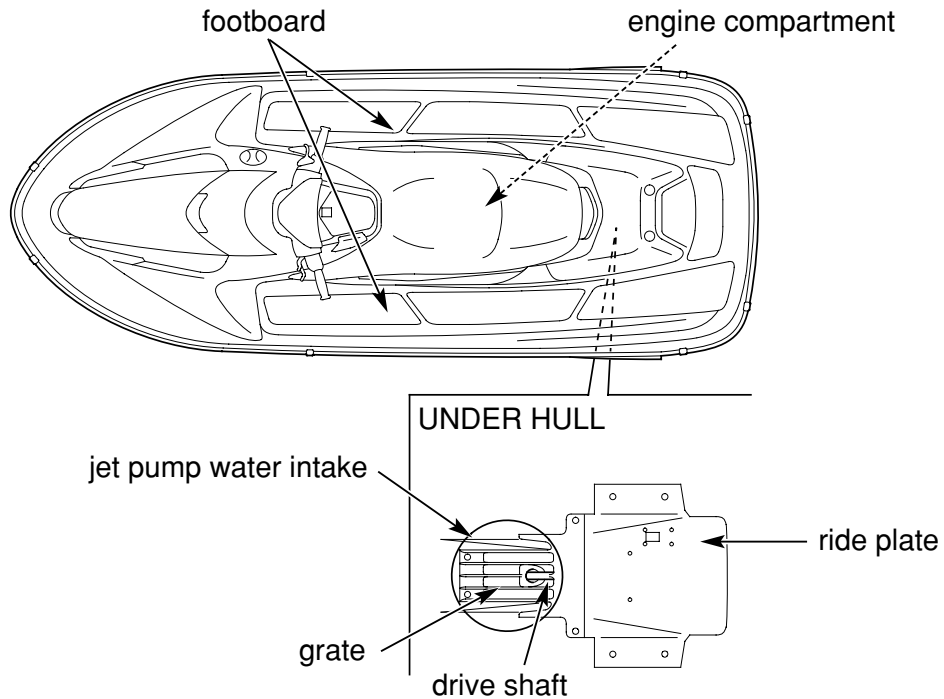

Component Locations

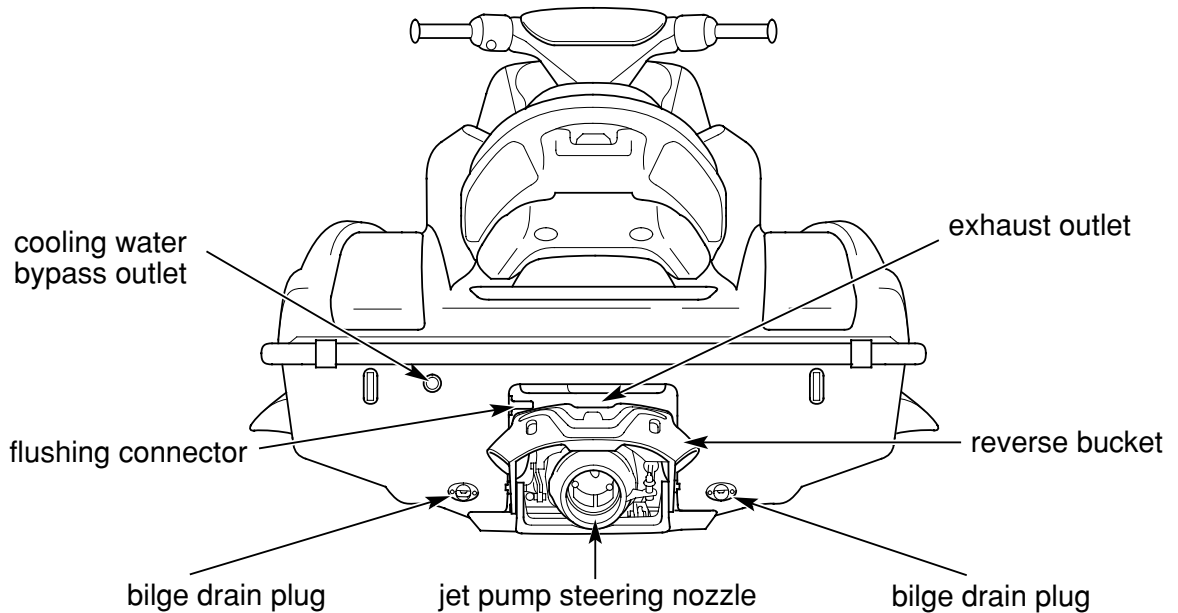

Component Locations

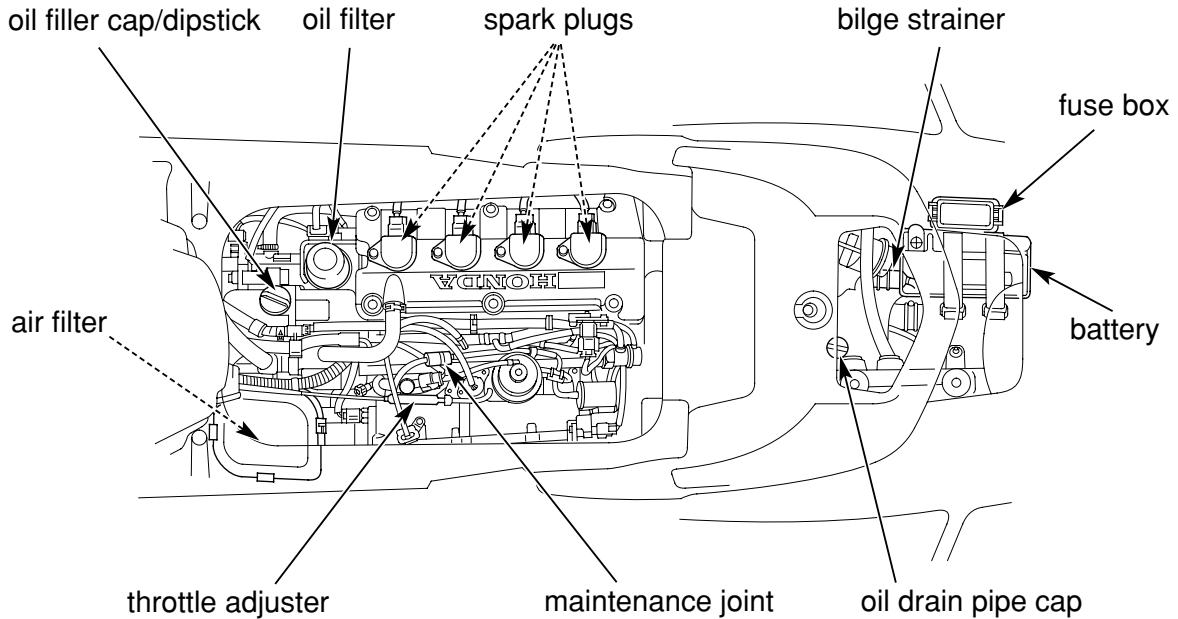

Multi-function Display

The multi-function display and beeper on your PWC keep you informed, alert you to possible problems, and make your riding more enjoyable. Refer to the display frequently. Its functions are described on the following pages.

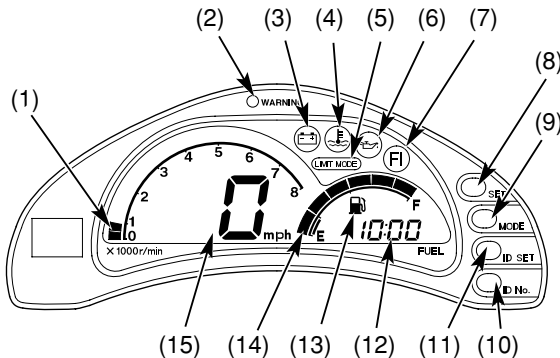

- (1) tachometer
- (2) WARNING lamp
- (3) low battery voltage indicator
- (4) engine cooling water temperature indicator
- (5) LIMIT MODE indicator
- (6) low oil pressure indicator
- (7) PGM-FI malfunction indicator lamp (MIL)
- (8) SET button
- (9) MODE button
- (10) ID No. button
- (11) ID SET button
- (12) multi-function meter
- (13) low fuel indicator
- (14) fuel gauge
- (15) speedometer

Multi-function Display

Display Check

After inserting the lock clip in the engine stop button/switch or after releasing the ID lock system, the beeper sounds twice and all the segments of the multi-function display, except the tachometer, will appear. Then all tachometer segments will turn on and off in sequence. After the check is complete, you will see the normal displays.

If any part of these displays does not come on when it should, have your Honda PWC dealer check for problems.

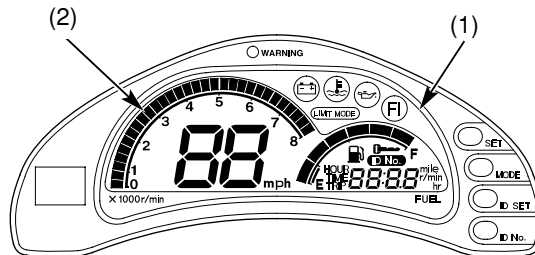

- (1) multi-function display
- (2) tachometer

Multi-function Display

1	tachometer	Shows engine speed in revolutions per minute (rpm).
2	WARNING lamp	Flashes under the following conditions: (1) The remaining fuel is low. (2) There is a fault in the fuel system. (3) The engine oil pressure is low. (4) The engine cooling water temperature is high. (5) There is any abnormality in the PGM-FI system. (6) The battery voltage is low (below approx. 11.5 V). If the indicator flashes, immediately take the shortest route to land.
3	low battery voltage indicator	Flashes when the battery voltage is below approx. 11.5 V. If the indicator flashes, immediately take the shortest route to land. This indicator is usually off.

Multi-function Display

4	engine cooling water temperature indicator	<p>Flashes when the engine cooling water temperature is high enough to cause engine damage.</p> <p>If the indicator flashes, immediately take the shortest route to land, then see page 186 for instructions and precautions.</p> <p>This indicator is usually off.</p>
5	LIMIT MODE indicator	<p>Comes on when the limit mode is activated and continues to flash while the mode is active (page 39).</p> <p>This indicator is usually off.</p>
6	low oil pressure indicator	<p>Flashes when the engine oil pressure is low enough to cause engine damage.</p> <p>If the indicator flashes, immediately take the shortest route to land, then see page 187 for instructions and cautions.</p> <p>This indicator is usually off.</p>

Multi-function Display

7	PGM-FI malfunction indicator lamp (MIL)	<p>Flashes when there is some abnormality in the PGM-FI (Programmed Fuel Injection) system. Occasionally, depending on the abnormality, engine revs may be limited to less than 3,000 rpm. In extreme cases, the engine will stop.</p> <p>If the indicator flashes, immediately take the shortest route to land.</p> <p>If the engine stops, tow your PWC to land.</p> <p>This indicator is usually off.</p>
8	SET button	<p>Resets the tripmeter and time meter to zero (0) (page 26).</p> <p>Also used to set the digital clock (page 32).</p>
9	MODE button	<p>Selects the mode of the multi-function meter: digital clock, tachometer, time meter, tripmeter, hourmeter.</p> <p>Selects ON or OFF for the limit mode.</p> <p>Also used to set the digital clock (page 32).</p>

Multi-function Display

10	ID No. button	Selects or changes the ID number (page 34). Also used to switch the display to the set up condition of the ID number (page 34).
11	ID SET button	Enters or cancels the ID number. Also used to activate the ID lock system.
12	multi-function meter	The meter includes the following functions:
	digital clock (*)	Shows hour and minute (page 32).
	tachometer	Shows engine speed in revolutions per minute (rpm).
	time meter (*)	Shows the hours and minutes of engine operation since you last reset the meter. To reset the time meter to zero (0), press and hold the SET button.
	tripmeter (*)	Shows the number of miles ridden since you last reset the meter. To reset the tripmeter to zero (0), press and hold the SET button.
	hourmeter	Shows the total hours of engine operation. Check the hourmeter to determine when the next scheduled maintenance is due.

*If the battery is disconnected, the digital clock, tripmeter, and time meter will reset.

Multi-function Display

13	low fuel indicator	Flashes when the fuel remaining in the tank is about: 3.41 US gal (12.9 ℓ)
14	fuel gauge	Shows approximate fuel supply available (page 31). When segment F goes on, the fuel tank capacity is: 16.64 US gal (63.0 ℓ) When segment E flashes while riding, fuel remaining in the tank is about: 3.41 US gal (12.9 ℓ)
15	speedometer	Shows approximate riding speed in miles per hour.

Multi-function Display

SET Button

The SET button is used to set the digital clock (page 32).





The SET button is also used to reset (zero) the tripmeter and time meter. To reset the tripmeter and time meter, press and hold the button for about 2 seconds.

MODE Button

The MODE button is used to set the digital clock (page 32).

The MODE button is also used to switch between 5 displays (digital clock, tachometer, time meter, tripmeter and hourmeter). To switch from one display to another, push the button.

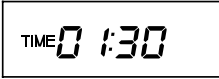
The MODE button is also used to select the limit mode. To select the limit mode, press and hold the button for at least 5 seconds with the engine off (page 39).

digital clock	
tachometer	
time meter	
tripmeter	
hourmeter	

ID SET Button

The ID SET button is used to enter the ID number. To enter the number, push the button (page 34).

The ID SET button is also used to activate the ID lock system.

ID No. Button

The ID No. button is used to select an ID number. To select a number, push the button (page 34).

The ID No. button is also used to switch the display to the set up condition of the ID number. To switch, press and hold the button.

Multi-function Display

Low Oil Pressure Indicator

The low oil pressure indicator (1) and the WARNING lamp (2) flash and the warning beeper sounds when engine oil pressure is low enough to cause engine damage. The engine automatically slows to prevent damage.

To stop the warning beeper, press and hold any one of the four control buttons (SET, MODE, ID SET, or ID No.) for about 2 seconds.

If this occurs, head for shore and turn the engine OFF. See page 187 for instructions and cautions.

NOTICE

Continuing to ride with low oil pressure can cause serious engine damage.

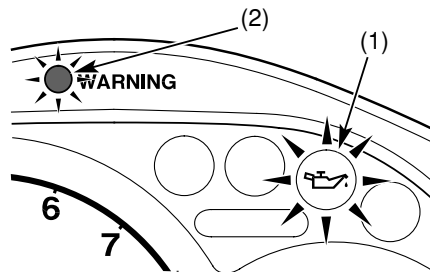

- (1) low oil pressure indicator
- (2) WARNING lamp

Engine Cooling Water Temperature Indicator

The engine cooling water temperature indicator (1) and the WARNING lamp (2) flash and the warning beeper sounds when the engine cooling water is over the specified temperature. The engine automatically slows to prevent damage.

To stop the warning beeper, press and hold any one of the four control buttons (SET, MODE, ID SET, or ID No.) for about 2 seconds.

If this occurs, head for shore and turn the engine OFF. See page 186 for instruction and precautions.

NOTICE

Continuing to ride with an overheated engine can cause serious engine damage.

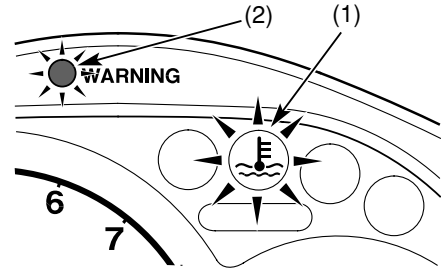

- (1) engine cooling water temperature indicator
- (2) WARNING lamp

Multi-function Display

Low Battery Voltage Indicator

If the battery voltage is low (below approx. 11.5 V), the low battery voltage indicator (1) and the WARNING lamp (2) flash and the warning beeper sounds.

To stop the warning beeper, press and hold any one of the four control buttons (SET, MODE, ID SET, or ID No.) for about 2 seconds.

If the low battery voltage indicator and the WARNING lamp flash before leaving shore, charge the battery (page 164). If the indicator still flashes after charging, see your Honda PWC dealer.

If the indicator and WARNING lamp flash and the beeper sounds while riding, immediately head for shore and see your Honda PWC dealer as soon as possible.

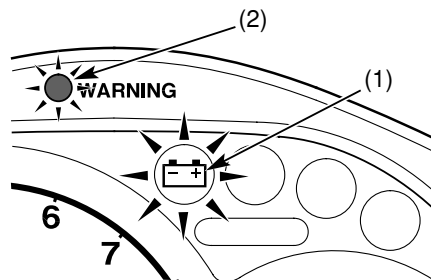

- (1) low battery voltage indicator
- (2) WARNING lamp

Multi-function Display

Fuel Gauge and Low Fuel Indicator

The fuel gauge liquid crystal display (1) shows the approximate fuel supply available. The fuel tank capacity is:
16.64 US gal (63.0 ℓ)

When segment E (2), the low fuel indicator (3) and WARNING lamp flash and the warning beeper sounds, you should refill the tank as soon as possible. The amount of fuel remaining when the flashing starts is approximately:
3.41 US gal (12.9 ℓ)

To stop the warning beeper, press and hold any one of the four control buttons (SET, MODE, ID SET, or ID No.) for about 2 seconds.



(1) fuel gauge display

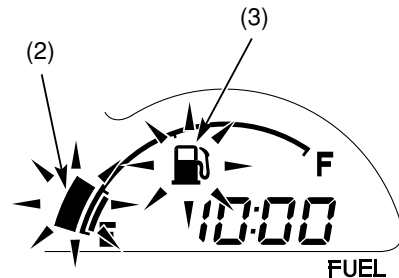

(2) segment E

(3) low fuel indicator

Multi-function Display

Digital Clock

Shows hour and minute. To adjust the time, proceed as follows:

1. Insert the lock clip in the engine stop button/switch to turn on the display. If necessary, enter the ID number after this operation (page 37).
2. Switch the multi-function meter (1) to the digital clock mode by pushing the MODE button (2).
3. Press and hold the SET button (3) for at least 2 seconds. The clock will be set in the adjust mode with the hour display flashing.

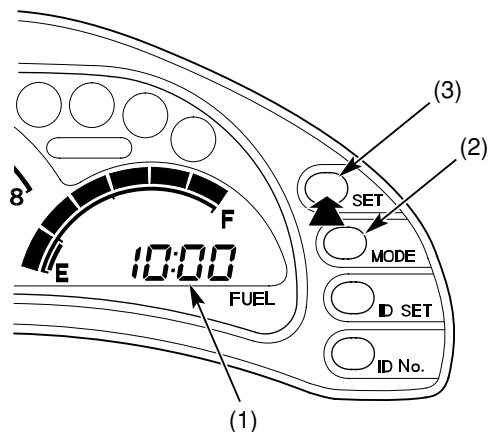

- (1) multi-function meter
- (2) MODE button
- (3) SET button

Multi-function Display

4. To set the hour, push the MODE button (2) until the desired hour appears.
 - Quick setting – press and hold the MODE button until the desired hour appears.
5. Push the SET button. The minute display will start flashing.
6. To set the minute, push the MODE button until the desired minute appears.
 - Quick setting – press and hold the MODE button until the desired minute appears.
7. To end the adjustment, press the SET button or pull the lock clip out of the engine stop button/switch.

The display will stop flashing automatically and the adjustment will be cancelled if the button is not pressed within 30 seconds.

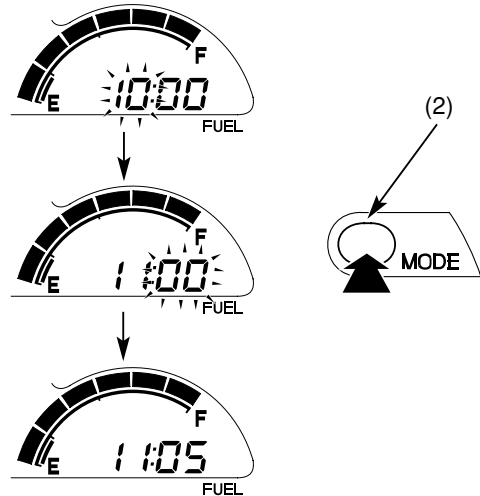

(2) MODE button

Controls & Features

ID Lock System

Your PWC is equipped with an ID lock system that prevents the engine being started by anyone who doesn't have the ID number.

To Create an ID number

1. Insert the lock clip in the engine stop button/switch to turn on the display.
2. Press and hold the ID No. button (1) for at least 2 seconds. The display will switch to the entry mode with the ID No. mark (2) and the first digit of the ID number flashing. The beeper sounds once.

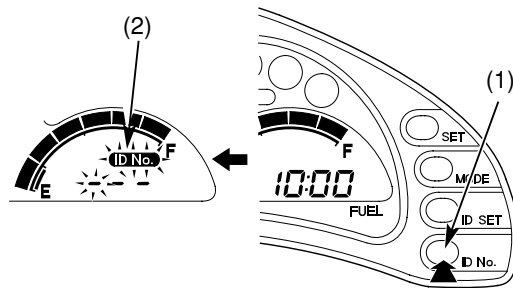

(1) ID No. button (2) ID No. mark

Controls & Features

3. Push the ID No. button until the desired number is displayed.
4. Push the ID SET button (3), the second digit of ID number display will start flashing.
5. Repeat steps 3 and 4 two more times to select all three digits.
 - To advance the number, press and hold the ID No. button.
6. After all three digits flash, press and hold the ID SET button.
In this time, push the ID SET button once, the number will cancel.

The beeper will sound once after entry is completed.

”000” cannot be used as an ID number.

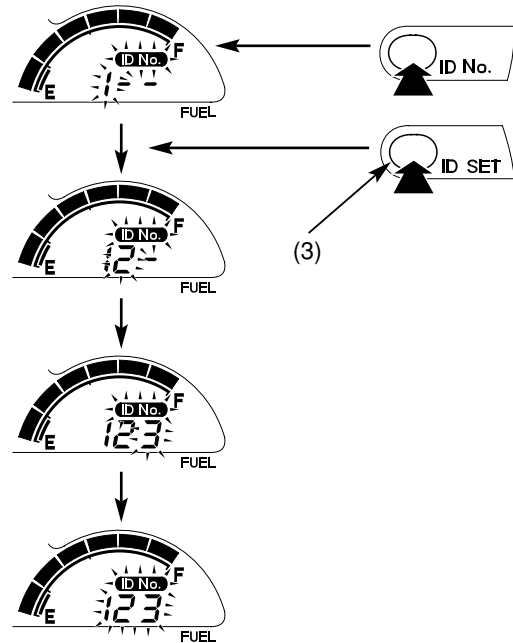

(3) ID SET button

Controls & Features

To Activate the Lock System

1. With the engine OFF, press and hold the ID SET button for at least 2 seconds when the multi-function display goes on. The key mark (4) will start flashing.
2. Push the ID SET button once. The key mark will go on and the first digit of the ID number will start flashing and the beeper sounds once.
3. Pull the lock clip out of the engine stop button/switch.

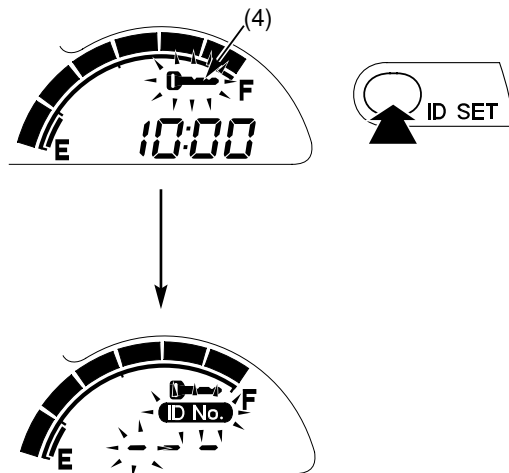

(4) key mark

To Deactivate the Lock System

1. Insert the lock clip in the engine stop button/switch to turn on the display.
2. Follow steps 3-6 under *To Create an ID Number* (page 35).

If the number you entered is correct, the beeper will sound twice, and the engine may be started. If you enter the wrong number, you are allowed two more attempts. After three failures to enter the correct number, the display will turn off.

In order to try again, remove and insert the lock clip.

If you forget the ID number and have not recorded it elsewhere, contact your Honda PWC dealer.

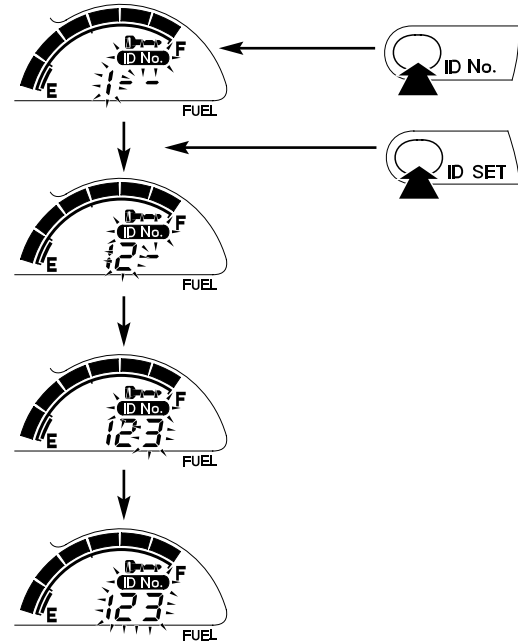

Controls & Features

To Change the ID Number

1. Insert the lock clip in the engine stop button/switch to turn on the display.
2. Press and hold the ID No. button for at least 2 seconds. The display will switch to the change mode with the ID No. mark and first digit of ID number appearing.
3. Enter the current number.
4. Enter the new number.
5. To register the new number, press and hold the ID SET button.

After the change is completed, the beeper will sound once.

”000” cannot be used as an ID number.

Limit Mode

The limit mode restricts the speed of your PWC (approx. 35 mph) to allow new riders to become accustomed to its operation. Anyone riding this PWC for the first time should use this mode and practice basic operation of the PWC to become familiar with the behavior of the PWC.

To Activate the Limit Mode

- With the engine off, press and hold the MODE button (1) for at least 5 seconds until the LIMIT MODE indicator (2) goes on.

When this mode is active while riding, the LIMIT MODE indicator flashes. When the indicator flashes, release the throttle slightly.

To Cancel the Limit Mode

- With the engine off, press and hold the MODE button for more than 5 seconds until the LIMIT MODE indicator goes off.

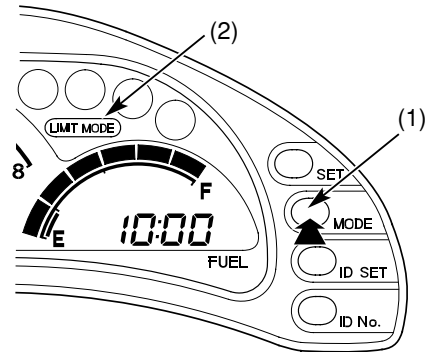

- (1) MODE button
(2) LIMIT MODE indicator

Controls & Features

Start Button

The green start button (1) is used for starting the engine. See *Starting Procedure*, page 75.

The engine will not start if the ID lock system is active.

Engine Stop Button/Switch

The red engine stop button/switch (2) is used to stop the engine. To operate, push the button. See *How to Stop the Engine*, page 78.

LEFT HANDLEBAR

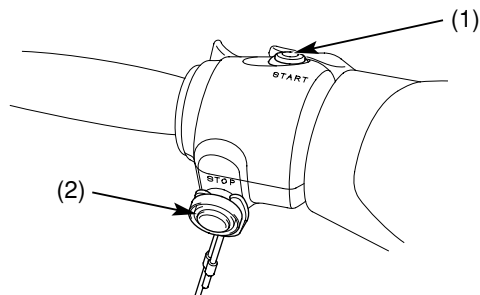

- (1) start button
- (2) engine stop button/switch

Safety Lanyard & Lock Clip

The safety lanyard (1) should be worn around the operator's left wrist. Before starting the engine, insert the lock clip (2) in the engine stop button/switch.

If the operator falls overboard or away from the controls, the engine will stop immediately when the lock clip is pulled away from the engine stop button/switch.

To prevent theft or accidental starting, remove the lock clip from the engine stop button/switch and take the safety lanyard with you when you leave your PWC.

LEFT HANDLEBAR

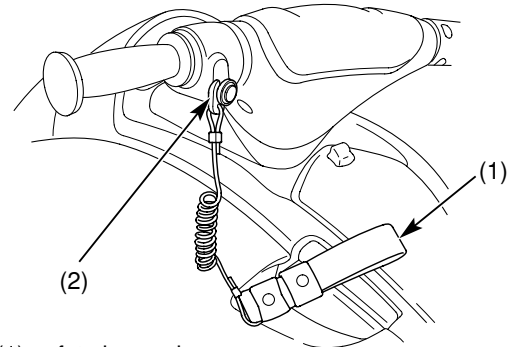

- (1) safety lanyard
- (2) lock clip

Controls & Features

Handlebar

The handlebar is used to steer your PWC. (Turning the PWC also requires applying some throttle.)

Throttle Lever

The throttle lever (1) is used to control engine rpm (speed). To go faster, pull the lever toward you. To go slower, reduce pressure to allow the lever to move away from you. The throttle lever will automatically return to the closed position (engine idle) when you let go off the lever.

RIGHT HANDLEBAR

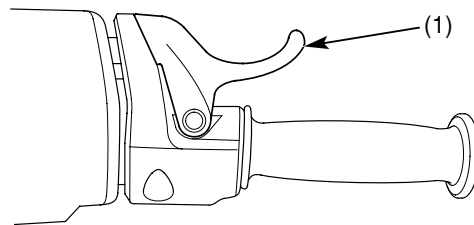

(1) throttle lever

Trim Lever

The trim lever (1) adjusts the front/rear planing attitude of your PWC. Pulling the trim lever lowers the bow and improves:

- acceleration from a standing start
- turning performance
- riding stability with a passenger aboard

There is no clutch or brake function in the trim lever.

LEFT HANDLEBAR

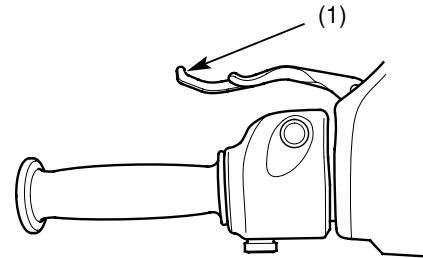

(1) trim lever

Controls & Features

The trim lever (1) can be locked.

To lock, pull the trim lever and push the trim lock lever (2) forward.

To unlock the trim lever, pull the trim lock lever.

LEFT HANDLEBAR

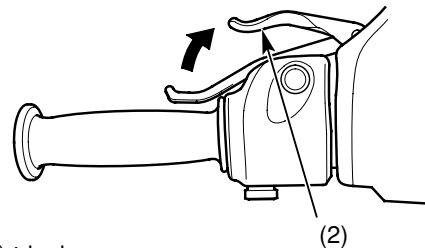
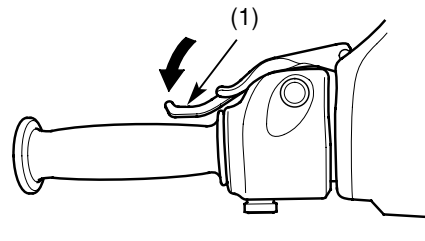

- (1) trim lever
- (2) trim lock lever

Reverse Lever

The reverse lever (1) is used to select reverse operation. Squeeze the trigger (2) and pull the reverse lever toward you to lower the reverse bucket (3) over the jet pump steering nozzle. This reverses the direction of the water thrust. To cancel reverse operation, push the lever forward until the trigger locks.

See *Reverse Operation*, page 91.

LEFT SIDE

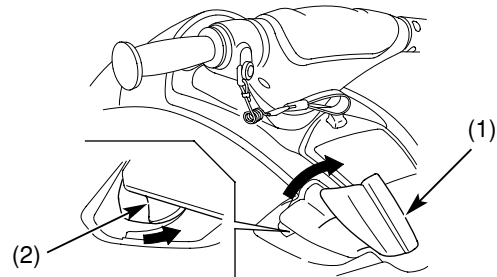

(1) reverse lever

(2) trigger

REAR

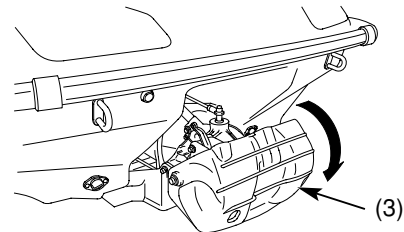

(3) reverse bucket

Controls & Features

Jet Pump Water Intake

The jet pump water intake (1) draws water into the propulsion system. A grate (2) helps to screen out debris.

UNDER HULL

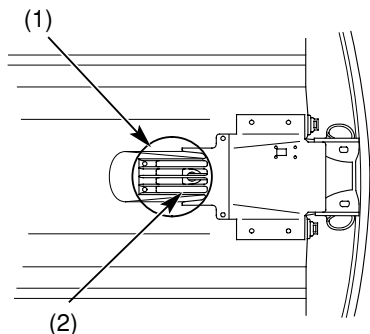

- (1) jet pump water intake
- (2) grate

Cooling Water Bypass Outlet

The cooling water bypass outlet (1) is used to check that water is circulating properly in the engine cooling system while the engine is running. If you don't see water flowing out of the outlet, stop the engine. Check for possible causes of the problem (page 198).

REAR

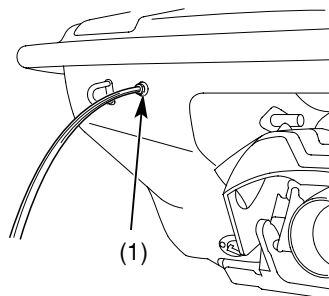

- (1) cooling water bypass outlet

Bilge Drain Plugs

The two bilge drain plugs (1) are used to drain water from the engine compartment. This operation should be performed with your PWC out of the water and the engine off. The plugs must be secured before returning your PWC to the water to avoid possible engine damage.

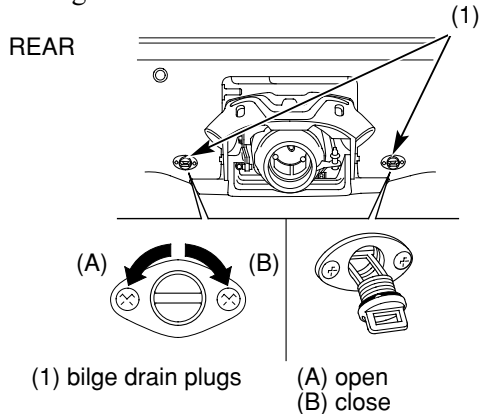

Flushing Connector

The flushing connector (1) is used for attaching a garden hose to flush the engine cooling system (page 154).

REAR

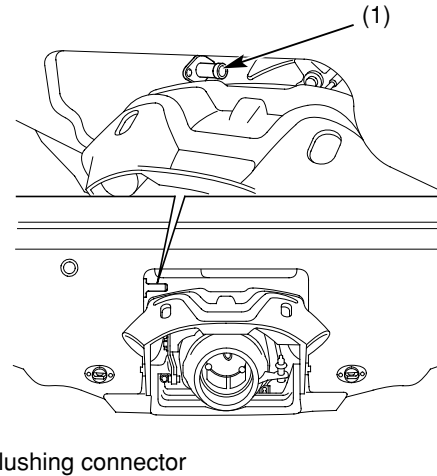

Controls & Features

Jet Pump Steering Nozzle

The jet pump steering nozzle (1) directs the water thrust that propels and turns your PWC. Turning the handlebar (2) turns the nozzle.

FRONT/REAR

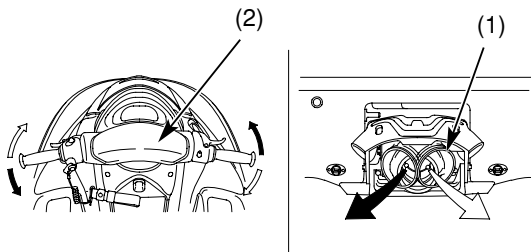

- (1) jet pump steering nozzle
- (2) handlebar

Bow & Stern Eyelets

The bow (front) and stern (rear) eyelets (1) (2) are used for mooring your PWC or securing it on its trailer.

The bow eyelet can also be used if your PWC requires towing on water.

FRONT

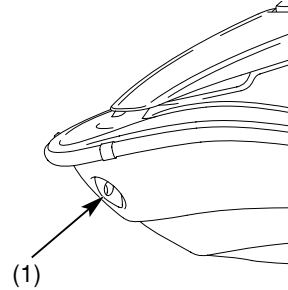

(1) bow eyelet

REAR

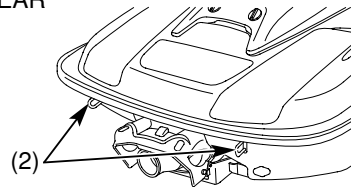

(2) stern eyelets

Controls & Features

Grab Rail

The grab rail (1) is used to assist boarding. The grab rail should not be used for towing, lifting the PWC, or for attaching tie downs.

REAR

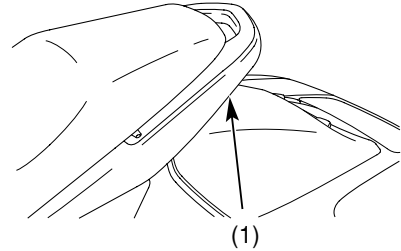

(1) grab rail

Before each ride, you need to make sure you, your passenger and your Honda are all ready to ride. To help get you prepared, this section discusses how to evaluate your riding readiness, what items you should check on your PWC, and adjustments to make for your comfort, convenience, or safety. This section also includes important information about loading.

Are You Ready to Ride?	52
Protective Apparel	52
Operator Training	55
Is Your PWC Ready to Ride?	56
Pre-ride Inspection	56
Load Limits & Guidelines	61
Load Limits	61
Loading Guidelines	62
Cargo Compartments	63
Glove Box	63
Front Storage Compartment	64
Fire Extinguisher Compartment	66

Are You Ready To Ride?

Before you ride your PWC for the first time, we urge you to:

- Read this owner's manual.
- Make sure you understand all the safety messages.
- Know how to operate all the controls.
- Know local boating and PWC laws.

Before each ride, be sure:

- You feel well and are in good physical and mental condition.
- You are wearing a PFD (personal flotation device) and a wet suit bottom or clothing that provides equivalent protection.
- You don't have any alcohol or drugs in your system.

Make sure your passenger is ready to ride too, and is wearing proper protective clothing and a PFD.

Check with local authorities to find out what local boating laws apply to the area you'll be riding in. You'll want to find out things like whether it's legal to operate your PWC in a certain body of water, what the minimum PWC operator age is, and whether or not you need proof of training in order to operate a PWC. Honda recommends that operators are at least 16 years old before operating this PWC.

Protective Apparel

For your safety, we strongly recommend that you and your passenger always wear an approved PFD, eye protection, footwear, gloves, and a wet suit bottom whenever you ride. Although complete protection is not possible, wearing proper gear can reduce the chance of injury when you ride. Following are suggestions to help you and your passenger choose the proper gear.

Are You Ready To Ride?

PFDs

Any time you board your PWC, you should wear a Coast Guard-approved Type I, II or III PFD. Your PFD is your most important piece of safety apparel because it offers the best protection against drowning.

A PFD should fit you properly and securely. A bright colored PFD can make you more noticeable in the water.

⚠ WARNING

Not wearing a PFD increases the chance of drowning if you fall overboard.

Be sure you and your passenger always wear a PFD and other protective apparel when you ride.

Additional Riding Gear

In addition to a PFD, we also recommend:

- A wet suit bottom to protect yourself against severe internal injuries caused by strong streams of water from the jet nozzle forced into body cavities.
- Eye protection to keep water spray and wind out of your eyes.
- Foot protection to give better grip on the floorboards.
- Neoprene gloves to give better grip on the handlebar.

Are You Ready To Ride?

Helmets

A helmet can offer some head protection in a collision or impact, but it can also cause severe injuries in other situations.

PWC helmets are designed to provide some head protection, and could reduce your risk of injury if you collide with another vessel or object while riding.

However, if you fall into water while riding and the helmet catches the water's surface as you fall, that helmet could cause choking, severe neck injuries or death.

You should decide for yourself whether or not to wear a helmet when riding your PWC. Think about the conditions and environment in which you'll be riding. Will the water be crowded or open? Smooth or choppy? Shallow and rocky or deep? Each time you ride, you'll need to decide if a helmet is necessary.

Are You Ready To Ride?

Operator Training

Developing your riding skills is an on-going process. Even if you have ridden other PWCs, take time to become familiar with how this PWC works and handles.

Practice riding the PWC in calm water close to shore to build your skills. Do not ride farther out until you get accustomed to the PWC's controls and feel comfortable with the way it handles.

We urge all riders to take a certified course approved by the U.S. Coast Guard or U.S. Power Squadron, or by your state. For boating safety course information in your area, call your nearest U.S. Coast Guard Auxiliary, U.S. Power Squadron, Red Cross, or state boating law enforcement office, or call the Boat/U.S. Foundation Course Hotline, 1-800-336-BOAT. The national number for the Coast Guard Customer Info Line is (800) 368-5647.

You can find more boating safety information on-line:

- the U.S.C.G. Office of Boating Safety:
www.uscgboating.org
- the U.S. Power Squadron:
www.usps.org

Other riding tips can be found in the *Personal Watercraft Rider's Handbook* booklet that came with your PWC.

Is Your PWC Ready To Ride?

Before each ride it's important to inspect your PWC and make sure any problem you find is corrected. A pre-ride inspection is a must, not only for safety, but because having a problem on the water can be a major inconvenience.

⚠ WARNING

Improperly maintaining this personal watercraft or failing to correct a problem before riding can cause a crash in which you can be seriously hurt or killed.

Always perform a pre-ride inspection before every ride and correct any problems.

Before inspection, make sure the lock clip is not inserted in the engine stop button/switch. Check the following items before putting your PWC in the water.

Pre-ride Inspection

Check the following items before starting the engine:

<i>Engine</i>	Remove the seat and the front storage box to vent gasoline fumes. (Reinstall the seat and the front storage box before launching.)
<i>Compartment</i>	

⚠ WARNING

Starting the engine without ventilating the engine compartment can cause a fire or explosion and you or others could be seriously injured or killed.

Always vent the engine compartment before starting the engine.

Is Your PWC Ready To Ride?

<i>Bilge</i>	Look for water, oil or fuel in the engine compartment. Drain, if necessary.
<i>Leaks</i>	Look for signs of leaking fuel or oil in the engine compartment.
<i>Fire Extinguisher</i>	Check the fire extinguisher is properly secured in its compartment. Check for damage. Make sure the locking pin and sealing wire are in place. Check the pressure gauge and expiration date.

<i>Steering</i>	Check that there is no sticking or looseness when turning the handlebar.
<i>Throttle</i>	Check the freeplay and adjust if necessary. Pull the throttle lever to make sure it moves smoothly without sticking, and snaps shut automatically when it is released, in all steering positions.

(cont'd)

Is Your PWC Ready To Ride?

Safety Lanyard

Check that the lanyard is in good condition and the lock clip is securely attached. Replace if necessary.

Fuel Level

Insert the lock clip in the engine stop button/switch and check the fuel gauge. Remove the lock clip. Add fuel, if necessary (page 120).

Reverse System

Pull the reverse lever to make sure it moves smoothly without sticking. Check that the bucket drops over the jet pump steering nozzle.

Hull

Inspect for cracks or damage. Remove any marine growth.

Bilge Drain Plugs

Check that the plugs are secure.

Jet Pump Water Intake

Check that nothing is obstructing the intake grate of the jet pump, driveshaft, cooling water filter, or impeller. Remove any debris.

Loose Parts, Latches

Look for anything that appears unusual. Check that all latches (including the seat) are secure.

Is Your PWC Ready To Ride?

Check these items which require starting and flushing the engine on shore (see *Flushing Procedure*, page 154. If necessary, these procedures may be performed with your PWC on calm water):

Engine Start & Stop Insert the lock clip in the engine stop switch. Push the start button after ventilating the engine compartment. Stop the engine by pushing the engine stop button. Start the engine again and stop it by removing the lock clip.

Engine Cooling System Check that water comes out from the cooling water bypass outlet.

Engine Oil Check the level and add oil if needed (page 126).

Off-throttle Steering System (OTS) Check that the OTS activates properly (page 159).

Is Your PWC Ready To Ride?

If you are carrying a passenger or cargo, also check the following:

Load Limits Make sure you do not exceed the load limits (page 61).

Cargo Check that all cargo is secured in compartments.

Remember, be sure to take care of any problem you find, or have your Honda PWC dealer correct it before you ride.

Load Limits & Guidelines

Your PWC has been designed to carry you and one passenger. When you carry a passenger, you may feel some difference during acceleration, turning and slowing. But so long as you keep your PWC well-maintained, you can safely carry loads within the given limits and guidelines.

However, exceeding the weight limit can seriously impair your PWC's handling and stability. Non-Honda accessories, improper modifications, and poor maintenance can also reduce your safety margin.

Load Limits

Following are the load limits for your PWC:

maximum number of people onboard:
2 persons

maximum weight capacity:
338 lbs (153.5 kg)
includes the weight of the operator,
passenger, all cargo.

maximum storage compartment weights:
Front storage compartment
= 6.6 lbs (3 kg)
Glove box
= 1 lbs (0.5 kg)

Load Limits & Guidelines

Loading Guidelines

Your PWC is primarily intended for transporting you and a passenger.

Do not carry more cargo than the maximum weight capacity allows.

Improperly loading your PWC can affect its stability and handling.

WARNING

Overloading or improper loading can make the personal watercraft difficult to control and could result in an accident.

Follow all load limits and other loading guidelines in this manual.

Follow these guidelines whenever you carry a passenger or cargo:

- Do not place cargo on the seat, deck, or any where else other than the storage compartment or a glove box.
- Do not attach any items to the handlebar.

Cargo Compartments

Glove Box

The glove box (1) is used for storing the owner's manual and small, light articles. Don't store breakable objects in this compartment.

To open, lower the tab (2) and pull the glove box lid (3).

To close the glove box, push the glove box lid (4) back into its position. Make sure the lid is closed securely.

Cargo in the glove box should not exceed:
1 lb (0.5 kg)

If the compartment is flooded, remove the rubber grommet (4) on the bottom of the compartment to drain the water.

FRONT

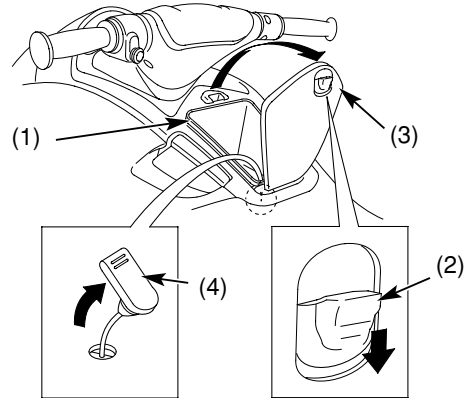

- (1) glove box
- (2) tab
- (3) glove box lid
- (4) rubber grommet

Cargo Compartments

Front Storage Compartment

The front storage compartment may be used to store safety equipment such as towing rope, signal flares, or other small articles. Don't store breakable objects in this compartment.

Fuel and other flammable liquids should never be stored in this compartment.

⚠ WARNING

Storing fuel in the front storage compartment can cause a fire or explosion that can result in injury or death.

Do not store fuel or other flammable liquids in this unventilated compartment.

Cargo Compartments

To open the front storage compartment (1), pull the hood latch (2) and lift the hood (3).

To close the storage compartment, lower the hood. Check that the latch is secure.

Cargo in the front storage compartment should not exceed:

6.6 lbs (3 kg)

If the compartment is flooded, remove the rubber grommet (4) on the bottom of the compartment to drain the water.

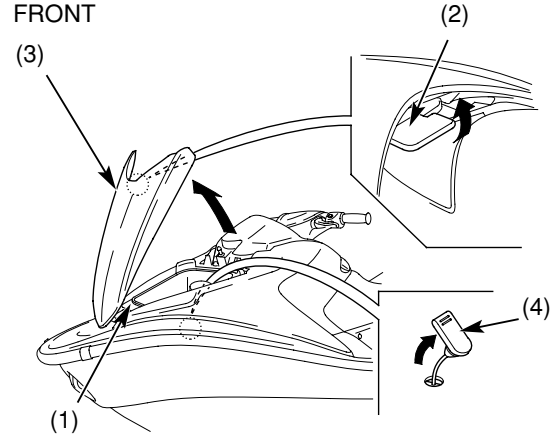

- (1) front storage compartment
- (2) hood latch
- (3) hood
- (4) rubber grommet

Cargo Compartments

Fire Extinguisher Compartment

The fire extinguisher compartment (1) is located in the front storage compartment (page 64).

Your PWC is classified as a Class A inboard boat. The Coast Guard requires that you carry a B-1 classification fire extinguisher. Many local and state boating laws also require a U.S. Coast Guard-approved fire extinguisher.

Your PWC is not delivered with a fire extinguisher as standard equipment. To obtain a suitable fire extinguisher, consult your Honda PWC dealer, a marine supply store or a fire extinguisher manufacturer in your area.

To open the lid (2), turn it counterclockwise.

To close the lid, turn it clockwise.

FRONT

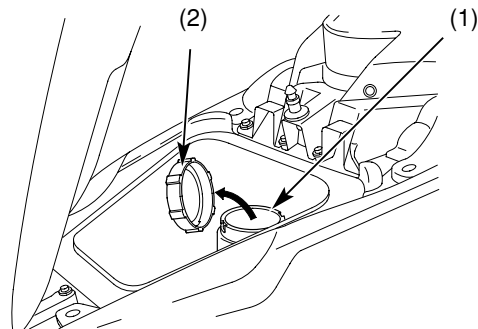

- (1) fire extinguisher compartment
- (2) lid

Basic Operation & Riding

This section gives basic riding instructions, including how to start and stop your engine, and how to use the throttle and trim lever. It also provides navigation rules and important information on riding with a passenger or cargo.

To protect your new engine and enjoy optimum performance and service life, refer to Break-in Guidelines (page 209).

Safe Riding Precautions	68
PWC Propulsion	69
Navigation Rules	70
Starting & Stopping the Engine	74
Preparation	74
Starting Procedure	75
Flooded Engine	77
How to Stop the Engine	78
Launching & Boarding Your PWC	80
Launching from a Ramp	80
Boarding from a Dock	81
Boarding in Shallow Water	82
Boarding in Deep Water	83
Boarding with a Passenger	85
Your First Ride	87
Turning	88
Off-Throttle Steering (OTS)	90
Reverse Operation	91
Stopping/Docking/Beaching	93
Riding with a Passenger or Cargo	95
Post-ride Maintenance	97

Safe Riding Precautions

Before riding your PWC for the first time, please review the *PWC Safety* section beginning on page 1, and the *Before Riding* section beginning on page 51.

Even if you have ridden other PWCs, take time to become familiar with how your PWC works and handles. Practice in a safe area, away from boats and swimmers, until you build your skills and get accustomed to the PWC's size and handling.

Your PWC is not equipped with lights. Do not ride at night.

PWC Propulsion

Your PWC is water-jet propelled. The engine is connected to a driveshaft that rotates an impeller, located within the jet pump housing underneath the PWC. Water, drawn through the intake grate by the spinning impeller, reaches a venturi in the jet pump steering nozzle, which accelerates its flow to increase thrust. Because of this direct-drive design, when the engine is on, your PWC will move slowly.

Pulling the throttle lever increases thrust which increases speed. Turning the handlebar turns the jet pump steering nozzle and allows you to turn.

Releasing pressure on the throttle lever slows the PWC. Without the engine running and without the throttle, there is no propulsion and you cannot steer. Your PWC does not have brakes.

Pulling the trim lever lowers the jet pump steering nozzle. As a result, the bow is lowered and your ride is made more stable.

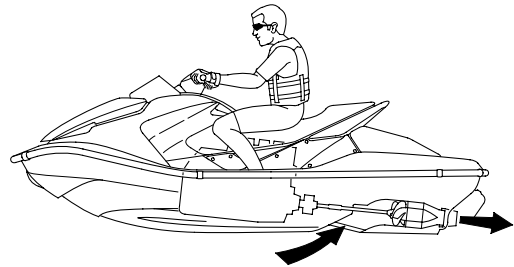

Navigation Rules

Your PWC is classified as a Class A inboard boat. Because of this, you need to know and obey the rules of the waterway. They're like traffic rules, and establish who has the right of way on the water. These rules are used internationally and are enforced by the U.S. Coast Guard and other local agencies.

The information in this section provides the basic rules. We highly recommend that you get more information about navigation from your state when you register your personal watercraft. Take a boat handling and seamanship course from the Coast Guard Auxiliary, the U. S. Power Squadron, or a volunteer organization. These groups can provide you with detailed training on navigation rules and other important information.

Navigation Rules

On to the basics: When two boats are on the water, one boat has the right-of-way and is called the “stand-on” vessel; the other boat must yield or give way and is called the “give-way” vessel.

In the illustration, you are the larger PWC in the center. You must yield to any vessel shown in the white area (you are the give-way vessel). Any vessels in the shaded area must yield to you (you are the stand-on vessel). If you meet head on, you must both give way.

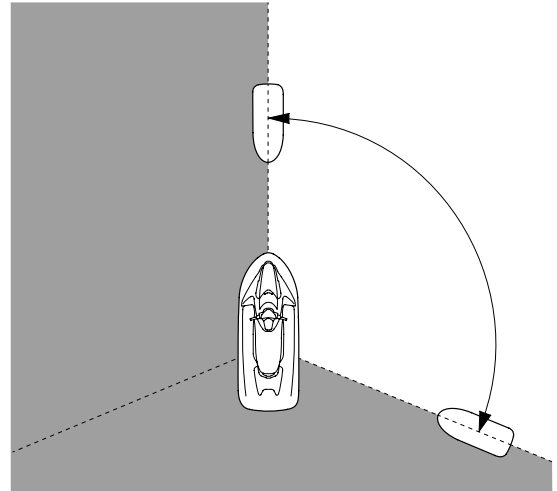

The illustrations on the following pages show stand-on and give-way responsibilities.

Navigation Rules

Meeting: If you are approaching another vessel head-on and are close enough to risk collision, neither of you has the right of way. Both of you should change course to avoid a collision. Keep the other vessel to your left (port) side. This rule does not apply if both of you will clear of one another if you continue on your set course and speed.

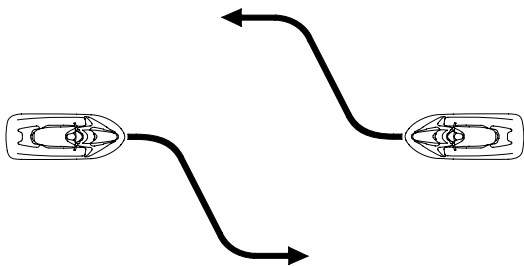

Crossing: If you and another vessel are crossing paths close enough to risk collision, and the other vessel is on your right (starboard), you should yield or stay out of the way. If the other vessel is on your left (port) side, you must maintain your course and speed, as long as the other vessel gives you the right of way as it should.

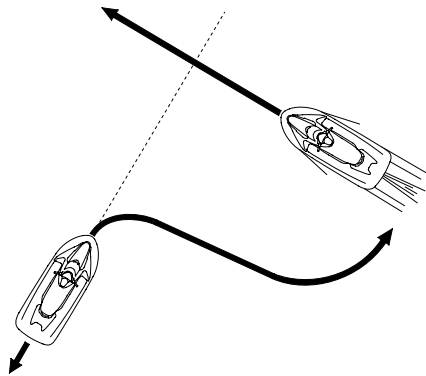

Overtaking or Passing: If you are passing another vessel, you are the give-way vessel. The other vessel is expected to maintain its course and speed. You must stay out of its way until you are clear of it. If another vessel is passing you, you should maintain your course and speed so that the other vessel can steer around you.

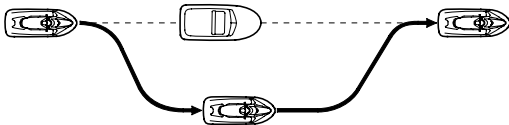

Non-motorized Vessels: Non-motorized vessels such as sailboats and canoes always have the right of way except:

- 1) When the sailing vessel is overtaking a power vessel, the power vessel has the right of way.
- 2) Sailing vessels should keep clear of fishing vessels.
- 3) In a narrow channel, non-motorized vessels cannot interfere with the safe passage of a power vessel.

Starting & Stopping the Engine

Always follow the proper starting procedure described below.

For your safety, avoid starting or operating the engine in an enclosed area such as a garage. Your PWC's exhaust contains poisonous carbon monoxide gas which can collect rapidly in an enclosed area and cause illness or death. Running the engine when your PWC is not in the water can also damage the engine.

Preparation

Before starting, confirm the following:

- Make sure your PWC is in at least 3 feet (90 cm) of water that is free of debris and weeds.

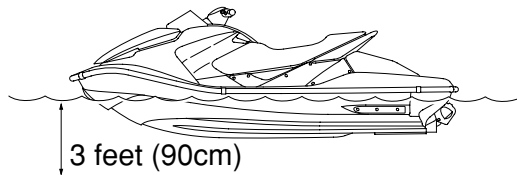

- Push up and down on the rear of your PWC several times to flush out any sand.
- Check that there are no swimmers, boats, or obstacles in the area.

Starting & Stopping the Engine

Starting Procedure

WARNING

When the engine is running, long hair, PFD straps or loose clothing can be sucked into the intake grate and become entangled in the impeller. A person can be held under the water and drown.

- Do not start the engine if anyone is in the water near the personal watercraft.
- Make sure people stay away from the intake grate when the engine is running.

1. Board your PWC, place your feet on the footboard. Make sure your passenger is on board and no one is behind the PWC.

(cont'd)

Starting & Stopping the Engine

2. Attach the safety lanyard (1) to your left wrist.
3. Insert the lock clip (2) in the engine stop button/switch (3).
Be sure the lanyard is not caught or tangled on anything.
4. Punch in your ID number to cancel the ID lock system (page 37), if necessary.
5. Keep the throttle closed to prevent unexpected movement of the PWC, then push the start button.

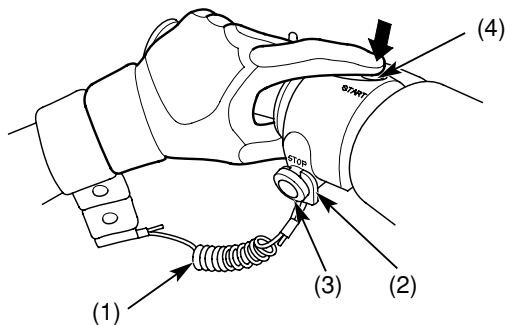

- | | |
|--------------------|-------------------------------|
| (1) safety lanyard | (3) engine stop button/switch |
| (2) lock clip | (4) start button |

Starting & Stopping the Engine

6. Immediately after the engine starts, release the engine start button. The jet pump will be producing thrust and the PWC will move slowly.
7. If the engine does not start within 5 seconds, release the start button and wait 30 seconds before trying again, to avoid discharging the battery or damaging the starter motor.

The starter motor can operate while the display is indicated (10 seconds) even if the lock clip is pulled out from the engine stop button/switch.

Flooded Engine

If the engine fails to start after repeated attempts, it may be flooded with excess fuel. To clear a flooded engine:

1. Open the throttle fully.
2. Press the start button for 5 seconds.
3. Follow the normal starting procedure.
4. If the engine starts, then open the throttle slightly if idling is unstable.
If the engine does not start, wait 10 seconds, then follow steps 1 – 3 again.

If the engine still won't start, refer to *If Your Engine Quits or Won't Start*, page 183.

Starting & Stopping the Engine

How to Stop the Engine

To stop the engine, be sure there is at least 3 feet (90 cm) of water so that debris or weeds can't be drawn into the water inlet system.

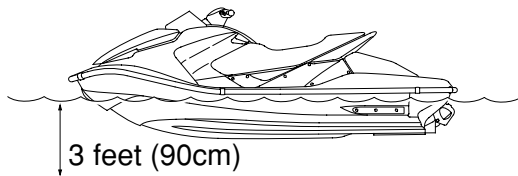

NOTICE

Starting or stopping the engine in less than three feet of water can damage the jet pump if debris or weeds are drawn in.

Release the throttle lever and turn off the engine when you no longer need jet thrust to maintain directional control.

Starting & Stopping the Engine

Wait until the engine is idling, then press the engine stop button/switch (1). (Once the engine stops, you will have no directional control.)

If you are leaving the PWC, activate the ID lock system, remove the lock clip (2) from the engine stop button/switch and take the safety lanyard with you.

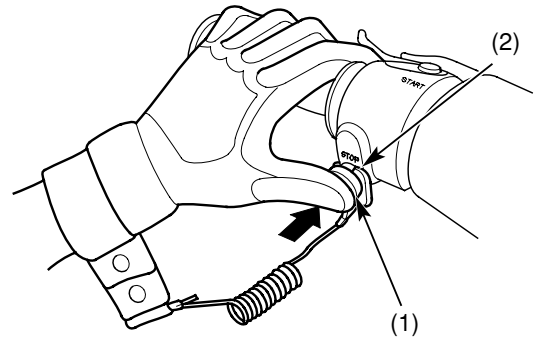

(1) engine stop button/switch

(2) lock clip

Launching & Boarding Your PWC

How you board your PWC is affected by water depth and whether or not you plan to carry a passenger. Once you (and your passenger) are on board, check that your path is clear of other boats, swimmers, or obstacles. Slowly increase throttle as you head toward open water.

Launching from a Ramp

1. Complete the pre-ride inspection (page 56).
2. Check that the ramp is suitable for both your PWC trailer and your tow vehicle, and that the launch area is clear of people and other boats.
3. Attach a bow line to your PWC.
4. Release the tie downs.
5. Back your trailer into the water until the rear of the hull begins to lift.
6. Unlock the winch.
7. Slowly push your PWC into the water and remove the bow line.
8. Slowly move your PWC to a docking area and moor it securely.
9. Move your tow vehicle away from the ramp.

Launching & Boarding Your PWC

Boarding from a Dock

1. Place one foot on the footboard nearest the dock.
2. Hold the handlebar.
3. Transfer your weight to balance the PWC as you place your other foot on the footboard.
4. Start the engine (page 75).
5. Push your PWC away from the dock or apply slight throttle and steer at a slight angle away from the dock until the rear of your PWC clears.

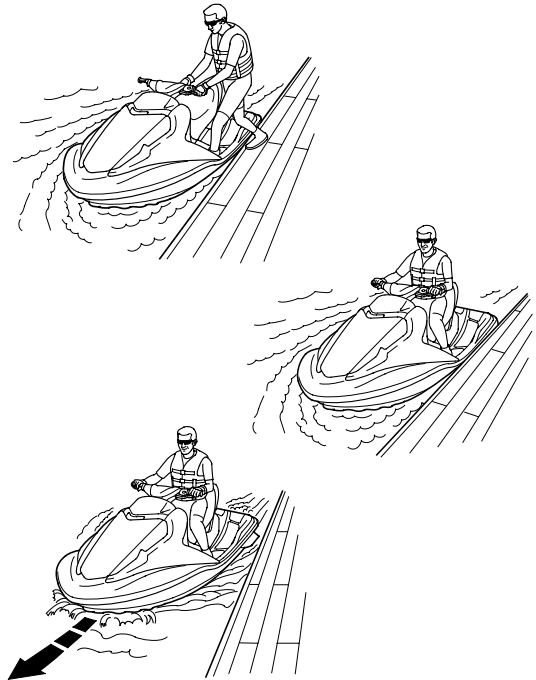

Launching & Boarding Your PWC

Boarding in Shallow Water

1. Make sure the engine is off and your PWC is in at least 3 feet (90 cm) of water.

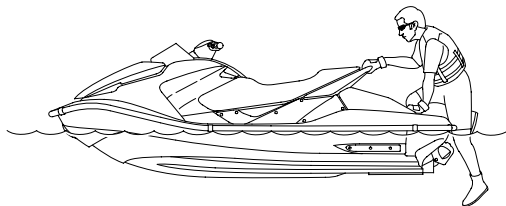

NOTICE

Starting or stopping the engine in less than three feet of water can damage the jet pump if debris or weeds are drawn in.

2. Board from the rear. Balance your PWC as you climb aboard.



Launching & Boarding Your PWC

Boarding in Deep Water

Practice in shallow water before attempting to board in deeper water.
Make sure the engine is off.

1. Move to the rear of the PWC.

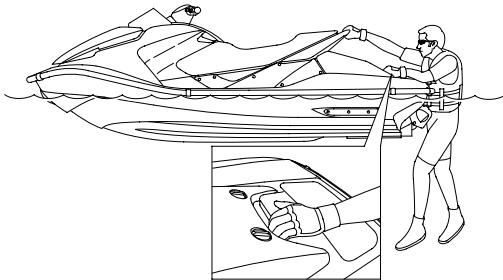

2. Grasp the grab rail and reboarding groove, and pull yourself up until you can place one knee on the rear deck.
3. Bring your other knee onto the rear deck.

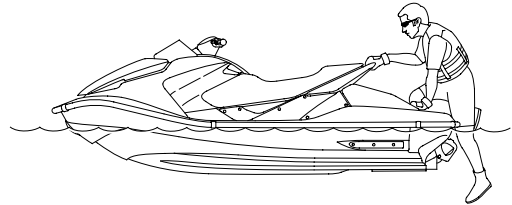

(cont'd)

Launching & Boarding Your PWC

4. Move forward, being careful to balance your PWC.
5. When possible, grasp the handlebar for support.

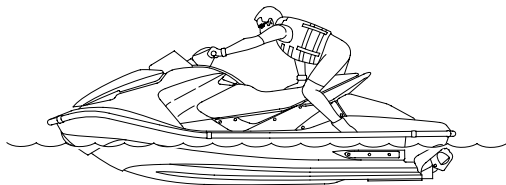

6. Place your feet on the footboards.
7. Sit on the seat.



Launching & Boarding Your PWC

Boarding with a Passenger

For more information on riding with a passenger, see page 95.

⚠ WARNING

If a passenger falls off the back of a personal watercraft after the operator opens the throttle, water can be forced into lower body cavities, causing severe internal injuries.

- Do not start the engine until the passenger is seated properly and holding on.
- All riders should wear a wet suit bottom or equivalent.

1. The passenger should hold the PWC to steady it as the operator climbs on.
2. The operator should get in position on the seat, but not start the engine.
3. The passenger should move to the rear of the PWC.

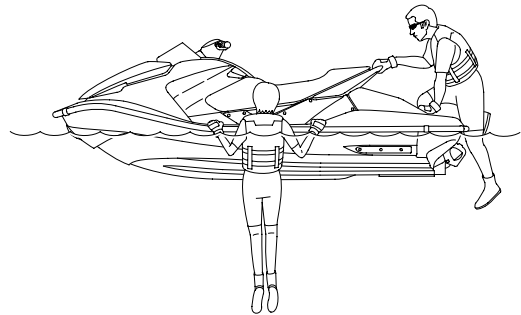

(cont'd)

Launching & Boarding Your PWC

4. The operator should slide forward to give the passenger more space.
5. The passenger should grasp the grab rail and reboarding groove, and climb on in the same manner as the operator, first one knee, then the other.

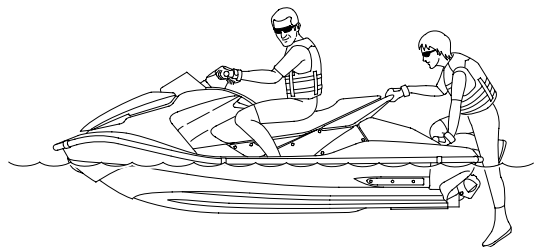

6. Once the passenger is seated, the operator should check that the passenger is holding onto the waist of the operator and have placed both feet on the footboards.
7. The operator is now ready to start the engine.

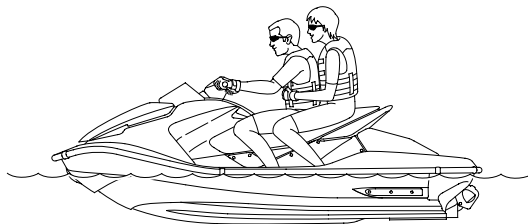

Check your path is clear of other boats, swimmers, or other obstacles in the water.

We recommend use of the limit mode until the PWC operator is familiar with operating the PWC.

Get familiar with operating the throttle. To go faster, pull the throttle lever toward you. To go slower, reduce pressure on the lever to allow it to move away from you. Gradually increase throttle to see how speed affects your directional control, then try varying the speed.

Try turning gradually. Pay attention to the connection between throttle input and the use of the handlebar. Remember, steering with the handlebar will not turn the PWC unless you are applying some throttle.

Get acquainted with the handling of your PWC.

Turning

Turning your PWC requires two actions:

- Turning the handlebar (in the direction you want to go).
- Using the throttle lever (to maintain thrust).

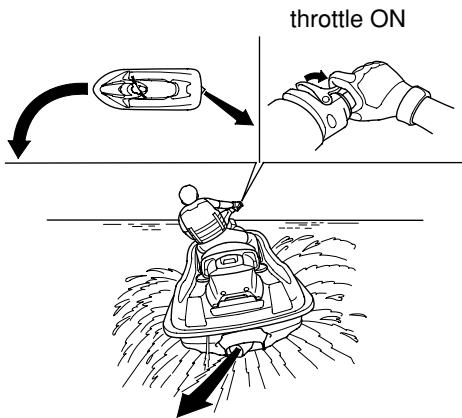

Your PWC will not turn if you are not applying some throttle. Jet thrust is necessary to change your direction.

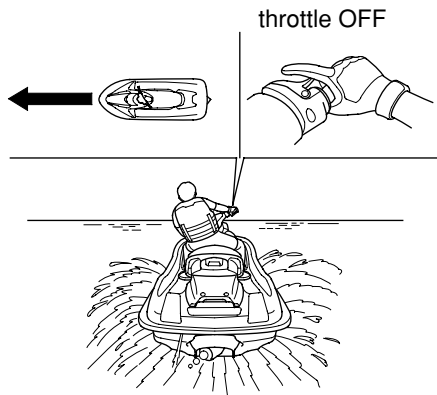

Before turning, always check to make sure you aren't turning into another PWC's path.

Your PWC requires thrust to turn, so you must pull on the throttle lever while you turn the handlebar. The more you pull on the throttle lever, the more thrust your PWC will have and the sharper your turns will be. If you pull the trim lever, the bow will lower and your PWC will turn more easily.

To turn at higher speeds, you should first reduce speed by gently releasing the throttle a little. Too sharp a turn at high speed may cause the PWC to slide sideways or spin and throw off the operator and passenger.

If you are heading toward an obstacle you want to avoid — do not release the throttle lever. Keep the throttle on and steer away from the object.

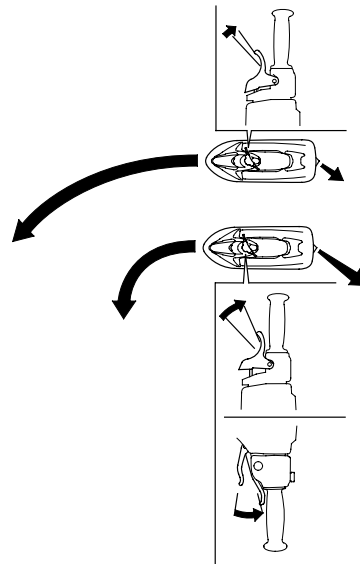

Turning

Off-Throttle Steering (OTS)

Your PWC is equipped with an Off-Throttle Steering (OTS) system.

At cruising speeds and faster, your PWC's OTS will activate if you let go of the throttle and turn the handlebar all the way to the left or right. OTS will provide some turning thrust but you can turn sharper if you apply the throttle. OTS does not work when the engine is off.

For the best steering and turning performance, apply throttle while turning the handlebar.

Reverse Operation

Before selecting reverse, look around and behind you, and slow your PWC to idle speed.

⚠ WARNING

Shifting to reverse at higher forward speeds may cause abrupt deceleration. You and your passenger could be thrown forward or off of the personal watercraft and be seriously injured.

Shift to reverse only while the engine is idling or off.

Reverse Operation

1. Squeeze the trigger and pull the reverse lever toward you. This drops the reverse bucket over the jet pump steering nozzle, diverting the thrust forward to push the PWC backward (page 45).
2. Turn the handlebar opposite the direction you want. (To steer the rear of your PWC to the left, turn the handlebar to the right. To steer to the right, turn the handlebar to the left.)
3. Carefully apply throttle to maintain control.
4. To return to normal operation, release throttle pressure, wait for your PWC to slow to idle speed, then push the lever forward.

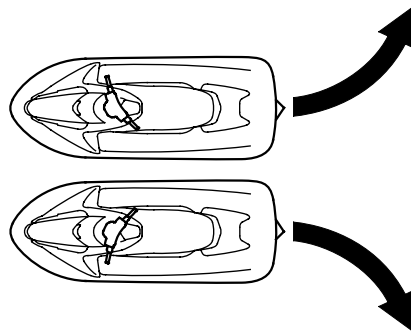

Stopping/Docking/Beaching

Your PWC has no brakes. Please keep this in mind whenever you are planning to stop.

The drag of the water will slow it to a stop after the throttle is closed. Running at full speed, your PWC may require up to 130 yards (120 m) to stop after the throttle is released.

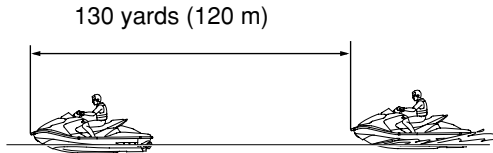

Stopping/Docking/Beaching

Stop your PWC

- Check that there are no other boats, swimmers, or obstacles in your path.
- Slow the PWC by releasing the throttle lever as you approach the stopping area.

NOTICE

Starting or stopping the engine in less than three feet of water can damage the jet pump if debris or weeds are drawn in.

Dock your PWC

- With the engine idling, ride to the stopping area. Keep your engine running so you have jet thrust to maneuver. Open the throttle slightly in case you need power to steer away from an obstacle.

You and your passenger should keep all feet, arms, and hands inside the PWC as it approaches a dock or another object in the water.

- Push the engine stop button or pull the lock clip and moor your PWC to the dock securely.

Do not run your PWC onto a beach with the engine running. Sand or other debris can enter the jet pump and the hull may be damaged. Stop the engine with at least three feet of water under the hull.

Beach your PWC

- Get off your PWC, guide it in, and pull it up on the beach.

Riding with a Passenger or Cargo

Your PWC is designed to carry you and one passenger. Whenever you add a passenger or cargo, you must be careful not to exceed the total load limits (*Load Limits*, page 61). Make sure your cargo is properly secured (*Loading Guidelines*, page 62).

Be aware that carrying a passenger or heavy cargo can affect acceleration, slowing, and handling.

Do not carry a passenger until you become comfortable operating your PWC by yourself.

For a smoother ride with a passenger, lock the trim lever.

Remember, you are responsible for the safety of your passenger. Be sure they are wearing PFDs and other protective apparel (page 52), and are familiar with all safety information.

Avoid giving a ride to a passenger whose feet do not reach the footboards.

Riding with a Passenger or Cargo

Tell your passenger to hold on firmly to your waist, lean with you in the turns, and keep both feet on the footboards at all times, even when the PWC is stopped and idling. The operator should let the passenger know if a sudden maneuver is planned.

WARNING

If a passenger falls off the back of a personal watercraft after the operator opens the throttle, water can be forced into lower body cavities, causing severe internal injuries.

- Do not start the engine until the passenger is seated properly and holding on.
- All riders should wear a wet suit bottom or equivalent.

Post-ride Maintenance

After you finish riding your PWC, always perform post-ride maintenance to keep your PWC in good operating condition.

1. Remove your PWC from the water.
2. Purge the exhaust system of excess water by starting the engine and, while checking the tachometer, repeatedly rev the engine up to no more than 4,000 rpm for less than 15 seconds.
 - Engine rpm can increase rapidly when the watercraft is out of water.

NOTICE

Operating the engine out of water at high rpm or for longer than 15 seconds at a time may cause severe engine and/or exhaust system damage.

3. Wash the hull, deck, handlebar, and intake/propulsion system with fresh water.
4. Flush the cooling system with fresh water (page 154).
5. Remove the lock clip from the engine stop button/switch.

(cont'd)

Post-ride Maintenance

6. Use fresh water to rinse out the engine compartment. Avoid spraying water on the electrical components.

NOTICE

High pressure water (or air) can damage certain parts of your personal watercraft.

7. Remove the bilge drain plugs to drain any water. Raise the bow (front) of your PWC about 1 foot to allow complete draining.
8. Wipe the engine compartment dry with dry, clean rags.
9. Confirm the engine and the exhaust system is cool, then spray a water-displacement corrosion-proof lubricant (without Teflon or molybdenum additives, such as CRC 6-56 or equivalent) on the engine, electrical wiring and jet pump assembly.

If you won't be riding for more than one week, perform the following:

- Spray a water-displacement corrosion-proof lubricant (without Teflon or molybdenum additives, such as CRC 6-56 or an equivalent) into the throttle body (pages 139-140).
 - ARX1200T2 only: Spray a water-displacement corrosion-proof lubricant (without Teflon or molybdenum additives such as CRC 6-56 or equivalent) on the outside of the turbocharger (especially the wastegate link) (page 144).
10. Keep your PWC as level as possible and place a cover over it for storage. For prolonged storage, refer to *Storing Your Honda* on page 170.

To help keep your PWC in good shape, this section includes a Maintenance Schedule for required service, a list of periodic checks you should perform at least once a month, and step-by-step instructions for specific maintenance tasks.

You'll also find important safety precautions, information on fuels and oils, and tips for keeping your Honda looking great.

For information about the exhaust emission requirements of the U.S. Environmental Protection Agency (EPA) and the California Air Resources Board (CARB), see page 210.

For information about replacing fuses, see page 188.

Maintenance, replacement, or repair of emission control devices and systems may be performed by any engine repair establishment or individual, using parts that are “certified” to EPA standards.

Before You Service Your Honda

The Importance of Maintenance	102
Maintenance Safety	103
Important Safety Precautions	104
Maintenance Schedule	105
Maintenance Record	109

(cont'd)

Servicing Your Honda

Service Preparations

Component Locations	110
Rear Cover Removal	113
Rear Tray Removal	114
Tool Kit	115
Owner's Manual Storage	116
Seat Removal	117

Service Procedures

Fluids, Filters & Lubricants

Fuel	119
Engine Oil & Filter	122
Air Filter	135
Lubrication	138

Engine

Throttle	145
Engine Idle Speed	148
Spark Plugs	149
Engine Cooling System	153

Hull

Bilge Drain System	157
--------------------------	-----

Steering & Propulsion System

Off-throttle Steering System	159
------------------------------------	-----

Electrical

Battery	161
---------------	-----

Appearance Care	166
-----------------------	-----

Servicing Your Honda

The following table summarizes the three types of inspections and servicing recommendations for your PWC. Both the pre-ride inspection and the scheduled maintenance at the recommended intervals are necessary to assure safe and dependable performance.

Type of Inspection/Service	Refer to page :	When Performed	Who Performs
Pre-ride Inspection	56	before every ride	you
Post-ride Maintenance	97	after every ride	you
Maintenance Schedule	105	interval on schedule	your Honda PWC dealer*

* unless you have the proper tools and service data and are mechanically qualified

The Importance of Maintenance

Keeping your PWC well-maintained is absolutely essential to your safety. It's also a good way to protect your investment, get maximum performance, avoid breakdowns, and have more fun. A properly maintained PWC will also help to reduce air and water pollution.

Remember, proper maintenance is the owner's responsibility. Be sure to inspect your PWC before each ride, service it after every ride, and follow the Maintenance Schedule in this section.

WARNING

Improperly maintaining this personal watercraft or failing to correct a problem before you ride can cause a crash in which you can be seriously hurt or killed.

Always follow the inspection and maintenance recommendations and schedules in this owner's manual.

If your PWC submerges or is involved in a crash, be sure your Honda PWC dealer inspects all major parts, even if you are able to make some repairs.

This section includes instructions on how to perform some important maintenance tasks. If you have basic mechanical skills, you can perform many of these tasks with the tools provided with your PWC.

Other tasks that are more difficult and require special tools are best performed by professionals.

Some of the most important safety precautions follow. However, we cannot warn you of every conceivable hazard that can arise in performing maintenance. Only you can decide whether or not you should perform a given task.

WARNING

Failure to properly follow maintenance instructions and precautions can cause you to be seriously hurt or killed.

Always follow the procedures and precautions in this owner's manual.

Maintenance Safety

Important Safety Precautions

- Make sure the engine is off and the lock clip is removed from the engine stop button/switch before you begin any maintenance or repairs. This will help eliminate several potential hazards:

Carbon monoxide poisoning from engine exhaust. Be sure there is adequate ventilation whenever you operate the engine.

Burns from hot personal watercraft parts. Let the engine and exhaust system cool before touching.

Injury from moving parts. Do not run the engine unless instructed to do so.

- Read the instructions before you begin, and make sure you have the tools and skills required.
- To support your PWC, place it on an appropriate stand or trailer.
- To reduce the possibility of a fire or explosion, be careful when working around gasoline. Use only non-flammable solvent, not gasoline, to clean parts. Keep cigarettes, sparks, and flames away from all fuel-related parts.

Remember that your Honda PWC dealer knows your PWC best and is fully equipped to maintain and repair it. To ensure the best quality and reliability, use only new genuine Honda parts or their equivalents for repair and replacement. If you have the tools and skills required for additional maintenance jobs, you can purchase an official Honda Service Manual (page 220).

Maintenance Schedule

The required Maintenance Schedule that follows specifies how often you should have your PWC serviced, and what things need attention. It is essential to have your PWC serviced as scheduled to maintain safe, dependable performance and proper emission control.

The service intervals in this Maintenance Schedule are based on average riding conditions. Some items will need more frequent service if you ride in salt water or at full throttle. Consult your Honda PWC dealer for recommendations applicable to your individual needs and use.

Some items in the Maintenance Schedule can be performed with basic mechanical skills and hand tools. Procedures for these items are provided in this manual. Other items involve more extensive procedures and may require special training, tools, and equipment. We recommend that you have your Honda PWC dealer perform these tasks unless you have advanced mechanical skills and the required tools and equipment. Procedures for such items in this schedule are provided in an official Honda Service Manual available for purchase (page 220).

(cont'd)

Maintenance Schedule

If you do not feel capable of performing a given task or need assistance, remember that your Honda PWC dealer knows your PWC best and is fully equipped to maintain and repair it. If you decide to do your own maintenance, use only genuine Honda parts or their equivalents for repair or replacement to ensure the best quality and reliability.

Perform the pre-ride inspection (page 56) and owner maintenance (page 107) at each scheduled maintenance period.

Each item on the maintenance schedule requires some mechanical knowledge. Certain items (particularly those marked * and **) may require more technical information and tools. Consult your Honda PWC dealer.

- * Should be serviced by your Honda PWC dealer, unless you have the proper tools and service data and are mechanically qualified. Refer to the official Honda Service Manual (page 220).
- ** In the interest of safety, we recommend these items be serviced only by your Honda PWC dealer.

Maintenance Schedule

		FREQUENCY		WHICHEVER COMES FIRST	INITIAL MAINTENANCE	REGULAR MAINTENANCE INTERVAL		Refer to page
				MONTH	—	6	12	
				HOURS	10	100	200	
EMISSION RELATED ITEMS	*	FUEL TANK/FUEL LINE	Inspect			○	○	—
	*	THROTTLE CABLE	Inspect/Lubricate			○	○	—
		THROTTLE BODY	Inspect/Lubricate		○	○	○	139-140
		SPARK PLUGS	Inspect/Replace				○	149
	**	VALVE CLEARANCE	Inspect/Adjust		EVERY 200 hours			—
		AIR FILTER	Replace				○	134
		ENGINE OIL	Replace		EVERY 50 hours or every year			122
		ENGINE OIL FILTER	Replace				○	129
	*	ENGINE IDLE SPEED	Adjust		○	○	○	148
		COOLING SYSTEM	Inspect		○	○	○	153

* Should be serviced by your Honda PWC dealer, unless you have the proper tools and service data and are mechanically qualified. Refer to the official Honda Service Manual (page 220).

** In the interest of safety, we recommend these items be serviced only by your Honda PWC dealer.

NOTE: • Some items will need more frequent service if you ride in salt water or at full throttle. Consult your Honda PWC dealer for recommendations applicable to your individual needs and use.

(cont'd)

Maintenance Schedule

	ITEMS	FREQUENCY		WHICHEVER COMES FIRST	INITIAL MAINTENANCE	REGULAR MAINTENANCE INTERVAL		Refer to page
				MONTH	—	6	12	
				HOURS	10	100	200	
NON-EMISSION RELATED ITEMS	* IMPELLER	Inspect				○	○	—
	COUPLING RUBBER	Inspect			○	○	○	—
	TURBO	Lubricate		ARX1200T2	○	○	○	144
	* ANODE	Turbo	Inspect/Replace	ARX1200T2			○	—
		Exhaust Manifold, Oil Cooler and Cylinder Head	Inspect/Replace			EVERY 400 hours		—
		BILGE STRAINER	Clean			○	○	157
		DRAIN PLUG	Inspect/Replace				○	157
	** BEARING HOUSING	Grease/Inspection				○	○	—
	* TRIM SYSTEM	Inspect/Adjust/Lubricate			○	○	○	—
	* REVERSE SYSTEM	Inspect/Adjust/Lubricate				○	○	—
* NUTS, BOLTS, FASTENERS	Inspect			○	○	○	—	
* STEERING SYSTEM	Inspect/Adjust/Lubricate			○	○	○	—	

- * Should be serviced by your Honda PWC dealer, unless you have the proper tools and service data and are mechanically qualified. Refer to the official Honda Service Manual (page 220).
- ** In the interest of safety, we recommend these items be serviced only by your Honda PWC dealer.

NOTE: • Some items will need more frequent service if you ride in salt water or at full throttle. Consult your Honda PWC dealer for recommendations applicable to your individual needs and use.

Maintenance Record

Keeping an accurate maintenance record will help ensure that your PWC is properly maintained. Retain detailed receipts to verify the maintenance was performed. If the personal watercraft is sold, these receipts should be transferred with the personal watercraft to the new owner.

Make sure whoever performs the maintenance completes this record. All scheduled maintenance, including the 10 hours initial maintenance, is considered a normal owner operating cost and will be charged for by your dealer. Use the space under Notes to record anything you want to remind yourself about or mention to your dealer.

Hours or Months	Hourmeter	Date	Performed By:	Notes
100 or 6				
200 or 12				
300 or 18				
400 or 24				
500 or 30				
600 or 36				
700 or 42				
800 or 48				
900 or 54				
1000 or 60				

Component Locations

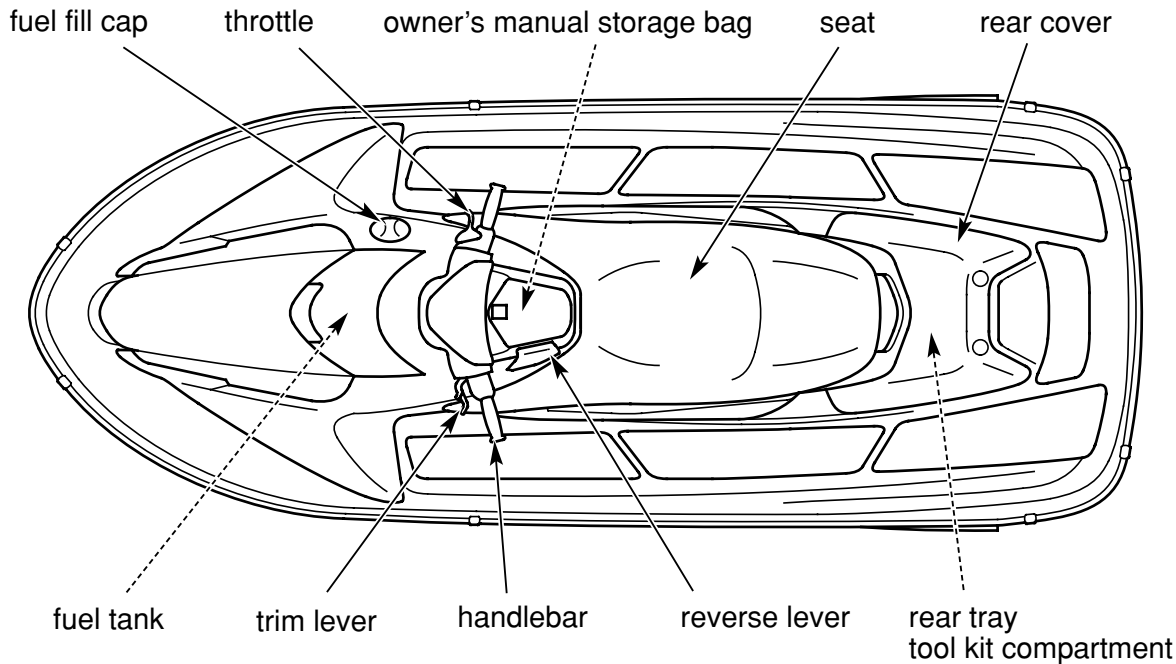

Component Locations

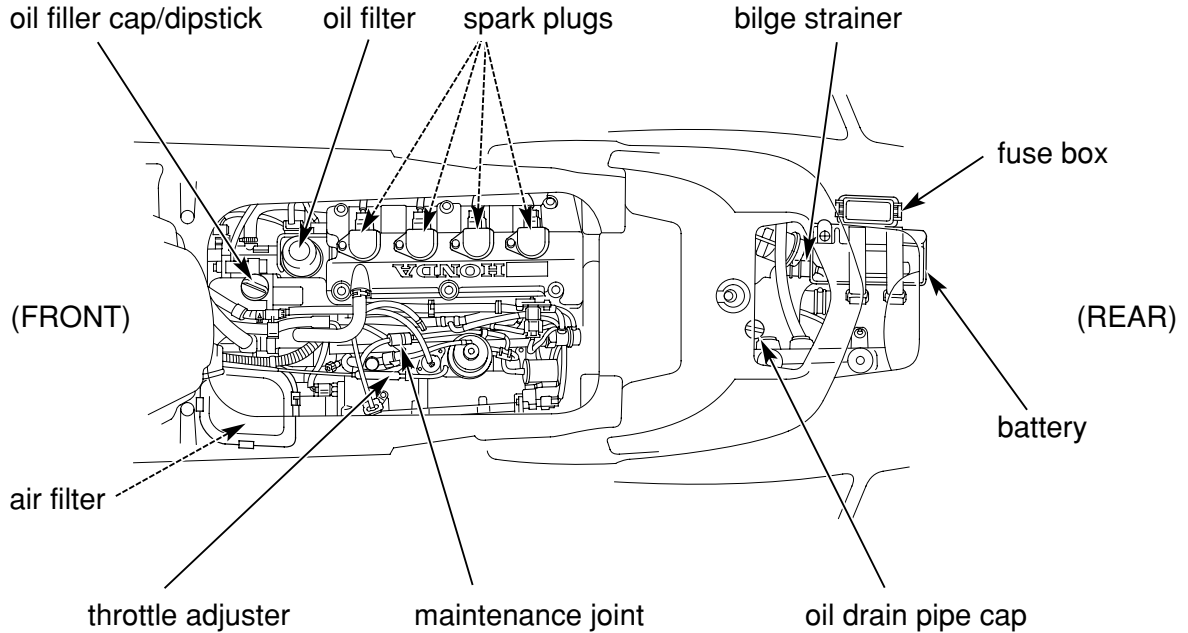

(cont'd)

Component Locations

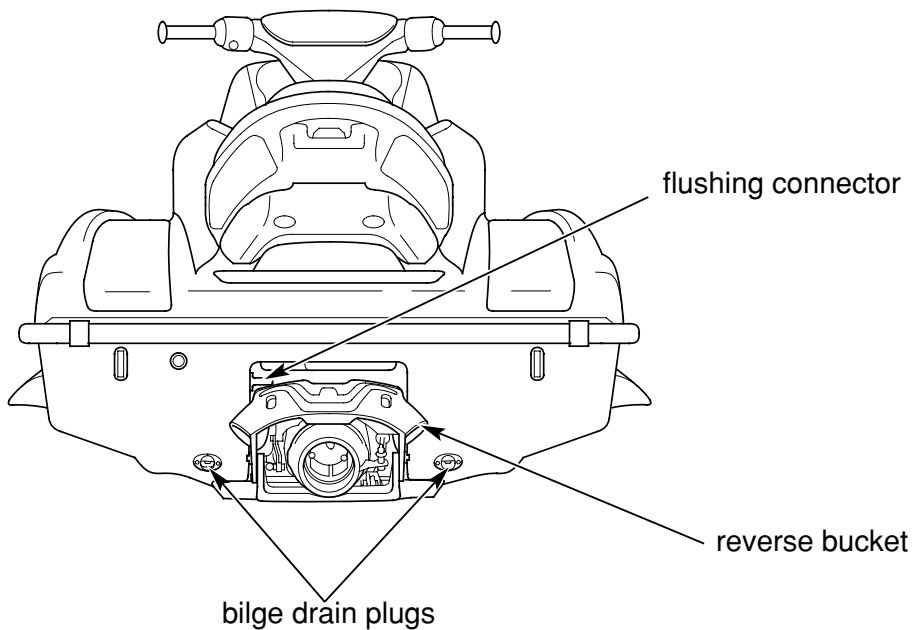

Rear Cover Removal

Refer to *Safety Precautions* on page 104.

The rear cover must be removed for battery, fuse, and engine maintenance, and for access to the tool kit.

Removal

1. Remove the seat (page 117).
2. Turn the knobs (1) to OPEN position and remove the rear cover (2).

Installation

Install the rear cover and turn the knobs to CLOSE position.
Make sure the rear cover is installed securely.

REAR

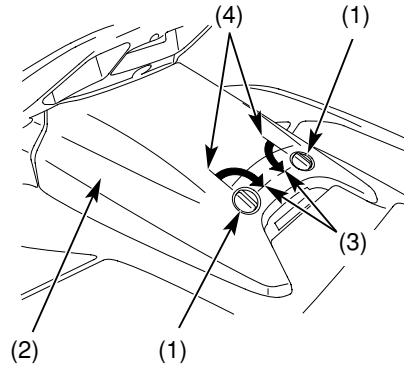

- (1) knobs (3) OPEN position
(2) rear cover (4) CLOSE position

Rear Tray Removal

Refer to *Safety Precautions* on page 104.

The rear tray must be removed for battery, fuse, and engine maintenance.

Removal

1. Remove the seat (page 117) and the rear cover (page 113).
2. Pull the knob (1) and remove the rear tray (2).

Installation

1. Pull the knob, install the rear tray, and release the knob.
2. Push the knob until it locks.
3. Make sure the rear tray securely latched.

NOTICE

Install the rear tray securely, or water may enter the compartment and possibly cause severe engine damage.

UNDER REAR COVER

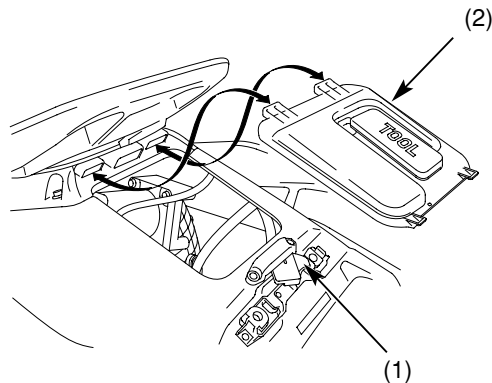

- (1) knob
(2) rear tray

The tool kit is stored under the rear cover (page 113). Some basic repairs, minor adjustments, and parts replacement can be performed with the tools contained in the kit.

UNDER REAR COVER

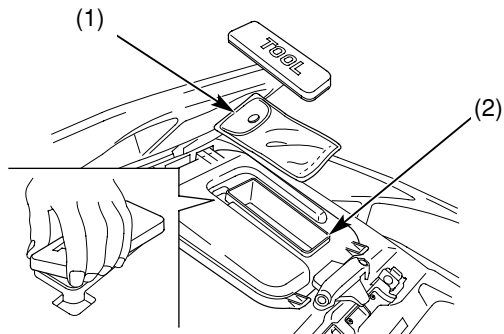

(1) tool kit

(2) tool kit compartment

- 10 x 12 mm open end wrench
- 14 x 17 mm open end wrench
- 10 x 12 mm box end wrench
- 4 mm hex wrench
- 5 mm hex wrench
- Standard/Phillips screwdriver
- screwdriver handle
- pliers
- spark plug wrench
- tool bag
- water resistant bag

Owner's Manual Storage

Your PWC provides storage for the owner's manual so you'll have it with you for easy reference. To avoid possible water damage, store your owner's manual (and other documents) in the plastic storage bag (1) in the glove box (2) (page 63).

Be careful not to flood this area when washing your PWC.

FRONT

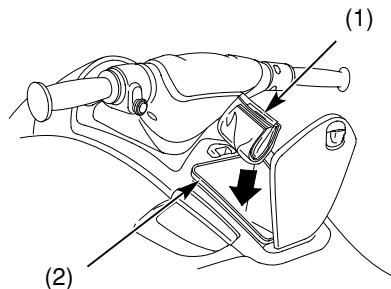

- (1) owner's manual storage bag
- (2) glove box

Seat Removal

Refer to *Safety Precautions* on page 104.

The seat must be removed for engine maintenance.

Removal

1. Release the seat latch (1).
2. Pull the seat (2) back and up.

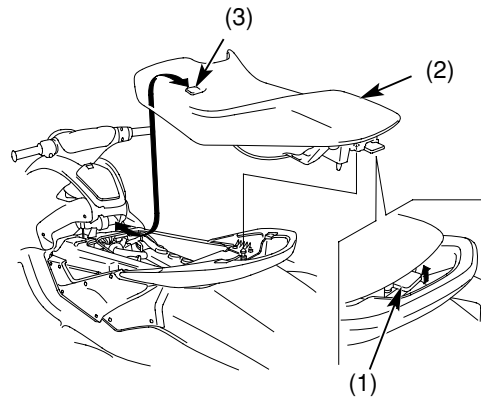

- (1) seat latch (3) seat prong
(2) seat

(cont'd)

Seat Removal

Place the removed seat as shown in following illustration.

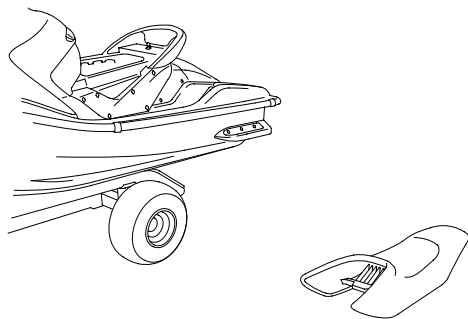

Installation

1. Position the seat prong (3) and press on the seat until the latch closes.
2. Make sure to tighten the latch securely.

Refer to *Safety Precautions* on page 104.

Fuel Recommendation

Type	premium unleaded
Pump Octane Number	91 (or higher)

This marine engine is certified to operate on premium unleaded gasoline. Unleaded gasoline produces fewer engine and spark plug deposits and extends exhaust system life.

Your engine is designed to use premium gasoline that has a pump octane number of 91 or higher. Gasoline pumps at service stations normally display the pump octane number.

If you are unable to find premium unleaded gasoline, you may substitute an unleaded regular gasoline (minimum unleaded gasoline 86 pump octane or higher). However, keep the engine under 5,000 rpm, and substitute to unleaded premium gasoline as soon as possible.

For information on the use of oxygenated fuels, see page 216.

Never use stale or contaminated gasoline. Avoid getting dirt, dust, or water in the fuel tank.

Fuel

Fuel Capacity

Fuel tank capacity:
16.64 US gal (63.0 ℓ)

The tank should be refilled as soon as possible after the low fuel indicator and WARNING lamp flash and the beeper sounds.

Refueling Procedure

Refer to *Safety Precautions* on page 104.

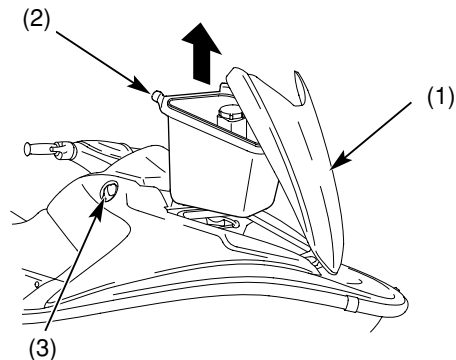

(1) front hood (3) fuel fill cap
(2) front storage box

1. Pull the front hood latch and lift the front hood (1).

2. Remove the front storage box (2).
3. Turn the fuel fill cap (3) counterclockwise to remove it.
4. Add fuel until you see the level reach the filler tube neck (4).
5. Stop refueling when fuel comes through the hole (5) in the filler neck.

⚠ WARNING

Gasoline is highly flammable and explosive. You can be burned or seriously injured when handling fuel.

- Stop the engine and keep heat, sparks and flame away.
- Handle fuel only outdoors.
- Wipe up spills immediately.

6. After refueling, install the fuel fill cap and turn it clockwise until it clicks.
7. Reinstall the front storage box and close the front hood, then check the latch is secure.

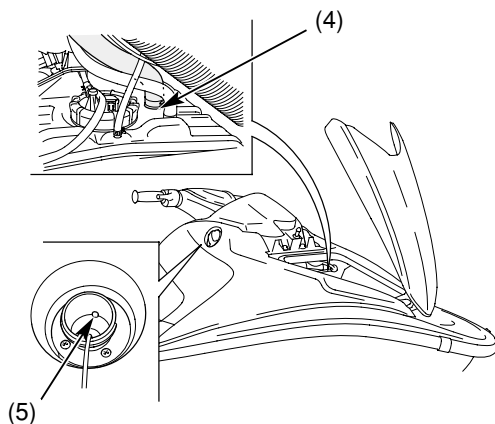

(4) filler tube neck (5) hole

Engine Oil & Filter

This model is equipped with a dry sump engine.

Do not leave the engine stopped for several hours before you check the oil level in the oil tank.

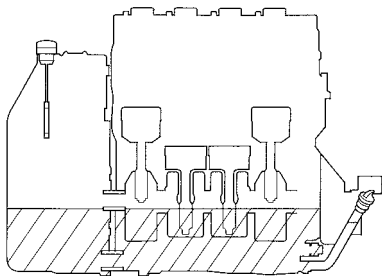

The oil in the oil tank moves toward the engine body (crankcase).

The engine must be warmed-up (page 127) and then turned off to get a correct reading of the oil level.

The dry sump engine oil returns from the oil tank side to the engine body side through the gap between the oil pump rotor and shaft. Therefore, the oil level in the oil tank does not lower immediately after warming up and stopping the engine.

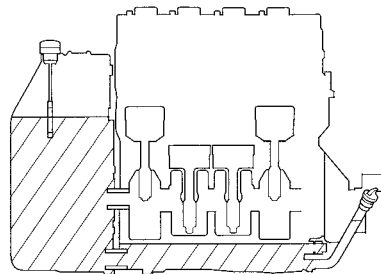

Oil level with the engine stopped right after warming up.

Engine Oil & Filter

Engine oil quality is a major factor that affects both the performance and the service life of the engine.

Using the proper oil (page 124) and filter, and regularly checking, adding, and changing oil will help extend your engine's life. Even the best oil wears out. Changing oil helps get rid of dirt and deposits in the engine. Operating the engine with old or dirty oil can damage your engine. Running the engine with insufficient oil can cause serious damage to the engine.

Change the engine oil as specified in the maintenance schedule on page 107.

Engine Oil & Filter

Oil Recommendation

API classification	SG or higher except oils labeled as energy conserving on the API service label.
viscosity (weight)	SAE 10W-40
JASO T 903 standard	MA or MB
suggested oil*	Pro Honda GN4, HP4 (without molybdenum additives), or HP4M (with molybdenum additives) 4-stroke oil, or an equivalent motorcycle oil.

*Suggested oils are equal in performance to SJ oils that are not labeled as energy conserving on the circular API service label.

- Your PWC does not need oil additives. Use the recommended oil.
- Do not use non-detergent, vegetable, or castor based racing oils.
- Do not use API SH or higher oils labeled as energy conserving on the API service label.

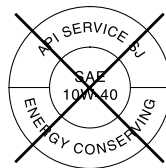

NOT RECOMMENDED

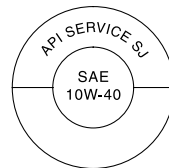

OK

Engine Oil & Filter

Other viscosities shown in the following chart may be used when the average temperature in your riding area is within the indicated range.

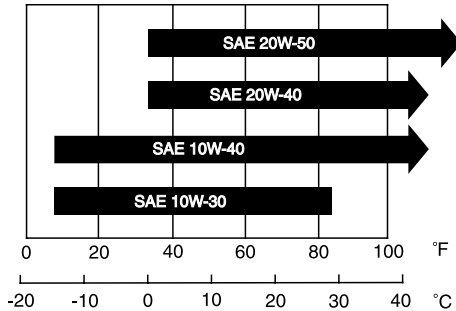

JASO T 903 Standard

JASO T 903 is the standard for classification of engine oils 4-stroke engines used in motorcycles.

There are two classes: MA and MB. Oil conforming to the standard has the following classification on the oil container.

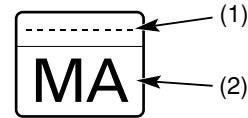

PRODUCT MEETING JASO T 903
COMPANY GUARANTEEING THIS MA PERFORMANCE:

PRODUCT MEETING JASO T 903
COMPANY GUARANTEEING THIS MA PERFORMANCE:

- (1) code number of the sales company of the oil
- (2) indication of classification of oil

Engine Oil & Filter

Checking & Adding Oil

Refer to *Safety Precautions* on page 104.

Check the engine oil level each day before operating your PWC and add oil if needed. Keep your PWC as level as possible for this procedure.

It is preferable to check the oil on shore. If necessary, this procedure may be performed with your PWC on calm water.

Before checking the engine oil level:

Perform this pre-check procedure on shore.

1. Remove the seat (page 117), rear cover (page 113), and the rear tray (page 114).
2. Remove the oil filler cap/dipstick (1) and wipe it clean.
3. Insert the oil filler cap/dipstick until it seats, but do not screw it in.

ENGINE COMPARTMENT

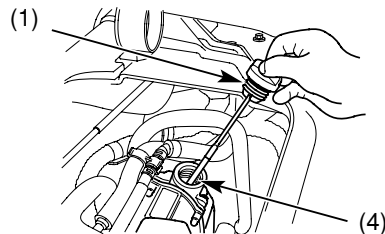

(1) oil filler cap/dipstick (4) oil filler cap hole

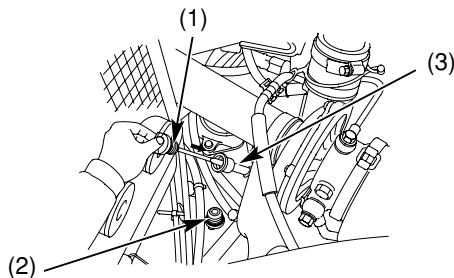

(2) oil drain pipe cap (3) oil drain pipe

Engine Oil & Filter

4. Remove the oil filler cap/dipstick and check the oil level.
 - If oil appears on the oil filler cap/dipstick, refer to *To check the oil level*.
 - If oil does not appear, perform step 5.
5. Remove the oil drain pipe cap (2) and insert the oil filler cap/dipstick in the oil drain pipe (3) until it seats, but don't screw it in.
6. Remove the oil filler cap/dipstick, if no oil appears on the dipstick, do not start the engine.
7. Reinstall the oil drain pipe cap and tighten it securely.

Before starting the engine, add the specified oil into the filler cap hole (4), until it appears on the oil filler cap/dipstick.
8. Reinstall the oil filler cap/dipstick. Make sure the cap is tightened securely.
9. Install the rear tray, rear cover and seat.

To check the oil level on shore

1. In a well-ventilated area, start the engine while flushing the cooling system (page 154).

NOTICE

- *Start the engine before turning on the water to prevent flow through the exhaust pipe back into the engine where it could cause severe damage.*
 - *Avoid running the engine without water flow for more than 15 seconds to prevent severe engine and exhaust system damage.*
2. Let the engine idle for 5 minutes. If the air temperature is below 10°C (50°F), let it idle for an additional 5 minutes (a total of 10 minutes).

(cont'd)

Engine Oil & Filter

3. Stop the flushing.

NOTICE

Avoid running the engine without water flow for more than 15 seconds to prevent severe engine and exhaust system damage.

4. Stop the engine and wait a few minutes.

5. Remove the seat (page 117).

This procedure continues with Step 6 on page 129.

To check the oil level on calm water

1. Start the engine.
2. Warm up the engine at approximately 4,000 rpm for 5 minutes.
If the air temperature is below 10°C (50°F), let the engine idle for an additional 5 minutes (a total of 10 minutes).
3. Let the engine idle for a minute.
4. Stop the engine and get off your PWC.
5. Remove the seat (page 117).

Engine Oil & Filter

6. Remove the oil filler cap/dipstick (5) and wipe it clean.
7. Insert the oil filler cap/dipstick until it seats, but don't screw it in.
8. Remove the oil filler cap/dipstick (5) and check the oil level.
 - If the oil is at or near the upper level mark (6) – you do not have to add oil.
 - If the oil is below or near the lower level mark (7) – remove the oil filler cap/dipstick (5) and add the recommended oil until it reaches the upper level mark. (Do not overfill.)Wipe up any spilled oil immediately.
9. Reinstall the oil filler cap/dipstick.
10. Check for oil leaks.
11. Install the seat.

ENGINE COMPARTMENT

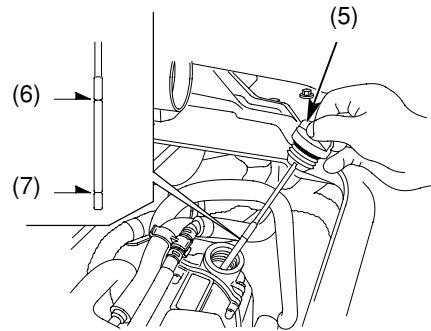

- (5) oil filler cap/dipstick
(6) upper level mark
(7) lower level mark

Engine Oil & Filter

Changing Engine Oil & Filter

Refer to *Safety Precautions* on page 104.

Your PWC's oil filter has very specific performance requirements. Use a new genuine Honda oil filter or a filter of equal quality specified for your model.

NOTICE

Using the wrong oil filter may result in leaks or premature engine damage.

This procedure requires mechanical skill and professional tools such as a torque wrench and oil filter wrench, as well as a means for disposing of the drained fluid (page 178). If you do not have the skills or the tools, see your Honda PWC dealer.

Engine Oil & Filter

Wipe up any spilled oil immediately.

Drain the Engine Oil:

1. Secure your PWC on a stand or trailer.
2. Remove the seat (page 117), rear cover (page 113) and rear tray (page 114).
3. Remove the oil filler cap/dipstick (1) and the oil drain pipe cap (2).
4. Using a commercially-available fluid evacuator, drain the oil from the oil filler cap hole (3) and the oil drain pipe (4).

ENGINE COMPARTMENT

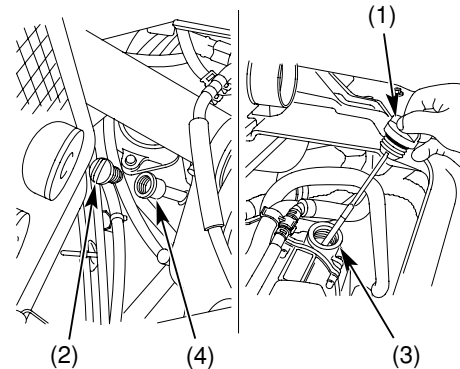

(1) oil filler cap/dipstick
(2) oil drain pipe cap

(3) oil filler cap hole
(4) oil drain pipe

(cont'd)

Engine Oil & Filter

Install a New Oil Filter:

5. To avoid spilling the oil, wrap a soft cloth around the oil filter.
6. Remove the oil filter (5) with a filter wrench and let the remaining oil drain into a suitable container. Discard the oil filter in an approved manner (page 178).
7. Pour the drained oil into a suitable container and dispose of it in an approved manner (page 178).

NOTICE

Improper disposal of drained fluids is harmful to the environment.

ENGINE COMPARTMENT

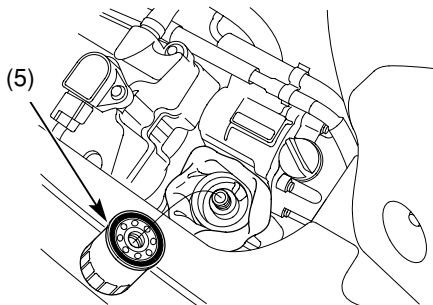

(5) oil filter

8. Apply a thin coat of engine oil to the rubber seal (6) of a new oil filter.

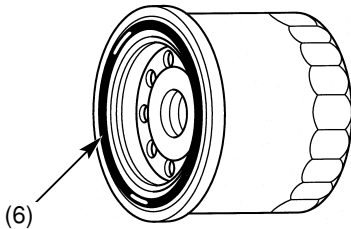

(6) oil filter rubber seal

9. Install the new oil filter and tighten it by hand.
10. Using an oil filter wrench attachment and a torque wrench, tighten the new oil filter to the specified torque:
20 lbf·ft (26 N·m, 2.7 kgf·m)

11. Install the oil drain pipe cap.

Add Engine Oil:

12. Fill the oil tank with the recommended oil slowly (page 124).

If the oil filter was replaced, use approximately:

- ARX1200T2
4.5 US qt (4.3 ℓ)
- ARX1200N2
4.3 US qt (4.1 ℓ)

If the oil filter was not replaced, use approximately:

- ARX1200T2
4.4 US qt (4.2 ℓ)
- ARX1200N2
4.2 US qt (4.0 ℓ)

(cont'd)

Engine Oil & Filter

13. Install the oil filler cap/dipstick securely.
14. Start the engine and let it idle for a few minutes while flushing the cooling system.

NOTICE

Turning on the water before starting the engine will allow water to flow through the exhaust pipe back into the engine where it could cause severe damage.

15. Stop the flushing.

NOTICE

Running the engine without water flow for more than 15 seconds can cause severe engine and exhaust system damage.

16. Stop the engine.
17. Check that the oil level is at the upper level mark on the oil filler cap/dipstick (page 128).
18. Check that there are no oil leaks.
19. Install the rear tray, rear cover and seat.

Refer to *Safety Precautions* on page 104.

Service the air filter more frequently if you ride in salt water or at full throttle. Your Honda PWC dealer can help you determine the correct service interval for your riding conditions.

Your PWC's air filter has very specific performance requirements. Use a new genuine Honda air filter specified for your model or an air filter of equivalent quality.

NOTICE

Using the wrong air filter may result in premature engine damage.

Proper air filter maintenance can prevent premature engine wear or damage, expensive repairs, low engine power, poor gas mileage, and spark plug fouling.

NOTICE

Improper or lack of proper air filter maintenance can cause poor performance and premature engine wear.

Air Filter

Replacement (ARX1200T2)

1. Remove the seat (page 117).
2. Unhook the four springs (1).
3. Remove the air box cover (2).
4. Remove the air filter (3).
5. Discard the air filter.
6. Install a new air filter.
7. Install the removed parts in reverse order of removal.
8. Make sure the air box cover completely latched.

UNDER SEAT

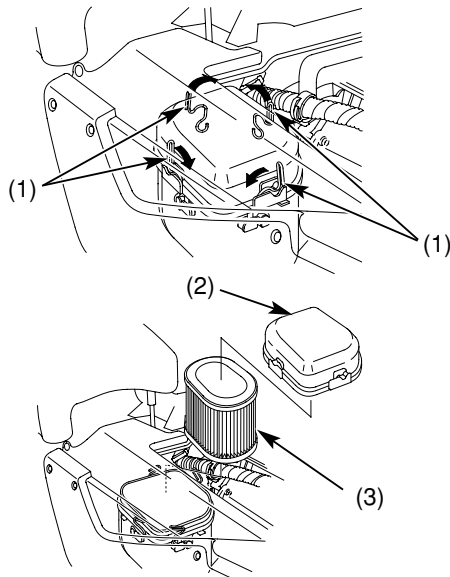

- (1) springs
- (2) air box cover
- (3) air filter

Replacement (ARX1200N2)

1. Remove the seat (page 117).
2. Unhook the four springs (1).
3. Remove the air box cover (2).
4. Remove the air filter (3) by pulling the filter holder rods (4).
5. Discard the air filter.
6. Install a new air filter.
7. Install the removed parts in reverse order of removal.
8. Make sure the air box cover completely latched.

UNDER SEAT

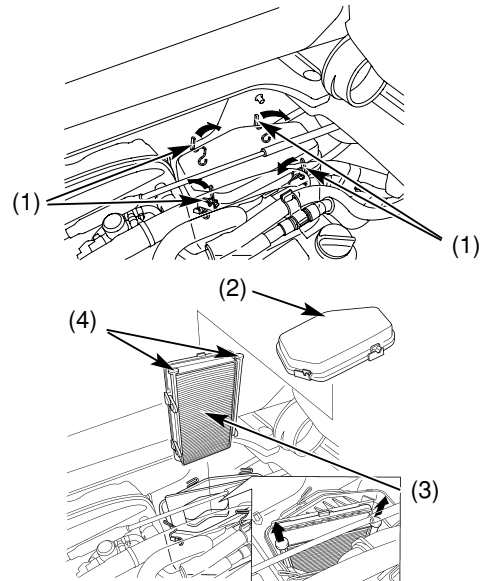

- (1) springs (3) air filter
(2) air box cover (4) filter holder rods

Lubrication

To keep moving parts functioning properly, coat them with a water-displacement corrosion-proof lubricant (without Teflon or molybdenum additives, such as CRC 6-56 or equivalent).

Provide lubrication when moving parts do not work smoothly. Also lubricate as per the maintenance schedule (page 107).

Consult your Honda PWC dealer for more information about lubrication procedures.

Lubrication Points

Lubricate the throttle link, cable and inside of throttle body as shown in following illustrations.

RIGHT HANDLEBAR

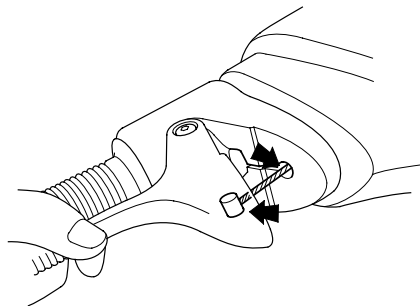

To lubricate and rustproof the inside of the throttle body, proceed as follows after confirming that the engine is stopped and cool.

1. Remove the seat (page 117).

ENGINE COMPARTMENT

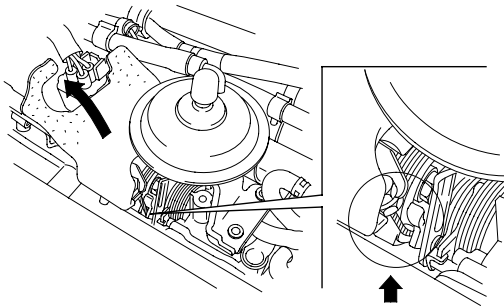

2. Disconnect the maintenance joint (1).

ENGINE COMPARTMENT

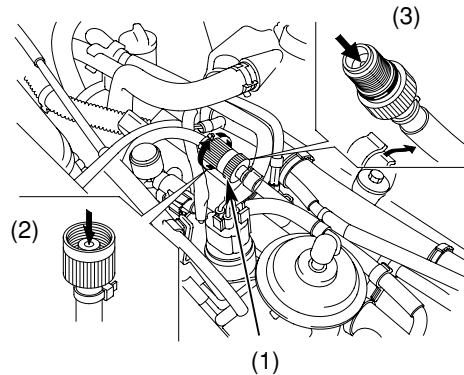

- (1) maintenance joint
- (2) joint hole A
- (3) joint hole B

(cont'd)

Lubrication

3. Insert the spray nozzle of a water-displacement corrosion-proof lubricant (without Teflon or molybdenum additives, such as CRC 6-56 or an equivalent) into joint hole A (2).
4. Open the throttle fully.
5. Spray the lubricant into joint hole A (2) for 3 seconds.
6. Operate the throttle lever slowly, from fully ON to fully OFF, 3 times.
7. Repeat the step 2-6 again.
8. Perform the same lubrication procedure for joint hole B (3).
9. Spray the lubricant to the maintenance joint threads and the O-ring.
10. Reconnect the maintenance joint and make sure it tightened securely.
11. Install the seat.

Lubricate the trim lever link and trim handle cable as shown in the following illustration.

LEFT HANDLEBAR

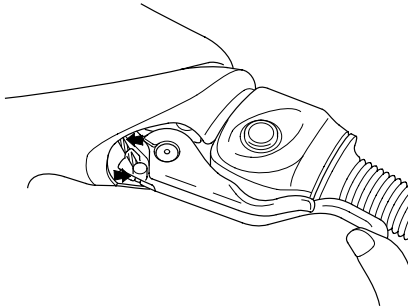

Lubrication

Lubricate the steering cable, cable ball joint, shift cable ball joint, trim cable ball joint and shift guide roller as shown in the following illustrations.

ABOVE FUEL TANK

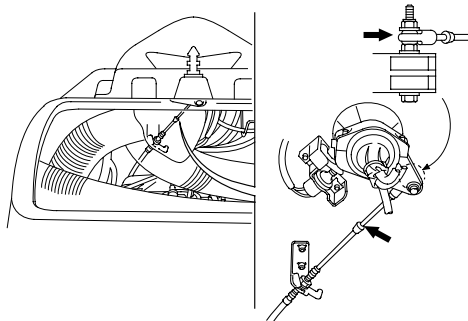

REAR

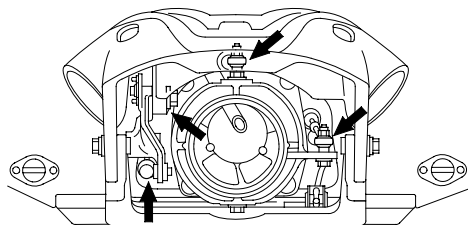

Lubricate the steering pivot shaft as shown in the following illustrations.

- To remove the handle cover, remove the six screws (1) and two clips (2).

HANDLEBAR

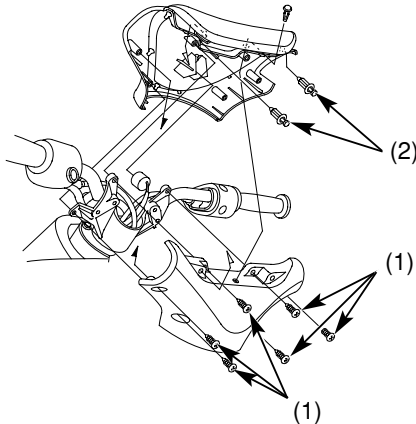

- (1) screws
- (2) clips

PIVOT SHAFT

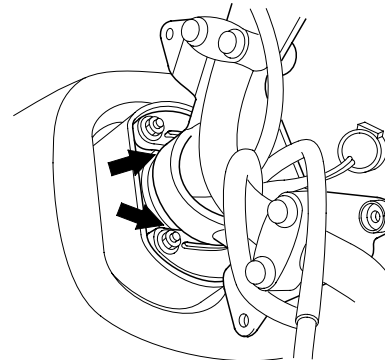

Lubrication

Lubricate the steering nozzle and reverse bucket pivots as shown in the following illustration.

REAR

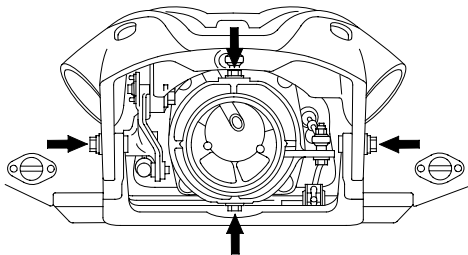

ARX1200T2 only: Lubricate and rustproof the turbocharger (especially the wastegate link) as shown in the following illustration after confirming the engine is cool.

ENGINE COMPARTMENT

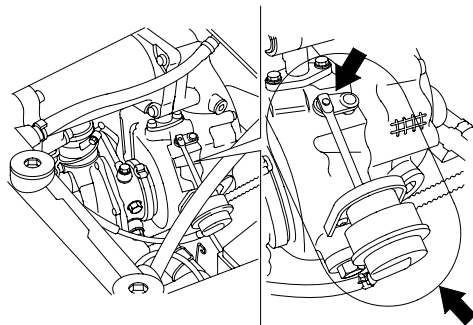

Throttle Freeplay

Refer to *Safety Precautions* on page 104.

RIGHT HANDLEBAR

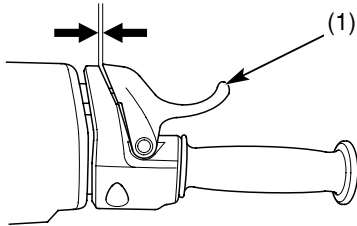

(1) throttle lever

Inspection

Check freeplay at the throttle lever (1).

Freeplay:

1/16–1/4 in (2–6 mm)

If necessary, adjust to the specified range.

Throttle

ENGINE COMPARTMENT

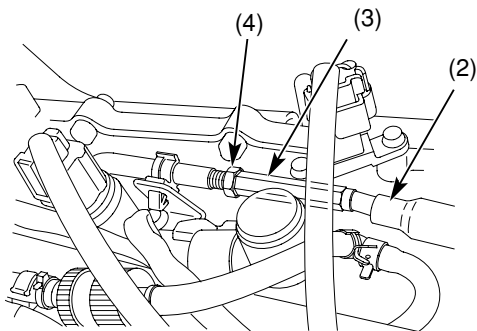

- (2) sleeve (3) adjuster
(4) lock nut

Adjustment

For throttle adjustments, use the adjuster shown in the illustration.

1. Remove the seat (page 117).
2. Slide the sleeve (2) back to expose the adjuster (3).
3. Loosen the lock nut (4).
4. Turn the adjuster (3).
5. After adjustment, check for smooth operation of the throttle lever from fully ON to fully OFF in all steering positions.
6. Reinstall the sleeve.
7. Install the seat.

Throttle Inspection

Refer to *Safety Precautions* on page 104.

1. Check that the throttle assembly is positioned properly and the securing bolts are tight.
2. Check for smooth operation of the throttle lever from fully ON to fully OFF in all steering positions. If there is a problem, see your Honda PWC dealer.

Engine Idle Speed

Remember, idle speed adjustment is not a “cure-all” for other problems in your engine’s fuel-delivery system. Adjusting the idle will not compensate for a fault elsewhere.

The engine must be at normal operating temperature and your PWC must be in the water for accurate idle speed adjustment.

If the idle speed differs from the following value, see your Honda PWC dealer.

Idle speed:
 $1,200 \pm 100$ rpm

Spark Plug Recommendation

standard spark plug	IMR9D-9H (NGK)
---------------------	----------------

Use only the recommended type of spark plugs in the recommended heat range. It should not be necessary to use spark plugs in a different heat range because the engine is water-cooled.

NOTICE

Using spark plugs with an improper heat range can cause engine damage.

This PWC uses spark plugs that have an iridium coated center electrode. Be sure to observe the following when servicing the spark plugs.

- Do not clean the spark plugs. If an electrode is contaminated with accumulated objects or dirt, replace the spark plug with a new one.
- Use only a “wire-type feeler gauge” to check the spark plug gap. To prevent damaging the iridium coating of the center electrode, never use a “leaf-type feeler gauge.”

Spark Plugs

Spark Plug Inspection & Replacement

Refer to *Safety Precautions* on page 104.

1. Remove the seat (page 117).
2. Disconnect the ignition connectors (1) and remove the bolts (2).

NOTICE

Getting the ignition connectors wet can damage the ignition system.

ENGINE COMPARTMENT

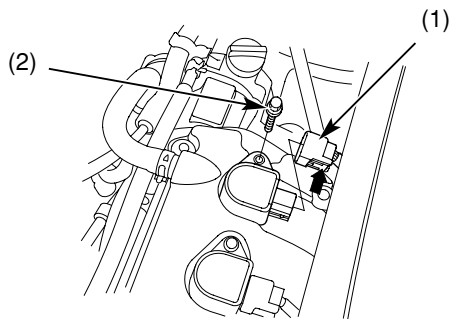

(1) ignition connectors (2) bolts

Spark Plugs

3. Remove the ignition coils (3) from the spark plugs.

ENGINE COMPARTMENT

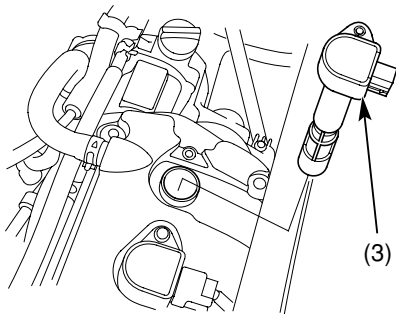

(3) ignition coils

4. Using the spark plug wrench (4) provided in the tool kit, remove the spark plugs.

ENGINE COMPARTMENT

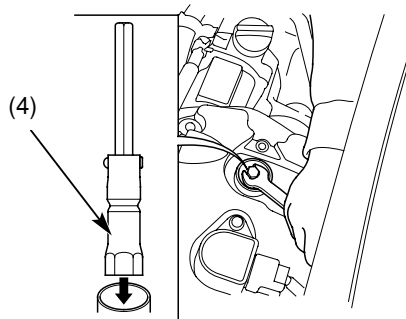

(4) spark plug wrench

(cont'd)

Spark Plugs

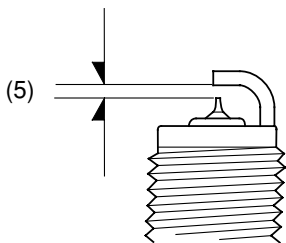

(5) spark plug gap

5. Inspect the electrodes and center porcelain for deposits, corrosion, or carbon fouling. If the corrosion or deposits are heavy, replace the plug.
6. Make sure that a 1.0 mm wire-type feeler gauge cannot be inserted between the spark plug gap (5). If the gauge fits in the gap, replace the plug with a new one.
7. With the plug washers attached, thread the spark plugs in by hand to prevent cross-threading.

8. Tighten each spark plug:
 - If the old plug is good:
1/8 turn after it seats.
 - If installing a new plug, tighten it twice to prevent loosening:
 - a) First, tighten the plug:
NGK: 1/2 turn after it seats.
 - b) Then loosen the plug.
 - c) Next, tighten the plug again:
1/8 turn after it seats.

NOTICE

Improperly tightened spark plugs can damage the engine. Too loose, you can burn a piston. Too tight, you can damage the threads.

9. Reinstall the ignition coils, bolts and connect the ignition connectors.
10. Install the seat.

Engine Cooling System

Always flush the engine cooling system after using your PWC.

Flushing the system with fresh water prevents salt water corrosion and removes silt, sand, and other residue.

If you beach your PWC, be sure to flush the cooling system to avoid possible engine damage.

You may also use the flushing procedure to provide engine cooling when you are running the engine out of the water for maintenance purposes.

The flushing connector is located in the jet nozzle cavity (page 154) at the rear of your PWC.

While flushing the system, observe the following suggestions to avoid engine damage or personal injury:

- Do not touch any electrical parts or driveshaft components while the engine is running.

Engine Cooling System

Flushing Procedure

Refer to *Safety Precautions* on page 104.

⚠ CAUTION

When running the engine on land, hot water and steam can spurt from the cooling water bypass outlet and the exhaust outlet and may cause burns to people in the area.

Keep people away from the rear of the personal watercraft when the engine is running.

Check that the stern is lower than the bow.

1. Pull the reverse lever to lower the reverse bucket (page 45).

2. Attach a garden hose (1) to the flushing connector (2), but do not turn on the water. (If your hose has a male-threaded end, attach a commercially-available female hose adapter (3), or use a section about two feet long cut from the female-threaded end of a second hose.)

REAR

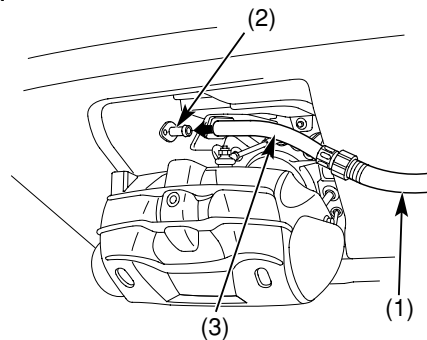

- (1) garden hose (2) flushing connector
(3) hose adapter

Engine Cooling System

3. Start the engine.

NOTICE

Start the engine before turning on the water to prevent flow through the exhaust pipe back into the engine where it could cause severe damage.

4. Immediately after starting the engine, turn on the water flow.

NOTICE

Running the engine without water flow for more than 15 seconds can cause severe engine and exhaust system damage.

5. Check that water flows out of the cooling water bypass outlet.

If you don't see water flowing out of the outlet, turn off the water and the engine. Contact your Honda PWC dealer.

6. Let the engine idle for about 10 minutes while continuing the water flow.

If the engine stops during this procedure, immediately stop the water flow and resume from step 3.

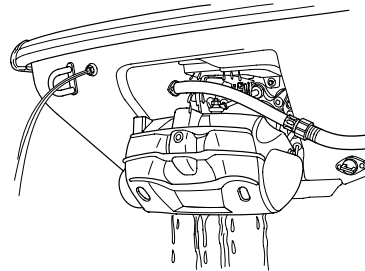

(cont'd)

Engine Cooling System

7. Turn off the water while leaving the engine idling.
8. Check the tachometer while running the engine for less than 15 seconds to rev the engine below approx.

NOTICE

Operating the engine out of water at high rpm or for longer than 15 seconds at a time may cause severe engine and/or exhaust system damage.

9. Stop the engine.
10. Disconnect the garden hose from the flushing connector.
11. Push the reverse lever to pull up the reverse bucket.

Bilge Drain System

Refer to *Safety Precautions* on page 104.

The bilge system, which drains water from the engine compartment, should be flushed periodically according to the Maintenance Schedule, or whenever blockage is suspected.

Be sure to remove the lock clip from the engine stop button/switch.

1. Remove the seat (page 117), rear cover (page 113), and the rear tray (page 114) to access the engine compartment.
2. Push out the bilge strainer (1) while sliding it.

ENGINE COMPARTMENT

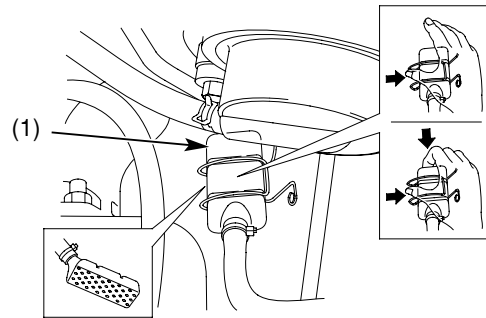

(1) bilge strainer

(cont'd)

Bilge Drain System

3. Clean the bilge strainer in fresh water.
4. Check for clogging by spraying water from the bilge strainer side. Water should flow out of the bilge drain nozzle in the jet pump.
If the bilge strainer or other parts of the bilge drain system are clogged or damaged, replace as necessary. See your Honda PWC dealer.
5. Remove the bilge drain plugs to drain the engine compartment (page 47).

6. Inspect the plugs for cracks or damage. Replace if necessary. Tighten the plugs securely.
7. Install the bilge strainer.
8. Install the rear tray, rear cover and seat.

Off-throttle Steering System

Your PWC is equipped with an “off-throttle steering system” (page 90).

Checking System Operation

1. Insert the lock clip in the engine stop switch to turn on the display.
2. Switch the multi-function meter (1) to the tachometer mode by pushing the MODE button (2).
3. Perform the flushing procedure (page 154).

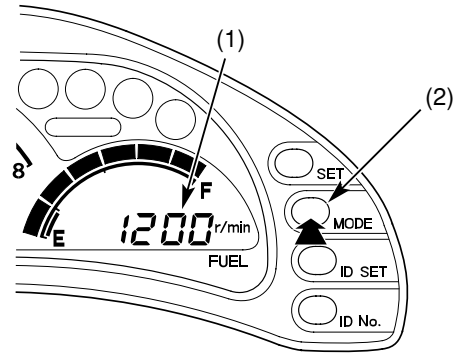

- (1) multi-function meter
(2) MODE button

(cont'd)

Off-throttle Steering System

4. Open the throttle and rev the engine up to approximately 4,000 rpm for a few seconds.
5. Fully close the throttle and turn the steering fully to the right or to the left and hold it.
6. With the handlebar turned, check that the left and right segments (3) alternate rapid flashing as illustrated, and the engine is revving up.

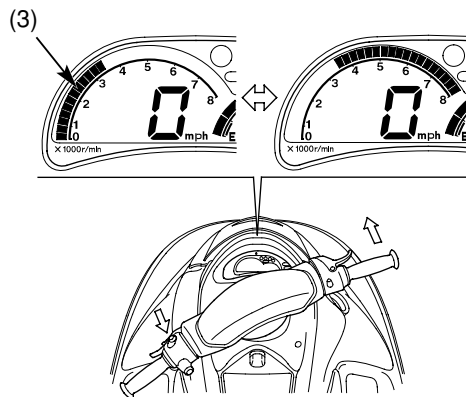

(3) segments

Your PWC has a maintenance-free type battery. You do not have to check the battery electrolyte level or add distilled water as you would with a conventional-type battery.

NOTICE

Your battery is a maintenance-free type and can be permanently damaged if the cap strip is removed.

If you do not expect to ride your PWC for at least two weeks, we recommend you remove the battery – or at least disconnect the battery cables (negative cable first).

If you plan to store your PWC, see *Battery Storage*, page 162.

If your battery seems weak and/or is leaking electrolyte (causing slow starting or other electrical problems), see your Honda PWC dealer.

WARNING: Battery posts, terminals and related accessories contain lead and lead compounds. **Wash hands after handling.**

Battery

Battery Storage

Refer to *Safety Precautions* on page 104.

If you plan to store your PWC, we recommend you remove the battery and store it where it can be charged at least every 30 days to maintain its service life.

If you do not remove the battery, we recommend disconnecting the battery cables (negative cable first) .

You will get the best storage results from removing the battery and slow (trickle) charging it every 30 days (see *Battery Charging*, page 164) .

Before you remove the battery for the first time, be sure to read all the information that follows. After removing the battery, be sure to read the information on the battery label.

WARNING

The battery gives off explosive hydrogen gas during normal operation.

A spark or flame can cause the battery to explode with enough force to kill or seriously hurt you.

Wear protective clothing and a face shield, or have a skilled mechanic do the battery maintenance.

Battery

The battery is located in a battery tray in the engine compartment below the rear tray.

1. Remove the seat (page 117), rear cover (page 113), rear tray (page 114) and wait a few minutes for the engine to ventilate.
2. Disconnect the negative (-) terminal lead (1) from the battery first.

Always disconnect the negative (black) cable first. Fuel vapors may be present in the engine compartment which a spark could ignite.

3. Disconnect the positive (+) terminal lead (2) .
4. Release the rings and remove the rubber bands (3) .
5. Pull the battery (4) out of the battery tray.

ENGINE COMPARTMENT

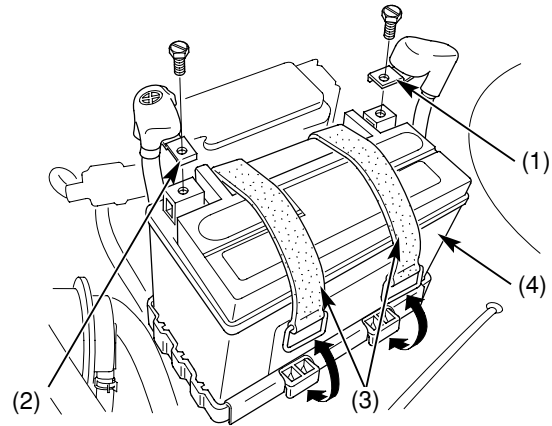

- (1) negative (-) terminal lead (black)
- (2) positive (+) terminal lead (red)
- (3) rubber bands
- (4) battery

(cont'd)

Battery

6. Charge the battery (see following section), unless you have been riding regularly.
7. Clean the top of the battery and the terminals using a baking soda/water solution.
8. Scrape off the deposits with a wire brush.
9. Rinse the battery with fresh water and dry it.
10. Use waterproof grease to coat the terminals.
11. Store your battery in an easy-to-reach location off the floor, in an area protected from freezing temperatures and direct sunlight.
12. Clean the battery tray after removing the battery for storage. Dry the battery tray and, if paint is missing, re-paint the area.
13. Slow charge the battery (see following section) once every 30 days.

Battery Charging

Refer to *Safety Precautions* on page 104.

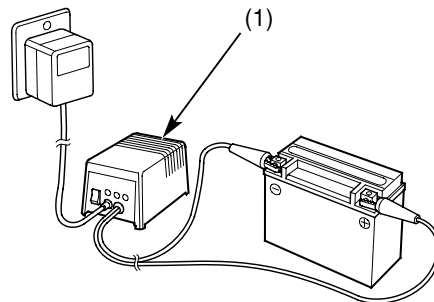

(1) "trickle" charger

Be sure to read the information that came with your battery charger and follow the instructions on the battery. Improper charging may damage the battery.

We recommend using a "trickle" charger (1) for home charging. These units can be left connected for long periods without risking damage to the battery. However, do not intentionally leave the charger connected longer than the time period recommended in the charger's instructions.

Avoid using an automotive-type battery charger. An automotive charger can overheat a PWC battery and cause permanent damage.

Appearance Care

Frequent cleaning and polishing will keep your Honda looking newer longer. Frequent cleaning also identifies you as an owner who values your PWC. A clean personal watercraft is also easier to inspect and service.

Periodically, the engine compartment should be cleaned by your Honda PWC dealer to remove fuel/oil/electrolyte deposits and mildew.

General Recommendations

Refer to *Safety Precautions* on page 104.

- To clean your PWC, you may use:
 - mild, neutral detergent and fresh water.
 - marine boat wax (for use on fiberglass gelcoat)

- We recommend the use of a garden hose to wash your PWC.

NOTICE

High pressure water (or air) can damage certain parts of your personal watercraft.

- After cleaning, inspect for damage, wear, and leaks (fuel and oil).

Washing Your PWC with a Mild Detergent

Refer to *Safety Precautions* on page 104.

1. Rinse your PWC thoroughly with cool water. Spray the hull, deck, handlebar, and drive system.
2. Fill a bucket with cool water. Mix in a mild, neutral detergent, such as dish washing liquid or a product made especially for washing PWC or automobiles.
3. Rinse the engine and the engine compartment with fresh water. Dry with clean rags and spray a water-displacement corrosion-proof lubricant (without Teflon or molybdenum additives, such as CRC 6-56 or equivalent) on the engine.

(cont'd)

Appearance Care

- ARX1200T2 only: Clean the turbocharger in the same manner. Over time, rust may appear on the outside of the turbocharger. This rust does not affect the performance of the unit.
4. Wash your PWC with a sponge or a soft towel.
 5. After washing, rinse your PWC thoroughly with plenty of clean water to remove any residue. Defergent residue can corrode alloy parts.
 6. Dry your PWC with a chamois or a soft towel. Leaving water on the surface to air dry can cause dulling and water spots. As you dry, inspect for chips and scratches.

Finishing Touches

Refer to *Safety Precautions* on page 104.

After washing your PWC, consider using a commercially-available quality fiberglass marine wax to finish the job. Apply only a non-abrasive wax made specifically for marine use. Apply the wax to the hull and deck according to the instructions on the container.

If the fiberglass is damaged, see your Honda PWC dealer.

Here's a few helpful tips on how to store and transport your Honda, and how to be an environmentally responsible PWC owner.

Storing Your Honda	170
Transporting Your PWC	177
You & the Environment	178

Storing Your Honda

Your PWC should not be left in the water for extended periods.

If you won't be riding for an extended period, such as during the winter, or any period longer than one month, thoroughly inspect your PWC and correct any problem before storing it. That way, needed repairs won't be forgotten and it will be easier to get your PWC running again.

We suggest you perform the following procedures to keep your PWC in top condition. These storage procedures will reduce the deterioration that can occur during storage.

We recommend that the following storage procedures be performed by your Honda PWC dealer.

Preparation for Storage

Refer to *Safety Precautions* on page 104.

This procedure requires a means for disposing of drained fuel (page 178).

WARNING

Gasoline is highly flammable and explosive. You can be burned or seriously injured when handling fuel.

- Stop the engine and keep heat, sparks and flame away.
- Handle fuel only outdoors.
- Wipe up spills immediately.

Storing Your Honda

1. Flush the engine cooling system (page 154). After flushing, disconnect the garden hose.
2. Remove the bilge drain plugs to drain any water. Raise the bow (front) of your PWC about 1 foot to allow complete draining.
3. When storing the PWC in an area where the temperature drops below freezing, perform the following:
 - Attach a funnel onto an end of a garden hose and connect the other end to the flushing connector.
 - Prepare approx. 5 liters of a 50/50 solution of antifreeze (Use Pro Honda HP coolant or an equivalent).
 - Following the flushing procedures for the engine cooling system, funnel the antifreeze solution into the engine (page 154).
 - Keep the funnel approximately 51.2 inches (130 cm) above the deck.

- Check that the antifreeze solution is coming out of the cooling water bypass outlet and the jet pump. Use containers to collect the solution and dispose of it in an approved manner (page 178). Do not remove any containers until all storage procedures have been completed.

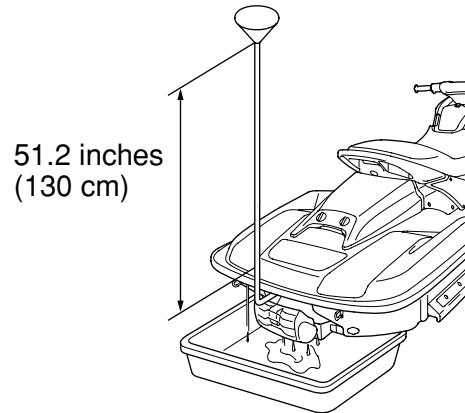

Storing Your Honda

4. To prevent rusting the inlet valves, proceed as follows after confirming the engine is cool.
- Remove the seat (page 117).
 - Disconnect the maintenance joint (page 138).
 - Start the engine at idle speed (without pulling the throttle lever) and spray a water-displacement corrosion-proof lubricant (without Teflon or molybdenum additives, such as CRC 6-56 or an equivalent) into joint hole A for 5 seconds. Refer to the illustration of page 139.
 - Then immediately stop the engine.
 - Perform the same procedure for joint hole B.
 - Reconnect the maintenance joint and make sure it tightened securely.

NOTICE

Avoid running the engine without water flow for more than 15 seconds to prevent severe engine and exhaust system damage.

Storing Your Honda

5. To prevent rusting in the cylinders, perform the following:
 - Disconnect the ignition coil connectors and ignition coils from the spark plugs.
 - Remove the spark plugs from the engine and store them in a safe place. Do not connect the ignition coils to the ignition coil connectors.
 - Pour a tablespoon (15–20 cc) of clean engine oil into each cylinder and cover the spark plug holes with a piece of cloth.
 - Disconnect the injector connectors for each cylinder.
 - Push the start button several times to crank the engine and distribute the oil.
 - After cleaning the spark plug holes, reinstall the spark plugs and the ignition coils.
 - Reconnect the ignition coil connectors and injector connectors.
6. Spray a water-displacement corrosion-proof lubricant (without Teflon or molybdenum additives, such as CRC 6-56 or an equivalent) into the throttle body (pages 139-140).
7. Using a commercially-available fluid evacuator, drain the fuel.

(cont'd)

Storing Your Honda

8. Rinse the outside of the engine. Dry with a soft clean cloth and spray with a water-displacement corrosion-proof lubricant (without Teflon or molybdenum additives, such as CRC 6-56 or an equivalent). (ARX1200T2 only: Also rinse and dry the turbocharger, and spray it with the same lubricant. For turbocharger lubrication, see page 144.)
9. Remove the battery and charge it fully. Store it in an area protected from freezing temperatures and direct sunlight. Slow charge the battery (page 164) once a month.
10. Wash and dry your PWC. Apply fiberglass marine wax to the hull and deck.
11. Lubricate the moving parts (page 138).
12. Store your PWC in an unheated area, free of dampness, away from sunlight, with a minimum of daily temperature variation.
13. Remove the seat (page 117) to allow the engine compartment to dry thoroughly.
14. After the engine compartment is dry, reinstall the seat (page 117).
15. Keep your PWC as level as possible and cover your it with a porous material. Avoid using plastic or similar nonbreathing, coated materials that restrict air flow and allow heat and moisture to accumulate.

Removal from Storage

Refer to *Safety Precautions* on page 104.

1. Uncover and clean your PWC.
2. If your PWC has been stored for more than four months – change the engine oil (page 129).
3. Charge the battery (page 164) as required. Install the battery.
4. Check the throttle lever moves smoothly without sticking, and snaps shut automatically when it is released, in all steering positions.
5. Lubricate the moving parts (page 138).
6. Before starting, remove the seat and front storage box to ventilate the engine compartment.

WARNING

Starting the engine without ventilating the engine compartment can cause a fire or explosion and you or others could be seriously injured or killed.

Always vent the engine compartment before starting the engine.

(cont'd)

Storing Your Honda

7. Perform the engine flushing procedure (page 154).
8. Check all hoses for cracking, and looseness.
 - Continue flushing until the antifreeze solution stops coming out.
 - Use containers to collect the solution and dispose of it in an approved manner (page 178).
9. Install the bilge drain plugs. Check they are secure.
10. Check the fire extinguisher is not beyond its expiration date and charge or replace, if necessary.

Transporting Your PWC

Your PWC should be carried on a trailer designed for its hull design and weight. Check that the trailer meets all local regulations.

Before transporting your PWC, make sure all compartments, covers, and the seat are secure and the reverse bucket is up.

Use tie downs on the bow and stern eyelets to secure your PWC to the trailer.

Do not route a tie down or rope over the seat or wrap them around the handlebar. Do not use the grab rail. Use padding wherever a tiedown or rope contacts the hull or deck.

Use a PWC cover, especially if you will be driving on dirt roads.

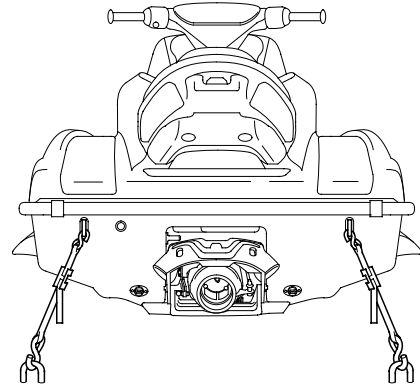
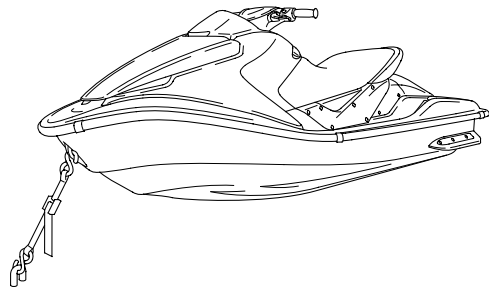

You & The Environment

Owning and riding a PWC can be enjoyable, but you must do your part to protect nature. When you show respect for the waterways, wildlife, and other people, you also help preserve the PWC sport.

Following are tips on how you can be an environmentally-responsible PWC owner.

- **Ride in Approved Areas.** Ride responsibly only in areas approved for PWC. Avoid shoreline homes, wildlife areas, other boats, and swimmers.
- **Keep the Noise Down.** Loud personal watercraft can be offensive. Ride as quietly as possible. Don't modify the muffler or any other part of your air intake and exhaust systems. Such modifications not only increase noise, they also reduce engine performance and may be illegal.

- **Refuel Carefully.** If you pump gasoline at a dock, take care not to spill. Gasoline in the water can poison wildlife and people. If you spill gasoline, immediately wipe it up with a rag and dispose of it properly. A little attention on your part can do a lot to help preserve the environment and ensure that you'll have places to ride your PWC in the future.
- **Choose Sensible Cleaners.** Use a biodegradable detergent when you wash your PWC. Avoid aerosol spray cleaners that contain chlorofluorocarbons (CFCs) which damage the atmosphere's protective ozone layer. Don't throw cleaning solvents away; see the following guidelines for proper disposal.

- **Recycle Wastes.** It's illegal and thoughtless to put used engine oil in the trash, down a drain, or on the ground. Used oil, gasoline, coolant, and cleaning solvents contain poisons that can hurt refuse workers and contaminate our drinking water, lakes, rivers, and oceans. Before changing your oil, make sure you have the proper containers. Put oil and other toxic wastes in separate sealed containers and take them to a recycling center. Call your local or state office of public works or environmental services to find a recycling center in your area, and to get instructions on how to dispose of non-recyclable wastes.

Taking Care of the Unexpected

This section discusses the more common problems that can occur with your PWC while you're riding. It tells you how to evaluate each problem and what actions you can take to try to resume riding.

General Guidelines	182
If Your Engine Quits or Won't Start	183
If Your Engine Overheats	186
If the Low Oil Pressure Indicator Lights .	187
If a Fuse Blows	188
If You Have a Collision	192
If Your PWC Must Be Towed	193
If You Capsize	194
If Your PWC Is Submerged	196
If the Intake or Propulsion System Is Clogged	198
If Your Battery Is Low (or Dead)	200

Taking Care of the Unexpected

General Guidelines

Keeping your PWC well-maintained is the best way to reduce the possibility of having a problem on the water.

Remember to take along your owner's manual, the tool kit that came with your PWC, and additional tools that might help you solve a problem on your own.

Should you ever have a problem while riding, please follow these guidelines:

- Always put personal safety first – head back to land.
- Take time to assess the situation and your options before deciding what to do.
- If the problem is relatively minor and you have the tools, supplies, and skills to make a temporary repair, be sure to have permanent repairs made as soon as possible.
- If you can fix the problem yourself and plan to go out again, perform a pre-ride inspection first.

Additional recommendations for specific problems follow.

If Your Engine Quits or Won't Start

Proper operation and maintenance can prevent starting and engine performance problems. In many cases, the cause of the problem may be a simple operational oversight.

If you have a problem starting the engine – or experience poor engine performance – the following information may help you. If you can't correct the problem, see your Honda PWC dealer.

While some checks and procedures can be performed on the water, most require returning to land.

If your PWC won't start, listen as you push the start button. If you don't hear the starter motor turning, refer to the *Starter motor doesn't operate* symptom. If you can hear the starter motor working normally, refer to the *Starter motor works, but the engine won't start* symptom.

If Your Engine Quits or Won't Start

SYMPTOM: Starter motor doesn't operate.	
POSSIBLE CAUSE	WHAT TO DO
blown fuse	Replace with a new fuse of the same rating (page 188) .
battery lead loose	Tighten the battery lead.
dead battery	Charge the battery (page 164) . If charging doesn't help, see your Honda PWC dealer.
faulty starter motor	If all possible causes are negative, the starter motor may be faulty. See your Honda PWC dealer.
lock clip not inserted	Insert the lock clip in the engine stop button/switch.
ID lock system not deactivated	Enter the ID number. If you forget the ID number, see your Honda PWC dealer.

SYMPTOM: Starter motor works, but the engine won't start.	
POSSIBLE CAUSE	WHAT TO DO
out of fuel	Fill the fuel tank
flooded engine	See <i>Flooded Engine</i> (page 77) .
loose or unconnected ignition coil connectors and ignition coils	Install the ignition coil connectors and ignition coils securely. If the engine still won't start, see your Honda PWC dealer.
loose battery cables	Tighten the battery terminal bolts.
weak battery	Charge the battery (page 164) . If charging doesn't help, see your Honda PWC dealer.

If Your Engine Quits or Won't Start

SYMPTOM: Engine starts, but runs poorly.	
POSSIBLE CAUSE	WHAT TO DO
idles roughly, too fast, stalls	See your Honda PWC dealer.
overheating	Check the cooling water bypass outlet. If water is not flowing, shut off the engine. Refer to <i>If Your Engine Overheats</i> , page 186.
low oil pressure	Check the low oil pressure indicator. Refer to <i>If the Low Oil Pressure Indicator Lights</i> , page 187.
runs erratically, misfires	See your Honda PWC dealer.
blubbers (rich fuel mixture)	See your Honda PWC dealer.
sooty exhaust (rich fuel mixture)	See your Honda PWC dealer.
detonates or pings under load	If applicable, switch to the recommended octane gasoline (page 119) or change your brand of gasoline. If the problem persists, see your Honda PWC dealer.
afterfires (backfires)	See your Honda PWC dealer.

If Your Engine Overheats

If your engine overheats, the multi-function display will show a warning message, the engine cooling water temperature indicator and the WARNING lamp will flash, and you will hear a warning beeper.

To stop the warning beeper, press and hold any one of the four control buttons (SET, MODE, ID SET, or ID No.) for about 2 seconds.

If the engine cooling water temperature reaches a certain level, engine revs are automatically limited to 3,000 rpm to prevent damage. If the temperature continues rising, the engine will automatically shut off and cannot be restarted until the temperature drops.

- Return to shore immediately and shut off the engine. Allow it to cool.
- Check inside of the hull. If a large amount of bilge water is found, check connection of

- the water hoses in the cooling system.
- Inspect the jet pump water intake for clogging.
- Inspect the impeller for clogging.
- Flush the cooling system (page 154).
- After taking the above-mentioned measures or if there is no obvious problem, start the engine and slowly ride the PWC (under 3,000 rpm). Monitor the engine cooling water temperature indicator. If the engine still overheats, shut off the engine. Transport your PWC to a Honda PWC dealer (page 177).

NOTICE

Continuing to ride with an overheated engine can cause serious engine damage.

If the Low Oil Pressure Indicator Lights

If you check your engine oil level regularly, you should never see the low oil pressure indicator while riding.

Low oil pressure may be caused by an oil leak, a low oil level, or some problem in the engine's lubrication system.

If the indicator and the WARNING lamp come on and hear a warning beeper while you're riding, don't ignore it. Return to shore and stop the engine as soon as it's safe to do so.

To stop the warning beeper, press and hold any one of the four control buttons (SET, MODE, ID SET, or ID No.) for about 2 seconds.

If the oil pressure drops below a certain level, engine revs are automatically limited to 3,000 rpm. If the pressure continues dropping, the engine will automatically shut off and cannot be restarted until the pressure problem is

solved.

- Check for an oil leak.
- Then check the oil level. If necessary, add the recommended oil (page 124) to the upper level mark on the tank.
- After adding oil, start the engine, and check that the low oil pressure indicator goes off. Check for a possible leak.

If the indicator goes off and there is no leak — resume riding. If there is a leak — do not ride the PWC until the leak is repaired by a Honda PWC dealer.

NOTICE

Continuing to ride with low oil pressure can cause serious engine damage.

If a Fuse Blows

All of the electrical circuits on your PWC have fuses to protect them from damage caused by excess current flow (short circuit or overload) .

If something electrical on your PWC stops working, the first thing you should check for is a blown fuse. Determine from the chart on the circuit fuse box cover which fuse or fuses control that component. Check those fuses first, but check all the fuses before looking elsewhere for another possible cause of the problem. Replace any blown fuses and check component operation.

The circuit fuse box is located in the engine compartment below the rear tray.

Recommended Fuses

main fuse	30 A
other fuses	5 A, 7.5 A

To prevent an accidental short circuit, remove the lock clip before checking or replacing the fuses.

If a Fuse Blows

Main Fuse Access:

1. To access the main fuse (1), remove the seat (page 117), rear cover (page 113), and the rear tray (page 114).
2. Remove the fuse box cover (2).

ENGINE COMPARTMENT

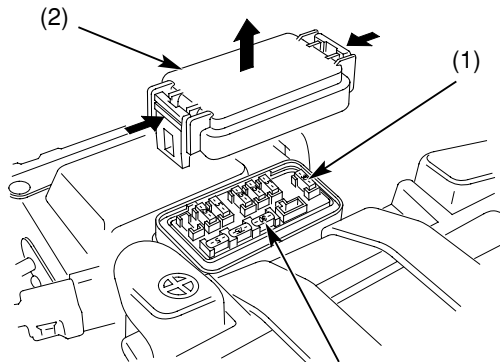

- (1) main fuse
- (2) fuse box cover
- (4) spare main fuse

3. Pull the main fuse out.
If it is blown (3), install the spare main fuse (4).

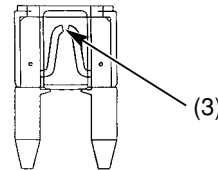

- (3) blown fuse

(cont'd)

If a Fuse Blows

Circuit Fuse Access:

4. To check or replace a circuit fuse, pull the old fuse out of its retaining clips. Look for a burned wire inside the fuse. If the fuse is blown (3), replace it with a spare fuse (5) of the same rating or lower.
5. Install the fuse box cover.
6. Install the rear tray (page 114), rear cover (page 113), and the seat (page 117).

If you do not have a spare fuse and you cannot ride the PWC without fixing the problem, take a fuse of the same rating or a lower rating from one of the other circuits that you can do without temporarily.

NOTICE

Replacing a fuse with one that has a higher rating greatly increases the chance of damage to the electrical system.

ENGINE COMPARTMENT

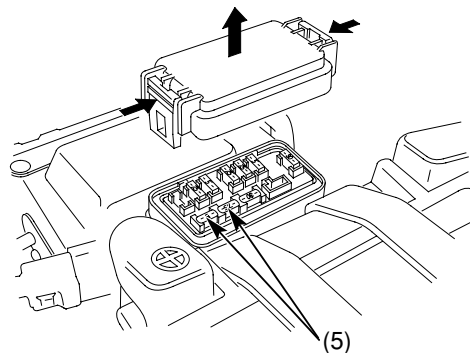

(5) spare fuses

If a Fuse Blows

If you replace a blown fuse with a spare fuse that has a lower rating, replace the fuse with the correct rating as soon as you can. Also remember to replace any spare fuses that were installed.

If the replacement fuse of the same rating burns out in a short time, there is probably a serious electrical problem on your PWC. Leave the blown fuse in that circuit and have your PWC checked by your Honda PWC dealer.

If You Have a Collision

Personal safety is your first priority after any accident. If you or anyone else has been injured, take time to assess the severity of the injuries. Call for emergency assistance if needed, and head for shore. Also follow applicable laws and regulations if another person or vehicle is involved in the accident.

If you decide it is possible to ride safely, carefully inspect your PWC for damage and determine if it is safe to ride. Check the tightness of critical nuts and bolts securing such parts as the handlebar, throttle lever, and jet pump steering nozzle. Also check the operation of these parts.

No matter how much damage there is, ride slowly and cautiously toward shore. Depending on how severe the damage is, you may need to be towed to shore. Sometimes, collision damage is hidden or not immediately apparent, so you should have your PWC thoroughly checked by a Honda PWC dealer as soon as possible.

If Your PWC Must Be Towed

If you run out of fuel, have engine problems, or have collision damage, you can attach a tow line to the bow eyelet so your PWC may be towed to shore.

Do not attach a tow line anywhere on the PWC except the bow eyelet.

- The recommended tow rope length is three times the combined length of the towing boat and your PWC.
- If you use a tow line, take care to keep it away from the propeller of the towing boat.
- The towing boat should slowly pull away from the PWC until the tow rope slack is taken up.

You should ride on your PWC, holding the handlebar, as it is towed.

NOTICE

Towing your personal watercraft at speeds exceeding 10 mph can cause water to flood into the engine.

Keep the tow speed below 10 mph.

If You Capsize

Your PWC is designed to resist capsizing. However, if your PWC does turn over, it will remain capsized until you right it again.

Act quickly to turn the boat back upright. If your PWC remains capsized, you will probably have some problems.

Serious damage can be caused if the engine runs while your PWC is capsized. This is another reason why it is important to always insert the lock clip in the engine stop button/switch and wear the safety lanyard before you operate your PWC.

1. Make sure the engine is off. If the lock clip is still in the engine stop button/switch, remove it.
2. Swim to the rear of your PWC.

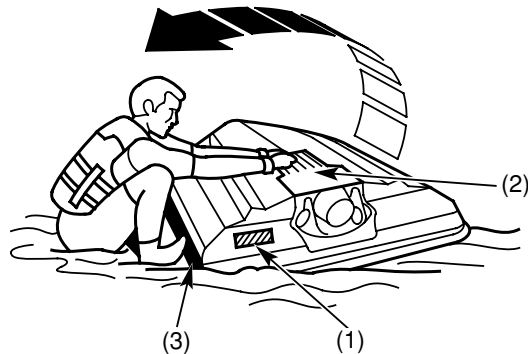

- (1) uprighting procedure label
- (2) grate
- (3) outside bumper

If You Capsize

3. Look for the uprighting procedure label (1) (on the left side when capsized, viewed from the rear).
4. Make sure the area is clear of people and passenger, then grab the intake grate (2) with both hands and pull the PWC over toward you while pushing down on the side of the hull nearest you.
5. As your PWC rolls over, remove your hands from the intake grate and grab the outside bumper (3).
6. Get out of the way as the PWC completes its rotation.
7. Remove the seat (page 117), rear cover (page 113), and the rear tray (page 114), and check for flooding of engine compartment.
 - If the engine compartment is badly flooded, do not start the engine, and have someone tow your PWC to land. Drain water from the engine compartment, then take your PWC to your Honda PWC dealer.
 - If the engine compartment is not badly flooded, go to step 8.
8. Insert the lock clip in the engine stop button/switch.
9. Push the start button.

If the engine starts, you can continue riding.
10. If the engine does not start, do not attempt repeated starts. Get towed to shore. Refer to *If Your PWC Is Submerged*, page 196.
11. See your Honda PWC dealer immediately to avoid possible severe engine damage.

If Your PWC Is Submerged

Your PWC will not sink, but if it is submerged or flooded with water, act quickly to avoid severe engine damage.

1. Remove your PWC from the water.
2. Remove the bilge drain plugs to drain the water out of the engine compartment.
3. Check the transparent section of the air box drain tube.
If you can see water, pull the plug on the end of the tube to drain the air box.
4. Disconnect the ignition coil connectors and ignition coils from the spark plugs.
5. Remove the spark plugs from the engine and store them in a safe place and put the soft cloths on the plug holes. Do not connect the ignition coils to the ignition coil connectors.
6. Disconnect the injector connectors.
7. Open the throttle fully.

8. Press the start button for 15 seconds. Continue this procedure until water stops coming out.
9. Remove the soft cloths and pour a tablespoon (15–20cc) of clean engine oil into each cylinder.
10. Push the start button several times to crank the engine and distribute the oil.
11. After cleaning the spark plug holes, reinstall the spark plugs and the ignition coils.
12. Remove the air box cover and check the air filter.
If the filter is wet, remove the filter and dry it.
Do not use compressed air to dry the air filter.
13. Reconnect the ignition coil connectors and the injector connectors.
14. Take your PWC to your Honda PWC dealer as soon as possible.

If Your PWC Is Submerged

Letting your PWC sit overnight with water in the engine, especially with more corrosive salt water, may cause severe engine damage.

If a Honda PWC dealer is not available:

1. Change the engine oil and filter (page 130).
2. Using the flushing procedure (page 154), run the engine for at least 10 minutes to remove any moisture left in the combustion chamber.
3. After stopping the engine, check the oil. If it appears milky (indicating water contamination), change the oil and filter again.

If the Intake or Propulsion System Is Clogged

If riding over water heavy with weeds is unavoidable, vary throttle input to reduce the chances of clogging the intake system.

If the intake/propulsion system is clogged by weeds or other debris, you may experience one or two problems. Reduced water jet thrust may slow your water speed even as you increase engine rpm with the throttle lever. The reduction of water flow may also cause the engine to overheat.

Before attempting to clean the intake/propulsion system, always remove the lock clip from the engine stop button/switch to prevent accidental engine starting.

If the Intake or Propulsion System Is Clogged

Cleaning the Intake/Propulsion System on the Shore

1. After shutting the engine off, remove your PWC from the water.
2. Remove the lock clip from the engine stop button/switch.
3. Disconnect the battery cables.
4. If possible, use a protective pad or cardboard to prevent scratching when you turn your PWC on its side for cleaning.
5. Rotate your PWC clockwise (from the rear, 90° max.) to its right side. Do not push the engine start button.

NOTICE

Rotating the personal watercraft counterclockwise to its left side, and maintaining this position while cleaning the intake system, could allow a substantial amount of oil to leak from the engine.

6. Check and, if necessary, clean all components (intake grate, driveshaft, impeller, jet pump steering nozzle) of the water intake/propulsion system.
7. After uprighting your PWC, check for leaks in the engine compartment.

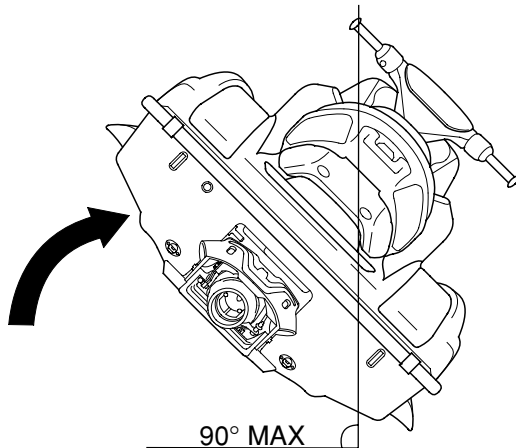

If Your Battery Is Low (or Dead)

Jump starting is not recommended, especially if you use an automobile battery. The greater amperage of an automobile battery when the car engine is running can damage your PWC's electrical system.

Do not charge the battery while it is installed in the PWC.

If you can't charge the battery or it appears unable to hold a charge, contact your Honda PWC dealer.

Technical Information

This section contains dimensions, capacities, and other technical data, plus information on government requirements and how to break-in your PWC.

Vehicle Identification	202
Specifications	205
Break-in Guidelines	209
Emission Control Systems	210
Star Label	213
Oxygenated Fuels	216

Vehicle Identification

Serial Numbers

The registration (or primary) identification number, hull identification number (HIN), and engine number are required when you register your PWC. They may also be required when ordering replacement parts. You may record these numbers in the *Quick Reference* section at the rear of this manual.

Also record these identification numbers with your other important documents at home in case your PWC is stolen.

Federal law requires that all PWC be registered and numbered. The registration number must appear on both sides of the PWC, above the water line. Make sure the numbering meets all local regulations.

The registration (or primary) identification number (1) is located on both sides of the PWC.

LEFT AND RIGHT SIDE

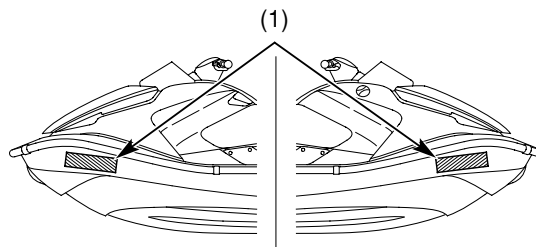

(1) registration identification number

Vehicle Identification

The hull identification number (HIN) (2) is located on the hull at the right side of the PWC.

RIGHT SIDE

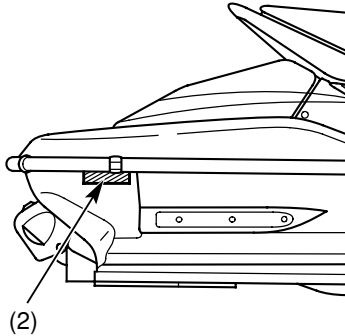

(2) hull identification number (HIN)

The engine number (3) is stamped on the top of the oil tank.

UNDER SEAT

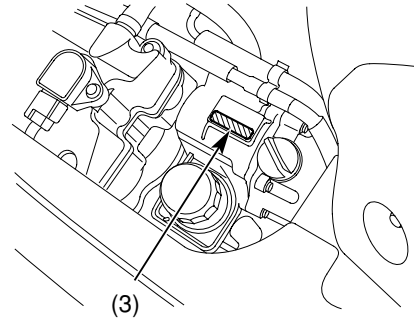

(3) engine number

Vehicle Identification

Color Label & Code

The color label (4) is attached behind the front hood.

The color code is helpful when ordering replacement parts. You may record the color and code in the *Quick Reference* section at the rear of this manual.

BEHIND FRONT HOOD

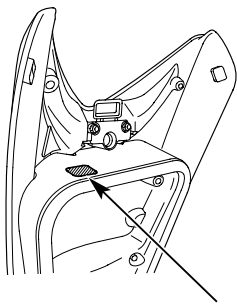

(4) color label

(4)

Specifications

Dimensions	
overall length	120.6 in (3,062 mm)
overall width	45.4 in (1,154 mm)
overall height	40.8 in (1,036 mm)

Weight	
dry weight	ARX1200T2: 746 lbs (338.4 kg)
	ARX1200N2: 715 lbs (324.6 kg)

Fuel & Lubricants	
fuel recommendation	unleaded premium gasoline, pump octane number of 91 or higher
fuel tank capacity	16.64 US gal (63.0 ℓ)
engine oil capacity	ARX1200T2 after disassembly : 5.6 US qt (5.3 ℓ) after draining : 4.4 US qt (4.2 ℓ) after draining & oil filter change : 4.5 US qt (4.3 ℓ)
	ARX1200N2 after disassembly : 5.3 US qt (5.0 ℓ) after draining : 4.2 US qt (4.0 ℓ) after draining & oil filter change : 4.3 US qt (4.1 ℓ)

(cont'd)

Specifications

Fuel & Lubricant (cont'd)	
engine oil recommendation	API Service Classification SG or higher except oils labeled as energy conserving on the API service label SAE 10W-40 JASO 4T Standard MA or MB Pro Honda GN4, HP4 or HP4M 4-stroke oil or an equivalent motorcycle oil
lubricant	Water-displacement corrosion-proof lubricant (without Teflon or molybdenum additives, such as CRC 6-56 or equivalent)
cooling system	Water-cooled, open circuit, direct flow from propulsion system

Capacities	
passenger capacity	operator and one passenger
maximum weight capacity	338 lbs (153.5 kg) rider, passenger, all cargo
cargo capacity	front storage compartment: 6.6 lbs (3 kg) glove box : 1 lbs (0.5 kg)

Specifications

Engine	
engine type	four-stroke
displacement	75.3 cu-in (1,235 cm ³)
bore & stroke	3.11 x 2.48 in (79.0 x 63.0 mm)
spark plug	IMR9D-9H
valve clearance (cold)	intake : 0.006 in (0.16 mm) exhaust : 0.01 in (0.26 mm)
spark plug gap	0.031 – 0.035 in (0.80 – 0.90 mm) no adjustment
idle speed	1,200 ± 100 rpm

Performance	
maximum output	ARX1200T2: 121.4 kW (165 HP)/6,100 rpm ARX1200N2: 91.9 kW (125 HP)/7,000 rpm
fuel consumption	ARX1200T2: 13.84 US gal/hour (52.4 ℓ/hour, at full throttle) ARX1200N2: 9.25 US gal/hour (35.0 ℓ/hour, at full throttle)
cruising range	ARX1200T2: 1.2 hours (at full throttle) ARX1200N2: 1.8 hours (at full throttle)

Specifications

Propulsion System	
jet pump type	Axial flow, single stage
minimum level for jet pump operation	3 feet (90 cm)
impeller	3-blade stainless steel

Hull	
hull material	fiberglass reinforced plastic

Electrical	
battery	12 V-18 AH
generator	0.31 kW/5,000 rpm

Fuses	
main	30 A
other fuses	5 A, 7.5 A

Torque Specifications	
oil filter	20 lbf·ft (26 N·m, 2.7 kgf·m)

Break-in Guidelines

Help assure your PWC's future reliability and performance by paying extra attention to how you ride during the first tank full of fuel.

During the first 5 minutes:

- Use the lowest possible speed (slightly above idle speed).

During the next 15 minutes:

- Run at varying rpm, never exceeding 3,000 rpm.

During the following 15 minutes:

- Run at varying rpm, never exceeding 4,000 rpm.

During the remainder of the first full fuel tank:

- Vary the operating speed often, do not continue running for a long time at any one speed.
- Avoid full-throttle starts and rapid acceleration.
- Use no more than 5,000 rpm.
- Do not carry a passenger.

Emission Control Systems

Exhaust Emission Requirements

The U. S. Environmental Protection Agency (EPA) , the California Air Resources Board (CARB) , and Environment Canada require that your PWC comply with applicable exhaust emissions standards during its useful life, when operated and maintained according to the instructions provided.

The U.S. and California Clean Air Acts

EPA and California regulations require all manufacturers to furnish written instructions describing the operation and maintenance of emission control systems.

The following instructions and procedures must be followed in order to keep the emissions from your Honda engine within the emission standards.

Tampering and Altering

Tampering with or altering the emission control system may increase emissions beyond the legal limit.

Among those acts that constitute tampering are;

- Removal or alteration of any part of the intake, fuel, or exhaust systems.
- Alterations that would cause the engine to operate outside its design parameters.

Emission Control Systems

Warranty Compliance

Compliance with the terms of the Distributor's Warranties for Honda Personal Watercraft Emission Control Systems is necessary in order to keep the emissions system warranty in effect.

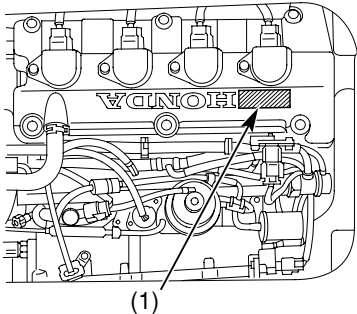

(1) vehicle emission control information label

The vehicle emission control information label (1) is attached on the cylinder head.

Source of Exhaust Emissions

The combustion process produces carbon monoxide (CO), oxides of nitrogen (NO_x), and hydrocarbons (HC). Control of oxides of nitrogen and hydrocarbons is very important because, under certain conditions, they react to form photochemical smog when subjected to sunlight. Carbon monoxide does not react in the same way, but it is toxic.

Honda Motor Co., Ltd. utilizes various systems to reduce carbon monoxide, oxides of nitrogen, and hydrocarbons.

Emission Control Systems

Exhaust Emission Control System

The exhaust emission control system includes a PGM-FI system.

PGM-FI System

The PGM-FI system uses sequential multiport fuel injection. It has three subsystems: Air Intake, Engine Control, and Fuel Control.

The Engine Control Module (ECM) uses various sensors to determine how much air is going into the engine. It then controls how much fuel to inject under all operating conditions.

Ignition Timing Control System

The system constantly adjusts the ignition timing, reducing the amount of HC, CO and NOx produced.

Crankcase Emission Control System

The engine is equipped with a closed crankcase system to prevent discharging crankcase emissions into the atmosphere. Blow-by gas is returned to the combustion chamber through the air cleaner and the intake manifold.

Problems That May Affect PWC Exhaust Emissions

If you are aware of any of the following symptoms, have the vehicle inspected and repaired by your authorized Honda PWC dealer.

Symptoms:

1. Hard starting or stalling after starting
2. Rough idle
3. Misfiring or backfiring during acceleration
4. After-burning (backfiring)
5. Poor performance (driveability) and poor fuel economy

A star label was applied to this PWC in accordance with the requirements of the California Air Resources Board.

The Star Label means Cleaner Marine Engines

This engine has been certified as a:

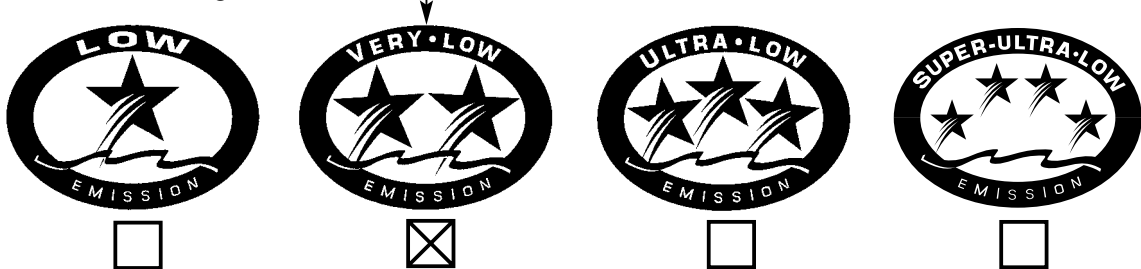

The Symbol for Cleaner Marine Engines:

Cleaner Air and Water - for a healthier lifestyle and environment.

Better Fuel Economy - burns up to 30-40 percent less gas and oil than conventional carbureted two-stroke engines, saving money and resources.

Longer Emission Warranty - protects consumer for worry free operation.

(cont'd)

Star Label



One Star Low Emission

The one-star label identifies engines that meet the Air Resources Board's Personal Watercraft and Outboard marine engine 2001 exhaust emission standards. Engines meeting these standards have 75% lower emissions than conventional carbureted two-stroke engines. These engines are equivalent to the U. S. EPA's 2006 standards for marine engines.



Two Stars Very Low Emission

The two-star label identifies engines that meet the Air Resources Board's Personal Watercraft and Outboard marine engine 2004 exhaust emission standards. Engines meeting these standards have 20 % lower emissions than One Star-Low Emission engines.



Three Stars Ultra Low Emission

The three-star label identifies engines that meet the Air Resources Board's Personal Watercraft and Outboard marine engine 2008 exhaust emission standards or the Sterndrive and Inboard marine engine 2003-2008 exhaust emission standards. Engines meeting these standards have 65% lower emissions than One Star-Low Emission engines.



Four Stars Super Ultra Low Emission

The four-star label identifies engines that meet the Air Resources Board's Sterndrive and Inboard marine engine 2009 exhaust emission standards. Personal Watercraft and Outboard marine engines may also comply with these standards. Engines meeting these standards have 90% lower emissions than One Star-Low Emission engines.

Cleaner Watercraft - Get the Facts
1-800-END-SMOG
www.arb.ca.gov

Oxygenated Fuels

Some conventional gasolines are being blended with alcohol or an ether compound. These gasolines are collectively referred to as oxygenated fuels. To meet clean air standard, some areas of United States and Canada use oxygenated fuels to help reduce emissions. If you use an oxygenated fuel, be sure it is unleaded and meets the minimum octane rating requirement.

Before using an oxygenated fuel, try to confirm the fuel's contents. Some states/provinces require this information to be posted on the pump.

The following are the EPA-approved percentages of oxygenates:

ETHANOL (ethyl or grain alcohol) 10% by Volume

You may use gasoline containing up to 10% ethanol by volume. Gasoline containing ethanol may be marketed under the name "Gasohol."

MTBE (Methyl Tertiary Butyl Ether) 15% by Volume

You may use gasoline containing up to 15% MTBE by volume.

METHANOL (methyl or wood alcohol) 5% by Volume

You may use gasoline containing methanol containing up to 5% methanol by volume as long as it also contains cosolvents and corrosion inhibitors to protect the fuel system. Gasoline containing more than 5% methanol by volume may cause starting and/or performance problems. It may also damage metal, rubber, and plastic parts of your fuel system.

If you notice any undesirable operating symptoms, try another service station or switch to another brand of gasoline.

Fuel system damage or performance problems resulting from the use of an oxygenated fuel containing more than the percentages of oxygenates mentioned above are not covered under warranty.

Oxygenated fuels can damage paint and plastic. Be careful not to spill fuel when filling the fuel tank. Wipe up any spills immediately.

NOTICE

Oxygenated fuels can damage paint and plastic. Damage caused by spilled fuel is not covered by warranty.

Consumer Information

This section contains information on your warranty and how to get an official Honda service manual.

Authorized Manuals	220
Warranty Coverage	223
Warranty Service	224
Contacting Honda	225
Your Honda PWC Dealer	226
The Honda Rider's Club (USA only) ...	227
Reporting Safety Defects (USA only)	228

Authorized Manuals

There are two sources of reference that are available to properly service this PWC. A CD-ROM which contains the Service Manual, Owner's Manual, videos, color wire diagrams and other related information, as well as a high-quality photocopy of the Service Manual.

Also available, but not necessary, to service your PWC is the Honda Common Service Manual which explains theory of operation and basic service information for various systems on this PWC.

These Honda manuals are written for the professional technician, but most mechanically-capable owners should find them easy to use if they have the proper tools and observe proper safety standards. Special Honda tools are necessary for some procedures.

Publication item No.	Description	Price Each*
61HW3C02	2005 ARX1200T2/N2 Service Manual CD-ROM	\$54.00
61HW302	2005 ARX1200T2/N2 Service Manual	\$60.00
61CM002	Common Service Manual	\$48.00
31HW3620	2005 ARX1200T2/N2 Owner's Manual	\$16.00
<i>*Prices are subject to change without notice and without incurring obligation.</i>		

Authorized Manuals

Order On-Line: www.helminc.com

Order Toll Free: 1-888-CYCLE 93 (1-888-292-5393)

(NOTE: For Credit Card Orders Only)

Monday – Friday 8:00 AM – 6:00 PM EST

OR

By completing this form you can order the materials desired. You can pay by check or money order, or charge to your credit card. Mail to Helm, Inc. at the address shown on the back of this order form.

Canada: See your Honda PWC dealer to order authorized manuals.

Publication item No.	Item Description	Qty.	Price Each*	Total Price
*Prices are subject to change without notice and without incurring obligation. Orders are mailed within 10 days. Please allow adequate time for delivery.		Sub total		
		Mich. Purchasers Add 6 % Sales Tax		
		Handling Charge		\$4.00
		Grand total		

Authorized Manuals

**S
H
I
P
T
O**

NOTE: Dealers and Companies please provide dealer or company name, and also the name of the person to whose attention the shipment should be sent.

Customer Name _____ Attention _____

Street Address - No P.O. Box Number _____ Apartment Number _____

City _____ State _____ Zip Code _____

Daytime Telephone Number () _____

**P
A
Y
M
E
N
T**

Check or money order enclosed payable to Helm Inc.
U.S. funds only. Do not send cash.

Check here if your billing address is different
from the shipping address shown above.

MasterCard Account Number
 □□□□ □□□□ □□□□ □□□□

Expiration: Mo. Yr.
 □ □

VISA

Discover

Customer Signature _____ Date _____

These Publications cannot be returned for credit without receiving advance authorization within 14 days of delivery. On returns, a restocking fee may be applied against the original order.

HELM P. O. BOX 07280, DETROIT, MICHIGAN 48207

Warranty Coverage

Your new Honda is covered by these warranties:

- Personal Watercraft Limited Warranty
- Emission Warranty
- Replacement Parts Warranty
- Accessories Warranty

There are responsibilities, restrictions, and exclusions which apply to these warranties. Please read the Warranties Booklet given to you by your Honda PWC dealer at the time of purchase. Be sure to keep your Honda owner's card with your Warranties Booklet. It is important to realize that your warranty applies to defects in material or workmanship of your Honda. Your warranty coverage does not apply to normal wear or deterioration associated with using the PWC.

Your warranty coverage will not be voided if you choose to perform your own maintenance. However, you should have the proper tools and service information and be mechanically qualified. Failures that occur due directly to improper maintenance are not covered.

Almost all of your warranty coverage can be extended through the Honda Protection Plan. For more information, see your Honda PWC dealer.

Warranty Service

Please remember that recommended maintenance interval servicing is not included in your warranty coverage. Additionally, your warranty does not apply to the normal wear of items.

If you believe you have a problem with your PWC, call the service department of your Honda PWC dealer. Make an appointment for an inspection and diagnosis. Remember, as the owner of the PWC, you will be asked to authorize that inspection. Your dealer will give you the results of the inspection. If the problem is covered under warranty, your dealer will perform the warranty repairs for you.

If you have questions about warranty coverage or the nature of the repair, it is best to talk to the service manager of your Honda PWC dealer.

Sometimes, in spite of the best intentions of all concerned, a misunderstanding may occur. If you aren't satisfied with your dealer's handling of the situation, we suggest you discuss your problem with the appropriate member of the dealership's management team. If the problem has already been reviewed with the Service Manager, Parts Manager, Sales Manager, etc., contact the Owner of the dealership or their designated representative.

Contacting Honda

Your owner's manual was written to cover most of the questions you might ask about your Honda. Any questions not answered in the owner's manual can be answered by your Honda PWC dealer. If your dealer doesn't have the answer right away, they will get it for you.

If you have a difference of opinion with your dealer, please remember that each dealership is independently owned and operated. That's why it's important to work to resolve any differences at the dealership level.

If you wish to comment on your experiences with your Honda or with your Honda PWC dealer, please send your comments to the following address:

Motorcycle Division, American Honda Motor Co., Inc., P.O. Box 2220, Torrance, CA 90509-2220, mailstop: 100-4W-5B, telephone: (310) 532-9811.

Please include the following information in your letter.

- name, address, and telephone number
- Product model, year, and HIN serial number
- date of purchase
- dealer name and address

We will likely ask your Honda PWC dealer to respond, or possibly acknowledge your comments directly.

Your Honda PWC Dealer

Once you purchase your new Honda, get familiar with the organization of your Honda PWC dealer so you can utilize the full range of services available.

The service department is there to perform regular maintenance and unexpected repairs. It has the latest available service information from Honda. The service department will also handle warranty inspections and repairs.

The parts department offers Genuine Honda parts, Pro Honda products, Honda Genuine accessories. The same quality that went into your Honda can be found in Genuine Honda replacement parts. You'll also find comparable quality in the accessories and products available from the parts department.

The sales department offers the Honda Protection Plan to extend almost all of your warranty coverage. Your Honda PWC dealer can inform you about competition and other events in your area.

We're sure you'll be as pleased with the service your Honda PWC dealer continues to provide after the sale as you are with the quality and dependability of your Honda.

The Honda Rider's Club (USA only)

One of the best ways to get the most enjoyment from owning and riding your Honda is through the Honda Rider's Club of America. Your purchase of a new motorcycle, scooter, ATV or PWC from a participating U.S. Honda dealer entitles you to a complimentary one-year membership in the Club. There are hundreds of HRCA Chapter sponsoring dealers across the USA with events and activities almost every weekend. Membership benefits include:

- 24 hour, toll-free roadside assistance for your new Honda (includes roadside assistance for your transport vehicle as long as your Honda is aboard or in tow).
- Vehicle transport to the nearest Honda dealer or service center, if necessary.
- An exclusive HRCA website complete with access to the official Honda Common Service Manual, contests, insider information and more.

- Reimbursement (up to \$75) for Motorcycle Safety Foundation training. Separate free training from the Specialty Vehicle Institute of America for ATV owners.
- One full year of the *Honda Red Rider* magazine or *Honda Red Rider ATV* (for ATV purchasers).
- Discounts from HRCA partners for experienced rider courses.
- Discounted vehicle insurance from the HRCA's insurance partner.
- Racing contingency programs and assistance at selected dual-sport, off-road, and motocross events.

Contact your Honda dealer for more information or call: 1 800-847-HRCA or log on to www.hrca.honda.com.

Reporting Safety Defects (USA only)

If you believe that your vehicle has a defect which could cause a crash or could cause injury or death, you should immediately inform the U. S. Coast Guard (U.S.C.G.) in addition to notifying American Honda Motor Co., Inc.

If the U.S.C.G. receives similar complaints, it may open an investigation, and if it finds that a safety defect exists in a group of vehicles, it may order a recall and remedy campaign. However the U.S.C.G. cannot become involved in individual problems between you, your Honda PWC dealer, or American Honda Motor Co., Inc.

To contact the U. S. Coast Guard, write to:

Office of Boating Safety Product Assurance
Division-OPB-3
United States Coast Guard
2100 Second Street SW
Washington, DC 20593-0001

Table of Contents

The following presents the contents of each section of your owner's manual.

PWC SAFETY	1
Important Safety Information	2
Safety Labels	6
INSTRUMENTS & CONTROLS	11
Component Locations	13
Multi-function Display	19
SET Button	26
MODE Button	26
ID SET Button	27
ID No. Button	27
Low Oil Pressure Indicator	28
Engine Cooling Water Temperature Indicator	29
Low Battery Voltage Indicator	30
Fuel Gauge and Low Fuel Indicator	31
Digital Clock	32
Controls & Features	34
ID Lock System	34

Limit Mode	39
Start Button	40
Engine Stop Button/Switch	40
Safety Lanyard & Lock Clip	41
Handlebar	42
Throttle Lever	42
Trim Lever	43
Reverse Lever	45
Jet Pump Water Intake	46
Cooling Water Bypass Outlet	46
Bilge Drain Plugs	47
Flushing Connector	47
Jet Pump Steering Nozzle	48
Bow & Stern Eyelets	49
Grab Rail	50
BEFORE RIDING	51
Are You Ready to Ride?	52
Protective Apparel	52
Operator Training	55
Is Your PWC Ready to Ride?	56
Pre-ride Inspection	56

Table of Contents

Load Limits & Guidelines	61	Boarding with a Passenger	85
Load Limits	61	Your First Ride	87
Loading Guidelines	62	Turning	88
Cargo Compartments	63	Off-Throttle Steering (OTS)	90
Glove Box	63	Reverse Operation	91
Front Storage Compartment	64	Stopping/Docking/Beaching	93
Fire Extinguisher Compartment	66	Riding with a Passenger or Cargo	95
BASIC OPERATION & RIDING	67	Post-ride Maintenance	97
Safe Riding Precautions	68	SERVICING YOUR HONDA	99
PWC Propulsion	69	<i>Before You Service Your Honda</i>	
Navigation Rules	70	The Importance of Maintenance	102
Starting & Stopping the Engine	74	Maintenance Safety	103
Preparation	74	Important Safety Precautions	104
Starting Procedure	75	Maintenance Schedule	105
Flooded Engine	77	Maintenance Record	109
How to Stop the Engine	78		
Launching & Boarding Your PWC	80		
Launching from a Ramp	80		
Boarding from a Dock	81		
Boarding in Shallow Water	82		
Boarding in Deep Water	83		

Table of Contents

SERVICING YOUR HONDA (cont'd)

Service Preparations

Component Locations	110
Rear Cover Removal	113
Rear Tray Removal	114
Tool Kit	115
Owner's Manual Storage	116
Seat Removal	117

Service Procedures

Fluids, Filters & Lubricants

Fuel	119
Engine Oil & Filter	122
Air Filter	135
Lubrication	138

Engine

Throttle	145
Engine Idle Speed	148
Spark Plugs	149
Engine Cooling System	153

Hull

Bilge Drain System	157
--------------------------	-----

Steering & Propulsion System

Off-throttle Steering System	159
------------------------------------	-----

Electrical

Battery	161
---------------	-----

Appearance Care	166
-----------------------	-----

TIPS

Storing Your Honda	170
Transporting Your PWC	177
You & the Environment	178

Table of Contents

TAKING CARE OF THE UNEXPECTED	181
General Guidelines	182
If Your Engine Quits or Won't Start	183
If Your Engine Overheats	186
If the Low Oil Pressure Indicator Lights ..	187
If a Fuse Blows	188
If You Have a Collision	192
If Your PWC Must Be Towed	193
If You Capsize	194
If Your PWC Is Submerged	196
If the Intake or Propulsion System Is Clogged	198
If Your Battery Is Low (or Dead)	200
TECHNICAL INFORMATION	201
Vehicle Identification	202
Specifications	205
Break-in Guidelines	209
Emission Control Systems	210
Star Label	213
Oxygenated Fuels	216

CONSUMER INFORMATION	219
Authorized Manuals	220
Warranty Coverage	223
Warranty Service	224
Contacting Honda	225
Your Honda PWC Dealer	226
The Honda Rider's Club (USA only) ..	227
Reporting Safety Defects (USA only) ..	228

TABLE OF CONTENTS	230
--------------------------------	------------

INDEX	234
--------------------	------------

QUICK REFERENCE

Index

A

Air Filter	135
American Honda, contacting	225
apparel, protective	52
appearance care	166
authorized manuals	220

B

battery	161
beaching	94
bilge,	
drain plugs	47
drain system	157
boarding,	
from a dock	81
in deep water	83
in shallow water	82
with a passenger	85

break-in guidelines	209
button,	
ID No.	27
ID SET	27
MODE	26
SET	26

C

capacity, fuel	120
capsize, if you	194
care, appearance	166
color label	204
compartment,	
fire extinguisher	66
storage, front	64
tool kit	115
component locations,	
instruments and controls	13
maintenance	110
consumer information	219

cooling water bypass outlet 46
customer service 225

D

defects, safety 228
digital clock 32
display, multi-function 19
docking 94

E

emission control systems 214
engine,
 cooling system 153
 flooded 77
 idle speed 148
 low oil pressure 187
 number 203
 oil 124

overheats 186
start button 40
starting 74
stop button/switch 40
stopping 93
won't start 183
environment 178
eyelets, bow and stern 49

F

fire extinguisher compartment 66
flooded engine 77
flushing,
 connector 47
 procedure 154
fuel,
 oxygenated 216
 recommendation 119
 tank capacity 120
fuses 188

Index

G

gap, spark plug	152
gasohol	216
gasoline	119
gauge, fuel	31
glove box	63

H

Honda,	
contacting	225
dealer	226
Rider's Club	227
service manual	220

I

ID,	
lock system	34
No. button	27
SET button	27
identification, hull	206
idle speed, engine	148
indicator,	
engine cooling water temperature	22, 29
limit mode	22, 39
low battery voltage	21, 30
low fuel	25, 31
low oil pressure	22, 28
PGM-FI	23
inspection, pre-ride	56
intake/propulsion system, cleaning	198

J

- jet pump,
 - steering nozzle 48
 - water intake 46

K

- kit, tool 115

L

- labels, safety 6
- launching & boarding your PWC 80
- launching from a ramp 80
- limit mode 39
- limit, weight 61
- load limits 61
- loading guidelines 62

- locations, component,
 - instruments and controls 13
 - maintenance 110
- lubrication 138

M

- maintenance,
 - importance 102
 - post-ride 97
 - record 109
 - safety 103
 - schedule 105
- manual, service 220
- maximum weight limit 61
- multi-function,
 - display 19
 - meter 24

Index

N

- navigation rules 70
- numbers, serial 202

O

- off-throttle steering system 90
- oil,
 - engine 124
 - low pressure 22, 28
- operating controls 34
- overheat, engine 186
- owner's manual storage 116
- oxygenated fuels 216

P

- plugs, spark 149

- post-ride maintenance 97
- pre-ride inspection 56
- problems, unexpected 181
- propulsion, PWC 69
- protective apparel 52

R

- removal,
 - rear cover 113
 - rear tray 114
 - seat 117
- reporting safety defects 228
- reverse,
 - bucket 45
 - lever 45
 - operation 91
- ride, your first 87
- rider training 55
- Rider's Club, Honda 227

riding,	
basic operation	67
gear	53
safety	2
safety precautions	68
with a passenger and cargo	95
rules, navigation	70

S

safety lanyard	41
safety,	
important precautions	104
labels	6
reporting defects	228
riding precautions	68
schedule, maintenance	105
seat removal	117
serial numbers	202
service,	
customer	225

manuals	220
warranty	224
spark plugs	149
specifications	205
speedometer	25
star label	213
start button	40
starting,	
engine	74
troubleshooting	183
steering, off-throttle system	90
stop button/switch, engine	40
stopping	93
stopping engine	78
storage,	
compartment, front	64
owner's manual	116
personal watercraft	170
submerged, if your PWC is	196

Index

T

throttle lever	42
time meter	24
tool kit	115
training, rider	55
transporting your PWC	177
trim lever	43
tripmeter	24
troubleshooting, starting	183
turning	88

V

vehicle identification	202
----------------------------------	-----

W

warranty,	
coverage	223
extended	223
service	224
washing your PWC	167
PWC propulsion	69
weight limit	61

Y

your first ride	87
---------------------------	----

The following is a brief, but important collection of information you need to know about your Honda. You'll also find space to record important notes.

How To Avoid Costly Repairs

The engine of your Honda can be the most expensive component to repair. Proper maintenance, especially the use of the recommended fluids and filters, prevents premature wear and damage.

Frequent causes of costly repairs are:

- **Engine oil:** Check the level frequently. Make sure you're using the recommended oil.
- **Water cooling bypass outlet:** Check the outlet frequently to make sure nothing is clogging the engine's cooling system.

Quick Reference

- Bilge drain plugs: Check both plugs are secure before each ride to avoid possible engine damage from water (especially salt water) in the engine compartment.
- Jet pump water intake: Avoid debris such as sand, weeds, or rocks which can damage the propulsion system.
- Improper towing: Always tow your PWC in a forward direction with bow eyelet, at a slow speed (under 10 mph).

Record important information on the following page:

Quick Reference

Registration No.	
Hull Identification No.	
Engine Identification No.	
Color Label	
Owner's Name	
Address	
City/State	
Phone	
Dealer's Name	
Address	
City/State	
Phone	
Service Mgr.	

Quick Reference

Scheduled Maintenance	Initial: 10 hours Regular: every 100 hours or 6 month
Pre-ride Inspection	Check the following items each time before you ride (page 56) . Jet pump water intake, hull, bilge drain plugs, loose parts, latches, engine compartment, engine oil, fuel and oil leaks, bilge, reverse system, start check, fuel level, handlebar, throttle lever, lock clip
Fuel/Capacity	Unleaded premium gasoline, pump octane number 91 or higher 16.64 US gal (63.0 ℓ)
Engine Oil	API Service Classification SG or higher, except oils labeled as energy conserving on the API service label. SAE 10W-40, JASO 4T Standard MA or MB, Pro Honda GN4, HP4 or HP4M 4-stroke oil or equivalent
Maximum Weight Capacity	338 lbs (153.5 kg) rider, passenger, all cargo and accessories
Spark Plugs	standard: IMR9D-9H
Fuses	main: 30 A other: 5 A, 7.5 A