

2007 Infiniti G35 Sedan V6-3.5L (VQ35HR)

Vehicle » Engine, Cooling and Exhaust » Engine » Timing Chain » Service and Repair

TIMING CHAIN

Exploded View EM-48 (Part 1)

Exploded View

MFPCVD-0000000000554256

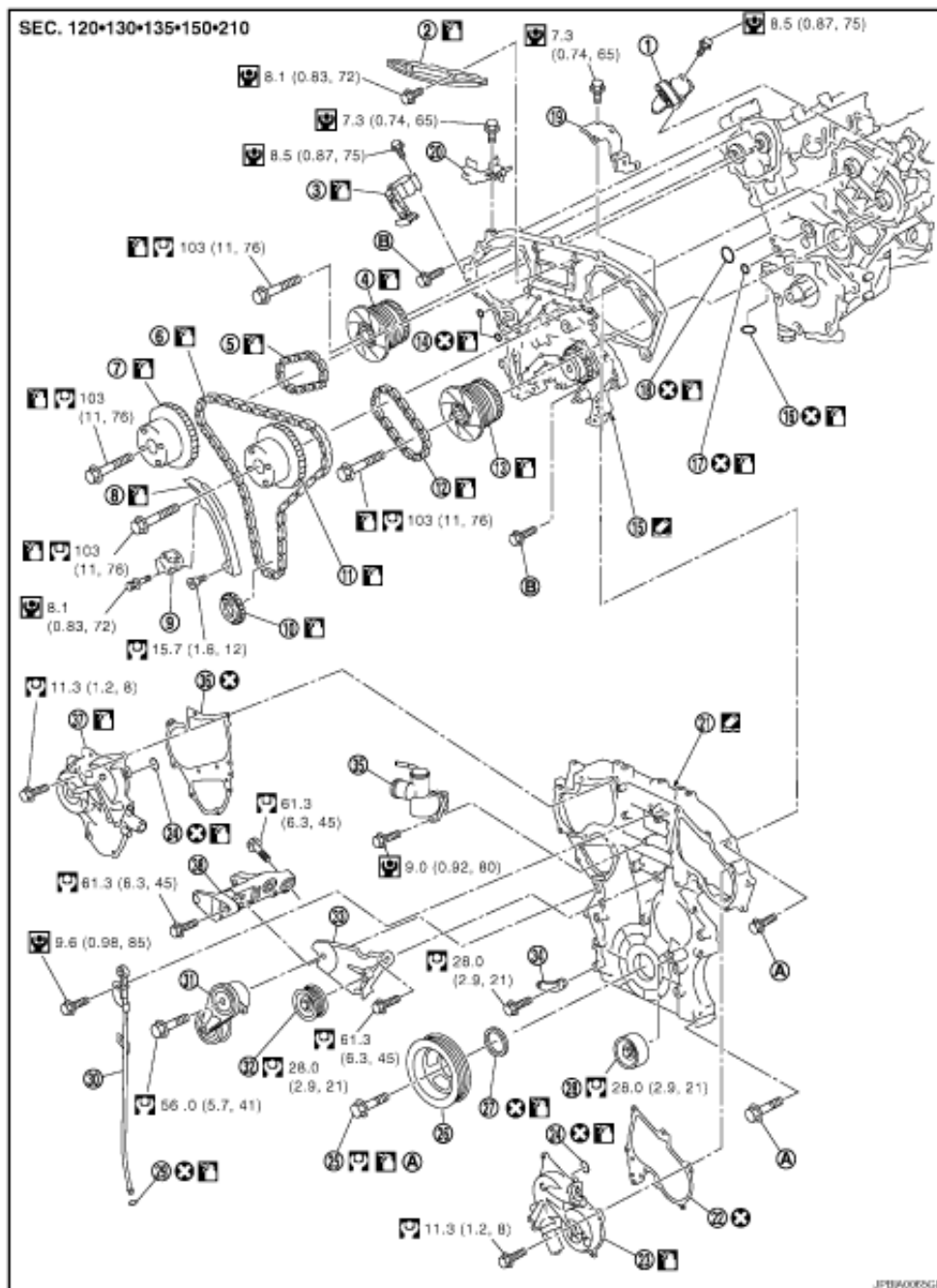

- | | | |
|---|-----------------------------|--|
| 1. Timing chain tensioner (secondary) (left bank) | 2. Internal chain guide | 3. Timing chain tensioner (secondary) (right bank) |
| 4. Camshaft sprocket (EXH) | 5. Timing chain (secondary) | 6. Timing chain (primary) |

Exploded View EM-48 (Part 2)

7. Camshaft sprocket (INT)	8. Slack guide	9. Timing chain tensioner (primary)
10. Crankshaft sprocket	11. Camshaft sprocket (INT)	12. Timing chain (secondary)
13. Camshaft sprocket (EXH)	14. O-ring	15. Rear timing chain case
16. O-ring	17. O-ring	18. O-ring
19. Bracket	20. Bracket	21. Front timing chain case
22. Valve timing control cover gasket (LH)	23. Valve timing control cover (LH)	24. O-ring
25. Crankshaft pulley bolt	26. Crankshaft pulley	27. Front oil seal
28. Idler pulley	29. O-ring	30. Oil level gauge guide
31. Drive belt auto-tensioner	32. Idler pulley	33. Idler pulley bracket
34. Alternator bracket	35. Water outlet (front)	36. Valve timing control cover gasket (RH)
37. Valve timing control cover (RH)		
A. Refer to EM-49	B. refer to EM-49	

[Refer to Diagram Information and Instruction for additional symbol definitions.](#)

Exploded View EM-65

Exploded View

NF/D0/0000000006259

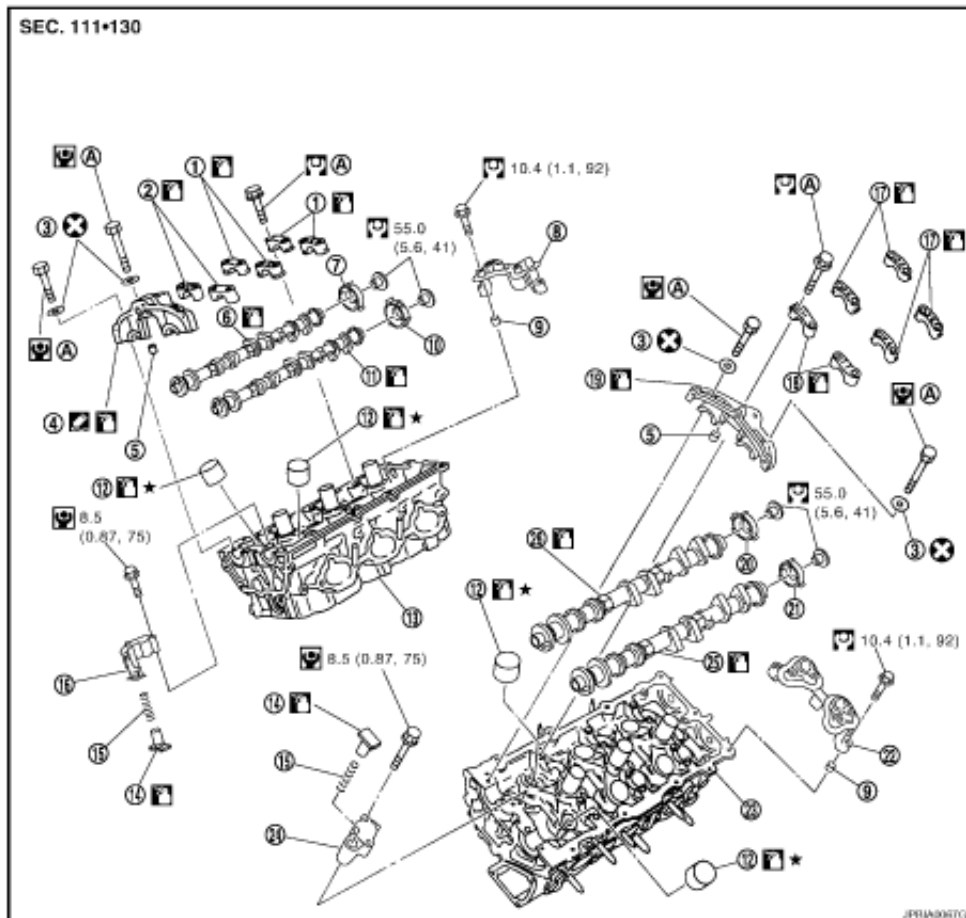

- | | | |
|---|---------------------------------|--|
| 1. Camshaft bracket (No. 3, 4) | 2. Camshaft bracket (No. 2) | 3. Seal washer |
| 4. Camshaft bracket (No. 1) | 5. Dowel pin | 6. Camshaft (EXH) (right bank) |
| 7. Camshaft signal plate (EXH) | 8. Camshaft sensor bracket | 9. Dowel pin |
| 10. Camshaft signal plate (INT) | 11. Camshaft (INT) (right bank) | 12. Valve lifter |
| 13. Cylinder head (right bank) | 14. Plunger | 15. Spring |
| 16. Timing chain tensioner (secondary) (right bank) | 17. Camshaft bracket (No. 3, 4) | 18. Camshaft bracket (No. 2) |
| 19. Camshaft bracket (No. 1) | 20. Camshaft signal plate (INT) | 21. Camshaft signal plate (EXH) |
| 22. Camshaft sensor bracket | 23. Cylinder head (left bank) | 24. Timing chain tensioner (secondary) (left bank) |
| 25. Camshaft (EXH) | 26. Camshaft (INT) | |

A. Refer to EM-65.

[Refer to Diagram Information and Instruction for additional symbol definitions](#)

Removal and Installation

REMOVAL

1. Release the [fuel pressure](#).
2. Disconnect the battery cable from the negative terminal.
3. Remove engine cover with power tool.
4. Remove [radiator](#) reservoir tank.

5. Remove air duct and air cleaner case assembly (RH and LH).
6. Remove engine undercover with power tool.
7. Drain engine coolant from radiator.

CAUTION:

- Perform this step when the engine is cold.
- Do not spill engine coolant on drive belts.

8. Remove radiator hose (upper and lower).
9. Drain engine oil.

CAUTION:

- Perform this step when the engine is cold.
- Do not spill engine oil on drive belts.

10. Remove radiator cooling fan assembly.
11. Remove drive belts.
12. Separate engine harnesses removing their brackets from front timing chain case.
13. Remove oil cooler tube (AWD models).
14. Remove intake manifold collector.
15. Remove fuel sub tube mounting bolt.
16. Remove oil level gauge and guide.
17. Remove A/C compressor from bracket with piping connected, and temporarily secure it aside.
18. Remove power steering oil pump from bracket with piping connected, and temporarily secure it aside.
19. Remove power steering oil pump bracket.
20. Remove idler pulley, auto tensioner and bracket.
21. Remove alternator and alternator bracket.
22. Remove water outlet and water piping.
23. Remove valve timing control covers (RH and LH) and gasket as follows:
 - a. Disconnect valve timing control harness connector.

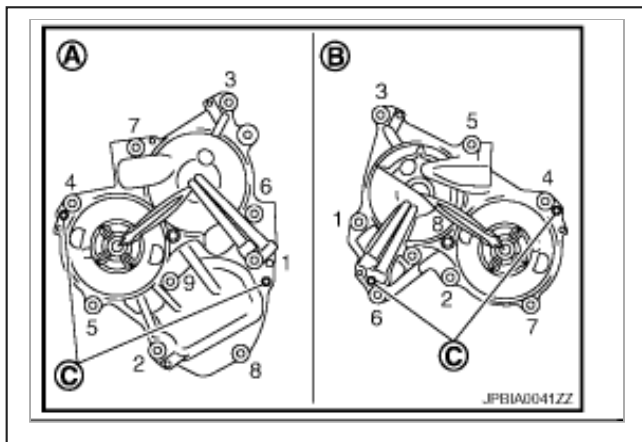

b. Loosen mounting bolts in reverse order as shown in the figure. A: Right bank

B: Left bank

C: Dowel pin hole

CAUTION: Shaft is internally jointed with camshaft sprocket (INT) center hole. When removing, keep it horizontal until it is completely disconnected.

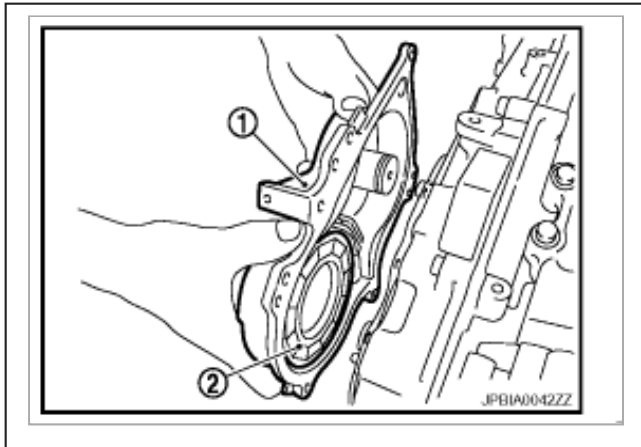

- c. Shaft is engaged with intake side camshaft sprocket center hole on inside. pull straight out so as not to tilt until the joint is disengaged.
- The mating surface of magnet retarder (2) may be fitted with the exhaust side camshaft sprocket via the engine oil. Open valve timing control cover (1) carefully
 - If the mating surface of magnet retarder is fitted with the camshaft sprocket, open the cover within the range that the load is not applied to the harness. And then, remove it so as to prevent magnet retarder from dropping.

CAUTION:

- **Be careful not to damage magnet retarder.**
- **When carrying valve timing control cover, face the magnet retarder side up to prevent the cover from falling from magnet retarder.**
- **Do not remove magnet retarder from valve timing control cover. (Disassembly prohibited parts)**

24. Remove rocker covers (right and left bank).

25. Obtain No.1 cylinder at TDC of its compression stroke as follows:

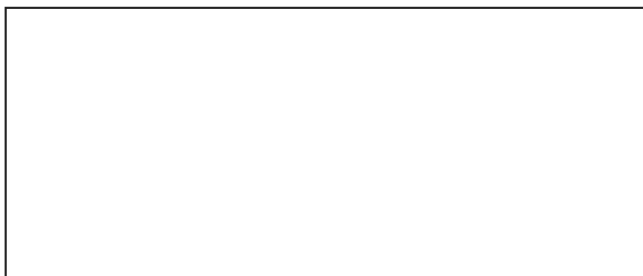

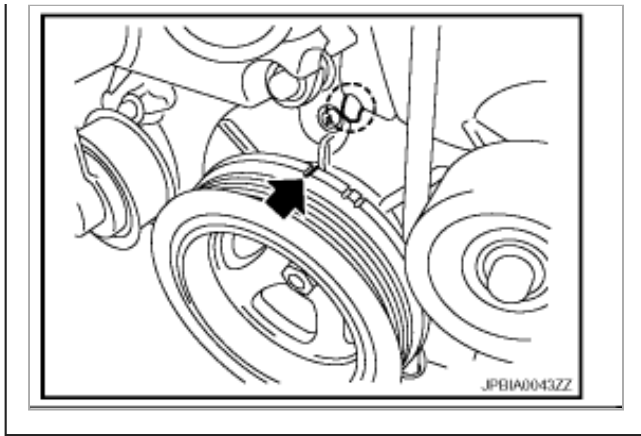

- a. Rotate crankshaft pulley clockwise to align timing mark (grooved line without color) with timing indicator.
Timing mark (grooved line without color)

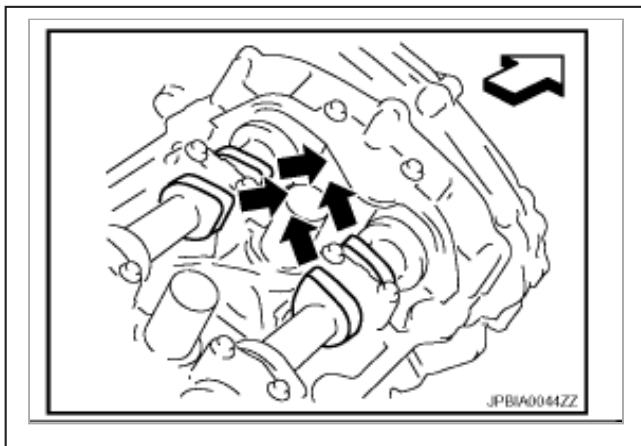

- b. Make sure that intake and exhaust cam noses on No.1 cylinder (engine front side of right bank) are located as shown in the figure.

- If not, turn **crankshaft one revolution (360 degrees)** and align as shown in the figure.

26. Remove crankshaft pulley as follows:

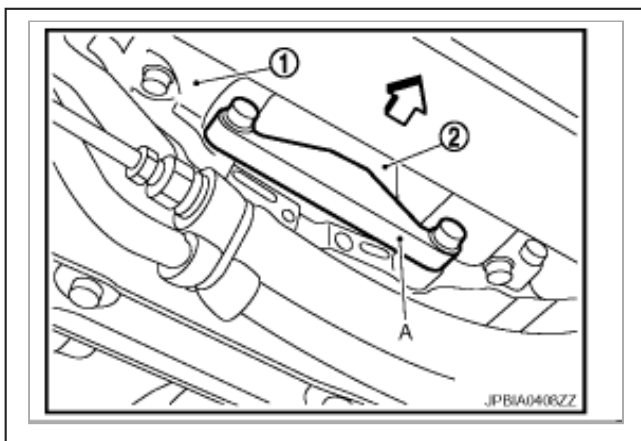

- a. Remove rear cover plate and set the ring gear stopper [SST: KV10118600 (J-48641)] (A) as shown in the figure. 1: Oil pan (upper)

2: Flywheel (M/T models) or driveplate (A/T models)

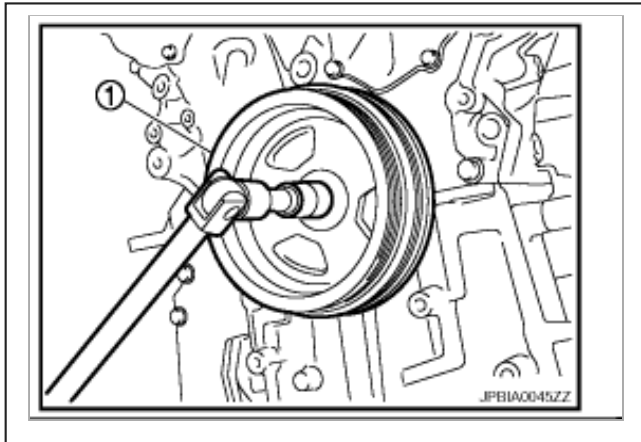

- b. Loosen crankshaft pulley bolt and rotate bolt seating surface at **10 mm (0.39 in)** from its original position. 1: Crankshaft pulley

CAUTION: Do not remove crankshaft pulley bolt as it will be used as a supporting point for suitable puller.

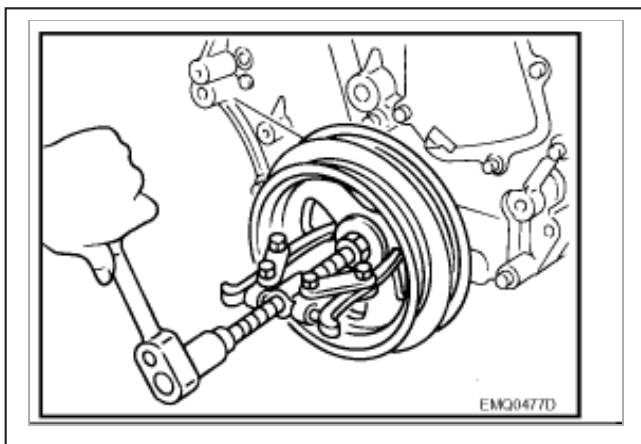

- c. Place suitable puller tab on holes of crankshaft pulley, and pull crankshaft pulley through.

CAUTION: Do not put suitable puller tab on crankshaft pulley periphery, as this will damage internal damper.

27. Remove **oil pan** (lower).

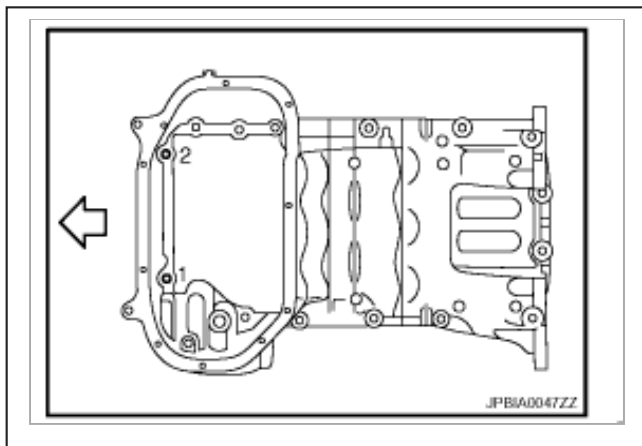

28. Loosen two mounting bolts in front of **oil pan** (upper) with power tool in reverse order as shown in the figure.

29. Remove front timing chain case as follows:

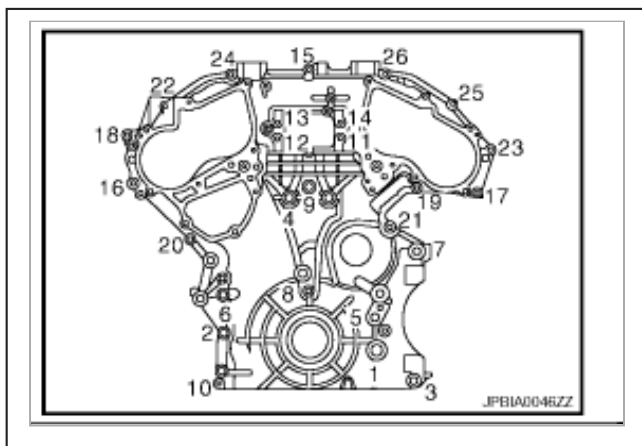

a. Loosen mounting bolts in reverse order as shown in the figure.

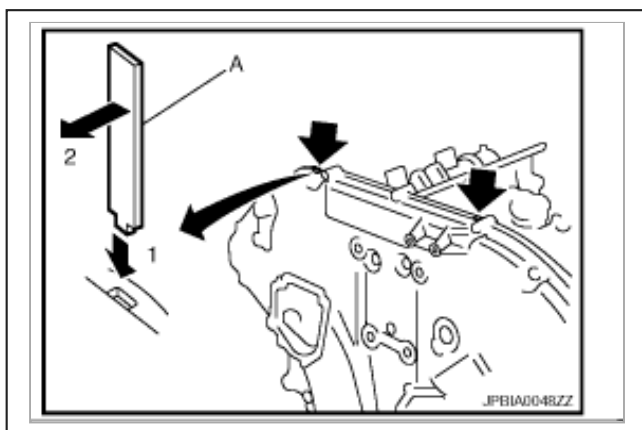

- b. Insert a suitable tool (A) into the notch at the top of front timing chain case as shown.
- c. Pry off case by moving the suitable tool as shown.
 - Use the seal cutter [SST: KV10111100 (J37228)] to cut liquid gasket for removal.

CAUTION:

- Do not use a screwdriver or something similar.
- After removal, handle front timing chain case carefully so it does not tilt, cant, or warp under a load.

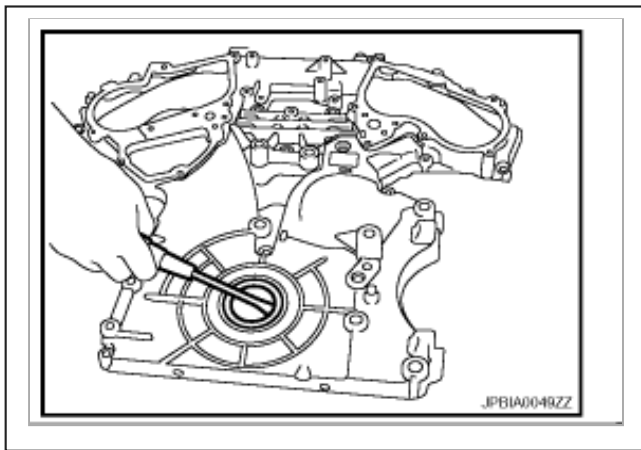

30. Remove front oil seal from front timing chain case using a suitable tool.

- Use a screwdriver for removal.

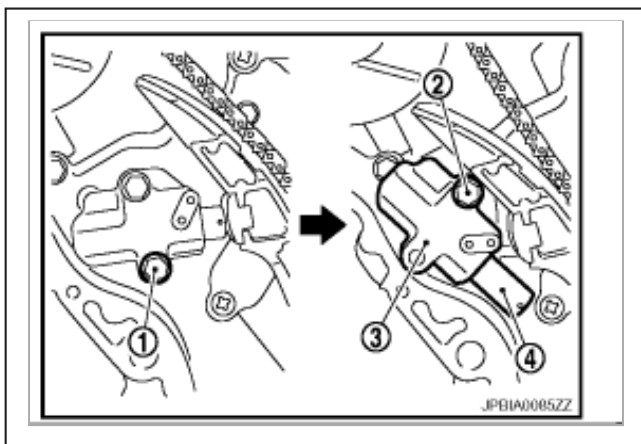
CAUTION: Be careful not to damage front timing chain case.

31. Remove **timing chain tensioner (primary)** as follows:

- a. Remove lower mounting bolt (1).
- b. Loosen upper mounting bolt (2) slowly, and then turn **timing chain tensioner (primary)** (3) on the upper mounting bolt so that plunger (4) is fully expanded.

NOTE: Even if plunger is fully expanded, it is not dropped from the body of **timing chain tensioner (primary)**.

- c. Remove upper mounting bolt, and then remove **timing chain tensioner (primary)**.

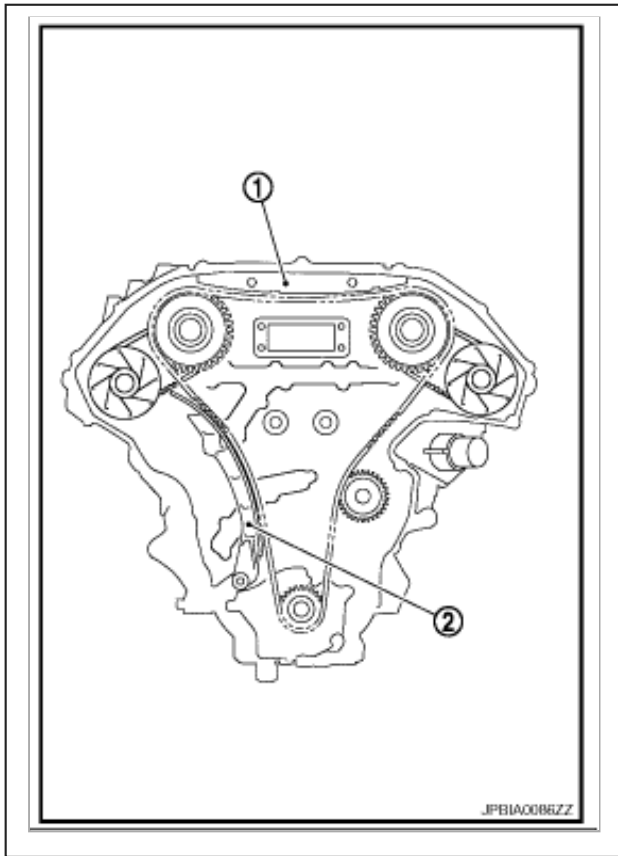

32. Remove internal chain guide (1), and slack guide (2).

33. Remove timing chain (primary) and crankshaft sprocket.

CAUTION: After removing **timing chain tensioner (primary)**, do not turn crankshaft and camshaft separately, or valves will strike the piston heads.

34. Remove timing chain (secondary) and camshaft sprockets as follows:



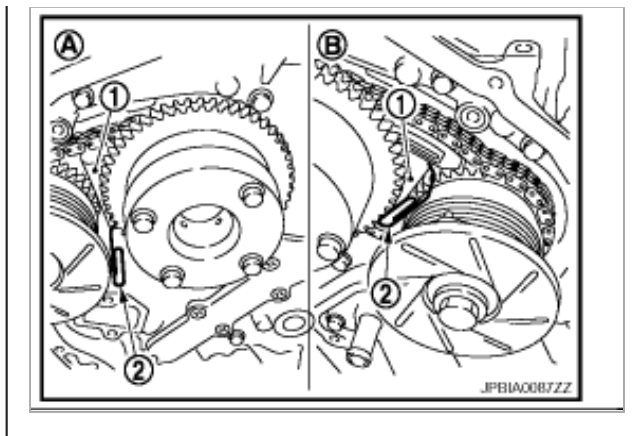

a. Attach suitable stopper pin (2) to the right and left **timing chain tensioners** (secondary) (1). A: Right bank

B: Left bank

NOTE:

- Use **approximately 0.5 mm (0.02 in)** dia. hard metal pin as a stopper pin.
- For removal of **timing chain tensioners** (secondary), refer to Exploded View EM-65. [Removing **camshaft bracket** (No.1) is required.]

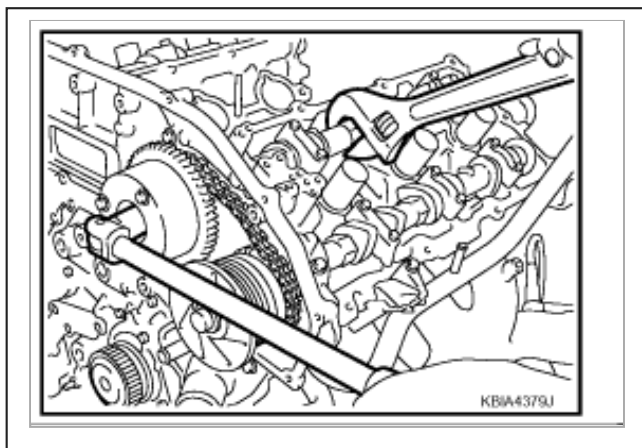

b. Remove camshaft sprocket mounting bolts (INT and EXH).

- Secure the hexagonal portion of **camshaft** using a wrench to loosen mounting bolts.

c. Remove timing chain (secondary) together with camshaft sprockets.

CAUTION:

- **Do not loosen the mounting bolts with securing anything other than the **camshaft** hexagonal portion or with tensioning the timing chain.**

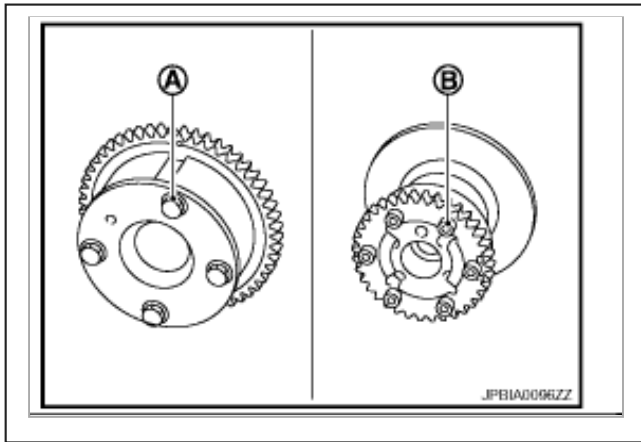

- **Do not disassemble. [Do not loosen bolts (A) and (B) as shown in the figure.]**

35. Remove **timing chain tensioners** (secondary) from cylinder head as follows, if necessary.
 - a. Remove **camshaft** brackets (No. 1).
 - b. Remove **timing chain tensioners** (secondary) with a stopper pin attached.

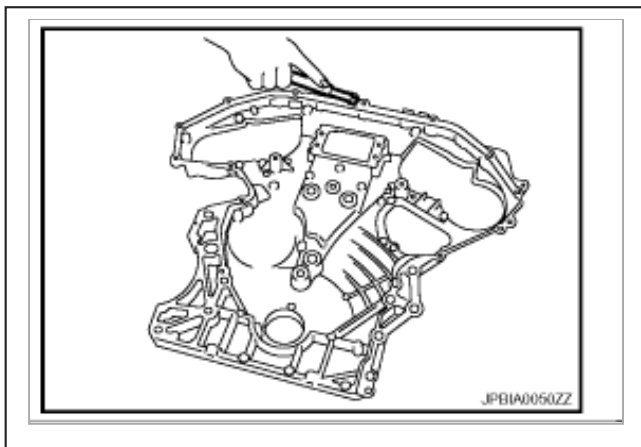

36. Use a scraper to remove all traces of old liquid gasket from front and rear timing chain cases and **oil pan** (upper), and liquid gasket mating surfaces.

CAUTION: Be careful not to allow gasket fragments to enter oil pan.



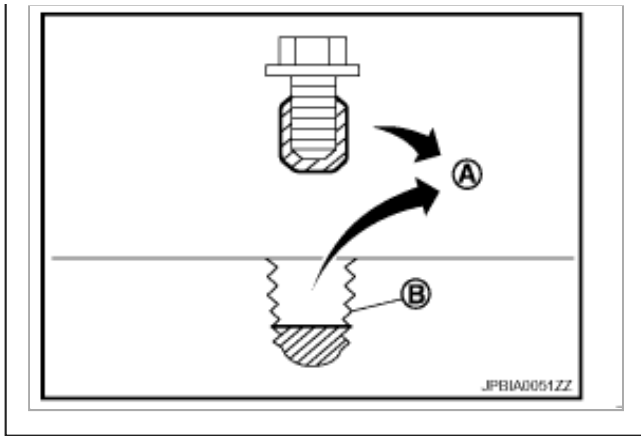

37. Remove old liquid gasket from bolt hole and thread. A: Remove sticking old liquid gasket

B: Bolt hole

INSTALLATION

NOTE: The below figure shows the relationship between the mating mark on each timing chain and that on the corresponding sprocket, with the components installed.

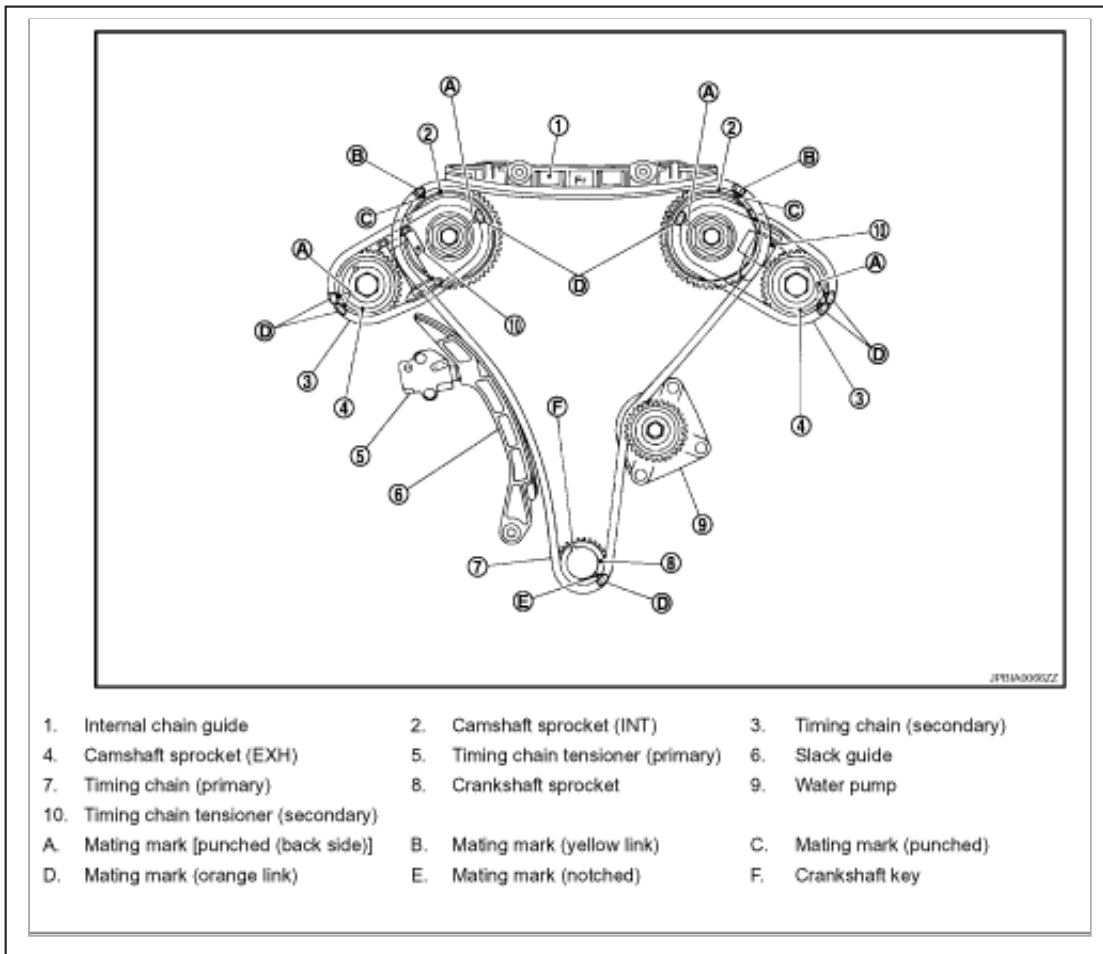

1. Install **timing chain tensioners** (secondary) to cylinder head as follows if removed. Refer to Exploded View EM-48.

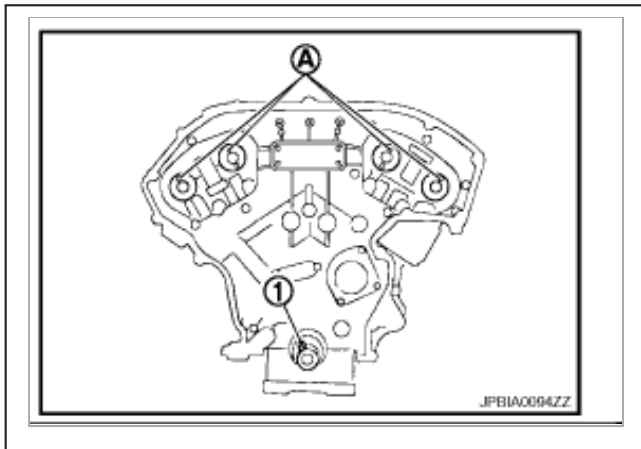

2. Make sure that dowel pin (A) and **crankshaft** key (1) are located as shown in the figure. (No. 1 cylinder at compression TDC)

NOTE: Though **camshaft** does not stop at the position as shown in the figure, for the placement of cam noses, it is generally accepted camshaft is placed for the same direction of the figure.

Camshaft dowel pin: At cylinder head upper face side in each bank.

Crankshaft key: At cylinder head side of right bank.

3. Install timing chains (secondary) and camshaft sprockets as follows:

CAUTION: Mating marks between timing chain and sprockets slip easily. Confirm all mating mark positions repeatedly during the installation process .

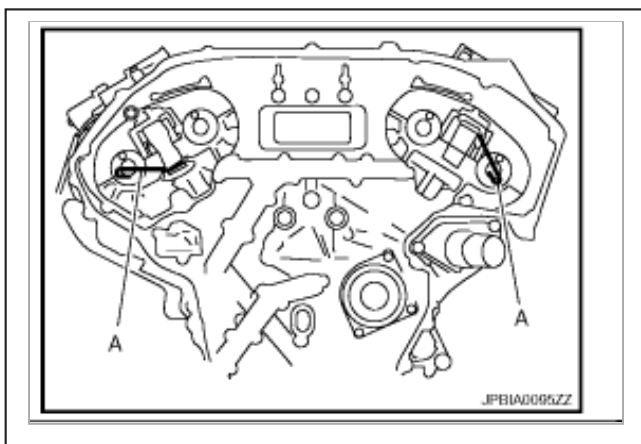

- a. Push plunger of **timing chain tensioner** (secondary) and keep it pressed in with a stopper pin (A).

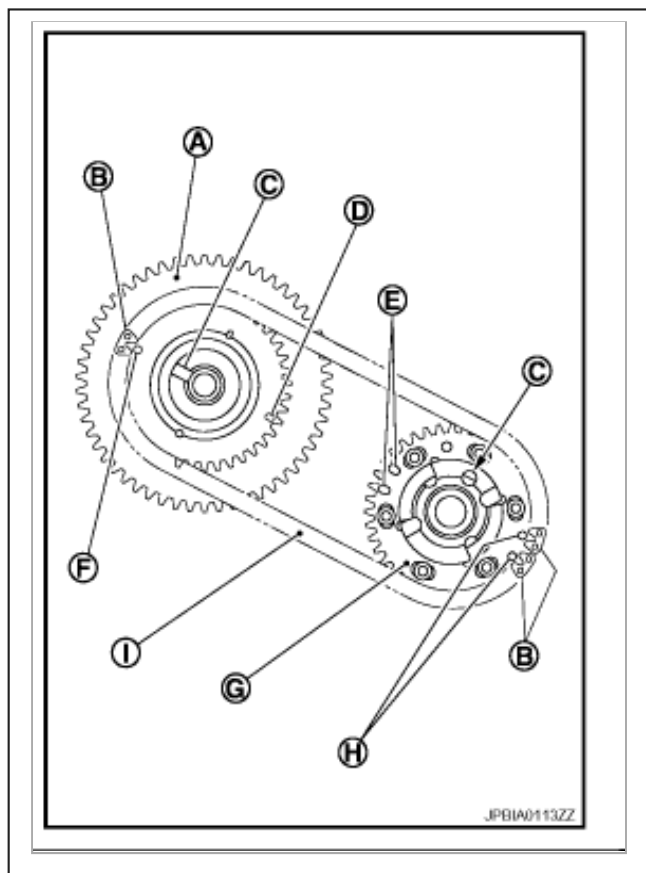

- b. Install timing chains (secondary) and camshaft sprockets. A: Camshaft sprocket (INT) back face

B: Orange link

C: Dowel groove or hole

D: Mating mark (Oval)

E: Mating mark (2 oval)

F: Mating mark (Circle)

G: Camshaft sprocket (EXH) back face

H: Mating mark (2 circle)

I: Timing chain (secondary)

- Align the mating marks on timing chain (secondary) (orange link) with the ones on intake and exhaust camshaft sprockets (punched), and install them.

NOTE:

- Mating marks for camshaft sprockets are on the back side of camshaft sprockets (secondary).
- There are two types of mating marks, circle and oval types. They should be used for the right and left banks, respectively. Right bank: Use circle type.

Left bank: Use oval type.

- Align dowel pin camshafts with the groove or dowel hole on sprockets, and install them.
- On the intake side, align dowel pin on **camshaft** front end with pin groove on the back side of camshaft sprocket, and install them.
- On the exhaust side, align dowel pin on **camshaft** front end with pin hole on camshaft sprocket, and install them.
- In case that positions of each mating mark and each dowel pin are not fit on mating parts, make fine adjustment to the position holding the hexagonal portion on **camshaft** with wrench or equivalent.
- Mounting bolts for camshaft sprockets must be tightened in the next step. Tightening them by hand is enough to prevent the dislocation of dowel pins.

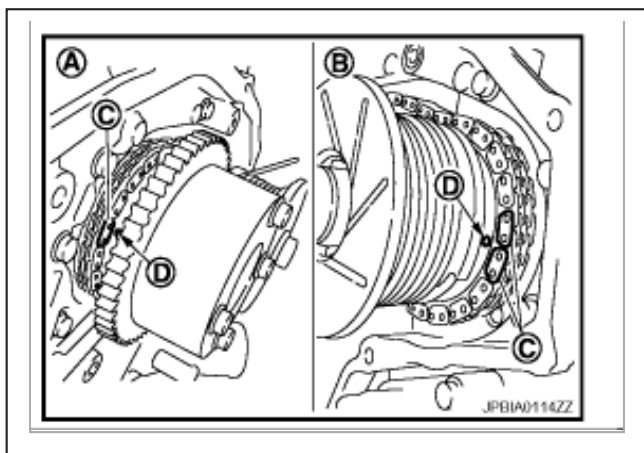

- Make sure the mating marks (punched) (D) on each camshaft sprocket are positioned on the mating marks (orange link) (C) on timing chain (secondary). A: Intake side

B: Exhaust side

NOTE: Mating mark (punched) in the figure is for checking loose at this step.

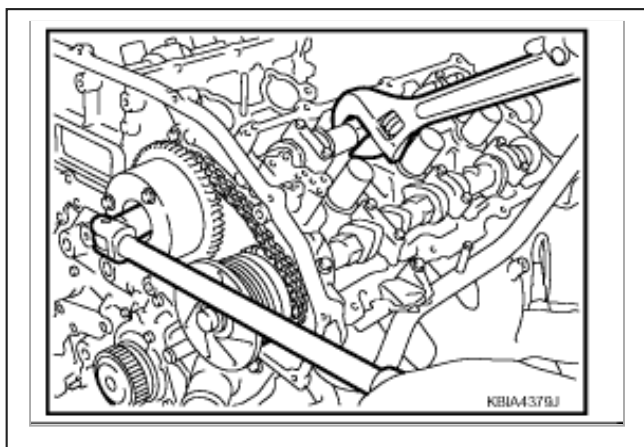

c. After confirming the mating marks are aligned, tighten camshaft sprocket mounting bolts.

- Secure **camshaft** using a wrench at the hexagonal portion to tighten mounting bolts.

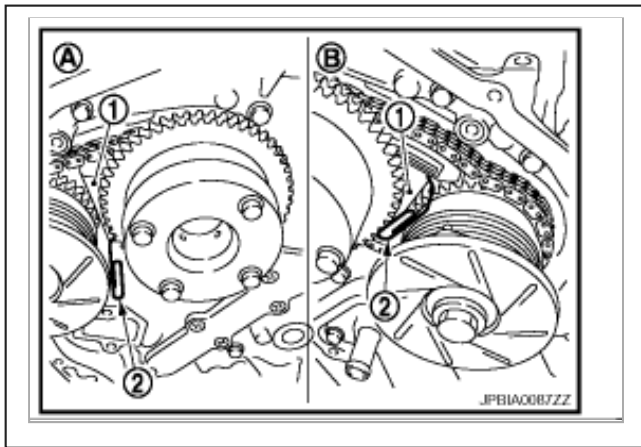

d. Pull stopper pins (2) out from **timing chain tensioners** (secondary) (1). A: Right bank

B: Left bank

4. Install timing chain (primary) as follows:

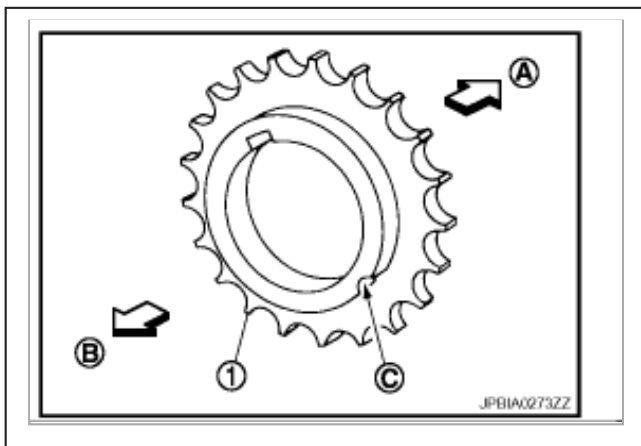

a. Install crankshaft sprocket (1). A: **Crankshaft** side

C: Mating mark (Front side)

- Make sure the mating marks on crankshaft sprocket face the front of the engine.

b. Install timing chain (primary).



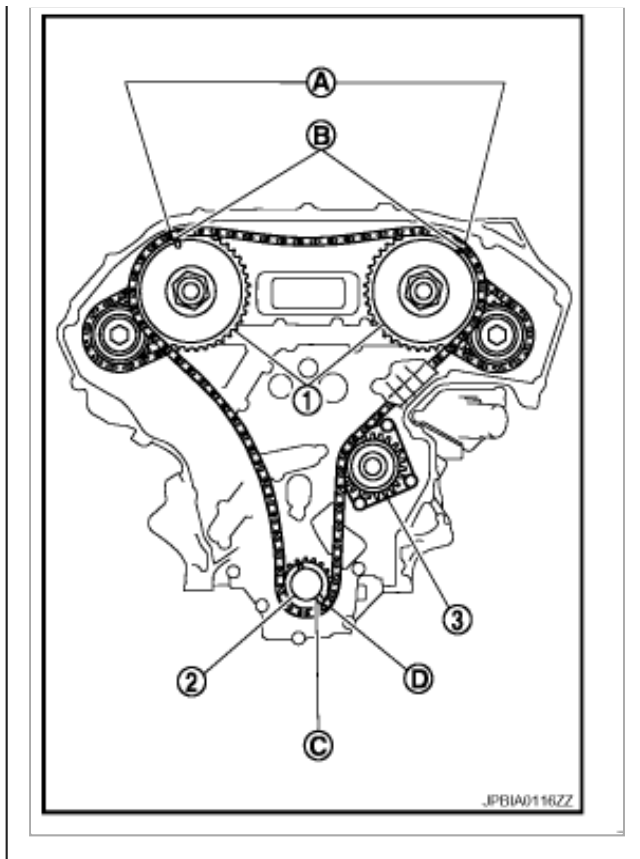

- Install timing chain (primary) so the mating mark (punched) (B) on camshaft sprocket (INT) (1) is aligned with the yellow link (A) on timing chain, while the mating mark (notched) (C) on crankshaft sprocket (2) is aligned with the orange link (D) one on timing chain, as shown in the figure. 3: [Water pump](#)
- When it is difficult to align mating marks of timing chain (primary) with each sprocket, gradually turn [camshaft](#) using wrench on the hexagonal portion to align it with the mating marks.
- During alignment, be careful to prevent dislocation of mating mark alignments of timing chains (secondary).

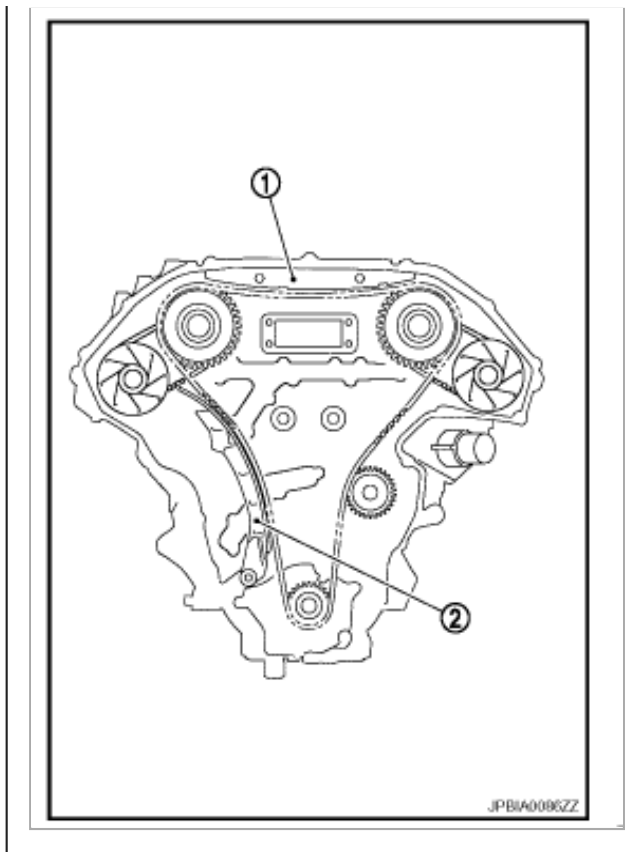

5. Install internal chain guide (1), slack guide (2) and [timing chain tensioner](#) (primary).

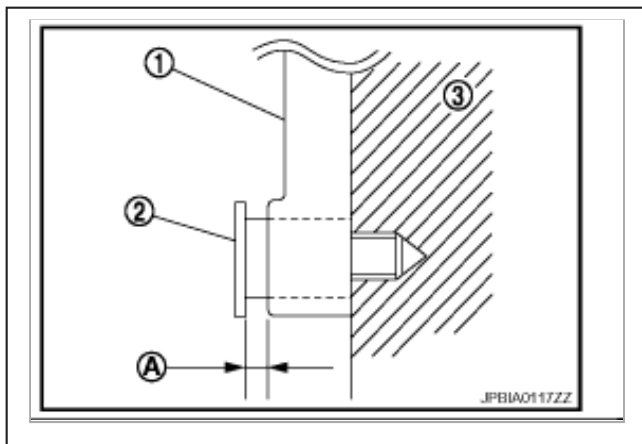

CAUTION: Do not overtighten slack guide mounting bolts (2). It is normal for a gap (A) to exist under the bolt seats when mounting bolts are tightened to the specification.

- 1: Slack guide
- 3: Cylinder block

6. Install the [timing chain tensioner](#) (primary) with the following procedure:

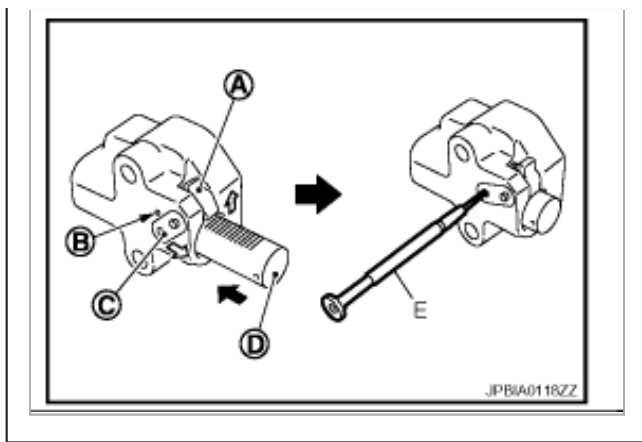

- a. Pull plunger stopper tab (A) up (or turn lever downward) so as to remove plunger stopper tab from the ratchet of plunger (D).

NOTE: Plunger stopper tab and lever (C) are synchronized.

- b. Push plunger into the inside of tensioner body.
 c. Hold plunger in the fully compressed position by engaging plunger stopper tab with the tip of ratchet.
 d. To secure lever, insert stopper pin (E) through hole of lever into tensioner body hole (B).
- The lever parts and the plunger stopper tab are synchronized. Therefore, the plunger will be secured under this condition.

NOTE: Figure shows the example of **1.2 mm (0.047 in)** diameter thin screwdriver being used as the stopper pin.

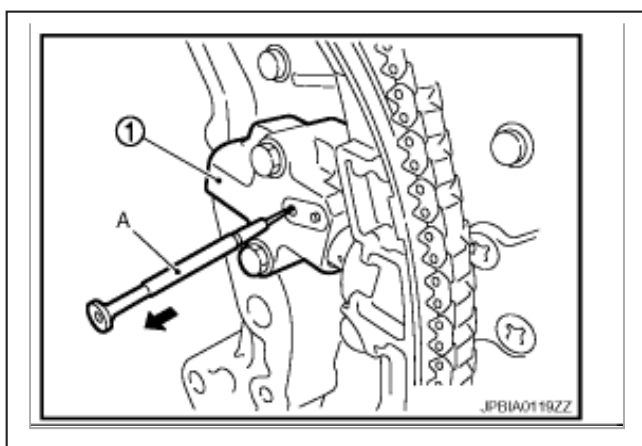

- e. Install **timing chain tensioner (primary)** (1).

- Remove any dirt and foreign materials completely from the back and the mounting surfaces of **timing chain tensioner (primary)**.

f. Pull out stopper pin (A) after installing, and then release plunger.

7. Make sure again that the mating marks on sprockets and timing chain have not slipped out of alignment.

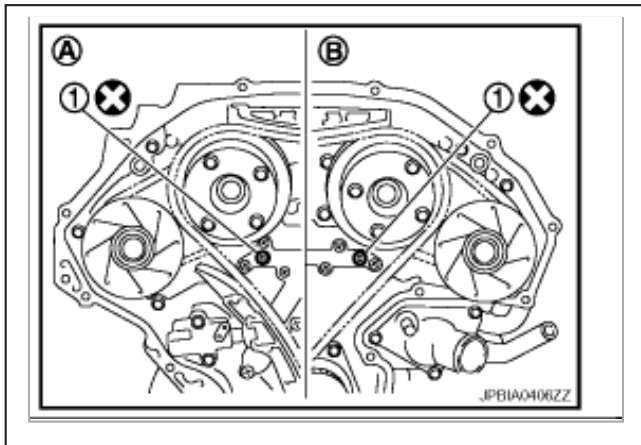

8. Install new O-rings (1) on rear timing chain case. A: Right bank

B: Left bank

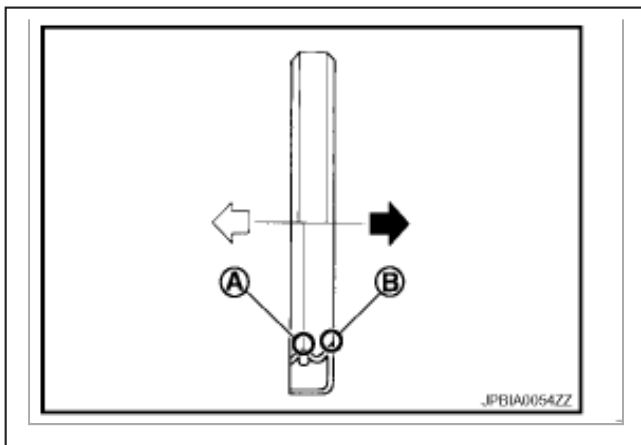

9. Install new front oil seal on front timing chain case. <-: Engine inside

<-: Engine outside

- Apply new engine oil to both oil seal lip (A) and dust seal lip (B).
- Install it so that each seal lip is oriented as shown in the figure.



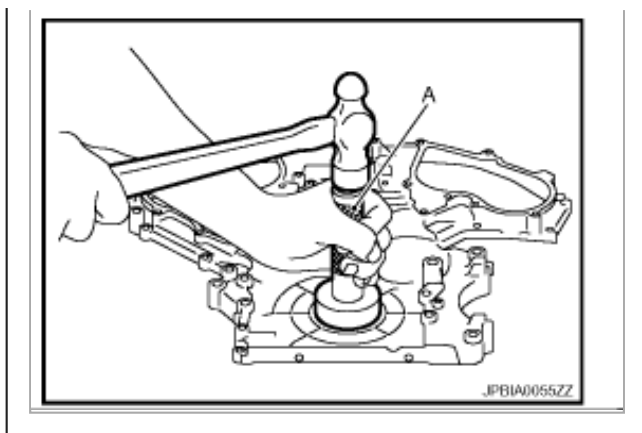

- Using a suitable drift [outer diameter: **60 mm (2.36 in)**] (A), press-fit oil seal until it becomes flush with front timing chain case end face.
- Make sure the garter spring is in position and seal lip is not inverted.

10. Install front timing chain case as follows:

- Make sure O-rings stay in place during installation to rear timing chain case.

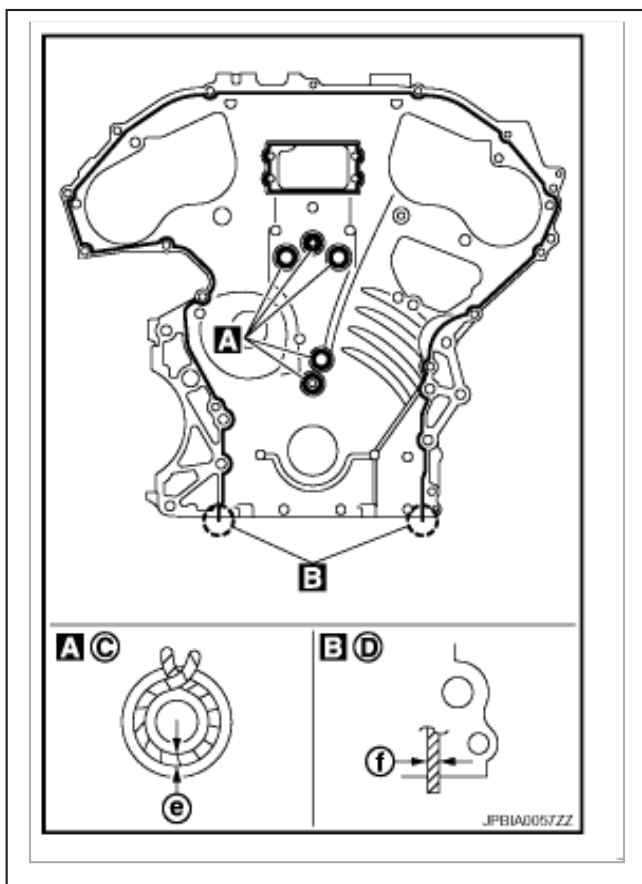

- a. Apply a continuous bead of liquid gasket with the tube presser [SST: WS39930000 (-)] to front timing chain case back side as shown in the figure. Use Genuine RTV Silicone Sealant or equivalent. Refer to

GI-15, "Recommended Chemical Products and Sealants". See: [Maintenance\Specifications\Fluid Types](#)

C: Bolt hole

D: Protrusion

e: **2.6 - 3.6 mm (0.102 - 0.142 in) dia.**

f: **3.4 - 4.4 mm (0.134 - 0.173 in) dia.**

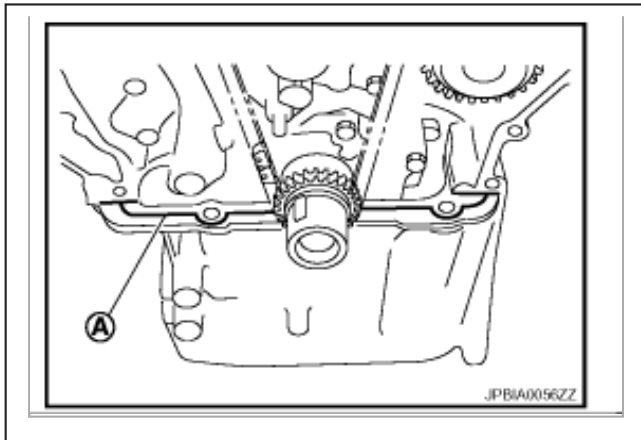

- b. Apply liquid gasket to top surface of **oil pan** (upper) as shown in the figure. A: **4.0 - 5.0 mm (0.157 - 0.197 in) dia.**

Use Genuine RTV silicone Sealant or equivalent. Refer to GI-15, "Recommended Chemical Products and Sealants". See: [Maintenance\Specifications\Fluid Types](#)

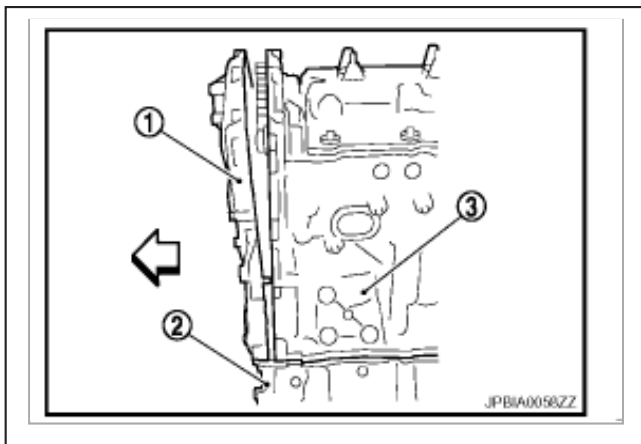

- c. Assemble front timing chain case. 1: Front timing chain case

2: **Oil pan** (upper)

3: Cylinder block

CAUTION:

- Be careful not to damage front oil seal by interference with front end of **crankshaft**.
- Attaching should be done within 5 minutes after liquid gasket application.

d. Install front timing chain case as to fit its dowel pin hole together dowel pin on rear timing chain case.

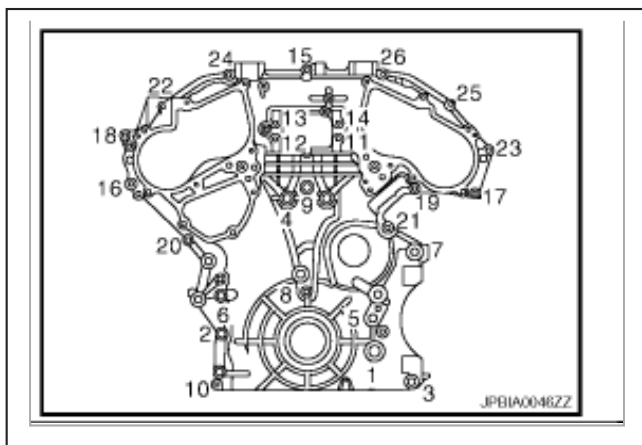

e. Tighten mounting bolts to the specified torque in numerical order as shown in the figure.

- There are two types of mounting bolts. Refer to the following for locating bolts. M10 bolts: 1, 2, 3, 4, 5, 6, 7: **55.0 Nm (5.6 kg-m, 41 ft-lb)**

M6 bolts: Except the above: **12.7 Nm (1.3 kg-m, 9 ft-lb)**

f. After all bolts are tightened, retighten them to the specified torque in numerical order shown in the figure.

CAUTION: Be sure to wipe off any excessive liquid gasket leaking on surface mating with oil pan (upper).

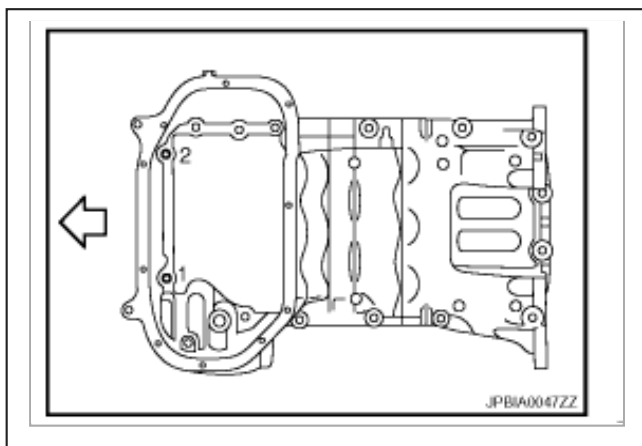

g. Install two mounting bolts in front of **oil pan** (upper) in numerical order shown in the figure.

11. Install right and left valve timing control covers as follows:

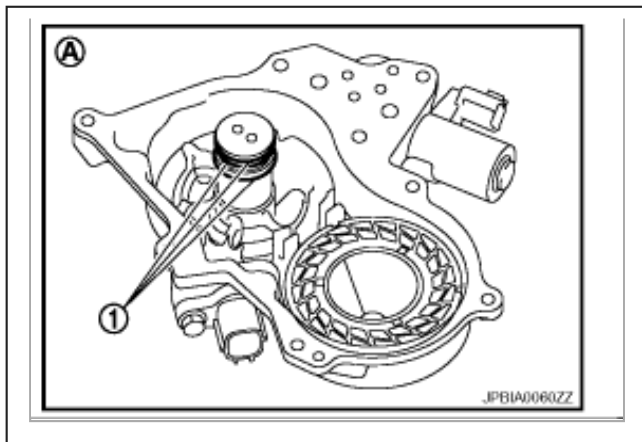

a. Install new seal rings (1) in shaft grooves. A: Left bank

CAUTION: When replacing seal ring, replace all rings with new one.

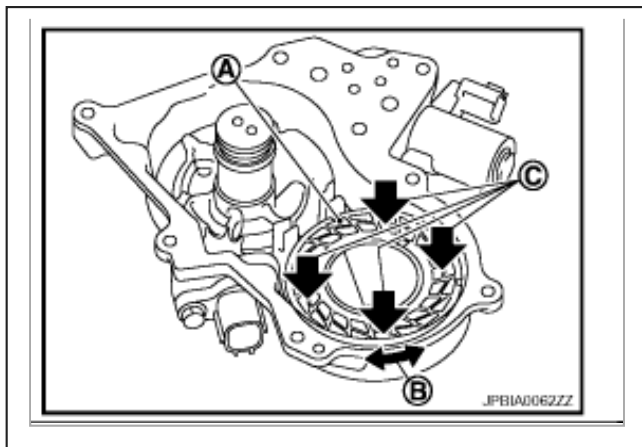

b. To check the joint between dowel pins and dowel pin holes, check the looseness in the axle direction by pushing the circumferential looseness (between dowel pins and dowel pin holes) by twisting in the circumferential direction.

CAUTION: Always perform this procedure when removing because the gap between dowel pins and dowel pin holes may not be caused on purpose.

A: Mating surface of magnet retarder

B: Moves slightly

C: Not shaken

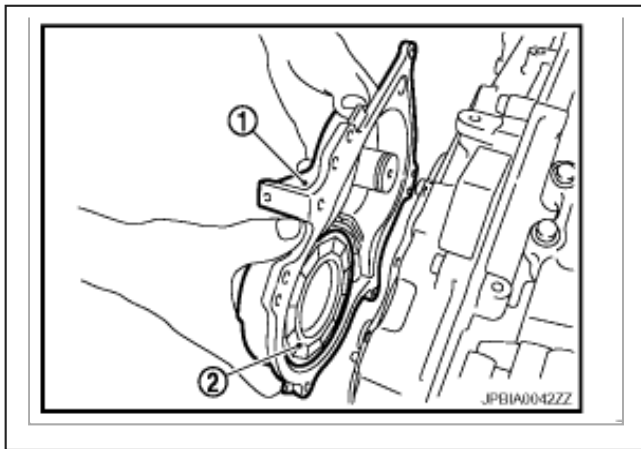

c. Install valve timing control cover with new gasket to front timing chain case. 1: Valve timing control cover

2: Magnet retarder

CAUTION:

- Do not face the magnet retarder side down to prevent magnet retarder from dropping.
- Check the mating surface of magnet retarder and the drum of exhaust side camshaft sprocket for foreign materials.
- Align the center of both shaft holes of the shaft and the intake side camshaft sprocket, and then insert them.
- Be careful not to drop the seal ring from the shaft groove.
- When setting the valve timing control cover in position by hand, if valve timing control cover is not contacting with the front timing chain case, the dowel pin of magnet retarder may not be aligned with the dowel pin holes of cover. In this case, return to step "b".

d. Being careful not to move seal ring from the installation groove, align dowel pins on front timing chain case with holes to install valve timing control covers.

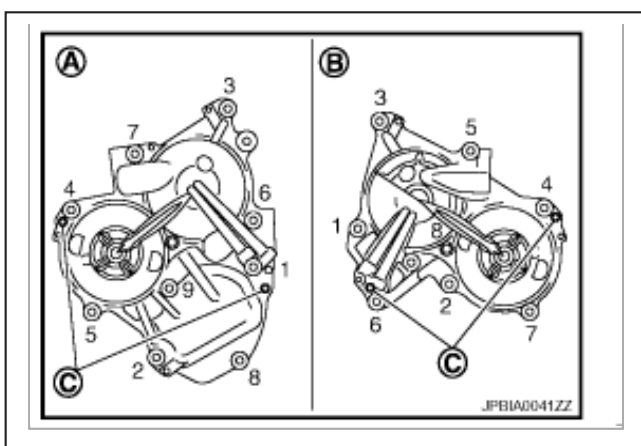

e. Tighten mounting bolts in numerical order as shown in the figure. A: Right bank

B: Left bank

C: Dowel pin hole

- After all bolts are tightened, tighten No.1 bolt to the specified torque again.

12. Install **oil pan** (lower).

13. Install rocker covers (right and left banks).

14. Install crankshaft pulley as follows:

- Fix **crankshaft** using the ring gear stopper [SST: KV10118600 (J-48641)].
- Install crankshaft pulley, taking care not to damage front oil seal.

- When press-fitting crankshaft pulley with plastic hammer, tap on its center portion (not circumference).

c. Tighten crankshaft pulley bolt. Torque: **44.1 Nm (4.5 kg-m, 33 ft-lb)**

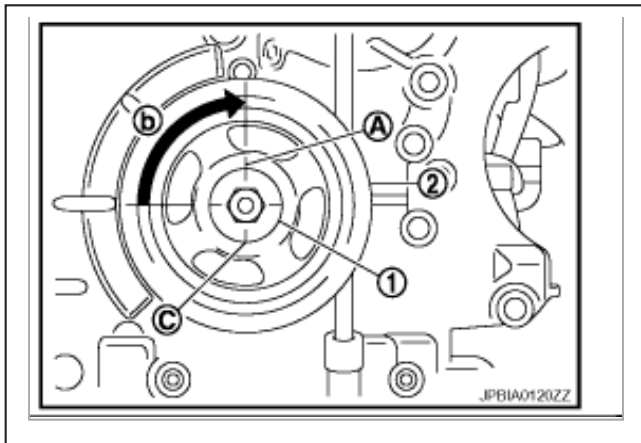

- Place a matching mark (A) on crankshaft pulley (2) aligning with the matching (C) of crankshaft pulley bolt (1). Tighten the bolt **90°** (one marks) (b).
- Rotate crankshaft pulley in normal direction (clockwise when viewed from front) to confirm it turns smoothly.

15. For the following operations, perform steps in the reverse order of removal.

Inspection

INSPECTION AFTER REMOVAL

Timing Chain

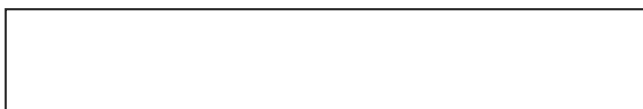

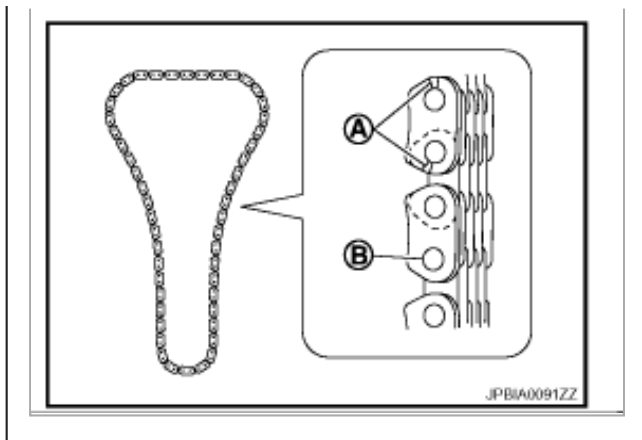

Check for cracks and any excessive wear at link plates and roller links of timing chain. Replace timing chain as necessary.

A: Crack

B: Wear

INSPECTION AFTER INSTALLATION

Inspection for Leaks

The following are procedures for checking fluids leak, lubricates leak.

- Before starting engine, check oil/fluid levels including engine coolant and engine oil. If less than required quantity, fill to the specified level. Refer to GI-15, "Recommended Chemical Products and Sealants". See: [Maintenance\Specifications\Fluid Types](#)
- Use procedure below to check for fuel leakage.
- Turn ignition switch "ON" (with engine stopped). With [fuel pressure](#) applied to fuel piping, check for fuel leakage at connection points.
- Start engine. With engine speed increased, check again for fuel leakage at connection points.
- Run engine to check for unusual noise and vibration.

NOTE: If hydraulic pressure inside chain tensioner drops after removal/installation, slack in guide may generate a pounding noise during and just after the engine start. However, this does not indicate an unusualness. Noise will stop after hydraulic pressure rises.

- Warm up engine thoroughly to make sure there is no leakage of fuel, or any oil/fluids including engine oil and engine coolant.
- Bleed air from lines and hoses of applicable lines, such as in [cooling system](#).
- After cooling down engine, again check oil/fluid levels including engine oil and engine coolant. Refill to the specified level, if necessary.

Summary of the inspection items

Summary of the inspection items:

Items	Before starting engine	Engine running	After engine stopped
Engine coolant	Level	Leakage	Level
Engine oil	Level	Leakage	Level
Other oils and fluid*	Level	Leakage	Level
Fuel	Leakage	Leakage	Leakage

* Transmission/transaxle/CVT fluid, power steering fluid, brake fluid, etc.