

# Technical BULLETIN

©2007 YAMAHA MOTOR CORPORATION, U.S.A.

## ALL RHINO 660 (YXR660) and RHINO 450 (YXR450) MODELS Doors, Additional Passenger Handholds, and Label



### INTRODUCTION

While the Rhino has been a reliable and versatile vehicle, some operators have engaged in abrupt maneuvers (such as turning the steering wheel too far or too fast) or aggressive driving (such as sliding, skidding, fishtailing, or doing donuts) that have resulted in side rollovers – even on flat, open areas. Unfortunately, some occupants have been seriously injured during such rollovers when they put their arms or legs outside the vehicle, resulting in crushing or other injuries.

Yamaha has developed new doors and additional passenger handholds for the Rhino. These new features are designed to help keep occupants from sticking arms or legs out of the vehicle in response to a side rollover. They may also enhance passenger stability and comfort. To promote awareness of the new free product features and to help reinforce safe and responsible use of the Rhino, Yamaha has also developed a label to put on the dashboard in the vehicle.

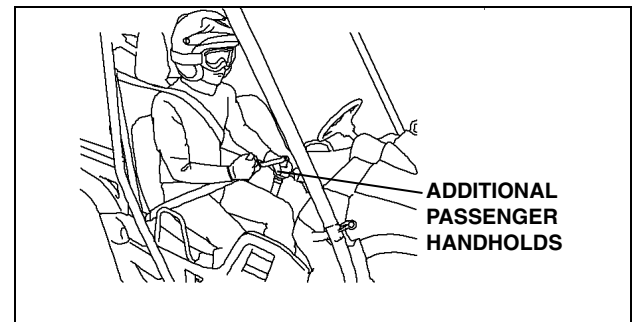
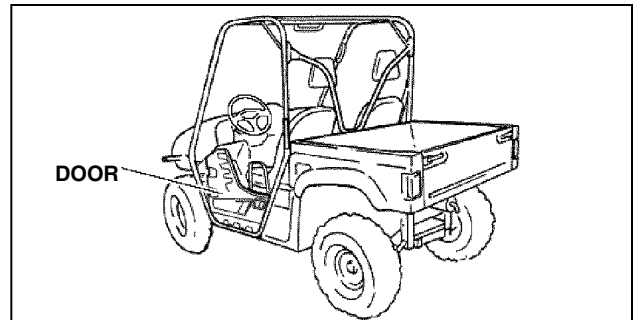

These features must be installed, before the units are delivered, on any 2004 through 2007 Rhino models in dealer inventory now or acquired in the future (whether new or used), that do not have them. This bulletin explains the installation procedure.

These features are also available to be installed by the dealer at no charge as an option to an owner of any Rhino vehicle that does not have them. Yamaha recommends that all owners of Rhinos have these features installed.

Yamaha is sending a letter to all registered owners of affected Rhino models offering these new features. A copy of the letter is attached. The letter includes an adhesive version of the label (the one in the kit is a riveted type) and a supplementary owner's manual pamphlet, the **Guide to Genuine Yamaha Doors/Handholds and Rhino Occupant Protection**.



## DEALER ACTION SUMMARY

### **Unsold**

**Units:** Install the door/handhold kits on any unit in your inventory or that you receive in the future that does not have them, regardless of model year.

### **Sold**

**Units:** The Rhino Door Kit is available to be installed by your dealership on any Rhino model, regardless of ownership or model year, if the owner requests it. As this is optional on sold units; do not install this kit without the owner's express permission.

**NOTE:** This program will not cover work to return modified units to stock condition. If a unit has welded racing bars or other modifications that prohibit normal installation, the unit must be returned to stock condition at customer expense before the doors, additional handgrip, or label can be installed. If installation of the full kit is not possible because of modifications to the vehicle, make note of the vehicle's condition in your service files for future reference.

### **Used**

**Units:** Install the Rhino Door Kit on any unit in your used inventory that does not have them, regardless of model year. See the note above regarding modified units, if applicable.

### **Parts**

**Required:** Yes. The Rhino Door Kit contains the doors, the additional passenger handhold assembly, and a new main label. Kits are in stock and available for immediate order; see the Parts Information section of this bulletin.

**NOTE:** Yamaha has begun auto-shipping enough Rhino Door Kits to cover the number of unregistered units Yamaha records show you had in your inventory on 8/15/2007 (up to a maximum of 20 kits; you can see how many kits were ordered for you on YDS). Use these initial kits as needed. You can use them to modify units ready for sale or for a customer who contacts you regarding installation of the kit. Please give priority to customer-owned units.

### **Notify**

**Customers:** Yes. Yamaha has sent a letter to all registered owners of affected units. You should also offer the free Door/Handhold Kit to the owner of any Rhino model that does not have them. You do not need the letter from Yamaha to modify a unit, but you will need the customer's permission, as the doors and handholds are optional features on customer-owned units.

**Warranty:** Service-per-bulletin (90UC). See the Warranty Information section of this bulletin.



## AFFECTED RANGE

All 2004 YXR660

All 2005 YXR660

All 2006 YXR660

All 2006 YXR450

All 2007 YXR660 without doors

All 2007 YXR450 without doors



## SERVICE PROCEDURES

### Special Tools/Supplies Required

- 8mm Hex Tamper Resistant bit or TORX® T-50 Tamper Resistant bit
- Rotary cut off tool or jig saw
- Rivet gun
- Masking tape
- 3mm (1/8") drill bit
- 5mm (13/64") drill bit
- 10mm (25/64") drill bit
- 12.5mm (1/2") drill bit
- Blue Loctite® 242

### Preparation

Place vehicle on a level surface and set the parking brake. Clean all mounting surfaces before beginning installation.

#### **CAUTION:**

**Put masking tape on frame tubes to prevent damage to the finish while drilling holes.**

### Door Installation (left side shown)

1. Use a 5mm (13/64") bit to drill out the two rivets located on lower frame tube on each side (see Fig. 1).
2. Using the rivet holes as an index, drill through the frame tube with a 10mm (25/64") drill bit. Keep the drill bit as perpendicular to the frame tube as possible.
3. Enlarge the holes on the door side of the frame (toward the rear of the vehicle) with a 12.5mm (1/2") drill bit or a step drill bit. Do not drill through the holes on the other side; they remain 10mm (25/64") (see Fig. 2).
4. Insert door hinge mounting studs in the holes. Secure the door hinge in place using curved washers and bolts from the opposite side of tube (see Fig. 3). Using an 8mm Hex Tamper Resistant bit or TORX® T-50 Tamper Resistant bit, apply Blue Loctite® 242 to the threads and tighten the bolts to specification.

**Hinge Mounting Bolt Tightening Torque:  
23 Nm (2.3 m • kg, 16.9 ft • lb)**

5. Repeat the procedure for the other side.



### Latch Striker Plate Installation (left side shown)

1. Remove the adhesive backing and place the left-hand template from the kit on the side panel below the seat. Be sure the template is aligned properly with top and front edges, then press down firmly (see Fig. 4)
2. Remove the plastic rivets securing the side panel and remove the panel.
3. Cut out the rectangular opening for the latch striker plate. Drill 10mm (25/64") hole in each corner and then use a rotary tool or a jig saw to complete the cutout. Remove any burrs and smooth the cutout edges for a clean appearance.
4. Reinstall the side panel.
5. Hold the latch striker plate in place as shown in Fig. 5. Center it to the steel square tubing and the cut out of the side panel and mark the two holes. Center-punch the marks.
6. Drill the two holes into the steel support square tubing with a 5mm (13/64") drill bit. Drill into the outside surface of the square tubing only. Do not drill completely through the tubing.

#### **⚠ WARNING**

**The fuel tank is behind the right side panel. Do not drill or cut into fuel tank. Leaking fuel is a fire hazard.**

7. Install the door latch striker plate using two short self-tapping 6mm bolts provided in kit (see Fig. 5). Apply Blue Loctite® 242 to the threads and tighten to specification. Do not over-tighten.

#### **Latch Striker Bolt Tightening Torque: 8 Nm (0.8 m • kg, 5.9 ft • lb)**

8. Operate door to be sure it latches securely.
9. Repeat procedure for the other side using the right-hand adhesive template from the kit.

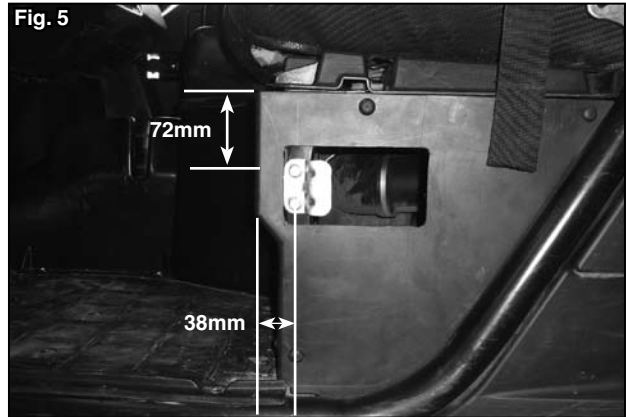

### Grip Assist Assembly Installation

1. Remove passenger seat assembly.
2. Place seat upside down on a level surface.
3. Insert Grip Assist Assembly into the side of seat and secure with four self-tapping 6mm bolts and four step washers provided. Apply Blue Loctite® 242 to the threads and tighten to specification. Do not over-tighten (see Fig 6).

### Grip Assembly Mounting Bolt Tightening Torque:

**8 Nm (0.8 m • kg, 5.9 ft • lb)**

4. Reinstall the passenger seat (see Fig. 7).

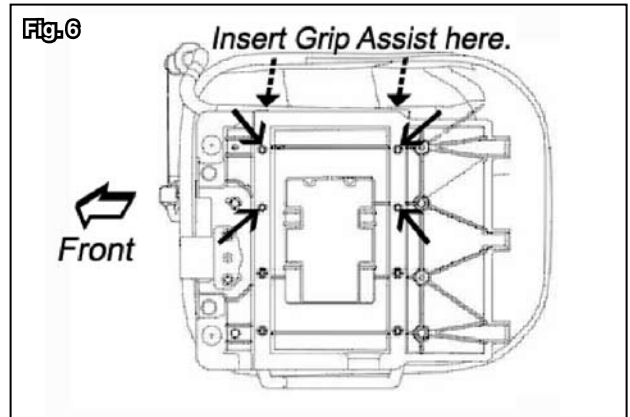

### Warning Label Installation

1. Use a 3mm (1/8") drill bit to drill out the four rivets holding the existing label in place (see Fig. 8).

2. Remove the original label.

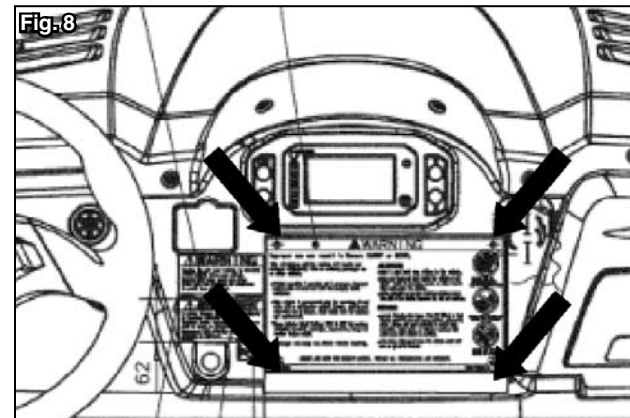

3. Remove the adhesive backing and attach new label in place, keeping the rivet holes aligned. Secure the label with rivets/washers provided in kit (see Fig. 9).

4. Tag and hold the original label for 90 days from the date you submit your warranty request.

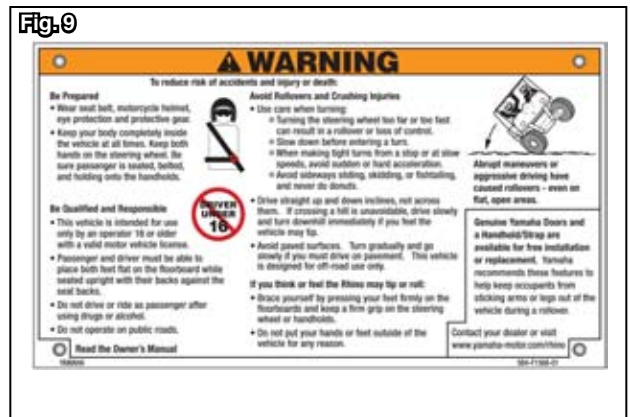

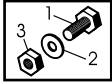

## PARTS INFORMATION

**NOTE:** Yamaha has auto-shipped enough Door/Handhold kits to cover the number of unregistered units Yamaha records show you had in your inventory on 8/15/2007 (up to a maximum of 20 kits; you can see how many kits were ordered for you on YDS). Use these initial kits as needed. You can use them to modify units ready for sale or for a customer who contacts you regarding installation of the kit. Please give priority to customer-owned units.

Part Number	Description	Remarks	Dealer Cost
SSV-5B4DR-KT-00	Rhino Door Kit	Kit Contents: <ul style="list-style-type: none"><li>• Door (left side), qty. 1</li><li>• Door (right side), qty 1</li><li>• Curved Washer, qty. 4</li><li>• Door Hinge Bolts (Hex), qty. 4</li><li>• Door Latch Striker Plates, qty. 2</li><li>• Striker Plate Bolts (short, 6mm), qty. 4</li><li>• Grip Assist Assembly, qty. 1</li><li>• Grip Assist Bolts (6mm), qty. 4</li><li>• Step Washers, qty. 4</li><li>• Warning Label, qty. 1</li><li>• Rivets, qty. 4</li><li>• Rivet washers, qty 4</li><li>• Template</li></ul>	\$130.00



## WARRANTY INFORMATION

This product update is authorized for any Rhino unit that does not have genuine Yamaha doors, additional passenger handholds, and the new warning label, regardless of ownership or warranty status.

To receive credit for parts and labor for the modification after completion, select **090UC** from the Problem Code pull down menu in the Yamaha Dealer System (YDS). If submitting a paper warranty claim, use Problem Code **90UC**. The labor allowance for this modification is **1.0 hour**.

Hold the replaced label for 90 days from the date you submit your Warranty Request.



**YAMAHA MOTOR CORPORATION, U.S.A.**

6555 Katella Avenue • Cypress • California • 90630-5101 • (714) 761-7300 • Fax (714) 761-7303

August 27, 2007

Dear Yamaha Rhino Owner:

This letter contains important information about your Yamaha Rhino.

While the Rhino has been a reliable and versatile vehicle, some operators have engaged in aggressive driving (such as sliding, skidding, fishtailing, or doing donuts) or made abrupt maneuvers (such as turning the steering wheel too far or too fast) that have resulted in side rollovers – even on flat, open areas. Unfortunately, some occupants have been seriously injured during such roll-overs when they put their arms or legs outside the vehicle, resulting in crushing or other injuries.

**Special Offer to Rhino Owners**

Yamaha has developed new doors and additional passenger handholds for the Rhino. These new features, as shown in the enclosed guide, are designed to help keep occupants from sticking arms or legs out of the vehicle in response to a side rollover. They may also enhance passenger stability and comfort. You can find more information at [www.yamaha-motor.com/rhino](http://www.yamaha-motor.com/rhino). Yamaha recommends that you have these doors and handholds installed on your Rhino.



**ADDITIONAL PASSENGER HANDHOLDS**

**All Rhino Owners Can Have These New Features Installed Free of Charge.**

Please make an appointment with your Yamaha dealer to take advantage of this special offer.

You may be aware that a number of aftermarket companies are now offering doors, panels, bars, netting, or similar products for installation on Rhinos. Yamaha cannot investigate or endorse aftermarket companies' products with respect to quality, fit, or safety. We only recommend genuine Yamaha parts and accessories for your Rhino.

**Put This New On-Product Label on Your Rhino**

To promote awareness of the new free product features and to help reinforce safe and responsible use of the Rhino, Yamaha has developed the enclosed adhesive label. Please read it and follow the instructions below to put it on your vehicle.

**Guide to Genuine Yamaha Doors/Handholds and Rhino Occupant Protection**

To help you understand how these new features fit into the overall approach to Rhino occupant safety, please read the enclosed guide. Please put this letter and the enclosed guide with your owner's manual for future reference and pass it on to a future owner.

Thank you for giving your attention to this important matter.

Sincerely,

Customer Support Group  
Yamaha Motor Corporation, U.S.A.