

Drive-Alert

Vehicle Detection Systems

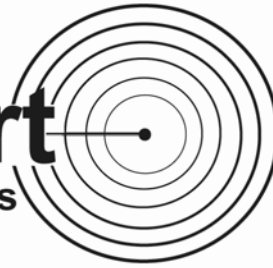

WIRELESS VEHICLE DETECTION AT ITS BEST!!!

To download a full-color manual, or for information on our other products, please visit:

www.mierproducts.com

2009

WIRELESS DRIVE-ALERT INSTALLATION AND OPERATION MANUAL

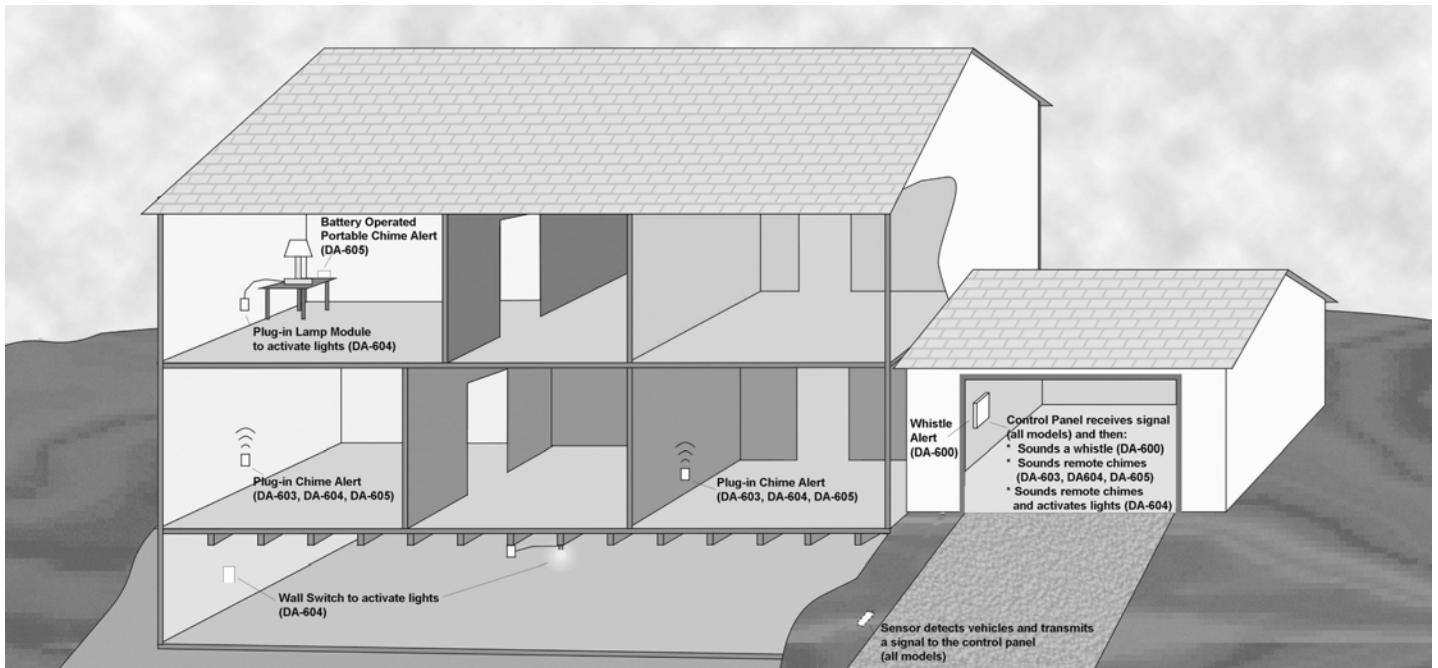

www.mierproducts.com

Wireless Vehicle Detection * Driveway Alarms * Drive-Up Window Detection * Buried Sensor Systems * Instrument Boxes * DVR Lockboxes Rack-Mount Lockboxes * CPU/DVR Tower Lockboxes * Flush-Mount Cabinets * Outdoor Enclosures * Temperature Controlled Enclosures Power Supply Boxes Siren/Speaker Cabinets * Bell Boxes * Battery Cabinets * Transformer Enclosures * Custom Enclosures & Fabrication

TABLE OF CONTENTS

<u>Page</u>	<u>Content</u>
	Cover Page
1	Table of contents
2	Introduction to the Wireless Drive-Alert Family of Systems
3	Wireless Drive-Alert Accessories
4	ALL MODELS - Sensor/Transmitter (DA-610) Installation
5	ALL MODELS - Wireless Sensor/Transmitter (DA-610) Installation <i>continued</i>
6	Model DA-600 General Information
7	Model DA-600 Installation and Terminals
8	Model DA-600 Application Drawings (activating other components)
9	Model DA-600 and DA-610 Sensor Specifications
10	Model DA-603 General Information and Installation
11	Model DA-604 General Information and Installation
12	Model DA-605 General Information and Installation
13	Warranty and FCC/Radio Frequency Information
<hr/>	
	Addendum Table of Contents
A1	<i>QUICK-START</i> Installation Guide
A2-A4	FAQs (Frequently Asked Questions) and Troubleshooting Guide
B	DA-655 Chime with Volume Control General Information and Installation
C	DA-611 Remote Transmitter and Sensor w/ cable General Info and Installation
D	DA-660 Long Range Booster Antenna General Information and Installation
E	DA-066 Remote Chime Transmitter General Information and Installation
F	DA-067 Antenna Stabilizer General Information and Installation
G	DA-ROCK1 Discreet Sensor Cover

INTRODUCTION TO THE WIRELESS DRIVE-ALERT FAMILY OF SYSTEMS

The Mier Products' Wireless Drive-Alert Detection Systems integrate Mier's proven DA-500 wired detection technology with the benefit of economical wireless installation while maintaining the features most sought by customers.

A Mier Wireless System includes 3 components:

1. Receiver
2. Sensor/Transmitter and
3. Sound Annunciator or control

Mier's Wireless Receiver family includes the

- **DA-600** containing an internal piezoelectric sounder **OR** use of Form C Dry Contacts like the DA-500.
- **DA-603** with one integrated X10 Power Flash to transmit to multiple X10 Chimes like the DA-503.
- **DA-604** with two integrated X10 Power Flashes and timer function to transmit to multiple X10 Chimes and Light components like the DA-504.
- Featuring the **New DA-605** with integrated "line of sight" transmission to multiple plug-in chimes and battery powered portable chimes that include volume and tone selection.

All Mier Wireless Receiver models feature

- 110 volt AC plug-in.
- +24 volt DC power source for use with accessories.
- Relay output available for use by accessories or control (Form C Dry Contacts only available on DA-600)
- Visible POWER LED to monitor power status and LO BATT LED to monitor transmitter batteries.
- User accessible address switches to set a unique address code between it and the transmitter if required.
- Normal reception to 1000 feet or ½ mile if using to the DA-660 Booster Antenna (see Addendum D).
- Use of an unlimited number of Mier Wireless Transmitters by a Receiver.
- 100% compatibility with the Mier DA-610 and optional DA-611 Sensor/transmitters.
- Compatible with Mier Accessories detailed in this manual (See page 3)

The DA-610 and optional DA-611 Sensor/Transmitter models feature

- Complete portability
- Operation on 2-AA (LR6) Alkaline or Rechargeable Batteries.
- Included circuitry to detect and transmit a low battery condition to the Receiver.
- A durable, lockable, standard brick size, weather sealed steel housing with mounting brackets.
- Detection of any disturbance in earth's magnetic field (e.g. moving vehicles) and not people, animals & etc.
- Sensor detection through standard building materials.

EASY INSTALLATION!



AS EASY AS 1, 2, 3 ...

1. Install 2 - AA batteries in the Sensor/Transmitter, turn it on and place it in the area you wish to monitor.
2. Set up the Receiver 4-6 feet above ground inside the home/building and plug it in.
3. Test the installation using a vehicle or other moving metal. Then, mount the control panel when performance is satisfactory

NOTE: All installations can be easily tested by plugging in the Receiver and turning on the Sensor/Transmitter which will send a radio signal to the Receiver for about one minute and the sounder or control will respond.

IN MANY INSTANCES, THIS CAN BE COMPLETED IN UNDER 30 MINUTES TIME!!!

WIRELESS DRIVE-ALERT ACCESSORIES

WIRELESS DRIVE-ALERT ACCESSORIES:



1. The **DA-655 Chime with Volume Control** – is our most popular accessory for the model DA-600 Drive-Alert, and is perfect for **Drive-up Window Applications!**
2. The **DA-505 Timer Control** – is used to with the DA-600 to turn on lights when the sensor detects a vehicle. The DA-604 model activates lights as a standard feature.
3. The **DA-052 Whistle with Volume Boost** – is used with the DA-600 when a second whistle is desired (hard-wired installation)
4. The **DA-057 Power-Flash** is used with the DA-600 in combination with the **DA-058 Remote Chime** OR the **DA-066 Remote Chime Transmitter** in combination with the **DA-068 Remote Chime** OR the **DA-066 Remote Chime Transmitter in combination with the DA-070 Battery-operated Portable Chime** are used together in applications where an alarm is desired in more rooms/areas of a home, building or property. An easier way to do this is to install a Drive-Alert model with these features as standard (see the easy to install DA-603, DA-605, or DA-604 for applications where alarms and/or lights are needed in multiple rooms/areas)
5. The **DA-067 Antenna Stabilizer** is used with the DA-610 or DA-611 Sensors to prevent transmitter antenna vandalism (i.e. animal or human) protection and/or environmental stability (i.e. high wind, blizzard conditions, animals perching, etc.).
6. The **DA-ROCK1** is a popular accessory with all of our wireless systems, and is used to hide the DA-610 Sensor.
7. The **DA-058 Chime** is the chime used with the model DA-503 and DA-504 Drive-Alert.
8. The **DA-059 Wall-Switch and the DA-060 Lamp Module** are used with the model DA-504 Drive-Alert.
9. The **DA-066 Chime Transmitter, DA-068 Plug-in Chime, and DA-070 Battery-Powered Portable Chime** are the chime systems used for the *NEW* DA-605 Drive-Alert.
10. The **DA-660 Long Range Antenna** is an option that can be used with all of Mier's Wireless Drive-Alert Systems to boost the range from the sensor to the control panel to over a half-mile.
11. The **DA-611 Sensor/Transmitter** is an optional sensor that can be used in place of, or in conjunction with, the DA-610 Sensor with any of Mier's Wireless Drive-Alert Systems. The DA-611 is used in applications where it is impossible to place a DA-610 close to the driveway or area needing monitoring.



DA-660



DA-611TO

WIRELESS DRIVE-ALERT SENSOR INSTALLATION FOR ALL MODELS



DA-610
Sensor/Transmitter



DA-611 (*Option)
Sensor/Transmitter

DA-610 SENSOR/TRANSMITTER INSTALLATION (page 1 of 2):

The Model **DA-610 (or optional DA-611) Sensor/Transmitter** contains the sensing and transmitting electronics and is to be placed in the area of detectable moving vehicles. The detection threshold is set by a sensitivity control (See FIGURE 1-lower Right Hand quadrant) on the transmitter circuit board. Maximum sensitivity adjustment is Clockwise and minimum is Counter-Clockwise. In most cases the factory sensitivity and address code setting will function for the installation. If a unique address code is needed (e.g. interference from a neighboring Mier wireless system) open the top cover revealing the transmitter circuit board. Look for the blue and white rocker switches labeled ADDRESS in the lower middle of the circuit board near the Power Switch (see FIGURE 1).

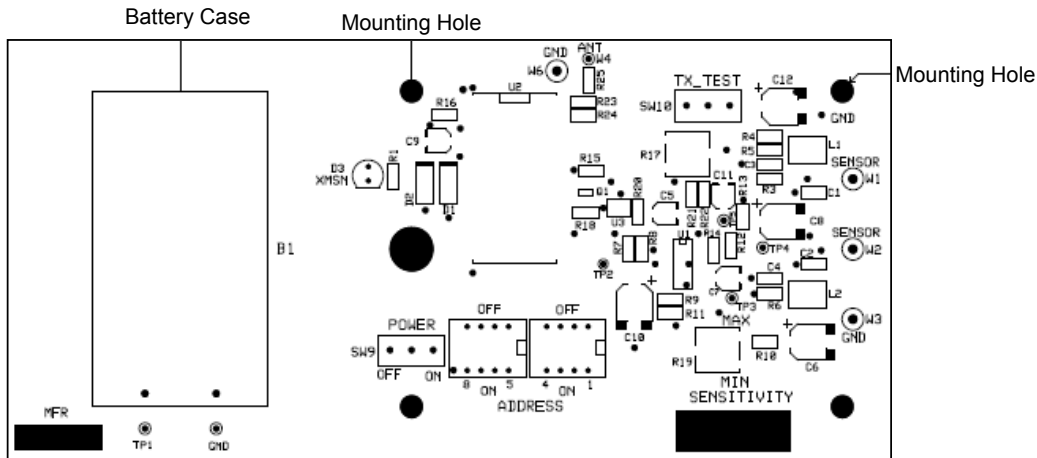

FIGURE 1

The address code switches are factory preset to OFF, in other words all 0's (e.g. 0 = OFF then 1 = ON). To set 1001, switch 1= ON, switch 2 = OFF, switch 3 = OFF, switch 4 = ON, and etc. The corresponding Receiver address MUST match this Sensor/Transmitter address for reception from this Sensor/Transmitter.

The Sensor/Transmitter operates on 2 - AA batteries providing 3.0 volts DC to the electronics. When battery voltage reaches 2.7 volts a signal is transmitted and the LO BATT LED is lit in the Receiver. The transmitter continues to operate for a time but new batteries will be needed for uninterrupted operation. Typical battery life is 1 year in a residential installation with Alkaline batteries. To install batteries, unlock and open the cabinet door, turn off the Power switch (see FIGURE 1), remove and install batteries, observing the correct polarity. Turn on the Power switch (see FIGURE 1), close and lock the cabinet door. When working on the transmitter, it is advised to unplug the Receiver to prevent false alarms. An LED marked XMSN near the center of indicates "valid sensor detection and that it is being transmitted". A switch marked as TX_TEST near the top puts the Sensor/Transmitter into a "continuous transmit" mode when the lever is set toward the SW10 side. Both of these are meant to be used during setup and troubleshooting.

[*NOTE: The optional DA-611 (Addendum C) is used in cases where it is impossible to securely place the DA-610 near the drive or area that needs monitoring, but it still provides the same sensing & wireless performance.]

The factory SENSITIVITY (see FIGURE 1 lower right) set is adequate detecting and sending an alert for a sedan at 5 mph and 10 feet from the sensor and larger vehicles moving in excess of 50 mph at 50 feet. But at maximum a sedan at 5 mph sedan detected at 12 feet and large high speed vehicles will be detected at 70 - 80 feet and at minimum a sedan at 5 mph sedan at 6 feet and large high speed vehicles at 40 feet.

WIRELESS DRIVE-ALERT SENSOR INSTALLATION FOR ALL MODELS

DA-610 SENSOR/TRANSMITTER INSTALLATION (page 2 of 2):

With factory settings, install the Sensor/Transmitter at least 60 feet from streets or roads (see FIGURE 2). FIGURE 2 illustrates a typical installation for all receivers and transmitters.

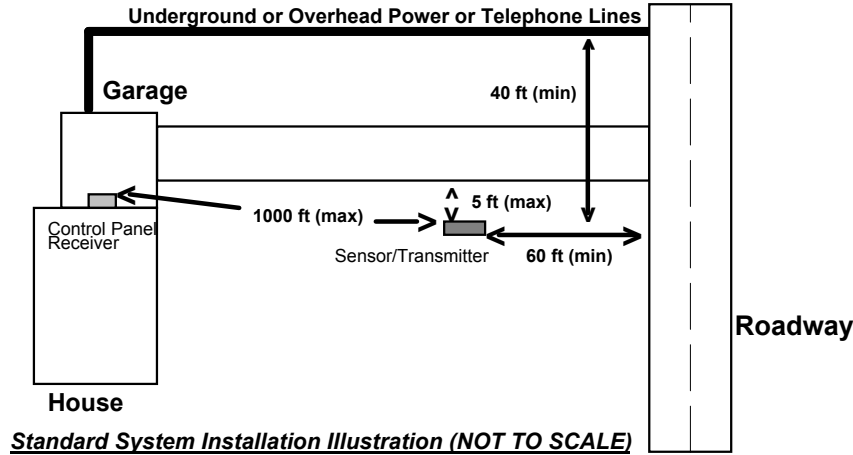

FIGURE 2

To aid in reliable transmitter installation, please follow these **DO's** and **DON'Ts**:

TRANSMITTER INSTALLATION DO's and DON'Ts

1. **DO** mount DA-610 cabinet or sensor of the optional DA-611 parallel to the driveway
2. **DON'T** point the antenna at the passing vehicle
3. **DO** mount the DA-610 securely. **IT MUST BE STABLE AND MOTIONLESS!!!!**
4. **DON'T** mount the DA-610 on a tree. If a tree mount is needed use the optional DA-611.
5. **DO** avoid power surges (any lightning, movement, or power surges in the sensor area will cause false alarms)

For a simple driveway installation, the unit can be turned on, locked, and placed on the ground near the drive and the signal will still be received by the Control Panel up to 500 feet away (line of sight).

Some mounting options are to cover it with a fake rock (see DA-ROCK1 on accessories page) or other non-metallic cover, place the box in a nearby bush, or firmly bolt the case to a **STABLE** wood, plastic, or metal post. A 4 X 4 mail box or fence post may be used. The unit can be bolted to an inside or outside a building wall.



NOTE: Any moving metal objects such as a gate, metal fence or metal garage door that may move with wind should be considered and located outside the detection range to minimize false alarms that could occur.

MODEL DA-600 WIRELESS DRIVE-ALERT

MODEL DA-600 CONTROL PANEL/RECEIVER GENERAL INFORMATION:

The Model **DA-600 Drive-Alert** is a direct wireless replacement for the original hard-cabled DA-500 model. As in the DA-500 the relay contacts may be supplied with 24 volts DC or used as Form C dry contacts. An internal piezoelectric whistle for alarm sounding is inside the control panel. The whistle may be switched off if desired, and when switched off the relay contacts are converted to Form C dry contacts. The DA-600 will operate the **DA-655 Chime with Volume Control**, the **DA-505 Timer Control** for extended light control, the **DA-052 Remote Whistle**, the **DA-057 X-10 PowerFlash** which interfaces with the **DA-058 Remote Chime**, and the **DA-066 Remote Chime Transmitter** which interfaces line of sight with the **DA-068** and **DA-070 Chimes**. It can also be used to control other external bells and relays. An adjustable time control provides 2 to 12 seconds of alarm time for each vehicle detected.

DA-600 COMPLETE INCLUDES: ONE DA-600 CONTROL PANEL AND ONE DA-610 SENSOR - (DA-611 OPTIONAL)



DA-600
Control Panel/Receiver



DA-610
Sensor/Transmitter

MODEL DA-600 WIRELESS DRIVE-ALERT

DA-600 CONTROL PANEL/RECEIVER INSTALLATION:

The DA-600 receiver is to be mounted inside where 110 volts AC power is available 4-6 feet above ground level. To maximize transmitter reception the flexible antenna is to be at least 12 inches from any metal pipes, power conduits, breaker boxes, etc. For extended ½ mile range reception, or for mounting below ground, use the DA-600 Long Range Complete system (i.e. DA-600LR) which includes a factory installed accessory and a DA-660 Long Range Booster Antenna.

A Red power lamp (see FIGURE 3 labeled LED 1) indicates that the power is on and that the internal 1 Amp Fuse is okay. An Amber lamp (see FIGURE 3 labeled LED 2) indicates a low battery condition at the Sensor/Transmitter. This lamp will stay on until the battery voltage in the transmitter is above 2.7 volts DC. **NOTE:** Before changing batteries, unplug the receiver and wait at least one minute after replacing batteries before applying power. This prevents unwanted alarms and resets the low battery detector.

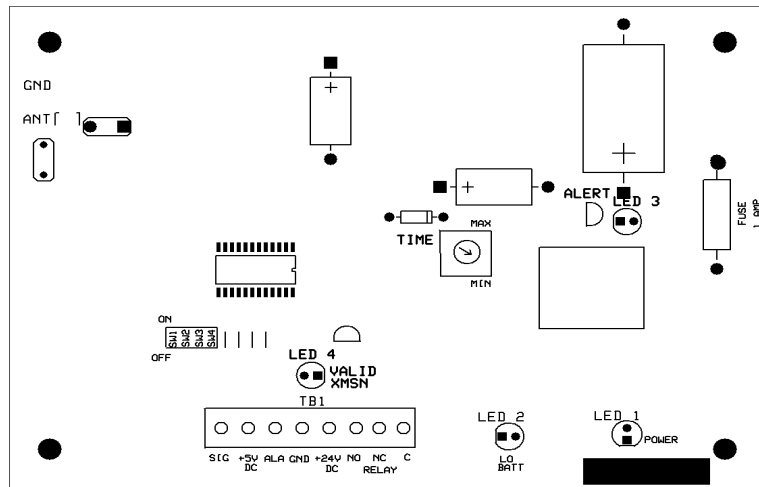
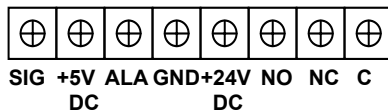

FIGURE 3

Under the unit cover are the address code switches (see FIGURE 3 SW1, SW2, SW3, SW4 in left lower quadrant) that must be set to match those in the transmitter. These switches are preset at the factory for code 0000. They should only be changed if the transmitter code is also changed. Also there is an alarm time control (see FIGURE 3 TIME near middle) which is preset at minimum of 4 seconds of alarm time. The maximum alarm time is 12 seconds. LED 4 (VALID XMSN) is on when the Receiver detects a valid transmission of its address and LED 3 (ALERT) is on when the relay is closed. On the outside of the Receiver is a WHISTLE ON-OFF switch. This switch basically provides or removes the 24 volt DC available at the relay output. The common contact of the relay receives 24 volts DC from this switch. In the “whistle off” position, the relay provides Form C dry contacts for external device control. The terminal block, TB1, provides a convenient wire connection point for external device control and test points (See FIGURE 4 for a detailed description of the contacts available).

DA-600 RECEIVER TERMINALS:



- SIG = Received Signal Strength (e.g. 1-1.5VDC = No Signal; 1.6-2.5VDC = Signal)
- +5VDC = 5 Volt DC Logic Power @ 25mA (max)
- ALA = Alarm Signal (0 - 1vdc = No Alarm; 4 - 5 VDC = Alarm)
- GND = Unit Ground, Earth Ground
- +24VDC = Power Supply for 24 VDC @ 100mA (max) accessories
- NO = Normally Open Relay Contact
- NC = Normally Closed Relay Contact
- C = Common Relay Contact

FIGURE 4

NOTE: The DA-600 receiver will operate on 12 VDC. An auto battery with the positive (+) connected to the +24 VDC terminal and negative (-) connected to the GND terminal will operate the DA-600. Therefore, the control panel can become portable (the sensor is always portable) so the unit can be used in a vehicle or at a remote site.

NOTE: DO NOT PLUG THE UNIT INTO 110 VAC IF OPERATED ON BATTERY AS IT CAUSES FAILURE

MODEL DA-600 WIRELESS DRIVE-ALERT

DA-600 APPLICATION DRAWINGS:

Following are sample connections using various accessories which may be similar or exactly what is needed:

WHISTLE ON
Connection using relay contacts switching internal power

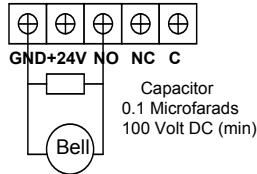

+24VDC Bell (e.g. DA-063)
NOTE: Limit of 2 external bells

WHISTLE ON
Connection using relay contacts switching internal power

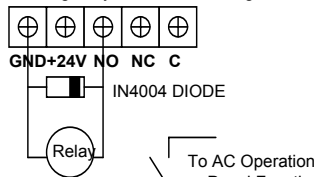

+24VDC External Relay
Limited to 100 milliamperes

FIGURE 5A

WHISTLE OFF
Connection using dry contacts and external power

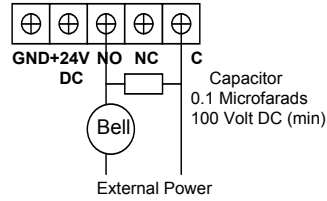

Maximum Current
Limited to 1 Ampere
Maximum Voltage is 24 Volts (DO NOT apply 120VAC to te

WHISTLE OFF
Connection using relay contacts switching internal power

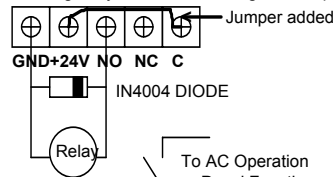

+24VDC External Relay
Limited to 100 milliamperes

FIGURE 5B

Using AC House wiring for Transmitting Alarm Signal

Method A (with internal Whistle ON)
Using the DA-057 to chime

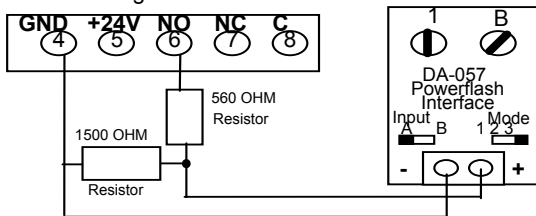

Input = A, Mode = 3 Unit = 1 House = B

FIGURE 6A

Method B (with internal Whistle OFF)
Using the DA-057 to chime

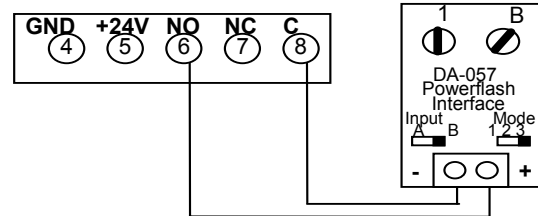

Input = B, Mode = 3 Unit = 1 House = B

FIGURE 6B

Using Line of Sight Wireless to Transmit Alarm Signal

Using the DA-066 to chime either/or DA-068/070

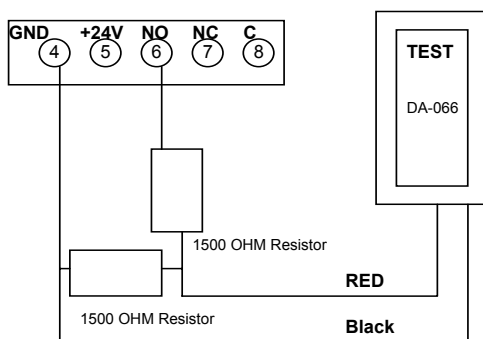

Method A (with internal Whistle ON)

FIGURE 7A

Using the DA-066 to chime either/or DA-068/070

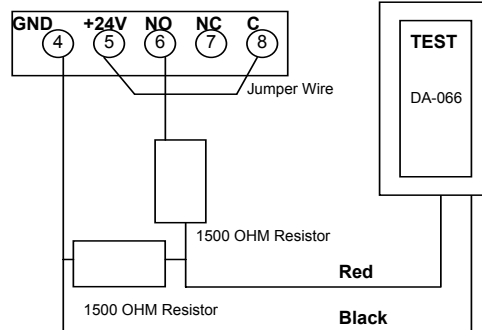

Method B (with internal Whistle OFF)

FIGURE 7B

MODEL DA-600 CONTROL PANEL/RECEIVER & DA-610 SENSOR/TRANSMITTER

SPECIFICATIONS:

DA-600 CONTROL PANEL/RECEIVER:

1. INPUT POWER: 120 VOLTS AC 50-60 HZ, 3 WATTS
2. OUTPUT POWER: 24 VOLTS DC AT 100 MILLIAMPERES
3. FREQUENCY: 433.92 MHZ FIXED SUPERHETRODYNE
4. ANTENNA: ¼ WAVE MONOPOLE FIXED BOLTED IN STEEL CASE 0 DBI GAIN
5. RECEIVER: LINX TECHNOLOGIES MODEL LR
6. DECODER: HOLTEK MODEL 658 IC TEN ADDRESS LINES 8 DIGITAL LINES.
7. LAMPS/LEDS: *POWER=RED, LO BATT=YELLOW, VALID XMSN=RED, ALARM=RED*
8. OUTPUT: PIEZO WHISTLE AND 24 VOLT RELAY
9. ALARM TIME: ADJUSTABLE 2 TO 12 SECONDS FOR EACH ALARM.
10. OPERATING TEMP: 0 DEGREE F. TO +105 DEGREE F.
11. WEIGHT: 2.5 POUNDS.

DA-610 SENSOR/TRANSMITTER:

1. POWER REQUIREMENTS: TWO (2) SIZE AA (LR-6) BATTERIES 3.0 VOLTS DC
2. OPERATING FREQUENCY: 433.92 MHZ FIXED
3. ANTENNA: 1/4 WAVE MONOPOLE BOLTED INTO THE STEEL CASE. 0 DBI GAIN
4. TRANSMITTER OUTPUT: 2 MILLIWATTS
5. TRANSMITTER: LINX TECHNOLOGIES MODEL KH ENCODER/TRANSMITTER
6. ENCODER MODULATION: AMPLITUDE ON-OFF KEYING (OOK) AT 1200 BPS.
7. ADDRESS CODES: FOUR POSITION DIP SWITCH SELECTED FOR THE ENCODER
8. DATA: ONE DATA BIT ENCODED WHEN BATTERY IS LOW.
9. TRANSMITTER ON TIME: LESS THAN 5 SECONDS FOR ANY SINGLE ALARM
10. ENCLOSURE: 18 GAUGE GALVANEAL PAINTED STEEL WITH WEATHER SEAL AND LOCKABLE LATCH CLOSURE.
11. QUIESCENT CURRENT : 60 MICROAMP
12. ACTIVE CURRENT: 3 MILLIAMP
13. BATTERY LIFE: ABOUT ONE YEAR IN RESIDENTIAL USE.
14. OPERATING TEMP: -40 DEGREES F TO + 125 DEGREES F
15. WEIGHT: FOUR POUNDS
16. DETECTION OF VEHICLES: DISTANCE FROM SENSOR/TRANSMITTER UNIT FOR STANDARD SEDAN MOVING AT 5 MPH= 14 FEET (MAX), 8 FEET (MID), 6 FEET (MIN)

MODEL DA-603 WIRELESS DRIVE-ALERT

GENERAL INFORMATION:

The **DA-603 Drive-Alert's** receiver board is the same as the one used in the DA-600 receiver (see FIGURES 3-4). The DA-603 does not have an internal whistle, whistle switch or Form C dry contacts available. There is however, relay switched +24 VDC when the alarm signal occurs (See FIGURES 5A, 6A & 7A for application information). This alarm signal is used to switch on an X-10 Powerflash Interface module (e.g. X-10 - PSC-01, Mier Part Number **DA-057**). This module sends a signal through the internal AC wiring in the house/building to trigger a remote chime: (e.g. X-10 PHH-02, Mier Part Number **DA-058**). The unit and house code of the **DA-057 Powerflash** Interface must match the unit and house code set on the **DA-058 Remote Chime**. The Powerflash Interface Input switch must be on "A" and the Mode switch must be set to "3." (See FIGURE 8).

INSTALLATION:

For Sensor/Transmitter installation details see FIGURES 1-2. The DA-058 chimes may be located in multiple rooms and the DA-603 can chime an unlimited number of DA-058 chimes within 300 feet of the DA-603. Simply plug the Control Panel in a standard wall outlet, in an out of site space where the signal from the DA-610 Sensor can reach it. Then, plug in the DA-058 Remote Chime(s) in an area(s) of the house where an alert is desired.



DA-603 complete pictured

(Includes: one Control Panel with internal DA-057 Powerflash, one DA-610 Sensor, and one DA-058 Remote Chime)

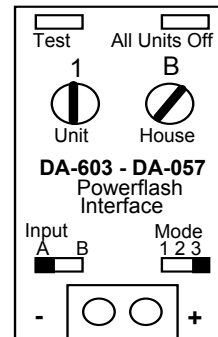

Unit in the "1" and House in the "B" positions
Input in the "A" and Mode in the "3" positions

FIGURE 8

TESTING FOR POWERFLASH COMMUNICATION:

To test the Powerflash Interface to chime signal path, push the TEST button and the chime will sound. The chime will also sound when first plugged into an AC power socket. If this test does not work, try the wall outlet the DA-603 is plugged into or another in the building. Some outlets may not work because they are on the opposite phase of the 220 VAC coming from the building transformer. In this case, an *X-10 Passive Coupler model XPCP* will need to be installed in the building breaker box by a licensed electrician all outlets are to work. See www.x10pro.com for details and local distributors of X-10 products.

NOTE: The DA-058 remote chime does not have any volume control nor tone selection controls. For those features, the DA-605 is the model to be used. Furthermore, in homes where there is a significant amount of fluorescent lighting, computers, wireless phones, and other electronic "noise" and DA-605 is preferable to the DA-603.

One DA-058 remote chime is included with each system, and extras may be ordered. A diagram of the circuit layout and function is located inside the cabinet door.

MODEL DA-604 WIRELESS DRIVE-ALERT

GENERAL INFORMATION:

The **DA-604 Drive-Alert** gives you the same features as the DA-603, plus the ability to easily activate lamps, overhead lights, and/or outside lights without hard wiring!



DA-604 Complete pictured

(pictured with optional second lighting source)

Includes one DA-604 control panel, two DA-057 Powerflashes, one DA-610 Sensor, one DA-058 Remote Chime and a *CHOICE* of one DA-059 Wall Switch **OR** one DA-060 Lamp Module for lights.

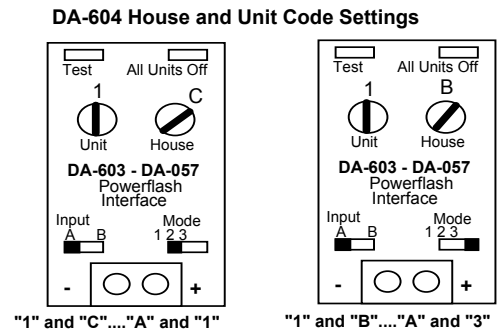

FIGURE 9

The DA-604 Drive-Alert's receiver board is the same as the one used in the DA-600 receiver (see FIGURES 3-4). The DA-604 does not have an internal whistle, whistle switch or Form C dry contacts available. There is however, relay switched +24 VDC when the alarm signal occurs (See FIGURES 5A, 6A & 7A for application information).

The DA-604 contains two X-10 Powerflashes. Just like the DA-603, the accessories must be on the same AC phase as the Receiver. The right hand Powerflash signals remote chimes alarmed. The X10 Powerflash module on the left side is used to signal wall switches (i.e. DA-059) and/or lamp modules (i.e. DA-060) to turn on lights. One DA-058 Chime, and your choice of a DA-059 Wall Switch or a DA-060 Lamp Module, are included with each system. The Powerflash Interface settings are shown in FIGURE 9 (above). The Timer Board is depicted in FIGURE 10 (below).

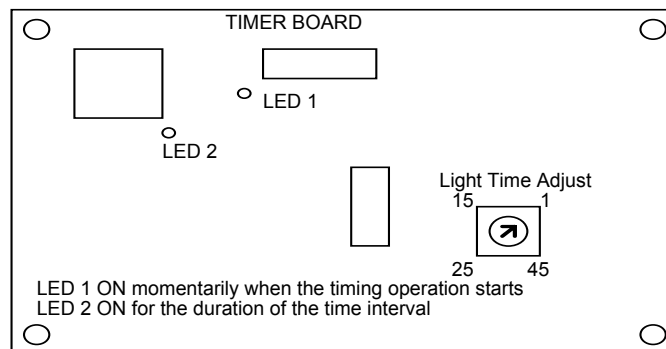

FIGURE 10

A circuit layout diagram, setting details and a functional description is located inside the cabinet door and covers the main circuit board, the Powerflashes and the Light Timer Control Board. **The DA-059 Wall Switch** handles up to 300 watt loads and can manually be used to turn on lights. **The DA-060 Lamp Module** plugs into any standard wall outlet and every time the DA-604 receives a signal from the DA-610 Sensor the lamp will be activated. The lamp functions normally as well. **The Timer Board** located above the main control board has LED lights to indicate when the timer circuit is active. LED 1 indicates an alarm condition has been initiated and will remain on for a few seconds. LED 2 will remain on for the duration of the timed cycle set with the time-adjust control. The timer board control can adjust the "lights on" time for 45 seconds at minimum to 45 minutes at maximum (see FIGURE 10). **The DA-058 Remote Chime** is the same as described under the DA-603 model instructions. The X-10 Powerflash Interface test buttons can be used to verify that the chime and/or light switch are receiving a control signal. The DA-058 chime should sound when the right module test button is pushed. The lamps connected to the DA-059 switch should come on briefly when the left module test button is pressed. If the units do not operate properly, see the DA-603 TESTING FOR POWERFLASH COMMUNICATION in the DA-603 section of this manual.

MODEL DA-605 WIRELESS DRIVE-ALERT

GENERAL INFORMATION:

The **NEW DA-605 Drive-Alert's** receiver board is the same as the one used in the DA-600 receiver (see FIGURES 3-4). The DA-605 does not have an internal whistle, whistle switch or Form C dry contacts available. There is however, relay switched +24 VDC when the alarm signal occurs (See FIGURES 5A, 6A & 7A for application information). This model serves as an alternative to the DA-603 described on page 10. The advantages are with the remote chimes giving choice of either a **DA-068 Plug-in Chime** and/or the **DA-070 Battery-Operated Portable Chime**, each activated by a radio signal AND having tone and volume control while the DA-070 can be taken into the backyard, out to the pool & etc. Furthermore, homes with significant electronic "noise" from fluorescent lights and electronics might hamper a DA-603's performance, but will not interfere with the DA-605.



DA-605P Complete

Includes: DA-605 control panel
with one DA-610 Sensor, and one DA-068 Plug-in Remote Chime
(Optional DA-070 Battery Operated Portable Chime pictured on Accessories Page)

TESTING FOR RADIO TRANSMITTER COMMUNICATION:

The alarm signal is used to turn on the 315 MHz radio signal in the push button located on the side of the DA-605, which will sound the remote chime. This signal will reach at least 100 feet to the chime. The radio module located on the side of the housing contains a user accessible push button for test or "call" purposes. Internal to the module a 12 volt battery type A23 is contained and should last about 3 years. This battery is activated only when testing the radio module to chime signal path and does not have an effect on Drive-Alert operation. The chime can be tested independent of the Drive-Alert by pushing the button causing the chime to sound. The enclosure of the radio module can be opened by pushing in on the bottom latch carefully with a screwdriver and lifting up. Both the jumpers as well as the battery are now accessible. To re-seat the radio module enclosure carefully align and place the enclosure top locking tabs and carefully push in the bottom latch until it snaps closed. The DA-068 Plug-in Chimes and DA-070 Battery Operated Portable Chimes are factory preset for a one note chime sound. To change the sound to a two note chime, remove jumper #8 under the small cover on the back of the chime, and remove jumper #8 from the radio module located on the side of the housing. To obtain an 8 note Westminster sound, remove only the jumper from the radio module while leaving the jumper in the chime.

INSTALLATION:

For Sensor/Transmitter installation details see FIGURES 1-2. The DA-068 & DA-070 chimes may be located in multiple rooms/locations and the DA-605 can chime an unlimited number of chimes within 100+ feet of the Control Panel. Simply plug the Control Panel in a standard wall outlet, in an out of site space where the signal from the DA-610 Sensor can reach it.

Plug in the DA-068 Remote Chime(s) and place the DA-070 Portable Chimes in an area(s) of the house where an alert is desired. The DA-068 volume control is accessible on the back panel of the chime. However, the DA-070 must have its back removed to gain access to the volume control. The DA-070 Battery Operated Portable Chime needs three D size batteries which will last about 3 years.

For all options and operation instructions of the chimes, see the instructions enclosed with the chimes.

WIRELESS DRIVE-ALERT WARRANTY AND FCC/RADIO FREQUENCY INFORMATION

WARRANTY INFORMATION:

The Mier Products' Limited Warranty program covers only the Drive-Alert, for the original owner only, for one year from the date of purchase, against defects in original parts and/or original workmanship. It agrees to repair or replace such defects, Mier Products' option, without charge for parts or labor – if the defective unit is returned, within the one-year warranty period, prepaid to Mier Products, Inc., at 1500 North Ann Street, Kokomo, IN, 46901. Responsibility is not assumed for damage due to accident, faulty wiring, overload of Drive-Alert output, or installation other than that recommend by Mier Products, Inc. Repair work not covered by the Warranty will be made at a nominal charge. When returning a unit for any reason, call the 800 number in advance to schedule inspection/repair and please include a note with the unit describing the problem. Also include you name, address, and telephone number.

Additional information can be found on our website at www.mierproducts.com

**Free technical support is available by calling our hotline
between 8:00am and 5:00pm EST:
1-800-473-0213**

ATTENTION:

Any changes to equipment not authorized by Mier Products, Inc. could void the user's authority to operate these units and void the warranty.

This equipment has been tested and found to comply with the limits for a class B digital device pursuant to Part 15 of the FCC Rules. These limits are designed to provide reasonable protection against harmful interference in a residential installation. This equipment generates, uses, and can radiate radio frequency energy: if not installed and used in accordance with the instructions, this equipment may cause harmful interference to radio communications.

However, there is no guarantee that interference will not occur in a particular installation. If this equipment does cause harmful interference to radio or television reception, which can be determined by turning the equipment off and on, the user is encouraged to try to correct the interference by one or more of the following measures.

- Reorient or relocate the receiving antenna.
- Increase the separation between the equipment and receiver.
- Connect the equipment into a different outlet than the receiver.
- Consult the dealer or an experienced radio/TV technician for help.

**ADDENDUM: THE FOLLOWING PAGES ARE ADDITIONS TO THE ORIGINAL
INSTALLATION BOOKLET:**

Appendix A1

MIER PRODUCTS' Wireless *QUICK-START* Installation

Appendix A2-A4

(FAQs) - Frequently asked questions and troubleshooting tips

Appendix B

DA-655 Chime

Appendix C

DA-611 Remote Sensor/Transmitter with 50' of direct burial cable

Appendix D

DA-660 Long Range Antenna (factory installed accessory)

Appendix E

DA-066 Remote Chime Transmitter

Appendix F

DA-067 Antenna Stabilizer

Appendix G

DA-ROCK1 Discreet Sensor Cover

MIER PRODUCTS' WIRELESS DRIVE-ALERT *QUICK START GUIDE*

STEP BY STEP AT IT'S BEST

1. **Unpack** the Transmitter (Gray in color), Receiver (Bone in color), Power Cord, Sounders and/or Controls
2. Test the system before installation by
 - Plugging in the Receiver. If it has a Whistle Switch (e.g. DA-600) turn it on.
 - If the system is equipped with wireless chimes, plug one in nearby the Receiver.
 - Opening the lid of the Transmitter, **installing 2-AA Batteries** and **turning on** the power switch and observing the XMSN LED being lit.
 - Confirm that the Whistle, Chimes, Light Controls or other accessories have activated.
 - Turn OFF the Sensor/Transmitter and repeat the alarm sequence by turning the power of the unit on again.
 - Close the Sensor/Transmitter Lid, Turn ON power one final time and wait for about 1 minute and then move the Sensor/Transmitter or wave a steel screwdriver or pliers along the latch side of the unit and observe the sounder and/or accessories activating.
3. Take the Sensor/Transmitter and place it long ways **within 5 feet** of the **edge of the driveway** to be detected at about the location where you propose to install it.
4. Place the Receiver **at least 4 feet** above ground in the proposed installation location and plug the power cord into an AC receptacle. The power light in the lower right hand corner of the Receiver will now be ON.
5. Make certain the sounders are on:
 - On models containing a piezo whistle, **slide Whistle Switch to ON** or
 - On models using wireless chimes and/or controls **plug-in or install batteries in remote wireless sounders**
6. Test the system using a vehicle to pass by the Transmitter @ 5MPH or by swinging a steel shovel along the long side of the Transmitter setting off the sounder signal.
7. Once testing is successful, choose the final mounting locations and perform Step 6 repetitively for consistent detection and finalize installation.

NOTE: AVOID THESE !!!

- Putting the Receiver in a basement without the use of a Long Range Antenna & Long Range Receiver
- Hills in the terrain existing between the Transmitter and Receiver of greater than 4 Feet without the use of the Long Range Antenna & Long Range Receiver
- Burying the Transmitter in the ground.
- Shielding the Transmitter in an Aluminum, Copper or Steel enclosure
- Heavy gauge Aluminum or Steel obstructions in direct path of the line-of-sight from the Transmitter to the Receiver
- Aluminum or Steel electrical enclosures or conduit within 12 inches of Receiver installation
- E-Glass window in the direct path of the line-of-sight between the Transmitter and Receiver
- Receiver mounted behind a Stucco wall without the use of a Long Range Antenna/Receiver mounted so that the Stucco wall does not interfere between the Transmitter & Receiver
- Mounting Transmitter more than 5 feet from the edge of the driveway to be detected
- Mounting the Transmitter on a tree as they twist in the wind causing false alarms to occur.
- Mounting the Transmitter greater than 4 feet above the ground creating detection misses as most vehicles are non-ferrous above the belt line.

FAQs (FREQUENTLY ASKED QUESTIONS) AND TROUBLESHOOTING GUIDE

Q: How many Sensor/Transmitters can be used?

A: Unlimited, however there is no way to discriminate which Sensor/Transmitter is causing the alert to sound.

Q: How many sound devices can be used?

A: See the following list and quantities supported:

•DA-063 8" Bell	QTY 2
•DA-052 Remote Whistle	QTY 10
•DA-058 X10 Chime (w DA-603/604 or added DA-057)	QTY Unlimited
•DA-068 Wireless AC Chime	QTY Unlimited
•DA-070 Wireless Battery Chime	QTY Unlimited
•Miscellaneous Sounder	QTY # That adds to 100mA(max) load

Q: Does the unit have the capability when it determines an alarm is to be sounded, to trigger another device.

A: Each unit DOES have this capability as the 3 contacts from the alarm relay are available for use at the Terminal Block (Terminals 6-8). In models that DO have an internal Whistle and corresponding switch these contacts normally switch +24 Volts but can become Form C dry contacts when the Whistle Switch is in the OFF position. In those models that DO NOT have an internal Whistle, and corresponding switch, these contacts will always be switching +24 Volts.

Q: Can a camera be activated by the Drive Alert.

A: Yes, by using the Form C dry contact mode or by buffering with an external relay in the non-dry contact mode.

Q: Can a gate be activated by the Drive Alert.

A: Yes, by using the Form C dry contact mode or by buffering with an external relay in the non-dry contact mode but safety care should be taken for the event a person or vehicle in the gate's path.

Q: Can vehicles be counted using the Drive Alert.

A: Yes, by using the Form C dry contact mode or by buffering with an external relay in the non-dry contact mode.

Q: Can the Drive Alert provide a contact closure for detection to open or lift an arm and then close it when the vehicle has cleared the area.

A: No, it does not provide intelligence beyond the simple sensing that the magnetic field has been disturbed. Once disturbed a closure occurs for a user defined time up to 12 seconds at which time the gate or arm will then return to its home position. For these types of functions external logic and timing is required.

Q: Can the Drive Alert sense which way the vehicle is traveling?

A: No, it does not include this capability and would require either external methods or the use of two systems and most likely external logic to sequence the two systems for this determination.

Q: How can I determine if something NOT a magnetic metal is moving?

A: Within the range of the sensor, attach a magnet or a metal that has magnetic characteristics such as steel. Now whenever it moves the sensor senses it, transmits to the Receiver/Control Panel and the alarm is set off.

Q: Does the Drive Alert sense people?

A: No, it does not sense people or animals, only changes that result in a magnetic field disturbance. So, if sensing of people or animals is needed to use the Drive Alert, then a magnet or significant magnetic metal must be in existence with that which is trying to be sensed.

Q: My unit sounds an alert immediately when plugging in then stops after about a couple minutes or so. Why?

A: During the initialization of both the Sensor/Transmitter and the Receiver/Control Panel, a test tone is provided to allow recognition by the user that power has been received. In the case of the Sensor/Transmitter it is transmitting and in the case of the Receiver/Control Panel it is recognizing test alarm conditions and can sound the alarm.

FAQs (FREQUENTLY ASKED QUESTIONS) AND TROUBLESHOOTING GUIDE

CONTINUED

Q: Both the Sensor/Transmitter and Receiver/Control Panel are installed but no function is occurring.

A: Check the following

- Receiver/Control Panel Power Lamp is ON.
- Sensor/Transmitter batteries are installed.
- Sensor/Transmitter Power switch is switched to ON. XMSN LED is On when Power Switch is first turned ON.
- Low Battery Lamp in the Receiver/Control Panel is OFF. If ON then install fresh AA Alkaline batteries.
- Receiver/Control Panel is 12 inches or more away from conduits, breaker boxes and etc.
- Sensor/Transmitter code switches match the Receiver/Control Panel code switches.
- Sensor/Transmitter DOES cause an alarm when positioned within 36 inches of the Receiver/Control Panel.
- Sensor/Transmitter Does cause an alarm when ~ 100 feet away from the Receiver/Control Panel.
- Sensor/Transmitter antenna is oriented in the same direction as the Receiver/Control Panel antenna.
- Sensor/Transmitter antenna IS NOT surrounded by Aluminum, Copper, Lead or other metals which absorb and attenuate signals
- Receiver/Control Panel LED 4 is ON indicating a VALID XMSN is received and LED 3 ALERT is ON.
- Receiver/Control Panel is 4-6 feet above ground, unless using an external antenna 10 feet above the ground connected to a Receiver/Control Panel mounted below ground.
- Sensor/Transmitter and Receiver/Control Panel are no more than 500 feet apart if Sensor/Transmitter is on the ground, 1000 feet if the Sensor/Transmitter is located 4-6 feet above ground level or no more than 2500 feet if using the Long Range Antenna (i.e. DA-660) option.
- If using the DA-660 antenna it MUST be mounted horizontally 10 feet or more above ground and pointed (short elements closest to Sensor/Transmitter and longest elements furthest away from Sensor/Transmitter) at the Sensor/Transmitter from which to receive signal.
- Sensor/Transmitter antenna IS NOT trying to transmit through a hill to the Receiver/Control Panel. It IS either transmitting on the same level or up a hill to the Receiver/Control Panel or down a hill to a Receiver/Control Panel that IS mounted above ground at its location yet physically lower than the Sensor/Transmitter unit.
- Sensor/Transmitter signal to the Receiver/Control Panel is clear line of sight.
- Foliage IS NOT causing signal interruption due to loss of line of sight.
- If dense foliage MUST be penetrated, recommend Long Range system which includes the DA-660 antenna to improve reception at the Receiver/Control Panel.
- Sensor/Transmitter DOES cause alarm when first powered on after Receiver/Control Panel has had power applied for over 1 minute. Evaluate installation locations again and move if necessary.

Q: Sensor/Transmitter and Receiver/Control Panel communication is verified but NO alarm (sounder or lights) occurs for magnetic field disturbances. Why?

A: Check the following:

- The Sensor/Transmitter batteries are installed and the power switched on.
 - The Sensor/Transmitter code switches match those of the Receiver/Control Panel.
 - Check to make sure the Sensor/Transmitter is mounted in a position 4 foot or less in elevation.
 - Check to make sure the Sensor/Transmitter is mounted in a position no further than 5 feet away from traffic flow.
 - Sensor/Transmitter sensitivity may be set too low. Open the cover and using a small screwdriver carefully turn the sensitivity control clockwise to increase the sensitivity toward maximum.
 - Check that the Sensor/Transmitter responds to a good tool steel shovel, pliers by waving them quickly past the latch side of the DA-610 Sensor/Transmitter unit or across the buried Remote Sensor of the DA-611
- Check that the vehicle to be detected contains magnetic type materials (e.g. actual magnets) or materials that can be magnetized (i.e. Steel, Iron, Cobalt, certain Nickel Alloys and etc.).
- If using X10 implementations (e.g. DA-600 with added DA-057 and DA-058 or a DA-603 or DA-604) check that the wiring of the DA-057 is correct and that the Input and Mode switches are set right then use the Test Button on the DA-057 Powerflash to verify the signal path to the sounder or light control being used.
 - If X10 devices are not functioning, move them to the same receptacle as the Receiver/Control Panel and retry.
 - If X10 devices are functioning in only some places, and the devices have been verified as good a phase coupler OR noise suppressor (both available from <http://www.x10pro.com>) may be required to get all functioning correctly.

FAQs (FREQUENTLY ASKED QUESTIONS) AND TROUBLESHOOTING GUIDE CONTINUED

Q: Sensor Transmitter and Receiver/Control Panel are accurately alarming BUT false alerts are also occurring. Why?

A: Check the following:

- The code that was chosen is not being used by a neighbor within a 2000 foot radius using a standard installation (e.g. non-Long Range) and one mile radius if using a Long Range installation.
- The Sensor/Transmitter IS located 40 feet away from power lines.
- The Sensor/Transmitter is **SECURELY MOUNTED** and **NO MOVEMENT IS OCCURRING**.
- Check to ensure that the sensor located in the Sensor/Transmitter enclosure can not slide back and forth.
- Notice if there is vibration sources in the area that the false alerts may be coincident with.
- Slow moving low density magnetic field disturbing items are greater than 15 feet away (e.g. metal gates, fences, motors or motor controls, magnetic security devices, low or high voltage landscape lighting, telephone communication wiring or etc.).
- The Sensor/Transmitter IS located at least 50 feet off any roadway that carries light slow to medium traffic speed and 75 feet minimum off any roadway that carries medium to heavy traffic speed. Should the Sensor/Transmitter be picking up large vehicles such as Trains, Logging Trucks, Agricultural, Semi-Tractor Trailers, School Buses and the like some work may be needed to identify the best location and sensitivity setting to satisfy the needs of the specific application.
- Check that environmental effects **ARE NOT** occurring with the Sensor/Transmitter and its antenna (e.g. animals or humans disturbing it, strong high winds causing the unit to rock or the antenna to "wave" with the wind, blowing snow, sticks or clumps of leaves hitting the unit or antenna). If this is suspected, a DA-067 Antenna Stabilizer is recommended as part of the solution.
- If using an X10 implementation (e.g. DA-600 with added DA-057 and DA-058 or a DA-603 or DA-604) change Unit and House code dials.
- If using a DA-605 implementation change the code of the Radio Module and the Chime per included instructions.
- If using a DA-605 implementation check that automotive remote security door locking devices (e.g. also known as key fobs) **ARE NOT** causing false alarms to occur and change the Radio Module and Chime codes per included instructions is appropriate.



www.mierproducts.com

Wireless Vehicle Detection * Driveway Alarms * Drive-Up Window Detection * Buried Sensor Systems * Instrument Boxes * DVR Lockboxes Rack-Mount Lockboxes * CPU/DVR Tower Lockboxes * Flush-Mount Cabinets * Outdoor Enclosures * Temperature Controlled Enclosures Power Supply Boxes Siren/Speaker Cabinets * Bell Boxes * Battery Cabinets * Transformer Enclosures * Custom Enclosures & Fabrication

DA-655

Drive-Alert Chime with volume control

DA-655



- The DA-655 is the perfect accessory for the original DA-500 and the new DA-600 wireless Drive-Alerts when a more pleasant tone and/or volume control is desired.
- **Perfect for drive-up windows and high traffic areas**
- The DA-655 Chime replaces the whistle within the Drive-Alert, and emits a pleasant chime whenever a vehicle is detected.
- Volume can be adjusted from silent to a very loud setting
- Easy to install
- Connecting cables included

Call us! We'll be happy to help with any technical or installation questions...and don't forget to check out our website for more products!

Residential Driveway Application



Drive-Up Window Application



DA-600



Wireless DA-600 Complete Drive-Alert Driveway Alarm System is pictured above for reference.

DA-500



Original DA-500 Complete Drive-Alert Driveway Alarm System is pictured above for reference.



www.mierproducts.com

DA-611

Drive-Alert Transmitter with External Sensor

DA-611



DA-611 installation illustration of the sensor buried under the drive and the receiver hidden in a nearby tree.

The **DA-611 Remote-Sensor/Transmitter** is designed to work with any of the Wireless Drive-Alert Control Panel/Receivers:

Models: DA-600, DA-603, DA-604, DA-605

The DA-611 Transmitter/Sensor is identical to the DA-610 typically used with the Wireless Drive-Alerts with one exception: in the DA-610 the sensor is within the transmitter box, in the DA-611 the sensor is attached by a fifty foot cable to the transmitter box. This allows the sensor probe to be buried under or next to the driveway or area to be monitored, and the transmitter box to be hidden at a remote location. By stabilizing the sensor mounting, the system sensitivity is enhanced. Best transmitting range is still achieved by mounting the transmitter in an elevated position; a post (metal, wood or concrete), tree, or a convenient building can be used. However a 500 foot range, transmitter to receiver, can be obtained with the transmitter box on the ground, if no hills or dirt mounds are in the line of sight. Excess probe cable can be coiled.

The Sensor probe should be placed next to or under the driveway at least 75 feet from any street or road traffic to prevent false alarms. Reducing sensitivity by 50% would allow 60 foot distance from street or road traffic; however detection range for driveway vehicles is reduced to 12 feet, which should be adequate for most 20 foot wide driveways if the probe is placed right at the edge of the drive. The probe can be placed in any orientation, parallel or perpendicular to the drive.

DETECTION OF VEHICLES -

Distance from probe for a standard-size modern sedan moving 5MPH.

Maximum sensitivity	17 feet
Factory set sensitivity	16 feet
75% sensitivity	14 feet
50% sensitivity	12 feet
Minimum sensitivity	10 feet

For most homeowner installations, the probe should be buried 6 -12 inches below ground and the cable 3 - 6 inches. NOTE: Try the system above ground temporarily before burying. The entire system, probe, cable and transmitter can be above ground if there is little risk of probe or cable damage and the probe cannot move. Any movement of the probe will trigger an alarm. If occasional false alarms occur, reduce sensor sensitivity by turning the small brown sensitivity control slightly counterclockwise. Due to the large magnetic field disturbance, lightning strokes in the vicinity will cause an alarm. It is also possible for current variations in nearby power lines to cause an alarm.

Call us with any installation or technical questions: we'll be happy to help.

Don't forget to check out our website for more products!



www.mierproducts.com

DA-660

Long Range Antenna

DA-660

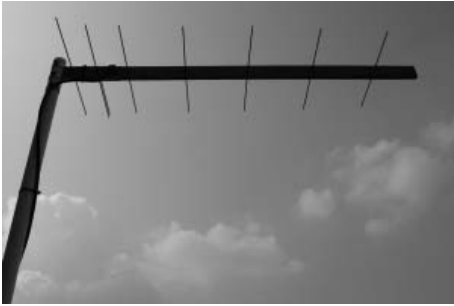

The DA-660 is pictured here mounted on a pole. The antenna may be mounted indoors or outdoors.



The DA-660 is the perfect accessory for monitoring remote buildings or locations up to 1/2 mile away.

- When a monitored location is more than 1000' away, the DA-660 is the perfect accessory for the wireless Drive-Alert Vehicle Detection Systems (models pictured below)
- This antenna boosts the normal Drive-Alert range up to 1/2 mile (2,500')
- The antenna measures 36" long, 13" wide, and 1.5" high. It weighs approximately 1 pound.
- This is a **FACTORY INSTALLED ACCESSORY** due to the fact that some components must be changed on the control panel for long range applications
- When ordering you must specify which Drive-Alert model you will be using (see four models below) AND state that a DA-660 Long Range Antenna is needed.
- Retro-fits must be shipped back to Mier Products for installation of the components needed for the long range antenna

**Please call us with any installation or technical questions, and we'll be happy to help.
Don't forget to check out our website!**

Mier Products' line of Wireless Drive-Alert Driveway Vehicle Detection Systems is pictured below for reference



www.mierproducts.com

Wireless Vehicle Detection * Driveway Alarms * Drive-Up Window Detection * Buried Sensor Systems * Instrument Boxes * DVR & CPU Lockboxes * Flush-Mount Cabinets * Outdoor Enclosures * Temperature Controlled Enclosures * Power Supply Boxes * Siren/Speaker Cabinets Bell Boxes * Battery Cabinets * Transformer Enclosures * Custom Enclosures and Fabrication

DA-066

Remote Chime Transmitter



**The DA-066
Remote Chime Transmitter**

The DA-066 Remote Chime Transmitter comes standard on the Model DA-605 Drive-Alert, and can be used to add the features of the DA-605 to existing Model DA-500s or Model DA-600s.

As standard equipment on the DA-605 Drive-Alert:

On the DA-605 Drive-Alert this DA-066 unit is part of the Control Panel. When a vehicle is detected, the DA-605/DA-066 sends a signal to activate DA-068 Plug-in Remote Chimes and/or DA-070 Battery-operated Portable Chimes.

The DA-066 can also be used as a “test” or “call” button to manually trigger the chimes.



**The DA-068
Plug-in Remote Chime**

As optional equipment on the DA-500 or DA-600 Drive-Alert models:

The DA-500 and DA-600 models come equipped with an electronic whistle in the control panel which serves as the alert when a vehicle is detected.

Often, customers later decide they would rather have a more pleasant sounding chime than the supplied whistle, volume control, would like to have alerts in multiple rooms or a portable alert, and/or would like to be able to manually trigger the chime as a “call button.” These can easily and quickly be accomplished by adding the DA-066 Remote Chime Transmitter to the dry contacts on these Drive-Alert models, to work in conjunction with DA-068 Plug-in Remote Chimes and/or DA-070 Battery-Operated Portable Chimes. These chimes provide a choice of a pleasant one-note tone, two-note chime, or westminster chime.



**The DA-070
Battery-Operated Portable
Chime**

NOTE: For industrial/business applications where a pleasant chime and volume control is needed (example: Drive-Up Window application) we suggest adding the DA-655 Chime With Volume to the DA-500 or DA-600 instead of the DA-066.

Call us with any installation or technical questions: we'll be happy to help.

Don't forget to check out our website for more products!



www.mierproducts.com

DA-067

Sensor Antenna Stabilizer



**The DA-067
Antenna Stabilizer**

The DA-067 Antenna Stabilizer slips over the top of the antennae on the DA-610 Drive-Alert Sensors to eliminate the problem of wind or animals moving the antenna and causing false alarms.

In rare cases, the standard antenna supplied with Mier's wireless Drive-Alert sensors become "perches" for birds, are moved by blowing branches in the wind, etc. If the antenna is moved enough, it will cause an alarm. The sensors are designed to be tamper-resistant and to sound an alert when tampered with. In these cases, the DA-067 Antenna Stabilizer should be added to eliminate these problems. The DA-067 simply slips down over the top of the standard antenna and secures to the lid of the sensor/transmitter.



**The DA-610
Sensor/Transmitter**



**The DA-611
Transmitter with External Sensor**

Mier Products' line of Wireless Drive-Alert Driveway Vehicle Detection Systems is pictured below for reference



www.mierproducts.com

Wireless Vehicle Detection * Driveway Alarms * Drive-Up Window Detection * Buried Sensor Systems * Instrument Boxes * DVR & CPU Lockboxes * Flush-Mount Cabinets * Outdoor Enclosures * Temperature Controlled Enclosures * Power Supply Boxes * Siren/Speaker Cabinets Bell Boxes * Battery Cabinets * Transformer Enclosures * Custom Enclosures and Fabrication

DA-ROCK1

Discreet Rock Cover for Drive-Alert Sensor

DA-ROCK1



The DA-610 Sensor which comes standard with all Wireless Drive-Alert Systems should be placed as close to the drive as possible. Many customers place the sensor under bushes, flowers, or other landscaping along the driveway. Others attach it to a post along the drive. However, many wish to keep the sensor out of site and do not have landscaping next to the drive in the area where they wish to place the sensor. For those applications we recommend placing the sensor under one of our discreet DA-ROCK1 faux-rocks. The sensor will be hidden from site, and will still detect vehicles and send the signal to the house without any impact on performance.

The dimensions of the hole within the hollow rock are:
14"W x 19"L x 12"H

The outside dimensions of the rock are only slightly larger.

**Please call us with any installation or technical questions,
and we'll be happy to help.
Don't forget to check out our website!**



Mier Products' line of Wireless Drive-Alert Driveway Vehicle Detection Systems is pictured below for reference



www.mierproducts.com

Wireless Vehicle Detection * Driveway Alarms * Drive-Up Window Detection * Buried Sensor Systems * Instrument Boxes * DVR & CPU Lockboxes * Flush-Mount Cabinets * Outdoor Enclosures * Temperature Controlled Enclosures * Power Supply Boxes * Siren/Speaker Cabinets * Bell Boxes * Battery Cabinets * Transformer Enclosures * Custom Enclosures and Fabrication