

**2014 – 2015**  
***9<sup>th</sup> Grade Curriculum Guide***

# District Personnel and CHS Administration

## Okaloosa County School District

Mary Beth Jackson .....Superintendent of Schools  
Kaye McKinley..... Deputy Superintendent  
Marcus Chambers.....Assistant Superintendent Curriculum  
Nick Kootsouradis.....Assistant Superintendent School Operations

## School Board Members

Cathy Thigpen..... District 4  
Cindy Frakes..... District 1  
Melissa Thrush..... District 5  
Dewey Destin..... District 2  
Rodney Walker..... District 3

## CHS Leadership Team

Bob Jones.....Principal  
Dexter Day..... Assistant Principal  
Ella Shaw..... Assistant Principal  
Brandon McSween..... Assistant Principal  
Tim Hatten..... Athletic Director  
Thomas Harvell.....Dean of Discipline

## Guidance Department

Keitha Holloway.....Counselor  
Karen Jeannette.....Counselor  
Ashley Terry.....Counselor

## Important Phone Numbers

Main Switchboard ..... 689-7177  
Administrative Offices .....ext. 2320  
Attendance.....ext. 2260 / 2261  
Discipline.....ext. 2400  
Guidance.....ext. 3270  
Media Center .....ext. 2410  
School Nurse .....ext. 2390

# CRESTVIEW HIGH SCHOOL

## 2014-2015 9<sup>TH</sup> GRADE

### REGISTRATION INSTRUCTIONS FOR STUDENTS

As a student enrolled in Crestview High School, you are given the opportunity to select coursework each spring for the following year. It is important that you involve your parents in course selection, that you make certain you meet the prerequisites, and that you keep high school graduation requirements and career objectives in mind. This guide is designed to aid you in making appropriate choices by providing brief program and course descriptions, prerequisites, and other information related to this process. In order to complete registration successfully, you are urged to follow the steps below:

1. READ the curriculum guide carefully
2. REVIEW the list of graduation requirements and determine which requirements have been met and which courses need to be taken next year
3. TALK to your parents and teachers about course selections and appropriate academic levels that will allow you to experience optimal success
4. SELECT courses that align with your goals for the future. Course selection represents a commitment on the part of the student and parent to complete the schedule of classes chosen. Therefore, students and parents should remember to weight carefully the student's past performance, teacher recommendations, ability, motivation, and extra-curricular activities when selecting courses for the coming year.
5. SPECIAL NOTE: It is expected that all 9<sup>th</sup> grade students scoring at or above a level 2 on the 8<sup>th</sup> grade FCAT Reading test be enrolled in at least ONE honors-level course. Students are encouraged to select the subject area in which their performance is traditionally strongest.

Due to Florida's Core Class-Size Amendment, schedule change requests will be considered only for the following reasons:

- a. Scheduling error (example – request English 1 and receive English I Hon)
- b. Failure to complete a prerequisite course or requirement
- c. Graduation or college requirement omitted from schedule
- d. Special programs requiring unique schedules
- e. Summer school course completion

**Important: The administration reserves the right to make necessary changes at any time during the school year based on changing school enrollment, class size, and teacher load as determined by the State of Florida Core Class-Size Amendment requirements.**

Due to class size amendment, these policies will be strictly enforced. Students should not expect to be able to change a schedule or course request after the first 10 days of the fall semester. All students who drop a class after the first 4 weeks of school will receive a penalty "F".

In order to be considered an Honors Graduate, *students must be enrolled in the same year-long course at the same level and receive a grade for the 8<sup>th</sup> semester or have completed their (4) required courses by the end of the 7<sup>th</sup> semester.* (High school courses taken in middle school count in the determination of honor graduate status (e.g., core, foreign language, elective).

# GUIDANCE OFFICE

## Parent/Teacher Communication

If a student is experiencing a problem in a course, the best solutions are a result of direct communication between the parent, student and teacher. Please call or e-mail the instructor with your concerns and allow at least 24 hours for a response. E-mail addresses can be found on the school web site. You may also arrange for a conference with a guidance counselor and your student's teachers by contacting Guidance to schedule an appointment.

## School Website

Crestview High School Website is: [www.crestviewbulldogs.org](http://www.crestviewbulldogs.org)

## Grades Online

Your student's grades can be found online at: [www.okaloosaschools.com](http://www.okaloosaschools.com)

## Promotion Criteria

Students must earn a minimum number of credits each year in order to be promoted to the next level:

- Grade 9 – A minimum of 6 Credits
- Grade 10 – A minimum of 12 Credits
- Grade 11 – A minimum of 17 Credits

Grade	Percent	Definition	Grade Point Value Non-weighted	Grade Point Value Weighted: IB, AP, district approved Dual Enrollment, CHOICE courses receiving college credit	Grade Point Value Weighted: all other district approved weighted courses
A	90-100	Outstanding Progress	4	5	4.5
B	80-89	Above Average Progress	3	4	3.5
C	70-79	Lowest Acceptable Progress	2	3	2.5
D	60-69	In Danger of Failing	1	2	1.5
F	0-59	Fail	0	0	0
I	0	Incompl.	0	0	0

## REQUIREMENTS FOR HIGH SCHOOL GRADUATION

**In order to graduate from high school in the State of Florida, a student must have the following:**

- 1) A passing score (currently 245) on the reading FCAT 2.0.**
- 2) 24 credits or 18 credits**
- 3) A minimum cumulative Grade Point Average (GPA) of 2.0.**
- 4) Receive a passing score on the EOC Assessment requirements for his/her cohort year.**

# REQUIREMENTS FOR HIGH SCHOOL GRADUATION

## STUDENTS ENTERING GRADE NINE IN 2014-2015 SCHOOL YEAR

### Graduation Requirements

Subject Area	24 Credit Program	Three Year, 18 Credit College Preparatory Program
English	4 credits with major concentration in composition, reading for information, and literature	4 credit with major concentration in composition and literature
Mathematics	4 credits, one of which must be Algebra 1 or its equivalent, and one of which must be Geometry or its equivalent. <ul style="list-style-type: none"> <li>■ Industry certification courses that lead to college credit may substitute for up to 2 mathematics credits</li> </ul>	4 credits, one of which must be Algebra I or its equivalent or a higher-level mathematics courses from the list of courses that qualify for State University System (SUS) admission, and one of which must be Geometry or its equivalent <ul style="list-style-type: none"> <li>■ Industry certification courses that lead to college credit may substitute for up to 2 mathematics credits</li> </ul>
Science	3 credits in science, two of which must have a laboratory component <ul style="list-style-type: none"> <li>■ Industry certification courses that lead to college credit may substitute for up to 1 science credit</li> </ul>	3 credits in science, two of which must have a laboratory component <ul style="list-style-type: none"> <li>■ Industry certification courses that lead to college credit may substitute for up to 1 science credit</li> </ul>
Social Studies	1 credit World History 1 credit U.S. History .5 credit U.S. Government .5 credit Economics to include financial literacy	1 credit World History 1 credit U.S. History .5 credit U.S. Government .5 credit Economics
World Language	Not required for high school graduation; but required for admission into state universities	Not required for high school graduation; but required for admission into state universities
Fine Arts and Performing Arts, Speech and Debate, or Practical Arts	1 credit in Fine or Performing Arts, Speech and Debate, or Practical Arts (eligible courses specified in Course Code Directory)	1 credit in Fine or Performing Arts, Speech and Debate, or Practical Arts (eligible courses specified in Course Code Directory)
Physical Education	1 credit in Physical Education to include the integration of Health	Not Required
Electives	8 credits  <b>ONE ONLINE COURSE IS REQUIRED</b>	3 credits
<b>Total</b>	<b>24 credits</b>	
Grade Point Average (GPA) Requirements	Cumulative GPA of 2.0 on a 4.0 scale	
State Assessment Requirements	<ul style="list-style-type: none"> <li>• Passing scores on the Grade 10 FCAT 2.0 Reading or scores on a standardized passing scores on the FCAT 2.0 (ACT or SAT)</li> <li>• Algebra 1 EOC Assessment is required and the results will count as 30 percent of the final course grade, if enrolled.</li> <li>• The final grade for U.S. History or U.S. History Honors must include a minimum 30 percent of the U.S. History EOC Assessment, effective for students enrolled in the course in 2012-2013.</li> </ul>	
<b>Special Notes</b>		
<ul style="list-style-type: none"> <li>• All courses earned toward the three-year, 18-credit college preparatory program must satisfy admission requirements for the State University System. To determine which courses meet State University System admission requirements, please use the Comprehensive Course Table. At least 6 of the 18 credits must be completed in courses that include dual enrollment, AP, IB, AICE, or are specifically listed as rigorous by the Florida Department of Education.</li> </ul>		

# CHS Course Level Expectations

## GENERAL

- Students are expected to meet required standards of the course
- Expected Homework: 20-30 minutes day/course

## HONORS

- Grades of A or B in a regular or honors course (other pre-requisites may apply)
- FCAT scores at level 3 and above, Algebra I EOC "B" or higher (level 2 Reading or "C" on Algebra I EOC requires teacher recommendation)
- Students should be able to demonstrate a solid work ethic and good attendance
- Expected homework: 30-45 minutes day/course
- Summer assignments may be given by instructor

## ADVANCED PLACEMENT and AICE PROGRAM

- Grades of A or B in an honors level course in the subject area
- FCAT scores at level 3 and above for optimal success
- Students should be able to demonstrate a solid work ethic and good attendance
- Students will be required to analyze, synthesize, and evaluate information at the college level
- Expected homework: one hour day/course
- All students will sit for the AP or AICE exam for each course
- Summer assignments may be given by instructor

## Crestview High School Advanced Studies Program Course Offerings For 2014-15

	9 <sup>th</sup> Grade	10 <sup>th</sup> Grade	11 <sup>th</sup> Grade	12 <sup>th</sup> Grade
<b>English</b>	<ul style="list-style-type: none"> <li>English I Honors</li> </ul>	<ul style="list-style-type: none"> <li>English II Honors/AICE General Paper</li> </ul>	<ul style="list-style-type: none"> <li>AP Language and Composition</li> </ul>	AP Literature and Composition
<b>Math</b>	<ul style="list-style-type: none"> <li>Algebra I Hon</li> <li>Geometry Hon</li> <li>Algebra II Hon</li> </ul>	<ul style="list-style-type: none"> <li>Geometry Hon</li> <li>Algebra II Hon</li> <li>Pre-Calculus</li> </ul>	<ul style="list-style-type: none"> <li>Algebra II Hon</li> <li>Pre-Calculus</li> <li>AP Calculus AB</li> <li>College Algebra</li> <li>AP Statistics</li> </ul>	<ul style="list-style-type: none"> <li>Pre-Calculus</li> <li>AP Calculus AB</li> <li>AP Calculus BC</li> <li>AP Statistics</li> <li>College Algebra</li> </ul>
<b>Social Studies</b>	<ul style="list-style-type: none"> <li>Pre-AICE World History</li> <li>AP World History</li> </ul>	<ul style="list-style-type: none"> <li>AP European History</li> </ul>	<ul style="list-style-type: none"> <li>AP US History</li> </ul>	<ul style="list-style-type: none"> <li>AP US Government</li> <li>AP Macroeconomics</li> </ul>
<b>Physical and Biological Science Focus</b>	<ul style="list-style-type: none"> <li>Pre-AICE Biology (required)</li> <li>AP Environmental Science</li> </ul>	<ul style="list-style-type: none"> <li>AP Environmental Science</li> </ul>	<ul style="list-style-type: none"> <li>Physics I Hon</li> <li>AP Physics 1</li> <li>AP Environmental Science</li> <li>Marine Science Hon</li> <li>Anatomy/Phys Hon</li> </ul>	<ul style="list-style-type: none"> <li>Physics I Hon</li> <li>AP Physics 1</li> <li>AP Physics 2</li> <li>AP Environmental Science</li> <li>Marine Science Hon</li> <li>Anatomy/Phys Hon</li> </ul>
<b>Chemical Science Focus</b>	<ul style="list-style-type: none"> <li>AP Environmental Science</li> </ul>	<ul style="list-style-type: none"> <li>AP Environmental Science</li> <li>Chemistry I Honors</li> </ul>	<ul style="list-style-type: none"> <li>AP Environmental Science</li> <li>Chemistry I Honors</li> </ul>	<ul style="list-style-type: none"> <li>AP Environmental Science</li> <li>AP Chemistry</li> </ul>
<b>Foreign Language</b>	<ul style="list-style-type: none"> <li>Spanish I Honors</li> <li>French I Honors</li> </ul>	<ul style="list-style-type: none"> <li>Spanish II Honors</li> <li>French II Honors</li> </ul>	Spanish III Honors French III Honors	Spanish IV Honors French IV Honors
<b>Elective</b>	<ul style="list-style-type: none"> <li>AP Human Geography</li> </ul>	<ul style="list-style-type: none"> <li>AP Human Geography</li> <li>AP European History</li> <li>AICE Critical Thinking Skills</li> <li>*AP Psychology</li> <li>*AP Studio Design 2-D</li> <li>*AP Studio Design 3-D</li> </ul>	<ul style="list-style-type: none"> <li>AP Human Geography</li> <li>AP European History</li> <li>AICE Critical Thinking Skills</li> <li>AP Psychology</li> <li>AP Studio Design 2-D</li> <li>AP Studio Design 3-D</li> </ul>	<ul style="list-style-type: none"> <li>AP Human Geography</li> <li>AP European History</li> <li>AICE Crit. Thinking Skills</li> <li>AP Psychology</li> <li>AP Studio Design 2-D</li> <li>AP Studio Design 3-D</li> </ul>

AP= Advanced Placement

AICE= Advanced International Certificate of Education

\*Selected students only.





**Initial-Eligibility Standards for NCAA Division I College-Bound Student-Athletes Are Changing**

College-bound student-athletes first entering an NCAA Division I college or university on or after August 1, 2016, will need to meet new academic rules in order to receive athletics aid (scholarship), practice or compete during their first year.

**What are the New Requirements?**

Full Qualifier	Academic Redshirt	Nonqualifier
Complete 16 Core Courses: <ul style="list-style-type: none"> <li>• 10 of the 16 core courses must be complete before 7th semester (senior year) of high school.</li> <li>• 7 of the 10 core courses must be in English, Math, or Science.</li> </ul>	Complete 16 core courses.	Does not meet requirements for Full Qualifier or Academic Redshirt status.
Minimum Core-Course GPA of 2.3	Minimum Core-Course GPA of 2.0	
Meet the <i>Competition</i> sliding scale requirement of GPA and ACT/SAT score.*	Meet the <i>Academic Redshirt</i> sliding scale requirement of GPA and ACT/SAT score.*	
Graduate from high school.	Graduate from high school.	

**\*To view the Full Qualifier and Academic Redshirt sliding scales, refer to [www.eligibilitycenter.org](http://www.eligibilitycenter.org).**

**Full Qualifier:** A college-bound student-athlete may receive athletics aid (scholarship), practice and compete in the first year of enrollment at the Division I college or university.

**Academic Redshirt:** A college-bound student-athlete may receive athletics aid (scholarship) in the first year of enrollment and may practice in the first regular academic term (semester or quarter) but may NOT compete in the first year of enrollment. After the first term is complete, the college-bound student-athlete must be academically successful at his/her college or university to continue to practice for the rest of the year.

**Nonqualifier:** A college-bound student-athlete cannot receive athletics aid (scholarship), cannot practice and cannot compete in the first year of enrollment.

**Examples**

**Q:** *A college-bound student-athlete completes nine core courses prior to the seventh semester of high school. What is the college-bound student-athlete's initial-eligibility status?*

**A:** The college-bound student-athlete cannot be certified as a qualifier because only nine of the 10 required courses were completed before the seventh semester. He/she would be permitted to practice and receive aid (scholarship), provided he/she presents 16 core courses and meets the necessary core-course GPA and test score requirement at the time of graduation.

**Q:** *A college-bound student-athlete completes 16 core courses in the required framework with a 2.500 core-course GPA and a 68 sum ACT. What is the college-bound student-athlete's initial-eligibility status?*

**A:** The college-bound student-athlete is an academic redshirt. Under the new competition scale, a 68 sum ACT score requires a 2.950 core-course GPA. **For sliding scale, refer to [www.eligibilitycenter.org](http://www.eligibilitycenter.org).**

**Q:** *A college-bound student-athlete completes 15 core courses with a 2.500 core-course GPA and an 820 SAT score (critical reading and math). What is the college-bound student-athlete's NCAA initial-eligibility status?*

**A:** The college-bound student-athlete is a nonqualifier because only 15 core courses were completed, not the required 16 core courses.

**For additional information on these requirements please visit: [www.eligibilitycenter.org](http://www.eligibilitycenter.org)**

# TESTING INFORMATION

## Required Tests

### EOC EXAMS – End of Course Exams

- Please refer to the assessments required for the year a student enters 9th grade

### FCAT 2.0 Florida Comprehensive Assessment Test

Students must achieve a passing score on the Grade 10 FCAT 2.0 reading to meet graduation requirements.

- Given to all freshmen and sophomores in March/April
- Measures skills in reading

## Optional Tests

### ASVAB-Armed Services Vocational Aptitude Battery

- Given to juniors and/or seniors who pre-register

### PSAT/NMSQT- Preliminary Scholastic Aptitude Test and National Merit Scholarship Qualifying Test

- This test should be used for making decisions about classes for the last two years of high school
- For college bound juniors, the test is given in October for a fee
- This test is required of Juniors for consideration for National Merit Scholarships

### AP Exam - Advanced Placement Examination

- For students enrolled in AP courses
- Given in May for college credit (free of charge)
- Exam does not affect grade earned in class

### ACT - [www.act.org](http://www.act.org)

- College bound students may take as part of college entrance requirements
- **Students should be near the completion of Algebra II before taking this test**
- Measures performance in English, Mathematics, Reading and Science Reasoning, Writing optional
- Testing dates are in September, October, December, February, April, and June
- Fee requirement; must register on-line or by mail six weeks in advance
- Registration materials for dates, times, and locations of administration can be picked up in Guidance
- Required for Bright Futures eligibility (or SAT)

### SAT- Scholastic Aptitude Test of the College Board –[www.collegeboard.com](http://www.collegeboard.com)

- College bound students may take as part of college entrance requirements
- **Students should be near the completion of Algebra II before taking this test**
- Required for consideration as National Merit Scholarship Finalist
- Measures performance in Mathematics, Critical Thinking and Writing abilities
- Fee requirement; must register on-line
- Required for Bright Futures eligibility (or ACT)

### PERT- Post Secondary Education Readiness Test

- Community College bound students. No Fee
- Does not meet college placement test requirement for Bright Future eligibility other than Gold Seal
- Given weekly at Northwest Florida State College. Used for placement for some high school courses

### AICE Advanced International Certificate of Education

- Mandatory for students enrolled in AICE classes
- Given in May and June for college credit depending on score earned
- Does not affect grade earned in class

# SPECIAL PROGRAMS

## Advanced Placement Program

AP stands for Advanced Placement. Advanced Placement (AP) is a program of college level courses and exams that gives bright, motivated students the opportunity to get ahead by earning advanced placement and/or college credit while they are still in high school.

### **Advanced Placement courses available at Crestview High School**

2106420	AP U.S. Government		
2100330	AP U.S. History		AP Physics 1
1001430	AP English Literature		AP Physics 2
1001420	AP English Language	2109380	AP European History
2109420	AP World History	2102370	AP Macroeconomics
1202310	AP Calculus AB	2103400	AP Human Geography
1202320	AP Calculus BC	2107350	AP Psychology
2003370	AP Chemistry	0109350	AP Studio/2-D
1210320	AP Statistics	0109360	AP Studio/3-D

**All students enrolled in an AP class will take the AP Exam at the end of the school year.**

## Advanced International Certificate of Education (AICE)

The AICE program is an international Diploma that students can earn via an advanced academic curriculum and assessment program written and administered by a non-profit department of the University of Cambridge in England. For over 160 years the prestigious University of Cambridge has been setting worldwide standards through their examinations. Passing grades available on AICE exams range from A to E with A being the highest. Performance of students below the threshold of a CIE grade of E receive a grade of U, ungraded, which is not considered as passing. A CIE grade of E most closely correlates with an Advanced Placement exam grade of 3 and a US grade of C. All public universities and community colleges in Florida award up to 30 hours of college credits for AICE exams passed.

### **AICE courses available at Crestview High School:**

1009360	General Paper
1700372	Thinking Skills

**All students enrolled in an AICE class will take the AICE Exam at the end of the school year.**

## Virtual School

Florida HB7067 (Section 4, Section 1002.45) requires each school district within the state of Florida to provide eligible students within its boundaries the option of participating in an online (or "virtual") instruction program. For information regarding our Florida Virtual School franchise, contact the director at 833-3533.

## Dual Enrollment – Northwest Florida State College and the University of West Florida

NWFSC and UWF offer college level instruction for students during the school year and in the summer for students in grades 10-12. Students who are eligible to participate in these courses shall meet the following requirements:

- Cumulative unweighted grade point average of 3.0 or above on all course work beginning with the 9th grade
- Student **must** pass the appropriate subtest of the PERT, ACT, or SAT if enrolling in a Gordon Rule course.

# SCHOLARSHIPS

## Florida Bright Futures Scholarship

Offered by the State of Florida, the Florida Bright Futures Scholarship Program provides scholarships to Florida's high school seniors who qualify under one of the three scholarship programs: **The Florida Academic Scholars Award**, **The Florida Medallion Scholars Award**, and **The Florida Gold Seal Vocational Scholars Award**. Each of the three scholarship programs has specific criteria that must be met.

The general eligibility requirements for an initial award from any of the three scholarships include:

- Complete a Florida Financial Aid Application online at [www.floridastudentfinancialaid.org](http://www.floridastudentfinancialaid.org) by the end of the second semester of the student's senior year (no earlier than December 1)
- Submit a Free-*Application for Federal Student Aid (FASA)* @ [www.fafsa.ed.gov](http://www.fafsa.ed.gov)
- Be a Florida resident
- Earn a Florida standard high school diploma, or its equivalent
- Be accepted by, and enrolled in, an eligible Florida public or independent post secondary education institution
- Enroll in a post secondary institution in Florida for at least six semester credit hours, or the equivalent each semester
- Not have been found guilty of, or have pled nolo contendere to, a felony charge
- Begin using the award within three years of graduation

The Florida Legislature is authorized to change eligibility and funding for future graduating classes

View additional information regarding all Florida Bright Futures Scholars programs at [www.floridastudentfinancialaid.org](http://www.floridastudentfinancialaid.org)

## **Florida Medallion Scholars for the Graduating Class of 2014**

The Florida Medallion Scholars Award provides a specified award amount established by the Florida Legislature for college tuition and fees at a Florida public post secondary education institution or a fixed award amount based on the average tuition and fees at a comparable private institution.

The 2014 eligibility requirements for the Florida Merit Scholars Award include:

- Un-rounded, weighted (under state weighting system for scholarships) 3.0 cumulative GPA in the 16 core credits (4 English, 4 Math [Algebra I or higher], 3 Science, 3 Social Studies, and 2 of the same Foreign Language)
- Has earned a score of 1070 on SAT or 26 on ACT
- Student has completed 75 hours of community service



# SCHOLARSHIPS

## Renewal of Award

The Florida Academic Scholars Award is renewable yearly as long as a student maintains a 3.0 GPA. The Florida Medallion Scholars Award is renewable yearly as long as a student maintains a 2.75 GPA.

## Florida Academic Scholars for the Graduating Class of 2014

The Florida Academic Scholars Award provides a specified award amount established by the Florida Legislature for college tuition and fees at any of the Florida public post-secondary education institutions or a fixed award amount based on the average tuition and fees at a comparable private institution.

The 2014 eligibility requirements for the Florida Academic Scholars Award are:

- Un-rounded, weighted (under state weighting system for scholarships), 3.5 cumulative GPA in the 16 core credits
- Has earned a score of 1290 on SAT or 29 on ACT
- Student has completed 100 hours of community service

## Florida Gold Seal Scholars for the Graduating Class of 2014

Students must complete a specific 3 course block of vocational courses, earn a 3.5 GPA in those courses, have a 3.0 GPA in the required 15.5 core courses, and earn qualifying scores on either the PERT, CPT, SAT, or ACT. Students must complete a minimum of 30 hours of community service. It is awarded for up to 2 years, pays a specified award amount of tuition and fees to state institutions and a comparable amount to private schools.

**NOTE: These requirements are subject to change with each legislative session.**



## Awards & Honors Graduation Criteria

A District weighted grade point average will be used to calculate class rank and honors designations.

A district-weighted grade point average will be used to calculate class rank and honors designations for standard diploma students. However the determination of the top 1% of students will be based on cumulative GPA.

At the end of the seventh semester for 24-credit graduates and the end of the fifth semester for the 18-credit graduates, honor graduates will be determined by the following scale:

<i>Summa Cum Laude</i>	<i>Magna Cum Laude</i>	<i>Cum Laude</i>
4.5 and above	4.2 – 4.49	4.0 – 4.19

In order to be considered an honors graduate, students must be enrolled in the same year-long course at the same level and receive a grade for the eighth semester or have completed their four (4) required courses by the end of the seventh semester. It is policy that students must complete 4 credits of Math and Science in grades 9-12.

24-Credit Graduates - At the end of the seventh semester, honor graduates will be determined by averaging the following highest 19 credits:

- 3.5 English Credits
- 3.5 Social Science Credits
- 3.5 Math Credits
- 3.5 Science Credits
- 1.5 Foreign Language Credits of the same language
- 3.5 Elective Credits
- 19.0 Total**

## Okaloosa County Academic Honors Ceremony

The Okaloosa County School Board honors its most successful senior students with a county-wide ceremony each year. Students are selected to attend based upon the following:

**Seniors:** All students who are deemed Honor Graduates (Summa Cum Laude, Magna Cum Laude, and Cum Laude)

The following students will be recognized at a ceremony at Crestview High School:

**Juniors:** All students with a 4.0 cumulative weighted GPA or higher or 3.9 un-weighted GPA or higher at the end of their 5<sup>th</sup> Semester.

**Sophomores:** All students with a 4.0 cumulative weighted GPA or higher or 3.9 un-weighted GPA or higher at the end of their 3<sup>rd</sup> Semester.

**Freshman:** All students with a 4.0 cumulative weighted GPA or higher or 3.9 un-weighted GPA or higher at the end of their 1<sup>st</sup> Semester.

## 9TH GRADE ENGLISH

### 1001310 English I

1 year; 1 English credit; prerequisite: FCAT Reading level 1-3

The reading, writing, speaking and listening, and language skills for this class are career and college readiness skills.

### 1001320 English I Hon\*

1 year; 1 English credit; prerequisite: FCAT Reading level 3 or higher for optimal success

This class carries the literary and writing that is needed for students in upper level English classes. Expectations for reading and writing exceed those in English I.

## MATHEMATICS

### 1200370 – 1200380 ALGEBRA 1 BLOCK

Designed for students receiving a Level 1 on the Grade 8 Math FCAT and/or receiving a grade of "C" or lower in Math 8.

This is a two period block of intensive Algebra I math instruction. Student's will take Algebra 1A first semester and Algebra 1B second semester. At the completion of this course, all students will take the state mandated and created end of course (EOC) exam. Passing this EOC exam is a graduation requirement replacing the math requirement of FCAT.

### 1200310 Algebra I

Prerequisite(s):

"B" average M/J Math Advanced 3  
FCAT Math Level 3 or higher

This course will be a formal study of symbolic mathematics as a solid foundation for all other academic mathematics. Topics will include the language of algebra, solving equations with one and two variables, polynomials, and factoring functions and graphs. At the completion of this course, all students will take the state mandated and created end of course (EOC) exam. Passing this EOC exam is a graduation requirement replacing the math requirement of FCAT.

### 1200320 Algebra I Honors\*

Prerequisite(s):

"A" average in Pre Algebra or M/J Math Advanced 3  
FCAT Math Level 4 or higher

This course gives a rigorous in depth study of algebra and algebraic concepts and processes that can be used to solve a variety of real world mathematical problems. (Students who took Algebra I Honors in 8<sup>th</sup> grade and did not receive credit or made a "C" average or below should retake this course.) At the completion of this course, all students will take the state mandated and created end of course (EOC) exam. Passing this EOC exam is a graduation requirement replacing the math requirement of FCAT.

### 1206320 Geometry Honors\*

Prerequisites):

"A+" average in Algebra I OR "C+" average in Algebra I Honors

This course gives a rigorous in-depth study of geometry with emphasis on methods of proof and the formal language of mathematics. Honors Geometry also models the logic of business analysis through mathematics to ready the business leaders of tomorrow. Instruction is rapidly paced for the most advanced math student

### 1200340 Algebra II Honors\*

Prerequisite(s):

"C" average in both Geometry Honors and Algebra I Honors

Algebra II Honors gives an in-depth study of the topics of Algebra II with emphasis on theory, proof, and development of formulas, as well as their application. This course is for students going on to Pre-Calculus.





# MATH FLOW CHART

This flow chart is for students who enter 9<sup>th</sup> grade taking Algebra IA, Algebra I, or Algebra I Honors

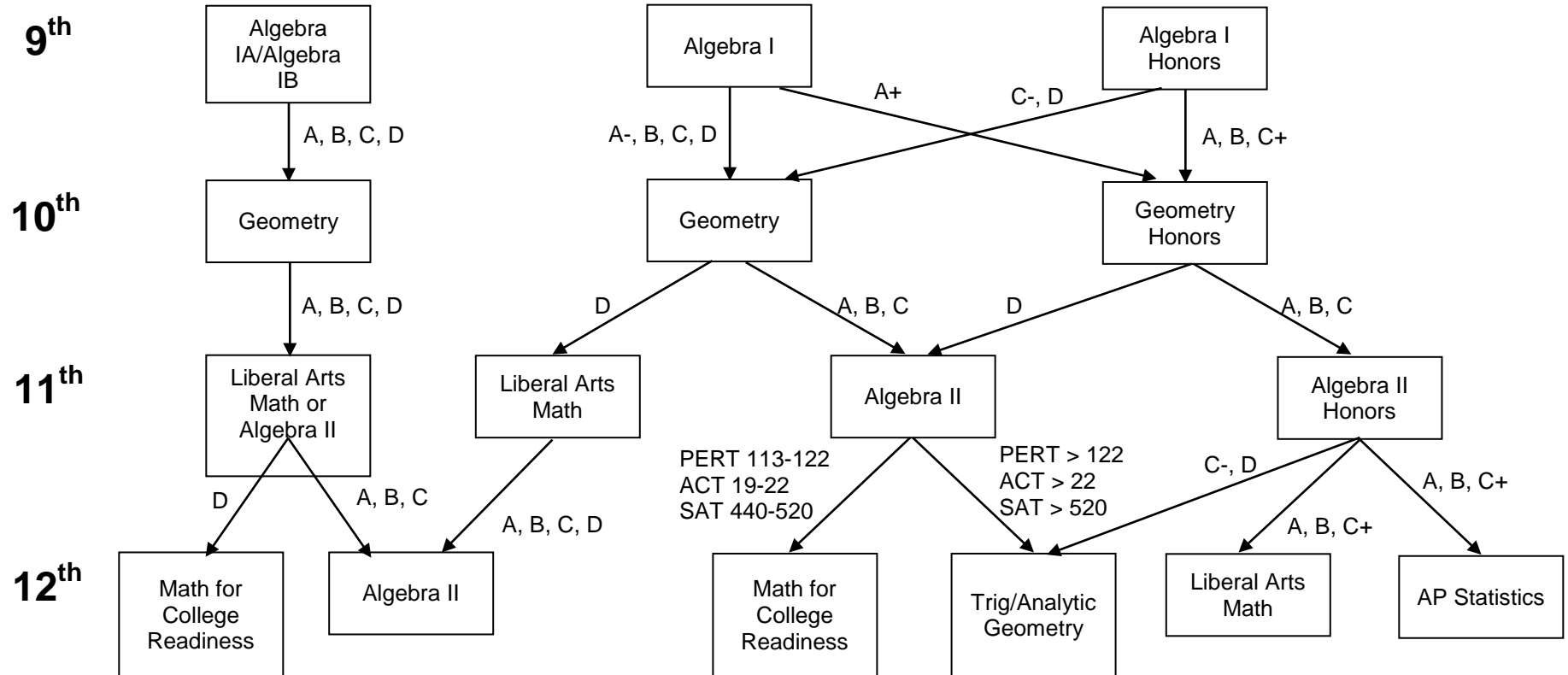

***Liberal Arts Math does not qualify for Bright Futures Academic or Medallion Scholarships.***

**Students who make a “D” in a math course are encouraged to retake the course for forgiveness.**

# MATH FLOW CHART

This flow chart is for students who enter 9<sup>th</sup> grade taking Algebra II Honors

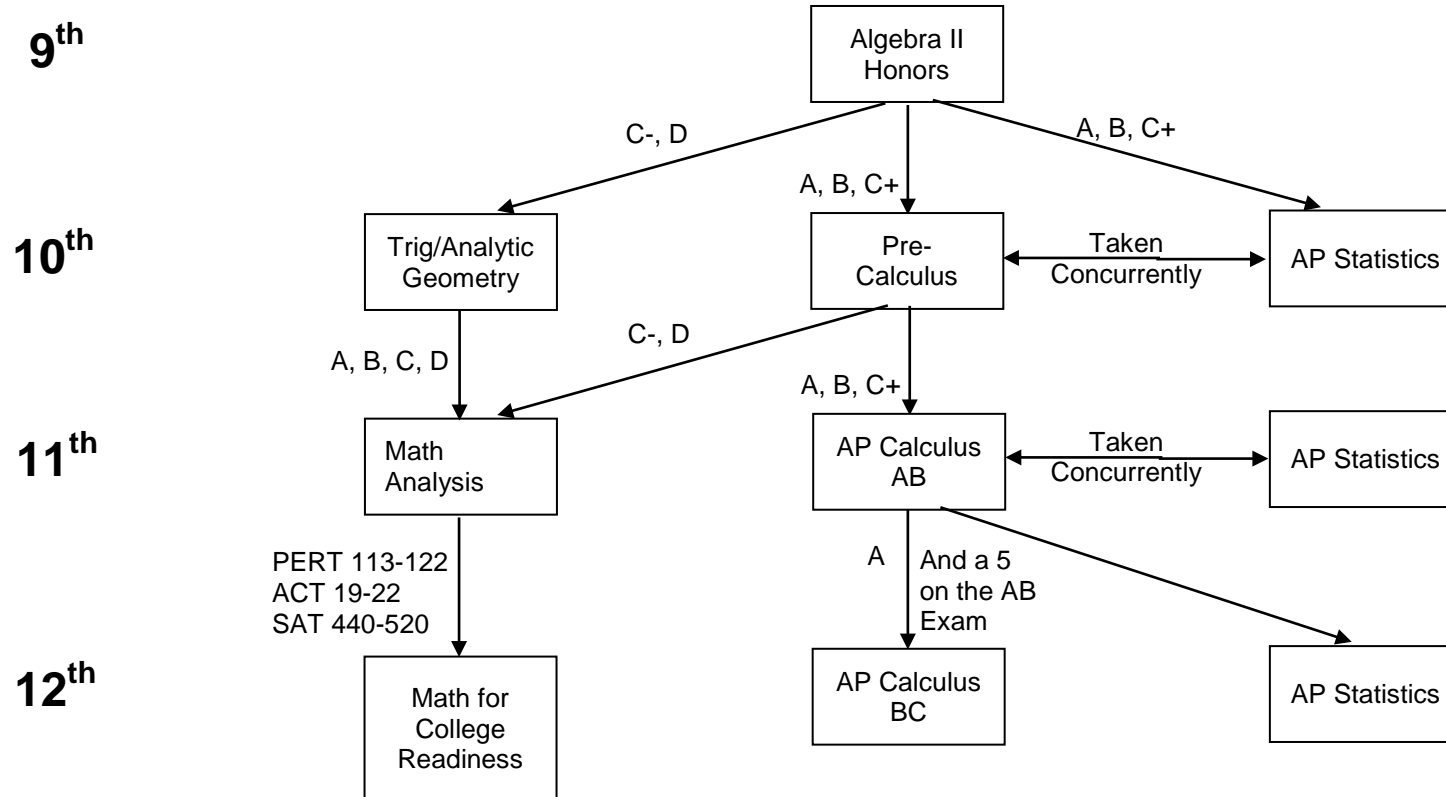

Students who make a “D” in a math course are encouraged to retake the course for forgiveness.

# MATH FLOW CHART

This flow chart is for students who enter 9<sup>th</sup> grade taking Geometry Honors

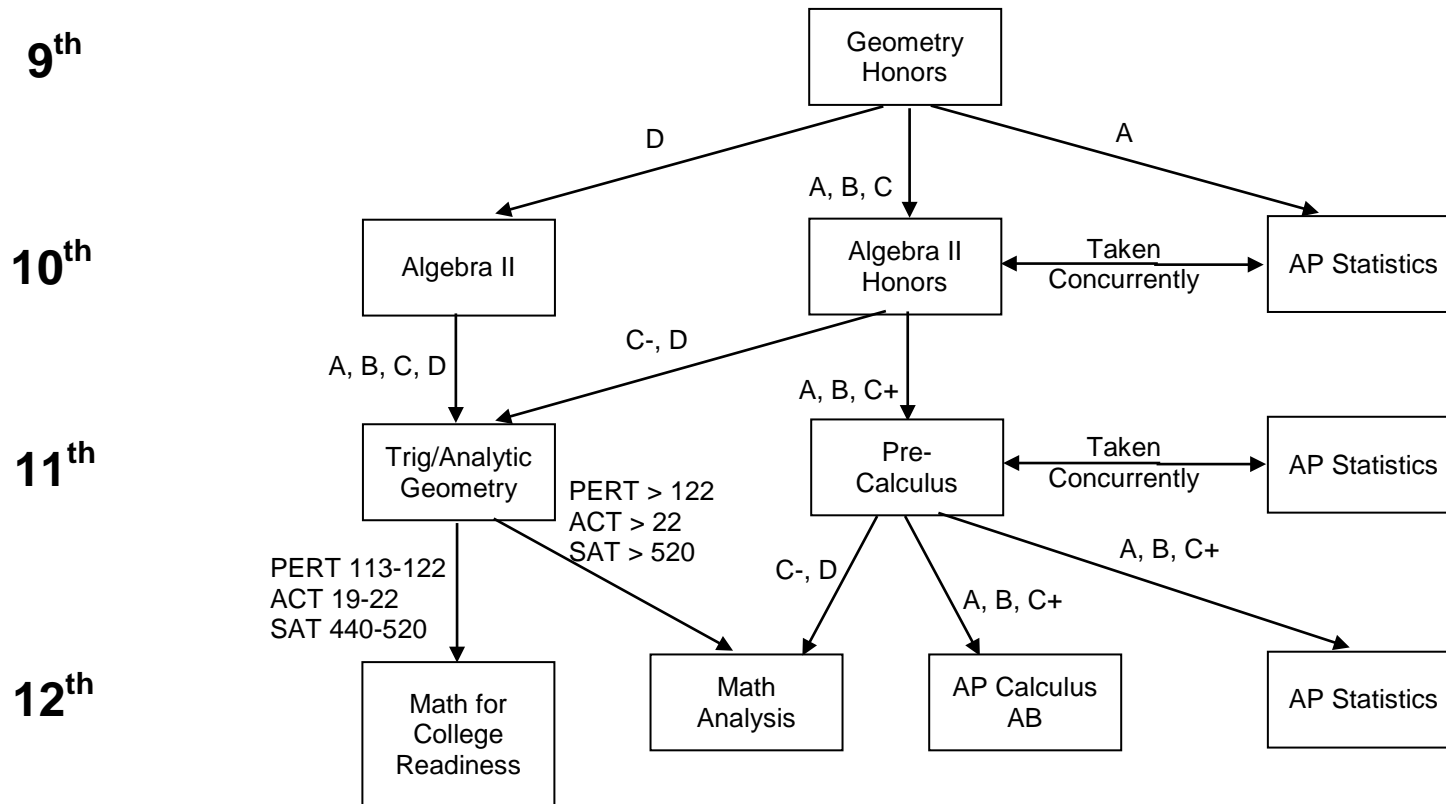

Students who make a “D” in a math course are encouraged to retake the course for forgiveness.

# SCIENCE

## 2000310 – Biology I (9<sup>th</sup> grade only)

*1 year, 1 credit, no prerequisite.*

Course covers exploratory experiences and activities in the fundamental concepts of life.

## 2000322 –Pre AICE Biology I\* (9<sup>th</sup> grade only)

*1 year, 1 credit, weighted; Prerequisite: Physical Science Honors 8<sup>th</sup> grade*

Provides advanced exploratory experiences and activities in the fundamental concepts of life, at a faster pace and on a more in-depth scale for the motivated, more independent student.

## 2001380 Advanced Placement (AP) Environmental Science\*

*Prerequisite(s): . . . 9<sup>th</sup> -12<sup>th</sup> grade*

*FC AT Reading Level 4 or 5*

*Teacher Recommendation and Application Required*

This course is a college-level course that provides students the scientific principles, concepts, and methodologies required to understand the inter-relationships of the natural world, to identify and analyze environmental problems both natural and human-made, to evaluate the relative risks associated with these problems, and to examine alternative solutions for resolving and/or preventing them. Students will take an exam at the end of the course which may earn them college credit. **MUST BE TAKEN CONCURRENTLY WITH PRE-AICE BIOLOGY**

All courses are one year - 1 credit courses unless noted otherwise. \*Denotes Weighted Courses



All courses are one year - 1 credit courses unless noted otherwise. \*Denotes Weighted Courses

# SCIENCE FLOW CHART

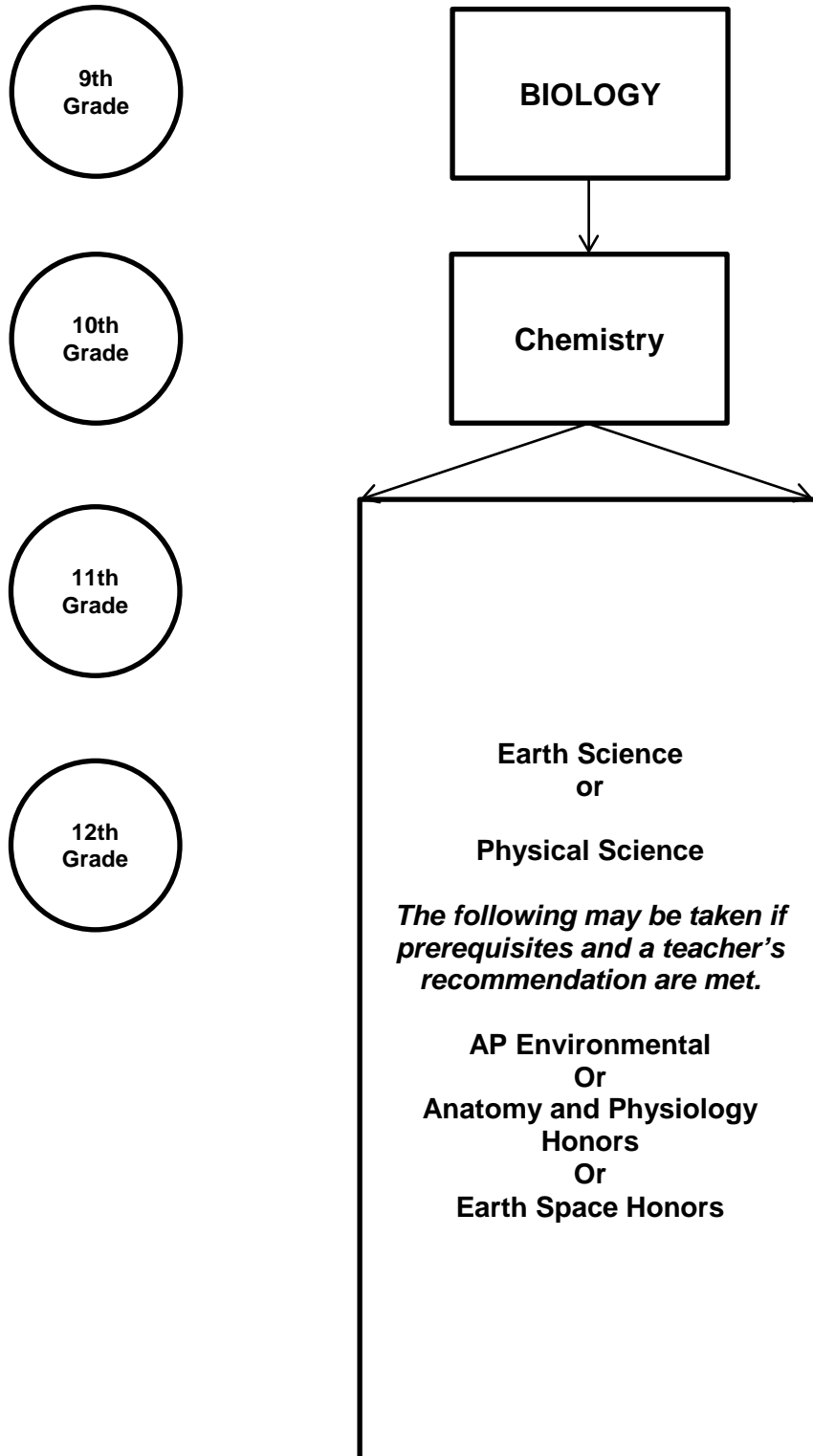

# HONORS SCIENCE FLOW CHART

## Honors Science Flow Chart

## Accelerated Science Flow Chart

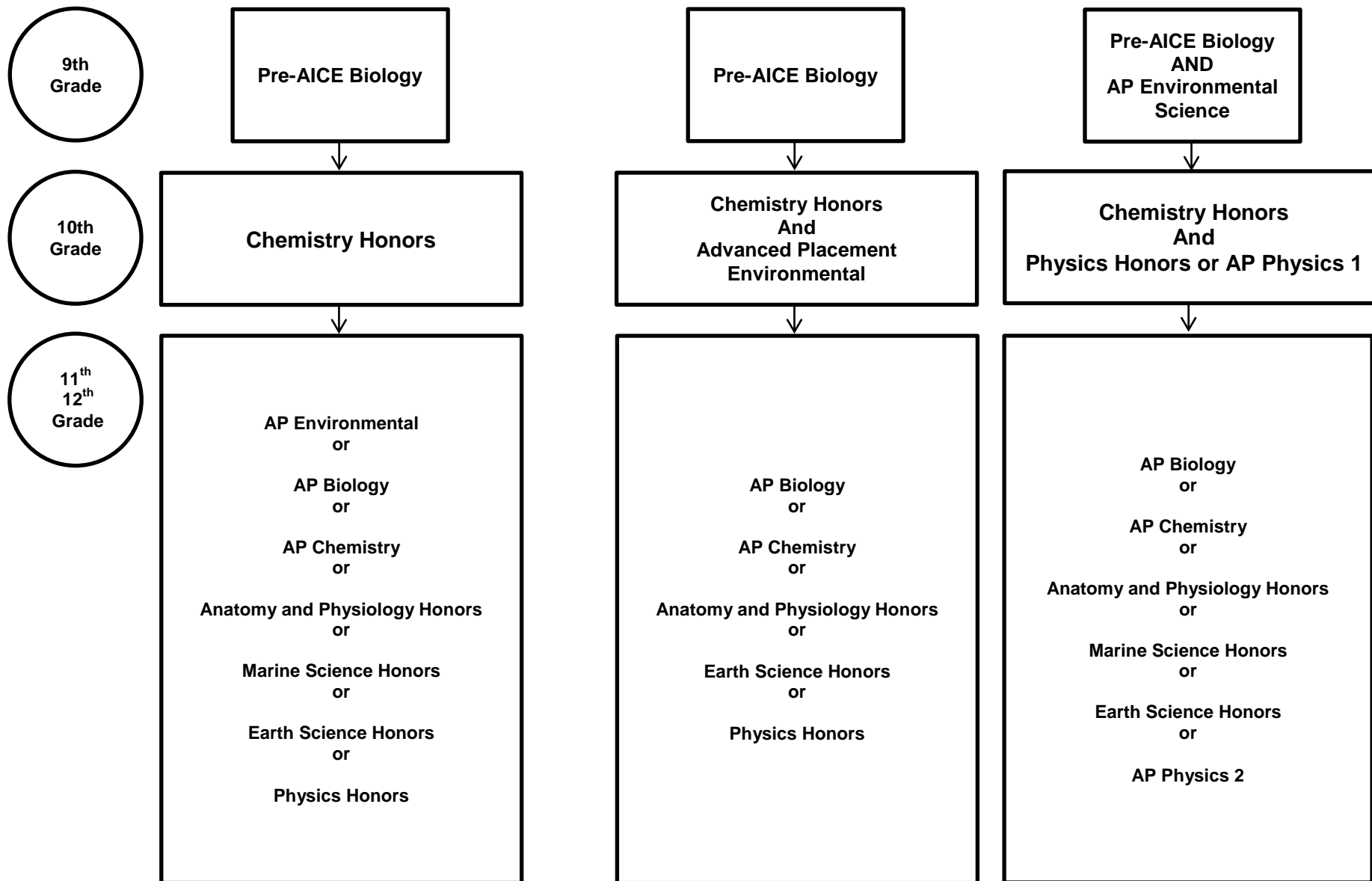

All courses are one year - 1 credit courses unless noted otherwise.

## 9TH GRADE SOCIAL STUDIES

### 2109310 World History

This course is a survey of historical development, stressing how past experiences affect present decisions of nations and individuals. First semester is a study of history and culture from the Byzantine Empire to the Age of Enlightenment. Second semester is a study of history and culture from the Age of Enlightenment to the present (Global Interdependence). Included in the content will be a mandated unit of study on the Holocaust. This course meets the graduation requirement.

### 2109321 Pre-AICE World History Hon\*

*Prerequisite(s):*

- *FCAT Reading Level 3 or higher*

This course is a survey of world history divided into two semesters. First semester will study history and culture from the Byzantine Empire to the Age of Enlightenment. Second semester will advance from the Age of Enlightenment to the present (Global Interdependence). Included in the content will be a mandated unit of study on the Holocaust. This course requires advanced reading and writing skills for the rigor of the material. This course meets the graduation requirement.

### 2109420 Advanced Placement (AP) World History\*

*Prerequisite(s): Application Required*

- *FCAT Reading Level 4*

This course is an intense study of historical development and an examination of the relationship of change and continuity across the periods of world history. Students use knowledge pertaining to history, geography, economics, political processes, religion, ethics, diverse cultures, and humanities to understand how global communities evolved. Students may earn college credit by qualifying on the required AP exam given at the end of the course. This course meets the graduation requirement.

### 2103400 Advanced Placement (AP) Human Geography\*

*Prerequisite(s): 9<sup>th</sup> -12<sup>th</sup> grade only/ FCAT Reading Level 4 /"B" average in 8<sup>th</sup> grade Social Studies / Application Required*

Students in Advanced Placement Human Geography will be exposed to a challenging college-level curriculum. Students will use a college textbook and follow a curriculum developed by college professors. At the end of the school year, students will take an Advanced Placement Human Geography Exam produced and graded by the College Board. For students scoring a "3" or better (out of "5") on this exam, many colleges will award college credit. (The score on this exam will not affect a student's grade in the course.) Specifically, AP Human Geography is the study of people from a spatial and ecological perspective. Students will think critically, read analytically, and write objectively about human geography topics in preparation for future advanced placement courses.



## SPECIAL PROGRAMS



### Advanced Placement

Advanced Placement (AP) courses are college level courses designed to academically stimulate and challenge high school students. At the end of the school year, students take an AP exam in their subject at no charge. The test is scored from 1 to 5, and students who earn a score of 3 or higher may receive college credit. CHS recommends that all college-bound students take *at least four AP courses before they graduate.*

#### GENERAL REQUIREMENTS FOR ADVANCED PLACEMENT COURSES:

- Strong study habits
- Level 3 FCAT score in Reading and 4 on Writing
- Grade of A or B in subject area.
- Desire to attend college.
- Willingness to commit to summer reading and preparatory work
- Appropriate classroom behavior.
- Excellent attendance and character.



### Army JROTC

The Crestview High School Junior Reserve Officer Training Corps (JROTC) Program is a citizenship program for high school students in the ninth through twelfth grades. The course is designed to develop personal, academic, and leadership skills essential for college and professional careers. Leadership, self-reliance, self-discipline, goal setting, and communication skills are emphasized. JROTC encourages students to become involved, informed and responsible members of the community.

Students that successfully complete one full year of JROTC may enter the military at one pay grade above the normal entry level and students that complete three or four years of JROTC may enter the military at two pay grades above the normal entry level.

Students who have completed four years in high school JROTC and are going on to college ROTC may be allowed to waive the first year of enrollment in the college ROTC program if not on a four year scholarship.

To enhance classroom lessons students may participate in after school and social activities that include field trips to military facilities and museums, drill and color guard, adventure and rifle teams, community service activities as well as a military ball.

Uniforms are issued and tailored at no cost to students. Students are required to keep uniforms clean and to wear them once a week. Students participate in regular inspections and are graded on their ability to wear the uniform correctly.

Students earn one elective credit for each year of JROTC. Completion of 2 years shall satisfy one-credit requirement in physical education and one-credit requirement in performing arts.



## CHOICE PROGRAMS



### Aviation Institute

Okaloosa County School District has partnered with Embry-Riddle Aeronautical University to provide a dual enrollment model that offers college credit, weighted high school credit, and FAA-approved training. While the 9<sup>th</sup> grade class is for high school credit only, 10<sup>th</sup> through 12<sup>th</sup> grade students will earn college credit (The 10<sup>th</sup> through 12<sup>th</sup> grade level courses are not college preparation: these are actual college courses taught by college professors at Crestview High School) and upon high school graduation will be issued a transcript by Embry-Riddle documenting all courses completed for transfer to any college.



### Information Technology

Regardless of the path that our students take following high school graduation, whether to attend college or join the work force, familiarity with basic typing and computer operation is a necessity.

Computer assisted presentations and typed assignments are common in most classes at CHS. The CHOICE: IT program extends from basic computer familiarity to Digital Design and a Web Design sequence. In addition, this program provides students the opportunity for national certification in multiple areas. Introduction to IT is a prerequisite course for all IT courses, and is a recommended elective to all students.



### Diversified Career Technology (DCT)

Diversified Career Technology is designed to provide students with selected occupational skills through employment-related instruction and leadership development. The concurrent on-the-job training/paid model supervised by the employer and OJT coordinator enables students to develop both academically and professionally. The Crestview High DCT program is respected throughout the community and offers community-donated scholarships to all 12<sup>th</sup> grade program participants.

The purpose of this program is to provide students with supervised on-the-job training. Also included as part of DCT is employment-related instruction to help the student comprehend and apply the expectations in the "world of work" environment. On-the-job training is required of all DCT students. Each student should have a part-time or full-time job before enrolling. However, students who have been unable to secure employment, but want to enroll in DCT can still apply. Interested students should contact Mr. Victor Long at 689-7177, extension 8080.



### Health Occupations Program

The Health Occupations program at Crestview High School is a four year sequence of courses for students interested in the medical field. The program teaches basic medical skills and knowledge, with the last year comprised of job shadowing and individually placed observation and internship opportunities at local medical offices and facilities. The "hands-on" portion of the program is designed to give students a wide and practical view of the medical profession outside the traditional classroom setting. At the senior level, students receive practical experience through internships and can apply for CNA training.

# CHOICE PROGRAMS



## Vocational Welding Program

Qualified welders are in high demand all over the world. The work of welders includes joining pipe sections for oil and natural gas pipelines, building ships, and working in a variety of industrial environments such as power plants, refineries, chemical plants and manufacturing facilities.

In the **Core Curriculum** you will learn the safety obligations of workers, supervisors and managers to ensure a safe workplace. You will review the role of company policies and Occupational Safety and Health Administration (OSHA) regulations in maintaining a safe work place. There is basic mathematical functions, such as adding, subtracting, dividing and multiplying whole numbers, fraction, and decimals and explain their applications to the construction trades. Introduces you to hand and power tools that are used in the construction industry, such as hammers, saws, levels, vises, drills, grinders and sanders. This course will explain and familiarize you with the components of different types of blueprint drawings (civil, architectural, structural, mechanical, plumbing/piping and electrical) and instruct you on how to interpret and use drawing dimensions. This course provides you with techniques for communicating effectively with co-workers and supervisors. You will also learn the roles of individuals and companies in the construction industry. You will learn how to fill out employment applications, accident reports and develop a list detailing how employees can affect their company's profitability and its ability to reward employees.

In **Level One Welding**, we will cover welding safety equipment, protective clothing and procedures applicable to the cutting and welding metals. You will be trained on and be able to use the Oxyfuel cutting equipment. You will learn to clean and prepare all types of base metals for cutting and welding and identify and explain weld imperfections and causes. We will describe SMAW welding and how to connect welding current and setup arc welding equipment. You will make stringer, weave and overlapping beads and fillet welds, on groove joints with and without backing. You will use pipe fitting equipment and make welds on pipe. All welding will be done in several positions such as flat, horizontal, vertical and overhead.

In **Level Two Welding**, you will identify, interpret and draw symbols on drawings, and identify and explain welding detail drawings. You will be welding on stainless steel and aluminum in this level in flat, horizontal, vertical and the overhead positions. You will use both the Air Carbon Arc Cutting and the Plasma Arc Cutting equipment. This level lets you use the Gas Metal Arc Welding (GMAW) MIG on mild carbon steel, aluminum and stainless steel metal. You will also be using the Gas Tungsten Arc Welding (GTAW) TIG on mild carbon steel, aluminum and stainless steel in all positions.

In **Level Three Welding**, it gets you into the preheating and post weld heat treatment of metals, along with the physical characteristics and mechanical properties of the metals. You will also be using the Flux Cored Arc Welding (FCAW) on pipe in all positions. There is GMAW-Gas Metal Arc Welding and GTAW - Gas Tungsten Arc Welding on stainless steel and aluminum pipe in all positions

After successful completion of each Level of Welding, you will receive a National Center for Construction Education and Research (NCCER), Level I, II, III Welding Certificate and an AWS Entry Level Certificate.

Upon successful completion of the Core Curriculum, you will receive the National Center for Construction Education and Research (NCCER) CORE Curriculum completion certificate.

This program also offers the Occupational Safety and Health Administration (OSHA) 10 hour card, after completing a three week course and passing the examination test.

\*Steel Toe Boots required

## CHOICE PROGRAMS



### Vocational Electrical Program

The training students will receive is based on the current edition of the National Electrical Code and the National Center for Construction and Education and Research (NCCER). The national electrical code is the most widely recognized code used worldwide. It is updated every three years. The certificates students are able to obtain are Core Curriculum Levels I-IV in electrical as well as a ten hour OSHA certification. The areas covered are electrical safety, hand-bending, fasteners and anchors, electrical theory one, electrical theory two, introduction to the National Electrical Code, raceways, boxes and fittings, conductors, and electrical blueprints. We focus on residential wiring, and we also teach commercial and industrial wiring. The plan for electrical wiring provides a certificate for each level. Each level is a building block in the process of learning skills in the electrical trade areas. The beginning levels cover basic principles and the advanced levels go into higher levels of performance and ability. Students begin electrical wiring and learn basic skills that they can use not only in the workforce but in their personal projects from fixing a plug to hanging a ceiling fan. The higher levels enable them to achieve advanced levels of electrical application. Each level requires successful scores on each module of the NCCER test. The student must obtain a score of 70 or above on each module in order to receive certification. To meet individualized needs, the program allows for students to be provided multiple attempts in achieving success on the NCCER tests. Highly Qualified and Certified Instructor.

\*Steel Toe Boot or Tennis Show required



### Culinary Arts Institute

The CHS Culinary Arts Institute is designed for students pursuing employment in the food service industry or entry into a college or vocational school program in the culinary field. First started in 2003 in response to local industry and student interest, the program is a four-year plan of study that provides a "hands-on" approach to learning basic and specialized skills in the food industry.

Culinary students cater many events at CHS and in the community each year, including the Crestview Rotary Club. The program also includes presentations from chefs, culinary instructors and guest speakers. Students in the 11<sup>th</sup> and 12<sup>th</sup> grade may compete in state culinary competitions and work towards National Pro Start<sup>®</sup> certification. The Pro Start program offers a national culinary certification which provides college credit at certain college/vocational school culinary programs. Interested students may contact Mrs. Paula Knight at 689-7177, extension 3220.



### SSTRIDE FSU Pre-Medical Program

Crestview High School has partnered with the Florida State University College of Medicine to offer one of only four SSTRIDE pre-medical programs in the State of Florida. SSTRIDE students take core and health career courses that have been developed in conjunction with FSU in order to best prepare students for admission and success at FSU. Throughout the four years of the program, students will participate in medical field trips, guest speakers and trips to the FSU campus. In addition, students receive ACT test preparation and assistance in the college admissions process. The program is limited access, and should be considered by students who are interested in the medical career field and in attending Florida State University.



# Automotive Service Technology

ASE / NATEF accredited program Automotive Service Excellence / National Automotive Technicians Education Foundation

INSTRUCTOR - Mr. Darryl Brooks – Room 603 – 850-689-7177 ext. 6030

**Students need to register for 3 class periods to be blocked together. i.e. Periods 1,2,3 or 4,5,6**

Two period blocks considered on individual basis. One period registration will be considered and accepted only if/when room permits. All courses are 1 year, 1 credit, Grades 9-12.

- I. **PURPOSE:** The purpose of this program is to prepare students for employment and/or specialized training in the automotive industry. This program focuses on broad, transferable skills and stresses understanding and demonstration of the following elements of the Automotive industry; planning, management, finance, technical and product skills, underlying principles of technology, labor issues, community issues and health, safety, and environmental issues.
- II. **PROGRAM STRUCTURE:** This program is a planned sequence of instruction consisting of twelve courses with nine (9) occupational completion points. The Automotive Service Technology Program provides for 8 occupational areas (automotive repair specialization). This structure will allow students who successfully complete specified competencies to exit for employment or continue with specialized training.
- III. **LABORATORY ACTIVITIES:** Shop or laboratory activities are an integral part of the Automotive Technology program. These activities provide instruction in the use of automotive service equipment, tools, materials and processes found in the automotive service industry.

**Cooperative training – OJT:** Internship and Industrial Cooperative Education programs available to students that qualify.

Course #	Course Title	Length
8709410	Automotive Service Technology 1	1 credit
8709420	Automotive Service Technology 2	1 credit
8709430	Automotive Service Technology 3	1 credit
8709440	Automotive Service Technology 4	1 credit
8709450	Automotive Service Technology 5	1 credit
8709460	Automotive Service Technology 6	1 credit
8709470	Automotive Service Technology 7	1 credit
8709480	Automotive Service Technology 8	1 credit
8709490	Automotive Service Technology 9	1 credit
8709491	Automotive Service Technology 10	1 credit
8709492	Automotive Service Technology 11	1 credit
8709493	Automotive Service Technology 12	1 credit

Occupational Completion Point	Certification Title
A	Automobile Services Assistor
B	Engine Repair Technician
C	Automatic Transmission and Transaxle Technician
D	Manual Drive train and Axle Technician
E	Automobile Suspension and Steering Technician
F	Automotive Brake System Technician
G	Automotive Electrical/Electronic System Technician
H	Automotive Heating and Air Conditioning Technician
I	Automotive Engine Performance Technician

\* Steel Toe Boot required

# Okaloosa Aerospace Academy

## A partnership between Okaloosa Schools and Embry-Riddle Aeronautical University-Worldwide.

**Note 1:** The first listing (course 8600510) is for incoming freshmen, is high school credit only and is taught by an Okaloosa County School District faculty member. The freshmen class is NOT a prerequisite for upper-class aviation courses; students can step into Embry-Riddle Aeronautical University Worldwide semester class in August or January as long as they have a 2.8 unweighted GPA (waiverable to 2.5). The only class with additional restrictions is ASCI 185 Intro to Flight which is limited to 11/12<sup>th</sup> graders or 10<sup>th</sup> graders by exception and careful consideration by the Aerospace Academy staff.

**Take note parents/students:** Embry-Riddle Aeronautical University Worldwide courses are held in escrow until graduation; their use in a degree-seeking program depends entirely on the degree sought; courses may or may not count as core or electives, depending on the degree program entered in a college other than Embry-Riddle Aeronautical University Worldwide. Email [harric42@erau.edu](mailto:harric42@erau.edu) or see an aviation instructor for more details. All courses meet the practical/fine arts credit requirement for graduation.

### 8600510 Intro to Aerospace and Engineering / Tech Studies I (High school credit – freshmen only)

This course provides students an introduction to the various career fields in aviation/aerospace and engineering. First semester, students will learn about the history of aerodynamics and the development of the airplane through the use of flight simulators and field trips to local aviation museums and military bases. Second semester, students will focus on engineering through hands on experience of tools, history of engineering, industry overview, terminology and an introduction to drafting and computer based design programs.  
*1 year; 1 elective credit; grade 9, no prerequisite.*

#### Fall Semester

### AMNT 240 General Aeronautics and Applications (3 college credits)

This course is an introduction to general aeronautics. It includes the study of physical mathematics, weight and balance, FAA regulations, common and special tools and measuring devices, fluid lines, hardware, aircraft servicing, and documentation (Part 65). This course earns credit towards an FAA Airframe and Powerplant certification.

### ASCI 221 Flight Physiology (3 college credits)

This course explores aero-medical information. Topics include causes, symptoms, prevention, and treatment of flight environment disorders. Altitude effects, spatial disorientation, body heat imbalance, visual anomalies, and psychological factors are included as they relate to pilot performance and survival effectiveness





## CHOICE: Culinary Arts

---

*Culinary courses receive vocational or elective credit*

### 8500355 – Nutrition and Wellness / Food I (one semester)

Keep yourself healthy by learning how to plan and prepare nutritionally balanced meals and snacks. Learn cooking techniques for a variety of different foods and prepare delicious food creations. Instruction and learning activities are provided using hands-on experiences. Grades 9-12

### 8500390 – Principles of Foods/Foods II (one semester)

*Prerequisite(s): "C" average in Nutrition and Wellness; Grades 9-12*

This course builds on skills learned in Foods I. Included in this course will be more complicated principles of food selection and preparation. The students will plan, prepare, and serve creative cuisine from different ethnic groups, regions, and foreign countries.

### 8800510 -- Culinary Arts I

These courses examine food and beverage preparation. They include basic skills in the food service industry as well as the usage of commercial tools and equipment.

1 year, 1 credit / Certifications available in all 4 course levels



## CHOICE: Electricity

---

### 8727210-8727230 - Electricity I-III

*All courses are 1 year, 1 credit, no prerequisite.*



## CHOICE: Welding

---

### 8754510-8754530 - Welding I-III

*All courses are 1 year, 1 credit, no prerequisite.*



## CHOICE: Automotive

---

### 8709410-8709430 – Automotive I-III

*All courses are 1 year, 1 credit, no prerequisite.*



## CHOICE: Engineering

---

The purpose of this program is to provide students with a foundation of knowledge and technically oriented experiences in the study of applications of engineering and its effect upon our lives and the choosing of an occupation. The content and activities will also include the study of entrepreneurship, safety and leadership skills. This program focuses on transferable skills and stresses understanding and demonstration of the technological tools, machines, instruments, materials, processes and systems in business and industry.

### 8600550 – Introduction to Engineering Design

*Prerequisite: strong background in mathematics. 1 credit - Grades: 9-12*

This course teaches problem-solving skills using a design development process. Models of product solutions are created, analyzed and communicated using computer design software.

*This course helps students understand the field of engineering/engineering technology and prepares them for postsecondary engineering programs by developing a more in-depth mastery of the required knowledge and skills in mathematics, science, and technology*



## CHOICE: Information Technology

*Information Technology courses receive fine arts or elective credit.*

### 8207020 – 8207030 –Networking 1 & 2

This course is designed to develop competencies needed for employment in network support positions. The content includes instruction in basic hardware configuration, hardware and software troubleshooting, operating systems, and computer networking. This is one of the highest demand careers for those entering the world of IT. **Not a Fine Art Credit Grades: 9-12**

### 8207310 – Introduction to Information Technology

This course is designed to provide an introduction to information technology concepts and careers. Emphasis is placed on developing proficiency with the fundamental computer applications of keyboarding and word processing so they may be used as communication tools for enhancing personal and workplace proficiency in an information based society. Students will be introduced to the Microsoft Office suite, email and internet services, computing fundamentals, and will have practical experience with Word, Excel, Outlook, and PowerPoint. Curriculum is taught to prepare for national industry certifications of IC3 and MOS certifications in Word, PowerPoint, and Excel. *1 year, 1 credit,; no prerequisite*

### 8209510 - Digital Design 1

This course is designed to develop basic entry-level skills required for careers in the digital publishing industry. The content includes computer skills; digital publishing concepts and operations; layout, design, and measurement activities; decision-making activities; and digital imaging. After successful completion of Digital Design 1 students will have met Occupational Completion Point-B, Production Assistant- SOC Code 43-9031. *1 year 1 credit (Fine Art) 4.0 weight, grades 9-12.*

### 9001110-Foundations of Web Design

This course is designed to teach students the steps in the web development process, how to create and edit graphics for the Web using the Adobe Fireworks software, how to write HTML and CSS code to create a website and how to create a website with the Adobe Dreamweaver software. This course provides students with the opportunity to earn Certified Internet Webmaster certification. *1 year, 1 credit (Fine Art), 4.5 weight, Grades: 9-10*

### 9001120 – User Interface Design

This course is designed to teach students how to create beautiful, user-focused website designs, how to write advanced HTML and CSS code and how to create advanced features of a website using the Adobe Dreamweaver software. This course provides students with the opportunity to earn the Dreamweaver Adobe Certified Associate certification. *1 year, 1 credit (Fine Art), 5.0 weight, prerequisite: Foundations of Web Design / Grades 9-12*



## Diversified Career Technology (DCT)

### 8303010-Diversified Career Tech Principles (DCT 1)

Provides classroom instruction intended to parallel the on-the-job training. *1 year 1 credit; prerequisite DCT Program Director approval.*



## Cosmetology

**Cosmetology (8757210-8905120-8905130)** Utilizing curriculum standards in the salon and spa industry, the program teaches colors, cuts, perms, as well as manicure and facial services and in order to prepare students for the State Board Exam using the milady curriculum.



## FOREIGN LANGUAGES (ELECTIVE CREDIT)

### 0701320 French I

Prerequisite(s):  
"C" average in English  
FCAT Reading Level 3 or higher

As a beginning French student, you will be able to express yourself in basic conversations about yourself, school, your family life, sports and activities, etc. You will be introduced to the French culture and participate in reading writing and listening activities.

### 0701394 Pre-AICE French Language I (French I Honors)\*

Prerequisite(s):  
"B" average in English  
FCAT Reading Level 3 or higher

This is an accelerated French I honors course that gives ½ weighted credit. It is recommended for students with an A or B average in previous English courses and/or previous study of a foreign language.

### 0708340 Spanish I

Prerequisite(s): "C" average in English  
FCAT Reading Level 3 or higher or native speaker

As a beginning Spanish student, you will learn how to engage in conversations in Spanish to express feelings and ideas and exchange opinions; demonstrate understanding of spoken and written Spanish on a variety of topics; present information and ideas to an audience through speaking and writing in Spanish; demonstrate understanding of social interaction patterns within Spanish culture(s) through participation in cultural activities. Imagine going on vacation to a Spanish-speaking country and being able to communicate and enjoy the trip to fullest.

### 0708532 Pre-AICE Spanish Language I (Spanish I Honors)\*

Prerequisites): "B" average in English  
FCAT Reading Level 4 or higher

This is an accelerated course that gives weighted credit. It is recommended for students with an A or B average in previous English courses, and/or previous study of a foreign language and a desire to actively communicate the Spanish language. It is essential for any student who plans to take AP Spanish.

### 0708350 Spanish II

Prerequisite(s):  
"C" average or higher in Spanish I  
Native Spanish speaker

Now that you enjoyed your trip to different Spanish-speaking countries, it is time to take it to a higher level. The purpose of this course is to enable students to enhance proficiency in Spanish through a linguistic, communicative, and cultural approach to language learning.

**Hola!**

**Bonjour!**



## ART (FINE ARTS CREDIT)

### 0101300 - 2-D Art 1

The purpose of this course is to enable students to develop fundamental perceptual, observational, compositional skills necessary to communicate a range of subject matter, symbols, ideas, and concepts using knowledge of two-dimensional art and painting media, processes, and techniques.

*1 year, 1 credit, no prerequisite (9-12)*

### 0102300 - Ceramics / Pottery I

The purpose of this course is to enable students to recognize the properties, possibilities, and limitations of clay by creating functional and nonfunctional works of ceramics and pottery using basic hand-building techniques.

*1 year, 1 credit, no prerequisite (9-12)*

## HEALTH OCCUPATIONS PROGRAM (ELECTIVE CREDIT)

The Health Occupations Program is designed to help students determine if a career in the medical field is suited for them and to determine what direction they should focus. It will also give them basic knowledge to help them be successful in their endeavors. If you like to help people then this program is designed for you.

### 8400320 – Medical Skills and Services

Grades 9-12

This course is designed to provide students with practical generic skills in health occupations which, though applicable to some health occupations, are not designed to prepare students for entry into a specific occupation. Laboratory activities contribute to the development of skills and students will have instruction, demonstration and return demonstration activities in all career clusters studied. This is a practical, hands-on class involving a lot of teamwork and practical skills.

*1 year 1 credit no prerequisite*

## RESERVE OFFICER TRAINING CORPS (ELECTIVE CREDIT)

### ROTC

---

*Junior ROTC courses receive elective credit and .5 of the PE graduation requirement may be met by earning a grade of C or better in any JROTC course and one year of fine art may also be satisfied with 1 year of JROTC. Two years of JROTC will satisfy the one-credit requirement in physical education and the one credit requirement in performing arts. This may not be used for the personal fitness requirement.*

### 1801300-1801330 – Army JROTC I-IV

*1 year 1 credit*

## **PUBLISHING (ELECTIVE CREDIT)**

### **Yearbook (Journalism)**

*Yearbook courses earn elective credit.*

#### **10006300 – Journalism 1 (Newspaper)**

*1 year, 1 elective credit, prerequisite: teacher approval.*

## **MUSIC (PERFORMING ARTS OR ELECTIVE CREDIT)**

*Band and Chorus courses receive performing arts credit*

*Marching band will satisfy one-half credit in physical education or one-half credit in performing arts.*

### **Band**

#### **1302320 – Band III (9<sup>th</sup> grade)**

*1 year, 1 credit, no prerequisite.*

#### **1305320 – Eurhythmics (Color Guard)**

*1 year, 1 credit, prerequisite: Band director's permission (audition only)*

## **MUSIC (PERFORMING ARTS OR ELECTIVE CREDIT)**

### **Chorus**

#### **1303320 – Chorus III (9<sup>th</sup> Grade)**

*1 year, 1 credit, no prerequisite.*

#### **1301360 - Piano Keyboarding**

*1 year, 1 credit, no prerequisite*

## **DRIVER'S EDUCATION (ELECTIVE CREDIT)**

#### **1900310 - Driver's Education Class/Lab**

*1 semester / .5 elective credit*

*Prerequisite: student must be 15 years of age and obtain a restricted operator's license before the end of the 4th week of the semester.*

*Students registered for the course who do not obtain a restricted operators' license or who fail the classroom phase of the course will be placed in an alternate class. Students must pass the classroom phase to go to the driving phase.*

## DRAMA (FINE ARTS OR ELECTIVE CREDIT)

### 0400310-Comp Theater I

*1 year, 1 credit, no prerequisite*

## PHYSICAL EDUCATION (REQUIRED OR ELECTIVE CREDIT)

### 1501300 - Personal Fitness

1 semester credit no prerequisite.

Personal Fitness is **a requirement for the 24 credit diploma**. Students taking this course will (a) learn physical fitness concepts (b) learn about a healthy and physically fit lifestyle; and (c) improve their level of level of fitness.

### 1501340 - Beginning Weight Training

*1 semester, .5 P.E. credit, no prerequisite*

### 1501350 - Intermediate Weight Training

*1 semester, .5 P.E. credit, prerequisite: Beginning Weight Training*

### 1502480 – Outdoor Education

This class offers opportunities to gain experience and education in outdoor activities such as fishing, and involves practical math and communication skills. Outdoor topics will include fresh and salt water fishing, cast netting and boat safety.

*1 semester, .5 P.E. credit, no prerequisite*

### 1503350 – 9<sup>th</sup> Grade PE (1<sup>st</sup> Semester)

*1 semester, .5 P.E. credit, no prerequisite*

### 1501310 – 9<sup>th</sup> Grade PE (2<sup>nd</sup> Semester)

*1 semester, .5 P.E. credit, no prerequisite*

Please use the appropriate course numbers if you will be **PARTICIPATING**  
in one or more of the sports teams listed below.

Students should select to take two semesters of the appropriate sport(s).

<b>Football 1<sup>st</sup> semester:</b> 1501340 Section V (Varsity) 1501340 Section JV (Jr. Varsity) 1501340 Section 9 <sup>th</sup> (9 <sup>th</sup> Grade)	<b>Football 2<sup>nd</sup> semester:</b> 1502410 Section V (Varsity) 1502410 Section JV (Jr. Varsity) 1502410 Section 9 <sup>th</sup> (9 <sup>th</sup> Grade)
<b>Basketball 1<sup>st</sup> semester:</b> 1501340 Section 00Y (Boys) 1501340 Section 00G (Girls)	<b>Basketball 2<sup>nd</sup> semester:</b> 1502410 Section 00Y (Boys) 1502410 Section 00G (Girls)
<b>Soccer 1<sup>st</sup> semester:</b> 1501340 Section 00M (Boys and Girls)	<b>Soccer 2<sup>nd</sup> semester:</b> 1502410 Section 00M (Boys and Girls)
<b>Cross Country 1<sup>st</sup> semester:</b> 2200300 Section 0CC (Boys and Girls)	<b>Track 2<sup>nd</sup> semester:</b> 2200300 Section 00T (Boys and Girls)
<b>Baseball 1<sup>st</sup> semester:</b> 1501390 Section 00E	<b>Baseball 2<sup>nd</sup> semester:</b> 1501410 Section 00E
<b>Softball 1<sup>st</sup> semester:</b> 1501340 Section 0SB	<b>Softball 2<sup>nd</sup> semester:</b> 1502410 Section 0SB

## ESE

### 7963080 – Learning Strategies

*1 year; 1 elective credit; grades 9-11; Prerequisite: ESE program eligibility*

The purpose of this course is to provide instruction that enables students with disabilities to acquire and use strategies and skills to enhance their independence as learners in educational and community settings

## CHOICE HIGH SCHOOL and TECHNICAL CENTER

Okaloosa County High School students may concurrently attend Choice High School and Technical Center. Students who attend will earn elective credits needed for graduation, and possibly National Industry Certification as well as Bright Futures Gold Seal Scholarship. Students interested in Career and Technical courses and certifications should contact their guidance counselors or Choice High School and Technical Center @ 833-3500. Courses and course numbers are as follows:

**AMAT-Administrative Medical Assistant Technology (8212201)** Using an instructional lab set up as an actual medical office, the program offers practical instruction in the performance of office procedures specific to the medical environment such as medical transcription, front desk communication skills, medical terminology and medical insurance coding.

**Automotive Technology (8709410)** Utilizing a classroom and hands on approach, the program focuses on automotive diagnostic systems and repair services which can lead to ASE certifications (Automotive Service Excellence).

**Certified Nursing Assistant (8417100)** The program offers a foundation of knowledge and skills, expanding the traditional role of nursing assistant for both acute and long term care settings. (The program is offered in the evening as a dual enrollment course).

**Certified Veterinary Assistant (8111510)** Utilizing a simulated animal hospital, this course of study blends four essential elements into a program that leads to certification as a veterinary assistant, kennel technician and/or pet groomer through Animal Care Technologies (ACT).

**Construction Technology (8720310)** The program focuses on construction processes; such as framing, roofing, siding, interior millwork and cabinetry; as well as, estimation, scheduling, blueprint reading and technical and production skills needed to prepare students for employment or advanced training in the building construction industry.

**Cosmetology (8757210)** Utilizing curriculum standards in the salon and spa industry, the program teaches colors, cuts, perms, as well as manicure and facial services in order to prepare students for the State Board Exam.

**Creative/Digital Arts (8718010)** Utilizing cutting edge technology, the program offers practical experiences in computer generated art and text, graphic design, photography, animation, simulation and illustration; and the development of specialized skill in multimedia presentations.

**Culinary Arts (8800510)** The course content will include food preparation and serving; and identification, storage, selection and presentation of a wide variety of foods. Students can earn a National Restaurant ProStart Certification developed by the National Restaurant Association and earn college credit through Johnson & Wales University.

**Digital Cinema (8772110)** The program develops knowledge in storytelling, planning, shooting, editing and finalizing video content for DVD and Web. Students will use real world footage to demonstrate the features of Final Cut Pro and develop practical techniques used in film and video productions. Completers can receive an Apple Final Cut Certification.

**Horticulture/Landscaping (8121510)** The program is designed to provide practical experience in landscape design and landscape and turf maintenance and is great for those who like to be outdoors.

**Welding Technology (8754510)** Using classroom and hands on experiences, the program features MIG, TIG and stick welding for aluminum and steel fabrication. This high skilled/high wage job is very much in demand in the southeast.

## Grade Level Checklist

### *What should I do my freshman year?*

1. Begin preparation for mastering initial reading and math skills tested on FCAT.
2. Make sure your course selections are preparing you for your future goals.
3. Consider taking Pre-AP/Honors/AP courses in your areas of strength.
4. Take schoolwork seriously because 9<sup>th</sup> grade counts toward college admission and the Bright Futures Scholarship.
5. Take computer & technology courses early in high school to develop essential skills.
6. Use a day planner to develop your organization and time management skills.
7. Develop good attendance habits.
8. Join service organizations at Crestview High School and in the community that may expose you to new interests and possible careers.
9. Make contacts with people who are involved in careers that interest you.
10. Access [www.facts.org](http://www.facts.org) on-line and become familiar with the resources available there.
11. Research admission requirements for several different colleges and universities.

### *What should I do my sophomore year?*

1. **Continue working on mastering initial reading and math skills tested on FCAT.**
2. Review your course selections and be sure they are preparing you for your future goals. Take the most rigorous course of study you can. Check the requirements for the Bright Futures Scholarship.
3. Be an active participant in clubs and consider leadership roles.
4. Continue working on volunteer hours in community service.
5. Visit the college and career resource room in the media center. Pay close attention to courses required for admission to schools you are interested in attending.
6. Visit [www.collegeboard.com](http://www.collegeboard.com) and [www.facts.org](http://www.facts.org) on-line and become familiar with the resources available there.
7. Take the PSAT test.
8. Begin to prepare a student resume with community service hours, academic, & athletic achievements.
9. Meet with college representatives when they visit our campus.
10. Maintain and improve your GPA.

### *What should I do in the FALL of my junior year?*

1. Take courses you need to meet your goals. Research the course work required by the school you wish to attend. Check the requirements for the Bright Futures Scholarship.
2. Take as many AP courses as you can and be successful. AP courses give you the opportunity to earn college credit while still in high school and colleges tend to look favorably upon those students who take a rigorous course of study.
3. Maintain and improve your GPA. Grades can make the difference in whether or not you receive scholarships and grants.
4. Register to take the ACT & SAT tests in the spring.
5. Request literature and applications from colleges and universities.
6. Attend the college/university fair held at the community college.
7. Check the media center for ACT and SAT test prep materials and scholarship information.
8. Visit [www.collegeboard.com](http://www.collegeboard.com) and [www.facts.org](http://www.facts.org) on-line and become familiar with the resources.
9. Register to take the ASVAB test. This test provides you with a free career evaluation as well as practice in standardized testing. You will also be provided with information regarding job placement if you enter the military.

### *What should I do in the SPRING of my junior year?*

1. Take the ACT and SAT exams.
2. Write a resume. Start to develop portfolios, audition tapes or writing samples if they are required for admission or scholarships.
3. Think about people who might write you a letter of recommendation; start with teachers, counselors and employers.
4. Discuss your family's financial resources and review plans for financial aid.
5. Schedule visits to college campuses. Make appointments, especially if visiting during the summer.
6. Check the scholarship box in the media center regularly.
7. Student athletes should register with the NCAA clearinghouse; see your guidance counselor for information.
8. For summer, consider enrolling in summer school programs, completing an internship or working as a volunteer.

## *What should I do in the FALL of my senior year?*

1. Review your course selections to be sure they will prepare you for your future goals. Check the requirements for the Bright Futures Scholarship. Continue to challenge yourself by taking AP courses.
2. **Do not let “senioritis” set in. Colleges want to see strong academics in your senior year, and many universities (FSU, UF, etc) can and will revoke acceptance letters to students if their projected 8<sup>th</sup> semester classes are dropped!**
3. Continue to evaluate colleges and narrow your choices.
4. Visit [www.collegeboard.com](http://www.collegeboard.com) and [www.FACTS.org](http://www.FACTS.org) online and become familiar with the resources available.
5. Locate people willing to write a letter of recommendation for you. Start with teachers, counselors and employers. You should request the recommendation letters at least a month in advance of any deadlines.
6. Prepare and submit application packages. Review deadlines and requirements, such as test scores, transcripts, essays, and recommendations. Give teachers, counselors, employers or other adults at least a month to complete the recommendation forms and provide a stamped self-addressed envelope with each letter.
7. Fill out the required paperwork in the guidance office to release your transcript information.
8. Keep track of early decision deadlines at colleges with which you have an interest.
9. Attend college fair held at the community college.
10. Schedule to meet with college representatives when they visit Crestview.
11. Take the SAT & ACT test or re-take if needed.
12. Gather information required to fill out the Free Application for Federal Student Aid (FAFSA) application.

## *What should I do in the SPRING of my senior year?*

1. After January 1, but before the earliest college deadline, file the FAFSA. Complete the application online and early to maximize your chances for receiving financial aid ([www.fafsa.ed.gov](http://www.fafsa.ed.gov)).
2. Register for the Bright Futures Scholarship online.
3. Request transcripts to be sent again to all colleges to which you are applying.
4. Monitor applications to make sure all materials are sent on time.
5. Wait for college admissions decisions and financial aid award letters. You need to determine the school that best meets your academic and financial needs. Many schools have an early May deadline to accept or decline offers of admission. Some may require a deposit to reserve a space in the freshman class.
6. Apply for housing if you plan to live on campus. Watch deadlines and remember to send thank you notes to all who assisted you in the application process



