

# 2017 Product Catalog



# bartolini®

## PICKUPS & ELECTRONICS

BC45	BC45C	BC4C	BC42
BC55	BC5C	BC52	
BD45	BD4C	BD42	
BD55	BD5C	BD52	
P245	P24C	P242	
P255	P25C	P252	
P265	P26C	P262	
P455	P45C	P452	
P465	P46C	P462	
M345	M34C	M342	
M445	M44C	M442	
M455	M45C	M452	
M465	M46C	M462	
M545	M54C	M542	
M555	M55C	M552	
M565	M56C	M562	
M645	M64C	M642	
M655	M65C	M652	
M665	M66C	M662	
H545	H54C	H542	
H555	H55C	H552	
H565	H56C	H562	
CF45	CF4C	CF42	
CF55	CF5C	CF52	

**Jazz Guitar**

**Original Series**

**7 & 8 String**

**Vintage Brand**

**Classic Bass**

**Original**

**Original Split**

**Bass Candybars**

**Classic Bass**

**Original**

Bartolini is a registered trademark of Bartolini, Inc.  
 Bartolini® Basses are registered trademarks of Bartolini Musical Instruments Corp. Bartolini is not affiliated with Fender.  
 Music Man is a registered trademark of Music Man, Inc. Bartolini is not affiliated with Music Man.  
 Plectro-Edwards is a registered trademark of Plectro-Edwards International Corporation. Bartolini is not affiliated with Plectro-Edwards.  
 Seymour Duncan is a trademark of Seymour Duncan Corp. Bartolini is not affiliated with Seymour Duncan.  
 Sustainiac is a registered trademark of Sustainiac (USA), LTD. Bartolini is not affiliated with Sustainiac.

**Bartolini Pickups and Electronics** is recognized around the world as the standard in Pro-Level guitar and bass guitar tone with the broadest selection to fit almost any instrument and sound. Our comprehensive product line of pickups and electronics can be mixed and matched to express the individuality of any player.

## NEW PRODUCTS FOR 2017

**ACE Hum-Killer Singles:** Our popular ACE Single Coil Strat upgrade pickups are now available as Hum-Killer stacked coil pickups. Taking guitars to a higher level of tonal versatility ACE Hum-Killer Singles combine Alnico V and Ceramic magnets, aggressive field shaping, and a tuned hum-killing resonant coil. They marry the warm vintage voice of Alnico with the power, clarity, and stability of Ceramic magnets. ACE Hum-Killer Singles are designed in a blade configuration with a narrow sensing aperture for maximum clarity and response even with extreme bends. Like all Professional-Level Bartolini pickups, they are sweat-proof, fully shielded against electronic noise, and microphonic-free. The Ace Hum-Killers have individual voices for Neck, Middle and Bridge positions (ACE-SV-60, 65 & 75). Available in clean-top white or black.

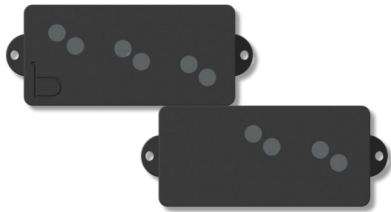

**b-axis Series P Bass Pickups:** Get huge, punchy tone with precise articulation and full harmonic clarity. With exposed Alnico V pole pieces in a tuned magnetic structure, the b-axis series provides a complex, asymmetric response like the natural voice of the finest instruments. Available in 4 and 5 string fully encapsulated, hum-cancelling models.

**2J Squared Bass Soapbars:** They are 2 J Bass Pickups in a soapbar shape. While we started making these decades ago, we are releasing them in all of our Bass Soapbar shapes. Ideal for the most flexible bass, they can be split to individual Dual Inline Coil Jazz pickups to be fully hum-killing even on the noisiest stage or studio. With all coils enabled, the tone is truly enormous with huge lows and extended range for intense articulation.

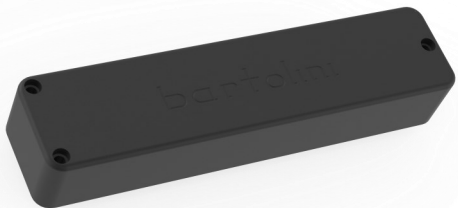
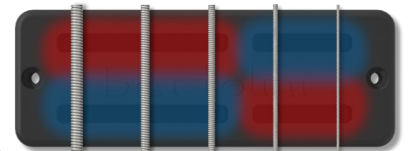

**BH1 & MK2 Upgrade Pickups:** Our new H6 Soapbar shape is a drop in upgrade for the Ibanez BH1 and MK2 pickups. They will be ready to ship this spring in Classic Bass, Original Dual Coil, SINGULARITY, and 2J Squared configurations for 5 and 6 string instruments.

## The Bartolini Product Line:

**Guitar Pickups-** Humbuckers, Strat®, P-90, Jazz, and Acoustic

**ACE™ Series Guitar Pickups:** Alnico V and Ceramic magnets combined for high output vintage tone

**Bass Pickups-** J-Bass®, P-Bass®, Music Man®, Bass Soapbars, Bass Candybars, Rickenbacker®

**b-axis Series Bass Pickups:** Pro-Level Exposed Alnico V Pickups for J-Bass® and P-Bass®

**SINGULARITY™ Series Bass Soapbars:** Single coil soapbars for 4, 5, and 6 string basses

**Pre-wired Harnesses:** Over 52 configuration varying by volume, tone controls, and active/passive options.

**Electronics Modules:** Pre-Amps, 2-Band & 3-Band Equalizers, & Buffers

**Active & Passive:** All of our pickups are passive, and can be combined with any of our pre-wired pre-amp harnesses for active output. Our “AP” harnesses offer push-pull volume control to select either active or true-bypass passive output. All our wiring diagrams are available online at [www.bartolini.net](http://www.bartolini.net).

**New Pickups Graphics:** Get an inside look at the structures that make the voices. Our new graphics help understand how the coils are configured, how the magnetic fields are projected, and how the strings align with those structures. These artistic renderings also show the drill pattern and relative size

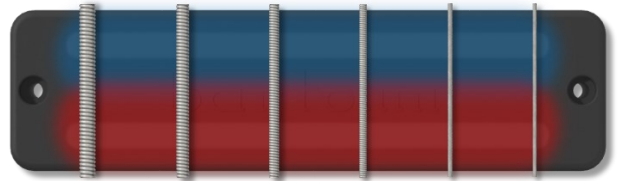

for each pickup. North magnetic field is shown as red while South magnetic field is shown as blue. Purple is used for some single coils to show choice.

## Builder & Retail Sales Contact Information

### U.S. Builder Sales & Support

#### Bartolini Inc. Main Office

Hours: 9 AM to 5 PM PST (M-F)

Phone: (805) 543-1330

Email: [sales@bartolini.net](mailto:sales@bartolini.net)

Support: [support@bartolini.net](mailto:support@bartolini.net)

### U.S. Dealer Sales & Support

#### Dana B. Goods

Phone: (800) 741-0109

Sales Inquiries: [Sales@danabgoods.com](mailto:sales@danabgoods.com)

Support Inquiries: [Support@danabgoods.com](mailto:support@danabgoods.com)

## GUITAR PICKUPS

**ACE™ Series Pickups:** The expanded tonal range and rich harmonics of our ACE pickups are created by combining alnico (the “A” in ACE) and ceramic (the “CE” in ACE) magnets for the best of both worlds, producing the hot tone you want from an alnico pickup, balanced with the clarity you expect from ceramic. Their Hot Vintage tone is great for Rock, Progressive, Funk, and Heavy Blues. The new Hum-Killer feature an isolated and shielded coil for the same voice as the True Single coil version but hum-free.

Humbuckers come in black, nickel, gold, and chrome. The singles come in black and white. Ringless versions are black.

Style	Model	Description
Humbucker	<b>ACE-H-70</b>	Neck Humbucker
	<b>ACE-H-75</b>	Bridge Humbucker
True Single	<b>ACE-S-60N</b>	Neck (north) Single
	<b>ACE-S-65S</b>	Middle (south) Single
	<b>ACE-S-75N</b>	Bridge (north) Single
Hum-Killer Single	<b>ACE-SV-60</b>	Neck Hum-Killer Single
	<b>ACE-SV-65</b>	Middle Hum-Killer Single
	<b>ACE-SV-75</b>	Bridge Hum-Killer Single
Ringless	<b>ACE-M36-70</b>	Neck humbucker in M3 shape
	<b>ACE-M36-75</b>	Bridge humbucker in M3 shape

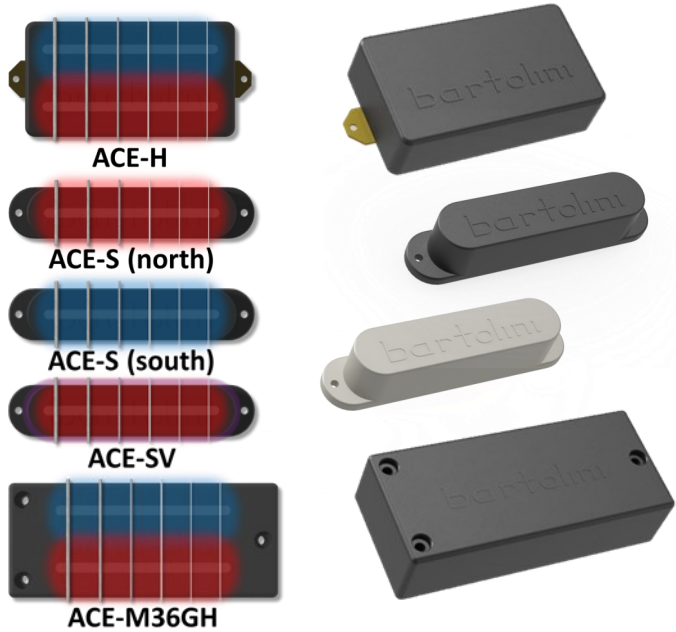

**PBF Humbuckers:** Our PBF humbuckers come in three different varieties to get you the right tone for your style. The "vintage" pair (PBF 49/51) feature sweet high end and classic warm tones, with focused and defined lows. The "jazz" set (PBF 55/57) brings out a more rounded, softer tone that excels at smoothing out the high register of many guitars. The "rock" set (PBF55/77D) are high-output models that make sure clarity and smoothness aren't lost, even at high volume levels. Available in black, nickel, gold, and chrome.

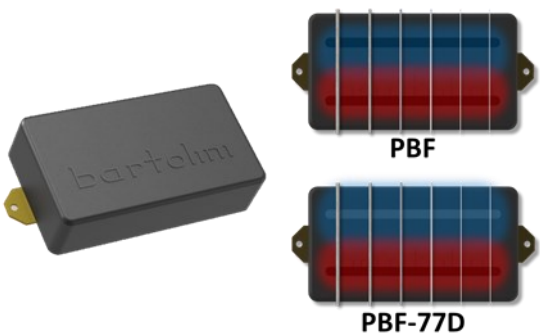

Style	Model	Description
Vintage Pair	<b>PBF-49</b>	vintage neck humbucker -solid body guitar
	<b>PBF-51</b>	vintage bridge humbucker -solid body guitar
Rock pair	<b>PBF-55</b>	rock neck humbucker
	<b>PBF-77D</b>	high output, great for distortion humbucker
Jazz pair	<b>PBF-55</b>	jazz Guitar (hollow body) neck humbucker
	<b>PBF-57</b>	jazz Guitar (hollow body) bridge humbucker

## GUITAR PICKUPS

**7 & 8 String Extended Guitar Humbuckers:** Our extended range guitar pickups are perfect for a Heavy Metal Machine. Combined bass and guitar pickups, they provide crushing lows and screaming highs. The dual blade design ensures high output even with multi-step bends. Killer tone with or without an onboard preamp.

Style	Model	Description
7 String M3 Shape	M37GH-30	Broad Spectrum Neck Humbucker
	M37GH-35	Broad Spectrum Bridge or Heavy Neck
	M37GH-40	Heavy Neck Humbucker
8 String M4 Shape	M48GH-30	Broad Spectrum Neck Humbucker
	M48GH-35	Broad Spectrum Bridge or Heavy Neck
	M48GH-40	Heavy Neck Humbucker

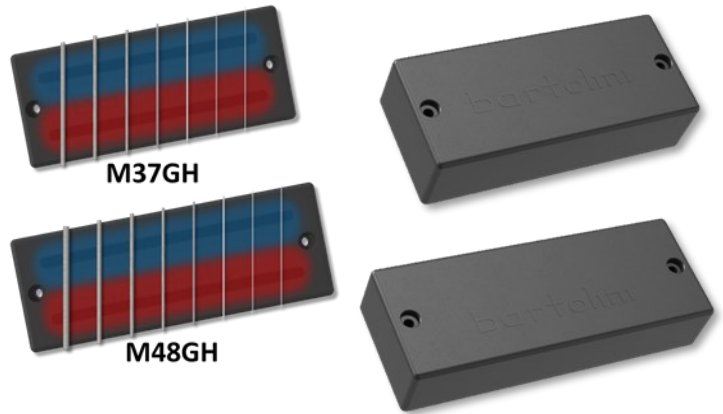

**Original Humbuckers:** Our original humbuckers are well known for their high clarity and definition.

Model	Description
1C	Our first humbucker, the 1C has unequal windings for a clear, clean tone single coil voice with less mid warmth than equal winding designs - Neck or bridge positions.
1CTA	Designed for Tuck Andres, the 1CTA has very near the 1C tone but equal windings for best noise rejection, but biased sensing - Neck position
V92C-B	Warm, clear tone - Neck or bridge position
1D-01	More lows and low mids than V92C-B - Bridge position

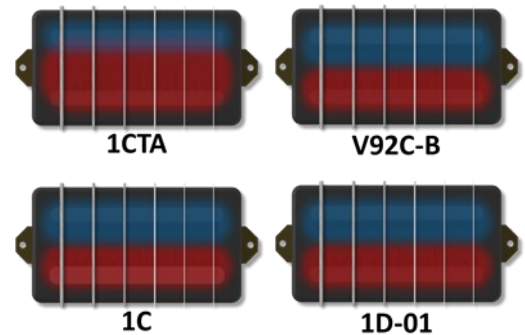

**Original Single Coils:** Designed to get the most of the Strat sound at each position. Each is available in N or S polarity. Black or White

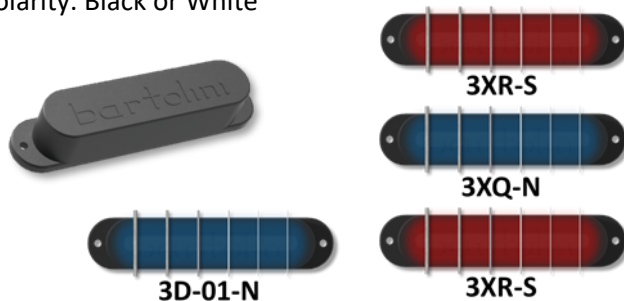

Model	Description
3X	Neck: clear, smooth, jazzy full range single coil
3XQ	Middle: very clear, smooth, near Vintage tone single coil
3XR	Bridge: deeper tone, high power, single coil
3D-01	Bridge: bright and deep with excellent mids, single coil



## GUITAR PICKUPS

**Soapbar (P90 Shape):** Our "Original" guitar soapbars bring a glassy clarity and articulate dynamics to your instrument, configured into the classic Gibson P90 pickup shape.

Model	Description
<b>SB92C-B</b>	warm, clear tone - like V92C-B - in Soapbar shell -
<b>SB-D01</b>	more lows and low mids than V92C-B - in Soapbar shell - for bridge

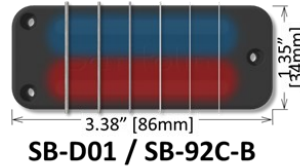

**Jazz Guitar (Johnny Smith type):** Johnny Smith worked closely with Gibson to design full-bodied arch-top guitars, and we pay homage to that classic Jazz guitar sound with our own jazz pickup. The dual coil Johnny Smith (JS) humbucker gets a smooth, clear distinctive tone available with or without adjustable brackets for mounting to the end of your fretboard. The pickup body is less than 7/16" thick.

Model	Description
<b>5J</b>	smooth, clear dual coil - end of fingerboard 2—2-1/4" adjustable bracket
<b>5JNB</b>	smooth, clear dual coil - without mounting bracket

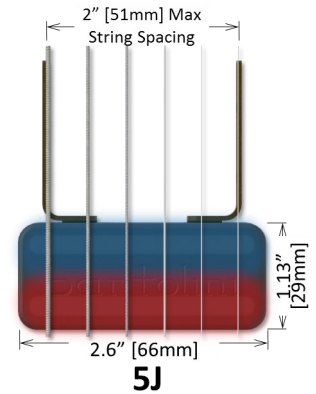

**Acoustic Guitar:** Our sound-hole mounted pickups are bright and clear with B-string compensation and a 10 foot cable. The brackets fits most holes 3 7/8" or bigger.

Model	Description
<b>3AV</b>	sound hole mount - bright, clear hum-canceller (stacked coil) - B-string compensation, plastic mounting brackets and 10 foot cable with strain relief.



## BASS PICKUPS

**J-Bass® Pickups:** Bartolini Jazz Bass pickups are highly respected by both bass players and master luthiers because of their outstanding tone, innovative design, and build quality. All 3 families are available to fit Fender Standard 4-string, Standard 5-String, and American Standard 5-String pickup routes. All models feature fully encapsulated coils to protect against the rigors of professional bass players - sweat, microphonic noise, and feedback. All Bartolini Jazz Bass pickups are passive designs that can be used with passive controls or with an onboard preamp for an active instrument.



### b-axis:

They feature a new and unique fully encapsulated Alnico V exposed pole piece design. b-axis Jazz bass pickups are a dual-inline hum-cancelling design for use in professional venues. Musicians who play jazz, rock, country, gospel, and hip-hop are already finding their voice in b-axis pickups.



### Classic Bass:

The Classic Bass series pickups have enhanced treble response and narrower apertures for more incisive attack and focused sound without harshness. They are available as Dual Inline Hum-Killing (CBJD) or True Single Coil (CBJS) designs. They are also available with 2 different voicings - Deep voice or Bright voice. The Classic Bass series is popular with progressive, jazz, gospel, and metal musicians.



### Original:

This family offers deep, throaty tone with strong lows and low mids. They feature a dual in-line hum-cancelling (J) or single coil (S) designs. This Original series is popular with rock, blues, and hip-hop musicians.

## J-Bass® Pickup Sizes

When Fender designed the J Bass, they made the pickups different sizes for neck and bridge positions. The neck is narrower because the strings are closer together at the neck pickup position. Fender 5 string pickups are also different size for their Standard V and their American Standard V (and Deluxe V). Be sure to pick the right size to fit your bass.

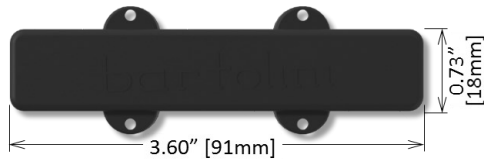

**Standard 4 or 5 String Neck**



**American Standard 5 Neck**



**Standard 4 or 5 String Bridge  
or Long Neck**







**American Standard 5 Bridge  
or Long Neck**

**BASS PICKUPS**

**b-axis**

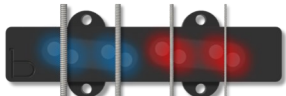
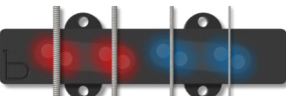
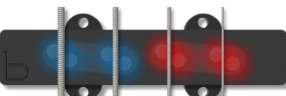
The new Bartolini b-axis pickups series is based on the very foundations of Bill Bartolini's initial pickup designs back in the early '70s. The guiding design principle was to provide a highly asymmetric magnetic field in order to fully capture string vibration. This "high asymmetry" (hence the pickup's original "High A" name) provides tone similar to acoustic instruments, which have a naturally asymmetric response due to bridge structure and variations in biased tension. While most of our pickups are built around this principle, our b-axis feature exposed pole pieces, which serve to emphasize string attack. What does all this mean for you as a player? Huge, gutsy tone with our biggest mids yet, paired with the full low-end that Bartolini's bass pickups are renowned for.

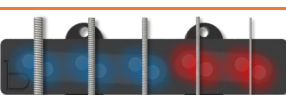
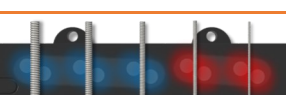

19mm Bridge Model	Description
 <b>J44J-S</b>	b-axis Jazz Split Coil Alnico 4 String Neck - 53.2mm string center to center
 <b>J44J-L</b>	b-axis Jazz Split Coil Alnico 4 String Bridge - 56.5mm string center to center
 <b>J44J-LN</b>	b-axis Jazz Split Coil Alnico 4 String Long Neck - 53.2mm string center to center
 <b>J45J-S-19</b>	b-axis Jazz Split Coil Alnico 5 String Standard 19mm Neck - 69.7mm string center to center
 <b>J45J-L-19</b>	b-axis Jazz Split Coil Alnico 5 String Standard 19mm Bridge - 74.1mm string center to center
 <b>J45J-LN-19</b>	b-axis Jazz Split Coil Alnico 5 String Standard 19mm Long Neck - 69.7mm string center to center
 <b>J55J-S-19</b>	b-axis Jazz Split Coil Alnico 5 String American Standard 19mm Neck - 69.7mm string center to center
 <b>J55J-L-19</b>	b-axis Jazz Split Coil Alnico 5 String American Standard 19mm Bridge - 74.1mm string center to center

18mm Bridge Model	Description
 <b>J45J-S-18</b>	b-axis Jazz Split Coil Alnico 5 String Standard 18mm Neck - 66.7mm string center to center
 <b>J45J-L-18</b>	b-axis Jazz Split Coil Alnico 5 String Standard 18mm Bridge - 70.4mm string center to center
 <b>J45J-LN-18</b>	b-axis Jazz Split Coil Alnico 5 String Standard 18mm Long Neck - 66.7mm center to center
 <b>J55J-S-18</b>	b-axis Jazz Split Coil Alnico 5 String American Standard 18mm Neck - 66.7mm center
 <b>J55J-L-18</b>	b-axis Jazz Split Coil Alnico 5 String American Standard 18mm Bridge - 70.4mm center-



## BASS PICKUPS

### Classic Bass Series J-Bass® Pickups:

Bold, up-front clarity that adds a new dimension to your tonal palette. Compared to our Original series, the Classic Bass series pickups have enhanced treble response and narrower apertures for more incisive attack and focused sound without harshness. This added dimension of treble definition vastly increases the tonal range available in active or passive instruments. Their output levels are slightly higher than similar models in the Original series. They are available as dual in-line hum-canceling (CBJD) or single coil (CBJS) designs. They are also available with 2 different voicings - Deep voice or Bright voice. The Classic Bass series is popular with progressive, jazz, gospel, and metal musicians.











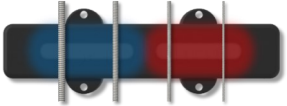
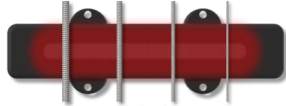
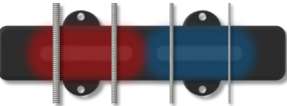
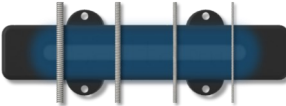
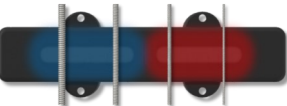
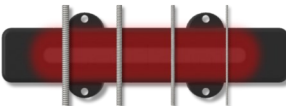

Model	Description	Model	Description
 <b>9CBJD-S1</b>	J-Bass, 4-String, Strong Lows Low Mids, Classic Bass, Dual In-Line Coil, Neck Position—48-64mm [9CBJD-S3—Bright version]	 <b>9CBJS-S1</b>	J-Bass, 4-String, Strong Lows Low Mids, Classic Bass, Single Coil, Neck Position—60mm Max [9CBJS-S3—Bright version]
 <b>9CBJD-L1</b>	J-Bass, 4-String, Strong Lows Low Mids, Classic Bass, Dual In-Line Coil, Bridge Position—48-64mm [9CBJD-L3—Bright version]	 <b>9CBJS-L1</b>	J-Bass, 4-String, Strong Lows Low Mids, Classic Bass, Single Coil, Bridge Position—60mm Max [9CBJS-L3—Bright version]
 <b>9CBJD-LN1</b>	J-Bass, 4-String, Strong Lows Low Mids, Classic Bass, Dual In-Line Coil, Long Neck—48-64mm [9CBJD-LN3—Bright version]	 <b>9CBJS-LN1</b>	J-Bass, 4-String, Strong Lows Low Mids, Classic Bass, Single Coil, Long Neck—60mm Max [9CBJS-LN3—Bright version]
 <b>59CBJD-S1</b>	J-Bass, 5-String, Strong Lows Low Mids, Classic Bass, Dual In-Line Coil, Neck Position—59-72mm [59CBJD-S3—Bright version]	 <b>59CBJS-S1</b>	J-Bass, 5-String, Strong Lows Low Mids, Classic Bass, Single Coil, Neck Position—72mm Max [59CBJS-S3—Bright version]
 <b>59CBJD-L1</b>	J-Bass, 5-String, Strong Lows Low Mids, Classic Bass, Dual In-Line Coil, Bridge Position—60-75mm [59CBJD-L3—Bright version]	 <b>59CBJS-L1</b>	J-Bass, 5-String, Strong Lows Low Mids, Classic Bass, Single Coil, Bridge Position—75mm Max [59CBJS-L3—Bright version]
 <b>59CBJD-LN1</b>	J-Bass, 5-String, Strong Lows Low Mids, Classic Bass, Dual In-Line Coil, Long Neck—59-72mm [59CBJD-LN3—Bright version]	 <b>59CBJS-LN1</b>	J-Bass, 5-String, Strong Lows Low Mids, Classic Bass, Single Coil, Long Neck—72mm Max [59CBJS-LN3—Bright version]
 <b>57CBJD-S1</b>	J-Bass, 5-String, American Std., Classic Bass, Dual-In-line Coil, Neck Position—59-78mm [57CBJD-S3—Bright version]	 <b>67CBJD-S1</b>	J-Bass, 6-String, American Std., Classic Bass, Dual-In-line Coil, Neck Position—65-83mm [67CBJD-S3—Bright version]
 <b>57CBJD-L1</b>	J-Bass, 5-String, American Std., Classic Bass, Dual-In-line Coil, Bridge Position—60-81mm [57CBJD-L3—Bright version]	 <b>67CBJD-L1</b>	J-Bass, 6-String, American Std., Classic Bass, Dual-In-line Coil, Bridge Position—65-83mm [67CBJD-L3—Bright version]

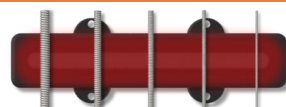
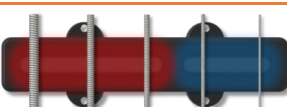
## BASS PICKUPS

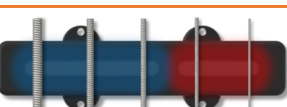
### Original Series J-Bass® Pickups:



The original Bartolini design gives you the timeless tone that started it all – big, full lows and low mids, with our matchless hum-canceling clarity. Available in dual (J) or single (S) coil designs, you'll find all the depth of tone you need right here. However, if you are looking for bottomless bass, they're also available in our deep voicing (ST) incarnation. Original Barts bring out your voice, low and clear.

Model	Description	Model	Description
 <b>9J-S1</b>	J-Bass, 4-String, Strong Lows Low Mids, Original, Dual In-Line Coil, Neck Position—48-64mm [9J1-L/S Set]	 <b>9S-S</b>	J-Bass, 4-String, Original, Single Coil, Neck Position—60mm Max [9ST-S—Deep version]
 <b>9J-L1</b>	J-Bass, 4-String, Strong Lows Low Mids, Original, Dual In-Line Coil, Bridge Position—48-64mm	 <b>9S-L</b>	J-Bass, 4-String, Original, Single Coil, Bridge Position—60mm Max [9ST-L—Deep version]
 <b>9J-LN1</b>	J-Bass, 4-String, Strong Lows Low Mids, Original, Dual In-Line Coil, Long Neck Position—48-64mm [9J1-L/LN Set]	 <b>9S-LN</b>	J-Bass, 4-String, Original, Single Coil, Neck Position—60mm Max [9ST-LN—Deep version]
 <b>59J-S1</b>	J-Bass, 5-String, Strong Lows Low Mids, Original, Dual In-Line Coil, Neck Position—59-72mm [59J1-L/S Set]	 <b>59JS-S1</b>	J-Bass, 5-String, Deep Tone, Original, Single Coil, Neck—72mm Max [59S72-S—Deep version]
 <b>59J-L1</b>	J-Bass, 5-String, Strong Lows Low Mids, Original, Dual In-Line Coil, Bridge Position—60-75mm	 <b>59JS-L1</b>	J-Bass, 5-String, Deep Tone, Original, Single Coil, Bridge—75mm Max [59S72-L—Deep version]
 <b>59J-LN1</b>	J-Bass, 5-String, Strong Lows Low Mids, Original, Dual In-Line Coil, Long Neck Position—59-72mm [59J1-L/LN Set]	 <b>59JS-LN1</b>	J-Bass, 5-String, Deep Tone, Original, Single Coil, Long Neck—72mm Max [59S72-LN—Deep version]
 <b>57J-S1</b>	J-Bass, 5-String, American Std., Deep Tone Strong Lows, Original, Dual In-Line Coil, Neck Position—59-78mm [57J1-L/LN Set]	 <b>69J-S1</b>	J-Bass, 6-String, Strong Lows Low Mids, Original, Dual In-Line Coil, Neck Position—62-72mm [69J1-L/S Set]
 <b>57J-L1</b>	J-Bass, 5-String, American Std., Deep Tone Strong Lows, Original, Dual In-Line Coil, Bridge Position—60-81mm	 <b>69J-L1</b>	J-Bass, 6-String, Strong Lows Low Mids, Original, Dual In-Line Coil, Bridge Position—65-75mm [69J1-LN—Long Neck]

## BASS PICKUPS



### P-Bass® Pickups:

Bartolini P-Bass Pickups bring out the deepest, fattest lows for your bass, for tone that's warm, full and balanced.

**b-axis:** Our NEW b-axis P Bass Pickups are all about enormous, clear tone. Like their J Bass sisters, these pickups have loads of low-end, along with resonant high-mids for incredible articulation and harmonic response. The coil arrangement pulls more bass from the low strings and more highs from the treble strings. b-axis Pro-Level Split Coil Hum-Killing pickups are fully sealed and shielded to meet the demands of touring, studio, and session players.

Model	Description
<p><b>PB4</b></p>	<p>b-axis P-Bass Split Coil Alnico 4 String - 53mm string center to center</p> <p>[Pairs with J44J-L]</p>

Model	Description
<p><b>PB5</b></p>	<p>b-axis P-Bass Split Coil Alnico 5 String - 70mm string center to center</p> <p>[Pairs with J45J-L-19]</p>

**Classic Bass:** These P Bass pickups have enhanced treble response and narrower apertures for more incisive attack and focused sound without harshness. They retain the warmer fuller, low end of P-Bass pickups but still provide an appreciably increased tonal range in active or passive instruments, with higher output than our "Original" series.

Model	Description
<p><b>8CBP</b></p>	<p>P-Bass, 4-String, Classic Bass, Thick Tone, Split Coil Pair—40-60mm</p> <p>[Pairs with 9CBJD-L1]</p>

Model	Description
<p><b>58CBP</b></p>	<p>P-Bass, 5-String, Classic Bass, Thick Tone, Split Coil Pair—52-72mm</p> <p>[Pairs with 59CBJD-L1]</p>

**Original:** P-bass Original series pickups are your best choice for the biggest, fattest bottom end. No other pickup can deliver the warm, open lows the way these do. Ensuring that any unwanted "woof" is eliminated, the split coil blade keeps your sound tight and clear, all while deliver huge bass response. You'll never find lower tones produced with higher fidelity!

Model	Description
<p><b>8S</b></p>	<p>P-Bass, 4-String, Original Series, Deep Voice, Split Coil Pair—40-60mm</p> <p>[Pairs with 9J-L1 or 9S-L]</p> <p>[8SU Bright Version]</p>

Model	Description
<p><b>58S72</b></p>	<p>P-Bass, 5-String, Original Series, Deep Voice, Split Coil Pair—52-72mm</p> <p>[Pairs with 59J-L1 or 59JS-L]</p> <p>[58SU72 Bright Version]</p>

**BASS PICKUPS**

**Music Man® Pickups:**

With boundless, meaty lows and glassy, brilliant highs, our Music Man pickups provide next-level tone and clarity, with the help of our dual-coil and quad-coil hum-canceling craftsmanship.

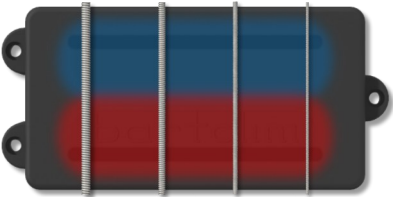
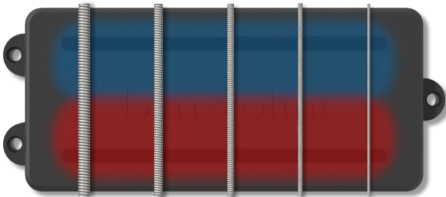
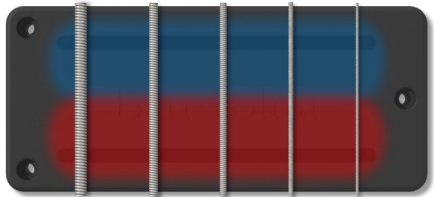

**Classic Bass:** Our Music Man Classic Bass series pickups feature enhanced treble response and narrower apertures for more incisive attack and focused sound without harshness. They have a dramatically increased tonal range in active or passive instruments, with higher output than our Original series. Popular among progressive, jazz, gospel, and metal players, our Classic J-Bass series

 <p><b>MM4CBC</b></p>	 <p><b>DL5CBC</b></p>	 <p><b>MV5CBC</b></p>
4-String—60mm max string spacing	5-String—76mm max string spacing	5-String—75mm max string spacing

**Original:** Our Music Man "Original" series pickups bring you the timeless tone that started it all – big, full lows and low mids. You'll find all the depth of tone you need right here, along with our matchless hum-canceling clarity. Original Barts upgrade pickups bring out your voice, low and clear.

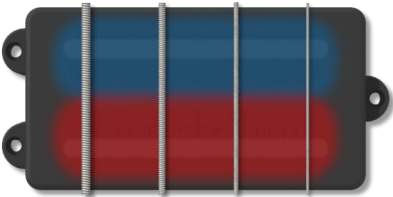
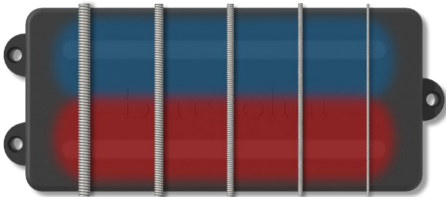
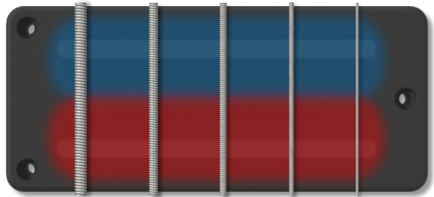
 <p><b>MMC</b></p>	 <p><b>76DL5C</b></p>	 <p><b>74MV5C</b></p>
4-String—60mm max string spacing	5-String—76mm max string spacing	5-String—75mm max string spacing

**2J Squared:** We took two of our Jazz Bass pickups and combined them into one shell, creating this quad-coil monster. This split-ready configuration gives you complete freedom to define your own version of the pickup's huge jazz tone. The 2J's extended tonal range allows for more "air" and definition at the top end, without sacrificing any of the lows and low mids you need for monster growl. Just add a switch to your bass and you can flip to J mode.

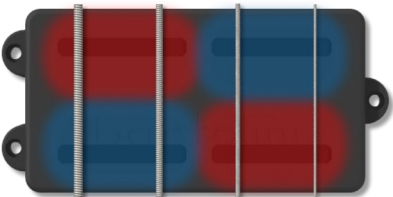
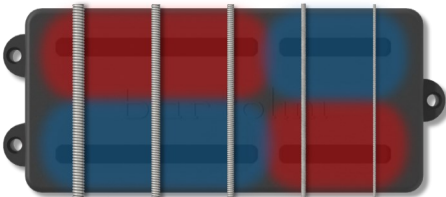
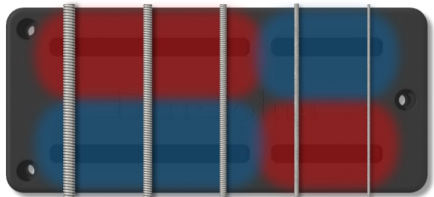
 <p><b>MM42CBJD3</b></p>	 <p><b>DL52CBJD3</b></p>	 <p><b>MV52CBJD3</b></p>
4-String—48-64mm string spacing	5-String—64-80mm string spacing	5-String—64-80mm string spacing



**BASS PICKUPS**

**Bass Soapbars:** The Soapbar pickup shape is among the most universal in bass guitars, and we have a variety of shapes to ensure that whatever bass you're playing, you can make it sound massive and clear with Bartolini tone!

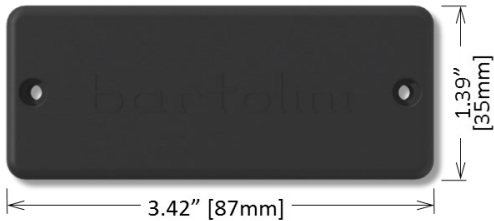

**BB**

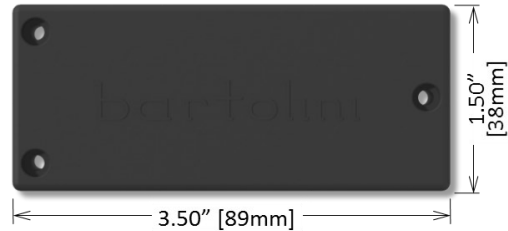

**M3**



**BC**

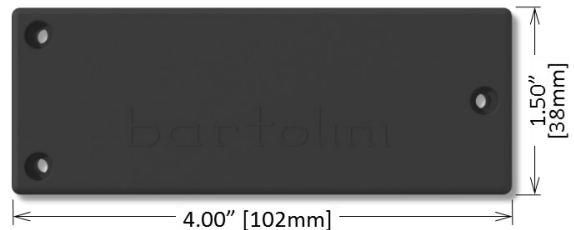

**M4**



**BD**

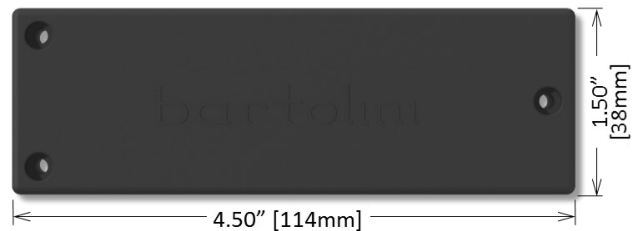

**M5**



**P2**



**CF**



**P4**



**H6**



**MK**



## BASS PICKUPS

**2J Squared:** Like our Quad Coil Music Man Dual Jazz pickups, these soapbars feature 2 Jazz pickups in a box. Ideal for the most flexible bass, they can be split to individual Dual Inline Coil Jazz pickups to be fully hum-killing even on the noisiest stage or studio. With all coils enabled, the tone is truly enormous with huge lows and extended range for intense articulation. Like all of our Pro-Level Pickups, they are available in matched pairs for neck (Bass, -B) and bridge (Treble, -T).

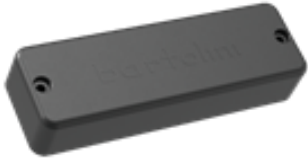



Model	Description	Model	Description
 BB42J	4-String, BB Soapbar, 2J Squared Quad Coil—60mm BB42J-B neck, BB42J-T bridge	 M342J	4-String, M3 Soapbar, 2J Squared Quad Coil—60mm M342J-B neck, M342J-T bridge
 BC42J	4-String, BC Soapbar, 2J Squared Quad Coil—60mm BC42J-B neck, BC42J-T bridge	 M442J	4-String, M4 Soapbar, 2J Squared Quad Coil—60mm M442J-B neck, M442J-T bridge
 BC52J	5-String, BC Soapbar, 2J Squared Quad Coil—71mm BC52J-B neck, BC52J-T bridge	 M452J	5-String, M4 Soapbar, 2J Squared Quad Coil—76mm M452J-B neck, M452J-T bridge
 BD42J	4-String, BD Soapbar, 2J Squared Quad Coil—60mm BD42J-B neck, BD42J-T bridge	 M462J	6-String, M4 Soapbar, 2J Squared Quad Coil—80mm M462J-B neck, M462J-T bridge
 BD52J	5-String, BD Soapbar, 2J Squared Quad Coil—71mm BD52J-B neck, BD52J-T bridge	 M552J	5-String, M5 Soapbar, 2J Squared Quad Coil—76mm M552J-B neck, M552J-T bridge
 P242J	4-String, P2 Soapbar, 2J Squared Quad Coil—60mm P242J-B neck, P242J-T bridge	 M562J	6-String, M5 Soapbar, 2J Squared Quad Coil—84mm M562J-B neck, M562J-T bridge
 P252J	5-String, P2 Soapbar, 2J Squared Quad Coil—76mm P252J-B neck, P252J-T bridge	 MK42J	4-String, MK Soapbar, 2J Squared Quad Coil—60mm MK42J-B neck, MK42J-T bridge
 P262J	6-String, P2 Soapbar, 2J Squared Quad Coil—84mm P262J-B neck, P262J-T bridge	 MK52J	5-String, MK Soapbar, 2J Squared Quad Coil—71mm MK52J-B neck, MK52J-T bridge
 P452J	5-String, P4 Soapbar, 2J Squared Quad Coil—76mm P452J-B neck, P452J-T bridge	 MK62J	6-String, MK Soapbar, 2J Squared Quad Coil—84mm MK62J-B neck, MK62J-T bridge
 P462J	6-String, P4 Soapbar, 2J Squared Quad Coil—90mm P462J-B neck, P462J-T bridge	 CF42J	4-String, CF Soapbar, 2J Squared Quad Coil—60mm CF42J-B neck, CF42J-T bridge
 H652J	5-String, H6 Soapbar, 2J Squared Quad Coil—76mm H652J-B neck, H652J-T bridge	 CF52J	5-String, CF Soapbar, 2J Squared Quad Coil—76mm CF52J-B neck, CF52J-T bridge
 H662J	6-String, H6 Soapbar, 2J Squared Quad Coil—90mm H662J-B neck, H662J-T bridge		

**BASS PICKUPS**

**SINGULARITY:** For a massive Jazz bass voice in your soapbar bass, these true single coil pickups deliver. The Singularity's asymmetric blade design provides brighter tones in the high frequency range and lots of large, warm low end. Like all of our Pro-Level Pickups, they are sweat-proof and rugged, and they are shielded from coil-to-cavity to tame a noisy stage or studio. Available in matched pairs for neck (Bass, -B, North) and bridge (Treble, -T, South).

















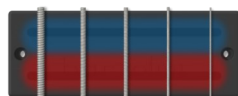



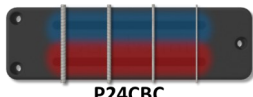

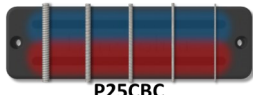
Model	Description
 BB4S	4-String, BB Soapbar, Singularity Single Coil—60mm BB4S-B neck, BB4S-T bridge
 BC4S	4-String, BC Soapbar, Singularity Single Coil—60mm BC4S-B neck, BC4S-T bridge
 BC5S	5-String, BC Soapbar, Singularity Single Coil—72mm BC5S-B neck, BC5S-T bridge
 BD4S	4-String, BD Soapbar, Singularity Single Coil—60mm BD4S-B neck, BD4S-T bridge
 BD5S	5-String, BD Soapbar, Singularity Single Coil—72mm BD5S-B neck, BD5S-T bridge
 P24S	4-String, P2 Soapbar, Singularity Single Coil—60mm P24S-B neck, P24S-T bridge
 P25S	5-String, P2 Soapbar, Singularity Single Coil—76mm P25S-B neck, P25S-T bridge
 P26S	6-String, P2 Soapbar, Singularity Single Coil—84mm P26S-B neck, P26S-T bridge
 P45S	5-String, P4 Soapbar, Singularity Single Coil—76mm P45S-B neck, P45S-T bridge
 P46S	6-String, P4 Soapbar, Singularity Single Coil—90mm P46S-B neck, P46S-T bridge
 H65S	5-String, H6 Soapbar, Singularity Single Coil—76mm H65S-B neck, H65S-T bridge
 H66S	6-String, H6 Soapbar, Singularity Single Coil—90mm H66S-B neck, H66S-T bridge

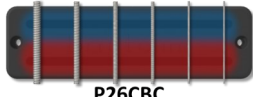
Model	Description
 M34S	4-String, M3 Soapbar, Singularity Single Coil—60mm M34S-B neck, M34S-T bridge
 M44S	4-String, M4 Soapbar, Singularity Single Coil—60mm M44S-B neck, M44S-T bridge
 M45S	5-String, M4 Soapbar, Singularity Single Coil—72mm M45S-B neck, M45S-T bridge
 M46S	6-String, M4 Soapbar, Singularity Single Coil—84mm M46S-B neck, M46S-T bridge
 M55S	5-String, M5 Soapbar, Singularity Single Coil—72mm M55S-B neck, M55S-T bridge
 M56S	6-String, M5 Soapbar, Singularity Single Coil—84mm M56S-B neck, M56S-T bridge
 MK4S	4-String, MK Soapbar, Singularity Single Coil—60mm MK4S-B neck, MK4S-T bridge
 MK5S	5-String, MK Soapbar, Singularity Single Coil—76mm MK5S-B neck, MK5S-T bridge
 MK6S	6-String, MK Soapbar, Singularity Single Coil—84mm MK6S-B neck, MK6S-T bridge
 CF4S	4-String, CF Soapbar, Singularity Single Coil—60mm CF4S-B neck, CF4S-T bridge
 CF5S	5-String, CF Soapbar, Singularity Single Coil—76mm CF5S-B neck, CF5S-T bridge

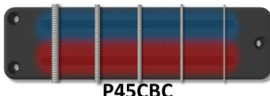
**BASS PICKUPS**



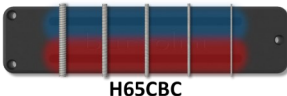



















**Classic Bass:** Our Classic Bass pickups with enhanced treble response and higher output than our Original bass pickups and offer bold, up-front clarity that adds new dimensions to your tone. The Classic Bass series is popular with progressive, jazz, gospel, and metal musicians where articulation is critical. For deep bass, rich and clear high-end, look no further. Without sacrificing low-end, Classic Bass pickups let you turn up the tone. Available in matched pairs for neck (Bass, -B) and bridge (Treble, -T).

Model	Description	Model	Description
 BB4CBC	4-String, BB Soapbar, Classic Bass, Dual Coil—60mm BB4CBC-B neck, BB4CBC-T bridge	 M34CBC	4-String, M3 Soapbar, Classic Bass, Dual Coil—60mm M34CBC-B neck, M34CBC-T bridge
 BC4CBC	4-String, BC Soapbar, Classic Bass, Dual Coil—60mm BC4CBC-B neck, BC4CBC-T bridge	 M44CBC	4-String, M4 Soapbar, Classic Bass, Dual Coil—60mm M44CBC-B neck, M44CBC-T bridge
 BC5CBC	5-String, BC Soapbar, Classic Bass, Dual Coil—71mm BC5CBC-B neck, BC5CBC-T bridge	 M45CBC	5-String, M4 Soapbar, Classic Bass, Dual Coil—76mm M45CBC-B neck, M45CBC-T bridge
 BD4CBC	4-String, BD Soapbar, Classic Bass, Dual Coil—60mm BD4CBC-B neck, BD4CBC-T bridge	 M46CBC	6-String, M4 Soapbar, Classic Bass, Dual Coil—80mm M46CBC-B neck, M46CBC-T bridge
 BD5CBC	5-String, BD Soapbar, Classic Bass, Dual Coil—71mm BD5CBC-B neck, BD5CBC-T bridge	 M55CBC	5-String, M5 Soapbar, Classic Bass, Dual Coil—76mm M55CBC-B neck, M55CBC-T bridge
 P24CBC	4-String, P2 Soapbar, Classic Bass, Dual Coil—60mm P24CBC-B neck, P24CBC-T bridge	 M56CBC	6-String, M5 Soapbar, Classic Bass, Dual Coil—84mm M56CBC-B neck, M56CBC-T bridge
 P25CBC	5-String, P2 Soapbar, Classic Bass, Dual Coil—76mm P25CBC-B neck, P25CBC-T bridge	 MK4CBC	4-String, MK Soapbar, Classic Bass, Dual Coil—60mm MK4CBC-B neck, MK4CBC-T bridge
 P26CBC	6-String, P2 Soapbar, Classic Bass, Dual Coil—84mm P26CBC-B neck, P26CBC-T bridge	 MK5CBC	5-String, MK Soapbar, Classic Bass, Dual Coil—71mm MK5CBC-B neck, MK5CBC-T bridge
 P45CBC	5-String, P4 Soapbar, Classic Bass, Dual Coil—76mm P45CBC-B neck, P45CBC-T bridge	 84MK6CBC	6-String, MK Soapbar, Classic Bass, Dual Coil—84mm MK6CBC-B neck, MK6CBC-T bridge
 90P46CBC	6-String, P4 Soapbar, Classic Bass, Dual Coil—90mm P46CBC-B neck, P46CBC-T bridge	 CF4CBC	4-String, CF Soapbar, Classic Bass, Dual Coil—60mm CF4CBC-B neck, CF4CBC-T bridge
 H65CBC	5-String, H6 Soapbar, Classic Bass, Dual Coil—76mm H65CBC-B neck, H65CBC-T bridge	 CF5CBC	5-String, CF Soapbar, Classic Bass, Dual Coil—76mm CF5CBC-B neck, CF5CBC-T bridge
 H66CBC	6-String, H6 Soapbar, Classic Bass, Dual Coil—90mm H66CBC-B neck, H66CBC-T bridge		



## BASS PICKUPS

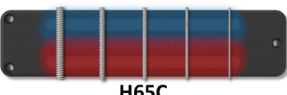







**Original Series:** The Original Bartolini sound is all about bass! No other pickup can deliver the gigantic, luxuriant lows of Original Barts. But not only to they provide for bottomless lows and low-mids, their dual coil construction eliminates the noise and "boomy" quality that vast amounts of low-end can create. The originals are full and warm for that vintage tone you've been craving, without the "woofy" quality that can drown out the voice of the instrument. You'll never find lower tones produced with higher clarity! Available in matched pairs for neck (Bass, -B) and bridge (Treble, -T).

Model	Description	Model	Description
 BB4C	4-String, BB Soapbar, Original, Dual Coil—60mm BB4C-B neck, BB4C-T bridge	 M34C	4-String, M3 Soapbar, Original, Dual Coil—60mm M34C-B neck, M34C-T bridge
 BC4C	4-String, BC Soapbar, Original, Dual Coil—60mm BC4C-B neck, BC4C-T bridge	 M44C	4-String, M4 Soapbar, Original, Dual Coil—60mm M44C-B neck, M44C-T bridge
 BC5C	5-String, BC Soapbar, Original, Dual Coil—71mm BC5C-B neck, BC5C-T bridge	 72M45C	5-String, M4 Soapbar, Original, Dual Coil—72mm 72M45C-B neck, 72M45C-T bridge
 BD4C	4-String, BD Soapbar, Original, Dual Coil—60mm BD4C-B neck, BD4C-T bridge	 M46C	6-String, M4 Soapbar, Original, Dual Coil—80mm M46C-B neck, M46C-T bridge
 BD5C	5-String, BD Soapbar, Original, Dual Coil—71mm BD5C-B neck, BD5C-T bridge	 72M55C	5-String, M5 Soapbar, Original, Dual Coil—72mm 72M55C-B neck, 72M55C-T bridge
 P24C	4-String, P2 Soapbar, Original, Dual Coil—60mm P24C-B neck, P24C-T bridge	 M56C	6-String, M5 Soapbar, Original, Dual Coil—84mm M56C-B neck, M56C-T bridge
 74P25C	5-String, P2 Soapbar, Original, Dual Coil—74mm 74P25C-B neck, 74P25C-T bridge	 MK4C	4-String, MK Soapbar, Original, Dual Coil—60mm MK4C-B neck, MK4C-T bridge
 P26C	6-String, P2 Soapbar, Original, Dual Coil—84mm P26C-B neck, P26C-T bridge	 MK5C	5-String, MK Soapbar, Original, Dual Coil—71mm MK5C-B neck, MK5C-T bridge
 P45C	5-String, P4 Soapbar, Original, Dual Coil—76mm P45C-B neck, P45C-T bridge	 MK6C	6-String, MK Soapbar, Original, Dual Coil—84mm MK6C-B neck, MK6C-T bridge
 P46C	6-String, P4 Soapbar, Original, Dual Coil—90mm P46C-B neck, P46C-T bridge	 CF4C	4-String, CF Soapbar, Original, Dual Coil—60mm CF4C-B neck, CF4C-T bridge
 H65C	5-String, H6 Soapbar, Original, Dual Coil—76mm H65C-B neck, H65C-T bridge	 CF5C	5-String, CF Soapbar, Original, Dual Coil—76mm CF5C-B neck, CF5C-T bridge
 H66C	6-String, H6 Soapbar, Original, Dual Coil—90mm H66C-B neck, H66C-T bridge		





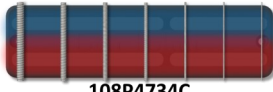

## BASS PICKUPS

**Original Quad:** Voiced very similar to our Original Dual Coil bass pickups, our Quad-coil design provides extended reach and a wider sensing area, allowing for a narrower pickup to work with wider-spaced strings. Preserving the full-bodied low end of our Original series and adding even more articulation, our Original Quads are able to split coils to either a P-bass or reverse P-bass configuration for even more voicing options. Available in matched pairs for neck (Bass, -B) and bridge (Treble, -T).



Model	Description	Model	Description
 XXP25C	5-String, P2 Soapbar, Original Quad Coil—80mm XXP25C-B neck, XXP25C-T bridge	 XXM45C	5-String, M4 Soapbar, Original Quad Coil—80mm XXM45C-B neck, XXM45C-T bridge
 XXP26C	6-String, P2 Soapbar, Original Quad Coil—90mm XXP26C-B neck, XXP26C-T bridge	 XXM46C	6-String, M4 Soapbar, Original Quad Coil—90mm XXM46C-B neck, XXM46C-T bridge
 XXP46C	6-String, P4 Soapbar, Original Quad Coil—95mm XXP46C-B neck, XXP46C-T bridge	 XXM55C	5-String, M5 Soapbar, Original Quad Coil—80mm XXM55C-B neck, XXM55C-T bridge
 108P4734C	7-String, P4 Soapbar, Original Split Coil—108mm 108P4734-B neck, 108P4734-T bridge	 XXM56C	6-String, M5 Soapbar, Original Quad Coil—95mm XXM56C-B neck, XXM56C-T bridge

**Original Split:** Voiced very similar to our Original Dual Coil bass pickups, our Split-coil design provides extended reach and a wider sensing area, allowing for a narrower pickup to work with wider-spaced strings. Original Split pickups preserve the full-bodied low end of our Original series and adding even more articulation, a simple setup, and high value. Available in matched pairs for neck (Bass, -B) and bridge (Treble, -T).

Model	Description	Model	Description
 XXP25M	5-String, P2 Soapbar, Original Split Coil—80mm XXP25M-B neck, XXP25M-T bridge	 XXM45M	5-String, M4 Soapbar, Original Split Coil—80mm XXM45M-B neck, XXM45M-T bridge
 XXP26M	6-String, P2 Soapbar, Original Split Coil—90mm XXP26M-B neck, XXP26M-T bridge	 XXM46M	6-String, M4 Soapbar, Original Split Coil—90mm XXM46M-B neck, XXM46M-T bridge
 XXP46M	6-String, P4 Soapbar, Original Split Coil—95mm XXP46M-B neck, XXP46M-T bridge	 XXM55M	5-String, M5 Soapbar, Original Split Coil—80mm XXM55M-B neck, XXM55M-T bridge
		 XXM56M	6-String, M5 Soapbar, Original Split Coil—95mm XXM56M-B neck, XXM56M-T bridge



## BASS PICKUPS

### Bass Candybars:

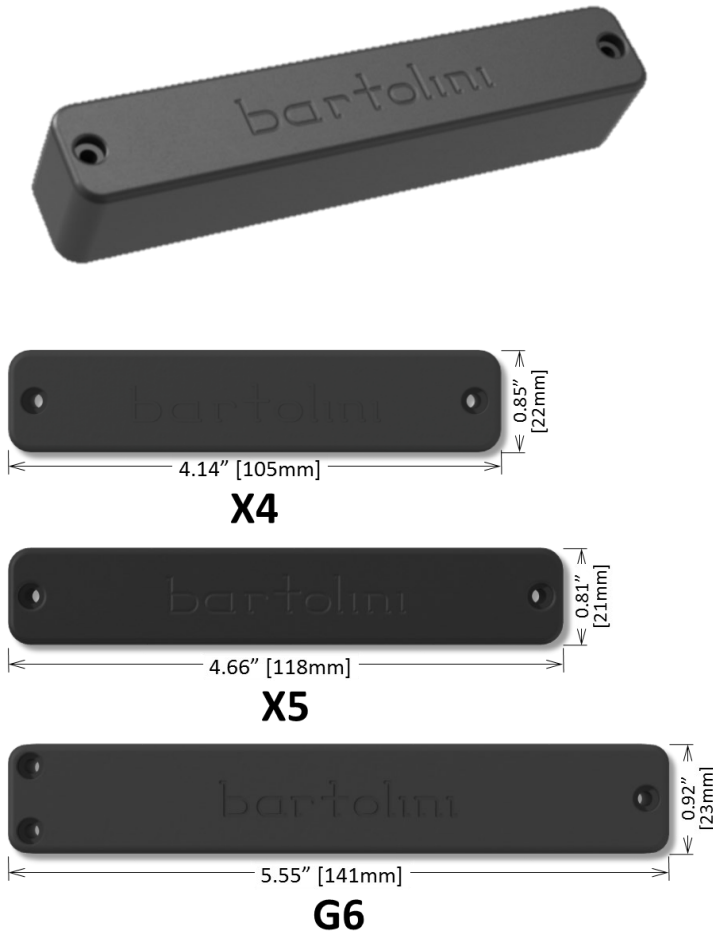

Bass Candybars are like Jazz Bass pickups but with no mounting ears. These narrow soapbars are perfect for very sweet, clean Jazz style bass installations.





### Original Candybars:

The original Bartolini design gives you the timeless tone that started it all – big, full lows and low mids, with our matchless hum-canceling clarity. Available in Dual In-Line Hum-Killer designs, you'll find all the depth of tone you need right here. Original Barts bring out your voice, low and clear.

Model	Description
 <b>X44J1-B</b>	4-String, X4 Candybar, Original, Dual In-Line Coil, Neck Position—48-64mm
 <b>X44J1-T</b>	4-String, X4 Candybar, Original, Dual In-Line Coil, Bridge Position—48-64mm
 <b>X45J1-B</b>	5-String, X4 Candybar, Original, Dual In-Line Coil, Neck Position—60-76mm
 <b>X45J1-T</b>	5-String, X4 Candybar, Original, Dual In-Line Coil, Bridge Position—60-76mm
 <b>X55J1-B</b>	5-String, X5 Candybar, Original, Dual In-Line Coil, Neck Position—60-84mm
 <b>X55J1-T</b>	5-String, X5 Candybar, Original, Dual In-Line Coil, Bridge Position—60-84mm

Model	Description
 <b>100G66J1-B</b>	6-String, G6 Candybar, Original, Dual In-Line Coil, Neck —65-100mm
 <b>100G66J1-T</b>	4-String, X4 Candybar, Original, Dual In-Line Coil, Bridge —48-64mm

Model	Description
 <b>108G67J1-B</b>	7-String, G6 Candybar, Original, Dual In-Line Coil, Neck —72-108mm
 <b>108G67J1-T</b>	7-String, G6 Candybar, Original, Dual In-Line Coil, Bridge —72-108mm

## BASS PICKUPS



### Classic Bass Candybars:



Classic Bass series pickups have enhanced treble response and narrower apertures for more incisive attack and focused sound without harshness. The Classic Bass series allows for a vastly increased tonal range in active or passive instruments, with higher output than our Original series. The Classic series is available in Dual In-Line Hum-Killer or True single coil configurations with two different voicings, Deep or Bright. Popular among progressive, jazz, gospel, and metal players, our Classic J-Bass series offers the perfect marriage of warm, deep bottom end and glassy, articulate highs.



Model	Description
 <b>X44CBJD-B1</b>	4-String, X4 Candybar, Classic Bass, Dual In-Line Coil, Neck Position—48-64mm
 <b>X44CBJD-T1</b>	4-String, X4 Candybar, Classic Bass, Dual In-Line Coil, Bridge Position—48-64mm
 <b>X45CBJD-B1</b>	5-String, X4 Candybar, Classic Bass, Dual In-Line Coil, Neck Position—60-76mm
 <b>X45CBJD-T1</b>	5-String, X4 Candybar, Classic Bass, Dual In-Line Coil, Bridge Position—60-76mm
 <b>X55CBJD-B1</b>	5-String, X5 Candybar, Classic Bass, Dual In-Line Coil, Neck Position—60-84mm
 <b>X55CBJD-T1</b>	5-String, X5 Candybar, Classic Bass, Dual In-Line Coil, Bridge Position—60-84mm

Model	Description
 <b>X44CBJS-B1</b>	4-String, X4 Candybar, Classic Bass, Single Coil, Neck Position—60mm
 <b>X44CBJS-T1</b>	4-String, X4 Candybar, Classic Bass, Single Coil, Bridge Position—60mm
 <b>X45CBJS-B1</b>	5-String, X4 Candybar, Classic Bass, Single Coil, Neck Position—75mm
 <b>X45CBJS-T1</b>	5-String, X4 Candybar, Classic Bass, Single Coil, Bridge Position—75mm
 <b>X55CBJS-B1</b>	5-String, X5 Candybar, Classic Bass, Single Coil, Neck Position—76mm
 <b>X55CBJS-T1</b>	5-String, X5 Candybar, Classic Bass, Single Coil, Bridge Position—76mm

Model	Description
 <b>G66CBJD-B1</b>	6-String, G6 Candybar, Classic Bass, Dual In-Line Coil, Neck —65-100mm
 <b>G66CBJD-T1</b>	4-String, X4 Candybar, Classic Bass, Dual In-Line Coil, Bridge —48-64mm

Model	Description
 <b>G68JD-B1</b>	8-String, G6 Candybar, Classic Bass, Dual In-Line Coil, Neck —84-120mm
 <b>G68JD-T1</b>	8-String, G6 Candybar, Classic Bass, Dual In-Line Coil, Bridge —84-120mm

**BASS PICKUPS**

**Vintage Brand:**

Bartolini makes drop-in replacement upgrades for many iconic bass brands to really bring them to life!

**Rickenbacker:** Available in split and dual coil configurations, our Rickenbacker bass pickups allow you to keep the legendary "Rickenbacker tone," but without the clank and noise of the Rick's abrasive high end. Bartolini pickups bring out a lower, more well-rounded tone out of the instrument with more clarity and definition.

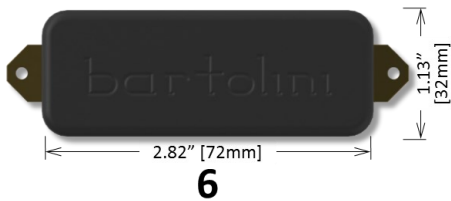

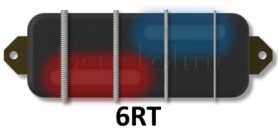
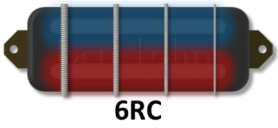
Model	Description
 <b>6RT</b>	Rickenbacker, 4-String, Original, Split Coil, Neck Position —51mm max string spacing
 <b>6RC</b>	Rickenbacker, 4-String, Original, Dual Coil, Bridge Position —51mm max string spacing



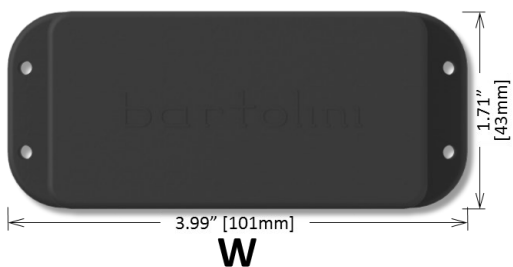
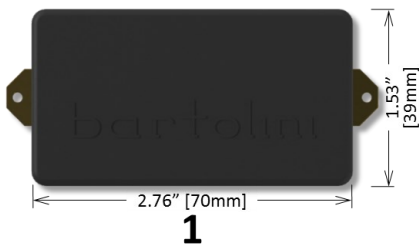

**Gibson & Washburn:** Our upgrades are available in Classic Bass and Original voices.



 <b>1CBC</b>	 <b>1CB</b>
Bass Humbucker, Gibson Size with bracket, 4-String, Classic Bass 1CBC-T Bridge, 1CBC-B Neck	Bass Humbucker, Gibson Size with bracket, 4-String, Original 1CB-T Bridge, 1CB-B Neck
 <b>T4CBC</b>	 <b>T4C</b>
Bass Humbucker, Thunderbird Size, 4-String, Classic Bass T4CBC-T Bridge, T4CBC-B Neck	Bass Humbucker, Thunderbird Size, 4-String, Original T4CB-T Bridge, T4CB-B Neck
 <b>W4CBC</b>	 <b>W4C</b>
Bass Humbucker, Washburn Size, 4-String, Classic Bass W4CBC-T Bridge, W4CBC-B Neck	Bass Humbucker, Washburn Size, 4-String, Original W4CB-T Bridge, W4CB-B Neck

ELECTRONICS

**Pre-Wired Harnesses:** Pre-Wired harness saves the time and aggravation of wiring your pre-amp and pots into your instrument. They feature our industry leading pre-amps and premium audio-quality potentiometers with smooth control and ready for years of rugged use. There are 26 configurations to choose from varying by volume controls, tone controls, and active/passive options.

Product	Description	EQ
<u>HR-2.2AP/918</u> 	Volume (with Active/Passive push-pull switch)- Treble/ Bass stack	2-band
<u>HR-2.3AP/918</u> 	Volume (with Active/Passive push-pull switch) – Treble - Bass	2-band
<u>HR-2.4AP/918</u> 	Volume (with Active/Passive push-pull switch) - Treble/ Bass Stack - Mid (with Hi/Lo push-pull switch)	3-band
<u>HR-2.5AP/918</u> 	Volume (with Active/Passive push-pull switch) - Treble - Bass - Mid (with Hi/Lo push-pull switch)	3-band
<u>HR-3.3/918</u> 	Volume - Blend - Treble/Bass stack	2-band
<u>HR-3.3AP/918</u> 	Like HR-3.3 with Active/Passive push-pull switch on Volume knob	2-band
<u>HR-3.4/918</u> 	Volume/Volume stack - Mid (p-p) - Treble/Bass stack	3-band
<u>HR-4.2AP/918</u> 	Volume - Volume - Treble - Bass with Active/Passive push-pull switch on Volume knob	2-band
<u>HR-4.5/918</u> 	Volume - Blend - Treble - Bass	2-band
<u>HR-4.5AP/918</u> 	Like HR-4.5 with Active/Passive push-pull switch on Volume knob	2-band
<u>HR-4.6/918</u> 	Volume - Blend – Mid (with Hi/Lo push-pull switch) - Treble/Bass stack	3-band
<u>HR-4.6AP/918</u> 	Like HR-4.6 with Active/Passive push-pull switch on Volume knob	3-band
<u>HR-4.7/918</u> 	Volume - Blend - Mid (w. switch) - Treble/Bass stack	3-band
<u>HR-4.7AP/918</u> 	Like HR-4.7 with Active/Passive push-pull switch on Volume knob	3-band
<u>HR-5.2/918</u> 	Volume - Blend - Treble – Mid (with Hi/Lo push-pull switch) - Bass	3-band
<u>HR-5.2AP/918</u> 	Like HR-5.2 with Active/Passive push-pull switch on Volume knob	3-band
<u>HR-5.3AP/918</u> 	Volume-Volume-Treble-Mid (w.switch) – Bass with Active/Passive push-pull switch on 2nd. Volume knob	3-band
<u>HR-5.4/918</u> 	Volume-Blend-Treble-Mid (w.switch) - Bass	3-band
<u>HR-5.4AP/918</u> 	Like HR-5.4 with Active/Passive push-pull switch on Volume knob	3-band

**ELECTRONICS**



**HR-5.4AP/918 Harness Contents**

**Pre-Wired Harness Benefits:**

- ⇒ Isolates the pickup output so that outboard effects and amps do not weaken the pickup's output
- ⇒ Offers numerous EQ options and allows both cut and boost to each EQ control
- ⇒ Wired for either 9V or 18V operation, and the jack provides on/off to the battery to maximize battery life

**Modules:** We offer buffers and pre-amps that are preferred by the world's best luthiers. They are very low noise, and the pre-amps produce a full spectrum tonality with 2-band and 3-band EQ to deliver your exact tonal preferences.

Note: We offer potentiometer kits that match our modules to successfully wire your instrument.

Product	Description
<b>AGB/918-2</b>	Adjustable gain buffer/pre-amp with 0 to ~12dB gain, 9v or 18volt operation
<b>AGDB/918-2</b>	Adjustable gain dual-channel buffer/pre-amp with 0 to ~12dB gain, 9v or 18volt operation
<b>NTMB+ F</b>	3-band tone control preamp with fully independent bass, midrange, and treble
<b>NTBTG/918</b>	2-band tone control preamp with fully independent bass and treble
<b>TCT</b>	Tone control module with very wide range of boost and cut of the bass and treble spectrum and midrange cut at 300Hz. 9V operation
<b>XTCT</b>	Tone control module with very wide range of boost and cut of the bass and treble spectrum and midrange cut at 500Hz. 9V operation
<b>MPB2Kit/918</b>	Magnetic and Piezo buffer/pre-amp with 25K blend pot and adjustable gain trim pot for the magnetic channel.

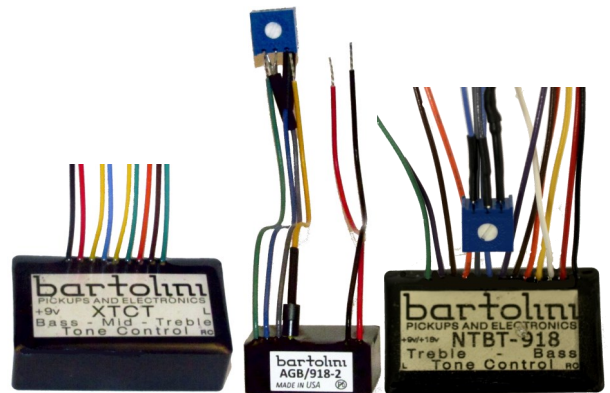

All trademarks, trade names, or logos mentioned or used are the property of their respective owners.

Every effort has been made to properly capitalize, punctuate, identify and attribute trademarks and trade names to their respective owners, including the use of ® and ™ wherever possible and practical. Bartolini, Inc. makes no warranty, express or implied, or assumes any legal liability or responsibility for the accuracy, completeness, or usefulness of any information, apparatus, product, or process disclosed, or your use of such information.

Bartolini® is a registered trademark of Bartolini, Inc.

Strat, J Bass and P Bass are registered trademarks of Fender Musical Instruments Corp. Bartolini is not affiliated with FMIC.

Rickenbacker is a registered trademark of Rickenbacker International Corporation. Bartolini is not affiliated with RIC.

MightyMite is a registered trademark of MightyMite Parts. Bartolini is not affiliated with MightyMite.

Musical Man is a registered trademark of Ernie Ball, Inc. Bartolini is not affiliated with EBI.

Johnny Smith is a Model from Gibson Guitar Corp. Bartolini is not affiliated with Gibson.



