

2018-2020 Deluxe



SERVICE MANUAL

SRAM LLC WARRANTY

EXTENT OF LIMITED WARRANTY

Except as otherwise set forth herein, SRAM warrants its products to be free from defects in materials or workmanship for a period of two years after original purchase. This warranty only applies to the original owner and is not transferable. Claims under this warranty must be made through the retailer where the bicycle or the SRAM component was purchased. Original proof of purchase is required. **Except as described herein, SRAM makes no other warranties, guaranties, or representations of any type (express or implied), and all warranties (including any implied warranties of reasonable care, merchantability, or fitness for a particular purpose) are hereby disclaimed.**

LOCAL LAW

This warranty statement gives the customer specific legal rights. The customer may also have other rights which vary from state to state (USA), from province to province (Canada), and from country to country elsewhere in the world.

To the extent that this warranty statement is inconsistent with the local law, this warranty shall be deemed modified to be consistent with such law, under such local law, certain disclaimers and limitations of this warranty statement may apply to the customer. For example, some states in the United States of America, as well as some governments outside of the United States (including provinces in Canada) may:

- a. Preclude the disclaimers and limitations of this warranty statement from limiting the statutory rights of the consumer (e.g. United Kingdom).
- b. Otherwise restrict the ability of a manufacturer to enforce such disclaimers or limitations.

For Australian customers:

This SRAM limited warranty is provided in Australia by SRAM LLC, 1000 W. Fulton Market, 4th Floor, Chicago, IL, 60607, USA. To make a warranty claim please contact the retailer from whom you purchased this SRAM product. Alternatively, you may make a claim by contacting SRAM Australia, 6 Marco Court, Rowville 3178, Australia. For valid claims SRAM will, at its option, either repair or replace your SRAM product. Any expenses incurred in making the warranty claim are your responsibility. The benefits given by this warranty are additional to other rights and remedies that you may have under laws relating to our products. Our goods come with guarantees that cannot be excluded under the Australian Consumer Law. You are entitled to a replacement or refund for a major failure and for compensation for any other reasonably foreseeable loss or damage. You are also entitled to have the goods repaired or replaced if the goods fail to be of acceptable quality and the failure does not amount to a major failure.

LIMITATIONS OF LIABILITY

To the extent allowed by local law, except for the obligations specifically set forth in this warranty statement, in no event shall SRAM or its third party suppliers be liable for direct, indirect, special, incidental, or consequential damages.

LIMITATIONS OF WARRANTY

This warranty does not apply to products that have been incorrectly installed and/or adjusted according to the respective SRAM user manual. The SRAM user manuals can be found online at sram.com, rockshox.com, avidbike.com, truvativ.com, or zipp.com.

This warranty does not apply to damage to the product caused by a crash, impact, abuse of the product, non-compliance with manufacturers specifications of usage or any other circumstances in which the product has been subjected to forces or loads beyond its design.

This warranty does not apply when the product has been modified, including, but not limited to any attempt to open or repair any electronic and electronic related components, including the motor, controller, battery packs, wiring harnesses, switches, and chargers.

This warranty does not apply when the serial number or production code has been deliberately altered, defaced or removed.

This warranty does not apply to normal wear and tear. Wear and tear parts are subject to damage as a result of normal use, failure to service according to SRAM recommendations and/or riding or installation in conditions or applications other than recommended.

Wear and tear parts are identified as:

- | | | | |
|---|--|--------------------------|----------------------|
| • Dust seals | • Stripped threads/bolts (aluminium, titanium, magnesium or steel) | • Handlebar grips | • Transmission gears |
| • Bushings | • Brake sleeves | • Shifter grips | • Spokes |
| • Air sealing o-rings | • Brake pads | • Jockey wheels | • Free hubs |
| • Glide rings | • Chains | • Disc brake rotors | • Aero bar pads |
| • Rubber moving parts | • Sprockets | • Wheel braking surfaces | • Corrosion |
| • Foam rings | • Cassettes | • Bottomout pads | • Tools |
| • Rear shock mounting hardware and main seals | • Shifter and brake cables (inner and outer) | • Bearings | • Motors |
| • Upper tubes (stanchions) | | • Bearing races | • Batteries |
| | | • Pawls | |

Notwithstanding anything else set forth herein, the battery pack and charger warranty does not include damage from power surges, use of improper charger, improper maintenance, or such other misuse.

This warranty shall not cover damages caused by the use of parts of different manufacturers.

This warranty shall not cover damages caused by the use of parts that are not compatible, suitable and/or authorised by SRAM for use with SRAM components.

This warranty shall not cover damages resulting from commercial (rental) use.



SAFETY FIRST!

We care about YOU. Please, always wear your safety glasses and protective gloves when servicing RockShox products.

Protect yourself! Wear your safety gear!

TABLE OF CONTENTS

GETTING STARTED.....	6
RECOMMENDED SERVICE INTERVALS.....	6
RECORD YOUR SETTINGS.....	6
TORQUE VALUES.....	6
COMPREHENSIVE PARTS, TOOLS, AND SUPPLIES LIST.....	7
EXPLODED VIEW - DELUXE ULTIMATE RCT / NUDE.....	8
EXPLODED VIEW - DELUXE RT3/RT/RL/R/DELUXE SELECT+/SELECT.....	9
EXPLODED VIEW - DELUXE RLR / ULTIMATE REMOTE.....	10
EXPLODED VIEW - DELUXE BEARING MOUNT.....	10
REMOTE CABLE AND HOUSING REMOVAL - RLR AND ULTIMATE REMOTE ONLY.....	11
PARTS, TOOLS, AND SUPPLIES.....	11
REMOTE CABLE AND HOUSING REMOVAL.....	11
SHOCK EYELET SERVICE.....	12
MOUNTING HARDWARE AND BUSHING SERVICE.....	12
PARTS, TOOLS, AND SUPPLIES.....	12
MOUNTING HARDWARE REMOVAL.....	12
EYELET BUSHING REMOVAL.....	15
BEARING MOUNT SERVICE.....	16
PARTS, TOOLS, AND SUPPLIES.....	16
BEARING REMOVAL.....	16
BEARING INSTALLATION.....	18
DAMPER BEARING REPLACEMENT.....	20
DELUXE SERVICE.....	21
PARTS, TOOLS AND SUPPLIES.....	21
50/200 HOUR SERVICE	
AIR CAN REMOVAL.....	22
BOTTOMLESS TUNING.....	25
AIR CAN SERVICE.....	27
200 HOUR SERVICE	
DAMPER BODY SERVICE.....	31
PISTON SERVICE.....	33
IFP AND DAMPER BODY SERVICE.....	41
SHOCK ASSEMBLY AND BLEED.....	43
REMOTE SPRING SERVICE - RLR/ULTIMATE REMOTE.....	46
50/200 HOUR SERVICE	
AIR CAN INSTALLATION.....	49
SHOCK EYELET ASSEMBLY.....	51
EYELET BUSHING INSTALLATION.....	51
MOUNTING HARDWARE INSTALLATION.....	52
REMOTE CABLE AND HOUSING INSTALLATION - RLR/ULTIMATE REMOTE.....	54
PARTS, TOOLS, AND SUPPLIES.....	54
REMOTE CABLE AND HOUSING INSTALLATION.....	54

RockShox Service

We recommend that you have your RockShox suspension serviced by a qualified bicycle mechanic. Servicing RockShox suspension requires knowledge of suspension components, as well as the use of specialized tools and lubricants/fluids. Failure to follow the procedures outlined in this service manual may cause damage to your component and void the warranty.

Visit www.sram.com/service for the latest RockShox Spare Parts catalog and technical information. For order information, please contact your local SRAM distributor or dealer.

Information contained in this publication is subject to change at any time without prior notice.

Your product's appearance may differ from the pictures contained in this publication.



For recycling and environmental compliance information, please visit www.sram.com/company/environment.

Part Preparation

Remove the component from the bicycle before service.

Disconnect and remove the remote cable or hydraulic hose from the fork or rear shock, if applicable. Instructions to remove the remote cable and housing can be found in the [Remote Cable and Housing Removal](#) section. For additional information about RockShox remotes, user manuals are available at www.sram.com/service.

Clean the exterior of the product with mild soap and water to avoid contamination of internal sealing part surfaces.

Service Procedures

The following procedures should be performed throughout service, unless otherwise specified.

Clean the part with RockShox Suspension Cleaner or isopropyl alcohol and a clean, lint-free shop towel.

Clean the sealing surface on the part and inspect it for scratches.



Replace the o-ring or seal with a new one from the service kit. Use your fingers or a pick to pierce and remove the old seal or o-ring.

Apply RockShox Dynamic Seal Grease to the new seal or o-ring. If a brush is used to apply grease, confirm there are no loose bristles in the grease or on the part.

NOTICE

Do not scratch any sealing surfaces when servicing the product. Scratches can cause leaks. Consult the spare parts catalog to replace the damaged part.



To prevent damage to the shock, use aluminum soft jaws and position the eyelet in the vise so that the adjustment knobs are clear of the vise jaws. For bearing mount shocks, wrap a shop towel around the eyelet, then clamp the eyelet flat into the vise.

Tighten the part with a torque wrench to the torque value listed in the red bar. When using a crowfoot socket and torque wrench, install the crowfoot socket at 90 degrees to the torque wrench.



Getting Started

Recommended Service Intervals

Regular service is required to keep your RockShox product working at peak performance. Follow this maintenance schedule and install the service parts included in each service kit that corresponds with the Service Hours Interval recommendation below. For spare part kit contents and details, refer to the RockShox Spare Parts Catalog at www.sram.com/service.

Service Hours Interval	Maintenance	Benefit
Every ride	Clean dirt from shock damper body	Extends wiper seal lifespan
		Minimizes damage to shock damper body
		Minimizes air can contamination
Every 50 Hours	Perform air can service	Reduces friction
		Restores small bump sensitivity
Every 200 Hours	Perform damper and spring service	Extends suspension lifespan
		Restores damping performance

Record Your Settings

Use the charts below to record your shock settings to return your shock to its pre-service settings. Record your service date to track service intervals.

Service Hours Interval	Date of Service	Air Pressure	Rebound setting - count the number of clicks while turning the rebound adjuster fully counter-clockwise.
50			
100			
150			
200			

Torque Values

Part	Tool	Torque
Air can (shaft eyelet)	13 mm crowfoot	4.5 N•m (40 in-lb)
Piston nut	RCT / RT3, 2019-2020 RL / RT: 12 mm socket 2018 RLR / RL / RT; 2018-2020 R: 10 mm socket NUDE: NUDE Piston Bolt Socket	RCT / NUDE: 6.2 N•m (55 in-lb) 2018-2020 RT3 / RLR/ RL / RT / R: 4.5 N•m (40 in-lb)
Lock Piston (RCT / NUDE)	RCT / NUDE Lock Piston Tool	4.5 N•m (40 in-lb)
Seal head/air piston	17 mm crowfoot	28 N•m (248 in-lb)
Ferrule lock screw (RLR only)	2 mm hex	0.9 N•m (7 in-lb)
Cable set screw (RLR only)	2 mm hex	0.8 N•m (7 in-lb)
Cable spool cap (RLR only)	T25 TORX	0.75 N•m (6-7 in-lb)

Parts

- Deluxe Service Kit - 50 hours
- Deluxe Service Kit - 200 hours
- Deluxe Remote Service Kit - 200 hours
- Deluxe Remote Spring Service Kit
- Rear Shock Bearing Kit - Deluxe/Super Deluxe
- Eyelet Bearing Deluxe/Super Deluxe (Damper body only)
- Shift cable and housing

Safety and Protection Supplies

- Apron
- Clean, lint-free shop towels
- Nitrile gloves
- Oil pan
- Safety glasses

Lubricants and Fluids

- Isopropyl alcohol
- RockShox Dynamic Seal Grease
- Maxima Extra 15w50 Suspension Oil
- Maxima PLUSH 7wt Suspension Oil
- Loctite Threadlocker Blue 242

Bicycle Tools

- Schrader valve core tool
- High Pressure Shock Pump 600 psi

RockShox Tools

- RockShox 1/2" x 1/2" rear shock bushing removal/installation tool
- RockShox Air Valve Adapter Tool - Rear Shock
- RockShox Deluxe IFP Height Tool
- RockShox NUDE Piston Bolt Socket
- RockShox RCT / NUDE Lock Piston Tool
- RockShox Rear Shock Vise Block
- RockShox Rear Shock Body Vise Block

Common Tools

- Adjustable wrench
- Bearing press tool: 22 mm (OD) x 10 mm (ID)
- Bench vise with aluminium soft jaws
- Cable and housing cutters
- Crowfoot socket wrenches: 13 mm, 17 mm
- Hammer
- Hex wrenches: 1.5 mm, 2 mm, 3 mm
- Hex bit sockets: 1.5 mm, 2 mm, 3 mm
- Metric caliper or small metric ruler
- Needle nose pliers
- Open end wrenches: 13 mm, 17 mm
- Pick
- Socket wrenches: 10 mm (**RLR/R, 2018 RL/RT**) and 12 mm (**RCT/RT3, 2019 RL/RT**)
- Small diameter punch
- Strap wrench
- Torque wrench
- TORX wrench: T25

Ultimate RCT (2020)

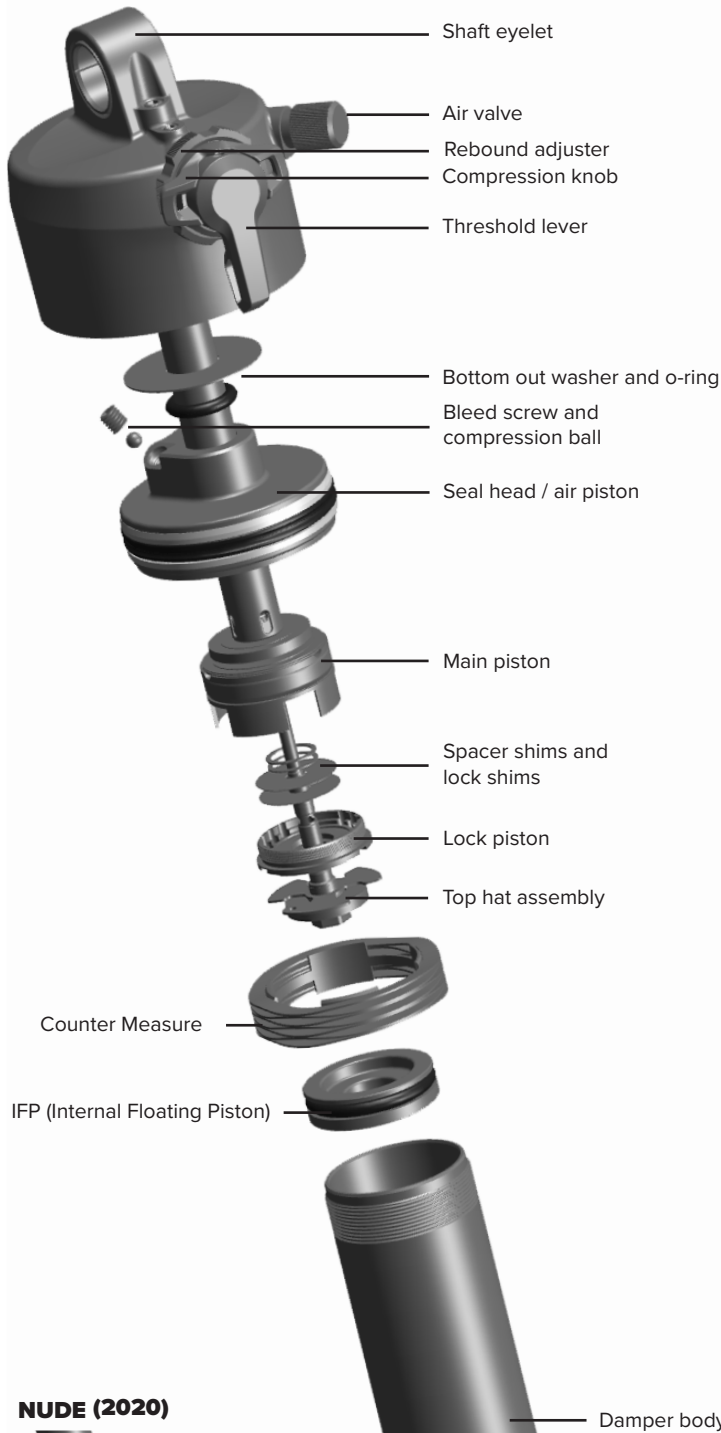

NUDE (2020)

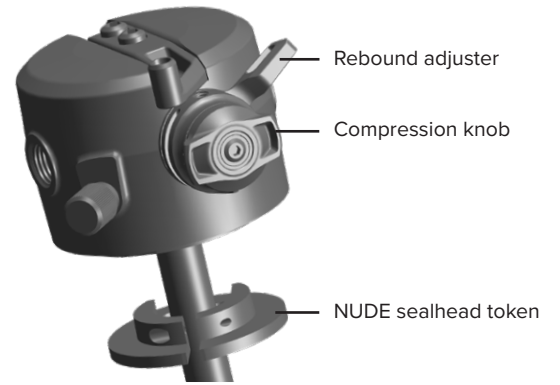

Air Can



NUDE (2020)

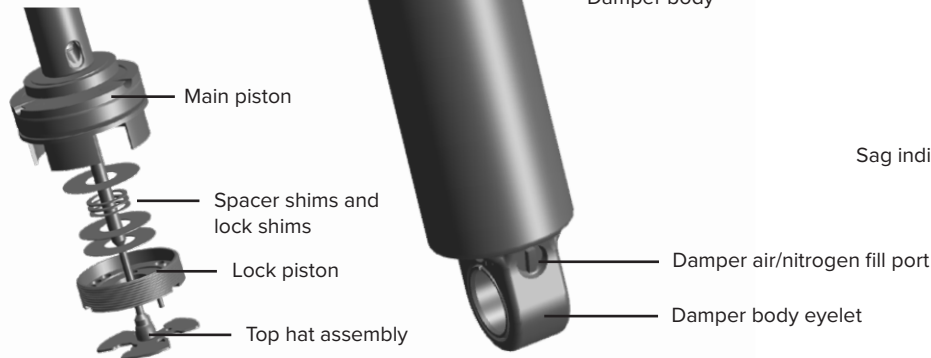

Select + (2020)
RT3 (2018-2020)
RL/ RT (2018-2018)

Select (2020)
R (2018-2020)

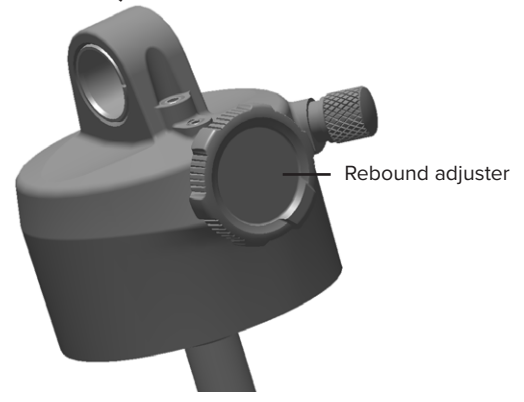
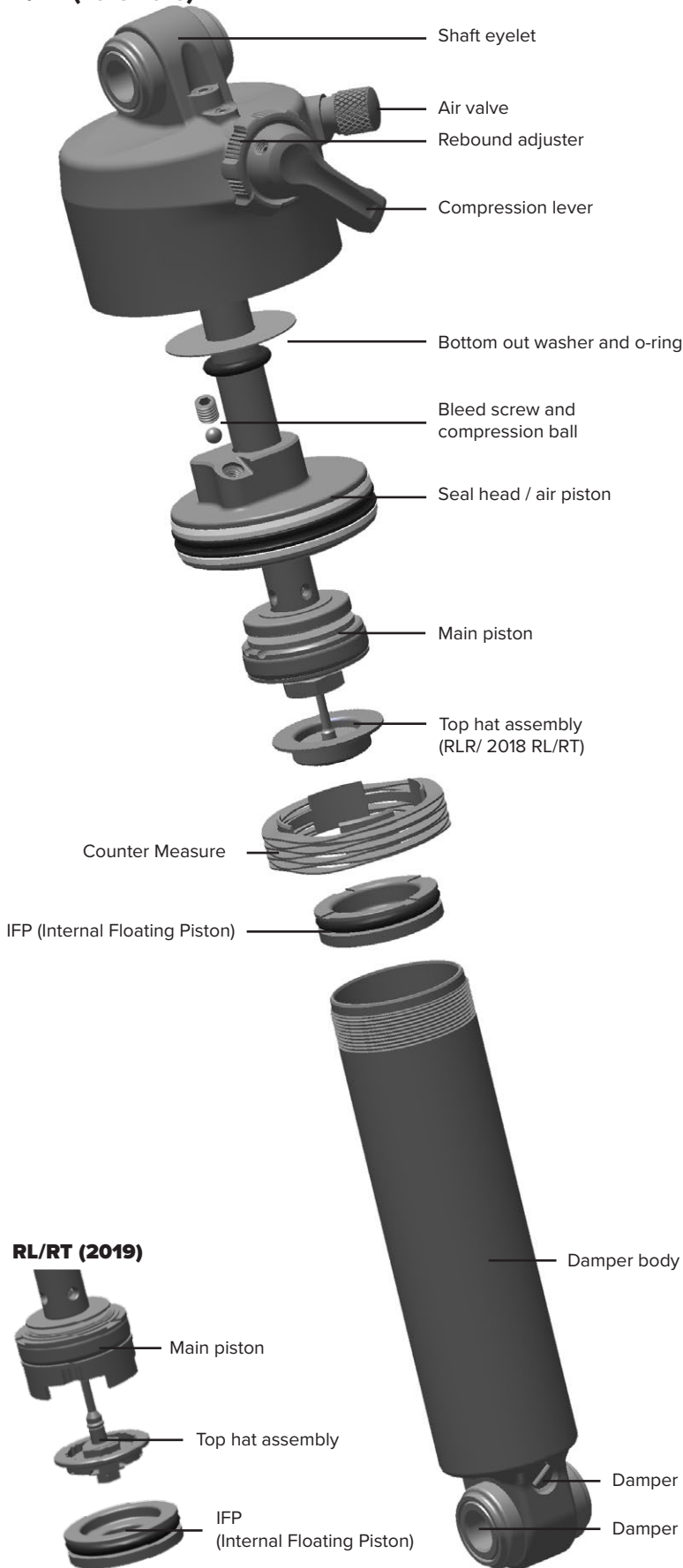

Air Can

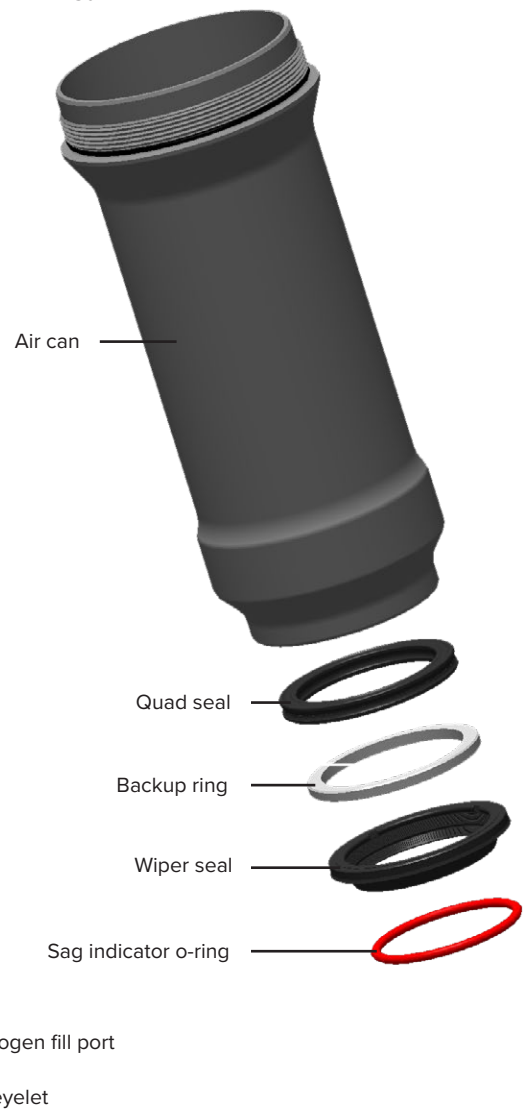

**Ultimate Remote (2020)
RLR (2018-2019)**

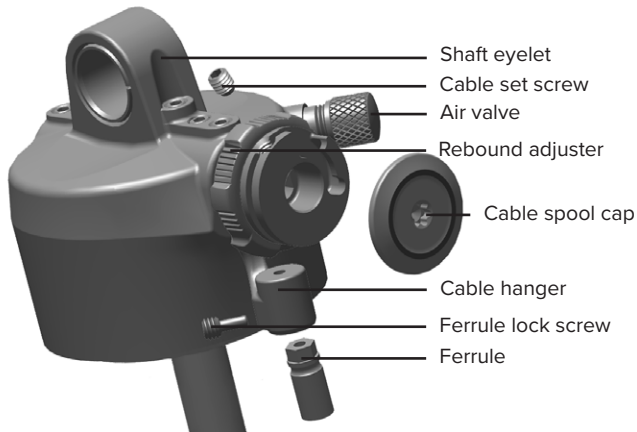

Remote Spring

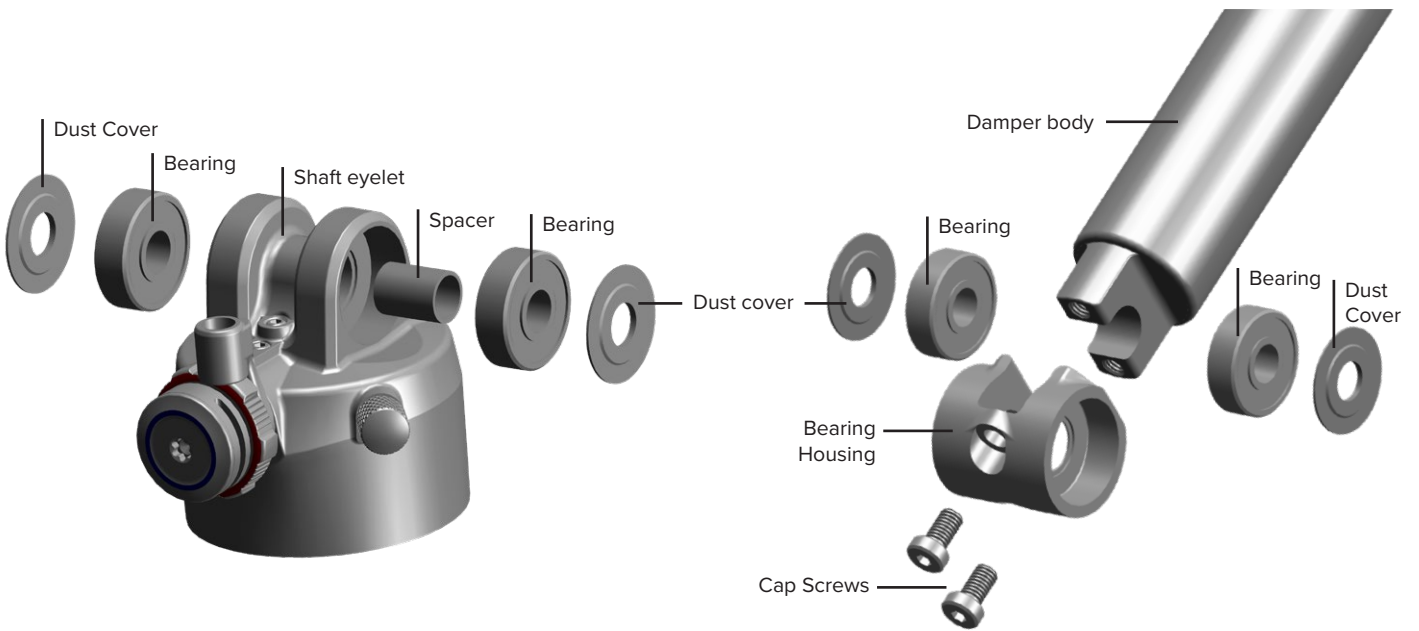
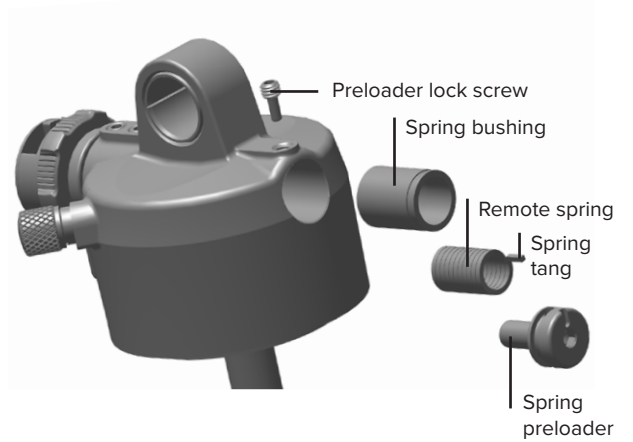

Remote Cable and Housing Removal - RLR and Ultimate Remote Only

Prior to servicing the rear shock, remove the remote cable and housing from the shock, then remove the shock from the bicycle frame according to the bicycle manufacturer's instructions. Replace the cable and housing after performing shock service (see the [Remote Cable and Housing Installation - RLR Only](#) section).

Parts, Tools, and Supplies

Safety and Protection Supplies

- Nitrile gloves
- Safety glasses

Common Tools

- Cable and housing cutters
- Hex wrench: 2 mm
- TORX wrench: T25

Remote Cable and Housing Removal

- 1** Use a T25 mm hex wrench to remove the cable spool cap.
The cable spool will rotate with the spool cap. Continue to rotate the spool cap counter-clockwise until it begins to loosen.



- 2** Use a 2 mm hex wrench to loosen the cable set screw, then use cable and housing cutters to cut the cable.
Use a 2 mm hex wrench to loosen the ferrule lock screw. Remove the ferrule, housing, and cable from the cable bracket.
Discard the cable, housing, and ferrule.



Shock Eyelet Service

Mounting Hardware and Bushing Service

Prior to servicing the rear shock, remove it from the bicycle frame according to the bicycle manufacturer's instructions. Once the shock is removed from the bicycle, remove the mounting hardware before performing any service.

Parts, Tools, and Supplies

Parts

- Deluxe Service Kit - 50 hours
- Deluxe Service Kit - 200 hours
- Deluxe Remote Service Kit - 200 hours

Safety and Protection Supplies

- Apron
- Clean, lint-free shop towels
- Nitrile gloves
- Safety glasses

RockShox Tools

- RockShox 1/2" x 1/2" rear shock bushing removal/installation tool

Lubricants and Fluids

- RockShox Dynamic Seal Grease

Common Tools

- Bench vise with aluminium soft jaws
- Open end wrenches: 13 mm (2)
- Adjustable wrench

Mounting Hardware Removal

NOTICE

To prevent damage to the shock, use aluminium soft jaws and position the eyelet in the vise so that the adjustment knobs are clear of the vise jaws.

Some mounting hardware is easily removed using only your fingers. Try to remove the end spacers with your fingernail or small screwdriver, then push the bushing pin out of the bushing. If this works, continue to the next section.

If you are unable to remove the mounting hardware using your fingers, use the RockShox rear shock bushing removal/installation tool.



- 1 Thread the small end of the push pin onto the threaded rod until the rod is flush or slightly protrudes from the hex-shaped end of the push pin.

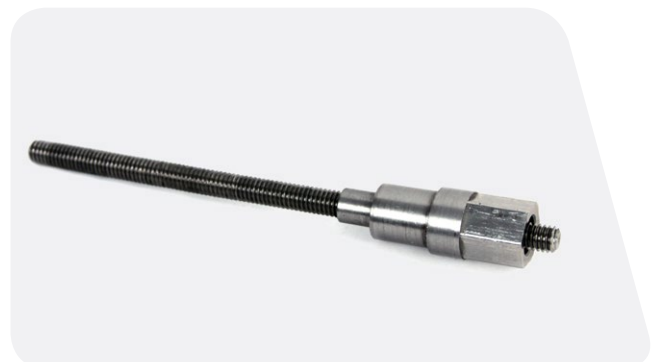

- 2** Insert the threaded rod through the shaft eyelet until the push pin rests against the bushing pin.

Thread the large, open end of the catcher along the rod until it rests on the end spacer.



- 3** Clamp the catcher in a vise or hold it secure with a 13 mm open end or adjustable wrench.

NOTICE

Do not scratch the air can as you turn the wrench.

Use a second 13 mm wrench to thread the push pin along the rod until it stops against the end spacer.

Unthread the push pin from the threaded rod to remove the end spacer and the bushing pivot pin.



- 4** If the bushing pin does not remove easily, reinsert the threaded rod and push pin through the eyelet shaft.

Thread the large, open end of the catcher along the rod until it rests against the shaft eyelet.

Use a 13 mm wrench to thread the push pin along the rod until it stops against the end spacer.



- 5** Unthread the catcher from the threaded rod.
Remove the end spacer and bushing pin from the tool.
Repeat steps 2-4 for the damper eyelet.
Set the mounting hardware aside until you have finished servicing the shock.



Eyelet Bushing Removal

To replace damaged or worn out bushings, use the RockShox rear shock bushing removal/installation tool.

- 1** Insert the threaded rod through the shaft eyelet until the base of the push pin rests against the bushing.
Thread the large, open end of the catcher onto the rod until it rests on the eyelet.



- 2** Clamp the catcher in a vise or hold it secure with a 13 mm wrench.
Use a second 13 mm wrench to thread the push pin along the rod until the push pin pushes the eyelet bushing out of the eyelet.



- 3** Unthread the catcher from the threaded rod. Remove the tool from the shaft eyelet and discard the old bushing.
Repeat steps 1-3 for the other eyelet.
Set the bushings aside until you have finished servicing your shock.



Bearing Mount Service

Replace the bearings if they are not spinning freely, or if they are making a creaking noise.

Parts, Tools, and Supplies

Parts

- Rear Shock Bearing Kit - Deluxe/Super Deluxe
- Eyelet Bearing Deluxe/Super Deluxe (Damper body only)

Safety and Protection Supplies

- Apron
- Clean, lint-free shop towels
- Nitrile gloves
- Safety glasses

Common Tools

- Bearing press tool: 22 mm (OD) x 10 mm (ID)
- Hammer
- Small diameter punch
- Vise with soft jaws

Bearing Removal

- 1 Remove the dust cover.



- 2 To prevent damage to the air valve, remove the bearing on the side opposite of the air valve first. Place a punch against the back of the opposite bearing, and tap out the bearing.



- 3 Turn the shock over and place the punch against the back of the other bearing, and tap out the bearing.

NOTICE

Do not damage the air valve when tapping out the bearing.



- 4 Spray isopropyl alcohol in the bearing bores and clean them with a shop towel.



Bearing Installation

- 1 Install a new bearing into one bearing bore, then clamp the eyelet and bearing into a vise with soft jaws. Press the bearing into the bearing bore until it is flush with the eyelet.

Loosen the vise, and align the bearing press tool with the bearing, then tighten the vise. Press the bearing into the bearing bore until it stops.

NOTICE

Do not overtighten the bearing. Overtightening can damage the bearing and cause it to malfunction.

To prevent damage to the bearing, make sure that the bearing press tool contacts both the inner and outer races of the bearing.



22 mm (OD) x 10 mm (ID) bearing press tool

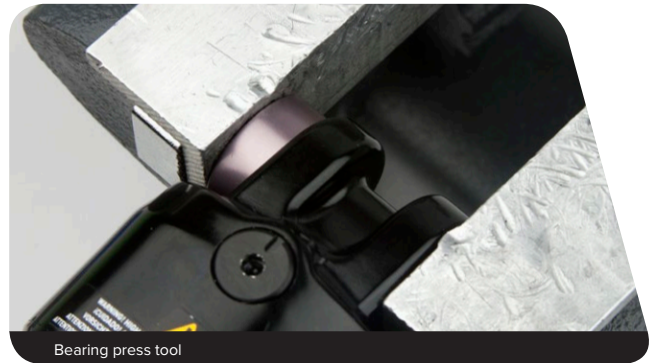

Bearing press tool

- 2 Insert a new spacer into the eyelet, then install a new bearing into the other bearing bore. Clamp the eyelet and bearing into a vise with soft jaws, then press the bearing into the bearing bore until it is flush with the eyelet.

Loosen the vise, and align the bearing press tool with the bearing, then tighten the vise. Press the bearing into the bearing bore until it stops.

NOTICE

Do not overtighten the bearing. Overtightening can damage the bearing and cause it to malfunction.

To prevent damage to the bearing, make sure that the bearing press tool contacts both the inner and outer races of the bearing.



Bearing press tool



- 3 Remove the shock from the vise. The bearings should sit approximately 1 mm below the outer edge of the bearing bore. Reinstall dust covers before installing the shock on the bicycle.



Damper Bearing Replacement

- 1 Loosen the cap screws and remove the bearing assembly from the shock.

The dust covers may fall off. This is normal.



NOTICE

If you are completing the 50 or 200 hour service, set the bearing assembly aside until service is complete. The air can cannot be removed with the bearing assembly installed.

- 2 Install the new bearing assembly and screws onto the shock. Tighten the cap screws to 6.2 N·m (55 in-lb).



Deluxe Service

Prior to servicing your rear shock, remove it from the bicycle frame according to the bicycle manufacturer's instructions. Once the shock is removed from the bicycle, remove the mounting hardware before performing any service (see the [Mounting Hardware And Bushing Service](#) section).

Parts, Tools and Supplies

Parts

- Deluxe Service Kit - 50 hours
- Deluxe Service Kit - 200 hours
- Deluxe Remote Service Kit - 200 hours
- Deluxe Remote Spring Service Kit

Safety and Protection Supplies

- Apron
- Clean, lint-free shop towels
- Nitrile gloves
- Oil pan
- Safety glasses

Lubricants and Fluids

- Isopropyl alcohol
- RockShox Dynamic Seal Grease
- Maxima Extra 15w50 Suspension Oil
- Maxima PLUSH 7wt Suspension Oil
- Loctite Threadlocker Blue 242

Bicycle Tools

- Schrader valve core tool
- High Pressure Shock Pump 600 psi

RockShox Tools

- RockShox Air Valve Adapter Tool - Rear Shock
- RockShox Deluxe IFP Height Tool
- RockShox NUDE Piston Bolt Socket
- RockShox RCT / NUDE Lock Piston Tool
- RockShox Rear Shock Vise Block
- RockShox Rear Shock Body Vise Block

Common Tools

- Bench vise with aluminium soft jaws
- Crowfoot socket wrenches: 13 mm, 17 mm
- Hex wrenches: 1.5 mm, 2 mm, 3 mm
- Hex bit sockets: 1.5 mm, 2 mm, 3 mm
- Metric caliper or small metric ruler
- Open end wrenches: 13 mm, 17 mm
- Pick
- Socket wrenches: 10 mm (**RLR/R, 2018 RL/RT**) and 12 mm (**RCT/RT3, 2019 RL/RT**)
- Strap wrench
- Torque wrench
- Needle nose pliers

⚠ WARNING

Before disassembly or service of any air system remove the air pressure from all air chambers and remove the air valve cores.

If your shock will not return to full extension, do not attempt to service or disassemble your shock. Attempting to service a shock that will not return to full extension can cause severe and/or fatal injuries.

SAFETY INSTRUCTIONS

Always wear safety glasses and nitrile gloves when working with suspension fluid.

Place an oil pan on the floor underneath the area where you will be working on the shock.

NOTICE

When replacing seals and o-rings, use your fingers or a pick to remove the seal or o-ring. Spray isopropyl alcohol on each part and clean with a shop towel. Apply grease to the new seal or o-ring. Only use RockShox Dynamic Seal Grease when servicing RockShox shocks.

To prevent damage to the shock use aluminium soft jaws and position the eyelet in the vise so that the adjustment knobs are clear of the vise jaws. For bearing mount shocks, wrap a shop towel around the eyelet, then clamp the eyelet flat into the vise.

Inspect each part for scratches. Do not scratch any sealing surfaces when servicing your suspension. Scratches can cause leaks.



1 To record your adjustment settings, turn the rebound adjuster knob counter-clockwise until it stops, while counting the number of detent clicks. This will assist you with post-service set up.

RCT/NUDE: Rotate the compression knob to the minus position.

RT3/RL/RT: Turn the compression lever to the unlocked position.

RLR: The compression circuit is unlocked by default once the remote cable is removed.

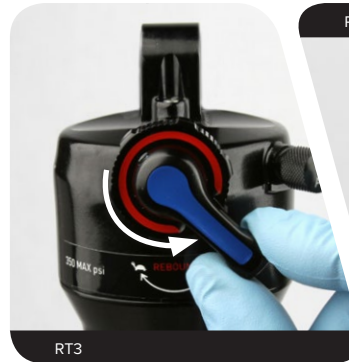
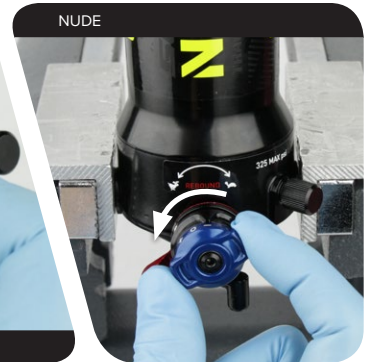

- 2** Record your air pressure setting to assist with post-service set up.
Remove the air valve cap by hand. Use a small hex wrench to lightly depress the Schrader valve and slowly release all air pressure from the air can.

⚠ CAUTION

Do not disassemble a pressurized shock, this can cause suspension fluid or debris to forcefully eject from the shock. Wear safety glasses.

Slowly release the air from the air can to make sure the air is removed from both chambers. Quickly releasing the air can trap air in the negative chamber and cause the air can to forcefully eject from the shock upon disassembly.

Use a Schrader valve tool to remove and reinstall the valve core from the valve body to make sure all air has been removed.



- 3** Clamp the shaft eyelet into a vise, with the shock positioned horizontally.



- 4** Remove the sag indicator.

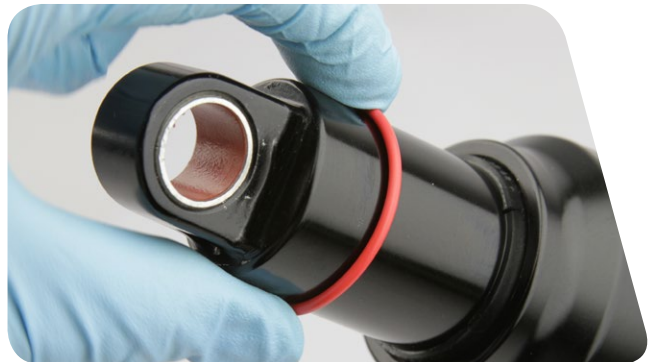

- 5 Insert a shop towel through the damper body eyelet to prevent the air can from forcefully ejecting from the shock.

⚠ CAUTION- EYE HAZARD

The air can may still have air pressure in the negative chamber, which may cause the air can to forcefully eject from the shock upon disassembly. Wear safety glasses.



- 6 Use a strap wrench to remove the air can. Wrap the strap around the section of the air can furthest from the shaft eyelet. Turn the wrench counter-clockwise to unthread the air can.

Once it is completely unthreaded, slowly pull the air can along the damper body to remove it and the Counter Measure.

Remove the shop towel from the damper body eyelet.

Vacuum pressure will increase as you pull the air can along the damper body, and will suddenly release when the air can is pulled over the air piston.

NOTICE

Do not place the strap wrench on the air can decal.



Counter Measure

Bottomless Tuning

Bottomless Tokens and Gnar Dog Tokens reduce air volume in your rear shock and create greater progression at the end of the shock's travel. Add or remove tokens to tune your shock's bottomless feel. Gnar Dog Tokens are equivalent to 2.5 Bottomless Tokens.

Bottomless Tokens	3 Tokens Max
Gnar Dog Tokens	1 Gnar Dog Token + 2 Bottomless Tokens Max

NUDE: do not remove tokens.

Sonar Tokens: Factory installed in certain Specialized shocks. Compatible with standard eyelet shocks only. Not sold separately.



Bottomless Tokens: Clamp the shaft eyelet into the vise.

Move the bottom out washer and o-ring away from the shaft eyelet, then snap the token onto the damper shaft with the tabbed side facing the air valve. Slide the token down the damper shaft until it contacts the other tokens or the eyelet. Slide the bottom out washer and o-ring onto the tokens.

Install up to three Bottomless Tokens.



Gnar Dog Token: Clamp the shaft eyelet into the vise.

Remove any existing tokens from the eyelet. Move the bottom out washer and o-ring away from the shaft eyelet, then snap the Gnar Dog Token onto the damper shaft with the flat side facing out of the eyelet. Slide the token down the damper shaft until it contacts the eyelet.

Only one Gnar Dog Token may be installed. If one Gnar Dog Token is installed, a maximum of two additional Bottomless Tokens can be installed. Slide the bottom out washer and o-ring onto the tokens.

NOTICE

The Gnar Dog Token must be the first token installed into the eyelet. Any additional Bottomless Tokens must be installed after the Gnar Dog Token is installed.



Token Removal: Clamp the shaft eyelet into the vise.

Move the bottom out washer and o-ring away from the shaft eyelet. Use a pick to separate the token from the other tokens or the shaft eyelet, then remove the token from the shaft.

NOTICE

Do not scratch the damper shaft, shaft eyelet, or the eyelet o-ring. Scratches can cause leaks.



NOTICE

When replacing seals and o-rings, use your fingers or a pick to remove the seal or o-ring. Spray isopropyl alcohol on each part and clean with a shop towel. Apply grease to the new seal or o-ring. Only use RockShox Dynamic Seal Grease when servicing RockShox shocks.

Inspect each part for scratches. Do not scratch any sealing surfaces when servicing your suspension. Scratches can cause leaks.



- 1 Use your fingers to remove the o-ring on the outside of the air can.
Spray isopropyl alcohol on the air can threads and eyelet body threads and clean them with a shop towel.
Install a new o-ring.



- 2 Use a pick to remove the air can wiper seal located in the top groove.

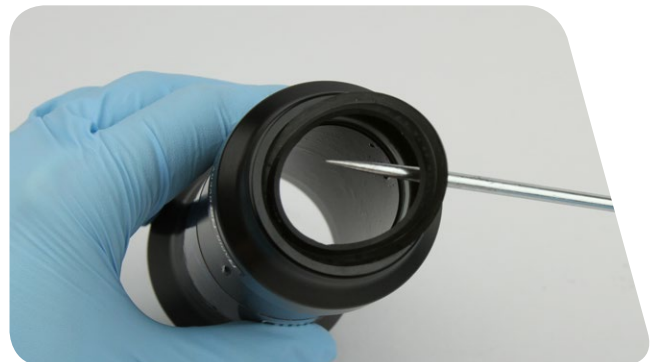

- 3** Use a pick to remove the backup ring from the second groove inside the air can.

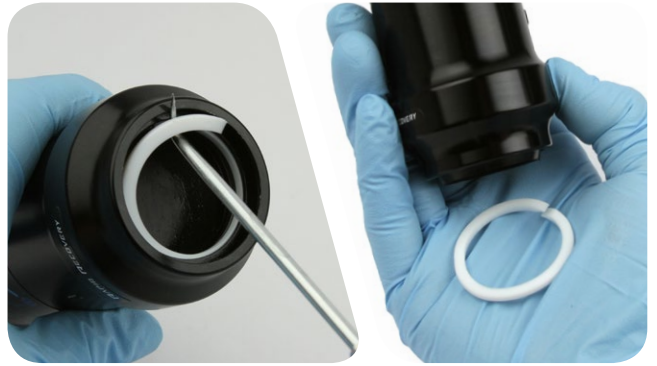

- 4** Use a pick to pierce and remove the quad seal from the bottom of the second groove in the air can.



- 5** Spray isopropyl alcohol inside the air can and clean it with a shop towel. Remove a glove and use your finger to inspect the inside and outside of the air can for scratches, dents, or other surface deformations. Replace the air can if it is scratched or damaged.

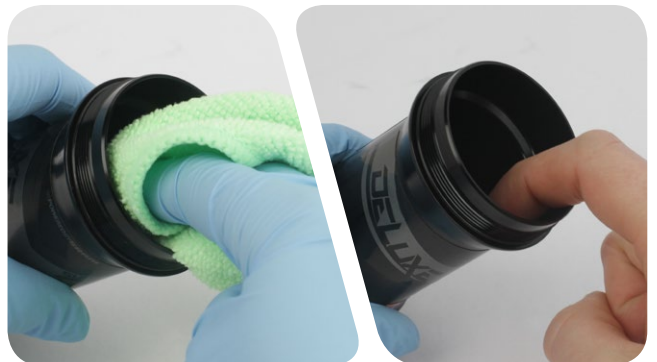

- 6** Install the quad seal by inserting one end into the deepest groove in the air can, then push the remainder of the ring into the groove.



- 7** Install the backup ring by inserting one end into the air can, then push the remainder of the ring into the can, so that it rests on top of the quad seal.



- 8** Orient the new wiper seal step side up. Install it into the wiper seal groove at the top of the air can.

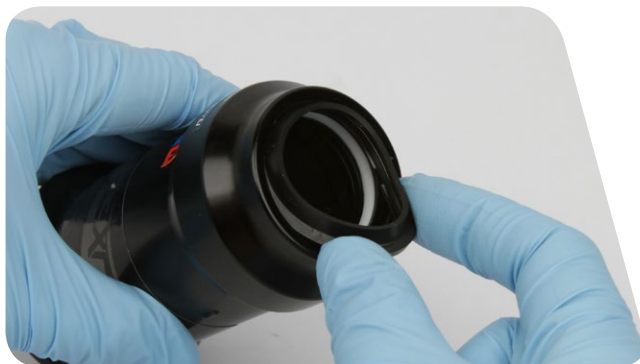

- 9** Spray isopropyl alcohol on the air can threads and eyelet body threads and clean them with a shop towel.
Apply a small amount of RockShox Dynamic Seal Grease to the quad seal, backup ring, and wiper seal.
Set the air can aside.



10 Clamp the eyelet vertically in the vise.

Use your fingers to remove the seal head/air piston seal and glide rings.

Spray isopropyl alcohol on the seal head/air piston and clean it with a shop towel.

Install the thicker glide ring below the seal head/air piston seal, and the thinner glide ring above.

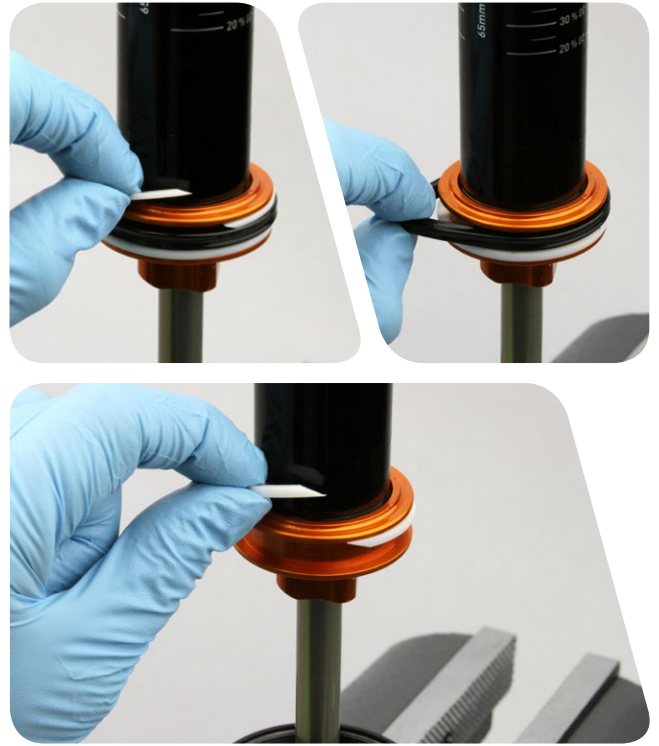

⬮ To continue with the **50 Hour Service** go to [Air Can Installation](#).

To continue with the **200 Hour Service** go to [Damper Body Service](#).

NOTICE

When replacing seals and o-rings, use your fingers or a pick to remove the seal or o-ring. Spray isopropyl alcohol on each part and clean with a shop towel. Apply grease to the new seal or o-ring. Only use RockShox Dynamic Seal Grease when servicing RockShox shocks.

To prevent damage to the shock use aluminium soft jaws and position the eyelet in the vise so that the adjustment knobs are clear of the vise jaws. For bearing mount shocks, wrap a shop towel around the eyelet, then clamp the eyelet flat into the vise.

Inspect each part for scratches. Do not scratch any sealing surfaces when servicing your suspension. Scratches can cause leaks.



- 1 Use a Schrader valve tool to remove the damper air/nitrogen fill port cap. Use a small hex wrench or pick to depress the Schrader valve and release all air pressure from the damper.

Once the pressure has been released, depress the Schrader valve a second time. If the Schrader valve is able to move, the shock has been completely depressurized.

If the Schrader valve does not move at all, the shock is still pressurized and will need to be sent to an authorized RockShox dealer for further service.

⚠ CAUTION - EYE HAZARD

Verify all pressure is removed from the shock before proceeding. Failure to do so can cause the damper body to separate from the shaft eyelet at a high velocity. Wear safety glasses.



- 2 Use a Schrader valve tool to remove and reinstall the Schrader valve core from the damper air/nitrogen fill port to make sure all air has been removed.



- 3 Remove the shock from the vise. Turn the shock over and clamp the damper eyelet into the vise.



- 4 NUDE:** Use a 1.5 mm hex wrench to loosen the set screw and remove the NUDE Seal Head Token if installed.



- 5** Use a 2 mm hex wrench to remove the bleed screw, located in the seal head/air piston.

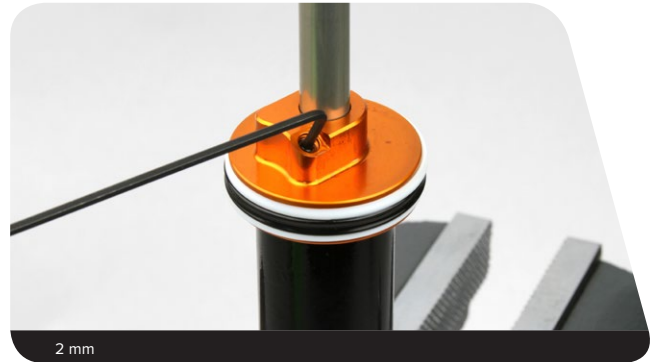

- 6** Wrap a shop towel around the damper body.
Use a 17 mm open end wrench to loosen the seal head/air piston assembly from the damper body. Use your hand to remove the assembly.

⚠ CAUTION - EYE HAZARD

If fluid is foaming from the damper body when the seal head/air piston is loosened, the IFP seal has failed and the fluid inside the damper is pressurized. This can cause the seal head/air piston assembly and damper fluid to forcefully eject from the damper body. Cover the seal head/air piston assembly with a shop towel and slowly loosen the assembly to allow the pressurized fluid to leak out between the damper body and seal head/air piston assembly.

Fluid will spill from the damper body.

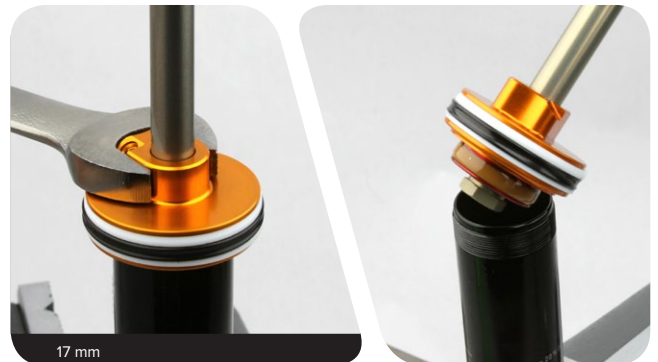

- 7** Remove the damper body from the vise and pour the fluid into an oil pan.



NOTICE

When replacing seals and o-rings, use your fingers or a pick to remove the seal or o-ring. Spray isopropyl alcohol on each part and clean with a shop towel. Apply grease to the new seal or o-ring. Only use RockShox Dynamic Seal Grease when servicing RockShox shocks.

To prevent damage to the shock use aluminium soft jaws and position the eyelet in the vise so that the adjustment knobs are clear of the vise jaws. For bearing mount shocks, wrap a shop towel around the eyelet, then clamp the eyelet flat into the vise.

Inspect each part for scratches. Do not scratch any sealing surfaces when servicing your suspension. Scratches can cause leaks.



1 Spray isopropyl alcohol on the shaft assembly and vice blocks and clean them with a shop towel.

2 Use a vise block with the 10 mm shaft clamp to clamp the shaft into a vise.

Do not remove the shaft from the eyelet.

NOTICE

To prevent damage to the seal head/air piston, position the shaft in the vise so that the piston is clear of the vise jaws.



3 RCT/NUDE: Use needle nose pliers to remove the compression rod and top cap assembly.

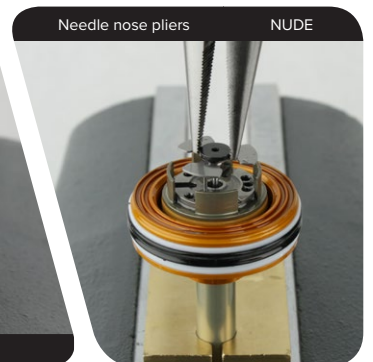

NOTICE

RCT: Do not allow the detent ball to separate from the compression rod.

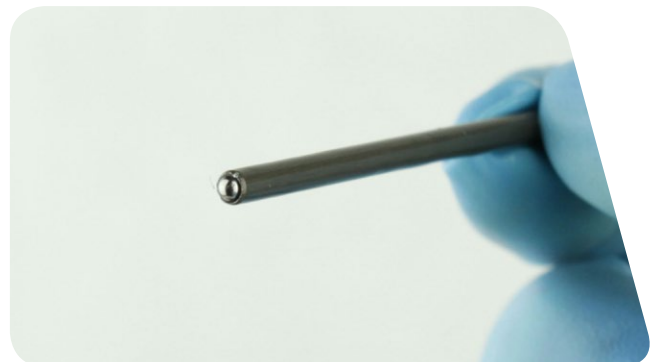

RLR/RL/RT: Use your fingers to remove the compression rod and top cap assembly.

Keep all the parts together and set them aside.

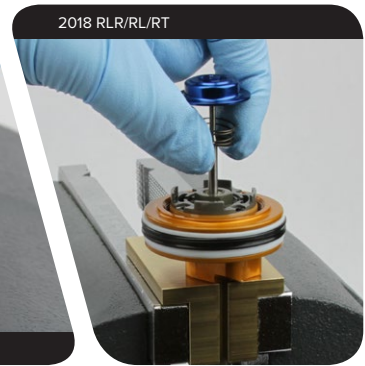

- 4** **RLR/RL/RT:** Use a pick to remove the compression rod o-rings. Install new o-rings onto the compression rod.



- 5** **RCT/NUDE:** Align the guide pin on the piston with the guide hole in the RCT / NUDE Lock Piston Tool, then remove the lock piston from the piston assembly.

NOTICE
Apply pressure to the RCT / NUDE Lock Piston Tool when removing the lock piston to prevent the tool from slipping on the piston and damaging the guide pin.

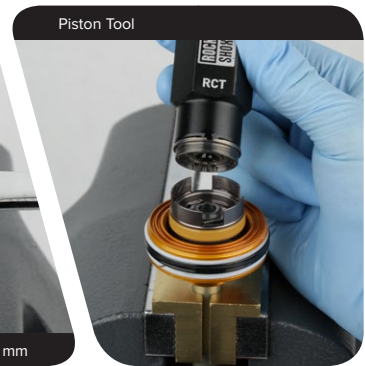
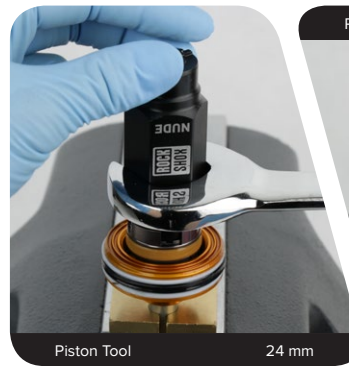
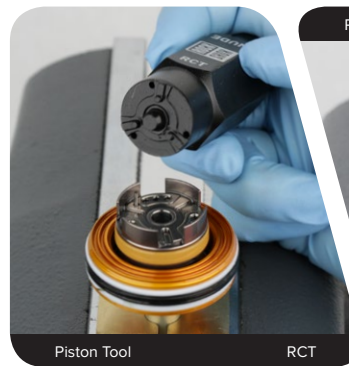

6 RCT/NUDE: Remove the spacer shims from the piston nut, then set the lock piston, lock shim(s), and spacer shims aside in the order they were removed from the piston.

The lock shim may stick to the underside of the lock piston. This is normal.

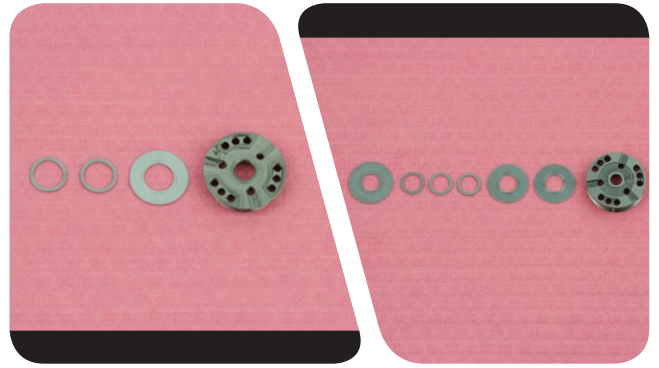

7 RCT/RT3; 2019-2020 RL/RT: Use a 12 mm socket wrench to remove the piston nut.

RCT: Only loosen the piston bolt, do not remove it completely from the piston assembly.

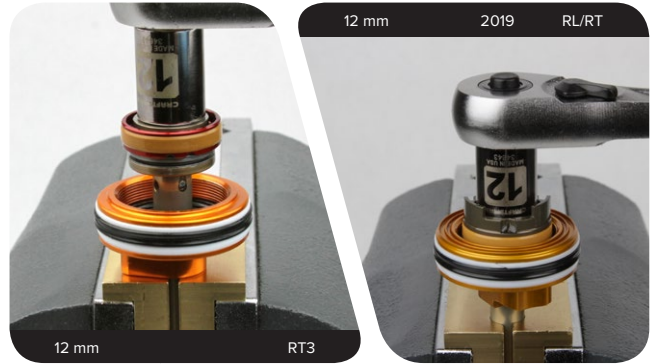

NUDE: Use a NUDE Piston Bolt Socket to loosen the piston bolt.

Only loosen the piston bolt, do not remove it completely from the piston assembly.

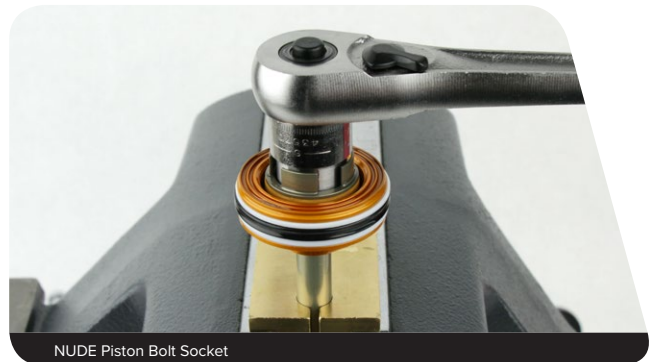

2018 RLR/RL/RT; 2018-2020 R: Use a 10 mm socket wrench to remove the piston nut.



8 Use a small wrench or pick to slide the main piston assembly off the shaft and onto the tool.

RCT/NUDE: Keep the piston bolt with the piston assembly.

NOTICE

Keep all the parts together and set them aside. If the main piston assembly is disassembled, it will need to be replaced.

RCT: Only use a ball end wrench to remove the piston assembly. Use of a pick can cause damage to the o-ring inside the piston assembly.

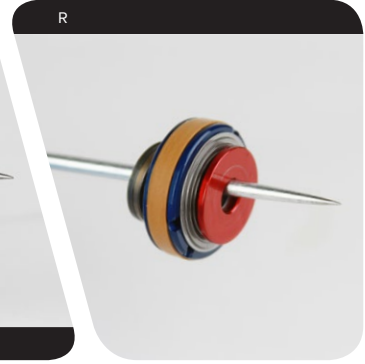
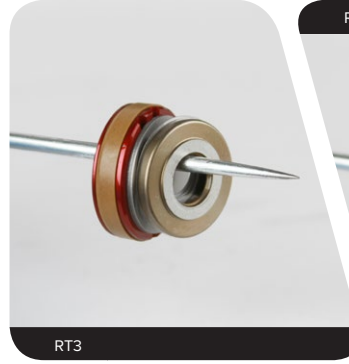
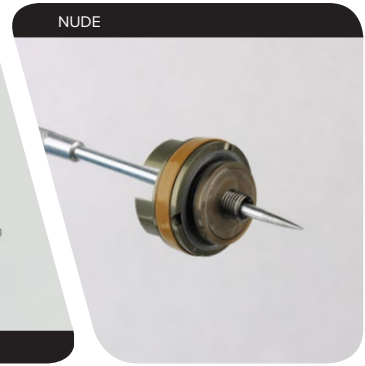
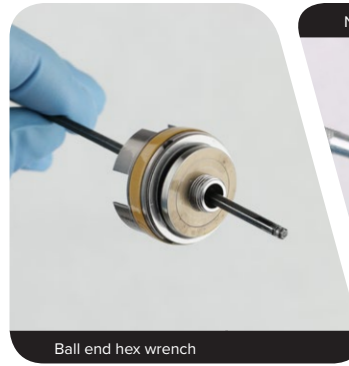

9 Remove the seal head/air piston from the damper shaft.



- 10** Remove the bottom out o-ring from the damper shaft.
Install a new o-ring.

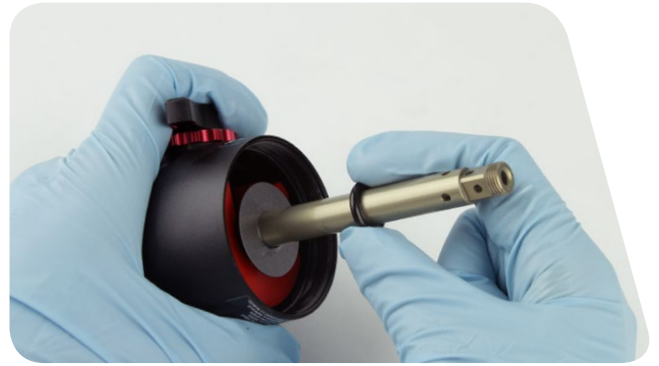

- 11** Use a pick to pierce and remove the internal seal o-ring located in the internal seal gland.
Install a new internal seal o-ring into the seal gland.

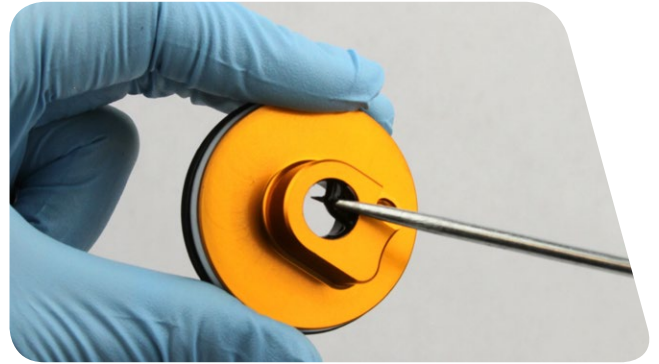

- 12** Use a pick to remove the inner o-ring, located at the base of the threads in the seal head/air piston.
Install a new inner o-ring into the seal head/air piston.

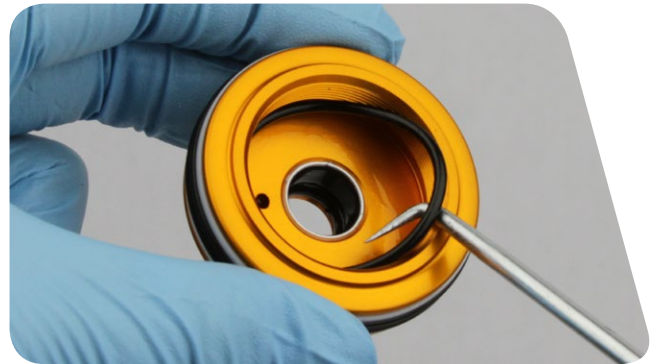

- 13** Use a 1.5 mm hex wrench to push the compression ball out of the backside of the seal head through the bleed port.

Do not replace the compression ball at this time; you will replace it later.

Do not reuse the compression ball.

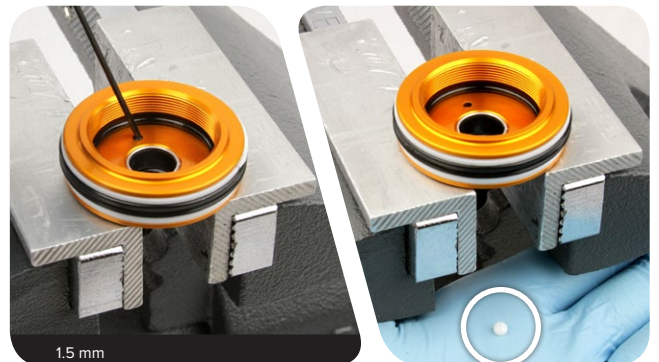

14 Use your fingers to remove the o-ring located inside the shaft eyelet threads.

Install a new o-ring inside the shaft eyelet threads.

NUDE: do not remove the o-ring.



15 Install the seal head/air piston onto the damper shaft.



16 Use a vise block with the 10 mm shaft clamp to clamp the shaft into a vise.

NOTICE

To prevent damage to the seal head/air piston, position the shaft in the vise so that the piston is clear of the vise jaws.

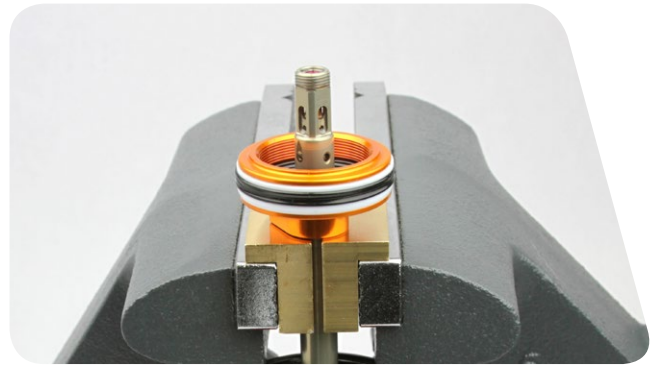

17 Install the main piston assembly that was removed in step 5 onto the damper shaft. Use your fingers to squeeze the shims and center the shim stack under the main piston. Use a small pick to center the shim stack along the inside edge of the main piston.

Be sure to keep the main piston assembly parts in the same order.

NOTICE

If the shims are not centered and in the correct order, the shock will not perform properly.

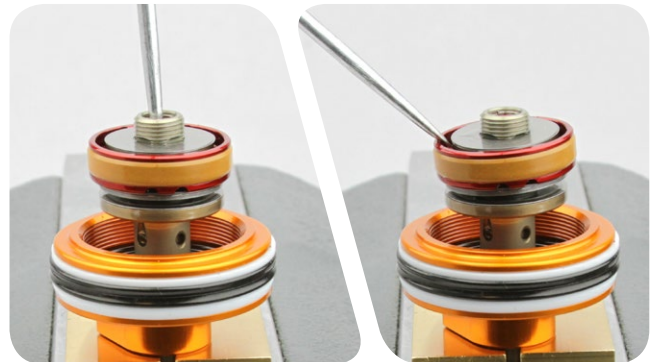

18 Spray isopropyl alcohol on the piston nut threads and clean it with a shop towel.

RT3/RLR/RL/RT/R: Apply a thin layer of Loctite Threadlocker Blue 242 only on the threads of the piston nut, then thread the nut onto the damper shaft with the stepped side facing the shims.

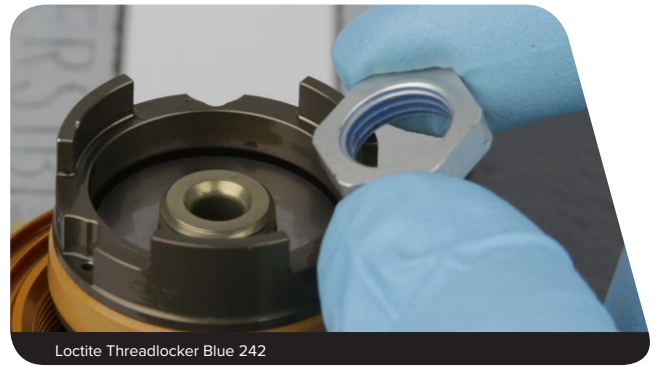

RCT: Use a torque wrench with a 12 mm socket to tighten the bolt to 6.2 N-m (55 in-lb).



NUDE: Use a torque wrench with a NUDE Piston Bolt Socket to tighten the bolt to 6.2 N-m (55 in-lb).



RT3; 2019-2020 RL/RT: Use a torque wrench with a 12 mm socket to tighten the nut to 4.5 N-m (40 in-lb).



2018 RLR/RL/RT/R: Use a torque wrench with a 10 mm socket to tighten the nut to 4.5 N-m (40 in-lb).



Remove the assembly from the vise.

19 RCT/NUDE: Install the spacer shims, lock shim(s), and lock piston, in that order, onto the piston assembly, making sure each item is centered on the piston bolt.

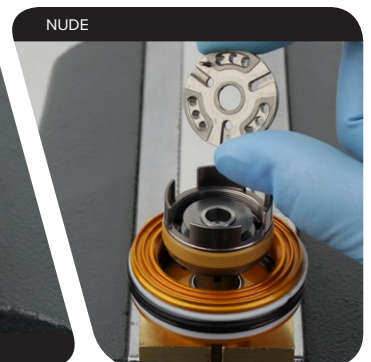
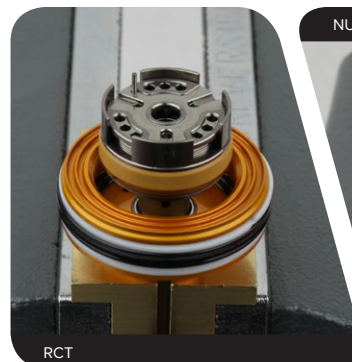

Align the guide pin on the piston with the guide hole in the RCT / NUDE Lock Piston Tool. Use your hand to start threading the lock piston on, then use a 24 mm open end wrench on the RCT / NUDE Lock Piston Tool to tighten the lock piston to 4.5 N-m (40 in-lb).

Apply pressure to the RCT / NUDE Lock Piston Tool when installing the lock piston to prevent the tool from slipping on the piston and damaging the guide pin.



NOTICE

Do not bend the guide pin. Bending or breaking the guide pin will damage the piston assembly.

20 RCT/NUDE: Apply a small amount of grease to the middle of the compression rod and below the top hat on the compression rod. Press on the top hat assembly nut to install the compression rod and top hat into the main piston assembly, then align the guide pin in the piston assembly with the guide pin hole in the top hat assembly.

NOTICE

Do not press the top hat assembly into the main piston assembly by the propellers as that can damage the propellers.

2019-2020 RL/RT: Apply a small amount of grease to the tip of the compression rod. Install the compression rod and top hat into the main piston assembly.

2018 RLR/RL/RT: Install the top hat spring and top hat washer onto the compression rod. Hold the compression rod vertically so the spring is seated in the groove inside the top hat.

NOTICE

If the top hat spring is not seated in the groove inside the top hat, the shock will not perform properly.

Apply a small amount of grease to the tip of the compression rod. Install the compression rod and top hat into the main piston assembly.

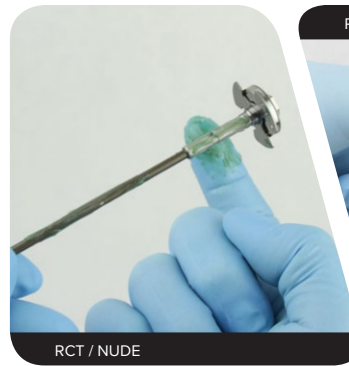

RCT / NUDE



RCT / NUDE

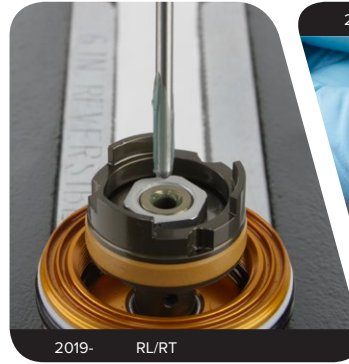

2019- RL/RT



2019- RL/RT

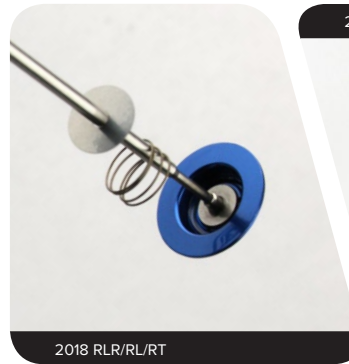

2018 RLR/RL/RT



2018 RLR/RL/RT



2018 RLR/RL/RT



2018 RLR/RL/RT

NOTICE

When replacing seals and o-rings, use your fingers or a pick to remove the seal or o-ring. Spray isopropyl alcohol on each part and clean with a shop towel. Apply grease to the new seal or o-ring. Only use RockShox Dynamic Seal Grease when servicing RockShox shocks.

To prevent damage to the shock use aluminium soft jaws and position the eyelet in the vise so that the adjustment knobs are clear of the vise jaws. For bearing mount shocks, wrap a shop towel around the eyelet, then clamp the eyelet flat into the vise.

Inspect each part for scratches. Do not scratch any sealing surfaces when servicing your suspension. Scratches can cause leaks.



- 1 Wrap a shop towel around the end of the damper body. Thread the air valve adapter tool into a shock pump. Thread the pump and adapter into the air fill port.

Pump air into the damper body to force the IFP out of the damper body, into the rag.



RockShox Air Valve Adapter Tool and shock pump

- 2 Spray isopropyl alcohol on the inside and outside of the damper body and clean it with a shop towel.

Remove a glove and use your finger to inspect the inside and outside of the damper body for scratches, dents, or other surface deformations. If any deformations are found, the damper body will need to be replaced.



- 3 Remove and replace the IFP o-ring. Apply RockShox Dynamic Seal Grease to the o-ring.



- 4 Install the IFP into the damper body with the stepped side visible. Use the Deluxe IFP Height Tool to push the IFP to the depth specified in the table below.

Measure the IFP depth from the lowest part of the IFP.

2020 RCT/NUDE; 2019-2020 RL/RT	
Shock Stroke	IFP insertion Depth
35 mm	49.5 mm
37.5-45 mm	58 mm
47.5-55 mm	66.5 mm
57.5-65 mm	75 mm

2018 RLR, RT3, RL, RT, R	
Shock Stroke	IFP insertion Depth
35 mm	48.1 mm
37.5 mm	50.2 mm
40 mm	52.3 mm
42.5 mm	54.5 mm
45 mm	56.6 mm
47.5 mm	58.7 mm
50 mm	60.8 mm
 50 mm*	67.2 mm
52.5 mm	62.9 mm
55 mm	65 mm
57.5 mm	67.2 mm
60 mm	69.3 mm
62.5 mm	71.4 mm
65 mm	73.5 mm

*Trek PowerFly



NOTICE

When replacing seals and o-rings, use your fingers or a pick to remove the seal or o-ring. Spray isopropyl alcohol on each part and clean with a shop towel. Apply grease to the new seal or o-ring. Only use RockShox Dynamic Seal Grease when servicing RockShox shocks.

To prevent damage to the shock use aluminium soft jaws and position the eyelet in the vise so that the adjustment knobs are clear of the vise jaws. For bearing mount shocks, wrap a shop towel around the eyelet, then clamp the eyelet flat into the vise.

Inspect each part for scratches. Do not scratch any sealing surfaces when servicing your suspension. Scratches can cause leaks.



- 1 Clamp the damper body into the RockShox Rear Shock Body Vise Block.

Tighten the vise firmly enough so that the IFP cannot move in the damper body. Check this by using your finger to push on the IFP.

If the IFP does move, use a shock pump to push out the IFP, and then reset it to the depth specified in the table.

Wrap a clean shop towel around the damper body.

Do not overtighten the vise so that the damper body gets crushed.

NOTICE

The RockShox Rear Shock Body Vise Block holds the IFP in place. Failure to use the vise block when clamping the damper body into the vise may result in improper IFP height. Improper IFP height can cause the damper to fail.



- 2 Pour new Maxima PLUSH 7wt Suspension Oil into the damper body until it is level with the top.

Maxima PLUSH 7wt Suspension Oil is backwards compatible with RockShox 7wt suspension oil.

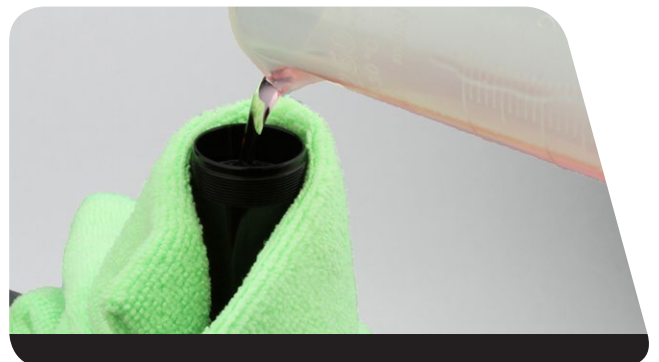

- 3** Check that the rebound adjuster knob is set to the fastest rebound setting. Rotate the rebound adjuster counter-clockwise until it stops. Slide the seal head/air piston until it stops at the end of the damper shaft.



- 4** Use your hand to install the seal head/air piston onto the damper body.
- Do not hold on to the shaft eyelet or damper shaft while inserting the seal head. It will move the piston/shaft assembly, causing too much fluid to displace out of the damper body.**
- Check that the compression ball is removed from the seal head/air piston.**
- Fluid will be displaced out of the bleed port.*

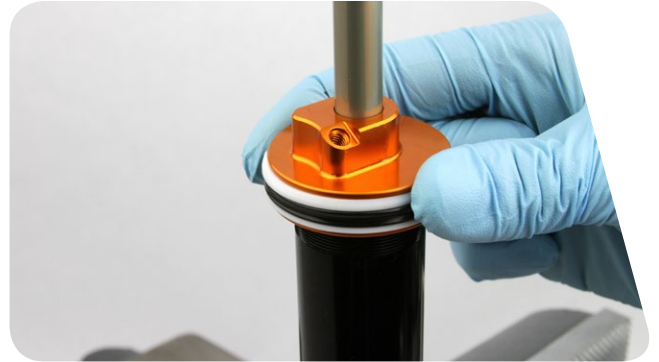

- 5** Use a torque wrench with 17 mm crowfoot to tighten the seal head/air piston to 28 N·m (248 in-lb).
- Install the crowfoot onto the torque wrench at a 90° angle to the handle to ensure an accurate torque reading.**



- 6** Allow air bubbles to escape from the bleed port in the seal head. Insert the new compression ball into the bleed port.



- 7 Use a 2 mm hex wrench to thread the bleed screw into the bleed port until you feel it touch the compression ball, then tighten the bleed screw an additional ½ turn.

NOTICE

Overtightening the bleed screw can damage the compression ball.



- 8 Use a shock pump with the air valve adapter tool to pressurize the damper body to the correct psi for your shock:

Model	Pressure
RCT	400 psi
RT3	350 psi
NUDE/RLR; 2018 RL/RT	500 psi
2019 RL/RT	420 psi
R	250 psi

If you have the proper fill equipment, you may substitute air with nitrogen.

Once you have pressurized the shock, remove the air valve adapter tool from the air fill port before removing it from the shock pump. Separating the pump from the adapter first will cause all of the air to escape from the shock.



- 9 Use a Schrader valve tool to install the damper air/nitrogen fill port cap.



- 10 Remove the shock from the vise.
Spray the damper assembly with isopropyl alcohol and clean it with a shop towel.

The remote spring can be serviced on its own without completing air can or damper service.

- 1 Use a vise block with the 10 mm shaft clamp to clamp the shaft into a vise.

NOTICE

To prevent damage to the seal head/air piston, position the shaft in the vise so that the piston is clear of the vise jaws.



- 2 While holding the spring preloader in place, remove the preloader lock screw from the eyelet.
Remove the spring preloader, spring bushing, and remote spring from the eyelet.

CAUTION - EYE HAZARD

The preloader lock screw is spring loaded and can eject rapidly from the eyelet if the spring preloader is not held in place.



- 3** Apply a thick layer of grease to the inside and outside of a new remote spring, then install the spring into the eyelet with the spring tang in the spring tang hole.



- 4** Install a new bushing into the eyelet, with the grooved edge facing out of the eyelet.



5 Install the spring preloader so that the spring tang slides into the spring tang hole in the preloader.

Use a 3 mm hex wrench to preload the spring counter-clockwise until the notch in the spring preloader lines up with the set screw hole, then tighten the set screw to 0.8 N·m (7 in-lb)

Use a T25 TORX wrench to test the spring tension.

NOTICE

The spring preloader must be rotated counter-clockwise to preload the spring.



NOTICE

When replacing seals and o-rings, use your fingers or a pick to remove the seal or o-ring. Spray isopropyl alcohol on each part and clean with a shop towel. Apply grease to the new seal or o-ring. Only use RockShox Dynamic Seal Grease when servicing RockShox shocks.

To prevent damage to the shock use aluminium soft jaws and position the eyelet in the vise so that the adjustment knobs are clear of the vise jaws. For bearing mount shocks, wrap a shop towel around the eyelet, then clamp the eyelet flat into the vise.

Inspect each part for scratches. Do not scratch any sealing surfaces when servicing your suspension. Scratches can cause leaks.



- 1** Clamp the shaft eyelet in the vise with soft jaws.

Install the Counter Measure onto the damper body. Apply RockShox Dynamic Seal Grease to the seal head/air piston seals.



- 2** Inject 1 mL of Maxima Extra 15w50 Suspension Oil into the air can before installing the air can onto the damper. Firmly press the air can down until the sealhead/air piston is inserted into the air can.

⚠ CAUTION- EYE HAZARD

Fluid will eject out of the holes as you install the air can onto the damper. Wear safety glasses.



- 3** Remove the shock from the vise, turn it over and clamp the damper body eyelet in the soft jaws.

Inject another 1 mL of Maxima Extra 15w50 Suspension Oil into the air can.



- 4** Clamp the air shaft eyelet into the vise. Press the air can onto the damper then thread it onto the shaft eyelet until it is hand tight.

Spray isopropyl alcohol on the outside of the air can and clean it with a shop towel.



- 5** Remove the shock from the vise. Turn it over and clamp the damper body eyelet in the vise.

Stabilize the air can with a strap wrench to prevent it from rotating. Use a torque wrench with a 13 mm crowfoot to tighten the air can to 4.5 N·m (40 in-lb).



- 6** Remove the shock from the vise. Spray isopropyl alcohol on the shock and clean it with a shop towel.

- 7** Install the sag indicator o-ring.



Eyelet Bushing Installation

- 1 Apply a light layer of grease to the outside of the new bushing.

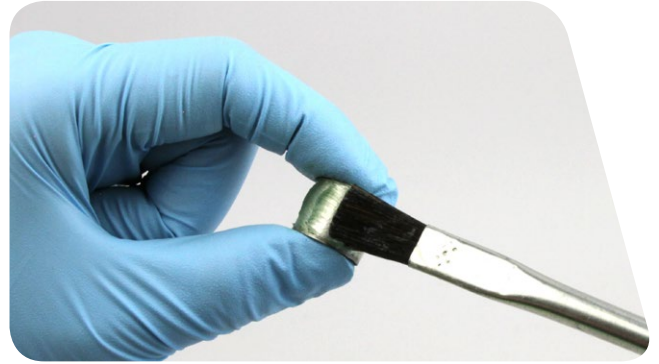

- 2 Position the shaft eyelet and eyelet bushing between the soft jaws of a vise. Slowly turn the vise handle to begin pressing the eyelet bushing into the shaft eyelet.

Check the alignment of the bushing as it enters the eyelet. If the bushing starts to enter the eyelet at an angle, remove the bushing from the eyelet, regrease the bushing, and repeat this step until the bushing enters the eyelet straight.

Continue to press the eyelet bushing until it is seated in the shaft eyelet.

Remove the shock from the vise and repeat the installation process for the other bushing and eyelet.



Mounting Hardware Installation

Some mounting hardware is easily installed using only your fingers. Press the bushing pin into the shock eyelet bushing until the pin protrudes from both sides of the eyelet an equal amount. Next, press an end spacer, large diameter side first, onto each end of the bushing pin. If this works, you have completed mounting hardware and bushing service.

If you are unable to install your mounting hardware using your fingers, use the RockShox rear shock bushing removal/installation tool.

- 1 Thread the small end of the push pin onto the threaded rod until the push pin is flush or slightly protrudes from the hex-shaped end of the push pin.



- 2 Insert the threaded rod through the bushing pin then through the shaft eyelet so that the bushing pin is positioned between the push pin and the eyelet.



- 3 Thread the large, open end of the catcher onto the rod until it rests on the eyelet.



- 4 Clamp the catcher in a vise or hold it secure with a 13 mm wrench. Use a second 13 mm wrench to thread the push pin along the rod until it pushes the bushing pin into the shock eyelet bushing.

Continue to thread the push pin until the bushing pin protrudes from both sides of the eyelet an equal amount.

You may need to unthread the catcher slightly to check the bushing pin spacing.



13 mm

- 5** Press an end spacer, large diameter side first, onto each end of the bushing pin.



- 6** Reinstall the shock to your bicycle frame according to the bicycle manufacturer's instructions.

- 7** Use a shock pump to pressurize the shock to the recorded air pressure plus 20%. After adding air to the shock, the pressure will need to be equalized between the shock chambers.

Record the air pressure value on the pump, then unthread it from the shock. Slowly but firmly press or sit on the saddle to compress the shock until there is a hissing sound. This sound indicates air transfer between chambers.

Reinstall the pump and pressurize the shock to the desired air pressure. Record the air pressure, then unthread it from the shock. Repeat this process until you reach the desired amount of sag, then install the valve cap.

NOTICE

When pressurizing the shock, do not exceed maximum pressure rating.

The pump must be removed from the shock prior to checking sag to avoid damage to the pump.

This concludes the service for the RockShox Deluxe rear shock.

Remote Cable and Housing Installation - RLR/Ultimate Remote

To install new cable and housing into the OneLoc remote, consult the OneLoc Remote User Manual on www.sram.com/service.

Parts, Tools, and Supplies

Parts

- Deluxe Remote Service Kit - 200 hours
- Deluxe Remote Spring Service Kit
- Shift cable and housing

Safety and Protection Supplies

- Safety glasses
- Nitrile gloves

Common Tools

- 2 mm hex wrench
- 2 mm hex bit socket
- T25 TORX wrench
- 5 mm open end wrench
- Torque wrench
- Cable and housing cutters

Remote Cable and Housing Installation

- 1 After the housing has been routed and installed on the bicycle, use a 5 mm open end wrench to thread a new ferrule onto the housing.
Do not push the housing into the ferrule.



- 2 Install the ferrule and housing into the reservoir, then use a 2 mm hex bit socket to tighten the ferrule lock screw to 0.9 N-m (8 in-lb).



- 3 Thread the cable through the housing, spool, and under the cable set screw. Pull the cable tight and use a torque wrench with a 2 mm hex bit socket to tighten the cable set screw to 0.9 N-m (8 in-lb).



- 4** Use cable and housing cutters to trim the cable, then install an end cap.
Tuck the cable into the pocket.



- 5** Install the spool cap, then use a torque wrench with a T25 TORX bit socket to tighten the spool cap to 0.9 N-m (8 in-lb).



These are registered trademarks of SRAM, LLC:

1:1®, Accuwatt®, Avid®, Bar®, Blackbox®, BoXXer®, DoubleTap®, Elita®, eTap®, Firecrest®, Firex®, Grip Shift®, GXP®, Hammerschmidt®, Holzfelder®, Hussefelt®, i-Motion®, Judy®, Know Your Powers®, NSW®, Omnium®, Pike®, PowerLock®, Quarq®, Qollector®, RacerMate®, Reba®, Rock Shox®, Ruktion®, Service Course®, ShockWiz®, SID®, Single Digit®, Speed Dial®, Speed Weaponry®, Spinscan®, SRAM®, SRAM APEX®, SRAM EAGLE®, SRAM FORCE®, SRAM RED®, SRAM RIVAL®, SRAM VIA®, Stylo®, Torpedo®, The Power of Bicycles®, Truvativ®, Varicrank®, Velotron®, World Bicycle Relief®, X0®, X01®, X-SYNC®, XX1®, Zed tech®, ZIPP®

These are registered logos of SRAM, LLC:



These are trademarks of SRAM, LLC:

10K™, 1X™, 202™, 30™, 302™, 303™, 404™, 454™, 808™, 858™, ABLC™, AeroGlide™, AeroBalance™, AeroLink™, Airea™, Air Guides™, AKA™, AL-7050-TV™, Automatic Drive™, Automatix™, AxCad™, Axial Clutch™, AXS™, BB5™, BB7™, BB30™, Bleeding Edge™, Blipbox™, BlipClamp™, BlipGrip™, Blips™, Bluto™, Bottomless Tokens™, Cage Lock™, Carbon Bridge™, Centera™, Charger 2™, Charger™, Clickbox Technology™, Clics™, Code™, Cognition™, Connectamajig™, Counter Measure™, DD3™, DD3 Pulse™, DebonAir™, Deluxe™, Deluxe Re:Aktiv™, Descendant™, DFour™, DFour91™, Dig Valve™, DirectLink™, Direct Route™, DOT 5.1™, Double Decker™, Double Time™, Dual Flow Adjust™, Dual Position Air™, DUB™, DZero™, E300™, E400™, Eagle™, E-Connect4™, E-matic™, ErgoBlade™, ErgoDynamics™, ESP™, EX1™, Exact Actuation™, Exogram™, Flow Link™, FR-5™, Full Pin™, Guide™, GX™, Hard Chrome™, Hexfin™, HollowPin™, Howitzer™, HRD™, Hybrid Drive™, Hyperfoil™, i-3™, Impress™, Jaws™, Jet™, Kage™, Komfy™, Level™, Lyrik™, MatchMaker™, Maxle™, Maxle 360™, Maxle DH™, Maxle Lite™, Maxle Lite DH™, Maxle Stealth™, Maxle Ultimate™, Micro Gear System™, Mini Block™, Mini Cluster™, Monarch™, Motion Control™, Motion Control DNA™, MRX™, Noir™, NX™, OCT™, OmniCal™, OneLoc™, Paragon™, PC-1031™, PC-1110™, PC-1170™, PG-1130™, PG-1050™, PG-1170™, Piggyback™, Poploc™, Power Balance™, Power Bulge™, PowerChain™, PowerDomeX™, Powered by SRAM™, PowerGlide™, PowerLink™, Power Pack™, Power Spline™, Predictive Steering™, Pressfit™, Pressfit 30™, Prime™, Qalvin™, R2C™, RAIL™, Rapid Recovery™, Re:Aktiv ThruShaft™, Recon™, Reverb™, Revelation™, Riken™, Rise™, ROAM™, Roller Bearing Clutch™, RS-1™, Sag Gradients™, Sawtooth™, SCT - Smart Coasterbrake Technology, Seeker™, Sektor™, SHIFT™, ShiftGuide™, Shorty™, Showstopper™, Side Swap™, Signal Gear Technology™, SL™, SL-70™, SL-70 Aero™, SL-70 Ergo™, SL-80™, SL-88™, SLC2™, SL SPEED™, SL Sprint™, Smart Connect™, Solo Air™, Solo Spoke™, SpeedBall™, Speed Metal™, SRAM APEX 1™, SRAM Force 1™, SRAM RIVAL 1™, S-series™, Stealth-a-majig™, StealthRing™, Super-9™, Supercork™, Super Deluxe™, Super Deluxe Coil™, SwingLink™, TaperCore™, Timing Port Closure™, Tool-free Reach Adjust™, Top Loading Pads™, Torque Caps™, TRX™, Turnkey™, TwistLoc™, Tyrewiz™, VCLC™, Vivid™, Vivid Air™, Vuka Aero™, Vuka Alumina™, VukaBull™, Vuka Clip™, Vuka Fit™, Wide Angle™, WiFLi™, X1™, X5™, X7™, X9™, X-Actuation™, XC™, X-Dome™, XD™, XD Driver Body™, XDR™, XG-1150™, XG-1175™, XG-1180™, XG-1190™, X-Glide™, X-GlideR™, X-Horizon™, XLoc Sprint™, XX™, Yari™, Zero Loss™



Specifications and colors subject to change without prior notice.
© 2019 SRAM, LLC

This publication includes trademarks and registered trademarks of the following companies:

Loctite and 242 are registered trademarks of Henkel Corporation
Maxima Racing Oils® is a registered trademark of Maxima Racing Oils
PLUSH™ and Extra™ are trademarks owned by Maxima Racing Oils
TORX® is a registered trademark of Acument Intellectual Properties, LLC
Trek and Powerfly are registered trademarks of Trek Bicycle Corporation



ASIAN HEADQUARTERS

SRAM Taiwan
No. 1598-8 Chung Shan Road
Shen Kang Hsiang, Taichung City
Taiwan R.O.C.

WORLD HEADQUARTERS

SRAM LLC
1000 W. Fulton Market, 4th Floor
Chicago, Illinois 60607
U.S.A.

EUROPEAN HEADQUARTERS

SRAM Europe
Paasbosweg 14-16
3862ZS Nijkerk
The Netherlands