



# 2019 MACS Training

By: Ross Koehler  
February 21, 2019



- Overview of Bergstrom's No-Idle Systems (NITE) in the Market Today
- Troubleshooting the Latest Generation NITE Systems
- Preventative Maintenance



OVERVIEW  
OF THE NITE<sup>®</sup> SYSTEMS  
IN THE MARKET TODAY

# NORTH AMERICA INTEGRATED PARKED HVAC

DAIMLER

FREIGHTLINER

WESTERN STAR



ParkSmart and RestStar

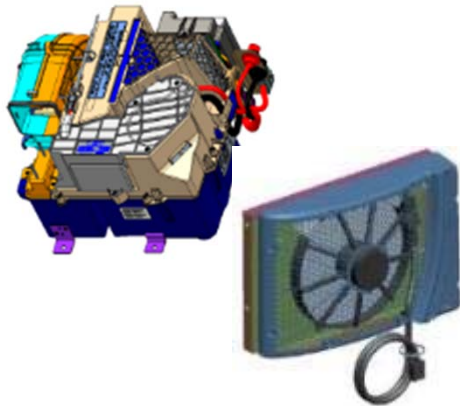

Parking Cooler

KENWORTH

Peterbilt

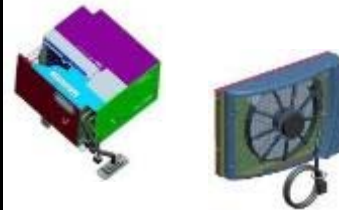

KIMS and SmartAir

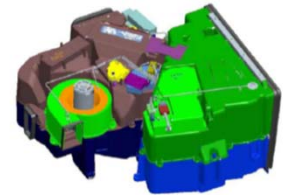

Navistar  
No-Idle  
System



# NEW CASCADIA BATTERY-POWERED HVAC SYSTEM (BPHS)

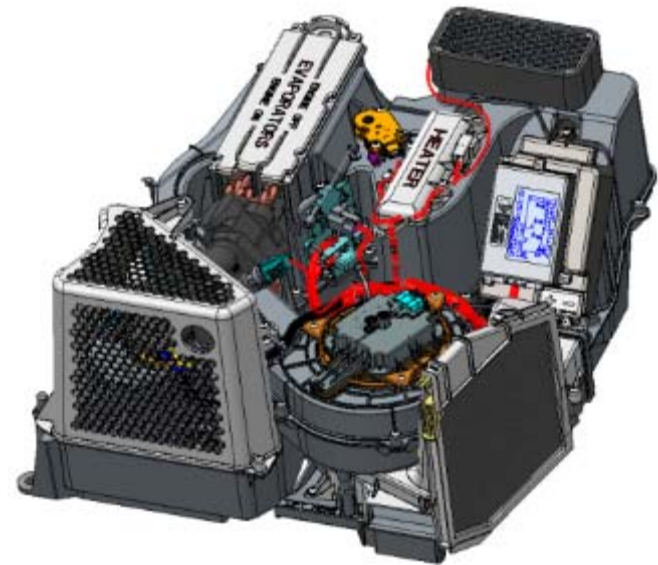

# NEW CASCADIA BPHS MODULE

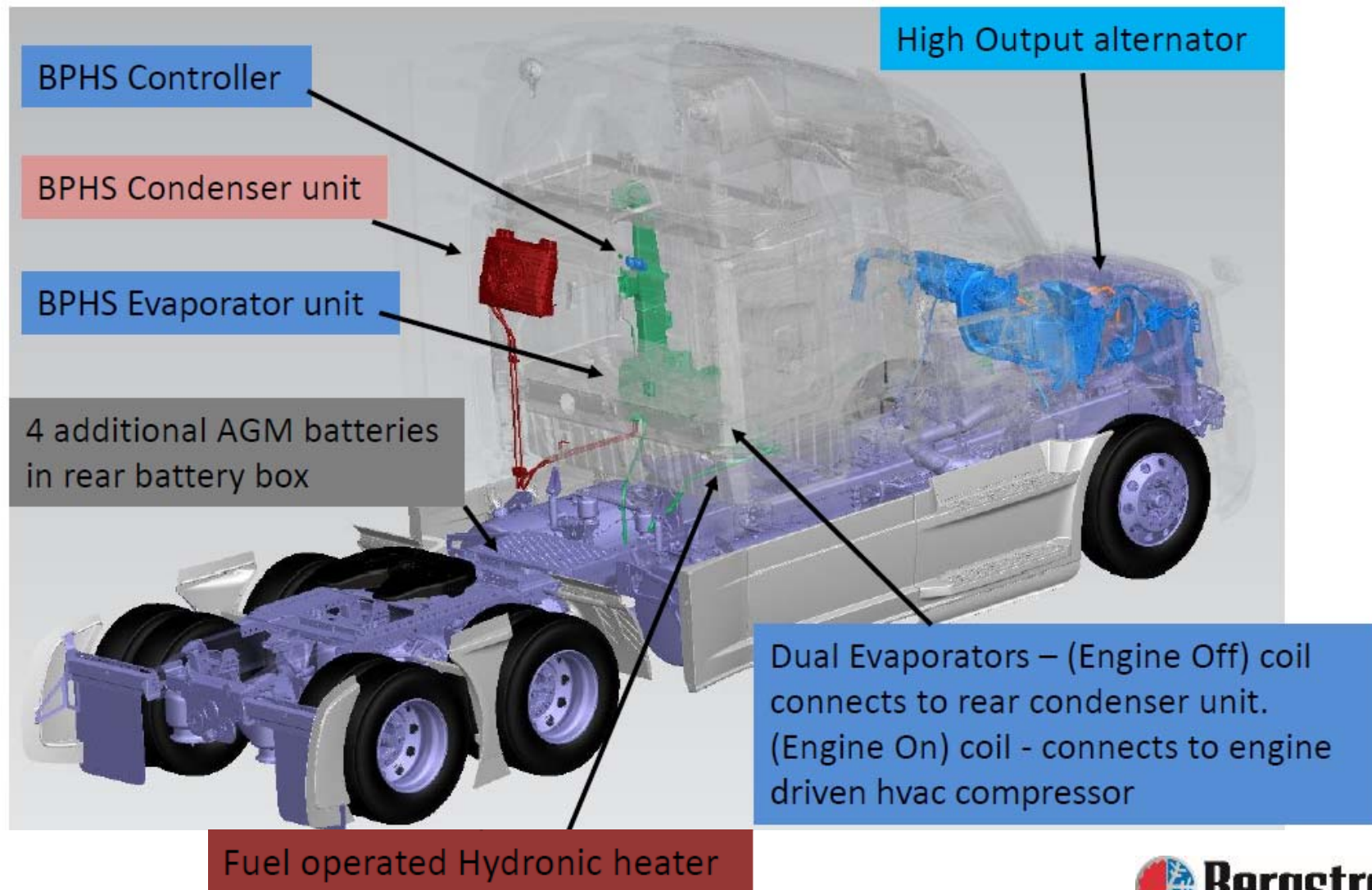

# BERGSTROM NO-IDLE HVAC SYSTEM DESCRIPTIONS

The screenshot shows the Bergstrom website's 'Factory-Installed Systems' page. The navigation bar includes 'Home', 'NITE No-Idle', 'Off-Highway', 'HVAC Parts', 'About Us', 'Home', 'Facilities', and 'Contact'. The left sidebar lists various services like 'NITE No-Idle', 'NITE Priority', 'NITE SS', 'Factory-Installed Systems', 'NITE Applications', 'Manual & Support', 'NITE Accessories', 'Estimates & Orders', 'Inverters', 'Trucks', 'Calculate Savings', 'Warranty', 'Weight Conversion', 'Distributors/Service Centers', 'Independent List', 'NITE Service Parts List', 'Contact NITE Sales', and 'Financing'. The main content area is titled 'Bergstrom's Factory-Installed No-Idle Systems' and features a search bar. Below the title, there is a paragraph explaining the partnership with heavy-duty truck companies. The page lists several OEM systems: Freightliner OEM Systems (ParkSmart), Cascadia BPHS, Kenworth OEM System (KIMS), Navistar OEM No-Idle System (MaxiPower™), Pylferbilt OEM System (SmartAir™), Western Star OEM System (RestStar™), and Volvo OEM System (Volvo Parking Cooler System). Each system entry includes a brief description and links to technical guides and videos.

Complete description of all the Bergstrom parking cooler systems can be found online at the following URL:

<https://us.bergstrominc.com/nite-oe-systems/>



# NO-IDLE NITE SYSTEMS AVAILABLE FOR AFTERMARKET INSTALLATION



**NITE® Phoenix**  
introduced 2010  
(3<sup>rd</sup> Generation)



**NITE® SSI**  
introduced 2017  
Split System





# NITE PHOENIX AND SSI SYSTEMS

- Automatic Digital Temperature Control. For optimum comfort at your fingertips providing service diagnostics, automatic temperature control and more.
- Electrified A/C unit. Runs on 4 auxiliary AGM / deep-cycle batteries.
- System runs 8-10 hours
- Installs easily under bunk
- Installation kits available for all North America class 8 trucks
- Available with wireless controller and app

# SSI CONDENSER / EVAPORATOR SPLIT



Durable condenser  
mounts on the back  
wall of a sleeper



Evaporator mounts  
under the bunk

# SSI PLASTIC HOUSING

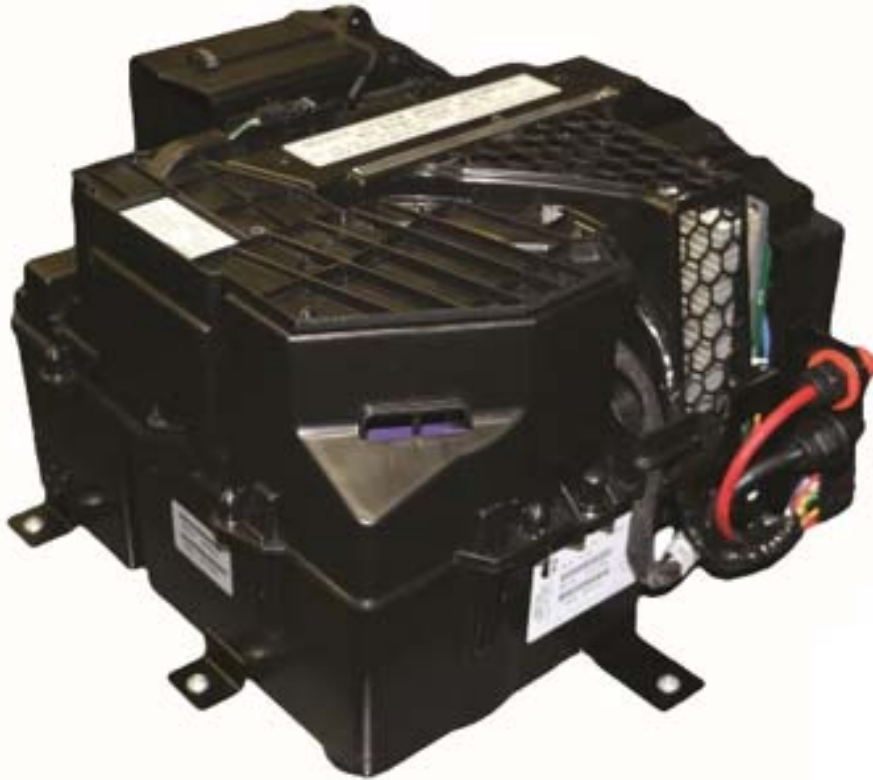

Evaporator  
assembly housing  
is made out of  
20% TFPP.



# **TROUBLESHOOTING LATEST GENERATION NITE SYSTEMS**

# TROUBLESHOOTING SSI NEW FEATURES

## Refrigerant Pressure Switch (Binary)

- This normally closed pressure switch will open for low or high / high side pressure and prevent the operation of the compressor.

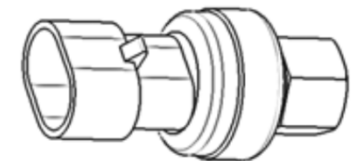

### SOLUTION

- The Schrader mounted switch is serviceable. It opens on low or high – high side pressure.
- If pressure switch is open or user interface shows a fault, you must connect to the refrigerant loop and check system pressure.

# TROUBLESHOOTING SSI NEW FEATURES (CONT.)

## 12VDC Brushless Blower Motor

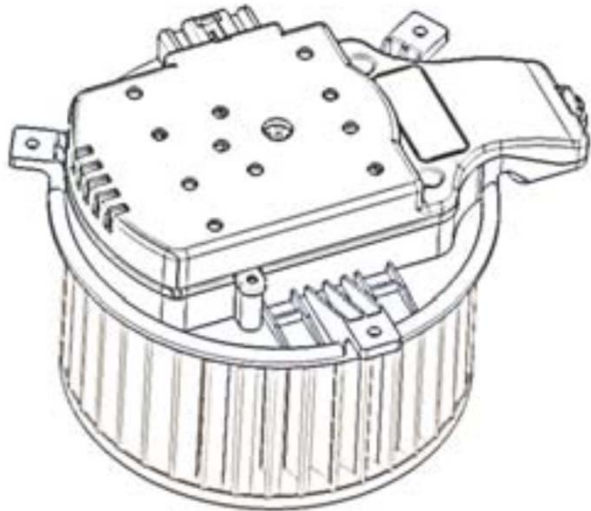

- First do a visual inspection of all the blower parts.
- You should have 12 volts at pin 5 (pos), if you do not, check fuse F3.
- If you have 12 volts main power, turn the unit on and check for the speed signal voltage at blower pin 4 coming from the system controller pin 20.
  - You should have approximately 6.3V for speed 1, approximately 5.0V for speed 2 and approx. 2.8V for speed 3. If all of these voltages are correct and the fan does not run, it is defective, and needs to be replaced.
- Using a DC ammeter, you can check the amperage draw of the blower. Normal amps will range from 4 to 10 amps.

# TROUBLESHOOTING SSI NEW FEATURES (CONT.)

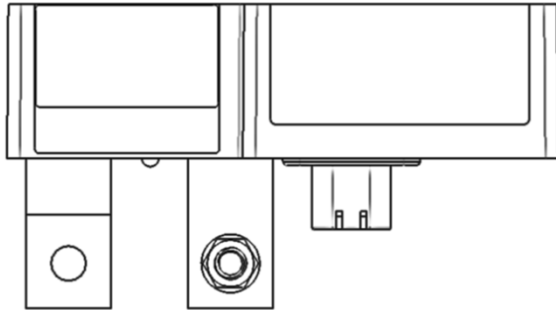

- The BMS monitors the auxiliary batteries for the state of charge, communicates with the NITE SSI system, and controls the battery separator solenoid.
- The LED light on the BMS blinks approximately once every 60 seconds and indicates power to the device but does not provide diagnostics.
- Power inputs to the BMS are fuse protected.

# SSI NEW SERVICEABLE COMPONENTS

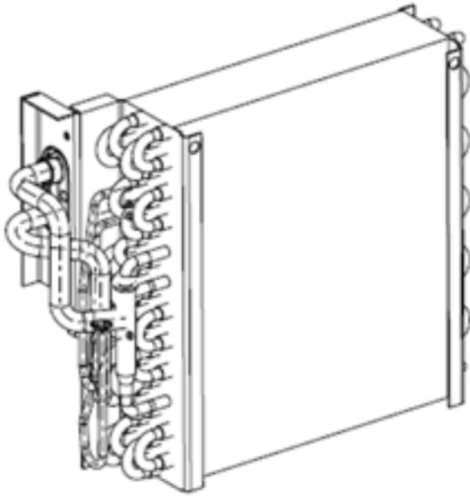

Evaporator

To service the seals, drier, coils or lines on the NITE SSI system you must follow Section 609 procedures to reclaim refrigerant and recharge the system to the amount specified in the manual.



Receiver Drier (in remote condenser)

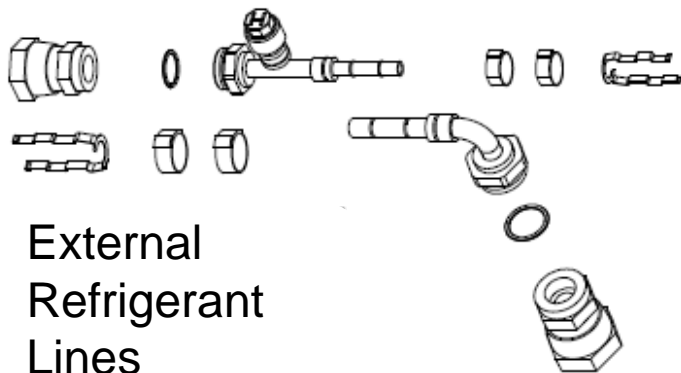

External Refrigerant Lines



TXV

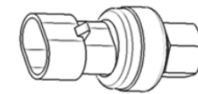

Binary Switch



# NITE SSI App

## NITE App Features & Benefits

All the SSI controllers come with wireless technology and can be used with the NITE App.

- **Control.** Take full command with your mobile device. Turn system on/off, set temperature and control the fan speed.
- **Monitoring.** Get immediate access to battery information, efficiency status and run time calculator.
- **Troubleshooting.** Take control of any issues with immediate diagnostics, system information and operational guides.



# NITE App



**If location services are enabled on the device,** selecting "Find a dealer" will bring up a map showing the Aftermarket NITE dealer locations in the United States and Canada. This list may not include all OEM dealerships that service Nite products. This list can change without notice.

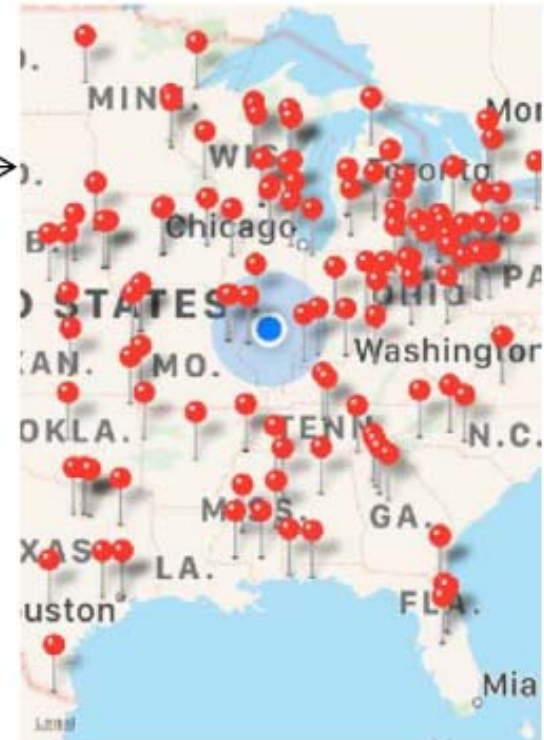

# NITE App

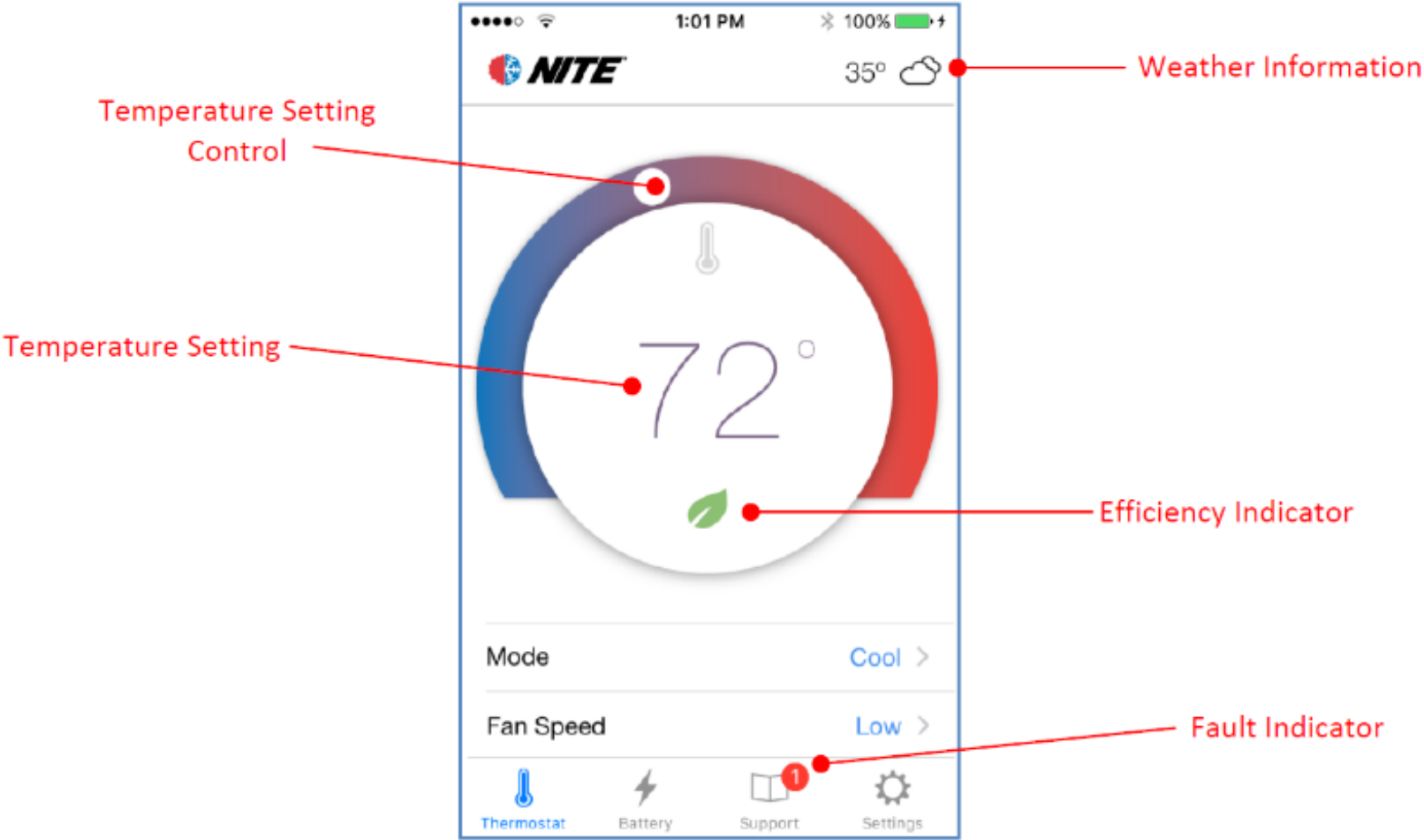

# NITE App

This screen displays the information broadcast by the Battery Monitoring System (BMS) over the CAN communication bus.

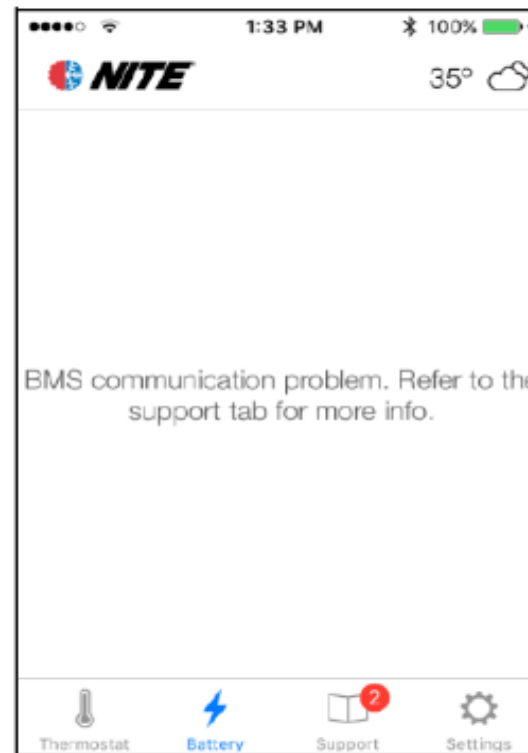
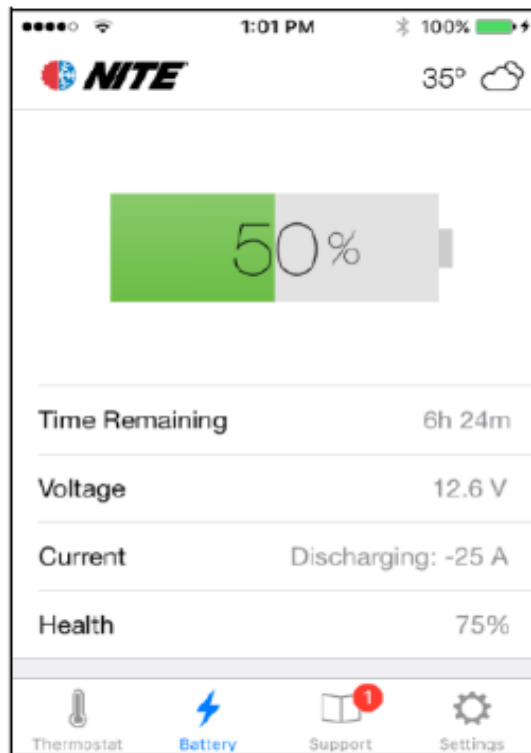

Information Displayed:  
- Aux Batteries State of Charge

# RECOMMENDED NITE SYSTEM BATTERIES

- The batteries for a Bergstrom No-Idle system should be 4 AGM deep cycle batteries with a 100AH (amp hour) rating or equivalent.
  - Bergstrom recommends Trojan or NorthStar batteries
  - Low cost, lesser quality AGM batteries or the use of wet cell batteries for replacements in service have resulted in performance complaints in the field
- Never mix lead acid and AGM within the same bank. An auxiliary battery bank must always have 4 AGM batteries. To meet advertised run time, NITE systems require a battery bank with minimum combined amp hour ratings of 400.





**PREVENTATIVE  
MAINTENANCE**

# PREVENTATIVE MAINTENANCE

(Recommended Every Spring and Every 25,000 miles in the Summer)

## Proper Air Filter Maintenance:

- NITE systems are 100% recirculation (no fresh air)
  - Clogged evaporator filter from animal hair, lint, and other debris in the air inside the cab must be prevented.
  - Continued operation with a clogged filter may result in poor performance and potential evaporator failure.



# PREVENTATIVE MAINTENANCE

(Recommended Every Spring and Every 25,000 miles in the Summer)

Bergstrom No-Idle systems that are equipped with the system controller shown have a filter indicator.

- When necessary, the check filter indicator will notify you that the filter must be cleaned or changed.
- To reset the check filter indicator: at screen 1, press and hold enter button for 3 seconds.





# PREVENTATIVE MAINTENANCE

(Recommended Every Spring and Every 25,000 miles in the Summer)

- Inspect the recirculation grill (where applicable).
- This grille is installed on the bunk support wall.
- The cool air from the vehicle interior must flow freely back to the NITE system.
- *Warning:* Do not block the recirculation grille with personal items, clothes, etc. as this will reduce the performance of the system.



# PREVENTATIVE MAINTENANCE

(Recommended Every Spring and Every 25,000 miles in the Summer)

- Inspect the rubber drip tube attached to the NITE system (outside and underneath the truck floor).
- If the drip tube is missing, cracked, or showing signs of deterioration, it is recommended to have it replaced.
- Make sure the drip tube is clean and open.
- When re-attaching the tube to the unit, make sure it is firmly seated.

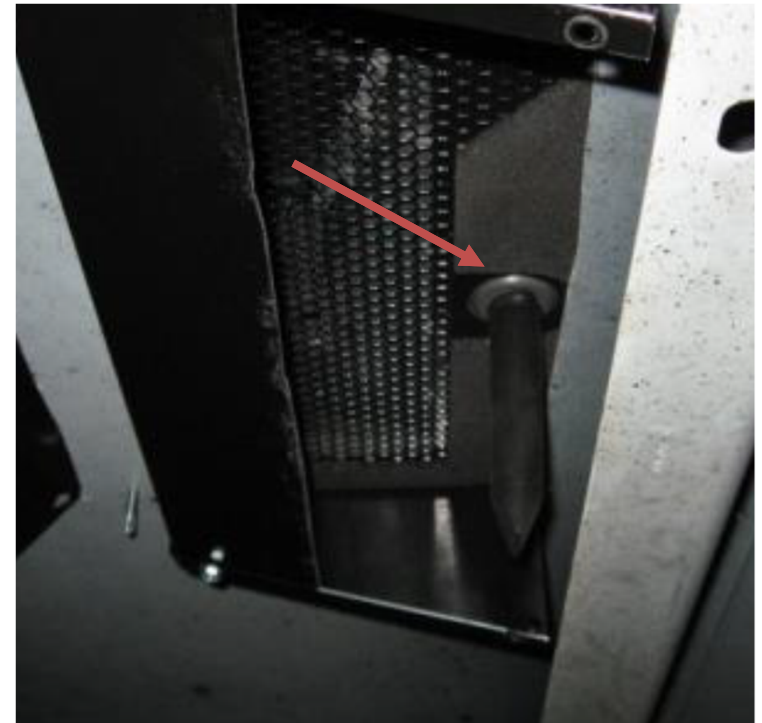

# PREVENTATIVE MAINTENANCE

(Recommended Every Spring and Every 25,000 miles in the Summer)

A plugged or dirty condenser can cause high pressure in the system resulting in reduced performance and run time of the system.

- It is recommended to use a core cleaner that is non caustic, detergent-based alkaline coil cleaner, biodegradable, and releases no VOCs (Volatile Organic Compounds).
- If a core cleaner is not available, low pressure water can also be used.



# SSI Preventative Maintenance

## (Recommended Every Spring and Fall)

**\*\*\*The leading issue for service calls we receive on our NITE technical support line is related to batteries and connections.\*\*\***

### **Batteries and connections:**

- Check the auxiliary bank of batteries. Ideally batteries should be identical in make and model.
- Visually inspect the batteries for leakage, swelling, and corrosion. Replace any damaged batteries, as needed.
- Inspect all electrical connections, including all battery and separator posts. When necessary, remove, clean and retighten. Initial installs use tin-plated, heavy-duty battery lugs to help prevent loose connections, damage and corrosion.
- We recommend replacing any damaged or light duty lugs with the correct Bergstrom supplied lugs.



# SSI Preventative Maintenance

## (Recommended Every Spring and Fall)

### Batteries and connections (cont.):

- Apply dielectric grease to all battery connections.
- Check the Battery Management System (BMS) where applicable.
  - Make sure the cork gasket is installed on the bottom of the BMS and supports the device to prevent any vibration and/or movement.
  - Failure to install the gasket or installing the BMS unsupported may cause damage and void the warranty policy.
- Check battery box and battery hold-down brackets.
- Inspect all items for wear or damage.
- Retighten all hardware to prevent box and batteries from moving.
- If your system is equipped with a BMS, check the state of health on the batteries.

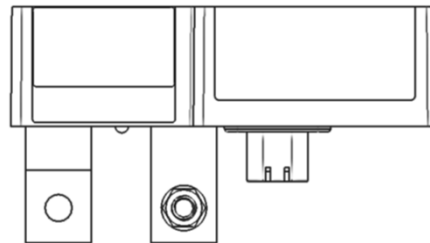

# SSI Preventative Maintenance

## Leak Detection

- When a vehicle comes in for service and you suspect a leak, perform a good visual inspection to assure there are no obvious leaks, such as leaking connections and missing caps on the service ports.
- All NITE units contain refrigerant dye, so leaks should be visible with a blue light leak detection flashlight and fluorescent-enhancing glasses.
- All NITE systems use PVE oil and 134a refrigerant for the electric side of the system.



# SSI Preventative Maintenance

## Leak Detection (cont.)

- The system should never be recovered to check AC charge.
- NITE systems do not need any oil added unless refrigerant loop components have been replaced, or the system has been recovered in excess of 4 times (check service history).
- Addition of improper oil types, or too much oil, will cause damage to the compressor.



# Preventative Maintenance

The following NITE systems now have a serviceable receiver drier:

- Volvo Parking Cooler
- ParkSmart
- BPHS
- SSI

If the refrigerant charge is pulled out of the NITE systems listed above, it is recommended to replace the receiver drier prior to re-charging the system (refer to the NITE manuals for proper instructions).





# Online Resource for NITE Replacement Parts

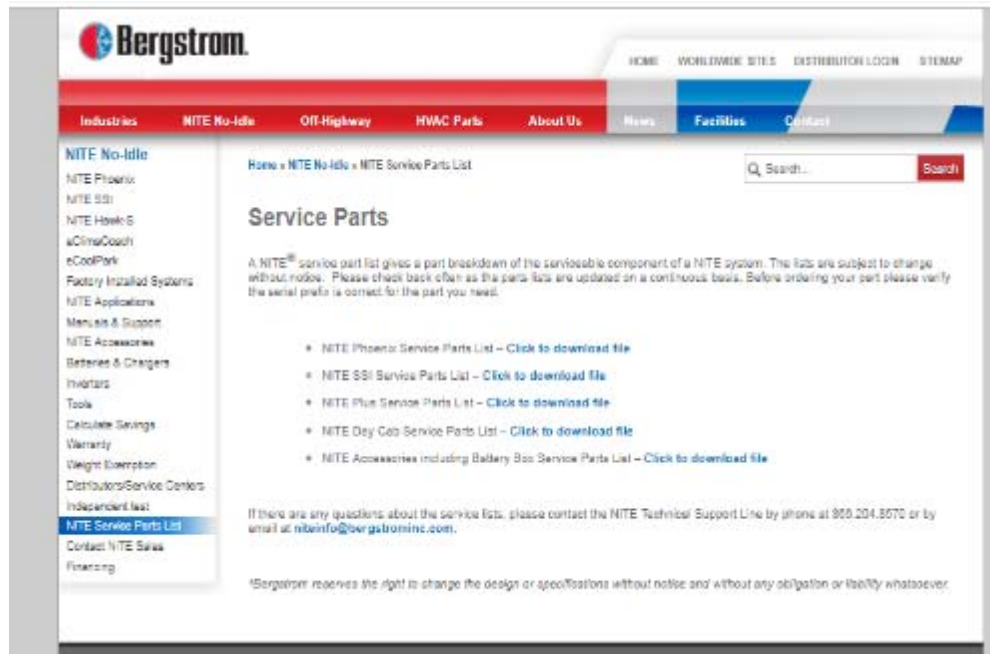

Bergstrom has NITE® service parts lists that give a breakdown of the serviceable components for each NITE system.

The lists are updated on a continuous basis and are subject to change without notice so it is important to check back often.

<https://us.bergstrominc.com/nite-service-parts/>





# NITE TECHNICAL SUPPORT

For any questions or technical support for your NITE system, call our technical support team Monday through Friday from 7:30am to 4:00pm CST at **1-866-204-8570**.



**Questions?  
Thank you.**

**VISIT US AT THE TRADE SHOW.  
BOOTHS 327 and 426**