



2019

Filter Guide



GUÍA DE FILTROS • GUIDE DE FILTRES

Includes Complete Cabin Air Filter Guide with Instructions

WHY VALVOLINE™ FILTERS?

For over 150 years, Valvoline™ has been providing the best quality automotive products to you and your customers. We serve more than 100 countries worldwide and continue to be a leading marketer, distributor and producer of quality branded automotive and industrial products and services.

Valvoline filters follow the same standard of excellence that is seen throughout Valvoline's product portfolio. Our filter program provides you with quality products and excellent service.



BENEFITS OF VALVOLINE BRANDED FILTER

- Guaranteed Quality*
- Product Warranty*
- Technical Hotline Support
- Local Distribution
- Direct-To-Installer Shipment Program for Slower Moving Filters
- Brand Recognition
- Multi-Fit Filter Design For Reduced Inventory
- Filter App With VIN Part Finder Functionality
- Filter Site For Application Data
- Industry-Leading Product Catalog

ALL VALVOLINE FILTERS MEET OR EXCEED OE SPECS

VALVOLINE OIL FILTER

An oil filter is essential to providing a vehicle's engine with clean, lifesaving lubricating oil. While engine oil keeps the moving parts in an engine lubricated, the oil filter stops harmful dirt and contaminants from circulating in the oil system, which can cause premature wear and costly repairs. The oil filter not only traps these particles, but it contains them, ensuring a continuous and clean oil flow to your engine.

VALVOLINE FILTER DESIGN

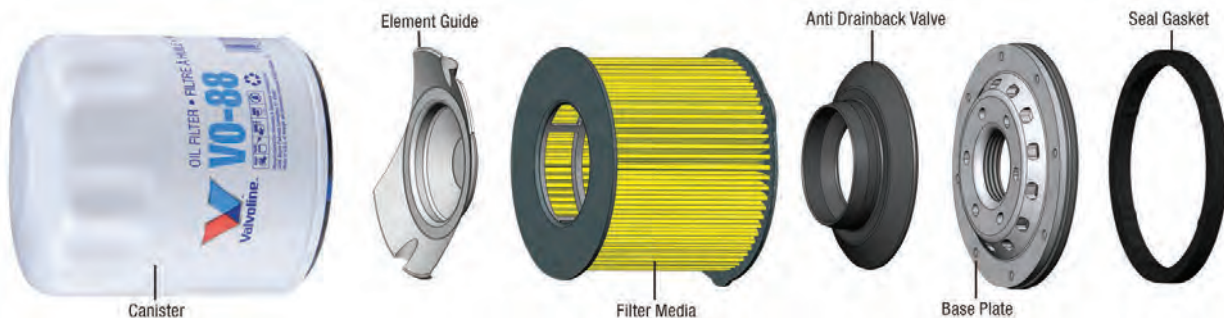

*VO-88 used for illustration purposes. Not all filters match this design.

Supersedes All Previously Printed Material, Including 2018 Filter Guide

Sustituye todo el material impreso anteriormente, incluyendo la guía de filtros 2018

Remplace toute documentation imprimée précédente, y compris le Guide des filtres de 2018

Limited Warranty*

Valvoline filters are warranted to be free from manufacturer's defects in material, workmanship or design. Valvoline filters are to be used in accordance to the engine manufacturer's recommendations. Valvoline filters meet OE recommended drain intervals regardless of make, model, or year of the vehicle. Valvoline guarantees workmanship on all of its filters.

*See inside back cover for complete warranty information.



HOTLINE

1-800-832-6825

Monday-Friday / Lunes-Viernes / Lundi-Vendredi	7:30 a.m. - 10:00 p.m.
Saturday / Sábado / Samedi	7:30 a.m. - 9:00 p.m.
Sunday / Domingo / Dimanche	9:00 a.m. - 8:00 p.m.
Eastern Time Zone / Zona horaria oriental / Fuseau horaire	

Hotline for catalog information, cross references and product applications
"Linea roja" para informacion del catalogo, referencias cruzadas y aplicaciones de productos
Ligne d'urgence pour catalogue, références, et information sur le produit

Minimum Information Required: Year, Make, Model, Engine
Información Mínima Requerida: El Año, Fabricante, Modelo, Motor
L'Information Minimum A Exigé: L'Année, Marque, Modèle, Moteur

Email: productsupport@valvoline.com

For application information and new models visit www.valvolinefilters.com
Para información de la aplicación y los nuevos modelos visita www.valvolinefilters.com
Pour des informations sur les applications et nouveaux modèles visitez www.valvolinefilters.com

Valvoline™ LIMITED WARRANTY

Valvoline™ filter products are warranted to their original purchaser to be free from defects in material and workmanship for the duration of the original equipment recommended change interval and **Valvoline™** hard parts (filters and hard parts are collectively referred to as, “Products”) are warranted to their original purchaser to be free from defects in material and workmanship for one (1) year from the later of the date of purchase or the date of installation. This warranty covers properly installed or utilized Products, installed in vehicles as cataloged by the then applicable **Valvoline™** product catalog (“Covered Products”). This warranty does not cover any Product that: a) has been subject to misuse, neglect, modification, negligence, accident or casualty; b) has been improperly installed; c) has been installed into an engine which is not referenced as a conforming application by the then applicable **Valvoline™** catalog; d) has remained in service beyond the original equipment recommended change interval; or e) has been used with a motor oil other than the viscosity and type as recommended in the vehicle owner’s manual **by the vehicle manufacturer.**

Any Covered Product which is determined by **Valvoline™** to be defective will be replaced at no charge. In the event of an engine or equipment failure directly caused by a Covered Product, **Valvoline™** will provide the lesser of the: i) restoration of the engine or equipment to a condition equivalent to that existing just prior to the failure or ii) cash payment of the fair market value of the vehicle. **TO THE FULLEST EXTENT ALLOWED UNDER APPLICABLE LAW, VALVOLINE DISCLAIMS ALL IMPLIED WARRANTIES AND CONDITIONS AND ANY AND ALL CONSEQUENTIAL, INCIDENTAL AND SPECIAL DAMAGES.** Some jurisdictions do not permit the exclusion of such warranties or damages, so this disclaimer may not apply to you.

You must cooperate with **Valvoline’s** claims management process. Please submit claims to **Valvoline™** within 30 days after discovery of damage. **Valvoline™** reserves the right to examine the engine, equipment and filter to determine the amount of damage and whether such damage was caused by a defective Covered Product. Therefore, claimants must take steps necessary to preserve the engine and/or equipment and the filter during the claims investigation period.

To initiate a claim in the United States, call **800-832-6825** or email: **productsupport@valvoline.com.**

This warranty gives you specific legal rights. You may have other rights which vary from jurisdiction to jurisdiction.

Valvoline™ reserves the right to make changes in design or improvements to its Filters without creating or assuming any obligation to install or implement the same on its Filters previously sold. In addition, Valvoline™ may change this limited warranty policy at any time. Please refer to www.valvolinefilters.com for the most current version of this limited warranty policy.

VEHICLE MANUFACTURERS’ WARRANTIES

In the United States: Use of **Valvoline™** Products will not void your Original Equipment warranty. A manufacturer may not require the use of any brand of filter unless either the manufacturer provides the filter for free-of-charge under terms of the warranty or the manufacturer successfully demonstrates to the Federal Trade Commission that its product will not work properly without a specified item or service. To date, the FTC has not made any such determination for filtration products. If a manufacturer makes a claim that using a **Valvoline™** product will void or has voided your warranty, ask the manufacturer to provide this statement in writing.

Outside of the United States: **Valvoline™** processes warranty claims on a world-wide basis. Check the terms of your Original Equipment warranty which may require the use of a specific brand of filter for a valid warranty claim and may limit or void the warranty as a result of the use or installation of other filters.

GARANTÍA LIMITADA DE *Valvoline*™

Los productos de filtrado *Valvoline*™ se garantizan ante el comprador original como libre de defectos en los materiales y en la mano de obra durante el período de validez del intervalo de cambio recomendado del equipo original y las piezas rígidas *Valvoline*™ (los filtros y las piezas rígidas se conocen colectivamente como “Productos”) se garantizan ante el comprador original como libre de defectos en los materiales y en la mano de obra durante un período de un (1) año a partir de la fecha de compra o la fecha de instalación, la que ocurra después. Esta garantía cubre los Productos correctamente instalados o utilizados, instalados en vehículos catalogados por el catálogo de productos *Valvoline*™ aplicable en ese momento (“Productos Cubiertos”). Esta garantía no cubre ningún Producto que: a) haya estado sujeto a uso indebido, abandono, negligencia, accidente o siniestro; b) haya sido instalado incorrectamente; c) haya sido instalado en un motor que no está listado como aplicación compatible por el catálogo de *Valvoline*™ aplicable en esos momentos; d) haya permanecido en servicio más allá del intervalo de cambio recomendado del equipo original; o e) haya sido usado con un aceite para motores de viscosidad o tipo diferentes, de acuerdo con las recomendaciones del fabricante del vehículo.

Cualquier Producto Cubierto que *Valvoline*™ hubiera determinado como defectuoso será reemplazado sin costo alguno. En el caso de una falla del motor o equipo directamente causado por un Producto Cubierto, *Valvoline*™ proporcionará el menor entre: i) la restauración del motor o equipo a una condición equivalente a aquella existente justo antes de la falla, o ii) un pago en efectivo del justo valor de mercado del vehículo. **AL GRADO MÁXIMO PERMITIDO BAJO LAS LEYES APLICABLES, *Valvoline*™ RENUNCIA A CUALQUIER GARANTÍA IMPLÍCITA Y CONDICIÓN, Y A CUALQUIERA Y TODO DAÑO RESULTANTE, INCIDENTAL Y ESPECIAL.** Algunas jurisdicciones no permiten la exclusión de tales garantías o daños, de modo que este descargo podría no aplicarse a su caso particular.

Usted deberá cooperar con el proceso de administración de reclamos de *Valvoline*™. Envíe los reclamos a *Valvoline*™ dentro de los 30 días de haber descubierto los daños. *Valvoline*™ se reserva el derecho de examinar el motor, equipo y filtro para determinar la cantidad de daños, y si estos fueron causados por un Producto Cubierto defectuoso. Por lo tanto, los reclamantes deberán tomar los pasos necesarios para proteger el motor y/o equipo, así como el filtro, durante el período de investigación de reclamos.

Para iniciar un reclamo en los Estados Unidos, llame al **800-832-6825** o envíe un mensaje por correo electrónico: **productsupport@valvoline.com**.

Esta garantía le otorga derechos legales específicos. Usted puede tener otros derechos que varían de una jurisdicción a otra.

***Valvoline*™ se reserva el derecho de hacer cambios en el diseño o mejoras a sus Filtros sin crear o asumir obligación alguna de tener que instalar o implementar dichos cambios en los Filtros que hubiera vendido previamente. Asimismo, *Valvoline*™ puede cambiar esta política de garantía limitada en cualquier momento. Consulte <http://www.valvolinefilters.com> para obtener la versión más actualizada de esta política de garantía limitada.**

GARANTÍAS DE LOS FABRICANTES DE VEHÍCULOS

En los Estados Unidos: El uso de productos *Valvoline*™ no anularán la garantía de su Equipo Original. Un fabricante no puede requerir el uso de ninguna marca de filtro a menos que dicho fabricante proporcione el filtro gratuitamente bajo los términos de la garantía o dicho fabricante demuestre satisfactoriamente ante la Comisión Federal de Comercio que su producto no funcionará correctamente sin un artículo o servicio especificado. Hasta la fecha, la FTC no ha hecho una determinación tal para los productos de filtración. Si un fabricante hace un reclamo que el uso de un producto *Valvoline*™ anulará o ha anulado su garantía, solicite que el fabricante proporcione esta declaración por escrito.

Fuera de los Estados Unidos: *Valvoline*™ procesa reclamos bajo la garantía a nivel mundial. Consulte los términos de la garantía de su Equipo Original que podría requerir el uso de una marca específica de filtro para realizar un reclamo válido bajo la garantía como resultado del uso o instalación de otros filtros.

GARANTIE LIMITÉE *Valvoline*[™]

Les filtres *Valvoline*[™] sont garantis exempts de vices de matériau et de fabrication pour l'acquéreur initial pour la durée de l'intervalle recommandé pour le remplacement de l'équipement d'origine. Les pièces dures *Valvoline*[™] (les filtres et les pièces dures seront mentionnés ci-après sous le nom de « Produits ») sont garantis exempts de vices de matériau et de fabrication pour l'acquéreur initial pendant un (1) an à compter soit de la date d'achat, soit de la date d'installation, selon la dernière de ces deux dates. Cette garantie couvre les produits correctement installés et utilisés, installés dans des véhicules comme l'indique le catalogue des produits *Valvoline*[™] en vigueur au moment de l'installation (« Produits couverts »). Cette garantie ne couvre aucun produit qui a) aurait fait l'objet d'un usage abusif ou négligent, d'un manque d'entretien ou ayant été impliqué dans un accident; b) aurait été mal installé; c) aurait été installé dans un moteur qui n'est pas mentionné comme application conforme dans le catalogue *Valvoline*[™] en vigueur au moment de l'installation; ou d) qui serait resté en service au-delà de l'intervalle de remplacement recommandé pour l'équipement d'origine ; ou e) aurait été utilisé avec une huile moteur d'une viscosité ou d'un type différent de ce qui a été recommandé **par le fabricant du véhicule.**

Tout produit couvert qui serait jugé défectueux par *Valvoline*[™] sera remplacé gratuitement. Au cas où une défaillance d'un moteur ou d'un équipement serait causée directement par le produit couvert, *Valvoline*[™] offrira la valeur la moindre des deux options qui suivent : i) remise du moteur ou du matériel en l'état équivalent à celui existant juste avant la défaillance ou ii) paiement en liquide de la juste valeur marchande du véhicule. **VALVOLINE[™] REJETTE, DANS TOUTE LA MESURE AUTORISÉE PAR LES LOIS EN VIGUEUR, TOUTES LES GARANTIES ET CONDITIONS IMPLICITES ET TOUS LES DOMMAGES CONSÉCUTIFS, ACCESSOIRES ET PARTICULIERS.** Certaines juridictions interdisent l'exclusion de telles garanties ou dommages, auquel cas il est possible que cette exonération de responsabilité ne s'applique pas à votre cas.

Vous devez respecter scrupuleusement le processus de gestion des réclamations établi par *Valvoline*[™]. Veuillez soumettre vos réclamations auprès de *Valvoline*[™] dans les trente jours qui suivent la découverte des dommages. *Valvoline*[™] se réserve le droit d'examiner le moteur, le matériel et le filtre pour déterminer l'importance des dommages et si ces dommages ont été causés par un Produit couvert défectueux. Par conséquent, les personnes se réclamant de la garantie doivent prendre les mesures nécessaires pour conserver le moteur et/ou le matériel et le filtre pour toute la durée de la période d'enquête faisant suite à la réclamation.

Pour lancer un processus de réclamation aux États-Unis, veuillez composer le **800-832-6825** ou envoyer un courriel à : **productsupport@valvoline.com**.

Cette garantie vous donne des droits légaux spécifiques. Vous pouvez avoir d'autres droits qui varient d'une juridiction à l'autre.

***Valvoline*[™] se réserve le droit de modifier ou d'améliorer la conception de ses filtres sans créer ou assumer une quelconque obligation d'installer ou de mettre en œuvre ces modifications ou améliorations sur ses filtres vendus antérieurement. En outre, *Valvoline*[™] se réserve le droit de modifier cette garantie limitée à tout moment. Veuillez consulter www.valvolinefilters.com pour obtenir la version la plus récente de cette garantie limitée.**

GARANTIES DU CONSTRUCTEUR DU VÉHICULE

Aux États-Unis: L'utilisation de produits *Valvoline*[™] n'annulera pas votre garantie pour l'équipement d'origine. Un constructeur ne peut exiger l'utilisation de quelque marque de filtre que ce soit à moins que le constructeur ne le fournisse sans frais dans le cadre de la garantie ou que le constructeur ait réussi à prouver à la Federal Trade Commission que ce produit ne pourra pas fonctionner correctement sans un article ou un service spécifié. À ce jour, la FTC n'a pris aucune décision concernant les produits de filtration. Si un constructeur déclare que l'utilisation d'un produit *Valvoline*[™] aura pour effet d'annuler la garantie ou a annulé la garantie, demandez au constructeur de vous remettre une copie écrite de cette déclaration.

En dehors des États-Unis: *Valvoline*[™] traite les réclamations en garantie à l'échelle mondiale. Consultez les termes de la garantie de votre équipement d'origine qui pourrait exiger l'utilisation d'une marque particulière de filtre pour que la réclamation en garantie soit valable ou qui pourrait limiter ou annuler la garantie du fait de l'utilisation ou de l'installation d'autres filtres.

Table of Contents

Subject

- How To Use This Catalog I-4
- New Products..... I-5
- Top 50 U.S. Vehicle Market Coverage I-6 – I-7
- Engine Identification..... I-8 – I-9
- Spanish Footnotes I-10 – I-11
- French Footnotes I-12 – I-13

- Applications..... 1-434

Section 1

- Cross Reference..... 1-88

Section 2

- **Cabin Air Installation Instructions** 1-146
- Over Pressurized Lube Oil Filters..... 147-149
- Oil Pressure Warning Light Problems . 150-152
- Standard vs. Metric..... 153
- Loss of Oil Pump Prime..... 154
- Notes 155
- Magnuson-Moss 156

Section 3

V-2385-19 (Issued March 2019)
Supersedes **V-2385-18**

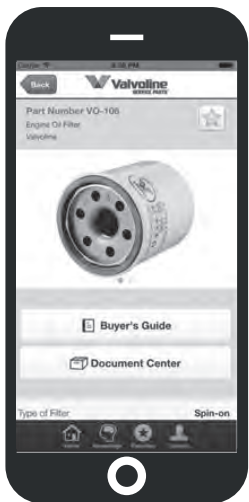

Contenido

Sección 1

- Aplicaciones 1-434

Sección 2

- Tabla de equivalencias da fabricantes..... 1-88

Sección 3

- **Instrucciones de instalación de aire de cabina**..... 1-146
- Filtros de aceite de lubricacion sobrepresurizados 147-149
- Problemas de la luz de alarma de presion de aceite..... 150-152
- Roscas estándar y métricas..... 153
- Perdida de empuje de la bomba de aceite 154
- Notas 155
- Magnuson-Moss 156

V-2385-19 (Publicado en marzo 2019)
 Substituye al **V-2385-18**

Tema

- Como usar este catálogo..... I-4
- Nuevos productos..... I-5
- Los 50 números de pieza principales para la cobertura del mercado de vehículos en EE. UU..... I-6 – I-7
- Identificación del motor I-8 – I-9
- Notas al pie en español I-10 – I-11
- Notas al pie en frances..... I-12 – I-13

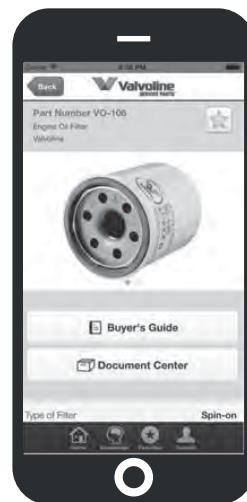
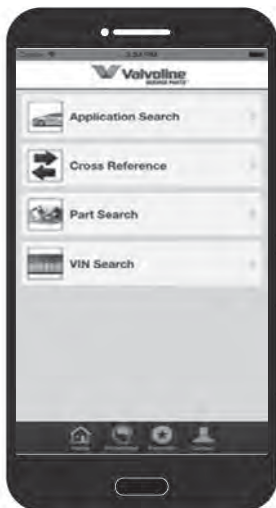

Table des matières

Sujet

- Comment utiliser ce catalogue I-4
- Nouveaux produits I-5
- Couverture des 50 premiers du marché automobile des États-Unis I-6 – I-7
- Identification moteur I-8 – I-9
- Notes explicatives en espagnol I-10 – I-11
- Notes explicatives en français I-12 – I-13

- Applications 1-434

Section 1

- Code de renvoi au fabricant 1-88

Section 2

- **Instructions d'installation air d'habitacle** 1-146
- Suppression des filtres à huile de lubrification 147-149
- Problèmes relatifs au témoin de pression d'huile 150-152
- Standard / Métrique 153
- Perte d'amorçage de pompe à huile 154
- Remarques 155
- Magnuson-Moss 156

Section 3

V-2385-19 (Parution mars 2019)
Remplace **V-2385-18**

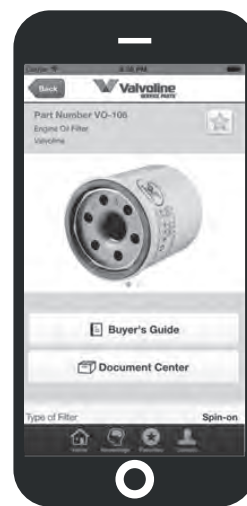
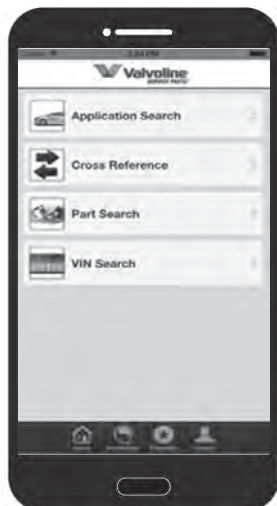

To Determine the Correct Product for a Vehicle

Cómo determinar el producto correcto para cada vehículo

Détermination du bon produit pour un véhicule donné

Because we build our catalog information by year, make, model and engine the following steps are necessary:

Debido a que nosotros ordenamos la información de nuestro catálogo por año, fabricante, modelo y motor, se necesita seguir los pasos siguientes:

Du fait que nous avons structuré les informations de notre catalogue par année, marque, modèle et moteur, les étapes suivantes d'identification sont nécessaires.



ACURA-2

1	2019				
3	ILX				
	4 cyl. 2.4L	VO-106		VCA-1063	NS ⁴³⁷
	MDX				
4	V6 3.0L Hybrid	VO-106	VA-456	VCA-1063	NS ⁴³⁷
	V6 3.5L	VO-106	VA-456	VCA-1063	NS ⁴³⁷
	NSX				
	V6 3.5L Turbo (Hybrid)		VA-297 ¹¹²	5	
	RDX				
	4 cyl. 2.0L Turbo	VO-106		VCA-1061	NS ⁴³⁷
	RLX				
	V6 3.5L	VO-106		VCA-1063	NS ⁴³⁷
	V6 3.5L Hybrid	VO-106		VCA-1063	NS ⁴³⁷
	TLX				

- 1** Determine the year. / Determine el año. / Déterminez l'année.
- 2** Determine the correct make. / Determine el fabricante. / Déterminez la bonne marque.
- 3** Determine the model. / Determine el modelo. / Déterminez le modèle.
- 4** Determine the engine. / Determine el motor. / Déterminez le moteur.
- 5** Footnote explanations are located at the bottom of the page on which they appear.
Las explicaciones de las notas se encuentran en el pie de la página en la que aparecen.
Les notes sont explicitées au bas de la page où elles sont marquées.

NOTE: All products to the right of the engine identification apply to that vehicle.

NOTA: Todos los productos indicados a la derecha de la identificación del motor se aplican a ese vehículo.

REMARQUE : Tous les produits listés à la droite de l'identification d'un moteur conviennent à ce véhicule.

Displacement Conversion Chart For Popular Engine Sizes

Tabla de conversión de cilindradas para los tamaños de motor mas comunes

Table de conversion de la cylindrée

Cubic Liters	Inches	Cubic Liters	Inches	Cubic Liters	Inches	Cubic Liters	Inches	Cubic Liters	Inches	Cubic Liters	Inches
1.0	61	1.6	98	2.2	134	2.8	171	3.3	200	4.0	243
1.1	67	1.7	105	2.2	135	2.8	173	3.4	207	4.1	250
1.2	73	1.8	109.5	2.3	140	2.9	177	3.5	214	4.1	252
1.3	79	1.8	109.8	2.4	146	2.9	180	3.6	220	4.2	255
1.4	86	1.9	118	2.5	150	3.0	184	3.7	225	4.2	258
1.5	92	2.0	121	2.5	151	3.1	189	3.8	229	4.3	260
1.6	96	2.0	121.7	2.6	156	3.2	196	3.8	231	4.3	262
1.6	97	2.0	122	2.6	158.6	3.2	198	3.8	232	4.3	265
1.6	97.6	2.1	128	2.7	165	3.3	198.5	3.9	238	4.4	267

1000cc EQUAL 1 LITER. 61.02 CUBIC INCHES EQUAL 1 LITER. 1000C.C. = 1LITRO 61,02 PULGADAS CUBICAS = 1LITRO 1000cc = 1 LITRE. 1 LITRE = 61.02 POUNCES CUBES.



2019 MODEL YEAR NEW PRODUCT INTRODUCTION

Part #	SAP #	Filter Type	Primary Application Information	OE Part #	UPC Code	Country of Origin	% of VIO
VO200	887349	Spin-on	Buick Cadillac Chevrolet GMC Vehicles (2012-19)	GM 12640445	074130038875	USA	1.1%
VO201	887350	Spin-on	Buick Lacrosse (2017-19), Regal (2018-19) Cadillac ATS, CT6, CTS (2016-19), XT5 (2017-19) Chevrolet Camaro (2016-19), Blazer (2019) GMC Acadia (2017-19)	GM 12693541	074130038899	USA	0.2%
VO202	887609	Spin-on	Cadillac XT4 2.0L (2019) Chevrolet Silverado 1500 4 Cyl. GMC Sierra 1500 4 Cyl. (2019)	GM 55495105	074130041356	USA	<0.1%
VA471	887401	Radial Seal Air	Chevrolet Cruze 1.4L Turbo (2016-19)	GM 13367308	074130038912	USA	0.2%
VA473	887403	Flexible Panel Air Filter	Fiat 500 Turbo 1.4L Turbo (2012-19)	FCA 68082570AA	074130038950	USA	0.0%
VA474	887404	Flexible Panel Air	Chevrolet Equinox 1.5L, 2.0L, 1.6L Diesel (2018-19) GMC Terrain 1.5L, 2.0L, 1.6L Diesel (2018-19)	GM 23249657	074130038974	USA	0.2%
VA485	887415	Air Filter	Chevrolet Express GMC Savana Van (2017-19)	GM 23327845	074130039384	USA	0.1%
VA488	887418	Flexible Panel Air	BMW 2 Series (2017-19), 3 Series (2016-19), 4 Series (2017-19), M240i (2017-19)	BMW 13718632502	074130039544	USA	0.1%
VA490	887420	Flexible Panel Air Filter	BMW Active Hybrid3 (2013-14), 335i Sedan only (2013-16)	BMW 13717602643	074130039582	USA	0.0%
VA497	887427	Rigid Panel Air Filter	Honda Accord 1.5L Turbo (2018-19)	Honda 17220-6A0-A00	074130039728	USA	0.1%
VA498	887428	Flexible Panel Air	Subaru Crosstrek, Impreza (2018-19)	Subaru 16546-AA16A	074130039742	USA	0.1%
VA499	887429	Panel Air Irregular shaped	Jeep JL Wrangler (2018-19)	Chrysler 68257030AA	074130039766	USA	<0.1%
VA500	887585	Rigid Panel Air	Toyota C-HR 2.0L (2017-19)	Toyota 17801-77050	074130044180	USA	<0.1%
VA501	887597	Flexible Panel Air	Ford Ecosport (2018-19)	Ford GN1Z-9601-A	074130041318	USA	<0.1%
VA502	887599	Panel Air Irregular shaped	Jeep Cherokee V6 (2019)	Chrysler 68245310AA	074130041301	USA	<0.1%
VA503	887619	Flexible Panel Air Filter	Jeep Cherokee 2.0L Turbo (2019)	Chrysler 68320315AB	074130044197	USA	<0.1%
VA504	887611	Flexible Panel Air Filter	Ram 1500 (2019)	Chrysler 68386779AA	074130041370	USA	<0.1%
VA505	887591	Panel Air Irregular shaped	Chevrolet Silverado 1500 GMC Sierra 1500 (2019)	GM 84121217	074130041288	USA	<0.1%
VCA2035	887431	Cabin Air Filter	Toyota Prius (2016-19)	Toyota 87139-28020	074130039803	USA	0.5%
VCA2043	887439	Cabin Air Filter	Nissan Versa (2015-18)	Nissan 27278-1KK0A	074130039964	USA	0.1%
VCA2051	887447	Cabin Air Filter	Subaru Accent (2019), Impreza (2017-19); Crosstrek (2018-19)	Subaru 72880-FL500	074130040267	USA	0.1%
VCA2055	887601	Cabin Air Filter	Toyota C-HR (2018-19)	Toyota 87139-F4010	074130041332	USA	<0.1%

Top 50 U.S. Vehicle Market Coverage / Los 50 números de pieza principales para la cobertura del mercado de vehículos en EE. UU. / Couverture des 50 premiers du marché automobile des États-Unis

Part # Número de referencia Numéro de pièce	Coverage Cobertura Couverture	Cumulative Acumulativa Cumulatifs
Oil Filters/Filtros de aceite/Filtres à huile		
VO-106	22.43%	22.43%
VO-88	18.01%	40.43%
VO-25	12.86%	53.30%
VO-118	4.67%	57.96%
VO-84	4.35%	62.31%
VO-16	3.64%	65.95%
VO-108	3.07%	69.02%
VO-40	2.47%	71.49%
VO-76	2.20%	73.68%
VO-58	1.98%	75.66%
VO-55	1.92%	77.58%
VO-114	1.90%	79.48%
VO-102	1.51%	80.99%
VO-200	1.04%	82.03%
VO-148	0.97%	83.00%
VO-56	0.97%	83.97%
VO-147	0.92%	84.89%
VO-98	0.92%	85.81%
VO-91	0.90%	86.71%
VO-64	0.72%	87.43%
VO-110	0.68%	88.11%
VO-75	0.61%	88.72%
VO-15	0.55%	89.28%
VO-87	0.55%	89.83%
VO-85	0.55%	90.38%
VO-113	0.54%	90.92%
VO-96	0.51%	91.43%
VO-65	0.49%	91.92%
VO-67	0.47%	92.39%
VO-103	0.46%	92.84%
VO-117	0.45%	93.29%
VO-101	0.42%	93.70%
VO-63	0.41%	94.11%
VO-149	0.39%	94.50%
VO-80	0.37%	94.87%
VO-81	0.36%	95.23%
VO-104	0.36%	95.59%
LC-8170	0.31%	95.90%

Part # Número de referencia Numéro de pièce	Coverage Cobertura Couverture	Cumulative Acumulativa Cumulatifs
Oil Filters/Filtros de aceite/Filtres à huile		
VO-109	0.31%	96.21%
VO-69	0.26%	96.47%
VO-115	0.22%	96.69%
VO-90	0.20%	96.89%
VO-66	0.20%	97.09%
VO-164	0.20%	97.29%
VO-86	0.15%	97.44%
VO-111	0.15%	97.59%
VO-141	0.14%	97.73%
VO-175	0.13%	97.86%
VO-77	0.13%	97.99%
VO-97	0.12%	98.11%

Part # Número de referencia Numéro de pièce	Coverage Cobertura Couverture	Cumulative Acumulativa Cumulatifs
Air Filters/Filtros de aire/Filtres à air		
VA-259	3.56%	3.56%
VA-271	2.67%	6.22%
VA-94	2.61%	8.83%
VA-86	2.52%	11.36%
VA-223	2.24%	13.60%
VA-273	2.13%	15.73%
VA-198	1.70%	17.43%
VA-224	1.64%	19.07%
VA-163	1.54%	20.62%
VA-78	1.49%	22.11%
VA-160	1.46%	23.57%
VA-214	1.32%	24.89%
VA-231	1.32%	26.21%
VA-154	1.20%	27.42%
VA-90	1.18%	28.59%
VA-105	1.17%	29.76%
VA-288	1.14%	30.91%
VA-2	1.13%	32.04%
VA-149	1.04%	33.08%
VA-108	0.95%	34.03%
VA-176	0.93%	34.96%
VA-255	0.92%	35.88%
VA-209	0.90%	36.78%
VA-102	0.89%	37.67%
VA-225	0.87%	38.54%
VA-109	0.86%	39.40%
VA-261	0.85%	40.25%
VA-265	0.81%	41.06%
VA-309	0.80%	41.85%
VA-171	0.77%	42.63%
VA-324	0.75%	43.38%
VA-260	0.73%	44.11%
VA-205	0.71%	44.81%
VA-161	0.68%	45.50%
VA-306	0.66%	46.16%
VA-258	0.65%	46.81%
VA-312	0.64%	47.45%
VA-202	0.64%	48.08%
VA-70	0.63%	48.71%

NOTE: Availability and order lead time for filters with lower coverage could vary by region. Please confirm with your local sales representative. / **NOTA:** La disponibilidad y el plazo de entrega de los pedidos de filtros con cobertura inferior podrían variar según la región. Sírvase confirmarlos con su representante local de ventas. / **REMARQUE :** Selon les régions, la disponibilité et les délais de livraison des filtres avec une couverture réduite sont sujets à variation. Veuillez confirmer auprès de votre représentant des ventes local.

Top 50 U.S. Vehicle Market Coverage / Los 50 números de pieza principales para la cobertura del mercado de vehículos en EE. UU. / Couverture des 50 premiers du marché automobile des États-Unis

Part # Número de referencia Numéro de pièce	Coverage Cobertura Couverture	Cumulative Acumulativa Cumulatifs
Air Filters/Filtros de aire/Filtres à air		
VA-182	0.62%	49.33%
VA-195	0.61%	49.94%
VA-132	0.60%	50.55%
VA-274	0.60%	51.15%
VA-286	0.60%	51.74%
VA-300	0.59%	52.33%
VA-302	0.59%	52.92%
VA-304	0.59%	53.51%
VA-162	0.56%	54.06%
VA-296	0.56%	54.62%
VA-334	0.55%	55.18%

Part # Número de referencia Numéro de pièce	Coverage Cobertura Couverture	Cumulative Acumulativa Cumulatifs
Cabin Air Filters/Filtros de aire de cabina/Filtres d'air d'habitacle		
VCA-1031	11.84%	11.84%
VCA-1063	8.71%	20.55%
VCA-1075	2.97%	23.52%
VCA-1014	2.78%	26.30%
VCA-1173	2.77%	29.07%
VCA-1078C	2.66%	31.73%
VCA-1002	2.16%	33.89%
VCA-1081	2.00%	35.89%
VCA-1017	1.89%	37.79%
VCA-1003	1.87%	39.65%
VCA-1069	1.85%	41.51%
VCA-1044	1.80%	43.31%
VCA-1135	1.71%	45.01%
VCA-1082	1.64%	46.65%
VCA-1184	1.64%	48.30%
VCA-1074	1.53%	49.83%
VCA-1068	1.50%	51.33%
VCA-1037	1.45%	52.77%
VCA-1061	1.43%	54.20%
VCA-1055	1.35%	55.55%
VCA-1185	1.35%	56.90%
VCA-1118	1.34%	58.24%
VCA-1080	1.27%	59.51%
VCA-1174	1.22%	60.73%
VCA-1038	1.18%	61.91%
VCA-1047	1.12%	63.03%
VCA-1012	1.12%	64.14%
VCA-1010	1.08%	65.23%
VCA-1073	1.06%	66.29%
VCA-1051	1.06%	67.35%
VCA-1028	0.87%	68.22%
VCA-1065	0.86%	69.08%
VCA-1041	0.81%	69.89%
VCA-1013	0.80%	70.69%
VCA-1171	0.80%	71.49%
VCA-1022	0.79%	72.28%
VCA-1001	0.79%	73.07%
VCA-1170	0.77%	73.84%

Part # Número de referencia Numéro de pièce	Coverage Cobertura Couverture	Cumulative Acumulativa Cumulatifs
Cabin Air Filters/Filtros de aire de cabina/Filtres d'air d'habitacle		
VCA-1077	0.76%	74.60%
VCA-1167	0.76%	75.37%
VCA-1049	0.76%	76.12%
VCA-1178	0.75%	76.88%
VCA-1097	0.75%	77.63%
VCA-1175	0.75%	78.38%
VCA-1034	0.72%	79.10%
VCA-1176	0.64%	79.74%
VCA-1026	0.63%	80.37%
VCA-2033	0.62%	80.98%
VCA-1153	0.57%	81.56%
VCA-1104	0.57%	82.13%

NOTE: Availability and order lead time for filters with lower coverage could vary by region. Please confirm with your local sales representative. / **NOTA:** La disponibilidad y el plazo de entrega de los pedidos de filtros con cobertura inferior podrían variar según la región. Sírvase confirmarlos con su representante local de ventas. / **REMARQUE :** Selon les régions, la disponibilité et les délais de livraison des filtres avec une couverture réduite sont sujets à variation. Veuillez confirmer auprès de votre représentant des ventes local.

Vehicle Engine Identification

Identificación del motor de vehículos

Identification du moteur des véhicules

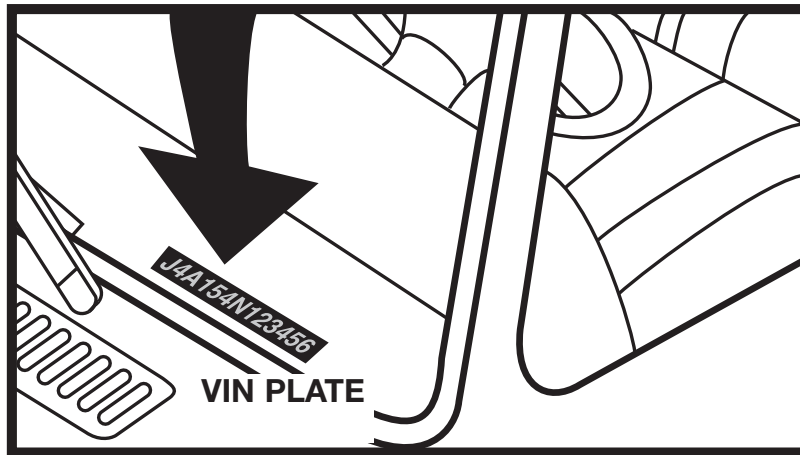

In some vehicles, there are two or more engines that are of the same size but do not use the same products.

To identify the proper product for your vehicle, you must match the engine code from your vehicle identification number with the character listed in our Application Section.

For vehicles manufactured by Chrysler, Ford, GM or Saab from 1972 to 1980, use the fifth character. For vehicles manufactured by Chrysler, Ford, GM or Saab from 1981 to 2019, use the eighth character.

For vehicles manufactured by Mitsubishi from 1983 to 2019, use the eighth character.

For vehicles manufactured by AMC/EAGLE (except Jeep) from 1972 to 1980 use the seventh character, from 1981 to 1988 use the fourth character, and 1989-1998 use the eighth character.

For vehicles manufactured by Jeep from 1972 to 1974 (up to SN #100000), use the eighth character, from 1974 to 1980 use the seventh character, from 1981 to 1988 use the fourth character, and from 1989-2019 use the eighth character.

For vehicles manufactured by AM General from 1995 to 2019 use the fourth character.

For vehicles manufactured by Hyundai - Mazda from 1981 to 2019 use the eighth character.

For vehicles manufactured by Jaguar - Landrover from 1981 to 2019 use the seventh character.

For vehicles manufactured by Kia from 1994 to 2019 use the eighth character.

For vehicles manufactured by Nissan (except Quest) from 1995 to 2019 use the fourth character.

For vehicles manufactured by Subaru - Suzuki from 1981 to 2019 use the sixth character.

2019 usar el octavo carácter.

Para vehículos fabricados por AM General desde 1995 hasta 2019, usar el cuarto carácter.

Para vehículos fabricados por Hyundai - Mazda desde 1981 hasta 2019, usar el octavo carácter.

Para vehículos fabricados por Jaguar - Landrover desde 1981 hasta 2019, usar el séptimo carácter.

Para vehículos fabricados por Kia desde 1994 hasta 2019, usar el octavo carácter.

Para vehículos fabricados por Nissan (excepto Quest) desde 1995 hasta 2019, usar el cuarto carácter.

Para vehículos fabricados por Subaru - Suzuki desde 1981 hasta 2019, usar el sexto carácter.

Certains modèles de véhicules sont construits avec des moteurs possédant une cylindrée identique mais qui utilisent des produits différents.

Afin d'identifier le produit approprié pour votre véhicule, vous devez faire correspondre le code d'identification du moteur faisant partie du numéro d'identification du véhicule avec le caractère inscrit sur la liste de notre section Applications.

Pour les véhicules construits par Chrysler, Ford, GM ou Saab de 1972 à 1980, utilisez le cinquième caractère. Pour les véhicules construits par Chrysler, Ford, GM ou Saab de 1981 à 2019, utilisez le huitième caractère.

Pour les véhicules construits par Mitsubishi de 1983 à 2019, utilisez le huitième caractère.

Pour les véhicules construits par AMC/EAGLE (sauf Jeep) de 1972 à 1980, utilisez le septième caractère. Pour les modèles construits entre 1981 et 1988, utilisez le quatrième caractère et entre 1989 et 1998, utilisez le huitième caractère.

Pour les véhicules construits par Jeep de 1972 à 1974 (jusqu'à SN N°100000), utilisez le huitième caractère. Pour les modèles construits entre 1974 et 1980, utilisez le septième caractère, pour les modèles construits entre 1981 et 1988, utilisez le quatrième caractère et entre 1989 et 2019, utilisez le huitième caractère.

Pour les véhicules construits par AM General de 1995 à 2019, utilisez le quatrième caractère.

Pour les véhicules construits par Hyundai - Mazda de 1981 à 2019, utilisez le huitième caractère.

Pour les véhicules construits par Jaguar - Landrover de 1981 à 2019, utilisez le septième caractère.

Pour les véhicules construits par Kia de 1994 à 2019, utilisez le huitième caractère.

Pour les véhicules construits par Nissan (sauf Quest) de 1995 à 2019, utilisez le quatrième caractère.

Pour les véhicules construits par Subaru - Suzuki de 1981 à 2019, utilisez le sixième caractère.

En algunos vehículos, hay dos o más motores que son del mismo tamaño pero no usan los mismos productos.

Para identificar el producto apropiado para su vehículo, usted deberá hermanar el código de motor de su número de identificación de vehículo con el carácter listado en nuestra Sección de Aplicación.

Para vehículos fabricados por Chrysler, Ford, GM o Saab desde 1972 hasta 1980, usar el quinto carácter. Para vehículos fabricados por Chrysler, Ford, GM o Saab desde 1981 hasta 2019, usar el octavo carácter.

Para vehículos fabricados por Mitsubishi desde 1983 hasta 2019, usar el octavo carácter.

Para vehículos manufacturados por AMC/Eagle (excepto Jeep) desde 1972 hasta 1980, usar el séptimo carácter, desde 1981 hasta 1988 usar el cuarto carácter, y para 1989-1998 usar el octavo carácter.

Para vehículos manufacturados por Jeep desde 1972 hasta 1974 (hasta SN #100000), usar el octavo carácter, de 1974 a 1980 usar el séptimo carácter, de 1981 a 1988 usar el cuarto carácter, y de 1989 a

Vehicle Engine Identification

Identificación del motor de vehículos

Identification du moteur des véhicules

CHRYSLER, FORD, GM AND/Y/ET SAAB

1972-1980

1H35L7R100001



ENGINE CODE
FIFTH CHARACTER
CÓDIGO DE MOTOR
QUINTO CARÁCTER
CODE DU MOTEUR
CINQUIÈME CARACTÈRE

1981-2019

1G3AL69N6CM100001



ENGINE CODE
EIGHTH CHARACTER
CÓDIGO DE MOTOR
OCTAVO CARÁCTER
CODE DU MOTEUR
HUITIÈME CARACTÈRE

AM GENERAL

1995-2019

137XE84H2MRE13201



ENGINE CODE
FOURTH CHARACTER
CÓDIGO DE MOTOR
CUARTO CARÁCTER
CODE DU MOTEUR
QUATRIÈME CARACTÈRE

MITSUBISHI

1983-2019

JA4MT41PMWP123456



ENGINE CODE
EIGHTH CHARACTER
CÓDIGO DE MOTOR
OCTAVO CARÁCTER
CODE DU MOTEUR
HUITIÈME CARACTÈRE

HYUNDAI - MAZDA

1981-2019

KMBRF23S3MZ000001



ENGINE CODE
EIGHTH CHARACTER
CÓDIGO DE MOTOR
OCTAVO CARÁCTER
CODE DU MOTEUR
HUITIÈME CARACTÈRE

AMC/EAGLE (except/excepto/sauf Jeep)

1972-1980

A3M798Z700001



ENGINE CODE
SEVENTH CHARACTER
CÓDIGO DE MOTOR
SÉPTIMO CARÁCTER
CODE DU MOTEUR
SEPTIÈME CARACTÈRE

1981-1988

2CEUN3870GB529063



ENGINE CODE
FOURTH CHARACTER
CÓDIGO DE MOTOR
CUARTO CARÁCTER
CODE DU MOTEUR
QUATRIÈME CARACTÈRE

JAGUAR - LANDROVER

1981-2019

SAJAV130-GR000002



ENGINE CODE
SEVENTH CHARACTER
CÓDIGO DE MOTOR
SÉPTIMO CARÁCTER
CODE DU MOTEUR
SEPTIÈME CARACTÈRE

1989-1998

2E3BB66U9LH038364



ENGINE CODE
EIGHTH CHARACTER
CÓDIGO DE MOTOR
OCTAVO CARÁCTER
CODE DU MOTEUR
HUITIÈME CARACTÈRE

KIA

1994-2019

KNASA231XS0000001



ENGINE CODE
EIGHTH CHARACTER
CÓDIGO DE MOTOR
OCTAVO CARÁCTER
CODE DU MOTEUR
HUITIÈME CARACTÈRE

JEEP

1972-1974 (up to SN #100000)
(jusqu'à SN #100000)
(hasta SN #100000)

J4A154CN00001



ENGINE CODE
EIGHTH CHARACTER
CÓDIGO DE MOTOR
OCTAVO CARÁCTER
CODE DU MOTEUR
HUITIÈME CARACTÈRE

1974-1980 (from SN #100000)
(de SN #100000)
(desde SN #100000)

J4A154N100000



ENGINE CODE
SEVENTH CHARACTER
CÓDIGO DE MOTOR
SÉPTIMO CARÁCTER
CODE DU MOTEUR
SEPTIÈME CARACTÈRE

1981-1988

1JT HE7560G430952



ENGINE CODE
FOURTH CHARACTER
CÓDIGO DE MOTOR
CUARTO CARÁCTER
CODE DU MOTEUR
QUATRIÈME CARACTÈRE

1989-2019

1J4ET37L5LT438789



ENGINE CODE
EIGHTH CHARACTER
CÓDIGO DE MOTOR
OCTAVO CARÁCTER
CODE DU MOTEUR
HUITIÈME CARACTÈRE

NISSAN (except/excepto/sauf Quest)

1995-2019

JN1PS3546X000001



ENGINE CODE
FOURTH CHARACTER
CÓDIGO DE MOTOR
CUARTO CARÁCTER
CODE DU MOTEUR
QUATRIÈME CARACTÈRE

SUBARU - SUZUKI

1981-2019

JF1AC45BYGCZ00001



ENGINE CODE
SIXTH CHARACTER
CÓDIGO DE MOTOR
SEXTO CARÁCTER
CODE DU MOTEUR
SIXIÈME CARACTÈRE

Notas al pie de la página

<p>50 Con carcasa instalada en agencia</p> <p>84 Filtro en línea</p> <p>112 Requiere dos (2)</p> <p>128 Excepto CNG</p> <p>186 Excepto funcionamiento especial</p> <p>211 Filtro para polvo</p> <p>221 Filtro de reemplazo OEM</p> <p>364 9.75 pulg. de largo</p> <p>394 Sin soporte</p> <p>437 Requiere reemplazo de la bomba completa de combustible/modulo de filtración de combustible</p> <p>449 Sin inducción de aire frío</p> <p>450 Filtro re-usable. No require reemplazo bajo condiciones normales de operación</p> <p>496 Antes de V.I.N. M45255</p> <p>561 El kit Ford número F65Z-18D477AA deberá estar instalado</p> <p>643 Cupé o Convertible; Sedán VA-490</p> <p>667 Filtro para polvo</p> <p>0762 Control estándar del filtro para polvo</p> <p>873 Con caja rectangular para filtro de aire</p> <p>880 Si está equipado con un filtro de aire para la cabina</p> <p>881 Antes de 1/17/2017</p> <p>897 Servicio pesado</p> <p>908 Aire tipo panel</p> <p>931 Servicio estándar</p> <p>1048 Modelos que requieren un filtro con vástago</p> <p>1125 Con caja de aluminio para filtro</p> <p>1134 Filtro para polvo. Reemplazar con VCA-1032 al agotarse el inventario</p> <p>1203 Anillo tórico suministrado no para motor 3.5L. Reutilizar la junta tórica de Viton</p> <p>1504 Alternativo. VO-25 primario</p> <p>X014 Versión de tapas plásticas</p> <p>X019 Filtro para polvo</p> <p>X039 Largo 14 1/2 pulg.</p> <p>X048 Sólo Sedán (requiere dos filtros)</p> <p>X102 Vástago roscado de 22mm</p>	<p>X111 Filtro para polvos y olores opcional. Use únicamente si el vehículo está equipado con una caja para el filtro de aire de la cabina</p> <p>X133 Filtro para polvo</p> <p>X135 Se realiza el mantenimiento del filtro para polvo debajo del capó</p> <p>X161 Tracción en 2 llantas</p> <p>X180 Filtro para polvo debajo del tablero</p> <p>X323 Vástago roscado de 3/4 pulg.</p> <p>X338 Antes de 5/10/07</p> <p>X344 Filtro para polvo</p> <p>X348 Transmisión automática</p> <p>X362 Excepto policía</p> <p>X367 12" (305 mm) de diámetro exterior</p> <p>X370 Con vástago roscado de 22 mm</p> <p>X374 Cartucho</p> <p>X385 Servicio estándar</p> <p>X388 Para aire tipo cónico</p> <p>X401 Filtro para polvos y olores</p> <p>X403 Después de 12/98</p> <p>X410 Filtro largo</p> <p>X421 Antes de 8/27/07</p> <p>X427 Filtro con 5.1 pulg. de altura</p> <p>X466 Filtro sellado</p> <p>X484 Todo excepto el paquete de policía después del 11/13/08</p> <p>X486 Antes de la producción 1/16/09</p> <p>X489 Antes de la producción 4/27/09</p> <p>X492 Filtro 11.50 x 7 pulg.</p> <p>X494 Enroscable</p> <p>X497 Sistemas DCC HVAC</p> <p>X502 Alternativo</p> <p>X504 Alternativo</p> <p>X505 Filtro para polvo</p> <p>X533 Sin emisiones de California</p> <p>X556 Excepto modelos de California</p> <p>X574 Roscas en ambos extremos</p> <p>X628 Filtro para polvo y olor</p> <p>X711 Con control automático de la temperatura</p> <p>X786 Sedán</p> <p>X788 Filtro sólo para partículas</p> <p>X871 Con filtro de 7.28" (187 mm) de ancho</p>	<p>X877 Con filtro de 8.98" (228 mm) de ancho</p> <p>X891 Filtro de 4 lados</p> <p>X892 Filtro con soporte lateral de plástico</p> <p>X903 Antes de 11/25/2015</p> <p>X905 Filtro sellado</p> <p>X907 Con la caja del filtro de aceite marcada como Hengst</p> <p>X909 Filtro para polvo</p> <p>X961 Filtro para polvos y olores</p> <p>X967 Filtro de cartucho</p> <p>Y133 Filtro para polvos y olores</p> <p>Y388 Aire tipo panel</p> <p>Z014 Versión de tapas metálicas</p> <p>Z019 Filtro para polvo y olor</p> <p>Z039 Largo 11 pulg.</p> <p>Z048 Cupé</p> <p>Z102 Vástago roscado de 3/4 pulg.</p> <p>Z111 Filtro para polvo</p> <p>Z133 Filtro para polvo y carcasa</p> <p>Z135 El filtro para polvo y olores se repara debajo de la guantera</p> <p>Z161 Tracción en 4 llantas</p> <p>Z180 Filtro para polvo por delante del parabrisas</p> <p>Z323 Vástago roscado de 22mm</p> <p>Z338 Después de 5/10/07</p> <p>Z344 Filtro para polvos y olores</p> <p>Z348 Transmisión manual</p> <p>Z362 Policía</p> <p>Z367 9.75" (248 mm) de diámetro exterior</p> <p>Z370 Con vástago roscado de 3/4 pulg.</p> <p>Z374 Enroscable</p> <p>Z385 Servicio pesado</p> <p>Z388 Aire tipo cónico sin domo</p> <p>Z401 Filtro para polvo</p> <p>Z403 Antes de 12/98</p> <p>Z410 Filtro corto</p> <p>Z421 Después de 8/26/07</p> <p>Z427 Filtro con 4.2 pulg. de altura</p> <p>Z466 Filtro de cartucho</p> <p>Z484 Con paquete de policía después del 11/13/08</p> <p>Z486 Después de la producción 1/15/09</p> <p>Z489 Después de la producción 1/15/09</p>
---	--	--

Notas al pie de la página (continúa)

Z492 Filtro 11 x 9.35 pulg. Z494 Filtro de cartucho Z497 Sistemas HCC HVAC Z502 Primario Z504 Primario Z505 Para paquete de batería de alto voltaje en el panel trasero del lado del conductor Z533 Con emisiones de California Z556 California Z574 Roscas en un extremo Z628 Filtro para polvo Z711 Sin control automático de la temperatura Z786 Cupé Z788 Partículas y olores Z871 Con filtro de 8.12" (206 mm) de ancho Z877 Con filtro de 8.2" (208 mm) de ancho Z891 Filtro de 5 lados Z892 Filtro sin soporte lateral de plástico Z903 11/25/2015 en adelante Z905 Filtro de cartucho Z907 Con la caja del filtro de aceite marcada como UFI Z909 Paquete de batería de alto voltaje en el panel trasero del lado del conductor Z961 Solo polvo Z967 Enroscable		
---	--	--

Notes en bas de page

50 Avec logement installé par le concessionnaire	X111 Filtre antipoussière et anti-odeur optionnel. N'utiliser que si le véhicule est équipé d'un logement pour filtre à air de cabine	X711 Avec contrôle automatique de la température dans le véhicule
84 Filtre en ligne		X786 Limousine
112 Deux pièces nécessaires (2)		X788 Filtre à particules seulement
128 Sauf CNG	X133 Filtre antipoussière	X871 Avec filtre de 18,49 cm (7,28 po) de large
186 Sauf hautes performances	X135 Filtre anti-poussière avec accès entretien sous le capot	X877 Avec filtre de 22,80 cm (8,98 po) de large
211 Filtre antipoussière	X161 À deux roues motrices	X891 Filtre quatre côtés
221 Filtre de remplacement du filtre d'origine	X180 Filtre antipoussière sous le tableau de bord	X892 Filtre avec support latéral en plastique
364 Longueur 9,75 po	X323 Tige filetée de 3/4"	X903 Avant le 25/11/2015
394 Sans support	X338 Avant le 5/10/07	X905 Filtre vissable
437 Nécessite le remplacement de l'ensemble du module pompe à carburant/filtre à carburant	X344 Filtre antipoussière	X907 Avec boîtier de filtre à huile avec la référence Hengst
449 Sans induction d'air froid	X348 Transmission automatique	X909 Filtre antipoussière
450 Filtre réutilisable à vie. Ne nécessite aucun remplacement dans des conditions normales	X362 Sauf police	X961 Filtre antipoussière et anti-odeur
496 Avant le V.I.N. M45255	X367 Diamètre extérieur de 305 mm (12 po)	X967 Filtre à cartouche
561 Kit Ford, numéro F65Z-18D477AA doit être installé	X370 Avec goujon fileté de 22 mm	Y133 Filtre antipoussière et anti-odeur
643 Coupé ou décapotable; Limousine VA-490	X374 Cartouche	Y388 Filtre à air panneau
667 Filtre antipoussière	X385 Service standard	Z014 Version avec bouchon métallique
0762 Commande standard pour filtre anti-poussière	X388 Filtre à air conique	Z019 Filtre antipoussière et anti-odeur
873 Avec caisson rectangulaire	X401 Filtre antipoussière et anti-odeur	Z039 11 po de long
880 Si équipé avec le filtre à air d'habitacle	X403 Après le 12/98	Z048 Coupé
881 Avant le 17/1/2017	X410 Filtre long	Z102 Tige filetée de 3/4"
897 Conditions de service extrêmes	X421 Avant le 27/8/07	Z111 Filtre antipoussière
908 Filtre à air panneau	X427 Avec une hauteur de filter de 5,1 po	Z133 Filtre antipoussière et logement
931 Service standard	X466 Filtre vissable	Z135 Filtre anti-poussière et anti-odeur avec accès entretien sous la boîte à gants
1048 Modèles nécessitant un filtre avec tige	X484 Tous, à l'Saufion de l'ensemble pour voiture de police après le 13/11/08	Z161 Quatre roues motrices
1125 Avec logement de filtre en aluminium	X486 Pour production avant le 16/1/09	Z180 Devant le pare-brise filtre anti-poussière
1134 Filtre anti-poussière. remplacer avec le VCA-1032 si l'inventaire est épuisé	X489 Pour production avant le 27/4/09	Z323 Tige filetée de 22mm
1203 Le joint torique fourni n'est pas pour le moteur 3,5L. Ré-utiliser le joint torique en Viton	X492 Filtre de 11,5 po x 7 po	Z338 Après le 10/5/07
1504 Alternatif. Principal VO-25	X494 Vissable	Z344 Filtre antipoussière et anti-odeur
X014 Version avec bouchon plastique	X497 Systèmes de chauffage/ climatisation DCC	Z348 Transmission manuelle
X019 Filtre antipoussière	X502 Alternatif	Z362 Police
X039 14-1/2 po de long	X504 Alternatif	Z367 Diamètre extérieur de 248 mm (9,75 po)
X048 Berline seulement (nécessite deux filtres)	X505 Filtre antipoussière	Z370 Avec goujon fileté de 3/4 po
X102 Tige filetée de 22mm	X533 Sans émissions Californie	Z374 Vissable
	X556 À l'exception des modèles californiens	Z385 Service intensif
	X574 Filetage aux deux extrémités	Z388 Filtre à air conique sans dôme
	X628 Filtre antipoussière et anti-odeur	Z401 Filtre antipoussière
		Z403 Avant le 12/98

Notes en bas de page (suite)

Z410 Filtre courte		
Z421 Après le 26/8/07		
Z427 Avec une hauteur de filter de 4,2 po		
Z466 Filtre à cartouche		
Z484 Avec l'ensemble pour voiture de police après le 13/11/08		
Z486 Pour production après le 15/1/09		
Z489 Pour production après le 15/1/09		
Z492 Filtre de 11 po x 9,35 po		
Z494 Filtre à cartouche		
Z497 Systèmes de chauffage/ climatisation HCC		
Z502 Primaire		
Z504 Primaire		
Z505 Pour les batteries haute tension sur le panneau de finition arrière du côté conducteur		
Z533 Avec émissions Californie		
Z556 Californie		
Z574 Filetage à une extrémité		
Z628 Filtre antipoussière		
Z711 Sans contrôle automatique de la température dans le véhicule		
Z786 Coupé		
Z788 Particules et odeur		
Z871 Avec filtre de 20,32 cm (8,12 po) de large		
Z877 Avec filtre de 20,82 cm (8,2 po) de large		
Z891 Filtre cinq côtés		
Z892 Filtre sans support latéral en plastique		
Z903 À partir du 25/11/2015		
Z905 Filtre à cartouche		
Z907 Avec boîtier de filtre à huile avec la référence UFI		
Z909 Les batteries haute tension sur le panneau de finition arrière du côté conducteur		
Z961 Poussière uniquement		
Z967 Vissable		



ACURA

2019

ILX

4 cyl. 2.4L	VO-106		VCA-1063	NS ⁴³⁷
-------------	--------	--	----------	-------------------

MDX

V6 3.0L Hybrid	VO-106	VA-456	VCA-1063	NS ⁴³⁷
----------------	--------	--------	----------	-------------------

V6 3.5L	VO-106	VA-456	VCA-1063	NS ⁴³⁷
---------	--------	--------	----------	-------------------

NSX

V6 3.5L Turbo (Hybrid)		VA-297 ¹¹²		
------------------------	--	-----------------------	--	--

RDX

4 cyl. 2.0L Turbo	VO-106		VCA-1061	NS ⁴³⁷
-------------------	--------	--	----------	-------------------

RLX

V6 3.5L	VO-106		VCA-1063	NS ⁴³⁷
---------	--------	--	----------	-------------------

V6 3.5L Hybrid	VO-106		VCA-1063	NS ⁴³⁷
----------------	--------	--	----------	-------------------

TLX

4 cyl. 2.4	VO-106	VA-304	VCA-1063	NS ⁴³⁷
------------	--------	--------	----------	-------------------

V6 3.5	VO-106		VCA-1063	NS ⁴³⁷
--------	--------	--	----------	-------------------

2018

ILX

4 cyl. 2.4L	VO-106		VCA-1063	NS ⁴³⁷
-------------	--------	--	----------	-------------------

MDX

V6 3.0L Hybrid	VO-106	VA-456	VCA-1063	NS ⁴³⁷
----------------	--------	--------	----------	-------------------

V6 3.5L	VO-106	VA-456	VCA-1063	NS ⁴³⁷
---------	--------	--------	----------	-------------------

NSX

V6 3.5L Turbo (Hybrid)		VA-297 ¹¹²		
------------------------	--	-----------------------	--	--

RDX

V6 3.5L	VO-106	VA-393	VCA-1063	NS ⁴³⁷
---------	--------	--------	----------	-------------------

RLX

V6 3.5L	VO-106		VCA-1063	NS ⁴³⁷
---------	--------	--	----------	-------------------

V6 3.5L Hybrid	VO-106		VCA-1063	NS ⁴³⁷
----------------	--------	--	----------	-------------------

TLX

4 cyl. 2.4	VO-106	VA-304	VCA-1063	NS ⁴³⁷
------------	--------	--------	----------	-------------------

V6 3.5	VO-106		VCA-1063	NS ⁴³⁷
--------	--------	--	----------	-------------------

2017

ILX

4 cyl. 2.4L	VO-106		VCA-1063	NS ⁴³⁷
-------------	--------	--	----------	-------------------

MDX

V6 3.0L Hybrid	VO-106	VA-456	VCA-1063	NS
----------------	--------	--------	----------	----

V6 3.5L	VO-106	VA-456	VCA-1063	NS ⁴³⁷
---------	--------	--------	----------	-------------------

NSX

V6 3.5L Turbo (Hybrid)		VA-297 ¹¹²		
------------------------	--	-----------------------	--	--

RDX

V6 3.5L	VO-106	VA-393	VCA-1063	NS ⁴³⁷
---------	--------	--------	----------	-------------------

RLX

V6 3.5L	VO-106		VCA-1063	NS ⁴³⁷
---------	--------	--	----------	-------------------

V6 3.5L Hybrid	VO-106		VCA-1063	NS ⁴³⁷
----------------	--------	--	----------	-------------------

TLX

4 cyl. 2.4	VO-106	VA-304	VCA-1063	NS ⁴³⁷
------------	--------	--------	----------	-------------------

V6 3.5	VO-106		VCA-1063	NS ⁴³⁷
--------	--------	--	----------	-------------------

2016

ILX

4 cyl. 2.4L	VO-106		VCA-1063	NS ⁴³⁷
-------------	--------	--	----------	-------------------

MDX

V6 3.5L	VO-106	VA-456	VCA-1063	NS ⁴³⁷
---------	--------	--------	----------	-------------------

Se reporter à table de matière pour les notes en bas de page en français. Utilize el contenido para ver notas a pie.

NS - Non-Serviceable / Non réparable / No repairable LF - Life-Time Filter / Filtro para toda la vida / Filtre à vie

¹¹² Requires two (2). ⁴³⁷ Requires replacement of the complete fuel pump/fuel filter module.



ACURA (cont'd)

	Oil	Air	Cabin*	Fuel
2016				
RDX				
V6 3.5L	VO-106	VA-393	VCA-1063	NS ⁴³⁷
RLX				
V6 3.5L	VO-106		VCA-1063	NS ⁴³⁷
V6 3.5L Hybrid	VO-106		VCA-1063	NS ⁴³⁷
TLX				
4 cyl. 2.4	VO-106	VA-304	VCA-1063	NS ⁴³⁷
V6 3.5	VO-106		VCA-1063	NS ⁴³⁷
2015				
ILX				
4 cyl. 1.5L Hybrid	VO-106		VCA-1063	NS ⁴³⁷
4 cyl. 2.0L	VO-106	VA-292	VCA-1063	NS ⁴³⁷
4 cyl. 2.4L	VO-106	VA-297	VCA-1063	NS ⁴³⁷
MDX				
V6 3.5L	VO-106	VA-419	VCA-1063	NS ⁴³⁷
RDX				
V6 3.5L	VO-106	VA-393	VCA-1063	NS ⁴³⁷
RLX				
V6 3.5L	VO-106		VCA-1063	NS ⁴³⁷
V6 3.5L Hybrid	VO-106		VCA-1063	NS ⁴³⁷
TLX				
4 cyl. 2.4	VO-106	VA-304	VCA-1063	NS ⁴³⁷
V6 3.5	VO-106		VCA-1063	NS ⁴³⁷
2014				
ILX				
4 cyl. 1.5L Hybrid	VO-106		VCA-1063	NS ⁴³⁷
4 cyl. 2.0L	VO-106	VA-292	VCA-1063	NS ⁴³⁷
4 cyl. 2.4L	VO-106	VA-297	VCA-1063	NS ⁴³⁷
MDX				
V6 3.5L	VO-106	VA-419	VCA-1063	NS ⁴³⁷
RDX				
V6 3.5L	VO-106	VA-393	VCA-1063	NS ⁴³⁷
RLX				
V6 3.5L	VO-106		VCA-1063	NS ⁴³⁷
V6 3.5L Hybrid	VO-106		VCA-1063	NS ⁴³⁷
TL				
V6 3.5L	VO-106	VA-220	VCA-1063	NS ⁴³⁷
V6 3.7L	VO-106	VA-220	VCA-1063	NS ⁴³⁷
TSX				
4 cyl. 2.4L	VO-106	VA-294	VCA-1063	NS ⁴³⁷
V6 3.5L	VO-106	VA-220	VCA-1063	NS ⁴³⁷
2013				
ILX				
4 cyl. 1.5L Hybrid	VO-106		VCA-1063	NS ⁴³⁷
4 cyl. 2.0L	VO-106	VA-292	VCA-1063	NS ⁴³⁷
4 cyl. 2.4L	VO-106	VA-297	VCA-1063	NS ⁴³⁷
MDX				
V6 3.7L	VO-106	VA-390	VCA-1063	NS ⁴³⁷
RDX				
V6 3.5L	VO-106	VA-393	VCA-1063	NS ⁴³⁷
TL				
V6 3.5L	VO-106	VA-220	VCA-1063	NS ⁴³⁷

Se reporter à table de matière pour les notes en bas de page en français. Utilize el contenido para ver notas a pie.

NS - Non-Serviceable / Non réparable / No repairable LF - Life-Time Filter / Filtro para toda la vida / Filtre à vie

⁴³⁷ Requires replacement of the complete fuel pump/fuel filter module.



ACURA (cont'd)

2013

TL

V6 3.7L	VO-106	VA-220	VCA-1063	NS ⁴³⁷
---------	--------	--------	----------	-------------------

TSX

4 cyl. 2.4L	VO-106	VA-294	VCA-1063	NS ⁴³⁷
-------------	--------	--------	----------	-------------------

V6 3.5L	VO-106	VA-220	VCA-1063	NS ⁴³⁷
---------	--------	--------	----------	-------------------

ZDX

V6 3.7L FI	VO-106	VA-390	VCA-1063	NS ⁴³⁷
------------	--------	--------	----------	-------------------

2012

MDX

V6 3.7L	VO-106	VA-390	VCA-1063	NS ⁴³⁷
---------	--------	--------	----------	-------------------

RDX

4 cyl 2.3L FI Turbo	VO-106	VA-357	VCA-1063	NS ⁴³⁷
---------------------	--------	--------	----------	-------------------

RL

V6 3.7L FI	VO-106		VCA-1063	NS ⁴³⁷
------------	--------	--	----------	-------------------

TL

V6 3.5L	VO-106	VA-220	VCA-1063	NS ⁴³⁷
---------	--------	--------	----------	-------------------

V6 3.7L	VO-106	VA-220	VCA-1063	NS ⁴³⁷
---------	--------	--------	----------	-------------------

TSX

4 cyl. 2.4L	VO-106	VA-294	VCA-1063	NS ⁴³⁷
-------------	--------	--------	----------	-------------------

V6 3.5L	VO-106	VA-220	VCA-1063	NS ⁴³⁷
---------	--------	--------	----------	-------------------

ZDX

V6 3.7L FI	VO-106	VA-390	VCA-1063	NS ⁴³⁷
------------	--------	--------	----------	-------------------

2011

CSX

4 cyl 2.0L FI (Canada)	VO-106	VA-237	VCA-1063	NS ⁴³⁷
------------------------	--------	--------	----------	-------------------

MDX

V6 3.7L	VO-106	VA-390	VCA-1063	NS ⁴³⁷
---------	--------	--------	----------	-------------------

RDX

4 cyl 2.3L FI Turbo	VO-106	VA-357	VCA-1063	NS ⁴³⁷
---------------------	--------	--------	----------	-------------------

RL

V6 3.7L FI	VO-106		VCA-1063	NS ⁴³⁷
------------	--------	--	----------	-------------------

TL

V6 3.5L	VO-106	VA-220	VCA-1063	NS ⁴³⁷
---------	--------	--------	----------	-------------------

V6 3.7L	VO-106	VA-220	VCA-1063	NS ⁴³⁷
---------	--------	--------	----------	-------------------

TSX

4 cyl. 2.4L	VO-106	VA-294	VCA-1063	NS ⁴³⁷
-------------	--------	--------	----------	-------------------

V6 3.5L	VO-106	VA-220	VCA-1063	NS ⁴³⁷
---------	--------	--------	----------	-------------------

ZDX

V6 3.7L FI	VO-106	VA-390	VCA-1063	NS ⁴³⁷
------------	--------	--------	----------	-------------------

2010

CSX

4 cyl 2.0L FI (Canada)	VO-106	VA-237	VCA-1063	NS ⁴³⁷
------------------------	--------	--------	----------	-------------------

CSX Type-S

4 cyl 2.0L FI (Canada)	VO-106	VA-237	VCA-1063	NS ⁴³⁷
------------------------	--------	--------	----------	-------------------

MDX

V6 3.7L	VO-106	VA-390	VCA-1063	NS ⁴³⁷
---------	--------	--------	----------	-------------------

RDX

4 cyl 2.3L FI Turbo	VO-106	VA-357	VCA-1063	NS ⁴³⁷
---------------------	--------	--------	----------	-------------------

RL

V6 3.7L FI	VO-106		VCA-1063	NS ⁴³⁷
------------	--------	--	----------	-------------------

TL

V6 3.5L	VO-106	VA-220	VCA-1063	NS ⁴³⁷
---------	--------	--------	----------	-------------------

Se reporter à table de matière pour les notes en bas de page en français. Utilize el contenido para ver notas a pie.

NS - Non-Serviceable / Non réparable / No reparable LF - Life-Time Filter / Filtro para toda la vida / Filtre à vie

⁴³⁷ Requires replacement of the complete fuel pump/fuel filter module.



ACURA (cont'd)

	Oil	Air	Cabin*	Fuel
2010				
TL				
V6 3.7L	VO-106	VA-220	VCA-1063	NS ⁴³⁷
TSX				
4 cyl. 2.4L	VO-106	VA-294	VCA-1063	NS ⁴³⁷
V6 3.5L	VO-106	VA-220	VCA-1063	NS ⁴³⁷
ZDX				
V6 3.7L FI	VO-106	VA-390	VCA-1063	NS ⁴³⁷
2009				
CSX				
4 cyl 2.0L FI (Canada)	VO-106	VA-237	VCA-1063	NS ⁴³⁷
CSX Type-S				
4 cyl 2.0L FI (Canada)	VO-106	VA-237	VCA-1063	NS ⁴³⁷
MDX				
V6 3.7L FI	VO-106	VA-202	VCA-1063	NS ⁴³⁷
RDX				
4 cyl 2.3L FI Turbo	VO-106	VA-357	VCA-1063	NS ⁴³⁷
RL				
V6 3.7L FI	VO-106		VCA-1063	NS ⁴³⁷
TL				
V6 3.5L FI	VO-106	VA-220	VCA-1063	NS ⁴³⁷
V6 3.7L FI	VO-106	VA-220	VCA-1063	NS ⁴³⁷
TSX				
4 cyl. 2.4L FI	VO-106	VA-294	VCA-1063	NS ⁴³⁷
2008				
CSX				
4 cyl 2.0L FI (Canada)	VO-106	VA-237	VCA-1063	NS ⁴³⁷
CSX Type-S				
4 cyl 2.0L FI (Canada)	VO-106	VA-237	VCA-1063	NS ⁴³⁷
MDX				
V6 3.7L FI	VO-106	VA-202	VCA-1063	NS ⁴³⁷
RDX				
4 cyl 2.3L FI Turbo	VO-106	VA-357	VCA-1063	NS ⁴³⁷
RL				
V6 3.5L FI	VO-106	VA-184	VCA-1063	NS ⁴³⁷
TL				
V6 3.2L FI	VO-106	VA-351	VCA-1063	NS ⁴³⁷
TL Type-S				
V6 3.5L FI	VO-106	VA-351	VCA-1063	NS ⁴³⁷
TSX				
4 cyl. 2.4L FI	VO-106	VA-183	VCA-1063	NS ⁴³⁷
2007				
CSX				
4 cyl 2.0L FI (Canada)	VO-106	VA-237	VCA-1063	NS ⁴³⁷
CSX Type-S				
4 cyl 2.0L FI (Canada)	VO-106	VA-237	VCA-1063	NS ⁴³⁷
MDX				
V6 3.7L FI	VO-106	VA-202	VCA-1063	NS ⁴³⁷
RDX				
4 cyl 2.3L FI Turbo	VO-106	VA-357	VCA-1063	NS ⁴³⁷
RL				
V6 3.5L FI	VO-106	VA-184	VCA-1063	NS ⁴³⁷

Se reporter à table de matière pour les notes en bas de page en français. Utilize el contenido para ver notas a pie.

NS - Non-Serviceable / Non réparable / No reparable LF - Life-Time Filter / Filtro para toda la vida / Filtre à vie

⁴³⁷ Requires replacement of the complete fuel pump/fuel filter module.



ACURA (cont'd)

2007

TL

V6 3.2L FI	VO-106	VA-351	VCA-1063	NS ⁴³⁷
------------	--------	--------	----------	-------------------

TL Type-S

V6 3.5L FI	VO-106	VA-351	VCA-1063	NS ⁴³⁷
------------	--------	--------	----------	-------------------

TSX

4 cyl. 2.4L FI	VO-106	VA-183	VCA-1063	NS ⁴³⁷
----------------	--------	--------	----------	-------------------

2006

CSX

4 cyl 2.0L FI (Canada)	VO-106	VA-196	VCA-1012	NS ⁴³⁷
------------------------	--------	--------	----------	-------------------

MDX

V6 3.5L FI	VO-106	VA-192	VCA-1013	NS ⁴³⁷
------------	--------	--------	----------	-------------------

RL

V6 3.5L FI	VO-106	VA-184	VCA-1063	NS ⁴³⁷
------------	--------	--------	----------	-------------------

RSX

4 cyl. 2.0L FI	VO-106	VA-196	VCA-1012	NS ⁴³⁷
----------------	--------	--------	----------	-------------------

RSX Type-S

4 cyl. 2.0L FI	VO-106	VA-196	VCA-1012	NS ⁴³⁷
----------------	--------	--------	----------	-------------------

TL

V6 3.2L FI	VO-106	VA-184	VCA-1063	NS ⁴³⁷
------------	--------	--------	----------	-------------------

TSX

4 cyl. 2.4L FI	VO-106	VA-183	VCA-1063	NS ⁴³⁷
----------------	--------	--------	----------	-------------------

2005

EL (Canada)

4 cyl. 1.7L FI	VO-106	VA-165	VCA-1012	NS ⁴³⁷
----------------	--------	--------	----------	-------------------

MDX

V6 3.5L FI	VO-106	VA-192	VCA-1013	NS ⁴³⁷
------------	--------	--------	----------	-------------------

NSX

V6 3.0L FI	VO-60			
V6 3.2L FI	VO-60			

RL

V6 3.5L FI	VO-106	VA-184	VCA-1063	NS ⁴³⁷
------------	--------	--------	----------	-------------------

RSX

4 cyl. 2.0L FI	VO-106	VA-196	VCA-1012	NS ⁴³⁷
----------------	--------	--------	----------	-------------------

RSX Type-S

4 cyl. 2.0L FI	VO-106	VA-196	VCA-1012	NS ⁴³⁷
----------------	--------	--------	----------	-------------------

TL

V6 3.2L FI	VO-106	VA-184	VCA-1063	NS ⁴³⁷
------------	--------	--------	----------	-------------------

TSX

4 cyl. 2.4L FI	VO-106	VA-183	VCA-1063	NS ⁴³⁷
----------------	--------	--------	----------	-------------------

2004

EL (Canada)

4 cyl. 1.7L FI	VO-106	VA-165	VCA-1012	NS ⁴³⁷
----------------	--------	--------	----------	-------------------

MDX

V6 3.5L FI	VO-106	VA-192	VCA-1013	NS ⁴³⁷
------------	--------	--------	----------	-------------------

NSX

V6 3.0L FI	VO-60			
V6 3.2L FI	VO-60			

RL

V6 3.5L FI	VO-106	VA-148	VCA-1060	NS
------------	--------	--------	----------	----

RSX

4 cyl. 2.0L FI	VO-106	VA-196	VCA-1012	NS ⁴³⁷
----------------	--------	--------	----------	-------------------

Se reporter à table de matière pour les notes en bas de page en français. Utilize el contenido para ver notas a pie.

NS - Non-Serviceable / Non réparable / No reparable LF - Life-Time Filter / Filtro para toda la vida / Filtre à vie

⁴³⁷ Requires replacement of the complete fuel pump/fuel filter module.



ACURA (cont'd)

	Oil	Air	Cabin*	Fuel
2004				
RSX Type-S				
4 cyl. 2.0L FI	VO-106	VA-196	VCA-1012	NS ⁴³⁷
TL				
V6 3.2L FI	VO-106	VA-184	VCA-1063	NS ⁴³⁷
TSX				
4 cyl. 2.4L FI	VO-106	VA-183	VCA-1063	NS ⁴³⁷
2003				
CL				
V6 3.2L FI	VO-106	VA-118	VCA-1167	NS ⁴³⁷
CL Sport				
V6 3.2L FI	VO-106	VA-361	VCA-1167	NS ⁴³⁷
EL (Canada)				
4 cyl. 1.7L FI	VO-106	VA-165	VCA-1012	NS ⁴³⁷
MDX				
V6 3.5L FI	VO-106	VA-192	VCA-1013	NS ⁴³⁷
NSX				
V6 3.0L FI	VO-60			
V6 3.2L FI	VO-60			
RL				
V6 3.5L FI	VO-106	VA-148	VCA-1060	NS
RSX				
4 cyl. 2.0L FI	VO-106	VA-196	VCA-1012	NS ⁴³⁷
TL				
V6 3.2L FI	VO-106	VA-118	VCA-1167	NS ⁴³⁷
TL Sport				
V6 3.2L FI	VO-106	VA-361	VCA-1167	NS ⁴³⁷
2002				
CL				
V6 3.2L FI	VO-106	VA-118	VCA-1167	NS ⁴³⁷
CL Sport				
V6 3.2L FI	VO-106	VA-361	VCA-1167	NS ⁴³⁷
EL (Canada)				
4 cyl. 1.7L FI	VO-106	VA-165	VCA-1012	NS ⁴³⁷
MDX				
V6 3.5L FI	VO-106	VA-192	VCA-1013	NS ⁴³⁷
NSX				
V6 3.0L FI	VO-60			
V6 3.2L FI	VO-60			
RL				
V6 3.5L FI	VO-106	VA-148	VCA-1060	NS
RSX				
4 cyl. 2.0L FI	VO-106	VA-196	VCA-1012	NS ⁴³⁷
TL				
V6 3.2L FI	VO-106	VA-118	VCA-1167	NS ⁴³⁷
TL Sport				
V6 3.2L FI	VO-106	VA-361	VCA-1167	NS ⁴³⁷
2001				
CL				
V6 3.2L FI	VO-106	VA-118	VCA-1167	NS ⁴³⁷
CL Sport				
V6 3.2L FI	VO-106	VA-361	VCA-1167	NS ⁴³⁷

Se reporter à table de matière pour les notes en bas de page en français. Utilize el contenido para ver notas a pie.

NS - Non-Serviceable / Non réparable / No reparable LF - Life-Time Filter / Filtro para toda la vida / Filtre à vie

⁴³⁷ Requires replacement of the complete fuel pump/fuel filter module.



ACURA (cont'd)

2001

EL (Canada)

4 cyl. 1.7L FI	VO-106	VA-165		
----------------	--------	--------	--	--

Integra

4 cyl. 1.8L FI	VO-106	VA-338		
----------------	--------	--------	--	--

4 cyl. 1.8L FI (VTEC)	VO-106	VA-338		
-----------------------	--------	--------	--	--

MDX

V6 3.5L FI	VO-106	VA-192	VCA-1013	NS ⁴³⁷
------------	--------	--------	----------	-------------------

NSX

V6 3.0L FI	VO-60			
------------	-------	--	--	--

V6 3.2L FI	VO-60			
------------	-------	--	--	--

RL

V6 3.5L FI	VO-106	VA-148	VCA-1060	NS
------------	--------	--------	----------	----

TL

V6 3.2L FI	VO-106	VA-118	VCA-1167	NS ⁴³⁷
------------	--------	--------	----------	-------------------

2000

EL (Canada)

4 cyl. 1.6L FI	VO-106	VA-135	VCA-1012	
----------------	--------	--------	----------	--

Integra

4 cyl. 1.8L FI	VO-106	VA-338		
----------------	--------	--------	--	--

4 cyl. 1.8L FI (VTEC)	VO-106	VA-338		
-----------------------	--------	--------	--	--

NSX

V6 3.0L FI	VO-60			
------------	-------	--	--	--

V6 3.2L FI	VO-60			
------------	-------	--	--	--

RL

V6 3.5L FI	VO-106	VA-148	VCA-1060	
------------	--------	--------	----------	--

TL

V6 3.2L FI	VO-106	VA-118	VCA-1167	NS ⁴³⁷
------------	--------	--------	----------	-------------------

1999

CL

4 cyl. 2.3L FI	VO-106	VA-113		
----------------	--------	--------	--	--

V6 3.0L FI	VO-106			
------------	--------	--	--	--

EL (Canada)

4 cyl. 1.6L FI	VO-106	VA-135	VCA-1012	
----------------	--------	--------	----------	--

Integra

4 cyl. 1.8L FI	VO-106	VA-338		
----------------	--------	--------	--	--

4 cyl. 1.8L FI (VTEC)	VO-106	VA-338		
-----------------------	--------	--------	--	--

NSX

V6 3.0L FI	VO-60			
------------	-------	--	--	--

V6 3.2L FI	VO-60			
------------	-------	--	--	--

RL

V6 3.5L FI	VO-106	VA-148	VCA-1060	NS
------------	--------	--------	----------	----

SLX

V6 3.5L FI	VO-106	VFAP-7859		
------------	--------	-----------	--	--

TL

V6 3.2L FI	VO-106	VA-118	VCA-1167	NS ⁴³⁷
------------	--------	--------	----------	-------------------

1998

CL

4 cyl. 2.3L FI	VO-106	VA-113		
----------------	--------	--------	--	--

V6 3.0L FI	VO-106			
------------	--------	--	--	--

EL (Canada)

4 cyl. 1.6L FI	VO-106	VA-135	VCA-1012	
----------------	--------	--------	----------	--

Se reporter à table de matière pour les notes en bas de page en français. Utilize el contenido para ver notas a pie.

NS - Non-Serviceable / Non réparable / No reparable LF - Life-Time Filter / Filtro para toda la vida / Filtre à vie

⁴³⁷ Requires replacement of the complete fuel pump/fuel filter module.



ACURA (cont'd)

	Oil	Air	Cabin*	Fuel
1998				
Integra				
4 cyl. 1.8L FI	VO-106	VA-338		
4 cyl. 1.8L FI (VTEC)	VO-106	VA-338		
NSX				
V6 3.0L FI	VO-60			
V6 3.2L FI	VO-60			
RL				
V6 3.5L FI	VO-106	VA-148	VCA-1060	
SLX				
V6 3.5L FI	VO-106	VFAP-7859		
TL				
5 cyl. 2.5L FI	VO-106			
V6 3.2L FI	VO-60			
1997				
CL				
4 cyl. 2.2L FI (VTEC)	VO-106	VA-113		
V6 3.0L FI	VO-106			
EL (Canada)				
4 cyl. 1.6L FI	VO-106	VA-135	VCA-1012	
Integra				
4 cyl. 1.8L FI	VO-106	VA-338		
4 cyl. 1.8L FI (VTEC)	VO-106	VA-338		
NSX				
V6 3.0L FI	VO-60			
V6 3.2L FI	VO-60			
RL				
V6 3.5L FI	VO-106	VA-148	VCA-1060	
SLX				
V6 3.2L FI	VO-106	VFAP-7859		
TL				
5 cyl. 2.5L FI	VO-106			
V6 3.2L FI	VO-60			
1996				
Integra				
4 cyl. 1.8L FI	VO-106	VA-338		
4 cyl. 1.8L FI (VTEC)	VO-106	VA-338		
NSX				
V6 3.0L FI	VO-60			
RL				
V6 3.5L FI	VO-106	VA-148	VCA-1060	
SLX				
V6 3.2L FI	VO-106	VFAP-7859		
TL				
5 cyl. 2.5L FI	VO-106			
V6 3.2L FI	VO-60			
1995				
Integra				
4 cyl. 1.8L FI	VO-106	VA-338		
4 cyl. 1.8L FI (VTEC)	VO-106	VA-338		
Legend				
V6 3.2L FI	VO-60			

Se reporter à table de matière pour les notes en bas de page en français. Utilize el contenido para ver notas a pie.
 NS - Non-Serviceable / Non réparable / No reparable LF - Life-Time Filter / Filtro para toda la vida / Filtre à vie



ACURA (cont'd)

1995

NSX

V6 3.0L FI

VO-60

TL

5 cyl. 2.5L FI

VO-106

ALFA ROMEO

2019

4C

4 cyl. 1.7 Turbo

VO-106

NS

Giulia

4 cyl. 2.0L Turbo

VO-88

Stelvio

4 cyl. 2.0L Turbo

VO-88

2018

4C

4 cyl. 1.7 Turbo

VO-106

NS

Giulia

4 cyl. 2.0L Turbo

VO-88

Stelvio

4 cyl. 2.0L Turbo

VO-88

2017

4C

4 cyl. 1.7 Turbo

VO-106

NS

Giulia

4 cyl. 2.0L Turbo

VO-88

2016

4C

4 cyl. 1.7 Turbo

VO-106

NS

2015

4C

4 cyl. 1.7 Turbo

VO-106

NS

1995

164

V6 3.0L FI

VO-25

1994

164

V6 3.0L FI

VO-25

AUDI

2019

A3, A3 Quattro

4 cyl 1.4L Turbo (Hybrid)

VO-25

VCA-1189

LF⁴⁵⁰

4 cyl 2.0L Turbo

VO-117

VA-453

VCA-1189

LF⁴⁵⁰

A4 allroad

4 cyl. 2.0L DI Turbo (CYMC)

VO-117

NS⁴³⁷

A4, A4 Quattro

4 cyl. 2.0L Turbo

VO-117

NS⁴³⁷

A5, A5 Quattro

4 cyl. 2.0L Turbo

VO-117

LF⁴⁵⁰

A7 Quattro

V6 3.0 Turbo

LF⁴⁵⁰

A7 Sportback

V6 3.0 Turbo

LF⁴⁵⁰

Se reporter à table de matière pour les notes en bas de page en français. Utilize el contenido para ver notas a pie.

NS - Non-Serviceable / Non réparable / No reparable LF - Life-Time Filter / Filtro para toda la vida / Filtre à vie

⁴³⁷ Requires replacement of the complete fuel pump/fuel filter module. ⁴⁵⁰ Lifetime filter. Does not require replacement under normal conditions.



AUDI (cont'd)

	Oil	Air	Cabin*	Fuel
2019				
Q7				
4 cyl. 2.0L Turbo	VO-117			NS ⁴³⁷
RS3				
4 cyl. 2.5L Turbo	VO-85		VCA-1189	
S3				
4 cyl. 2.0L Turbo	VO-117	VA-453	VCA-1189	NS ⁴³⁷
S4				
6 cyl. 3.0L Supercharged				LF ⁴⁵⁰
TT, TT Quattro				
4 cyl. 2.0L Turbo	VO-117	VA-453	VCA-1189	
5 cyl. 2.5L Turbo	VO-85		VCA-1189	
2018				
A3, A3 Quattro				
4 cyl. 1.4L Turbo (Hybrid)	VO-25		VCA-1189	LF ⁴⁵⁰
4 cyl. 2.0L Turbo	VO-117	VA-453	VCA-1189	LF ⁴⁵⁰
A4 allroad				
4 cyl. 2.0L DI Turbo (CYMC)	VO-117			NS ⁴³⁷
A4, A4 Quattro				
4 cyl. 2.0L Turbo	VO-117			NS ⁴³⁷
A5, A5 Quattro				
4 cyl. 2.0L Turbo	VO-117			LF ⁴⁵⁰
A6, A6 Quattro				
4 cyl. 2.0L Turbo	VO-117			NS ⁴³⁷
V6 3.0L Supercharged	VO-168			NS ⁴³⁷
A7 Quattro				
V6 3.0L Supercharged				LF ⁴⁵⁰
Q3, Q3 Quattro				
4 cyl. 2.0L Turbo	VO-101	VA-274	VCA-1135	NS ⁴³⁷
Q5				
4 cyl. 2.0L Turbo	VO-117			NS ⁴³⁷
Q7				
4 cyl. 2.0L Turbo	VO-117			NS ⁴³⁷
RS3				
4 cyl. 2.5L Turbo	VO-85		VCA-1189	
RS7				
V8 4.0				LF ⁴⁵⁰
R8				
V10 5.2L	VO-138			
S3				
4 cyl. 2.0L Turbo	VO-117	VA-453	VCA-1189	NS ⁴³⁷
S4				
6 cyl. 3.0L Supercharged				LF ⁴⁵⁰
S6				
V8 4.0L Turbo				LF ⁴⁵⁰
S7				
V8 4.0L Turbo				LF ⁴⁵⁰
TT, TT Quattro				
4 cyl. 2.0L Turbo	VO-117	VA-453	VCA-1189	
5 cyl. 2.5L Turbo	VO-85		VCA-1189	
2017				
A3, A3 Quattro				
4 cyl. 1.4L Turbo (Hybrid)	VO-25		VCA-1189	LF ⁴⁵⁰

Se reporter à table de matière pour les notes en bas de page en français. Utilize el contenido para ver notas a pie.

NS - Non-Serviceable / Non réparable / No repairable LF - Life-Time Filter / Filtro para toda la vida / Filtre à vie

⁴³⁷ Requires replacement of the complete fuel pump/fuel filter module. ⁴⁵⁰ Lifetime filter. Does not require replacement under normal conditions.



AUDI (cont'd)

2017

A3, A3 Quattro

4 cyl. 2.0L Turbo	VO-117	VA-453	VCA-1189	LF ⁴⁵⁰
-------------------	--------	--------	----------	-------------------

A4 allroad

4 cyl. 2.0L DI Turbo (CYMC)	VO-117			NS ⁴³⁷
-----------------------------	--------	--	--	-------------------

A4, A4 Quattro

4 cyl. 2.0L Turbo	VO-117			NS ⁴³⁷
-------------------	--------	--	--	-------------------

A5, A5 Quattro

4 cyl. 2.0L Turbo	VO-101	VA-313	VCA-1194	LF ⁴⁵⁰
-------------------	--------	--------	----------	-------------------

A6, A6 Quattro

4 cyl. 2.0L Turbo	VO-117			NS ⁴³⁷
V6 3.0L Supercharged	VO-168			NS ⁴³⁷

A7 Quattro

V6 3.0L Supercharged	VO-168			LF ⁴⁵⁰
----------------------	--------	--	--	-------------------

A8 Quattro

V6 3.0L Supercharged	VO-168			NS ⁴³⁷
----------------------	--------	--	--	-------------------

Q3, Q3 Quattro

4 cyl. 2.0L Turbo	VO-101	VA-274	VCA-1135	NS ⁴³⁷
-------------------	--------	--------	----------	-------------------

Q5

4 cyl. 2.0L Turbo	VO-101	VA-313	VCA-1194	NS
V6 3.0L Supercharged	VO-92	VA-448	VCA-1194	NS

Q7

4 cyl. 2.0L Turbo	VO-117			NS ⁴³⁷
V6 3.0L Supercharged	VO-168			NS ⁴³⁷

RS3

4 cyl. 2.5L Turbo	VO-85		VCA-1189	
-------------------	-------	--	----------	--

RS7

V8 4.0				LF ⁴⁵⁰
--------	--	--	--	-------------------

R8

V10 5.2L	VO-138			
----------	--------	--	--	--

S3

4 cyl. 2.0L Turbo	VO-117	VA-453	VCA-1189	NS ⁴³⁷
-------------------	--------	--------	----------	-------------------

S5

V6 3.0L Supercharged	VO-92	VA-448	VCA-1194	NS ⁴³⁷
----------------------	-------	--------	----------	-------------------

S6

V8 4.0L Turbo				LF ⁴⁵⁰
---------------	--	--	--	-------------------

S7

V8 4.0L Turbo				LF ⁴⁵⁰
---------------	--	--	--	-------------------

SQ5

V6 3.0 Supercharged	VO-92	VA-448	VCA-1194	NS ⁴³⁷
---------------------	-------	--------	----------	-------------------

TT, TT Quattro

4 cyl. 2.0L FI Turbo (CNTC)	VO-117	VA-453	VCA-1189	
4 cyl. 2.0L FI Turbo (CYFB)	VO-117	VA-453	VCA-1189	

2016

A3, A3 Quattro

4 cyl. 1.4L Turbo (Hybrid)	VO-25		VCA-1189	LF ⁴⁵⁰
4 cyl. 1.8L Turbo	VO-117	VA-453	VCA-1189	LF ⁴⁵⁰
4 cyl. 2.0L Diesel Turbo	VO-165	VA-453	VCA-1189	
4 cyl. 2.0L Turbo	VO-117	VA-453	VCA-1189	LF ⁴⁵⁰

A4

4 cyl. 2.0L DI Turbo	VO-101	VA-313	VCA-1194	NS ⁴³⁷
----------------------	--------	--------	----------	-------------------

A4 allroad

4 cyl. 2.0 DI Turbo (CPMB)	VO-101	VA-313	VCA-1194	NS ⁴³⁷
----------------------------	--------	--------	----------	-------------------

Se reporter à table de matière pour les notes en bas de page en français. Utilize el contenido para ver notas a pie.

NS - Non-Serviceable / Non réparable / No repairable LF - Life-Time Filter / Filtro para toda la vida / Filtre à vie

⁴³⁷ Requires replacement of the complete fuel pump/fuel filter module. ⁴⁵⁰ Lifetime filter. Does not require replacement under normal conditions.



AUDI (cont'd)

	Oil	Air	Cabin*	Fuel
2016				
A4 Quattro				
4 cyl. 2.0L Turbo	VO-101	VA-313	VCA-1194	NS ⁴³⁷
A5, A5 Quattro				
4 cyl. 2.0L Turbo	VO-101	VA-313	VCA-1194	LF ⁴⁵⁰
A6, A6 Quattro				
4 cyl. 2.0L Turbo	VO-117			NS ⁴³⁷
V6 3.0L Supercharged	VO-168			NS ⁴³⁷
A7 Quattro				
V6 3.0L Supercharged	VO-168			LF ⁴⁵⁰
A8 Quattro				
V6 3.0L Supercharged	VO-168			NS ⁴³⁷
Allroad				
4 cyl. 2.0L Turbo	VO-101	VA-313	VCA-1194	NS ⁴³⁷
Q3, Q3 Quattro				
4 cyl. 2.0L Turbo	VO-101	VA-274	VCA-1135	NS ⁴³⁷
Q5				
4 cyl. 2.0L Hybrid	VO-101	VA-313	VCA-1194	NS
4 cyl. 2.0L Turbo	VO-101	VA-313	VCA-1194	NS
V6 3.0L Diesel Turbo		VA-448	VCA-1194	
V6 3.0L Supercharged	VO-92	VA-448	VCA-1194	NS
S3				
4 cyl. 2.0L Turbo	VO-117	VA-453	VCA-1189	NS ⁴³⁷
S4				
6 cyl. 3.0L Supercharged	VO-92	VA-448	VCA-1194	LF ⁴⁵⁰
S5				
V6 3.0L Supercharged	VO-92	VA-448	VCA-1194	NS ⁴³⁷
S6				
V8 4.0L Turbo				LF ⁴⁵⁰
S7				
V8 4.0L Turbo				LF ⁴⁵⁰
SQ5				
V6 3.0 Supercharged	VO-92	VA-448	VCA-1194	NS ⁴³⁷
TT, TT Quattro				
4 cyl. 2.0L FI Turbo (CNTC)	VO-117	VA-453	VCA-1189	
4 cyl. 2.0L FI Turbo (CYFB)	VO-117	VA-453	VCA-1189	
2015				
A3, A3 Quattro				
4 cyl. 1.8L Turbo	VO-117	VA-453	VCA-1189	LF ⁴⁵⁰
4 cyl. 2.0L Diesel Turbo	VO-165	VA-453	VCA-1189	
4 cyl. 2.0L Turbo	VO-117	VA-453	VCA-1189	LF ⁴⁵⁰
A4				
4 cyl. 2.0L DI Turbo	VO-101	VA-313	VCA-1194	NS ⁴³⁷
A4 allroad				
4 cyl. 2.0 DI Turbo (CPMB)	VO-101	VA-313	VCA-1194	NS ⁴³⁷
A4 Quattro				
4 cyl. 2.0L Turbo	VO-101	VA-313	VCA-1194	NS ⁴³⁷
A5, A5 Quattro				
4 cyl. 2.0L Turbo	VO-101	VA-313	VCA-1194	LF ⁴⁵⁰
A6, A6 Quattro				
4 cyl. 2.0L Turbo	VO-101			NS ⁴³⁷
V6 3.0L Supercharged	VO-92			NS ⁴³⁷

Se reporter à table de matière pour les notes en bas de page en français. Utilize el contenido para ver notas a pie.

NS - Non-Serviceable / Non réparable / No repairable LF - Life-Time Filter / Filtro para toda la vida / Filtre à vie

⁴³⁷ Requires replacement of the complete fuel pump/fuel filter module. ⁴⁵⁰ Lifetime filter. Does not require replacement under normal conditions.



AUDI (cont'd)

2015

A7 Quattro

V6 3.0L Supercharged	VO-92			LF ⁴⁵⁰
----------------------	-------	--	--	-------------------

A8 Quattro

V6 3.0L Supercharged	VO-168			NS ⁴³⁷
----------------------	--------	--	--	-------------------

Allroad

4 cyl. 2.0L Turbo	VO-101	VA-313	VCA-1194	NS ⁴³⁷
-------------------	--------	--------	----------	-------------------

Q3,Q3 Quattro

4 cyl. 2.0L Turbo	VO-101	VA-274	VCA-1135	NS ⁴³⁷
-------------------	--------	--------	----------	-------------------

Q5

4 cyl. 2.0L Hybrid	VO-101	VA-313	VCA-1194	NS
4 cyl. 2.0L Turbo	VO-101	VA-313	VCA-1194	NS
V6 3.0L Diesel Turbo		VA-448	VCA-1194	
V6 3.0L Supercharged	VO-92	VA-448	VCA-1194	NS

Q7

V6 3.0L Diesel Turbo		VA-204		
V6 3.0L Supercharged	VO-92	VA-204		NS ⁴³⁷

RS5

V8 4.2L	VO-138		VCA-1194	
---------	--------	--	----------	--

R8

V8 4.2L	VO-138			
V10 5.2L	VO-138			

S3

4 cyl. 2.0L Turbo	VO-117	VA-453	VCA-1189	NS ⁴³⁷
-------------------	--------	--------	----------	-------------------

S4

6 cyl 3.0L Supercharged	VO-92	VA-448	VCA-1194	LF ⁴⁵⁰
-------------------------	-------	--------	----------	-------------------

S5

V6 3.0L Supercharged	VO-92	VA-448	VCA-1194	
----------------------	-------	--------	----------	--

S7

V8 4.0L Turbo				LF ⁴⁵⁰
---------------	--	--	--	-------------------

SQ5

V6 3.0 Supercharged	VO-92	VA-448	VCA-1194	NS ⁴³⁷
---------------------	-------	--------	----------	-------------------

TT, TT Quattro

4 cyl 2.0L FI Turbo (CDMA)	VO-85	VA-365	VCA-1135	
4 cyl. 2.0L FI Turbo (CETA)	VO-101	VA-274	VCA-1135	

2014

A4

4 cyl. 2.0L DI Turbo	VO-101	VA-313	VCA-1194	NS ⁴³⁷
----------------------	--------	--------	----------	-------------------

A4 allroad

4 cyl. 2.0 DI Turbo (CPMB)	VO-101	VA-313	VCA-1194	NS ⁴³⁷
----------------------------	--------	--------	----------	-------------------

A4 Quattro

4 cyl. 2.0L Turbo	VO-101	VA-313	VCA-1194	NS ⁴³⁷
-------------------	--------	--------	----------	-------------------

A5, A5 Quattro

4 cyl. 2.0L Turbo	VO-101	VA-313	VCA-1194	LF ⁴⁵⁰
-------------------	--------	--------	----------	-------------------

A6, A6 Quattro

4 cyl 2.0L Turbo	VO-101			NS ⁴³⁷
V6 3.0L Supercharged	VO-92			NS ⁴³⁷

A7 Quattro

V6 3.0L Supercharged	VO-92			LF ⁴⁵⁰
----------------------	-------	--	--	-------------------

A8 Quattro

V6 3.0L Supercharged	VO-92			NS ⁴³⁷
----------------------	-------	--	--	-------------------

Allroad

4 cyl. 2.0L Turbo	VO-101	VA-313	VCA-1194	NS ⁴³⁷
-------------------	--------	--------	----------	-------------------

Se reporter à table de matière pour les notes en bas de page en français. Utilize el contenido para ver notas a pie.

NS - Non-Serviceable / Non réparable / No repairable LF - Life-Time Filter / Filtro para toda la vida / Filtre à vie

⁴³⁷ Requires replacement of the complete fuel pump/fuel filter module. ⁴⁵⁰ Lifetime filter. Does not require replacement under normal conditions.



AUDI (cont'd)

	Oil	Air	Cabin*	Fuel
2014				
Q5				
4 cyl. 2.0L Hybrid	VO-101	VA-313	VCA-1194	NS
4 cyl. 2.0L Turbo	VO-101	VA-313	VCA-1194	NS
V6 3.0L Diesel Turbo		VA-448	VCA-1194	
V6 3.0L Supercharged	VO-92	VA-448	VCA-1194	NS
Q7				
V6 3.0L Diesel Turbo		VA-204		
V6 3.0L Supercharged	VO-92	VA-204		NS ⁴³⁷
RS5				
V8 4.2L	VO-138		VCA-1194	
RS7				
V8 4.0				LF ⁴⁵⁰
R8				
V8 4.2L	VO-138			
V10 5.2L	VO-138			
S4				
6 cyl. 3.0L Supercharged	VO-92	VA-448	VCA-1194	LF ⁴⁵⁰
S5				
V6 3.0L Supercharged	VO-92	VA-448	VCA-1194	NS ⁴³⁷
S7				
V8 4.0L Turbo				LF ⁴⁵⁰
SQ5				
V6 3.0 Supercharged	VO-92	VA-448	VCA-1194	NS ⁴³⁷
TT, TT Quattro				
4 cyl. 2.0L FI Turbo (CDMA)	VO-85	VA-365	VCA-1135	
4 cyl. 2.0L FI Turbo (CETA)	VO-101	VA-274	VCA-1135	
2013				
A3, A3 Quattro				
4 cyl. 2.0L Gas Turbo	VO-101	VA-274	VCA-1135	
4 cyl. 2.0L Diesel Turbo	VO-77	VA-274	VCA-1135	
A4				
4 cyl. 2.0L DI Turbo (CAEB)	VO-101	VA-313	VCA-1194	NS ⁴³⁷
A4 allroad				
4 cyl. 2.0 DI Turbo (CAEB, CPMA)	VO-101	VA-313	VCA-1194	NS ⁴³⁷
A4 Quattro				
4 cyl. 2.0L Turbo	VO-101	VA-313	VCA-1194	NS ⁴³⁷
A5, A5 Quattro				
4 cyl. 2.0L Turbo	VO-101	VA-313	VCA-1194	LF ⁴⁵⁰
A6, A6 Quattro				
4 cyl. 2.0L Turbo	VO-101			NS ⁴³⁷
V6 3.0L Supercharged	VO-92			NS ⁴³⁷
A7 Quattro				
V6 3.0L Supercharged	VO-92			LF ⁴⁵⁰
A8 Quattro				
V6 3.0L Supercharged	VO-92			NS ⁴³⁷
Allroad				
4 cyl. 2.0L Turbo	VO-101	VA-313	VCA-1194	NS ⁴³⁷
Q5				
4 cyl. 2.0L Hybrid	VO-101	VA-313	VCA-1194	NS
4 cyl. 2.0L Turbo	VO-101	VA-313	VCA-1194	NS
V6 3.0L Supercharged	VO-92	VA-448	VCA-1194	NS

Se reporter à table de matière pour les notes en bas de page en français. Utilize el contenido para ver notas a pie.

NS - Non-Serviceable / Non réparable / No reparable LF - Life-Time Filter / Filtro para toda la vida / Filtre à vie

⁴³⁷ Requires replacement of the complete fuel pump/fuel filter module. ⁴⁵⁰ Lifetime filter. Does not require replacement under normal conditions.



AUDI (cont'd)

2013

Q7

V6 3.0L Diesel Turbo		VA-204		
V6 3.0L Supercharged	VO-92	VA-204		NS ⁴³⁷

RS5

V8 4.2L	VO-138		VCA-1194	
---------	--------	--	----------	--

S4

6 cyl 3.0L Supercharged	VO-92	VA-448	VCA-1194	LF ⁴⁵⁰
-------------------------	-------	--------	----------	-------------------

S5

V6 3.0L Supercharged	VO-92	VA-448	VCA-1194	NS ⁴³⁷
----------------------	-------	--------	----------	-------------------

S7

V8 4.0L Turbo				LF ⁴⁵⁰
---------------	--	--	--	-------------------

TT, TT Quattro

4 cyl 2.0L FI Turbo (CDMA)	VO-85	VA-365	VCA-1135	
4 cyl. 2.0L FI Turbo (CETA)	VO-101	VA-274	VCA-1135	
5 cyl. 2.5L Turbo	VO-85	VA-365	VCA-1135	

2012

A3, A3 Quattro

4 cyl 2.0L Turbo	VO-101	VA-274	VCA-1135	
4 cyl. 2.0L Diesel Turbo	VO-77	VA-274	VCA-1135	

A4

4 cyl. 2.0L DI Turbo (CAEB)	VO-101	VA-313	VCA-1194	NS ⁴³⁷
-----------------------------	--------	--------	----------	-------------------

A4 Quattro

4 cyl. 2.0L Turbo	VO-101	VA-313	VCA-1194	NS ⁴³⁷
-------------------	--------	--------	----------	-------------------

A5, A5 Quattro

4 cyl. 2.0L Turbo	VO-101	VA-313	VCA-1194	LF ⁴⁵⁰
-------------------	--------	--------	----------	-------------------

A6, A6 Quattro

4 cyl 2.0L Turbo	VO-101			NS ⁴³⁷
V6 3.0L Supercharged	VO-92			NS ⁴³⁷

A7 Quattro

V6 3.0L Supercharged	VO-92			LF ⁴⁵⁰
----------------------	-------	--	--	-------------------

A8 Quattro

V8 4.2L DI (CDRA)	VO-138			
-------------------	--------	--	--	--

Q5

4 cyl. 2.0L DI Turbo (CAEB)	VO-101	VA-313	VCA-1194	NS ⁴³⁷
V6 3.2L DI (CALB)	VO-92	VA-448	VCA-1194	NS ⁴³⁷

Q7

V6 3.0L Diesel Turbo		VA-204		
V6 3.0L Supercharged	VO-92	VA-204		NS ⁴³⁷

R8

V8 4.2L DI (CNDA)	VO-138			
V10 5.2L DI	VO-138			

S4

6 cyl 3.0L Supercharged	VO-92	VA-448	VCA-1194	LF ⁴⁵⁰
-------------------------	-------	--------	----------	-------------------

S5

V6 3.0L Supercharged	VO-92	VA-448	VCA-1194	NS ⁴³⁷
V8 4.2L	VO-138	VA-448	VCA-1194	NS ⁴³⁷

TT, TT Quattro

4 cyl 2.0L FI Turbo (CDMA)	VO-85	VA-365	VCA-1135	
4 cyl. 2.0L FI Turbo (CETA)	VO-101	VA-274	VCA-1135	
5 cyl. 2.5L FI Turbo	VO-85	VA-365	VCA-1135	

Se reporter à table de matière pour les notes en bas de page en français. Utilize el contenido para ver notas a pie.

NS - Non-Serviceable / Non réparable / No reparable LF - Life-Time Filter / Filtro para toda la vida / Filtre à vie

⁴³⁷ Requires replacement of the complete fuel pump/fuel filter module. ⁴⁵⁰ Lifetime filter. Does not require replacement under normal conditions.



AUDI (cont'd)

	Oil	Air	Cabin*	Fuel
2011				
A3, A3 Quattro				
4 cyl. 2.0L Turbo	VO-101	VA-274	VCA-1135	
4 cyl. 2.0L DI Turbo Diesel	VO-77	VA-274	VCA-1135	
A4, A4 Quattro				
4 cyl. 2.0L Turbo	VO-101	VA-313	VCA-1194	NS ⁴³⁷
A5, A5 Quattro				
4 cyl. 2.0L Turbo	VO-101	VA-313	VCA-1194	LF ⁴⁵⁰
A6, A6 Quattro				
V6 3.0L DI (S.C.)	VO-92	VA-329		
V6 3.2L DI (CALA)	VO-92	VA-329		
V8 4.2L FI (BVJ)	VO-138	VA-329		
A8 Quattro				
V8 4.2L DI (CDRA)	VO-138			
Q5				
4 cyl. 2.0L DI Turbo (CAEB)	VO-101	VA-313	VCA-1194	NS ⁴³⁷
V6 3.2L DI (CALB)	VO-92	VA-448	VCA-1194	NS ⁴³⁷
Q7				
V6 3.0L DI Turbo Diesel		VA-204		
V6 3.0L Supercharged	VO-92	VA-204		NS ⁴³⁷
R8				
V8 4.2L DI (CNDA)	VO-138			
V10 5.2L DI	VO-138			
S4				
6 cyl. 3.0L Supercharged	VO-92	VA-448	VCA-1194	LF ⁴⁵⁰
S5				
6 cyl. 3.0L Supercharged	VO-92	VA-448	VCA-1194	LF ⁴⁵⁰
V8 4.2L	VO-138	VA-448	VCA-1194	LF ⁴⁵⁰
S6				
V10 5.2L FI (BXA)	VO-138			
TT, TT Quattro				
4 cyl. 2.0L FI Turbo (CDMA)	VO-85	VA-365	VCA-1135	
4 cyl. 2.0L FI Turbo (CETA)	VO-101	VA-274	VCA-1135	
2010				
A3, A3 Quattro				
4 cyl. 2.0L DI Turbo (CBFA)	VO-101	VA-274	VCA-1135	
4 cyl. 2.0L DI Turbo (CCTA)	VO-101	VA-274	VCA-1135	
4 cyl. 2.0L DI Turbo Diesel	VO-77	VA-274	VCA-1135	
A4, A4 Quattro				
4 cyl. 2.0L DI Turbo (CAEB)	VO-101	VA-313	VCA-1194	NS ⁴³⁷
A5, A5 Quattro				
4 cyl. 2.0L Turbo	VO-101	VA-313	VCA-1194	LF ⁴⁵⁰
A5 Quattro				
V6 3.2L	VO-92	VA-448	VCA-1194	
A6, A6 Quattro				
V6 3.0L DI (S.C.)	VO-92	VA-329		
V6 3.2L DI (CALA)	VO-92	VA-329		
V8 4.2L FI (BVJ)	VO-138	VA-329		
A8 Quattro				
V8 4.2L FI (BVJ)	VO-138			
Q5				
4 cyl. 2.0L DI Turbo (CAEB)	VO-101	VA-313	VCA-1194	NS ⁴³⁷
V6 3.2L DI (CALB)	VO-92	VA-448	VCA-1194	NS ⁴³⁷

Se reporter à table de matière pour les notes en bas de page en français. Utilize el contenido para ver notas a pie.

NS - Non-Serviceable / Non réparable / No reparable LF - Life-Time Filter / Filtro para toda la vida / Filtre à vie

⁴³⁷ Requires replacement of the complete fuel pump/fuel filter module. ⁴⁵⁰ Lifetime filter. Does not require replacement under normal conditions.



AUDI (cont'd)

2010

Q7

V6 3.0L DI Turbo Diesel		VA-204		
V6 3.6L DI (BHK)	VO-150	VA-204		NS ⁴³⁷
V8 4.2L DI (BAR)	VO-138	VA-204 ¹¹²		NS ⁴³⁷

R8

V8 4.2L FI (BYH)	VO-138			
V10 5.2L DI	VO-138			

S4

6 cyl 3.0L Supercharged	VO-92	VA-448	VCA-1194	LF ⁴⁵⁰
-------------------------	-------	--------	----------	-------------------

S5

6 cyl 3.0L Supercharged	VO-92	VA-448	VCA-1194	LF ⁴⁵⁰
V8 4.2L FI (CAUA)	VO-138	VA-448	VCA-1194	LF ⁴⁵⁰

S6

V10 5.2L FI (BXA)	VO-138			
-------------------	--------	--	--	--

TT, TT Quattro

4 cyl 2.0L FI Turbo (CDMA)	VO-85	VA-365	VCA-1135	
4 cyl. 2.0L DI Turbo (CCTA)	VO-101	VA-274	VCA-1135	

2009

A3, A3 Quattro

4 cyl 2.0L DI Turbo (CCTA, CBFA)	VO-101	VA-274	VCA-1135	
V6 3.2L DI (CBRA)	VO-77	VA-365	VCA-1135	

A4 Cabriolet

4 cyl. 2.0L DI Turbo (BWT)	VO-85	VA-325	VCA-1124	
V6 3.2L DI (BKH)	VO-92	VA-325	VCA-1124	

A4, A4 Quattro

4 cyl. 2.0L DI Turbo (BWT)	VO-85	VA-325	VCA-1124	
4 cyl. 2.0L DI Turbo (CAEB)	VO-101	VA-313	VCA-1194	NS ⁴³⁷
V6 3.2L DI (CALA)	VO-92	VA-448	VCA-1194	NS ⁴³⁷

A5 Quattro

V6 3.2L	VO-92	VA-448	VCA-1194	
---------	-------	--------	----------	--

A6, A6 Quattro

V6 3.0L FI (S.C.)	VO-92	VA-329		
V6 3.2L DI (BHK)	VO-92	VA-329		
V8 4.2L FI (BVJ)	VO-138	VA-329		

A8 Quattro

V8 4.2L FI (BVJ)	VO-138			
------------------	--------	--	--	--

Q5

V6 3.2L FI	VO-92	VA-448	VCA-1194	NS ⁴³⁷
------------	-------	--------	----------	-------------------

Q7

V6 3.0L DI Turbo Diesel		VA-204		
V6 3.6L DI (BHK)	VO-150	VA-204		NS ⁴³⁷
V8 4.2L DI (BAR)	VO-138	VA-204 ¹¹²		NS ⁴³⁷

R8

V8 4.2L FI (BYH)	VO-138			
------------------	--------	--	--	--

S4

V8 4.2L FI (BHF)	VO-94		VCA-1124	
------------------	-------	--	----------	--

S5

V8 4.2L FI (CAUA)	VO-138	VA-448	VCA-1194	LF ⁴⁵⁰
-------------------	--------	--------	----------	-------------------

S6

V10 5.2L FI (BXA)	VO-138			
-------------------	--------	--	--	--

S8

V10 5.2L DI (BSM)	VO-138			
-------------------	--------	--	--	--

Se reporter à table de matière pour les notes en bas de page en français. Utilize el contenido para ver notas a pie.

NS - Non-Serviceable / Non réparable / No reparable LF - Life-Time Filter / Filtro para toda la vida / Filtre à vie

¹¹² Requires two (2). ⁴³⁷ Requires replacement of the complete fuel pump/fuel filter module. ⁴⁵⁰ Lifetime filter. Does not require replacement under normal conditions.



AUDI (cont'd)

	Oil	Air	Cabin*	Fuel
2009				
TT, TT Quattro				
4 cyl. 2.0L FI Turbo (CDMA)	VO-85	VA-365	VCA-1135	
4 cyl. 2.0L DI Turbo (BPY)	VO-85	VA-318	VCA-1135	
4 cyl. 2.0L DI Turbo (CCTA)	VO-101	VA-274	VCA-1135	
V6 3.2L DI (CBRA)	VO-77	VA-365	VCA-1135	
2008				
A3, A3 Quattro				
4 cyl. 2.0L DI Turbo (BPY)	VO-85	VA-318	VCA-1135	
4 cyl. 2.0L DI Turbo (CCTA)	VO-101	VA-274	VCA-1135	
V6 3.2L DI (CBRA)	VO-77	VA-365	VCA-1135	
A4, A4 Quattro				
4 cyl. 2.0L DI Turbo (BWT)	VO-85	VA-325	VCA-1124	
V6 3.2L DI (BKH)	VO-92	VA-325	VCA-1124	
A5 Quattro				
V6 3.2L	VO-92	VA-448	VCA-1194	
A6, A6 Quattro				
V6 3.2L DI (BKH)	VO-92	VA-329		
V8 4.2L FI (BVJ)	VO-138	VA-329		
A8 Quattro				
V8 4.2L FI (BVJ)	VO-138			
Q7				
V6 3.6L DI (BHK)	VO-150	VA-204		NS ⁴³⁷
V8 4.2L DI (BAR)	VO-138	VA-204 ¹¹²		NS ⁴³⁷
RS4				
V8 4.2L	VO-138		VCA-1124	
R8				
V8 4.2L FI (BYH)	VO-138			
S4				
V8 4.2L FI (BHF)	VO-94		VCA-1124	
S5				
V8 4.2L FI (CAUA)	VO-138	VA-448	VCA-1194	LF ⁴⁵⁰
S6				
V10 5.2L FI (BXA)	VO-138			
S8				
V10 5.2L DI (BSM)	VO-138			
TT, TT Quattro				
4 cyl. 2.0L DI Turbo (BPY)	VO-85	VA-318	VCA-1135	
V6 3.2L DI (CBRA)	VO-77	VA-365	VCA-1135	
2007				
A3, A3 Quattro				
4 cyl. 2.0L DI Turbo (BPY)	VO-85	VA-318	VCA-1135	
V6 3.2L DI (BUB)	VO-77	VA-365	VCA-1135	
A4, A4 Quattro				
4 cyl. 2.0L DI Turbo (BWT)	VO-85	VA-325	VCA-1124	
V6 3.2L DI (BKH)	VO-92	VA-325	VCA-1124	
A6, A6 Quattro				
V6 3.2L DI (BKH)	VO-92	VA-329		
V8 4.2L FI (BVJ)	VO-138	VA-329		
A8 Quattro				
V8 4.2L FI (BVJ)	VO-138			
Q7				
V6 3.6L DI (BHK)	VO-150	VA-204		NS ⁴³⁷

Se reporter à table de matière pour les notes en bas de page en français. Utilize el contenido para ver notas a pie.

NS - Non-Serviceable / Non réparable / No repairable LF - Life-Time Filter / Filtro para toda la vida / Filtre à vie

¹¹² Requires two (2). ⁴³⁷ Requires replacement of the complete fuel pump/fuel filter module. ⁴⁵⁰ Lifetime filter. Does not require replacement under normal conditions.



AUDI (cont'd)

2007

Q7

V8 4.2L DI (BAR)	VO-138	VA-204 ¹¹²		NS ⁴³⁷
------------------	--------	-----------------------	--	-------------------

RS4

V8 4.2L	VO-138		VCA-1124	
---------	--------	--	----------	--

S4

V8 4.2L FI (BHF)	VO-94		VCA-1124	
------------------	-------	--	----------	--

S6

V10 5.2L FI (BXA)	VO-138			
-------------------	--------	--	--	--

S8

V10 5.2L DI (BSM)	VO-138			
-------------------	--------	--	--	--

2006

A3, A3 Quattro

4 cyl. 2.0L DI Turbo (BPY)	VO-85	VA-318	VCA-1135	
----------------------------	-------	--------	----------	--

V6 3.2L DI (BUB)	VO-77	VA-365	VCA-1135	
------------------	-------	--------	----------	--

A4 Cabriolet

4 cyl. 1.8L FI Turbo (AMB)	VO-15	VA-325	VCA-1124	
----------------------------	-------	--------	----------	--

V6 3.0L FI (BGN)	VO-93	VA-325	VCA-1124	
------------------	-------	--------	----------	--

A4, A4 Quattro

4 cyl. 1.8L FI Turbo (AMB)	VO-15	VA-325	VCA-1124	
----------------------------	-------	--------	----------	--

4 cyl. 2.0L DI Turbo (BPG)	VO-85	VA-325	VCA-1124	
----------------------------	-------	--------	----------	--

V6 3.2L DI (BKH)	VO-92	VA-325	VCA-1124	
------------------	-------	--------	----------	--

A6, A6 Quattro

V6 3.2L DI (BKH)	VO-92	VA-329		
------------------	-------	--------	--	--

V8 4.2L FI (BNK)	VO-94	VA-329		
------------------	-------	--------	--	--

A8 Quattro

V8 4.2L FI (BGK)	VO-94			
------------------	-------	--	--	--

S4

V8 4.2L FI (BHF)	VO-94		VCA-1124	
------------------	-------	--	----------	--

TT, TT Quattro

4 cyl. 1.8L FI Turbo	VO-15	VA-138	VCA-1026	
----------------------	-------	--------	----------	--

V6 3.2L FI (BHE)	VO-77	VA-138	VCA-1026	
------------------	-------	--------	----------	--

2005

A4, A4 Quattro

4 cyl. 1.8L FI Turbo (AMB)	VO-15	VA-325	VCA-1124	
----------------------------	-------	--------	----------	--

4 cyl. 2.0L Turbo	VO-85	VA-325	VCA-1124	
-------------------	-------	--------	----------	--

V6 3.0L FI (BGN)	VO-93	VA-325	VCA-1124	
------------------	-------	--------	----------	--

V6 3.2L DI (BKH)	VO-92	VA-325	VCA-1124	
------------------	-------	--------	----------	--

A6, A6 Quattro

V6 3.2L DI (AUK)	VO-92	VA-329		
------------------	-------	--------	--	--

V8 4.2L FI (BAT)	VO-94	VA-329		
------------------	-------	--------	--	--

A8 Quattro

V8 4.2L FI (BFM)	VO-94			
------------------	-------	--	--	--

Allroad

V6 2.7L FI Turbo	VO-93	VA-157	VCA-1124	
------------------	-------	--------	----------	--

V8 4.2L FI (BAS)	VO-94	VA-157	VCA-1124	
------------------	-------	--------	----------	--

S4

V8 4.2L FI (BHF)	VO-94		VCA-1124	
------------------	-------	--	----------	--

TT, TT Quattro

4 cyl. 1.8L Turbo FI (AWP)(BEA)	VO-15	VA-138	VCA-1026	
---------------------------------	-------	--------	----------	--

V6 3.2L FI (BHE)	VO-77	VA-138	VCA-1026	
------------------	-------	--------	----------	--

Se reporter à table de matière pour les notes en bas de page en français. Utilize el contenido para ver notas a pie.

NS - Non-Serviceable / Non réparable / No reparable LF - Life-Time Filter / Filtro para toda la vida / Filtre à vie

¹¹² Requires two (2). ⁴³⁷ Requires replacement of the complete fuel pump/fuel filter module.



AUDI (cont'd)

	Oil	Air	Cabin*	Fuel
2004				
A4, A4 Quattro				
4 cyl. 1.8L FI Turbo (AMB)	VO-15	VA-325	VCA-1124	
V6 3.0L FI (AVK)	VO-93	VA-325	VCA-1124	
A6, A6 Quattro				
V6 2.7L FI Turbo	VO-93	VA-157	VCA-1124	
V6 3.0L FI (AVK)	VO-93	VA-157	VCA-1124	
V8 4.2L FI (AWN)	VO-143	VA-157	VCA-1124	
A8 Quattro				
V8 4.2L FI (BFM)	VO-94			
Allroad				
V6 2.7L FI Turbo	VO-93	VA-157	VCA-1124	
V8 4.2L FI (BAS)	VO-94	VA-157	VCA-1124	
RS6				
V8 4.2L Turbo	VO-15		VCA-1124	
S4				
V8 4.2L FI (BHF)	VO-94		VCA-1124	
TT, TT Quattro				
4 cyl. 1.8L FI Turbo	VO-15	VA-138	VCA-1026	
V6 3.2L FI (BHE)	VO-77	VA-138	VCA-1026	
2003				
A4, A4 Quattro				
4 cyl. 1.8L FI Turbo	VO-15	VA-325	VCA-1124	
V6 3.0L FI	VO-93	VA-325	VCA-1124	
A6, A6 Quattro				
V6 2.7L FI Turbo	VO-93	VA-157	VCA-1124	
V6 3.0L FI	VO-93	VA-157	VCA-1124	
V8 4.2L FI	VO-143	VA-157	VCA-1124	
A8, S8				
V8 4.2L FI	VO-150			
Allroad				
V6 2.7L FI Turbo	VO-93	VA-157	VCA-1124	
V8 4.2L FI (BAS)	VO-94	VA-157	VCA-1124	
RS6				
V8 4.2L Turbo	VO-15		VCA-1124	
S6				
V8 4.2L FI	VO-143	VA-157	VCA-1124	
TT, TT Quattro				
4 cyl. 1.8L FI Turbo	VO-15	VA-138	VCA-1026	
2002				
A4, A4 Quattro				
4 cyl. 1.8L FI Turbo	VO-15	VA-325	VCA-1124	
V6 3.0L FI	VO-93	VA-325	VCA-1124	
A6, A6 Quattro				
V6 2.7L FI Turbo	VO-93	VA-157	VCA-1124	
V6 3.0L FI	VO-93	VA-157	VCA-1124	
V8 4.2L FI	VO-143	VA-157	VCA-1124	
A8, S8				
V8 4.2L FI	VO-150			
Allroad				
V6 2.7L FI Turbo	VO-93	VA-157	VCA-1124	
S4				
V6 2.7L FI Turbo	VO-93	VA-157		

Se reporter à table de matière pour les notes en bas de page en français. Utilize el contenido para ver notas a pie.

NS - Non-Serviceable / Non réparable / No repairable LF - Life-Time Filter / Filtro para toda la vida / Filtre à vie



AUDI (cont'd)

2002

S6

V8 4.2L FI	VO-143	VA-157	VCA-1124	
------------	--------	--------	----------	--

TT, TT Quattro

4 cyl. 1.8L FI Turbo	VO-15	VA-138	VCA-1026	
----------------------	-------	--------	----------	--

2001

A4, A4 Quattro

4 cyl. 1.8L FI Turbo	VO-15	VA-157		
----------------------	-------	--------	--	--

V6 2.8L FI	VO-93	VA-157		
------------	-------	--------	--	--

A6, A6 Quattro

V6 2.7L FI Turbo	VO-93	VA-157	VCA-1124	
------------------	-------	--------	----------	--

V6 2.8L FI	VO-93	VA-157	VCA-1124	
------------	-------	--------	----------	--

V8 4.2L FI	VO-143	VA-157	VCA-1124	
------------	--------	--------	----------	--

A8, S8

V8 4.2L FI	VO-150			
------------	--------	--	--	--

Allroad

V6 2.7L FI Turbo	VO-93	VA-157	VCA-1124	
------------------	-------	--------	----------	--

S4

V6 2.7L FI Turbo	VO-93	VA-157		
------------------	-------	--------	--	--

TT, TT Quattro

4 cyl. 1.8L FI Turbo	VO-15	VA-138	VCA-1026	
----------------------	-------	--------	----------	--

2000

A4, A4 Quattro

4 cyl. 1.8L FI Turbo	VO-15	VA-157		
----------------------	-------	--------	--	--

V6 2.8L FI	VO-93	VA-157		
------------	-------	--------	--	--

A6, A6 Quattro

V6 2.7L FI Turbo	VO-93	VA-157	VCA-1123	
------------------	-------	--------	----------	--

V6 2.8L FI	VO-93	VA-157	VCA-1123	
------------	-------	--------	----------	--

V8 4.2L FI	VO-143	VA-157	VCA-1123	
------------	--------	--------	----------	--

A8, A8 Quattro

V8 4.2L FI	VO-150			
------------	--------	--	--	--

S4

V6 2.7L FI Turbo	VO-93	VA-157		
------------------	-------	--------	--	--

TT, TT Quattro

4 cyl. 1.8L FI Turbo	VO-15	VA-138	VCA-1026	
----------------------	-------	--------	----------	--

1999

A4, A4 Quattro

4 cyl. 1.8L FI Turbo	VO-15	VA-157		
----------------------	-------	--------	--	--

V6 2.8L FI	VO-93	VA-157		
------------	-------	--------	--	--

A6, A6 Quattro

V6 2.8L FI	VO-93	VA-157	VCA-1123	
------------	-------	--------	----------	--

A8, A8 Quattro

V8 3.7L FI	VO-119			
------------	--------	--	--	--

V8 4.2L FI	VO-119			
------------	--------	--	--	--

1998

A4

4 cyl. 1.8L FI Turbo	VO-15	VA-157		
----------------------	-------	--------	--	--

V6 2.8L FI	VO-15	VA-157		
------------	-------	--------	--	--

A4 Quattro

4 cyl. 1.8L FI Turbo	VO-15	VA-157		
----------------------	-------	--------	--	--

V6 2.8L FI	VO-15	VA-157		
------------	-------	--------	--	--

A6, A6 Quattro

V6 2.8L FI	VO-15	VA-157	VCA-1123	
------------	-------	--------	----------	--

Se reporter à table de matière pour les notes en bas de page en français. Utilize el contenido para ver notas a pie.

NS - Non-Serviceable / Non réparable / No repairable LF - Life-Time Filter / Filtro para toda la vida / Filtre à vie



AUDI (cont'd)

	Oil	Air	Cabin*	Fuel
1998				
A8, A8 Quattro				
V8 3.7L FI	VO-119			
V8 4.2L FI	VO-119			
Cabriolet				
V6 2.8L FI	VO-93			
1997				
A4				
4 cyl. 1.8L FI Turbo	VO-15	VA-157		
V6 2.8L FI	VO-15	VA-157		
A4 Quattro				
4 cyl. 1.8L FI Turbo	VO-15	VA-157		
V6 2.8L FI	VO-15	VA-157		
A6				
V6 2.8L FI	VO-15			
A6 Quattro				
V6 2.8L FI	VO-15			
A8, A8 Quattro				
V8 3.7L FI	VO-119			
V8 4.2L FI	VO-119			
Cabriolet				
V6 2.8L FI	VO-93			
S6				
5 cyl. 2.2L FI Turbo	VO-15			
1996				
A4				
V6 2.8L FI	VO-15	VA-157		
A4 Quattro				
V6 2.8L FI	VO-15	VA-157		
A6				
V6 2.8L FI	VO-15			
A6 Quattro				
V6 2.8L FI	VO-15			
Cabriolet				
V6 2.8L FI	VO-15			
S6				
5 cyl. 2.2L FI Turbo	VO-15			
1995				
90-90 Quattro				
V6 2.8L FI	VO-15			
A6				
V6 2.8L FI	VO-15			
A6 Quattro				
V6 2.8L FI	VO-15			
Cabriolet				
V6 2.8L FI	VO-15			
S6				
5 cyl. 2.2L FI Turbo	VO-15			

Se reporter à table de matière pour les notes en bas de page en français. Utilize el contenido para ver notas a pie.
 NS - Non-Serviceable / Non réparable / No reparable LF - Life-Time Filter / Filtro para toda la vida / Filtre à vie



BENTLEY

2011

Azure

V8 6.8L FI Turbo	VO-86			
------------------	-------	--	--	--

2010

Azure

V8 6.8L FI Turbo	VO-86			
------------------	-------	--	--	--

2009

Arnage

V8 6.8L FI Turbo	VO-86			
------------------	-------	--	--	--

Azure

V8 6.8L FI Turbo	VO-86			
------------------	-------	--	--	--

2008

Arnage

V8 6.8L FI Turbo	VO-86			
------------------	-------	--	--	--

Azure

V8 6.8L FI Turbo	VO-86			
------------------	-------	--	--	--

2007

Arnage

V8 6.8L FI Turbo	VO-86			
------------------	-------	--	--	--

Azure

V8 6.8L FI Turbo	VO-86			
------------------	-------	--	--	--

2006

Arnage

V8 6.8L FI Turbo	VO-86			
------------------	-------	--	--	--

Azure

V8 6.8L FI Turbo	VO-86			
------------------	-------	--	--	--

2005

Arnage

V8 6.8L FI Turbo	VO-86			
------------------	-------	--	--	--

2004

Arnage

V8 6.8L FI Turbo	VO-86			
------------------	-------	--	--	--

2003

Arnage

V8 6.8L FI Turbo	VO-86			
------------------	-------	--	--	--

Azure

V8 6.8L FI Turbo	VO-86			
------------------	-------	--	--	--

2002

Arnage

V8 6.8L FI Turbo	VO-86			
------------------	-------	--	--	--

Azure

V8 6.8L FI Turbo	VO-86			
------------------	-------	--	--	--

Continental

V8 6.8L FI Turbo	VO-86			
------------------	-------	--	--	--

2001

Arnage

V8 4.4L FI Turbo	VO-74			
------------------	-------	--	--	--

V8 6.8L FI Turbo	VO-86			
------------------	-------	--	--	--

Azure

V8 6.8L FI Turbo	VO-86			
------------------	-------	--	--	--

Continental

V8 6.8L FI Turbo	VO-86			
------------------	-------	--	--	--

Se reporter à table de matière pour les notes en bas de page en français. Utilize el contenido para ver notas a pie.

NS - Non-Serviceable / Non réparable / No repairable LF - Life-Time Filter / Filtro para toda la vida / Filtre à vie



BENTLEY (cont'd)

	Oil	Air	Cabin*	Fuel
2000				
Arnage				
V8 4.4L FI Turbo	VO-74			
V8 6.8L FI Turbo	VO-86			
Azure				
V8 6.8L FI Turbo	VO-86			
Continental				
V8 6.8L FI Turbo	VO-86			
1999				
Arnage				
V8 4.4L FI Turbo	VO-74			
Azure				
V8 6.8L FI Turbo	VO-86			
Continental				
V8 6.8L FI Turbo	VO-86			
1998				
Brooklands				
V8 6.8L FI Turbo	VO-86			
Azure				
V8 6.8L FI Turbo	VO-86			
Turbo R				
V8 6.8L FI Turbo	VO-86			
Continental				
V8 6.8L FI Turbo	VO-86			
1997				
Brooklands				
V8 6.8L FI Turbo	VO-86			
Azure				
V8 6.8L FI Turbo	VO-86			
Turbo R				
V8 6.8L FI Turbo	VO-86			
Continental				
V8 6.8L FI Turbo	VO-86			
1996				
Brooklands				
V8 6.8L FI	VO-86			
Azure				
V8 6.8L FI Turbo	VO-86			
Turbo R				
V8 6.8L FI Turbo	VO-86			
Continental				
V8 6.8L FI Turbo	VO-86			
1995				
Brooklands				
V8 6.8L FI	VO-86			
Turbo R				
V8 6.8L FI Turbo	VO-86			
Continental				
V8 6.8L FI Turbo	VO-86			
1994				
Brooklands				
V8 6.8L FI	VO-86			

Se reporter à table de matière pour les notes en bas de page en français. Utilize el contenido para ver notas a pie.

NS - Non-Serviceable / Non réparable / No reparable LF - Life-Time Filter / Filtro para toda la vida / Filtre à vie



BENTLEY (cont'd)

1994

Turbo R

V8 6.8L FI Turbo	VO-86			
------------------	-------	--	--	--

Continental

V8 6.8L FI Turbo	VO-86			
------------------	-------	--	--	--

1993

Brooklands

V8 6.8L FI	VO-86			
------------	-------	--	--	--

Turbo R

V8 6.8L FI Turbo	VO-86			
------------------	-------	--	--	--

Continental

V8 6.8L FI Turbo	VO-86			
------------------	-------	--	--	--

1992

Turbo R

V8 6.8L FI Turbo	VO-86			
------------------	-------	--	--	--

1991

Turbo R

V8 6.8L FI Turbo	VO-86			
------------------	-------	--	--	--

1990

Turbo R

V8 6.8L FI Turbo	VO-86			
------------------	-------	--	--	--

BMW

2019

230i, 230i xDrive

4 cyl. 2.0L Turbo		VA-488		
-------------------	--	--------	--	--

330i, 330i xDrive

4 cyl. 2.0L Turbo		VA-488		LF ⁴⁵⁰
-------------------	--	--------	--	-------------------

340i, 340i xDrive

4 cyl. 3.0L Turbo	VO-169	VA-488		LF ⁴⁵⁰
-------------------	--------	--------	--	-------------------

430i, 430i xDrive

4 cyl. 2.0L Turbo		VA-488		LF ⁴⁵⁰
-------------------	--	--------	--	-------------------

440i, 440i xDrive

6 cyl. 3.0L Turbo	VO-169	VA-488		LF ⁴⁵⁰
-------------------	--------	--------	--	-------------------

540d xDrive

L6 3.0L	VO-169			
---------	--------	--	--	--

540i, 540i xDrive

6 cyl. 3.0 Turbo	VO-169			LF ⁴⁵⁰
------------------	--------	--	--	-------------------

640i, 640i xDrive

6 cyl. 3.0L Turbo	VO-91	VA-444		LF ⁴⁵⁰
-------------------	-------	--------	--	-------------------

650i, 650i xDrive

V8 4.4L Turbo	VO-131			LF ⁴⁵⁰
---------------	--------	--	--	-------------------

740e xDrive

4 cyl. 2.0 Turbo				LF ⁴⁵⁰
------------------	--	--	--	-------------------

740i, 740Li

6 cyl. 3.0L Turbo	VO-169			NS ⁴³⁷
-------------------	--------	--	--	-------------------

750i, 750i xDrive, 750Li, 750Li xDrive

V8 4.4L Turbo	VO-131			NS ⁴³⁷
---------------	--------	--	--	-------------------

Alpina B6 Gran Coupe

V8 4.4 Turbo	VO-131			NS ⁴³⁷
--------------	--------	--	--	-------------------

Alpina B7

V8 4.4L Turbo	VO-131			NS ⁴³⁷
---------------	--------	--	--	-------------------

Se reporter à table de matière pour les notes en bas de page en français. Utilize el contenido para ver notas a pie.

NS - Non-Serviceable / Non réparable / No reparable LF - Life-Time Filter / Filtro para toda la vida / Filtre à vie

⁴³⁷ Requires replacement of the complete fuel pump/fuel filter module. ⁴⁵⁰ Lifetime filter. Does not require replacement under normal conditions.



BMW (cont'd)

	Oil	Air	Cabin*	Fuel
2019				
i8				
3 cyl. 1.5	VO-166			
M2				
6 cyl. 3.0 Turbo	VO-91			
M240i, M240i xDrive				
6 cyl. 3.0L Turbo	VO-169	VA-488		NS ⁴³⁷
M4				
6 cyl. 3.0L Turbo	VO-91			NS ⁴³⁷
M5				
V8 4.4L Turbo	VO-131			LF ⁴⁵⁰
M550i xDrive				
V8 4.4L Turbo	VO-131			NS ⁴³⁷
M6				
V8 4.4L Turbo	VO-131			LF ⁴⁵⁰
M760i xDrive				
V12 6.6L Turbo	VO-131			NS ⁴³⁷
M850i xDrive				
V8 4.4L Turbo	VO-131			NS ⁴³⁷
X1				
4 cyl. 2.0L Turbo	VO-166			NS ⁴³⁷
X2				
4 cyl. 2.0L Turbo	VO-166			NS ⁴³⁷
X3				
6 cyl. 3.0L Turbo	VO-169			NS ⁴³⁷
X4				
6 cyl. 3.0L Turbo	VO-169			NS ⁴³⁷
X5				
6 cyl. 3.0L Turbo	VO-169			NS ⁴³⁷
V8 4.4L Turbo	VO-131			NS ⁴³⁷
X6				
6 cyl. 3.0L Turbo	VO-91	VA-444		LF ⁴⁵⁰
V8 4.4L Turbo	VO-131			LF ⁴⁵⁰
X6M				
V8 4.4L Turbo	VO-131			LF ⁴⁵⁰
2018				
230i, 230i xDrive				
4 cyl. 2.0L Turbo		VA-488		
320i Series				
4 cyl. 2.0L Turbo	VO-91	VA-450		NS ⁴³⁷
330e				
4 cyl. 2.0 Hybrid		VA-488		LF ⁴⁵⁰
330i, 330i xDrive				
4 cyl. 2.0L Turbo		VA-488		LF ⁴⁵⁰
340i, 340i xDrive				
4 cyl. 3.0L Turbo	VO-169	VA-488		LF ⁴⁵⁰
430i, 430i xDrive				
4 cyl. 2.0L Turbo		VA-488		LF ⁴⁵⁰
440i, 440i xDrive				
6 cyl. 3.0L Turbo	VO-169	VA-488		LF ⁴⁵⁰
540d xDrive				
L6 3.0L	VO-169			

Se reporter à table de matière pour les notes en bas de page en français. Utilize el contenido para ver notas a pie.

NS - Non-Serviceable / Non réparable / No reparable LF - Life-Time Filter / Filtro para toda la vida / Filtre à vie

⁴³⁷ Requires replacement of the complete fuel pump/fuel filter module. ⁴⁵⁰ Lifetime filter. Does not require replacement under normal conditions.



BMW (cont'd)

2018

540i, 540i xDrive

6 cyl. 3.0 Turbo	VO-169			LF ⁴⁵⁰
------------------	--------	--	--	-------------------

640i, 640i xDrive

6 cyl. 3.0L Turbo	VO-91	VA-444		LF ⁴⁵⁰
-------------------	-------	--------	--	-------------------

650i, 650i xDrive

V8 4.4L Turbo	VO-131			LF ⁴⁵⁰
---------------	--------	--	--	-------------------

740e xDrive

4 cyl. 2.0 Turbo				LF ⁴⁵⁰
------------------	--	--	--	-------------------

740i, 740Li

6 cyl. 3.0L Turbo	VO-169			NS ⁴³⁷
-------------------	--------	--	--	-------------------

750i, 750i xDrive, 750Li, 750Li xDrive

V8 4.4L Turbo	VO-131			NS ⁴³⁷
---------------	--------	--	--	-------------------

Alpina B6 Gran Coupe

V8 4.4 Turbo	VO-131			NS ⁴³⁷
--------------	--------	--	--	-------------------

Alpina B7

V8 4.4L Turbo	VO-131			NS ⁴³⁷
---------------	--------	--	--	-------------------

M2

6 cyl 3.0 Turbo	VO-91	VA-490		
-----------------	-------	--------	--	--

M240i, M240i xDrive

6 cyl. 3.0L Turbo	VO-169	VA-488		NS ⁴³⁷
-------------------	--------	--------	--	-------------------

M3

6 cyl. 3.0L Turbo	VO-91			NS ⁴³⁷
-------------------	-------	--	--	-------------------

M4

6 cyl. 3.0L Turbo	VO-91			NS ⁴³⁷
-------------------	-------	--	--	-------------------

M5

V8 4.4L Turbo	VO-131			LF ⁴⁵⁰
---------------	--------	--	--	-------------------

M550i xDrive

V8 4.4L Turbo	VO-131			NS ⁴³⁷
---------------	--------	--	--	-------------------

M6

V8 4.4L Turbo	VO-131			LF ⁴⁵⁰
---------------	--------	--	--	-------------------

M760i xDrive

V12 6.6L Turbo	VO-131			NS ⁴³⁷
----------------	--------	--	--	-------------------

X1

4 cyl 2.0L Turbo	VO-166			NS ⁴³⁷
------------------	--------	--	--	-------------------

X2

4 cyl. 2.0L Turbo	VO-166			NS ⁴³⁷
-------------------	--------	--	--	-------------------

X3

6 cyl. 3.0L Turbo	VO-169			NS ⁴³⁷
-------------------	--------	--	--	-------------------

X4

4 cyl. 2.0L Turbo	VO-91	VA-423		NS ⁴³⁷
-------------------	-------	--------	--	-------------------

6 cyl. 3.0L Turbo	VO-91	VA-444		NS ⁴³⁷
-------------------	-------	--------	--	-------------------

X5

4 cyl. 2.0L Turbo (Hybrid)	VO-91			NS ⁴³⁷
----------------------------	-------	--	--	-------------------

6 cyl. 3.0L Gas Turbo	VO-91	VA-396		NS ⁴³⁷
-----------------------	-------	--------	--	-------------------

V8 4.4L Turbo	VO-131			NS ⁴³⁷
---------------	--------	--	--	-------------------

X5M

V8 4.4L Turbo	VO-131			NS ⁴³⁷
---------------	--------	--	--	-------------------

X6

6 cyl. 3.0L Turbo	VO-91	VA-444		LF ⁴⁵⁰
-------------------	-------	--------	--	-------------------

V8 4.4L Turbo	VO-131			LF ⁴⁵⁰
---------------	--------	--	--	-------------------

X6M

V8 4.4L Turbo	VO-131			LF ⁴⁵⁰
---------------	--------	--	--	-------------------

Se reporter à table de matière pour les notes en bas de page en français. Utilize el contenido para ver notas a pie.

NS - Non-Serviceable / Non réparable / No repairable LF - Life-Time Filter / Filtro para toda la vida / Filtre à vie

⁴³⁷ Requires replacement of the complete fuel pump/fuel filter module. ⁴⁵⁰ Lifetime filter. Does not require replacement under normal conditions.



BMW (cont'd)

	Oil	Air	Cabin*	Fuel
2017				
230i, 230i xDrive				
4 cyl. 2.0L Turbo		VA-488		
320i Series				
4 cyl. 2.0L Turbo	VO-91	VA-450		NS ⁴³⁷
330e				
4 cyl. 2.0 Hybrid		VA-488		LF ⁴⁵⁰
330i, 330i xDrive				
4 cyl. 2.0L Turbo		VA-488		LF ⁴⁵⁰
340i, 340i xDrive				
4 cyl. 3.0L Turbo	VO-169	VA-488		LF ⁴⁵⁰
430i, 430i xDrive				
4 cyl. 2.0L Turbo		VA-488		LF ⁴⁵⁰
440i, 440i xDrive				
6 cyl. 3.0L Turbo	VO-169	VA-488		LF ⁴⁵⁰
535i Series				
6 cyl. 3.0L Turbo	VO-91	VA-444		NS
540i, 540i xDrive				
6 cyl. 3.0 Turbo	VO-169			LF ⁴⁵⁰
550i Series				
V8 4.4L Turbo	VO-131			LF ⁴⁵⁰
640i, 640i xDrive				
6 cyl. 3.0L Turbo	VO-91	VA-444		LF ⁴⁵⁰
650i, 650i xDrive				
V8 4.4L Turbo	VO-131			LF ⁴⁵⁰
740e xDrive				
4 cyl. 2.0 Turbo				LF ⁴⁵⁰
740i, 740Li				
6 cyl. 3.0L Turbo	VO-169			NS ⁴³⁷
750i, 750i xDrive, 750Li, 750Li xDrive				
V8 4.4L Turbo	VO-131			NS ⁴³⁷
Alpina B6 Gran Coupe				
V8 4.4 Turbo	VO-131			NS ⁴³⁷
Alpina B7				
V8 4.4L Turbo	VO-131			NS ⁴³⁷
i8				
3 cyl. 1.5	VO-166			
M2				
6 cyl. 3.0 Turbo	VO-91	VA-490		
M240i, M240i xDrive				
6 cyl. 3.0L Turbo	VO-169	VA-488		NS ⁴³⁷
M3				
6 cyl. 3.0L Turbo	VO-91			NS ⁴³⁷
M4				
6 cyl. 3.0L Turbo	VO-91			NS ⁴³⁷
M6				
V8 4.4L Turbo	VO-131			LF ⁴⁵⁰
M760i xDrive				
V12 6.6L Turbo	VO-131			NS ⁴³⁷
X1				
4 cyl. 2.0L Turbo	VO-166			NS ⁴³⁷
X3				
4 cyl. 2.0L Turbo	VO-91	VA-423		NS ⁴³⁷

Se reporter à table de matière pour les notes en bas de page en français. Utilize el contenido para ver notas a pie.

NS - Non-Serviceable / Non réparable / No reparable LF - Life-Time Filter / Filtro para toda la vida / Filtre à vie

⁴³⁷ Requires replacement of the complete fuel pump/fuel filter module. ⁴⁵⁰ Lifetime filter. Does not require replacement under normal conditions.



BMW (cont'd)

2017

X3

6 cyl. 3.0L Turbo	VO-91	VA-444		NS ⁴³⁷
-------------------	-------	--------	--	-------------------

X4

4 cyl. 2.0L Turbo	VO-91	VA-423		NS ⁴³⁷
-------------------	-------	--------	--	-------------------

6 cyl. 3.0L Turbo	VO-91	VA-444		NS ⁴³⁷
-------------------	-------	--------	--	-------------------

X5

4 cyl. 2.0L Turbo (Hybrid)	VO-91			NS ⁴³⁷
----------------------------	-------	--	--	-------------------

6 cyl. 3.0L Gas Turbo	VO-91	VA-396		NS ⁴³⁷
-----------------------	-------	--------	--	-------------------

V8 4.4L Turbo	VO-131			NS ⁴³⁷
---------------	--------	--	--	-------------------

X5M

V8 4.4L Turbo	VO-131			NS ⁴³⁷
---------------	--------	--	--	-------------------

X6

6 cyl. 3.0L Turbo	VO-91	VA-444		LF ⁴⁵⁰
-------------------	-------	--------	--	-------------------

V8 4.4L Turbo	VO-131			LF ⁴⁵⁰
---------------	--------	--	--	-------------------

X6M

V8 4.4L Turbo	VO-131			LF ⁴⁵⁰
---------------	--------	--	--	-------------------

2016

228i, 228i xDrive

4 cyl. 2.0	VO-91	VA-450		LF
------------	-------	--------	--	----

320i Series

4 cyl. 2.0L Turbo	VO-91	VA-450		NS ⁴³⁷
-------------------	-------	--------	--	-------------------

328i, 328i xDrive

4 cyl. 2.0L Turbo	VO-91	VA-450		NS ⁴³⁷
-------------------	-------	--------	--	-------------------

330e

4 cyl. 2.0 Hybrid		VA-488		LF ⁴⁵⁰
-------------------	--	--------	--	-------------------

335i, 335i xDrive

6 cyl. 3.0L Turbo	VO-91	VA-490		LF ⁴⁵⁰
-------------------	-------	--------	--	-------------------

340i, 340i xDrive

4 cyl. 3.0L Turbo	VO-169	VA-488		LF ⁴⁵⁰
-------------------	--------	--------	--	-------------------

428i, 428i xDrive

4 cyl. 2.0 Turbo	VO-91	VA-450		LF ⁴⁵⁰
------------------	-------	--------	--	-------------------

435i, 435i xDrive

6 cyl. 3.0 Turbo	VO-91	VA-490		LF ⁴⁵⁰
------------------	-------	--------	--	-------------------

528i, 528i xDrive

4 cyl. 2.0L Turbo	VO-91	VA-443		NS ⁴³⁷
-------------------	-------	--------	--	-------------------

535i Series

6 cyl. 3.0L Turbo	VO-91	VA-444		NS
-------------------	-------	--------	--	----

550i Series

V8 4.4L Turbo	VO-131			LF ⁴⁵⁰
---------------	--------	--	--	-------------------

640i, 640i xDrive

6 cyl. 3.0L DI Turbo	VO-91	VA-444		LF ⁴⁵⁰
----------------------	-------	--------	--	-------------------

650i, 650i xDrive

V8 4.4L DI Turbo	VO-131			LF ⁴⁵⁰
------------------	--------	--	--	-------------------

740i, 740Li

6 cyl. 3.0L Turbo	VO-169			NS ⁴³⁷
-------------------	--------	--	--	-------------------

750i, 750i xDrive, 750Li, 750Li xDrive

V8 4.4L Turbo	VO-131			LF
---------------	--------	--	--	----

ActiveHybrid 5

6 cyl. 3.0L Turbo	VO-91	VA-444		LF ⁴⁵⁰
-------------------	-------	--------	--	-------------------

Alpina B6 Gran Coupe

V8 4.4 Turbo	VO-131			NS ⁴³⁷
--------------	--------	--	--	-------------------

Se reporter à table de matière pour les notes en bas de page en français. Utilize el contenido para ver notas a pie.

NS - Non-Serviceable / Non réparable / No reparable LF - Life-Time Filter / Filtro para toda la vida / Filtre à vie

⁴³⁷ Requires replacement of the complete fuel pump/fuel filter module. ⁴⁵⁰ Lifetime filter. Does not require replacement under normal conditions.



BMW (cont'd)

	Oil	Air	Cabin*	Fuel
2016				
i8				
3 cyl. 1.5	VO-166			
M2				
6 cyl. 3.0 Turbo	VO-91	VA-490		
M235i, M235i xDrive				
6 cyl. 3.0 FI Turbo	VO-91	VA-490		
M3				
6 cyl. 3.0L Turbo	VO-91			NS ⁴³⁷
M4				
6 cyl. 3.0L Turbo	VO-91			NS ⁴³⁷
M5				
V8 4.4L Turbo	VO-131			LF ⁴⁵⁰
M6				
V8 4.4L Turbo	VO-131			LF ⁴⁵⁰
X1				
4 cyl. 2.0L Turbo	VO-166			NS ⁴³⁷
X3				
4 cyl. 2.0L Gas Turbo	VO-91	VA-423		NS ⁴³⁷
6 cyl. 3.0L Turbo	VO-91	VA-444		NS ⁴³⁷
X4				
4 cyl. 2.0L Turbo	VO-91	VA-423		NS ⁴³⁷
6 cyl. 3.0L Turbo	VO-91	VA-444		NS ⁴³⁷
X5				
4 cyl. 2.0L Turbo (Hybrid)	VO-91			NS ⁴³⁷
6 cyl. 3.0L Turbo	VO-91	VA-396		NS ⁴³⁷
V8 4.4L Turbo	VO-131			NS ⁴³⁷
X5M				
V8 4.4L Turbo	VO-131			NS
X6				
6 cyl. 3.0L Turbo	VO-91	VA-444		LF ⁴⁵⁰
V8 4.4L Turbo	VO-131			LF ⁴⁵⁰
X6M				
V8 4.4L Turbo	VO-131			LF ⁴⁵⁰
Z4				
4 cyl. 2.0L Turbo	VO-91	VA-443		NS ⁴³⁷
6 cyl. 3.0L Turbo	VO-91	VA-317		NS ⁴³⁷
2015				
228i, 228i xDrive				
4 cyl. 2.0	VO-91	VA-450		LF
320i Series				
4 cyl. 2.0L Turbo	VO-91	VA-450		NS ⁴³⁷
328i, 328i xDrive				
4 cyl. 2.0L Turbo	VO-91	VA-450		NS ⁴³⁷
335i, 335i xDrive				
6 cyl. 3.0L Turbo	VO-91	VA-490		LF ⁴⁵⁰
428i, 428i xDrive				
4 cyl. 2.0 Turbo	VO-91	VA-450		LF ⁴⁵⁰
435i, 435i xDrive				
6 cyl. 3.0 Turbo	VO-91	VA-490		LF ⁴⁵⁰
528i, 528i xDrive				
4 cyl. 2.0L Turbo	VO-91	VA-443		NS ⁴³⁷

Se reporter à table de matière pour les notes en bas de page en français. Utilize el contenido para ver notas a pie.

NS - Non-Serviceable / Non réparable / No repairable LF - Life-Time Filter / Filtro para toda la vida / Filtre à vie

⁴³⁷ Requires replacement of the complete fuel pump/fuel filter module. ⁴⁵⁰ Lifetime filter. Does not require replacement under normal conditions.



BMW (cont'd)

2015

535i Series

6 cyl. 3.0L Turbo	VO-91	VA-444		NS
-------------------	-------	--------	--	----

550i Series

V8 4.4L Turbo	VO-131			LF ⁴⁵⁰
---------------	--------	--	--	-------------------

640i, 640i xDrive

6 cyl. 3.0L DI Turbo	VO-91	VA-444		LF ⁴⁵⁰
----------------------	-------	--------	--	-------------------

650i, 650i xDrive

V8 4.4L DI Turbo	VO-131			LF ⁴⁵⁰
------------------	--------	--	--	-------------------

740i, 740Li

6 cyl. 3.0L Turbo	VO-91	VA-444		NS
-------------------	-------	--------	--	----

750i, 750i xDrive, 750Li, 750Li xDrive

V8 4.4L Turbo	VO-131			NS ⁴³⁷
---------------	--------	--	--	-------------------

760Li

V12 6.0L Turbo	VO-131			LF ⁴⁵⁰
----------------	--------	--	--	-------------------

ActiveHybrid 3

6 cyl. 3.0L Turbo	VO-91	VA-490		LF ⁴⁵⁰
-------------------	-------	--------	--	-------------------

ActiveHybrid 5

6 cyl. 3.0L Turbo	VO-91	VA-444		LF ⁴⁵⁰
-------------------	-------	--------	--	-------------------

ActiveHybrid 7

6 cyl. 3.0L Turbo	VO-91	VA-444		LF ⁴⁵⁰
-------------------	-------	--------	--	-------------------

Alpina B6 Gran Coupe

V8 4.4 Turbo	VO-131			NS ⁴³⁷
--------------	--------	--	--	-------------------

Alpina B7

V8 4.4L Turbo	VO-131			NS ⁴³⁷
---------------	--------	--	--	-------------------

i8

3 cyl. 1.5	VO-166			
------------	--------	--	--	--

M235i, M235i xDrive

6 cyl. 3.0 FI Turbo	VO-91	VA-490		
---------------------	-------	--------	--	--

M3

6 cyl. 3.0L Turbo	VO-91			NS ⁴³⁷
-------------------	-------	--	--	-------------------

M4

6 cyl. 3.0L Turbo	VO-91			NS ⁴³⁷
-------------------	-------	--	--	-------------------

M5

V8 4.4L Turbo	VO-131			LF ⁴⁵⁰
---------------	--------	--	--	-------------------

M6

V8 4.4L Turbo	VO-131			LF ⁴⁵⁰
---------------	--------	--	--	-------------------

X1

4 cyl. 2.0L Turbo	VO-91	VA-443	VCA-1103	NS ⁴³⁷
-------------------	-------	--------	----------	-------------------

6 cyl. 3.0L Turbo	VO-91	VA-396	VCA-1103	NS ⁴³⁷
-------------------	-------	--------	----------	-------------------

X3

4 cyl. 2.0L Turbo	VO-91	VA-423		NS ⁴³⁷
-------------------	-------	--------	--	-------------------

6 cyl. 3.0L Turbo	VO-91	VA-444		NS ⁴³⁷
-------------------	-------	--------	--	-------------------

X4

4 cyl. 2.0L Turbo	VO-91	VA-423		NS ⁴³⁷
-------------------	-------	--------	--	-------------------

6 cyl. 3.0L Turbo	VO-91	VA-444		NS ⁴³⁷
-------------------	-------	--------	--	-------------------

X5

6 cyl. 3.0L Gas Turbo	VO-91	VA-396		NS ⁴³⁷
-----------------------	-------	--------	--	-------------------

V8 4.4L Turbo	VO-131			NS ⁴³⁷
---------------	--------	--	--	-------------------

X5M

V8 4.4L Turbo	VO-131			NS ⁴³⁷
---------------	--------	--	--	-------------------

X6

6 cyl. 3.0L Turbo	VO-91	VA-444		LF ⁴⁵⁰
-------------------	-------	--------	--	-------------------

Se reporter à table de matière pour les notes en bas de page en français. Utilize el contenido para ver notas a pie.

NS - Non-Serviceable / Non réparable / No reparable LF - Life-Time Filter / Filtro para toda la vida / Filtre à vie

⁴³⁷ Requires replacement of the complete fuel pump/fuel filter module. ⁴⁵⁰ Lifetime filter. Does not require replacement under normal conditions.



BMW (cont'd)

	Oil	Air	Cabin*	Fuel
2015				
X6				
V8 4.4L Turbo	VO-131			LF ⁴⁵⁰
X6M				
V8 4.4L Turbo	VO-131			LF ⁴⁵⁰
Z4				
4 cyl. 2.0L Turbo	VO-91	VA-443		NS ⁴³⁷
6 cyl. 3.0L Turbo	VO-91	VA-317		NS ⁴³⁷
2014				
228i				
4 cyl. 2.0	VO-91	VA-450		
320i Series				
4 cyl. 2.0L Turbo	VO-91	VA-450		NS ⁴³⁷
328i, 328i xDrive				
4 cyl. 2.0L Turbo	VO-91	VA-450		NS ⁴³⁷
335i, 335i xDrive				
6 cyl. 3.0L Turbo	VO-91	VA-490		LF ⁴⁵⁰
428i, 428i xDrive				
4 cyl. 2.0 Turbo	VO-91	VA-450		LF ⁴⁵⁰
435i, 435i xDrive				
6 cyl. 3.0 Turbo	VO-91	VA-490		LF ⁴⁵⁰
528i, 528i xDrive				
4 cyl. 2.0L Turbo	VO-91	VA-443		NS ⁴³⁷
535i Series				
6 cyl. 3.0L Turbo	VO-91	VA-444		NS ⁴³⁷
550i Series				
V8 4.4L Turbo	VO-131			LF ⁴⁵⁰
640i, 640i xDrive				
6 cyl. 3.0L DI Turbo	VO-91	VA-444		LF ⁴⁵⁰
650i, 650i xDrive				
V8 4.4L DI Turbo	VO-131			NS ⁴³⁷
740i, 740Li				
6 cyl. 3.0L Turbo	VO-91	VA-444		NS ⁴³⁷
750i, 750i xDrive, 750Li, 750Li xDrive				
V8 4.4L Turbo	VO-131			NS ⁴³⁷
760Li				
V12 6.0L Turbo	VO-131			LF ⁴⁵⁰
ActiveHybrid 3				
6 cyl. 3.0L Turbo	VO-91	VA-490		LF ⁴⁵⁰
ActiveHybrid 5				
6 cyl. 3.0L Turbo	VO-91	VA-444		LF ⁴⁵⁰
ActiveHybrid 7				
6 cyl. 3.0L Turbo	VO-91	VA-444		LF ⁴⁵⁰
Alpina B7				
V8 4.4L Turbo	VO-131			NS ⁴³⁷
i8				
3 cyl. 1.5	VO-166			
M235i, M235i xDrive				
6 cyl. 3.0 FI Turbo	VO-91	VA-490		
M5				
V8 4.4L Turbo	VO-131			LF ⁴⁵⁰
M6				
V8 4.4L Turbo	VO-131			LF ⁴⁵⁰

Se reporter à table de matière pour les notes en bas de page en français. Utilize el contenido para ver notas a pie.

NS - Non-Serviceable / Non réparable / No reparable LF - Life-Time Filter / Filtro para toda la vida / Filtre à vie

⁴³⁷ Requires replacement of the complete fuel pump/fuel filter module. ⁴⁵⁰ Lifetime filter. Does not require replacement under normal conditions.



BMW (cont'd)

2014

X1

4 cyl. 2.0L Turbo	VO-91	VA-443	VCA-1103	NS ⁴³⁷
6 cyl. 3.0L Turbo	VO-91	VA-396	VCA-1103	NS ⁴³⁷

X3

4 cyl. 2.0L Turbo	VO-91	VA-423		NS ⁴³⁷
6 cyl. 3.0L Turbo	VO-91	VA-444		NS ⁴³⁷

X5

6 cyl. 3.0L Gas Turbo	VO-91	VA-396		NS ⁴³⁷
V8 4.4L Turbo	VO-131			NS ⁴³⁷

X6

6 cyl. 3.0L Turbo	VO-91	VA-444		LF ⁴⁵⁰
V8 4.4L Turbo	VO-131			LF ⁴⁵⁰

X6M

V8 4.4L Turbo	VO-131			LF ⁴⁵⁰
---------------	--------	--	--	-------------------

Z4

4 cyl. 2.0L Turbo	VO-91 ¹¹²⁵	VA-443		NS ⁴³⁷
6 cyl. 3.0L Turbo	VO-91	VA-317		NS ⁴³⁷

2013

128i

6 cyl. 3.0L	VO-91	VA-323	VCA-1103	NS ⁴³⁷
-------------	-------	--------	----------	-------------------

135i

6 cyl. 3.0L Turbo	VO-91	VA-396	VCA-1103	NS ⁴³⁷
-------------------	-------	--------	----------	-------------------

320i Series

4 cyl. 2.0L Turbo	VO-91	VA-450		NS ⁴³⁷
-------------------	-------	--------	--	-------------------

328i, 328i xDrive

4 cyl. 2.0L Turbo	VO-91 ¹¹²⁵	VA-450		NS ⁴³⁷
6 cyl. 3.0L	VO-91	VA-323		LF ⁴⁵⁰

335i, 335i xDrive

6 cyl. 3.0L Turbo	VO-91	VA-396 ⁶⁴³		LF ⁴⁵⁰
-------------------	-------	-----------------------	--	-------------------

528i, 528i xDrive

4 cyl. 2.0L Turbo	VO-91 ¹¹²⁵	VA-443		NS ⁴³⁷
-------------------	-----------------------	--------	--	-------------------

535i Series

6 cyl. 3.0L Turbo	VO-91	VA-444		NS ⁴³⁷
-------------------	-------	--------	--	-------------------

550i Series

V8 4.4L Turbo	VO-131			LF ⁴⁵⁰
---------------	--------	--	--	-------------------

640i, 640i xDrive

6 cyl. 3.0L DI Turbo	VO-91	VA-444		LF ⁴⁵⁰
----------------------	-------	--------	--	-------------------

650i, 650i xDrive

V8 4.4L DI Turbo	VO-131			NS ⁴³⁷
------------------	--------	--	--	-------------------

740i, 740Li

6 cyl. 3.0L Turbo	VO-91	VA-444		NS ⁴³⁷
-------------------	-------	--------	--	-------------------

750i, 750i xDrive, 750Li, 750Li xDrive

V8 4.4L Turbo	VO-131			NS ⁴³⁷
---------------	--------	--	--	-------------------

760Li

V12 6.0L Turbo	VO-131			LF ⁴⁵⁰
----------------	--------	--	--	-------------------

ActiveHybrid 3

6 cyl. 3.0L Turbo	VO-91	VA-490		LF ⁴⁵⁰
-------------------	-------	--------	--	-------------------

ActiveHybrid 5

6 cyl. 3.0L Turbo	VO-91	VA-444		LF ⁴⁵⁰
-------------------	-------	--------	--	-------------------

ActiveHybrid 7

6 cyl. 3.0L Turbo	VO-91	VA-444		LF ⁴⁵⁰
-------------------	-------	--------	--	-------------------

Se reporter à table de matière pour les notes en bas de page en français. Utilize el contenido para ver notas a pie.

NS - Non-Serviceable / Non réparable / No reparable LF - Life-Time Filter / Filtro para toda la vida / Filtre à vie

⁴³⁷ Requires replacement of the complete fuel pump/fuel filter module. ⁴⁵⁰ Lifetime filter. Does not require replacement under normal conditions. ⁶⁴³ Coupe or Convertible; Sedan VA-490 ¹¹²⁵with Aluminum filter housing.



BMW (cont'd)

	Oil	Air	Cabin*	Fuel
2013				
Alpina B7				
V8 4.4L Turbo	VO-131			NS ⁴³⁷
M5				
V8 4.4L Turbo	VO-131			LF ⁴⁵⁰
M6				
V8 4.4L Turbo	VO-131			LF ⁴⁵⁰
X1				
4 cyl. 2.0L Turbo	VO-91 ¹¹²⁵	VA-443	VCA-1103	NS ⁴³⁷
6 cyl. 3.0L	VO-91	VA-396	VCA-1103	NS ⁴³⁷
X3				
4 cyl. 2.0L Turbo	VO-91	VA-423		NS ⁴³⁷
6 cyl. 3.0L Turbo	VO-91	VA-444		NS ⁴³⁷
X5				
6 cyl. 3.0L Diesel Turbo	VO-140			
6 cyl. 3.0L Turbo	VO-91	VA-444		NS ⁴³⁷
V8 4.4L Turbo	VO-131			NS ⁴³⁷
X5M				
V8 4.4L Turbo	VO-131			NS ⁴³⁷
X6				
6 cyl. 3.0L Turbo	VO-91	VA-444		LF ⁴⁵⁰
V8 4.4L Turbo	VO-131			LF ⁴⁵⁰
X6M				
V8 4.4L Turbo	VO-131			LF ⁴⁵⁰
Z4				
4 cyl. 2.0L Turbo	VO-91 ¹¹²⁵	VA-443		NS ⁴³⁷
6 cyl. 3.0L Turbo	VO-91	VA-317		NS ⁴³⁷
2012				
128i				
6 cyl. 3.0L	VO-91	VA-323	VCA-1103	NS ⁴³⁷
135i				
6 cyl. 3.0L Turbo	VO-91	VA-396	VCA-1103	NS ⁴³⁷
320i Series				
4 cyl. 2.0L FI Turbo (Canada)	VO-91	VA-450		NS ⁴³⁷
328i, 328i xDrive				
4 cyl. 2.0L Turbo	VO-91 ¹¹²⁵	VA-450		NS
6 cyl. 3.0L	VO-91	VA-323	VCA-1103	LF ⁴³⁷
335i, 335i xDrive				
6 cyl. 3.0L Turbo	VO-91	VA-396	VCA-1103	LF ⁴⁵⁰
528i, 528i xDrive				
4 cyl. 2.0L Turbo	VO-91 ¹¹²⁵	VA-443		NS ⁴³⁷
535i Series				
6 cyl. 3.0L Turbo	VO-91	VA-444		NS ⁴³⁷
550i Series				
V8 4.4L Turbo	VO-131			LF ⁴⁵⁰
640i, 640i xDrive				
6 cyl. 3.0L DI Turbo	VO-91	VA-444		LF ⁴⁵⁰
650i, 650i xDrive				
V8 4.4L DI Turbo	VO-131			NS ⁴³⁷
740i, 740Li				
6 cyl. 3.0L Turbo	VO-91	VA-444		NS ⁴³⁷
750i, 750i xDrive, 750Li, 750Li xDrive				
V8 4.4L Hybrid	VO-131			NS ⁴³⁷

Se reporter à table de matière pour les notes en bas de page en français. Utilize el contenido para ver notas a pie.

NS - Non-Serviceable / Non réparable / No reparable LF - Life-Time Filter / Filtro para toda la vida / Filtre à vie

⁴³⁷ Requires replacement of the complete fuel pump/fuel filter module. ⁴⁵⁰ Lifetime filter. Does not require replacement under normal conditions. ¹¹²⁵with Aluminum filter housing.



BMW (cont'd)

2012

750i, 750i xDrive, 750Li, 750Li xDrive

V8 4.4L Turbo	VO-131			NS ⁴³⁷
760Li				
V12 6.0L Turbo	VO-131			LF ⁴⁵⁰
ActiveHybrid 5				
6 cyl. 3.0L Turbo	VO-91	VA-444		LF ⁴⁵⁰
Alpina B7				
V8 4.4L Turbo	VO-131			NS ⁴³⁷
M5				
V8 4.4L Turbo	VO-131			LF ⁴⁵⁰
M6				
V8 4.4L Turbo	VO-131			LF ⁴⁵⁰
X1				
4 cyl 2.0L Turbo (Canada)	VO-91 ¹¹²⁵	VA-443	VCA-1103	NS ⁴³⁷
X3				
6 cyl. 3.0L Non turbo	VO-91	VA-423		NS ⁴³⁷
6 cyl. 3.0L Turbo	VO-91	VA-444		NS ⁴³⁷
X5				
6 cyl 3.0L Diesel Turbo	VO-140			
6 cyl. 3.0L Turbo	VO-91	VA-444		NS ⁴³⁷
V8 4.4L Turbo	VO-131			NS ⁴³⁷
X5M				
V8 4.4L Turbo	VO-131			NS ⁴³⁷
X6				
6 cyl. 3.0L Turbo	VO-91	VA-444		LF ⁴⁵⁰
V8 4.4L Turbo	VO-131			LF ⁴⁵⁰
X6M				
V8 4.4L Turbo	VO-131			LF ⁴⁵⁰
Z4				
4 cyl. 2.0L Turbo	VO-91 ¹¹²⁵	VA-443		NS ⁴³⁷
6 cyl. 3.0L Turbo	VO-91	VA-317		NS ⁴³⁷
2011				
1M				
L6 3.0L Turbo	VO-91	VA-317	VCA-1103	NS ⁴³⁷
128i				
6 cyl. 3.0L	VO-91	VA-323	VCA-1103	NS ⁴³⁷
135i				
6 cyl 3.0L Turbo	VO-91	VA-396	VCA-1103	NS ⁴³⁷
323i				
6 cyl. 2.5L FI (Canada)	VO-91	VA-323	VCA-1103	LF ⁴⁵⁰
328i, 328i xDrive				
6 cyl. 3.0L	VO-91	VA-323	VCA-1103	LF ⁴⁵⁰
335d				
6 cyl. 3.0L Diesel Turbo	VO-140		VCA-1103	
335i, 335i xDrive				
6 cyl. 3.0L Turbo	VO-91	VA-396	VCA-1103	LF ⁴⁵⁰
528i, 528i xDrive				
6 cyl. 3.0L	VO-91	VA-337		NS ⁴³⁷
535i Series				
6 cyl 3.0L Turbo	VO-91	VA-444		NS ⁴³⁷
550i Series				
V8 4.4L Turbo	VO-131			LF ⁴⁵⁰

Se reporter à table de matière pour les notes en bas de page en français. Utilize el contenido para ver notas a pie.

NS - Non-Serviceable / Non réparable / No reparable LF - Life-Time Filter / Filtro para toda la vida / Filtre à vie

⁴³⁷ Requires replacement of the complete fuel pump/fuel filter module. ⁴⁵⁰ Lifetime filter. Does not require replacement under normal conditions. ¹¹²⁵with Aluminum filter housing.



BMW (cont'd)

	Oil	Air	Cabin*	Fuel
2011				
740i, 740Li				
6 cyl. 3.0L Turbo	VO-91	VA-444		NS ⁴³⁷
750i, 750i xDrive, 750Li, 750Li xDrive				
V8 4.4L Hybrid	VO-131			NS ⁴³⁷
V8 4.4L Turbo	VO-131			NS ⁴³⁷
760Li				
V12 6.0L Turbo	VO-131			LF ⁴⁵⁰
Alpina B7				
V8 4.4L Turbo	VO-131			NS ⁴³⁷
X3				
6 cyl. 3.0L Non turbo	VO-91	VA-423		NS ⁴³⁷
6 cyl. 3.0L Turbo	VO-91	VA-444		NS ⁴³⁷
X5				
6 cyl. 3.0L Diesel Turbo	VO-140			
6 cyl. 3.0L Turbo	VO-91	VA-444		NS ⁴³⁷
V8 4.4L Turbo	VO-131			NS ⁴³⁷
X5M				
V8 4.4L Turbo	VO-131			NS ⁴³⁷
X6				
6 cyl. 3.0L Turbo	VO-91	VA-444		LF ⁴⁵⁰
V8 4.4L Turbo	VO-131			LF ⁴⁵⁰
V8 4.4L Turbo (Hybrid)	VO-131			LF ⁴⁵⁰
X6M				
V8 4.4L Turbo	VO-131			LF ⁴⁵⁰
Z4				
6 cyl. 3.0L Non turbo	VO-91	VA-443		NS ⁴³⁷
6 cyl. 3.0L Turbo	VO-91	VA-317		NS ⁴³⁷
2010				
128i				
6 cyl. 3.0L	VO-91	VA-323	VCA-1103	NS ⁴³⁷
135i				
6 cyl. 3.0L Turbo	VO-91	VA-317	VCA-1103	NS ⁴³⁷
323i				
6 cyl. 2.5L FI (Canada)	VO-91	VA-323	VCA-1103	LF ⁴⁵⁰
328i, 328i xDrive				
6 cyl. 3.0L	VO-91	VA-323	VCA-1103	LF ⁴⁵⁰
335d				
6 cyl. 3.0L Diesel Turbo	VO-140		VCA-1103	
335i, 335i xDrive				
6 cyl. 3.0L Turbo	VO-91	VA-317	VCA-1103	LF ⁴⁵⁰
528i, 528i xDrive				
6 cyl. 3.0L	VO-91	VA-337		NS ⁴³⁷
535i Series				
6 cyl. 3.0L Turbo	VO-91	VA-317		NS ⁴³⁷
550i Series				
V8 4.4L Turbo	VO-131			LF ⁴⁵⁰
V8 4.8L	VO-112	VA-364		NS ⁴³⁷
650i, 650i xDrive				
V8 4.8L	VO-112	VA-364		NS ⁴³⁷
750i, 750i xDrive, 750Li, 750Li xDrive				
V8 4.4L Turbo	VO-131			NS ⁴³⁷

Se reporter à table de matière pour les notes en bas de page en français. Utilize el contenido para ver notas a pie.

NS - Non-Serviceable / Non réparable / No repairable LF - Life-Time Filter / Filtro para toda la vida / Filtre à vie

⁴³⁷ Requires replacement of the complete fuel pump/fuel filter module. ⁴⁵⁰ Lifetime filter. Does not require replacement under normal conditions.



BMW (cont'd)

2010

760Li

V12 6.0L Turbo	VO-131			LF ⁴⁵⁰
----------------	--------	--	--	-------------------

M5

V10 5.0L				LF ⁴⁵⁰
----------	--	--	--	-------------------

M6

V10 5.0L				LF ⁴⁵⁰
----------	--	--	--	-------------------

X3

6 cyl. 3.0L	VO-91	VA-367	VCA-1162	NS ⁴³⁷
-------------	-------	--------	----------	-------------------

X5

6 cyl 3.0L Diesel Turbo	VO-140			
6 cyl. 3.0L	VO-91	VA-373		LF ⁴⁵⁰
V8 4.8L	VO-112			LF ⁴⁵⁰

X5M

V8 4.4L Turbo	VO-131			NS ⁴³⁷
---------------	--------	--	--	-------------------

X6

6 cyl. 3.0L Turbo	VO-91	VA-444		LF ⁴⁵⁰
V8 4.4L Turbo	VO-131			LF ⁴⁵⁰
V8 4.4L Turbo (Hybrid)	VO-131			LF ⁴⁵⁰

X6M

V8 4.4L Turbo	VO-131			LF ⁴⁵⁰
---------------	--------	--	--	-------------------

Z4

6 cyl. 3.0L Non turbo	VO-91	VA-443		NS ⁴³⁷
6 cyl. 3.0L Turbo	VO-91	VA-317		NS ⁴³⁷

2009

128i

6 cyl. 3.0L	VO-91	VA-323	VCA-1103	NS ⁴³⁷
-------------	-------	--------	----------	-------------------

135i

6 cyl 3.0L Turbo	VO-91	VA-317	VCA-1103	NS ⁴³⁷
------------------	-------	--------	----------	-------------------

323i

6 cyl. 2.5L FI (Canada)	VO-91	VA-323	VCA-1103	LF ⁴⁵⁰
-------------------------	-------	--------	----------	-------------------

328i, 328i xDrive

6 cyl. 3.0L	VO-91	VA-323	VCA-1103	LF ⁴⁵⁰
-------------	-------	--------	----------	-------------------

335d

6 cyl. 3.0L Diesel Turbo	VO-140		VCA-1103	
--------------------------	--------	--	----------	--

335i, 335i xDrive

6 cyl. 3.0L Turbo	VO-91	VA-317	VCA-1103	LF ⁴⁵⁰
-------------------	-------	--------	----------	-------------------

528i, 528i xDrive

6 cyl. 3.0L	VO-91	VA-337		NS ⁴³⁷
-------------	-------	--------	--	-------------------

535i Series

6 cyl 3.0L Turbo	VO-91	VA-317		NS ⁴³⁷
------------------	-------	--------	--	-------------------

550i Series

V8 4.8L FI	VO-112	VA-364		NS ⁴³⁷
------------	--------	--------	--	-------------------

650i, 650i xDrive

V8 4.8L FI	VO-112	VA-364		NS ⁴³⁷
------------	--------	--------	--	-------------------

750i, 750i xDrive, 750Li, 750Li xDrive

V8 4.4L Turbo	VO-131			
---------------	--------	--	--	--

M5

V10 5.0L FI				LF ⁴⁵⁰
-------------	--	--	--	-------------------

M6

V10 5.0L FI				LF ⁴⁵⁰
-------------	--	--	--	-------------------

X3

6 cyl. 3.0L FI	VO-91	VA-367	VCA-1162	NS ⁴³⁷
----------------	-------	--------	----------	-------------------

Se reporter à table de matière pour les notes en bas de page en français. Utilize el contenido para ver notas a pie.

NS - Non-Serviceable / Non réparable / No reparable LF - Life-Time Filter / Filtro para toda la vida / Filtre à vie

⁴³⁷ Requires replacement of the complete fuel pump/fuel filter module. ⁴⁵⁰ Lifetime filter. Does not require replacement under normal conditions.



BMW (cont'd)

	Oil	Air	Cabin*	Fuel
2009				
X5				
6 cyl 3.0L Diesel Turbo	VO-140			
6 cyl. 3.0L FI	VO-91	VA-373		LF ⁴⁵⁰
V8 4.8L FI	VO-112			LF ⁴⁵⁰
X6				
6 cyl. 3.0L Turbo	VO-91	VA-444		LF ⁴⁵⁰
V8 4.4L Turbo	VO-131			LF ⁴⁵⁰
Z4				
6 cyl. 3.0L Non turbo	VO-91	VA-443		NS ⁴³⁷
6 cyl. 3.0L Turbo	VO-91	VA-317		NS ⁴³⁷
2008				
128i				
6 cyl. 3.0L	VO-91	VA-323	VCA-1103	NS ⁴³⁷
135i				
6 cyl 3.0L Turbo	VO-91	VA-317	VCA-1103	NS ⁴³⁷
323i				
6 cyl. 2.5L FI (Canada)	VO-91	VA-323	VCA-1103	LF ⁴⁵⁰
328i, 328xi				
6 cyl. 3.0L FI	VO-91	VA-323	VCA-1103	NS ⁴³⁷
335i, 335xi				
6 cyl. 3.0L DI Turbo	VO-91	VA-317	VCA-1103	NS ⁴³⁷
528i, 528i xDrive				
6 cyl. 3.0L	VO-91	VA-337		NS ⁴³⁷
535i Series				
6 cyl 3.0L Turbo	VO-91	VA-317		NS ⁴³⁷
550i Series				
V8 4.8L FI	VO-112	VA-364		NS ⁴³⁷
650i, 650i xDrive				
V8 4.8L FI	VO-112	VA-364		NS ⁴³⁷
750i, 750i xDrive, 750Li, 750Li xDrive				
V8 4.8L	VO-112			
760Li				
V12 6.0L FI	VO-112			
Alpina B7				
V8 4.4L Supercharged	VO-128			
M5				
V10 5.0L FI				LF ⁴⁵⁰
M6				
V10 5.0L FI				LF ⁴⁵⁰
X3				
6 cyl. 3.0L FI	VO-91	VA-367	VCA-1162	NS ⁴³⁷
X5				
6 cyl. 3.0L FI	VO-91	VA-373		LF ⁴⁵⁰
V8 4.8L FI	VO-112			LF ⁴⁵⁰
X6				
6 cyl. 3.0L Turbo	VO-91	VA-444		LF ⁴⁵⁰
V8 4.4L Turbo	VO-131			LF ⁴⁵⁰
Z4				
6 cyl. 3.0L FI	VO-91	VA-367		NS ⁴³⁷
6 cyl. 3.2L FI	VO-130	VA-337		NS ⁴³⁷

Se reporter à table de matière pour les notes en bas de page en français. Utilize el contenido para ver notas a pie.

NS - Non-Serviceable / Non réparable / No repairable LF - Life-Time Filter / Filtro para toda la vida / Filtre à vie

⁴³⁷ Requires replacement of the complete fuel pump/fuel filter module. ⁴⁵⁰ Lifetime filter. Does not require replacement under normal conditions.



BMW (cont'd)

2007

323i

6 cyl. 2.5L FI (Canada)	VO-91	VA-323	VCA-1103	LF ⁴⁵⁰
-------------------------	-------	--------	----------	-------------------

328i, 328xi

6 cyl. 3.0L FI	VO-91	VA-323	VCA-1103	NS ⁴³⁷
----------------	-------	--------	----------	-------------------

335i, 335xi

6 cyl. 3.0L DI Turbo	VO-91	VA-317	VCA-1103	NS ⁴³⁷
----------------------	-------	--------	----------	-------------------

525i, 525xi

6 cyl. 3.0L FI	VO-91	VA-337		NS ⁴³⁷
----------------	-------	--------	--	-------------------

530i, 530iT, 530xi

6 cyl. 3.0L FI	VO-91	VA-337		NS ⁴³⁷
----------------	-------	--------	--	-------------------

550i Series

V8 4.8L FI	VO-112	VA-364		NS ⁴³⁷
------------	--------	--------	--	-------------------

650i, 650i xDrive

V8 4.8L FI	VO-112	VA-364		NS ⁴³⁷
------------	--------	--------	--	-------------------

750i, 750i xDrive, 750Li, 750Li xDrive

V8 4.8L	VO-112			
---------	--------	--	--	--

760Li

V12 6.0L FI	VO-112			
-------------	--------	--	--	--

Alpina B7

V8 4.4L Supercharged	VO-128			
----------------------	--------	--	--	--

M5

V10 5.0L FI				LF ⁴⁵⁰
-------------	--	--	--	-------------------

M6

V10 5.0L FI				LF ⁴⁵⁰
-------------	--	--	--	-------------------

X3

6 cyl. 3.0L FI	VO-91	VA-367	VCA-1162	NS ⁴³⁷
----------------	-------	--------	----------	-------------------

X5

6 cyl. 3.0L FI	VO-91	VA-373		LF ⁴⁵⁰
----------------	-------	--------	--	-------------------

V8 4.8L FI	VO-112			LF ⁴⁵⁰
------------	--------	--	--	-------------------

Z4

6 cyl. 3.0L FI	VO-91	VA-367		NS ⁴³⁷
----------------	-------	--------	--	-------------------

6 cyl. 3.2L FI	VO-130	VA-337		NS ⁴³⁷
----------------	--------	--------	--	-------------------

2006

323i

6 cyl. 2.5L FI (Canada)	VO-91	VA-323	VCA-1103	LF ⁴⁵⁰
-------------------------	-------	--------	----------	-------------------

325i, 325xi

6 cyl. 3.0L FI (Sedan)	VO-91	VA-323	VCA-1103	NS ⁴³⁷
------------------------	-------	--------	----------	-------------------

325Ci

6 cyl. 2.5L FI (Convertible)	LC-8170	VFAP-7865	VCA-1162	
------------------------------	---------	-----------	----------	--

330Ci

6 cyl. 3.0L FI (M54)	LC-8170	VFAP-7865	VCA-1162	
----------------------	---------	-----------	----------	--

330i, 330Xi

L6 3.0L FI (N52)	VO-91	VA-323	VCA-1103	NS ⁴³⁷
------------------	-------	--------	----------	-------------------

525i, 525xi

6 cyl. 3.0L FI	VO-91	VA-337		NS ⁴³⁷
----------------	-------	--------	--	-------------------

530i, 530iT, 530xi

6 cyl. 3.0L FI	VO-91	VA-337		NS ⁴³⁷
----------------	-------	--------	--	-------------------

550i Series

V8 4.8L FI	VO-112	VA-364		NS ⁴³⁷
------------	--------	--------	--	-------------------

650i, 650i xDrive

V8 4.8L FI	VO-112	VA-364		NS ⁴³⁷
------------	--------	--------	--	-------------------

Se reporter à table de matière pour les notes en bas de page en français. Utilize el contenido para ver notas a pie.

NS - Non-Serviceable / Non réparable / No reparable LF - Life-Time Filter / Filtro para toda la vida / Filtre à vie

⁴³⁷ Requires replacement of the complete fuel pump/fuel filter module. ⁴⁵⁰ Lifetime filter. Does not require replacement under normal conditions.



BMW (cont'd)

	Oil	Air	Cabin*	Fuel
2006				
750i, 750i xDrive, 750Li, 750Li xDrive				
V8 4.8L	VO-112			
760i, 760Li				
V12 6.0L FI	VO-112			
M3				
6 cyl. 3.2L FI	VO-130	VFAP-7865	VCA-1162	
M5				
V10 5.0L FI				LF ⁴⁵⁰
X3				
6 cyl. 2.5L FI	LC-8170	VFAP-7865	VCA-1162	LF ⁴⁵⁰
6 cyl. 3.0L FI	LC-8170	VFAP-7865	VCA-1162	LF ⁴⁵⁰
X5				
6 cyl. 3.0L FI	LC-8170	VA-341	VCA-1156	
V8 4.4L FI	VO-128	VA-157	VCA-1156	
V8 4.8L FI	VO-128	VA-157	VCA-1156	
Z4				
6 cyl. 3.0L FI	VO-91	VA-367		NS ⁴³⁷
6 cyl. 3.2L FI	VO-130	VA-337		NS ⁴³⁷
2005				
320i Series				
6 cyl 2.2L FI (Canada)	LC-8170	VFAP-7865	VCA-1162	
325 Series				
6 cyl. 2.5L FI	LC-8170	VFAP-7865	VCA-1162	
330 Series				
6 cyl. 3.0L FI	LC-8170	VFAP-7865	VCA-1162	
525i, 525iT				
6 cyl. 2.5L FI	LC-8170	VA-337		NS ⁴³⁷
530i, 530iT, 530xi				
6 cyl. 3.0L FI	LC-8170	VA-337		NS ⁴³⁷
545i				
V8 4.4L FI	VO-128	VA-364		NS ⁴³⁷
645i				
V8 4.4L FI	VO-128	VA-364		NS ⁴³⁷
745i, 745Li				
V8 4.4L FI	VO-128			NS ⁴³⁷
760i, 760Li				
V12 6.0L FI	VO-112			
M3				
6 cyl. 3.2L FI	VO-130	VFAP-7865	VCA-1162	
X3				
6 cyl. 2.5L FI	LC-8170	VFAP-7865	VCA-1162	LF ⁴⁵⁰
6 cyl. 3.0L FI	LC-8170	VFAP-7865	VCA-1162	LF ⁴⁵⁰
X5				
6 cyl. 3.0L FI	LC-8170	VA-341	VCA-1156	
V8 4.4L FI	VO-128	VA-157	VCA-1156	
V8 4.8L FI	VO-128	VA-157	VCA-1156	
Z4				
6 cyl. 2.5L FI	LC-8170	VFAP-7865		NS ⁴³⁷
6 cyl. 3.0L FI	LC-8170	VFAP-7865		NS ⁴³⁷
2004				
320i Series				
6 cyl 2.2L FI (Canada)	LC-8170	VFAP-7865	VCA-1162	

Se reporter à table de matière pour les notes en bas de page en français. Utilize el contenido para ver notas a pie.

NS - Non-Serviceable / Non réparable / No reparable LF - Life-Time Filter / Filtro para toda la vida / Filtre à vie

⁴³⁷ Requires replacement of the complete fuel pump/fuel filter module. ⁴⁵⁰ Lifetime filter. Does not require replacement under normal conditions.



BMW (cont'd)

2004

325 Series

6 cyl. 2.5L FI	LC-8170	VFAP-7865	VCA-1162	
----------------	---------	-----------	----------	--

330 Series

6 cyl. 3.0L FI	LC-8170	VFAP-7865	VCA-1162	
----------------	---------	-----------	----------	--

525i, 525iT

6 cyl. 2.5L FI	LC-8170	VA-337		NS ⁴³⁷
----------------	---------	--------	--	-------------------

530i, 530iT, 530xi

6 cyl. 3.0L FI	LC-8170	VA-337		NS ⁴³⁷
----------------	---------	--------	--	-------------------

545i

V8 4.4L FI	VO-128	VA-364		NS ⁴³⁷
------------	--------	--------	--	-------------------

645i

V8 4.4L FI	VO-128	VA-364	VCA-1156	NS ⁴³⁷
------------	--------	--------	----------	-------------------

745i, 745Li

V8 4.4L FI	VO-128			NS ⁴³⁷
------------	--------	--	--	-------------------

760Li

V12 6.0L FI	VO-112			
-------------	--------	--	--	--

M3

6 cyl. 3.2L FI	VO-130	VFAP-7865	VCA-1162	
----------------	--------	-----------	----------	--

X3

6 cyl. 2.5L FI	LC-8170	VFAP-7865	VCA-1162	LF ⁴⁵⁰
----------------	---------	-----------	----------	-------------------

6 cyl. 3.0L FI	LC-8170	VFAP-7865	VCA-1162	LF ⁴⁵⁰
----------------	---------	-----------	----------	-------------------

X5

6 cyl. 3.0L FI	LC-8170	VA-341	VCA-1156	
----------------	---------	--------	----------	--

V8 4.4L FI	VO-128	VA-157	VCA-1156	
------------	--------	--------	----------	--

V8 4.8L FI	VO-128	VA-157	VCA-1156	
------------	--------	--------	----------	--

Z4

6 cyl. 2.5L FI	LC-8170	VFAP-7865		NS ⁴³⁷
----------------	---------	-----------	--	-------------------

6 cyl. 3.0L FI	LC-8170	VFAP-7865		NS ⁴³⁷
----------------	---------	-----------	--	-------------------

2003

320i Series

6 cyl 2.2L FI (Canada)	LC-8170	VFAP-7865	VCA-1162	
------------------------	---------	-----------	----------	--

325 Series

6 cyl. 2.5L FI	LC-8170	VFAP-7865	VCA-1162	
----------------	---------	-----------	----------	--

330 Series

6 cyl. 3.0L FI	LC-8170	VFAP-7865	VCA-1162	
----------------	---------	-----------	----------	--

525i, 525iT

6 cyl. 2.5L FI	LC-8170	VFAP-7865	VCA-1127	
----------------	---------	-----------	----------	--

530i, 530iT, 530xi

6 cyl. 3.0L FI	LC-8170	VFAP-7865	VCA-1127	
----------------	---------	-----------	----------	--

540i, 540iT

V8 4.4L FI	VO-74	VA-157	VCA-1127	
------------	-------	--------	----------	--

745i, 745Li

V8 4.4L FI	VO-128			NS ⁴³⁷
------------	--------	--	--	-------------------

760Li

V12 6.0L FI	VO-112			
-------------	--------	--	--	--

Alpine Roadster

V8 4.8L FI	VO-74	VA-157		
------------	-------	--------	--	--

M3

6 cyl. 3.2L FI	VO-130	VFAP-7865	VCA-1162	
----------------	--------	-----------	----------	--

M5

V8 5.0L FI	VO-74	VA-157	VCA-1127	
------------	-------	--------	----------	--

Se reporter à table de matière pour les notes en bas de page en français. Utilize el contenido para ver notas a pie.

NS - Non-Serviceable / Non réparable / No reparable LF - Life-Time Filter / Filtro para toda la vida / Filtre à vie

⁴³⁷ Requires replacement of the complete fuel pump/fuel filter module. ⁴⁵⁰ Lifetime filter. Does not require replacement under normal conditions.



BMW (cont'd)

	Oil	Air	Cabin*	Fuel
2003				
X5				
6 cyl. 3.0L FI	LC-8170	VA-341	VCA-1156	
V8 4.4L FI	VO-74	VA-157	VCA-1156	
V8 4.6L FI	VO-74	VA-157	VCA-1156	
Z4				
6 cyl. 2.5L FI	LC-8170	VFAP-7865		NS ⁴³⁷
6 cyl. 3.0L FI	LC-8170	VFAP-7865		NS ⁴³⁷
Z8				
V8 5.0L FI	VO-74	VA-157		
2002				
320i Series				
6 cyl. 2.2L FI (Canada)	LC-8170	VFAP-7865	VCA-1162	
325 Series				
6 cyl. 2.5L FI	LC-8170	VFAP-7865	VCA-1162	
330 Series				
6 cyl. 3.0L FI	LC-8170	VFAP-7865	VCA-1162	
525i, 525iT				
6 cyl. 2.5L FI	LC-8170	VFAP-7865	VCA-1127	
530i, 530iT, 530xi				
6 cyl. 3.0L FI	LC-8170	VFAP-7865	VCA-1127	
540i, 540iT				
V8 4.4L FI	VO-74	VA-157	VCA-1127	
745i				
V8 4.4L FI	VO-128			NS ⁴³⁷
M3				
6 cyl. 3.2L FI	LC-834	VFAP-7865	VCA-1162	
M5				
V8 5.0L FI	VO-74	VA-157	VCA-1127	
X5				
6 cyl. 3.0L FI	LC-8170	VA-341	VCA-1156	
V8 4.4L FI	VO-74	VA-157	VCA-1156	
V8 4.6L FI	VO-74	VA-157	VCA-1156	
Z3				
6 cyl. 2.5L FI	LC-8170	VFAP-7865		
6 cyl. 3.0L FI	LC-8170	VFAP-7865		
6 cyl. 3.2L FI	LC-834	VFAP-7865		
Z8				
V8 5.0L FI	VO-74	VA-157		
2001				
320i Series				
6 cyl. 2.2L FI (Canada)	LC-8170	VFAP-7865	VCA-1162	
325 Series				
6 cyl. 2.5L FI	LC-8170	VFAP-7865	VCA-1162	
330 Series				
6 cyl. 3.0L FI	LC-8170	VFAP-7865	VCA-1162	
525i, 525iT				
6 cyl. 2.5L FI	LC-8170	VFAP-7865	VCA-1127	
530i, 530iT, 530xi				
6 cyl. 3.0L FI	LC-8170	VFAP-7865	VCA-1127	
540i, 540iT				
V8 4.4L FI	VO-74	VA-157	VCA-1127	

Se reporter à table de matière pour les notes en bas de page en français. Utilize el contenido para ver notas a pie.

NS - Non-Serviceable / Non réparable / No reparable LF - Life-Time Filter / Filtro para toda la vida / Filtre à vie

⁴³⁷ Requires replacement of the complete fuel pump/fuel filter module.



BMW (cont'd)

2001

740i, 740iL

V8 4.4L FI	VO-74	VA-157		
------------	-------	--------	--	--

750iL

V12 5.4L FI	VO-74	VA-341 ¹¹²		
-------------	-------	-----------------------	--	--

M3

6 cyl. 3.2L FI	LC-834	VFAP-7865	VCA-1162	
----------------	--------	-----------	----------	--

M5

V8 5.0L FI	VO-74	VA-157	VCA-1127	
------------	-------	--------	----------	--

X5

6 cyl. 3.0L FI	LC-8170	VA-341	VCA-1156	
----------------	---------	--------	----------	--

V8 4.4L FI	VO-74	VA-157	VCA-1156	
------------	-------	--------	----------	--

Z3

6 cyl. 2.5L FI	LC-8170	VFAP-7865		
----------------	---------	-----------	--	--

6 cyl. 3.0L FI	LC-8170	VFAP-7865		
----------------	---------	-----------	--	--

6 cyl. 3.2L FI	LC-834	VFAP-7865		
----------------	--------	-----------	--	--

Z8

V8 5.0L FI	VO-74	VA-157		
------------	-------	--------	--	--

2000

323 Series

6 cyl. 2.5L FI	LC-8170	VFAP-7865	VCA-1162	
----------------	---------	-----------	----------	--

328 Series

6 cyl. 2.8L FI	LC-8170	VFAP-7865	VCA-1162	
----------------	---------	-----------	----------	--

528 Series

6 cyl. 2.8L FI	LC-8170	VFAP-7865	VCA-1127	
----------------	---------	-----------	----------	--

540i, 540iT

V8 4.4L FI	VO-74	VA-157	VCA-1127	
------------	-------	--------	----------	--

740i, 740iL

V8 4.4L FI	VO-74	VA-157		
------------	-------	--------	--	--

750iL

V12 5.4L FI	VO-74	VA-341 ¹¹²		
-------------	-------	-----------------------	--	--

M5

V8 5.0L FI	VO-74	VA-157	VCA-1127	
------------	-------	--------	----------	--

X5

V8 4.4L FI	VO-74	VA-157	VCA-1156	
------------	-------	--------	----------	--

Z3

6 cyl. 2.5L FI	LC-8170	VFAP-7865		
----------------	---------	-----------	--	--

6 cyl. 2.8L FI	LC-8170	VFAP-7865		
----------------	---------	-----------	--	--

6 cyl. 3.2L FI	LC-834	VFAP-7865		
----------------	--------	-----------	--	--

Z8

V8 5.0L FI	VO-74	VA-157		
------------	-------	--------	--	--

1999

318ti

4 cyl. 1.9L FI	LC-8445			
----------------	---------	--	--	--

318i, 318is

4 cyl. 1.9L FI	LC-8445			
----------------	---------	--	--	--

323 Series

6 cyl. 2.5L FI	LC-8170	VFAP-7865	VCA-1162	
----------------	---------	-----------	----------	--

328 Series

6 cyl. 2.8L FI	LC-8170	VFAP-7865	VCA-1162	
----------------	---------	-----------	----------	--

528 Series

6 cyl. 2.8L FI	LC-8170	VFAP-7865	VCA-1127	
----------------	---------	-----------	----------	--

Se reporter à table de matière pour les notes en bas de page en français. Utilize el contenido para ver notas a pie.

NS - Non-Serviceable / Non réparable / No reparable LF - Life-Time Filter / Filtro para toda la vida / Filtre à vie

¹¹² Requires two (2).



BMW (cont'd)

	Oil	Air	Cabin*	Fuel
1999				
540i, 540iT				
V8 4.4L FI	VO-74	VA-157	VCA-1127	
740i, 740iL				
V8 4.4L FI	VO-74	VA-157		
750iL				
V12 5.4L FI	VO-74	VA-341 ¹¹²		
M3				
6 cyl. 3.2L FI	LC-834	VFAP-7865	VCA-1162	
Z3				
6 cyl. 2.5L FI	LC-8170	VFAP-7865		
6 cyl. 2.8L FI	LC-8170	VFAP-7865		
6 cyl. 3.2L FI	LC-834	VFAP-7865		
1998				
318ti				
4 cyl. 1.9L FI	LC-8445			
318i,318is				
4 cyl. 1.9L FI	LC-8445			
323 Series				
6 cyl. 2.5L FI	LC-8170	VFAP-7865		
328 Series				
6 cyl. 2.8L FI	LC-8170	VFAP-7865		
528 Series				
6 cyl. 2.8L FI	LC-8170	VFAP-7865	VCA-1127	
540i				
V8 4.4L FI	VO-74	VA-157	VCA-1127	
740i, 740iL				
V8 4.4L FI	VO-74	VA-157		
750iL				
V12 5.4L FI	VO-74	VA-341 ¹¹²		
M3				
6 cyl. 3.2L FI	LC-834	VFAP-7865		
Z3				
4 cyl. 1.9L FI	LC-8445			
6 cyl. 2.8L FI	LC-8170	VFAP-7865		
6 cyl. 3.2L FI	LC-834	VFAP-7865		
1997				
318ti				
4 cyl. 1.9L FI	LC-8445			
318i,318is				
4 cyl. 1.9L FI	LC-8445			
328 Series				
6 cyl. 2.8L FI	LC-8170	VFAP-7865		
528 Series				
6 cyl. 2.8L FI	LC-8170	VFAP-7865	VCA-1127	
540i				
V8 4.4L FI	VO-74	VA-157	VCA-1127	
740i, 740iL				
V8 4.4L FI	VO-74	VA-157		
750iL				
V12 5.4L FI	VO-74	VA-341 ¹¹²		
840Ci				
V8 4.4L FI	VO-74	VA-157		

Se reporter à table de matière pour les notes en bas de page en français. Utilize el contenido para ver notas a pie.

NS - Non-Serviceable / Non réparable / No reparable LF - Life-Time Filter / Filtro para toda la vida / Filtre à vie

¹¹² Requires two (2).



BMW (cont'd)

1997

850Ci

V12 5.4L FI	VO-74	VA-389 ¹¹²		
-------------	-------	-----------------------	--	--

M3

6 cyl. 3.2L FI	LC-834	VFAP-7865		
----------------	--------	-----------	--	--

Z3

4 cyl. 1.9L FI	LC-8445			
----------------	---------	--	--	--

6 cyl. 2.8L FI	LC-8170	VFAP-7865		
----------------	---------	-----------	--	--

1996

318ti

4 cyl. 1.9L FI	LC-8445			
----------------	---------	--	--	--

318i,318is

4 cyl. 1.9L FI	LC-8445			
----------------	---------	--	--	--

328 Series

6 cyl. 2.8L FI	LC-8170	VFAP-7865		
----------------	---------	-----------	--	--

740i, 740iL

V8 4.4L FI	VO-74	VA-157		
------------	-------	--------	--	--

750iL

V12 5.4L FI	VO-74	VA-341 ¹¹²		
-------------	-------	-----------------------	--	--

840Ci

V8 4.4L FI	VO-74	VA-157		
------------	-------	--------	--	--

850Ci

V12 5.4L FI	VO-74	VA-389 ¹¹²		
-------------	-------	-----------------------	--	--

M3

6 cyl. 3.2L FI	LC-834	VFAP-7865		
----------------	--------	-----------	--	--

Z3

4 cyl. 1.9L FI	LC-8445			
----------------	---------	--	--	--

1995

318i,318is

4 cyl. 1.8L FI	LC-833			
----------------	--------	--	--	--

320i Series

6 cyl 2.0L FI (Canada)	LC-834	VFAP-7865	VCA-1162	
------------------------	--------	-----------	----------	--

325i Series

6 cyl. 2.5L FI	LC-834	VFAP-7865		
----------------	--------	-----------	--	--

525i, 525iT

6 cyl. 2.5L FI	LC-834	VA-395		
----------------	--------	--------	--	--

530i Series

V8 3.0L FI		VA-157		
------------	--	--------	--	--

540i

V8 4.0L FI		VA-157		
------------	--	--------	--	--

740i, 740iL

V8 4.0L FI		VA-157		
------------	--	--------	--	--

750iL

V12 5.4L FI		VA-389 ¹¹²		
-------------	--	-----------------------	--	--

840Ci

V8 4.0L FI		VA-157		
------------	--	--------	--	--

850Ci

V12 5.4L FI	VO-74	VA-389 ¹¹²		
-------------	-------	-----------------------	--	--

850csi

V12 5.6L FI		VA-389 ¹¹²		
-------------	--	-----------------------	--	--

M3

6 cyl. 3.0L FI	LC-834	VFAP-7865		
----------------	--------	-----------	--	--

Se reporter à table de matière pour les notes en bas de page en français. Utilize el contenido para ver notas a pie.

NS - Non-Serviceable / Non réparable / No reparable LF - Life-Time Filter / Filtro para toda la vida / Filtre à vie

¹¹² Requires two (2).



BUICK

	Oil	Air	Cabin*	Fuel
2019				
Cascada				
4 cyl. 1.6	VO-98	VA-296	VCA-1078C ^{X401} VCA-1078 ^{Z401}	NS ⁴³⁷
Enclave				
V6 3.6L	VO-88	VA-467	VCA-1184	NS ⁴³⁷
Encore				
4 cyl. 1.4L (M) Turbo	VO-200	VA-424	VCA-1078C ^{X401} VCA-1078 ^{Z401}	NS ⁴³⁷
4 cyl. 1.4L (B) Turbo	VO-98 ^{X907} VO-173 ^{Z907}	VA-424	VCA-1078C ^{X401} VCA-1078 ^{Z401}	NS ⁴³⁷
Envision				
4 cyl. 2.0 Turbo	VO-200	VA-468	VCA-1184	NS ⁴³⁷
4 cyl. 2.5L	VO-200	VA-468	VCA-1184	NS ⁴³⁷
Lacrosse				
4 cyl. 2.5L	VO-200	VA-459	VCA-1184	NS ⁴³⁷
V6 3.6L	VO-201		VCA-1184	NS ⁴³⁷
Regal Sportback				
4 cyl. 2.0L Turbo	VO-200		VCA-1184	NS ⁴³⁷
V6 3.6L	VO-201		VCA-1184	NS ⁴³⁷
Regal TourX				
4 cyl. 2.0L Turbo	VO-200		VCA-1184	NS ⁴³⁷
2018				
Cascada				
4 cyl. 1.6	VO-98	VA-296	VCA-1078C ^{X401} VCA-1078 ^{Z401}	NS ⁴³⁷
Enclave				
V6 3.6L	VO-88	VA-467	VCA-1184	NS ⁴³⁷
Encore				
4 cyl. 1.4L (M) Turbo	VO-200	VA-424	VCA-1078C ^{X401} VCA-1078 ^{Z401}	NS ⁴³⁷
4 cyl. 1.4L (B) Turbo	VO-98 ^{X907} VO-173 ^{Z907}	VA-424	VCA-1078C ^{X401} VCA-1078 ^{Z401}	NS ⁴³⁷
Envision				
4 cyl. 2.0 Turbo	VO-200	VA-468	VCA-1184	NS ⁴³⁷
4 cyl. 2.5L	VO-200	VA-468	VCA-1184	NS ⁴³⁷
Lacrosse				
4 cyl. 2.5L	VO-200	VA-459	VCA-1184	NS ⁴³⁷
V6 3.6L	VO-201		VCA-1184	NS ⁴³⁷
Regal Sportback				
4 cyl. 2.0L Turbo	VO-200		VCA-1184	NS ⁴³⁷
V6 3.6L	VO-201		VCA-1184	NS ⁴³⁷
Regal TourX				
4 cyl. 2.0L Turbo	VO-200		VCA-1184	NS ⁴³⁷
2017				
Cascada				
4 cyl. 1.6	VO-98	VA-296	VCA-1078C ^{X401} VCA-1078 ^{Z401}	NS ⁴³⁷
Enclave				
V6 3.6L	VO-88	VA-225	VCA-1080	NS ⁴³⁷

Se reporter à table de matière pour les notes en bas de page en français. Utilize el contenido para ver notas a pie.

NS - Non-Serviceable / Non réparable / No reparable LF - Life-Time Filter / Filtro para toda la vida / Filtre à vie

⁴³⁷ Requires replacement of the complete fuel pump/fuel filter module. ^{X401} Dust and Odor filter ^{X907} With oil filter housing marked Hengst. ^{Z401} Dust filter

^{Z907} With oil filter housing marked UFI



BUICK (cont'd)

2017

Encore

4 cyl. 1.4L (M) Turbo	VO-200	VA-424	VCA-1078C ^{X401} VCA-1078 ^{Z401}	NS ⁴³⁷
4 cyl. 1.4L (B) Turbo	VO-98 ^{X907} VO-173 ^{Z907}	VA-424	VCA-1078C ^{X401} VCA-1078 ^{Z401}	NS ⁴³⁷

Envision

4 cyl. 2.0 Turbo	VO-200	VA-468	VCA-1184	NS ⁴³⁷
4 cyl. 2.5L	VO-200	VA-468	VCA-1184	NS ⁴³⁷

Lacrosse

V6 3.6L	VO-201		VCA-1184	NS ⁴³⁷
---------	--------	--	----------	-------------------

Regal

4 cyl. 2.0L Turbo	VO-200	VA-308	VCA-1078C ^{X401} VCA-1078 ^{Z401}	NS ⁴³⁷
4 cyl. 2.4L (Flex Fuel)	VO-76	VA-254	VCA-1078C ^{X401} VCA-1078 ^{Z401}	NS ⁴³⁷

Verano

4 cyl. 2.4L (Flex Fuel)	VO-76	VA-296	VCA-1078C ^{X401} VCA-1078 ^{Z401}	NS ⁴³⁷
-------------------------	-------	--------	---	-------------------

2016

Cascada

4 cyl. 1.6	VO-98	VA-296	VCA-1078C ^{X401} VCA-1078 ^{Z401}	NS ⁴³⁷
------------	-------	--------	---	-------------------

Enclave

V6 3.6L	VO-88	VA-225	VCA-1080	NS ⁴³⁷
---------	-------	--------	----------	-------------------

Encore

4 cyl. 1.4L Turbo	VO-98 ^{X907} VO-173 ^{Z907}	VA-424	VCA-1078C ^{X401} VCA-1078 ^{Z401}	NS ⁴³⁷
-------------------	---	--------	---	-------------------

Encore Sport Touring

4 cyl. 1.4L (M) Turbo	VO-160	VA-424	VCA-1078C ^{X401} VCA-1078 ^{Z401}	NS ⁴³⁷
-----------------------	--------	--------	---	-------------------

Envision

4 cyl. 2.0 Turbo	VO-200	VA-468	VCA-1184	NS ⁴³⁷
------------------	--------	--------	----------	-------------------

Lacrosse

4 cyl. 2.4L Hybrid	VO-76	VA-254	VCA-1078C ^{X401} VCA-1078 ^{Z401}	NS ⁴³⁷
V6 3.6L	VO-88	VA-308	VCA-1078C ^{X401} VCA-1078 ^{Z401}	NS ⁴³⁷

Regal

4 cyl. 2.0L Turbo	VO-200	VA-308	VCA-1078C ^{X401} VCA-1078 ^{Z401}	NS ⁴³⁷
4 cyl. 2.4L (Flex Fuel)	VO-76	VA-254	VCA-1078C ^{X401} VCA-1078 ^{Z401}	NS ⁴³⁷
4 cyl. 2.4L Hybrid	VO-76	VA-254	VCA-1078C ^{X401} VCA-1078 ^{Z401}	NS ⁴³⁷

Verano

4 cyl. 2.0L Turbo	VO-76	VA-285	VCA-1078C ^{X401} VCA-1078 ^{Z401}	NS ⁴³⁷
4 cyl. 2.4L (Flex Fuel)	VO-76	VA-296	VCA-1078C ^{X401} VCA-1078 ^{Z401}	NS ⁴³⁷

Se reporter à table de matière pour les notes en bas de page en français. Utilize el contenido para ver notas a pie.

NS - Non-Serviceable / Non réparable / No reparable LF - Life-Time Filter / Filtro para toda la vida / Filtre à vie

⁴³⁷ Requires replacement of the complete fuel pump/fuel filter module. ^{X401}Dust and Odor filter ^{X907}With oil filter housing marked Hengst. ^{Z401}Dust filter

^{Z907}With oil filter housing marked UFI



BUICK (cont'd)

2015				
Enclave				
V6 3.6L	VO-88	VA-225	VCA-1080	NS ⁴³⁷
Encore				
4 cyl. 1.4L Turbo	VO-98 ^{X907} VO-173 ^{Z907}	VA-424	VCA-1078C ^{X401} VCA-1078 ^{Z401}	NS ⁴³⁷
Lacrosse				
4 cyl. 2.4L Hybrid	VO-76	VA-254	VCA-1078C ^{X401} VCA-1078 ^{Z401}	NS ⁴³⁷
V6 3.6L	VO-88	VA-308	VCA-1078C ^{X401} VCA-1078 ^{Z401}	NS ⁴³⁷
Regal				
4 cyl. 2.0L Turbo	VO-200	VA-308	VCA-1078C ^{X401} VCA-1078 ^{Z401}	NS ⁴³⁷
4 cyl. 2.4L (Flex Fuel)	VO-76	VA-254	VCA-1078C ^{X401} VCA-1078 ^{Z401}	NS ⁴³⁷
4 cyl. 2.4L (R) Hybrid	VO-76	VA-254	VCA-1078C ^{X401} VCA-1078 ^{Z401}	NS ⁴³⁷
Verano				
4 cyl 2.0L Turbo	VO-76	VA-285	VCA-1078C ^{X401} VCA-1078 ^{Z401}	NS ⁴³⁷
4 cyl 2.4L (Flex Fuel)	VO-76	VA-296	VCA-1078C ^{X401} VCA-1078 ^{Z401}	NS ⁴³⁷
2014				
Enclave				
V6 3.6L	VO-88	VA-225	VCA-1080	NS ⁴³⁷
Encore				
4 cyl. 1.4L Turbo	VO-98 ^{X907} VO-173 ^{Z907}	VA-424	VCA-1078C ^{X401} VCA-1078 ^{Z401}	NS ⁴³⁷
Lacrosse				
4 cyl. 2.4L Hybrid	VO-76	VA-254	VCA-1078C ^{X401} VCA-1078 ^{Z401}	NS ⁴³⁷
V6 3.6L	VO-88	VA-308	VCA-1078C ^{X401} VCA-1078 ^{Z401}	NS ⁴³⁷
Regal				
4 cyl. 2.0L Turbo	VO-200	VA-308	VCA-1078C ^{X401} VCA-1078 ^{Z401}	NS ⁴³⁷
4 cyl. 2.4L Hybrid	VO-76	VA-254	VCA-1078C ^{X401} VCA-1078 ^{Z401}	NS ⁴³⁷
Verano				
4 cyl 2.0L Turbo	VO-76	VA-285	VCA-1078C ^{X401} VCA-1078 ^{Z401}	NS ⁴³⁷
4 cyl 2.4L (Flex Fuel)	VO-76	VA-296	VCA-1078C ^{X401} VCA-1078 ^{Z401}	NS ⁴³⁷
2013				
Enclave				
V6 3.6L	VO-88	VA-225	VCA-1080	NS ⁴³⁷
Encore				
4 cyl. 1.4L Turbo	VO-98 ^{X907} VO-173 ^{Z907}	VA-424	VCA-1078C ^{X401} VCA-1078 ^{Z401}	NS ⁴³⁷

Se reporter à table de matière pour les notes en bas de page en français. Utilize el contenido para ver notas a pie.

NS - Non-Serviceable / Non réparable / No reparable LF - Life-Time Filter / Filtro para toda la vida / Filtre à vie

⁴³⁷ Requires replacement of the complete fuel pump/fuel filter module. ^{X401}Dust and Odor filter ^{X907}With oil filter housing marked Hengst. ^{Z401}Dust filter

^{Z907}With oil filter housing marked UFI



BUICK (cont'd)

2013

Lacrosse

4 cyl. 2.4L Hybrid	VO-76	VA-254	VCA-1078C ^{X401} VCA-1078 ^{Z401}	NS ⁴³⁷
V6 3.6L	VO-88	VA-254	VCA-1078C ^{X401} VCA-1078 ^{Z401}	NS ⁴³⁷

Regal

4 cyl. 2.0L Turbo	VO-76	VA-254	VCA-1078C ^{X401} VCA-1078 ^{Z401}	NS ⁴³⁷
4 cyl. 2.4L Hybrid	VO-76	VA-254	VCA-1078C ^{X401} VCA-1078 ^{Z401}	NS ⁴³⁷

Verano

4 cyl 2.0L Turbo	VO-76	VA-285	VCA-1078C ^{X401} VCA-1078 ^{Z401}	NS ⁴³⁷
4 cyl 2.4L (Flex Fuel)	VO-76	VA-296	VCA-1078C ^{X401} VCA-1078 ^{Z401}	NS ⁴³⁷

2012

Enclave

V6 3.6L	VO-88	VA-225	VCA-1080	NS ⁴³⁷
---------	-------	--------	----------	-------------------

Lacrosse

4 cyl. 2.4L Hybrid	VO-76	VA-254	VCA-1078C ^{X401} VCA-1078 ^{Z401}	NS ⁴³⁷
V6 3.6L (Flex Fuel)	VO-88	VA-254	VCA-1078C ^{X401} VCA-1078 ^{Z401}	NS ⁴³⁷

Regal

4 cyl. 2.0L Turbo	VO-76	VA-254	VCA-1078C ^{X401} VCA-1078 ^{Z401}	NS ⁴³⁷
4 cyl. 2.4L (Flex Fuel)	VO-76	VA-254	VCA-1078C ^{X401} VCA-1078 ^{Z401}	NS ⁴³⁷
4 cyl. 2.4L Hybrid	VO-76	VA-254	VCA-1078C ^{X401} VCA-1078 ^{Z401}	NS ⁴³⁷

Verano

4 cyl 2.4L (Flex Fuel)	VO-76	VA-296	VCA-1078C ^{X401} VCA-1078 ^{Z401}	NS ⁴³⁷
------------------------	-------	--------	---	-------------------

2011

Enclave

V6 3.6L	VO-88	VA-225	VCA-1080	NS ⁴³⁷
---------	-------	--------	----------	-------------------

Lacrosse

4 cyl. 2.4L	VO-76	VA-254	VCA-1078C ^{X401} VCA-1078 ^{Z401}	NS ⁴³⁷
V6 3.6L	VO-88	VA-254	VCA-1078C ^{X401} VCA-1078 ^{Z401}	NS ⁴³⁷

Lucerne

V6 3.9L (M) FI (Flex Fuel)	VO-108	VA-176	VCA-1022 ^{X019} VCA-1165 ^{Z019}	NS ⁴³⁷
V8 4.6L (S) FI	VO-108	VA-176	VCA-1022 ^{X019} VCA-1165 ^{Z019}	NS ⁴³⁷

Regal

4 cyl. 2.0L Turbo	VO-76	VA-254	VCA-1078C ^{X401} VCA-1078 ^{Z401}	NS ⁴³⁷
4 cyl. 2.4L	VO-76	VA-254	VCA-1078C ^{X401} VCA-1078 ^{Z401}	NS ⁴³⁷

Se reporter à table de matière pour les notes en bas de page en français. Utilize el contenido para ver notas a pie.

NS - Non-Serviceable / Non réparable / No reparable LF - Life-Time Filter / Filtro para toda la vida / Filtre à vie

⁴³⁷ Requires replacement of the complete fuel pump/fuel filter module. ^{X019}Dust filter. ^{X401}Dust and Odor filter ^{Z019}Dust and odor filter. ^{Z401}Dust filter



BUICK (cont'd)

	Oil	Air	Cabin*	Fuel
2010				
Allure (Canada)				
4 cyl. 2.4L (C) FI	VO-76	VA-254	VCA-1078C ^{X401} VCA-1078 ^{Z401}	NS ⁴³⁷
V6 3.0L (G) FI	VO-88	VA-254	VCA-1078C ^{X401} VCA-1078 ^{Z401}	NS ⁴³⁷
V6 3.6L (V) FI	VO-88	VA-254	VCA-1078C ^{X401} VCA-1078 ^{Z401}	NS ⁴³⁷
Enclave				
V6 3.6L	VO-88	VA-225	VCA-1080	NS ⁴³⁷
Lacrosse				
4 cyl. 2.4L	VO-76	VA-254	VCA-1078C ^{X401} VCA-1078 ^{Z401}	NS ⁴³⁷
V6 3.0L	VO-88	VA-254	VCA-1078C ^{X401} VCA-1078 ^{Z401}	NS ⁴³⁷
V6 3.6L	VO-88	VA-254	VCA-1078C ^{X401} VCA-1078 ^{Z401}	NS ⁴³⁷
Lucerne				
V6 3.9L (1) FI	VO-108	VA-176	VCA-1022 ^{X019} VCA-1165 ^{Z019}	NS ⁴³⁷
V6 3.9L (M) FI (Flex Fuel)	VO-108	VA-176	VCA-1022 ^{X019} VCA-1165 ^{Z019}	NS ⁴³⁷
V8 4.6L (9) FI	VO-108	VA-176	VCA-1022 ^{X019} VCA-1165 ^{Z019}	NS ⁴³⁷
2009				
Allure (Canada)				
V6 3.8L (2) FI	VO-16	VA-78	VCA-1002	NS ⁴³⁷
V8 5.3L (C) FI	VO-88	VA-200	VCA-1002	NS ⁴³⁷
Enclave				
V6 3.6L	VO-88	VA-225	VCA-1080	NS ⁴³⁷
Lacrosse				
V6 3.8L (2) FI	VO-16	VA-78	VCA-1002	NS ⁴³⁷
V8 5.3L (C) FI	VO-88	VA-200	VCA-1002	NS ⁴³⁷
Lucerne				
V6 3.9L (1) FI	VO-108	VA-176	VCA-1022 ^{X019} VCA-1165 ^{Z019}	NS ⁴³⁷
V6 3.9L (M) FI (Flex Fuel)	VO-108	VA-176	VCA-1022 ^{X019} VCA-1165 ^{Z019}	NS ⁴³⁷
V8 4.6L (9) FI	VO-108	VA-176	VCA-1022 ^{X019} VCA-1165 ^{Z019}	NS ⁴³⁷
2008				
Allure (Canada)				
V6 3.6L (7) FI	VO-88	VA-78	VCA-1002	NS ⁴³⁷
V6 3.8L (2) FI	VO-16	VA-78	VCA-1002	NS ⁴³⁷
V8 5.3L (C) FI	VO-88	VA-200	VCA-1002	NS ⁴³⁷
Enclave				
V6 3.6L	VO-88	VA-225	VCA-1080	NS ⁴³⁷
Lacrosse				
V6 3.6L (7) FI	VO-88	VA-78	VCA-1002	NS ⁴³⁷
V6 3.8L (2) FI	VO-16	VA-78	VCA-1002	NS ⁴³⁷
V8 5.3L (C) FI	VO-88	VA-200	VCA-1002	NS ⁴³⁷
Lucerne				
V6 3.8L (2) FI	VO-16	VA-176	VCA-1022 ^{X019} VCA-1165 ^{Z019}	NS ⁴³⁷

Se reporter à table de matière pour les notes en bas de page en français. Utilize el contenido para ver notas a pie.

NS - Non-Serviceable / Non réparable / No reparable LF - Life-Time Filter / Filtro para toda la vida / Filtre à vie

⁴³⁷ Requires replacement of the complete fuel pump/fuel filter module. ^{X019}Dust filter. ^{X401}Dust and Odor filter ^{Z019}Dust and odor filter. ^{Z401}Dust filter



BUICK (cont'd)

2008

Lucerne

V8 4.6L (9,Y) FI	VO-108	VA-176	VCA-1022 ^{X019} VCA-1165 ^{Z019}	NS ⁴³⁷
------------------	--------	--------	--	-------------------

2007

Allure (Canada)

V6 3.6L (7) FI	VO-108	VA-78	VCA-1002	NS ⁴³⁷
V6 3.8L (2) FI	VO-16	VA-78	VCA-1002	NS ⁴³⁷

Lacrosse

V6 3.6L (7) FI	VO-108	VA-78	VCA-1002	NS ⁴³⁷
V6 3.8L (2) FI	VO-16	VA-78	VCA-1002	NS ⁴³⁷

Lucerne

V6 3.8L (2) FI	VO-16	VA-176	VCA-1022 ^{X019} VCA-1165 ^{Z019}	NS ⁴³⁷
V8 4.6L (Y) FI	VO-108	VA-176	VCA-1022 ^{X019} VCA-1165 ^{Z019}	NS ⁴³⁷

Rainier

6 cyl. 4.2L (S) FI	VO-108	VA-161		NS ⁴³⁷
V8 5.3L (M) FI	VO-88	VA-161		NS ⁴³⁷

Rendezvous

V6 3.5L (L) FI	VO-16	VA-109	VCA-1164	NS ⁴³⁷
----------------	-------	--------	----------	-------------------

Terraza

V6 3.9L (1) FI	VO-108	VA-109	VCA-1164	NS ⁴³⁷
V6 3.9L (W) FI (Flex Fuel)	VO-108	VA-109	VCA-1164	NS ⁴³⁷

2006

Allure (Canada)

V6 3.6L (7) FI	VO-108	VA-78	VCA-1002	NS ⁴³⁷
V6 3.8L (2) FI	VO-16	VA-78	VCA-1002	NS ⁴³⁷

Lacrosse

V6 3.6L (7) FI	VO-108	VA-78	VCA-1002	NS ⁴³⁷
V6 3.8L (2) FI	VO-16	VA-78	VCA-1002	NS ⁴³⁷

Lucerne

V6 3.8L (2) FI	VO-16	VA-176	VCA-1022 ^{X019} VCA-1165 ^{Z019}	NS ⁴³⁷
V8 4.6L (Y) FI	VO-108	VA-176	VCA-1022 ^{X019} VCA-1165 ^{Z019}	NS ⁴³⁷

Rainier

6 cyl. 4.2L (S) FI	VO-108	VA-161		NS ⁴³⁷
V8 5.3L (M) FI	VO-58	VA-161		NS ⁴³⁷

Rendezvous

V6 3.5L (L) FI	VO-16	VA-109	VCA-1164	NS ⁴³⁷
V6 3.6L (7) FI	VO-108	VA-109	VCA-1164	NS ⁴³⁷

Terraza

V6 3.5L (L) FI	VO-16	VA-109	VCA-1164	NS ⁴³⁷
V6 3.9L (1) FI	VO-108	VA-109	VCA-1164	NS ⁴³⁷

2005

Allure (Canada)

V6 3.6L (7) FI	VO-108	VA-78	VCA-1002	VG-33
V6 3.8L (2) FI	VO-16	VA-78	VCA-1002	VG-33

Century

V6 3.1L (J) FI	VO-16	VA-78	VCA-1002	VG-33
----------------	-------	-------	----------	-------

Lacrosse

V6 3.6L (7) FI	VO-108	VA-78	VCA-1002	VG-33
----------------	--------	-------	----------	-------

Se reporter à table de matière pour les notes en bas de page en français. Utilize el contenido para ver notas a pie.

NS - Non-Serviceable / Non réparable / No repairable LF - Life-Time Filter / Filtro para toda la vida / Filtre à vie

⁴³⁷ Requires replacement of the complete fuel pump/fuel filter module. ^{X019}Dust filter. ^{Z019}Dust and odor filter.



BUICK (cont'd)

	Oil	Air	Cabin*	Fuel
2005				
Lacrosse				
V6 3.8L (2) FI	VO-16	VA-78	VCA-1002	VG-33
LeSabre				
V6 3.8L (K) FI	VO-16	VA-78	VCA-1022 ^{X133} VCA-1022K ^{Z133} VCA-1165 ^{Y133}	VG-33
Park Avenue				
V6 3.8L (K) FI	VO-16	VA-78		VG-33
V6 3.8L (1) FI (S.C.)	VO-16	VA-78		VG-33
Rainier				
6 cyl. 4.2L (S) FI	VO-108	VA-161		NS ⁴³⁷
V8 5.3L (M) FI	VO-58	VA-161		NS ⁴³⁷
Rendezvous				
V6 3.4L (E) FI	VO-16	VA-109	VCA-1164	
V6 3.6L (7) FI	VO-108	VA-109	VCA-1164	
Terraza				
V6 3.5L (L) FI	VO-16	VA-109	VCA-1164	NS ⁴³⁷
2004				
Century				
V6 3.1L (J) FI	VO-16	VA-78	VCA-1002	VG-33
LeSabre				
V6 3.8L (K) FI	VO-16	VA-78	VCA-1022 ^{X133} VCA-1022K ^{Z133} VCA-1165 ^{Y133}	VG-33
Park Avenue				
V6 3.8L (K) FI	VO-16	VA-78		VG-33
V6 3.8L (1) FI (S.C.)	VO-16	VA-78		VG-33
Rainier				
6 cyl. 4.2L (S) FI	VO-108	VA-161		
V8 5.3L (P) FI	VO-58	VA-161		
Regal				
V6 3.8L (K) FI	VO-16	VA-78	VCA-1002	VG-33
V6 3.8L (1) FI (S.C.)	VO-16	VA-78	VCA-1002	VG-33
Rendezvous				
V6 3.4L (E) FI	VO-16	VA-109	VCA-1164	
V6 3.6L (7) FI	VO-108	VA-109	VCA-1164	
2003				
Century				
V6 3.1L (J) FI	VO-16	VA-78	VCA-1002	VG-33
LeSabre				
V6 3.8L (K) FI	VO-16	VA-78	VCA-1022 ^{X133} VCA-1022K ^{Z133} VCA-1165 ^{Y133}	VG-33
Park Avenue				
V6 3.8L (K) FI	VO-16	VA-78		VG-33
V6 3.8L (1) FI (S.C.)	VO-16	VA-78		VG-33
Regal				
V6 3.8L (K) FI	VO-16	VA-78	VCA-1002	VG-33
V6 3.8L (1) FI (S.C.)	VO-16	VA-78	VCA-1002	VG-33
Rendezvous				
V6 3.4L (E) FI	VO-16	VA-109	VCA-1164	

Se reporter à table de matière pour les notes en bas de page en français. Utilize el contenido para ver notas a pie.

NS - Non-Serviceable / Non réparable / No reparable LF - Life-Time Filter / Filtro para toda la vida / Filtre à vie

⁴³⁷ Requires replacement of the complete fuel pump/fuel filter module. ^{X133}Dust filter. ^{Y133}Dust and odor filter ^{Z133}Dust filter and housing.



BUICK (cont'd)

2002

Century

V6 3.1L (J) FI	VO-16	VA-78	VCA-1002	VG-33
----------------	-------	-------	----------	-------

LeSabre

V6 3.8L (K) FI	VO-16	VA-78	VCA-1022 ^{X133} VCA-1022K ^{Z133} VCA-1165 ^{Y133}	VG-33
----------------	-------	-------	---	-------

Park Avenue

V6 3.8L (K) FI	VO-16	VA-78		VG-33
V6 3.8L (1) FI (S.C.)	VO-16	VA-78		VG-33

Regal

V6 3.8L (K) FI	VO-16	VA-78	VCA-1002	VG-33
V6 3.8L (1) FI (S.C.)	VO-16	VA-78	VCA-1002	VG-33

Rendezvous

V6 3.4L (E) FI	VO-16	VA-109	VCA-1164	
----------------	-------	--------	----------	--

2001

Century

V6 3.1L (J) FI	VO-16	VA-78	VCA-1002	VG-33
----------------	-------	-------	----------	-------

LeSabre

V6 3.8L (K) FI	VO-16	VA-78	VCA-1022 ^{X133} VCA-1022K ^{Z133} VCA-1165 ^{Y133}	VG-33
----------------	-------	-------	---	-------

Park Avenue

V6 3.8L (K) FI	VO-16	VA-78		VG-33
V6 3.8L (1) FI (S.C.)	VO-16	VA-78		VG-33

Regal

V6 3.8L (K) FI	VO-16	VA-78	VCA-1002	VG-33
V6 3.8L (1) FI (S.C.)	VO-16	VA-78	VCA-1002	VG-33

2000

Century

V6 3.1L (J) FI	VO-16	VA-78	VCA-1002	VG-33
----------------	-------	-------	----------	-------

LeSabre

V6 3.8L (K) FI	VO-16	VA-78	VCA-1022 ^{X133} VCA-1022K ^{Z133} VCA-1165 ^{Y133}	VG-33
----------------	-------	-------	---	-------

Park Avenue

V6 3.8L (K) FI	VO-16	VA-78		VG-33
V6 3.8L (1) FI (S.C.)	VO-16	VA-78		VG-33

Regal

V6 3.8L (K) FI	VO-16	VA-78	VCA-1002	VG-33
V6 3.8L (1) FI (S.C.)	VO-16	VA-78	VCA-1002	VG-33

1999

Century

V6 3.1L (M) FI	VO-16	VA-78	VCA-1002	VG-33
----------------	-------	-------	----------	-------

LeSabre

V6 3.8L (K) FI	VO-16	VA-78		VG-33
----------------	-------	-------	--	-------

Park Avenue

V6 3.8L (K) FI	VO-16	VA-78		VG-33
V6 3.8L (1) FI (S.C.)	VO-16	VA-78		VG-33

Regal

V6 3.8L (K) FI	VO-16	VA-78	VCA-1002	VG-33
V6 3.8L (1) FI (S.C.)	VO-16	VA-78	VCA-1002	VG-33

Se reporter à table de matière pour les notes en bas de page en français. Utilize el contenido para ver notas a pie.

NS - Non-Serviceable / Non réparable / No reparable. LF - Life-Time Filter / Filtro para toda la vida / Filtre à vie

^{X133}Dust filter. ^{Y133}Dust and odor filter ^{Z133}Dust filter and housing.



BUICK (cont'd)

	Oil	Air	Cabin*	Fuel
1999				
Riviera				
V6 3.8L (1) FI (S.C.)	VO-16	VA-78		VG-33
1998				
Century				
V6 3.1L (M) FI	VO-16	VA-109	VCA-1002	VG-33
LeSabre				
V6 3.8L (K) FI	VO-16	VA-78		VG-33
Park Avenue				
V6 3.8L (K) FI	VO-16	VA-78		VG-33
V6 3.8L (1) FI (S.C.)	VO-16	VA-78		VG-33
Regal				
V6 3.8L (K) FI	VO-16	VA-109	VCA-1002	VG-33
V6 3.8L (1) FI (S.C.)	VO-16	VA-109	VCA-1002	VG-33
Riviera				
V6 3.8L (1) FI (S.C.)	VO-16	VA-78		VG-33
Skylark				
4 cyl. 2.4L (T) FI	VO-58	VA-110		VG-33
V6 3.1L (M) FI	VO-16	VA-110		VG-33
1997				
Century				
V6 3.1L (M) FI	VO-16	VA-109	VCA-1002	VG-33
LeSabre				
V6 3.8L (K) FI	VO-16	VA-78		VG-33
Park Avenue				
V6 3.8L (K) FI	VO-16	VA-78		VG-33
V6 3.8L (1) FI (S.C.)	VO-16	VA-78		VG-33
Regal				
V6 3.8L (K) FI	VO-16	VA-109	VCA-1002	VG-33
V6 3.8L (1) FI (S.C.)	VO-16	VA-109	VCA-1002	VG-33
Riviera				
V6 3.8L (K) FI	VO-16	VA-78		VG-33
V6 3.8L (1) FI (S.C.)	VO-16	VA-78		VG-33
Skylark				
4 cyl. 2.4L (T) FI	VO-58	VA-110		VG-33
V6 3.1L (M) FI	VO-16	VA-110		VG-33
1996				
Century				
4 cyl. 2.2L (4) FI	VO-16			
V6 3.1L (M) FI	VO-16	VA-85		
LeSabre				
V6 3.8L (K) FI	VO-16	VA-78		VG-33
Park Avenue				
V6 3.8L (K) FI	VO-16	VA-78		VG-33
V6 3.8L (1) FI (S.C.)	VO-16	VA-78		VG-33
Regal				
V6 3.1L (M) FI	VO-16	VA-109		VG-33
V6 3.8L (K) FI	VO-16	VA-109		VG-33
Riviera				
V6 3.8L (K) FI	VO-16	VA-78		VG-33
V6 3.8L (1) FI (S.C.)	VO-16	VA-78		VG-33
Roadmaster				
V8 5.7L (P) FI	VO-55	VA-78		VG-30 ³⁹⁴

Se reporter à table de matière pour les notes en bas de page en français. Utilize el contenido para ver notas a pie.

NS - Non-Serviceable / Non réparable / No reparable LF - Life-Time Filter / Filtro para toda la vida / Filtre à vie

³⁹⁴ w/o bracket.



BUICK (cont'd)

1996

Skylark

4 cyl. 2.4L (T) FI	VO-58	VA-110		VG-33
V6 3.1L (M) FI	VO-16	VA-110		VG-33

1995

Century

4 cyl. 2.2L (4)	VO-16			
V6 3.1L (M) FI	VO-16	VA-85		

LeSabre

V6 3.8L (L)	VO-16	VA-78		VG-33
-------------	-------	-------	--	-------

Park Avenue

V6 3.8L (K)	VO-16	VA-78		VG-33
V6 3.8L (1) (S.C.)	VO-16	VA-78		VG-33

Regal

V6 3.1L (M) FI	VO-16	VA-109		VG-33
V6 3.8L (L) FI	VO-16	VA-109		VG-33

Riviera

V6 3.8L (K)	VO-16	VA-78		VG-33
V6 3.8L (1) (S.C.)	VO-16	VA-78		VG-33

Roadmaster

V8 5.7L (P) FI	VO-55	VA-78		VG-30 ³⁹⁴
----------------	-------	-------	--	----------------------

Skylark

4 cyl. 2.3L (D)	VO-16	VA-110		VG-33
V6 3.1L (M)	VO-16	VA-110		VG-33

CADILLAC

2019

ATS

4 cyl. 2.0L Turbo	VO-200	VA-457	VCA-1184	
V6 3.6L Non turbo	VO-201	VA-457	VCA-1184	
V6 3.6L Turbo	VO-201	VA-471 ¹¹²	VCA-1184	

CT6

4 cyl. 2.0L Turbo	VO-200		VCA-1184	NS ⁴³⁷
V6 3.0L Turbo	VO-201		VCA-1184	NS ⁴³⁷
V6 3.6L	VO-201		VCA-1184	NS ⁴³⁷
V8 4.2L Turbo	VO-88		VCA-1184	NS ⁴³⁷

CTS

4 cyl. 2.0L Turbo	VO-200	VA-457	VCA-1184	
V6 3.6L (S)	VO-201	VA-457	VCA-1184	NS ⁴³⁷
V6 3.6L (8) Turbo	VO-201		VCA-1184	NS ⁴³⁷
V8 6.2L (6) (S.C.)	VO-200		VCA-1184	NS ⁴³⁷

Escalade, Escalade ESV

V8 6.2L	VO-88	VA-324	VCA-1173	NS ⁴³⁷
---------	-------	--------	----------	-------------------

XT4

4 cyl. 2.0L Turbo	VO-202		VCA-1184	NS ⁴³⁷
-------------------	--------	--	----------	-------------------

XT5

V6 3.6	VO-201	VA-467	VCA-1184	NS ⁴³⁷
--------	--------	--------	----------	-------------------

XTS

V6 3.6L Non turbo	VO-88	VA-308	VCA-1184	NS ⁴³⁷
V6 3.6L Turbo	VO-88		VCA-1184	NS ⁴³⁷

2018

ATS

4 cyl. 2.0L Turbo	VO-200	VA-457	VCA-1184	
V6 3.6L Non turbo	VO-201	VA-457	VCA-1184	

Se reporter à table de matière pour les notes en bas de page en français. Utilize el contenido para ver notas a pie.

NS - Non-Serviceable / Non réparable / No repairable LF - Life-Time Filter / Filtro para toda la vida / Filtre à vie

¹¹² Requires two (2). ³⁹⁴ w/o bracket. ⁴³⁷ Requires replacement of the complete fuel pump/fuel filter module.



CADILLAC (cont'd)

	Oil	Air	Cabin*	Fuel
2018				
ATS				
V6 3.6L Turbo	VO-201	VA-471 ¹¹²	VCA-1184	
CT6				
4 cyl. 2.0L Turbo	VO-200		VCA-1184	NS ⁴³⁷
V6 3.0L Turbo	VO-201		VCA-1184	NS ⁴³⁷
V6 3.6L	VO-201		VCA-1184	NS ⁴³⁷
CTS				
4 cyl. 2.0L Turbo	VO-200	VA-457	VCA-1184	
V6 3.6L (S)	VO-201	VA-457	VCA-1184	NS ⁴³⁷
V6 3.6L (8) Turbo	VO-201		VCA-1184	NS ⁴³⁷
V8 6.2L (6) (S.C.)	VO-200		VCA-1184	NS ⁴³⁷
Escalade, Escalade ESV				
V8 6.2L	VO-88	VA-324	VCA-1173	NS ⁴³⁷
XT5				
V6 3.6	VO-201	VA-467	VCA-1184	NS ⁴³⁷
XTS				
V6 3.6L Non turbo	VO-88	VA-308	VCA-1184	NS ⁴³⁷
V6 3.6L Turbo	VO-88		VCA-1184	NS ⁴³⁷
2017				
ATS				
4 cyl. 2.0L Turbo	VO-200	VA-457	VCA-1184	
4 cyl. 2.5L	VO-88	VA-457	VCA-1184	
V6 3.6L Non turbo	VO-201	VA-457	VCA-1184	
V6 3.6L Turbo	VO-201	VA-471 ¹¹²	VCA-1184	
CT6				
4 cyl. 2.0L Turbo	VO-200		VCA-1184	NS ⁴³⁷
V6 3.0L Turbo	VO-201		VCA-1184	NS ⁴³⁷
V6 3.6L	VO-201		VCA-1184	NS ⁴³⁷
CTS				
4 cyl. 2.0L Turbo	VO-200	VA-457	VCA-1184	NS ⁴³⁷
V6 3.6L (S)	VO-201	VA-457	VCA-1184	NS ⁴³⁷
V6 3.6L (8) Turbo	VO-201		VCA-1184	NS ⁴³⁷
V8 6.2L (6) (S.C.)	VO-200		VCA-1184	NS ⁴³⁷
Escalade, Escalade ESV				
V8 6.2L	VO-88	VA-324	VCA-1173	NS ⁴³⁷
XT5				
V6 3.6	VO-201	VA-467	VCA-1184	NS ⁴³⁷
XTS				
V6 3.6L Non turbo	VO-88	VA-308	VCA-1184	NS ⁴³⁷
V6 3.6L Turbo	VO-88		VCA-1184	NS ⁴³⁷
2016				
ATS				
4 cyl. 2.0L Turbo	VO-200	VA-457	VCA-1184	
4 cyl. 2.5L	VO-200	VA-457	VCA-1184	
V6 3.6L Non turbo	VO-201	VA-457	VCA-1184	
V6 3.6L Turbo	VO-201	VA-471 ¹¹²	VCA-1184	
CT6				
4 cyl. 2.0L Turbo	VO-200		VCA-1184	NS ⁴³⁷
V6 3.0L Turbo	VO-201		VCA-1184	NS ⁴³⁷
V6 3.6L	VO-201		VCA-1184	NS ⁴³⁷
CTS				
4 cyl. 2.0L Turbo	VO-200	VA-457	VCA-1184	NS ⁴³⁷
V6 3.6L (S)	VO-201	VA-457	VCA-1184	NS ⁴³⁷

Se reporter à table de matière pour les notes en bas de page en français. Utilize el contenido para ver notas a pie.

NS - Non-Serviceable / Non réparable / No reparable LF - Life-Time Filter / Filtro para toda la vida / Filtre à vie

¹¹² Requires two (2). ⁴³⁷ Requires replacement of the complete fuel pump/fuel filter module.



CADILLAC (cont'd)

2016

CTS

V6 3.6L (8) Turbo	VO-201		VCA-1184	NS ⁴³⁷
V8 6.2L (6) (S.C.)	VO-200		VCA-1184	NS ⁴³⁷

ELR

4 cyl. 1.4L FI (Electric/gas)	VO-122	VA-327	VCA-1078C ^{X401} VCA-1078 ^{Z401}	NS ⁴³⁷
-------------------------------	--------	--------	---	-------------------

Escalade, Escalade ESV

V8 6.2L	VO-88	VA-259	VCA-1173	NS ⁴³⁷
---------	-------	--------	----------	-------------------

SRX

V6 3.6L	VO-88	VA-296	VCA-1078C ^{X961} VCA-1078 ^{Z961}	
---------	-------	--------	---	--

XTS

V6 3.6L Non turbo	VO-88	VA-308	VCA-1184	NS ⁴³⁷
V6 3.6L Turbo	VO-88		VCA-1184	NS ⁴³⁷

2015

ATS

4 cyl. 2.0L Turbo	VO-200	VA-457	VCA-1184	
4 cyl. 2.5L	VO-200	VA-457	VCA-1184	
V6 3.6L	VO-67	VA-457	VCA-1184	

CTS

4 cyl. 2.0L (X) Turbo	VO-200	VA-457	VCA-1184	NS ⁴³⁷
V6 3.6L (3) (Flex Fuel)	VO-67	VA-457	VCA-1184	NS ⁴³⁷
V6 3.6L (8) Turbo	VO-88		VCA-1184	NS ⁴³⁷
V8 6.2L (P) (S.C.)	VO-88		VCA-1043	NS ⁴³⁷

ELR

4 cyl. 1.4L FI (Electric/gas)	VO-122	VA-327	VCA-1078C ^{X401} VCA-1078 ^{Z401}	NS ⁴³⁷
-------------------------------	--------	--------	---	-------------------

Escalade, Escalade ESV

V8 6.2L	VO-88	VA-259	VCA-1173	NS ⁴³⁷
---------	-------	--------	----------	-------------------

SRX

V6 3.6L	VO-88	VA-296	VCA-1078C ^{X401} VCA-1078 ^{Z401}	
---------	-------	--------	---	--

XTS

V6 3.6L Non turbo	VO-88	VA-308	VCA-1184	NS ⁴³⁷
V6 3.6L Turbo	VO-88		VCA-1184	NS ⁴³⁷

2014

ATS

4 cyl. 2.0L Turbo	VO-200	VA-457	VCA-1184	
4 cyl. 2.5L	VO-200	VA-457	VCA-1184	
V6 3.6L	VO-67	VA-457	VCA-1184	

CTS

4 cyl. 2.0L (X) Turbo	VO-200	VA-457	VCA-1184	NS ⁴³⁷
V6 3.0L (5)	VO-67	VA-263	VCA-1043	NS ⁴³⁷
V6 3.6L (3) Non turbo	VO-67	VA-263	VCA-1043	NS ⁴³⁷
V6 3.6L Turbo	VO-88		VCA-1184	NS ⁴³⁷
V8 6.2L (P) (S.C.)	VO-88		VCA-1043	NS ⁴³⁷

ELR

4 cyl. 1.4L FI (Electric/gas)	VO-122	VA-327	VCA-1078C ^{X401} VCA-1078 ^{Z401}	NS ⁴³⁷
-------------------------------	--------	--------	---	-------------------

Escalade, Escalade ESV

V8 6.2L	VO-88	VA-259	VCA-1173	NS ⁴³⁷
---------	-------	--------	----------	-------------------

Se reporter à table de matière pour les notes en bas de page en français. Utilize el contenido para ver notas a pie.

NS - Non-Serviceable / Non réparable / No reparable LF - Life-Time Filter / Filtro para toda la vida / Filtre à vie

⁴³⁷ Requires replacement of the complete fuel pump/fuel filter module. ^{X401}Dust and Odor filter ^{X961}Dust and odor filter ^{Z401}Dust filter ^{Z961}Dust filter



CADILLAC (cont'd)

	Oil	Air	Cabin*	Fuel
2014				
SRX				
V6 3.6L	VO-88	VA-296	VCA-1078C ^{X401} VCA-1078 ^{Z401}	
XTS				
V6 3.6L Non turbo	VO-88	VA-308	VCA-1184	NS ⁴³⁷
V6 3.6L Turbo	VO-88		VCA-1184	NS ⁴³⁷
2013				
ATS				
4 cyl. 2.0L Turbo	VO-200	VA-457	VCA-1184	
4 cyl. 2.5L	VO-200	VA-457	VCA-1184	
V6 3.6L	VO-67	VA-457	VCA-1184	
CTS				
V6 3.0L (5)	VO-67	VA-263	VCA-1043	NS ⁴³⁷
V6 3.6L (3) (Flex Fuel)	VO-67	VA-263	VCA-1043	NS ⁴³⁷
V8 6.2L (P) (S.C.)	VO-88		VCA-1043	NS ⁴³⁷
Escalade, Escalade ESV/EXT				
V8 6.0L (J) Hybrid	VO-88	VA-259		NS ⁴³⁷
V8 6.2L (F)	VO-88	VA-259		NS ⁴³⁷
SRX				
V6 3.6L	VO-88	VA-296	VCA-1078C ^{X401} VCA-1078 ^{Z401}	
XTS				
V6 3.6L	VO-88	VA-308	VCA-1184	NS ⁴³⁷
2012				
CTS				
V6 3.0L (5)	VO-67	VA-263	VCA-1043	NS ⁴³⁷
V6 3.6L (3)	VO-67	VA-263	VCA-1043	NS ⁴³⁷
V8 6.2L (P) (S.C.)	VO-88		VCA-1043	NS ⁴³⁷
Escalade, Escalade ESV/EXT				
V8 6.0L (J) Hybrid	VO-88	VA-259		NS ⁴³⁷
V8 6.2L (F)	VO-88	VA-259		NS ⁴³⁷
SRX				
V6 3.6L	VO-88	VA-296	VCA-1078C ^{X401} VCA-1078 ^{Z401}	
2011				
CTS				
V6 3.0L (Y)	VO-67	VA-263	VCA-1043	NS ⁴³⁷
V6 3.6L (D)	VO-67	VA-263	VCA-1043	NS ⁴³⁷
V8 6.2L (P) (S.C.)	VO-88		VCA-1043	NS ⁴³⁷
DTS				
V8 4.6L (6,S) FI	VO-108	VA-176	VCA-1022 ^{X019} VCA-1165 ^{Z019}	NS ⁴³⁷
Escalade, Escalade ESV/EXT				
V8 6.0L (J) Hybrid	VO-88	VA-259		NS ⁴³⁷
V8 6.2L (F)	VO-88	VA-259		NS ⁴³⁷
SRX				
V6 2.8L Turbo	VO-67	VA-296	VCA-1078C ^{X401} VCA-1078 ^{Z401}	
V6 3.0L	VO-88	VA-296	VCA-1078C ^{X401} VCA-1078 ^{Z401}	
STS				
V6 3.6L (D)	VO-67	VA-336	VCA-1043	

Se reporter à table de matière pour les notes en bas de page en français. Utilize el contenido para ver notas a pie.

NS - Non-Serviceable / Non réparable / No reparable LF - Life-Time Filter / Filtro para toda la vida / Filtre à vie

⁴³⁷ Requires replacement of the complete fuel pump/fuel filter module. ^{X019}Dust filter. ^{X401}Dust and Odor filter ^{Z019}Dust and odor filter. ^{Z401}Dust filter



CADILLAC (cont'd)

2010

CTS

V6 3.0L (G)	VO-67	VA-263	VCA-1043	NS ⁴³⁷
V6 3.6L (V)	VO-67	VA-263	VCA-1043	NS ⁴³⁷
V8 6.2L (P) (S.C.)	VO-88		VCA-1043	NS ⁴³⁷

DTS

V8 4.6L (Y,9) FI	VO-108	VA-176	VCA-1022 ^{X019} VCA-1165 ^{Z019}	NS ⁴³⁷
------------------	--------	--------	--	-------------------

Escalade, Escalade ESV/EXT

V8 6.0L (J) Hybrid	VO-88	VA-259		NS ⁴³⁷
V8 6.2L (F)	VO-88	VA-259		NS ⁴³⁷

SRX

V6 2.8L Turbo	VO-67	VA-296	VCA-1078C ^{X401} VCA-1078 ^{Z401}	
V6 3.0L	VO-88	VA-296	VCA-1078C ^{X401} VCA-1078 ^{Z401}	

STS

V6 3.6L (V)	VO-67	VA-336	VCA-1043	
V8 4.6L (A)	VO-108	VA-336	VCA-1043	

2009

CTS

V6 3.6L (V) DI	VO-67	VA-263	VCA-1043	NS ⁴³⁷
V6 3.6L (7) FI	VO-67	VA-263	VCA-1043	NS ⁴³⁷
V8 6.2L (P) FI (S.C.)	VO-88		VCA-1043	NS ⁴³⁷

DTS

V8 4.6L (Y,9) FI	VO-108	VA-176	VCA-1022 ^{X019} VCA-1165 ^{Z019}	NS ⁴³⁷
------------------	--------	--------	--	-------------------

Escalade, Escalade ESV/EXT

V8 6.0L (5) Hybrid	VO-88	VA-259		NS ⁴³⁷
V8 6.2L (2)	VO-88	VA-259		NS ⁴³⁷

SRX

V6 3.6L	VO-67	VA-336	VCA-1043	
V8 4.6L	VO-108	VA-336	VCA-1043	

STS

V6 3.6L (V) FI	VO-67	VA-336	VCA-1043	
V8 4.4L (D) FI (S.C.)	VO-88		VCA-1043	NS ⁴³⁷
V8 4.6L (A) FI	VO-108	VA-336	VCA-1043	

XLR

V8 4.4L (D) FI (S.C.)	VO-88			NS ⁴³⁷
V8 4.6L (A) FI	VO-108	VA-109 ¹¹²		NS ⁴³⁷

2008

CTS

V6 3.6L (V) DI	VO-67	VA-263	VCA-1043	NS ⁴³⁷
V6 3.6L (7) FI	VO-67	VA-263	VCA-1043	NS ⁴³⁷

DTS

V8 4.6L (Y,9) FI	VO-108	VA-176	VCA-1022 ^{X019} VCA-1165 ^{Z019}	NS ⁴³⁷
------------------	--------	--------	--	-------------------

Escalade, Escalade ESV/EXT

V8 6.2L (8) FI	VO-88	VA-259		NS ⁴³⁷
----------------	-------	--------	--	-------------------

SRX

V6 3.6L (7) FI	VO-67	VA-336	VCA-1043	
V8 4.6L (A) FI	VO-108	VA-336	VCA-1043	

Se reporter à table de matière pour les notes en bas de page en français. Utilize el contenido para ver notas a pie.

NS - Non-Serviceable / Non réparable / No reparable LF - Life-Time Filter / Filtro para toda la vida / Filtre à vie

¹¹² Requires two (2). ⁴³⁷ Requires replacement of the complete fuel pump/fuel filter module. ^{X019}Dust filter. ^{X401}Dust and Odor filter ^{Z019}Dust and odor filter. ^{Z401}Dust filter



CADILLAC (cont'd)

	Oil	Air	Cabin*	Fuel
2008				
STS				
V6 3.6L (V) FI	VO-67	VA-336	VCA-1043	
V8 4.4L (D) FI (S.C.)	VO-88		VCA-1043	NS ⁴³⁷
V8 4.6L (A) FI	VO-108	VA-336	VCA-1043	
XLR				
V8 4.4L (D) FI (S.C.)	VO-88			NS ⁴³⁷
V8 4.6L (A) FI	VO-108	VA-109 ¹¹²		NS ⁴³⁷
2007				
CTS				
V6 2.8L (T) FI	VO-67	VA-335	VCA-1043	
V6 3.6L (7) FI	VO-67	VA-335	VCA-1043	
V8 6.0L (U) FI	VO-88		VCA-1043	
DTS				
V8 4.6L (Y,9) FI	VO-108	VA-176	VCA-1022 ^{X019} VCA-1165 ^{Z019}	NS ⁴³⁷
Escalade, Escalade ESV/EXT				
V8 6.2L (8) FI	VO-88	VA-259		NS ⁴³⁷
SRX				
V6 3.6L (7) FI	VO-67	VA-336	VCA-1043	
V8 4.6L (A) FI	VO-108	VA-336	VCA-1043	
STS				
V6 3.6L (7) FI	VO-67	VA-336	VCA-1043	
V8 4.4L (D) FI (S.C.)	VO-88		VCA-1043	NS ⁴³⁷
V8 4.6L (A) FI	VO-108	VA-336	VCA-1043	
XLR				
V8 4.4L (D) FI (S.C.)	VO-88			NS ⁴³⁷
V8 4.6L (A) FI	VO-108	VA-109 ¹¹²		NS ⁴³⁷
2006				
CTS				
V6 2.8L (T) FI	VO-67	VA-335	VCA-1043	
V6 3.6L (7) FI	VO-67	VA-335	VCA-1043	
V8 6.0L (U) FI	VO-58		VCA-1043	
DTS				
V8 4.6L (Y,9) FI	VO-108	VA-176	VCA-1022 ^{X019} VCA-1165 ^{Z019}	NS ⁴³⁷
Escalade, Escalade ESV/EXT				
V8 6.0L (N) FI	VO-58	VA-259		NS ⁴³⁷
SRX				
V6 3.6L (7) FI	VO-67	VA-336	VCA-1043	
V8 4.6L (A) FI	VO-108	VA-336	VCA-1043	
STS				
V6 3.6L (7) FI	VO-67	VA-336	VCA-1043	
V8 4.4L (D) FI (S.C.)	VO-88		VCA-1043	NS ⁴³⁷
V8 4.6L (A) FI	VO-108	VA-336	VCA-1043	
XLR				
V8 4.4L (D) FI (S.C.)	VO-88			NS ⁴³⁷
V8 4.6L (A) FI	VO-108	VA-109 ¹¹²		NS ⁴³⁷
2005				
CTS				
V6 2.8L (T) FI	VO-67	VA-335	VCA-1043	
V6 3.6L (7) FI	VO-67	VA-335	VCA-1043	
V8 5.7L (S) FI	VO-58		VCA-1043	

Se reporter à table de matière pour les notes en bas de page en français. Utilize el contenido para ver notas a pie.

NS - Non-Serviceable / Non réparable / No repairable LF - Life-Time Filter / Filtro para toda la vida / Filtre à vie

¹¹² Requires two (2). ⁴³⁷ Requires replacement of the complete fuel pump/fuel filter module. ^{X019}Dust filter. ^{Z019}Dust and odor filter.



CADILLAC (cont'd)

2005

DeVille

V8 4.6L (Y,9) FI	VO-108	VA-109	VCA-1022 ^{X019} VCA-1165 ^{Z019}	VG-33
------------------	--------	--------	--	-------

Escalade, Escalade ESV/EXT

V8 5.3L (T) FI	VO-58	VA-259		NS ⁴³⁷
V8 6.0L (N) FI	VO-58	VA-259		NS ⁴³⁷

SRX

V6 3.6L (7) FI	VO-67	VA-336	VCA-1043	
V8 4.6L (A) FI	VO-108	VA-336	VCA-1043	

STS

V6 3.6L (7) FI	VO-67	VA-336	VCA-1043	
V8 4.6L (A) FI	VO-108	VA-336	VCA-1043	

XLR

V8 4.6L (A) FI	VO-108	VA-109 ¹¹²		NS ⁴³⁷
----------------	--------	-----------------------	--	-------------------

2004

CTS

V6 3.2L (N) FI	VO-78	VA-335	VCA-1043	VG-33
V6 3.6L (7) FI	VO-67	VA-335	VCA-1043	
V8 5.7L (S) FI	VO-58		VCA-1043	

DeVille

V8 4.6L (Y,9) FI	VO-108	VA-109	VCA-1022 ^{X019} VCA-1165 ^{Z019}	VG-33
------------------	--------	--------	--	-------

Escalade, Escalade ESV/EXT

V8 5.3L (T) FI	VO-58	VA-259	VCA-1074 ^{X628} VCA-1169 ^{Z628}	NS ⁴³⁷
V8 6.0L (N) FI	VO-58	VA-259	VCA-1074 ^{X628} VCA-1169 ^{Z628}	NS ⁴³⁷

Seville

V8 4.6L (9,Y) FI	VO-108	VA-109		VG-33
------------------	--------	--------	--	-------

SRX

V6 3.6L (7) FI	VO-67	VA-336	VCA-1043	
V8 4.6L (A) FI	VO-108	VA-336	VCA-1043	

XLR

V8 4.6L (A) FI	VO-108	VA-109 ¹¹²		NS ⁴³⁷
----------------	--------	-----------------------	--	-------------------

2003

CTS

V6 3.2L (N) FI	VO-78	VA-335	VCA-1043	VG-33
----------------	-------	--------	----------	-------

DeVille

V8 4.6L (Y,9) FI	VO-108	VA-109	VCA-1022 ^{X019} VCA-1165 ^{Z019}	VG-33
------------------	--------	--------	--	-------

Escalade, Escalade ESV/EXT

V8 5.3L (T) FI	VO-58	VA-259	VCA-1074 ^{X628} VCA-1169 ^{Z628}	VG-14
V8 6.0L (N) FI	VO-58	VA-259	VCA-1074 ^{X628} VCA-1169 ^{Z628}	VG-14

Seville

V8 4.6L (9,Y) FI	VO-108	VA-109		VG-33
------------------	--------	--------	--	-------

2002

DeVille

V8 4.6L (Y,9) FI	VO-108	VA-109	VCA-1022 ^{X019} VCA-1165 ^{Z019}	VG-33
------------------	--------	--------	--	-------

Se reporter à table de matière pour les notes en bas de page en français. Utilize el contenido para ver notas a pie.

NS - Non-Serviceable / Non réparable / No reparable LF - Life-Time Filter / Filtro para toda la vida / Filtre à vie

¹¹² Requires two (2). ⁴³⁷ Requires replacement of the complete fuel pump/fuel filter module. ^{X019} Dust filter. ^{X628} Dust and odor. ^{Z019} Dust and odor filter.

^{Z628} Dust filter.



CADILLAC (cont'd)

	Oil	Air	Cabin*	Fuel
2002				
Eldorado				
V8 4.6L (9,Y) FI	VO-108	VA-78		
Escalade, Escalade ESV/EXT				
V8 5.3L (T) FI	VO-108	VA-259	VCA-1003	VG-14
V8 6.0L (N) FI	VO-108	VA-259	VCA-1003	VG-14
Seville				
V8 4.6L (9,Y) FI	VO-108	VA-109		VG-33
2001				
Catera				
V6 3.0L (R) FI	VO-73		VCA-1150 ²¹¹	
DeVille				
V8 4.6L (Y,9) FI	VO-108	VA-109	VCA-1022 ^{X019} VCA-1165 ^{Z019}	VG-33
Eldorado				
V8 4.6L (9,Y) FI	VO-108	VA-78		
Seville				
V8 4.6L (9,Y) FI	VO-108	VA-109		VG-33
2000				
Catera				
V6 3.0L (R) FI	VO-73		VCA-1150 ²¹¹	
DeVille				
V8 4.6L (Y,9) FI	VO-108	VA-109	VCA-1022 ^{X019} VCA-1165 ^{Z019}	VG-33
Eldorado				
V8 4.6L (9,Y) FI	VO-108	VA-78		
Escalade				
V8 5.7L (R) FI	VO-55	VA-92		VG-14
Seville				
V8 4.6L (9,Y) FI	VO-108	VA-109		VG-33
1999				
Catera				
V6 3.0L (R) FI	VO-73		VCA-1150 ²¹¹	
Deville Concours				
V8 4.6L (9) FI	VO-108	VA-78		
DeVille				
V8 4.6L (Y) FI	VO-108	VA-78		
Eldorado				
V8 4.6L (9,Y) FI	VO-108	VA-78		
Escalade				
V8 5.7L (R) FI	VO-55	VA-92		VG-14
Seville				
V8 4.6L (9,Y) FI	VO-108	VA-109		VG-33
1998				
Catera				
V6 3.0L (R) FI	VO-16 ^{X466} VO-73 ^{Z466}		VCA-1150 ²¹¹	
Deville Concours				
V8 4.6L (9) FI	VO-108	VA-78		
DeVille				
V8 4.6L (Y) FI	VO-108	VA-78		
Eldorado				
V8 4.6L (9,Y) FI	VO-108	VA-78		

Se reporter à table de matière pour les notes en bas de page en français. Utilize el contenido para ver notas a pie.

NS - Non-Serviceable / Non réparable / No reparable LF - Life-Time Filter / Filtro para toda la vida / Filtre à vie

²¹¹ Dust filter. ^{X019}Dust filter. ^{X466}Spin-on filter. ^{Z019}Dust and odor filter. ^{Z466}Cartridge filter.



CADILLAC (cont'd)

Year	Model	Oil	Air	Cabin*	Fuel
1998					
Seville					
V8 4.6L (9,Y) FI	VO-108	VA-109			VG-33
1997					
Catera					
V6 3.0L (R) FI	VO-16 ^{X466} VO-73 ^{Z466}			VCA-1150 ²¹¹	
Deville Concours					
V8 4.6L (9,Y) FI	VO-108	VA-78			
DeVille					
V8 4.6L (9,Y) FI	VO-108	VA-78			
Eldorado					
V8 4.6L (9,Y) FI	VO-108	VA-78			
Seville					
V8 4.6L (9,Y) FI	VO-108	VA-78			
1996					
Deville Concours					
V8 4.6L (9) FI	VO-108	VA-78			VG-30
DeVille					
V8 4.6L (Y) FI	VO-108	VA-78			VG-30
Eldorado					
V8 4.6L (9,Y) FI	VO-108	VA-78			VG-30
Fleetwood Brougham					
V8 5.7L (P) FI	VO-55	VA-78			
Seville					
V8 4.6L (9,Y) FI	VO-108	VA-78			VG-30
1995					
Deville Concours					
V8 4.6L (Y) FI	VO-108	VA-78			VG-30
DeVille					
V8 4.9L (B) FI	VO-108	VA-78			VG-30
Eldorado					
V8 4.6L (9,Y) FI	VO-108	VA-78			VG-30
Fleetwood Brougham					
V8 5.7L (P) FI	VO-55	VA-78			
Seville					
V8 4.6L (9,Y) FI	VO-108	VA-78			VG-30

CHEVROLET

Year	Model	Oil	Air	Cabin*	Fuel
2019					
Blazer					
4 cyl. 2.5L	VO-88	VA-467		VCA-1184	NS
V6 3.6L	VO-201	VA-467		VCA-1184	
Bolt EV					
-- Electric				VCA-1184	
Camaro					
4 cyl. 2.0L Turbo	VO-200	VA-457		VCA-1184	NS ⁴³⁷
V6 3.6L	VO-201	VA-457		VCA-1184	NS ⁴³⁷
V8 6.2L	VO-200			VCA-1184	NS ⁴³⁷
V8 6.2L Supercharged	VO-200			VCA-1184	NS ⁴³⁷
Colorado					
4 cyl. 2.5L	VO-200	VA-425		VCA-1184	NS ⁴³⁷
4 cyl. 2.8L Diesel Turbo	VO-172	VA-425		VCA-1184	

Se reporter à table de matière pour les notes en bas de page en français. Utilize el contenido para ver notas a pie.

NS - Non-Serviceable / Non réparable / No reparable LF - Life-Time Filter / Filtro para toda la vida / Filtre à vie

²¹¹ Dust filter. ⁴³⁷ Requires replacement of the complete fuel pump/fuel filter module. ^{X466} Spin-on filter. ^{Z466} Cartridge filter.



CHEVROLET (cont'd)

	Oil	Air	Cabin*	Fuel
2019				
Colorado				
V6 3.6L	VO-98	VA-425	VCA-1184	NS ⁴³⁷
Corvette				
V8 6.2L (7)	VO-200			NS ⁴³⁷
V8 6.2L (6) (S.C.)	VO-200			NS ⁴³⁷
Cruze				
4 cyl. 1.4L Turbo	VO-200	VA-471	VCA-1184	NS ⁴³⁷
4 cyl. 1.6L Diesel Turbo	VO-98	VA-471	VCA-1184	
Equinox				
4 cyl. 1.5L Turbo	VO-160	VA-474	VCA-1184	NS ⁴³⁷
4 cyl. 1.6L Diesel Turbo	VO-98	VA-474	VCA-1184	
4 cyl. 2.0L Turbo	VO-160	VA-474	VCA-1184	NS ⁴³⁷
Express Van				
4 cyl. 2.8L Diesel Turbo		VA-485		
V6 4.3L	VO-88			NS ⁴³⁷
V8 6.0L	VO-88	VA-485		NS ⁴³⁷
Impala				
4 cyl. 2.5L	VO-200	VA-308	VCA-1184	NS ⁴³⁷
V6 3.6L	VO-88	VA-308	VCA-1184	NS ⁴³⁷
Malibu				
4 cyl. 1.5L Turbo	VO-200	VA-459	VCA-1184	NS ⁴³⁷
4 cyl. 1.8L Hybrid	VO-98	VA-459	VCA-1184	NS ⁴³⁷
4 cyl. 2.0L Turbo	VO-200		VCA-1184	NS ⁴³⁷
Silverado 1500				
4 cyl. 2.7L Turbo	VO-202	VA-505 ⁹³¹	VCA-1184 ^{X788} VCA-1183 ^{Z788}	NS ⁴³⁷
V6 4.3L	VO-88	VA-505 ⁹³¹	VCA-1184 ^{X788} VCA-1183 ^{Z788}	NS ⁴³⁷
V8 5.3L	VO-88	VA-505 ⁹³¹	VCA-1184 ^{X788} VCA-1183 ^{Z788}	NS ⁴³⁷
V8 6.2L	VO-88	VA-505 ⁹³¹	VCA-1184 ^{X788} VCA-1183 ^{Z788}	NS ⁴³⁷
Silverado 1500 LD				
V8 5.3	VO-88	VA-324	VCA-1173	NS ⁴³⁷
Siverado 2500HD, 3500HD				
V8 6.0L	VO-88	VA-324	VCA-1173	NS ⁴³⁷
V8 6.6L Diesel Turbo	VO-75	VA-469	VCA-1173	
Sonic				
4 cyl. 1.4 Turbo	VO-98 ^{X907} VO-173 ^{Z907}	VA-426	VCA-1078C ^{X401} VCA-1078 ^{Z401}	NS ⁴³⁷
Spark				
4 cyl. 1.4L	VO-160		VCA-1078C ^{X401} VCA-1078 ^{Z401}	NS ⁴³⁷
Suburban, Tahoe				
V8 5.3L	VO-88	VA-324	VCA-1173	NS ⁴³⁷
V8 6.2L	VO-88	VA-324	VCA-1173	NS ⁴³⁷
Suburban 3500 HD				
V8 6.0L (Flex Fuel)	VO-88	VA-324		NS ⁴³⁷
Traverse				
4 cyl. 2.0L	VO-200	VA-467	VCA-1184	NS ⁴³⁷
V6 3.6L	VO-88	VA-467	VCA-1184	NS ⁴³⁷

Se reporter à table de matière pour les notes en bas de page en français. Utilize el contenido para ver notas a pie.

NS - Non-Serviceable / Non réparable / No repairable LF - Life-Time Filter / Filtro para toda la vida / Filtre à vie

⁴³⁷ Requires replacement of the complete fuel pump/fuel filter module. ⁹³¹ Standard service ^{X401}Dust and Odor filter ^{X788}Dust ^{X907}With oil filter housing marked Hengst. ^{Z401}Dust filter ^{Z788}Dust and Odor ^{Z907}With oil filter housing marked UFI



CHEVROLET (cont'd)

2019

Trax

4 cyl. 1.4 Turbo	VO-98 ^{X907} VO-173 ^{Z907}	VA-424	VCA-1078C ^{X401} VCA-1078 ^{Z401}	NS ⁴³⁷
------------------	---	--------	---	-------------------

Volt

4 cyl 1.5L FI (Electric/gas)	VO-200		VCA-1184	NS ⁴³⁷
------------------------------	--------	--	----------	-------------------

2018

Bolt EV

-- Electric			VCA-1184	
-------------	--	--	----------	--

Camaro

4 cyl. 2.0L Turbo	VO-200	VA-457	VCA-1184	NS ⁴³⁷
V6 3.6L	VO-201	VA-457	VCA-1184	NS ⁴³⁷
V8 6.2L	VO-200		VCA-1184	NS ⁴³⁷
V8 6.2L Supercharged	VO-200		VCA-1184	NS ⁴³⁷

City Express

4 cyl. 2.0	VO-106	VA-244	VCA-2043	NS ⁴³⁷
------------	--------	--------	----------	-------------------

Colorado

4 cyl. 2.5L	VO-200	VA-425	VCA-1184	NS ⁴³⁷
4 cyl. 2.8L Diesel Turbo	VO-172	VA-425	VCA-1184	
V6 3.6L	VO-98	VA-425	VCA-1184	NS ⁴³⁷

Corvette

V8 6.2L (7)	VO-200			NS ⁴³⁷
V8 6.2L (6) (S.C.)	VO-200			NS ⁴³⁷

Cruze

4 cyl. 1.4L Turbo	VO-200	VA-471	VCA-1184	NS ⁴³⁷
4 cyl. 1.6L Diesel Turbo	VO-98	VA-471	VCA-1184	

Equinox

4 cyl 1.5L Turbo	VO-160	VA-474	VCA-1184	NS ⁴³⁷
4 cyl 1.6L Diesel Turbo	VO-98	VA-474	VCA-1184	
4 cyl 2.0L Turbo	VO-160	VA-474	VCA-1184	NS ⁴³⁷

Express Van

4 cyl. 2.8L Diesel Turbo		VA-485		
V6 4.3L	VO-88			NS ⁴³⁷
V8 6.0L	VO-88	VA-485		NS ⁴³⁷

Impala

4 cyl. 2.5L	VO-200	VA-308	VCA-1184	NS ⁴³⁷
V6 3.6L	VO-88	VA-308	VCA-1184	NS ⁴³⁷

Malibu

4 cyl. 1.5L Turbo	VO-200	VA-459	VCA-1184	NS ⁴³⁷
4 cyl. 1.8L Hybrid	VO-98	VA-459	VCA-1184	NS ⁴³⁷
4 cyl. 2.0L Turbo	VO-200		VCA-1184	NS ⁴³⁷

Silverado Pickup

V6 4.3L	VO-88	VA-324	VCA-1173	NS ⁴³⁷
V8 5.3L Hybrid	VO-88	VA-324	VCA-1173	NS ⁴³⁷
V8 5.3L Non Hybrid	VO-88	VA-324	VCA-1173	NS ⁴³⁷
V8 6.0L	VO-88	VA-324	VCA-1173	NS ⁴³⁷
V8 6.2L	VO-88	VA-324	VCA-1173	NS ⁴³⁷
V8 6.6L Diesel Turbo	VO-75	VA-469	VCA-1173	

Sonic

4 cyl. 1.4 Turbo	VO-98 ^{X907} VO-173 ^{Z907}	VA-426	VCA-1078C ^{X401} VCA-1078 ^{Z401}	NS ⁴³⁷
------------------	---	--------	---	-------------------

Se reporter à table de matière pour les notes en bas de page en français. Utilize el contenido para ver notas a pie.

NS - Non-Serviceable / Non réparable / No reparable LF - Life-Time Filter / Filtro para toda la vida / Filtre à vie

⁴³⁷ Requires replacement of the complete fuel pump/fuel filter module. ^{X401}Dust and Odor filter ^{X907}With oil filter housing marked Hengst. ^{Z401}Dust filter

^{Z907}With oil filter housing marked UFI



CHEVROLET (cont'd)

	Oil	Air	Cabin*	Fuel
2018				
Sonic				
4 cyl. 1.8L	VO-98 ^{X907} VO-173 ^{Z907}	VA-426	VCA-1078C ^{X401} VCA-1078 ^{Z401}	NS ⁴³⁷
Spark				
4 cyl. 1.4L	VO-160		VCA-1078C ^{X401} VCA-1078 ^{Z401}	NS ⁴³⁷
Suburban, Tahoe				
V8 5.3L	VO-88	VA-324	VCA-1173	NS ⁴³⁷
V8 6.2L	VO-88	VA-324	VCA-1173	NS ⁴³⁷
Suburban 3500 HD				
V8 6.0L (Flex Fuel)	VO-88	VA-324		NS ⁴³⁷
Traverse				
4 cyl. 2.0L	VO-200	VA-467	VCA-1184	NS ⁴³⁷
V6 3.6L	VO-88	VA-467	VCA-1184	NS ⁴³⁷
Trax				
4 cyl. 1.4 Turbo	VO-98 ^{X907} VO-173 ^{Z907}	VA-424	VCA-1078C ^{X401} VCA-1078 ^{Z401}	NS ⁴³⁷
Volt				
4 cyl 1.5L FI (Electric/gas)	VO-200		VCA-1078C ^{X401} VCA-1078 ^{Z401}	NS ⁴³⁷
2017				
Bolt EV				
-- Electric			VCA-1184	
Camaro				
4 cyl. 2.0L Turbo	VO-200	VA-457	VCA-1184	NS ⁴³⁷
V6 3.6L	VO-201	VA-457	VCA-1184	NS ⁴³⁷
V8 6.2L	VO-200		VCA-1184	NS ⁴³⁷
V8 6.2L Supercharged	VO-200		VCA-1184	NS ⁴³⁷
Caprice				
V6 3.6L (Flex Fuel)	VO-67	VA-375		NS ⁴³⁷
V8 6.0L (Flex Fuel)	VO-88	VA-375		NS ⁴³⁷
City Express				
4 cyl. 2.0	VO-106	VA-244		NS ⁴³⁷
Colorado				
4 cyl. 2.5L	VO-200	VA-425	VCA-1184	NS ⁴³⁷
4 cyl. 2.8L Diesel Turbo	VO-172	VA-425	VCA-1184	
V6 3.6L	VO-98	VA-425	VCA-1184	NS ⁴³⁷
Corvette				
V8 6.2L (7)	VO-200			NS ⁴³⁷
V8 6.2L (6) (S.C.)	VO-200			NS ⁴³⁷
Cruze				
4 cyl. 1.4L Turbo	VO-160	VA-471	VCA-1184	NS ⁴³⁷
4 cyl. 1.6L Diesel Turbo	VO-98	VA-471	VCA-1184	
Equinox				
4 cyl 2.4L	VO-76	VA-255	VCA-1075	NS ⁴³⁷
V6 3.6L	VO-88	VA-255	VCA-1075	NS ⁴³⁷
Express Van				
4 cyl. 2.8L Diesel Turbo		VA-485		
V8 4.8L (Flex Fuel)	VO-88	VA-485		NS ⁴³⁷
V8 6.0L (Flex Fuel)	VO-88	VA-485		NS ⁴³⁷

Se reporter à table de matière pour les notes en bas de page en français. Utilize el contenido para ver notas a pie.

NS - Non-Serviceable / Non réparable / No reparable LF - Life-Time Filter / Filtro para toda la vida / Filtre à vie

⁴³⁷ Requires replacement of the complete fuel pump/fuel filter module. ^{X401}Dust and Odor filter ^{X907}With oil filter housing marked Hengst. ^{Z401}Dust filter

^{Z907}With oil filter housing marked UFI



CHEVROLET (cont'd)

2017

Impala

4 cyl. 2.5L	VO-200	VA-308	VCA-1184	NS ⁴³⁷
V6 3.6L	VO-88	VA-308	VCA-1184	NS ⁴³⁷

Malibu

4 cyl. 1.5L Turbo	VO-160	VA-459	VCA-1184	NS ⁴³⁷
4 cyl. 1.8L Hybrid	VO-98	VA-459	VCA-1184	NS ⁴³⁷
4 cyl. 2.0L Turbo	VO-200		VCA-1184	NS ⁴³⁷

Silverado Pickup

V6 4.3L	VO-88	VA-324	VCA-1173	NS ⁴³⁷
V8 5.3L Hybrid	VO-88	VA-324	VCA-1173	NS ⁴³⁷
V8 5.3L Non Hybrid	VO-88	VA-324	VCA-1173	NS ⁴³⁷
V8 6.0L	VO-88	VA-324	VCA-1173	NS ⁴³⁷
V8 6.2L	VO-88	VA-324	VCA-1173	NS ⁴³⁷
V8 6.6L Diesel Turbo	VO-75	VA-469	VCA-1173	

Sonic

4 cyl. 1.4 Turbo	VO-98 ^{X907} VO-173 ^{Z907}	VA-426	VCA-1078C ^{X401} VCA-1078 ^{Z401}	NS ⁴³⁷
4 cyl. 1.8L	VO-98 ^{X907} VO-173 ^{Z907}	VA-426	VCA-1078C ^{X401} VCA-1078 ^{Z401}	NS ⁴³⁷

Spark

4 cyl. 1.4L	VO-160		VCA-1078C ^{X401} VCA-1078 ^{Z401}	NS ⁴³⁷
-------------	--------	--	---	-------------------

SS

V8 6.2	VO-88	VA-375		NS ⁴³⁷
--------	-------	--------	--	-------------------

Suburban, Tahoe

V8 5.3L (Flex Fuel)	VO-88	VA-324	VCA-1173	NS ⁴³⁷
---------------------	-------	--------	----------	-------------------

Suburban 3500 HD

V8 6.0L (Flex Fuel)	VO-88	VA-324		NS ⁴³⁷
---------------------	-------	--------	--	-------------------

Traverse

V6 3.6L	VO-88	VA-225	VCA-1080	NS ⁴³⁷
---------	-------	--------	----------	-------------------

Trax

4 cyl. 1.4 Turbo	VO-98 ^{X907} VO-173 ^{Z907}	VA-424	VCA-1078C ^{X401} VCA-1078 ^{Z401}	NS ⁴³⁷
------------------	---	--------	---	-------------------

Volt

4 cyl. 1.5L FI (Electric/gas)	VO-160		VCA-1078C ^{X401} VCA-1078 ^{Z401}	NS ⁴³⁷
-------------------------------	--------	--	---	-------------------

2016

Camaro

4 cyl. 2.0L Turbo	VO-200	VA-457	VCA-1184	NS ⁴³⁷
V6 3.6L	VO-201	VA-457	VCA-1184	NS ⁴³⁷
V8 6.2L	VO-200		VCA-1184	NS ⁴³⁷

Caprice

V6 3.6L (Flex Fuel)	VO-67	VA-375		NS ⁴³⁷
V8 6.0L (Flex Fuel)	VO-88	VA-375		NS ⁴³⁷

City Express

4 cyl. 2.0	VO-106	VA-244		NS ⁴³⁷
------------	--------	--------	--	-------------------

Colorado

4 cyl. 2.5L	VO-200	VA-425	VCA-1184	NS ⁴³⁷
4 cyl. 2.8L Diesel Turbo	VO-172	VA-425	VCA-1184	
V6 3.6L	VO-67	VA-425	VCA-1184	NS ⁴³⁷

Se reporter à table de matière pour les notes en bas de page en français. Utilize el contenido para ver notas a pie.

NS - Non-Serviceable / Non réparable / No reparable LF - Life-Time Filter / Filtro para toda la vida / Filtre à vie

⁴³⁷ Requires replacement of the complete fuel pump/fuel filter module. ^{X401}Dust and Odor filter ^{X907}With oil filter housing marked Hengst. ^{Z401}Dust filter

^{Z907}With oil filter housing marked UFI



CHEVROLET (cont'd)

	Oil	Air	Cabin*	Fuel
2016				
Corvette				
V8 6.2L (6) (S.C.)	VO-200			NS ⁴³⁷
V8 6.2L (7) FI	VO-200			NS ⁴³⁷
Cruze				
4 cyl. 1.4L Turbo	VO-160	VA-471	VCA-1184	NS ⁴³⁷
Cruze Limited				
4 cyl. 1.4L (B) FI Turbo	VO-98 ^{X907} VO-173 ^{Z907}	VA-296	VCA-1078C ^{X401} VCA-1078 ^{Z401}	NS ⁴³⁷
4 cyl. 1.8L FI	VO-98 ^{X907} VO-173 ^{Z907}	VA-285	VCA-1078C ^{X401} VCA-1078 ^{Z401}	NS ⁴³⁷
Equinox				
4 cyl. 2.4L	VO-76	VA-255	VCA-1075	NS ⁴³⁷
V6 3.6L	VO-88	VA-255	VCA-1075	NS ⁴³⁷
Express Van				
V8 4.8L (Flex Fuel)	VO-88	VA-169		NS ⁴³⁷
V8 6.0L (B) (CNG)	VO-88	VA-169		
V8 6.0L (G) (Flex Fuel)	VO-88	VA-169		NS ⁴³⁷
V8 6.6L Diesel Turbo	VO-75	VA-381		
Impala				
4 cyl. 2.5L	VO-200	VA-308	VCA-1184	NS ⁴³⁷
V6 3.6L	VO-88	VA-308	VCA-1184	NS ⁴³⁷
Impala Limited				
V6 3.6L (Flex Fuel)	VO-88	VA-299	VCA-1002	NS ⁴³⁷
Malibu				
4 cyl. 1.5L Turbo	VO-160	VA-459	VCA-1184	NS ⁴³⁷
4 cyl. 1.8L Hybrid	VO-98	VA-459	VCA-1184	NS ⁴³⁷
4 cyl. 2.0L Turbo	VO-200		VCA-1184	NS ⁴³⁷
Malibu Limited				
4 cyl. 2.5L FI	VO-200	VA-308	VCA-1078C ^{X401} VCA-1078 ^{Z401}	NS ⁴³⁷
Silverado Pickup				
V6 4.3L	VO-88	VA-259	VCA-1173	NS ⁴³⁷
V8 5.3L Hybrid	VO-88	VA-324	VCA-1173	NS ⁴³⁷
V8 5.3L Non Hybrid	VO-88	VA-259	VCA-1173	NS ⁴³⁷
V8 6.0L	VO-88	VA-259	VCA-1173	NS ⁴³⁷
V8 6.2L	VO-88	VA-259	VCA-1173	NS ⁴³⁷
V8 6.6L Diesel Turbo	VO-75	VA-295	VCA-1173	
Sonic				
4 cyl. 1.4L Turbo	VO-98 ^{X907} VO-173 ^{Z907}	VA-426	VCA-1078C ^{X401} VCA-1078 ^{Z401}	NS ⁴³⁷
4 cyl. 1.8L	VO-98 ^{X907} VO-173 ^{Z907}	VA-426	VCA-1078C ^{X401} VCA-1078 ^{Z401}	NS ⁴³⁷
Spark				
Electric			VCA-1078C ^{X401} VCA-1078 ^{Z401}	
4 cyl. 1.4L	VO-160		VCA-1078C ^{X401} VCA-1078 ^{Z401}	NS ⁴³⁷
SS				
V8 6.2	VO-88	VA-375		NS ⁴³⁷

Se reporter à table de matière pour les notes en bas de page en français. Utilize el contenido para ver notas a pie.

NS - Non-Serviceable / Non réparable / No reparable LF - Life-Time Filter / Filtro para toda la vida / Filtre à vie

⁴³⁷ Requires replacement of the complete fuel pump/fuel filter module. ^{X401}Dust and Odor filter ^{X907}With oil filter housing marked Hengst. ^{Z401}Dust filter

^{Z907}With oil filter housing marked UFI



CHEVROLET (cont'd)

2016

Suburban, Tahoe

V8 5.3L (Flex Fuel)	VO-88	VA-259	VCA-1173	NS ⁴³⁷
---------------------	-------	--------	----------	-------------------

Suburban 3500 HD

V8 6.0L (Flex Fuel)	VO-88	VA-259		NS ⁴³⁷
---------------------	-------	--------	--	-------------------

Traverse

V6 3.6L	VO-88	VA-225	VCA-1080	NS ⁴³⁷
---------	-------	--------	----------	-------------------

Trax

4 cyl. 1.4 Turbo	VO-98 ^{X907} VO-173 ^{Z907}	VA-424	VCA-1078C ^{X401} VCA-1078 ^{Z401}	NS ⁴³⁷
------------------	---	--------	---	-------------------

Volt

4 cyl 1.5L FI (Electric/gas)	VO-160		VCA-1078C ^{X401} VCA-1078 ^{Z401}	NS ⁴³⁷
------------------------------	--------	--	---	-------------------

2015

Camaro

V6 3.6L	VO-67	VA-280	VCA-1076	NS ⁴³⁷
V8 6.2L	VO-88	VA-280	VCA-1076	NS ⁴³⁷
V8 6.2L Supercharged	VO-88	VA-280	VCA-1076	NS ⁴³⁷
V8 7.0L	VO-152		VCA-1076	NS ⁴³⁷

Caprice

V6 3.6L (Flex Fuel)	VO-67	VA-375		NS ⁴³⁷
V8 6.0L (Flex Fuel)	VO-88	VA-375		NS ⁴³⁷

Captiva Sport

L4 2.4L (Flex Fuel)	VO-76	VA-236	VCA-1075	NS ⁴³⁷
---------------------	-------	--------	----------	-------------------

City Express

4 cyl. 2.0	VO-106	VA-244		NS ⁴³⁷
------------	--------	--------	--	-------------------

Colorado

4 cyl. 2.5L	VO-200	VA-425	VCA-1184	NS ⁴³⁷
V6 3.6L	VO-67	VA-425	VCA-1184	NS ⁴³⁷

Corvette

V8 6.2L (7)	VO-200			NS ⁴³⁷
V8 6.2L (6) (S.C.)	VO-200			NS ⁴³⁷

Cruze

4 cyl. 1.4L Turbo	VO-98 ^{X907} VO-173 ^{Z907}	VA-296	VCA-1078C ^{X401} VCA-1078 ^{Z401}	NS ⁴³⁷
4 cyl. 1.8L	VO-98 ^{X907} VO-173 ^{Z907}	VA-285	VCA-1078C ^{X401} VCA-1078 ^{Z401}	NS ⁴³⁷
4 cyl. 2.0L Diesel Turbo	VO-153	VA-296	VCA-1078C ^{X401} VCA-1078 ^{Z401}	

Equinox

4 cyl 2.4L	VO-76	VA-255	VCA-1075	NS ⁴³⁷
V6 3.6L	VO-88	VA-255	VCA-1075	NS ⁴³⁷

Express Van

V8 4.8L (Flex Fuel)	VO-88	VA-169		NS ⁴³⁷
V8 6.0L (B) (CNG)	VO-88	VA-169		
V8 6.0L (G) (Flex Fuel)	VO-88	VA-169		NS ⁴³⁷
V8 6.6L Diesel Turbo	VO-75	VA-381		

Impala

4 cyl. 2.5L (L) FI	VO-200	VA-308	VCA-1184	NS ⁴³⁷
V6 3.6L	VO-88	VA-308	VCA-1184	NS ⁴³⁷

Se reporter à table de matière pour les notes en bas de page en français. Utilize el contenido para ver notas a pie.

NS - Non-Serviceable / Non réparable / No reparable. LF - Life-Time Filter / Filtro para toda la vida / Filtre à vie

⁴³⁷ Requires replacement of the complete fuel pump/fuel filter module. ^{X401}Dust and Odor filter ^{X907}With oil filter housing marked Hengst. ^{Z401}Dust filter

^{Z907}With oil filter housing marked UFI



CHEVROLET (cont'd)

	Oil	Air	Cabin*	Fuel
2015				
Impala Limited				
V6 3.6L (Flex Fuel)	VO-88	VA-299	VCA-1002	NS ⁴³⁷
Malibu				
4 cyl. 2.0L Turbo	VO-200	VA-308	VCA-1078C ^{X401} VCA-1078 ^{Z401}	NS ⁴³⁷
4 cyl. 2.5L	VO-200	VA-308	VCA-1078C ^{X401} VCA-1078 ^{Z401}	NS ⁴³⁷
Silverado Pickup				
V6 4.3L	VO-88	VA-259	VCA-1173	NS ⁴³⁷
V8 5.3L Gas/Flex	VO-88	VA-259	VCA-1173	NS ⁴³⁷
V8 6.0L	VO-88	VA-259	VCA-1173	NS ⁴³⁷
V8 6.2L	VO-88	VA-259	VCA-1173	NS ⁴³⁷
V8 6.6L Diesel Turbo	VO-75	VA-295	VCA-1173	
Sonic				
4 cyl. 1.4L Turbo	VO-98 ^{X907} VO-173 ^{Z907}	VA-426	VCA-1078C ^{X401} VCA-1078 ^{Z401}	NS ⁴³⁷
4 cyl. 1.8L	VO-98 ^{X907} VO-173 ^{Z907}	VA-426	VCA-1078C ^{X401} VCA-1078 ^{Z401}	NS ⁴³⁷
Spark				
Electric			VCA-1078C ^{X401} VCA-1078 ^{Z401}	
4 cyl. 1.2L	VO-123	VA-427	VCA-1078C ^{X401} VCA-1078 ^{Z401}	
SS				
V8 6.2	VO-88	VA-375		NS ⁴³⁷
Suburban, Tahoe				
V8 5.3L (Flex Fuel)	VO-88	VA-259	VCA-1173	NS ⁴³⁷
Traverse				
V6 3.6L	VO-88	VA-225	VCA-1080	NS ⁴³⁷
Trax				
4 cyl. 1.4 Turbo	VO-98 ^{X907} VO-173 ^{Z907}	VA-424	VCA-1078C ^{X401} VCA-1078 ^{Z401}	NS ⁴³⁷
Volt				
4 cyl 1.4L FI (Electric/gas)	VO-122	VA-327	VCA-1078C ^{X401} VCA-1078 ^{Z401}	NS ⁴³⁷
2014				
Camaro				
V6 3.6L	VO-67	VA-280	VCA-1076	NS ⁴³⁷
V8 6.2L	VO-88	VA-280	VCA-1076	NS ⁴³⁷
V8 6.2L Supercharged	VO-88	VA-280	VCA-1076	NS ⁴³⁷
V8 7.0L	VO-152		VCA-1076	NS ⁴³⁷
Caprice				
V6 3.6L (Flex Fuel)	VO-67	VA-375		NS ⁴³⁷
V8 6.0L (Flex Fuel)	VO-88	VA-375		NS ⁴³⁷
Captiva Sport				
L4 2.4L (Flex Fuel)	VO-76	VA-236	VCA-1075	NS ⁴³⁷
Corvette				
V8 6.2L	VO-200			NS ⁴³⁷

Se reporter à table de matière pour les notes en bas de page en français. Utilize el contenido para ver notas a pie.

NS - Non-Serviceable / Non réparable / No reparable LF - Life-Time Filter / Filtro para toda la vida / Filtre à vie

⁴³⁷ Requires replacement of the complete fuel pump/fuel filter module. ^{X401} Dust and Odor filter ^{X907} With oil filter housing marked Hengst. ^{Z401} Dust filter

^{Z907} With oil filter housing marked UFI



CHEVROLET (cont'd)

2014

Cruze

4 cyl. 1.4L Turbo	VO-98	VA-296	VCA-1078C ^{X401} VCA-1078 ^{Z401}	NS ⁴³⁷
4 cyl. 1.8L	VO-98	VA-285	VCA-1078C ^{X401} VCA-1078 ^{Z401}	NS ⁴³⁷
4 cyl. 2.0L Diesel Turbo	VO-153	VA-296	VCA-1078C ^{X401} VCA-1078 ^{Z401}	

Equinox

4 cyl 2.4L	VO-76	VA-255	VCA-1075	NS ⁴³⁷
V6 3.6L	VO-88	VA-255	VCA-1075	NS ⁴³⁷

Express Van

V6 4.3L	VO-16	VA-169		NS ⁴³⁷
V8 4.8L (A) FI (Flex Fuel)	VO-88	VA-169		NS ⁴³⁷
V8 5.3L (4) FI (Flex Fuel)	VO-88	VA-169		NS ⁴³⁷
V8 6.0L (B) FI (CNG)	VO-88	VA-169		
V8 6.0L (G) FI Flex Fuel	VO-88	VA-169		NS ⁴³⁷
V8 6.6L (L) Diesel Turbo	VO-75	VA-381		

Impala

4 cyl. 2.4L Hybrid	VO-76	VA-254	VCA-1184 ^{X788} VCA-1183 ^{Z788}	NS ⁴³⁷
4 cyl. 2.5L	VO-200	VA-308	VCA-1184 ^{X788} VCA-1183 ^{Z788}	NS ⁴³⁷
V6 3.6L	VO-88	VA-308	VCA-1184 ^{X788} VCA-1183 ^{Z788}	NS ⁴³⁷

Impala Limited

V6 3.6L (Flex Fuel)	VO-88	VA-299	VCA-1002	NS ⁴³⁷
---------------------	-------	--------	----------	-------------------

Malibu

4 cyl. 2.0L Turbo	VO-200	VA-308	VCA-1078C ^{X401} VCA-1078 ^{Z401}	NS ⁴³⁷
4 cyl. 2.4L Hybrid	VO-76	VA-254	VCA-1078C ^{X401} VCA-1078 ^{Z401}	NS ⁴³⁷
4 cyl. 2.5L (L)	VO-200	VA-308	VCA-1078C ^{X401} VCA-1078 ^{Z401}	NS ⁴³⁷

Orlando (Canada)

4 cyl. 2.4L (Flex Fuel)	VO-76	VA-296	VCA-1078C ^{X401} VCA-1078 ^{Z401}	NS ⁴³⁷
-------------------------	-------	--------	---	-------------------

Silverado Pickup

V6 4.3L	VO-88	VA-259	VCA-1173	NS ⁴³⁷
V8 5.3L Gas/Flex	VO-88	VA-259	VCA-1173	NS ⁴³⁷
V8 6.0L	VO-88	VA-259		NS ⁴³⁷
V8 6.0L (CNG)	VO-88	VA-259		NS ⁴³⁷
V8 6.2L	VO-88	VA-259	VCA-1173	NS ⁴³⁷
V8 6.6L Diesel Turbo	VO-75	VA-295		

Sonic

4 cyl. 1.4L Turbo	VO-98 ^{X907} VO-173 ^{Z907}	VA-426	VCA-1078C ^{X401} VCA-1078 ^{Z401}	NS ⁴³⁷
4 cyl. 1.8L	VO-98 ^{X907} VO-173 ^{Z907}	VA-426	VCA-1078C ^{X401} VCA-1078 ^{Z401}	NS ⁴³⁷

Spark

Electric			VCA-1078C ^{X401} VCA-1078 ^{Z401}	
----------	--	--	---	--

Se reporter à table de matière pour les notes en bas de page en français. Utilize el contenido para ver notas a pie.

NS - Non-Serviceable / Non réparable / No reparable LF - Life-Time Filter / Filtro para toda la vida / Filtro a vie

⁴³⁷ Requires replacement of the complete fuel pump/fuel filter module. ^{X401}Dust and Odor filter ^{X788}Dust ^{X907}With oil filter housing marked Hengst.

^{Z401}Dust filter ^{Z788}Dust and Odor ^{Z907}With oil filter housing marked UFI



CHEVROLET (cont'd)

	Oil	Air	Cabin*	Fuel
2014				
Spark				
4 cyl. 1.2L	VO-123	VA-427	VCA-1078C ^{X401} VCA-1078 ^{Z401}	
SS				
V8 6.2	VO-88	VA-375		NS ⁴³⁷
Suburban, Tahoe				
V8 5.3L (Flex Fuel)	VO-88	VA-259		NS ⁴³⁷
Traverse				
V6 3.6L	VO-88	VA-225	VCA-1080	NS ⁴³⁷
Trax				
4 cyl. 1.4 Turbo	VO-98 ^{X907} VO-173 ^{Z907}	VA-424	VCA-1078C ^{X401} VCA-1078 ^{Z401}	NS ⁴³⁷
Volt				
4 cyl 1.4L FI (Electric/gas)	VO-122	VA-327	VCA-1078C ^{X401} VCA-1078 ^{Z401}	NS ⁴³⁷
2013				
Avalanche				
V8 5.3L (0,7) FI (Flex Fuel)	VO-88	VA-259		NS ⁴³⁷
Camaro				
V6 3.6L	VO-67	VA-280	VCA-1076	NS ⁴³⁷
V8 6.2L	VO-88	VA-280	VCA-1076	NS ⁴³⁷
V8 6.2L Supercharged	VO-88	VA-280	VCA-1076	NS ⁴³⁷
Caprice				
V6 3.6L (Flex Fuel)	VO-67	VA-375		NS ⁴³⁷
V8 6.0L (Flex Fuel)	VO-88	VA-375		NS ⁴³⁷
Captiva Sport				
L4 2.4L (Flex Fuel)	VO-76	VA-236	VCA-1075	NS ⁴³⁷
Corvette				
V8 6.2L (W)	VO-88			NS ⁴³⁷
V8 6.2L (T) (S.C.)	VO-152			NS ⁴³⁷
V8 7.0L (E)	VO-152			NS ⁴³⁷
Cruze				
4 cyl. 1.4L Turbo	VO-98	VA-296	VCA-1078C ^{X401} VCA-1078 ^{Z401}	NS ⁴³⁷
4 cyl. 1.8L	VO-98	VA-285	VCA-1078C ^{X401} VCA-1078 ^{Z401}	NS ⁴³⁷
Equinox				
4 cyl 2.4L	VO-76	VA-255	VCA-1075	NS ⁴³⁷
V6 3.6L	VO-88	VA-255	VCA-1075	NS ⁴³⁷
Express Van				
V6 4.3L (X) FI	VO-16	VA-169		NS ⁴³⁷
V8 4.8L (A) FI (Flex Fuel)	VO-88	VA-169		NS ⁴³⁷
V8 5.3L (4) FI (Flex Fuel)	VO-88	VA-169		NS ⁴³⁷
V8 6.0L (B) FI (CNG/LPG)	VO-88	VA-169		NS ⁴³⁷
V8 6.0L (G) FI (Flex Fuel)	VO-88	VA-169		NS ⁴³⁷
V8 6.6L (L) Diesel Turbo	VO-75	VA-381		NS ⁴³⁷
Impala				
V6 3.6L	VO-88	VA-299	VCA-1002	NS ⁴³⁷
Malibu				
4 cyl. 2.0L Turbo	VO-200	VA-308	VCA-1078C ^{X401} VCA-1078 ^{Z401}	NS ⁴³⁷

Se reporter à table de matière pour les notes en bas de page en français. Utilize el contenido para ver notas a pie.

NS - Non-Serviceable / Non réparable / No reparable LF - Life-Time Filter / Filtro para toda la vida / Filtre à vie

⁴³⁷ Requires replacement of the complete fuel pump/fuel filter module. ^{X401}Dust and Odor filter ^{X907}With oil filter housing marked Hengst. ^{Z401}Dust filter

^{Z907}With oil filter housing marked UFI



CHEVROLET (cont'd)

2013

Malibu

4 cyl. 2.4L Hybrid	VO-76	VA-254	VCA-1078C ^{X401} VCA-1078 ^{Z401}	NS ⁴³⁷
4 cyl. 2.5L	VO-200	VA-308	VCA-1078C ^{X401} VCA-1078 ^{Z401}	NS ⁴³⁷

Orlando (Canada)

4 cyl. 2.4L	VO-76	VA-296	VCA-1078C ^{X401} VCA-1078 ^{Z401}	NS ⁴³⁷
-------------	-------	--------	---	-------------------

Silverado Pickup

V6 4.3L	VO-16	VA-259		NS ⁴³⁷
V8 4.8L	VO-88	VA-259		NS ⁴³⁷
V8 5.3L	VO-88	VA-259		NS ⁴³⁷
V8 6.0L (CNG/LPG)	VO-88	VA-259		NS ⁴³⁷
V8 6.0L (J) FI (Hybrid)	VO-88	VA-259		NS ⁴³⁷
V8 6.0L GAS	VO-88	VA-259		NS ⁴³⁷
V8 6.2L	VO-88	VA-259		NS ⁴³⁷
V8 6.6L (8) Diesel Turbo	VO-75	VA-295		NS ⁴³⁷

Sonic

4 cyl. 1.4L Turbo	VO-98 ^{X907} VO-173 ^{Z907}	VA-426	VCA-1078C ^{X401} VCA-1078 ^{Z401}	NS ⁴³⁷
4 cyl. 1.8L	VO-98 ^{X907} VO-173 ^{Z907}	VA-426	VCA-1078C ^{X401} VCA-1078 ^{Z401}	NS ⁴³⁷

Spark

4 cyl. 1.2L	VO-123	VA-427	VCA-1078C ^{X401} VCA-1078 ^{Z401}	
-------------	--------	--------	---	--

Suburban, Tahoe

V8 5.3L (0,7) (Flex Fuel)	VO-88	VA-259		NS ⁴³⁷
V8 6.0L (G) (Flex Fuel)	VO-88	VA-259		NS ⁴³⁷
V8 6.0L (J) FI (Flex Fuel Hybrid)	VO-88	VA-259		NS ⁴³⁷

Traverse

V6 3.6L	VO-88	VA-225	VCA-1080	NS ⁴³⁷
---------	-------	--------	----------	-------------------

Trax

4 cyl. 1.4 Turbo	VO-98 ^{X907} VO-173 ^{Z907}	VA-424	VCA-1078C ^{X401} VCA-1078 ^{Z401}	NS ⁴³⁷
------------------	---	--------	---	-------------------

Volt

4 cyl 1.4L FI (Electric/gas)	VO-122	VA-327	VCA-1078C ^{X401} VCA-1078 ^{Z401}	NS ⁴³⁷
------------------------------	--------	--------	---	-------------------

2012

Avalanche

V8 5.3L (0,7) FI (Flex Fuel)	VO-88	VA-259		NS ⁴³⁷
------------------------------	-------	--------	--	-------------------

Camaro

V6 3.6L	VO-67	VA-280	VCA-1076	NS ⁴³⁷
V8 6.2L (J,W) FI	VO-88	VA-280	VCA-1076	NS ⁴³⁷
V8 6.2L (P) Supercharged	VO-88	VA-280	VCA-1076	NS ⁴³⁷

Caprice

V6 3.6L FI (Flex Fuel)	VO-67	VA-375		NS ⁴³⁷
V8 6.0L FI (Flex Fuel)	VO-88	VA-375		NS ⁴³⁷

Captiva Sport

L4 2.4L (Flex Fuel)	VO-76	VA-236	VCA-1075	NS ⁴³⁷
V6 3.0L (Flex Fuel)	VO-200	VA-236	VCA-1075	NS ⁴³⁷

Se reporter à table de matière pour les notes en bas de page en français. Utilize el contenido para ver notas a pie.

NS - Non-Serviceable / Non réparable / No reparable LF - Life-Time Filter / Filtro para toda la vida / Filtre à vie

⁴³⁷ Requires replacement of the complete fuel pump/fuel filter module. ^{X401}Dust and Odor filter ^{X907}With oil filter housing marked Hengst. ^{Z401}Dust filter

^{Z907}With oil filter housing marked UFI



CHEVROLET (cont'd)

	Oil	Air	Cabin*	Fuel
2012				
Colorado				
4 cyl. 2.9L	VO-58	VA-219		NS ⁴³⁷
5 cyl. 3.7L	VO-108	VA-219		NS ⁴³⁷
V8 5.3L	VO-88	VA-219		NS ⁴³⁷
Corvette				
V8 6.2L (W)	VO-88			NS ⁴³⁷
V8 6.2L (T) (S.C.)	VO-152			NS ⁴³⁷
V8 7.0L (E)	VO-152			NS ⁴³⁷
Cruze				
4 cyl. 1.4L Turbo	VO-98	VA-296	VCA-1078C ^{X401} VCA-1078 ^{Z401}	NS ⁴³⁷
4 cyl. 1.8L	VO-98	VA-285	VCA-1078C ^{X401} VCA-1078 ^{Z401}	NS ⁴³⁷
Equinox				
4 cyl. 2.4L	VO-76	VA-255	VCA-1075	NS ⁴³⁷
V6 3.0L	VO-88	VA-255	VCA-1075	NS ⁴³⁷
Express Van				
V6 4.3L (X) FI	VO-16	VA-169		NS ⁴³⁷
V8 4.8L (A) FI (Flex Fuel)	VO-88	VA-169		NS ⁴³⁷
V8 5.3L (4) FI (Flex Fuel)	VO-88	VA-169		NS ⁴³⁷
V8 6.0L (B) FI (CNG)	VO-88	VA-169		NS ⁴³⁷
V8 6.0L (G) FI (Flex Fuel)	VO-88	VA-169		NS ⁴³⁷
V8 6.6L (L) Diesel Turbo	VO-75	VA-381		NS ⁴³⁷
Impala				
V6 3.6L	VO-88	VA-299	VCA-1002	NS ⁴³⁷
Malibu				
4 cyl. 2.4L	VO-76	VA-176		NS ⁴³⁷
V6 3.6L	VO-88	VA-176		NS ⁴³⁷
Orlando (Canada)				
4 cyl. 2.4L	VO-76	VA-296	VCA-1078C ^{X401} VCA-1078 ^{Z401}	NS ⁴³⁷
Silverado Pickup				
V6 4.3L	VO-16	VA-259		NS ⁴³⁷
V8 4.8L (Flex Fuel)	VO-88	VA-259		NS ⁴³⁷
V8 5.3L	VO-88	VA-259		NS ⁴³⁷
V8 6.0L (G)	VO-88	VA-259		NS ⁴³⁷
V8 6.0L (J) (Hybrid)	VO-88	VA-259		NS ⁴³⁷
V8 6.2L (2)	VO-88	VA-259		NS ⁴³⁷
V8 6.6L (8,L) Diesel Turbo	VO-75	VA-295		NS ⁴³⁷
Sonic				
4 cyl. 1.4L Turbo	VO-98	VA-426	VCA-1078C ^{X401} VCA-1078 ^{Z401}	NS ⁴³⁷
4 cyl. 1.8L	VO-98	VA-426	VCA-1078C ^{X401} VCA-1078 ^{Z401}	NS ⁴³⁷
Suburban, Tahoe				
V8 5.3L (3,0) (Flex Fuel)	VO-88	VA-259		NS ⁴³⁷
V8 6.0L (G) (Flex Fuel)	VO-88	VA-259		NS ⁴³⁷
V8 6.0L (J) FI (Flex Fuel Hybrid)	VO-88	VA-259		NS ⁴³⁷
Traverse				
V6 3.6L	VO-88	VA-225	VCA-1080	NS ⁴³⁷
Volt				
4 cyl. 1.4L FI (Electric/gas)	VO-122	VA-327	VCA-1078C ^{X401} VCA-1078 ^{Z401}	NS ⁴³⁷

Se reporter à table de matière pour les notes en bas de page en français. Utilize el contenido para ver notas a pie.

NS - Non-Serviceable / Non réparable / No reparable LF - Life-Time Filter / Filtro para toda la vida / Filtre à vie

⁴³⁷ Requires replacement of the complete fuel pump/fuel filter module. ^{X401}Dust and Odor filter ^{Z401}Dust filter



CHEVROLET (cont'd)

2011

Avalanche

V8 5.3L (0,3) FI (Flex Fuel)	VO-88	VA-259		NS ⁴³⁷
------------------------------	-------	--------	--	-------------------

Aveo

4 cyl. 1.6L FI	VO-98	VA-188	VCA-1146	
----------------	-------	--------	----------	--

Camaro

V6 3.6L	VO-67	VA-280	VCA-1076	NS ⁴³⁷
---------	-------	--------	----------	-------------------

V8 6.2L	VO-88	VA-280	VCA-1076	NS ⁴³⁷
---------	-------	--------	----------	-------------------

Caprice

V8 6.0L FI (Flex Fuel)	VO-88	VA-375		NS ⁴³⁷
------------------------	-------	--------	--	-------------------

Colorado

4 cyl. 2.9L	VO-58	VA-219		NS ⁴³⁷
-------------	-------	--------	--	-------------------

5 cyl. 3.7L	VO-108	VA-219		NS ⁴³⁷
-------------	--------	--------	--	-------------------

V8 5.3L	VO-88	VA-219		NS ⁴³⁷
---------	-------	--------	--	-------------------

Corvette

V8 6.2L (W)	VO-88			NS ⁴³⁷
-------------	-------	--	--	-------------------

V8 6.2L (T) (S.C.)	VO-152			NS ⁴³⁷
--------------------	--------	--	--	-------------------

V8 7.0L (E)	VO-152			NS ⁴³⁷
-------------	--------	--	--	-------------------

Cruze

4 cyl. 1.4L Turbo	VO-98	VA-296	VCA-1078C ^{X401} VCA-1078 ^{Z401}	NS ⁴³⁷
-------------------	-------	--------	---	-------------------

4 cyl. 1.8L	VO-98	VA-285	VCA-1078C ^{X401} VCA-1078 ^{Z401}	NS ⁴³⁷
-------------	-------	--------	---	-------------------

Equinox

4 cyl 2.4L	VO-76	VA-255	VCA-1075	NS ⁴³⁷
------------	-------	--------	----------	-------------------

V6 3.0L	VO-88	VA-255	VCA-1075	NS ⁴³⁷
---------	-------	--------	----------	-------------------

Express Van

V6 4.3L (X) FI	VO-16	VA-169		NS ⁴³⁷
----------------	-------	--------	--	-------------------

V8 4.8L (A) FI (Flex Fuel)	VO-88	VA-169		NS ⁴³⁷
----------------------------	-------	--------	--	-------------------

V8 5.3L (4) FI (Flex Fuel)	VO-88	VA-169		NS ⁴³⁷
----------------------------	-------	--------	--	-------------------

V8 6.0L (B) FI (CNG)	VO-88	VA-169		NS ⁴³⁷
----------------------	-------	--------	--	-------------------

V8 6.0L (G) FI (Flex Fuel)	VO-88	VA-169		NS ⁴³⁷
----------------------------	-------	--------	--	-------------------

V8 6.6L (L) Diesel Turbo	VO-75	VA-381		NS ⁴³⁷
--------------------------	-------	--------	--	-------------------

HHR

4 cyl 2.2L (W) FI (Flex Fuel)	VO-76	VA-217	VCA-1065	NS ⁴³⁷
-------------------------------	-------	--------	----------	-------------------

4 cyl 2.4L (U) FI (Flex Fuel)	VO-76	VA-217	VCA-1065	NS ⁴³⁷
-------------------------------	-------	--------	----------	-------------------

Impala

V6 3.5L (K) FI (Flex Fuel)	VO-108	VA-200	VCA-1002	NS ⁴³⁷
----------------------------	--------	--------	----------	-------------------

V6 3.9L (M) FI (Flex Fuel)	VO-108	VA-200	VCA-1002	NS ⁴³⁷
----------------------------	--------	--------	----------	-------------------

Malibu

4 cyl. 2.4L	VO-76	VA-176		NS ⁴³⁷
-------------	-------	--------	--	-------------------

V6 3.6L	VO-88	VA-176		NS ⁴³⁷
---------	-------	--------	--	-------------------

Silverado Pickup

V6 4.3L	VO-16	VA-259		NS ⁴³⁷
---------	-------	--------	--	-------------------

V8 4.8L	VO-88	VA-259		NS ⁴³⁷
---------	-------	--------	--	-------------------

V8 5.3L	VO-88	VA-259		NS ⁴³⁷
---------	-------	--------	--	-------------------

V8 6.0L (G)	VO-88	VA-259		NS ⁴³⁷
-------------	-------	--------	--	-------------------

V8 6.0L (J) (Hybrid)	VO-88	VA-259		NS ⁴³⁷
----------------------	-------	--------	--	-------------------

V8 6.2L (2)	VO-88	VA-259		NS ⁴³⁷
-------------	-------	--------	--	-------------------

V8 6.6L (8,L) Diesel Turbo	VO-75	VA-295		NS ⁴³⁷
----------------------------	-------	--------	--	-------------------

Suburban, Tahoe

V8 5.3L (3,0) FI (Flex Fuel)	VO-88	VA-259		NS ⁴³⁷
------------------------------	-------	--------	--	-------------------

V8 6.0L (J) FI (Flex Fuel Hybrid)	VO-88	VA-259		NS ⁴³⁷
-----------------------------------	-------	--------	--	-------------------

V8 6.0L (G) FI (Flex Fuel)	VO-88	VA-259		NS ⁴³⁷
----------------------------	-------	--------	--	-------------------

Se reporter à table de matière pour les notes en bas de page en français. Utilize el contenido para ver notas a pie.

NS - Non-Serviceable / Non réparable / No repairable LF - Life-Time Filter / Filtro para toda la vida / Filtre à vie

⁴³⁷ Requires replacement of the complete fuel pump/fuel filter module. ^{X401}Dust and Odor filter ^{Z401}Dust filter



CHEVROLET (cont'd)

	Oil	Air	Cabin*	Fuel
2011				
Traverse				
V6 3.6L	VO-88	VA-225	VCA-1080	NS ⁴³⁷
Volt				
4 cyl. 1.4L FI (Electric/gas)	VO-122	VA-327	VCA-1078C ^{X401} VCA-1078 ^{Z401}	NS ⁴³⁷
2010				
Avalanche				
V8 5.3L (0) FI (Flex Fuel)	VO-88	VA-259		NS ⁴³⁷
Aveo				
4 cyl. 1.6L FI	VO-98	VA-188	VCA-1146	
Camaro				
V6 3.6L	VO-67	VA-280	VCA-1076	NS ⁴³⁷
V8 6.2L	VO-88	VA-280	VCA-1076	NS ⁴³⁷
Cobalt				
4 cyl. 2.0L (X) FI Turbo	VO-76		VCA-1065	
4 cyl. 2.2L (5) FI	VO-76	VA-203	VCA-1065	
Colorado				
4 cyl. 2.9L (9) FI	VO-58	VA-219		NS ⁴³⁷
5 cyl. 3.7L (E) FI	VO-108	VA-219		NS ⁴³⁷
V8 5.3L (P) FI	VO-88	VA-219		NS ⁴³⁷
Corvette				
V8 6.2L (W)	VO-88			NS ⁴³⁷
V8 6.2L (R,T) (S.C.)	VO-152			NS ⁴³⁷
V8 7.0L (E)	VO-152			NS ⁴³⁷
Equinox				
4 cyl. 2.4L	VO-76	VA-255	VCA-1075	NS ⁴³⁷
V6 3.0L	VO-88	VA-255	VCA-1075	NS ⁴³⁷
Express Van				
V6 4.3L (X) FI	VO-16	VA-169		NS ⁴³⁷
V8 4.8L (A) FI (Flex Fuel)	VO-88	VA-169		NS ⁴³⁷
V8 5.3L (4) FI (Flex Fuel)	VO-88	VA-169		NS ⁴³⁷
V8 6.0L (G) FI (Flex Fuel)	VO-88	VA-169		NS ⁴³⁷
V8 6.6L (6,L) Diesel Turbo	VO-75	VA-381		
HHR				
4 cyl. 2.0L (M) FI Turbo	VO-76	VA-388	VCA-1065	NS ⁴³⁷
4 cyl. 2.2L (B) FI (Flex Fuel)	VO-76	VA-217	VCA-1065	NS ⁴³⁷
4 cyl. 2.4L (V) FI (Flex Fuel)	VO-76	VA-217	VCA-1065	NS ⁴³⁷
Impala				
V6 3.5L (N) FI	VO-108	VA-200	VCA-1002	NS ⁴³⁷
V6 3.5L (K) FI (Flex Fuel)	VO-108	VA-200	VCA-1002	NS ⁴³⁷
V6 3.9L (M) FI (Flex Fuel)	VO-108	VA-200	VCA-1002	NS ⁴³⁷
Malibu				
4 cyl. 2.4L Hybrid	VO-76	VA-176		NS ⁴³⁷
4 cyl. 2.4L	VO-76	VA-176		NS ⁴³⁷
V6 3.5L	VO-108	VA-176		NS ⁴³⁷
V6 3.6L	VO-88	VA-176		NS ⁴³⁷
Optra (Canada/Mexico)				
4 cyl. 2.0L FI	VO-16	VA-340	VCA-1155	
Silverado Pickup				
V6 4.3L (X) FI	VO-16	VA-259		NS ⁴³⁷
V8 4.8L (A) FI	VO-88	VA-259		NS ⁴³⁷
V8 5.3L (0,3) FI	VO-88	VA-259		NS ⁴³⁷
V8 6.0L (K) FI	VO-88	VA-259		NS ⁴³⁷

Se reporter à table de matière pour les notes en bas de page en français. Utilize el contenido para ver notas a pie.

NS - Non-Serviceable / Non réparable / No reparable LF - Life-Time Filter / Filtro para toda la vida / Filtre à vie

⁴³⁷ Requires replacement of the complete fuel pump/fuel filter module. ^{X401}Dust and Odor filter ^{Z401}Dust filter



CHEVROLET (cont'd)

2010

Silverado Pickup

V8 6.0L (G) FI (Flex Fuel)	VO-88	VA-259		NS ⁴³⁷
V8 6.0L (J) FI (Hybrid)	VO-88	VA-259		NS ⁴³⁷
V8 6.2L (2) FI	VO-88	VA-259		NS ⁴³⁷
V8 6.6L (6) Diesel Turbo	VO-75	VA-218		

Suburban, Tahoe

V8 5.3L (3,0) FI (Flex Fuel)	VO-88	VA-259		NS ⁴³⁷
V8 6.0L (J) FI (Flex Fuel Hybrid)	VO-88	VA-259		NS ⁴³⁷
V8 6.0L (G) FI (Flex Fuel)	VO-88	VA-259		NS ⁴³⁷

Traverse

V6 3.6L	VO-88	VA-225	VCA-1080	NS ⁴³⁷
---------	-------	--------	----------	-------------------

2009

Avalanche

V8 5.3L (J) FI	VO-88	VA-259		NS ⁴³⁷
V8 5.3L (0,3) FI (Flex Fuel)	VO-88	VA-259		NS ⁴³⁷
V8 6.0L (Y) FI	VO-88	VA-259		NS ⁴³⁷

Aveo

4 cyl. 1.6L FI	VO-98	VA-188	VCA-1146	
----------------	-------	--------	----------	--

Cobalt

4 cyl. 2.0L (X) FI Turbo	VO-76		VCA-1065	
4 cyl. 2.2L (H) FI	VO-76	VA-203	VCA-1065	

Colorado

4 cyl. 2.9L (9) FI	VO-58	VA-219		NS ⁴³⁷
5 cyl. 3.7L (E) FI	VO-108	VA-219		NS ⁴³⁷
V8 5.3L (L) FI	VO-88	VA-219		NS ⁴³⁷

Corvette

V8 6.2L (W) FI	VO-88			NS ⁴³⁷
V8 6.2L (R) FI (S.C.)	VO-152			NS ⁴³⁷
V8 7.0L (E) FI	VO-152			NS ⁴³⁷

Equinox

V6 3.4L (F) FI	VO-16	VA-176	VCA-1030	NS ⁴³⁷
V6 3.6L (7) FI	VO-88	VA-176	VCA-1030	NS ⁴³⁷

Express Van

V6 4.3L (X) FI	VO-16	VA-169		NS ⁴³⁷
V8 4.8L (C) FI	VO-88	VA-169		NS ⁴³⁷
V8 5.3L (4) FI	VO-88	VA-169		NS ⁴³⁷
V8 6.0L (K) FI	VO-88	VA-169		NS ⁴³⁷
V8 6.6L (6) Diesel Turbo	VO-75	VA-381		

HHR

4 cyl 2.0L (X) FI Turbo	VO-76	VA-388	VCA-1065	NS ⁴³⁷
4 cyl 2.2L (B) FI (Flex Fuel)	VO-76	VA-217	VCA-1065	NS ⁴³⁷
4 cyl 2.4L (V) FI (Flex Fuel)	VO-76	VA-217	VCA-1065	NS ⁴³⁷

Impala

V6 3.5L (N) FI	VO-108	VA-200	VCA-1002	NS ⁴³⁷
V6 3.5L (K) FI (Flex Fuel)	VO-108	VA-200	VCA-1002	NS ⁴³⁷
V6 3.9L (3,M) FI (Flex Fuel)	VO-108	VA-200	VCA-1002	NS ⁴³⁷
V8 5.3L (C) FI	VO-88	VA-200	VCA-1002	NS ⁴³⁷

Malibu

4 cyl 2.4L Hybrid	VO-76	VA-176		NS ⁴³⁷
4 cyl. 2.4L Non Hybrid	VO-76	VA-176		NS ⁴³⁷
V6 3.5L (K,N) FI	VO-108	VA-176		NS ⁴³⁷
V6 3.6L (7) FI	VO-88	VA-176		NS ⁴³⁷

Se reporter à table de matière pour les notes en bas de page en français. Utilize el contenido para ver notas a pie.

NS - Non-Serviceable / Non réparable / No repairable LF - Life-Time Filter / Filtro para toda la vida / Filtre à vie

⁴³⁷ Requires replacement of the complete fuel pump/fuel filter module.



CHEVROLET (cont'd)

2009

Optra (Canada/Mexico)

4 cyl. 2.0L FI	VO-16	VA-340	VCA-1155	
----------------	-------	--------	----------	--

Silverado Pickup

V6 4.3L (X) FI	VO-16	VA-259		NS ⁴³⁷
V8 4.8L (C) FI	VO-88	VA-259		NS ⁴³⁷
V8 5.3L FI	VO-88	VA-259		NS ⁴³⁷
V8 6.0L (Y) FI	VO-88	VA-259		NS ⁴³⁷
V8 6.0L (K) FI	VO-88	VA-259		NS ⁴³⁷
V8 6.0L (5) FI (Hybrid)	VO-88	VA-259		NS ⁴³⁷
V8 6.2L (2,8) FI	VO-88	VA-259		NS ⁴³⁷
V8 6.6L (6) Diesel Turbo	VO-75	VA-218		

Suburban, Tahoe

V8 4.8L (C) FI	VO-88	VA-259		NS ⁴³⁷
V8 5.3L (J) FI	VO-88	VA-259		NS ⁴³⁷
V8 5.3L (3,0) FI (Flex Fuel)	VO-88	VA-259		NS ⁴³⁷
V8 6.0L (K) FI	VO-88	VA-259		NS ⁴³⁷
V8 6.0L (Y) FI	VO-88	VA-259		NS ⁴³⁷
V8 6.0L (5) FI (Hybrid)	VO-88	VA-259		NS ⁴³⁷
V8 6.2L (2) FI (Flex Fuel)	VO-88	VA-259		NS ⁴³⁷

Trailblazer

6 cyl. 4.2L (S) FI	VO-108	VA-161		NS ⁴³⁷
V8 6.0L (H) FI	VO-88	VA-161		NS ⁴³⁷

Traverse

V6 3.6L	VO-88	VA-225	VCA-1080	NS ⁴³⁷
---------	-------	--------	----------	-------------------

Uplander

V6 3.9L (1,W) FI	VO-108	VA-109	VCA-1164	NS ⁴³⁷
------------------	--------	--------	----------	-------------------

2008

Avalanche

V8 5.3L (J) FI	VO-88	VA-259		NS ⁴³⁷
V8 5.3L (3,0) FI (Flex Fuel)	VO-88	VA-259		NS ⁴³⁷
V8 6.0L (Y) FI	VO-88	VA-259		NS ⁴³⁷

Aveo

4 cyl. 1.6L FI	VO-16	VA-188	VCA-1146	
----------------	-------	--------	----------	--

Cobalt

4 cyl. 2.0L (X) FI Turbo	VO-76		VCA-1065	
4 cyl. 2.2L (F) FI	VO-76	VA-203	VCA-1065	
4 cyl. 2.4L (B) FI	VO-76	VA-203	VCA-1065	

Colorado

4 cyl. 2.9L (9) FI	VO-58	VA-219		NS ⁴³⁷
5 cyl. 3.7L (E) FI	VO-108	VA-219		NS ⁴³⁷

Corvette

V8 6.2L (W) FI	VO-88			NS ⁴³⁷
V8 7.0L (E) FI	VO-152			NS ⁴³⁷

Equinox

V6 3.4L (F) FI	VO-16	VA-176	VCA-1030	NS ⁴³⁷
V6 3.6L (7) FI	VO-88	VA-176	VCA-1030	NS ⁴³⁷

Express Van

V6 4.3L (X) FI	VO-16	VA-169		NS ⁴³⁷
V8 4.8L (C) FI	VO-88	VA-169		NS ⁴³⁷
V8 5.3L (4) FI	VO-88	VA-169		NS ⁴³⁷
V8 6.0L (K) FI	VO-88	VA-169		NS ⁴³⁷
V8 6.6L (6) Diesel Turbo	VO-75	VA-381		

Se reporter à table de matière pour les notes en bas de page en français. Utilize el contenido para ver notas a pie.

NS - Non-Serviceable / Non réparable / No repairable LF - Life-Time Filter / Filtro para toda la vida / Filtre à vie

⁴³⁷ Requires replacement of the complete fuel pump/fuel filter module.



CHEVROLET (cont'd)

2008

HHR

4 cyl 2.0L (X) FI Turbo	VO-76	VA-388	VCA-1065	NS ⁴³⁷
4 cyl 2.2L (D) FI	VO-76	VA-217	VCA-1065	NS ⁴³⁷
4 cyl 2.4L (P) FI	VO-76	VA-217	VCA-1065	NS ⁴³⁷

Impala

V6 3.5L (N) FI	VO-108	VA-200	VCA-1002	NS ⁴³⁷
V6 3.5L (K) FI (Flex Fuel)	VO-108	VA-200	VCA-1002	NS ⁴³⁷
V6 3.9L (3) FI (Flex Fuel)	VO-108	VA-200	VCA-1002	NS ⁴³⁷
V8 5.3L (C) FI	VO-88	VA-200	VCA-1002	NS ⁴³⁷

Malibu

4 cyl 2.4L (5) FI (Hybrid)	VO-76	VA-176		NS ⁴³⁷
4 cyl. 2.4L (B) FI	VO-76	VA-176		NS ⁴³⁷
V6 3.6L (7) FI	VO-88	VA-176		NS ⁴³⁷

Malibu Classic

4 cyl. 2.2L (F) FI	VO-76	VA-109		NS ⁴³⁷
V6 3.5L (N) FI	VO-108	VA-269		NS ⁴³⁷

Optra (Canada/Mexico)

4 cyl. 2.0L FI	VO-16	VA-340	VCA-1155	
----------------	-------	--------	----------	--

Silverado Pickup

V6 4.3L (X) FI	VO-16	VA-259		NS ⁴³⁷
V8 4.8L (C) FI	VO-88	VA-259		NS ⁴³⁷
V8 5.3L FI	VO-88	VA-259		NS ⁴³⁷
V8 6.0L (Y) FI	VO-88	VA-259		NS ⁴³⁷
V8 6.0L (K) FI	VO-88	VA-259		NS ⁴³⁷
V8 6.6L (6) Diesel Turbo	VO-75	VA-218		

Suburban, Tahoe

V8 4.8L (C) FI	VO-88	VA-259		NS ⁴³⁷
V8 5.3L (J) FI	VO-88	VA-259		NS ⁴³⁷
V8 5.3L (3,0) FI (Flex Fuel)	VO-88	VA-259		NS ⁴³⁷
V8 6.0L FI	VO-88	VA-259		NS ⁴³⁷
V8 6.0L (5) FI (Hybrid)	VO-88	VA-259		NS ⁴³⁷
V8 6.2L (8) FI	VO-88	VA-259		NS ⁴³⁷

Trailblazer

6 cyl. 4.2L (S) FI	VO-108	VA-161		NS ⁴³⁷
V8 5.3L (M) FI	VO-88	VA-161		NS ⁴³⁷
V8 6.0L (H) FI	VO-88	VA-161		NS ⁴³⁷

Uplander

V6 3.9L (1) FI	VO-108	VA-109	VCA-1164	NS ⁴³⁷
V6 3.9L (W) FI (Flex Fuel)	VO-108	VA-109	VCA-1164	NS ⁴³⁷

2007

Avalanche

V8 5.3L (J) FI	VO-88	VA-259		NS ⁴³⁷
V8 5.3L (3,0) FI (Flex Fuel)	VO-88	VA-259		NS ⁴³⁷
V8 6.0L (Y) FI	VO-88	VA-259		NS ⁴³⁷

Aveo

4 cyl. 1.6L FI	VO-16	VA-188	VCA-1146	
----------------	-------	--------	----------	--

Cobalt

4 cyl. 2.0L (P) FI (S.C.)	VO-76		VCA-1065	
4 cyl. 2.2L (F) FI	VO-76	VA-203	VCA-1065	
4 cyl. 2.4L (B) FI	VO-76	VA-203	VCA-1065	

Colorado

4 cyl. 2.9L (9) FI	VO-58	VA-181		NS ⁴³⁷
5 cyl. 3.7L (E) FI	VO-108	VA-181		NS ⁴³⁷

Se reporter à table de matière pour les notes en bas de page en français. Utilize el contenido para ver notas a pie.

NS - Non-Serviceable / Non réparable / No repairable LF - Life-Time Filter / Filtro para toda la vida / Filtre à vie

⁴³⁷ Requires replacement of the complete fuel pump/fuel filter module.



CHEVROLET (cont'd)

	Oil	Air	Cabin*	Fuel
2007				
Corvette				
V8 6.0L (U) FI	VO-88	VA-109 ¹¹²		NS ⁴³⁷
V8 7.0L (E) FI	VO-152			NS ⁴³⁷
Equinox				
V6 3.4L (F) FI	VO-16	VA-176	VCA-1030	NS ⁴³⁷
Express Van				
V6 4.3L (X) FI	VO-16	VA-169		NS ⁴³⁷
V8 4.8L (V) FI	VO-88	VA-169		NS ⁴³⁷
V8 5.3L (Z) (Flex Fuel)	VO-88	VA-169		NS ⁴³⁷
V8 5.3L (T) FI	VO-88	VA-169		NS ⁴³⁷
V8 6.0L (U) FI	VO-88	VA-169		NS ⁴³⁷
V8 6.6L (2,6) Diesel Turbo	VO-75	VA-381		
HHR				
4 cyl 2.2L (D) FI	VO-76	VA-217	VCA-1065	NS ⁴³⁷
4 cyl 2.4L (P) FI	VO-76	VA-217	VCA-1065	NS ⁴³⁷
Impala				
V6 3.5L (I) FI	VO-108	VA-200	VCA-1002	NS ⁴³⁷
V6 3.5L (K) FI (Flex Fuel)	VO-108	VA-200	VCA-1002	NS ⁴³⁷
V6 3.9L (R) FI	VO-108	VA-200	VCA-1002	NS ⁴³⁷
V8 5.3L (C) FI	VO-88	VA-200	VCA-1002	NS ⁴³⁷
Malibu				
4 cyl 2.2L (F) FI	VO-76	VA-109		NS ⁴³⁷
V6 3.5L (N) FI	VO-108	VA-269		NS ⁴³⁷
V6 3.9L (I) FI	VO-108	VA-269		NS ⁴³⁷
Monte Carlo				
V6 3.5L (K,N) FI	VO-108	VA-200	VCA-1002	NS ⁴³⁷
V6 3.9L (R) FI	VO-108	VA-200	VCA-1002	NS ⁴³⁷
V8 5.3L (C) FI	VO-88	VA-200	VCA-1002	NS ⁴³⁷
Optra (Canada/Mexico)				
4 cyl 2.0L FI	VO-16	VA-340	VCA-1155	
Silverado Classic Pickup				
V6 4.3L (X) FI	VO-16	VA-259		NS ⁴³⁷
V8 4.8L (V) FI	VO-88	VA-259		NS ⁴³⁷
V8 5.3L (Z) (Flex Fuel)	VO-88	VA-259		NS ⁴³⁷
V8 5.3L (B,T) FI	VO-88	VA-259		NS ⁴³⁷
V8 5.3L (T) FI (Hybrid)	VO-88	VA-259		NS ⁴³⁷
V8 6.0L (N) FI	VO-88	VA-259		NS ⁴³⁷
V8 6.0L (U) FI	VO-88	VA-259		NS ⁴³⁷
V8 6.6L (D) Diesel Turbo	VO-75	VA-218		
V8 8.1L (G) FI	VO-65	VA-259		NS ⁴³⁷
Silverado Pickup				
V6 4.3L (X) FI	VO-16	VA-259		NS ⁴³⁷
V8 4.8L (C) FI	VO-88	VA-259		NS ⁴³⁷
V8 5.3L (0,3,J) FI	VO-88	VA-259		NS ⁴³⁷
V8 6.0L (K,Y) FI	VO-88	VA-259		NS ⁴³⁷
V8 6.6L (6) Diesel Turbo	VO-75	VA-218		
Suburban, Tahoe				
V8 4.8L (C) FI	VO-88	VA-259		NS ⁴³⁷
V8 5.3L (J) FI	VO-88	VA-259		NS ⁴³⁷
V8 5.3L (3,0) FI (Flex Fuel)	VO-88	VA-259		NS ⁴³⁷
V8 6.0L (K) FI	VO-88	VA-259		NS ⁴³⁷
V8 6.0L (Y) FI	VO-88	VA-259		NS ⁴³⁷

Se reporter à table de matière pour les notes en bas de page en français. Utilize el contenido para ver notas a pie.

NS - Non-Serviceable / Non réparable / No repairable LF - Life-Time Filter / Filtro para toda la vida / Filtre à vie

¹¹² Requires two (2). ⁴³⁷ Requires replacement of the complete fuel pump/fuel filter module.



CHEVROLET (cont'd)

2007

Trailblazer

6 cyl. 4.2L (S) FI	VO-108	VA-161		NS ⁴³⁷
V8 5.3L (M) FI	VO-88	VA-161		NS ⁴³⁷
V8 6.0L (H) FI	VO-88	VA-161		NS ⁴³⁷

Uplander

V6 3.9L (1) FI	VO-108	VA-109	VCA-1164	NS ⁴³⁷
V6 3.9L (W) FI (Flex Fuel)	VO-108	VA-109	VCA-1164	NS ⁴³⁷

2006

Avalanche

V8 5.3L (Z) (Flex Fuel)	VO-58	VA-259		NS ⁴³⁷
V8 5.3L (T) FI	VO-58	VA-259		NS ⁴³⁷
V8 8.1L (G) FI	VO-65	VA-259		NS ⁴³⁷

Aveo

4 cyl. 1.6L FI	VO-16	VA-188	VCA-1146	
----------------	-------	--------	----------	--

Cobalt

4 cyl. 2.0L (P) FI (S.C.)	VO-76		VCA-1065	
4 cyl. 2.2L (F) FI	VO-76	VA-203	VCA-1065	
4 cyl. 2.4L (B) FI	VO-76	VA-203	VCA-1065	

Colorado

4 cyl. 2.8L (8) FI	VO-58	VA-181		NS ⁴³⁷
5 cyl. 3.5L (6) FI	VO-108	VA-181		NS ⁴³⁷

Corvette

V8 6.0L (U) FI	VO-58	VA-109 ¹¹²		NS ⁴³⁷
V8 7.0L (E) FI	VO-152			NS ⁴³⁷

Epica (Canada)

6 cyl. 2.5L (L) FI	VO-52	VA-386		
--------------------	-------	--------	--	--

Equinox

V6 3.4L (F) FI	VO-16	VA-176	VCA-1030	NS ⁴³⁷
----------------	-------	--------	----------	-------------------

Express Van

V6 4.3L (X) FI	VO-16	VA-169		NS ⁴³⁷
V8 4.8L (V) FI	VO-58	VA-169		NS ⁴³⁷
V8 5.3L (T) FI	VO-58	VA-169		NS ⁴³⁷
V8 6.0L (U) FI	VO-58	VA-169		NS ⁴³⁷
V8 6.6L (2) Diesel Turbo	VO-75	VA-381		

HHR

4 cyl 2.2L (D) FI	VO-76	VA-217	VCA-1065	NS ⁴³⁷
4 cyl 2.4L (P) FI	VO-76	VA-217	VCA-1065	NS ⁴³⁷

Impala

V6 3.5L (1) FI	VO-108	VA-200	VCA-1002	NS ⁴³⁷
V6 3.5L (K) FI (Flex Fuel)	VO-108	VA-200	VCA-1002	NS ⁴³⁷
V6 3.9L (1)	VO-108	VA-200	VCA-1002	NS ⁴³⁷
V8 5.3L (C) FI	VO-58	VA-200	VCA-1002	NS ⁴³⁷

Malibu

4 cyl. 2.2L (F) FI	VO-76	VA-109		NS ⁴³⁷
V6 3.5L (8) FI	VO-16	VA-109		NS ⁴³⁷
V6 3.9L (1) FI	VO-108	VA-269		NS ⁴³⁷

Monte Carlo

V6 3.5L (1) FI	VO-108	VA-200	VCA-1002	NS ⁴³⁷
V6 3.5L (K) FI (Flex Fuel)	VO-108	VA-200	VCA-1002	NS ⁴³⁷
V6 3.9L (1) FI	VO-108	VA-200	VCA-1002	NS ⁴³⁷
V8 5.3L (C) FI	VO-58	VA-200	VCA-1002	NS ⁴³⁷

Optra (Canada/Mexico)

4 cyl. 2.0L FI	VO-16	VA-340	VCA-1155	
----------------	-------	--------	----------	--

Se reporter à table de matière pour les notes en bas de page en français. Utilize el contenido para ver notas a pie.

NS - Non-Serviceable / Non réparable / No reparable LF - Life-Time Filter / Filtro para toda la vida / Filtre à vie

¹¹² Requires two (2). ⁴³⁷ Requires replacement of the complete fuel pump/fuel filter module.



CHEVROLET (cont'd)

	Oil	Air	Cabin*	Fuel
2006				
Silverado Pickup				
V6 4.3L (X) FI	VO-16	VA-259		NS ⁴³⁷
V8 4.8L (V) FI	VO-58	VA-259		NS ⁴³⁷
V8 5.3L (B,T,Z) FI	VO-58	VA-259		NS ⁴³⁷
V8 6.0L (N,U) FI	VO-58	VA-259		NS ⁴³⁷
V8 6.6L (2,D) Diesel Turbo	VO-75	VA-218		
V8 8.1L (G) FI	VO-65	VA-259		NS ⁴³⁷
SSR				
V8 6.0L FI	VO-58			NS ⁴³⁷
Suburban, Tahoe				
V8 4.8L (V) FI	VO-58	VA-259		NS ⁴³⁷
V8 5.3L (T) FI	VO-58	VA-259		NS ⁴³⁷
V8 5.3L (Z) FI (Flex Fuel)	VO-58	VA-259		NS ⁴³⁷
V8 6.0L (U) FI	VO-58	VA-259		NS ⁴³⁷
V8 8.1L (G) FI	VO-65	VA-259		NS ⁴³⁷
Trailblazer				
6 cyl. 4.2L (S) FI	VO-108	VA-161		NS ⁴³⁷
V8 5.3L (M) FI	VO-58	VA-161		NS ⁴³⁷
V8 6.0L (H)	VO-58	VA-161		NS ⁴³⁷
Uplander				
V6 3.5L (L) FI	VO-16	VA-109	VCA-1164	NS ⁴³⁷
V6 3.9L (1) FI	VO-108	VA-109	VCA-1164	NS ⁴³⁷
2005				
Astro Van				
V6 4.3L (X) FI	VO-16	VA-108		VG-14
Avalanche				
V8 5.3L (T) FI	VO-58	VA-259		NS ⁴³⁷
V8 5.3L (Z) FI (Flex Fuel)	VO-58	VA-259		NS ⁴³⁷
V8 8.1L (G) FI	VO-65	VA-259		NS ⁴³⁷
Aveo				
4 cyl. 1.6L FI	VO-16	VA-188	VCA-1146	
Blazer				
V6 4.3L (X) FI	VO-16 ^{X161} VO-55 ^{Z161}	VA-108		
Cavalier				
4 cyl. 2.2L (F) FI	VO-76	VA-65		VG-33
Cobalt				
4 cyl. 2.0L (P) FI (S.C.)	VO-76		VCA-1065	
4 cyl. 2.2L (F) FI	VO-76	VA-203	VCA-1065	
Colorado				
4 cyl. 2.8L (8) FI	VO-58	VA-181		VG-30
5 cyl. 3.5L (6) FI	VO-108	VA-181		VG-30
Corvette				
V8 6.0L (U) FI	VO-58	VA-109 ¹¹²		NS ⁴³⁷
Epica (Canada)				
6 cyl. 2.5L (L) FI	VO-52	VA-386		
Equinox				
V6 3.4L (F) FI	VO-16	VA-176	VCA-1030	NS ⁴³⁷
Express Van				
V6 4.3L (X) FI	VO-16	VA-169		NS ⁴³⁷
V8 4.8L (V) FI	VO-58	VA-169		NS ⁴³⁷
V8 5.3L (T) FI	VO-58	VA-169		NS ⁴³⁷
V8 6.0L (U) FI	VO-58	VA-169		NS ⁴³⁷

Se reporter à table de matière pour les notes en bas de page en français. Utilize el contenido para ver notas a pie.

NS - Non-Serviceable / Non réparable / No reparable LF - Life-Time Filter / Filtro para toda la vida / Filtre à vie

¹¹² Requires two (2). ⁴³⁷ Requires replacement of the complete fuel pump/fuel filter module. ^{X161}2WD ^{Z161}4WD



CHEVROLET (cont'd)

2005

Express Van

V8 6.0L (U) FI (CNG)	VO-58	VA-169		NS ⁴³⁷
----------------------	-------	--------	--	-------------------

Impala

V6 3.4L (E) FI	VO-16	VA-78	VCA-1002	VG-33
V6 3.8L (K) FI	VO-16	VA-78	VCA-1002	VG-33
V6 3.8L (1) FI (S.C.)	VO-16	VA-78	VCA-1002	VG-33

Malibu

4 cyl. 2.2L (F) FI	VO-76	VA-109		NS ⁴³⁷
V6 3.5L (8) FI	VO-16	VA-109		NS ⁴³⁷

Malibu Classic

4 cyl. 2.2L (F) FI	VO-76	VA-91		VG-33
--------------------	-------	-------	--	-------

Monte Carlo

V6 3.4L (E) FI	VO-16	VA-78	VCA-1002	VG-33
V6 3.8L (K) FI	VO-16	VA-78	VCA-1002	VG-33
V6 3.8L (1) FI (S.C.)	VO-16	VA-78	VCA-1002	VG-33

Optra (Canada/Mexico)

4 cyl. 2.0L FI	VO-16	VA-340	VCA-1155	
----------------	-------	--------	----------	--

Silverado Pickup

V6 4.3L (X) FI	VO-16	VA-259		NS ⁴³⁷
V8 4.8L (V) FI	VO-58	VA-259		NS ⁴³⁷
V8 5.3L (B,T,Z) FI	VO-58	VA-259		NS ⁴³⁷
V8 6.0L FI (CNG)	VO-58	VA-259		NS ⁴³⁷
V8 6.0L FI (Gas)	VO-58	VA-259		NS ⁴³⁷
V8 6.6L (2) Diesel Turbo	VO-75	VA-271 ⁸⁹⁷		
V8 8.1L (G) FI	VO-65	VA-259		NS ⁴³⁷

SSR

V8 6.0L FI	VO-58			NS ⁴³⁷
------------	-------	--	--	-------------------

Suburban, Tahoe

V8 4.8L (V) FI	VO-58	VA-259		NS ⁴³⁷
V8 5.3L (T) FI	VO-58	VA-259		NS ⁴³⁷
V8 5.3L (Z) FI (Flex Fuel)	VO-58	VA-259		NS ⁴³⁷
V8 6.0L (U) FI	VO-58	VA-259		NS ⁴³⁷
V8 8.1L (G) FI	VO-65	VA-259		NS ⁴³⁷

Trailblazer

6 cyl. 4.2L (S) FI	VO-108	VA-161		NS ⁴³⁷
V8 5.3L (M) FI	VO-58	VA-161		NS ⁴³⁷

Uplander

V6 3.5L (L) FI	VO-16	VA-109	VCA-1164	NS ⁴³⁷
----------------	-------	--------	----------	-------------------

Venture

V6 3.4L (E) FI	VO-16	VA-109	VCA-1164	
----------------	-------	--------	----------	--

2004

Astro Van

V6 4.3L (X) FI	VO-16	VA-108		VG-14
----------------	-------	--------	--	-------

Avalanche

V8 5.3L (T) FI	VO-58	VA-259	VCA-1074 ^{X628} VCA-1169 ^{Z628}	NS ⁴³⁷
V8 8.1L (G) FI	VO-65	VA-259	VCA-1074 ^{X628} VCA-1169 ^{Z628}	NS ⁴³⁷

Aveo

4 cyl. 1.6L FI	VO-16	VA-188	VCA-1146	
----------------	-------	--------	----------	--

Se reporter à table de matière pour les notes en bas de page en français. Utilize el contenido para ver notas a pie.

NS - Non-Serviceable / Non réparable / No reparable LF - Life-Time Filter / Filtro para toda la vida / Filtre à vie

⁴³⁷ Requires replacement of the complete fuel pump/fuel filter module. ⁸⁹⁷ Heavy Duty ^{X628}Dust and odor. ^{Z628}Dust filter.



CHEVROLET (cont'd)

	Oil	Air	Cabin*	Fuel
2004				
Blazer				
V6 4.3L (X) FI	VO-16 ^{X161} VO-55 ^{Z161}	VA-108		
Cavalier				
4 cyl. 2.2L (F) FI	VO-76	VA-65		VG-33
4 cyl. 2.2L (6) FI (Bi-Fuel)(CNG)	VO-76	VA-65		VG-33
Colorado				
4 cyl. 2.8L (8) FI	VO-58	VA-181		VG-30
5 cyl. 3.5L (6) FI	VO-108	VA-181		VG-30
Corvette				
V8 5.7L (G,S) FI	VO-58	VFAP-917		
Epica (Canada)				
6 cyl. 2.5L (L) FI	VO-52	VA-386		
Express Van				
V6 4.3L (X) FI	VO-16	VA-169		VG-14 ^{X574} VG-33 ^{Z574}
V8 4.8L (V) FI	VO-58	VA-169		NS ⁴³⁷
V8 5.3L (T) FI	VO-58	VA-169		NS ⁴³⁷
V8 6.0L (U) FI	VO-58	VA-169		NS ⁴³⁷
V8 6.0L (U) FI (CNG)	VO-58	VA-169		NS ⁴³⁷
Impala				
V6 3.4L (E) FI	VO-16	VA-78	VCA-1002	VG-33
V6 3.8L (K) FI	VO-16	VA-78	VCA-1002	VG-33
V6 3.8L (1) FI (S.C.)	VO-16	VA-78	VCA-1002	VG-33
Malibu				
4 cyl. 2.2L (F) FI	VO-76	VA-109		NS ⁴³⁷
V6 3.5L (8) FI	VO-16	VA-109		NS ⁴³⁷
Malibu Classic				
4 cyl. 2.2L (F) FI	VO-76	VA-91		VG-33
Monte Carlo				
V6 3.4L (E) FI	VO-16	VA-78	VCA-1002	VG-33
V6 3.8L (K) FI	VO-16	VA-78	VCA-1002	VG-33
V6 3.8L (1) FI (S.C.)	VO-16	VA-78	VCA-1002	VG-33
Optra (Canada/Mexico)				
4 cyl. 2.0L FI	VO-16	VA-340	VCA-1155	
S10				
V6 4.3L (X) FI	VO-55	VA-108		
Silverado Pickup				
V6 4.3L (X) FI	VO-16	VA-259	VCA-1074 ^{X111} VCA-1169 ^{Z111}	VG-14
V8 4.8L (V) FI	VO-58	VA-259	VCA-1074 ^{X111} VCA-1169 ^{Z111}	NS ⁴³⁷
V8 5.3L (Z) (Flex Fuel)	VO-58	VA-259	VCA-1074 ^{X111} VCA-1169 ^{Z111}	
V8 5.3L (T) FI	VO-58	VA-259	VCA-1074 ^{X111} VCA-1169 ^{Z111}	NS ⁴³⁷
V8 6.0L FI (CNG)	VO-58	VA-259	VCA-1074 ^{X111} VCA-1169 ^{Z111}	NS ⁴³⁷
V8 6.0L FI (Gas)	VO-58	VA-259	VCA-1074 ^{X111} VCA-1169 ^{Z111}	NS ⁴³⁷
V8 6.6L (1,2) Diesel Turbo	VO-75	VA-271 ⁸⁹⁷	VCA-1074 ^{X111} VCA-1169 ^{Z111}	

Se reporter à table de matière pour les notes en bas de page en français. Utilize el contenido para ver notas a pie.

NS - Non-Serviceable / Non réparable / No reparable LF - Life-Time Filter / Filtro para toda la vida / Filtre à vie

⁴³⁷ Requires replacement of the complete fuel pump/fuel filter module. ⁸⁹⁷ Heavy Duty ^{X111}Optional Dust and odor filter. Used only if vehicle equipped with cabin air filter housing. ^{X161}2WD ^{X574}Threaded both ends. ^{Z111}Dust filter. ^{Z161}4WD ^{Z574}Threaded one end.



CHEVROLET (cont'd)

2004

Silverado Pickup

V8 8.1L (G) FI	VO-65	VA-259	VCA-1074 ^{X111} VCA-1169 ^{Z111}	NS ⁴³⁷
----------------	-------	--------	--	-------------------

SSR

V8 5.3L FI	VO-58			
------------	-------	--	--	--

Suburban, Tahoe

V8 4.8L (V) FI	VO-58	VA-259	VCA-1074 ^{X628} VCA-1169 ^{Z628}	NS ⁴³⁷
V8 5.3L (T) FI	VO-58	VA-259	VCA-1074 ^{X628} VCA-1169 ^{Z628}	NS ⁴³⁷
V8 5.3L (Z) FI (Flex Fuel)	VO-58	VA-259	VCA-1074 ^{X628} VCA-1169 ^{Z628}	
V8 6.0L (U) FI	VO-58	VA-259	VCA-1074 ^{X628} VCA-1169 ^{Z628}	NS ⁴³⁷
V8 8.1L (G) FI	VO-65	VA-259	VCA-1074 ^{X628} VCA-1169 ^{Z628}	NS ⁴³⁷

Tracker

V6 2.5L (4) FI	VO-25	VA-144	VCA-1160	
----------------	-------	--------	----------	--

Trailblazer

6 cyl. 4.2L (S) FI	VO-108	VA-161		
V8 5.3L (P) FI	VO-58	VA-161		

Venture

V6 3.4L (E) FI	VO-16	VA-109	VCA-1164	
----------------	-------	--------	----------	--

2003

Astro Van

V6 4.3L (X) FI	VO-16	VA-108		VG-14
----------------	-------	--------	--	-------

Avalanche

V8 5.3L (T) FI	VO-58	VA-259	VCA-1074 ^{X628} VCA-1169 ^{Z628}	VG-14
V8 8.1L (G) FI	VO-65	VA-259	VCA-1074 ^{X628} VCA-1169 ^{Z628}	VG-14

Blazer, S10 Pickup

4 cyl. 2.2L (H) FI	VO-16	VA-108		
V6 4.3L (X) FI	VO-16 ^{X161} VO-55 ^{Z161}	VA-108		

Cavalier

4 cyl. 2.2L (F) FI	VO-76	VA-65		VG-33
4 cyl. 2.2L (6) FI (Bi-Fuel)(CNG)	VO-76	VA-65		VG-33

Corvette

V8 5.7L (G,S) FI	VO-58	VFAP-917		
------------------	-------	----------	--	--

Express Van

V6 4.3L (X) FI	VO-16	VA-169		VG-14 ^{X574} VG-33 ^{Z574}
V8 4.8L (V) FI	VO-58	VA-169		VG-14 ^{X574} VG-33 ^{Z574}
V8 5.3L (T) FI	VO-58	VA-169		VG-14 ^{X574} VG-33 ^{Z574}
V8 6.0L (U) FI	VO-58	VA-169		VG-14 ^{X574} VG-33 ^{Z574}
V8 6.0L (U) FI (CNG)	VO-58	VA-169		VG-33 ^{Z574}

Impala

V6 3.4L (E) FI	VO-16	VA-78	VCA-1002	VG-33
V6 3.8L (K) FI	VO-16	VA-78	VCA-1002	VG-33

Se reporter à table de matière pour les notes en bas de page en français. Utilize el contenido para ver notas a pie.

NS - Non-Serviceable / Non réparable / No reparable LF - Life-Time Filter / Filtro para toda la vida / Filtre à vie

⁴³⁷ Requires replacement of the complete fuel pump/fuel filter module. ^{X111} Optional Dust and odor filter. Used only if vehicle equipped with cabin air filter housing.

^{X161} 2WD ^{X574} Threaded both ends. ^{X628} Dust and odor. ^{Z111} Dust filter. ^{Z161} 4WD ^{Z574} Threaded one end. ^{Z628} Dust filter.



CHEVROLET (cont'd)

	Oil	Air	Cabin*	Fuel
2003				
Malibu				
V6 3.1L (J) FI	VO-16	VA-91		VG-33
Monte Carlo				
V6 3.4L (E) FI	VO-16	VA-78	VCA-1002	VG-33
V6 3.8L (K) FI	VO-16	VA-78	VCA-1002	VG-33
Silverado Pickup				
V6 4.3L (X) FI	VO-16	VA-259	VCA-1074 ^{X111} VCA-1169 ^{Z111}	VG-14
V8 4.8L (V) FI	VO-58	VA-259	VCA-1074 ^{X111} VCA-1169 ^{Z111}	VG-14
V8 5.3L (Z) (Flex Fuel)	VO-58	VA-259	VCA-1074 ^{X111} VCA-1169 ^{Z111}	
V8 5.3L FI	VO-58	VA-259	VCA-1074 ^{X111} VCA-1169 ^{Z111}	VG-14
V8 6.0L FI	VO-58	VA-259	VCA-1074 ^{X111} VCA-1169 ^{Z111}	VG-14
V8 6.0L FI CNG	VO-58	VA-259	VCA-1074 ^{X111} VCA-1169 ^{Z111}	
V8 6.6L (1) Diesel Turbo	VO-75	VA-271 ⁸⁹⁷	VCA-1074 ^{X111} VCA-1169 ^{Z111}	
V8 8.1L (G) FI	VO-65	VA-259	VCA-1074 ^{X111} VCA-1169 ^{Z111}	VG-14
SSR				
V8 5.3L FI	VO-58			
Suburban, Tahoe				
V8 4.8L (V) FI	VO-58	VA-259	VCA-1074 ^{X628} VCA-1169 ^{Z628}	VG-14
V8 5.3L (T) FI	VO-58	VA-259	VCA-1074 ^{X628} VCA-1169 ^{Z628}	VG-14
V8 5.3L (Z) FI (Flex Fuel)	VO-58	VA-259	VCA-1074 ^{X628} VCA-1169 ^{Z628}	
V8 6.0L (U) FI	VO-58	VA-259	VCA-1074 ^{X628} VCA-1169 ^{Z628}	VG-14
V8 8.1L (G) FI	VO-65	VA-259	VCA-1074 ^{X628} VCA-1169 ^{Z628}	VG-14
Tracker				
4 cyl. 2.0L (C) FI	VO-40	VA-144	VCA-1160	
V6 2.5L (4) FI	VO-25	VA-144	VCA-1160	
Trailblazer				
6 cyl. 4.2L (S) FI	VO-108	VA-161		
V8 5.3L (P) FI	VO-58	VA-161		
Venture				
V6 3.4L (E) FI	VO-16	VA-109	VCA-1164	
2002				
Astro Van				
V6 4.3L (X) FI	VO-16	VA-108		VG-14
Avalanche				
V8 5.3L (T) FI	VO-108	VA-259	VCA-1003	VG-14
V8 8.1L (G) FI	VO-65	VA-259	VCA-1003	VG-14
Blazer, S10 Pickup				
4 cyl. 2.2L (5) FI (Alt. Fuel)	VO-16	VA-108		
V6 4.3L (W) FI	VO-16 ^{X161} VO-55 ^{Z161}	VA-108		

Se reporter à table de matière pour les notes en bas de page en français. Utilize el contenido para ver notas a pie.

NS - Non-Serviceable / Non réparable / No reparable LF - Life-Time Filter / Filtro para toda la vida / Filtre à vie

⁸⁹⁷ Heavy Duty ^{X111}Optional Dust and odor filter. Used only if vehicle equipped with cabin air filter housing. ^{X161}2WD ^{X628}Dust and odor. ^{Z111}Dust filter.

^{Z161}4WD ^{Z628}Dust filter.



CHEVROLET (cont'd)

2002

C & K Series 3500 HD

V8 6.5L (F) Diesel Turbo	VO-56	VA-92		
V8 8.1L (G) FI	VO-65	VA-92		VG-14

Camaro

V6 3.8L (K) FI	VO-16	VFAP-917		VG-33
V8 5.7L (G) FI	VO-58	VFAP-917		VG-33

Cavalier

4 cyl. 2.2L (4) FI	VO-16	VA-65		VG-33
4 cyl. 2.2L (F) FI	VO-76	VA-65		VG-33
4 cyl. 2.4L (T) FI	VO-58	VA-65		VG-33

Corvette

V8 5.7L (G,S) FI	VO-58	VFAP-917		
------------------	-------	----------	--	--

Express Van

V6 4.3L (W) FI	VO-16	VA-169		VG-30
V8 5.0L (M) FI	VO-56	VA-169		VG-30
V8 5.7L (R) FI	VO-56	VA-169		VG-30
V8 5.7L (R) FI (Bi-Fuel)	VO-56	VA-169		
V8 6.5L (F) Diesel Turbo	VO-56	VFAP-917 ^{X385}		
		VA-412 ^{Z385}		
V8 8.1L (G) FI	VO-65	VA-169		VG-30 ⁸⁴

Impala

V6 3.4L (E) FI	VO-16	VA-78	VCA-1002	VG-33
V6 3.8L (K) FI	VO-16	VA-78	VCA-1002	VG-33

Malibu

V6 3.1L (J) FI	VO-16	VA-91		VG-33
----------------	-------	-------	--	-------

Monte Carlo

V6 3.4L (E) FI	VO-16	VA-78	VCA-1002	VG-33
V6 3.8L (K) FI	VO-16	VA-78	VCA-1002	VG-33

Prizm

4 cyl. 1.8L (8) FI	VO-40	VFAP-7892		NS ⁴³⁷
--------------------	-------	-----------	--	-------------------

Silverado Pickup

V6 4.3L (W,X) FI	VO-16	VA-259	VCA-1003	VG-14
V8 4.8L (V) FI	VO-108	VA-259	VCA-1003	VG-14
V8 5.3L (T) FI	VO-108	VA-259	VCA-1003	VG-14
V8 5.3L (Z) FI (Flex Fuel)	VO-108	VA-259	VCA-1003	
V8 6.0L (U) FI (Bi-Fuel)(CNG)	VO-108	VA-259	VCA-1074 ^{X111}	
			VCA-1169 ^{Z111}	
V8 6.0L (U) FI (Gas)	VO-108	VA-259	VCA-1003	VG-14
V8 6.6L (1) Diesel Turbo	VO-75	VA-271 ⁸⁹⁷	VCA-1003	
V8 8.1L (G) FI	VO-65	VA-259	VCA-1003	VG-14

Suburban, Tahoe

V8 4.8L (V) FI	VO-108	VA-259	VCA-1003	VG-14
V8 5.3L (T) FI	VO-108	VA-259	VCA-1003	VG-14
V8 5.3L (Z) FI (Flex Fuel)	VO-108	VA-259	VCA-1003	
V8 6.0L (U) FI	VO-108	VA-259	VCA-1003	VG-14
V8 8.1L (G) FI	VO-65	VA-259	VCA-1003	VG-14

Tracker

4 cyl. 1.6L (6) FI (Canada)	VO-40	VA-144	VCA-1160	
4 cyl. 2.0L (C) FI	VO-40	VA-144	VCA-1160	
V6 2.5L (4) FI	VO-25	VA-144	VCA-1160	

Trailblazer

6 cyl. 4.2L (S) FI	VO-108	VA-161		
--------------------	--------	--------	--	--

Se reporter à table de matière pour les notes en bas de page en français. Utilize el contenido para ver notas a pie.

NS - Non-Serviceable / Non réparable / No reparable LF - Life-Time Filter / Filtro para toda la vida / Filtre à vie

⁸⁴ In-line filter. ⁴³⁷ Requires replacement of the complete fuel pump/fuel filter module. ⁸⁹⁷ Heavy Duty ^{X111} Optional Dust and odor filter. Used only if vehicle equipped with cabin air filter housing. ^{X385} Standard Duty service. ^{Z111} Dust filter. ^{Z385} Heavy Duty service.



CHEVROLET (cont'd)

	Oil	Air	Cabin*	Fuel
2002				
Venture				
V6 3.4L (E) FI	VO-16	VA-109	VCA-1164	
2001				
Astro Van				
V6 4.3L (W) FI	VO-16	VA-108		VG-14
Blazer, S10 Pickup				
4 cyl. 2.2L (5) FI (Alt. Fuel)	VO-16	VA-108		
V6 4.3L (W) FI	VO-16 ^{X161} VO-55 ^{Z161}	VA-108		
C & K Series 3500 HD				
V8 6.5L (F) Diesel Turbo	VO-56	VA-92		
V8 8.1L (G) FI	VO-65	VA-92		VG-14
Camaro				
V6 3.8L (K) FI	VO-16	VFAP-917		VG-33
V8 5.7L (G) FI	VO-58	VFAP-917		VG-33
Cavalier				
4 cyl. 2.2L (4) FI	VO-16	VA-65		VG-33
4 cyl. 2.4L (T) FI	VO-58	VA-65		VG-33
Corvette				
V8 5.7L (G) FI	VO-58	VFAP-917		
V8 5.7L (S) FI	VO-58	VFAP-917		
Express Van				
V6 4.3L (W) FI	VO-16	VA-169		VG-30
V8 5.0L (M) FI	VO-56	VA-169		VG-30
V8 5.7L (R) FI	VO-56	VA-169		VG-30
V8 5.7L (R) FI (CNG)	VO-56	VA-169		
V8 6.5L (F) Diesel Turbo	VO-56	VFAP-917 ^{X385} VA-412 ^{Z385}		
V8 8.1L (G) FI	VO-65	VA-169		VG-30 ⁸⁴
Impala				
V6 3.4L (E) FI	VO-16	VA-78	VCA-1002	VG-33
V6 3.8L (K) FI	VO-16	VA-78	VCA-1002	VG-33
Lumina				
V6 3.1L (J) FI	VO-16	VA-109		VG-33
Malibu				
V6 3.1L (J) FI	VO-16	VA-91		VG-33
Metro				
4 cyl. 1.3L (2) FI	VO-25			NS ⁴³⁷
Monte Carlo				
V6 3.4L (E) FI	VO-16	VA-78	VCA-1002	VG-33
V6 3.8L (K) FI	VO-16	VA-78	VCA-1002	VG-33
Prizm				
4 cyl. 1.8L (8) FI	VO-40	VFAP-7892		NS ⁴³⁷
Silverado Pickup				
V6 4.3L (W) FI	VO-16	VA-259	VCA-1003	VG-14
V8 4.8L (V) FI	VO-108	VA-259	VCA-1003	VG-14
V8 5.3L (T) FI	VO-108	VA-259	VCA-1003	VG-14
V8 6.0L (U) FI	VO-108	VA-259	VCA-1003	VG-14
V8 6.6L (1) Diesel Turbo	VO-75	VA-271 ⁸⁹⁷	VCA-1003	
V8 8.1L (G) FI	VO-65	VA-259	VCA-1003	VG-14
Suburban, Tahoe				
V8 4.8L (V) FI	VO-108	VA-259	VCA-1003	VG-14
V8 5.3L (T) FI	VO-108	VA-259	VCA-1003	VG-14

Se reporter à table de matière pour les notes en bas de page en français. Utilize el contenido para ver notas a pie.

NS - Non-Serviceable / Non réparable / No repairable LF - Life-Time Filter / Filtro para toda la vida / Filtre à vie

⁸⁴ In-line filter. ⁴³⁷ Requires replacement of the complete fuel pump/fuel filter module. ⁸⁹⁷ Heavy Duty ^{X161}2WD ^{X385}Standard Duty service.

^{Z161}4WD ^{Z385}Heavy Duty service.



CHEVROLET (cont'd)

2001

Suburban, Tahoe

V8 6.0L (U) FI	VO-108	VA-259	VCA-1003	VG-14
V8 8.1L (G) FI	VO-65	VA-259	VCA-1003	VG-14

Tracker

4 cyl. 1.6L (6) FI (Canada)	VO-40	VA-144	VCA-1160	
4 cyl. 2.0L (C) FI	VO-40	VA-144	VCA-1160	
V6 2.5L (4) FI	VO-25	VA-144	VCA-1160	

Venture

V6 3.4L (E) FI	VO-16	VA-109	VCA-1164	
----------------	-------	--------	----------	--

2000

Astro Van

V6 4.3L (W) FI	VO-16	VA-108		VG-14
----------------	-------	--------	--	-------

Blazer, S10 Pickup

4 cyl. 2.2L (4) FI	VO-16	VA-108		
4 cyl. 2.2L (5) FI (Alt. Fuel)	VO-16	VA-108		
V6 4.3L (W) FI	VO-16 ^{X161} VO-55 ^{Z161}	VA-108		

C & K Series 3500 HD

V8 6.5L (F) Diesel Turbo	VO-56	VA-92		
V8 7.4L FI	VO-56	VA-92		VG-14

C & K Series Pickup

V8 5.7L (R) FI (2WD)	VO-56	VA-92		VG-14
V8 5.7L (R) FI (4WD)	VO-55	VA-92		VG-14
V8 6.5L (F) Diesel Turbo	VO-56	VA-92		
V8 7.4L (J) FI (2WD)	VO-56 ^{X410} VO-65 ^{Z410}	VA-92		VG-14
V8 7.4L (J) FI (4WD)	VO-65	VA-92		VG-14

Camaro

V6 3.8L (K) FI	VO-16	VFAP-917		VG-33
V8 5.7L (G) FI	VO-58	VFAP-917		VG-33

Cavalier

4 cyl. 2.2L (4) FI	VO-16	VA-65		VG-33
4 cyl. 2.4L (T) FI	VO-58	VA-65		VG-33

Corvette

V8 5.7L (G) FI	VO-58	VFAP-917		
----------------	-------	----------	--	--

Express Van

V6 4.3L (W) FI	VO-16	VFAP-917		VG-30
V8 5.0L (M) FI	VO-56	VFAP-917		VG-30
V8 5.7L (R) FI	VO-56	VFAP-917		VG-30
V8 6.5L (F) Diesel Turbo	VO-56	VFAP-917 ^{X385} VA-412 ^{Z385}		
V8 7.4L (J) FI	VO-56 ^{X410} VO-65 ^{Z410}	VFAP-917		VG-30 ⁸⁴

Impala

V6 3.4L (E) FI	VO-16	VA-78	VCA-1002	VG-33
V6 3.8L (K) FI	VO-16	VA-78	VCA-1002	VG-33

Lumina

V6 3.1L (J) FI	VO-16	VA-109		VG-33
----------------	-------	--------	--	-------

Malibu

V6 3.1L (J) FI	VO-16	VA-91		VG-33
----------------	-------	-------	--	-------

Metro

3 cyl. 1.0L (6) FI	VO-25			NS ⁴³⁷
4 cyl. 1.3L (2) FI	VO-25			NS ⁴³⁷

Se reporter à table de matière pour les notes en bas de page en français. Utilize el contenido para ver notas a pie.

NS - Non-Serviceable / Non réparable / No reparable LF - Life-Time Filter / Filtro para toda la vida / Filtre à vie

⁸⁴ In-line filter. ⁴³⁷ Requires replacement of the complete fuel pump/fuel filter module. ^{X161}2WD ^{X385}Standard Duty service. ^{X410}Long filter.

^{Z161}4WD ^{Z385}Heavy Duty service. ^{Z410}Short filter.



CHEVROLET (cont'd)

	Oil	Air	Cabin*	Fuel
2000				
Monte Carlo				
V6 3.4L (E) FI	VO-16	VA-78	VCA-1002	VG-33
V6 3.8L (K) FI	VO-16	VA-78	VCA-1002	VG-33
Prizm				
4 cyl. 1.8L (8) FI	VO-40	VFAP-7892		NS ⁴³⁷
Silverado Pickup				
V6 4.3L (W) FI	VO-16	VA-259	VCA-1003	VG-14
V8 4.8L (V) FI	VO-108	VA-259	VCA-1003	VG-14
V8 5.3L (T) FI	VO-108	VA-259	VCA-1003	VG-14
V8 6.0L (U) FI	VO-108	VA-259	VCA-1003	VG-14
Suburban, Tahoe				
V8 4.8L (V) FI	VO-108	VA-259	VCA-1003	VG-14
V8 5.3L (T) FI	VO-108	VA-259	VCA-1003	VG-14
V8 5.7L (R) FI	VO-56 ^{X161}			
	VO-55 ^{Z161}	VA-92		VG-14
V8 6.0L (U) FI	VO-108	VA-259	VCA-1003	VG-14
Tracker				
4 cyl. 1.6L (6) FI	VO-25	VA-144	VCA-1160	
4 cyl. 2.0L (C) FI	VO-40	VA-144	VCA-1160	
Venture				
V6 3.4L (E) FI	VO-16	VA-109	VCA-1021	
1999				
Astro Van				
V6 4.3L (W) FI	VO-55	VA-108		VG-14
Blazer, S10 Pickup				
4 cyl. 2.2L (4) FI	VO-16	VA-108		
V6 4.3L (W,X) FI	VO-55	VA-108		
C & K Series 3500 HD				
V8 6.5L (F) Diesel Turbo	VO-56	VA-92		
V8 7.4L FI	VO-56	VA-92		VG-14
C & K Series Pickup				
V8 5.0L (M) FI (2WD)	VO-56	VA-92		VG-14
V8 5.0L (M) FI (4WD)	VO-55	VA-92		VG-14
V8 5.7L (R) FI (2WD)	VO-56	VA-92		VG-14
V8 5.7L (R) FI (4WD)	VO-55	VA-92		VG-14
V8 6.5L (F,S) Diesel Turbo	VO-56	VA-92		
V8 7.4L (J) FI (2WD)	VO-56 ^{X410}			
	VO-65 ^{Z410}	VA-92		VG-14
V8 7.4L (J) FI (4WD)	VO-65	VA-92		VG-14
Camaro				
V6 3.8L (K) FI	VO-16	VFAP-917		VG-33
V8 5.7L (G) FI	VO-58	VFAP-917		VG-33
Cavalier				
4 cyl. 2.2L (4) FI	VO-16	VA-65		VG-33
4 cyl. 2.4L (T) FI	VO-58	VA-65		VG-33
Corvette				
V8 5.7L (G) FI	VO-58	VFAP-917		
Express Van				
V6 4.3L (W) FI	VO-55	VFAP-917		VG-30
V8 5.0L (M) FI	VO-56	VFAP-917		VG-30
V8 5.7L (R) FI	VO-56	VFAP-917		VG-30
V8 6.5L (F) Diesel Turbo	VO-56	VFAP-917 ^{X385}		
		VA-412 ^{Z385}		

Se reporter à table de matière pour les notes en bas de page en français. Utilize el contenido para ver notas a pie.

NS - Non-Serviceable / Non réparable / No repairable LF - Life-Time Filter / Filtro para toda la vida / Filtre à vie

⁴³⁷ Requires replacement of the complete fuel pump/fuel filter module. ^{X161}2WD ^{X385}Standard Duty service. ^{X410}Long filter. ^{Z161}4WD ^{Z385}Heavy Duty service. ^{Z410}Short filter.



CHEVROLET (cont'd)

1999

Express Van

V8 7.4L (J) FI	VO-56 ^{X410} VO-65 ^{Z410}	VFAP-917		VG-30 ⁸⁴
----------------	--	----------	--	---------------------

Lumina

V6 3.1L (M) FI	VO-16	VA-109		VG-33
V6 3.8L (K) FI	VO-16	VA-109		VG-33

Malibu

4 cyl. 2.4L (T) FI	VO-58	VA-91		VG-33
V6 3.1L (J,M) FI	VO-16	VA-91		VG-33

Metro

3 cyl. 1.0L (6) FI	VO-25			NS ⁴³⁷
4 cyl. 1.3L (2) FI	VO-25			NS ⁴³⁷

Monte Carlo

V6 3.1L (M) FI	VO-16	VA-109	VCA-1002	VG-33
V6 3.8L (K) FI	VO-16	VA-109	VCA-1002	VG-33

Prizm

4 cyl. 1.8L (8) FI	VO-40	VFAP-7892		NS ⁴³⁷
--------------------	-------	-----------	--	-------------------

Silverado Pickup

V6 4.3L (W) FI	VO-55	VA-259	VCA-1003	VG-14
V8 4.8L (V) FI	VO-108	VA-259	VCA-1003	VG-14
V8 5.3L (T) FI	VO-108	VA-259	VCA-1003	VG-14
V8 6.0L (U) FI	VO-108	VA-259	VCA-1003	VG-14

Suburban, Tahoe

V8 5.7L (R) FI (2WD)	VO-56	VA-92		VG-14
V8 5.7L (R) FI (4WD)	VO-55	VA-92		VG-14
V8 6.5L (F,S) Diesel Turbo	VO-56	VA-92		
V8 7.4L (J) FI (2WD)	VO-56	VA-92		VG-14
V8 7.4L (J) FI (4WD)	VO-65	VA-92		VG-14

Tracker

4 cyl. 1.6L (6) FI	VO-25	VA-144	VCA-1160	
4 cyl. 2.0L (C) FI	VO-40	VA-144	VCA-1160	

Van P Series

V6 4.3L (W) FI	VO-16	VA-412		VG-14
V8 5.7L (R) FI	VO-55	VA-412		VG-14
V8 6.5L (F) Diesel Turbo	VO-56	VA-412		
V8 6.5L (Y) FI Diesel	VO-56			
V8 7.4L (B) FI	VO-56	VA-320		VG-14
V8 7.4L (J) FI	VO-56 ^{X410} VO-65 ^{Z410}	VA-412		VG-14

Venture

V6 3.4L (E) FI	VO-16	VA-109	VCA-1021	
----------------	-------	--------	----------	--

1998

Astro Van

V6 4.3L (W) FI	VO-55	VA-108		VG-14
----------------	-------	--------	--	-------

C & K Series Pickup, Tahoe, Suburban

V6 4.3L (W) FI	VO-55	VA-92		VG-14
V8 5.0L (M) FI (2WD)	VO-56	VA-92		VG-14
V8 5.0L (M) FI (4WD)	VO-55	VA-92		VG-14
V8 5.7L (R) FI (2WD)	VO-56	VA-92		VG-14
V8 5.7L (R) FI (4WD)	VO-55	VA-92		VG-14
V8 6.5L Diesel Turbo	VO-56	VA-92		
V8 7.4L (J) FI	VO-56	VA-92		VG-14

Se reporter à table de matière pour les notes en bas de page en français. Utilize el contenido para ver notas a pie.

NS - Non-Serviceable / Non réparable / No reparable LF - Life-Time Filter / Filtro para toda la vida / Filtre à vie

⁸⁴ In-line filter. ⁴³⁷ Requires replacement of the complete fuel pump/fuel filter module. ^{X410}Long filter. ^{Z410}Short filter.



CHEVROLET (cont'd)

	Oil	Air	Cabin*	Fuel
1998				
Camaro				
V6 3.8L (K) FI	VO-16	VFAP-917		VG-33
V8 5.7L (G) FI	VO-58	VFAP-917		VG-33
Cavalier				
4 cyl. 2.2L (4) FI	VO-16	VA-65		VG-33
4 cyl. 2.4L (T) FI	VO-58	VA-65		VG-33
Corvette				
V8 5.7L (G) FI	VO-58	VFAP-917		
Express Van				
V6 4.3L (W) FI	VO-55	VFAP-917		VG-30
V8 5.0L (M) FI	VO-56	VFAP-917		VG-30
V8 5.7L (R) FI	VO-56	VFAP-917		VG-30
V8 6.5L (F) Diesel Turbo	VO-56	VFAP-917 ^{X385} VA-412 ^{Z385}		
V8 7.4L (J) FI	VO-56	VFAP-917		VG-30 ⁸⁴
Lumina				
V6 3.1L (M) FI	VO-16	VA-109		VG-33
V6 3.8L (K) FI	VO-16	VA-109		VG-33
Malibu				
4 cyl. 2.4L (T) FI	VO-58	VA-91		VG-33
V6 3.1L (M) FI	VO-16	VA-91		VG-33
Metro				
3 cyl. 1.0L (6) FI	VO-25			NS ⁴³⁷
4 cyl. 1.3L (2) FI	VO-25			NS ⁴³⁷
Monte Carlo				
V6 3.1L (M) FI	VO-16	VA-109	VCA-1002	VG-33
V6 3.8L (K) FI	VO-16	VA-109	VCA-1002	VG-33
Prizm				
4 cyl. 1.8L (8) FI	VO-40	VFAP-7892		NS ⁴³⁷
S10 Pickup, S10 Blazer				
4 cyl. 2.2L (4) FI	VO-16	VA-108		
V6 4.3L (W,X) FI	VO-55	VA-108		
Tracker				
4 cyl. 1.6L (6) FI	VO-25			
Van P Series				
V6 4.3L (W) FI	VO-55	VA-412		VG-14
V8 5.7L (R) FI	VO-55	VA-412		VG-14
V8 6.5L (F) Diesel Turbo	VO-56	VA-412		
V8 6.5L (Y) FI Diesel	VO-56			
V8 7.4L (J) FI	VO-56	VA-412		VG-14
V8 7.4L (B) FI	VO-56	VA-320		VG-14
Venture				
V6 3.4L (E) FI	VO-16	VA-109	VCA-1021	
1997				
Astro Van				
V6 4.3L (W) FI	VO-55	VA-108		VG-14
C & K Series Pickup, Tahoe, Suburban				
V6 4.3L (W) FI	VO-55	VA-92		VG-14
V8 5.0L (M) FI (2WD)	VO-56	VA-92		VG-14
V8 5.0L (M) FI (4WD)	VO-55	VA-92		VG-14
V8 5.7L (R) FI (2WD)	VO-56	VA-92		VG-14
V8 5.7L (R) FI (4WD)	VO-55	VA-92		VG-14
V8 6.5L Diesel Turbo	VO-56	VA-92		

Se reporter à table de matière pour les notes en bas de page en français. Utilize el contenido para ver notas a pie.

NS - Non-Serviceable / Non réparable / No repairable LF - Life-Time Filter / Filtro para toda la vida / Filtre à vie

⁸⁴ In-line filter. ⁴³⁷ Requires replacement of the complete fuel pump/fuel filter module. ^{X385}Standard Duty service. ^{Z385}Heavy Duty service.



CHEVROLET (cont'd)

1997

C & K Series Pickup, Tahoe, Suburban

V8 7.4L (J) FI	VO-56	VA-92		VG-14
----------------	-------	-------	--	-------

Camaro

V6 3.8L (K) FI	VO-16	VA-108		VG-33
----------------	-------	--------	--	-------

V8 5.7L (P) FI	VO-65	VA-108		VG-33
----------------	-------	--------	--	-------

Cavalier

4 cyl. 2.2L (4) FI	VO-16	VA-65		VG-33
--------------------	-------	-------	--	-------

4 cyl. 2.4L (T) FI	VO-58	VA-65		VG-33
--------------------	-------	-------	--	-------

Corvette

V8 5.7L (G) FI	VO-58	VFAP-917		
----------------	-------	----------	--	--

Express Van

V6 4.3L (W) FI	VO-55	VFAP-917		VG-30
----------------	-------	----------	--	-------

V8 5.0L (M) FI	VO-56	VFAP-917		VG-30
----------------	-------	----------	--	-------

V8 5.7L (R) FI	VO-56	VFAP-917		VG-30
----------------	-------	----------	--	-------

V8 6.5L (F) Diesel Turbo	VO-56	VFAP-917 ^{X385}		
--------------------------	-------	--------------------------	--	--

		VA-412 ^{Z385}		
--	--	------------------------	--	--

V8 7.4L (J) FI	VO-56	VFAP-917		VG-30 ⁸⁴
----------------	-------	----------	--	---------------------

Lumina

V6 3.1L (M) FI	VO-16	VA-109		VG-33
----------------	-------	--------	--	-------

V6 3.4L (X) FI	VO-55	VA-109		VG-33
----------------	-------	--------	--	-------

Malibu

4 cyl. 2.4L (T) FI	VO-58	VA-91		VG-33
--------------------	-------	-------	--	-------

V6 3.1L (M) FI	VO-16	VA-91		VG-33
----------------	-------	-------	--	-------

Monte Carlo

V6 3.1L (M) FI	VO-16	VA-109	VCA-1002	VG-33
----------------	-------	--------	----------	-------

V6 3.4L (X) FI	VO-55	VA-109	VCA-1002	VG-33
----------------	-------	--------	----------	-------

S10 Pickup, S10 Blazer

4 cyl. 2.2L (4) FI	VO-16	VA-108		
--------------------	-------	--------	--	--

V6 4.3L (W,X) FI	VO-55	VA-108		
------------------	-------	--------	--	--

Van P Series

V6 4.3L (W) FI	VO-55	VA-412		VG-14
----------------	-------	--------	--	-------

V8 5.7L (R) FI	VO-55	VA-412		VG-14
----------------	-------	--------	--	-------

V8 6.5L (F) Diesel Turbo	VO-56	VA-412		
--------------------------	-------	--------	--	--

V8 6.5L (Y) FI Diesel	VO-56			
-----------------------	-------	--	--	--

V8 7.4L (N) FI	VO-56	VA-2		VG-14
----------------	-------	------	--	-------

V8 7.4L (J) FI	VO-56	VA-412		VG-14
----------------	-------	--------	--	-------

Venture

V6 3.4L (E) FI	VO-16	VA-109	VCA-1021	
----------------	-------	--------	----------	--

1996

Astro Van

V6 4.3L (W) FI	VO-55	VA-108		VG-14
----------------	-------	--------	--	-------

Beretta

4 cyl. 2.2L (4) FI	VO-16	VA-110		VG-33
--------------------	-------	--------	--	-------

V6 3.1L (M) FI	VO-16	VA-110		VG-33
----------------	-------	--------	--	-------

C & K Series Pickup, Tahoe, Suburban

V6 4.3L (W) FI	VO-55	VA-92		VG-14
----------------	-------	-------	--	-------

V8 5.0L (M) FI (2WD)	VO-56	VA-92		VG-14
----------------------	-------	-------	--	-------

V8 5.0L (M) FI (4WD)	VO-55	VA-92		VG-14
----------------------	-------	-------	--	-------

V8 5.7L (R) FI (2WD)	VO-56	VA-92		VG-14
----------------------	-------	-------	--	-------

V8 5.7L (R) FI (4WD)	VO-55	VA-92		VG-14
----------------------	-------	-------	--	-------

V8 6.5L (F) Diesel Turbo	VO-56	VFAP-917 ^{X385}		
--------------------------	-------	--------------------------	--	--

		VA-412 ^{Z385}		
--	--	------------------------	--	--

Se reporter à table de matière pour les notes en bas de page en français. Utilize el contenido para ver notas a pie.

NS - Non-Serviceable / Non réparable / No reparable LF - Life-Time Filter / Filtro para toda la vida / Filtre à vie

⁸⁴ In-line filter. ^{X385}Standard Duty service. ^{Z385}Heavy Duty service.



CHEVROLET (cont'd)

1996

C & K Series Pickup, Tahoe, Suburban

V8 6.5L (S) Diesel Turbo FI	VO-56	VFAP-917 ^{X385} VA-412 ^{Z385}		
V8 7.4L (J) FI	VO-56	VA-92		VG-14

Camaro

V6 3.8L (K) FI	VO-16	VA-108		VG-33
V8 5.7L (P) FI	VO-65	VA-108		VG-33

Caprice

V8 4.3L (W) FI	VO-55	VA-78		VG-30 ³⁹⁴
V8 5.7L (P) FI	VO-55	VA-78		VG-30 ³⁹⁴

Cavalier

4 cyl. 2.2L (4) FI	VO-16	VA-65		VG-33
4 cyl. 2.4L (T) FI	VO-58	VA-65		VG-33

Corsica

4 cyl. 2.2L (4) FI	VO-16	VA-110		VG-33
V6 3.1L (M) FI	VO-16	VA-110		VG-33

Corvette

V8 5.7L (5,P) FI	VO-55			VG-14
------------------	-------	--	--	-------

Express Van

V6 4.3L (W) FI	VO-55	VFAP-917		VG-30
V8 5.0L (M) FI	VO-56	VFAP-917		VG-30
V8 5.7L (R) FI	VO-56	VFAP-917		VG-30
V8 6.5L (F) Diesel Turbo	VO-56	VFAP-917 ^{X385} VA-412 ^{Z385}		
V8 7.4L (J) FI	VO-56	VFAP-917		VG-30 ⁸⁴

Impala SS

V8 5.7L (P) FI	VO-55	VA-78		VG-30 ³⁹⁴
----------------	-------	-------	--	----------------------

Lumina

V6 3.1L (M) FI	VO-16	VA-109		VG-33
V6 3.4L (X) FI	VO-55	VA-109		VG-33

Lumina APV

V6 3.4L (E) FI	VO-16	VA-65		VG-30
V6 3.8L FI (Mexico)	VO-16	VA-65		VG-30

Monte Carlo

V6 3.1L (M) FI	VO-16	VA-109		VG-33
V6 3.4L (X) FI	VO-55	VA-109		VG-33

S10 Pickup, S10 Blazer

4 cyl. 2.2L (4) FI	VO-16	VA-108		VG-14
V6 4.3L (W,X) FI	VO-55	VA-108		VG-14

Van G Series

V6 4.3L 262 (Z) FI	VO-55	VA-402		VG-14
V8 5.7L (K) FI	VO-56	VA-402		VG-14
V8 6.5L (Y) Diesel	VO-56			
V8 7.4L (N) FI	VO-56	VA-2		VG-14 ⁸⁴

Van P Series

V6 4.3L (W) FI	VO-55	VFAP-917		VG-14
V8 5.7L (R) FI	VO-55	VFAP-917		VG-14
V8 5.7L (K) FI	VO-55	VA-402		VG-14
V8 6.5L (F) Diesel Turbo	VO-56	VFAP-917 ^{X385} VA-412 ^{Z385}		
V8 6.5L (Y) FI Diesel	VO-56			
V8 7.4L (J) FI	VO-56	VFAP-917		VG-14
V8 7.4L (N) FI	VO-56	VA-2		VG-14

Se reporter à table de matière pour les notes en bas de page en français. Utilize el contenido para ver notas a pie.

NS - Non-Serviceable / Non réparable / No reparable LF - Life-Time Filter / Filtro para toda la vida / Filtre à vie

⁸⁴ In-line filter. ³⁹⁴ w/o bracket. ^{X385} Standard Duty service. ^{Z385} Heavy Duty service.



CHEVROLET (cont'd)

1995

Astro Van

V6 4.3L (W) FI	VO-55	VA-108		VG-14
----------------	-------	--------	--	-------

Beretta

4 cyl. 2.2L (4) FI	VO-16	VA-110		VG-33
V6 3.1L (M) FI	VO-16	VA-110		VG-33

C & K Series Pickup, Tahoe, Suburban

V6 4.3L (Z) FI	VO-55	VA-402		VG-14
V8 5.0L (H) FI (2WD)	VO-56	VA-2		VG-14
V8 5.0L (H) FI (4WD)	VO-55	VA-2		VG-14
V8 5.7L (K) FI (2WD)	VO-56	VA-2		VG-14
V8 5.7L (K) FI (4WD)	VO-55	VA-2		VG-14
V8 6.5L Diesel Turbo	VO-56	VFAP-917 ^{X385} VA-412 ^{Z385}		
V8 6.5L (P) FI Diesel	VO-56	VA-45		
V8 7.4L (N) FI	VO-56	VA-2		VG-14

Camaro

V6 3.4L (S) FI	VO-16	VA-108		VG-33
V6 3.8L (K) FI	VO-16	VA-108		VG-33
V8 5.7L (P) FI	VO-65	VA-108		VG-33

Caprice

V8 4.3L (W) FI	VO-55	VA-78		VG-30 ³⁹⁴
V8 5.7L (P) FI	VO-55	VA-78		VG-30 ³⁹⁴

Cavalier

4 cyl. 2.2L (4) FI	VO-16	VA-65		VG-33
4 cyl. 2.3L (D) FI	VO-16	VA-65		VG-33

Corsica

4 cyl. 2.2L (4) FI	VO-16	VA-110		VG-33
V6 3.1L (M) FI	VO-16	VA-110		VG-33

Corvette

V8 5.7L (P) FI	VO-55			VG-14
V8 5.7L (J) FI (ZR1)	VO-35			VG-14

Impala SS

V8 5.7L (P) FI	VO-55	VA-78		VG-30 ³⁹⁴
----------------	-------	-------	--	----------------------

LLV U.S. Postal Service

4 cyl. 2.2L (4) FI	VO-16	VA-85		VG-14
--------------------	-------	-------	--	-------

Lumina

V6 3.1L (M) FI	VO-16	VA-109		VG-33
V6 3.4L (X) FI	VO-55	VA-109		VG-33

Lumina APV

V6 3.1L (D) FI	VO-16	VA-38		VG-30
V6 3.8L FI (Mexico)	VO-16	VA-65		VG-30
V6 3.8L (L) FI	VO-16	VA-65		VG-30

Monte Carlo

V6 3.1L 191 (M) FI	VO-16	VA-109		VG-33
V6 3.4L 207 (X) FI	VO-55	VA-109		VG-33

S10 Pickup, S10 Blazer

4 cyl. 2.2L 133 (4) FI	VO-16	VA-108		VG-14
V6 4.3L 262 (Z) FI	VO-55	VA-38		VG-14
V6 4.3L 262 (W) FI	VO-55	VA-108		VG-14

Van G Series

V6 4.3L 262 (Z) FI	VO-55	VA-402		VG-14
V8 5.0L 305 (H) FI	VO-56	VA-402		VG-14
V8 5.7L 350 (K) FI	VO-56	VA-402		VG-14

Se reporter à table de matière pour les notes en bas de page en français. Utilize el contenido para ver notas a pie.

NS - Non-Serviceable / Non réparable / No reparable LF - Life-Time Filter / Filtro para toda la vida / Filtre à vie

³⁹⁴ w/o bracket. ^{X385} Standard Duty service. ^{Z385} Heavy Duty service.



CHEVROLET (cont'd)

1995

Van G Series

V8 5.7L 350 FI (CNG)	VO-56	VA-402		VG-14
V8 5.7L 350 FI (CNG)	VO-56	VA-402		VG-14
V8 6.5L (Y) FI Diesel	VO-56			
V8 6.5L (P) FI Diesel	VO-56			
V8 7.4L 454 (N) FI	VO-56	VA-2		VG-14 ⁸⁴

Van P Series

V6 4.3L (Z) FI	VO-55	VA-402		VG-14
V8 5.7L (K) FI	VO-56	VA-2 ^{X367}		VG-14
V8 6.5L (F) Diesel Turbo	VO-56	VA-402 ^{Z367}		
V8 6.5L (Y) FI Diesel	VO-56	VFAP-917 ^{X385}		
V8 7.4L (N) FI	VO-56	VA-412 ^{Z385}		
		VA-45		
		VA-2		VG-14

CHRYSLER

2019

300

V6 3.6L	VO-114	VA-293	VCA-1077	NS ⁴³⁷
V8 5.7L	VO-88	VA-293	VCA-1077	NS ⁴³⁷

Pacifica

V6 3.6L	VO-114	VA-461	VCA-1195	NS ⁴³⁷
V6 3.6L Hybrid	VO-114		VCA-1195	NS ⁴³⁷

2018

300

V6 3.6L	VO-114	VA-293	VCA-1077	NS ⁴³⁷
V8 5.7L	VO-88	VA-293	VCA-1077	NS ⁴³⁷

Pacifica

V6 3.6L	VO-114	VA-461	VCA-1195	NS ⁴³⁷
V6 3.6L Hybrid	VO-114		VCA-1195	NS ⁴³⁷

2017

200

4 cyl 2.4L	VO-88	VA-428	VCA-1176	NS ⁴³⁷
V6 3.6L	VO-114	VA-428	VCA-1176	NS ⁴³⁷

300

V6 3.6L	VO-114	VA-293	VCA-1077	NS ⁴³⁷
V8 5.7L	VO-88	VA-293	VCA-1077	NS ⁴³⁷

Pacifica

V6 3.6L	VO-114	VA-461	VCA-1195	NS ⁴³⁷
V6 3.6L Hybrid	VO-114		VCA-1195	NS ⁴³⁷

2016

200

4 cyl 2.4L	VO-88	VA-428	VCA-1176	NS ⁴³⁷
V6 3.6L	VO-114	VA-428	VCA-1176	NS ⁴³⁷

300

V6 3.6L	VO-114	VA-293	VCA-1077	NS ⁴³⁷
V8 5.7L	VO-88	VA-293	VCA-1077	NS ⁴³⁷

Town & Country

V6 3.6L	VO-114	VA-286	VCA-1044	NS ⁴³⁷
---------	--------	--------	----------	-------------------

2015

200

4 cyl 2.4L	VO-88	VA-428	VCA-1176	NS ⁴³⁷
V6 3.6L	VO-114	VA-428	VCA-1176	NS ⁴³⁷

Se reporter à table de matière pour les notes en bas de page en français. Utilize el contenido para ver notas a pie.

NS - Non-Serviceable / Non réparable / No reparable LF - Life-Time Filter / Filtro para toda la vida / Filtre à vie

⁸⁴ In-line filter. ⁴³⁷ Requires replacement of the complete fuel pump/fuel filter module. ^{X367}12 inch O.D. ^{X385}Standard Duty service. ^{Z367}9.75 inch O.D.

^{Z385}Heavy Duty service.



CHRYSLER (cont'd)

2015

300

V6 3.6L	VO-114	VA-293	VCA-1077	NS ⁴³⁷
V8 5.7L	VO-88	VA-293	VCA-1077	NS ⁴³⁷

Town & Country

V6 3.6L	VO-114	VA-286	VCA-1044	NS ⁴³⁷
---------	--------	--------	----------	-------------------

2014

200

4 cyl. 2.4L	VO-88	VA-154	VCA-1069	NS ⁴³⁷
V6 3.6L (Flex Fuel)	VO-114	VA-287	VCA-1069	NS ⁴³⁷

300

V6 3.6L	VO-114	VA-293	VCA-1077	NS ⁴³⁷
V8 5.7L	VO-88	VA-293	VCA-1077	NS ⁴³⁷
V8 6.4L	VO-88	VA-293	VCA-1077	NS ⁴³⁷

Town & Country

V6 3.6L	VO-114	VA-286	VCA-1044	NS ⁴³⁷
---------	--------	--------	----------	-------------------

2013

200

4 cyl. 2.4L	VO-88	VA-154	VCA-1069	NS ⁴³⁷
V6 3.6L (Flex Fuel)	VO-110	VA-287	VCA-1069	NS ⁴³⁷

300

V6 3.6L	VO-110	VA-293	VCA-1077	NS ⁴³⁷
V8 5.7L	VO-88	VA-293	VCA-1077	NS ⁴³⁷
V8 6.4L	VO-88	VA-293	VCA-1077	NS ⁴³⁷

Town & Country

V6 3.6L	VO-110	VA-286	VCA-1044	NS ⁴³⁷
---------	--------	--------	----------	-------------------

2012

200

4 cyl. 2.4L	VO-88	VA-154	VCA-1069	NS ⁴³⁷
V6 3.6L (Flex Fuel)	VO-110	VA-287	VCA-1069	NS ⁴³⁷

300

V6 3.6L	VO-110	VA-293	VCA-1077	NS ⁴³⁷
V8 5.7L	VO-88	VA-293	VCA-1077	NS ⁴³⁷
V8 6.4L	VO-88	VA-293	VCA-1077	NS ⁴³⁷

Town & Country

V6 3.6L	VO-110	VA-286	VCA-1044	NS ⁴³⁷
---------	--------	--------	----------	-------------------

2011

200

4 cyl. 2.4L	VO-88	VA-154	VCA-1069	NS ⁴³⁷
V6 3.6L (Flex Fuel)	VO-110	VA-287	VCA-1069	NS ⁴³⁷

300

V6 3.6L	VO-110	VA-293	VCA-1077	NS ⁴³⁷
V8 5.7L	VO-88	VA-293	VCA-1077	NS ⁴³⁷

Town & Country

V6 3.6L	VO-110	VA-286	VCA-1044	NS ⁴³⁷
---------	--------	--------	----------	-------------------

2010

300

V6 2.7L	VO-88	VA-180	VCA-2033	NS ⁴³⁷
V6 3.5L	VO-88	VA-180	VCA-2033	NS ⁴³⁷
V8 5.7L	VO-88	VA-180	VCA-2033	NS ⁴³⁷
V8 6.1L	VO-88	VA-180	VCA-2033	NS ⁴³⁷

PT Cruiser

4 cyl. 2.4L (9) FI	VO-25	VA-213	VCA-1036 ⁵⁰	NS ⁴³⁷
--------------------	-------	--------	------------------------	-------------------

Se reporter à table de matière pour les notes en bas de page en français. Utilize el contenido para ver notas a pie.

NS - Non-Serviceable / Non réparable / No reparable LF - Life-Time Filter / Filtro para toda la vida / Filtre à vie

⁵⁰ With dealer installed housing. ⁴³⁷ Requires replacement of the complete fuel pump/fuel filter module.



CHRYSLER (cont'd)

	Oil	Air	Cabin*	Fuel
2010				
Sebring				
4 cyl 2.4L (B) FI	VO-88	VA-154	VCA-1069	NS ⁴³⁷
V6 2.7L (D) FI	VO-88	VA-154	VCA-1069	NS ⁴³⁷
V6 3.5L (V) FI	VO-88	VA-154	VCA-1069	NS ⁴³⁷
Town & Country				
V6 3.3L	VO-25	VA-154	VCA-1044	NS ⁴³⁷
V6 3.8L	VO-25	VA-154	VCA-1044	NS ⁴³⁷
V6 4.0L	VO-88	VA-154	VCA-1044	NS ⁴³⁷
2009				
300				
V6 2.7L (D) FI	VO-88	VA-180	VCA-2033	NS ⁴³⁷
V6 3.5L (V) FI	VO-88	VA-180	VCA-2033	NS ⁴³⁷
V8 5.7L (T) FI	VO-88	VA-180	VCA-2033	NS ⁴³⁷
V8 6.1L (W) FI	VO-88	VA-180	VCA-2033	NS ⁴³⁷
Aspen				
V8 4.7L (P) FI (Flex Fuel)	VO-88	VA-179		NS ⁴³⁷
V8 5.7L (T) FI	VO-88	VA-179		NS ⁴³⁷
V8 5.7L (T) FI (Hybrid)	VO-88			NS ⁴³⁷
PT Cruiser				
4 cyl 2.4L (9) FI Non Turbo	VO-25	VA-213	VCA-1036 ⁵⁰	NS ⁴³⁷
4 cyl 2.4L (8) FI Turbo	VO-118	VA-213	VCA-1036 ⁵⁰	NS ⁴³⁷
Sebring				
4 cyl 2.4L (B) FI	VO-88	VA-154	VCA-1069	NS ⁴³⁷
V6 2.7L (D) FI	VO-88	VA-154	VCA-1069	NS ⁴³⁷
V6 3.5L (V) FI	VO-88	VA-154	VCA-1069	NS ⁴³⁷
Town & Country				
V6 3.3L (E) FI (Flex Fuel)	VO-25	VA-154	VCA-1044	NS ⁴³⁷
V6 3.8L (1) FI	VO-25	VA-154	VCA-1044	NS ⁴³⁷
V6 4.0L (X) FI	VO-88	VA-154	VCA-1044	NS ⁴³⁷
2008				
300				
V6 2.7L (R) FI	VO-88 ^{X370} VO-95 ^{1504, Z370}	VA-180	VCA-2033	NS ⁴³⁷
V6 3.5L (G) FI	VO-88 ^{X370} VO-95 ^{1504, Z370}	VA-180	VCA-2033	NS ⁴³⁷
V8 5.7L (H) FI	VO-88 ^{X370} VO-95 ^{1504, Z370}	VA-180	VCA-2033	NS ⁴³⁷
V8 6.1L (W) FI	VO-88 ^{X370} VO-95 ^{1504, Z370}	VA-180	VCA-2033	NS ⁴³⁷
Aspen				
V8 4.7L (N) FI	VO-88 ^{X370} VO-95 ^{1504, Z370}	VA-179		NS ⁴³⁷
V8 4.7L (P) FI (Flex Fuel)	VO-88 ^{X370} VO-95 ^{1504, Z370}	VA-179		NS ⁴³⁷
V8 5.7L (2) FI	VO-88 ^{X370} VO-95 ^{1504, Z370}	VA-179		NS ⁴³⁷
Crossfire				
V6 3.2L (L) FI	VO-69	VA-400 ¹¹²		
Pacifica				
V6 3.8L (L) FI	VO-25	VA-189	VCA-1168	NS ⁴³⁷
V6 4.0L (X) FI	VO-95 ^{X504} VO-25 ^{Z504}	VA-189	VCA-1168	NS ⁴³⁷

Se reporter à table de matière pour les notes en bas de page en français. Utilize el contenido para ver notas a pie.

NS - Non-Serviceable / Non réparable / No reparable LF - Life-Time Filter / Filtro para toda la vida / Filtre à vie

⁵⁰ With dealer installed housing. ¹¹² Requires two (2). ⁴³⁷ Requires replacement of the complete fuel pump/fuel filter module. ¹⁵⁰⁴ Alternate. Primary VO-25

^{X370} with 22 MM THREADED STUD ^{X504} Alternate ^{Z370} with 3/4 INCH THREADED STUD. ^{Z504} Primary



CHRYSLER (cont'd)

2008

PT Cruiser

4 cyl 2.4L (B,X) FI Non Turbo	VO-25	VA-213	VCA-1036 ⁵⁰	NS ⁴³⁷
4 cyl 2.4L (8,E) FI Turbo	VO-118	VA-213	VCA-1036 ⁵⁰	NS ⁴³⁷

Sebring

4 cyl 2.4L (K) FI	VO-88	VA-154	VCA-1069	NS ⁴³⁷
4 cyl 2.4L (J) FI (PZEV)	VO-88	VA-154	VCA-1069	NS ⁴³⁷
V6 2.7L (R) FI	VO-88 ^{X370}			
	VO-95 ^{1504, Z370}	VA-154	VCA-1069	NS ⁴³⁷
V6 3.5L (M) FI	VO-88 ^{X370}			
	VO-95 ^{1504, Z370}	VA-154	VCA-1069	NS ⁴³⁷

Town & Country

V6 3.3L (H) FI	VO-25	VA-154	VCA-1044	NS ⁴³⁷
V6 3.8L (P) FI	VO-25	VA-154	VCA-1044	NS ⁴³⁷
V6 4.0L (X) FI	VO-25	VA-154	VCA-1044	NS ⁴³⁷

2007

300

V6 2.7L (R) FI	VO-95 ^{X504}			
	VO-25 ^{Z504}	VA-180	VCA-2033	NS ⁴³⁷
V6 3.5L (G) FI	VO-95 ^{X504}			
	VO-25 ^{Z504}	VA-180	VCA-2033	NS ⁴³⁷
V8 5.7L (H) FI	VO-95 ^{X504}			
	VO-25 ^{Z504}	VA-180	VCA-2033	NS ⁴³⁷
V8 6.1L (W) FI	VO-95 ^{X504}			
	VO-25 ^{Z504}	VA-180	VCA-2033	NS ⁴³⁷

Aspen

V8 4.7L (N) FI	VO-95 ^{X504}			
	VO-25 ^{Z504}	VA-179		NS ⁴³⁷
V8 4.7L (P) FI (Flex Fuel)	VO-95 ^{X504}			
	VO-25 ^{Z504}	VA-179		NS ⁴³⁷
V8 5.7L (2) FI	VO-95 ^{X504}			
	VO-25 ^{Z504}	VA-179		NS ⁴³⁷

Crossfire

V6 3.2L (L) FI	VO-69	VA-400 ¹¹²		
----------------	-------	-----------------------	--	--

Pacifica

V6 3.8L (L) FI	VO-95 ^{X504}			
	VO-25 ^{Z504}	VA-189	VCA-1168	NS ⁴³⁷
V6 4.0L (X) FI	VO-95 ^{X504}			
	VO-25 ^{Z504}	VA-189	VCA-1168	NS ⁴³⁷

PT Cruiser

4 cyl 2.4L (B,X) FI Non Turbo	VO-25	VA-213	VCA-1036 ⁵⁰	NS ⁴³⁷
4 cyl 2.4L (8,E,G,S) FI Turbo	VO-118	VA-213	VCA-1036 ⁵⁰	NS ⁴³⁷

Sebring

4 cyl 2.4L (K) FI	VO-88	VA-154	VCA-1069	NS ⁴³⁷
V6 2.7L (R) FI	VO-95 ^{X504}			
	VO-25 ^{Z504}	VA-154	VCA-1069	NS ⁴³⁷
V6 3.5L (M) FI	VO-95 ^{X504}			
	VO-25 ^{Z504}	VA-154	VCA-1069	NS

Town & Country

V6 3.3L (R) FI	VO-25	VA-154	VCA-1168	NS ⁴³⁷
V6 3.8L (L) FI	VO-25	VA-154	VCA-1168	NS ⁴³⁷

Se reporter à table de matière pour les notes en bas de page en français. Utilize el contenido para ver notas a pie.

NS - Non-Serviceable / Non réparable / No reparable LF - Life-Time Filter / Filtro para toda la vida / Filtre à vie

⁵⁰ With dealer installed housing. ¹¹² Requires two (2). ⁴³⁷ Requires replacement of the complete fuel pump/fuel filter module. ¹⁵⁰⁴ Alternate. Primary VO-25

^{X370} with 22 MM THREADED STUD ^{X504} Alternate ^{Z370} with 3/4 INCH THREADED STUD. ^{Z504} Primary



CHRYSLER (cont'd)

2006				
300				
V6 2.7L (R) FI	VO-95 ^{X504} VO-25 ^{Z504}	VA-180	VCA-2033	NS ⁴³⁷
V6 3.5L (G) FI	VO-95 ^{X504} VO-25 ^{Z504}	VA-180	VCA-2033	NS ⁴³⁷
V8 5.7L (H) FI	VO-95 ^{X504} VO-25 ^{Z504}	VA-180	VCA-2033	NS ⁴³⁷
V8 6.1L (W) FI	VO-95 ^{X504} VO-25 ^{Z504}	VA-180	VCA-2033	NS ⁴³⁷
Crossfire				
V6 3.2L (L) FI	VO-69	VA-400 ¹¹²		
V6 3.2L (N) FI (S.C.)	VO-69			
Pacifica				
V6 3.5L (4) FI	VO-95 ^{X504} VO-25 ^{Z504}	VA-189	VCA-1168	NS ⁴³⁷
V6 3.8L (L) FI	VO-95 ^{X504} VO-25 ^{Z504}	VA-189	VCA-1168	NS ⁴³⁷
PT Cruiser				
4 cyl. 2.4L (B,X) FI Non Turbo	VO-25	VA-213	VCA-1036 ⁵⁰	NS ⁴³⁷
4 cyl. 2.4L (8,E,G,S) FI Turbo	VO-118	VA-213	VCA-1036 ⁵⁰	NS ⁴³⁷
Sebring Convertible				
4 cyl. 2.4L (X) FI	VO-25	VA-155		NS ⁴³⁷
V6 2.7L (R,T) FI	VO-95 ^{X504} VO-25 ^{Z504}	VA-155		NS ⁴³⁷
Sebring Sedan				
4 cyl. 2.4L (X) FI	VO-25	VA-155		NS ⁴³⁷
V6 2.7L (R,T) FI	VO-95 ^{X504} VO-25 ^{Z504}	VA-155		NS ⁴³⁷
Town & Country				
V6 3.3L (R) FI	VO-95 ^{X504} VO-25 ^{Z504}	VA-154	VCA-1168	NS ⁴³⁷
V6 3.8L (L) FI	VO-95 ^{X504} VO-25 ^{Z504}	VA-154	VCA-1168	NS ⁴³⁷
2005				
300				
V6 2.7L (R) FI	VO-95 ^{X504} VO-25 ^{Z504}	VA-180	VCA-2033	NS ⁴³⁷
V6 3.5L (G) FI	VO-95 ^{X504} VO-25 ^{Z504}	VA-180	VCA-2033	NS ⁴³⁷
V8 5.7L (H) FI	VO-95 ^{X504} VO-25 ^{Z504}	VA-180	VCA-2033	NS ⁴³⁷
V8 6.1L (W) FI	VO-95 ^{X504} VO-25 ^{Z504}	VA-180	VCA-2033	NS ⁴³⁷
Crossfire				
V6 3.2L (L) FI	VO-69	VA-400 ¹¹²		
V6 3.2L (N) FI (S.C.)	VO-69			
Pacifica				
V6 3.5L (4) FI	VO-95 ^{X504} VO-25 ^{Z504}	VA-189	VCA-1168	NS ⁴³⁷
V6 3.8L (L) FI	VO-95 ^{X504} VO-25 ^{Z504}	VA-189	VCA-1168	NS ⁴³⁷
PT Cruiser				
4 cyl. 2.4L (B,X) FI Non Turbo	VO-25	VA-156	VCA-1036 ⁵⁰	NS ⁴³⁷

Se reporter à table de matière pour les notes en bas de page en français. Utilize el contenido para ver notas a pie.

NS - Non-Serviceable / Non réparable / No repairable LF - Life-Time Filter / Filtro para toda la vida / Filtre à vie

⁵⁰ With dealer installed housing. ¹¹² Requires two (2). ⁴³⁷ Requires replacement of the complete fuel pump/fuel filter module. ^{X504}Alternate ^{Z504}Primary



CHRYSLER (cont'd)

2005

PT Cruiser

4 cyl 2.4L (8,E,G,S) FI Turbo	VO-118	VA-156	VCA-1036 ⁵⁰	NS ⁴³⁷
-------------------------------	--------	--------	------------------------	-------------------

Sebring Convertible

4 cyl. 2.4L (X,J) FI DOHC	VO-25	VA-155		NS ⁴³⁷
V6 2.7L (R,T) FI	VO-95 ^{X504} VO-25 ^{Z504}	VA-155		NS ⁴³⁷

Sebring Coupe

4 cyl. 2.4L (G) FI	VO-106	VA-104		NS ⁴³⁷
V6 3.0L (H) FI	VO-106	VA-104		NS ⁴³⁷

Sebring Sedan

4 cyl. 2.4L (J,X) FI	VO-25	VA-155		NS ⁴³⁷
V6 2.7L (R,T) FI	VO-95 ^{X504} VO-25 ^{Z504}	VA-155		NS ⁴³⁷

Town & Country

V6 3.3L (R) FI	VO-95 ^{X504} VO-25 ^{Z504}	VA-154	VCA-1168	NS ⁴³⁷
V6 3.8L (L) FI	VO-95 ^{X504} VO-25 ^{Z504}	VA-154	VCA-1168	NS ⁴³⁷

2004

300M

V6 3.5L (G,K) FI	VO-95 ^{X504} VO-25 ^{Z504}	VA-116		NS ⁴³⁷
------------------	--	--------	--	-------------------

Concorde

V6 2.7L (R) FI	VO-95 ^{X504} VO-25 ^{Z504}	VA-116		NS ⁴³⁷
V6 3.5L (G,M) FI	VO-95 ^{X504} VO-25 ^{Z504}	VA-116		NS ⁴³⁷

Crossfire

V6 3.2L (L) FI	VO-69	VA-400 ¹¹²		
----------------	-------	-----------------------	--	--

Intrepid (Canada)

V6 2.7L (R) FI	VO-95 ^{X504} VO-25 ^{Z504}	VA-116		NS ⁴³⁷
V6 3.5L (G) FI	VO-95 ^{X504} VO-25 ^{Z504}	VA-116		NS ⁴³⁷

Pacifica

V6 3.5L (4) FI	VO-95 ^{X504} VO-25 ^{Z504}	VA-189	VCA-1168	NS ⁴³⁷
----------------	--	--------	----------	-------------------

PT Cruiser

4 cyl 2.4L (B) FI Non Turbo	VO-25	VA-156	VCA-1036 ⁵⁰	NS ⁴³⁷
4 cyl 2.4L (8,G) FI Turbo	VO-118	VA-156	VCA-1036 ⁵⁰	NS ⁴³⁷

Sebring Convertible

4 cyl. 2.4L (X,J) FI	VO-25	VA-155		NS ⁴³⁷
V6 2.7L (R,T) FI	VO-95 ^{X504} VO-25 ^{Z504}	VA-155		NS ⁴³⁷

Sebring Coupe

4 cyl. 2.4L (G) FI	VO-106	VA-104		NS ⁴³⁷
V6 3.0L (H) FI	VO-106	VA-104		NS ⁴³⁷

Sebring Sedan

4 cyl. 2.4L (X,J) FI	VO-25	VA-155		NS ⁴³⁷
V6 2.7L (R,T) FI	VO-95 ^{X504} VO-25 ^{Z504}	VA-155		NS ⁴³⁷

Se reporter à table de matière pour les notes en bas de page en français. Utilize el contenido para ver notas a pie.

NS - Non-Serviceable / Non réparable / No reparable LF - Life-Time Filter / Filtro para toda la vida / Filtre à vie

⁵⁰ With dealer installed housing. ¹¹² Requires two (2). ⁴³⁷ Requires replacement of the complete fuel pump/fuel filter module. ^{X504}Alternate ^{Z504}Primary



CHRYSLER (cont'd)

2004

Town & Country

V6 3.3L (R) FI	VO-95 ^{X504} VO-25 ^{Z504}	VA-154	VCA-1168	
V6 3.8L (L) FI	VO-95 ^{X504} VO-25 ^{Z504}	VA-154	VCA-1168	

2003

300M

V6 3.5L (G,K) FI	VO-95 ^{X504} VO-25 ^{Z504}	VA-116		NS ⁴³⁷
------------------	--	--------	--	-------------------

Concorde

V6 2.7L (R) FI	VO-95 ^{X504} VO-25 ^{Z504}	VA-116		NS ⁴³⁷
V6 3.5L (G,M) FI	VO-95 ^{X504} VO-25 ^{Z504}	VA-116		NS ⁴³⁷

Intrepid (Canada)

V6 2.7L (R) FI	VO-95 ^{X504} VO-25 ^{Z504}	VA-116		NS ⁴³⁷
V6 3.5L (G,M) FI	VO-95 ^{X504} VO-25 ^{Z504}	VA-116		NS ⁴³⁷

PT Cruiser

4 cyl. 2.4L (B) FI Non Turbo	VO-25	VA-156	VCA-1036 ⁵⁰	NS ⁴³⁷
4 cyl. 2.4L (G) FI Turbo	VO-118	VA-156	VCA-1036 ⁵⁰	NS ⁴³⁷

Sebring Convertible

4 cyl. 2.4L (X) FI	VO-25	VA-155		NS ⁴³⁷
V6 2.7L (R,T) FI	VO-95 ^{X504} VO-25 ^{Z504}	VA-155		NS ⁴³⁷

Sebring Coupe

4 cyl. 2.4L (G) FI	VO-106	VA-104		NS ⁴³⁷
V6 3.0L (H) FI	VO-106	VA-104		NS ⁴³⁷

Sebring Sedan

4 cyl. 2.4L (X) FI	VO-25	VA-155		NS ⁴³⁷
V6 2.7L (R,T) FI	VO-95 ^{X504} VO-25 ^{Z504}	VA-155		NS ⁴³⁷

Town & Country

V6 3.3L (R) FI	VO-95 ^{X504} VO-25 ^{Z504}	VA-154	VCA-1168	
V6 3.3L (3) FI (Flex Fuel)	VO-95 ^{X504} VO-25 ^{Z504}	VA-154	VCA-1168	
V6 3.8L (L) FI	VO-95 ^{X504} VO-25 ^{Z504}	VA-154	VCA-1168	

Voyager, Grand Voyager

4 cyl. 2.4L (B) FI	VO-25	VA-154	VCA-1168	
V6 3.3L (3,R) FI	VO-95 ^{X504} VO-25 ^{Z504}	VA-154	VCA-1168	

2002

300M

V6 3.5L (G,K) FI	VO-95 ^{X504} VO-25 ^{Z504}	VA-116		NS ⁴³⁷
------------------	--	--------	--	-------------------

Concorde

V6 2.7L (R) FI	VO-95 ^{X504} VO-25 ^{Z504}	VA-116		NS ⁴³⁷
V6 3.5L (G,M) FI	VO-95 ^{X504} VO-25 ^{Z504}	VA-116		NS ⁴³⁷

Se reporter à table de matière pour les notes en bas de page en français. Utilize el contenido para ver notas a pie.

NS - Non-Serviceable / Non réparable / No repairable LF - Life-Time Filter / Filtro para toda la vida / Filtre à vie

⁵⁰ With dealer installed housing. ⁴³⁷ Requires replacement of the complete fuel pump/fuel filter module. ^{X504}Alternate ^{Z504}Primary



CHRYSLER (cont'd)

2002

Intrepid (Canada)

V6 2.7L (R) FI	VO-95 ^{X504} VO-25 ^{Z504}	VA-116		NS ⁴³⁷
V6 3.5L (G,M) FI	VO-95 ^{X504} VO-25 ^{Z504}	VA-116		NS ⁴³⁷

Neon (Canada)

L4 2.0L 122 (C) FI	VO-25	VA-137		NS ⁴³⁷
--------------------	-------	--------	--	-------------------

Prowler

V6 3.5L (G) FI	VO-95 ^{X504} VO-25 ^{Z504}	VA-69		NS ⁴³⁷
----------------	--	-------	--	-------------------

PT Cruiser

4 cyl. 2.4L (B) FI	VO-25	VA-156	VCA-1036 ⁵⁰	NS ⁴³⁷
--------------------	-------	--------	------------------------	-------------------

Sebring Convertible

4 cyl. 2.4L (X) FI	VO-25	VA-155		NS ⁴³⁷
V6 2.7L (R) FI	VO-95 ^{X504} VO-25 ^{Z504}	VA-155		NS ⁴³⁷

Sebring Coupe

4 cyl. 2.4L (G) FI	VO-106	VA-104		NS ⁴³⁷
V6 3.0L (H) FI	VO-106	VA-104		NS ⁴³⁷

Sebring Sedan

4 cyl. 2.4L (X) FI	VO-25	VA-155		NS ⁴³⁷
V6 2.7L (R) FI	VO-95 ^{X504} VO-25 ^{Z504}	VA-155		NS ⁴³⁷

Town & Country

V6 3.3L (R) FI	VO-95 ^{X504} VO-25 ^{Z504}	VA-154	VCA-1168	
V6 3.3L (3) FI (Flex Fuel)	VO-95 ^{X504} VO-25 ^{Z504}	VA-154	VCA-1168	
V6 3.8L (L) FI	VO-95 ^{X504} VO-25 ^{Z504}	VA-154	VCA-1168	

Voyager, Grand Voyager

4 cyl. 2.4L (B) FI	VO-25	VA-154	VCA-1168	
V6 3.3L (3,R) FI	VO-95 ^{X504} VO-25 ^{Z504}	VA-154	VCA-1168	

2001

300M

V6 3.5L (G) FI	VO-95 ^{X504} VO-25 ^{Z504}	VA-116		NS ⁴³⁷
----------------	--	--------	--	-------------------

Concorde

V6 2.7L (R) FI	VO-95 ^{X504} VO-25 ^{Z504}	VA-116		NS ⁴³⁷
V6 3.2L (J) FI	VO-95 ^{X504} VO-25 ^{Z504}	VA-116		NS ⁴³⁷

Intrepid (Canada)

V6 2.7L (R) FI	VO-95 ^{X504} VO-25 ^{Z504}	VA-116		NS ⁴³⁷
V6 3.2L (J) FI	VO-95 ^{X504} VO-25 ^{Z504}	VA-116		NS ⁴³⁷
V6 3.5L (G) FI	VO-95 ^{X504} VO-25 ^{Z504}	VA-116		NS ⁴³⁷

LHS

V6 3.5L (G) FI	VO-95 ^{X504} VO-25 ^{Z504}	VA-116		NS ⁴³⁷
----------------	--	--------	--	-------------------

Se reporter à table de matière pour les notes en bas de page en français. Utilize el contenido para ver notas a pie.

NS - Non-Serviceable / Non réparable / No repairable LF - Life-Time Filter / Filtro para toda la vida / Filtre à vie

⁵⁰ With dealer installed housing. ⁴³⁷ Requires replacement of the complete fuel pump/fuel filter module. ^{X504}Alternate ^{Z504}Primary



CHRYSLER (cont'd)

2001				
Neon (Canada)				
L4 2.0L 122 (C) FI	VO-25	VA-137		NS ⁴³⁷
Prowler				
V6 3.5L (G) FI	VO-95 ^{X504} VO-25 ^{Z504}	VA-69		NS ⁴³⁷
PT Cruiser				
4 cyl. 2.4L (B) FI	VO-25	VA-156	VCA-1036 ⁵⁰	NS ⁴³⁷
Sebring Convertible				
V6 2.7L (U) FI	VO-95 ^{X504} VO-25 ^{Z504}	VA-155		NS ⁴³⁷
Sebring Coupe				
4 cyl. 2.4L (G) FI	VO-106	VA-104		NS ⁴³⁷
V6 3.0L (H) FI	VO-106	VA-104		NS ⁴³⁷
Sebring Sedan				
4 cyl. 2.4L (X) FI	VO-25	VA-155		NS ⁴³⁷
V6 2.7L (U) FI	VO-95 ^{X504} VO-25 ^{Z504}	VA-155		NS ⁴³⁷
Town & Country				
V6 3.3L (R) FI	VO-95 ^{X504} VO-25 ^{Z504}	VA-154	VCA-1168	
V6 3.3L (3,G) FI (Flex Fuel)	VO-95 ^{X504} VO-25 ^{Z504}	VA-154	VCA-1168	
V6 3.8L (L) FI	VO-95 ^{X504} VO-25 ^{Z504}	VA-154	VCA-1168	
Voyager, Grand Voyager				
4 cyl. 2.4L (B) FI	VO-25	VA-154	VCA-1168	
V6 3.3L (3,R) FI	VO-95 ^{X504} VO-25 ^{Z504}	VA-154	VCA-1168	
2000				
300M				
V6 3.5L (G) FI	VO-95 ^{X504} VO-25 ^{Z504}	VA-116		NS ⁴³⁷
Cirrus				
4 cyl. 2.4L (X) FI	VO-25	VA-112		
V6 2.5L (H) FI	VO-95 ^{X504} VO-25 ^{Z504}	VA-112		
Concorde				
V6 2.7L (R) FI	VO-95 ^{X504} VO-25 ^{Z504}	VA-116		NS ⁴³⁷
V6 3.2L (J) FI	VO-95 ^{X504} VO-25 ^{Z504}	VA-116		NS ⁴³⁷
Grand Voyager				
V6 3.0L (3) FI	VO-95 ^{X504} VO-25 ^{Z504}	VA-69	VCA-1168	
V6 3.3L (R) FI	VO-95 ^{X504} VO-25 ^{Z504}	VA-69	VCA-1168	
V6 3.3L (G) FI (Flex Fuel)	VO-95 ^{X504} VO-25 ^{Z504}	VA-69	VCA-1168	
Intrepid (Canada)				
V6 2.7L (R) FI	VO-95 ^{X504} VO-25 ^{Z504}	VA-116		NS ⁴³⁷
V6 3.2L (J) FI	VO-95 ^{X504} VO-25 ^{Z504}	VA-116		NS ⁴³⁷

Se reporter à table de matière pour les notes en bas de page en français. Utilize el contenido para ver notas a pie.

NS - Non-Serviceable / Non réparable / No repairable LF - Life-Time Filter / Filtro para toda la vida / Filtre à vie

⁵⁰ With dealer installed housing. ⁴³⁷ Requires replacement of the complete fuel pump/fuel filter module. ^{X504}Alternate ^{Z504}Primary



CHRYSLER (cont'd)

2000

Intrepid (Canada)

V6 3.5L (G,V) FI	VO-95 ^{X504} VO-25 ^{Z504}	VA-116		NS ⁴³⁷
------------------	--	--------	--	-------------------

LHS

V6 3.5L (G) FI	VO-95 ^{X504} VO-25 ^{Z504}	VA-116		NS ⁴³⁷
----------------	--	--------	--	-------------------

Neon (Canada)

L4 2.0L 122 (C) FI	VO-25	VA-137		NS ⁴³⁷
--------------------	-------	--------	--	-------------------

Sebring Convertible

V6 2.5L (H) FI	VO-95 ^{X504} VO-25 ^{Z504}	VA-112		
----------------	--	--------	--	--

Sebring Coupe

V6 2.5L (N) FI	VO-95 ^{X504} VO-25 ^{Z504}	VA-104		
----------------	--	--------	--	--

Town & Country

V6 3.3L (R) FI	VO-95 ^{X504} VO-25 ^{Z504}	VA-69		
V6 3.3L (G) FI (Flex Fuel)	VO-95 ^{X504} VO-25 ^{Z504}	VA-69		
V6 3.8L (L) FI	VO-95 ^{X504} VO-25 ^{Z504}	VA-69		

Voyager

4 cyl. 2.4L (B) FI	VO-25	VA-69		
V6 3.0L (3) FI	VO-95 ^{X504} VO-25 ^{Z504}	VA-69		
V6 3.3L (R) FI	VO-95 ^{X504} VO-25 ^{Z504}	VA-69		
V6 3.3L (G) FI (Flex Fuel)	VO-95 ^{X504} VO-25 ^{Z504}	VA-69		

1999

300M

V6 3.5L (G) FI	VO-95 ^{X504} VO-25 ^{Z504}	VA-116		NS ⁴³⁷
----------------	--	--------	--	-------------------

Cirrus

4 cyl. 2.4L (X) FI	VO-95 ^{X504} VO-25 ^{Z504}	VA-112		
V6 2.5L (H) FI	VO-95 ^{X504} VO-25 ^{Z504}	VA-112		

Concorde

V6 2.7L (R) FI	VO-95 ^{X504} VO-25 ^{Z504}	VA-116		NS ⁴³⁷
V6 3.2L (J) FI	VO-95 ^{X504} VO-25 ^{Z504}	VA-116		NS ⁴³⁷

Intrepid (Canada)

V6 2.7L (R) FI	VO-95 ^{X504} VO-25 ^{Z504}	VA-116		NS ⁴³⁷
V6 3.2L (J) FI	VO-95 ^{X504} VO-25 ^{Z504}	VA-116		NS ⁴³⁷

LHS

V6 3.5L (G) FI	VO-95 ^{X504} VO-25 ^{Z504}	VA-116		NS ⁴³⁷
----------------	--	--------	--	-------------------

Se reporter à table de matière pour les notes en bas de page en français. Utilize el contenido para ver notas a pie.

NS - Non-Serviceable / Non réparable / No repairable LF - Life-Time Filter / Filtro para toda la vida / Filtre à vie

⁴³⁷ Requires replacement of the complete fuel pump/fuel filter module. ^{X504}Alternate ^{Z504}Primary



CHRYSLER (cont'd)

1999				
Sebring Convertible				
V6 2.5L (H) FI	VO-95 ^{X504} VO-25 ^{Z504}	VA-112		
Sebring Coupe				
4 cyl. 2.0L (Y) FI	VO-95 ^{X504} VO-25 ^{Z504}	VA-104		
V6 2.5L (N) FI	VO-95 ^{X504} VO-25 ^{Z504}	VA-104		
Town & Country				
V6 3.3L (R) FI	VO-95 ^{X504} VO-25 ^{Z504}	VA-69		
V6 3.3L (G) FI (Flex Fuel)	VO-95 ^{X504} VO-25 ^{Z504}	VA-69		
V6 3.8L (L) FI	VO-95 ^{X504} VO-25 ^{Z504}	VA-69		
1998				
Cirrus				
V6 2.5L (H) FI	VO-95 ^{X504} VO-25 ^{Z504}	VA-112		
Concorde				
V6 2.7L (R) FI	VO-95 ^{X504} VO-25 ^{Z504}	VA-116		NS ⁴³⁷
V6 3.2L (J) FI	VO-95 ^{X504} VO-25 ^{Z504}	VA-116		NS ⁴³⁷
Intrepid (Canada)				
V6 2.7L (R) FI	VO-95 ^{X504} VO-25 ^{Z504}	VA-116		NS ⁴³⁷
V6 3.2L (J) FI	VO-95 ^{X504} VO-25 ^{Z504}	VA-116		NS ⁴³⁷
Sebring Convertible				
4 cyl. 2.4L (X) FI	VO-25	VA-112		
V6 2.5L (H) FI	VO-95 ^{X504} VO-25 ^{Z504}	VA-112		
Sebring Coupe				
4 cyl. 2.0L (Y) FI	VO-95 ^{X504} VO-25 ^{Z504}	VA-104		
V6 2.5L (N) FI	VO-95 ^{X504} VO-25 ^{Z504}	VA-104		
Town & Country				
V6 3.3L (R) FI	VO-95 ^{X504} VO-25 ^{Z504}	VA-69		
V6 3.3L (G) FI (Flex Fuel)	VO-95 ^{X504} VO-25 ^{Z504}	VA-69		
V6 3.8L (L) FI	VO-95 ^{X504} VO-25 ^{Z504}	VA-69		
1997				
Cirrus				
4 cyl. 2.4L (X) FI	VO-25	VA-112		
V6 2.5L (H) FI	VO-95 ^{X504} VO-25 ^{Z504}	VA-112		
Concorde				
V6 3.5L (F) FI	VO-95 ^{X504} VO-25 ^{Z504}	VA-107		

Se reporter à table de matière pour les notes en bas de page en français. Utilize el contenido para ver notas a pie.

NS - Non-Serviceable / Non réparable / No reparable LF - Life-Time Filter / Filtro para toda la vida / Filtre à vie

⁴³⁷ Requires replacement of the complete fuel pump/fuel filter module. ^{X504}Alternate ^{Z504}Primary



CHRYSLER (cont'd)

1997

Intrepid (Canada)

V6 3.3L (T) FI	VO-95 ^{X504} VO-25 ^{Z504}	VA-107		
V6 3.5L (F) FI	VO-95 ^{X504} VO-25 ^{Z504}	VA-107		

LHS

V6 3.5L (F) FI	VO-95 ^{X504} VO-25 ^{Z504}	VA-107		
----------------	--	--------	--	--

Sebring Convertible

4 cyl. 2.4L (X) FI	VO-25	VA-112		
V6 2.5L (H) FI	VO-95 ^{X504} VO-25 ^{Z504}	VA-112		

Sebring Coupe

4 cyl. 2.0L (Y) FI	VO-95 ^{X504} VO-25 ^{Z504}	VA-104		
V6 2.5L (N) FI	VO-95 ^{X504} VO-25 ^{Z504}	VA-104		

Town & Country

V6 3.3L (R) FI	VO-95 ^{X504} VO-25 ^{Z504}	VA-69		
V6 3.8L (L) FI	VO-95 ^{X504} VO-25 ^{Z504}	VA-69		

1996

Cirrus

4 cyl. 2.4L (X) FI	VO-25	VA-112		
V6 2.5L (H) FI	VO-95 ^{X504} VO-25 ^{Z504}	VA-112		

Concorde

V6 3.3L (T) FI	VO-95 ^{X504} VO-25 ^{Z504}	VA-107		
V6 3.5L (F) FI	VO-95 ^{X504} VO-25 ^{Z504}	VA-107		

Intrepid (Canada)

V6 3.3L (T) FI	VO-95 ^{X504} VO-25 ^{Z504}	VA-107		
V6 3.5L (F) FI	VO-95 ^{X504} VO-25 ^{Z504}	VA-107		

LHS

V6 3.5L (F) FI	VO-95 ^{X504} VO-25 ^{Z504}	VA-107		
----------------	--	--------	--	--

New Yorker

V6 3.5L (F) FI	VO-95 ^{X504} VO-25 ^{Z504}	VA-107		
----------------	--	--------	--	--

Sebring Convertible

4 cyl. 2.4L (X) FI	VO-25	VA-112		
V6 2.5L (H) FI	VO-95 ^{X504} VO-25 ^{Z504}	VA-112		

Sebring Coupe

4 cyl. 2.0L (Y) FI	VO-95 ^{X504} VO-25 ^{Z504}	VA-104		
V6 2.5L (N) FI	VO-95 ^{X504} VO-25 ^{Z504}	VA-104		

Se reporter à table de matière pour les notes en bas de page en français. Utilize el contenido para ver notas a pie.

NS - Non-Serviceable / Non réparable / No reparable LF - Life-Time Filter / Filtro para toda la vida / Filtre à vie

^{X504}Alternate ^{Z504}Primary



CHRYSLER (cont'd)

1996

Town & Country

V6 3.3L (R) FI	VO-95 ^{X504} VO-25 ^{Z504}	VA-69		
V6 3.8L (L) FI	VO-95 ^{X504} VO-25 ^{Z504}	VA-69		

1995

Cirrus

4 cyl. 2.4L (X) FI	VO-25	VA-112		
V6 2.5L (H) FI	VO-95 ^{X504} VO-25 ^{Z504}	VA-112		

Concorde

V6 3.3L (T) FI	VO-95 ^{X504} VO-25 ^{Z504}	VA-107		
V6 3.3L (U) FI (Flex Fuel)	VO-95 ^{X504} VO-25 ^{Z504}	VA-107		
V6 3.5L (F) FI	VO-95 ^{X504} VO-25 ^{Z504}	VA-107		

Intrepid (Canada)

V6 3.3L (T) FI	VO-95 ^{X504} VO-25 ^{Z504}	VA-107		
V6 3.3L (U) FI (Flex Fuel)	VO-95 ^{X504} VO-25 ^{Z504}	VA-107		
V6 3.5L (F) FI	VO-95 ^{X504} VO-25 ^{Z504}	VA-107		

LeBaron GTC

V6 3.0L (3) FI	VO-95 ^{X504} VO-25 ^{Z504}	VA-69		
----------------	--	-------	--	--

LHS

V6 3.5L (F) FI	VO-95 ^{X504} VO-25 ^{Z504}	VA-107		
----------------	--	--------	--	--

New Yorker

V6 3.5L (F) FI	VO-95 ^{X504} VO-25 ^{Z504}	VA-107		
----------------	--	--------	--	--

Sebring

4 cyl. 2.0L (Y) FI	VO-95 ^{X504} VO-25 ^{Z504}	VA-104		
V6 2.5L (N) FI	VO-95 ^{X504} VO-25 ^{Z504}	VA-104		

Town & Country

V6 3.8L (L) FI	VO-95 ^{X504} VO-25 ^{Z504}	VA-40		
----------------	--	-------	--	--

DAEWOO

2002

Lanos

4 cyl. 1.5L FI (Canada)	VO-16			
4 cyl. 1.6L FI	VO-16			

Leganza

4 cyl. 2.2L FI	VO-16			
----------------	-------	--	--	--

Nubira

4 cyl. 2.0L FI	VO-16			
----------------	-------	--	--	--

Se reporter à table de matière pour les notes en bas de page en français. Utilize el contenido para ver notas a pie.

NS - Non-Serviceable / Non réparable / No repairable LF - Life-Time Filter / Filtro para toda la vida / Filtre à vie

^{X504}Alternate ^{Z504}Primary



DAEWOO (cont'd)

2001

Lanos

4 cyl. 1.5L FI (Canada)	VO-16			
4 cyl. 1.6L FI	VO-16			

Leganza

4 cyl. 2.2L FI	VO-16			
----------------	-------	--	--	--

Nubira

4 cyl. 2.0L FI	VO-16			
----------------	-------	--	--	--

2000

Lanos

4 cyl. 1.5L FI (Canada)	VO-16			
4 cyl. 1.6L FI	VO-16			

Leganza

4 cyl. 2.2L FI	VO-16			
----------------	-------	--	--	--

Nubira

4 cyl. 2.0L FI	VO-16			
----------------	-------	--	--	--

1999

Lanos

4 cyl. 1.5L FI (Canada)	VO-16			
4 cyl. 1.6L FI	VO-16			

Leganza

4 cyl. 2.2L FI	VO-16			
----------------	-------	--	--	--

Nubira

4 cyl. 2.0L FI	VO-16			
----------------	-------	--	--	--

DODGE (ALSO SEE RAM)

2019

Challenger

V6 3.6L	VO-114	VA-293	VCA-1077	NS ⁴³⁷
V8 5.7L	VO-88	VA-293	VCA-1077	NS ⁴³⁷
V8 6.2L Supercharged	VO-88	VA-293	VCA-1077	NS ⁴³⁷
V8 6.4L	VO-88	VA-293	VCA-1077	NS ⁴³⁷

Charger

V6 3.6L	VO-114	VA-293	VCA-1077	NS ⁴³⁷
V8 5.7L	VO-88	VA-293	VCA-1077	NS ⁴³⁷
V8 6.2L Supercharged	VO-88	VA-293	VCA-1077	NS ⁴³⁷
V8 6.4L	VO-88	VA-293	VCA-1077	NS ⁴³⁷

Durango

V6 3.6L	VO-114	VA-273	VCA-1073	NS ⁴³⁷
V8 5.7L	VO-88	VA-273	VCA-1073	NS ⁴³⁷
V8 6.4L	VO-88	VA-273	VCA-1073	NS ⁴³⁷

Grand Caravan

V6 3.6L	VO-114	VA-286	VCA-1044	NS ⁴³⁷
---------	--------	--------	----------	-------------------

Journey

4 cyl 2.4L	VO-88	VA-245	VCA-1069	NS ⁴³⁷
V6 3.6L	VO-114	VA-287	VCA-1069	NS ⁴³⁷

2018

Challenger

V6 3.6L	VO-114	VA-293	VCA-1077	NS ⁴³⁷
V8 5.7L	VO-88	VA-293	VCA-1077	NS ⁴³⁷
V8 6.2L Supercharged	VO-88	VA-293	VCA-1077	NS ⁴³⁷
V8 6.4L	VO-88	VA-293	VCA-1077	NS ⁴³⁷

Charger

V6 3.6L	VO-114	VA-293	VCA-1077	NS ⁴³⁷
---------	--------	--------	----------	-------------------

Se reporter à table de matière pour les notes en bas de page en français. Utilize el contenido para ver notas a pie.

NS - Non-Serviceable / Non réparable / No repairable LF - Life-Time Filter / Filtro para toda la vida / Filtre à vie

⁴³⁷ Requires replacement of the complete fuel pump/fuel filter module.



DODGE (ALSO SEE RAM) (cont'd)

Model	Oil	Air	Cabin*	Fuel
2018				
Charger				
V8 5.7L	VO-88	VA-293	VCA-1077	NS ⁴³⁷
V8 6.2L Supercharged	VO-88	VA-293	VCA-1077	NS ⁴³⁷
V8 6.4L	VO-88	VA-293	VCA-1077	NS ⁴³⁷
Durango				
V6 3.6L	VO-114	VA-273	VCA-1073	NS ⁴³⁷
V8 5.7L	VO-88	VA-273	VCA-1073	NS ⁴³⁷
V8 6.4L	VO-88	VA-273	VCA-1073	NS ⁴³⁷
Grand Caravan				
V6 3.6L	VO-114	VA-286	VCA-1044	NS ⁴³⁷
Journey				
4 cyl 2.4L	VO-88	VA-245	VCA-1069	NS ⁴³⁷
V6 3.6L	VO-114	VA-287	VCA-1069	NS ⁴³⁷
2017				
Challenger				
V6 3.6L (Flex Fuel)	VO-114	VA-293	VCA-1077	NS ⁴³⁷
V8 5.7L	VO-88	VA-293	VCA-1077	NS ⁴³⁷
V8 6.2L Supercharged	VO-88	VA-293	VCA-1077	NS ⁴³⁷
V8 6.4L	VO-88	VA-293	VCA-1077	NS ⁴³⁷
Charger				
V6 3.6L	VO-114	VA-293	VCA-1077	NS ⁴³⁷
V8 5.7L	VO-88	VA-293	VCA-1077	NS ⁴³⁷
V8 6.2L Supercharged	VO-88	VA-293	VCA-1077	NS ⁴³⁷
V8 6.4L FI	VO-88	VA-293	VCA-1077	NS ⁴³⁷
Durango				
V6 3.6L (G) (Flex Fuel)	VO-114	VA-273	VCA-1073	NS ⁴³⁷
V8 5.7L	VO-88	VA-273	VCA-1073	NS ⁴³⁷
Grand Caravan				
V6 3.6L	VO-114	VA-286	VCA-1044	NS ⁴³⁷
Journey				
4 cyl 2.4L	VO-88	VA-245	VCA-1069	NS ⁴³⁷
V6 3.6L	VO-114	VA-287	VCA-1069	NS ⁴³⁷
Viper				
V10 8.4L	VO-88	VA-330		NS ⁴³⁷
2016				
Challenger				
V6 3.6L (Flex Fuel)	VO-114	VA-293	VCA-1077	NS ⁴³⁷
V8 5.7L	VO-88	VA-293	VCA-1077	NS ⁴³⁷
V8 6.2L Supercharged	VO-88	VA-293	VCA-1077	NS ⁴³⁷
V8 6.4L	VO-88	VA-293	VCA-1077	NS ⁴³⁷
Charger				
V6 3.6L FI	VO-114	VA-293	VCA-1077	NS ⁴³⁷
V8 5.7L FI	VO-88	VA-293	VCA-1077	NS ⁴³⁷
V8 6.2L Supercharged	VO-88	VA-293	VCA-1077	NS ⁴³⁷
V8 6.4L	VO-88	VA-293	VCA-1077	NS ⁴³⁷
Dart				
4 cyl. 1.4L Turbo	VO-116	VA-303	VCA-1037	
4 cyl. 2.0L	VO-88	VA-303	VCA-1037	NS ⁴³⁷
4 cyl. 2.4L	VO-88	VA-303	VCA-1037	NS ⁴³⁷
Durango				
V6 3.6L (Flex Fuel)	VO-114	VA-273	VCA-1073	NS ⁴³⁷
V8 5.7L	VO-88	VA-273	VCA-1073	NS ⁴³⁷

Se reporter à table de matière pour les notes en bas de page en français. Utilize el contenido para ver notas a pie.

NS - Non-Serviceable / Non réparable / No reparable LF - Life-Time Filter / Filtro para toda la vida / Filtre à vie

⁴³⁷ Requires replacement of the complete fuel pump/fuel filter module.



DODGE (ALSO SEE RAM) (cont'd)

2016

Grand Caravan

V6 3.6L	VO-114	VA-286	VCA-1044	NS ⁴³⁷
---------	--------	--------	----------	-------------------

Journey

4 cyl 2.4L	VO-88	VA-245	VCA-1069	NS ⁴³⁷
------------	-------	--------	----------	-------------------

V6 3.6L (Flex Fuel)	VO-114	VA-287	VCA-1069	NS ⁴³⁷
---------------------	--------	--------	----------	-------------------

Viper

V10 8.4L	VO-88	VA-330		NS ⁴³⁷
----------	-------	--------	--	-------------------

2015

Challenger

V6 3.6L (Flex Fuel)	VO-114	VA-293	VCA-1077	NS ⁴³⁷
---------------------	--------	--------	----------	-------------------

V8 5.7L	VO-88	VA-293	VCA-1077	NS ⁴³⁷
---------	-------	--------	----------	-------------------

V8 6.2L Supercharged	VO-88	VA-293	VCA-1077	NS ⁴³⁷
----------------------	-------	--------	----------	-------------------

V8 6.4L	VO-88	VA-293	VCA-1077	NS ⁴³⁷
---------	-------	--------	----------	-------------------

Charger

V6 3.6L	VO-114	VA-293	VCA-1077	NS ⁴³⁷
---------	--------	--------	----------	-------------------

V8 5.7L	VO-88	VA-293	VCA-1077	NS ⁴³⁷
---------	-------	--------	----------	-------------------

V8 6.2L Supercharged	VO-88	VA-293	VCA-1077	NS ⁴³⁷
----------------------	-------	--------	----------	-------------------

V8 6.4L	VO-88	VA-293	VCA-1077	NS ⁴³⁷
---------	-------	--------	----------	-------------------

Dart

4 cyl. 1.4L Turbo	VO-116	VA-303	VCA-1037	
-------------------	--------	--------	----------	--

4 cyl. 2.0L	VO-88	VA-303	VCA-1037	NS ⁴³⁷
-------------	-------	--------	----------	-------------------

4 cyl. 2.4L	VO-88	VA-303	VCA-1037	NS ⁴³⁷
-------------	-------	--------	----------	-------------------

Durango

V6 3.6L (Flex Fuel)	VO-114	VA-273	VCA-1073	NS ⁴³⁷
---------------------	--------	--------	----------	-------------------

V8 5.7L	VO-88	VA-273	VCA-1073	NS ⁴³⁷
---------	-------	--------	----------	-------------------

Grand Caravan

V6 3.6L	VO-114	VA-286	VCA-1044	NS ⁴³⁷
---------	--------	--------	----------	-------------------

Journey

4 cyl 2.4L	VO-88	VA-245	VCA-1069	NS ⁴³⁷
------------	-------	--------	----------	-------------------

V6 3.6L (Flex Fuel)	VO-114	VA-287	VCA-1069	NS ⁴³⁷
---------------------	--------	--------	----------	-------------------

Viper

V10 8.4L	VO-88	VA-330		NS ⁴³⁷
----------	-------	--------	--	-------------------

2014

Avenger

4 cyl 2.4L	VO-88	VA-154	VCA-1069	NS ⁴³⁷
------------	-------	--------	----------	-------------------

V6 3.6L (Flex Fuel)	VO-114	VA-287	VCA-1069	NS ⁴³⁷
---------------------	--------	--------	----------	-------------------

Challenger

V6 3.6L (G) (Flex Fuel)	VO-114	VA-293	VCA-1077	NS ⁴³⁷
-------------------------	--------	--------	----------	-------------------

V8 5.7L	VO-88	VA-293	VCA-1077	NS ⁴³⁷
---------	-------	--------	----------	-------------------

V8 6.4L	VO-88	VA-293	VCA-1077	NS ⁴³⁷
---------	-------	--------	----------	-------------------

Charger

V6 3.6L	VO-114	VA-293	VCA-1077	NS ⁴³⁷
---------	--------	--------	----------	-------------------

V8 5.7L	VO-88	VA-293	VCA-1077	NS ⁴³⁷
---------	-------	--------	----------	-------------------

V8 6.4L	VO-88	VA-293	VCA-1077	NS ⁴³⁷
---------	-------	--------	----------	-------------------

Dart

4 cyl. 1.4L Turbo	VO-116	VA-303	VCA-1037	
-------------------	--------	--------	----------	--

4 cyl. 2.0L	VO-88	VA-303	VCA-1037	NS ⁴³⁷
-------------	-------	--------	----------	-------------------

4 cyl. 2.4L	VO-88	VA-303	VCA-1037	NS ⁴³⁷
-------------	-------	--------	----------	-------------------

Durango

V6 3.6L (Flex Fuel)	VO-114	VA-273	VCA-1073	NS ⁴³⁷
---------------------	--------	--------	----------	-------------------

V8 5.7L	VO-88	VA-273	VCA-1073	NS ⁴³⁷
---------	-------	--------	----------	-------------------

Se reporter à table de matière pour les notes en bas de page en français. Utilize el contenido para ver notas a pie.

NS - Non-Serviceable / Non réparable / No repairable LF - Life-Time Filter / Filtro para toda la vida / Filtre à vie

⁴³⁷ Requires replacement of the complete fuel pump/fuel filter module.



DODGE (ALSO SEE RAM) (cont'd)

	Oil	Air	Cabin*	Fuel
2014				
Grand Caravan				
V6 3.6L	VO-114	VA-286	VCA-1044	NS ⁴³⁷
Journey				
4 cyl 2.4L	VO-88	VA-245	VCA-1069	NS ⁴³⁷
V6 3.6L (Flex Fuel)	VO-114	VA-287	VCA-1069	NS ⁴³⁷
2013				
Avenger				
4 cyl 2.4L	VO-88	VA-154	VCA-1069	NS ⁴³⁷
V6 3.6L (Flex Fuel)	VO-110	VA-287	VCA-1069	NS ⁴³⁷
Challenger				
V6 3.6L (Flex Fuel)	VO-110	VA-293	VCA-1077	NS ⁴³⁷
V8 5.7L	VO-88	VA-293	VCA-1077	NS ⁴³⁷
V8 6.4L	VO-88	VA-293	VCA-1077	NS ⁴³⁷
Charger				
V6 3.6L	VO-110	VA-293	VCA-1077	NS ⁴³⁷
V8 5.7L	VO-88	VA-293	VCA-1077	NS ⁴³⁷
V8 6.4L	VO-88	VA-293	VCA-1077	NS ⁴³⁷
Dart				
4 cyl. 1.4L Turbo	VO-116	VA-303	VCA-1037	
4 cyl. 2.0L	VO-88	VA-303	VCA-1037	NS ⁴³⁷
4 cyl. 2.4L	VO-88	VA-303	VCA-1037	NS ⁴³⁷
Durango				
V6 3.6L (Flex Fuel)	VO-110	VA-273	VCA-1073	NS ⁴³⁷
V8 5.7L	VO-88	VA-273	VCA-1073	NS ⁴³⁷
Grand Caravan				
V6 3.6L	VO-110	VA-286	VCA-1044	NS ⁴³⁷
Journey				
4 cyl 2.4L	VO-88	VA-245	VCA-1069	NS ⁴³⁷
V6 3.6L (Flex Fuel)	VO-110	VA-287	VCA-1069	NS ⁴³⁷
2012				
Avenger				
4 cyl 2.4L	VO-88	VA-154	VCA-1069	NS ⁴³⁷
V6 3.6L (Flex Fuel)	VO-110	VA-287	VCA-1069	NS ⁴³⁷
Caliber				
4 cyl 2.0L (A)	VO-88	VA-290	VCA-1069	NS ⁴³⁷
Challenger				
V6 3.6L (Flex Fuel)	VO-110	VA-293	VCA-1077	NS ⁴³⁷
V8 5.7L	VO-88	VA-293	VCA-1077	NS ⁴³⁷
V8 6.4L	VO-88	VA-293	VCA-1077	NS ⁴³⁷
Charger				
V6 3.6L	VO-110	VA-293	VCA-1077	NS ⁴³⁷
V8 5.7L	VO-88	VA-293	VCA-1077	NS ⁴³⁷
V8 6.4L	VO-88	VA-293	VCA-1077	NS ⁴³⁷
Durango				
V6 3.6L (Flex Fuel)	VO-110	VA-273	VCA-1073	NS ⁴³⁷
V8 5.7L	VO-88	VA-273	VCA-1073	NS ⁴³⁷
Grand Caravan				
V6 3.6L	VO-110	VA-286	VCA-1044	NS ⁴³⁷
Journey				
4 cyl 2.4L	VO-88	VA-245	VCA-1069	NS ⁴³⁷
V6 3.6L (Flex Fuel)	VO-110	VA-287	VCA-1069	NS ⁴³⁷

Se reporter à table de matière pour les notes en bas de page en français. Utilize el contenido para ver notas a pie.

NS - Non-Serviceable / Non réparable / No reparable LF - Life-Time Filter / Filtro para toda la vida / Filtre à vie

⁴³⁷ Requires replacement of the complete fuel pump/fuel filter module.



DODGE (ALSO SEE RAM) (cont'd)

2011

Avenger

4 cyl 2.4L (B)	VO-88	VA-154	VCA-1069	NS ⁴³⁷
V6 3.6L (G) (Flex Fuel)	VO-110	VA-287	VCA-1069	NS ⁴³⁷

Caliber

4 cyl 2.0L (A)	VO-88	VA-290	VCA-1069	NS ⁴³⁷
4 cyl 2.4L (B)	VO-88	VA-290	VCA-1069	NS ⁴³⁷

Challenger

V6 3.6L (Flex Fuel)	VO-110	VA-293	VCA-1077	NS ⁴³⁷
V8 5.7L	VO-88	VA-293	VCA-1077	NS ⁴³⁷
V8 6.4L	VO-88	VA-293	VCA-1077	NS ⁴³⁷

Charger

V6 3.6L	VO-110	VA-293	VCA-1077	NS ⁴³⁷
V8 5.7L	VO-88	VA-293	VCA-1077	NS ⁴³⁷

Durango

V6 3.6L (Flex Fuel)	VO-110	VA-273	VCA-1073	NS ⁴³⁷
V8 5.7L	VO-88	VA-273	VCA-1073	NS ⁴³⁷

Grand Caravan

V6 3.6L	VO-110	VA-286	VCA-1044	NS ⁴³⁷
---------	--------	--------	----------	-------------------

Journey

4 cyl 2.4L	VO-88	VA-245	VCA-1069	NS ⁴³⁷
V6 3.6L (Flex Fuel)	VO-110	VA-287	VCA-1069	NS ⁴³⁷

Nitro

V6 3.7L (K) FI	VO-88	VA-232	VCA-1093	NS ⁴³⁷
V6 4.0L (X) FI	VO-88	VA-232	VCA-1093	NS ⁴³⁷

2010

Avenger

4 cyl 2.4L (B)	VO-88	VA-154	VCA-1069	NS ⁴³⁷
V6 2.7L (D) (Flex Fuel)	VO-88	VA-154	VCA-1069	NS ⁴³⁷
V6 3.5L (V)	VO-88	VA-154	VCA-1069	NS ⁴³⁷

Caliber

4 cyl 2.0L (A)	VO-88	VA-229	VCA-1069	NS ⁴³⁷
4 cyl 2.4L (B)	VO-88	VA-229	VCA-1069	NS ⁴³⁷

Challenger

V6 3.5L (V) FI	VO-88	VA-180	VCA-2033	NS ⁴³⁷
V8 5.7L (T) FI	VO-88	VA-180	VCA-2033	NS ⁴³⁷
V8 6.1L (W) FI	VO-88	VA-180	VCA-2033	NS ⁴³⁷

Charger

V6 2.7L (D) FI	VO-88	VA-180	VCA-2033	NS ⁴³⁷
V6 3.5L (V) FI	VO-88	VA-180	VCA-2033	NS ⁴³⁷
V8 5.7L (T) FI	VO-88	VA-180	VCA-2033	NS ⁴³⁷
V8 6.1L (W) FI	VO-88	VA-180	VCA-2033	NS ⁴³⁷

Dakota

V6 3.7L (K) FI	VO-88	VA-90		NS ⁴³⁷
V8 4.7L (P) FI (Flex Fuel)	VO-88	VA-90		NS ⁴³⁷

Grand Caravan

V6 3.3L (E) FI (Flex Fuel)	VO-25	VA-154	VCA-1044	NS ⁴³⁷
V6 3.8L (1) FI	VO-25	VA-154	VCA-1044	NS ⁴³⁷
V6 4.0L (X) FI	VO-88	VA-154	VCA-1044	NS ⁴³⁷

Journey

4 cyl 2.4L	VO-88	VA-245	VCA-1069	NS ⁴³⁷
V6 3.5L	VO-88	VA-245	VCA-1069	NS ⁴³⁷

Nitro

V6 3.7L (K) FI	VO-88	VA-232	VCA-1093	NS ⁴³⁷
----------------	-------	--------	----------	-------------------

Se reporter à table de matière pour les notes en bas de page en français. Utilize el contenido para ver notas a pie.

NS - Non-Serviceable / Non réparable / No reparable LF - Life-Time Filter / Filtro para toda la vida / Filtre à vie

⁴³⁷ Requires replacement of the complete fuel pump/fuel filter module.



DODGE (ALSO SEE RAM) (cont'd)

	Oil	Air	Cabin*	Fuel
2010				
Nitro				
V6 4.0L (X) FI	VO-88	VA-232	VCA-1093	NS ⁴³⁷
Ram Pickup 1500, 2500, 3500				
V6 3.7L (K) FI	VO-88	VA-160		NS ⁴³⁷
V8 4.7L (P) FI (Flex Fuel)	VO-88	VA-160		NS ⁴³⁷
V8 5.7L (T) FI	VO-88	VA-160		NS ⁴³⁷
6 cyl. 5.9L Diesel Turbo	VO-64	VA-177		
6 cyl. 6.7L (L) Diesel Turbo	VO-64	VA-264		
Ram 4500, 5500				
6 cyl. 6.7L (L) Diesel Turbo	VO-64	VA-264		
Viper				
V10 8.4L (Z) FI	VO-88	VA-330		NS ⁴³⁷
2009				
Avenger				
4 cyl. 2.4L (B) FI	VO-88	VA-154	VCA-1069	NS ⁴³⁷
V6 2.7L (D) FI	VO-88	VA-154	VCA-1069	NS ⁴³⁷
V6 3.5L (V) FI	VO-88	VA-154	VCA-1069	NS ⁴³⁷
Caliber				
4 cyl. 1.8L (C) FI	VO-88	VA-229	VCA-1069	NS ⁴³⁷
4 cyl. 2.0L (A) FI	VO-88	VA-229	VCA-1069	NS ⁴³⁷
4 cyl. 2.4L (B) FI	VO-88	VA-229	VCA-1069	NS ⁴³⁷
4 cyl. 2.4L (F) FI Turbo	VO-88		VCA-1069	NS ⁴³⁷
Challenger				
V6 3.5L (V) FI	VO-88	VA-180	VCA-2033	NS ⁴³⁷
V8 5.7L (T) FI	VO-88	VA-180	VCA-2033	NS ⁴³⁷
V8 6.1L (W) FI	VO-88	VA-180	VCA-2033	NS ⁴³⁷
Charger				
V6 2.7L (D) FI	VO-88	VA-180	VCA-2033	NS ⁴³⁷
V6 3.5L (V) FI	VO-88	VA-180	VCA-2033	NS ⁴³⁷
V8 5.7L (T) FI	VO-88	VA-180	VCA-2033	NS ⁴³⁷
V8 6.1L (W) FI	VO-88	VA-180	VCA-2033	NS ⁴³⁷
Dakota				
V6 3.7L (K) FI	VO-88	VA-90		NS ⁴³⁷
V8 4.7L (P) FI (Flex Fuel)	VO-88	VA-90		NS ⁴³⁷
Durango				
V6 3.7L (K) FI	VO-88	VA-179		NS ⁴³⁷
V8 4.7L (P) FI Flex Fuel	VO-88	VA-179		NS ⁴³⁷
V8 5.7L (T) FI	VO-88	VA-179		NS ⁴³⁷
V8 5.7L (T) FI (Hybrid)	VO-88			NS ⁴³⁷
Grand Caravan				
V6 3.3L (E) FI (Flex Fuel)	VO-25	VA-154	VCA-1044	NS ⁴³⁷
V6 3.8L (I) FI	VO-25	VA-154	VCA-1044	NS ⁴³⁷
V6 4.0L (X) FI	VO-88	VA-154	VCA-1044	NS ⁴³⁷
Journey				
4 cyl. 2.4L	VO-88	VA-245	VCA-1069	NS ⁴³⁷
V6 3.5L	VO-88	VA-245	VCA-1069	NS ⁴³⁷
Nitro				
V6 3.7L (K) FI	VO-88	VA-232	VCA-1093	NS ⁴³⁷
V6 4.0L (X) FI	VO-88	VA-232	VCA-1093	NS ⁴³⁷
Ram Pickup 1500, 2500, 3500				
V6 3.7L (K) FI	VO-88	VA-160		NS ⁴³⁷
V8 4.7L (P) FI (Flex Fuel)	VO-88	VA-160		NS ⁴³⁷
V8 5.7L (T) FI	VO-88	VA-160		NS ⁴³⁷

Se reporter à table de matière pour les notes en bas de page en français. Utilize el contenido para ver notas a pie.

NS - Non-Serviceable / Non réparable / No reparable LF - Life-Time Filter / Filtro para toda la vida / Filtre à vie

⁴³⁷ Requires replacement of the complete fuel pump/fuel filter module.



DODGE (ALSO SEE RAM) (cont'd)

2009

Ram Pickup 1500, 2500, 3500

6 cyl. 5.9L (7) Diesel Turbo	VO-64	VA-177		
6 cyl 6.7L (L) Diesel Turbo	VO-64	VA-264		

Ram 4500, 5500

6 cyl 6.7L (L) Diesel Turbo	VO-64	VA-264		
-----------------------------	-------	--------	--	--

Sprinter Van

V6 3.0L (5) DI Turbo Diesel	VO-129	VA-349	VCA-1142	
-----------------------------	--------	--------	----------	--

Viper

V10 8.4L (Z) FI	VO-88	VA-330		NS ⁴³⁷
-----------------	-------	--------	--	-------------------

2008

Avenger

4 cyl 2.4L (K,J) FI	VO-88	VA-154	VCA-1069	NS ⁴³⁷
V6 2.7L (R) FI	VO-88 ^{X370}			
	VO-95 ^{1504, Z370}	VA-154	VCA-1069	NS ⁴³⁷
V6 3.5L (M) FI	VO-88 ^{X370}			
	VO-95 ^{1504, Z370}	VA-154	VCA-1069	NS ⁴³⁷

Caliber

4 cyl 1.8L (C) FI	VO-88	VA-229	VCA-1069	NS ⁴³⁷
4 cyl 2.0L (B) FI	VO-88	VA-229	VCA-1069	NS ⁴³⁷
4 cyl 2.4L (K) FI	VO-88	VA-229	VCA-1069	NS ⁴³⁷
4 cyl 2.4L (F) FI Turbo	VO-88		VCA-1069	NS ⁴³⁷

Challenger

V8 6.1L (W) FI	VO-88	VA-180	VCA-2033	NS ⁴³⁷
----------------	-------	--------	----------	-------------------

Charger

V6 2.7L (R) FI	VO-88 ^{X370}			
	VO-95 ^{1504, Z370}	VA-180	VCA-2033	NS ⁴³⁷
V6 3.5L (G) FI	VO-88 ^{X370}			
	VO-95 ^{1504, Z370}	VA-180	VCA-2033	NS ⁴³⁷
V8 5.7L (H) FI	VO-88 ^{X370}			
	VO-95 ^{1504, Z370}	VA-180	VCA-2033	NS ⁴³⁷
V8 6.1L (W) FI	VO-88 ^{X370}			
	VO-95 ^{1504, Z370}	VA-180	VCA-2033	NS ⁴³⁷

Dakota

V6 3.7L (K) FI	VO-118	VA-90		NS ⁴³⁷
V8 4.7L (N) FI	VO-88 ^{X370}			
	VO-95 ^{1504, Z370}	VA-90		NS ⁴³⁷

Durango

V6 3.7L (K) FI	VO-118	VA-179		NS ⁴³⁷
V8 4.7L (N,P) FI	VO-88 ^{X370}			
	VO-95 ^{1504, Z370}	VA-179		NS ⁴³⁷
V8 5.7L (2) FI	VO-88 ^{X370}			
	VO-95 ^{1504, Z370}	VA-179		NS ⁴³⁷

Grand Caravan

V6 3.3L (H) FI	VO-25	VA-154	VCA-1044	NS ⁴³⁷
V6 3.8L (P) FI	VO-25	VA-154	VCA-1044	NS ⁴³⁷
V6 4.0L (X) FI	VO-25	VA-154	VCA-1044	NS ⁴³⁷

Magnum

V6 2.7L (T) FI	VO-88 ^{X370}			
	VO-95 ^{1504, Z370}	VA-180	VCA-2033	NS ⁴³⁷
V6 3.5L (V) FI	VO-88 ^{X370}			
	VO-95 ^{1504, Z370}	VA-180	VCA-2033	NS ⁴³⁷
V8 5.7L (2) FI	VO-88 ^{X370}			
	VO-95 ^{1504, Z370}	VA-180	VCA-2033	NS ⁴³⁷

Se reporter à table de matière pour les notes en bas de page en français. Utilize el contenido para ver notas a pie.

NS - Non-Serviceable / Non réparable / No reparable LF - Life-Time Filter / Filtro para toda la vida / Filtre à vie

⁴³⁷ Requires replacement of the complete fuel pump/fuel filter module. ¹⁵⁰⁴Alternate. Primary VO-25 ^{X370}with 22 MM THREADED STUD ^{Z370}with 3/4 INCH THREADED STUD.



DODGE (ALSO SEE RAM) (cont'd)

2008				
Magnum				
V8 6.1L (3) FI	VO-88 ^{X370} VO-95 ^{1504, Z370}	VA-180	VCA-2033	NS ⁴³⁷
Nitro				
V6 3.7L (K) FI	VO-118	VA-232	VCA-1093	NS ⁴³⁷
V6 4.0L (6) FI	VO-95 ^{X504} VO-25 ^{Z504}	VA-232	VCA-1093	NS ⁴³⁷
Ram Pickup				
V6 3.7L (K) FI	VO-118	VA-160		NS ⁴³⁷
V8 4.7L (N) FI	VO-88 ^{X370} VO-95 ^{1504, Z370}	VA-160		NS ⁴³⁷
V8 5.7L (2,D) FI	VO-88 ^{X370} VO-95 ^{1504, Z370}	VA-160		NS ⁴³⁷
6 cyl. 5.9L (C) Diesel Turbo	VO-64	VA-177		
6 cyl. 6.7L (A) Diesel Turbo	VO-64	VA-264		
Ram 4500, 5500				
6 cyl. 6.7L (A) Diesel Turbo	VO-64	VA-264		
Sprinter Van				
V6 3.0L (5) DI Turbo Diesel	VO-129	VA-349	VCA-1142	
V6 3.5L (6) FI	VO-103	VA-349	VCA-1142	NS ⁴³⁷
Viper				
V10 8.4L (Z) FI	VO-88	VA-330		NS ⁴³⁷
2007				
Caliber				
4 cyl. 1.8L (C) FI	VO-88	VA-229	VCA-1069	NS ⁴³⁷
4 cyl. 2.0L (B) FI	VO-88	VA-229	VCA-1069	NS ⁴³⁷
4 cyl. 2.4L (K) FI	VO-88	VA-229	VCA-1069	NS ⁴³⁷
Caravan, Grand Caravan				
4 cyl. 2.4L (B) FI	VO-25	VA-154	VCA-1168	NS ⁴³⁷
V6 3.3L (E,R) FI	VO-25	VA-154	VCA-1168	NS ⁴³⁷
V6 3.8L (L) FI	VO-25	VA-154	VCA-1168	NS ⁴³⁷
Charger				
V6 2.7L (R) FI	VO-95 ^{X504} VO-25 ^{Z504}	VA-180	VCA-2033	NS ⁴³⁷
V6 3.5L (G) FI	VO-95 ^{X504} VO-25 ^{Z504}	VA-180	VCA-2033	NS ⁴³⁷
V8 5.7L (H) FI	VO-95 ^{X504} VO-25 ^{Z504}	VA-180	VCA-2033	NS ⁴³⁷
V8 6.1L (W) FI	VO-95 ^{X504} VO-25 ^{Z504}	VA-180	VCA-2033	NS ⁴³⁷
Dakota				
V6 3.7L (K) FI	VO-118	VA-90		NS ⁴³⁷
V8 4.7L (J,N,P) FI	VO-95 ^{X504} VO-25 ^{Z504}	VA-90		NS ⁴³⁷
Durango				
V6 3.7L (K) FI	VO-118	VA-179		NS ⁴³⁷
V8 4.7L (N,P) FI	VO-95 ^{X504} VO-25 ^{Z504}	VA-179		NS ⁴³⁷
V8 5.7L (2) FI	VO-95 ^{X504} VO-25 ^{Z504}	VA-179		NS ⁴³⁷
Magnum				
V6 2.7L (T) FI	VO-95 ^{X504} VO-25 ^{Z504}	VA-180	VCA-2033	NS ⁴³⁷

Se reporter à table de matière pour les notes en bas de page en français. Utilize el contenido para ver notas a pie.

NS - Non-Serviceable / Non réparable / No reparable LF - Life-Time Filter / Filtro para toda la vida / Filtre à vie

⁴³⁷ Requires replacement of the complete fuel pump/fuel filter module. ¹⁵⁰⁴ Alternate. Primary VO-25 ^{X370} with 22 MM THREADED STUD ^{X504} Alternate

^{Z370} with 3/4 INCH THREADED STUD. ^{Z504} Primary



DODGE (ALSO SEE RAM) (cont'd)

2007

Magnum

V6 3.5L (V) FI	VO-95 ^{X504} VO-25 ^{Z504}	VA-180	VCA-2033	NS ⁴³⁷
V8 5.7L (2) FI	VO-95 ^{X504} VO-25 ^{Z504}	VA-180	VCA-2033	NS ⁴³⁷
V8 6.1L (3) FI	VO-95 ^{X504} VO-25 ^{Z504}	VA-180	VCA-2033	NS ⁴³⁷

Nitro

V6 3.7L (K) FI	VO-118 VO-95 ^{X504}	VA-232		NS ⁴³⁷
V6 4.0L (6) FI	VO-25 ^{Z504}	VA-232		NS ⁴³⁷

Ram Pickup

V6 3.7L (K) FI	VO-118 VO-95 ^{X504}	VA-160		NS ⁴³⁷
V8 4.7L (N) FI	VO-25 ^{Z504} VO-95 ^{X504}	VA-160		NS ⁴³⁷
V8 4.7L (P) FI (Flex Fuel)	VO-25 ^{Z504} VO-95 ^{X504}	VA-160		NS ⁴³⁷
V8 5.7L (D,2) FI	VO-95 ^{X504} VO-25 ^{Z504}	VA-160		NS ⁴³⁷
6 cyl. 5.9L (C) Diesel Turbo	VO-25 ^{Z504} VO-64	VA-160 VA-177		NS ⁴³⁷
6 cyl 6.7L (A) Diesel Turbo	VO-64	VA-264		

Sprinter Van

V6 3.0L (5) DI Turbo Diesel	VO-129	VA-349	VCA-1142	
V6 3.5L (6) FI	VO-103	VA-349	VCA-1142	NS ⁴³⁷

2006

Caravan, Grand Caravan

4 cyl. 2.4L (B) FI	VO-25 VO-95 ^{X504}	VA-154	VCA-1168	NS ⁴³⁷
V6 3.3L (E,R) FI	VO-25 ^{Z504} VO-95 ^{X504}	VA-154	VCA-1168	NS ⁴³⁷
V6 3.8L (L) FI	VO-25 ^{Z504} VO-95 ^{X504}	VA-154	VCA-1168	NS ⁴³⁷

Charger

V6 2.7L (R) FI	VO-95 ^{X504} VO-25 ^{Z504}	VA-180	VCA-2033	NS ⁴³⁷
V6 3.5L (G) FI	VO-95 ^{X504} VO-25 ^{Z504}	VA-180	VCA-2033	NS ⁴³⁷
V8 5.7L (H) FI	VO-95 ^{X504} VO-25 ^{Z504}	VA-180	VCA-2033	NS ⁴³⁷
V8 6.1L (W) FI	VO-95 ^{X504} VO-25 ^{Z504}	VA-180	VCA-2033	NS ⁴³⁷

Dakota

V6 3.7L (K) FI	VO-118 VO-95 ^{X504}	VA-90		NS ⁴³⁷
V8 4.7L (J,N) FI	VO-25 ^{Z504}	VA-90		NS ⁴³⁷

Durango

V6 3.7L (K) FI	VO-118 VO-95 ^{X504}	VA-179		NS ⁴³⁷
V8 4.7L (N,P) FI	VO-25 ^{Z504} VO-95 ^{X504}	VA-179		NS ⁴³⁷
V8 5.7L (2) FI	VO-95 ^{X504} VO-25 ^{Z504}	VA-179		NS ⁴³⁷

Magnum

V6 2.7L (T) FI	VO-95 ^{X504} VO-25 ^{Z504}	VA-180	VCA-2033	NS ⁴³⁷
----------------	--	--------	----------	-------------------

Se reporter à table de matière pour les notes en bas de page en français. Utilize el contenido para ver notas a pie.

NS - Non-Serviceable / Non réparable / No reparable LF - Life-Time Filter / Filtro para toda la vida / Filtre à vie

⁴³⁷ Requires replacement of the complete fuel pump/fuel filter module. ^{X504}Alternate ^{Z504}Primary



DODGE (ALSO SEE RAM) (cont'd)

2006

Magnum

V6 3.5L (V) FI	VO-95 ^{X504} VO-25 ^{Z504}	VA-180	VCA-2033	NS ⁴³⁷
V8 5.7L (2) FI	VO-95 ^{X504} VO-25 ^{Z504}	VA-180	VCA-2033	NS ⁴³⁷
V8 6.1L (3) FI	VO-95 ^{X504} VO-25 ^{Z504}	VA-180	VCA-2033	NS ⁴³⁷

Ram Pickup

V6 3.7L (K) FI	VO-118	VA-160		NS ⁴³⁷
V8 4.7L (N) FI	VO-95 ^{X504} VO-25 ^{Z504}	VA-160		NS ⁴³⁷
V8 4.7L (P) FI (Flex Fuel)	VO-95 ^{X504} VO-25 ^{Z504}	VA-160		NS ⁴³⁷
V8 5.7L (D,2) FI	VO-95 ^{X504} VO-25 ^{Z504}	VA-160		NS ⁴³⁷
6 cyl. 5.9L (C) Diesel Turbo	VO-64	VA-177		
V10 8.3L (H) FI	VO-95 ^{X504} VO-25 ^{Z504}			NS ⁴³⁷

Sprinter Van

5 cyl. 2.7L (4) Diesel Turbo	VO-103	VA-380		
------------------------------	--------	--------	--	--

Stratus Sedan

4 cyl. 2.4L (X) FI	VO-25	VA-155		NS ⁴³⁷
V6 2.7L (R,T) FI	VO-95 ^{X504} VO-25 ^{Z504}	VA-155		NS ⁴³⁷

Viper

V10 8.3L (Z) FI	VO-95 ^{X504} VO-25 ^{Z504}			
-----------------	--	--	--	--

2005

Caravan, Grand Caravan

4 cyl. 2.4L (B) FI	VO-25	VA-154	VCA-1168	NS ⁴³⁷
V6 3.3L (E,R) FI	VO-95 ^{X504} VO-25 ^{Z504}	VA-154	VCA-1168	NS ⁴³⁷
V6 3.8L (L) FI	VO-95 ^{X504} VO-25 ^{Z504}	VA-154	VCA-1168	NS ⁴³⁷

Dakota

V6 3.7L (K) FI	VO-118	VA-90		NS ⁴³⁷
V8 4.7L (J,N) FI	VO-95 ^{X504} VO-25 ^{Z504}	VA-90		NS ⁴³⁷

Durango

V6 3.7L (K) FI	VO-118	VA-179		NS ⁴³⁷
V8 4.7L (N) FI	VO-95 ^{X504} VO-25 ^{Z504}	VA-179		NS ⁴³⁷
V8 5.7L (D) FI	VO-95 ^{X504} VO-25 ^{Z504}	VA-179		NS ⁴³⁷

Magnum

V6 2.7L (T) FI	VO-95 ^{X504} VO-25 ^{Z504}	VA-180	VCA-2033	NS ⁴³⁷
V6 3.5L (V) FI	VO-95 ^{X504} VO-25 ^{Z504}	VA-180	VCA-2033	NS ⁴³⁷
V8 5.7L (2) FI	VO-95 ^{X504} VO-25 ^{Z504}	VA-180	VCA-2033	NS ⁴³⁷

Neon

4 cyl. 2.0L (C) FI	VO-25	VA-137		NS ⁴³⁷
--------------------	-------	--------	--	-------------------

Se reporter à table de matière pour les notes en bas de page en français. Utilize el contenido para ver notas a pie.

NS - Non-Serviceable / Non réparable / No repairable LF - Life-Time Filter / Filtro para toda la vida / Filtre a vie

⁴³⁷ Requires replacement of the complete fuel pump/fuel filter module. ^{X504}Alternate ^{Z504}Primary



DODGE (ALSO SEE RAM) (cont'd)

2005

Neon

4 cyl. 2.4L (S) Turbo FI (SRT-4)	VO-118	VA-137		NS ⁴³⁷
----------------------------------	--------	--------	--	-------------------

Ram Pickup

V6 3.7L (K) FI	VO-118	VA-160		NS ⁴³⁷
V8 4.7L (N) FI	VO-95 ^{X504}			
	VO-25 ^{Z504}	VA-160		NS ⁴³⁷
V8 4.7L (P) FI (Flex Fuel)	VO-95 ^{X504}			
	VO-25 ^{Z504}	VA-160		NS ⁴³⁷
V8 5.7L (D) FI	VO-95 ^{X504}			
	VO-25 ^{Z504}	VA-160		NS ⁴³⁷
6 cyl. 5.9L (6,C) Diesel Turbo	VO-64	VA-177		
V10 8.3L (H) FI	VO-95 ^{X504}			
	VO-25 ^{Z504}			NS ⁴³⁷

Sprinter Van

5 cyl. 2.7L (4) Diesel Turbo	VO-69	VA-380		
------------------------------	-------	--------	--	--

Stratus Coupe

4 cyl. 2.4L (G) FI	VO-106	VA-104		NS ⁴³⁷
V6 3.0L (H) FI	VO-106	VA-104		NS ⁴³⁷

Stratus Sedan

4 cyl. 2.4L (J,X) FI	VO-25	VA-155		NS ⁴³⁷
V6 2.7L (R,T) FI	VO-95 ^{X504}			
	VO-25 ^{Z504}	VA-155		NS ⁴³⁷

SX (Canada)

4 cyl. 2.0L (C) FI	VO-25	VA-137		NS ⁴³⁷
--------------------	-------	--------	--	-------------------

Viper

V10 8.3L (Z) FI	VO-95 ^{X504}			
	VO-25 ^{Z504}			

2004

Caravan, Grand Caravan

4 cyl. 2.4L (B) FI	VO-25	VA-154	VCA-1168	
V6 3.3L (R) FI	VO-95 ^{X504}			
	VO-25 ^{Z504}	VA-154	VCA-1168	
V6 3.3L (3,S) FI (Flex Fuel)	VO-95 ^{X504}			
	VO-25 ^{Z504}	VA-154	VCA-1168	
V6 3.8L (L) FI	VO-95 ^{X504}			
	VO-25 ^{Z504}	VA-154	VCA-1168	

Dakota

V6 3.7L (K) FI	VO-118	VA-90		NS ⁴³⁷
V8 4.7L (N) FI	VO-95 ^{X504}			
	VO-25 ^{Z504}	VA-90		NS ⁴³⁷

Durango

V6 3.7L (K) FI	VO-118	VA-179		NS ⁴³⁷
V8 4.7L (N) FI	VO-95 ^{X504}			
	VO-25 ^{Z504}	VA-179		NS ⁴³⁷
V8 5.7L (D) FI	VO-95 ^{X504}			
	VO-25 ^{Z504}	VA-179		NS ⁴³⁷

Intrepid

V6 2.7L (R) FI	VO-95 ^{X504}			
	VO-25 ^{Z504}	VA-116		NS ⁴³⁷
V6 3.5L (G,M,V) FI	VO-95 ^{X504}			
	VO-25 ^{Z504}	VA-116		NS ⁴³⁷

Neon

4 cyl. 2.0L (C,F) FI	VO-25	VA-137		NS ⁴³⁷
----------------------	-------	--------	--	-------------------

Se reporter à table de matière pour les notes en bas de page en français. Utilize el contenido para ver notas a pie.

NS - Non-Serviceable / Non réparable / No repairable LF - Life-Time Filter / Filtro para toda la vida / Filtre à vie

⁴³⁷ Requires replacement of the complete fuel pump/fuel filter module. ^{X504}Alternate ^{Z504}Primary



DODGE (ALSO SEE RAM) (cont'd)

2004				
Neon				
4 cyl 2.4L (S) Turbo FI (SRT-4)	VO-118	VA-137		NS ⁴³⁷
Ram Pickup				
V6 3.7L (K) FI	VO-118	VA-160		NS ⁴³⁷
V8 4.7L (N) FI	VO-95 ^{X504}			
	VO-25 ^{Z504}	VA-160		NS ⁴³⁷
V8 4.7L (P) FI (Flex Fuel)	VO-95 ^{X504}			
	VO-25 ^{Z504}	VA-160		NS ⁴³⁷
V8 5.7L (D) FI	VO-95 ^{X504}			
	VO-25 ^{Z504}	VA-160		NS ⁴³⁷
6 cyl. 5.9L (6,C) Diesel Turbo	VO-64	VA-177		
V10 8.3L (H) FI	VO-95 ^{X504}			
	VO-25 ^{Z504}			NS ⁴³⁷
Sprinter Van				
5 cyl. 2.7L Diesel Turbo	VO-69	VA-380		
Stratus Convertible				
4 cyl. 2.4L (J,X) FI	VO-25	VA-155		NS ⁴³⁷
V6 2.7L (R,T) FI	VO-95 ^{X504}			
	VO-25 ^{Z504}	VA-155		NS ⁴³⁷
Stratus Coupe				
4 cyl. 2.4L (G) FI	VO-106	VA-104		NS ⁴³⁷
V6 3.0L (H) FI	VO-106	VA-104		NS ⁴³⁷
Stratus Sedan				
4 cyl. 2.4L (J,X) FI	VO-25	VA-155		NS ⁴³⁷
V6 2.7L (R,T) FI	VO-95 ^{X504}			
	VO-25 ^{Z504}	VA-155		NS ⁴³⁷
SX (Canada)				
4 cyl. 2.0L (C) FI	VO-25	VA-137		NS ⁴³⁷
Viper				
V10 8.3L (Z) FI	VO-95 ^{X504}			
	VO-25 ^{Z504}			
2003				
Caravan, Grand Caravan				
4 cyl. 2.4L (B) FI	VO-25	VA-154	VCA-1168	
V6 3.3L (R) FI	VO-95 ^{X504}			
	VO-25 ^{Z504}	VA-154	VCA-1168	
V6 3.3L (3) FI (Flex Fuel)	VO-95 ^{X504}			
	VO-25 ^{Z504}	VA-154	VCA-1168	
V6 3.8L (L) FI	VO-95 ^{X504}			
	VO-25 ^{Z504}	VA-154	VCA-1168	
Dakota				
V6 3.9L (X) FI	VO-95 ^{X504}			
	VO-25 ^{Z504}	VA-90		NS ⁴³⁷
V8 4.7L (N) FI	VO-95 ^{X504}			
	VO-25 ^{Z504}	VA-90		NS ⁴³⁷
V8 5.9L (Z) FI	VO-95 ^{X504}			
	VO-25 ^{Z504}	VA-90		NS ⁴³⁷
Durango				
V8 4.7L (N) FI	VO-95 ^{X504}			
	VO-25 ^{Z504}	VA-90		NS ⁴³⁷
V8 5.9L (Z) FI	VO-95 ^{X504}			
	VO-25 ^{Z504}	VA-90		NS ⁴³⁷

Se reporter à table de matière pour les notes en bas de page en français. Utilize el contenido para ver notas a pie.

NS - Non-Serviceable / Non réparable / No reparable LF - Life-Time Filter / Filtro para toda la vida / Filtre à vie

⁴³⁷ Requires replacement of the complete fuel pump/fuel filter module. ^{X504}Alternate ^{Z504}Primary



DODGE (ALSO SEE RAM) (cont'd)

2003

Intrepid

V6 2.7L (R) FI	VO-95 ^{X504} VO-25 ^{Z504}	VA-116		NS ⁴³⁷
V6 3.5L (G,M,V) FI	VO-95 ^{X504} VO-25 ^{Z504}	VA-116		NS ⁴³⁷

Neon

4 cyl. 2.0L (C,F) FI	VO-25	VA-137		NS ⁴³⁷
4 cyl. 2.4L Turbo FI (SRT-4)	VO-118	VA-137		NS ⁴³⁷

Ram Pickup

V6 3.7L (K) FI	VO-118	VA-160		NS ⁴³⁷
V8 4.7L (N) FI	VO-95 ^{X504} VO-25 ^{Z504}	VA-160		NS ⁴³⁷
V8 5.7L (D) FI	VO-95 ^{X504} VO-25 ^{Z504}	VA-160		NS ⁴³⁷
6 cyl. 5.9L (6,C) Diesel Turbo	VO-64	VA-177		
V8 5.9L (Z) FI	VO-95 ^{X504} VO-25 ^{Z504}	VA-160		NS ⁴³⁷
V10 8.0L (W) FI	VO-95 ^{X504} VO-25 ^{Z504}	VA-132		NS ⁴³⁷

Ram Van

V6 3.9L (X) FI	VO-95 ^{X504} VO-25 ^{Z504}	VA-321		NS ⁴³⁷
V8 5.2L (Y) FI	VO-95 ^{X504} VO-25 ^{Z504}	VA-321		NS ⁴³⁷
V8 5.2L (T) FI (CNG)	VO-95 ^{X504} VO-25 ^{Z504}	VA-321		NS
V8 5.9L (Z) FI	VO-95 ^{X504} VO-25 ^{Z504}	VA-321		NS ⁴³⁷

Sprinter Van

5 cyl. 2.7L Diesel Turbo	VO-69	VA-380		
--------------------------	-------	--------	--	--

Stratus Convertible

4 cyl. 2.4L (X) FI	VO-25	VA-155		NS ⁴³⁷
V6 2.7L (R,T) FI	VO-95 ^{X504} VO-25 ^{Z504}	VA-155		NS ⁴³⁷

Stratus Coupe

4 cyl. 2.4L (G) FI	VO-106	VA-104		NS ⁴³⁷
V6 3.0L (H) FI	VO-106	VA-104		NS ⁴³⁷

Stratus Sedan

4 cyl. 2.4L (X) FI	VO-25	VA-155		NS ⁴³⁷
V6 2.7L (R,T) FI	VO-95 ^{X504} VO-25 ^{Z504}	VA-155		NS ⁴³⁷

SX (Canada)

4 cyl. 2.0L (C) FI	VO-25	VA-137		NS ⁴³⁷
--------------------	-------	--------	--	-------------------

Viper

V10 8.3L (Z) FI	VO-95 ^{X504} VO-25 ^{Z504}			
-----------------	--	--	--	--

2002

Caravan, Grand Caravan

4 cyl. 2.4L (B) FI	VO-25	VA-154	VCA-1168	
V6 3.3L (R) FI	VO-95 ^{X504} VO-25 ^{Z504}	VA-154	VCA-1168	
V6 3.3L (3) FI (Flex Fuel)	VO-95 ^{X504} VO-25 ^{Z504}	VA-154	VCA-1168	

Se reporter à table de matière pour les notes en bas de page en français. Utilize el contenido para ver notas a pie.

NS - Non-Serviceable / Non réparable / No repairable LF - Life-Time Filter / Filtro para toda la vida / Filtre à vie

⁴³⁷ Requires replacement of the complete fuel pump/fuel filter module. ^{X504}Alternate ^{Z504}Primary



DODGE (ALSO SEE RAM) (cont'd)

2002

Caravan, Grand Caravan

V6 3.8L (L) FI	VO-95 ^{X504} VO-25 ^{Z504}	VA-154	VCA-1168	
----------------	--	--------	----------	--

Dakota

4 cyl. 2.5L (P) FI	VO-95 ^{X504} VO-25 ^{Z504}	VA-90		NS ⁴³⁷
V6 3.9L (X) FI	VO-95 ^{X504} VO-25 ^{Z504}	VA-90		NS ⁴³⁷
V8 4.7L (N) FI	VO-95 ^{X504} VO-25 ^{Z504}	VA-90		NS ⁴³⁷
V8 5.9L (Z) FI	VO-95 ^{X504} VO-25 ^{Z504}	VA-90		NS ⁴³⁷

Durango

V8 4.7L (N) FI	VO-95 ^{X504} VO-25 ^{Z504}	VA-90		NS ⁴³⁷
V8 5.9L (Z) FI	VO-95 ^{X504} VO-25 ^{Z504}	VA-90		NS ⁴³⁷

Intrepid

V6 2.7L (R) FI	VO-95 ^{X504} VO-25 ^{Z504}	VA-116		NS ⁴³⁷
V6 3.5L (GM) FI	VO-95 ^{X504} VO-25 ^{Z504}	VA-116		NS ⁴³⁷

Neon

4 cyl. 2.0L (C,F) FI	VO-25	VA-137		NS ⁴³⁷
----------------------	-------	--------	--	-------------------

Ram Pickup 1500

V6 3.7L (K) FI	VO-118	VA-160		NS ⁴³⁷
V8 4.7L (N) FI	VO-95 ^{X504} VO-25 ^{Z504}	VA-160		NS ⁴³⁷
V8 5.9L (Z) FI	VO-95 ^{X504} VO-25 ^{Z504}	VA-160		NS ⁴³⁷

Ram Pickup 2500, 3500

6 cyl. 5.9L (6,7,C) Diesel Turbo	VO-64	VA-111		
V8 5.9L (5,Z) FI	VO-95 ^{X504} VO-25 ^{Z504}	VA-90		NS ⁴³⁷
V10 8.0L (W) FI	VO-95 ^{X504} VO-25 ^{Z504}	VA-132		NS ⁴³⁷

Ram Van

V6 3.9L (X) FI	VO-95 ^{X504} VO-25 ^{Z504}	VA-321		NS ⁴³⁷
V8 5.2L (Y) FI	VO-95 ^{X504} VO-25 ^{Z504}	VA-321		NS ⁴³⁷
V8 5.2L (T) FI (CNG)	VO-95 ^{X504} VO-25 ^{Z504}	VA-321		NS
V8 5.9L (Z) FI	VO-95 ^{X504} VO-25 ^{Z504}	VA-321		NS ⁴³⁷

Stratus Convertible

4 cyl. 2.4L (X) FI	VO-25	VA-155		NS ⁴³⁷
V6 2.7L (R) FI	VO-95 ^{X504} VO-25 ^{Z504}	VA-155		NS ⁴³⁷

Stratus Coupe

4 cyl. 2.4L (G) FI	VO-106	VA-104		NS ⁴³⁷
V6 3.0L (H) FI	VO-106	VA-104		NS ⁴³⁷

Se reporter à table de matière pour les notes en bas de page en français. Utilize el contenido para ver notas a pie.

NS - Non-Serviceable / Non réparable / No reparable LF - Life-Time Filter / Filtro para toda la vida / Filtre à vie

⁴³⁷ Requires replacement of the complete fuel pump/fuel filter module. ^{X504}Alternate ^{Z504}Primary



DODGE (ALSO SEE RAM) (cont'd)

2002

Stratus Sedan

4 cyl. 2.4L (X) FI	VO-25	VA-155		NS ⁴³⁷
V6 2.7L (R) FI	VO-95 ^{X504} VO-25 ^{Z504}	VA-155		NS ⁴³⁷

Viper

V10 8.0L (E) FI	VO-95 ^{X504} VO-25 ^{Z504}			
-----------------	--	--	--	--

2001

Caravan, Grand Caravan

4 cyl. 2.4L (B) FI	VO-25	VA-154	VCA-1168	
V6 3.3L (R) FI	VO-95 ^{X504} VO-25 ^{Z504}	VA-154	VCA-1168	
V6 3.3L (3,G) FI (Flex Fuel)	VO-95 ^{X504} VO-25 ^{Z504}	VA-154	VCA-1168	
V6 3.8L (L) FI	VO-95 ^{X504} VO-25 ^{Z504}	VA-154	VCA-1168	

Dakota

4 cyl. 2.5L (P) FI	VO-95 ^{X504} VO-25 ^{Z504}	VA-90		NS ⁴³⁷
V6 3.9L (X) FI	VO-95 ^{X504} VO-25 ^{Z504}	VA-90		NS ⁴³⁷
V8 4.7L (N) FI	VO-95 ^{X504} VO-25 ^{Z504}	VA-90		NS ⁴³⁷
V8 5.9L (Z) FI	VO-95 ^{X504} VO-25 ^{Z504}	VA-90		NS ⁴³⁷

Durango

V8 4.7L (N) FI	VO-95 ^{X504} VO-25 ^{Z504}	VA-90		NS ⁴³⁷
V8 5.9L (Z) FI	VO-95 ^{X504} VO-25 ^{Z504}	VA-90		NS ⁴³⁷

Intrepid

V6 2.7L (RU) FI	VO-95 ^{X504} VO-25 ^{Z504}	VA-116		NS ⁴³⁷
V6 3.5L (G,V) FI	VO-95 ^{X504} VO-25 ^{Z504}	VA-116		NS ⁴³⁷

Neon

4 cyl. 2.0L (C,F) FI	VO-25	VA-137		NS ⁴³⁷
----------------------	-------	--------	--	-------------------

Ram Pickup 1500, 2500, 3500

V6 3.9L (X) FI	VO-95 ^{X504} VO-25 ^{Z504}	VA-90		NS ⁴³⁷
V8 5.2L (Y) FI	VO-95 ^{X504} VO-25 ^{Z504}	VA-90		NS ⁴³⁷
6 cyl. 5.9L (6,7) Diesel Turbo	VO-64	VA-111		
V8 5.9L (5,Z) FI	VO-95 ^{X504} VO-25 ^{Z504}	VA-90		NS ⁴³⁷
V10 8.0L (W) FI	VO-95 ^{X504} VO-25 ^{Z504}	VA-132		NS ⁴³⁷

Ram Van

V6 3.9L (X) FI	VO-95 ^{X504} VO-25 ^{Z504}	VA-321		NS ⁴³⁷
V8 5.2L (Y) FI	VO-95 ^{X504} VO-25 ^{Z504}	VA-321		NS ⁴³⁷

Se reporter à table de matière pour les notes en bas de page en français. Utilize el contenido para ver notas a pie.

NS - Non-Serviceable / Non réparable / No repairable LF - Life-Time Filter / Filtro para toda la vida / Filtre à vie

⁴³⁷ Requires replacement of the complete fuel pump/fuel filter module. ^{X504}Alternate ^{Z504}Primary



DODGE (ALSO SEE RAM) (cont'd)

	Oil	Air	Cabin*	Fuel
2001				
Ram Van				
V8 5.2L (T) FI (CNG)	VO-95 ^{X504} VO-25 ^{Z504}	VA-321		NS
V8 5.9L (Z) FI	VO-95 ^{X504} VO-25 ^{Z504}	VA-321		NS ⁴³⁷
Stratus Convertible				
V6 2.7L (U) FI	VO-95 ^{X504} VO-25 ^{Z504}	VA-155		NS ⁴³⁷
Stratus Coupe				
4 cyl. 2.4L (G) FI	VO-106	VA-104		NS ⁴³⁷
V6 3.0L (H) FI	VO-106	VA-104		NS ⁴³⁷
Stratus Sedan				
4 cyl. 2.4L (X) FI	VO-25	VA-155		NS ⁴³⁷
V6 2.7L (U) FI	VO-95 ^{X504} VO-25 ^{Z504}	VA-155		NS ⁴³⁷
Viper				
V10 8.0L (E) FI	VO-95 ^{X504} VO-25 ^{Z504}			
2000				
Avenger				
V6 2.5L (N) FI	VO-95 ^{X504} VO-25 ^{Z504}	VA-104		
Caravan				
4 cyl. 2.4L (B) FI	VO-25	VA-69		
V6 3.0L (3) FI	VO-95 ^{X504} VO-25 ^{Z504}	VA-69		
V6 3.3L (R) FI	VO-95 ^{X504} VO-25 ^{Z504}	VA-69		
V6 3.3L (G) FI (Flex Fuel)	VO-95 ^{X504} VO-25 ^{Z504}	VA-69		
Dakota				
4 cyl. 2.5L (P) FI	VO-95 ^{X504} VO-25 ^{Z504}	VA-90		NS ⁴³⁷
V6 3.9L (X) FI	VO-95 ^{X504} VO-25 ^{Z504}	VA-90		NS ⁴³⁷
V8 4.7L (N) FI	VO-95 ^{X504} VO-25 ^{Z504}	VA-90		NS ⁴³⁷
V8 5.9L (Z) FI	VO-95 ^{X504} VO-25 ^{Z504}	VA-90		NS ⁴³⁷
Durango				
V8 4.7L (N) FI	VO-95 ^{X504} VO-25 ^{Z504}	VA-90		NS ⁴³⁷
V8 5.2L (Y) FI	VO-95 ^{X504} VO-25 ^{Z504}	VA-90		NS ⁴³⁷
V8 5.9L (Z) FI	VO-95 ^{X504} VO-25 ^{Z504}	VA-90		NS ⁴³⁷
Grand Caravan				
V6 3.0L (3) FI	VO-95 ^{X504} VO-25 ^{Z504}	VA-69		
V6 3.3L (R) FI	VO-95 ^{X504} VO-25 ^{Z504}	VA-69		
V6 3.3L (G) FI (Flex Fuel)	VO-95 ^{X504} VO-25 ^{Z504}	VA-69		

Se reporter à table de matière pour les notes en bas de page en français. Utilize el contenido para ver notas a pie.

NS - Non-Serviceable / Non réparable / No repairable LF - Life-Time Filter / Filtro para toda la vida / Filtre à vie

⁴³⁷ Requires replacement of the complete fuel pump/fuel filter module. ^{X504}Alternate ^{Z504}Primary



DODGE (ALSO SEE RAM) (cont'd)

2000

Grand Caravan

V6 3.8L (L) FI	VO-95 ^{X504} VO-25 ^{Z504}	VA-69		
----------------	--	-------	--	--

Intrepid

V6 2.7L (R,U) FI	VO-95 ^{X504} VO-25 ^{Z504}	VA-116		NS ⁴³⁷
V6 3.2L (J) FI	VO-95 ^{X504} VO-25 ^{Z504}	VA-116		NS ⁴³⁷
V6 3.5L (G,V) FI	VO-95 ^{X504} VO-25 ^{Z504}	VA-116		NS ⁴³⁷

Neon

4 cyl. 2.0L (C) FI	VO-25	VA-137		NS ⁴³⁷
--------------------	-------	--------	--	-------------------

Ram Pickup 1500, 2500, 3500

V6 3.9L (X) FI	VO-95 ^{X504} VO-25 ^{Z504}	VA-90		NS ⁴³⁷
V8 5.2L (Y) FI	VO-95 ^{X504} VO-25 ^{Z504}	VA-90		NS ⁴³⁷
6 cyl. 5.9L (6) Diesel Turbo	VO-64	VA-111		
V8 5.9L (5,Z) FI	VO-95 ^{X504} VO-25 ^{Z504}	VA-90		NS ⁴³⁷
V10 8.0L (W) FI	VO-95 ^{X504} VO-25 ^{Z504}	VA-132		NS ⁴³⁷

Ram Van

V6 3.9L (X) FI	VO-95 ^{X504} VO-25 ^{Z504}	VA-321		NS ⁴³⁷
V8 5.2L (Y) FI	VO-95 ^{X504} VO-25 ^{Z504}	VA-321		NS ⁴³⁷
V8 5.2L (T) FI (CNG)	VO-95 ^{X504} VO-25 ^{Z504}	VA-321		NS ⁴³⁷
V8 5.9L (Z) FI	VO-95 ^{X504} VO-25 ^{Z504}	VA-321		NS ⁴³⁷

Stratus

4 cyl. 2.0L (C) FI	VO-25	VA-112		
4 cyl. 2.4L (X) FI	VO-25	VA-112		
V6 2.5L (H) FI	VO-95 ^{X504} VO-25 ^{Z504}	VA-112		

Viper

V10 8.0L (E) FI	VO-95 ^{X504} VO-25 ^{Z504}			
-----------------	--	--	--	--

1999

Avenger

4 cyl. 2.0L (Y) FI	VO-95 ^{X504} VO-25 ^{Z504}	VA-104		
V6 2.5L (N) FI	VO-95 ^{X504} VO-25 ^{Z504}	VA-104		

Caravan

4 cyl. 2.4L (B) FI	VO-25	VA-69		
V6 3.0L (3) FI	VO-95 ^{X504} VO-25 ^{Z504}	VA-69		
V6 3.3L (R) FI	VO-95 ^{X504} VO-25 ^{Z504}	VA-69		
V6 3.3L (G) FI (Flex Fuel)	VO-95 ^{X504} VO-25 ^{Z504}	VA-69		

Se reporter à table de matière pour les notes en bas de page en français. Utilize el contenido para ver notas a pie.

NS - Non-Serviceable / Non réparable / No reparable LF - Life-Time Filter / Filtro para toda la vida / Filtre à vie

⁴³⁷ Requires replacement of the complete fuel pump/fuel filter module. ^{X504}Alternate ^{Z504}Primary



DODGE (ALSO SEE RAM) (cont'd)

1999

Caravan

V6 3.8L (L) FI	VO-95 ^{X504} VO-25 ^{Z504}	VA-69		
----------------	--	-------	--	--

Dakota

4 cyl. 2.5L (P) FI	VO-95 ^{X504} VO-25 ^{Z504}	VA-90		NS ⁴³⁷
V6 3.9L (X) FI	VO-95 ^{X504} VO-25 ^{Z504}	VA-90		NS ⁴³⁷
V8 5.2L (Y) FI	VO-95 ^{X504} VO-25 ^{Z504}	VA-90		NS ⁴³⁷
V8 5.9L (Z) FI	VO-95 ^{X504} VO-25 ^{Z504}	VA-90		NS ⁴³⁷

Durango

V6 3.9L (X) FI	VO-95 ^{X504} VO-25 ^{Z504}	VA-90		NS ⁴³⁷
V8 5.2L (Y) FI	VO-95 ^{X504} VO-25 ^{Z504}	VA-90		NS ⁴³⁷
V8 5.9L (Z) FI	VO-95 ^{X504} VO-25 ^{Z504}	VA-90		NS ⁴³⁷

Grand Caravan

V6 3.0L (3) FI	VO-95 ^{X504} VO-25 ^{Z504}	VA-69		
V6 3.3L (R) FI	VO-95 ^{X504} VO-25 ^{Z504}	VA-69		
V6 3.3L (G) FI (Flex Fuel)	VO-95 ^{X504} VO-25 ^{Z504}	VA-69		
V6 3.8L (L) FI	VO-95 ^{X504} VO-25 ^{Z504}	VA-69		

Intrepid

V6 2.7L (R) FI	VO-95 ^{X504} VO-25 ^{Z504}	VA-116		NS ⁴³⁷
V6 3.2L (J) FI	VO-95 ^{X504} VO-25 ^{Z504}	VA-116		NS ⁴³⁷

Neon

4 cyl. 2.0L (C,Y) FI	VO-25	VA-69		NS ⁴³⁷
----------------------	-------	-------	--	-------------------

Ram Pickup 1500, 2500, 3500

V6 3.9L (X) FI	VO-95 ^{X504} VO-25 ^{Z504}	VA-90		NS ⁴³⁷
V8 5.2L FI	VO-95 ^{X504} VO-25 ^{Z504}	VA-90		NS ⁴³⁷
6 cyl. 5.9L (6) Diesel Turbo	VO-64	VA-111		
V8 5.9L (5,Z) FI	VO-95 ^{X504} VO-25 ^{Z504}	VA-90		NS ⁴³⁷
V10 8.0L (W) FI	VO-95 ^{X504} VO-25 ^{Z504}	VA-132		NS ⁴³⁷

Ram Van

V6 3.9L (X) FI	VO-95 ^{X504} VO-25 ^{Z504}	VA-321		NS ⁴³⁷
V8 5.2L (Y) FI	VO-95 ^{X504} VO-25 ^{Z504}	VA-321		NS ⁴³⁷
V8 5.2L (T) FI (CNG)	VO-95 ^{X504} VO-25 ^{Z504}	VA-321		NS ⁴³⁷
V8 5.9L (Z) FI	VO-95 ^{X504} VO-25 ^{Z504}	VA-321		NS ⁴³⁷

Se reporter à table de matière pour les notes en bas de page en français. Utilize el contenido para ver notas a pie.

NS - Non-Serviceable / Non réparable / No reparable LF - Life-Time Filter / Filtro para toda la vida / Filtre à vie

⁴³⁷ Requires replacement of the complete fuel pump/fuel filter module. ^{X504}Alternate ^{Z504}Primary



DODGE (ALSO SEE RAM) (cont'd)

1999

Stratus

4 cyl. 2.0L (C) FI	VO-25	VA-112		
4 cyl. 2.4L (X) FI	VO-25	VA-112		
V6 2.5L (H) FI	VO-95 ^{X504} VO-25 ^{Z504}	VA-112		

Viper

V10 8.0L (E) FI	VO-95 ^{X504} VO-25 ^{Z504}			
-----------------	--	--	--	--

1998

Avenger

4 cyl. 2.0L (Y) FI	VO-95 ^{X504} VO-25 ^{Z504}			
V6 2.5L (N) FI	VO-95 ^{X504} VO-25 ^{Z504}	VA-104		

Caravan

4 cyl. 2.4L (B) FI	VO-25	VA-69		
V6 3.0L (3) FI	VO-95 ^{X504} VO-25 ^{Z504}	VA-69		
V6 3.3L (R) FI	VO-95 ^{X504} VO-25 ^{Z504}	VA-69		
V6 3.3L (G) FI (Flex Fuel)	VO-95 ^{X504} VO-25 ^{Z504}	VA-69		
V6 3.8L (L) FI	VO-95 ^{X504} VO-25 ^{Z504}	VA-69		

Dakota

4 cyl. 2.5L (P) FI	VO-95 ^{X504} VO-25 ^{Z504}	VA-90		NS ⁴³⁷
V6 3.9L (X) FI	VO-95 ^{X504} VO-25 ^{Z504}	VA-90		NS ⁴³⁷
V8 5.2L (Y) FI	VO-95 ^{X504} VO-25 ^{Z504}	VA-90		NS ⁴³⁷
V8 5.9L (Z) FI	VO-95 ^{X504} VO-25 ^{Z504}	VA-90		NS ⁴³⁷

Durango

V6 3.9L (X) FI	VO-95 ^{X504} VO-25 ^{Z504}	VA-90		NS ⁴³⁷
V8 5.2L (Y) FI	VO-95 ^{X504} VO-25 ^{Z504}	VA-90		NS ⁴³⁷
V8 5.9L (Z) FI	VO-95 ^{X504} VO-25 ^{Z504}	VA-90		NS ⁴³⁷

Grand Caravan

V6 3.0L (3) FI	VO-95 ^{X504} VO-25 ^{Z504}	VA-69		
V6 3.3L (R) FI	VO-95 ^{X504} VO-25 ^{Z504}	VA-69		
V6 3.3L (G) FI (Flex Fuel)	VO-95 ^{X504} VO-25 ^{Z504}	VA-69		
V6 3.8L (L) FI	VO-95 ^{X504} VO-25 ^{Z504}	VA-69		

Intrepid

V6 2.7L (R) FI	VO-95 ^{X504} VO-25 ^{Z504}	VA-116		NS ⁴³⁷
V6 3.2L (J) FI	VO-95 ^{X504} VO-25 ^{Z504}	VA-116		NS ⁴³⁷

Se reporter à table de matière pour les notes en bas de page en français. Utilize el contenido para ver notas a pie.

NS - Non-Serviceable / Non réparable / No repairable LF - Life-Time Filter / Filtro para toda la vida / Filtre à vie

⁴³⁷ Requires replacement of the complete fuel pump/fuel filter module. ^{X504}Alternate ^{Z504}Primary



DODGE (ALSO SEE RAM) (cont'd)

1998				
Neon				
4 cyl. 2.0L (C,Y) FI	VO-25	VA-69		NS ⁴³⁷
Ram Pickup 1500, 2500, 3500				
V6 3.9L (X) FI	VO-95 ^{X504} VO-25 ^{Z504}	VA-90		NS ⁴³⁷
V8 5.2L FI	VO-95 ^{X504} VO-25 ^{Z504}	VA-90		NS ⁴³⁷
6 cyl. 5.9L (D,6) Diesel Turbo	VO-64	VA-111		
V8 5.9L (5,Z) FI	VO-95 ^{X504} VO-25 ^{Z504}	VA-90		NS ⁴³⁷
V10 8.0L (W) FI	VO-95 ^{X504} VO-25 ^{Z504}	VA-132		NS ⁴³⁷
Ram Van				
V6 3.9L (X) FI	VO-95 ^{X504} VO-25 ^{Z504}	VA-321		NS ⁴³⁷
V8 5.2L (Y) FI	VO-95 ^{X504} VO-25 ^{Z504}	VA-321		NS ⁴³⁷
V8 5.9L (Z) FI	VO-95 ^{X504} VO-25 ^{Z504}	VA-321		NS ⁴³⁷
Stratus				
4 cyl. 2.0L (C) FI	VO-25	VA-112		
4 cyl. 2.4L (X) FI	VO-25	VA-112		
V6 2.5L (H) FI	VO-95 ^{X504} VO-25 ^{Z504}	VA-112		
Viper				
V10 8.0L (E) FI	VO-95 ^{X504} VO-25 ^{Z504}			
1997				
Avenger				
4 cyl. 2.0L (Y) FI	VO-95 ^{X504} VO-25 ^{Z504}	VA-104		
V6 2.5L (N) FI	VO-95 ^{X504} VO-25 ^{Z504}	VA-104		
Caravan				
4 cyl. 2.4L (B) FI	VO-25	VA-69		
V6 3.0L (3) FI	VO-95 ^{X504} VO-25 ^{Z504}	VA-69		
V6 3.3L (R) FI	VO-95 ^{X504} VO-25 ^{Z504}	VA-69		
V6 3.8L (L) FI	VO-95 ^{X504} VO-25 ^{Z504}	VA-69		
Dakota				
4 cyl. 2.5L (P) FI	VO-95 ^{X504} VO-25 ^{Z504}	VA-90		NS ⁴³⁷
V6 3.9L (X) FI	VO-95 ^{X504} VO-25 ^{Z504}	VA-90		NS ⁴³⁷
V8 5.2L (Y) FI	VO-95 ^{X504} VO-25 ^{Z504}	VA-90		NS ⁴³⁷
Grand Caravan				
4 cyl. 2.4L (B) FI	VO-25	VA-69		
V6 3.0L (3) FI	VO-95 ^{X504} VO-25 ^{Z504}	VA-69		

Se reporter à table de matière pour les notes en bas de page en français. Utilize el contenido para ver notas a pie.

NS - Non-Serviceable / Non réparable / No reparable LF - Life-Time Filter / Filtro para toda la vida / Filtre à vie

⁴³⁷ Requires replacement of the complete fuel pump/fuel filter module. ^{X504}Alternate ^{Z504}Primary



DODGE (ALSO SEE RAM) (cont'd)

1997

Grand Caravan

V6 3.3L (R) FI	VO-95 ^{X504} VO-25 ^{Z504}	VA-69		
V6 3.8L (L) FI	VO-95 ^{X504} VO-25 ^{Z504}	VA-69		

Intrepid

V6 3.3L (T) FI	VO-95 ^{X504} VO-25 ^{Z504}	VA-107		
V6 3.5L (F) FI	VO-95 ^{X504} VO-25 ^{Z504}	VA-107		

Neon

4 cyl. 2.0L (C,Y) FI	VO-25	VA-69		NS ⁴³⁷
----------------------	-------	-------	--	-------------------

Ram Pickup 1500, 2500, 3500

V6 3.9L (X) FI	VO-95 ^{X504} VO-25 ^{Z504}	VA-90		NS ⁴³⁷
V8 5.2L (Y) FI	VO-95 ^{X504} VO-25 ^{Z504}	VA-90		NS ⁴³⁷
V8 5.2L (T) FI (CNG)	VO-95 ^{X504} VO-25 ^{Z504}	VA-90		NS ⁴³⁷
6 cyl. 5.9L (D) Diesel Turbo	VO-64	VA-111		NS ⁴³⁷
V8 5.9L (5,Z) FI	VO-95 ^{X504} VO-25 ^{Z504}	VA-90		NS ⁴³⁷
V10 8.0L (W) FI	VO-95 ^{X504} VO-25 ^{Z504}	VA-132		NS ⁴³⁷

Ram Van

V6 3.9L (X) FI	VO-95 ^{X504} VO-25 ^{Z504}	VA-321		NS ⁴³⁷
V8 5.2L (Y) FI	VO-95 ^{X504} VO-25 ^{Z504}	VA-321		NS ⁴³⁷
V8 5.2L (T) FI (CNG)	VO-95 ^{X504} VO-25 ^{Z504}	VA-321		NS ⁴³⁷
V8 5.9L (Z) FI	VO-95 ^{X504} VO-25 ^{Z504}	VA-321		NS ⁴³⁷

Stratus

4 cyl. 2.0L (C) FI	VO-25	VA-112		
4 cyl. 2.4L (X) FI	VO-25	VA-112		
V6 2.5L (H) FI	VO-95 ^{X504} VO-25 ^{Z504}	VA-112		

Viper

V10 8.0L (E) FI	VO-95 ^{X504} VO-25 ^{Z504}			
-----------------	--	--	--	--

1996

Avenger

4 cyl. 2.0L (Y) FI	VO-95 ^{X504} VO-25 ^{Z504}	VA-104		
V6 2.5L (N) FI	VO-95 ^{X504} VO-25 ^{Z504}	VA-104		

Caravan

4 cyl. 2.4L (B) FI	VO-25	VA-69		
V6 3.0L (3) FI	VO-95 ^{X504} VO-25 ^{Z504}	VA-69		
V6 3.3L (R) FI	VO-95 ^{X504} VO-25 ^{Z504}	VA-69		

Se reporter à table de matière pour les notes en bas de page en français. Utilize el contenido para ver notas a pie.

NS - Non-Serviceable / Non réparable / No reparable LF - Life-Time Filter / Filtro para toda la vida / Filtre à vie

⁴³⁷ Requires replacement of the complete fuel pump/fuel filter module. ^{X504}Alternate ^{Z504}Primary



DODGE (ALSO SEE RAM) (cont'd)

1996				
Caravan				
V6 3.8L (L) FI	VO-95 ^{X504} VO-25 ^{Z504}	VA-69		
Dakota				
4 cyl. 2.5L (P) FI	VO-95 ^{X504} VO-25 ^{Z504}	VA-40		
V6 3.9L (X) FI	VO-95 ^{X504} VO-25 ^{Z504}	VA-321		NS ⁴³⁷
V8 5.2L (Y) FI	VO-95 ^{X504} VO-25 ^{Z504}	VA-321		NS ⁴³⁷
V8 5.2L (T) FI (CNG)	VO-95 ^{X504} VO-25 ^{Z504}	VA-321		NS ⁴³⁷
Grand Caravan				
4 cyl. 2.4L (B) FI	VO-25	VA-69		
V6 3.0L (3) FI	VO-95 ^{X504} VO-25 ^{Z504}	VA-69		
V6 3.3L (R) FI	VO-95 ^{X504} VO-25 ^{Z504}	VA-69		
V6 3.3L (J) FI (CNG)	VO-95 ^{X504} VO-25 ^{Z504}	VA-69		
V6 3.8L (L) FI	VO-95 ^{X504} VO-25 ^{Z504}	VA-69		
Intrepid				
V6 3.3L (T) FI	VO-95 ^{X504} VO-25 ^{Z504}	VA-107		
V6 3.5L (F) FI	VO-95 ^{X504} VO-25 ^{Z504}	VA-107		
Neon				
4 cyl. 2.0L (C,Y) FI	VO-25	VA-69		
Ram Pickup 1500, 2500, 3500				
V6 3.9L (X) FI	VO-95 ^{X504} VO-25 ^{Z504}	VA-90		NS ⁴³⁷
V8 5.2L (Y) FI	VO-95 ^{X504} VO-25 ^{Z504}	VA-90		NS ⁴³⁷
V8 5.2L (T) FI (CNG)	VO-95 ^{X504} VO-25 ^{Z504}	VA-90		NS ⁴³⁷
6 cyl. 5.9L (C) Diesel Turbo	VO-64	VA-111		
V8 5.9L (Z,5) FI	VO-95 ^{X504} VO-25 ^{Z504}	VA-90		NS ⁴³⁷
V10 8.0L (W) FI	VO-95 ^{X504} VO-25 ^{Z504}	VA-132		NS ⁴³⁷
Ram Van				
V6 3.9L (X) FI	VO-95 ^{X504} VO-25 ^{Z504}	VA-321		NS ⁴³⁷
V8 5.2L (Y) FI	VO-95 ^{X504} VO-25 ^{Z504}	VA-321		NS ⁴³⁷
V8 5.2L (T) FI (CNG)	VO-95 ^{X504} VO-25 ^{Z504}	VA-321		NS ⁴³⁷
V8 5.9L (Z) FI	VO-95 ^{X504} VO-25 ^{Z504}	VA-321		NS ⁴³⁷
Stealth				
V6 3.0L (J) FI Non Turbo DOHC	VO-106	VA-99		
V6 3.0L (H) FI Non Turbo SOHC	VO-106	VA-99		
V6 3.0L (K) FI Turbo	VO-106	VA-99		

Se reporter à table de matière pour les notes en bas de page en français. Utilize el contenido para ver notas a pie.

NS - Non-Serviceable / Non réparable / No reparable LF - Life-Time Filter / Filtro para toda la vida / Filtre à vie

⁴³⁷ Requires replacement of the complete fuel pump/fuel filter module. ^{X504}Alternate ^{Z504}Primary



DODGE (ALSO SEE RAM) (cont'd)

1996

Stratus

4 cyl. 2.0L (C) FI	VO-25	VA-112		
4 cyl. 2.4L (X) FI	VO-25	VA-112		
V6 2.5L (H) FI	VO-95 ^{X504} VO-25 ^{Z504}	VA-112		

Viper

V10 8.0L (E) FI	VO-95 ^{X504} VO-25 ^{Z504}			
-----------------	--	--	--	--

1995

Avenger

4 cyl. 2.0L (Y) FI	VO-95 ^{X504} VO-25 ^{Z504}	VA-104		
V6 2.5L (N) FI	VO-95 ^{X504} VO-25 ^{Z504}	VA-104		

Caravan, Grand Caravan

4 cyl. 2.5L (K) FI	VO-95 ^{X504} VO-25 ^{Z504}	VA-40		
V6 3.0L (3) FI	VO-95 ^{X504} VO-25 ^{Z504}	VA-69		
V6 3.3L (R) FI	VO-95 ^{X504} VO-25 ^{Z504}	VA-40		
V6 3.3L (J) FI (CNG)	VO-95 ^{X504} VO-25 ^{Z504}	VA-40		
V6 3.8L (L) FI	VO-95 ^{X504} VO-25 ^{Z504}	VA-40		

Colt

4 cyl. 1.5L (A) FI (Canada)	VO-106	VA-387		
-----------------------------	--------	--------	--	--

Dakota

4 cyl. 2.5L (G) FI	VO-95 ^{X504} VO-25 ^{Z504}	VA-40		NS ⁴³⁷
V6 3.9L (X) FI	VO-95 ^{X504} VO-25 ^{Z504}	VA-321		NS ⁴³⁷
V8 5.2L (Y) FI	VO-95 ^{X504} VO-25 ^{Z504}	VA-321		NS ⁴³⁷
V8 5.2L (T) FI (CNG)	VO-95 ^{X504} VO-25 ^{Z504}	VA-321		NS ⁴³⁷

Intrepid

V6 3.3L (T) FI	VO-95 ^{X504} VO-25 ^{Z504}	VA-107		
V6 3.3L (U) FI (Flex Fuel)	VO-95 ^{X504} VO-25 ^{Z504}	VA-107		
V6 3.5L (F) FI	VO-95 ^{X504} VO-25 ^{Z504}	VA-107		

Neon

4 cyl. 2.0L (C,Y) FI	VO-25	VA-69		
----------------------	-------	-------	--	--

Ram Pickup 1500, 2500, 3500

V6 3.9L (X) FI	VO-95 ^{X504} VO-25 ^{Z504}	VA-90		NS ⁴³⁷
V8 5.2L (Y) FI	VO-95 ^{X504} VO-25 ^{Z504}	VA-90		NS ⁴³⁷
V8 5.2L (T) FI (CNG)	VO-95 ^{X504} VO-25 ^{Z504}	VA-90		NS ⁴³⁷
6 cyl. 5.9L (C) Diesel Turbo	VO-64	VA-111		

Se reporter à table de matière pour les notes en bas de page en français. Utilize el contenido para ver notas a pie.

NS - Non-Serviceable / Non réparable / No reparable LF - Life-Time Filter / Filtro para toda la vida / Filtre à vie

⁴³⁷ Requires replacement of the complete fuel pump/fuel filter module. ^{X504}Alternate ^{Z504}Primary



DODGE (ALSO SEE RAM) (cont'd)

1995

Ram Pickup 1500, 2500, 3500

V8 5.9L (Z,5) FI	VO-95 ^{X504} VO-25 ^{Z504}	VA-90		NS ⁴³⁷
V10 8.0L (W) FI	VO-95 ^{X504} VO-25 ^{Z504}	VA-132		NS ⁴³⁷

Ram Van

V6 3.9L (X) FI	VO-95 ^{X504} VO-25 ^{Z504}	VA-321		NS ⁴³⁷
V8 5.2L (Y) FI	VO-95 ^{X504} VO-25 ^{Z504}	VA-321		NS ⁴³⁷
V8 5.2L (T) FI (CNG)	VO-95 ^{X504} VO-25 ^{Z504}	VA-321		NS ⁴³⁷
V8 5.9L (Z,5) FI	VO-95 ^{X504} VO-25 ^{Z504}	VA-321		NS ⁴³⁷

Spirit

4 cyl. 2.5L (K) FI	VO-95 ^{X504} VO-25 ^{Z504}			
V6 3.0L (3) FI	VO-95 ^{X504} VO-25 ^{Z504}	VA-69		

Stealth

V6 3.0L (J) FI Non Turbo DOHC	VO-106	VA-99		
V6 3.0L (H) FI Non Turbo SOHC	VO-106	VA-99		
V6 3.0L (K) FI Turbo	VO-106	VA-99		

Stratus

4 cyl. 2.0L (C) FI	VO-25	VA-112		
4 cyl. 2.4L (X) FI	VO-25	VA-112		
V6 2.5L (H) FI	VO-95 ^{X504} VO-25 ^{Z504}	VA-112		

Viper

V10 8.0L (E) FI	VO-95 ^{X504} VO-25 ^{Z504}			
-----------------	--	--	--	--

1994

Spirit

4 cyl. 2.5L (K) FI	VO-95 ^{X504} VO-25 ^{Z504}			
--------------------	--	--	--	--

EAGLE

1998

Talon

4 cyl. 2.0L (Y) FI Non Turbo	VO-95 ^{X504} VO-25 ^{Z504}	VA-104		
4 cyl. 2.0L (F) FI Turbo	VO-106	VA-104		

1997

Talon

4 cyl. 2.0L (Y) FI Non Turbo	VO-95 ^{X504} VO-25 ^{Z504}	VA-104		
4 cyl. 2.0L (F) FI Turbo	VO-106	VA-104		

Vision

V6 3.3L (T) FI	VO-95 ^{X504} VO-25 ^{Z504}	VA-107		
V6 3.5L (F) FI	VO-95 ^{X504} VO-25 ^{Z504}	VA-107		

Se reporter à table de matière pour les notes en bas de page en français. Utilize el contenido para ver notas a pie.

NS - Non-Serviceable / Non réparable / No reparable LF - Life-Time Filter / Filtro para toda la vida / Filtre à vie

⁴³⁷ Requires replacement of the complete fuel pump/fuel filter module. ^{X504}Alternate ^{Z504}Primary



EAGLE (cont'd)

1996

Summit

4 cyl. 1.5L (A) FI	VO-106	VA-387		
4 cyl. 1.8L (C) FI (Sedan)	VO-106	VA-387		
4 cyl. 1.8L (C) FI (Wagon)	VO-106	VA-104		
4 cyl. 2.4L (G) FI (Wagon)	VO-106	VA-104		

Talon

4 cyl. 2.0L (Y) FI Non Turbo	VO-95 ^{X504} VO-25 ^{Z504}	VA-104		
4 cyl. 2.0L (F) FI Turbo	VO-106	VA-104		

Vision

V6 3.3L (T) FI	VO-95 ^{X504} VO-25 ^{Z504}	VA-107		
V6 3.5L (F) FI	VO-95 ^{X504} VO-25 ^{Z504}	VA-107		

1995

Summit

4 cyl. 1.5L (A) FI	VO-106	VA-387		
4 cyl. 1.8L (C) FI (Sedan and Coupe)	VO-106	VA-387		
4 cyl. 1.8L (C) FI (Wagon)	VO-106	VA-104		
4 cyl. 2.4L (G) FI (Wagon)	VO-106	VA-104		

Talon

4 cyl. 2.0L (Y) FI Non Turbo	VO-95 ^{X504} VO-25 ^{Z504}	VA-104		
4 cyl. 2.0L (E,F) FI Turbo	VO-106	VA-104		

Vision

V6 3.3L (T) FI	VO-95 ^{X504} VO-25 ^{Z504}	VA-107		
V6 3.5L (F) FI	VO-95 ^{X504} VO-25 ^{Z504}	VA-107		

1994

Summit

4 cyl. 1.5L (A) FI	VO-106	VA-387		
4 cyl. 1.8L (C) FI (Sedan and Coupe)	VO-106	VA-387		
4 cyl. 1.8L (C) FI (Wagon)	VO-106	VA-104		

Vision

V6 3.3L (T) FI	VO-95 ^{X504} VO-25 ^{Z504}	VA-107		
----------------	--	--------	--	--

FIAT

2019

124 Spyder

4 cyl. 1.4L Turbo	VO-116			NS ⁴³⁷
-------------------	--------	--	--	-------------------

500

Electric			VCA-1120	
4 cyl. 1.4L Turbo	VO-116	VA-473	VCA-1120	NS ⁴³⁷

500L

4 cyl. 1.4 Turbo	VO-116		VCA-1187	NS ⁴³⁷
------------------	--------	--	----------	-------------------

500X

4 cyl. 1.4L Turbo	VO-116	VA-455	VCA-1187	
4 cyl. 2.4	VO-88	VA-455	VCA-1187	

2018

124 Spyder

4 cyl. 1.4L Turbo	VO-116			NS ⁴³⁷
-------------------	--------	--	--	-------------------

Se reporter à table de matière pour les notes en bas de page en français. Utilize el contenido para ver notas a pie.

NS - Non-Serviceable / Non réparable / No reparable LF - Life-Time Filter / Filtro para toda la vida / Filtre à vie

⁴³⁷ Requires replacement of the complete fuel pump/fuel filter module. ^{X504}Alternate ^{Z504}Primary



FIAT (cont'd)

	Oil	Air	Cabin*	Fuel
2018				
500				
Electric 4 cyl. 1.4L Turbo	VO-116	VA-473	VCA-1120 VCA-1120	NS ⁴³⁷
500L				
4 cyl. 1.4 Turbo	VO-116		VCA-1187	NS ⁴³⁷
500X				
4 cyl. 1.4L Turbo	VO-116	VA-455	VCA-1187	
4 cyl. 2.4	VO-88	VA-455	VCA-1187	
Mobi (Mexico)				
4 cyl. 1.0	VO-106			
2017				
124 Spyder				
4 cyl. 1.4L Turbo	VO-116			NS ⁴³⁷
500				
Electric 4 cyl. 1.4L	VO-116	VA-310	VCA-1120 VCA-1120	NS ⁴³⁷
4 cyl. 1.4L Turbo	VO-116	VA-473	VCA-1120	NS ⁴³⁷
500L				
4 cyl. 1.4 Turbo	VO-116		VCA-1187	NS ⁴³⁷
500X				
4 cyl. 1.4L Turbo	VO-116	VA-455	VCA-1187	
4 cyl. 2.4	VO-88	VA-455	VCA-1187	
Mobi (Mexico)				
4 cyl. 1.0	VO-106			
2016				
500				
Electric 4 cyl. 1.4L	VO-116	VA-310	VCA-1120 VCA-1120	NS ⁴³⁷
4 cyl. 1.4L Turbo	VO-116	VA-473	VCA-1120	NS ⁴³⁷
500L				
4 cyl. 1.4 Turbo	VO-116		VCA-1187	NS ⁴³⁷
500X				
4 cyl. 1.4L Turbo	VO-116	VA-455	VCA-1187	
4 cyl. 2.4	VO-88	VA-455	VCA-1187	
2015				
500				
Electric 4 cyl. 1.4L	VO-116	VA-310	VCA-1120 VCA-1120	NS ⁴³⁷
4 cyl. 1.4L Turbo	VO-116	VA-473	VCA-1120	NS ⁴³⁷
500L				
4 cyl. 1.4 Turbo	VO-116		VCA-1187	NS ⁴³⁷
2014				
500				
Electric 4 cyl. 1.4L	VO-116	VA-310	VCA-1120 VCA-1120	NS ⁴³⁷
4 cyl. 1.4L Turbo	VO-116	VA-473	VCA-1120	NS ⁴³⁷
500L				
4 cyl. 1.4 Turbo	VO-116		VCA-1187	NS ⁴³⁷
2013				
500				
4 cyl. 1.4L	VO-116	VA-310	VCA-1120	NS ⁴³⁷
4 cyl. 1.4L Turbo	VO-116	VA-473	VCA-1120	NS ⁴³⁷

Se reporter à table de matière pour les notes en bas de page en français. Utilize el contenido para ver notas a pie.

NS - Non-Serviceable / Non réparable / No reparable LF - Life-Time Filter / Filtro para toda la vida / Filtre à vie

⁴³⁷ Requires replacement of the complete fuel pump/fuel filter module.



FIAT (cont'd)

2012

500

4 cyl. 1.4L	VO-116	VA-310	VCA-1120	NS ⁴³⁷
4 cyl. 1.4L Turbo	VO-116	VA-473	VCA-1120	NS ⁴³⁷

FISKER

2012

Karma

4 cyl. 2.0L FI (Hybrid)	VO-76	VA-360		
-------------------------	-------	--------	--	--

FORD

2019

Econoline

V8 6.2L	VO-88	VA-94		NS ⁴³⁷
V10 6.8L	VO-88	VA-94		NS ⁴³⁷

EcoSport

3 cyl. 1.0L Turbo	VO-25	VA-501	VCA-1177	
4 cyl. 2.0L Turbo	VO-25	VA-501	VCA-1177	

Edge

4 cyl. 2.0L Turbo	VO-25	VA-306	VCA-1174	
V6 2.7L Turbo	VO-115	VA-306	VCA-1174	

Escape

4 cyl 1.5L	VO-25	VA-288	VCA-1081	NS ⁴³⁷
4 cyl 2.0L	VO-25	VA-288	VCA-1081	NS ⁴³⁷
4 cyl 2.5L	VO-25	VA-298	VCA-1081	NS ⁴³⁷

Expedition

V6 3.5L Turbo	VO-88	VA-223	VCA-1185	NS ⁴³⁷
---------------	-------	--------	----------	-------------------

Explorer

4 cyl. 2.3L Turbo	VO-25	VA-224	VCA-1118	NS ⁴³⁷
V6 3.5L Non turbo	VO-88	VA-224	VCA-1118	NS ⁴³⁷
V6 3.5L Turbo	VO-88	VA-224	VCA-1118	NS ⁴³⁷

F53

V10 6.8	VO-88	VA-382		NS ⁴³⁷
---------	-------	--------	--	-------------------

F59

V10 6.8	VO-88	VA-223		
---------	-------	--------	--	--

Fiesta

3 cyl. 1.0L Turbo	VO-25	VA-284	VCA-1177	NS ⁴³⁷
4 cyl. 1.6L Non turbo	VO-25	VA-284	VCA-1177	NS ⁴³⁷
4 cyl. 1.6L Turbo	VO-25	VA-284	VCA-1177	NS ⁴³⁷

Flex

V6 3.5L Non turbo	VO-88	VA-224	VCA-1118	NS ⁴³⁷
V6 3.5L Turbo	VO-88	VA-224	VCA-1118	NS ⁴³⁷

Fusion

4 cyl. 1.5L Turbo	VO-25	VA-306	VCA-1174	NS ⁴³⁷
4 cyl. 2.0L Hybrid	VO-25	VA-429	VCA-1174	NS ⁴³⁷
4 cyl. 2.0L Turbo	VO-25	VA-306	VCA-1174	NS ⁴³⁷
4 cyl. 2.5L	VO-25	VA-306	VCA-1174	NS ⁴³⁷
V6 2.7L	VO-115	VA-306	VCA-1174	NS ⁴³⁷

Mustang

4 cyl. 2.3L Turbo	VO-25	VA-430	VCA-1186	NS ⁴³⁷
V8 5.0L	VO-88	VA-430	VCA-1186	NS ⁴³⁷
V8 5.2L	VO-115		VCA-1186	NS ⁴³⁷

Pickup F Series

V6 2.7L	VO-115	VA-223	VCA-1185	NS ⁴³⁷
V6 3.0L Diesel		VA-223	VCA-1185	

Se reporter à table de matière pour les notes en bas de page en français. Utilize el contenido para ver notas a pie.

NS - Non-Serviceable / Non réparable / No reparable LF - Life-Time Filter / Filtro para toda la vida / Filtre à vie

⁴³⁷ Requires replacement of the complete fuel pump/fuel filter module.



FORD (cont'd)

	Oil	Air	Cabin*	Fuel
2019				
Pickup F Series				
V6 3.3L	VO-88	VA-223	VCA-1185	NS ⁴³⁷
V6 3.5L Turbo	VO-88	VA-223	VCA-1185	NS ⁴³⁷
V8 5.0L	VO-88	VA-223	VCA-1185	NS ⁴³⁷
Pickup F250-F550 Super Duty				
V8 6.2L	VO-88	VA-463	VCA-1185	NS ⁴³⁷
V8 6.7L Diesel Turbo	VO-104	VA-462	VCA-1185	
V10 6.8L	VO-88	VA-463	VCA-1185	NS ⁴³⁷
Police Interceptor Sedan				
V6 3.5L Non turbo	VO-88	VA-224	VCA-1118	NS ⁴³⁷
V6 3.5L Turbo	VO-88	VA-224	VCA-1118	NS ⁴³⁷
V6 3.7L	VO-88	VA-224	VCA-1118	NS ⁴³⁷
Police Interceptor Utility				
V6 3.5L Turbo	VO-88	VA-224	VCA-1118	NS ⁴³⁷
V6 3.7L	VO-88	VA-224	VCA-1118	NS ⁴³⁷
Ranger				
4 cyl. 2.3L Turbo	VO-25			
Taurus				
V6 3.5L Non turbo	VO-88	VA-224	VCA-1118	NS ⁴³⁷
V6 3.5L Turbo	VO-88	VA-224	VCA-1118	NS ⁴³⁷
Transit				
L5 3.2 Diesel Turbo	VO-88	VA-451		
V6 3.5 Turbo	VO-88	VA-451		NS ⁴³⁷
V6 3.7	VO-88	VA-451		NS ⁴³⁷
Transit Connect				
4 cyl. 2.0L	VO-25		VCA-1081	NS ⁴³⁷
4 cyl. 2.5L	VO-25	VA-298	VCA-1081	NS ⁴³⁷
2018				
C-MAX				
4 cyl. 2.0L Hybrid	VO-25	VA-429	VCA-1081	NS ⁴³⁷
Econoline				
V8 6.2L	VO-88	VA-94		NS ⁴³⁷
V10 6.8L	VO-88	VA-94		NS ⁴³⁷
EcoSport				
3 cyl. 1.0L Turbo	VO-25	VA-501	VCA-1177	
4 cyl. 2.0L Turbo	VO-25	VA-501	VCA-1177	
Edge				
4 cyl. 2.0L Turbo	VO-25	VA-306	VCA-1174	
V6 2.7L Turbo	VO-115	VA-306	VCA-1174	
V6 3.5L	VO-88	VA-306	VCA-1174	
Escape				
4 cyl. 1.5L	VO-25	VA-288	VCA-1081	NS ⁴³⁷
4 cyl. 2.0L	VO-25	VA-288	VCA-1081	NS ⁴³⁷
4 cyl. 2.5L	VO-25	VA-298	VCA-1081	NS ⁴³⁷
Expedition				
V6 3.5L Turbo	VO-88	VA-223	VCA-1185	NS ⁴³⁷
Explorer				
4 cyl. 2.3L Turbo	VO-25	VA-224	VCA-1118	NS ⁴³⁷
V6 3.5L Non turbo	VO-88	VA-224	VCA-1118	NS ⁴³⁷
V6 3.5L Turbo	VO-88	VA-224	VCA-1118	NS ⁴³⁷
F53				
V10 6.8	VO-88	VA-382		NS ⁴³⁷

Se reporter à table de matière pour les notes en bas de page en français. Utilize el contenido para ver notas a pie.

NS - Non-Serviceable / Non réparable / No reparable LF - Life-Time Filter / Filtro para toda la vida / Filtre à vie

⁴³⁷ Requires replacement of the complete fuel pump/fuel filter module.



FORD (cont'd)

2018

F59

V10 6.8	VO-88	VA-223		
---------	-------	--------	--	--

Fiesta

4 cyl. 1.6L Non turbo	VO-25	VA-284	VCA-1177	NS ⁴³⁷
4 cyl. 1.6L Turbo	VO-25	VA-284	VCA-1177	NS ⁴³⁷

Flex

V6 3.5L (8) Non turbo	VO-88	VA-224	VCA-1118	NS ⁴³⁷
V6 3.5L (T) Turbo	VO-88	VA-224	VCA-1118	NS ⁴³⁷

Focus

Electric			VCA-1081	
3 cyl. 1.0L Turbo	VO-25	VA-288	VCA-1081	
4 cyl. 2.0L	VO-25	VA-288	VCA-1081	
4 cyl. 2.0L Turbo	VO-25	VA-288	VCA-1081	
4 cyl. 2.3L Turbo	VO-25	VA-288	VCA-1081	

Fusion

4 cyl. 1.5L FI Turbo	VO-25	VA-306	VCA-1174	NS ⁴³⁷
4 cyl. 2.0L Hybrid	VO-25	VA-429	VCA-1174	NS ⁴³⁷
4 cyl. 2.0L Turbo	VO-25	VA-306	VCA-1174	NS ⁴³⁷
4 cyl. 2.5L	VO-25	VA-306	VCA-1174	NS ⁴³⁷
V6 2.7L	VO-115	VA-306	VCA-1174	NS ⁴³⁷

Mustang

4 cyl. 2.3L Turbo	VO-25	VA-430	VCA-1186	NS ⁴³⁷
V8 5.0L	VO-88	VA-430	VCA-1186	NS ⁴³⁷
V8 5.2L	VO-115		VCA-1186	NS

Pickup F Series

V6 2.7L	VO-115	VA-223	VCA-1185	NS ⁴³⁷
V6 3.0L Diesel		VA-223	VCA-1185	
V6 3.3L	VO-88	VA-223	VCA-1185	NS ⁴³⁷
V6 3.5L Turbo	VO-88	VA-223	VCA-1185	NS ⁴³⁷
V8 5.0L	VO-88	VA-223	VCA-1185	NS ⁴³⁷

Pickup F250-F550 Super Duty

V8 6.2L	VO-88	VA-463	VCA-1185	NS ⁴³⁷
V8 6.7L Diesel Turbo	VO-104	VA-462	VCA-1185	
V10 6.8L	VO-88	VA-463	VCA-1185	NS ⁴³⁷

Police Interceptor Sedan

4 cyl. 2.0 Turbo	VO-25	VA-224	VCA-1118	NS ⁴³⁷
V6 3.5L Non turbo	VO-88	VA-224	VCA-1118	NS ⁴³⁷
V6 3.5L Turbo	VO-88	VA-224	VCA-1118	NS ⁴³⁷
V6 3.7L	VO-88	VA-224	VCA-1118	NS ⁴³⁷

Police Interceptor Utility

V6 3.5L Turbo	VO-88	VA-224	VCA-1118	NS ⁴³⁷
V6 3.7L	VO-88	VA-224	VCA-1118	NS ⁴³⁷

Taurus

V6 3.5L Non turbo	VO-88	VA-224	VCA-1118	NS ⁴³⁷
V6 3.5L Turbo	VO-88	VA-224	VCA-1118	NS ⁴³⁷

Transit

L5 3.2 Diesel Turbo	VO-88	VA-451		
V6 3.5 Turbo	VO-88	VA-451		NS ⁴³⁷
V6 3.7	VO-88	VA-451		NS ⁴³⁷

Transit Connect

4 cyl. 2.5L	VO-25	VA-298	VCA-1081	NS ⁴³⁷
-------------	-------	--------	----------	-------------------

Se reporter à table de matière pour les notes en bas de page en français. Utilize el contenido para ver notas a pie.

NS - Non-Serviceable / Non réparable / No repairable LF - Life-Time Filter / Filtro para toda la vida / Filtre à vie

⁴³⁷ Requires replacement of the complete fuel pump/fuel filter module.



FORD (cont'd)

	Oil	Air	Cabin*	Fuel
2017				
C-MAX				
4 cyl. 2.0L Hybrid	VO-25	VA-429	VCA-1081	NS ⁴³⁷
Econoline				
V8 6.2L	VO-88	VA-94		NS ⁴³⁷
V10 6.8L	VO-88	VA-94		NS ⁴³⁷
Edge				
4 cyl. 2.0L	VO-25	VA-306	VCA-1174	
V6 2.7L	VO-115	VA-306	VCA-1174	
V6 3.5L	VO-88	VA-306	VCA-1174	
Escape				
4 cyl. 1.5L	VO-25	VA-288	VCA-1081	NS ⁴³⁷
4 cyl. 2.0L	VO-25	VA-288	VCA-1081	NS ⁴³⁷
4 cyl. 2.5L	VO-25	VA-298	VCA-1081	NS ⁴³⁷
Expedition				
V6 3.5L Turbo	VO-88	VA-223		NS ⁴³⁷
Explorer				
4 cyl. 2.3L Turbo	VO-25	VA-224	VCA-1118	NS ⁴³⁷
V6 3.5L Non turbo	VO-88	VA-224	VCA-1118	NS ⁴³⁷
V6 3.5L Turbo	VO-88	VA-224	VCA-1118	NS ⁴³⁷
F53				
V10 6.8	VO-88	VA-382		NS ⁴³⁷
F59				
V10 6.8	VO-88	VA-223		
Fiesta				
3 cyl. 1.0L Turbo	VO-25	VA-284	VCA-1177	NS ⁴³⁷
4 cyl. 1.6L Non turbo	VO-25	VA-284	VCA-1177	NS ⁴³⁷
4 cyl. 1.6L Turbo	VO-25	VA-284	VCA-1177	NS ⁴³⁷
Flex				
V6 3.5L (8) Non turbo	VO-88	VA-224	VCA-1118	NS ⁴³⁷
V6 3.5L (T) Turbo	VO-88	VA-224	VCA-1118	NS ⁴³⁷
Focus				
Electric			VCA-1081	
3 cyl. 1.0L Turbo	VO-25	VA-288	VCA-1081	
4 cyl. 2.0L	VO-25	VA-288	VCA-1081	
4 cyl. 2.0L Turbo	VO-25	VA-288	VCA-1081	
4 cyl. 2.3L Turbo	VO-25	VA-288	VCA-1081	
Fusion				
4 cyl. 1.5L Turbo	VO-25	VA-306	VCA-1174	NS ⁴³⁷
4 cyl. 2.0L Hybrid	VO-25	VA-429	VCA-1174	NS ⁴³⁷
4 cyl. 2.0L Turbo	VO-25	VA-306	VCA-1174	NS ⁴³⁷
4 cyl. 2.5L	VO-25	VA-306	VCA-1174	NS ⁴³⁷
V6 2.7L	VO-115	VA-306	VCA-1174	NS ⁴³⁷
Mustang				
4 cyl. 2.3L Turbo	VO-25	VA-430	VCA-1186	NS ⁴³⁷
V6 3.7L	VO-88	VA-430	VCA-1186	NS ⁴³⁷
V8 5.0L	VO-88	VA-430	VCA-1186	NS ⁴³⁷
V8 5.2L			VCA-1186	NS
Pickup F Series				
V6 2.7L	VO-115	VA-223	VCA-1185	NS ⁴³⁷
V6 3.5L (8) Non turbo	VO-88	VA-223	VCA-1185	NS ⁴³⁷
V6 3.5L (G) Turbo	VO-88	VA-223	VCA-1185	NS ⁴³⁷
V8 5.0L	VO-88	VA-223	VCA-1185	NS ⁴³⁷

Se reporter à table de matière pour les notes en bas de page en français. Utilize el contenido para ver notas a pie.

NS - Non-Serviceable / Non réparable / No repairable LF - Life-Time Filter / Filtro para toda la vida / Filtre à vie

⁴³⁷ Requires replacement of the complete fuel pump/fuel filter module.



FORD (cont'd)

2017

Pickup F250-F550 Super Duty

V8 6.2L	VO-88	VA-463	VCA-1185	NS ⁴³⁷
V8 6.7L Diesel Turbo	VO-104	VA-462	VCA-1185	
V10 6.8L	VO-88	VA-463	VCA-1185	NS ⁴³⁷

Police Interceptor Sedan

4 cyl. 2.0 (9) FI Turbo	VO-25	VA-224	VCA-1118	NS ⁴³⁷
V6 3.5L (8) Non turbo	VO-88	VA-224	VCA-1118	NS ⁴³⁷
V6 3.5L (T) Turbo	VO-88	VA-224	VCA-1118	NS ⁴³⁷
V6 3.7L (K) FI	VO-88	VA-224	VCA-1118	NS ⁴³⁷

Police Interceptor Utility

V6 3.5L (T) Turbo	VO-88	VA-224	VCA-1118	NS ⁴³⁷
V6 3.7L (R)	VO-88	VA-224	VCA-1118	NS ⁴³⁷

Taurus

4 cyl. 2.0L	VO-25	VA-224	VCA-1118	NS ⁴³⁷
V6 3.5L Non turbo	VO-88	VA-224	VCA-1118	NS ⁴³⁷
V6 3.5L Turbo	VO-88	VA-224	VCA-1118	NS ⁴³⁷

Transit

L5 3.2 Diesel Turbo	VO-88	VA-451		
V6 3.5 Turbo	VO-88	VA-451		NS ⁴³⁷
V6 3.7	VO-88	VA-451		NS ⁴³⁷

Transit Connect

4 cyl. 2.5L	VO-25	VA-298	VCA-1081	NS ⁴³⁷
-------------	-------	--------	----------	-------------------

2016

C-MAX

4 cyl. 2.0L Hybrid	VO-25	VA-429	VCA-1081	NS ⁴³⁷
--------------------	-------	--------	----------	-------------------

Econoline

V8 5.4L	VO-88	VA-94		NS ⁴³⁷
V10 6.8L	VO-88	VA-94		NS ⁴³⁷

Edge

4 cyl. 2.0L	VO-25	VA-306	VCA-1174	
V6 2.7L	VO-115	VA-306	VCA-1174	
V6 3.5L	VO-88	VA-306	VCA-1174	

Escape

4 cyl 1.6L	VO-25	VA-288	VCA-1081	NS ⁴³⁷
4 cyl 2.0L	VO-25	VA-288	VCA-1081	NS ⁴³⁷
4 cyl 2.5L	VO-25	VA-298	VCA-1081	NS ⁴³⁷

Expedition

V6 3.5L Turbo	VO-88	VA-223		NS ⁴³⁷
---------------	-------	--------	--	-------------------

Explorer

4 cyl. 2.3L Turbo	VO-25	VA-224	VCA-1118	NS ⁴³⁷
V6 3.5L Non turbo	VO-88	VA-224	VCA-1118	NS ⁴³⁷
V6 3.5L Turbo	VO-88	VA-224	VCA-1118	NS ⁴³⁷

F53

V10 6.8	VO-88	VA-382		NS ⁴³⁷
---------	-------	--------	--	-------------------

F59

V10 6.8	VO-88	VA-223		
---------	-------	--------	--	--

Fiesta

3 cyl. 1.0L Turbo	VO-25	VA-284	VCA-1177	NS ⁴³⁷
4 cyl. 1.6L Non turbo	VO-25	VA-284	VCA-1177	NS ⁴³⁷
4 cyl. 1.6L Turbo	VO-25	VA-284	VCA-1177	NS ⁴³⁷

Flex

V6 3.5L (8) Non turbo	VO-88	VA-224	VCA-1118	NS ⁴³⁷
V6 3.5L (T) Turbo	VO-88	VA-224	VCA-1118	NS ⁴³⁷

Se reporter à table de matière pour les notes en bas de page en français. Utilize el contenido para ver notas a pie.

NS - Non-Serviceable / Non réparable / No reparable LF - Life-Time Filter / Filtro para toda la vida / Filtre à vie

⁴³⁷ Requires replacement of the complete fuel pump/fuel filter module.



FORD (cont'd)

	Oil	Air	Cabin*	Fuel
2016				
Focus				
Electric			VCA-1081	
3 cyl. 1.0L Turbo	VO-25	VA-288	VCA-1081	NS ⁴³⁷
4 cyl. 2.0L	VO-25	VA-288	VCA-1081	NS ⁴³⁷
4 cyl. 2.0L Turbo	VO-25	VA-288	VCA-1081	NS ⁴³⁷
4 cyl. 2.3L Turbo	VO-25	VA-288	VCA-1081	NS ⁴³⁷
Fusion				
4 cyl. 1.5L Turbo	VO-25	VA-306	VCA-1174	NS ⁴³⁷
4 cyl. 2.0L Hybrid	VO-25	VA-429	VCA-1174	NS ⁴³⁷
4 cyl. 2.0L Turbo	VO-25	VA-306	VCA-1174	NS ⁴³⁷
4 cyl. 2.5L	VO-25	VA-306	VCA-1174	NS ⁴³⁷
Mustang				
4 cyl. 2.3L Turbo	VO-25	VA-430	VCA-1186	NS ⁴³⁷
V6 3.7L	VO-88	VA-430	VCA-1186	NS ⁴³⁷
V8 5.0L	VO-88	VA-430	VCA-1186	NS ⁴³⁷
V8 5.2L			VCA-1186	NS
Pickup F Series				
V6 2.7L	VO-115	VA-223	VCA-1185	NS ⁴³⁷
V6 3.5L (8) Non turbo	VO-88	VA-223	VCA-1185	NS ⁴³⁷
V6 3.5L (G) Turbo	VO-88	VA-223	VCA-1185	NS ⁴³⁷
V8 5.0L	VO-88	VA-223	VCA-1185	NS ⁴³⁷
Pickup F250-F550 Super Duty				
V8 6.2L	VO-88	VA-223		NS ⁴³⁷
V8 6.7L Diesel Turbo	VO-104	VA-266		
V10 6.8L	VO-88	VA-223		NS ⁴³⁷
Police Interceptor Sedan				
4 cyl. 2.0L (9) Turbo	VO-25	VA-224	VCA-1118	NS ⁴³⁷
V6 3.5L (8) Non turbo	VO-88	VA-224	VCA-1118	NS ⁴³⁷
V6 3.5L (T) Turbo	VO-88	VA-224	VCA-1118	NS ⁴³⁷
V6 3.7L (K)	VO-88	VA-224	VCA-1118	NS ⁴³⁷
Police Interceptor Utility				
V6 3.5L (T) Turbo	VO-88	VA-224	VCA-1118	NS ⁴³⁷
V6 3.7L (R)	VO-88	VA-224	VCA-1118	NS ⁴³⁷
Taurus				
4 cyl. 2.0L	VO-25	VA-224	VCA-1118	NS ⁴³⁷
V6 3.5L Non turbo	VO-88	VA-224	VCA-1118	NS ⁴³⁷
V6 3.5L Turbo	VO-88	VA-224	VCA-1118	NS ⁴³⁷
Transit				
L5 3.2 Diesel Turbo	VO-88	VA-451		
V6 3.5 Turbo	VO-88	VA-451		NS ⁴³⁷
V6 3.7	VO-88	VA-451		NS ⁴³⁷
Transit Connect				
4 cyl. 1.6L Turbo	VO-25	VA-288	VCA-1081	NS ⁴³⁷
4 cyl. 2.5L	VO-25	VA-298	VCA-1081	NS ⁴³⁷
2015				
C-MAX				
4 cyl. 2.0L Hybrid	VO-25	VA-429	VCA-1081	NS ⁴³⁷
Econoline				
V8 5.4L	VO-88	VA-94		NS ⁴³⁷
V10 6.8L	VO-88	VA-94		NS ⁴³⁷
Edge				
4 cyl. 2.0L	VO-25	VA-306	VCA-1174	NS ⁴³⁷
V6 2.7L	VO-115	VA-306	VCA-1174	NS ⁴³⁷

Se reporter à table de matière pour les notes en bas de page en français. Utilize el contenido para ver notas a pie.

NS - Non-Serviceable / Non réparable / No reparable LF - Life-Time Filter / Filtro para toda la vida / Filtre à vie

⁴³⁷ Requires replacement of the complete fuel pump/fuel filter module.



FORD (cont'd)

2015

Edge

V6 3.5L	VO-88	VA-306	VCA-1174	NS ⁴³⁷
---------	-------	--------	----------	-------------------

Escape

4 cyl 1.6L	VO-25	VA-288	VCA-1081	NS ⁴³⁷
4 cyl 2.0L	VO-25	VA-288	VCA-1081	NS ⁴³⁷
4 cyl 2.5L	VO-25	VA-298	VCA-1081	NS ⁴³⁷

Expedition

V6 3.5L Turbo	VO-88	VA-223		NS ⁴³⁷
---------------	-------	--------	--	-------------------

Explorer

4 cyl. 2.0L Turbo	VO-25	VA-224	VCA-1118	NS ⁴³⁷
V6 3.5L Non turbo	VO-88	VA-224	VCA-1118	NS ⁴³⁷
V6 3.5L Turbo	VO-88	VA-224	VCA-1118	NS ⁴³⁷

F53

V10 6.8	VO-88	VA-382		NS ⁴³⁷
---------	-------	--------	--	-------------------

F59

V10 6.8	VO-88	VA-223		
---------	-------	--------	--	--

Fiesta

3 cyl. 1.0L Turbo	VO-25	VA-284	VCA-1177	NS ⁴³⁷
4 cyl. 1.6L Non turbo	VO-25	VA-284	VCA-1177	NS ⁴³⁷
4 cyl. 1.6L Turbo	VO-25	VA-284	VCA-1177	NS ⁴³⁷

Flex

V6 3.5L (8) Non turbo	VO-88	VA-224	VCA-1118	NS ⁴³⁷
V6 3.5L (T) Turbo	VO-88	VA-224	VCA-1118	NS ⁴³⁷

Focus

Electric			VCA-1081	
3 cyl. 1.0L Turbo	VO-25	VA-288	VCA-1081	NS ⁴³⁷
4 cyl. 2.0L	VO-25	VA-288	VCA-1081	NS ⁴³⁷
4 cyl. 2.0L Turbo	VO-25	VA-288	VCA-1081	NS ⁴³⁷

Fusion

4 cyl. 1.5L Turbo	VO-25	VA-306	VCA-1174	NS ⁴³⁷
4 cyl. 2.0L Hybrid	VO-25	VA-429	VCA-1174	NS ⁴³⁷
4 cyl. 2.0L Turbo	VO-25	VA-306	VCA-1174	NS ⁴³⁷
4 cyl. 2.5L	VO-25	VA-306	VCA-1174	NS ⁴³⁷

Mustang

4 cyl. 2.3L Turbo	VO-25	VA-430	VCA-1186	NS ⁴³⁷
V6 3.7L	VO-88	VA-430	VCA-1186	NS ⁴³⁷
V8 5.0L	VO-88	VA-430	VCA-1186	NS ⁴³⁷

Pickup F Series

V6 2.7L	VO-115	VA-223	VCA-1185	NS ⁴³⁷
V6 3.5L (8) Non turbo	VO-88	VA-223	VCA-1185	NS ⁴³⁷
V6 3.5L (G) Turbo	VO-88	VA-223	VCA-1185	NS ⁴³⁷
V8 5.0L	VO-88	VA-223	VCA-1185	NS ⁴³⁷

Pickup F250-F550 Super Duty

V8 6.2L	VO-88	VA-223		
V8 6.7L Diesel Turbo	VO-104	VA-266		
V10 6.8L	VO-88	VA-223		NS ⁴³⁷

Police Interceptor Sedan

4 cyl. 2.0L (9) Turbo	VO-25	VA-224	VCA-1118	NS ⁴³⁷
V6 3.5L (8) Non turbo	VO-88	VA-224	VCA-1118	NS ⁴³⁷
V6 3.5L (T) Turbo	VO-88	VA-224	VCA-1118	NS ⁴³⁷
V6 3.7L (K)	VO-88	VA-224	VCA-1118	NS ⁴³⁷

Police Interceptor Utility

V6 3.5L (T) Turbo	VO-88	VA-224	VCA-1118	NS ⁴³⁷
-------------------	-------	--------	----------	-------------------

Se reporter à table de matière pour les notes en bas de page en français. Utilize el contenido para ver notas a pie.

NS - Non-Serviceable / Non réparable / No reparable LF - Life-Time Filter / Filtro para toda la vida / Filtre à vie

⁴³⁷ Requires replacement of the complete fuel pump/fuel filter module.



FORD (cont'd)

	Oil	Air	Cabin*	Fuel
2015				
Police Interceptor Utility				
V6 3.7L (R)	VO-88	VA-224	VCA-1118	NS ⁴³⁷
Taurus				
4 cyl. 2.0L	VO-25	VA-224	VCA-1118	NS ⁴³⁷
V6 3.5L Non turbo	VO-88	VA-224	VCA-1118	NS ⁴³⁷
V6 3.5L Turbo	VO-88	VA-224	VCA-1118	NS ⁴³⁷
Transit				
L5 3.2 Diesel Turbo	VO-88	VA-451		
V6 3.5 Turbo	VO-88	VA-451		NS ⁴³⁷
V6 3.7	VO-88	VA-451		NS ⁴³⁷
Transit Connect				
4 cyl. 1.6L Turbo	VO-25	VA-288	VCA-1081	NS ⁴³⁷
4 cyl. 2.5L	VO-25	VA-298	VCA-1081	NS ⁴³⁷
2014				
C-MAX				
4 cyl. 2.0L Hybrid	VO-25	VA-429	VCA-1081	NS ⁴³⁷
Econoline				
V8 4.6L (Flex Fuel)	VO-88	VA-94		NS ⁴³⁷
V8 5.4L	VO-88	VA-94		NS ⁴³⁷
V8 5.4L (CNG/LPG)	VO-88	VA-94		
V10 6.8L (CNG/LPG)	VO-88	VA-94		
V10 6.8L GAS	VO-88	VA-94		NS ⁴³⁷
Edge				
4 cyl. 2.0L	VO-25	VA-224	VCA-1049	NS ⁴³⁷
V6 3.5L	VO-88	VA-224	VCA-1049	NS ⁴³⁷
V6 3.7L	VO-88	VA-224	VCA-1049	NS ⁴³⁷
Escape				
4 cyl. 1.6L	VO-25	VA-288	VCA-1081	NS ⁴³⁷
4 cyl. 2.0L	VO-25	VA-288	VCA-1081	NS ⁴³⁷
4 cyl. 2.5L	VO-25	VA-298	VCA-1081	NS ⁴³⁷
Expedition				
V8 5.4L (Flex Fuel)	VO-88	VA-223		NS ⁴³⁷
Explorer				
4 cyl. 2.0L Turbo	VO-25	VA-224	VCA-1118	NS ⁴³⁷
V6 3.5L Non turbo	VO-88	VA-224	VCA-1118	NS ⁴³⁷
V6 3.5L Turbo	VO-88	VA-224	VCA-1118	NS ⁴³⁷
F53				
V10 6.8	VO-88	VA-382		NS ⁴³⁷
F59				
V10 6.8	VO-88	VA-223		
Fiesta				
3 cyl. 1.0L Turbo	VO-25	VA-284	VCA-1177	NS ⁴³⁷
4 cyl. 1.6L Non turbo	VO-25	VA-284	VCA-1177	NS ⁴³⁷
4 cyl. 1.6L Turbo	VO-25	VA-284	VCA-1177	NS ⁴³⁷
Flex				
V6 3.5L (8) Non turbo	VO-88	VA-224	VCA-1118	NS ⁴³⁷
V6 3.5L (T) Turbo	VO-88	VA-224	VCA-1118	NS ⁴³⁷
Focus				
Electric			VCA-1081	
4 cyl. 2.0L	VO-25	VA-288	VCA-1081	NS ⁴³⁷
4 cyl. 2.0L Turbo	VO-25	VA-288	VCA-1081	NS ⁴³⁷
Fusion				
4 cyl. 1.5L Turbo	VO-25	VA-306	VCA-1174	NS ⁴³⁷

Se reporter à table de matière pour les notes en bas de page en français. Utilize el contenido para ver notas a pie.

NS - Non-Serviceable / Non réparable / No reparable LF - Life-Time Filter / Filtro para toda la vida / Filtre à vie

⁴³⁷ Requires replacement of the complete fuel pump/fuel filter module.



FORD (cont'd)

2014

Fusion

4 cyl. 1.6L Turbo	VO-25	VA-306	VCA-1174	NS ⁴³⁷
4 cyl. 2.0L Hybrid	VO-25	VA-429	VCA-1174	NS ⁴³⁷
4 cyl. 2.0L Turbo	VO-25	VA-306	VCA-1174	NS ⁴³⁷
4 cyl. 2.5L	VO-25	VA-306	VCA-1174	NS ⁴³⁷

Mustang

V6 3.7L	VO-88	VA-253	VCA-1102	
V8 5.0L	VO-88	VA-253	VCA-1102	
V8 5.8L Supercharged	VO-88		VCA-1102	

Pickup F Series

V6 3.5L Turbo	VO-88	VA-223		NS ⁴³⁷
V6 3.7L	VO-88	VA-223		NS ⁴³⁷
V6 3.7L (CNG/LPG)	VO-88	VA-223		NS ⁴³⁷
V8 5.0L	VO-88	VA-223		NS ⁴³⁷
V8 6.2L	VO-88	VA-223		NS ⁴³⁷

Pickup F250-F550 Super Duty

V8 6.2L	VO-88	VA-223		NS ⁴³⁷
V8 6.7L Diesel Turbo	VO-104	VA-266		
V10 6.8L	VO-88	VA-223		NS ⁴³⁷

Police Interceptor Sedan

4 cyl. 2.0L (9) Turbo	VO-25	VA-224	VCA-1118	NS ⁴³⁷
V6 3.5L (8) Non turbo	VO-88	VA-224	VCA-1118	NS ⁴³⁷
V6 3.5L (T) Turbo	VO-88	VA-224	VCA-1118	NS ⁴³⁷
V6 3.7L (K)	VO-88	VA-224	VCA-1118	NS ⁴³⁷

Police Interceptor Utility

V6 3.5L (T) Turbo	VO-88	VA-224	VCA-1118	NS ⁴³⁷
V6 3.7L (R)	VO-88	VA-224	VCA-1118	NS ⁴³⁷

Taurus

4 cyl. 2.0L	VO-25	VA-224	VCA-1118	NS ⁴³⁷
V6 3.5L Non turbo	VO-88	VA-224	VCA-1118	NS ⁴³⁷
V6 3.5L Turbo	VO-88	VA-224	VCA-1118	NS ⁴³⁷

Transit Connect

4 cyl. 1.6L Turbo	VO-25	VA-288	VCA-1081	NS ⁴³⁷
4 cyl. 2.5L	VO-25	VA-298	VCA-1081	NS ⁴³⁷

2013

C-MAX

4 cyl. 2.0L Hybrid	VO-25	VA-429	VCA-1081	NS ⁴³⁷
--------------------	-------	--------	----------	-------------------

Econoline

V8 4.6L (Flex Fuel)	VO-88	VA-94		NS ⁴³⁷
V8 5.4L	VO-88	VA-94		NS ⁴³⁷
V8 5.4L (CNG/LPG)	VO-88	VA-94		
V10 6.8L	VO-88	VA-94		NS ⁴³⁷
V10 6.8L (CNG/LPG)	VO-88	VA-94		

Edge

4 cyl. 2.0L	VO-25	VA-224	VCA-1049	NS ⁴³⁷
V6 3.5L	VO-88	VA-224	VCA-1049	NS ⁴³⁷
V6 3.7L	VO-88	VA-224	VCA-1049	NS ⁴³⁷

Escape

4 cyl 1.6L	VO-25	VA-288	VCA-1081	NS ⁴³⁷
4 cyl 2.0L	VO-25	VA-288	VCA-1081	NS ⁴³⁷
4 cyl 2.5L	VO-25	VA-298	VCA-1081	NS ⁴³⁷

Expedition

V8 5.4L (Flex Fuel)	VO-88	VA-223		NS ⁴³⁷
---------------------	-------	--------	--	-------------------

Se reporter à table de matière pour les notes en bas de page en français. Utilize el contenido para ver notas a pie.

NS - Non-Serviceable / Non réparable / No reparable LF - Life-Time Filter / Filtro para toda la vida / Filtre à vie

⁴³⁷ Requires replacement of the complete fuel pump/fuel filter module.



FORD (cont'd)

	Oil	Air	Cabin*	Fuel
2013				
Explorer				
4 cyl. 2.0L Turbo	VO-25	VA-224	VCA-1118	NS ⁴³⁷
V6 3.5L Non turbo	VO-88	VA-224	VCA-1118	NS ⁴³⁷
V6 3.5L Turbo	VO-88	VA-224	VCA-1118	NS ⁴³⁷
F53				
V10 6.8	VO-88	VA-382		NS ⁴³⁷
F59				
V10 6.8	VO-88	VA-223		
Fiesta				
4 cyl. 1.6L	VO-25	VA-284	VCA-1177	NS ⁴³⁷
Flex				
V6 3.5L (8) Non turbo	VO-88	VA-224	VCA-1118	NS ⁴³⁷
V6 3.5L (T) Turbo	VO-88	VA-224	VCA-1118	NS ⁴³⁷
Focus				
Electric			VCA-1081	
4 cyl. 2.0L (2)	VO-25	VA-288	VCA-1081	NS ⁴³⁷
4 cyl. 2.0L Turbo	VO-25	VA-288	VCA-1081	NS ⁴³⁷
Fusion				
4 cyl. 1.6L Turbo	VO-25	VA-306	VCA-1174	NS ⁴³⁷
4 cyl. 2.0L Hybrid	VO-25	VA-429	VCA-1174	NS ⁴³⁷
4 cyl. 2.0L Turbo	VO-25	VA-306	VCA-1174	NS ⁴³⁷
4 cyl. 2.5L	VO-25	VA-306	VCA-1174	NS ⁴³⁷
Mustang				
V6 3.7L	VO-88	VA-253	VCA-1102	
V8 5.0L	VO-88	VA-253	VCA-1102	
V8 5.8L Supercharged	VO-88		VCA-1102	
Pickup F Series				
V6 3.5L Turbo	VO-88	VA-223		NS ⁴³⁷
V6 3.7L	VO-88	VA-223		NS ⁴³⁷
V8 5.0L	VO-88	VA-223		NS ⁴³⁷
V8 6.2L	VO-88	VA-223		NS ⁴³⁷
Pickup F250-F550 Super Duty				
V8 6.2L	VO-88	VA-223		NS ⁴³⁷
V8 6.7L Diesel Turbo	VO-104	VA-266		
V10 6.8L	VO-88	VA-223		NS ⁴³⁷
Police Interceptor Sedan				
V6 3.5L (8) Non turbo	VO-88	VA-224	VCA-1118	NS ⁴³⁷
V6 3.5L (T) Turbo	VO-88	VA-224	VCA-1118	NS ⁴³⁷
V6 3.7L (K)	VO-88	VA-224	VCA-1118	NS ⁴³⁷
Police Interceptor Utility				
V6 3.7L (R)	VO-88	VA-224	VCA-1118	NS ⁴³⁷
Taurus				
4 cyl. 2.0L	VO-25	VA-224	VCA-1118	NS ⁴³⁷
V6 3.5L Non turbo	VO-88	VA-224	VCA-1118	NS ⁴³⁷
V6 3.5L Turbo	VO-88	VA-224	VCA-1118	NS ⁴³⁷
Transit Connect				
4 cyl. 2.0L	VO-25	VA-267	VCA-1163	NS ⁴³⁷
2012				
Econoline				
V8 4.6L (Flex Fuel)	VO-88	VA-94		
V8 5.4L	VO-88	VA-94		
V8 5.4L (CNG/LPG)	VO-88	VA-94		
V10 6.8L	VO-88	VA-94		

Se reporter à table de matière pour les notes en bas de page en français. Utilize el contenido para ver notas a pie.

NS - Non-Serviceable / Non réparable / No reparable LF - Life-Time Filter / Filtro para toda la vida / Filtre à vie

⁴³⁷ Requires replacement of the complete fuel pump/fuel filter module.



FORD (cont'd)

2012

Econoline

V10 6.8L (CNG/LPG)	VO-88	VA-94		
--------------------	-------	-------	--	--

Edge

4 cyl. 2.0L	VO-25	VA-224	VCA-1049	NS ⁴³⁷
V6 3.5L	VO-88	VA-224	VCA-1049	NS ⁴³⁷
V6 3.7L	VO-88	VA-224	VCA-1049	NS ⁴³⁷

Escape

4 cyl 2.5L	VO-25	VA-149	VCA-1104	NS ⁴³⁷
4 cyl. 2.5L (Hybrid)	VO-25	VA-249	VCA-1104 ^{X909}	NS ⁴³⁷
			VCA-1101 ^{Z909}	
V6 3.0L	VO-88	VA-246	VCA-1104	NS ⁴³⁷

Expedition

V8 5.4L (Flex Fuel)	VO-88	VA-223		
---------------------	-------	--------	--	--

Explorer

4 cyl. 2.0L Turbo	VO-25	VA-224	VCA-1118	NS ⁴³⁷
V6 3.5L	VO-88	VA-224	VCA-1118	NS ⁴³⁷

F53

V10 6.8L	VO-88	VA-382		NS ⁴³⁷
----------	-------	--------	--	-------------------

F59

V10 6.8	VO-88	VA-223		
---------	-------	--------	--	--

Fiesta

4 cyl. 1.6L	VO-25	VA-284	VCA-1177	NS ⁴³⁷
-------------	-------	--------	----------	-------------------

Flex

V6 3.5L (C) Non turbo	VO-88	VA-224	VCA-1118	NS ⁴³⁷
V6 3.5L (T) Turbo	VO-88	VA-224	VCA-1118	NS ⁴³⁷

Focus

Electric			VCA-1081	
4 cyl. 2.0L	VO-25	VA-288	VCA-1081	NS ⁴³⁷

Fusion

4 cyl. 2.5L	VO-25	VA-215	VCA-1059	NS ⁴³⁷
4 cyl. 2.5L Hybrid	VO-25	LF ⁴⁵⁰	VCA-1059	NS ⁴³⁷
V6 3.0L (Flex Fuel)	VO-88	VA-216	VCA-1059	NS ⁴³⁷
V6 3.5L	VO-88	VA-224	VCA-1059	NS ⁴³⁷

Mustang

V6 3.7L	VO-88	VA-253	VCA-1102	
V8 5.0L	VO-88	VA-253	VCA-1102	
V8 5.4L Supercharged	VO-88		VCA-1102	

Pickup F Series

V6 3.5L Turbo	VO-88	VA-223		NS ⁴³⁷
V6 3.7L	VO-88	VA-223		NS ⁴³⁷
V8 5.0L	VO-88	VA-223		NS ⁴³⁷
V8 6.2L	VO-88	VA-223		NS ⁴³⁷

Pickup F250-F550 Super Duty

V8 6.2L	VO-88	VA-223		NS ⁴³⁷
V8 6.7L Diesel Turbo	VO-104	VA-266		
V10 6.8L (Y)	VO-88	VA-223		NS ⁴³⁷

Taurus

V6 3.5L Non turbo	VO-88	VA-224	VCA-1118	NS ⁴³⁷
V6 3.5L Turbo	VO-88	VA-224	VCA-1118	NS ⁴³⁷

Transit Connect

4 cyl. 2.0L	VO-25	VA-267	VCA-1163	NS ⁴³⁷
-------------	-------	--------	----------	-------------------

Se reporter à table de matière pour les notes en bas de page en français. Utilize el contenido para ver notas a pie.

NS - Non-Serviceable / Non réparable / No reparable LF - Life-Time Filter / Filtro para toda la vida / Filtro à vie

⁴³⁷ Requires replacement of the complete fuel pump/fuel filter module. ⁴⁵⁰ Lifetime filter. Does not require replacement under normal conditions. ^{X909}Dust filter

^{Z909}High Voltage battery pack on driver side rear cargo trim panel.



FORD (cont'd)

	Oil	Air	Cabin*	Fuel
2011				
Crown Victoria				
V8 4.6L (V) FI	VO-88 ^{X362} VO-25 ^{Z362}	VA-205		
Econoline				
V8 4.6L (W) (Flex Fuel)	VO-88	VA-94		
V8 5.4L	VO-88	VA-94		
V8 5.4L (CNG/LPG)	VO-88	VA-94		
V10 6.8L	VO-88	VA-94		
V10 6.8L (CNG/LPG)	VO-88	VA-94		
Edge				
V6 3.5L	VO-88	VA-224	VCA-1049	NS ⁴³⁷
V6 3.7L	VO-88	VA-224	VCA-1049	NS ⁴³⁷
Escape				
4 cyl. 2.5L	VO-25	VA-149	VCA-1104	NS ⁴³⁷
4 cyl. 2.5L (Hybrid)	VO-25	VA-249	VCA-1104 ^{X909} VCA-1101 ^{Z909}	NS ⁴³⁷
V6 3.0L	VO-88	VA-246	VCA-1104	NS ⁴³⁷
Expedition				
V8 5.4L (Flex Fuel)	VO-88	VA-223		
Explorer				
V6 3.5L (8) FI	VO-88	VA-224	VCA-1118	
F53				
V10 6.8L (Y) FI	VO-88	VA-382		NS ⁴³⁷
F59				
V10 6.8	VO-88	VA-223		
Fiesta				
4 cyl. 1.6L	VO-25	VA-284	VCA-1177	NS ⁴³⁷
Flex				
V6 3.5L (C) Non turbo	VO-88	VA-224	VCA-1118	NS ⁴³⁷
V6 3.5L (T) Turbo	VO-88	VA-224	VCA-1118	NS ⁴³⁷
Focus				
4 cyl. 2.0L	VO-25	VA-241		
Fusion				
4 cyl. 2.5L	VO-25	VA-215	VCA-1059	NS ⁴³⁷
4 cyl. 2.5L Hybrid	VO-25	LF ⁴⁵⁰	VCA-1059	NS ⁴³⁷
V6 3.0L (Flex Fuel)	VO-88	VA-216	VCA-1059	NS ⁴³⁷
V6 3.5L	VO-88	VA-224	VCA-1059	NS ⁴³⁷
Mustang				
V6 3.7L	VO-88	VA-253	VCA-1102	
V8 5.0L	VO-88	VA-253	VCA-1102	
V8 5.4L Supercharged	VO-88		VCA-1102	
Pickup F Series				
V6 3.5L Turbo	VO-88	VA-223		NS ⁴³⁷
V6 3.7L	VO-88	VA-223		NS ⁴³⁷
V8 5.0L	VO-88	VA-223		NS ⁴³⁷
V8 6.2L	VO-88	VA-223		NS ⁴³⁷
Pickup F250-F550 Super Duty				
V8 6.2L (6)	VO-88	VA-223		NS ⁴³⁷
V8 6.7L Diesel Turbo	VO-104	VA-266		
V10 6.8L	VO-88	VA-223		NS ⁴³⁷
Ranger				
4 cyl. 2.3L (D)	VO-25	VA-322		
V6 4.0L (E)	VO-88	VA-322		

Se reporter à table de matière pour les notes en bas de page en français. Utilize el contenido para ver notas a pie.

NS - Non-Serviceable / Non réparable / No reparable LF - Life-Time Filter / Filtro para toda la vida / Filtre à vie

⁴³⁷ Requires replacement of the complete fuel pump/fuel filter module. ⁴⁵⁰ Lifetime filter. Does not require replacement under normal conditions. ^{X362} Except police.

^{X909} Dust filter ^{Z362} Police. ^{Z909} High Voltage battery pack on driver side rear cargo trim panel.



FORD (cont'd)

2011

Taurus

V6 3.5L Non turbo	VO-88	VA-224	VCA-1118	NS ⁴³⁷
V6 3.5L Turbo	VO-88	VA-224	VCA-1118	NS ⁴³⁷

Transit Connect

4 cyl. 2.0L	VO-25	VA-267	VCA-1163	NS ⁴³⁷
-------------	-------	--------	----------	-------------------

2010

Crown Victoria

V8 4.6L (V) FI (Flex Fuel)	VO-88 ^{X362} VO-25 ^{Z362}	VA-205		
----------------------------	--	--------	--	--

Econoline

V8 4.6L (W) (Flex Fuel)	VO-88	VA-94		
V8 5.4L (L) (CNG/LPG)	VO-88	VA-94		
V8 5.4L (L) (Flex Fuel)	VO-88	VA-94		
V8 6.0L (P) Diesel Turbo	VO-81			
V10 6.8L (S)	VO-88	VA-94		

Edge

V6 3.5L	VO-88	VA-224	VCA-1049	NS ⁴³⁷
---------	-------	--------	----------	-------------------

Escape

4 cyl 2.5L	VO-25	VA-149	VCA-1104	NS ⁴³⁷
4 cyl. 2.5L (Hybrid)	VO-25	VA-249	VCA-1104 ^{X909} VCA-1101 ^{Z909}	NS ⁴³⁷
V6 3.0L	VO-88	VA-246	VCA-1104	NS ⁴³⁷

Expedition

V8 5.4L (Flex Fuel)	VO-88	VA-223		
---------------------	-------	--------	--	--

Explorer

V6 4.0L (E) FI	VO-88	VA-162		
V8 4.6L (8) FI	VO-88	VA-222		

Explorer Sport Trac

V6 4.0L (E,K) FI	VO-88	VA-162		
V8 4.6L (8) FI	VO-88	VA-222		

Flex

V6 3.5L (C) Non turbo	VO-88	VA-224	VCA-1118	NS ⁴³⁷
V6 3.5L (T) Turbo	VO-88	VA-224	VCA-1118	NS ⁴³⁷

Focus

4 cyl. 2.0L	VO-25	VA-241		
-------------	-------	--------	--	--

Fusion

4 cyl. 2.5L	VO-25	VA-215	VCA-1059	NS ⁴³⁷
4 cyl. 2.5L Hybrid	VO-25	LF ⁴⁵⁰	VCA-1059	NS ⁴³⁷
V6 3.0L (Flex Fuel)	VO-88	VA-216	VCA-1059	NS ⁴³⁷
V6 3.5L	VO-88	VA-224	VCA-1059	NS ⁴³⁷

Mustang

V6 4.0L (N) FI	VO-88	VA-186	VCA-1102	
V8 4.6L (H) FI	VO-88	VA-253	VCA-1102	
V8 5.4L (S) FI (S.C.)	VO-88		VCA-1102	

Pickup F Series

V8 4.6L (W) FI (16 valve)	VO-88	VA-223		NS ⁴³⁷
V8 4.6L (8) FI (24 Valve)	VO-88	VA-223		
V8 5.4L	VO-88	VA-223		NS ⁴³⁷
V8 6.2L	VO-88	VA-223		NS ⁴³⁷

Pickup F250-F550 Super Duty

V8 5.4L	VO-88	VA-223		
V8 6.4L Diesel Turbo	VO-81	VA-239		
V10 6.8L	VO-88	VA-223		

Se reporter à table de matière pour les notes en bas de page en français. Utilize el contenido para ver notas a pie.

NS - Non-Serviceable / Non réparable / No reparable LF - Life-Time Filter / Filtro para toda la vida / Filtre à vie

⁴³⁷ Requires replacement of the complete fuel pump/fuel filter module. ⁴⁵⁰ Lifetime filter. Does not require replacement under normal conditions. ^{X362} Except police.

^{X909} Dust filter ^{Z362} Police. ^{Z909} High Voltage battery pack on driver side rear cargo trim panel.



FORD (cont'd)

	Oil	Air	Cabin*	Fuel
2010				
Ranger				
4 cyl. 2.3L (D)	VO-25	VA-322		
V6 4.0L (E)	VO-88	VA-322		
Taurus				
V6 3.5L Non turbo	VO-88	VA-224	VCA-1118	NS ⁴³⁷
V6 3.5L Turbo	VO-88	VA-224	VCA-1118	NS ⁴³⁷
2009				
Crown Victoria				
V8 4.6L (V,W) FI	VO-88 ^{X484} VO-25 ^{Z484}	VA-205		
Econoline				
V8 4.6L (W) FI (Flex Fuel)	VO-88	VA-94		
V8 5.4L (L) FI	VO-88	VA-94		
V8 6.0L (P) Diesel Turbo	VO-81			
V10 6.8L (S) FI	VO-88	VA-94		
Edge				
V6 3.5L	VO-118 ^{X486} VO-88 ^{Z486}	VA-224	VCA-1049	NS ⁴³⁷
Escape				
4 cyl. 2.5L	VO-80 ^{X374} VO-25 ^{Z374}	VA-149	VCA-1104	NS ⁴³⁷
4 cyl. 2.5L (Hybrid)	VO-80 ^{X374} VO-25 ^{Z374}	VA-249	VCA-1104 ^{X909} VCA-1101 ^{Z909}	NS ⁴³⁷
V6 3.0L FI	VO-88	VA-246	VCA-1104	NS ⁴³⁷
Expedition				
V8 5.4L (Flex Fuel)	VO-88	VA-223		
Explorer				
V6 4.0L (E) FI	VO-88	VA-162		
V8 4.6L (8) FI	VO-88	VA-222		
Explorer Sport Trac				
V6 4.0L (E) FI	VO-88	VA-162		
V8 4.6L (8) FI	VO-88	VA-222		
F53				
V10 6.8L (Y) FI	VO-88	VA-382		
Flex				
V6 3.5L (C)	VO-118 ^{X486} VO-88 ^{Z486}	VA-224		NS ⁴³⁷
Focus				
4 cyl. 2.0L (N) FI	VO-25	VA-241		
Fusion				
4 cyl. 2.3L (Z) FI	VO-80	VA-215		NS ⁴³⁷
V6 3.0L FI	VO-88	VA-216		NS ⁴³⁷
Mustang				
V6 4.0L (N) FI	VO-88	VA-186	VCA-1102	
V8 4.6L (H) FI	VO-88	VA-186 ⁴⁴⁹	VCA-1102	
V8 5.4L (S) FI (S.C.)	VO-88		VCA-1102	
Pickup F Series				
V8 4.6L (W) FI (16 valve)	VO-88 ^{X102} VO-118 ^{Z102}	VA-223		
V8 4.6L (8) FI (24 Valve)	VO-88 ^{X102} VO-118 ^{Z102}	VA-223		
V8 5.4L (V)	VO-88	VA-223		

Se reporter à table de matière pour les notes en bas de page en français. Utilize el contenido para ver notas a pie.

NS - Non-Serviceable / Non réparable / No reparable LF - Life-Time Filter / Filtro para toda la vida / Filtre à vie

⁴³⁷ Requires replacement of the complete fuel pump/fuel filter module. ⁴⁴⁹ w/o cold air induction. ^{X102} 22mm threaded stud. ^{X374} Cartridge ^{X484} All except

Police package after 11/13/08. ^{X484} Before Production 1/16/09. ^{X909} Dust filter ^{Z102} 3/4 inch threaded stud. ^{Z374} Spin-on ^{Z484} With Police package after

11/13/08. ^{Z486} After Production 1/15/09. ^{Z909} High Voltage battery pack on driver side rear cargo trim panel.



FORD (cont'd)

2009

Pickup F250-F550 Super Duty

V8 5.4L	VO-88	VA-223		
V8 6.4L Diesel Turbo	VO-81	VA-239		
V10 6.8L	VO-88	VA-223		

Ranger

4 cyl. 2.3L (D) FI	VO-25	VA-322		
V6 4.0L (E) FI	VO-88	VA-322		

Taurus

V6 3.5L	VO-118 ^{X486} VO-88 ^{Z486}	VA-224		NS ⁴³⁷
---------	---	--------	--	-------------------

Taurus X

V6 3.5L (W) FI	VO-118 ^{X486} VO-88 ^{Z486}	VA-224		NS ⁴³⁷
----------------	---	--------	--	-------------------

2008

Crown Victoria

V8 4.6L (W) FI	VO-88	VA-205		
V8 4.6L (V) FI (Flex Fuel)	VO-88	VA-205		

Econoline

V8 4.6L (W) FI	VO-88	VA-94		
V8 5.4L (L) FI	VO-88	VA-94		
V8 6.0L (P) Diesel Turbo	VO-81			
V10 6.8L (S) FI	VO-88	VA-94		

Edge

V6 3.5L	VO-118	VA-224	VCA-1049	NS ⁴³⁷
---------	--------	--------	----------	-------------------

Escape

4 cyl. 2.3L (Hybrid)	VO-80	VA-249	VCA-1104 ^{X909} VCA-1101 ^{Z909}	VG-32
4 cyl. 2.3L (Z) FI	VO-25	VA-149	VCA-1104	VG-32
V6 3.0L	VO-88	VA-149	VCA-1104	VG-32

Expedition

V8 5.4L	VO-88	VA-223		
---------	-------	--------	--	--

Explorer

V6 4.0L (E) FI	VO-88	VA-162		
V8 4.6L (8) FI	VO-88	VA-222		

Explorer Sport Trac

V6 4.0L (K) FI	VO-88	VA-162		
V8 4.6L (8) FI	VO-88	VA-222		

F53

V10 6.8L (Y) FI	VO-88	VA-382		
-----------------	-------	--------	--	--

Focus

4 cyl. 2.0L (N) FI	VO-25	VA-241		
--------------------	-------	--------	--	--

Fusion

4 cyl. 2.3L (Z) FI	VO-80	VA-215		NS ⁴³⁷
V6 3.0L FI	VO-88	VA-216		NS ⁴³⁷

Mustang

V6 4.0L (N) FI	VO-88	VA-186	VCA-1102	
V8 4.6L (H) FI	VO-88	VA-186 ⁴⁴⁹	VCA-1102	
V8 5.4L (S) FI (S.C.)	VO-88		VCA-1102	

Pickup F Series

V6 4.2L (2) FI	VO-118	VA-94		
V8 4.6L (W) FI	VO-88 ^{X102} VO-118 ^{Z102}	VA-94		
V8 5.4L (5) FI	VO-88	VA-182		

Se reporter à table de matière pour les notes en bas de page en français. Utilize el contenido para ver notas a pie.

NS - Non-Serviceable / Non réparable / No reparable LF - Life-Time Filter / Filtro para toda la vida / Filtre à vie

⁴³⁷ Requires replacement of the complete fuel pump/fuel filter module. ⁴⁴⁹ w/o cold air induction. ^{X102}22mm threaded stud. ^{X486}Before Production 1/16/09.

^{X909}Dust filter ^{Z102}3/4 inch threaded stud. ^{Z486}After Production 1/15/09. ^{Z909}High Voltage battery pack on driver side rear cargo trim panel.



FORD (cont'd)

	Oil	Air	Cabin*	Fuel
2008				
Pickup F Series				
V8 5.4L (V) FI (Flex Fuel)	VO-88	VA-182		
Pickup F250-F550 Super Duty				
V8 5.4L	VO-88	VA-223		
V8 6.4L Diesel Turbo	VO-81	VA-239		
V10 6.8L	VO-88	VA-223		
Ranger				
4 cyl. 2.3L (D) FI	VO-25	VA-322		
V6 3.0L (U) FI	VO-118	VA-322		
V6 4.0L (E) FI	VO-88	VA-322		
Taurus				
V6 3.5L	VO-118	VA-224		NS ⁴³⁷
Taurus X				
V6 3.5L (W) FI	VO-118	VA-224		NS ⁴³⁷
2007				
Crown Victoria				
V8 4.6L (W) FI	VO-88	VA-205		
V8 4.6L (V) FI (Flex Fuel)	VO-88	VA-205		
Econoline				
V8 4.6L (W) FI	VO-88	VA-94		
V8 5.4L (L) FI	VO-88	VA-94		
V8 6.0L (P) Diesel Turbo	VO-81			
V10 6.8L (S) FI	VO-88	VA-94		
Edge				
V6 3.5L	VO-118	VA-224	VCA-1049	NS ⁴³⁷
Escape				
4 cyl. 2.3L (Z)	VO-25	VA-149	VCA-1020	VG-16
4 cyl. 2.3L (Hybrid)	VO-80	VA-249	VCA-1020 ^{X505} VCA-1101 ^{Z505}	VG-16
V6 3.0L	VO-88	VA-149	VCA-1020	VG-16
Expedition				
V8 5.4L	VO-88	VA-223		
Explorer				
V6 4.0L (E) FI	VO-88	VA-162		
V8 4.6L (8) FI	VO-88	VA-222		
Explorer Sport Trac				
V6 4.0L (K) FI	VO-88	VA-162		
V8 4.6L (8) FI	VO-88	VA-222		
F53				
V10 6.8L (Y) FI	VO-88	VA-382		
Five Hundred				
V6 3.0L FI	VO-88	VA-197		
Focus				
4 cyl. 2.0L (N) FI	VO-25			
4 cyl. 2.3L (Z) FI	VO-25			
Freestar				
V6 3.9L (6) FI	VO-118	VA-142	VCA-1008	
V6 4.2L (2) FI	VO-118	VA-142	VCA-1008	
Freestyle				
V6 3.0L FI	VO-88	VA-197		
Fusion				
4 cyl. 2.3L (Z) FI	VO-80	VA-215		NS ⁴³⁷

Se reporter à table de matière pour les notes en bas de page en français. Utilize el contenido para ver notas a pie.

NS - Non-Serviceable / Non réparable / No repairable LF - Life-Time Filter / Filtro para toda la vida / Filtre à vie

⁴³⁷ Requires replacement of the complete fuel pump/fuel filter module. ^{X505}Dust filter. ^{Z505}For High Voltage battery pack on driver side rear cargo trim panel.



FORD (cont'd)

2007

Fusion

V6 3.0L FI	VO-88	VA-216		NS ⁴³⁷
------------	-------	--------	--	-------------------

Mustang

V6 4.0L (N) FI	VO-88	VA-186	VCA-1102	
V8 4.6L (H) FI	VO-88	VA-186	VCA-1102	
V8 5.4L (S) FI (S.C.)	VO-88		VCA-1102	

Pickup F Series

V6 4.2L (2) FI	VO-118	VA-94		
V8 4.6L (W) FI	VO-88 ^{X102}			
	VO-118 ^{Z102}	VA-94		
V8 5.4L (5) FI	VO-88	VA-182		
V8 5.4L (V) FI (Flex Fuel)	VO-88	VA-182		

Pickup F250-F550 Super Duty

V8 5.4L (5)	VO-88	VA-182		
V8 6.0L Diesel Turbo	VO-81	VA-174 ²²¹		
V10 6.8L (Y)	VO-88	VA-382		

Ranger

4 cyl. 2.3L (D) FI	VO-25	VA-322		
V6 3.0L (U) FI	VO-118	VA-322		
V6 4.0L (E) FI	VO-88	VA-322		

Taurus

V6 3.0L	VO-118	VA-149	VCA-1001	
---------	--------	--------	----------	--

2006

Crown Victoria

V8 4.6L (W) FI	VO-88	VA-205		
V8 4.6L (V) FI (Flex Fuel)	VO-88	VA-205		

Econoline

V8 4.6L (W) FI	VO-88	VA-94		
V8 5.4L (L) FI	VO-88	VA-94		
V8 6.0L (P) Diesel Turbo	VO-81			
V10 6.8L (S) FI	VO-88	VA-94		

Escape

4 cyl. 2.3L (Z)	VO-25	VA-149	VCA-1020	VG-16
4 cyl. 2.3L (Hybrid)	VO-80	VA-249	VCA-1020 ^{X505}	VG-16
			VCA-1101 ^{Z505}	
V6 3.0L	VO-88	VA-149	VCA-1020	VG-16

Expedition

V8 5.4L	VO-88	VA-182		
---------	-------	--------	--	--

Explorer

V6 4.0L (E) FI	VO-88	VA-162		
V8 4.6L (8) FI	VO-88	VA-222		

F53

V10 6.8L (Y) FI	VO-88	VA-382		
-----------------	-------	--------	--	--

Five Hundred

V6 3.0L FI	VO-88	VA-197		
------------	-------	--------	--	--

Focus

4 cyl. 2.0L (N) FI	VO-25			
4 cyl. 2.3L (Z) FI	VO-25			

Freestar

V6 3.9L (6) FI	VO-118	VA-142	VCA-1008	
V6 4.2L (2) FI	VO-118	VA-142	VCA-1008	

Freestyle

V6 3.0L FI	VO-88	VA-197		
------------	-------	--------	--	--

Se reporter à table de matière pour les notes en bas de page en français. Utilize el contenido para ver notas a pie.

NS - Non-Serviceable / Non réparable / No reparable LF - Life-Time Filter / Filtro para toda la vida / Filtre à vie

²²¹ OEM replacement filter. ⁴³⁷ Requires replacement of the complete fuel pump/fuel filter module. ^{X102}22mm threaded stud. ^{X505}Dust filter. ^{Z102}3/4 inch threaded stud. ^{Z505}For High Voltage battery pack on driver side rear cargo trim panel.



FORD (cont'd)

	Oil	Air	Cabin*	Fuel
2006				
Fusion				
4 cyl 2.3L (Z) FI	VO-80	VA-215		NS ⁴³⁷
V6 3.0L FI	VO-88	VA-216		NS ⁴³⁷
Mustang				
V6 4.0L (N) FI	VO-88	VA-186	VCA-1102	
V8 4.6L (H) FI	VO-88	VA-186	VCA-1102	
Pickup F Series				
V6 4.2L (2) FI	VO-118	VA-94		
V8 4.6L (W) FI	VO-88 ^{X102}	VA-94		
	VO-118 ^{Z102}	VA-94		
V8 5.4L (5) FI	VO-88	VA-182		
V8 5.4L (V) FI (Flex Fuel)	VO-88	VA-182		
Pickup F250-F550 Super Duty				
V8 5.4L (5)	VO-88	VA-182		
V8 6.0L Diesel Turbo	VO-81	VA-174 ²²¹		
V10 6.8L (Y)	VO-88	VA-382		
Ranger				
4 cyl. 2.3L (D) FI	VO-25	VA-322		
V6 3.0L (U) FI	VO-118	VA-322		
V6 4.0L (E) FI	VO-88	VA-322		
Taurus				
V6 3.0L	VO-118	VA-149	VCA-1001	
2005				
Crown Victoria				
V8 4.6L (W) FI	VO-88	VA-205		
V8 4.6L (9) FI (CNG)	VO-88	VA-205		
Econoline				
V8 4.6L (W) FI	VO-88	VA-94		
V8 5.4L (L) FI	VO-88	VA-94		
V8 5.4L (M) FI (CNG)	VO-88	VA-94		
V8 6.0L (P) Diesel Turbo	VO-81			
V10 6.8L (S) FI	VO-88	VA-94		
Escape				
4 cyl. 2.3L (Z)	VO-25	VA-149	VCA-1020	VG-16
4 cyl. 2.3L (Hybrid)	VO-80	VA-249	VCA-1020 ^{X505} VCA-1101 ^{Z505}	VG-16
V6 3.0L	VO-88	VA-149	VCA-1020	VG-16
Excursion				
V8 5.4L (L) FI	VO-88	VA-94		VG-32
V8 6.0L (P) Diesel Turbo	VO-81	VA-174 ²²¹		
V10 6.8L (S) FI	VO-88	VA-94		VG-32
Expedition				
V8 5.4L	VO-88	VA-182		
Explorer				
V6 4.0L (E) FI	VO-88	VA-162		
V6 4.0L (K) FI (Flex Fuel)	VO-88	VA-162		
V8 4.6L (W) FI	VO-88	VA-162		
Explorer Sport Trac				
V6 4.0L (E) FI	VO-88	VA-322		
V6 4.0L (K) FI (Flex Fuel)	VO-88	VA-322		
Five Hundred				
V6 3.0L FI	VO-88	VA-197		

Se reporter à table de matière pour les notes en bas de page en français. Utilize el contenido para ver notas a pie.

NS - Non-Serviceable / Non réparable / No repairable LF - Life-Time Filter / Filtro para toda la vida / Filtre à vie

²²¹ OEM replacement filter. ⁴³⁷ Requires replacement of the complete fuel pump/fuel filter module. ^{X102} 22mm threaded stud. ^{X505} Dust filter. ^{Z102} 3/4 inch threaded stud. ^{Z505} For High Voltage battery pack on driver side rear cargo trim panel.



FORD (cont'd)

2005

Focus

4 cyl. 2.0L (N) FI	VO-25			
4 cyl. 2.3L (Z) FI	VO-25			

Freestar

V6 3.9L (6) FI	VO-118	VA-142	VCA-1008	
V6 4.2L (2) FI	VO-118	VA-142	VCA-1008	

Freestyle

V6 3.0L FI	VO-88	VA-197		
------------	-------	--------	--	--

Mustang

V6 4.0L FI	VO-88	VA-186	VCA-1102	
V8 4.6L FI	VO-88	VA-186	VCA-1102	

Pickup F Series

V6 4.2L (2) FI	VO-118	VA-94		
V8 4.6L (W) FI	VO-88 ^{X102}			
	VO-118 ^{Z102}	VA-94		
V8 5.4L (5) FI	VO-88	VA-182		

Pickup F250-F550 Super Duty

V8 5.4L (5)	VO-88	VA-182		
V8 6.0L Diesel Turbo	VO-81	VA-174 ²²¹		
V10 6.8L	VO-88	VA-382		

Ranger

4 cyl. 2.3L (D) FI	VO-118	VA-322		
V6 3.0L (U) FI	VO-118	VA-322		
V6 4.0L (E) FI	VO-88	VA-322		

Taurus

V6 3.0L (U) FI (12 Valve)	VO-118	VA-149	VCA-1001	
V6 3.0L (S) FI (24 Valve)	VO-88	VA-149	VCA-1001	
V6 3.0L (2) FI (Flex Fuel)	VO-118	VA-149	VCA-1001	

Thunderbird

V8 3.9L (A) FI	VO-86	VA-142	VCA-1125	
----------------	-------	--------	----------	--

2004

Crown Victoria

V8 4.6L (W) FI	VO-88	VA-205		
V8 4.6L (9) FI (CNG)	VO-88	VA-205		

Econoline

V8 4.6L (W) FI	VO-88	VA-94		
V8 5.4L (L) FI	VO-88	VA-94		
V8 5.4L (M) FI (CNG)	VO-88	VA-94		
V8 6.0L (P) Diesel Turbo	VO-81			
V10 6.8L (S) FI	VO-88	VA-94		

Escape

4 cyl. 2.0L	VO-118	VA-149	VCA-1020	VG-16
V6 3.0L	VO-88	VA-149	VCA-1020	VG-16

Excursion

V8 5.4L (L) FI	VO-88	VA-94		VG-32
V8 6.0L (P) Diesel Turbo	VO-81	VA-174 ²²¹		
V10 6.8L (S) FI	VO-88	VA-94		VG-32

Expedition

V8 4.6L (W) FI	VO-88	VA-94		
V8 5.4L (L) FI	VO-88	VA-94		

Explorer

V6 4.0L (E) FI	VO-88	VA-162		
V6 4.0L (K) FI (Flex Fuel)	VO-88	VA-162		

Se reporter à table de matière pour les notes en bas de page en français. Utilize el contenido para ver notas a pie.

NS - Non-Serviceable / Non réparable / No reparable LF - Life-Time Filter / Filtro para toda la vida / Filtre à vie

²²¹ OEM replacement filter. ^{X102} 22mm threaded stud. ^{Z102} 3/4 inch threaded stud.



FORD (cont'd)

	Oil	Air	Cabin*	Fuel
2004				
Explorer				
V8 4.6L (W) FI	VO-88	VA-162		
Explorer Sport Trac				
V6 4.0L (E) FI	VO-88	VA-322		
V6 4.0L (K) FI (Flex Fuel)	VO-88	VA-322		
F53				
V10 6.8L (S) FI	VO-88	VA-94		VG-32
Focus				
4 cyl. 2.0L (3,5) FI DOHC	VO-118	VA-140	VCA-1163	
4 cyl. 2.0L (P) FI SOHC	VO-118	VA-140	VCA-1163	
4 cyl. 2.3L FI	VO-25	NS ⁴⁵⁰	VCA-1163	
Freestar				
V6 3.9L (6) FI	VO-118	VA-142	VCA-1008	
V6 4.2L (2) FI	VO-118	VA-142	VCA-1008	
Mustang				
V6 3.8L (4) FI	VO-118	VA-89		
V6 3.9L (6) FI	VO-118	VA-89		
V8 4.6L (Y) FI (Cobra) (S.C.)	VO-88	VA-94		
V8 4.6L (R) FI DOHC (Mach 1)	VO-88	VA-94		
V8 4.6L (X) FI SOHC (GT)	VO-88	VA-94		
Pickup F Series (Heritage)				
V6 4.2L (2) FI	VO-118	VA-94		
V8 4.6L (W) FI	VO-88	VA-94		
V8 5.4L (M) (CNG)	VO-88	VA-94		
V8 5.4L (Z) FI (Bi-Fuel)	VO-88	VA-94		
Pickup F150 Lightning				
V8 5.4L (3) FI (S.C.)	VO-88			
Pickup F150 (New design)				
V8 4.6L (W) FI	VO-88 ^{X102}	VA-94		
	VO-118 ^{Z102}	VA-182		
V8 5.4L (5) FI	VO-88	VA-182		
Pickup F250-F550 Super Duty				
V8 5.4L (L)	VO-88	VA-94		VG-32
V8 6.0L (P) Diesel Turbo	VO-81	VA-174 ^{Z21}		
V10 6.8L (S)	VO-88	VA-94		VG-32
Ranger				
4 cyl. 2.3L (D) FI	VO-118	VA-322		
V6 3.0L (U) FI	VO-118	VA-322		
V6 3.0L (V) FI (Flex Fuel)	VO-118	VA-322		
V6 4.0L (E) FI	VO-88	VA-322		
Taurus				
V6 3.0L (U) FI (12 Valve)	VO-118	VA-149	VCA-1001	
V6 3.0L (S) FI (24 Valve)	VO-88	VA-149	VCA-1001	
V6 3.0L (2) FI (Flex Fuel)	VO-118	VA-149	VCA-1001	
Thunderbird				
V8 3.9L (A) FI	VO-86	VA-142	VCA-1125	
2003				
Crown Victoria				
V8 4.6L (W) FI	VO-88	VA-205		
V8 4.6L (9) FI (CNG)	VO-88	VA-205		
Econoline				
V6 4.2L (2) FI	VO-118	VA-94		
V8 4.6L (W) FI	VO-88	VA-94		

Se reporter à table de matière pour les notes en bas de page en français. Utilize el contenido para ver notas a pie.

NS - Non-Serviceable / Non réparable / No reparable LF - Life-Time Filter / Filtro para toda la vida / Filtre à vie

²²¹ OEM replacement filter. ⁴⁵⁰ Lifetime filter. Does not require replacement under normal conditions. ^{X102} 22mm threaded stud. ^{Z102} 3/4 inch threaded stud.



FORD (cont'd)

2003

Econoline

V8 5.4L (L) FI	VO-88	VA-94		
V8 5.4L (M) FI (CNG)	VO-88	VA-94		
V10 6.8L (S) FI	VO-88	VA-94		
V8 7.3L (F) DI Turbo Diesel	VO-63	VA-120 ¹¹²		

Escape

4 cyl. 2.0L	VO-118	VA-149	VCA-1020	VG-16
V6 3.0L	VO-88	VA-149	VCA-1020	VG-16

Escort

4 cyl. 2.0L FI	VO-118	VFAP-1643		
----------------	--------	-----------	--	--

Excursion

V8 5.4L (L) FI	VO-88	VA-94		VG-32
V8 6.0L Diesel Turbo	VO-81	VA-174 ²²¹		
V10 6.8L (S) FI	VO-88	VA-94		VG-32
V8 7.3L (F) DI Turbo Diesel	VO-63	VA-167		

Expedition

V8 4.6L (W) FI	VO-88	VA-94	VCA-1017 ⁵⁶¹	
V8 5.4L (L) FI	VO-88	VA-94	VCA-1017 ⁵⁶¹	

Explorer

V6 4.0L (K) FI (Flex Fuel)	VO-88	VA-162		
V6 4.0L (E) FI (Gas)	VO-88	VA-162		
V8 4.6L (W) FI	VO-88	VA-162		

Explorer Sport

V6 4.0L FI	VO-88	VA-322		
------------	-------	--------	--	--

Explorer Sport Trac

V6 4.0L (E) FI	VO-88	VA-322		
----------------	-------	--------	--	--

F53

V10 6.8L (S) FI	VO-88	VA-94		VG-32
-----------------	-------	-------	--	-------

Focus

4 cyl. 2.0L (3,5) FI DOHC	VO-118	VA-140	VCA-1163	
4 cyl. 2.0L (P) FI SOHC	VO-118	VA-140	VCA-1163	
4 cyl. 2.3L FI	VO-25	VA-140	VCA-1163	

Mustang

V6 3.8L (4) FI	VO-118	VA-89		
V8 4.6L (Y) FI (Cobra) (S.C.)	VO-88	VA-94		
V8 4.6L (R) FI DOHC (Mach 1)	VO-88	VA-94		
V8 4.6L (X) FI SOHC (GT)	VO-88	VA-94		

Pickup F Series

V6 4.2L (2) FI	VO-118	VA-94	VCA-1017 ⁵⁶¹	
V8 4.6L (6,W) FI	VO-88	VA-94	VCA-1017 ⁵⁶¹	
V8 5.4L (M) (CNG)	VO-88	VA-94	VCA-1017 ⁵⁶¹	
V8 5.4L (L) FI	VO-88	VA-94	VCA-1017 ⁵⁶¹	
V8 5.4L (Z) FI (Bi-Fuel)	VO-88	VA-94	VCA-1017 ⁵⁶¹	
V8 5.4L (3) FI (Harley Davidson)	VO-88		VCA-1017 ⁵⁶¹	
V8 5.4L (3) FI (Lightning)	VO-88		VCA-1017 ⁵⁶¹	

Pickup F250-F550 Super Duty

V8 5.4L (L) FI	VO-88	VA-94		VG-32
V8 6.0L Diesel Turbo	VO-81	VA-174 ²²¹		
V10 6.8L (S)	VO-88	VA-94		VG-32
V8 7.3L (F) Diesel Turbo	VO-63	VA-167		

Ranger

4 cyl. 2.3L (D) FI	VO-118	VA-260		
V6 3.0L (U) FI	VO-118	VA-260		

Se reporter à table de matière pour les notes en bas de page en français. Utilize el contenido para ver notas a pie.

NS - Non-Serviceable / Non réparable / No reparable LF - Life-Time Filter / Filtro para toda la vida / Filtre à vie

¹¹² Requires two (2). ²²¹ OEM replacement filter. ⁵⁶¹ Ford kit# F65Z-18D477AA must be installed



FORD (cont'd)

	Oil	Air	Cabin*	Fuel
2003				
Ranger				
V6 3.0L (V) FI (Flex Fuel)	VO-118	VA-260		
V6 4.0L (E) FI	VO-88	VA-260		
Taurus				
V6 3.0L (2) (Flex Fuel)	VO-118	VA-149	VCA-1001	
V6 3.0L (U) FI (12 Valve)	VO-118	VA-149	VCA-1001	
V6 3.0L (S) FI (24 Valve)	VO-88	VA-149	VCA-1001	
Thunderbird				
V8 3.9L (A) FI	VO-86	VA-142	VCA-1125	
Windstar				
V6 3.8L (4) FI	VO-118	VA-114	VCA-1008	
2002				
Crown Victoria				
V8 4.6L (W) FI	VO-88	VA-205		
V8 4.6L (9) FI (CNG)	VO-88	VA-205		
Econoline				
V6 4.2L (2) FI	VO-118	VA-94		VG-32 ⁶³
V8 4.6L (W) FI	VO-88	VA-94		VG-32 ⁶³
V8 5.4L (L) FI	VO-88	VA-94		VG-32 ⁶³
V8 5.4L (M) FI (CNG)	VO-88	VA-94		
V10 6.8L (S) FI	VO-88	VA-94		VG-32 ⁶³
V8 7.3L (F) DI Turbo Diesel	VO-63	VA-120 ¹¹²		
Escape				
4 cyl. 2.0L	VO-118	VA-149	VCA-1020	VG-16
V6 3.0L	VO-88	VA-149	VCA-1020	VG-16
Escort				
4 cyl. 2.0L (3) FI DOHC	VO-118	VFAP-1643		
4 cyl. 2.0L (P) FI SOHC	VO-118	VFAP-1643		
Excursion				
V8 5.4L (L) FI	VO-88	VA-94		VG-32
V10 6.8L (S) FI	VO-88	VA-94		VG-32
V8 7.3L (F) DI Turbo Diesel	VO-63	VA-167		
Expedition				
V8 4.6L (W) FI	VO-88	VA-94	VCA-1017 ⁵⁶¹	
V8 5.4L (L) FI	VO-88	VA-94	VCA-1017 ⁵⁶¹	
Explorer				
V6 4.0L (K) FI (Flex Fuel)	VO-88	VA-162		
V6 4.0L (E) FI (Gas)	VO-88	VA-162		
V8 4.6L (W) FI	VO-88	VA-162		
Explorer Sport				
V6 4.0L FI	VO-88	VA-260		
Explorer Sport Trac				
V6 4.0L (E) FI	VO-88	VA-260		
F53				
V10 6.8L (S) FI	VO-88	VA-94		VG-32
Focus				
4 cyl. 2.0L (3,5) FI DOHC	VO-118	VA-140	VCA-1163	
4 cyl. 2.0L (P) FI SOHC	VO-118	VA-140	VCA-1163	
Mustang				
V6 3.8L (4) FI	VO-118	VA-89		
V8 4.6L (X) FI (GT)	VO-88	VA-94		

Se reporter à table de matière pour les notes en bas de page en français. Utilize el contenido para ver notas a pie.

NS - Non-Serviceable / Non réparable / No reparable LF - Life-Time Filter / Filtro para toda la vida / Filtre à vie

⁶³ 3 inch O.D. ¹¹² Requires two (2). ⁵⁶¹ Ford kit# F65Z-18D477AA must be installed



FORD (cont'd)

2002

Pickup F Series

V6 4.2L (2) FI	VO-118	VA-94	VCA-1017 ⁵⁶¹	
V8 4.6L (6,W) FI	VO-88	VA-94	VCA-1017 ⁵⁶¹	
V8 5.4L (M) (CNG)	VO-88	VA-94	VCA-1017 ⁵⁶¹	
V8 5.4L (L) FI	VO-88	VA-94	VCA-1017 ⁵⁶¹	
V8 5.4L (Z) FI (Bi-Fuel)	VO-88	VA-94	VCA-1017 ⁵⁶¹	
V8 5.4L (3) FI (Harley Davidson)	VO-88		VCA-1017 ⁵⁶¹	
V8 5.4L (3) FI (Lightning)	VO-88		VCA-1017 ⁵⁶¹	

Pickup F250-F550 Super Duty

V8 5.4L (L)	VO-88	VA-94		VG-32
V10 6.8L (S)	VO-88	VA-94		VG-32
V8 7.3L Diesel Turbo	VO-63	VA-167		

Ranger

4 cyl. 2.3L (D) FI	VO-118	VA-260		
V6 3.0L (U) FI	VO-118	VA-260		
V6 3.0L (V) FI (Flex Fuel)	VO-118	VA-260		
V6 4.0L (E) FI	VO-88	VA-260		

Taurus

V6 3.0L (2) (Flex Fuel)	VO-118	VA-149	VCA-1001	
V6 3.0L (U) FI (12 Valve)	VO-118	VA-149	VCA-1001	
V6 3.0L (S) FI (24 Valve)	VO-88	VA-149	VCA-1001	

Thunderbird

V8 3.9L (A) FI	VO-86	VA-142	VCA-1125	
----------------	-------	--------	----------	--

Windstar

V6 3.8L (4) FI	VO-118	VA-114	VCA-1008	
----------------	--------	--------	----------	--

2001

Crown Victoria

V8 4.6L (W) FI	VO-88	VA-205		
V8 4.6L (9) FI (CNG)	VO-88	VA-205		

Econoline

V6 4.2L (2) FI	VO-118	VA-94		VG-32 ⁶³
V8 4.6L (W) FI	VO-88	VA-94		VG-32 ⁶³
V8 5.4L (L) FI	VO-88	VA-94		VG-32 ⁶³
V8 5.4L (M) FI (CNG)	VO-88	VA-94		
V10 6.8L (S) FI	VO-88	VA-94		VG-32 ⁶³
V8 7.3L (F) DI Turbo Diesel	VO-63	VA-120 ¹¹²		

Escape

4 cyl. 2.0L	VO-118	VA-149	VCA-1020	VG-16
V6 3.0L	VO-88	VA-149	VCA-1020	VG-16

Escort

4 cyl. 2.0L (3) FI DOHC	VO-118	VFAP-1643		
4 cyl. 2.0L (P) FI SOHC	VO-118	VFAP-1643		

Excursion

V8 5.4L (L) FI	VO-88	VA-94		VG-32
V10 6.8L (S) FI	VO-88	VA-94		VG-32
V8 7.3L (F) DI Turbo Diesel	VO-63	VA-167		

Expedition

V8 4.6L (W) FI	VO-88	VA-94	VCA-1017 ⁵⁶¹	
V8 5.4L (L) FI	VO-88	VA-94	VCA-1017 ⁵⁶¹	

Explorer

V6 4.0L (E) FI	VO-1 ^{1502, X323} VO-88 ^{Z323}	VA-260		
----------------	---	--------	--	--

Se reporter à table de matière pour les notes en bas de page en français. Utilize el contenido para ver notas a pie.

NS - Non-Serviceable / Non réparable / No reparable LF - Life-Time Filter / Filtro para toda la vida / Filtre à vie

⁶³ 3 inch O.D. ¹¹² Requires two (2). ⁵⁶¹ Ford kit# F65Z-18D477AA must be installed ¹⁵⁰²Alternate. Primary VO-118 ^{X323}with 3/4 inch threaded stud.

^{Z323}with 22mm threaded stud.



FORD (cont'd)

	Oil	Air	Cabin*	Fuel
2001				
Explorer				
V6 4.0L (K) FI (Flex Fuel)	VO-1 ^{1502, X323} VO-88 ^{Z323}	VA-162		
V8 5.0L (P) FI	VO-88	VA-260		
Explorer Sport				
V6 4.0L FI	VO-1 ^{1502, X323} VO-88 ^{Z323}	VA-260		
Explorer Sport Trac				
V6 4.0L (E) FI	VO-1 ^{1502, X323} VO-88 ^{Z323}	VA-260		
F53				
V10 6.8L (S) FI	VO-88	VA-94		VG-32
Focus				
4 cyl. 2.0L (3) FI DOHC	VO-118	VA-140	VCA-1163	
4 cyl. 2.0L (P) FI SOHC	VO-118	VA-140	VCA-1163	
Mustang				
V6 3.8L (4) FI	VO-118	VA-89		
V8 4.6L (V) FI (Cobra)	VO-88	VA-94		
V8 4.6L (X) FI (GT)	VO-88	VA-94		
Pickup F Series				
V6 4.2L (2) FI	VO-118	VA-94	VCA-1017 ⁵⁶¹	
V8 4.6L (6,W) FI	VO-88	VA-94	VCA-1017 ⁵⁶¹	
V8 5.4L (M) (CNG)	VO-88	VA-94	VCA-1017 ⁵⁶¹	
V8 5.4L (L) FI	VO-88	VA-94	VCA-1017 ⁵⁶¹	
V8 5.4L (Z) FI (Bi-Fuel)	VO-88	VA-94	VCA-1017 ⁵⁶¹	
V8 5.4L (3) FI (Lightning)	VO-88	VA-94	VCA-1017 ⁵⁶¹	
Pickup F250-F550 Super Duty				
V8 5.4L (L)	VO-88	VA-94		VG-32
V10 6.8L (S)	VO-88	VA-94		VG-32
V8 7.3L Diesel Turbo	VO-63	VA-167		
Ranger				
4 cyl. 2.3L (D) FI	VO-118	VA-260		
4 cyl. 2.5L (C) FI	VO-118	VA-260		
V6 3.0L (U) FI	VO-118	VA-260		
V6 3.0L (V) FI (Flex Fuel)	VO-118	VA-260		
V6 4.0L (E) FI	VO-88	VA-260		
Taurus				
V6 3.0L (2) (Flex Fuel)	VO-118	VA-149	VCA-1001	
V6 3.0L (U) FI (12 Valve)	VO-118	VA-149	VCA-1001	
V6 3.0L (S) FI (24 Valve)	VO-88	VA-149	VCA-1001	
Windstar				
V6 3.8L (4) FI	VO-118	VA-114	VCA-1008	
2000				
Contour				
4 cyl. 2.0L (Z) FI (Bi-Fuel)(CNG)	VO-118	VFAP-1612	VCA-1157	
4 cyl. 2.0L (3) FI DOHC	VO-118	VFAP-1612	VCA-1157	VG-16
V6 2.5L (L) FI	VO-88	VFAP-1613	VCA-1157	VG-16
V6 2.5L (G) FI SVT	VO-88	VA-89	VCA-1157	VG-16
Crown Victoria				
V8 4.6L (W) FI	VO-88	VA-205		
V8 4.6L (9) FI (CNG)	VO-88	VA-205		
Econoline				
V6 4.2L (2) FI	VO-118	VA-94		VG-32

Se reporter à table de matière pour les notes en bas de page en français. Utilize el contenido para ver notas a pie.

NS - Non-Serviceable / Non réparable / No reparable LF - Life-Time Filter / Filtro para toda la vida / Filtre à vie

⁵⁶¹ Ford kit# F65Z-18D477AA must be installed ¹⁵⁰²Alternate. Primary VO-118 ^{X323}with 3/4 inch threaded stud. ^{Z323}with 22mm threaded stud.



FORD (cont'd)

2000

Econoline

V8 4.6L (W) FI	VO-88	VA-94		VG-32
V8 5.4L (L) FI	VO-88	VA-94		VG-32
V8 5.4L (M) FI (CNG)	VO-88	VA-94		
V10 6.8L (S) FI	VO-88	VA-94		VG-32
V8 7.3L (F) DI Turbo Diesel	VO-63	VA-120 ¹¹²		

Escort

4 cyl. 2.0L (3) FI DOHC	VO-118	VFAP-1643		
4 cyl. 2.0L (P) FI SOHC	VO-118	VFAP-1643		

Excursion

V8 5.4L (L) FI	VO-88	VA-94		VG-32
V10 6.8L (S) FI	VO-88	VA-94		VG-32
V8 7.3L (F) DI Turbo Diesel	VO-63	VA-122		

Expedition

V8 4.6L (W,6) FI	VO-88	VA-94	VCA-1017 ⁵⁶¹	
V8 5.4L (L) FI	VO-88	VA-94	VCA-1017 ⁵⁶¹	

Explorer

V6 4.0L (X) FI OHV	VO-1 ^{X502}			
	VO-118 ^{Z502}	VA-260		
V6 4.0L (E) FI SOHC	VO-1 ^{X502}			
	VO-118 ^{Z502}	VA-260		
V8 5.0L (P) FI	VO-88	VA-260		

F53

V10 6.8L (S) FI	VO-88	VA-94		VG-32
-----------------	-------	-------	--	-------

Focus

4 cyl. 2.0L (3) FI DOHC	VO-118	VA-140	VCA-1163	
4 cyl. 2.0L (P) FI SOHC	VO-118	VA-140	VCA-1163	

Mustang

V6 3.8L (4) FI	VO-118	VA-89		
V8 4.6L (X) FI (GT)	VO-88	VA-94		
V8 5.4L (H) FI (Cobra R)	VO-88	VA-94		

Pickup F Series

V6 4.2L (2) FI	VO-118	VA-94	VCA-1017 ⁵⁶¹	
V8 4.6L (6,W) FI	VO-88	VA-94	VCA-1017 ⁵⁶¹	
V8 5.4L (M) (CNG)	VO-88	VA-94	VCA-1017 ⁵⁶¹	
V8 5.4L (L) FI	VO-88	VA-94	VCA-1017 ⁵⁶¹	
V8 5.4L (Z) FI (Bi-Fuel)	VO-88	VA-94	VCA-1017 ⁵⁶¹	
V8 5.4L (3) FI (Lightning)	VO-88		VCA-1017 ⁵⁶¹	

Pickup F250-F550 Super Duty

V8 5.4L (L)	VO-88	VA-94		VG-32
V10 6.8L (S)	VO-88	VA-94		VG-32
V8 7.3L Diesel Turbo	VO-63	VA-122		

Ranger

4 cyl. 2.5L (C) FI	VO-118	VA-260		
V6 3.0L (U) FI	VO-118	VA-260		
V6 3.0L (V) FI (Flex Fuel)	VO-118	VA-260		
V6 4.0L (X) FI	VO-1 ^{X502}			
	VO-118 ^{Z502}	VA-260		

Taurus

V6 3.0L (2) (Flex Fuel)	VO-118	VA-149	VCA-1001	
V6 3.0L (U) FI (12 Valve)	VO-118	VA-149	VCA-1001	VG-16
V6 3.0L (S) FI (24 Valve)	VO-88	VA-149	VCA-1001	VG-16

Se reporter à table de matière pour les notes en bas de page en français. Utilize el contenido para ver notas a pie.

NS - Non-Serviceable / Non réparable / No reparable LF - Life-Time Filter / Filtro para toda la vida / Filtre à vie

¹¹² Requires two (2). ⁵⁶¹ Ford kit# F65Z-18D477AA must be installed ^{X502}Alternate ^{Z502}Primary



FORD (cont'd)

	Oil	Air	Cabin*	Fuel
2000				
Windstar				
V6 3.0L (U) FI	VO-118	VA-66	VCA-1008	
V6 3.8L (4) FI	VO-118	VA-114	VCA-1008	
1999				
Contour				
4 cyl. 2.0L (Z) FI (Bi-Fuel)(CNG)	VO-118	VFAP-1612	VCA-1157	
4 cyl. 2.0L (3) FI DOHC	VO-118	VFAP-1612	VCA-1157	VG-16
V6 2.5L (L) FI	VO-88	VFAP-1613	VCA-1157	VG-16
V6 2.5L (G) FI SVT	VO-88	VA-89	VCA-1157	VG-16
Crown Victoria				
V8 4.6L (W) FI	VO-88	VA-205		
V8 4.6L (9) FI (CNG)	VO-88	VA-205		
Econoline				
V6 4.2L (2) FI	VO-118	VA-94		VG-32
V8 4.6L (W,6) FI	VO-88	VA-94		VG-32
V8 5.4L (L) FI	VO-88	VA-94		VG-32
V8 5.4L (Z) FI (Bi-Fuel)	VO-88	VA-94		VG-32
V8 5.4L (M) FI (CNG)	VO-88	VA-94		VG-32
V10 6.8L (S) FI	VO-88	VA-94		VG-32
V8 7.3L (F) DI Turbo Diesel	VO-63	VA-120 ¹¹²		
Escort				
4 cyl. 2.0L (3) FI DOHC	VO-118	VFAP-1643		
4 cyl. 2.0L (P) FI SOHC	VO-118	VFAP-1643		
Expedition				
V8 4.6L (W,6) FI	VO-88	VA-94	VCA-1017 ⁵⁶¹	
V8 5.4L (L) FI	VO-88	VA-94	VCA-1017 ⁵⁶¹	
Explorer				
V6 4.0L (X) FI OHV	VO-1 ^{X502}			
	VO-118 ^{Z502}	VA-260		
V6 4.0L (E) FI SOHC	VO-1 ^{X502}			
	VO-118 ^{Z502}	VA-260		
V8 5.0L (P) FI	VO-88	VA-260		
F53				
V10 6.8L (S) FI	VO-88	VA-94		VG-32
Mustang				
V6 3.8L (4) FI	VO-118	VA-89		
V8 4.6L (V) FI (Cobra)	VO-88	VA-94		
V8 4.6L (X) FI (GT)	VO-88	VA-94		
Pickup F Series				
V6 4.2L (2) FI	VO-118	VA-94	VCA-1017 ⁵⁶¹	
V8 4.6L (6,W) FI	VO-88	VA-94	VCA-1017 ⁵⁶¹	
V8 5.4L (M) (CNG)	VO-88	VA-94	VCA-1017 ⁵⁶¹	
V8 5.4L (L) FI	VO-88	VA-94	VCA-1017 ⁵⁶¹	
V8 5.4L (Z) FI (Bi-Fuel)	VO-88	VA-94	VCA-1017 ⁵⁶¹	
V8 5.4L (3) FI (Lightning)	VO-88	VA-94	VCA-1017 ⁵⁶¹	
Pickup F250-F550 Super Duty				
V8 5.4L (L)	VO-88	VA-94		VG-32
V10 6.8L (S)	VO-88	VA-94		VG-32
V8 7.3L Diesel Turbo	VO-63	VA-122 ^{X403} VA-410 ^{Z403}		
Ranger				
4 cyl. 2.5L (C) FI	VO-118	VA-260		
V6 3.0L (U) FI	VO-118	VA-260		

Se reporter à table de matière pour les notes en bas de page en français. Utilize el contenido para ver notas a pie.

NS - Non-Serviceable / Non réparable / No reparable LF - Life-Time Filter / Filtro para toda la vida / Filtre à vie

¹¹² Requires two (2). ⁵⁶¹ Ford kit# F65Z-18D477AA must be installed ^{X403}After 12/98. ^{X502}Alternate ^{Z403}Before 12/98. ^{Z502}Primary



FORD (cont'd)

1999

Ranger

V6 3.0L (V) FI (Flex Fuel)	VO-118	VA-260		
V6 4.0L (X) FI	VO-1 ^{X502}			
	VO-118 ^{Z502}	VA-260		

Taurus

V6 3.0L (2) (Flex Fuel)	VO-118	VA-404	VCA-1001	
V6 3.0L (U) FI (12 Valve)	VO-118	VA-404	VCA-1001	VG-16
V6 3.0L (S) FI (24 Valve)	VO-88	VA-404	VCA-1001	VG-16
V8 3.4L (N) FI (SHO)	VO-118	VA-404	VCA-1001	VG-16

Windstar

V6 3.0L (U) FI	VO-118	VA-114	VCA-1008	
V6 3.8L (4) FI	VO-118	VA-114	VCA-1008	

1998

Contour

4 cyl. 2.0L (Z) FI (Bi-Fuel)(CNG)	VO-118	VFAP-1612	VCA-1157	
4 cyl. 2.0L (3) FI DOHC	VO-118	VFAP-1612	VCA-1157	VG-16
V6 2.5L (L) FI	VO-88	VFAP-1613	VCA-1157	VG-16
V6 2.5L (G) FI SVT	VO-88	VA-89	VCA-1157	VG-16

Crown Victoria

V8 4.6L (W) FI	VO-88	VA-205		
V8 4.6L (9) FI (CNG)	VO-88	VA-205		

Econoline

V6 4.2L (2) FI	VO-118	VA-94		VG-32
V8 4.6L (6) FI	VO-88	VA-94		VG-32
V8 5.4L (L) FI	VO-88	VA-94		VG-32
V8 5.4L (Z) FI (Bi-Fuel)	VO-88	VA-94		VG-32
V8 5.4L (M) FI (CNG)	VO-88	VA-94		
V10 6.8L (S) FI	VO-88	VA-94		VG-32
V8 7.3L (F) DI Turbo Diesel	VO-63	VA-120 ¹¹²		

Escort

4 cyl. 2.0L (3) FI DOHC	VO-118	VFAP-1643		
4 cyl. 2.0L (P) FI SOHC	VO-118	VFAP-1643		

Expedition

V8 4.6L (W,6) FI	VO-88	VA-94	VCA-1017 ⁵⁶¹	VG-32
V8 5.4L (L) FI	VO-88	VA-94	VCA-1017 ⁵⁶¹	VG-32

Explorer

V6 4.0L (X) FI OHV	VO-1 ^{X502}	VA-114 ^{X388}		VG-32
	VO-118 ^{Z502}	VFA-1641 ^{Z388}		
		VA-260 ^{Y388}		
V6 4.0L (E) FI SOHC	VO-1 ^{X502}	VA-260		VG-32
	VO-118 ^{Z502}	VA-260		VG-32
V8 5.0L (P) FI	VO-88	VA-260		VG-32

Mustang

V6 3.8L (4) FI	VO-118	VA-89		
V8 4.6L (V) FI (Cobra)	VO-88	VA-94		
V8 4.6L (X) FI (GT)	VO-88	VA-94		

Pickup F Series

V6 4.2L (2) FI	VO-118	VA-94	VCA-1017 ⁵⁶¹	VG-32
V8 4.6L (6,W) FI	VO-88	VA-94	VCA-1017 ⁵⁶¹	VG-32
V8 5.4L (L) FI	VO-88	VA-94	VCA-1017 ⁵⁶¹	VG-32
V8 5.4L (Z) FI (Bi-Fuel)	VO-88	VA-94	VCA-1017 ⁵⁶¹	VG-32
V8 5.4L (M) FI (CNG)	VO-88	VA-94	VCA-1017 ⁵⁶¹	

Se reporter à table de matière pour les notes en bas de page en français. Utilize el contenido para ver notas a pie.

NS - Non-Serviceable / Non réparable / No repairable LF - Life-Time Filter / Filtro para toda la vida / Filtre à vie

¹¹² Requires two (2). ⁵⁶¹ Ford kit# F65Z-18D477AA must be installed ^{X388}Conical air. ^{X502}Alternate ^{Y388}Panel air. ^{Z388}Conical air without dome.

^{Z502}Primary



FORD (cont'd)

	Oil	Air	Cabin*	Fuel
1998				
Ranger				
4 cyl. 2.5L (C) FI	VO-118	VA-260		
V6 3.0L (U) FI	VO-118	VA-260		
V6 4.0L (X) FI	VO-1 ^{X502} VO-118 ^{Z502}	VA-260		
Taurus				
V6 3.0L (S) FI (24 Valve)	VO-88	VA-404	VCA-1001	VG-16
V6 3.0L (1,2) FI Flex Fuel	VO-118	VA-404	VCA-1001	
V6 3.0L (U) FI Gas (12 Valve)	VO-118	VA-404	VCA-1001	VG-16
V8 3.4L (N) FI (SHO)	VO-118	VA-404	VCA-1001	VG-16
Windstar				
V6 3.0L (U) FI	VO-118	VA-66		VG-32
V6 3.8L (4) FI	VO-118	VA-114		VG-32
1997				
Aerostar				
V6 3.0L (U) FI	VO-118	VA-66		VG-16
V6 4.0L (X) FI	VO-1 ^{X502} VO-118 ^{Z502}	VA-66		VG-16
Aspire				
4 cyl. 1.3L (H) FI	VO-106			
Contour				
4 cyl. 2.0L (3) FI	VO-95	VFAP-1612	VCA-1157	VG-16
4 cyl. 2.0L (Z) FI (Bi-Fuel)(CNG)	VO-95	VFAP-1612	VCA-1157	
V6 2.5L (L) FI	VO-88	VFAP-1613	VCA-1157	VG-16
Crown Victoria				
V8 4.6L (W) FI	VO-88	VA-205		VG-16
V8 4.6L (9) FI (CNG)	VO-88	VA-205		
Econoline				
V6 4.2L (2) FI	VO-118	VA-94		VG-32
V8 4.6L (6) FI	VO-88	VA-94		VG-32
V8 5.4L (L) FI	VO-88	VA-94		VG-32
V8 5.4L (M) FI (CNG)	VO-88	VA-94		
V10 6.8L (S) FI	VO-88	VA-94		VG-32
V8 7.3L (F) DI Turbo Diesel	VO-63	VA-120 ¹¹²		
Escort				
4 cyl. 2.0L FI	VO-118	VFAP-1643		
Expedition				
V8 4.6L (W,6) FI	VO-88	VA-94	VCA-1017 ⁵⁶¹	VG-32
V8 5.4L (L) FI	VO-88	VA-94	VCA-1017 ⁵⁶¹	VG-32
Explorer				
V6 4.0L (X) FI OHV	VO-1 ^{X502} VO-118 ^{Z502}	VA-114 ^{X388} VFA-1641 ^{Z388} VA-260 ^{Y388}		VG-32
V6 4.0L (E) FI SOHC	VO-1 ^{X502} VO-118 ^{Z502}	VA-114 ^{X388} VFA-1641 ^{Z388} VA-260 ^{Y388}		VG-32
V8 5.0L (P) FI	VO-88	VA-114 ^{X388} VFA-1641 ^{Z388} VA-260 ^{Y388}		VG-32
F59				
V8 7.3L (M)	VO-46	VA-411		

Se reporter à table de matière pour les notes en bas de page en français. Utilize el contenido para ver notas a pie.

NS - Non-Serviceable / Non réparable / No reparable LF - Life-Time Filter / Filtro para toda la vida / Filtre à vie

¹¹² Requires two (2). ⁵⁶¹ Ford kit# F65Z-18D477AA must be installed ^{X388}Conical air. ^{X502}Alternate ^{Y388}Panel air. ^{Z388}Conical air without dome.

^{Z502}Primary



FORD (cont'd)

1997

F59

V8 7.3L (F) DI Turbo Diesel	VO-63	VA-93		
V8 7.3L (K) Diesel Turbo	VO-46			

Mustang

V6 3.8L (4) FI	VO-118	VA-89		VG-16
V8 4.6L (V) FI (Cobra)	VO-88	VA-94		VG-16
V8 4.6L (X) FI (GT)	VO-88	VA-94		VG-16

Pickup F Series

V6 4.2L (2) FI	VO-118	VA-94	VCA-1017 ⁵⁶¹	VG-32
V8 4.6L (6,W) FI	VO-88	VA-94	VCA-1017 ⁵⁶¹	VG-32
V8 5.4L (L) FI	VO-88	VA-94	VCA-1017 ⁵⁶¹	VG-32
V8 5.4L (M) FI (CNG)	VO-88	VA-94	VCA-1017 ⁵⁶¹	
V8 5.8L (H) FI	VO-88	VA-70	VCA-1017 ⁵⁶¹	VG-32
V8 7.3L Diesel Turbo	VO-63	VA-93	VCA-1017 ⁵⁶¹	
V8 7.5L (G) FI	VO-1 ^{X502} VO-118 ^{Z502}	VA-70	VCA-1017 ⁵⁶¹	VG-32

Probe

4 cyl. 2.0L (A) FI	VO-106	VA-106		
V6 2.5L (B) FI	VO-106	VA-106		

Ranger

4 cyl. 2.3L (A) FI	VO-1 ^{X502} VO-118 ^{Z502}	VA-114		VG-32
V6 3.0L (U) FI	VO-118	VA-114		VG-32
V6 4.0L (E,X) FI	VO-1 ^{X502} VO-118 ^{Z502}	VA-114 ^{X388} VFA-1641 ^{Z388} VA-260 ^{Y388}		VG-32

Taurus

V6 3.0L (U) FI (12 Valve)	VO-118	VA-404	VCA-1001	VG-16
V6 3.0L (S) FI (24 Valve)	VO-88	VA-404	VCA-1001	VG-16
V6 3.0L (1,2) FI Flex Fuel	VO-118	VA-404	VCA-1001	
V8 3.4L (N) FI SHO	VO-118	VA-404	VCA-1001	VG-16

Thunderbird

V6 3.8L (4) FI	VO-118	VA-88		
V8 4.6L (W) FI	VO-88	VA-88		

Windstar

V6 3.0L (U) FI	VO-118	VA-66		VG-32
V6 3.8L (4) FI	VO-118	VA-114		VG-32

1996

Aerostar

V6 3.0L (U) FI	VO-118	VA-66		VG-16
V6 4.0L (X) FI	VO-1 ^{X502} VO-118 ^{Z502}	VA-66		VG-16

Aspire

4 cyl. 1.3L (H) FI	VO-106			
--------------------	--------	--	--	--

Bronco

V8 5.0L (N) FI	VO-1 ^{X502} VO-118 ^{Z502}	VA-70		VG-32
V8 5.8L (H) FI	VO-88	VA-70		VG-32

Contour

4 cyl. 2.0L (3) FI	VO-95	VFAP-1612	VCA-1157	VG-16
4 cyl. 2.0L (Z) FI (Bi-Fuel)(CNG)	VO-95	VFAP-1612	VCA-1157	
V6 2.5L (L) FI	VO-88	VFAP-1613	VCA-1157	VG-16

Se reporter à table de matière pour les notes en bas de page en français. Utilize el contenido para ver notas a pie.

NS - Non-Serviceable / Non réparable / No reparable LF - Life-Time Filter / Filtro para toda la vida / Filtre à vie

⁵⁶¹Ford kit# F65Z-18D477AA must be installed ^{X388}Conical air. ^{X502}Alternate ^{Y388}Panel air. ^{Z388}Conical air without dome. ^{Z502}Primary



FORD (cont'd)

	Oil	Air	Cabin*	Fuel
1996				
Crown Victoria				
V8 4.6L (9) FI (CNG)	VO-88	VA-205		
V8 4.6L (W,6) FI GAS	VO-88	VA-205		VG-16
Econoline				
6 cyl. 4.9L (Y) FI	VO-1 ^{X502}			
	VO-118 ^{Z502}	VA-70		VG-32
6 cyl. 4.9L (Z) FI (Bi-Fuel)(CNG)	VO-1 ^{X502}			
	VO-118 ^{Z502}	VA-70		
V8 5.0L (N) FI	VO-1 ^{X502}			
	VO-118 ^{Z502}	VA-70		VG-32
V8 5.8L (H) FI	VO-1 ^{1502, X323}			
	VO-88 ^{Z323}	VA-70		VG-32
V8 7.3L (F) DI Turbo Diesel	VO-63	VA-120 ¹¹²		
V8 7.5L (G) FI	VO-1 ^{X502}			
	VO-118 ^{Z502}	VA-70		VG-32
Escort				
4 cyl. 1.8L (8) FI	VO-106	VA-416		VG-16
4 cyl. 1.9L (J) FI	VO-118	VA-69		VG-16
Explorer				
V6 4.0L (X) FI	VO-1 ^{X502}			
	VO-118 ^{Z502}	VA-114		VG-32
V8 5.0L (P) FI	VO-88	VA-114 ^{X388}		VG-32
		VFA-1641 ^{Z388}		
		VA-260 ^{Y388}		
F59				
V8 7.3L (M)	VO-46	VA-411		
V8 7.3L (F) DI Turbo Diesel	VO-63	VA-93		
V8 7.3L (K) Diesel Turbo	VO-46			
Mustang				
V6 3.8L (4) FI	VO-118	VA-89		VG-16
V8 4.6L (X) FI (16 valve)	VO-88	VA-94		VG-16
V8 4.6L (V) FI (32 Valve)	VO-88	VA-94		VG-16
Pickup F Series				
6 cyl. 4.9L (Y,Z) FI	VO-1 ^{X502}			
	VO-118 ^{Z502}	VA-70		VG-32
V8 5.0L (N) FI	VO-1 ^{X502}			
	VO-118 ^{Z502}	VA-70		VG-32
V8 5.8L (H) FI	VO-88	VA-70		VG-32
V8 7.3L Diesel Turbo	VO-63	VA-93		
V8 7.5L (G) FI	VO-1 ^{X502}			
	VO-118 ^{Z502}	VA-70		VG-32
Probe				
4 cyl. 2.0L (A) FI	VO-106	VA-106		
V6 2.5L (B) FI	VO-106	VA-106		
Ranger				
4 cyl. 2.3L (A) FI	VO-1 ^{X502}			
	VO-118 ^{Z502}	VA-114		VG-32
V6 3.0L (U) FI	VO-118	VA-114		VG-32
V6 4.0L (X) FI	VO-1 ^{X502}			
	VO-118 ^{Z502}	VA-114		VG-32
Taurus				
V6 3.0L (U) FI (12 Valve)	VO-118	VA-404	VCA-1001	VG-16
V6 3.0L (S) FI (24 Valve)	VO-88	VA-404	VCA-1001	VG-16

Se reporter à table de matière pour les notes en bas de page en français. Utilize el contenido para ver notas a pie.

NS - Non-Serviceable / Non réparable / No reparable LF - Life-Time Filter / Filtro para toda la vida / Filtre à vie

¹¹² Requires two (2). ¹⁵⁰²Alternate. Primary VO-118 ^{X323}with 3/4 inch threaded stud. ^{X388}Conical air. ^{X502}Alternate ^{Y388}Panel air. ^{Z323}with 22mm threaded stud. ^{Z388}Conical air without dome. ^{Z502}Primary



FORD (cont'd)

1996

Taurus

V6 3.0L (1) FI Flex Fuel	VO-118	VA-404	VCA-1001	
V8 3.4L (N) FI (SHO)	VO-118	VA-404	VCA-1001	VG-16

Thunderbird

V6 3.8L (4) FI	VO-118	VA-88		
V8 4.6L (W) FI	VO-88	VA-88		

Windstar

V6 3.0L (U) FI	VO-118	VA-66		VG-32
V6 3.8L (4) FI	VO-118	VA-114		VG-32

1995

Aerostar

V6 3.0L (U) FI	VO-118	VA-66		VG-16
V6 4.0L (X) FI	VO-1 ^{X502} VO-118 ^{Z502}	VA-66		VG-16

Aspire

4 cyl. 1.3L FI	VO-106			
----------------	--------	--	--	--

Bronco

V8 5.0L (N) FI	VO-1 ^{X502} VO-118 ^{Z502}	VA-70		VG-32
V8 5.8L (H) FI	VO-88	VA-70		VG-32

Contour

4 cyl. 2.0L FI	VO-95	VFAP-1612	VCA-1157	VG-16
V6 2.5L FI	VO-88	VFAP-1613	VCA-1157	VG-16

Crown Victoria

V8 4.6L (W) FI	VO-88	VA-205		VG-16
----------------	-------	--------	--	-------

Econoline

6 cyl. 4.9L (Y) FI	VO-1 ^{X502} VO-118 ^{Z502}	VA-70		VG-32
6 cyl. 4.9L (Z) FI (Bi-Fuel)(CNG)	VO-1 ^{X502} VO-118 ^{Z502}	VA-70		VG-32
V8 5.0L (N) FI	VO-1 ^{X502} VO-118 ^{Z502}	VA-70		VG-32
V8 5.8L (H) FI	VO-1 ^{X502} VO-118 ^{Z502}	VA-70		VG-32
V8 7.3L (F) DI Turbo Diesel	VO-63	VA-120 ¹¹²		VG-32
V8 7.5L (G) FI	VO-1 ^{X502} VO-118 ^{Z502}	VA-70		VG-32

Escort

4 cyl. 1.8L (8) FI	VO-106	VA-416		VG-16
4 cyl. 1.9L (J) FI	VO-118	VA-69		VG-16

Explorer

V6 4.0L (X) FI	VO-1 ^{X502} VO-118 ^{Z502}	VA-114		VG-32
----------------	--	--------	--	-------

F59

V8 7.3L (M)	VO-46	VA-411		
V8 7.3L (F) DI Turbo Diesel	VO-63	VA-93		
V8 7.3L (K) Diesel Turbo	VO-46			

Mustang

V6 3.8L (4) FI	VO-118	VA-89		VG-16
V8 5.0L (D) FI	VO-95 ^{X504} VO-25 ^{Z504}	VA-89		VG-16
V8 5.0L (T) FI	VO-1 ^{X502} VO-118 ^{Z502}	VA-89		VG-16

Se reporter à table de matière pour les notes en bas de page en français. Utilize el contenido para ver notas a pie.

NS - Non-Serviceable / Non réparable / No repairable LF - Life-Time Filter / Filtro para toda la vida / Filtre à vie

¹¹² Requires two (2). ^{X502}Alternate ^{X504}Alternate ^{Z502}Primary ^{Z504}Primary



FORD (cont'd)

1995				
Mustang				
V8 5.8L (C) FI	VO-95 ^{X504} VO-25 ^{Z504}	VA-89		VG-16
Mustang Cobra				
V8 5.0L (D) FI	VO-95 ^{X504} VO-25 ^{Z504}	VA-89		VG-16
Pickup F Series				
6 cyl. 4.9L (Y,Z) FI	VO-1 ^{X502} VO-118 ^{Z502}	VA-70		VG-32
V8 5.0L (N) FI	VO-1 ^{X502} VO-118 ^{Z502}	VA-70		VG-32
V8 5.8L (H) FI	VO-88	VA-70		VG-32
V8 5.8L (R) FI	VO-88	VA-70		VG-32
V8 7.3L (F) Diesel Turbo	VO-63	VA-93		VG-32
V8 7.5L (G) FI	VO-1 ^{X502} VO-118 ^{Z502}	VA-70		VG-32
Probe				
4 cyl. 2.0L (A) FI	VO-106	VA-106		
V6 2.5L (B) FI	VO-106	VA-106		
Ranger				
4 cyl. 2.3L (A)	VO-1 ^{X502} VO-118 ^{Z502}	VA-114		VG-32
V6 3.0L (U) FI	VO-118	VA-114		VG-32
V6 4.0L (X) FI	VO-1 ^{X502} VO-118 ^{Z502}	VA-114		VG-32
Taurus				
V6 3.0L (U) FI	VO-118	VA-66		VG-16
V6 3.0L (1) FI (Flex Fuel)	VO-118	VA-66		
V6 3.0L (Y) FI (SHO)	VO-118	VA-413		VG-16
V6 3.2L (P) FI (SHO)	VO-118	VA-413		VG-16
V6 3.8L (4) FI	VO-118	VA-66		VG-16
Thunderbird				
V6 3.8L (4) FI	VO-118	VA-88		
V6 3.8L (R) FI (S.C.)	VO-118	VA-88		
V8 4.6L (W) FI	VO-88	VA-88		
Windstar				
V6 3.0L (U) FI	VO-118	VA-66		VG-32
V6 3.8L (4)	VO-118	VA-66		VG-32
1994				
Crown Victoria				
V8 4.6L (W) FI	VO-88	VA-205		VG-16
Escort				
4 cyl. 1.8L (8) FI	VO-106	VA-416		VG-16
4 cyl. 1.9L (J) FI	VO-118	VA-69		VG-16
F59				
V8 7.3L (M)	VO-46	VA-411		
V8 7.3L (F) DI Turbo Diesel	VO-63	VA-93		
V8 7.3L (K) Diesel Turbo	VO-46			
Probe				
4 cyl. 2.0L (A) FI	VO-106	VA-106		
V6 2.5L (B) FI	VO-106	VA-106		
Thunderbird				
V8 4.6L (W) FI	VO-88	VA-88		

Se reporter à table de matière pour les notes en bas de page en français. Utilize el contenido para ver notas a pie.

NS - Non-Serviceable / Non réparable / No reparable LF - Life-Time Filter / Filtro para toda la vida / Filtre à vie

^{X502}Alternate ^{X504}Alternate ^{Z502}Primary ^{Z504}Primary



FREIGHTLINER

2018

Sprinter

V6 3.0L Diesel Turbo	VO-129	VA-349	VCA-1142	
----------------------	--------	--------	----------	--

2017

Sprinter

4 cyl. 2.1L Diesel Turbo		VA-349	VCA-1142	
V6 3.0L Diesel Turbo	VO-129	VA-349	VCA-1142	

2016

Sprinter

4 cyl. 2.1L Diesel Turbo		VA-349	VCA-1142	
V6 3.0L Diesel Turbo	VO-129	VA-349	VCA-1142	

2015

Sprinter

4 cyl. 2.1L Diesel Turbo		VA-349	VCA-1142	
V6 3.0L Diesel Turbo	VO-129	VA-349	VCA-1142	

2014

Sprinter

4 cyl. 2.1L Diesel Turbo		VA-349	VCA-1142	
V6 3.0L Diesel Turbo	VO-129	VA-349	VCA-1142	

2013

Sprinter

V6 3.0L Diesel Turbo	VO-129	VA-349	VCA-1142	
----------------------	--------	--------	----------	--

2012

Sprinter

V6 3.0L Diesel Turbo	VO-129	VA-349	VCA-1142	
----------------------	--------	--------	----------	--

2011

Sprinter

V6 3.0L Diesel Turbo	VO-129	VA-349	VCA-1142	
----------------------	--------	--------	----------	--

2010

Sprinter

V6 3.0L Diesel Turbo	VO-129	VA-349	VCA-1142	
----------------------	--------	--------	----------	--

2009

Sprinter

V6 3.0L Diesel Turbo	VO-129	VA-349	VCA-1142	
----------------------	--------	--------	----------	--

2008

Sprinter

V6 3.0L Diesel Turbo	VO-129	VA-349	VCA-1142	
V6 3.5L	VO-103	VA-349	VCA-1142	NS ⁴³⁷

2007

Sprinter

V6 3.0L Diesel Turbo	VO-129	VA-349	VCA-1142	
V6 3.5L	VO-103	VA-349	VCA-1142	NS ⁴³⁷

2006

Sprinter

5 cyl. 2.7L Diesel Turbo	VO-103	VA-380		
--------------------------	--------	--------	--	--

2005

Sprinter

5 cyl. 2.7L Diesel Turbo	VO-103	VA-380		
--------------------------	--------	--------	--	--

2004

Sprinter

5 cyl. 2.7L Diesel Turbo	VO-69	VA-380		
--------------------------	-------	--------	--	--

Se reporter à table de matière pour les notes en bas de page en français. Utilize el contenido para ver notas a pie.

NS - Non-Serviceable / Non réparable / No reparable LF - Life-Time Filter / Filtro para toda la vida / Filtre à vie

⁴³⁷ Requires replacement of the complete fuel pump/fuel filter module.



FREIGHTLINER (cont'd)

2003

Sprinter

5 cyl. 2.7L Diesel Turbo	VO-69	VA-380		
--------------------------	-------	--------	--	--

2002

Sprinter

5 cyl. 2.7L Diesel Turbo	VO-69	VA-380		
--------------------------	-------	--------	--	--

GENESIS

2019

G70

4 cyl. 2.0L Turbo	VO-106		VCA-1062	NS ⁴³⁷
-------------------	--------	--	----------	-------------------

V6 3.3L Turbo			VCA-1062	NS ⁴³⁷
---------------	--	--	----------	-------------------

G80

V6 3.3L Turbo			VCA-1062	NS ⁴³⁷
---------------	--	--	----------	-------------------

V6 3.8L	VO-167		VCA-1062	NS ⁴³⁷
---------	--------	--	----------	-------------------

V8 5.0L			VCA-1062	NS ⁴³⁷
---------	--	--	----------	-------------------

G90

V6 3.3L Turbo			VCA-1062	NS ⁴³⁷
---------------	--	--	----------	-------------------

V8 5.0L			VCA-1062	NS ⁴³⁷
---------	--	--	----------	-------------------

2018

G80

V6 3.3L Turbo			VCA-1062	NS ⁴³⁷
---------------	--	--	----------	-------------------

V6 3.8L	VO-167		VCA-1062	NS ⁴³⁷
---------	--------	--	----------	-------------------

V8 5.0L			VCA-1062	NS ⁴³⁷
---------	--	--	----------	-------------------

G90

V6 3.3L Turbo			VCA-1062	NS ⁴³⁷
---------------	--	--	----------	-------------------

V8 5.0L			VCA-1062	NS ⁴³⁷
---------	--	--	----------	-------------------

2017

G80

V6 3.8L	VO-167		VCA-1062	NS ⁴³⁷
---------	--------	--	----------	-------------------

V8 5.0L			VCA-1062	NS ⁴³⁷
---------	--	--	----------	-------------------

G90

V6 3.3L Turbo			VCA-1062	NS ⁴³⁷
---------------	--	--	----------	-------------------

V8 5.0L			VCA-1062	NS ⁴³⁷
---------	--	--	----------	-------------------

GEO

1997

Metro

3 cyl. 1.0L (6) FI	VO-25			
--------------------	-------	--	--	--

4 cyl. 1.3L (9) FI	VO-25			
--------------------	-------	--	--	--

Prizm

4 cyl. 1.6L (6) FI	VO-40			
--------------------	-------	--	--	--

4 cyl. 1.8L (8) FI	VO-40			
--------------------	-------	--	--	--

Tracker

4 cyl. 1.6L (6) FI	VO-25			
--------------------	-------	--	--	--

1996

Metro

3 cyl. 1.0L (6) FI	VO-25			
--------------------	-------	--	--	--

4 cyl. 1.3L (9) FI	VO-25			
--------------------	-------	--	--	--

Prizm

4 cyl. 1.6L (6) FI	VO-40			
--------------------	-------	--	--	--

4 cyl. 1.8L (8) FI	VO-40			
--------------------	-------	--	--	--

Tracker

4 cyl. 1.6L (6) FI	VO-25			
--------------------	-------	--	--	--

Se reporter à table de matière pour les notes en bas de page en français. Utilize el contenido para ver notas a pie.

NS - Non-Serviceable / Non réparable / No repairable LF - Life-Time Filter / Filtro para toda la vida / Filtre à vie

⁴³⁷ Requires replacement of the complete fuel pump/fuel filter module.



GEO (cont'd)

1995

Metro

3 cyl. 1.0L 61 (6) FI	VO-25			
4 cyl. 1.3L (9) FI	VO-25			

Prizm

4 cyl. 1.6L (6) FI	VO-40			
4 cyl. 1.8L (8) FI	VO-40			

Tracker

4 cyl. 1.6L (U) FI	VO-25			
4 cyl. 1.6L (6) FI (Calif.)	VO-25			

GMC

2019

Acadia

4 cyl. 2.5L	VO-200	VA-467	VCA-1184	NS ⁴³⁷
V6 3.6L	VO-201	VA-467	VCA-1184	NS ⁴³⁷

Canyon

4 cyl. 2.5L	VO-200	VA-425	VCA-1184	NS ⁴³⁷
4 cyl. 2.8L Diesel Turbo	VO-172	VA-425	VCA-1184	
V6 3.6L	VO-98	VA-425	VCA-1184	NS ⁴³⁷

Savana, Van

4 cyl. 2.8L Diesel Turbo		VA-485		
V6 4.3L	VO-88			NS ⁴³⁷
V8 6.0L	VO-88	VA-485		NS ⁴³⁷

Sierra 1500

4 cyl. 2.7L Turbo	VO-202	VA-505 ⁹³¹	VCA-1184 ^{X788} VCA-1183 ^{Z788}	NS ⁴³⁷
V6 4.3L	VO-88	VA-505 ⁹³¹	VCA-1184 ^{X788} VCA-1183 ^{Z788}	NS ⁴³⁷
V8 5.3	VO-88	VA-505 ⁹³¹	VCA-1184 ^{X788} VCA-1183 ^{Z788}	NS ⁴³⁷
V8 6.2L	VO-88	VA-505 ⁹³¹	VCA-1184 ^{X788} VCA-1183 ^{Z788}	NS ⁴³⁷

Sierra 2500HD, 3500HD

V8 6.0L	VO-88	VA-324	VCA-1173	NS ⁴³⁷
V8 6.6L Diesel Turbo	VO-75	VA-469	VCA-1173	

Sierra 1500 Limited

V8 5.3	VO-88	VA-324	VCA-1173	NS ⁴³⁷
--------	-------	--------	----------	-------------------

Terrain

4 cyl 1.5L Turbo	VO-160	VA-474	VCA-1184	NS ⁴³⁷
4 cyl 1.6L Diesel Turbo	VO-98	VA-474	VCA-1184	
4 cyl 2.0L Turbo	VO-160	VA-474	VCA-1184	NS ⁴³⁷

Yukon, Yukon XL

V8 5.3L	VO-88	VA-324	VCA-1173	NS ⁴³⁷
V8 6.2L	VO-88	VA-324	VCA-1173	NS ⁴³⁷

2018

Acadia

4 cyl. 2.5L	VO-200	VA-467	VCA-1184	NS ⁴³⁷
V6 3.6L	VO-201	VA-467	VCA-1184	NS ⁴³⁷

Canyon

4 cyl. 2.5L	VO-200	VA-425	VCA-1184	NS ⁴³⁷
4 cyl. 2.8L Diesel Turbo	VO-172	VA-425	VCA-1184	
V6 3.6L	VO-98	VA-425	VCA-1184	NS ⁴³⁷

Se reporter à table de matière pour les notes en bas de page en français. Utilize el contenido para ver notas a pie.

NS - Non-Serviceable / Non réparable / No reparable LF - Life-Time Filter / Filtro para toda la vida / Filtre à vie

⁴³⁷ Requires replacement of the complete fuel pump/fuel filter module. ⁹³¹ Standard service ^{X788}Dust ^{Z788}Dust and Odor



GMC (cont'd)

	Oil	Air	Cabin*	Fuel
2018				
Savana, Van				
4 cyl. 2.8L Diesel Turbo		VA-485		
V6 4.3L	VO-88			NS ⁴³⁷
V8 6.0L	VO-88	VA-485		NS ⁴³⁷
Sierra Pickup				
V6 4.3L	VO-88	VA-324	VCA-1173	NS ⁴³⁷
V8 5.3L (R) Hybrid	VO-88	VA-324	VCA-1173	NS ⁴³⁷
V8 5.3L Non Hybrid	VO-88	VA-324	VCA-1173	NS ⁴³⁷
V8 6.0L	VO-88	VA-324	VCA-1173	NS ⁴³⁷
V8 6.2L	VO-88	VA-324	VCA-1173	NS ⁴³⁷
V8 6.6L Diesel Turbo	VO-75	VA-469	VCA-1173	
Terrain				
4 cyl. 1.5L Turbo	VO-160	VA-474	VCA-1184	NS ⁴³⁷
4 cyl. 1.6L Diesel Turbo	VO-98	VA-474	VCA-1184	
4 cyl. 2.0L Turbo	VO-160	VA-474	VCA-1184	NS ⁴³⁷
Yukon, Yukon XL				
V8 5.3L	VO-88	VA-324	VCA-1173	NS ⁴³⁷
V8 6.2L	VO-88	VA-324	VCA-1173	NS ⁴³⁷
2017				
Acadia				
4 cyl. 2.5L	VO-200	VA-467	VCA-1184	NS ⁴³⁷
V6 3.6L	VO-201	VA-467	VCA-1184	NS ⁴³⁷
Acadia Limited				
V6 3.6L (D)	VO-88	VA-225	VCA-1080	NS ⁴³⁷
Canyon				
4 cyl. 2.5L	VO-200	VA-425	VCA-1184	NS ⁴³⁷
4 cyl. 2.8L Diesel Turbo	VO-172	VA-425	VCA-1184	
V6 3.6L	VO-98	VA-425	VCA-1184	NS ⁴³⁷
Savana, Van				
4 cyl. 2.8L Diesel Turbo		VA-485		
V8 4.8L (F) (Flex Fuel)	VO-88	VA-485		NS ⁴³⁷
V8 6.0L (G) (Flex Fuel)	VO-88	VA-485		NS ⁴³⁷
Sierra Pickup				
V6 4.3L	VO-88	VA-324	VCA-1173	NS ⁴³⁷
V8 5.3L Hybrid	VO-88	VA-324	VCA-1173	NS ⁴³⁷
V8 5.3L Non Hybrid	VO-88	VA-324	VCA-1173	NS ⁴³⁷
V8 6.0L	VO-88	VA-324	VCA-1173	NS ⁴³⁷
V8 6.2L	VO-88	VA-324	VCA-1173	NS ⁴³⁷
V8 6.6L Diesel Turbo	VO-75	VA-469	VCA-1173	
Terrain				
L4 2.4L	VO-76	VA-255	VCA-1075	NS ⁴³⁷
V6 3.6L	VO-88	VA-255	VCA-1075	NS ⁴³⁷
Yukon, Yukon XL				
V8 5.3L (Flex Fuel)	VO-88	VA-324	VCA-1173	NS ⁴³⁷
V8 6.2L (Flex Fuel)	VO-88	VA-324	VCA-1173	NS ⁴³⁷
2016				
Acadia				
V6 3.6L	VO-88	VA-225	VCA-1080	NS ⁴³⁷
Canyon				
4 cyl. 2.5L	VO-200	VA-425	VCA-1184	NS ⁴³⁷
4 cyl. 2.8L Diesel Turbo	VO-172	VA-425	VCA-1184	
V6 3.6L	VO-67	VA-425	VCA-1184	NS ⁴³⁷

Se reporter à table de matière pour les notes en bas de page en français. Utilize el contenido para ver notas a pie.

NS - Non-Serviceable / Non réparable / No reparable LF - Life-Time Filter / Filtro para toda la vida / Filtre à vie

⁴³⁷ Requires replacement of the complete fuel pump/fuel filter module.



GMC (cont'd)

2016

Savana, Van

V8 4.8L (F) (Flex Fuel)	VO-88	VA-169		NS ⁴³⁷
V8 6.0L (B) (CNG)	VO-88	VA-169		
V8 6.0L (G) (Flex Fuel)	VO-88	VA-169		NS ⁴³⁷
V8 6.6L (L) Diesel Turbo	VO-75	VA-381		

Sierra Pickup

V6 4.3L	VO-88	VA-259	VCA-1173	NS ⁴³⁷
V8 5.3L	VO-88	VA-259	VCA-1173	NS ⁴³⁷
V8 6.0L	VO-88	VA-259	VCA-1173	NS ⁴³⁷
V8 6.2L	VO-88	VA-259	VCA-1173	NS ⁴³⁷
V8 6.6L Diesel Turbo	VO-75	VA-295	VCA-1173	

Terrain

L4 2.4L	VO-76	VA-255	VCA-1075	NS ⁴³⁷
V6 3.6L	VO-88	VA-255	VCA-1075	NS ⁴³⁷

Yukon, Yukon XL

V8 5.3L (Flex Fuel)	VO-88	VA-259	VCA-1173	NS ⁴³⁷
V8 6.2L (Flex Fuel)	VO-88	VA-259	VCA-1173	NS ⁴³⁷

2015

Acadia

V6 3.6L	VO-88	VA-225	VCA-1080	NS ⁴³⁷
---------	-------	--------	----------	-------------------

Canyon

4 cyl. 2.5L	VO-200	VA-425	VCA-1184	NS ⁴³⁷
V6 3.6L	VO-67	VA-425	VCA-1184	NS ⁴³⁷

Savana, Van

V8 4.8L (F) (Flex Fuel)	VO-88	VA-169		NS ⁴³⁷
V8 6.0L (B) (CNG)	VO-88	VA-169		
V8 6.0L (G) (Flex Fuel)	VO-88	VA-169		NS ⁴³⁷
V8 6.6L (L) Diesel Turbo	VO-75	VA-381		

Sierra Pickup

V6 4.3L	VO-88	VA-259	VCA-1173	NS ⁴³⁷
V8 5.3L	VO-88	VA-259	VCA-1173	NS ⁴³⁷
V8 6.0L	VO-88	VA-259	VCA-1173	NS ⁴³⁷
V8 6.2L	VO-88	VA-259	VCA-1173	NS ⁴³⁷
V8 6.6L Diesel Turbo	VO-75	VA-295	VCA-1173	

Terrain

L4 2.4L	VO-76	VA-255	VCA-1075	NS ⁴³⁷
V6 3.6L	VO-88	VA-255	VCA-1075	NS ⁴³⁷

Yukon, Yukon XL

V8 5.3L (Flex Fuel)	VO-88	VA-259	VCA-1173	NS ⁴³⁷
V8 6.2L (Flex Fuel)	VO-88	VA-259	VCA-1173	NS ⁴³⁷

2014

Acadia

V6 3.6L	VO-88	VA-225	VCA-1080	NS ⁴³⁷
---------	-------	--------	----------	-------------------

Savana, Van

V6 4.3L (X)	VO-16	VA-169		NS ⁴³⁷
V8 4.8L (A) (Flex Fuel)	VO-88	VA-169		NS ⁴³⁷
V8 5.3L (4) (Flex Fuel)	VO-88	VA-169		NS ⁴³⁷
V8 6.0L (B) (CNG)	VO-88	VA-169		
V8 6.0L (G) (Flex Fuel)	VO-88	VA-169		NS ⁴³⁷
V8 6.6L (L) Diesel Turbo	VO-75	VA-381		

Sierra Pickup

V6 4.3L	VO-88	VA-259	VCA-1173	NS ⁴³⁷
V8 5.3L	VO-88	VA-259	VCA-1173	NS ⁴³⁷

Se reporter à table de matière pour les notes en bas de page en français. Utilize el contenido para ver notas a pie.

NS - Non-Serviceable / Non réparable / No reparable LF - Life-Time Filter / Filtro para toda la vida / Filtre à vie

⁴³⁷ Requires replacement of the complete fuel pump/fuel filter module.



GMC (cont'd)

	Oil	Air	Cabin*	Fuel
2014				
Sierra Pickup				
V8 6.0L (G)	VO-88	VA-259		NS ⁴³⁷
V8 6.0L (B) FI (CNG)	VO-88	VA-259		NS ⁴³⁷
V8 6.2L	VO-88	VA-259	VCA-1173	NS ⁴³⁷
V8 6.6L Diesel Turbo	VO-75	VA-295		
Terrain				
L4 2.4L	VO-76	VA-255	VCA-1075	NS ⁴³⁷
V6 3.6L	VO-88	VA-255	VCA-1075	NS ⁴³⁷
Yukon, Yukon XL				
V8 5.3L (0,7) FI (Flex Fuel)	VO-88	VA-259		NS ⁴³⁷
V8 6.2L (F) FI (Flex Fuel)	VO-88	VA-259		NS ⁴³⁷
2013				
Acadia				
V6 3.6L	VO-88	VA-225	VCA-1080	NS ⁴³⁷
Savana, Van				
V6 4.3L (X) FI	VO-16	VA-169		NS ⁴³⁷
V8 4.8L (A) FI (Flex Fuel)	VO-88	VA-169		NS ⁴³⁷
V8 5.3L (4) FI (Flex Fuel)	VO-88	VA-169		NS ⁴³⁷
V8 6.0L (B) FI (CNG)	VO-88	VA-169		
V8 6.0L (G) FI (Flex Fuel)	VO-88	VA-169		NS ⁴³⁷
V8 6.6L (L) Diesel Turbo	VO-75	VA-381		
Sierra Pickup				
V6 4.3L	VO-16	VA-259		NS ⁴³⁷
V8 4.8L (A)	VO-88	VA-259		NS ⁴³⁷
V8 5.3L	VO-88	VA-259		NS ⁴³⁷
V8 6.0L (J) (Hybrid)	VO-88	VA-259		NS ⁴³⁷
V8 6.0L (B,8) FI (CNG/LPG)	VO-88	VA-259		NS ⁴³⁷
V8 6.0L (G) FI (Gas or Flex)	VO-88	VA-259		NS ⁴³⁷
V8 6.2L (2)	VO-88	VA-259		NS ⁴³⁷
V8 6.6L (8,L) Diesel Turbo	VO-75	VA-295		
Terrain				
L4 2.4L	VO-76	VA-255	VCA-1075	NS ⁴³⁷
V6 3.6L	VO-88	VA-255	VCA-1075	NS ⁴³⁷
Yukon, Yukon XL				
V8 5.3L (0,7) FI (Flex Fuel)	VO-88	VA-259		NS ⁴³⁷
V8 6.0L (J) FI (Flex Fuel Hybrid)	VO-88	VA-259		NS ⁴³⁷
V8 6.0L (G) FI (Flex Fuel)	VO-88	VA-259		NS ⁴³⁷
V8 6.2L (2,F) FI (Flex Fuel)	VO-88	VA-259		NS ⁴³⁷
2012				
Acadia				
V6 3.6L	VO-88	VA-225	VCA-1080	NS ⁴³⁷
Canyon				
4 cyl. 2.9L	VO-58	VA-219		NS ⁴³⁷
5 cyl. 3.7L	VO-108	VA-219		NS ⁴³⁷
V8 5.3L	VO-88	VA-219		NS ⁴³⁷
Savana, Van				
V6 4.3L (X) FI	VO-16	VA-169		NS ⁴³⁷
V8 4.8L (A) FI (Flex Fuel)	VO-88	VA-169		NS ⁴³⁷
V8 5.3L (4) FI (Flex Fuel)	VO-88	VA-169		NS ⁴³⁷
V8 6.0L (B) FI (CNG)	VO-88	VA-169		
V8 6.0L (G) FI (Flex Fuel)	VO-88	VA-169		NS ⁴³⁷
V8 6.6L (L) Diesel Turbo	VO-75	VA-381		

Se reporter à table de matière pour les notes en bas de page en français. Utilize el contenido para ver notas a pie.

NS - Non-Serviceable / Non réparable / No reparable LF - Life-Time Filter / Filtro para toda la vida / Filtre à vie

⁴³⁷ Requires replacement of the complete fuel pump/fuel filter module.



GMC (cont'd)

2012

Sierra Pickup

V6 4.3L (X)	VO-16	VA-259		NS ⁴³⁷
V8 4.8L (A)	VO-88	VA-259		NS ⁴³⁷
V8 5.3L (0,7)	VO-88	VA-259		NS ⁴³⁷
V8 6.0L (G)	VO-88	VA-259		NS ⁴³⁷
V8 6.0L (J) (Hybrid)	VO-88	VA-259		NS ⁴³⁷
V8 6.2L (2)	VO-88	VA-259		NS ⁴³⁷
V8 6.6L (8,L) Diesel Turbo	VO-75	VA-295		

Terrain

L4 2.4L	VO-76	VA-255	VCA-1075	NS ⁴³⁷
V6 3.0L	VO-88	VA-255	VCA-1075	NS ⁴³⁷

Yukon, Yukon XL

V8 5.3L (7,0) FI (Flex Fuel)	VO-88	VA-259		NS ⁴³⁷
V8 6.0L (J) FI (Flex Fuel Hybrid)	VO-88	VA-259		NS ⁴³⁷
V8 6.0L (G) FI (Flex Fuel)	VO-88	VA-259		NS ⁴³⁷
V8 6.2L (2,F) FI (Flex Fuel)	VO-88	VA-259		NS ⁴³⁷

2011

Acadia

V6 3.6L	VO-88	VA-225	VCA-1080	NS ⁴³⁷
---------	-------	--------	----------	-------------------

Canyon

4 cyl. 2.9L	VO-58	VA-219		NS ⁴³⁷
5 cyl. 3.7L	VO-108	VA-219		NS ⁴³⁷
V8 5.3L	VO-88	VA-219		NS ⁴³⁷

Savana, Van

V6 4.3L (X) FI	VO-16	VA-169		NS ⁴³⁷
V8 4.8L (A) FI (Flex Fuel)	VO-88	VA-169		NS ⁴³⁷
V8 5.3L (4) FI (Flex Fuel)	VO-88	VA-169		NS ⁴³⁷
V8 6.0L (B) FI (CNG)	VO-88	VA-169		
V8 6.0L (G) FI (Flex Fuel)	VO-88	VA-169		NS ⁴³⁷
V8 6.6L (L) Diesel Turbo	VO-75	VA-381		

Sierra Pickup

V6 4.3L (X)	VO-16	VA-259		NS ⁴³⁷
V8 4.8L (A)	VO-88	VA-259		NS ⁴³⁷
V8 5.3L (0,3)	VO-88	VA-259		NS ⁴³⁷
V8 6.0L (G)	VO-88	VA-259		NS ⁴³⁷
V8 6.0L (J) (Hybrid)	VO-88	VA-259		NS ⁴³⁷
V8 6.2L (2)	VO-88	VA-259		NS ⁴³⁷
V8 6.6L (8,L) Diesel Turbo	VO-75	VA-295		

Terrain

L4 2.4L	VO-76	VA-255	VCA-1075	NS ⁴³⁷
V6 3.0L (Flex Fuel)	VO-88	VA-255	VCA-1075	NS ⁴³⁷

Yukon, Yukon XL

V8 5.3L (3,0) FI (Flex Fuel)	VO-88	VA-259		NS ⁴³⁷
V8 6.0L (J) FI (Flex Fuel Hybrid)	VO-88	VA-259		NS ⁴³⁷
V8 6.0L (G) FI (Flex Fuel)	VO-88	VA-259		NS ⁴³⁷
V8 6.2L (2,F) FI (Flex Fuel)	VO-88	VA-259		NS ⁴³⁷

2010

Acadia

V6 3.6L	VO-88	VA-225	VCA-1080	NS ⁴³⁷
---------	-------	--------	----------	-------------------

Canyon

4 cyl. 2.9L	VO-58	VA-219		NS ⁴³⁷
5 cyl. 3.7L	VO-108	VA-219		NS ⁴³⁷
V8 5.3L	VO-88	VA-219		NS ⁴³⁷

Se reporter à table de matière pour les notes en bas de page en français. Utilize el contenido para ver notas a pie.

NS - Non-Serviceable / Non réparable / No reparable LF - Life-Time Filter / Filtro para toda la vida / Filtre à vie

⁴³⁷ Requires replacement of the complete fuel pump/fuel filter module.



GMC (cont'd)

2010

Savana, Van

V6 4.3L (X) FI	VO-16	VA-169		NS ⁴³⁷
V8 4.8L (A) FI	VO-88	VA-169		NS ⁴³⁷
V8 5.3L (4) FI	VO-88	VA-169		NS ⁴³⁷
V8 6.0L (G) FI	VO-88	VA-169		NS ⁴³⁷
V8 6.6L (6,L) Diesel Turbo	VO-75	VA-381		

Sierra Pickup

V6 4.3L (X)	VO-16	VA-259		NS ⁴³⁷
V8 4.8L (A)	VO-88	VA-259		NS ⁴³⁷
V8 5.3L (0,3)	VO-88	VA-259		NS ⁴³⁷
V8 6.0L	VO-88	VA-259		NS ⁴³⁷
V8 6.0L (J) (Hybrid)	VO-88	VA-259		NS ⁴³⁷
V8 6.2L (2)	VO-88	VA-259		NS ⁴³⁷
V8 6.6L (6) Diesel Turbo	VO-75	VA-218		

Terrain

L4 2.4L	VO-76	VA-255	VCA-1075	NS ⁴³⁷
V6 3.0L	VO-88	VA-255	VCA-1075	NS ⁴³⁷

Yukon, Yukon XL

V8 5.3L (3,0) FI (Flex Fuel)	VO-88	VA-259		NS ⁴³⁷
V8 6.0L (J) FI (Flex Fuel Hybrid)	VO-88	VA-259		NS ⁴³⁷
V8 6.0L (G) FI (Flex Fuel)	VO-88	VA-259		NS ⁴³⁷
V8 6.2L (2,F) FI	VO-88	VA-259		NS ⁴³⁷

2009

Acadia

V6 3.6L	VO-88	VA-225	VCA-1080	NS ⁴³⁷
---------	-------	--------	----------	-------------------

Canyon

4 cyl. 2.9L (9) FI	VO-58	VA-219		NS ⁴³⁷
5 cyl. 3.7L (E) FI	VO-108	VA-219		NS ⁴³⁷
V8 5.3L (L) FI	VO-88	VA-219		NS ⁴³⁷

Envoy

6 cyl. 4.2L (S) FI	VO-108	VA-161		NS ⁴³⁷
V8 5.3L (M) FI	VO-88	VA-161		NS ⁴³⁷

Savana, Van

V6 4.3L (X) FI	VO-16	VA-169		NS ⁴³⁷
V8 4.8L (C) FI	VO-88	VA-169		NS ⁴³⁷
V8 5.3L (4) FI	VO-88	VA-169		NS ⁴³⁷
V8 6.0L (K) FI	VO-88	VA-169		NS ⁴³⁷
V8 6.6L (6) Diesel Turbo	VO-75	VA-381		

Sierra Pickup

V6 4.3L (X) FI	VO-16	VA-259		NS ⁴³⁷
V8 4.8L (C) FI	VO-88	VA-259		NS ⁴³⁷
V8 5.3L	VO-88	VA-259		NS ⁴³⁷
V8 6.0L (K,Y)	VO-88	VA-259		NS ⁴³⁷
V8 6.0L (5) (Hybrid)	VO-88	VA-259		NS ⁴³⁷
V8 6.2L (2)	VO-88	VA-259		NS ⁴³⁷
V8 6.6L (6) Diesel Turbo	VO-75	VA-218		

Yukon, Yukon XL

V8 4.8L (C) FI	VO-88	VA-259		NS ⁴³⁷
V8 5.3L (3,0) FI (Flex Fuel)	VO-88	VA-259		NS ⁴³⁷
V8 5.3L (J) FI GAS	VO-88	VA-259		NS ⁴³⁷
V8 6.0L (K,Y) FI	VO-88	VA-259		NS ⁴³⁷
V8 6.0L (5) FI (Hybrid)	VO-88	VA-259		NS ⁴³⁷
V8 6.2L (2) FI (Flex Fuel)	VO-88	VA-259		NS ⁴³⁷

Se reporter à table de matière pour les notes en bas de page en français. Utilize el contenido para ver notas a pie.

NS - Non-Serviceable / Non réparable / No repairable LF - Life-Time Filter / Filtro para toda la vida / Filtre à vie

⁴³⁷ Requires replacement of the complete fuel pump/fuel filter module.



GMC (cont'd)

2008

Acadia

V6 3.6L	VO-88	VA-225	VCA-1080	NS ⁴³⁷
---------	-------	--------	----------	-------------------

Canyon

4 cyl. 2.9L (9) FI	VO-58	VA-219		NS ⁴³⁷
--------------------	-------	--------	--	-------------------

5 cyl. 3.7L (E) FI	VO-108	VA-219		NS ⁴³⁷
--------------------	--------	--------	--	-------------------

Envoy

6 cyl. 4.2L (S) FI	VO-108	VA-161		NS ⁴³⁷
--------------------	--------	--------	--	-------------------

V8 5.3L (M) FI	VO-88	VA-161		NS ⁴³⁷
----------------	-------	--------	--	-------------------

Savana, Van

V6 4.3L (X) FI	VO-16	VA-169		NS ⁴³⁷
----------------	-------	--------	--	-------------------

V8 4.8L (C) FI	VO-88	VA-169		NS ⁴³⁷
----------------	-------	--------	--	-------------------

V8 5.3L (4) FI	VO-88	VA-169		NS ⁴³⁷
----------------	-------	--------	--	-------------------

V8 6.0L (K) FI	VO-88	VA-169		NS ⁴³⁷
----------------	-------	--------	--	-------------------

V8 6.6L (6) Diesel Turbo	VO-75	VA-381		
--------------------------	-------	--------	--	--

Sierra Pickup

V6 4.3L (X) FI	VO-16	VA-259		NS ⁴³⁷
----------------	-------	--------	--	-------------------

V8 4.8L (C) FI	VO-88	VA-259		NS ⁴³⁷
----------------	-------	--------	--	-------------------

V8 5.3L FI	VO-88	VA-259		NS ⁴³⁷
------------	-------	--------	--	-------------------

V8 6.0L (Y) FI	VO-88	VA-259		NS ⁴³⁷
----------------	-------	--------	--	-------------------

V8 6.0L (K) FI	VO-88	VA-259		NS ⁴³⁷
----------------	-------	--------	--	-------------------

V8 6.2L FI	VO-88	VA-259		NS ⁴³⁷
------------	-------	--------	--	-------------------

V8 6.6L (6) Diesel Turbo	VO-75	VA-218		
--------------------------	-------	--------	--	--

Yukon, Yukon XL

V8 4.8L (C) FI	VO-88	VA-259		NS ⁴³⁷
----------------	-------	--------	--	-------------------

V8 5.3L (3,0) FI (Flex Fuel)	VO-88	VA-259		NS ⁴³⁷
------------------------------	-------	--------	--	-------------------

V8 5.3L (J) FI GAS	VO-88	VA-259		NS ⁴³⁷
--------------------	-------	--------	--	-------------------

V8 6.0L (K,Y) FI	VO-88	VA-259		NS ⁴³⁷
------------------	-------	--------	--	-------------------

V8 6.0L (5) FI (Hybrid)	VO-88	VA-259		NS ⁴³⁷
-------------------------	-------	--------	--	-------------------

V8 6.2L (8) FI	VO-88	VA-259		NS ⁴³⁷
----------------	-------	--------	--	-------------------

2007

Acadia

V6 3.6L	VO-88	VA-225	VCA-1080	NS ⁴³⁷
---------	-------	--------	----------	-------------------

Canyon

4 cyl. 2.9L (9) FI	VO-58	VA-181		NS ⁴³⁷
--------------------	-------	--------	--	-------------------

5 cyl. 3.7L (E) FI	VO-108	VA-181		NS ⁴³⁷
--------------------	--------	--------	--	-------------------

Envoy

6 cyl. 4.2L (S) FI	VO-108	VA-161		NS ⁴³⁷
--------------------	--------	--------	--	-------------------

V8 5.3L (M) FI	VO-88	VA-161		NS ⁴³⁷
----------------	-------	--------	--	-------------------

Savana, Van

V6 4.3L (X) FI	VO-16	VA-169		NS ⁴³⁷
----------------	-------	--------	--	-------------------

V8 4.8L (V) FI	VO-88	VA-169		NS ⁴³⁷
----------------	-------	--------	--	-------------------

V8 5.3L (Z) (Flex Fuel)	VO-88	VA-169		NS ⁴³⁷
-------------------------	-------	--------	--	-------------------

V8 5.3L (T) FI	VO-88	VA-169		NS ⁴³⁷
----------------	-------	--------	--	-------------------

V8 6.0L (U) FI	VO-88	VA-169		NS ⁴³⁷
----------------	-------	--------	--	-------------------

V8 6.6L (2,6) Diesel Turbo	VO-75	VA-381		
----------------------------	-------	--------	--	--

Sierra Classic Pickup

V6 4.3L (X) FI	VO-16	VA-259		NS ⁴³⁷
----------------	-------	--------	--	-------------------

V8 4.8L (V) FI	VO-88	VA-259		NS ⁴³⁷
----------------	-------	--------	--	-------------------

V8 5.3L (Z) (Flex Fuel)	VO-88	VA-259		NS ⁴³⁷
-------------------------	-------	--------	--	-------------------

V8 5.3L (B,T) FI	VO-88	VA-259		NS ⁴³⁷
------------------	-------	--------	--	-------------------

V8 5.3L (T) FI (Hybrid)	VO-88	VA-259		NS ⁴³⁷
-------------------------	-------	--------	--	-------------------

V8 6.0L (N) FI	VO-88	VA-259		NS ⁴³⁷
----------------	-------	--------	--	-------------------

V8 6.0L (U) FI	VO-88	VA-259		NS ⁴³⁷
----------------	-------	--------	--	-------------------

Se reporter à table de matière pour les notes en bas de page en français. Utilize el contenido para ver notas a pie.

NS - Non-Serviceable / Non réparable / No reparable LF - Life-Time Filter / Filtro para toda la vida / Filtre à vie

⁴³⁷ Requires replacement of the complete fuel pump/fuel filter module.



GMC (cont'd)

2007

Sierra Classic Pickup

V8 6.6L (D) Diesel Turbo	VO-75	VA-218		
V8 8.1L (G) FI	VO-65	VA-259		NS ⁴³⁷

Sierra Pickup

V6 4.3L (X) FI	VO-16	VA-259		NS ⁴³⁷
V8 4.8L FI	VO-88	VA-259		NS ⁴³⁷
V8 5.3L FI	VO-88	VA-259		NS ⁴³⁷
V8 5.3L (T) FI (Hybrid)	VO-88	VA-259		NS ⁴³⁷
V8 6.0L FI	VO-88	VA-259		NS ⁴³⁷
V8 6.2L FI	VO-88	VA-259		NS ⁴³⁷
V8 6.6L Diesel Turbo	VO-75	VA-218		
V8 8.1L (G) FI	VO-65	VA-259		NS ⁴³⁷

Yukon, Yukon XL

V8 4.8L (C) FI	VO-88	VA-259		NS ⁴³⁷
V8 5.3L (3,0) FI (Flex Fuel)	VO-88	VA-259		NS ⁴³⁷
V8 5.3L (J) FI GAS	VO-88	VA-259		NS ⁴³⁷
V8 6.0L (K,Y) FI	VO-88	VA-259		NS ⁴³⁷
V8 6.2L (8) FI	VO-88	VA-259		NS ⁴³⁷

2006

Canyon

4 cyl. 2.8L (8) FI	VO-58	VA-181		NS ⁴³⁷
5 cyl. 3.5L (6) FI	VO-108	VA-181		NS ⁴³⁷

Envoy

6 cyl. 4.2L (S) FI	VO-108	VA-161		NS ⁴³⁷
V8 5.3L (M) FI	VO-58	VA-161		NS ⁴³⁷

Savana, Van

V6 4.3L (X) FI	VO-16	VA-169		NS ⁴³⁷
V8 4.8L (V) FI	VO-58	VA-169		NS ⁴³⁷
V8 5.3L (T) FI	VO-58	VA-169		NS ⁴³⁷
V8 6.0L (U) FI	VO-58	VA-169		NS ⁴³⁷
V8 6.6L (2) Diesel Turbo	VO-75	VA-381		

Sierra Pickup

V6 4.3L (X) FI	VO-16	VA-259		NS ⁴³⁷
V8 4.8L (V) FI	VO-58	VA-259		NS ⁴³⁷
V8 5.3L (B,T,Z) FI	VO-58	VA-259		NS ⁴³⁷
V8 5.3L (T) FI (Hybrid)	VO-58	VA-259		NS ⁴³⁷
V8 6.0L (N,U) FI	VO-58	VA-259		NS ⁴³⁷
V8 6.6L (2,D) Diesel Turbo	VO-75	VA-218		
V8 8.1L (G) FI	VO-65	VA-259		NS ⁴³⁷

Yukon, Yukon XL

V8 4.8L (V) FI	VO-58	VA-259		NS ⁴³⁷
V8 5.3L (Z) FI (Flex Fuel)	VO-58	VA-259		NS ⁴³⁷
V8 5.3L (T) FI GAS	VO-58	VA-259		NS ⁴³⁷
V8 6.0L (N,U) FI	VO-58	VA-259		NS ⁴³⁷
V8 8.1L (G) FI	VO-65	VA-259		NS ⁴³⁷

2005

Canyon

4 cyl. 2.8L (8) FI	VO-58	VA-181		VG-30
5 cyl. 3.5L (6) FI	VO-108	VA-181		VG-30

Envoy

6 cyl. 4.2L (S) FI	VO-108	VA-161		NS ⁴³⁷
V8 5.3L (M) FI	VO-58	VA-161		NS ⁴³⁷

Se reporter à table de matière pour les notes en bas de page en français. Utilize el contenido para ver notas a pie.

NS - Non-Serviceable / Non réparable / No repairable LF - Life-Time Filter / Filtro para toda la vida / Filtre à vie

⁴³⁷ Requires replacement of the complete fuel pump/fuel filter module.



GMC (cont'd)

2005

Jimmy (Canada)

V6 4.3L (X) FI	VO-55	VA-108		
----------------	-------	--------	--	--

Jimmy, Sonoma

V6 4.3L (W,X) FI	VO-55	VA-108		
------------------	-------	--------	--	--

Safari

V6 4.3L (X) FI	VO-16	VA-108		VG-14
----------------	-------	--------	--	-------

Savana, Van

V6 4.3L (X) FI	VO-16	VA-169		NS ⁴³⁷
V8 4.8L (V) FI	VO-58	VA-169		NS ⁴³⁷
V8 5.3L (T) FI	VO-58	VA-169		NS ⁴³⁷
V8 6.0L (U) FI	VO-58	VA-169		NS ⁴³⁷
V8 6.0L (U) FI CNG	VO-58	VA-169		

Sierra Pickup

V6 4.3L (X) FI	VO-16	VA-259		NS ⁴³⁷
V8 4.8L (V) FI	VO-58	VA-259		NS ⁴³⁷
V8 5.3L (B,T,Z) FI	VO-58	VA-259		NS ⁴³⁷
V8 5.3L (T) FI (Hybrid)	VO-58	VA-259		NS ⁴³⁷
V8 6.0L (N,U) FI	VO-58	VA-259		NS ⁴³⁷
V8 6.0L (U) FI CNG	VO-58	VA-259		NS ⁴³⁷
V8 6.6L (2) Diesel Turbo	VO-75	VA-271 ⁸⁹⁷		
V8 8.1L (G) FI	VO-65	VA-259		NS ⁴³⁷

Yukon, Yukon XL

V8 4.8L (V) FI	VO-58	VA-259		NS ⁴³⁷
V8 5.3L (Z) FI (Flex Fuel)	VO-58	VA-259		NS ⁴³⁷
V8 5.3L (T) FI GAS	VO-58	VA-259		NS ⁴³⁷
V8 6.0L (U) FI	VO-58	VA-259		NS ⁴³⁷
V8 8.1L (G) FI	VO-65	VA-259		NS ⁴³⁷

2004

Canyon

4 cyl. 2.8L (8) FI	VO-58	VA-181		VG-30
5 cyl. 3.5L (6) FI	VO-108	VA-181		VG-30

Envoy

6 cyl. 4.2L (S) FI	VO-108	VA-161		
V8 5.3L (P) FI	VO-58	VA-161		

Jimmy, Sonoma

V6 4.3L (W,X) FI	VO-55	VA-108		
------------------	-------	--------	--	--

Safari

V6 4.3L (X) FI	VO-16	VA-108		VG-14
----------------	-------	--------	--	-------

Savana, Van

V6 4.3L (X) FI	VO-16	VA-169		VG-14 ^{X574} VG-33 ^{Z574} NS ⁴³⁷
V8 4.8L (V) FI	VO-58	VA-169		NS ⁴³⁷
V8 5.3L (T) FI	VO-58	VA-169		NS ⁴³⁷
V8 6.0L (U) FI (CNG)	VO-58	VA-169		
V8 6.0L (U) FI (Gas)	VO-58	VA-169		NS ⁴³⁷

Sierra Pickup

V6 4.3L (X) FI	VO-16	VA-259	VCA-1074 ^{X111} VCA-1169 ^{Z111}	VG-14
V8 4.8L (V) FI	VO-58	VA-259	VCA-1074 ^{X111} VCA-1169 ^{Z111}	NS ⁴³⁷
V8 5.3L (Z) (Flex Fuel)	VO-58	VA-259	VCA-1074 ^{X111} VCA-1169 ^{Z111}	

Se reporter à table de matière pour les notes en bas de page en français. Utilize el contenido para ver notas a pie.

NS - Non-Serviceable / Non réparable / No reparable LF - Life-Time Filter / Filtro para toda la vida / Filtre à vie

⁴³⁷ Requires replacement of the complete fuel pump/fuel filter module. ⁸⁹⁷ Heavy Duty ^{X111}Optional Dust and odor filter. Used only if vehicle equipped with cabin air filter housing. ^{X574}Threaded both ends. ^{Z111}Dust filter. ^{Z574}Threaded one end.



GMC (cont'd)

2004

Sierra Pickup

V8 5.3L (T) FI	VO-58	VA-259	VCA-1074 ^{X111} VCA-1169 ^{Z111}	NS ⁴³⁷
V8 6.0L (U) FI (Gas)	VO-58	VA-259	VCA-1074 ^{X111} VCA-1169 ^{Z111}	NS ⁴³⁷
V8 6.0L (U) FI CNG	VO-58	VA-259	VCA-1074 ^{X111} VCA-1169 ^{Z111}	NS ⁴³⁷
V8 6.6L (1,2) Diesel Turbo	VO-75	VA-271 ⁸⁹⁷	VCA-1074 ^{X111} VCA-1169 ^{Z111}	
V8 8.1L (G) FI	VO-65	VA-259	VCA-1074 ^{X111} VCA-1169 ^{Z111}	NS ⁴³⁷

Yukon, Yukon XL

V8 4.8L (V) FI	VO-58	VA-259	VCA-1074 ^{X628} VCA-1169 ^{Z628}	NS ⁴³⁷
V8 5.3L (Z) FI (Flex Fuel)	VO-58	VA-259	VCA-1074 ^{X628} VCA-1169 ^{Z628}	
V8 5.3L (T) FI GAS	VO-58	VA-259	VCA-1074 ^{X628} VCA-1169 ^{Z628}	NS ⁴³⁷
V8 6.0L (U) FI	VO-58	VA-259	VCA-1074 ^{X628} VCA-1169 ^{Z628}	NS ⁴³⁷
V8 8.1L (G) FI	VO-65	VA-259	VCA-1074 ^{X628} VCA-1169 ^{Z628}	NS ⁴³⁷

2003

Envoy

6 cyl. 4.2L (S) FI	VO-108	VA-161		
V8 5.3L (P) FI	VO-58	VA-161		

Jimmy, Sonoma

4 cyl. 2.2L (H) FI	VO-16	VA-108		
V6 4.3L (W,X) FI	VO-16 ^{X161} VO-55 ^{Z161}	VA-108		

Safari

V6 4.3L (X) FI	VO-16	VA-108		VG-14
----------------	-------	--------	--	-------

Savana, Van

V6 4.3L (X) FI	VO-16	VA-169		VG-14 ^{X574} VG-33 ^{Z574}
V8 4.8L (V) FI	VO-58	VA-169		VG-14 ^{X574} VG-33 ^{Z574}
V8 5.3L (T) FI	VO-58	VA-169		VG-14 ^{X574} VG-33 ^{Z574}
V8 6.0L (U) FI (CNG)	VO-58	VA-169		NS ⁴³⁷
V8 6.0L (U) FI (Gas)	VO-58	VA-169		VG-14 ^{X574} VG-33 ^{Z574}

Sierra Pickup

V6 4.3L (X) FI	VO-16	VA-259	VCA-1074 ^{X111} VCA-1169 ^{Z111}	VG-14
V8 4.8L (V) FI	VO-58	VA-259	VCA-1074 ^{X111} VCA-1169 ^{Z111}	VG-14
V8 5.3L (Z) (Flex Fuel)	VO-58	VA-259	VCA-1074 ^{X111} VCA-1169 ^{Z111}	
V8 5.3L (T) FI	VO-58	VA-259	VCA-1074 ^{X111} VCA-1169 ^{Z111}	VG-14
V8 6.0L (U) FI (Gas)	VO-58	VA-259	VCA-1074 ^{X111} VCA-1169 ^{Z111}	VG-14

Se reporter à table de matière pour les notes en bas de page en français. Utilize el contenido para ver notas a pie.

NS - Non-Serviceable / Non réparable / No reparable LF - Life-Time Filter / Filtro para toda la vida / Filtre à vie

⁴³⁷ Requires replacement of the complete fuel pump/fuel filter module. ⁸⁹⁷ Heavy Duty ^{X111}Optional Dust and odor filter. Used only if vehicle equipped with cabin air filter housing. ^{X161}2WD ^{X574}Threaded both ends. ^{X628}Dust and odor. ^{Z111}Dust filter. ^{Z161}4WD ^{Z574}Threaded one end. ^{Z628}Dust filter.



GMC (cont'd)

2003

Sierra Pickup

V8 6.0L (U) FI CNG	VO-58	VA-259	VCA-1074 ^{X111} VCA-1169 ^{Z111}	NS ⁴³⁷
V8 6.6L (1) Diesel Turbo	VO-75	VA-271 ⁸⁹⁷	VCA-1074 ^{X111} VCA-1169 ^{Z111}	
V8 8.1L (G) FI	VO-65	VA-259	VCA-1074 ^{X111} VCA-1169 ^{Z111}	VG-14

Yukon, Yukon XL

V8 4.8L (V) FI	VO-58	VA-259	VCA-1074 ^{X628} VCA-1169 ^{Z628}	VG-14
V8 5.3L (Z) FI (Flex Fuel)	VO-58	VA-259	VCA-1074 ^{X628} VCA-1169 ^{Z628}	
V8 5.3L (T) FI GAS	VO-58	VA-259	VCA-1074 ^{X628} VCA-1169 ^{Z628}	VG-14
V8 6.0L (U) FI	VO-58	VA-259	VCA-1074 ^{X628} VCA-1169 ^{Z628}	VG-14
V8 8.1L (G) FI	VO-65	VA-259	VCA-1074 ^{X628} VCA-1169 ^{Z628}	VG-14

2002

C & K Series 3500 HD

V8 6.5L (F) Diesel Turbo	VO-56	VA-92		
V8 8.1L (G) FI	VO-65	VA-92		VG-14

Envoy

6 cyl. 4.2L (S) FI	VO-108	VA-161		
--------------------	--------	--------	--	--

Jimmy, Sonoma

4 cyl. 2.2L (5) FI (Alt. Fuel)	VO-16	VA-108		
V6 4.3L (W) FI	VO-16 ^{X161} VO-55 ^{Z161}	VA-108		

Safari

V6 4.3L (X) FI	VO-16	VA-108		VG-14
----------------	-------	--------	--	-------

Savana, Van

V6 4.3L (W) FI	VO-16	VA-169		VG-30
V8 5.0L (M) FI	VO-56	VA-169		VG-30
V8 5.7L (R) FI	VO-56	VA-169		VG-30
V8 6.5L (F) Diesel Turbo	VO-56	VFAP-917 ^{X385} VA-412 ^{Z385}		
V8 8.1L (G) FI	VO-65	VA-169		VG-30 ⁸⁴

Sierra Pickup

V6 4.3L (W,X) FI	VO-16	VA-259	VCA-1003	VG-14
V8 4.8L (V) FI	VO-108	VA-259	VCA-1003	VG-14
V8 5.3L (T) FI	VO-108	VA-259	VCA-1003	VG-14
V8 5.3L (Z) FI (Flex Fuel)	VO-108	VA-259	VCA-1003	
V8 6.0L (U) FI (Bi-Fuel)(CNG)	VO-108	VA-259	VCA-1074 ^{X111} VCA-1169 ^{Z111}	NS ⁴³⁷
V8 6.0L (U) FI (Gas)	VO-108	VA-259	VCA-1003	VG-14 ¹²⁸
V8 6.6L (1) Diesel Turbo	VO-75	VA-271 ⁸⁹⁷	VCA-1003	
V8 8.1L (G) FI	VO-65	VA-259	VCA-1003	VG-14

Yukon, Yukon XL

V8 4.8L (V) FI	VO-108	VA-259	VCA-1003	VG-14
V8 5.3L (Z) FI (Flex Fuel)	VO-108	VA-259	VCA-1003	
V8 5.3L (T) FI GAS	VO-108	VA-259	VCA-1003	VG-14
V8 6.0L (U) FI	VO-108	VA-259	VCA-1003	VG-14
V8 8.1L (G) FI	VO-65	VA-259	VCA-1003	VG-14

Se reporter à table de matière pour les notes en bas de page en français. Utilize el contenido para ver notas a pie.

NS - Non-Serviceable / Non réparable / No reparable LF - Life-Time Filter / Filtro para toda la vida / Filtre à vie

⁸⁴ In-line filter. ¹²⁸ Except CNG. ⁴³⁷ Requires replacement of the complete fuel pump/fuel filter module. ⁸⁹⁷ Heavy Duty ^{X111}Optional Dust and odor filter. Used only if vehicle equipped with cabin air filter housing. ^{X161}2WD ^{X385}Standard Duty service. ^{X628}Dust and odor. ^{Z111}Dust filter. ^{Z161}4WD

^{Z385}Heavy Duty service. ^{Z628}Dust filter.



GMC (cont'd)

	Oil	Air	Cabin*	Fuel
2001				
C & K Series 3500 HD				
V8 6.5L (F) Diesel Turbo	VO-56	VA-92		
V8 8.1L (G) FI	VO-65	VA-92		VG-14
Jimmy, Sonoma				
4 cyl. 2.2L (5) FI (Flex Fuel)	VO-16	VA-108		
V6 4.3L (W) FI	VO-16 ^{X161} VO-55 ^{Z161}	VA-108		
Safari				
V6 4.3L (W) FI	VO-16	VA-108		VG-14
Savana, Van				
V6 4.3L (W) FI	VO-16	VA-169		VG-30
V8 5.0L (M) FI	VO-56	VA-169		VG-30
V8 5.7L (R) FI	VO-56	VA-169		VG-30
V8 5.7L (R) FI (Bi-Fuel)	VO-56	VA-169		VG-30 ⁸⁴
V8 6.5L (F) Diesel Turbo	VO-56	VFAP-917 ^{X385} VA-412 ^{Z385}		
V8 8.1L (G) FI	VO-65	VA-169		VG-30 ⁸⁴
Sierra Pickup				
V6 4.3L (W) FI	VO-16	VA-259	VCA-1003	VG-14
V8 4.8L (V) FI	VO-108	VA-259	VCA-1003	VG-14
V8 5.3L (T) FI	VO-108	VA-259	VCA-1003	VG-14
V8 6.0L (U) FI	VO-108	VA-259	VCA-1003	VG-14
V8 6.6L (1) Diesel Turbo	VO-75	VA-271 ⁸⁹⁷	VCA-1003	
V8 8.1L (G) FI	VO-65	VA-259	VCA-1003	VG-14
Yukon, Yukon XL				
V8 4.8L (V) FI	VO-108	VA-259	VCA-1003	VG-14
V8 5.3L (T) FI	VO-108	VA-259	VCA-1003	VG-14
V8 6.0L (U) FI	VO-108	VA-259	VCA-1003	VG-14
V8 8.1L (G) FI	VO-65	VA-259	VCA-1003	VG-14
2000				
C & K Series Pickup				
V8 5.7L (R) FI (2WD)	VO-56	VA-92		VG-14
V8 5.7L (R) FI (4WD)	VO-55	VA-92		VG-14
V8 6.5L (F) Diesel Turbo	VO-56	VA-92		
V8 7.4L (J) FI (2WD)	VO-56 ^{X410} VO-65 ^{Z410}			
V8 7.4L (J) FI (4WD)	VO-65	VA-92		VG-14
V8 7.4L (J) FI (4WD)	VO-65	VA-92		VG-14
Jimmy, Sonoma				
4 cyl. 2.2L (4) FI	VO-16	VA-108		
4 cyl. 2.2L (5) FI Flex Fuel	VO-16	VA-108		
V6 4.3L (W) FI	VO-16 ^{X161} VO-55 ^{Z161}	VA-108		
Safari				
V6 4.3L (W) FI	VO-16	VA-108		VG-14
Savana, Van				
V6 4.3L (W) FI	VO-16	VFAP-917		VG-30
V8 5.0L (M) FI	VO-56	VFAP-917		VG-30
V8 5.7L (R) FI	VO-56	VFAP-917		VG-30
V8 6.5L (F) Diesel Turbo	VO-56	VFAP-917 ^{X385} VA-412 ^{Z385}		
V8 7.4L (J) FI	VO-56 ^{X410} VO-65 ^{Z410}	VFAP-917		VG-30 ⁸⁴

Se reporter à table de matière pour les notes en bas de page en français. Utilize el contenido para ver notas a pie.

NS - Non-Serviceable / Non réparable / No reparable LF - Life-Time Filter / Filtro para toda la vida / Filtre à vie

⁸⁴ In-line filter. ⁸⁹⁷ Heavy Duty ^{X161}2WD ^{X385}Standard Duty service. ^{X410}Long filter. ^{Z161}4WD ^{Z385}Heavy Duty service. ^{Z410}Short filter.



GMC (cont'd)

2000

Sierra Pickup

V6 4.3L (W) FI	VO-16	VA-259	VCA-1003	VG-14
V8 4.8L (V) FI	VO-108	VA-259	VCA-1003	VG-14
V8 5.3L (T) FI	VO-108	VA-259	VCA-1003	VG-14
V8 6.0L (U) FI	VO-108	VA-259	VCA-1003	VG-14

Yukon, Yukon XL

V8 4.8L (V) FI	VO-108	VA-259	VCA-1003	VG-14
V8 5.3L (T) FI	VO-108	VA-259	VCA-1003	VG-14
V8 5.7L (R) FI	VO-55	VA-92		VG-14
V8 6.0L (U) FI	VO-108	VA-259	VCA-1003	VG-14

1999

C & K Series Pickup

V8 5.0L (M) FI (2WD)	VO-56	VA-92		VG-14
V8 5.0L (M) FI (4WD)	VO-55	VA-92		VG-14
V8 5.7L (R) FI (2WD)	VO-56	VA-92		VG-14
V8 5.7L (R) FI (4WD)	VO-55	VA-92		VG-14
V8 6.5L (F,S) Diesel Turbo	VO-56	VA-92		
V8 7.4L (J) FI	VO-56 ^{X410} VO-65 ^{Z410}	VA-92		VG-14

Jimmy, Sonoma

4 cyl. 2.2L (4) FI	VO-16	VA-108		
V6 4.3L (W,X) FI	VO-55	VA-108		

Safari

V6 4.3L (W) FI	VO-55	VA-108		VG-14
----------------	-------	--------	--	-------

Savana, Van

V6 4.3L (W) FI	VO-55	VFAP-917		VG-30
V8 5.0L (M) FI	VO-56	VFAP-917		VG-30
V8 5.7L (R) FI	VO-56	VFAP-917		VG-30
V8 6.5L (F) Diesel Turbo	VO-56	VFAP-917 ^{X385} VA-412 ^{Z385}		
V8 7.4L (J) FI	VO-65	VFAP-917		VG-30 ⁸⁴

Sierra Pickup

V6 4.3L (W) FI	VO-55	VA-259	VCA-1003	VG-14
V8 4.8L (V) FI	VO-108	VA-259	VCA-1003	VG-14
V8 5.3L (T) FI	VO-108	VA-259	VCA-1003	VG-14
V8 6.0L (U) FI	VO-108	VA-259	VCA-1003	VG-14

Van P Series

V6 4.3L (W) FI	VO-16	VA-412		VG-14
V8 5.7L (R) FI	VO-55	VA-412		VG-14
V8 6.5L (F) Diesel Turbo	VO-56	VA-412		
V8 6.5L (Y) FI Diesel	VO-56			
V8 7.4L (B) FI	VO-56	VA-320		VG-14
V8 7.4L (J) FI	VO-65	VA-412		VG-14

Yukon, Yukon XL

V8 5.7L (R) FI (4WD)	VO-55	VA-92		VG-14
V8 5.7L (R) FI (RWD)	VO-56	VA-92		VG-14
V8 6.5L (F) Diesel Turbo	VO-56	VA-92		
V8 7.4L (J) FI (2WD)	VO-56	VA-92		VG-14
V8 7.4L (J) FI (4WD)	VO-65	VA-92		VG-14

1998

C & K Series Pickup, Suburban, Yukon

V6 4.3L (W) FI	VO-55	VA-92		VG-14
V8 5.0L (M) FI (2WD)	VO-56	VA-92		VG-14

Se reporter à table de matière pour les notes en bas de page en français. Utilize el contenido para ver notas a pie.

NS - Non-Serviceable / Non réparable / No repairable LF - Life-Time Filter / Filtro para toda la vida / Filtre à vie

⁸⁴ In-line filter. ^{X385} Standard Duty service. ^{X410} Long filter. ^{Z385} Heavy Duty service. ^{Z410} Short filter.



GMC (cont'd)

1998

C & K Series Pickup, Suburban, Yukon

V8 5.0L (M) FI (4WD)	VO-55	VA-92		VG-14
V8 5.7L (R) FI (2WD)	VO-56	VA-92		VG-14
V8 5.7L (R) FI (4WD)	VO-55	VA-92		VG-14
V8 6.5L Diesel Turbo	VO-56	VA-92		VG-14
V8 7.4L (J) FI	VO-56	VA-92		VG-14

Jimmy, Sonoma

4 cyl. 2.2L (4) FI	VO-16	VA-108		
V6 4.3L (W,X) FI	VO-55	VA-108		

Safari

V6 4.3L (W) FI	VO-55	VA-108		VG-14
----------------	-------	--------	--	-------

Savana, Van

V6 4.3L (W) FI	VO-55	VFAP-917		VG-30
V8 5.0L (M) FI	VO-56	VFAP-917		VG-30
V8 5.7L (R) FI	VO-56	VFAP-917		VG-30
V8 6.5L (F) Diesel Turbo	VO-56	VFAP-917 ^{X385} VA-412 ^{Z385}		VG-30 ⁸⁴
V8 7.4L (J) FI	VO-56	VFAP-917		VG-30 ⁸⁴

Van P Series

V6 4.3L (W) FI	VO-55	VA-412		VG-14
V8 5.7L (R) FI	VO-55	VA-412		VG-14
V8 6.5L (F) Diesel Turbo	VO-56	VA-412		
V8 6.5L (Y) FI Diesel	VO-56			
V8 7.4L (B) FI	VO-56	VA-320		VG-14
V8 7.4L (J) FI	VO-56	VA-412		VG-14

1997

C & K Series Pickup, Suburban, Yukon

V6 4.3L (W) FI	VO-55	VA-92		VG-14
V8 5.0L (M) FI (2WD)	VO-56	VA-92		VG-14
V8 5.0L (M) FI (4WD)	VO-55	VA-92		VG-14
V8 5.7L (R) FI (2WD)	VO-56	VA-92		VG-14
V8 5.7L (R) FI (4WD)	VO-55	VA-92		VG-14
V8 6.5L Diesel Turbo	VO-56	VA-92		VG-14
V8 7.4L (J) FI	VO-56	VA-92		VG-14

Jimmy, Sonoma

4 cyl. 2.2L (4) FI	VO-16	VA-108		
V6 4.3L (W,X) FI	VO-55	VA-108		

Safari

V6 4.3L (W) FI	VO-55	VA-108		VG-14
----------------	-------	--------	--	-------

Savana, Van

V6 4.3L (W) FI	VO-55	VFAP-917		VG-30
V8 5.0L (M) FI	VO-56	VFAP-917		VG-30
V8 5.7L (R) FI	VO-56	VFAP-917		VG-30
V8 6.5L (F) Diesel Turbo	VO-56	VFAP-917 ^{X385} VA-412 ^{Z385}		VG-30 ⁸⁴
V8 7.4L (J) FI	VO-56	VFAP-917		VG-30 ⁸⁴

Van P Series

V6 4.3L (W) FI	VO-55	VA-412		VG-14
V8 5.7L (R) FI	VO-55	VA-412		VG-14
V8 6.5L (F) Diesel Turbo	VO-56	VA-412		
V8 6.5L (Y) FI Diesel	VO-56			
V8 7.4L (J) FI	VO-56	VA-412		VG-14
V8 7.4L (N) FI	VO-56	VA-2		VG-14

Se reporter à table de matière pour les notes en bas de page en français. Utilize el contenido para ver notas a pie.

NS - Non-Serviceable / Non réparable / No reparable LF - Life-Time Filter / Filtro para toda la vida / Filtre à vie

⁸⁴ In-line filter. ^{X385} Standard Duty service. ^{Z385} Heavy Duty service.



GMC (cont'd)

1996

C & K Series Pickup, Suburban, Yukon

V6 4.3L (W) FI	VO-55	VA-92		VG-14
V8 5.0L (M) FI (2WD)	VO-56	VA-92		VG-14
V8 5.0L (M) FI (4WD)	VO-55	VA-92		VG-14
V8 5.7L (R) FI (2WD)	VO-56	VA-92		VG-14
V8 5.7L (R) FI (4WD)	VO-55	VA-92		VG-14
V8 6.5L (F) Diesel Turbo	VO-56	VFAP-917 ^{X385} VA-412 ^{Z385}		
V8 6.5L (S) Diesel Turbo	VO-56	VFAP-917 ^{X385} VA-412 ^{Z385}		
V8 7.4L (J) FI	VO-56	VA-92		VG-14

Jimmy, Sonoma

4 cyl. 2.2L (4) FI	VO-16	VA-108		VG-14
V6 4.3L (W,X) FI	VO-55	VA-108		VG-14

Safari

V6 4.3L (W) FI	VO-55	VA-108		VG-14
----------------	-------	--------	--	-------

Savana, Van

V6 4.3L (W) FI	VO-55	VFAP-917		VG-30
V8 5.0L (M) FI	VO-56	VFAP-917		VG-30
V8 5.7L (K) FI	VO-56	VA-402		VG-14
V8 5.7L (R) FI	VO-56	VFAP-917		VG-30 ⁸⁴
V8 6.5L (F) Diesel Turbo	VO-56	VFAP-917 ^{X385} VA-412 ^{Z385}		
V8 7.4L (N) FI	VO-56	VA-2		VG-14 ⁸⁴
V8 7.4L (J) FI	VO-56	VFAP-917		VG-30 ⁸⁴

Van G Series

V8 5.7L (K) FI	VO-56	VA-402		VG-14
V8 6.5L (Y) FI Diesel	VO-56			
V8 7.4L (N) FI	VO-56	VA-2		VG-14 ⁸⁴

Van P Series

V6 4.3L (W) FI	VO-55	VFAP-917		VG-14
V8 5.7L (R) FI	VO-55	VFAP-917		VG-14
V8 5.7L (K) FI	VO-56	VA-2 ^{X367} VA-402 ^{Z367}		VG-14
V8 6.5L (Y) FI Diesel	VO-56			
V8 7.4L (J) FI	VO-56	VFAP-917		VG-14
V8 7.4L (N) FI	VO-56	VA-2		VG-14

1995

C & K Series Pickup, Suburban, Yukon

V6 4.3L (Z) FI	VO-55	VA-402		VG-14
V8 5.0L (H) FI (2WD)	VO-56	VA-2		VG-14
V8 5.0L (H) FI (4WD)	VO-55	VA-2		VG-14
V8 5.7L (K) FI (2WD)	VO-56	VA-2		VG-14
V8 5.7L (K) FI (4WD)	VO-55	VA-2		VG-14
V8 6.5L Diesel Turbo	VO-56	VFAP-917 ^{X385} VA-412 ^{Z385}		
V8 6.5L (P) FI Diesel	VO-56	VA-45		
V8 7.4L (N) FI	VO-56	VA-2		VG-14

Jimmy, Sonoma

4 cyl. 2.2L (4) FI	VO-16	VA-108		VG-14
V6 4.3L (Z) FI	VO-55	VA-38		VG-14
V6 4.3L (W) FI	VO-55	VA-108		VG-14

Se reporter à table de matière pour les notes en bas de page en français. Utilize el contenido para ver notas a pie.

NS - Non-Serviceable / Non réparable / No reparable LF - Life-Time Filter / Filtro para toda la vida / Filtre à vie

⁸⁴ In-line filter. ^{X367}12 inch O.D. ^{X385}Standard Duty service. ^{Z367}9.75 inch O.D. ^{Z385}Heavy Duty service.



GMC (cont'd)

1995

Safari				
V6 4.3L (W) FI	VO-55	VA-108		VG-14
Van G Series				
V6 4.3L (Z) FI	VO-55	VA-402		VG-14
V8 5.0L (H) FI	VO-56	VA-402		VG-14
V8 5.7L (K) FI	VO-56	VA-402		VG-14
V8 6.5L (P) FI Diesel	VO-56	VA-45		
V8 6.5L (Y) FI Diesel	VO-56	VA-45		
V8 7.4L (N) FI	VO-56	VA-2		VG-14 ⁸⁴
Van P Series				
V6 4.3L (Z) FI	VO-55	VA-402		VG-14
V8 5.7L (K) FI	VO-56	VA-2 ^{X367}		VG-14
		VA-402 ^{Z367}		
V8 6.5L (Y) FI Diesel	VO-56	VA-45		
V8 7.4L (N) FI	VO-56	VA-2		VG-14

HONDA

2019

Accord				
4 cyl. 1.5L Turbo	VO-106	VA-497	VCA-1063	NS ⁴³⁷
4 cyl. 2.0L Hybrid	VO-106		VCA-1063	NS ⁴³⁷
4 cyl. 2.0L Turbo	VO-106		VCA-1063	NS ⁴³⁷
Civic				
4 cyl. 1.5L Turbo	VO-106	VA-464	VCA-1061	NS ⁴³⁷
4 cyl. 2.0L Non turbo	VO-106	VA-454	VCA-1061	NS ⁴³⁷
4 cyl. 2.0L Turbo	VO-106		VCA-1061	NS ⁴³⁷
Clarity				
4 cyl. 1.5L	VO-106			NS ⁴³⁷
CR-V				
4 cyl. 1.5L Turbo	VO-106	VA-464	VCA-1061	NS ⁴³⁷
4 cyl. 2.4L	VO-106		VCA-1061	NS ⁴³⁷
FIT				
4 cyl. 1.5L	VO-106	VA-432	VCA-1061	NS ⁴³⁷
HR-V				
4 cyl. 1.8L	VO-106	VA-466	VCA-1061	NS ⁴³⁷
Insight				
4 cyl 1.5L Hybrid	VO-106		VCA-1061	NS ⁴³⁷
Odyssey				
V6 3.5L	VO-106	VA-456	VCA-1061	NS ⁴³⁷
Pilot				
V6 3.5L	VO-106	VA-456	VCA-1063	NS ⁴³⁷
Ridgeline				
V6 3.5L	VO-106	VA-456	VCA-1063	NS ⁴³⁷

2018

Accord				
4 cyl. 1.5L Turbo	VO-106	VA-497	VCA-1063	NS ⁴³⁷
4 cyl. 2.0L Hybrid	VO-106		VCA-1063	NS ⁴³⁷
4 cyl. 2.0L Turbo	VO-106		VCA-1063	NS ⁴³⁷
Civic				
4 cyl. 1.5L Turbo	VO-106	VA-464	VCA-1061	NS ⁴³⁷
4 cyl. 2.0L Non turbo	VO-106	VA-454	VCA-1061	NS ⁴³⁷
4 cyl. 2.0L Turbo	VO-106		VCA-1061	NS ⁴³⁷

Se reporter à table de matière pour les notes en bas de page en français. Utilize el contenido para ver notas a pie.

NS - Non-Serviceable / Non réparable / No reparable LF - Life-Time Filter / Filtro para toda la vida / Filtre à vie

⁸⁴ In-line filter. ⁴³⁷ Requires replacement of the complete fuel pump/fuel filter module. ^{X367}12 inch O.D. ^{Z367}9.75 inch O.D.



HONDA (cont'd)

2018

Clarity

4 cyl. 1.5L	VO-106			NS ⁴³⁷
-------------	--------	--	--	-------------------

CR-V

4 cyl. 1.5L Turbo	VO-106	VA-464	VCA-1061	NS ⁴³⁷
-------------------	--------	--------	----------	-------------------

4 cyl. 2.4L	VO-106		VCA-1061	NS ⁴³⁷
-------------	--------	--	----------	-------------------

FIT

4 cyl. 1.5L	VO-106	VA-432	VCA-1061	NS ⁴³⁷
-------------	--------	--------	----------	-------------------

HR-V

4 cyl. 1.8L	VO-106	VA-466	VCA-1061	NS ⁴³⁷
-------------	--------	--------	----------	-------------------

Odyssey

V6 3.5L	VO-106	VA-456	VCA-1061	NS ⁴³⁷
---------	--------	--------	----------	-------------------

Pilot

V6 3.5L	VO-106	VA-456	VCA-1063	NS ⁴³⁷
---------	--------	--------	----------	-------------------

Ridgeline

V6 3.5L	VO-106	VA-456	VCA-1063	NS ⁴³⁷
---------	--------	--------	----------	-------------------

2017

Accord

4 cyl. 2.0L Hybrid	VO-106		VCA-1063	NS ⁴³⁷
--------------------	--------	--	----------	-------------------

4 cyl. 2.4L	VO-106	VA-304	VCA-1063	NS ⁴³⁷
-------------	--------	--------	----------	-------------------

V6 3.5L	VO-106	VA-305	VCA-1063	NS ⁴³⁷
---------	--------	--------	----------	-------------------

Civic

4 cyl. 1.5L Turbo	VO-106	VA-464	VCA-1061	NS ⁴³⁷
-------------------	--------	--------	----------	-------------------

4 cyl. 2.0L	VO-106	VA-454	VCA-1061	NS ⁴³⁷
-------------	--------	--------	----------	-------------------

CR-V

4 cyl. 1.5L Turbo	VO-106	VA-464	VCA-1061	NS ⁴³⁷
-------------------	--------	--------	----------	-------------------

4 cyl. 2.4L	VO-106		VCA-1061	NS ⁴³⁷
-------------	--------	--	----------	-------------------

FIT

4 cyl. 1.5L	VO-106	VA-432	VCA-1061	NS ⁴³⁷
-------------	--------	--------	----------	-------------------

HR-V

4 cyl. 1.8L	VO-106	VA-466	VCA-1061	NS ⁴³⁷
-------------	--------	--------	----------	-------------------

Odyssey

V6 3.5L	VO-106	VA-291	VCA-1063	NS ⁴³⁷
---------	--------	--------	----------	-------------------

Pilot

V6 3.5L	VO-106	VA-456	VCA-1063	NS ⁴³⁷
---------	--------	--------	----------	-------------------

Ridgeline

V6 3.5L	VO-106	VA-456	VCA-1063	NS ⁴³⁷
---------	--------	--------	----------	-------------------

2016

Accord

4 cyl. 2.4L	VO-106	VA-304	VCA-1063	NS
-------------	--------	--------	----------	----

V6 3.5L	VO-106	VA-305	VCA-1063	NS ⁴³⁷
---------	--------	--------	----------	-------------------

Civic

4 cyl. 1.5L Turbo	VO-106	VA-464	VCA-1061	NS ⁴³⁷
-------------------	--------	--------	----------	-------------------

4 cyl. 2.0L	VO-106	VA-454	VCA-1061	NS ⁴³⁷
-------------	--------	--------	----------	-------------------

CR-V

4 cyl. 2.4L	VO-106	VA-431	VCA-1063	NS ⁴³⁷
-------------	--------	--------	----------	-------------------

CR-Z

4 cyl. 1.5L Hybrid	VO-106		VCA-1061	NS ⁴³⁷
--------------------	--------	--	----------	-------------------

FIT

4 cyl. 1.5L	VO-106	VA-432	VCA-1061	NS ⁴³⁷
-------------	--------	--------	----------	-------------------

HR-V

4 cyl. 1.8L	VO-106	VA-466	VCA-1061	NS ⁴³⁷
-------------	--------	--------	----------	-------------------

Se reporter à table de matière pour les notes en bas de page en français. Utilize el contenido para ver notas a pie.

NS - Non-Serviceable / Non réparable / No reparable LF - Life-Time Filter / Filtro para toda la vida / Filtre à vie

⁴³⁷ Requires replacement of the complete fuel pump/fuel filter module.



HONDA (cont'd)

	Oil	Air	Cabin*	Fuel
2016				
Odyssey				
V6 3.5L	VO-106	VA-291	VCA-1063	NS ⁴³⁷
Pilot				
V6 3.5L	VO-106	VA-456	VCA-1063	NS ⁴³⁷
2015				
Accord				
4 cyl. 2.0L Hybrid	VO-106		VCA-1063	NS ⁴³⁷
4 cyl. 2.4L	VO-106	VA-304	VCA-1063	NS
V6 3.5L	VO-106	VA-305	VCA-1063	NS ⁴³⁷
Civic				
4 cyl. 1.8L	VO-106	VA-292	VCA-1063	NS ⁴³⁷
Civic Hybrid				
4 cyl. 1.5L Hybrid	VO-106		VCA-1063	NS ⁴³⁷
Civic Si				
4 cyl. 2.4L	VO-106	VA-297	VCA-1063	NS ⁴³⁷
Crosstour				
4 cyl. 2.4L	VO-106	VA-221	VCA-1063	NS ⁴³⁷
V6 3.5L	VO-106	VA-220	VCA-1063	NS ⁴³⁷
CR-V				
4 cyl. 2.4L	VO-106	VA-431	VCA-1063	NS ⁴³⁷
CR-Z				
4 cyl. 1.5L Hybrid	VO-106		VCA-1061	NS ⁴³⁷
FIT				
4 cyl. 1.5L	VO-106	VA-432	VCA-1061	NS ⁴³⁷
Odyssey				
V6 3.5L	VO-106	VA-291	VCA-1063	NS ⁴³⁷
Pilot				
V6 3.5L	VO-106	VA-202	VCA-1063	NS ⁴³⁷
2014				
Accord				
4 cyl. 2.0L Hybrid	VO-106		VCA-1063	NS ⁴³⁷
4 cyl. 2.4L	VO-106	VA-304	VCA-1063	NS
V6 3.5L	VO-106	VA-305	VCA-1063	NS ⁴³⁷
Civic				
4 cyl. 1.8L FI CNG	VO-106	VA-212	VCA-1063	NS ⁴³⁷
4 cyl. 1.8L FI GAS	VO-106	VA-292	VCA-1063	NS ⁴³⁷
Civic Hybrid				
4 cyl. 1.5L Hybrid	VO-106		VCA-1063	NS ⁴³⁷
Civic Si				
4 cyl. 2.4L	VO-106	VA-297	VCA-1063	NS ⁴³⁷
Crosstour				
4 cyl. 2.4L	VO-106	VA-221	VCA-1063	NS ⁴³⁷
V6 3.5L	VO-106	VA-220	VCA-1063	NS ⁴³⁷
CR-V				
4 cyl. 2.4L	VO-106	VA-307	VCA-1063	NS ⁴³⁷
CR-Z				
4 cyl. 1.5L Hybrid	VO-106		VCA-1061	NS ⁴³⁷
FIT				
Electric			VCA-1061	
4 cyl. 1.5L	VO-106	VA-250	VCA-1061	NS ⁴³⁷
Insight				
4 cyl. 1.3L (Hybrid)	VO-106	VA-366	VCA-1061	NS ⁴³⁷

Se reporter à table de matière pour les notes en bas de page en français. Utilize el contenido para ver notas a pie.

NS - Non-Serviceable / Non réparable / No reparable LF - Life-Time Filter / Filtro para toda la vida / Filtre à vie

⁴³⁷ Requires replacement of the complete fuel pump/fuel filter module.



HONDA (cont'd)

2014

Odyssey

V6 3.5L	VO-106	VA-291	VCA-1063	NS ⁴³⁷
---------	--------	--------	----------	-------------------

Pilot

V6 3.5L	VO-106	VA-202	VCA-1063	NS ⁴³⁷
---------	--------	--------	----------	-------------------

Ridgeline

V6 3.5L	VO-106	VA-210	VCA-1063	NS ⁴³⁷
---------	--------	--------	----------	-------------------

2013

Accord

4 cyl. 2.4L	VO-106	VA-304	VCA-1063	NS ⁴³⁷
-------------	--------	--------	----------	-------------------

V6 3.5L	VO-106	VA-305	VCA-1063	NS ⁴³⁷
---------	--------	--------	----------	-------------------

Civic

4 cyl. 1.8L FI CNG	VO-106	VA-212	VCA-1063	NS ⁴³⁷
--------------------	--------	--------	----------	-------------------

4 cyl. 1.8L FI GAS	VO-106	VA-292	VCA-1063	NS ⁴³⁷
--------------------	--------	--------	----------	-------------------

Civic Hybrid

4 cyl. 1.5L Hybrid	VO-106		VCA-1063	NS ⁴³⁷
--------------------	--------	--	----------	-------------------

Civic Si

4 cyl. 2.4L	VO-106	VA-297	VCA-1063	NS ⁴³⁷
-------------	--------	--------	----------	-------------------

Crosstour

4 cyl. 2.4L	VO-106	VA-221	VCA-1063	NS ⁴³⁷
-------------	--------	--------	----------	-------------------

V6 3.5L	VO-106	VA-220	VCA-1063	NS ⁴³⁷
---------	--------	--------	----------	-------------------

CR-V

4 cyl. 2.4L	VO-106	VA-307	VCA-1063	NS ⁴³⁷
-------------	--------	--------	----------	-------------------

CR-Z

4 cyl. 1.5L Hybrid	VO-106		VCA-1061	NS ⁴³⁷
--------------------	--------	--	----------	-------------------

FIT

4 cyl. 1.5L	VO-106	VA-250	VCA-1061	NS ⁴³⁷
-------------	--------	--------	----------	-------------------

Insight

4 cyl 1.3L (Hybrid)	VO-106	VA-366	VCA-1061	NS ⁴³⁷
---------------------	--------	--------	----------	-------------------

Odyssey

V6 3.5L	VO-106	VA-291	VCA-1063	NS ⁴³⁷
---------	--------	--------	----------	-------------------

Pilot

V6 3.5L	VO-106	VA-202	VCA-1063	NS ⁴³⁷
---------	--------	--------	----------	-------------------

Ridgeline

V6 3.5L	VO-106	VA-210	VCA-1063	NS ⁴³⁷
---------	--------	--------	----------	-------------------

2012

Accord

4 cyl. 2.4L	VO-106	VA-221	VCA-1063	NS ⁴³⁷
-------------	--------	--------	----------	-------------------

V6 3.5L	VO-106	VA-220	VCA-1063	NS ⁴³⁷
---------	--------	--------	----------	-------------------

Civic

4 cyl. 1.8L FI CNG	VO-106	VA-212	VCA-1063	NS ⁴³⁷
--------------------	--------	--------	----------	-------------------

4 cyl. 1.8L FI GAS	VO-106	VA-292	VCA-1063	NS ⁴³⁷
--------------------	--------	--------	----------	-------------------

Civic Hybrid

4 cyl. 1.5L Hybrid	VO-106		VCA-1063	NS ⁴³⁷
--------------------	--------	--	----------	-------------------

Civic Si

4 cyl. 2.4L	VO-106	VA-297	VCA-1063	NS ⁴³⁷
-------------	--------	--------	----------	-------------------

Crosstour

4 cyl. 2.4L	VO-106	VA-221	VCA-1063	NS ⁴³⁷
-------------	--------	--------	----------	-------------------

V6 3.5L	VO-106	VA-220	VCA-1063	NS ⁴³⁷
---------	--------	--------	----------	-------------------

CR-V

4 cyl. 2.4L	VO-106	VA-307	VCA-1063	NS ⁴³⁷
-------------	--------	--------	----------	-------------------

CR-Z

4 cyl. 1.5L Hybrid	VO-106		VCA-1061	NS ⁴³⁷
--------------------	--------	--	----------	-------------------

Se reporter à table de matière pour les notes en bas de page en français. Utilize el contenido para ver notas a pie.

NS - Non-Serviceable / Non réparable / No reparable LF - Life-Time Filter / Filtro para toda la vida / Filtre à vie

⁴³⁷ Requires replacement of the complete fuel pump/fuel filter module.



HONDA (cont'd)

	Oil	Air	Cabin*	Fuel
2012				
FIT				
4 cyl. 1.5L	VO-106	VA-250	VCA-1061	NS ⁴³⁷
Insight				
4 cyl 1.3L (Hybrid)	VO-106	VA-366	VCA-1061	NS ⁴³⁷
Odyssey				
V6 3.5L	VO-106	VA-291	VCA-1063	NS ⁴³⁷
Pilot				
V6 3.5L	VO-106	VA-202	VCA-1063	NS ⁴³⁷
Ridgeline				
V6 3.5L	VO-106	VA-210	VCA-1063	NS ⁴³⁷
2011				
Accord				
4 cyl. 2.4L	VO-106	VA-221	VCA-1063	NS ⁴³⁷
V6 3.5L	VO-106	VA-220	VCA-1063	NS ⁴³⁷
Accord Crosstour				
V6 3.5L	VO-106	VA-220	VCA-1063	NS ⁴³⁷
Civic				
4 cyl. 1.8L FI CNG	VO-106	VA-212	VCA-1063	NS ⁴³⁷
4 cyl. 1.8L FI GAS	VO-106	VA-212	VCA-1063	NS ⁴³⁷
Civic Hybrid				
4 cyl. 1.3L Hybrid	VO-106	VA-343	VCA-1063	NS ⁴³⁷
Civic Si				
4 cyl. 2.0L	VO-106	VA-237	VCA-1063	NS ⁴³⁷
CR-V				
4 cyl. 2.4L	VO-106	VA-275	VCA-1063	NS ⁴³⁷
CR-Z				
4 cyl. 1.5L Hybrid	VO-106		VCA-1061	NS ⁴³⁷
Element				
4 cyl. 2.4L	VO-106	VA-237	VCA-1012	NS ⁴³⁷
FIT				
4 cyl. 1.5L	VO-106	VA-250	VCA-1061	NS ⁴³⁷
Insight				
4 cyl 1.3L (Hybrid)	VO-106	VA-366	VCA-1061	NS ⁴³⁷
Odyssey				
V6 3.5L	VO-106	VA-291	VCA-1063	NS ⁴³⁷
Pilot				
V6 3.5L	VO-106	VA-202	VCA-1063	NS ⁴³⁷
Ridgeline				
V6 3.5L	VO-106	VA-210	VCA-1063	NS ⁴³⁷
2010				
Accord				
4 cyl. 2.4L	VO-106	VA-221	VCA-1063	NS ⁴³⁷
V6 3.5L	VO-106	VA-220	VCA-1063	NS ⁴³⁷
Accord Crosstour				
V6 3.5L	VO-106	VA-220	VCA-1063	NS ⁴³⁷
Civic				
4 cyl. 1.8L FI (CNG)	VO-106	VA-212	VCA-1063	NS ⁴³⁷
4 cyl. 1.8L FI GAS	VO-106	VA-212	VCA-1063	NS ⁴³⁷
Civic Hybrid				
4 cyl. 1.3L Hybrid	VO-106	VA-343	VCA-1063	NS ⁴³⁷
Civic Si				
4 cyl. 2.0L	VO-106	VA-237	VCA-1063	NS ⁴³⁷

Se reporter à table de matière pour les notes en bas de page en français. Utilize el contenido para ver notas a pie.

NS - Non-Serviceable / Non réparable / No reparable LF - Life-Time Filter / Filtro para toda la vida / Filtre à vie

⁴³⁷ Requires replacement of the complete fuel pump/fuel filter module.



HONDA (cont'd)

2010

CR-V

4 cyl. 2.4L	VO-106	VA-275	VCA-1063	NS ⁴³⁷
-------------	--------	--------	----------	-------------------

Element

4 cyl. 2.4L	VO-106	VA-237	VCA-1012	NS ⁴³⁷
-------------	--------	--------	----------	-------------------

FIT

4 cyl. 1.5L	VO-106	VA-250	VCA-1061	NS ⁴³⁷
-------------	--------	--------	----------	-------------------

Insight

4 cyl 1.3L (Hybrid)	VO-106	VA-366	VCA-1061	NS ⁴³⁷
---------------------	--------	--------	----------	-------------------

Odyssey

V6 3.5L	VO-106	VA-202	VCA-1063	NS ⁴³⁷
---------	--------	--------	----------	-------------------

Pilot

V6 3.5L	VO-106	VA-202	VCA-1063	NS ⁴³⁷
---------	--------	--------	----------	-------------------

Ridgeline

V6 3.5L	VO-106	VA-210	VCA-1063	NS ⁴³⁷
---------	--------	--------	----------	-------------------

2009

Accord

4 cyl. 2.4L FI	VO-106	VA-221	VCA-1063	NS ⁴³⁷
----------------	--------	--------	----------	-------------------

V6 3.5L FI	VO-106	VA-220	VCA-1063	NS ⁴³⁷
------------	--------	--------	----------	-------------------

Civic

4 cyl. 1.8L FI CNG	VO-106	VA-212	VCA-1063	NS ⁴³⁷
--------------------	--------	--------	----------	-------------------

4 cyl. 1.8L FI GAS	VO-106	VA-212	VCA-1063	NS ⁴³⁷
--------------------	--------	--------	----------	-------------------

Civic Hybrid

4 cyl. 1.3L Hybrid	VO-106	VA-343	VCA-1063	NS ⁴³⁷
--------------------	--------	--------	----------	-------------------

Civic Si

4 cyl. 2.0L FI	VO-106	VA-237	VCA-1063	NS ⁴³⁷
----------------	--------	--------	----------	-------------------

CR-V

4 cyl. 2.4L FI	VO-106	VA-252	VCA-1063	NS ⁴³⁷
----------------	--------	--------	----------	-------------------

Element

4 cyl. 2.4L FI	VO-106	VA-237	VCA-1012	NS ⁴³⁷
----------------	--------	--------	----------	-------------------

FIT

4 cyl. 1.5L	VO-106	VA-250	VCA-1061	NS ⁴³⁷
-------------	--------	--------	----------	-------------------

Odyssey

V6 3.5L	VO-106	VA-202	VCA-1063	NS ⁴³⁷
---------	--------	--------	----------	-------------------

Pilot

V6 3.5L FI	VO-106	VA-202	VCA-1063	NS ⁴³⁷
------------	--------	--------	----------	-------------------

Ridgeline

V6 3.5L FI	VO-106	VA-210	VCA-1063	NS ⁴³⁷
------------	--------	--------	----------	-------------------

S2000

4 cyl. 2.2L FI	VO-106			NS ⁴³⁷
----------------	--------	--	--	-------------------

2008

Accord

4 cyl. 2.4L FI	VO-106	VA-221	VCA-1063	NS ⁴³⁷
----------------	--------	--------	----------	-------------------

V6 3.5L FI	VO-106	VA-220	VCA-1063	NS ⁴³⁷
------------	--------	--------	----------	-------------------

Civic

4 cyl. 1.8L FI (CNG)	VO-106	VA-212	VCA-1063	
----------------------	--------	--------	----------	--

4 cyl. 1.8L FI GAS	VO-106	VA-212	VCA-1063	NS ⁴³⁷
--------------------	--------	--------	----------	-------------------

Civic Hybrid

4 cyl. 1.3L Hybrid	VO-106	VA-343	VCA-1063	NS ⁴³⁷
--------------------	--------	--------	----------	-------------------

Civic Si

4 cyl. 2.0L FI	VO-106	VA-237	VCA-1063	NS ⁴³⁷
----------------	--------	--------	----------	-------------------

CR-V

4 cyl. 2.4L FI	VO-106	VA-252	VCA-1063	NS ⁴³⁷
----------------	--------	--------	----------	-------------------

Se reporter à table de matière pour les notes en bas de page en français. Utilize el contenido para ver notas a pie.

NS - Non-Serviceable / Non réparable / No reparable LF - Life-Time Filter / Filtro para toda la vida / Filtre à vie

⁴³⁷ Requires replacement of the complete fuel pump/fuel filter module.



HONDA (cont'd)

Model	Oil	Air	Cabin*	Fuel
2008				
Element				
4 cyl. 2.4L FI	VO-106	VA-237	VCA-1012	NS ⁴³⁷
FIT				
4 cyl. 1.5L	VO-106	VA-242	VCA-1110	NS ⁴³⁷
Odyssey				
V6 3.5L	VO-106	VA-202	VCA-1063	NS ⁴³⁷
Pilot				
V6 3.5L FI	VO-106	VA-192	VCA-1013	NS ⁴³⁷
Ridgeline				
V6 3.5L FI	VO-106	VA-210	VCA-1063	NS ⁴³⁷
S2000				
4 cyl. 2.2L FI	VO-106			NS ⁴³⁷
2007				
Accord				
4 cyl. 2.4L FI	VO-106	VA-183	VCA-1063	NS ⁴³⁷
V6 3.0L FI	VO-106	VA-184	VCA-1063	NS ⁴³⁷
V6 3.0L Hybrid	VO-106	VA-184	VCA-1063	NS ⁴³⁷
Civic				
4 cyl. 1.8L FI (CNG)	VO-106	VA-212	VCA-1063	
4 cyl. 1.8L FI GAS	VO-106	VA-212	VCA-1063	NS ⁴³⁷
Civic Hybrid				
4 cyl. 1.3L Hybrid	VO-106	VA-343	VCA-1063	NS ⁴³⁷
Civic Si				
4 cyl. 2.0L FI	VO-106	VA-237	VCA-1063	NS ⁴³⁷
CR-V				
4 cyl. 2.4L FI	VO-106	VA-252	VCA-1063	NS ⁴³⁷
Element				
4 cyl. 2.4L FI	VO-106	VA-237	VCA-1012	NS ⁴³⁷
FIT				
4 cyl. 1.5L	VO-106	VA-242	VCA-1110	NS ⁴³⁷
Odyssey				
V6 3.5L	VO-106	VA-202	VCA-1063	NS ⁴³⁷
Pilot				
V6 3.5L FI	VO-106	VA-192	VCA-1013	NS ⁴³⁷
Ridgeline				
V6 3.5L FI	VO-106	VA-210	VCA-1063	NS ⁴³⁷
S2000				
4 cyl. 2.2L FI	VO-106			NS ⁴³⁷
2006				
Accord				
4 cyl. 2.4L FI	VO-106	VA-183	VCA-1063	NS ⁴³⁷
V6 3.0L FI	VO-106	VA-184	VCA-1063	NS ⁴³⁷
V6 3.0L Hybrid	VO-106	VA-184	VCA-1063	NS ⁴³⁷
Civic				
4 cyl. 1.8L FI (CNG)	VO-106	VA-212	VCA-1012	
4 cyl. 1.8L FI GAS	VO-106	VA-212	VCA-1063	NS ⁴³⁷
Civic Hybrid				
4 cyl. 1.3L Hybrid	VO-106	VA-343	VCA-1063	NS ⁴³⁷
Civic Si				
4 cyl. 2.0L FI	VO-106	VA-237	VCA-1063	NS ⁴³⁷
CR-V				
4 cyl. 2.4L FI	VO-106	VA-196	VCA-1012	NS ⁴³⁷

Se reporter à table de matière pour les notes en bas de page en français. Utilize el contenido para ver notas a pie.

NS - Non-Serviceable / Non réparable / No reparable LF - Life-Time Filter / Filtro para toda la vida / Filtre à vie

⁴³⁷ Requires replacement of the complete fuel pump/fuel filter module.



HONDA (cont'd)

2006

Element

4 cyl. 2.4L FI	VO-106	VA-196	VCA-1012	NS ⁴³⁷
----------------	--------	--------	----------	-------------------

Insight

3 cyl. 1.0L FI (Hybrid)	VO-106		VCA-1122	NS ⁴³⁷
-------------------------	--------	--	----------	-------------------

Odyssey

V6 3.5L	VO-106	VA-202	VCA-1063	NS ⁴³⁷
---------	--------	--------	----------	-------------------

Pilot

V6 3.5L FI	VO-106	VA-192	VCA-1013	NS ⁴³⁷
------------	--------	--------	----------	-------------------

Ridgeline

V6 3.5L FI	VO-106	VA-210	VCA-1063	NS ⁴³⁷
------------	--------	--------	----------	-------------------

S2000

4 cyl. 2.2L FI	VO-106			NS ⁴³⁷
----------------	--------	--	--	-------------------

2005

Accord

4 cyl. 2.4L FI	VO-106	VA-183	VCA-1063	NS ⁴³⁷
----------------	--------	--------	----------	-------------------

V6 3.0L FI	VO-106	VA-184	VCA-1063	NS ⁴³⁷
------------	--------	--------	----------	-------------------

V6 3.0L Hybrid	VO-106	VA-184	VCA-1063	NS ⁴³⁷
----------------	--------	--------	----------	-------------------

Civic

4 cyl. 1.7L FI (CNG)	VO-106	VA-165	VCA-1012	
----------------------	--------	--------	----------	--

4 cyl. 1.7L FI GAS	VO-106	VA-165	VCA-1012	NS ⁴³⁷
--------------------	--------	--------	----------	-------------------

Civic Hybrid

4 cyl. 1.3L Hybrid	VO-106	VA-328	VCA-1012	NS ⁴³⁷
--------------------	--------	--------	----------	-------------------

Civic Si

4 cyl. 2.0L FI	VO-106	VA-196	VCA-1012	NS ⁴³⁷
----------------	--------	--------	----------	-------------------

CR-V

4 cyl. 2.4L FI	VO-106	VA-196	VCA-1012	NS ⁴³⁷
----------------	--------	--------	----------	-------------------

Element

4 cyl. 2.4L FI	VO-106	VA-196	VCA-1012	NS ⁴³⁷
----------------	--------	--------	----------	-------------------

Insight

3 cyl. 1.0L FI (Hybrid)	VO-106		VCA-1122	NS ⁴³⁷
-------------------------	--------	--	----------	-------------------

Odyssey

V6 3.5L	VO-106	VA-202	VCA-1063	NS ⁴³⁷
---------	--------	--------	----------	-------------------

Pilot

V6 3.5L FI	VO-106	VA-192	VCA-1013	NS ⁴³⁷
------------	--------	--------	----------	-------------------

S2000

4 cyl. 2.2L FI	VO-106			NS ⁴³⁷
----------------	--------	--	--	-------------------

2004

Accord

4 cyl. 2.4L FI	VO-106	VA-183	VCA-1063	NS ⁴³⁷
----------------	--------	--------	----------	-------------------

V6 3.0L FI	VO-106	VA-184	VCA-1063	NS ⁴³⁷
------------	--------	--------	----------	-------------------

Civic

4 cyl. 1.7L FI (CNG)	VO-106	VA-165	VCA-1012	
----------------------	--------	--------	----------	--

4 cyl. 1.7L FI GAS	VO-106	VA-165	VCA-1012	NS ⁴³⁷
--------------------	--------	--------	----------	-------------------

Civic Hybrid

4 cyl. 1.3L Hybrid	VO-106	VA-328	VCA-1012	NS ⁴³⁷
--------------------	--------	--------	----------	-------------------

Civic Si

4 cyl. 2.0L FI	VO-106	VA-196	VCA-1012	NS ⁴³⁷
----------------	--------	--------	----------	-------------------

CR-V

4 cyl. 2.4L FI	VO-106	VA-196	VCA-1012	NS ⁴³⁷
----------------	--------	--------	----------	-------------------

Element

4 cyl. 2.4L FI	VO-106	VA-196	VCA-1012	NS ⁴³⁷
----------------	--------	--------	----------	-------------------

Se reporter à table de matière pour les notes en bas de page en français. Utilize el contenido para ver notas a pie.

NS - Non-Serviceable / Non réparable / No reparable LF - Life-Time Filter / Filtro para toda la vida / Filtre à vie

⁴³⁷ Requires replacement of the complete fuel pump/fuel filter module.



HONDA (cont'd)

	Oil	Air	Cabin*	Fuel
2004				
Insight				
3 cyl. 1.0L FI (Hybrid)	VO-106		VCA-1122	NS ⁴³⁷
Odyssey				
V6 3.5L	VO-106	VA-270	VCA-1013	NS ⁴³⁷
Pilot				
V6 3.5L FI	VO-106	VA-192	VCA-1013	NS ⁴³⁷
S2000				
4 cyl. 2.2L FI	VO-106			NS ⁴³⁷
2003				
Accord				
4 cyl. 2.4L FI	VO-106	VA-183	VCA-1063	NS ⁴³⁷
V6 3.0L FI	VO-106	VA-184	VCA-1063	NS ⁴³⁷
Civic				
4 cyl. 1.7L FI (CNG)	VO-106	VA-165	VCA-1012	NS ⁴³⁷
4 cyl. 1.7L FI GAS	VO-106	VA-165	VCA-1012	
Civic Hybrid				
4 cyl. 1.3L Hybrid	VO-106	VA-328	VCA-1012	NS ⁴³⁷
Civic Si				
4 cyl. 2.0L FI	VO-106	VA-196	VCA-1012	NS ⁴³⁷
CR-V				
4 cyl. 2.4L FI	VO-106	VA-196	VCA-1012	NS ⁴³⁷
Element				
4 cyl. 2.4L FI	VO-106	VA-196	VCA-1012	NS ⁴³⁷
Insight				
3 cyl. 1.0L FI (Hybrid)	VO-106		VCA-1122	NS ⁴³⁷
Odyssey				
V6 3.5L	VO-106	VA-270	VCA-1013	NS ⁴³⁷
Pilot				
V6 3.5L FI	VO-106	VA-192	VCA-1013	NS ⁴³⁷
S2000				
4 cyl. 2.0L FI	VO-106			NS ⁴³⁷
2002				
Accord				
4 cyl. 2.3L FI	VO-106	VA-117	VCA-1167	NS ⁴³⁷
V6 3.0L FI	VO-106	VA-118	VCA-1167	NS ⁴³⁷
Civic				
4 cyl. 1.7L FI (CNG)	VO-106	VA-165	VCA-1012	NS ⁴³⁷
4 cyl. 1.7L FI GAS	VO-106	VA-165	VCA-1012	
Civic Si				
4 cyl. 2.0L FI	VO-106	VA-196	VCA-1012	NS ⁴³⁷
CR-V				
4 cyl. 2.4L FI	VO-106	VA-196	VCA-1012	NS ⁴³⁷
Insight				
3 cyl. 1.0L FI (Hybrid)	VO-106		VCA-1122	NS ⁴³⁷
Odyssey				
V6 3.5L	VO-106	VA-270	VCA-1013	NS ⁴³⁷
Passport				
V6 3.2L FI	VO-106	VFAP-7859		
S2000				
4 cyl. 2.0L FI	VO-106			NS ⁴³⁷

Se reporter à table de matière pour les notes en bas de page en français. Utilize el contenido para ver notas a pie.

NS - Non-Serviceable / Non réparable / No reparable LF - Life-Time Filter / Filtro para toda la vida / Filtre à vie

⁴³⁷ Requires replacement of the complete fuel pump/fuel filter module.



HONDA (cont'd)

2001

Accord

4 cyl. 2.3L FI	VO-106	VA-117	VCA-1167	NS ⁴³⁷
V6 3.0L FI	VO-106	VA-118	VCA-1167	NS ⁴³⁷

Civic

4 cyl. 1.7L FI (CNG)	VO-106	VA-165	VCA-1012	
4 cyl. 1.7L FI GAS	VO-106	VA-165	VCA-1012	NS ⁴³⁷

CR-V

4 cyl. 2.0L FI	VO-106	VA-135	VCA-1122	
----------------	--------	--------	----------	--

Insight

3 cyl. 1.0L FI (Hybrid)	VO-106		VCA-1122	NS ⁴³⁷
-------------------------	--------	--	----------	-------------------

Odyssey

V6 3.5L	VO-106	VA-270	VCA-1013	NS ⁴³⁷
---------	--------	--------	----------	-------------------

Passport

V6 3.2L FI	VO-106	VFAP-7859		
------------	--------	-----------	--	--

Prelude

4 cyl. 2.2L FI (VTEC)	VO-106			
-----------------------	--------	--	--	--

S2000

4 cyl. 2.0L FI	VO-106			NS ⁴³⁷
----------------	--------	--	--	-------------------

2000

Accord

4 cyl. 2.3L FI	VO-106	VA-117	VCA-1167	NS ⁴³⁷
V6 3.0L FI	VO-106	VA-118	VCA-1167	NS ⁴³⁷

Civic CX, DX, LX

4 cyl. 1.6L FI	VO-106	VFAP-7908		
----------------	--------	-----------	--	--

Civic EX, HX

4 cyl. 1.6L FI (VTEC)	VO-106	VA-135		
-----------------------	--------	--------	--	--

Civic GX

4 cyl. 1.6L FI (CNG)	VO-106	VA-135		
----------------------	--------	--------	--	--

Civic Si

4 cyl. 1.6L FI DOHC (VTEC)	VO-106	VA-135		
----------------------------	--------	--------	--	--

CR-V

4 cyl. 2.0L FI	VO-106	VA-135	VCA-1122	
----------------	--------	--------	----------	--

Insight

3 cyl. 1.0L FI (Hybrid)	VO-106		VCA-1122	NS ⁴³⁷
-------------------------	--------	--	----------	-------------------

Odyssey

V6 3.5L	VO-106	VA-270	VCA-1013	NS ⁴³⁷
---------	--------	--------	----------	-------------------

Passport

V6 3.2L FI	VO-106	VFAP-7859		
------------	--------	-----------	--	--

Prelude

4 cyl. 2.2L FI (VTEC)	VO-106			
-----------------------	--------	--	--	--

S2000

4 cyl. 2.0L FI	VO-106			NS ⁴³⁷
----------------	--------	--	--	-------------------

1999

Accord

4 cyl. 2.3L FI	VO-106	VA-117	VCA-1167	NS ⁴³⁷
V6 3.0L FI	VO-106	VA-118	VCA-1167	NS ⁴³⁷

Civic CX, DX, LX

4 cyl. 1.6L FI	VO-106	VFAP-7908		
----------------	--------	-----------	--	--

Civic EX, HX

4 cyl. 1.6L FI SOHC (VTEC)	VO-106	VA-135		
----------------------------	--------	--------	--	--

Civic GX

4 cyl. 1.6L FI (CNG)	VO-106	VA-135		
----------------------	--------	--------	--	--

Se reporter à table de matière pour les notes en bas de page en français. Utilize el contenido para ver notas a pie.
 NS - Non-Serviceable / Non réparable / No reparable LF - Life-Time Filter / Filtro para toda la vida / Filtre à vie

⁴³⁷ Requires replacement of the complete fuel pump/fuel filter module.



HONDA (cont'd)

	Oil	Air	Cabin*	Fuel
1999				
Civic Si				
4 cyl. 1.6L FI DOHC (VTEC)	VO-106	VA-135		
CR-V				
4 cyl. 2.0L FI	VO-106	VA-135	VCA-1122	
Odyssey				
V6 3.5L	VO-106	VA-270	VCA-1013	NS ⁴³⁷
Passport				
V6 3.2L FI	VO-106	VFAP-7859		
Prelude				
4 cyl. 2.2L FI (VTEC)	VO-106			
1998				
Accord				
4 cyl. 2.3L FI	VO-106	VA-117	VCA-1167	NS ⁴³⁷
V6 3.0L FI	VO-106	VA-118	VCA-1167	NS ⁴³⁷
Civic CX, DX, LX				
4 cyl. 1.6L FI	VO-106	VFAP-7908		
Civic EX, HX				
4 cyl. 1.6L FI (VTEC)	VO-106	VA-135		
Civic GX				
4 cyl. 1.6L FI (CNG)	VO-106	VA-135		
CR-V				
4 cyl. 2.0L FI	VO-106	VA-135	VCA-1122	
Odyssey				
4 cyl. 2.3L FI	VO-106	VA-113		
Passport				
V6 3.2L FI	VO-106	VFAP-7859		
Prelude				
4 cyl. 2.2L FI (VTEC)	VO-106			
1997				
Accord				
4 cyl. 2.2L FI	VO-106	VA-113		
V6 2.7L FI	VO-106			
Civic CX, DX, LX				
4 cyl. 1.6L FI	VO-106	VFAP-7908		
Civic EX, HX				
4 cyl. 1.6L FI (VTEC)	VO-106	VA-135		
Civic Si (Canada)				
4 cyl. 1.6L FI	VO-106	VA-135		
CR-V				
4 cyl. 2.0L FI	VO-106	VA-135	VCA-1122	
Del Sol				
4 cyl. 1.6L FI (S Model)	VO-106	VFAP-7908		
4 cyl. 1.6L FI (Si)	VO-106	VFAP-7908		
4 cyl. 1.6L FI DOHC (VTEC)	VO-106	VA-103		
Odyssey				
4 cyl. 2.2L FI	VO-106	VA-113		
Passport				
V6 3.2L FI	VO-106	VFAP-7859		
Prelude				
4 cyl. 2.2L FI (VTEC)	VO-106			

Se reporter à table de matière pour les notes en bas de page en français. Utilize el contenido para ver notas a pie.

NS - Non-Serviceable / Non réparable / No repairable LF - Life-Time Filter / Filtro para toda la vida / Filtre à vie

⁴³⁷ Requires replacement of the complete fuel pump/fuel filter module.



HONDA (cont'd)

1996

Accord

4 cyl. 2.2L FI	VO-106	VA-113		
V6 2.7L FI	VO-106			

Civic CX, DX, LX

4 cyl. 1.6L FI	VO-106	VFAP-7908		
----------------	--------	-----------	--	--

Civic EX, HX

4 cyl. 1.6L FI (VTEC)	VO-106	VA-135		
-----------------------	--------	--------	--	--

Civic Si (Canada)

4 cyl. 1.6L FI	VO-106	VA-135		
----------------	--------	--------	--	--

Del Sol

4 cyl. 1.6L FI (S Model)	VO-106	VFAP-7908		
4 cyl. 1.6L FI (Si)	VO-106	VFAP-7908		
4 cyl. 1.6L FI DOHC (VTEC)	VO-106	VA-103		

Odyssey

4 cyl. 2.2L FI	VO-106	VA-113		
----------------	--------	--------	--	--

Passport

4 cyl. 2.6L FI	VO-106			
V6 3.2L FI	VO-106	VFAP-7859		

Prelude

4 cyl. 2.2L FI	VO-106			
4 cyl. 2.3L FI	VO-106			

1995

Accord

4 cyl. 2.2L FI	VO-106	VA-113		
V6 2.7L FI	VO-106			

Civic CX, VX

4 cyl. 1.5L FI	VO-106	VA-103		
----------------	--------	--------	--	--

Civic DX, LX

4 cyl. 1.5L FI	VO-106	VA-103		
----------------	--------	--------	--	--

Civic EX, SI

4 cyl. 1.6L FI	VO-106	VA-103		
----------------	--------	--------	--	--

Del Sol

4 cyl. 1.5L FI	VO-106	VA-103		
4 cyl. 1.6L FI (Si)	VO-106	VA-103		
4 cyl. 1.6L FI (VTEC)	VO-106	VA-103		

Odyssey

4 cyl. 2.2L FI	VO-106	VA-113		
----------------	--------	--------	--	--

Passport

4 cyl. 2.6L FI	VO-106	VA-408		
V6 3.2L FI	VO-106	VFAP-7859		

Prelude

4 cyl. 2.2L FI	VO-106			
4 cyl. 2.3L FI	VO-106			

HUMMER

2010

H3

5 cyl 3.7L (E) FI	VO-108	VA-219		NS ⁴³⁷
V8 5.3L (P) FI	VO-88	VA-219		NS ⁴³⁷

2009

H2

V8 6.2L FI (Flex Fuel)	VO-88	VA-187		NS ⁴³⁷
------------------------	-------	--------	--	-------------------

Se reporter à table de matière pour les notes en bas de page en français. Utilize el contenido para ver notas a pie.

NS - Non-Serviceable / Non réparable / No reparable LF - Life-Time Filter / Filtro para toda la vida / Filtre à vie

⁴³⁷ Requires replacement of the complete fuel pump/fuel filter module.



HUMMER (cont'd)

	Oil	Air	Cabin*	Fuel
2009				
H3				
5 cyl 3.7L (E) FI	VO-108	VA-219		NS ⁴³⁷
V8 5.3L (L) FI	VO-88	VA-219		NS ⁴³⁷
2008				
H2				
V8 6.2L FI	VO-88	VA-187		NS ⁴³⁷
H3				
5 cyl 3.7L (E) FI	VO-108	VA-219		NS ⁴³⁷
V8 5.3L (L) FI	VO-88	VA-219		NS ⁴³⁷
2007				
H2				
V8 6.0L (U) FI	VO-88	VA-187		NS ⁴³⁷
H3				
5 cyl 3.7L (E) FI	VO-108	VA-181		NS ⁴³⁷
2006				
H1				
V8 6.6L Diesel Turbo	VO-75			
H2				
V8 6.0L (U) FI	VO-58	VA-187		NS ⁴³⁷
H3				
5 cyl 3.5L (6) FI	VO-108	VA-181		NS ⁴³⁷
2005				
H2				
V8 6.0L (U) FI	VO-58	VA-187	VCA-1074 ^{X628} VCA-1169 ^{Z628}	NS ⁴³⁷
2004				
H1				
V8 6.5L Diesel Turbo	VO-56			
H2				
V8 6.0L (U) FI	VO-58	VA-187	VCA-1074 ^{X628} VCA-1169 ^{Z628}	NS ⁴³⁷
2003				
H1				
V8 6.5L Diesel Turbo	VO-56			
H2				
V8 6.0L (U) FI	VO-58	VA-187	VCA-1074 ^{X628} VCA-1169 ^{Z628}	
2002				
H1				
V8 6.5L Diesel Turbo	VO-56			
2001				
Hummer				
V8 6.5L (Z) Diesel Turbo	VO-56			
2000				
Hummer				
V8 6.5L (Z) Diesel Turbo	VO-56			
1999				
Hummer				
V8 6.5L (Z) Diesel Turbo	VO-56			

Se reporter à table de matière pour les notes en bas de page en français. Utilize el contenido para ver notas a pie.

NS - Non-Serviceable / Non réparable / No reparable LF - Life-Time Filter / Filtro para toda la vida / Filtre à vie

⁴³⁷ Requires replacement of the complete fuel pump/fuel filter module. ^{X628}Dust and odor. ^{Z628}Dust filter.



HUMMER (cont'd)

1998

Hummer

V8 6.5L (Z) Diesel Turbo	VO-56			
V8 6.5L (Y) FI Diesel	VO-56			

1997

Hummer

V8 6.5L (Z) Diesel Turbo	VO-56			
V8 6.5L (Y) FI Diesel	VO-56			

1996

Hummer

V8 5.7L (D) FI	VO-55			VG-14
V8 6.5L (Z) Diesel Turbo	VO-56			
V8 6.5L (Y) FI Diesel	VO-56			

1995

Hummer

V8 5.7L (D) FI	VO-55			VG-14
V8 6.5L (Y) FI Diesel	VO-56			

1994

Hummer

V8 6.5L (Y) FI Diesel	VO-56			
-----------------------	-------	--	--	--

HYUNDAI

2019

Accent

4 cyl. 1.6L	VO-106		VCA-1191	NS ⁴³⁷
-------------	--------	--	----------	-------------------

Elantra

4 cyl. 1.4L Turbo	VO-106	VA-465	VCA-1191	NS ⁴³⁷
4 cyl. 1.6L Turbo	VO-106	VA-465	VCA-1191	NS ⁴³⁷
4 cyl. 2.0L	VO-148	VA-465	VCA-1191	NS ⁴³⁷

Ioniq

4 cyl. 1.6L Hybrid	VO-106			NS ⁴³⁷
--------------------	--------	--	--	-------------------

Kona

4 cyl. 1.6L Turbo	VO-106	VA-465		
4 cyl. 2.0L	VO-148	VA-465		

Santa Fe

4 cyl. 2.0L Turbo	VO-148	VA-418	VCA-1062	NS ⁴³⁷
4 cyl. 2.4L	VO-106	VA-418	VCA-1062	NS ⁴³⁷

Santa Fe XL

V6 3.3L	VO-109	VA-311	VCA-1075	NS ⁴³⁷
---------	--------	--------	----------	-------------------

Sonata

4 cyl. 1.6L Turbo	VO-106		VCA-1181	NS ⁴³⁷
4 cyl 2.0L Turbo	VO-148		VCA-1181	NS ⁴³⁷
4 cyl. 2.0L Hybrid	VO-106	VA-417	VCA-1181	NS ⁴³⁷
4 cyl 2.4L	VO-106	VA-417	VCA-1181	NS ⁴³⁷

Tucson

4 cyl 2.0L	VO-106	VA-458	VCA-1190	NS ⁴³⁷
4 cyl 2.4L	VO-106	VA-458	VCA-1190	NS ⁴³⁷

Veloster

4 cyl. 1.6L Turbo	VO-106	VA-465	VCA-1190	NS ⁴³⁷
4 cyl. 2.0L	VO-106	VA-465	VCA-1190	NS ⁴³⁷

Veloster N

4 cyl. 2.0L Turbo	VO-106		VCA-1190	NS ⁴³⁷
-------------------	--------	--	----------	-------------------

Se reporter à table de matière pour les notes en bas de page en français. Utilize el contenido para ver notas a pie.

NS - Non-Serviceable / Non réparable / No reparable LF - Life-Time Filter / Filtro para toda la vida / Filtre à vie

⁴³⁷ Requires replacement of the complete fuel pump/fuel filter module.



HYUNDAI (cont'd)

	Oil	Air	Cabin*	Fuel
2018				
Accent				
4 cyl. 1.6L	VO-106		VCA-1191	NS ⁴³⁷
Elantra				
4 cyl. 1.4L Turbo	VO-148	VA-465	VCA-1191	NS ⁴³⁷
4 cyl. 1.6L Turbo	VO-106	VA-465	VCA-1191	NS ⁴³⁷
4 cyl. 2.0L	VO-148	VA-465	VCA-1191	NS ⁴³⁷
Ioniq				
4 cyl. 1.6L Hybrid	VO-106			NS ⁴³⁷
Kona				
4 cyl. 1.6L Turbo	VO-106	VA-465		
4 cyl. 2.0L	VO-148	VA-465		
Santa Fe				
V6 3.3L	VO-109	VA-311	VCA-1075	NS ⁴³⁷
Santa Fe Sport				
4 cyl. 2.0L Turbo	VO-148	VA-418	VCA-1075	NS ⁴³⁷
4 cyl. 2.4L	VO-106	VA-418	VCA-1075	NS ⁴³⁷
Santa Fe XL				
V6 3.3L	VO-109	VA-311	VCA-1075	NS ⁴³⁷
Sonata				
4 cyl. 1.6L Turbo	VO-106		VCA-1181	NS ⁴³⁷
4 cyl. 2.0L Turbo	VO-148		VCA-1181	NS ⁴³⁷
4 cyl. 2.0L Hybrid	VO-148	VA-417	VCA-1181	NS ⁴³⁷
4 cyl. 2.4L	VO-106	VA-417	VCA-1181	NS ⁴³⁷
Tucson				
4 cyl. 1.6L Turbo	VO-106	VA-458	VCA-1190	NS ⁴³⁷
4 cyl. 2.0L	VO-148	VA-458	VCA-1190	NS ⁴³⁷
4 cyl. 2.4L	VO-106	VA-458	VCA-1190	NS ⁴³⁷
2017				
Accent				
4 cyl. 1.6L	VO-106	VA-300	VCA-1047	NS ⁴³⁷
Azera				
V6 3.3L	VO-109	VA-265	VCA-1075	NS ⁴³⁷
Elantra				
4 cyl. 1.4L Turbo	VO-148	VA-465	VCA-1191	NS ⁴³⁷
4 cyl. 1.6L Turbo	VO-106	VA-465	VCA-1191	NS ⁴³⁷
4 cyl. 2.0L	VO-148	VA-465	VCA-1191	NS ⁴³⁷
Ioniq				
4 cyl. 1.6L Hybrid	VO-106			NS ⁴³⁷
Santa Fe				
V6 3.3L	VO-109	VA-311	VCA-1075	NS ⁴³⁷
Santa Fe Sport				
4 cyl. 2.0L Turbo	VO-148	VA-418	VCA-1075	NS ⁴³⁷
4 cyl. 2.4L	VO-106	VA-418	VCA-1075	NS ⁴³⁷
Santa Fe XL				
V6 3.3L	VO-109	VA-311	VCA-1075	NS ⁴³⁷
Sonata				
4 cyl. 1.6L Turbo	VO-106		VCA-1181	NS ⁴³⁷
4 cyl. 2.0L Turbo	VO-148		VCA-1181	NS ⁴³⁷
4 cyl. 2.0L Hybrid	VO-148	VA-417	VCA-1181	NS ⁴³⁷
4 cyl. 2.4L	VO-106	VA-417	VCA-1181	NS ⁴³⁷
Tucson				
4 cyl. 1.6L Turbo	VO-106	VA-458	VCA-1190	NS ⁴³⁷

Se reporter à table de matière pour les notes en bas de page en français. Utilize el contenido para ver notas a pie.

NS - Non-Serviceable / Non réparable / No reparable LF - Life-Time Filter / Filtro para toda la vida / Filtre à vie

⁴³⁷ Requires replacement of the complete fuel pump/fuel filter module.



HYUNDAI (cont'd)

2017

Tucson

4 cyl. 2.0L	VO-148	VA-458	VCA-1190	NS ⁴³⁷
-------------	--------	--------	----------	-------------------

Veloster

4 cyl. 1.6L	VO-106	VA-300	VCA-1047	NS ⁴³⁷
4 cyl. 1.6L Turbo	VO-106	VA-300	VCA-1047	NS ⁴³⁷

2016

Accent

4 cyl. 1.6L	VO-106	VA-300	VCA-1047	NS ⁴³⁷
-------------	--------	--------	----------	-------------------

Azera

V6 3.3L	VO-109	VA-265	VCA-1075	NS ⁴³⁷
---------	--------	--------	----------	-------------------

Elantra

4 cyl. 1.8L	VO-148	VA-334	VCA-1051	NS ⁴³⁷
4 cyl. 2.0L	VO-148	VA-334	VCA-1051	NS ⁴³⁷

Equus

V8 5.0L	VO-99	VA-358	VCA-1062	NS ⁴³⁷
---------	-------	--------	----------	-------------------

Genesis

V6 3.8L	VO-167		VCA-1062	NS ⁴³⁷
V8 5.0L			VCA-1062	NS ⁴³⁷

Genesis Coupe

V6 3.8L	VO-99	VA-331	VCA-1047	NS ⁴³⁷
---------	-------	--------	----------	-------------------

Santa Fe

V6 3.3L	VO-109	VA-311	VCA-1075	NS ⁴³⁷
---------	--------	--------	----------	-------------------

Santa Fe Sport

4 cyl. 2.0L Turbo	VO-148	VA-311 ^{X903} VA-418 ^{Z903}	VCA-1075	NS ⁴³⁷
4 cyl. 2.4L	VO-106	VA-311	VCA-1075	NS ⁴³⁷

Santa Fe XL

V6 3.3L	VO-109	VA-311	VCA-1075	NS ⁴³⁷
---------	--------	--------	----------	-------------------

Sonata

4 cyl. 1.6L Turbo	VO-106		VCA-1181	NS ⁴³⁷
4 cyl. 2.0L Turbo	VO-148		VCA-1181	NS ⁴³⁷
4 cyl. 2.0L Hybrid	VO-148	VA-417	VCA-1181	NS ⁴³⁷
4 cyl. 2.4L	VO-106	VA-417	VCA-1181	NS ⁴³⁷

Tucson

4 cyl. 1.6L	VO-106	VA-458	VCA-1190	NS ⁴³⁷
4 cyl. 2.0L	VO-148	VA-458	VCA-1190	NS ⁴³⁷

Veloster

4 cyl. 1.6L	VO-106	VA-300	VCA-1047	NS ⁴³⁷
4 cyl. 1.6L Turbo	VO-106	VA-300	VCA-1047	NS ⁴³⁷

2015

Accent

4 cyl. 1.6L	VO-106	VA-300	VCA-1047	NS ⁴³⁷
-------------	--------	--------	----------	-------------------

Azera

V6 3.3L	VO-109	VA-265	VCA-1075	NS ⁴³⁷
---------	--------	--------	----------	-------------------

Elantra

4 cyl. 1.8L	VO-148	VA-334	VCA-1051	NS ⁴³⁷
4 cyl. 2.0L	VO-148	VA-334	VCA-1051	NS ⁴³⁷

Equus

V8 5.0L	VO-99	VA-358	VCA-1062	NS ⁴³⁷
---------	-------	--------	----------	-------------------

Genesis

V6 3.8L	VO-167		VCA-1062	NS ⁴³⁷
V8 5.0L			VCA-1062	NS ⁴³⁷

Se reporter à table de matière pour les notes en bas de page en français. Utilize el contenido para ver notas a pie.

NS - Non-Serviceable / Non réparable / No reparable LF - Life-Time Filter / Filtro para toda la vida / Filtre à vie

⁴³⁷ Requires replacement of the complete fuel pump/fuel filter module. ^{X903} before product date 11/25/2015 ^{Z903} 11/25/2015 on



HYUNDAI (cont'd)

	Oil	Air	Cabin*	Fuel
2015				
Genesis Coupe				
V6 3.8L	VO-99	VA-331	VCA-1047	NS ⁴³⁷
Santa Fe				
V6 3.3L	VO-109	VA-311	VCA-1075	NS ⁴³⁷
Santa Fe Sport				
4 cyl. 2.0L Turbo	VO-148	VA-311	VCA-1075	NS ⁴³⁷
4 cyl. 2.4L	VO-106	VA-311	VCA-1075	NS ⁴³⁷
Santa Fe XL				
V6 3.3L	VO-109	VA-311	VCA-1075	NS ⁴³⁷
Sonata				
4 cyl. 1.6L Turbo	VO-106		VCA-1181	NS ⁴³⁷
4 cyl. 2.0L Turbo	VO-148		VCA-1181	NS ⁴³⁷
4 cyl. 2.4L	VO-106	VA-417	VCA-1181	NS ⁴³⁷
4 cyl. 2.4L Hybrid	VO-106	VA-265	VCA-1075	NS ⁴³⁷
Tucson				
4 cyl. 2.0L	VO-148	VA-283	VCA-1047	NS ⁴³⁷
4 cyl. 2.4L	VO-106	VA-283	VCA-1047	NS ⁴³⁷
Veloster				
4 cyl. 1.6L	VO-106	VA-300	VCA-1047	NS ⁴³⁷
4 cyl. 1.6L Turbo	VO-106	VA-300	VCA-1047	NS ⁴³⁷
2014				
Accent				
4 cyl. 1.6L	VO-106	VA-300	VCA-1047	NS ⁴³⁷
Azera				
V6 3.3L	VO-109	VA-265	VCA-1075	NS ⁴³⁷
Elantra				
4 cyl. 1.8L	VO-148	VA-334	VCA-1051	NS ⁴³⁷
4 cyl. 2.0L	VO-148	VA-334	VCA-1051	NS ⁴³⁷
Equus				
V8 5.0L	VO-99	VA-358	VCA-1062	NS ⁴³⁷
Genesis				
V6 3.8L	VO-99	VA-358	VCA-1062	NS ⁴³⁷
V8 5.0L	VO-99	VA-358	VCA-1062	NS ⁴³⁷
Genesis Coupe				
4 cyl. 2.0L Turbo	VO-148	VA-392	VCA-1047	NS
V6 3.8L	VO-99	VA-331	VCA-1047	NS ⁴³⁷
Santa Fe				
V6 3.3L	VO-109	VA-311	VCA-1075	NS ⁴³⁷
Santa Fe Sport				
4 cyl. 2.0L Turbo	VO-148	VA-311	VCA-1075	NS ⁴³⁷
4 cyl. 2.4L	VO-106	VA-311	VCA-1075	NS ⁴³⁷
Santa Fe XL				
V6 3.3L	VO-109	VA-311	VCA-1075	NS ⁴³⁷
Sonata				
4 cyl. 2.0L Turbo	VO-148	VA-265	VCA-1075	NS ⁴³⁷
4 cyl. 2.4L	VO-106	VA-265	VCA-1075	NS ⁴³⁷
4 cyl. 2.4L Hybrid	VO-106	VA-265	VCA-1075	NS ⁴³⁷
Tucson				
4 cyl. 2.0L	VO-148	VA-283	VCA-1047	NS ⁴³⁷
4 cyl. 2.4L	VO-106	VA-283	VCA-1047	NS ⁴³⁷
Veloster				
4 cyl. 1.6L	VO-106	VA-300	VCA-1047	NS ⁴³⁷

Se reporter à table de matière pour les notes en bas de page en français. Utilize el contenido para ver notas a pie.

NS - Non-Serviceable / Non réparable / No reparable LF - Life-Time Filter / Filtro para toda la vida / Filtre à vie

⁴³⁷ Requires replacement of the complete fuel pump/fuel filter module.



HYUNDAI (cont'd)

2014

Veloster

4 cyl. 1.6L Turbo	VO-106	VA-300	VCA-1047	NS ⁴³⁷
-------------------	--------	--------	----------	-------------------

2013

Accent

4 cyl. 1.6L	VO-106	VA-300	VCA-1047	NS ⁴³⁷
-------------	--------	--------	----------	-------------------

Azera

V6 3.3L	VO-109	VA-265	VCA-1075	NS ⁴³⁷
---------	--------	--------	----------	-------------------

Elantra

4 cyl. 1.8L	VO-148	VA-334	VCA-1051	NS ⁴³⁷
-------------	--------	--------	----------	-------------------

Equus

V8 5.0L	VO-99	VA-358	VCA-1062	NS ⁴³⁷
---------	-------	--------	----------	-------------------

Genesis

V6 3.8L	VO-99	VA-358	VCA-1062	NS ⁴³⁷
---------	-------	--------	----------	-------------------

V8 5.0L	VO-99	VA-358	VCA-1062	NS ⁴³⁷
---------	-------	--------	----------	-------------------

Genesis Coupe

4 cyl. 2.0L Turbo	VO-148	VA-392	VCA-1047	NS
-------------------	--------	--------	----------	----

V6 3.8L	VO-99	VA-331	VCA-1047	NS ⁴³⁷
---------	-------	--------	----------	-------------------

Santa Fe

V6 3.3L	VO-109	VA-311	VCA-1075	NS ⁴³⁷
---------	--------	--------	----------	-------------------

Santa Fe Sport

4 cyl. 2.0L Turbo	VO-148	VA-311	VCA-1075	NS ⁴³⁷
-------------------	--------	--------	----------	-------------------

4 cyl. 2.4L	VO-106	VA-311	VCA-1075	NS ⁴³⁷
-------------	--------	--------	----------	-------------------

Santa Fe XL

V6 3.3L	VO-109	VA-311	VCA-1075	NS ⁴³⁷
---------	--------	--------	----------	-------------------

Sonata

4 cyl. 2.0L Turbo	VO-148	VA-265	VCA-1075	NS ⁴³⁷
-------------------	--------	--------	----------	-------------------

4 cyl. 2.4L	VO-106	VA-265	VCA-1075	NS ⁴³⁷
-------------	--------	--------	----------	-------------------

4 cyl. 2.4L Hybrid	VO-106	VA-265	VCA-1075	NS ⁴³⁷
--------------------	--------	--------	----------	-------------------

Tucson

4 cyl. 2.0L	VO-148	VA-283	VCA-1047	NS ⁴³⁷
-------------	--------	--------	----------	-------------------

4 cyl. 2.4L	VO-106	VA-283	VCA-1047	NS ⁴³⁷
-------------	--------	--------	----------	-------------------

Veloster

4 cyl. 1.6L	VO-106	VA-300	VCA-1047	NS ⁴³⁷
-------------	--------	--------	----------	-------------------

4 cyl. 1.6L Turbo	VO-106	VA-300	VCA-1047	NS ⁴³⁷
-------------------	--------	--------	----------	-------------------

2012

Accent

4 cyl. 1.6L	VO-106	VA-300	VCA-1047	NS ⁴³⁷
-------------	--------	--------	----------	-------------------

Azera

V6 3.3L	VO-109	VA-265	VCA-1075	NS ⁴³⁷
---------	--------	--------	----------	-------------------

Elantra

4 cyl. 1.8L	VO-106	VA-334	VCA-1051	NS ⁴³⁷
-------------	--------	--------	----------	-------------------

Elantra Touring

4 cyl. 2.0L	VO-106	VA-235		NS ⁴³⁷
-------------	--------	--------	--	-------------------

Equus

V8 5.0L	VO-99	VA-358	VCA-1062	NS ⁴³⁷
---------	-------	--------	----------	-------------------

Genesis

V6 3.8L	VO-99	VA-358	VCA-1062	NS ⁴³⁷
---------	-------	--------	----------	-------------------

V8 4.6L	VO-99	VA-358	VCA-1062	NS ⁴³⁷
---------	-------	--------	----------	-------------------

V8 5.0L	VO-99	VA-358	VCA-1062	NS ⁴³⁷
---------	-------	--------	----------	-------------------

Genesis Coupe

4 cyl. 2.0L Turbo	VO-106	VA-378	VCA-1047	NS ⁴³⁷
-------------------	--------	--------	----------	-------------------

V6 3.8L	VO-99	VA-378	VCA-1047	NS ⁴³⁷
---------	-------	--------	----------	-------------------

Se reporter à table de matière pour les notes en bas de page en français. Utilize el contenido para ver notas a pie.

NS - Non-Serviceable / Non réparable / No reparable LF - Life-Time Filter / Filtro para toda la vida / Filtre à vie

⁴³⁷ Requires replacement of the complete fuel pump/fuel filter module.



HYUNDAI (cont'd)

	Oil	Air	Cabin*	Fuel
2012				
Santa Fe				
4 cyl. 2.4L	VO-106	VA-265	VCA-1072 ^{X877} VCA-1071 ^{Z877}	NS ⁴³⁷
V6 3.5L	VO-109	VA-265	VCA-1072 ^{X877} VCA-1071 ^{Z877}	NS ⁴³⁷
Sonata				
4 cyl. 2.0L Turbo	VO-106	VA-265	VCA-1075	NS ⁴³⁷
4 cyl. 2.4L	VO-106	VA-265	VCA-1075	NS ⁴³⁷
4 cyl. 2.4L Hybrid	VO-106	VA-265	VCA-1075	NS ⁴³⁷
Tucson				
4 cyl. 2.0L	VO-106	VA-283	VCA-1047	NS ⁴³⁷
4 cyl. 2.4L	VO-106	VA-283	VCA-1047	NS ⁴³⁷
Veloster				
4 cyl. 1.6L	VO-106	VA-300	VCA-1047	NS ⁴³⁷
Veracruz				
V6 3.8L	VO-99	VA-372	VCA-1144	NS ⁴³⁷
2011				
Accent				
4 cyl. 1.6L FI	VO-106	VA-201	VCA-1051	NS ⁴³⁷
Azera				
V6 3.3L	VO-99	VA-227	VCA-1072	NS ⁴³⁷
V6 3.8L	VO-99	VA-227	VCA-1072	NS ⁴³⁷
Elantra				
4 cyl. 1.8L	VO-106	VA-334	VCA-1051	NS ⁴³⁷
Elantra Touring				
4 cyl. 2.0L	VO-106	VA-235		NS ⁴³⁷
Equus				
V8 4.6L	VO-99	VA-358	VCA-1062	NS ⁴³⁷
Genesis				
V6 3.8L	VO-99	VA-383	VCA-1062	NS ⁴³⁷
V8 4.6L	VO-99	VA-358	VCA-1062	NS ⁴³⁷
Genesis Coupe				
4 cyl. 2.0L FI Turbo	VO-106	VA-378	VCA-1047	NS ⁴³⁷
V6 3.8L	VO-99	VA-378	VCA-1047	NS ⁴³⁷
Santa Fe				
4 cyl. 2.4L FI	VO-106	VA-265	VCA-1072 ^{X877} VCA-1071 ^{Z877}	NS ⁴³⁷
V6 3.5L	VO-109	VA-265	VCA-1072 ^{X877} VCA-1071 ^{Z877}	NS ⁴³⁷
Sonata				
4 cyl. 2.0L Turbo	VO-106	VA-265	VCA-1075	NS ⁴³⁷
4 cyl. 2.4L	VO-106	VA-265	VCA-1075	NS ⁴³⁷
4 cyl. 2.4L (Hybrid)	VO-106	VA-265	VCA-1075	NS ⁴³⁷
Tucson				
4 cyl. 2.0L	VO-106	VA-283	VCA-1047	NS ⁴³⁷
4 cyl. 2.4L	VO-106	VA-283	VCA-1047	NS ⁴³⁷
Veracruz				
V6 3.8L	VO-99	VA-372	VCA-1144	NS ⁴³⁷
2010				
Accent				
4 cyl. 1.6L FI	VO-106	VA-201	VCA-1051	NS ⁴³⁷

Se reporter à table de matière pour les notes en bas de page en français. Utilize el contenido para ver notas a pie.

NS - Non-Serviceable / Non réparable / No reparable LF - Life-Time Filter / Filtro para toda la vida / Filtre à vie

⁴³⁷ Requires replacement of the complete fuel pump/fuel filter module. ^{X877}8.98 inch wide filter ^{Z877}with 8.2 inch wide filter



HYUNDAI (cont'd)

2010

Azera

V6 3.3L	VO-99	VA-227	VCA-1072	NS ⁴³⁷
V6 3.8L	VO-99	VA-227	VCA-1072	NS ⁴³⁷

Elantra

4 cyl. 2.0L	VO-106	VA-235	VCA-1051	NS ⁴³⁷
-------------	--------	--------	----------	-------------------

Elantra Touring

4 cyl. 2.0L	VO-106	VA-235		NS ⁴³⁷
-------------	--------	--------	--	-------------------

Entourage

V6 3.8L FI	VO-99	VA-230	VCA-1066	NS ⁴³⁷
------------	-------	--------	----------	-------------------

Genesis

V6 3.8L	VO-99	VA-383	VCA-1062	NS ⁴³⁷
V8 4.6L	VO-99	VA-358	VCA-1062	NS ⁴³⁷

Genesis Coupe

4 cyl. 2.0L Turbo	VO-106	VA-378	VCA-1047	NS ⁴³⁷
V6 3.8L	VO-99	VA-378	VCA-1047	NS ⁴³⁷

Santa Fe

4 cyl. 2.4L	VO-106	VA-265	VCA-1071	NS ⁴³⁷
V6 3.5L FI	VO-109	VA-265	VCA-1071	NS ⁴³⁷

Sonata

4 cyl 2.4L	VO-106	VA-228	VCA-1072	NS ⁴³⁷
V6 3.3L	VO-90 ^{X427} VO-99 ^{Z427}	VA-227	VCA-1072	NS ⁴³⁷

Tucson

4 cyl 2.4L	VO-106	VA-283	VCA-1047	NS ⁴³⁷
------------	--------	--------	----------	-------------------

Veracruz

V6 3.8L	VO-99	VA-372	VCA-1144	NS ⁴³⁷
---------	-------	--------	----------	-------------------

2009

Accent

4 cyl. 1.6L FI	VO-106	VA-201	VCA-1051	NS ⁴³⁷
----------------	--------	--------	----------	-------------------

Azera

V6 3.3L FI	VO-90	VA-227	VCA-1035 ^{X711} VCA-1072 ^{Z711}	NS ⁴³⁷
V6 3.8L FI	VO-90 ^{X427} VO-99 ^{Z427}	VA-227	VCA-1035 ^{X711} VCA-1072 ^{Z711}	NS ⁴³⁷

Elantra

4 cyl. 2.0L FI	VO-106	VA-235	VCA-1051	NS ⁴³⁷
----------------	--------	--------	----------	-------------------

Entourage

V6 3.8L FI	VO-99	VA-230	VCA-1066	NS ⁴³⁷
------------	-------	--------	----------	-------------------

Genesis

V6 3.8L	VO-99	VA-383	VCA-1062	NS ⁴³⁷
V8 4.6L	VO-99	VA-358	VCA-1062	NS ⁴³⁷

Santa Fe

V6 2.7L FI	VO-106	VA-240	VCA-1035	NS ⁴³⁷
V6 3.3L FI	VO-90 ^{X427} VO-99 ^{Z427}	VA-240	VCA-1035	NS ⁴³⁷

Sonata

4 cyl 2.4L FI	VO-106	VA-228	VCA-1072	NS ⁴³⁷
V6 3.3L FI	VO-90 ^{X427} VO-99 ^{Z427}	VA-227	VCA-1072	NS ⁴³⁷

Se reporter à table de matière pour les notes en bas de page en français. Utilize el contenido para ver notas a pie.

NS - Non-Serviceable / Non réparable / No reparable LF - Life-Time Filter / Filtro para toda la vida / Filtre à vie

⁴³⁷ Requires replacement of the complete fuel pump/fuel filter module. ^{X427}With filter height 5.1 inch. ^{X711}With Auto Temperature Control. ^{Z427}With filter height 4.2 inch. ^{Z711}Without Auto Temperature Control.



HYUNDAI (cont'd)

2009				
Tucson				
4 cyl. 2.0L FI	VO-106	VA-208	VCA-1047 ^{X497} VCA-1057 ^{Z497}	NS ⁴³⁷
V6 2.7L FI	VO-106	VA-208	VCA-1047 ^{X497} VCA-1057 ^{Z497}	NS ⁴³⁷
Veracruz				
V6 3.8L FI	VO-90 ^{X427} VO-99 ^{Z427}	VA-372	VCA-1144	NS ⁴³⁷
2008				
Accent				
4 cyl. 1.6L FI	VO-106	VA-201	VCA-1138 ^{X338} VCA-1051 ^{Z338}	NS ⁴³⁷
Azera				
V6 3.3L FI	VO-90	VA-227	VCA-1035	NS ⁴³⁷
V6 3.8L FI	VO-90	VA-227	VCA-1035	NS ⁴³⁷
Elantra				
4 cyl. 2.0L FI	VO-106	VA-235	VCA-1051	NS ⁴³⁷
Entourage				
V6 3.8L FI	VO-90	VA-230	VCA-1066	NS ⁴³⁷
Santa Fe				
V6 2.7L FI	VO-106	VA-240	VCA-1035	NS ⁴³⁷
V6 3.3L FI	VO-90	VA-240	VCA-1035	NS ⁴³⁷
Sonata				
4 cyl. 2.4L FI	VO-106	VA-228	VCA-1035 ^{X711} VCA-1072 ^{Z711}	NS ⁴³⁷
V6 3.3L FI	VO-90	VA-227	VCA-1035 ^{X711} VCA-1072 ^{Z711}	NS ⁴³⁷
Tiburon				
4 cyl. 2.0L FI	VO-106	VA-193	VCA-1066	NS ⁴³⁷
V6 2.7L FI	VO-106	VA-193	VCA-1066	NS ⁴³⁷
Tucson				
4 cyl. 2.0L FI	VO-106	VA-208	VCA-1047 ^{X497} VCA-1057 ^{Z497}	NS ⁴³⁷
V6 2.7L FI	VO-106	VA-208	VCA-1047 ^{X497} VCA-1057 ^{Z497}	NS ⁴³⁷
Veracruz				
V6 3.8L FI	VO-90 ^{X427} VO-99 ^{Z427}	VA-372	VCA-1144	NS ⁴³⁷
2007				
Accent				
4 cyl. 1.6L FI	VO-106	VA-201	VCA-1138	NS ⁴³⁷
Azera				
V6 3.3L FI	VO-90	VA-227	VCA-1035	NS ⁴³⁷
V6 3.8L FI	VO-90	VA-227	VCA-1035	NS ⁴³⁷
Elantra				
4 cyl. 2.0L FI	VO-106	VA-235	VCA-1051	NS ⁴³⁷
Entourage				
V6 3.8L FI	VO-90	VA-230	VCA-1066	NS ⁴³⁷
Santa Fe				
V6 2.7L FI	VO-106	VA-240	VCA-1035	NS ⁴³⁷
V6 3.3L FI	VO-90	VA-240	VCA-1035	NS ⁴³⁷

Se reporter à table de matière pour les notes en bas de page en français. Utilize el contenido para ver notas a pie.

NS - Non-Serviceable / Non réparable / No reparable LF - Life-Time Filter / Filtro para toda la vida / Filtre à vie

⁴³⁷ Requires replacement of the complete fuel pump/fuel filter module. ^{X338} Before 5/10/07. ^{X427} With filter height 5.1 inch. ^{X497} DCC HVAC systems.

^{X711} With Auto Temperature Control. ^{Z338} After 5/10/07. ^{Z427} With filter height 4.2 inch. ^{Z497} HCC HVAC systems. ^{Z711} Without Auto Temperature Control.



HYUNDAI (cont'd)

2007

Sonata

4 cyl. 2.4L FI	VO-106	VA-228	VCA-1035 ^{X711} VCA-1072 ^{Z711}	NS ⁴³⁷
V6 3.3L FI	VO-90	VA-227	VCA-1035 ^{X711} VCA-1072 ^{Z711}	NS ⁴³⁷

Tiburon

4 cyl. 2.0L FI	VO-106	VA-193	VCA-1066	NS ⁴³⁷
V6 2.7L FI	VO-106	VA-193	VCA-1066	NS ⁴³⁷

Tucson

4 cyl. 2.0L FI	VO-106	VA-208	VCA-1047 ^{X497} VCA-1057 ^{Z497}	NS ⁴³⁷
V6 2.7L FI	VO-106	VA-208	VCA-1047 ^{X497} VCA-1057 ^{Z497}	NS ⁴³⁷

Veracruz

V6 3.8L FI	VO-90 ^{X427} VO-99 ^{Z427}	VA-372	VCA-1144	NS ⁴³⁷
------------	--	--------	----------	-------------------

2006

Accent

4 cyl. 1.6L FI	VO-106	VA-201	VCA-1138	NS ⁴³⁷
----------------	--------	--------	----------	-------------------

Azera

V6 3.8L FI	VO-90	VA-227	VCA-1035	NS ⁴³⁷
------------	-------	--------	----------	-------------------

Elantra

4 cyl. 2.0L FI	VO-106	VA-193	VCA-1066	NS ⁴³⁷
----------------	--------	--------	----------	-------------------

Santa Fe

4 cyl. 2.4L FI (Canada)	VO-106	VA-172	VCA-1139	NS ⁴³⁷
V6 2.7L FI	VO-106	VA-172	VCA-1139	NS ⁴³⁷
V6 3.5L FI	VO-106	VA-359	VCA-1139	NS ⁴³⁷

Sonata

4 cyl. 2.4L FI	VO-106	VA-228	VCA-1035 ^{X711} VCA-1072 ^{Z711}	NS ⁴³⁷
V6 3.3L FI	VO-90	VA-227	VCA-1035 ^{X711} VCA-1072 ^{Z711}	NS ⁴³⁷

Tiburon

4 cyl. 2.0L FI	VO-106	VA-193	VCA-1066	NS ⁴³⁷
V6 2.7L FI	VO-106	VA-193	VCA-1066	NS ⁴³⁷

Tucson

4 cyl. 2.0L FI	VO-106	VA-208	VCA-1047 ^{X497} VCA-1057 ^{Z497}	NS ⁴³⁷
V6 2.7L FI	VO-106	VA-208	VCA-1047 ^{X497} VCA-1057 ^{Z497}	NS ⁴³⁷

2005

Accent

4 cyl. 1.6L FI	VO-106	VA-166	VCA-1054	
----------------	--------	--------	----------	--

Elantra

4 cyl. 2.0L FI	VO-106	VA-193	VCA-1066	NS ⁴³⁷
----------------	--------	--------	----------	-------------------

Santa Fe

4 cyl. 2.4L FI (Canada)	VO-106	VA-172	VCA-1139	NS ⁴³⁷
V6 2.7L FI	VO-106	VA-172	VCA-1139	NS ⁴³⁷
V6 3.5L FI	VO-106	VA-359	VCA-1139	NS ⁴³⁷

Sonata

4 cyl. 2.4L FI	VO-106	VA-152	VCA-1139	NS ⁴³⁷
V6 2.7L FI	VO-106	VA-152	VCA-1139	NS ⁴³⁷

Se reporter à table de matière pour les notes en bas de page en français. Utilize el contenido para ver notas a pie.

NS - Non-Serviceable / Non réparable / No reparable LF - Life-Time Filter / Filtro para toda la vida / Filtre à vie

⁴³⁷ Requires replacement of the complete fuel pump/fuel filter module. ^{X427A}With filter height 5.1 inch. ^{X497}DCC HVAC systems. ^{X711}With Auto Temperature Control. ^{Z427}With filter height 4.2 inch. ^{Z497}HCC HVAC systems. ^{Z711}Without Auto Temperature Control.



HYUNDAI (cont'd)

	Oil	Air	Cabin*	Fuel
2005				
Tiburon				
4 cyl. 2.0L FI	VO-106	VA-193	VCA-1066	NS ⁴³⁷
V6 2.7L FI	VO-106	VA-193	VCA-1066	NS ⁴³⁷
Tucson				
4 cyl. 2.0L FI	VO-106	VA-208	VCA-1047	NS ⁴³⁷
V6 2.7L FI	VO-106	VA-208	VCA-1047	NS ⁴³⁷
XG350				
V6 3.5L FI	VO-106	VA-345	VCA-1139	NS ⁴³⁷
2004				
Accent				
4 cyl. 1.6L FI	VO-106	VA-166	VCA-1054	
Elantra				
4 cyl. 2.0L FI	VO-106	VA-193	VCA-1066	NS ⁴³⁷
Santa Fe				
4 cyl. 2.4L FI	VO-106	VA-172	VCA-1139	NS ⁴³⁷
V6 2.7L FI	VO-106	VA-172	VCA-1139	NS ⁴³⁷
V6 3.5L FI	VO-106	VA-359	VCA-1139	NS ⁴³⁷
Sonata				
4 cyl. 2.4L FI	VO-106	VA-152	VCA-1139	NS ⁴³⁷
V6 2.7L FI	VO-106	VA-152	VCA-1139	NS ⁴³⁷
Tiburon				
4 cyl. 2.0L FI	VO-106	VA-193	VCA-1066	NS ⁴³⁷
V6 2.7L FI	VO-106	VA-193	VCA-1066	NS ⁴³⁷
XG350				
V6 3.5L FI	VO-106	VA-345	VCA-1139	NS ⁴³⁷
2003				
Accent				
4 cyl. 1.5L FI	VO-106	VA-166	VCA-1054	
4 cyl. 1.6L FI	VO-106	VA-166	VCA-1054	
Elantra				
4 cyl. 2.0L FI	VO-106	VA-193	VCA-1066	NS ⁴³⁷
Santa Fe				
4 cyl. 2.4L FI	VO-106	VA-172	VCA-1139	NS ⁴³⁷
V6 2.7L FI	VO-106	VA-172	VCA-1139	NS ⁴³⁷
V6 3.5L FI	VO-106	VA-359	VCA-1139	NS ⁴³⁷
Sonata				
4 cyl. 2.4L FI	VO-106	VA-152	VCA-1139	NS ⁴³⁷
V6 2.7L FI	VO-106	VA-152	VCA-1139	NS ⁴³⁷
Tiburon				
4 cyl. 2.0L FI	VO-106	VA-193	VCA-1066	NS ⁴³⁷
V6 2.7L FI	VO-106	VA-193	VCA-1066	NS ⁴³⁷
XG350				
V6 3.5L FI	VO-106	VA-345	VCA-1139	NS ⁴³⁷
2002				
Accent				
4 cyl. 1.5L FI	VO-106	VA-166		
4 cyl. 1.6L FI	VO-106	VA-166 ³⁶⁴		
Elantra				
4 cyl. 2.0L FI	VO-106	VA-193	VCA-1066	NS ⁴³⁷
Santa Fe				
4 cyl. 2.4L FI	VO-106	VA-172	VCA-1139	NS ⁴³⁷
V6 2.7L FI	VO-106	VA-172	VCA-1139	NS ⁴³⁷

Se reporter à table de matière pour les notes en bas de page en français. Utilize el contenido para ver notas a pie.

NS - Non-Serviceable / Non réparable / No repairable LF - Life-Time Filter / Filtro para toda la vida / Filtre à vie

³⁶⁴ 9.75 inch length. ⁴³⁷ Requires replacement of the complete fuel pump/fuel filter module.



HYUNDAI (cont'd)

2002

Sonata

4 cyl. 2.4L FI	VO-106	VA-152	VCA-1139	NS ⁴³⁷
V6 2.7L FI	VO-106	VA-152	VCA-1139	NS ⁴³⁷

XG350

V6 3.5L FI	VO-106	VA-345	VCA-1139	NS ⁴³⁷
------------	--------	--------	----------	-------------------

2001

Accent

4 cyl. 1.5L FI	VO-106	VA-166		
4 cyl. 1.6L FI	VO-106	VA-166 ³⁶⁴		

Elantra

4 cyl. 2.0L FI	VO-106	VA-193	VCA-1066	NS ⁴³⁷
----------------	--------	--------	----------	-------------------

Santa Fe

4 cyl. 2.4L FI	VO-106	VA-172	VCA-1139	NS ⁴³⁷
V6 2.7L FI	VO-106	VA-172	VCA-1139	NS ⁴³⁷

Sonata

4 cyl. 2.4L FI	VO-106	VA-152	VCA-1139	
V6 2.5L FI	VO-106	VA-152	VCA-1139	

Tiburon

4 cyl. 2.0L FI	VO-106	VA-131		
----------------	--------	--------	--	--

XG300

V6 3.0L FI	VO-106	VA-345	VCA-1139	
------------	--------	--------	----------	--

2000

Accent

4 cyl. 1.5L FI	VO-106	VA-166		
----------------	--------	--------	--	--

Elantra

4 cyl. 2.0L FI	VO-106	VA-131		
----------------	--------	--------	--	--

Sonata

4 cyl. 2.4L FI	VO-106	VA-152	VCA-1139	
V6 2.5L FI	VO-106	VA-152	VCA-1139	

Tiburon

4 cyl. 2.0L FI	VO-106	VA-131		
----------------	--------	--------	--	--

1999

Accent

4 cyl. 1.5L FI	VO-106			
----------------	--------	--	--	--

Elantra

4 cyl. 2.0L FI	VO-106	VA-131		
----------------	--------	--------	--	--

Sonata

4 cyl. 2.4L FI	VO-106	VA-152	VCA-1139	
V6 2.5L FI	VO-106	VA-152	VCA-1139	

Tiburon

4 cyl. 2.0L FI	VO-106	VA-131		
----------------	--------	--------	--	--

1998

Accent

4 cyl. 1.5L FI	VO-106			
----------------	--------	--	--	--

Elantra

4 cyl. 1.8L FI	VO-106	VA-131		
----------------	--------	--------	--	--

Sonata

4 cyl. 2.0L FI	VO-106			
V6 3.0L FI	VO-106			

Tiburon

4 cyl. 2.0L FI	VO-106	VA-131		
----------------	--------	--------	--	--

Se reporter à table de matière pour les notes en bas de page en français. Utilize el contenido para ver notas a pie.

NS - Non-Serviceable / Non réparable / No reparable LF - Life-Time Filter / Filtro para toda la vida / Filtre à vie

³⁶⁴ 9.75 inch length. ⁴³⁷ Requires replacement of the complete fuel pump/fuel filter module.



HYUNDAI (cont'd)

1997				
Accent				
4 cyl. 1.5L FI	VO-106			
Elantra				
4 cyl. 1.8L FI	VO-106	VA-131		
Sonata				
4 cyl. 2.0L FI	VO-106			
V6 3.0L FI	VO-106			
Tiburon				
4 cyl. 1.8L FI	VO-106	VA-131		
4 cyl. 2.0L FI	VO-106	VA-131		
1996				
Accent				
4 cyl. 1.5L FI	VO-106			
Elantra				
4 cyl. 1.8L FI	VO-106	VA-131		
Sonata				
4 cyl. 2.0L FI	VO-106			
V6 3.0L FI	VO-106			
1995				
Accent				
4 cyl. 1.5L FI	VO-106			
Elantra				
4 cyl. 1.6L FI	VO-106			
4 cyl. 1.8L FI	VO-106			
Scoupe				
4 cyl. 1.5L FI Non Turbo	VO-106			
4 cyl. 1.5L FI Turbo	VO-106			
Sonata				
4 cyl. 2.0L FI	VO-106			
V6 3.0L FI	VO-106			

INFINITI

2019				
Q50				
4 cyl. 2.0L Turbo	VO-164		VCA-1044	NS ⁴³⁷
V6 3.0L Turbo	VO-106	VA-261 ¹¹²	VCA-1044	NS ⁴³⁷
V6 3.5 Hybrid	VO-106	VA-244 ¹¹²	VCA-1044	NS ⁴³⁷
Q60				
4 cyl. 2.0L Turbo	VO-164		VCA-1044	NS ⁴³⁷
V6 3.0L Turbo	VO-106	VA-261 ¹¹²	VCA-1044	NS ⁴³⁷
Q70				
V6 3.7L	VO-106	VA-391 ¹¹²		NS ⁴³⁷
V8 5.6L	VO-106	VA-261 ¹¹²		NS ⁴³⁷
QX30				
4 cyl. 2.0 Turbo	VO-164	VA-449		NS ⁴³⁷
QX50				
4 cyl. 2.0L Turbo	VO-106			NS ⁴³⁷
QX60				
V6 3.5L	VO-106	VA-86	VCA-1082	NS ⁴³⁷
QX80				
V8 5.6	VO-106		VCA-1044	NS ⁴³⁷

Se reporter à table de matière pour les notes en bas de page en français. Utilize el contenido para ver notas a pie.

NS - Non-Serviceable / Non réparable / No reparable LF - Life-Time Filter / Filtro para toda la vida / Filtre à vie

¹¹² Requires two (2). ⁴³⁷ Requires replacement of the complete fuel pump/fuel filter module.



INFINITI (cont'd)

2018

Q50

4 cyl. 2.0L Turbo	VO-164		VCA-1044	NS ⁴³⁷
V6 3.0L Turbo	VO-106	VA-261 ¹¹²	VCA-1044	NS ⁴³⁷
V6 3.5 Hybrid	VO-106	VA-244 ¹¹²	VCA-1044	NS ⁴³⁷

Q60

4 cyl. 2.0L Turbo	VO-164		VCA-1044	NS ⁴³⁷
V6 3.0L Turbo	VO-106	VA-261 ¹¹²	VCA-1044	NS ⁴³⁷

Q70

V6 3.5L Hybrid	VO-106			NS ⁴³⁷
V6 3.7L	VO-106	VA-391 ¹¹²		NS ⁴³⁷
V8 5.6L	VO-106	VA-261 ¹¹²		NS ⁴³⁷

QX30

4 cyl. 2.0 Turbo	VO-164	VA-449		NS ⁴³⁷
------------------	--------	--------	--	-------------------

QX60

V6 3.5L	VO-106	VA-86	VCA-1082	NS ⁴³⁷
---------	--------	-------	----------	-------------------

QX80

V8 5.6	VO-106		VCA-1044	NS ⁴³⁷
--------	--------	--	----------	-------------------

2017

Q50

4 cyl. 2.0L Turbo	VO-164		VCA-1044	NS ⁴³⁷
V6 3.0L Turbo	VO-106	VA-261 ¹¹²	VCA-1044	NS ⁴³⁷
V6 3.5 Hybrid	VO-106	VA-244 ¹¹²	VCA-1044	NS ⁴³⁷

Q60

4 cyl. 2.0L Turbo	VO-164		VCA-1044	NS ⁴³⁷
V6 3.0L Turbo	VO-106	VA-261 ¹¹²	VCA-1044	NS ⁴³⁷

Q70

V6 3.5L Hybrid	VO-106			NS ⁴³⁷
V6 3.7L	VO-106	VA-391 ¹¹²		NS ⁴³⁷
V8 5.6L	VO-106	VA-261 ¹¹²		NS ⁴³⁷

QX30

4 cyl. 2.0 Turbo	VO-164	VA-449		NS ⁴³⁷
------------------	--------	--------	--	-------------------

QX50

V6 3.7L	VO-106	VA-332 ¹¹²	VCA-1044	NS ⁴³⁷
---------	--------	-----------------------	----------	-------------------

QX60

4 cyl. 2.5L Supercharged	VO-106		VCA-1082	NS ⁴³⁷
V6 3.5L	VO-106	VA-86	VCA-1082	NS ⁴³⁷

QX70

V6 3.7L	VO-106	VA-261	VCA-1044	NS ⁴³⁷
---------	--------	--------	----------	-------------------

QX80

V8 5.6	VO-106		VCA-1044	NS ⁴³⁷
--------	--------	--	----------	-------------------

2016

Q50

4 cyl. 2.0L Turbo	VO-164		VCA-1044	NS ⁴³⁷
V6 3.0L Turbo	VO-106	VA-261 ¹¹²	VCA-1044	NS ⁴³⁷
V6 3.5 (Hybrid)	VO-106	VA-244 ¹¹²	VCA-1044	NS ⁴³⁷

Q70

V6 3.5L Hybrid	VO-106			NS ⁴³⁷
V6 3.7L	VO-106	VA-391 ¹¹²		NS ⁴³⁷
V8 5.6L	VO-106	VA-261 ¹¹²		NS ⁴³⁷

QX50

V6 3.7L	VO-106	VA-332 ¹¹²	VCA-1044	NS ⁴³⁷
---------	--------	-----------------------	----------	-------------------

Se reporter à table de matière pour les notes en bas de page en français. Utilize el contenido para ver notas a pie.

NS - Non-Serviceable / Non réparable / No reparable LF - Life-Time Filter / Filtro para toda la vida / Filtre à vie

¹¹² Requires two (2). ⁴³⁷ Requires replacement of the complete fuel pump/fuel filter module.



INFINITI (cont'd)

	Oil	Air	Cabin*	Fuel
2016				
QX60				
4 cyl. 2.5L Supercharged	VO-106		VCA-1082	NS ⁴³⁷
V6 3.5L	VO-106	VA-86	VCA-1082	NS ⁴³⁷
QX70				
V6 3.7L	VO-106	VA-261	VCA-1044	NS ⁴³⁷
QX80				
V8 5.6	VO-106		VCA-1044	NS ⁴³⁷
2015				
Q40				
V6 3.7L FI	VO-106	VA-332 ¹¹²	VCA-1044	
Q50				
V6 3.5 Hybrid	VO-106	VA-244 ¹¹²	VCA-1044	NS ⁴³⁷
V6 3.7L	VO-106	VA-244 ¹¹²	VCA-1044	NS ⁴³⁷
Q60				
V6 3.7	VO-106	VA-332 ¹¹²	VCA-1044	NS ⁴³⁷
Q70				
V6 3.5L Hybrid	VO-106			NS ⁴³⁷
V6 3.7L	VO-106	VA-391 ¹¹²		NS ⁴³⁷
V8 5.6L	VO-106	VA-261 ¹¹²		NS ⁴³⁷
QX50				
V6 3.7L	VO-106	VA-332 ¹¹²	VCA-1044	NS ⁴³⁷
QX60				
4 cyl. 2.5L FI (S.C)	VO-106		VCA-1082	NS ⁴³⁷
V6 3.5L	VO-106	VA-86	VCA-1082	NS ⁴³⁷
QX70				
V6 3.7L	VO-106	VA-261	VCA-1044	NS ⁴³⁷
QX80				
V8 5.6	VO-106		VCA-1044	NS ⁴³⁷
2014				
Q50				
V6 3.5 Hybrid	VO-106	VA-244 ¹¹²	VCA-1044	NS ⁴³⁷
V6 3.7L	VO-106	VA-244 ¹¹²	VCA-1044	NS ⁴³⁷
Q60				
V6 3.7	VO-106	VA-332 ¹¹²	VCA-1044	NS ⁴³⁷
Q70				
V6 3.5L Hybrid	VO-106			NS ⁴³⁷
V6 3.7L	VO-106	VA-391 ¹¹²		NS ⁴³⁷
V8 5.6L	VO-106	VA-261 ¹¹²		NS ⁴³⁷
QX50				
V6 3.7L	VO-106	VA-332 ¹¹²	VCA-1044	NS ⁴³⁷
QX60				
4 cyl. 2.5L FI (S.C)	VO-106		VCA-1082	NS ⁴³⁷
V6 3.5L	VO-106	VA-86	VCA-1082	NS ⁴³⁷
QX70				
V6 3.7L	VO-106	VA-261	VCA-1044	NS ⁴³⁷
V8 5.0L	VO-106	VA-261 ¹¹²	VCA-1044	NS ⁴³⁷
QX80				
V8 5.6	VO-106		VCA-1044	NS ⁴³⁷
2013				
EX37				
V6 3.7L FI	VO-106	VA-332	VCA-1044	NS ⁴³⁷

Se reporter à table de matière pour les notes en bas de page en français. Utilize el contenido para ver notas a pie.

NS - Non-Serviceable / Non réparable / No repairable LF - Life-Time Filter / Filtro para toda la vida / Filtre à vie

¹¹² Requires two (2). ⁴³⁷ Requires replacement of the complete fuel pump/fuel filter module.



INFINITI (cont'd)

2013

FX37

V6 3.7L FI	VO-106	VA-261	VCA-1044	NS ⁴³⁷
------------	--------	--------	----------	-------------------

FX50

V8 5.0L FI	VO-106	VA-261 ¹¹²	VCA-1044	NS ⁴³⁷
------------	--------	-----------------------	----------	-------------------

G37

V6 3.7L FI	VO-106	VA-332 ¹¹²	VCA-1044	NS ⁴³⁷
------------	--------	-----------------------	----------	-------------------

JX35

V6 3.5L FI	VO-106	VA-86	VCA-1082	NS ⁴³⁷
------------	--------	-------	----------	-------------------

M35 (Hybrid)

V6 3.5L FI (Hybrid)	VO-106			NS ⁴³⁷
---------------------	--------	--	--	-------------------

M37

V6 3.7L FI	VO-106	VA-391 ¹¹²		NS ⁴³⁷
------------	--------	-----------------------	--	-------------------

M56

V8 5.6L	VO-106	VA-261 ¹¹²		NS ⁴³⁷
---------	--------	-----------------------	--	-------------------

QX56

V8 5.6L FI	VO-106		VCA-1044	NS ⁴³⁷
------------	--------	--	----------	-------------------

2012

EX35

V6 3.5L FI	VO-106	VA-332 ¹¹²	VCA-1044	NS ⁴³⁷
------------	--------	-----------------------	----------	-------------------

FX35

V6 3.5L FI	VO-106	VA-261 ¹¹²	VCA-1044	NS ⁴³⁷
------------	--------	-----------------------	----------	-------------------

FX50

V8 5.0L FI	VO-106	VA-261 ¹¹²	VCA-1044	NS ⁴³⁷
------------	--------	-----------------------	----------	-------------------

G25

V6 2.5L FI	VO-106	VA-332	VCA-1044	NS ⁴³⁷
------------	--------	--------	----------	-------------------

G37

V6 3.7L FI	VO-106	VA-332 ¹¹²	VCA-1044	NS ⁴³⁷
------------	--------	-----------------------	----------	-------------------

M35 (Hybrid)

V6 3.5L FI (Hybrid)	VO-106			NS ⁴³⁷
---------------------	--------	--	--	-------------------

M37

V6 3.7L FI	VO-106	VA-391 ¹¹²		NS ⁴³⁷
------------	--------	-----------------------	--	-------------------

M56

V8 5.6L	VO-106	VA-261 ¹¹²		NS ⁴³⁷
---------	--------	-----------------------	--	-------------------

QX56

V8 5.6L FI	VO-106		VCA-1044	NS ⁴³⁷
------------	--------	--	----------	-------------------

2011

EX35

V6 3.5L FI	VO-106	VA-332 ¹¹²	VCA-1044	NS ⁴³⁷
------------	--------	-----------------------	----------	-------------------

FX35

V6 3.5L FI	VO-106	VA-261 ¹¹²	VCA-1044	NS ⁴³⁷
------------	--------	-----------------------	----------	-------------------

FX50

V8 5.0L FI	VO-106	VA-261 ¹¹²	VCA-1044	NS ⁴³⁷
------------	--------	-----------------------	----------	-------------------

G25

V6 2.5L FI	VO-106	VA-332	VCA-1044	NS ⁴³⁷
------------	--------	--------	----------	-------------------

G37

V6 3.7L FI	VO-106	VA-332 ¹¹²	VCA-1044	NS ⁴³⁷
------------	--------	-----------------------	----------	-------------------

M37

V6 3.7L FI	VO-106	VA-391 ¹¹²		NS ⁴³⁷
------------	--------	-----------------------	--	-------------------

M56

V8 5.6L	VO-106	VA-261 ¹¹²		NS ⁴³⁷
---------	--------	-----------------------	--	-------------------

Se reporter à table de matière pour les notes en bas de page en français. Utilize el contenido para ver notas a pie.

NS - Non-Serviceable / Non réparable / No reparable LF - Life-Time Filter / Filtro para toda la vida / Filtre à vie

¹¹² Requires two (2). ⁴³⁷ Requires replacement of the complete fuel pump/fuel filter module.



INFINITI (cont'd)

Year	Model	Oil	Air	Cabin*	Fuel
2011					
QX56					
V8 5.6L FI		VO-106		VCA-1044	NS ⁴³⁷
2010					
EX35					
V6 3.5L FI		VO-106	VA-332 ¹¹²	VCA-1044	NS ⁴³⁷
FX35					
V6 3.5L FI		VO-106	VA-261 ¹¹²	VCA-1044	NS ⁴³⁷
FX50					
V8 5.0L FI		VO-106	VA-261 ¹¹²	VCA-1044	NS ⁴³⁷
G37					
V6 3.7L FI		VO-106	VA-332 ¹¹²	VCA-1044	NS ⁴³⁷
M35					
V6 3.5L FI		VO-106	VA-391 ¹¹²	VCA-1044	NS ⁴³⁷
M45					
V8 4.5L FI		VO-106		VCA-1044	NS ⁴³⁷
QX56					
V8 5.6L FI		VO-106	VA-105	VCA-1048	NS ⁴³⁷
2009					
EX35					
V6 3.5L FI		VO-106	VA-332 ¹¹²	VCA-1044	NS ⁴³⁷
FX35					
V6 3.5L FI		VO-106	VA-261 ¹¹²	VCA-1044	NS ⁴³⁷
FX50					
V8 5.0L FI		VO-106	VA-261 ¹¹²	VCA-1044	NS ⁴³⁷
G37					
V6 3.7L FI		VO-106	VA-332 ¹¹²	VCA-1044	NS ⁴³⁷
M35					
V6 3.5L FI		VO-106	VA-391 ¹¹²	VCA-1044	NS ⁴³⁷
M45					
V8 4.5L FI		VO-106		VCA-1044	NS ⁴³⁷
QX56					
V8 5.6L FI		VO-106	VA-105	VCA-1048	NS ⁴³⁷
2008					
EX35					
V6 3.5L FI		VO-106	VA-332 ¹¹²	VCA-1044	NS ⁴³⁷
FX35					
V6 3.5L FI		VO-106	VA-86	VCA-1068	NS ⁴³⁷
FX45					
V8 4.5L FI		VO-106	VA-370	VCA-1068	NS ⁴³⁷
G35					
V6 3.5L FI		VO-106	VA-332 ¹¹²	VCA-1068	NS ⁴³⁷
G37					
V6 3.7L FI		VO-106	VA-332 ¹¹²	VCA-1044	NS ⁴³⁷
M35					
V6 3.5L FI		VO-106	VA-282	VCA-1044	NS ⁴³⁷
M45					
V8 4.5L FI		VO-106		VCA-1044	NS ⁴³⁷
QX56					
V8 5.6L FI		VO-106	VA-105	VCA-1048	NS ⁴³⁷

Se reporter à table de matière pour les notes en bas de page en français. Utilize el contenido para ver notas a pie.

NS - Non-Serviceable / Non réparable / No repairable LF - Life-Time Filter / Filtro para toda la vida / Filtre à vie

¹¹² Requires two (2). ⁴³⁷ Requires replacement of the complete fuel pump/fuel filter module.



INFINITI (cont'd)

2007

FX35

V6 3.5L FI	VO-106	VA-86	VCA-1068	NS ⁴³⁷
------------	--------	-------	----------	-------------------

FX45

V8 4.5L FI	VO-106	VA-370	VCA-1068	NS ⁴³⁷
------------	--------	--------	----------	-------------------

G35

V6 3.5L FI	VO-106	VA-332 ^{X048} VA-86 ^{Z048}	VCA-1068	NS ⁴³⁷
------------	--------	---	----------	-------------------

M35

V6 3.5L FI	VO-106	VA-282	VCA-1044	NS ⁴³⁷
------------	--------	--------	----------	-------------------

M45

V8 4.5L FI	VO-106		VCA-1044	NS ⁴³⁷
------------	--------	--	----------	-------------------

QX56

V8 5.6L FI	VO-106	VA-105	VCA-1048	NS ⁴³⁷
------------	--------	--------	----------	-------------------

2006

FX35

V6 3.5L FI	VO-106	VA-86	VCA-1068	NS ⁴³⁷
------------	--------	-------	----------	-------------------

FX45

V8 4.5L FI	VO-106	VA-370	VCA-1068	NS ⁴³⁷
------------	--------	--------	----------	-------------------

G35

V6 3.5L FI	VO-106	VA-86	VCA-1068	NS ⁴³⁷
------------	--------	-------	----------	-------------------

M35

V6 3.5L FI	VO-106	VA-282	VCA-1044	NS ⁴³⁷
------------	--------	--------	----------	-------------------

M45

V8 4.5L FI	VO-106		VCA-1044	NS ⁴³⁷
------------	--------	--	----------	-------------------

Q45

V8 4.5L FI	VO-106	VA-370	VCA-1044	NS ⁴³⁷
------------	--------	--------	----------	-------------------

QX56

V8 5.6L FI	VO-106	VA-105	VCA-1048	NS ⁴³⁷
------------	--------	--------	----------	-------------------

2005

FX35

V6 3.5L FI	VO-106	VA-86	VCA-1068	NS ⁴³⁷
------------	--------	-------	----------	-------------------

FX45

V8 4.5L FI	VO-106	VA-370	VCA-1068	NS ⁴³⁷
------------	--------	--------	----------	-------------------

G35

V6 3.5L FI	VO-106	VA-86	VCA-1068	NS ⁴³⁷
------------	--------	-------	----------	-------------------

Q45

V8 4.5L FI	VO-106	VA-370	VCA-1044	NS ⁴³⁷
------------	--------	--------	----------	-------------------

QX56

V8 5.6L FI	VO-106	VA-105	VCA-1048	NS ⁴³⁷
------------	--------	--------	----------	-------------------

2004

FX35

V6 3.5L FI	VO-106	VA-86	VCA-1068	NS ⁴³⁷
------------	--------	-------	----------	-------------------

FX45

V8 4.5L FI	VO-106	VA-370	VCA-1068	NS ⁴³⁷
------------	--------	--------	----------	-------------------

G35

V6 3.5L FI	VO-106	VA-86	VCA-1068	NS ⁴³⁷
------------	--------	-------	----------	-------------------

I35

V6 3.5L FI	VO-106	VA-86	VCA-1096	NS ⁴³⁷
------------	--------	-------	----------	-------------------

M45

V8 4.5L FI	VO-106	VA-370	VCA-1044 ⁷⁶²	NS ⁴³⁷
------------	--------	--------	-------------------------	-------------------

Se reporter à table de matière pour les notes en bas de page en français. Utilize el contenido para ver notas a pie.

NS - Non-Serviceable / Non réparable / No reparable LF - Life-Time Filter / Filtro para toda la vida / Filtre à vie

⁴³⁷ Requires replacement of the complete fuel pump/fuel filter module. ⁷⁶² Dust filter standard control. ^{X048} Sedan only (Requires two filters). ^{Z048} Coupe.



INFINITI (cont'd)

	Oil	Air	Cabin*	Fuel
2004				
Q45				
V8 4.5L FI	VO-106	VA-370	VCA-1044	NS ⁴³⁷
QX56				
V8 5.6L FI	VO-106	VA-105	VCA-1048	NS ⁴³⁷
2003				
FX35				
V6 3.5L FI	VO-106	VA-86	VCA-1068	NS ⁴³⁷
FX45				
V8 4.5L FI	VO-106	VA-370	VCA-1068	NS ⁴³⁷
G35				
V6 3.5L FI	VO-106	VA-86	VCA-1068	NS ⁴³⁷
I35				
V6 3.5L FI	VO-106	VA-86	VCA-1096	NS ⁴³⁷
M45				
V8 4.5L FI	VO-106	VA-370	VCA-1044 ⁷⁶²	NS ⁴³⁷
Q45				
V8 4.5L FI	VO-106	VA-370	VCA-1044	NS ⁴³⁷
QX4				
V6 3.5L FI	VO-106	VA-86	VCA-1039	
2002				
G20				
4 cyl. 2.0L FI	VO-106	VA-86	VCA-1039	
I35				
V6 3.5L FI	VO-106	VA-86	VCA-1096	NS ⁴³⁷
Q45				
V8 4.5L FI	VO-106	VA-370	VCA-1044	NS ⁴³⁷
QX4				
V6 3.5L FI	VO-106	VA-86	VCA-1039	
2001				
G20				
4 cyl. 2.0L FI	VO-106	VA-86	VCA-1039	
I30				
V6 3.0L FI	VO-106	VA-86	VCA-1096	NS ⁴³⁷
Q45				
V8 4.1L FI	VO-106	VA-370		NS ⁴³⁷
QX4				
V6 3.5L FI	VO-106	VA-86	VCA-1039	
2000				
G20				
4 cyl. 2.0L FI	VO-106	VA-86	VCA-1039	
I30				
V6 3.0L FI	VO-106	VA-86	VCA-1096	NS ⁴³⁷
Q45				
V8 4.1L FI	VO-106	VA-370		NS ⁴³⁷
QX4				
V6 3.3L FI	VO-106	VA-86	VCA-1039	
1999				
G20				
4 cyl. 2.0L FI	VO-106	VA-86	VCA-1039	
I30				
V6 3.0L FI	VO-106	VA-86		

Se reporter à table de matière pour les notes en bas de page en français. Utilize el contenido para ver notas a pie.

NS - Non-Serviceable / Non réparable / No reparable LF - Life-Time Filter / Filtro para toda la vida / Filtre à vie

⁴³⁷ Requires replacement of the complete fuel pump/fuel filter module. ⁷⁶² Dust filter standard control.



INFINITI (cont'd)

1999

Q45

V8 4.1L FI	VO-106	VA-370		
------------	--------	--------	--	--

QX4

V6 3.3L FI	VO-106	VA-86	VCA-1039	
------------	--------	-------	----------	--

1998

I30

V6 3.0L FI	VO-106	VA-86		
------------	--------	-------	--	--

Q45

V8 4.1L FI	VO-106	VA-370		
------------	--------	--------	--	--

QX4

V6 3.3L FI	VO-106	VA-86	VCA-1039	
------------	--------	-------	----------	--

1997

I30

V6 3.0L FI	VO-106	VA-86		
------------	--------	-------	--	--

J30

V6 3.0L FI	VO-25	VA-86		
------------	-------	-------	--	--

Q45

V8 4.1L FI	VO-106	VA-370		
------------	--------	--------	--	--

QX4

V6 3.3L FI	VO-106	VA-86	VCA-1039	
------------	--------	-------	----------	--

1996

G20

4 cyl. 2.0L FI	VO-147	VA-86		
----------------	--------	-------	--	--

I30

V6 3.0L FI	VO-106	VA-86		
------------	--------	-------	--	--

J30

V6 3.0L FI	VO-25	VA-86		
------------	-------	-------	--	--

Q45

V8 4.5L FI	VO-25	VA-370		
------------	-------	--------	--	--

1995

G20

4 cyl. 2.0L FI	VO-147	VA-86		
----------------	--------	-------	--	--

J30

V6 3.0L FI	VO-25	VA-86		
------------	-------	-------	--	--

Q45

V8 4.5L FI	VO-25	VA-370		
------------	-------	--------	--	--

ISUZU

2008

Ascender

6 cyl. 4.2L FI	VO-108	VA-161		NS ⁴³⁷
----------------	--------	--------	--	-------------------

I290

4 cyl. 2.9L FI	VO-58	VA-219		NS ⁴³⁷
----------------	-------	--------	--	-------------------

I370

5 cyl. 3.7L FI	VO-108	VA-219		NS ⁴³⁷
----------------	--------	--------	--	-------------------

2007

Ascender

6 cyl. 4.2L FI	VO-108	VA-161		NS ⁴³⁷
----------------	--------	--------	--	-------------------

I290

4 cyl. 2.9L FI	VO-58	VA-181		NS ⁴³⁷
----------------	-------	--------	--	-------------------

I370

5 cyl. 3.7L FI	VO-108	VA-181		NS ⁴³⁷
----------------	--------	--------	--	-------------------

Se reporter à table de matière pour les notes en bas de page en français. Utilize el contenido para ver notas a pie.

NS - Non-Serviceable / Non réparable / No reparable LF - Life-Time Filter / Filtro para toda la vida / Filtre à vie

⁴³⁷ Requires replacement of the complete fuel pump/fuel filter module.



ISUZU (cont'd)

	Oil	Air	Cabin*	Fuel
2006				
Ascender				
6 cyl. 4.2L FI	VO-108	VA-161		NS ⁴³⁷
V8 5.3L FI	VO-58	VA-161		NS ⁴³⁷
I280				
4 cyl. 2.8L FI	VO-58	VA-181		NS ⁴³⁷
I350				
5 cyl. 3.5L FI	VO-108	VA-181		NS ⁴³⁷
2005				
Ascender				
6 cyl. 4.2L FI	VO-108	VA-161		NS ⁴³⁷
V8 5.3L FI	VO-58	VA-161		NS ⁴³⁷
2004				
Ascender				
6 cyl. 4.2L FI	VO-108	VA-161		
V8 5.3L FI	VO-58	VA-161		
Axiom				
V6 3.5L FI	VO-106	VFAP-7859		
Rodeo				
V6 3.2L FI	VO-106	VFAP-7859		
V6 3.5L FI	VO-106	VFAP-7859		
2003				
Ascender				
6 cyl. 4.2L FI	VO-108	VA-161		
V8 5.3L FI	VO-58	VA-161		
Axiom				
V6 3.5L FI	VO-106	VFAP-7859		
Rodeo, Rodeo Sport				
4 cyl. 2.2L FI	VO-16	VFAP-7859		
V6 3.2L FI	VO-106	VFAP-7859		
2002				
Axiom				
V6 3.5L FI	VO-106	VFAP-7859		
Rodeo, Rodeo Sport				
4 cyl. 2.2L FI	VO-16	VFAP-7859		
V6 3.2L FI	VO-106	VFAP-7859		
Trooper				
V6 3.5L FI	VO-106	VFAP-7859		
2001				
Rodeo, Rodeo Sport				
4 cyl. 2.2L FI	VO-16	VFAP-7859		
V6 3.2L FI	VO-106	VFAP-7859		
Trooper				
V6 3.5L FI	VO-106	VFAP-7859		
Vehicross				
V6 3.5L FI	VO-106	VFAP-7859		
2000				
Amigo				
4 cyl. 2.2L FI	VO-16	VFAP-7859		
V6 3.2L FI	VO-106	VFAP-7859		
Hombre				
4 cyl. 2.2L FI	VO-16	VA-108		
V6 4.3L FI	VO-55	VA-108		

Se reporter à table de matière pour les notes en bas de page en français. Utilize el contenido para ver notas a pie.

NS - Non-Serviceable / Non réparable / No repairable LF - Life-Time Filter / Filtro para toda la vida / Filtre à vie

⁴³⁷ Requires replacement of the complete fuel pump/fuel filter module.



ISUZU (cont'd)

2000

Rodeo

4 cyl. 2.2L FI	VO-16	VFAP-7859		
V6 3.2L FI	VO-106	VFAP-7859		

Trooper

V6 3.5L FI	VO-106	VFAP-7859		
------------	--------	-----------	--	--

Vehicross

V6 3.5L FI	VO-106	VFAP-7859		
------------	--------	-----------	--	--

1999

Amigo

4 cyl. 2.2L FI	VO-16	VFAP-7859		
V6 3.2L FI	VO-106	VFAP-7859		

Hombre

4 cyl. 2.2L FI	VO-16	VA-108		
V6 4.3L FI	VO-55	VA-108		

Oasis

4 cyl. 2.3L FI	VO-106	VA-113		
----------------	--------	--------	--	--

Rodeo

4 cyl. 2.2L FI	VO-16	VFAP-7859		
V6 3.2L FI	VO-106	VFAP-7859		

Trooper

V6 3.5L FI	VO-106	VFAP-7859		
------------	--------	-----------	--	--

Vehicross

V6 3.5L FI	VO-106	VFAP-7859		
------------	--------	-----------	--	--

1998

Amigo

4 cyl. 2.2L FI	VO-16	VFAP-7859		
V6 3.2L FI	VO-106	VFAP-7859		

Hombre

4 cyl. 2.2L FI	VO-16	VA-108		
V6 4.3L FI	VO-55	VA-108		

Oasis

4 cyl. 2.3L FI	VO-106	VA-113		
----------------	--------	--------	--	--

Rodeo

4 cyl. 2.2L FI	VO-16	VFAP-7859		
V6 3.2L FI	VO-106	VFAP-7859		

Trooper

V6 3.5L FI	VO-106	VFAP-7859		
------------	--------	-----------	--	--

1997

Hombre

4 cyl. 2.2L FI	VO-16	VA-108		VG-14
V6 4.3L FI	VO-55	VA-108		VG-14

Oasis

4 cyl. 2.2L FI	VO-106	VA-113		
----------------	--------	--------	--	--

Rodeo

4 cyl. 2.6L FI	VO-106			
V6 3.2L FI	VO-106	VFAP-7859		

Trooper

V6 3.2L FI	VO-106	VFAP-7859		
------------	--------	-----------	--	--

1996

Hombre

4 cyl. 2.2L FI	VO-16	VA-108		VG-14
----------------	-------	--------	--	-------

Se reporter à table de matière pour les notes en bas de page en français. Utilize el contenido para ver notas a pie.
NS - Non-Serviceable / Non réparable / No reparable LF - Life-Time Filter / Filtro para toda la vida / Filtre à vie



ISUZU (cont'd)

1996				
Oasis				
4 cyl. 2.2L FI	VO-106	VA-113		
Rodeo				
4 cyl. 2.6L FI	VO-106			
V6 3.2L FI	VO-106	VFAP-7859		
Trooper				
V6 3.2L FI	VO-106	VFAP-7859		
1995				
Pickup				
4 cyl. 2.3L FI	VO-106	VA-408		
4 cyl. 2.6L FI	VO-106	VA-408		
Rodeo				
4 cyl. 2.6L FI	VO-106	VA-408		
V6 3.2L FI	VO-106	VFAP-7859		
Trooper				
V6 3.2L FI	VO-106	VFAP-7859		
1994				
Rodeo				
4 cyl. 2.6L FI	VO-106	VA-408		

JAGUAR

2019				
I-Pace				
-- Electric			VCA-1031	
E-Pace				
4 cyl. 2.0L Turbo			VCA-1158 ^{X344} VCA-1108 ^{Z344}	
F-Pace				
4 cyl. 2.0 Diesel			VCA-1031	
4 cyl. 2.0L GAS			VCA-1031	NS ⁴³⁷
V6 3.0L Supercharged	VO-141		VCA-1031	NS ⁴³⁷
V8 5.0L	VO-141		VCA-1031	NS ⁴³⁷
F-Type				
V6 3.0 Supercharged	VO-141			NS ⁴³⁷
V8 5.0 Supercharged	VO-141			
XE				
4 cyl. 2.0L Diesel			VCA-1031	
4 cyl. 2.0L GAS			VCA-1031	NS ⁴³⁷
V6 3.0L Supercharged	VO-141		VCA-1031	NS ⁴³⁷
XF				
4 cyl. 2.0L GAS	VO-25			NS ⁴³⁷
V6 3.0L Supercharged	VO-141			NS ⁴³⁷
XJ				
V6 3.0L Supercharged	VO-141			NS ⁴³⁷
V8 5.0L Supercharged	VO-141			NS ⁴³⁷
XJR575				
V8 5.0L Supercharged	VO-141			NS ⁴³⁷
2018				
E-Pace				
4 cyl. 2.0L Turbo			VCA-1158 ^{X344} VCA-1108 ^{Z344}	
F-Pace				
4 cyl. 2.0 Diesel			VCA-1031	

Se reporter à table de matière pour les notes en bas de page en français. Utilize el contenido para ver notas a pie.

NS - Non-Serviceable / Non réparable / No reparable LF - Life-Time Filter / Filtro para toda la vida / Filtre à vie

⁴³⁷ Requires replacement of the complete fuel pump/fuel filter module. ^{X344}Dust filter. ^{Z344}Dust and odor filter.



JAGUAR (cont'd)

2018

F-Pace

4 cyl. 2.0L GAS			VCA-1031	NS ⁴³⁷
V6 3.0L Supercharged	VO-141		VCA-1031	NS ⁴³⁷

F-Type

V6 3.0 Supercharged	VO-141			NS ⁴³⁷
V8 5.0 Supercharged	VO-141			

XE

4 cyl. 2.0L Diesel			VCA-1031	
4 cyl. 2.0L GAS			VCA-1031	NS ⁴³⁷
V6 3.0L Supercharged	VO-141		VCA-1031	NS ⁴³⁷

XF

4 cyl. 2.0L GAS	VO-25			NS ⁴³⁷
V6 3.0L Supercharged	VO-141			NS ⁴³⁷

XJ

V6 3.0L Supercharged	VO-141			NS ⁴³⁷
V8 5.0L Supercharged	VO-141			NS ⁴³⁷

XJR575

V8 5.0L Supercharged	VO-141			NS ⁴³⁷
----------------------	--------	--	--	-------------------

2017

F-Pace

V6 3.0L Supercharged	VO-141			NS ⁴³⁷
----------------------	--------	--	--	-------------------

F-Type

V6 3.0 Supercharged	VO-141			NS ⁴³⁷
V8 5.0 Supercharged	VO-141			

XE

4 cyl. 2.0L Diesel			VCA-1031	
4 cyl. 2.0L GAS	VO-25		VCA-1031	NS ⁴³⁷
V6 3.0L Supercharged	VO-141		VCA-1031	NS ⁴³⁷

XF

V6 3.0L Supercharged	VO-141			NS ⁴³⁷
----------------------	--------	--	--	-------------------

XJ

V6 3.0L Supercharged	VO-141			NS ⁴³⁷
V8 5.0L Supercharged	VO-141			NS ⁴³⁷

XJR

V8 5.0L Supercharged	VO-141			NS ⁴³⁷
----------------------	--------	--	--	-------------------

2016

F-Type

V6 3.0 Supercharged	VO-141			NS ⁴³⁷
V8 5.0 Supercharged	VO-141			NS ⁴³⁷

XF

V6 3.0L Supercharged	VO-141			NS ⁴³⁷
----------------------	--------	--	--	-------------------

XJ

V6 3.0L Supercharged	VO-141			NS ⁴³⁷
V8 5.0L Supercharged	VO-141			NS ⁴³⁷

XJR

V8 5.0L Supercharged	VO-141			NS ⁴³⁷
----------------------	--------	--	--	-------------------

2015

F-Type

V6 3.0 Supercharged	VO-141			NS ⁴³⁷
V8 5.0 Supercharged	VO-141			NS ⁴³⁷

XF

4 cyl. 2.0L Turbo	VO-25			NS ⁴³⁷
-------------------	-------	--	--	-------------------

Se reporter à table de matière pour les notes en bas de page en français. Utilize el contenido para ver notas a pie.

NS - Non-Serviceable / Non réparable / No reparable LF - Life-Time Filter / Filtro para toda la vida / Filtre à vie

⁴³⁷ Requires replacement of the complete fuel pump/fuel filter module.



JAGUAR (cont'd)

	Oil	Air	Cabin*	Fuel
2015				
XF				
V6 3.0L Supercharged	VO-141			NS ⁴³⁷
V8 5.0L Supercharged	VO-141			NS ⁴³⁷
XFR				
V8 5.0L Supercharged	VO-141			NS ⁴³⁷
XJ				
V6 3.0L Supercharged	VO-141			NS ⁴³⁷
V8 5.0L Supercharged	VO-141			NS ⁴³⁷
XJR				
V8 5.0L Supercharged	VO-141			NS ⁴³⁷
XK				
V8 5.0L	VO-141			NS ⁴³⁷
XKR				
V8 5.0L Supercharged	VO-141			NS ⁴³⁷
2014				
F-Type				
V6 3.0 Supercharged	VO-141			NS ⁴³⁷
V8 5.0 Supercharged	VO-141			NS ⁴³⁷
XF				
4 cyl. 2.0L Turbo	VO-25			NS ⁴³⁷
V6 3.0L Supercharged	VO-141			NS ⁴³⁷
V8 5.0L Supercharged	VO-141			NS ⁴³⁷
XFR				
V8 5.0L Supercharged	VO-141			NS ⁴³⁷
XJ				
V6 3.0L Supercharged	VO-141			NS ⁴³⁷
V8 5.0L Supercharged	VO-141			NS ⁴³⁷
XJR				
V8 5.0L Supercharged	VO-141			NS ⁴³⁷
XK				
V8 5.0L	VO-141			NS ⁴³⁷
XKR				
V8 5.0L Supercharged	VO-141			NS ⁴³⁷
2013				
XF				
4 cyl. 2.0L Turbo	VO-25			NS ⁴³⁷
V6 3.0L Supercharged	VO-141			NS ⁴³⁷
V8 5.0L Supercharged	VO-141			NS ⁴³⁷
XFR				
V8 5.0L Supercharged	VO-141			NS ⁴³⁷
XJ				
V6 3.0L Supercharged	VO-141			NS ⁴³⁷
V8 5.0L	VO-141			NS ⁴³⁷
V8 5.0L Supercharged	VO-141			NS ⁴³⁷
XK				
V8 5.0L	VO-141			NS ⁴³⁷
XKR				
V8 5.0L Supercharged	VO-141			NS ⁴³⁷
2012				
XF				
V8 5.0L	VO-141			NS ⁴³⁷
V8 5.0L Supercharged	VO-141			NS ⁴³⁷

Se reporter à table de matière pour les notes en bas de page en français. Utilize el contenido para ver notas a pie.

NS - Non-Serviceable / Non réparable / No reparable LF - Life-Time Filter / Filtro para toda la vida / Filtre à vie

⁴³⁷ Requires replacement of the complete fuel pump/fuel filter module.



JAGUAR (cont'd)

2012

XFR

V8 5.0L Supercharged	VO-141			NS ⁴³⁷
----------------------	--------	--	--	-------------------

XJ

V8 5.0L	VO-141			NS ⁴³⁷
---------	--------	--	--	-------------------

V8 5.0L Supercharged	VO-141			NS ⁴³⁷
----------------------	--------	--	--	-------------------

XK

V8 5.0L	VO-141			NS ⁴³⁷
---------	--------	--	--	-------------------

XKR

V8 5.0L Supercharged	VO-141			NS ⁴³⁷
----------------------	--------	--	--	-------------------

2011

XF

V8 5.0L	VO-141			NS ⁴³⁷
---------	--------	--	--	-------------------

V8 5.0L Supercharged	VO-141			NS ⁴³⁷
----------------------	--------	--	--	-------------------

XFR

V8 5.0L Supercharged	VO-141			NS ⁴³⁷
----------------------	--------	--	--	-------------------

XJ

V8 5.0L	VO-141			NS ⁴³⁷
---------	--------	--	--	-------------------

V8 5.0L Supercharged	VO-141			NS ⁴³⁷
----------------------	--------	--	--	-------------------

XK

V8 5.0L	VO-141			NS ⁴³⁷
---------	--------	--	--	-------------------

XKR

V8 5.0L Supercharged	VO-141			NS ⁴³⁷
----------------------	--------	--	--	-------------------

2010

XF

V8 4.2L	VO-86			
---------	-------	--	--	--

V8 5.0L	VO-141			
---------	--------	--	--	--

V8 5.0L Supercharged	VO-141			
----------------------	--------	--	--	--

XFR

V8 5.0L Supercharged	VO-141			
----------------------	--------	--	--	--

XJ

V8 5.0L	VO-141			NS ⁴³⁷
---------	--------	--	--	-------------------

V8 5.0L Supercharged	VO-141			NS ⁴³⁷
----------------------	--------	--	--	-------------------

XK

V8 5.0L	VO-141			
---------	--------	--	--	--

XKR

V8 5.0L Supercharged	VO-141			NS ⁴³⁷
----------------------	--------	--	--	-------------------

2009

Super V8

V8 4.2L FI (S.C.)	VO-86			VG-14
-------------------	-------	--	--	-------

Vanden Plas

V8 4.2L FI	VO-86			VG-14
------------	-------	--	--	-------

XF

V8 4.2L	VO-86			
---------	-------	--	--	--

V8 4.2L Supercharged	VO-86			
----------------------	-------	--	--	--

XJ8, XJ8L

V8 4.2L FI	VO-86			VG-14
------------	-------	--	--	-------

XJR

V8 4.2L FI (S.C.)	VO-86			VG-14
-------------------	-------	--	--	-------

XK

V8 4.2L	VO-86			
---------	-------	--	--	--

XKR

V8 4.2L FI (S.C.)	VO-86			NS ⁴³⁷
-------------------	-------	--	--	-------------------

Se reporter à table de matière pour les notes en bas de page en français. Utilize el contenido para ver notas a pie.

NS - Non-Serviceable / Non réparable / No reparable LF - Life-Time Filter / Filtro para toda la vida / Filtre à vie

⁴³⁷ Requires replacement of the complete fuel pump/fuel filter module.



JAGUAR (cont'd)

	Oil	Air	Cabin*	Fuel
2008				
S-Type				
V6 3.0L FI	VO-118		VCA-1131	
V8 4.2L FI	VO-86		VCA-1131	
V8 4.2L FI (S.C.)	VO-86		VCA-1131	
Super V8				
V8 4.2L FI (S.C.)	VO-86			VG-14
Vanden Plas				
V8 4.2L FI	VO-86			VG-14
X-Type				
V6 3.0L FI	VO-118	VA-363		
XJ8, XJ8L				
V8 4.2L FI	VO-86			VG-14
XJR				
V8 4.2L FI (S.C.)	VO-86			VG-14
XK				
V8 4.2L	VO-86			
XKR				
V8 4.2L FI (S.C.)	VO-86			NS ⁴³⁷
2007				
S-Type				
V6 3.0L FI	VO-118		VCA-1131	
V8 4.2L FI	VO-86		VCA-1131	
V8 4.2L FI (S.C.)	VO-86		VCA-1131	
Super V8				
V8 4.2L FI (S.C.)	VO-86			VG-14
Vanden Plas				
V8 4.2L FI	VO-86			VG-14
X-Type				
V6 3.0L FI	VO-118	VA-363		
XJ8, XJ8L				
V8 4.2L FI	VO-86			VG-14
XJR				
V8 4.2L FI (S.C.)	VO-86			VG-14
XK				
V8 4.2L	VO-86			
XKR				
V8 4.2L FI (S.C.)	VO-86			NS ⁴³⁷
2006				
S-Type				
V6 3.0L FI	VO-118		VCA-1131	
V8 4.2L FI	VO-86		VCA-1131	
V8 4.2L FI (S.C.)	VO-86		VCA-1131	
Super V8				
V8 4.2L FI (S.C.)	VO-86			VG-14
Vanden Plas				
V8 4.2L FI	VO-86			VG-14
X-Type				
V6 3.0L FI	VO-118	VA-363		
XJ8, XJ8L				
V8 4.2L FI	VO-86			VG-14
XJR				
V8 4.2L FI (S.C.)	VO-86			VG-14

Se reporter à table de matière pour les notes en bas de page en français. Utilize el contenido para ver notas a pie.

NS - Non-Serviceable / Non réparable / No repairable LF - Life-Time Filter / Filtro para toda la vida / Filtre à vie

⁴³⁷ Requires replacement of the complete fuel pump/fuel filter module.



JAGUAR (cont'd)

2006

XK8

V8 4.2L FI	VO-86	VA-394		VG-14
------------	-------	--------	--	-------

XKR

V8 4.2L FI (S.C.)	VO-86	VA-394		VG-14
-------------------	-------	--------	--	-------

2005

S-Type

V6 3.0L FI	VO-118		VCA-1131	
------------	--------	--	----------	--

V8 4.2L FI	VO-86		VCA-1131	
------------	-------	--	----------	--

V8 4.2L FI (S.C.)	VO-86		VCA-1131	
-------------------	-------	--	----------	--

Super V8

V8 4.2L FI (S.C.)	VO-86			VG-14
-------------------	-------	--	--	-------

Vanden Plas

V8 4.2L FI	VO-86			VG-14
------------	-------	--	--	-------

X-Type

V6 2.5L FI	VO-118	VA-363		
------------	--------	--------	--	--

V6 3.0L FI	VO-118	VA-363		
------------	--------	--------	--	--

XJ8

V8 4.2L FI	VO-86			VG-14
------------	-------	--	--	-------

XJR

V8 4.2L FI (S.C.)	VO-86			VG-14
-------------------	-------	--	--	-------

XK8

V8 4.2L FI	VO-86	VA-394		
------------	-------	--------	--	--

XKR

V8 4.2L FI (S.C.)	VO-86	VA-394		VG-14
-------------------	-------	--------	--	-------

2004

S-Type

V6 3.0L FI	VO-118		VCA-1131	
------------	--------	--	----------	--

V8 4.2L FI	VO-86		VCA-1131	
------------	-------	--	----------	--

V8 4.2L FI (S.C.)	VO-86		VCA-1131	
-------------------	-------	--	----------	--

Vanden Plas

V8 4.2L FI	VO-86			VG-14
------------	-------	--	--	-------

X-Type

V6 2.5L FI	VO-118	VA-363		
------------	--------	--------	--	--

V6 3.0L FI	VO-118	VA-363		
------------	--------	--------	--	--

XJ8

V8 4.2L FI	VO-86			VG-14
------------	-------	--	--	-------

XJR

V8 4.2L FI (S.C.)	VO-86			VG-14
-------------------	-------	--	--	-------

XK8

V8 4.2L FI	VO-86	VA-394		VG-14
------------	-------	--------	--	-------

XKR

V8 4.2L FI (S.C.)	VO-86	VA-394		VG-14
-------------------	-------	--------	--	-------

2003

S-Type

V6 3.0L FI	VO-118	VA-142 ⁴⁹⁶	VCA-1131	
------------	--------	-----------------------	----------	--

V8 4.2L FI	VO-86	VA-142 ⁴⁹⁶	VCA-1131	
------------	-------	-----------------------	----------	--

V8 4.2L FI (S.C.)	VO-86		VCA-1131	
-------------------	-------	--	----------	--

Vanden Plas

V8 4.0L FI	VO-86	VA-394		VG-14
------------	-------	--------	--	-------

V8 4.0L FI (S.C.)	VO-86	VA-394		VG-14
-------------------	-------	--------	--	-------

X-Type

V6 2.5L FI	VO-118	VA-363		
------------	--------	--------	--	--

Se reporter à table de matière pour les notes en bas de page en français. Utilize el contenido para ver notas a pie.

NS - Non-Serviceable / Non réparable / No repairable LF - Life-Time Filter / Filtro para toda la vida / Filtre à vie

⁴⁹⁶ Before V.I.N. M45255.



JAGUAR (cont'd)

	Oil	Air	Cabin*	Fuel
2003				
X-Type				
V6 3.0L FI	VO-118	VA-363		
XJ8				
V8 4.0L FI	VO-86	VA-394		VG-14
XJR				
V8 4.0L FI (S.C.)	VO-86	VA-394		VG-14
XK8				
V8 4.2L FI	VO-86	VA-394		VG-14
XKR				
V8 4.2L FI (S.C.)	VO-86	VA-394		VG-14
2002				
S-Type				
V6 3.0L FI	VO-118	VA-142	VCA-1125	
V8 4.0L FI	VO-86	VA-142	VCA-1125	
Vanden Plas				
V8 4.0L FI	VO-86	VA-394		VG-14
V8 4.0L FI (S.C.)	VO-86	VA-394		VG-14
X-Type				
V6 2.5L FI	VO-118	VA-363		
V6 3.0L FI	VO-118	VA-363		
XJ8				
V8 4.0L FI	VO-86	VA-394		VG-14
XJR				
V8 4.0L FI (S.C.)	VO-86	VA-394		VG-14
XK8				
V8 4.0L FI	VO-86	VA-394		VG-14
XKR				
V8 4.0L FI (S.C.)	VO-86	VA-394		VG-14
2001				
S-Type				
V6 3.0L FI	VO-118	VA-142	VCA-1125	
V8 4.0L FI	VO-86	VA-142	VCA-1125	
Vanden Plas				
V8 4.0L FI	VO-86	VA-394		VG-14
V8 4.0L FI (S.C.)	VO-86	VA-394		VG-14
XJ8				
V8 4.0L FI	VO-86	VA-394		VG-14
XJR				
V8 4.0L FI (S.C.)	VO-86	VA-394		VG-14
XK8				
V8 4.0L FI	VO-86	VA-394		VG-14
XKR				
V8 4.0L FI (S.C.)	VO-86	VA-394		VG-14
2000				
S-Type				
V6 3.0L FI	VO-118	VA-142	VCA-1125	
V8 4.0L FI	VO-86	VA-142	VCA-1125	
Vanden Plas				
V8 4.0L FI	VO-86	VA-394		VG-14
V8 4.0L FI (S.C.)	VO-86	VA-394		VG-14
XJ8				
V8 4.0L FI	VO-86	VA-394		VG-14

Se reporter à table de matière pour les notes en bas de page en français. Utilize el contenido para ver notas a pie.

NS - Non-Serviceable / Non réparable / No repairable LF - Life-Time Filter / Filtro para toda la vida / Filtre à vie



JAGUAR (cont'd)

2000

XJR

V8 4.0L FI (S.C.)	VO-86	VA-394		VG-14
-------------------	-------	--------	--	-------

XK8

V8 4.0L FI	VO-86	VA-394		VG-14
------------	-------	--------	--	-------

XKR

V8 4.0L FI (S.C.)	VO-86	VA-394		VG-14
-------------------	-------	--------	--	-------

1999

Vanden Plas

V8 4.0L FI	VO-86	VA-394		VG-14
------------	-------	--------	--	-------

XJ8

V8 4.0L FI	VO-86	VA-394		VG-14
------------	-------	--------	--	-------

XJR

V8 4.0L FI (S.C.)	VO-86	VA-394		VG-14
-------------------	-------	--------	--	-------

XK8

V8 4.0L FI	VO-86	VA-394		VG-14
------------	-------	--------	--	-------

1998

Vanden Plas

V8 4.0L FI	VO-86	VA-394		VG-14
------------	-------	--------	--	-------

XJ8

V8 4.0L FI	VO-86	VA-394		VG-14
------------	-------	--------	--	-------

XJR

V8 4.0L FI (S.C.)	VO-86	VA-394		VG-14
-------------------	-------	--------	--	-------

XK8

V8 4.0L FI	VO-86	VA-394		VG-14
------------	-------	--------	--	-------

1997

Vanden Plas

6 cyl. 4.0L FI	VO-86			VG-14
----------------	-------	--	--	-------

XJ6

6 cyl. 4.0L FI	VO-86			VG-14
----------------	-------	--	--	-------

XJR

6 cyl. 4.0L FI (S.C.)	VO-86			VG-14
-----------------------	-------	--	--	-------

XK8

V8 4.0L FI	VO-86	VA-394		VG-14
------------	-------	--------	--	-------

1996

Vanden Plas

6 cyl. 4.0L FI	VO-86			VG-14
----------------	-------	--	--	-------

XJ12

V12 6.0L FI	VO-86			VG-14
-------------	-------	--	--	-------

XJ6

6 cyl. 4.0L FI	VO-86			VG-14
----------------	-------	--	--	-------

XJR

6 cyl. 4.0L FI (S.C.)	VO-86			VG-14
-----------------------	-------	--	--	-------

XJS

6 cyl. 4.0L FI	VO-86			VG-14
----------------	-------	--	--	-------

1995

Vanden Plas

6 cyl. 4.0L FI	VO-86			VG-14
----------------	-------	--	--	-------

XJ12

V12 6.0L FI	VO-86			VG-14
-------------	-------	--	--	-------

XJ6

6 cyl. 4.0L FI	VO-86			VG-14
----------------	-------	--	--	-------

Se reporter à table de matière pour les notes en bas de page en français. Utilize el contenido para ver notas a pie.

NS - Non-Serviceable / Non réparable / No reparable LF - Life-Time Filter / Filtro para toda la vida / Filtre à vie



JAGUAR (cont'd)

1995				
XJR				
6 cyl. 4.0L FI (S.C.)	VO-86			VG-14
XJS				
6 cyl. 4.0L FI	VO-86			VG-14
V12 6.0L FI	VO-86			VG-14

JEEP

2019				
Cherokee				
4 cyl. 2.0L Turbo	VO-88	VA-503	VCA-1024	NS ⁴³⁷
4 cyl. 2.4L	VO-88	VA-502	VCA-1024	NS ⁴³⁷
V6 3.2L	VO-114	VA-502	VCA-1024	NS ⁴³⁷
Compass				
4 cyl. 2.4L	VO-88	VA-455	VCA-1187	NS ⁴³⁷
Grand Cherokee				
V6 3.6L	VO-114	VA-273	VCA-1073	NS ⁴³⁷
V8 5.7L	VO-88	VA-273	VCA-1073	NS ⁴³⁷
V8 6.2L	VO-88		VCA-1073	NS ⁴³⁷
V8 6.4L	VO-88	VA-273	VCA-1073	NS ⁴³⁷
Renegade				
4 cyl. 1.3			VCA-1187	
4 cyl. 2.4L	VO-88	VA-455	VCA-1187	
Wrangler				
4 cyl. 2.0L	VO-88	VA-499		NS ⁴³⁷
V6 3.6L	VO-114	VA-499		NS ⁴³⁷
2018				
Cherokee				
4 cyl. 2.4L	VO-88	VA-434	VCA-1176	NS ⁴³⁷
V6 3.2L	VO-114	VA-434	VCA-1176	NS ⁴³⁷
Compass				
4 cyl. 2.4L	VO-88	VA-455	VCA-1187	NS ⁴³⁷
Grand Cherokee				
V6 3.0L Diesel Turbo	VO-142		VCA-1073	
V6 3.6L	VO-114	VA-273	VCA-1073	NS ⁴³⁷
V8 5.7L	VO-88	VA-273	VCA-1073	NS ⁴³⁷
V8 6.2L	VO-88		VCA-1073	NS ⁴³⁷
V8 6.4L	VO-88	VA-273	VCA-1073	NS ⁴³⁷
Renegade				
4 cyl. 1.4L	VO-116	VA-455	VCA-1187	
4 cyl. 2.4L	VO-88	VA-455	VCA-1187	
Wrangler JK				
V6 3.6L	VO-114	VA-258	VCA-1097	NS ⁴³⁷
Wrangler				
4 cyl. 2.0L	VO-88	VA-499		NS ⁴³⁷
V6 3.6L	VO-114	VA-499		NS ⁴³⁷
2017				
Cherokee				
4 cyl. 2.4L	VO-88	VA-434	VCA-1176	NS ⁴³⁷
V6 3.2L	VO-114	VA-434	VCA-1176	NS ⁴³⁷
Compass				
4 cyl. 2.0L	VO-88	VA-290	VCA-1069	NS ⁴³⁷
4 cyl. 2.4L DOHC	VO-88	VA-290	VCA-1069	NS ⁴³⁷
4 cyl. 2.4L SOHC	VO-88	VA-455	VCA-1187	NS ⁴³⁷

Se reporter à table de matière pour les notes en bas de page en français. Utilize el contenido para ver notas a pie.

NS - Non-Serviceable / Non réparable / No repairable LF - Life-Time Filter / Filtro para toda la vida / Filtre à vie

⁴³⁷ Requires replacement of the complete fuel pump/fuel filter module.



JEEP (cont'd)

2017

Grand Cherokee

V6 3.0L Diesel Turbo	VO-142		VCA-1073	
V6 3.6L FI Flex Fuel	VO-114	VA-273	VCA-1073	NS ⁴³⁷
V8 5.7L	VO-88	VA-273	VCA-1073	NS ⁴³⁷
V8 6.4L	VO-88	VA-273	VCA-1073	NS ⁴³⁷

Patriot

4 cyl 2.0L	VO-88	VA-290	VCA-1069	NS ⁴³⁷
4 cyl 2.4L	VO-88	VA-290	VCA-1069	NS ⁴³⁷

Renegade

4 cyl. 1.4L	VO-116	VA-455	VCA-1187	
4 cyl. 2.4L	VO-88	VA-455	VCA-1187	

Wrangler

V6 3.6L	VO-114	VA-258	VCA-1097	NS ⁴³⁷
---------	--------	--------	----------	-------------------

2016

Cherokee

4 cyl. 2.4L	VO-88	VA-434	VCA-1176	NS ⁴³⁷
V6 3.2L	VO-114	VA-434	VCA-1176	NS ⁴³⁷

Compass

4 cyl 2.0L	VO-88	VA-290	VCA-1069	NS ⁴³⁷
4 cyl 2.4L	VO-88	VA-290	VCA-1069	NS ⁴³⁷

Grand Cherokee

V6 3.0L Diesel Turbo	VO-142		VCA-1073	
V6 3.6L FI Flex Fuel	VO-114	VA-273	VCA-1073	NS ⁴³⁷
V8 5.7L	VO-88	VA-273	VCA-1073	NS ⁴³⁷
V8 6.4L	VO-88	VA-273	VCA-1073	NS ⁴³⁷

Patriot

4 cyl 2.0L	VO-88	VA-290	VCA-1069	NS ⁴³⁷
4 cyl 2.4L	VO-88	VA-290	VCA-1069	NS ⁴³⁷

Renegade

4 cyl. 1.4L	VO-116	VA-455	VCA-1187	
4 cyl. 2.4L	VO-88	VA-455	VCA-1187	

Wrangler

V6 3.6L	VO-114	VA-258	VCA-1097	NS ⁴³⁷
---------	--------	--------	----------	-------------------

2015

Cherokee

4 cyl. 2.4L	VO-88	VA-434	VCA-1176	NS ⁴³⁷
V6 3.2L	VO-114	VA-434	VCA-1176	NS ⁴³⁷

Compass

4 cyl 2.0L	VO-88	VA-290	VCA-1069	NS ⁴³⁷
4 cyl 2.4L	VO-88	VA-290	VCA-1069	NS ⁴³⁷

Grand Cherokee

V6 3.0L Diesel Turbo	VO-142		VCA-1073	
V6 3.6L (Flex Fuel)	VO-114	VA-273	VCA-1073	NS ⁴³⁷
V8 5.7L	VO-88	VA-273	VCA-1073	NS ⁴³⁷
V8 6.4L	VO-88	VA-273	VCA-1073	NS ⁴³⁷

Patriot

4 cyl 2.0L	VO-88	VA-290	VCA-1069	NS ⁴³⁷
4 cyl 2.4L	VO-88	VA-290	VCA-1069	NS ⁴³⁷

Renegade

4 cyl. 1.4L	VO-116	VA-455	VCA-1187	
4 cyl. 2.4L	VO-88	VA-455	VCA-1187	

Se reporter à table de matière pour les notes en bas de page en français. Utilize el contenido para ver notas a pie.

NS - Non-Serviceable / Non réparable / No reparable LF - Life-Time Filter / Filtro para toda la vida / Filtre à vie

⁴³⁷ Requires replacement of the complete fuel pump/fuel filter module.



JEEP (cont'd)

	Oil	Air	Cabin*	Fuel
2015				
Wrangler				
V6 3.6L	VO-114	VA-258	VCA-1097	NS ⁴³⁷
2014				
Cherokee				
4 cyl. 2.4L	VO-88	VA-434	VCA-1176	NS ⁴³⁷
V6 3.2L	VO-114	VA-434	VCA-1176	NS ⁴³⁷
Compass				
4 cyl 2.0L	VO-88	VA-290	VCA-1069	NS ⁴³⁷
4 cyl 2.4L	VO-88	VA-290	VCA-1069	NS ⁴³⁷
Grand Cherokee				
V6 3.0L Diesel Turbo	VO-142		VCA-1073	
V6 3.6L (Flex Fuel)	VO-114	VA-273	VCA-1073	NS ⁴³⁷
V8 5.7L	VO-88	VA-273	VCA-1073	NS ⁴³⁷
V8 6.4L	VO-88	VA-273	VCA-1073	NS ⁴³⁷
Patriot				
4 cyl 2.0L	VO-88	VA-290	VCA-1069	NS ⁴³⁷
4 cyl 2.4L	VO-88	VA-290	VCA-1069	NS ⁴³⁷
Wrangler				
V6 3.6L	VO-114	VA-258	VCA-1097	NS ⁴³⁷
2013				
Compass				
4 cyl 2.0L	VO-88	VA-290	VCA-1069	NS ⁴³⁷
4 cyl 2.4L	VO-88	VA-290	VCA-1069	NS ⁴³⁷
Grand Cherokee				
V6 3.6L (Flex Fuel)	VO-110	VA-273	VCA-1073	NS ⁴³⁷
V8 5.7L	VO-88	VA-273	VCA-1073	NS ⁴³⁷
V8 6.4L	VO-88	VA-273	VCA-1073	NS ⁴³⁷
Liberty				
V6 3.7L (K) (Mexico)	VO-88	VA-232	VCA-1093	NS ⁴³⁷
Patriot				
4 cyl 2.0L	VO-88	VA-290	VCA-1069	NS ⁴³⁷
4 cyl 2.4L	VO-88	VA-290	VCA-1069	NS ⁴³⁷
Wrangler				
V6 3.6L	VO-110	VA-258	VCA-1097	NS ⁴³⁷
2012				
Compass				
4 cyl 2.0L	VO-88	VA-290	VCA-1069	NS ⁴³⁷
4 cyl 2.4L	VO-88	VA-290	VCA-1069	NS ⁴³⁷
Grand Cherokee				
V6 3.6L (Flex Fuel)	VO-110	VA-273	VCA-1073	NS ⁴³⁷
V8 5.7L	VO-88	VA-273	VCA-1073	NS ⁴³⁷
V8 6.4L	VO-88	VA-273	VCA-1073	NS ⁴³⁷
Liberty				
V6 3.7L	VO-88	VA-232	VCA-1093	NS ⁴³⁷
Patriot				
4 cyl 2.0L	VO-88	VA-290	VCA-1069	NS ⁴³⁷
4 cyl 2.4L	VO-88	VA-290	VCA-1069	NS ⁴³⁷
Wrangler				
V6 3.6L	VO-110	VA-258	VCA-1097	NS ⁴³⁷
2011				
Compass				
4 cyl 2.0L	VO-88	VA-290	VCA-1069	NS ⁴³⁷

Se reporter à table de matière pour les notes en bas de page en français. Utilize el contenido para ver notas a pie.

NS - Non-Serviceable / Non réparable / No repairable LF - Life-Time Filter / Filtro para toda la vida / Filtre à vie

⁴³⁷ Requires replacement of the complete fuel pump/fuel filter module.



JEEP (cont'd)

2011

Compass

4 cyl 2.4L	VO-88	VA-290	VCA-1069	NS ⁴³⁷
------------	-------	--------	----------	-------------------

Grand Cherokee

V6 3.6L (Flex Fuel)	VO-110	VA-273	VCA-1073	NS ⁴³⁷
---------------------	--------	--------	----------	-------------------

V8 5.7L	VO-88	VA-273	VCA-1073	NS ⁴³⁷
---------	-------	--------	----------	-------------------

Liberty

V6 3.7L	VO-88	VA-232	VCA-1093	NS ⁴³⁷
---------	-------	--------	----------	-------------------

Patriot

4 cyl 2.0L	VO-88	VA-290	VCA-1069	NS ⁴³⁷
------------	-------	--------	----------	-------------------

4 cyl 2.4L	VO-88	VA-290	VCA-1069	NS ⁴³⁷
------------	-------	--------	----------	-------------------

Wrangler

V6 3.8L	VO-25	VA-258	VCA-1097	NS ⁴³⁷
---------	-------	--------	----------	-------------------

2010

Commander

V6 3.7L (K) FI	VO-88	VA-164		NS ⁴³⁷
----------------	-------	--------	--	-------------------

V8 5.7L (T) FI	VO-88	VA-164		NS ⁴³⁷
----------------	-------	--------	--	-------------------

Compass

4 cyl 2.0L	VO-88	VA-229	VCA-1069	NS ⁴³⁷
------------	-------	--------	----------	-------------------

4 cyl 2.4L	VO-88	VA-229	VCA-1069	NS ⁴³⁷
------------	-------	--------	----------	-------------------

Grand Cherokee

V6 3.7L	VO-88	VA-164	VCA-1170	NS ⁴³⁷
---------	-------	--------	----------	-------------------

V8 5.7L	VO-88	VA-164	VCA-1170	NS ⁴³⁷
---------	-------	--------	----------	-------------------

V8 6.1L	VO-88	VA-164	VCA-1170	NS ⁴³⁷
---------	-------	--------	----------	-------------------

Liberty

V6 3.7L	VO-88	VA-232	VCA-1093	NS ⁴³⁷
---------	-------	--------	----------	-------------------

Patriot

4 cyl 2.0L	VO-88	VA-229	VCA-1069	NS ⁴³⁷
------------	-------	--------	----------	-------------------

4 cyl 2.4L	VO-88	VA-229	VCA-1069	NS ⁴³⁷
------------	-------	--------	----------	-------------------

Wrangler

V6 3.8L	VO-25	VA-258		NS ⁴³⁷
---------	-------	--------	--	-------------------

2009

Commander

V6 3.7L (K) FI	VO-88	VA-164		NS ⁴³⁷
----------------	-------	--------	--	-------------------

V8 4.7L (N) FI	VO-88	VA-164		NS ⁴³⁷
----------------	-------	--------	--	-------------------

V8 4.7L (P) FI (Flex Fuel)	VO-88	VA-164		NS ⁴³⁷
----------------------------	-------	--------	--	-------------------

V8 5.7L (T) FI	VO-88	VA-164		NS ⁴³⁷
----------------	-------	--------	--	-------------------

Compass

4 cyl 2.0L (A) FI	VO-88	VA-229	VCA-1069	NS ⁴³⁷
-------------------	-------	--------	----------	-------------------

4 cyl 2.4L (B,W) FI	VO-88	VA-229	VCA-1069	NS ⁴³⁷
---------------------	-------	--------	----------	-------------------

Grand Cherokee

V6 3.0L (M) DI Turbo Diesel	VO-129	VA-164	VCA-1170	
-----------------------------	--------	--------	----------	--

V6 3.7L (K) FI	VO-88	VA-164	VCA-1170	NS ⁴³⁷
----------------	-------	--------	----------	-------------------

V8 4.7L (P) FI (Flex Fuel)	VO-88	VA-164	VCA-1170	NS ⁴³⁷
----------------------------	-------	--------	----------	-------------------

V8 5.7L (2,T) FI	VO-88	VA-164	VCA-1170	NS ⁴³⁷
------------------	-------	--------	----------	-------------------

V8 6.1L (W) FI	VO-88	VA-164	VCA-1170	NS ⁴³⁷
----------------	-------	--------	----------	-------------------

Liberty

V6 3.7L (K) FI	VO-88	VA-232	VCA-1093	NS ⁴³⁷
----------------	-------	--------	----------	-------------------

Patriot

4 cyl 2.0L (A) FI	VO-88	VA-229	VCA-1069	NS ⁴³⁷
-------------------	-------	--------	----------	-------------------

4 cyl 2.4L (B,W) FI	VO-88	VA-229	VCA-1069	NS ⁴³⁷
---------------------	-------	--------	----------	-------------------

Wrangler

V6 3.8L	VO-25	VA-258		NS ⁴³⁷
---------	-------	--------	--	-------------------

Se reporter à table de matière pour les notes en bas de page en français. Utilize el contenido para ver notas a pie.

NS - Non-Serviceable / Non réparable / No reparable LF - Life-Time Filter / Filtro para toda la vida / Filtre à vie

⁴³⁷ Requires replacement of the complete fuel pump/fuel filter module.



JEEP (cont'd)

	Oil	Air	Cabin*	Fuel
2008				
Commander				
V6 3.7L (K) FI	VO-118	VA-164		NS ⁴³⁷
V8 4.7L (N) FI	VO-88 ^{X370} VO-95 ^{1504, Z370}	VA-164		NS ⁴³⁷
V8 5.7L (2) FI	VO-88 ^{X370} VO-95 ^{1504, Z370}	VA-164		NS ⁴³⁷
Compass				
4 cyl 2.0L (O) FI	VO-88	VA-229	VCA-1069	NS ⁴³⁷
4 cyl 2.4L (W) FI	VO-88	VA-229	VCA-1069	NS ⁴³⁷
Grand Cherokee				
V6 3.0L (M) DI Turbo Diesel	VO-129	VA-164	VCA-1170	
V6 3.7L (K) FI	VO-118	VA-164	VCA-1170	NS ⁴³⁷
V8 4.7L (N) FI	VO-88	VA-164	VCA-1170	NS ⁴³⁷
V8 5.7L (2) FI	VO-88 ^{X370} VO-95 ^{1504, Z370}	VA-164	VCA-1170	NS ⁴³⁷
V8 6.1L (3) FI	VO-88 ^{X370} VO-95 ^{1504, Z370}	VA-164	VCA-1170	NS ⁴³⁷
Liberty				
V6 3.7L (K) FI	VO-118	VA-232	VCA-1093	NS ⁴³⁷
Patriot				
4 cyl 2.0L (O) FI	VO-88	VA-229	VCA-1069	NS ⁴³⁷
4 cyl 2.4L (W) FI	VO-88	VA-229	VCA-1069	NS ⁴³⁷
Wrangler				
V6 3.8L	VO-25	VA-258		NS ⁴³⁷
2007				
Commander				
V6 3.7L (K) FI	VO-118	VA-164		NS ⁴³⁷
V8 4.7L (N) FI	VO-95 ^{X504} VO-25 ^{Z504}	VA-164		NS ⁴³⁷
V8 4.7L (P) FI (Flex Fuel)	VO-95 ^{X504} VO-25 ^{Z504}	VA-164		NS ⁴³⁷
V8 5.7L (2) FI	VO-95 ^{X504} VO-25 ^{Z504}	VA-164		NS ⁴³⁷
Compass				
4 cyl 2.0L (O) FI	VO-88	VA-229	VCA-1069	NS ⁴³⁷
4 cyl 2.4L (W) FI	VO-88	VA-229	VCA-1069	NS ⁴³⁷
Grand Cherokee				
V6 3.0L DI Turbo Diesel	VO-129	VA-164	VCA-1170	
V6 3.7L (K) FI	VO-118	VA-164	VCA-1170	NS ⁴³⁷
V8 4.7L (N) FI	VO-95 ^{X504} VO-25 ^{Z504}	VA-164	VCA-1170	NS ⁴³⁷
V8 4.7L (P) FI (Flex Fuel)	VO-95 ^{X504} VO-25 ^{Z504}	VA-164	VCA-1170	NS ⁴³⁷
V8 5.7L (2) FI	VO-95 ^{X504} VO-25 ^{Z504}	VA-164	VCA-1170	NS ⁴³⁷
V8 6.1L (3) FI	VO-95 ^{X504} VO-25 ^{Z504}	VA-164	VCA-1170	NS ⁴³⁷
Liberty				
V6 3.7L (K) FI	VO-118	VA-164		NS ⁴³⁷
Patriot				
4 cyl 2.0L (O) FI	VO-88	VA-229	VCA-1069	NS ⁴³⁷
4 cyl 2.4L (W) FI	VO-88	VA-229	VCA-1069	NS ⁴³⁷

Se reporter à table de matière pour les notes en bas de page en français. Utilize el contenido para ver notas a pie.

NS - Non-Serviceable / Non réparable / No repairable LF - Life-Time Filter / Filtro para toda la vida / Filtre à vie

⁴³⁷ Requires replacement of the complete fuel pump/fuel filter module. ¹⁵⁰⁴Alternate. Primary VO-25 ^{X370}with 22 MM THREADED STUD ^{X504}Alternate

^{Z370}with 3/4 INCH THREADED STUD. ^{Z504}Primary



JEEP (cont'd)

2007

Wrangler

V6 3.8L	VO-25	VA-258		NS ⁴³⁷
---------	-------	--------	--	-------------------

2006

Commander

V6 3.7L (K) FI	VO-118	VA-164		NS ⁴³⁷
V8 4.7L (N) FI	VO-95 ^{X504}			
	VO-25 ^{Z504}	VA-164		NS ⁴³⁷
V8 5.7L (2) FI	VO-95 ^{X504}			
	VO-25 ^{Z504}	VA-164		NS ⁴³⁷

Grand Cherokee

V6 3.7L (K) FI	VO-118	VA-164	VCA-1170	NS ⁴³⁷
V8 4.7L (N) FI	VO-95 ^{X504}			
	VO-25 ^{Z504}	VA-164	VCA-1170	NS ⁴³⁷
V8 5.7L (2) FI	VO-95 ^{X504}			
	VO-25 ^{Z504}	VA-164	VCA-1170	NS ⁴³⁷
V8 6.1L (3) FI	VO-95 ^{X504}			
	VO-25 ^{Z504}	VA-164	VCA-1170	NS ⁴³⁷

Liberty

4 cyl. 2.8L (5) Diesel Turbo FI		VA-164		
V6 3.7L (K) FI	VO-118	VA-164		NS ⁴³⁷

TJ

4 cyl. 2.4L (1) FI (Canada)	VO-25			NS ⁴³⁷
6 cyl. 4.0L (S) FI (Canada)	VO-95 ^{X504}			
	VO-25 ^{Z504}	VA-129		NS ⁴³⁷

Wrangler

4 cyl. 2.4L (1) FI	VO-25			NS ⁴³⁷
6 cyl. 4.0L (S) FI	VO-95 ^{X504}			
	VO-25 ^{Z504}	VA-129		NS ⁴³⁷

2005

Grand Cherokee

V6 3.7L (K) FI	VO-118	VA-164	VCA-1170	
V8 4.7L (N) FI	VO-95 ^{X504}			
	VO-25 ^{Z504}	VA-164	VCA-1170	
V8 5.7L (2) FI	VO-95 ^{X504}			
	VO-25 ^{Z504}	VA-164	VCA-1170	

Liberty

4 cyl. 2.4L (1) FI	VO-25			NS ⁴³⁷
4 cyl. 2.8L (5) Diesel Turbo FI		VA-164		
V6 3.7L (K) FI	VO-118	VA-164		NS ⁴³⁷

TJ

4 cyl. 2.4L (1) FI (Canada)	VO-25			NS ⁴³⁷
6 cyl. 4.0L (S) FI (Canada)	VO-95 ^{X504}			
	VO-25 ^{Z504}	VA-129		NS ⁴³⁷

Wrangler

4 cyl. 2.4L (1) FI	VO-25			NS ⁴³⁷
6 cyl. 4.0L (S) FI	VO-95 ^{X504}			
	VO-25 ^{Z504}	VA-129		NS ⁴³⁷

2004

Grand Cherokee

6 cyl. 4.0L (S) FI	VO-95 ^{X504}			
	VO-25 ^{Z504}	VA-105	VCA-1170	
V8 4.7L (N) FI	VO-95 ^{X504}			
	VO-25 ^{Z504}	VA-105	VCA-1170	

Se reporter à table de matière pour les notes en bas de page en français. Utilize el contenido para ver notas a pie.

NS - Non-Serviceable / Non réparable / No repairable LF - Life-Time Filter / Filtro para toda la vida / Filtre à vie

⁴³⁷ Requires replacement of the complete fuel pump/fuel filter module. ^{X504}Alternate ^{Z504}Primary



JEEP (cont'd)

	Oil	Air	Cabin*	Fuel
2004				
Grand Cherokee				
V8 4.7L (J) FI (H.O.)	VO-95 ^{X504} VO-25 ^{Z504}	VA-342	VCA-1170	
Liberty				
4 cyl. 2.4L (1) FI	VO-25			
V6 3.7L (K) FI	VO-118	VA-164		
TJ				
6 cyl. 4.0L (S) FI (Canada)	VO-95 ^{X504} VO-25 ^{Z504}	VA-129		NS ⁴³⁷
Wrangler				
4 cyl. 2.4L (1) FI	VO-25			NS ⁴³⁷
6 cyl. 4.0L (S) FI	VO-95 ^{X504} VO-25 ^{Z504}	VA-129		NS ⁴³⁷
2003				
Grand Cherokee				
6 cyl. 4.0L (S) FI	VO-95 ^{X504} VO-25 ^{Z504}	VA-105	VCA-1170	
V8 4.7L (N) FI	VO-95 ^{X504} VO-25 ^{Z504}	VA-105	VCA-1170	
V8 4.7L (J) FI (H.O.)	VO-95 ^{X504} VO-25 ^{Z504}	VA-342	VCA-1170	
Liberty				
4 cyl. 2.4L (1) FI	VO-25			
V6 3.7L (K) FI	VO-118	VA-164		
TJ				
4 cyl. 2.4L (1) FI (Canada)	VO-25			NS ⁴³⁷
6 cyl. 4.0L (S) FI (Canada)	VO-95 ^{X504} VO-25 ^{Z504}	VA-129		NS ⁴³⁷
Wrangler				
4 cyl. 2.4L (1) FI	VO-25			NS ⁴³⁷
6 cyl. 4.0L (S) FI	VO-95 ^{X504} VO-25 ^{Z504}	VA-129		NS ⁴³⁷
2002				
Grand Cherokee				
6 cyl. 4.0L (S) FI	VO-95 ^{X504} VO-25 ^{Z504}	VA-105	VCA-1170	
V8 4.7L (N) FI	VO-95 ^{X504} VO-25 ^{Z504}	VA-105	VCA-1170	
V8 4.7L (J) FI (H.O.)	VO-95 ^{X504} VO-25 ^{Z504}	VA-342	VCA-1170	
Liberty				
4 cyl. 2.4L (1) FI	VO-25			
V6 3.7L (K) FI	VO-118	VA-164		
TJ				
4 cyl. 2.5L (P) FI (Canada)	VO-95 ^{X504} VO-25 ^{Z504}	VA-129		NS ⁴³⁷
6 cyl. 4.0L (S) FI (Canada)	VO-95 ^{X504} VO-25 ^{Z504}	VA-129		NS ⁴³⁷
Wrangler				
4 cyl. 2.5L (P) FI	VO-95 ^{X504} VO-25 ^{Z504}	VA-129		NS ⁴³⁷
6 cyl. 4.0L (S) FI	VO-95 ^{X504} VO-25 ^{Z504}	VA-129		NS ⁴³⁷

Se reporter à table de matière pour les notes en bas de page en français. Utilize el contenido para ver notas a pie.

NS - Non-Serviceable / Non réparable / No reparable LF - Life-Time Filter / Filtro para toda la vida / Filtre à vie

⁴³⁷ Requires replacement of the complete fuel pump/fuel filter module. ^{X504}Alternate ^{Z504}Primary



JEEP (cont'd)

2001

Cherokee

6 cyl. 4.0L (S) FI	VO-95 ^{X504} VO-25 ^{Z504}	VA-90		NS ⁴³⁷
--------------------	--	-------	--	-------------------

Grand Cherokee

6 cyl. 4.0L (S) FI	VO-95 ^{X504} VO-25 ^{Z504}	VA-105	VCA-1170	
V8 4.7L (N) FI	VO-95 ^{X504} VO-25 ^{Z504}	VA-105	VCA-1170	

TJ

4 cyl. 2.5L (P) FI (Canada)	VO-95 ^{X504} VO-25 ^{Z504}	VA-129		NS ⁴³⁷
6 cyl. 4.0L (S) FI (Canada)	VO-95 ^{X504} VO-25 ^{Z504}	VA-129		NS ⁴³⁷

Wrangler

4 cyl. 2.5L (P) FI	VO-95 ^{X504} VO-25 ^{Z504}	VA-129		NS ⁴³⁷
6 cyl. 4.0L (S) FI	VO-95 ^{X504} VO-25 ^{Z504}	VA-129		NS ⁴³⁷

2000

Cherokee

4 cyl. 2.5L (P) FI	VO-95 ^{X504} VO-25 ^{Z504}	VA-90		NS ⁴³⁷
6 cyl. 4.0L (S) FI	VO-95 ^{X504} VO-25 ^{Z504}	VA-90		NS ⁴³⁷

Grand Cherokee

6 cyl. 4.0L (S) FI	VO-95 ^{X504} VO-25 ^{Z504}	VA-105	VCA-1170	
V8 4.7L (N) FI	VO-95 ^{X504} VO-25 ^{Z504}	VA-105	VCA-1170	

TJ

4 cyl. 2.5L (P) FI (Canada)	VO-95 ^{X504} VO-25 ^{Z504}	VA-129		NS ⁴³⁷
6 cyl. 4.0L (S) FI (Canada)	VO-95 ^{X504} VO-25 ^{Z504}	VA-129		NS ⁴³⁷

Wrangler

4 cyl. 2.5L (P) FI	VO-95 ^{X504} VO-25 ^{Z504}	VA-129		NS ⁴³⁷
6 cyl. 4.0L (S) FI	VO-95 ^{X504} VO-25 ^{Z504}	VA-129		NS ⁴³⁷

1999

Cherokee

4 cyl. 2.5L (P) FI	VO-95 ^{X504} VO-25 ^{Z504}	VA-90		NS ⁴³⁷
6 cyl. 4.0L (S) FI	VO-95 ^{X504} VO-25 ^{Z504}	VA-90		NS ⁴³⁷

Grand Cherokee

6 cyl. 4.0L (S) FI	VO-95 ^{X504} VO-25 ^{Z504}	VA-105	VCA-1170	
V8 4.7L (N) FI	VO-95 ^{X504} VO-25 ^{Z504}	VA-105	VCA-1170	

TJ

4 cyl. 2.5L (P) FI (Canada)	VO-95 ^{X504} VO-25 ^{Z504}	VA-129		NS ⁴³⁷
-----------------------------	--	--------	--	-------------------

Se reporter à table de matière pour les notes en bas de page en français. Utilize el contenido para ver notas a pie.

NS - Non-Serviceable / Non réparable / No repairable LF - Life-Time Filter / Filtro para toda la vida / Filtre à vie

⁴³⁷ Requires replacement of the complete fuel pump/fuel filter module. ^{X504}Alternate ^{Z504}Primary



JEEP (cont'd)

1999				
TJ				
6 cyl. 4.0L (S) FI (Canada)	VO-95 ^{X504} VO-25 ^{Z504}	VA-129		NS ⁴³⁷
Wrangler				
4 cyl. 2.5L (P) FI	VO-95 ^{X504} VO-25 ^{Z504}	VA-129		NS ⁴³⁷
6 cyl. 4.0L (S) FI	VO-95 ^{X504} VO-25 ^{Z504}	VA-129		NS ⁴³⁷
1998				
Cherokee				
4 cyl. 2.5L (P) FI	VO-95 ^{X504} VO-25 ^{Z504}	VA-90		NS ⁴³⁷
6 cyl. 4.0L (S) FI	VO-95 ^{X504} VO-25 ^{Z504}	VA-90		NS ⁴³⁷
Grand Cherokee				
6 cyl. 4.0L (S) FI	VO-95 ^{X504} VO-25 ^{Z504}	VA-105		NS ⁴³⁷
V8 5.2L (Y) FI	VO-95 ^{X504} VO-25 ^{Z504}	VA-105		NS ⁴³⁷
V8 5.9L (Z) FI	VO-95 ^{X504} VO-25 ^{Z504}	VA-105		NS ⁴³⁷
TJ				
4 cyl. 2.5L FI (Canada)	VO-95 ^{X504} VO-25 ^{Z504}	VA-129		NS ⁴³⁷
6 cyl. 4.0L FI (Canada)	VO-95 ^{X504} VO-25 ^{Z504}	VA-129		NS ⁴³⁷
Wrangler				
4 cyl. 2.5L (P) FI	VO-95 ^{X504} VO-25 ^{Z504}	VA-129		NS ⁴³⁷
6 cyl. 4.0L (S) FI	VO-95 ^{X504} VO-25 ^{Z504}	VA-129		NS ⁴³⁷
1997				
Cherokee				
4 cyl. 2.5L (P) FI	VO-95 ^{X504} VO-25 ^{Z504}	VA-90		NS ⁴³⁷
6 cyl. 4.0L (S) FI	VO-95 ^{X504} VO-25 ^{Z504}	VA-90		NS ⁴³⁷
Grand Cherokee				
6 cyl. 4.0L (S) FI	VO-95 ^{X504} VO-25 ^{Z504}	VA-105		NS ⁴³⁷
V8 5.2L (Y) FI	VO-95 ^{X504} VO-25 ^{Z504}	VA-105		NS ⁴³⁷
TJ				
4 cyl. 2.5L FI (Canada)	VO-95 ^{X504} VO-25 ^{Z504}	VA-129		NS ⁴³⁷
6 cyl. 4.0L FI (Canada)	VO-95 ^{X504} VO-25 ^{Z504}	VA-129		NS ⁴³⁷
Wrangler				
4 cyl. 2.5L (P) FI	VO-95 ^{X504} VO-25 ^{Z504}	VA-129		NS ⁴³⁷
6 cyl. 4.0L (S) FI	VO-95 ^{X504} VO-25 ^{Z504}	VA-129		NS ⁴³⁷

Se reporter à table de matière pour les notes en bas de page en français. Utilize el contenido para ver notas a pie.

NS - Non-Serviceable / Non réparable / No reparable LF - Life-Time Filter / Filtro para toda la vida / Filtre à vie

⁴³⁷ Requires replacement of the complete fuel pump/fuel filter module. ^{X504}Alternate ^{Z504}Primary



JEEP (cont'd)

1996

Cherokee

4 cyl. 2.5L (P) FI	VO-95 ^{X504} VO-25 ^{Z504}	VA-90		
6 cyl. 4.0L (S) FI	VO-95 ^{X504} VO-25 ^{Z504}	VA-90		

Grand Cherokee

6 cyl. 4.0L (S) FI	VO-95 ^{X504} VO-25 ^{Z504}	VA-105		
V8 5.2L (Y) FI	VO-95 ^{X504} VO-25 ^{Z504}	VA-105		

1995

Cherokee

4 cyl. 2.5L (P) FI	VO-95 ^{X504} VO-25 ^{Z504}	VA-90		
6 cyl. 4.0L (S) FI	VO-95 ^{X504} VO-25 ^{Z504}	VA-90		

Grand Cherokee

6 cyl. 4.0L (S) FI	VO-95 ^{X504} VO-25 ^{Z504}	VA-105		
V8 5.2L (Y) FI	VO-95 ^{X504} VO-25 ^{Z504}	VA-105		

Wrangler

4 cyl. 2.5L (P) FI	VO-95 ^{X504} VO-25 ^{Z504}			
6 cyl. 4.0L (S) FI	VO-95 ^{X504} VO-25 ^{Z504}			

1994

Cherokee

6 cyl. 4.0L (S) FI	VO-95 ^{X504} VO-25 ^{Z504}	VA-90		
--------------------	--	-------	--	--

Grand Cherokee

6 cyl. 4.0L (S) FI	VO-95 ^{X504} VO-25 ^{Z504}	VA-105		
--------------------	--	--------	--	--

KIA

2019

Cadenza

V6 3.3L	VO-167		VCA-1181	NS ⁴³⁷
---------	--------	--	----------	-------------------

Forte

4 cyl. 2.0L	VO-148	VA-465	VCA-1191	NS ⁴³⁷
-------------	--------	--------	----------	-------------------

Niro

4 cyl. 1.6L Hybrid	VO-106			NS ⁴³⁷
--------------------	--------	--	--	-------------------

Optima

4 cyl. 1.6L Turbo	VO-106		VCA-1192	
4 cyl. 2.0L Turbo	VO-148		VCA-1192	NS ⁴³⁷
4 cyl. 2.0L (Hybrid)	VO-106	VA-417	VCA-1192	NS ⁴³⁷
4 cyl. 2.4L	VO-106	VA-417	VCA-1192	NS ⁴³⁷

Rio

4 cyl. 1.6L	VO-106		VCA-1191	NS ⁴³⁷
-------------	--------	--	----------	-------------------

Sedona

V6 3.3L	VO-167	VA-418	VCA-1075	NS ⁴³⁷
---------	--------	--------	----------	-------------------

Sorento

4 cyl. 2.4L	VO-106	VA-418	VCA-1188	NS ⁴³⁷
-------------	--------	--------	----------	-------------------

Se reporter à table de matière pour les notes en bas de page en français. Utilize el contenido para ver notas a pie.

NS - Non-Serviceable / Non réparable / No reparable LF - Life-Time Filter / Filtro para toda la vida / Filtre à vie

⁴³⁷ Requires replacement of the complete fuel pump/fuel filter module. ^{X504}Alternate ^{Z504}Primary



KIA (cont'd)

	Oil	Air	Cabin*	Fuel
2019				
Sorento				
V6 3.3L	VO-167	VA-418	VCA-1188	NS ⁴³⁷
Soul				
4 cyl. 1.6L	VO-106	VA-300	VCA-1179	NS ⁴³⁷
4 cyl. 2.0L	VO-148	VA-300	VCA-1179	NS ⁴³⁷
Soul EV				
-- Electric			VCA-1179	
Sportage				
4 cyl. 2.0L Turbo	VO-148	VA-458	VCA-1190	NS ⁴³⁷
4 cyl. 2.4L	VO-106	VA-458	VCA-1190	NS ⁴³⁷
Stinger				
4 cyl. 2.0L Turbo	VO-148		VCA-1062	NS ⁴³⁷
V6 3.3L Turbo			VCA-1062	NS ⁴³⁷
2018				
Cadenza				
V6 3.3L	VO-167		VCA-1181	NS ⁴³⁷
Forte				
4 cyl. 1.6L Turbo	VO-106		VCA-1051	NS ⁴³⁷
4 cyl. 2.0L	VO-148	VA-334	VCA-1051	NS ⁴³⁷
K900				
V6 3.8	VO-99	VA-358		
V8 5.0	VO-99	VA-358		
Niro				
4 cyl. 1.6L Hybrid	VO-106			NS ⁴³⁷
Optima				
4 cyl. 1.6L Turbo	VO-106		VCA-1192	
4 cyl. 2.0L Turbo	VO-148		VCA-1192	NS ⁴³⁷
4 cyl. 2.0L (Hybrid)	VO-148	VA-417	VCA-1192	NS ⁴³⁷
4 cyl. 2.4L	VO-106	VA-417	VCA-1192	NS ⁴³⁷
Rio				
4 cyl. 1.6L	VO-106		VCA-1191	NS ⁴³⁷
Sedona				
V6 3.3L	VO-109	VA-418	VCA-1075	NS ⁴³⁷
Sorento				
4 cyl. 2.0L Turbo	VO-148	VA-418	VCA-1188	NS ⁴³⁷
4 cyl. 2.4L	VO-106	VA-418	VCA-1188	NS ⁴³⁷
V6 3.3L	VO-109	VA-418	VCA-1188	NS ⁴³⁷
Soul				
4 cyl. 1.6L	VO-106	VA-300	VCA-1179	NS ⁴³⁷
4 cyl. 2.0L	VO-148	VA-300	VCA-1179	NS ⁴³⁷
Soul EV				
-- Electric			VCA-1179	
Sportage				
4 cyl. 2.0L Turbo	VO-148	VA-458	VCA-1190	NS ⁴³⁷
4 cyl. 2.4L	VO-106	VA-458	VCA-1190	NS ⁴³⁷
Stinger				
4 cyl. 2.0L Turbo	VO-148		VCA-1062	NS ⁴³⁷
V6 3.3L Turbo			VCA-1062	NS ⁴³⁷
2017				
Cadenza				
V6 3.3L	VO-167		VCA-1181	NS ⁴³⁷

Se reporter à table de matière pour les notes en bas de page en français. Utilize el contenido para ver notas a pie.

NS - Non-Serviceable / Non réparable / No repairable LF - Life-Time Filter / Filtro para toda la vida / Filtre à vie

⁴³⁷ Requires replacement of the complete fuel pump/fuel filter module.



KIA (cont'd)

2017

Forte

4 cyl. 1.6L Turbo	VO-106		VCA-1051	NS ⁴³⁷
4 cyl. 2.0L	VO-148	VA-334	VCA-1051	NS ⁴³⁷

K900

V6 3.8	VO-99	VA-358		
V8 5.0	VO-99	VA-358		

Niro

4 cyl. 1.6L Hybrid	VO-106			NS ⁴³⁷
--------------------	--------	--	--	-------------------

Optima

4 cyl. 1.6L Turbo	VO-106		VCA-1192	
4 cyl 2.0L Turbo	VO-148		VCA-1192	NS ⁴³⁷
4 cyl. 2.0L Hybrid	VO-148	VA-417	VCA-1192	NS ⁴³⁷
4 cyl 2.4L	VO-106	VA-417	VCA-1192	NS ⁴³⁷

Rio

4 cyl. 1.6L	VO-106	VA-300	VCA-1047	NS ⁴³⁷
-------------	--------	--------	----------	-------------------

Rondo (Canada)

4 cyl 2.0L	VO-148	VA-283	VCA-1051	NS ⁴³⁷
------------	--------	--------	----------	-------------------

Sedona

V6 3.3L	VO-109	VA-418	VCA-1075	NS ⁴³⁷
---------	--------	--------	----------	-------------------

Sorento

4 cyl. 2.0L Turbo	VO-148	VA-418	VCA-1188	NS ⁴³⁷
4 cyl. 2.4L	VO-106	VA-418	VCA-1188	NS ⁴³⁷
V6 3.3L	VO-109	VA-418	VCA-1188	NS ⁴³⁷

Soul

4 cyl. 1.6L	VO-106	VA-300	VCA-1179	NS ⁴³⁷
4 cyl. 2.0L	VO-148	VA-300	VCA-1179	NS ⁴³⁷

Soul EV

-- Electric			VCA-1179	
-------------	--	--	----------	--

Sportage

4 cyl 2.0L Turbo	VO-148	VA-458	VCA-1190	NS ⁴³⁷
4 cyl 2.4L	VO-106	VA-458	VCA-1190	NS ⁴³⁷

2016

Cadenza

V6 3.3L	VO-109	VA-265	VCA-1075	NS ⁴³⁷
---------	--------	--------	----------	-------------------

Forte

4 cyl. 1.6L Turbo	VO-106		VCA-1051	NS ⁴³⁷
4 cyl. 1.8L	VO-148	VA-334	VCA-1051	NS ⁴³⁷
4 cyl. 2.0L	VO-148	VA-334	VCA-1051	NS ⁴³⁷

K900

V6 3.8	VO-99	VA-358		
V8 5.0	VO-99	VA-358		

Optima

4 cyl. 1.6L Turbo	VO-106		VCA-1192	
4 cyl 2.0L Turbo	VO-148		VCA-1192	NS ⁴³⁷
4 cyl 2.4L	VO-106	VA-417	VCA-1192	NS ⁴³⁷
4 cyl. 2.4L Hybrid	VO-106	VA-417	VCA-1192	NS ⁴³⁷

Rio

4 cyl. 1.6L	VO-106	VA-300	VCA-1047	NS ⁴³⁷
-------------	--------	--------	----------	-------------------

Rondo (Canada)

4 cyl 2.0L	VO-148	VA-283	VCA-1051	NS ⁴³⁷
------------	--------	--------	----------	-------------------

Sedona

V6 3.3L	VO-109	VA-418	VCA-1075	NS ⁴³⁷
---------	--------	--------	----------	-------------------

Se reporter à table de matière pour les notes en bas de page en français. Utilize el contenido para ver notas a pie.

NS - Non-Serviceable / Non réparable / No reparable LF - Life-Time Filter / Filtro para toda la vida / Filtre à vie

⁴³⁷ Requires replacement of the complete fuel pump/fuel filter module.



KIA (cont'd)

	Oil	Air	Cabin*	Fuel
2016				
Sorento				
4 cyl. 2.0L Turbo	VO-148	VA-418	VCA-1188	NS ⁴³⁷
4 cyl. 2.4L	VO-106	VA-418	VCA-1188	NS ⁴³⁷
V6 3.3L	VO-109	VA-418	VCA-1188	NS ⁴³⁷
Soul				
4 cyl. 1.6L	VO-106	VA-300	VCA-1179	NS ⁴³⁷
4 cyl. 2.0L	VO-148	VA-300	VCA-1179	NS ⁴³⁷
Soul EV				
-- Electric			VCA-1179	
Sportage				
4 cyl 2.0L FI Turbo	VO-148		VCA-1047	NS ⁴³⁷
4 cyl 2.4L	VO-106	VA-283	VCA-1047	NS ⁴³⁷
2015				
Cadenza				
V6 3.3L	VO-109	VA-265	VCA-1075	NS ⁴³⁷
Forte				
4 cyl. 1.6L Turbo	VO-106		VCA-1051	NS ⁴³⁷
4 cyl. 1.8L	VO-148	VA-334	VCA-1051	NS ⁴³⁷
4 cyl. 2.0L	VO-148	VA-334	VCA-1051	NS ⁴³⁷
K900				
V6 3.8	VO-99	VA-358		
V8 5.0	VO-99	VA-358		
Optima				
4 cyl 2.0L Turbo	VO-148	VA-265	VCA-1075	NS ⁴³⁷
4 cyl 2.4L	VO-106	VA-265	VCA-1075	NS ⁴³⁷
4 cyl. 2.4L Hybrid	VO-106	VA-265	VCA-1075	NS ⁴³⁷
Rio				
4 cyl. 1.6L	VO-106	VA-300	VCA-1047	NS ⁴³⁷
Rondo (Canada)				
4 cyl 2.0L	VO-148	VA-283	VCA-1051	NS ⁴³⁷
Sedona				
V6 3.3L	VO-109	VA-418	VCA-1075	NS ⁴³⁷
Sorento				
4 cyl. 2.4L	VO-106	VA-311	VCA-1071	NS ⁴³⁷
V6 3.3L	VO-109	VA-311	VCA-1071	NS ⁴³⁷
Soul				
4 cyl. 1.6L	VO-106	VA-300	VCA-1179	NS ⁴³⁷
4 cyl. 2.0L	VO-148	VA-300	VCA-1179	NS ⁴³⁷
Soul EV				
-- Electric			VCA-1179	
Sportage				
4 cyl 2.0L Turbo	VO-148		VCA-1047	NS ⁴³⁷
4 cyl 2.4L	VO-106	VA-283	VCA-1047	NS ⁴³⁷
2014				
Cadenza				
V6 3.3L	VO-109	VA-265	VCA-1075	NS ⁴³⁷
Forte				
4 cyl. 1.6L Turbo	VO-106		VCA-1051	NS ⁴³⁷
4 cyl. 1.8L	VO-148	VA-334	VCA-1051	NS ⁴³⁷
4 cyl. 2.0L	VO-148	VA-334	VCA-1051	NS ⁴³⁷
Optima				
4 cyl 2.0L Turbo	VO-148	VA-265	VCA-1075	NS ⁴³⁷

Se reporter à table de matière pour les notes en bas de page en français. Utilize el contenido para ver notas a pie.

NS - Non-Serviceable / Non réparable / No reparable LF - Life-Time Filter / Filtro para toda la vida / Filtre à vie

⁴³⁷ Requires replacement of the complete fuel pump/fuel filter module.



KIA (cont'd)

2014

Optima

4 cyl. 2.4L	VO-106	VA-265	VCA-1075	NS ⁴³⁷
4 cyl. 2.4L Hybrid	VO-106	VA-265	VCA-1075	NS ⁴³⁷

Rio

4 cyl. 1.6L	VO-106	VA-300	VCA-1047	NS ⁴³⁷
-------------	--------	--------	----------	-------------------

Rondo (Canada)

4 cyl 2.0L	VO-148	VA-283	VCA-1051	NS ⁴³⁷
------------	--------	--------	----------	-------------------

Sedona

V6 3.5L	VO-109	VA-230	VCA-1075	NS ⁴³⁷
---------	--------	--------	----------	-------------------

Sorento

4 cyl. 2.4L	VO-106	VA-311	VCA-1071	NS ⁴³⁷
V6 3.3L	VO-109	VA-311	VCA-1071	NS ⁴³⁷

Soul

4 cyl. 1.6L	VO-106	VA-300	VCA-1179	NS ⁴³⁷
4 cyl. 2.0L	VO-148	VA-300	VCA-1179	NS ⁴³⁷

Sportage

4 cyl 2.0L Turbo	VO-148		VCA-1047	NS ⁴³⁷
4 cyl 2.4L	VO-106	VA-283	VCA-1047	NS ⁴³⁷

2013

Forte

4 cyl. 2.0L	VO-148	VA-235	VCA-1047	NS ⁴³⁷
4 cyl. 2.4L	VO-106	VA-235	VCA-1047	NS ⁴³⁷

Optima

4 cyl 2.0L FI Turbo	VO-148	VA-265	VCA-1075	NS ⁴³⁷
4 cyl 2.4L	VO-106	VA-265	VCA-1075	NS ⁴³⁷
4 cyl. 2.4L Hybrid	VO-106	VA-265	VCA-1075	NS ⁴³⁷

Rio

4 cyl. 1.6L	VO-106	VA-300	VCA-1047	NS ⁴³⁷
-------------	--------	--------	----------	-------------------

Sorento

4 cyl. 2.4L	VO-106	VA-265	VCA-1071	NS ⁴³⁷
V6 3.5L	VO-109	VA-265	VCA-1071	NS ⁴³⁷

Soul

4 cyl. 1.6L	VO-106	VA-300	VCA-1115	NS ⁴³⁷
4 cyl. 2.0L	VO-148	VA-300	VCA-1115	NS ⁴³⁷

Sportage

4 cyl 2.0L Turbo	VO-148		VCA-1047	NS ⁴³⁷
4 cyl 2.4L	VO-106	VA-283	VCA-1047	NS ⁴³⁷

2012

Forte

4 cyl. 2.0L	VO-106	VA-235	VCA-1047	NS ⁴³⁷
4 cyl. 2.4L	VO-106	VA-235	VCA-1047	NS ⁴³⁷

Optima

4 cyl 2.0L Turbo	VO-106	VA-265	VCA-1075	NS ⁴³⁷
4 cyl 2.4L	VO-106	VA-265	VCA-1075	NS ⁴³⁷
4 cyl. 2.4L Hybrid	VO-106	VA-265	VCA-1075	NS ⁴³⁷

Rio

4 cyl. 1.6L	VO-106	VA-300	VCA-1047	NS ⁴³⁷
-------------	--------	--------	----------	-------------------

Rondo (Canada)

4 cyl 2.4L	VO-106	VA-243	VCA-1047	NS ⁴³⁷
V6 2.7L	VO-106	VA-243	VCA-1047	NS ⁴³⁷

Sedona

V6 3.5L	VO-109	VA-230	VCA-1075	NS ⁴³⁷
---------	--------	--------	----------	-------------------

Se reporter à table de matière pour les notes en bas de page en français. Utilize el contenido para ver notas a pie.

NS - Non-Serviceable / Non réparable / No reparable LF - Life-Time Filter / Filtro para toda la vida / Filtre à vie

⁴³⁷ Requires replacement of the complete fuel pump/fuel filter module.



KIA (cont'd)

	Oil	Air	Cabin*	Fuel
2012				
Sorento				
4 cyl. 2.4L	VO-106	VA-265	VCA-1071	NS ⁴³⁷
V6 3.5L	VO-109	VA-265	VCA-1071	NS ⁴³⁷
Soul				
4 cyl. 1.6L	VO-106	VA-300	VCA-1115	NS ⁴³⁷
4 cyl. 2.0L	VO-106	VA-300	VCA-1115	NS ⁴³⁷
Sportage				
4 cyl. 2.0L Turbo	VO-106		VCA-1047	NS ⁴³⁷
4 cyl. 2.4L FI	VO-106	VA-283	VCA-1047	NS ⁴³⁷
2011				
Borrego				
V6 3.8L FI (Canada)	VO-99	VA-384	VCA-1050	NS ⁴³⁷
V8 4.6L FI (Canada)	VO-99	VA-384	VCA-1050	NS ⁴³⁷
Forte				
4 cyl. 2.0L	VO-106	VA-235	VCA-1047	NS ⁴³⁷
4 cyl. 2.4L	VO-106	VA-235	VCA-1047	NS ⁴³⁷
Optima				
4 cyl. 2.0L Turbo	VO-106	VA-265	VCA-1075	NS ⁴³⁷
4 cyl. 2.4L	VO-106	VA-265	VCA-1075	NS ⁴³⁷
4 cyl. 2.4L Hybrid	VO-106	VA-265	VCA-1075	NS ⁴³⁷
Rio				
4 cyl. 1.6L	VO-106	VA-201	VCA-1047	NS ⁴³⁷
Rondo (Canada)				
4 cyl. 2.4L	VO-106	VA-243	VCA-1047	NS ⁴³⁷
V6 2.7L	VO-106	VA-243	VCA-1047	NS ⁴³⁷
Sedona				
V6 3.5L	VO-109	VA-230	VCA-1075	NS ⁴³⁷
Sorento				
4 cyl. 2.4L	VO-106	VA-265	VCA-1071	NS ⁴³⁷
V6 3.5L	VO-109	VA-265	VCA-1071	NS ⁴³⁷
Soul				
4 cyl. 1.6L	VO-106	VA-268	VCA-1115	NS ⁴³⁷
4 cyl. 2.0L	VO-106	VA-268	VCA-1115	NS ⁴³⁷
Sportage				
4 cyl. 2.0L Turbo	VO-106		VCA-1047	NS ⁴³⁷
4 cyl. 2.4L	VO-106	VA-283	VCA-1047	NS ⁴³⁷
2010				
Borrego				
V6 3.8L FI (Canada)	VO-99	VA-384	VCA-1050	NS ⁴³⁷
V8 4.6L FI (Canada)	VO-99	VA-384	VCA-1050	NS ⁴³⁷
Forte				
4 cyl. 2.0L	VO-106	VA-235	VCA-1047	NS ⁴³⁷
4 cyl. 2.4L	VO-106	VA-235	VCA-1047	NS ⁴³⁷
Magentis				
4 cyl. 2.4L FI (Canada)	VO-106	VA-243	VCA-1035 ^{X711} VCA-1072 ^{Z711}	NS ⁴³⁷
V6 2.7L FI (Canada)	VO-106	VA-243	VCA-1035 ^{X711} VCA-1072 ^{Z711}	NS ⁴³⁷
Optima				
4 cyl. 2.4L FI	VO-106	VA-243	VCA-1035 ^{X711} VCA-1072 ^{Z711}	NS ⁴³⁷
V6 2.7L FI	VO-106	VA-243	VCA-1035 ^{X711} VCA-1072 ^{Z711}	NS ⁴³⁷

Se reporter à table de matière pour les notes en bas de page en français. Utilize el contenido para ver notas a pie.

NS - Non-Serviceable / Non réparable / No reparable LF - Life-Time Filter / Filtro para toda la vida / Filtre à vie

⁴³⁷ Requires replacement of the complete fuel pump/fuel filter module. ^{X711}With Auto Temperature Control. ^{Z711}Without Auto Temperature Control.



KIA (cont'd)

2010

Rio

4 cyl. 1.6L	VO-106	VA-201	VCA-1047	NS ⁴³⁷
-------------	--------	--------	----------	-------------------

Rondo

4 cyl 2.4L	VO-106	VA-243	VCA-1047	NS ⁴³⁷
------------	--------	--------	----------	-------------------

V6 2.7L	VO-106	VA-243	VCA-1047	NS ⁴³⁷
---------	--------	--------	----------	-------------------

Sedona

V6 3.8L	VO-99	VA-230	VCA-1066	NS ⁴³⁷
---------	-------	--------	----------	-------------------

Soul

4 cyl. 1.6L	VO-106	VA-268	VCA-1115	NS ⁴³⁷
-------------	--------	--------	----------	-------------------

4 cyl. 2.0L	VO-106	VA-268	VCA-1115	NS ⁴³⁷
-------------	--------	--------	----------	-------------------

Sportage

4 cyl 2.0L	VO-106	VA-208	VCA-1047	NS ⁴³⁷
------------	--------	--------	----------	-------------------

V6 2.7L	VO-106	VA-208	VCA-1047	NS ⁴³⁷
---------	--------	--------	----------	-------------------

2009

Amanti

V6 3.8L FI	VO-90 ^{X427} VO-99 ^{Z427}			NS ⁴³⁷
------------	--	--	--	-------------------

Borrego

V6 3.8L FI	VO-99	VA-384	VCA-1050	NS ⁴³⁷
------------	-------	--------	----------	-------------------

V8 4.6L FI	VO-99	VA-384	VCA-1050	NS ⁴³⁷
------------	-------	--------	----------	-------------------

Magentis

4 cyl. 2.4L FI (Canada)	VO-106	VA-243	VCA-1035 ^{X711} VCA-1072 ^{Z711}	NS ⁴³⁷
-------------------------	--------	--------	--	-------------------

V6 2.7L FI (Canada)	VO-106	VA-243	VCA-1035 ^{X711} VCA-1072 ^{Z711}	NS ⁴³⁷
---------------------	--------	--------	--	-------------------

Optima

4 cyl 2.4L FI	VO-106	VA-243	VCA-1035 ^{X711} VCA-1072 ^{Z711}	NS ⁴³⁷
---------------	--------	--------	--	-------------------

V6 2.7L FI	VO-106	VA-243	VCA-1035 ^{X711} VCA-1072 ^{Z711}	NS ⁴³⁷
------------	--------	--------	--	-------------------

Rio

4 cyl. 1.6L FI	VO-106	VA-201	VCA-1047	NS ⁴³⁷
----------------	--------	--------	----------	-------------------

Rondo

4 cyl 2.4L FI	VO-106	VA-243	VCA-1047	NS ⁴³⁷
---------------	--------	--------	----------	-------------------

V6 2.7L FI	VO-106	VA-243	VCA-1047	NS ⁴³⁷
------------	--------	--------	----------	-------------------

Sedona

V6 3.8L FI	VO-90 ^{X427} VO-99 ^{Z427}	VA-230	VCA-1066	NS ⁴³⁷
------------	--	--------	----------	-------------------

Sorento

V6 3.3L FI	VO-90 ^{X427} VO-99 ^{Z427}	VA-247	VCA-1053	NS ⁴³⁷
------------	--	--------	----------	-------------------

V6 3.8L FI	VO-90 ^{X427} VO-99 ^{Z427}	VA-247	VCA-1053 ¹¹²	NS ⁴³⁷
------------	--	--------	-------------------------	-------------------

Spectra

4 cyl 2.0L FI	VO-106	VA-193	VCA-1050	NS ⁴³⁷
---------------	--------	--------	----------	-------------------

Sportage

4 cyl 2.0L FI	VO-106	VA-208	VCA-1047	NS ⁴³⁷
---------------	--------	--------	----------	-------------------

V6 2.7L FI	VO-106	VA-208	VCA-1047	NS ⁴³⁷
------------	--------	--------	----------	-------------------

2008

Amanti

V6 3.8L FI	VO-90			NS ⁴³⁷
------------	-------	--	--	-------------------

Se reporter à table de matière pour les notes en bas de page en français. Utilize el contenido para ver notas a pie.

NS - Non-Serviceable / Non réparable / No reparable LF - Life-Time Filter / Filtro para toda la vida / Filtre à vie

¹¹² Requires two (2). ⁴³⁷ Requires replacement of the complete fuel pump/fuel filter module. ^{X427}With filter height 5.1 inch. ^{X711}With Auto Temperature Control. ^{Z427}With filter height 4.2 inch. ^{Z711}Without Auto Temperature Control.



KIA (cont'd)

	Oil	Air	Cabin*	Fuel
2008				
Magentis				
4 cyl. 2.4L FI (Canada)	VO-106	VA-243	VCA-1035 ^{X711} VCA-1072 ^{Z711}	NS ⁴³⁷
V6 2.7L FI (Canada)	VO-106	VA-243	VCA-1035 ^{X711} VCA-1072 ^{Z711}	NS ⁴³⁷
Optima				
4 cyl. 2.4L FI	VO-106	VA-243	VCA-1035	NS ⁴³⁷
V6 2.7L FI	VO-106	VA-243	VCA-1035	NS ⁴³⁷
Rio				
4 cyl. 1.6L FI	VO-106	VA-201	VCA-1047	NS ⁴³⁷
Rondo				
4 cyl. 2.4L FI	VO-106	VA-243	VCA-1047	NS ⁴³⁷
V6 2.7L FI	VO-106	VA-243	VCA-1047	NS ⁴³⁷
Sedona				
V6 3.8L FI	VO-90 ^{X427} VO-99 ^{Z427}	VA-230	VCA-1066	NS ⁴³⁷
Sorento				
V6 3.3L FI	VO-90 ^{X421} VO-99 ^{Z421}	VA-247	VCA-1053 ¹¹²	NS ⁴³⁷
V6 3.8L FI	VO-90 ^{X421} VO-99 ^{Z421}	VA-247	VCA-1053 ¹¹²	NS ⁴³⁷
Spectra				
4 cyl. 2.0L FI	VO-106	VA-193	VCA-1050	NS ⁴³⁷
Sportage				
4 cyl. 2.0L FI	VO-106	VA-208	VCA-1047	NS ⁴³⁷
V6 2.7L FI	VO-106	VA-208	VCA-1047	NS ⁴³⁷
2007				
Amanti				
V6 3.8L FI	VO-90			NS ⁴³⁷
Magentis				
4 cyl. 2.4L FI (Canada)	VO-106	VA-243	VCA-1035 ^{X711} VCA-1072 ^{Z711}	NS ⁴³⁷
V6 2.7L FI (Canada)	VO-106	VA-243	VCA-1035 ^{X711} VCA-1072 ^{Z711}	NS ⁴³⁷
Optima				
4 cyl. 2.4L FI	VO-106	VA-243	VCA-1035 ^{X711} VCA-1072 ^{Z711}	NS ⁴³⁷
V6 2.7L FI	VO-106	VA-243	VCA-1035 ^{X711} VCA-1072 ^{Z711}	NS ⁴³⁷
Rio				
4 cyl. 1.6L FI	VO-106	VA-201	VCA-1047	NS ⁴³⁷
Rondo				
4 cyl. 2.4L FI	VO-106	VA-243	VCA-1047	NS ⁴³⁷
V6 2.7L FI	VO-106	VA-243	VCA-1047	NS ⁴³⁷
Sedona				
V6 3.8L FI	VO-90	VA-230	VCA-1066	NS ⁴³⁷
Sorento				
V6 3.8L FI	VO-90	VA-247	VCA-1053 ¹¹²	NS ⁴³⁷
Spectra				
4 cyl. 2.0L FI	VO-106	VA-193	VCA-1050	NS ⁴³⁷
Sportage				
4 cyl. 2.0L FI	VO-106	VA-208	VCA-1047	NS ⁴³⁷
V6 2.7L FI	VO-106	VA-208	VCA-1047	NS ⁴³⁷

Se reporter à table de matière pour les notes en bas de page en français. Utilize el contenido para ver notas a pie.

NS - Non-Serviceable / Non réparable / No reparable LF - Life-Time Filter / Filtro para toda la vida / Filtre à vie

¹¹² Requires two (2). ⁴³⁷ Requires replacement of the complete fuel pump/fuel filter module. ^{X421} Before 8/27/07. ^{X427} With filter height 5.1 inch. ^{X711} With Auto Temperature Control. ^{Z421} After 8/26/07. ^{Z427} With filter height 4.2 inch. ^{Z711} Without Auto Temperature Control.



KIA (cont'd)

2006

Amanti

V6 3.5L FI	VO-106	VA-345		NS ⁴³⁷
------------	--------	--------	--	-------------------

Magentis

4 cyl. 2.4L FI (Canada)	VO-106	VA-152	VCA-1035 ^{X711} VCA-1072 ^{Z711}	
V6 2.7L FI (Canada)	VO-106	VA-152	VCA-1035 ^{X711} VCA-1072 ^{Z711}	

Optima

4 cyl 2.4L (6) FI	VO-106	VA-152	VCA-1139 VCA-1035 ^{X711} VCA-1072 ^{Z711}	NS ⁴³⁷
4 cyl 2.4L (3) FI	VO-106	VA-243		
V6 2.7L (8) FI	VO-106	VA-152	VCA-1139	
V6 2.7L (4) FI	VO-106	VA-243	VCA-1035 ^{X711} VCA-1072 ^{Z711}	NS ⁴³⁷

Rio

4 cyl. 1.6L FI	VO-106	VA-201	VCA-1047	NS ⁴³⁷
----------------	--------	--------	----------	-------------------

Sedona

V6 3.8L FI	VO-90	VA-230	VCA-1066	NS ⁴³⁷
------------	-------	--------	----------	-------------------

Sorento

V6 3.5L FI	VO-106	VA-247	VCA-1053 ¹¹²	NS ⁴³⁷
------------	--------	--------	-------------------------	-------------------

Spectra

4 cyl 2.0L FI	VO-106	VA-193	VCA-1050	NS ⁴³⁷
---------------	--------	--------	----------	-------------------

Sportage

4 cyl 2.0L FI	VO-106	VA-208	VCA-1047	NS ⁴³⁷
V6 2.7L FI	VO-106	VA-208	VCA-1047	NS ⁴³⁷

2005

Amanti

V6 3.5L FI	VO-106	VA-345		NS ⁴³⁷
------------	--------	--------	--	-------------------

Magentis

4 cyl. 2.4L FI (Canada)	VO-106	VA-152		
V6 2.7L FI (Canada)	VO-106	VA-152		

Optima

4 cyl 2.4L FI	VO-106	VA-152	VCA-1139	
V6 2.7L FI	VO-106	VA-152	VCA-1139	

Rio

4 cyl. 1.6L FI	VO-106	VA-346		
----------------	--------	--------	--	--

Sedona

V6 3.5L FI	VO-106	VA-185		NS ⁴³⁷
------------	--------	--------	--	-------------------

Sorento

V6 3.5L FI	VO-106	VA-247	VCA-1053 ¹¹²	NS ⁴³⁷
------------	--------	--------	-------------------------	-------------------

Spectra

4 cyl 2.0L FI	VO-106	VA-193	VCA-1050	
---------------	--------	--------	----------	--

Sportage

4 cyl 2.0L FI	VO-106	VA-208	VCA-1047	NS ⁴³⁷
V6 2.7L FI	VO-106	VA-208	VCA-1047	NS ⁴³⁷

2004

Amanti

V6 3.5L FI	VO-106	VA-345		NS ⁴³⁷
------------	--------	--------	--	-------------------

Magentis

4 cyl. 2.4L FI (Canada)	VO-106	VA-152		
V6 2.7L FI (Canada)	VO-106	VA-152		

Se reporter à table de matière pour les notes en bas de page en français. Utilize el contenido para ver notas a pie.

NS - Non-Serviceable / Non réparable / No reparable LF - Life-Time Filter / Filtro para toda la vida / Filtre à vie

¹¹² Requires two (2). ⁴³⁷ Requires replacement of the complete fuel pump/fuel filter module. ^{X711}With Auto Temperature Control. ^{Z711}Without Auto Temperature Control.



KIA (cont'd)

	Oil	Air	Cabin*	Fuel
2004				
Optima				
4 cyl. 2.4L FI	VO-106	VA-152		
V6 2.7L FI	VO-106	VA-152		
Rio				
4 cyl. 1.6L FI	VO-106	VA-346		
Sedona				
V6 3.5L FI	VO-106	VA-185		NS ⁴³⁷
Sorento				
V6 3.5L FI	VO-106	VA-247	VCA-1053 ¹¹²	NS ⁴³⁷
Spectra				
4 cyl. 1.8L FI	VO-106	VA-178		
4 cyl. 2.0L FI	VO-106	VA-193		NS ⁴³⁷
2003				
Magentis				
4 cyl. 2.4L FI (Canada)	VO-106	VA-152		
V6 2.7L FI (Canada)	VO-106	VA-152		
Optima				
4 cyl. 2.4L FI	VO-106	VA-152		
V6 2.7L FI	VO-106	VA-152		
Rio				
4 cyl. 1.6L FI	VO-106	VA-346		
Sedona				
V6 3.5L FI	VO-106	VA-185		NS ⁴³⁷
Sorento				
V6 3.5L FI	VO-106	VA-247	VCA-1053 ¹¹²	NS ⁴³⁷
Spectra				
4 cyl. 1.8L FI	VO-106	VA-178		
2002				
Magentis				
4 cyl. 2.4L FI (Canada)	VO-106	VA-152		
V6 2.7L FI (Canada)	VO-106	VA-152		
Optima				
4 cyl. 2.4L FI	VO-106	VA-152		
V6 2.7L FI	VO-106	VA-152		
Rio				
4 cyl. 1.5L FI	VO-106	VA-346		
Sedona				
V6 3.5L FI	VO-106	VA-185		NS ⁴³⁷
Spectra				
4 cyl. 1.8L FI	VO-106	VA-178		
Sportage				
4 cyl. 2.0L FI	VO-106	VA-147		
2001				
Magentis				
4 cyl. 2.4L FI (Canada)	VO-106	VA-152		
V6 2.5L FI (Canada)	VO-106	VA-152		
Optima				
4 cyl. 2.4L FI	VO-106	VA-152		
V6 2.5L FI	VO-106	VA-152		
Rio				
4 cyl. 1.5L FI	VO-106	VA-346		

Se reporter à table de matière pour les notes en bas de page en français. Utilize el contenido para ver notas a pie.

NS - Non-Serviceable / Non réparable / No repairable LF - Life-Time Filter / Filtro para toda la vida / Filtre à vie

¹¹² Requires two (2). ⁴³⁷ Requires replacement of the complete fuel pump/fuel filter module.



KIA (cont'd)

2001

Sephia

4 cyl. 1.8L FI	VO-106	VA-178		
----------------	--------	--------	--	--

Spectra

4 cyl. 1.8L FI	VO-106	VA-178		
----------------	--------	--------	--	--

Sportage

4 cyl. 2.0L FI	VO-106	VA-147		
----------------	--------	--------	--	--

2000

Sephia

4 cyl. 1.8L FI	VO-106	VA-178		
----------------	--------	--------	--	--

Spectra

4 cyl. 1.8L FI	VO-106	VA-178		
----------------	--------	--------	--	--

Sportage

4 cyl. 2.0L FI	VO-106	VA-147		
----------------	--------	--------	--	--

1999

Sephia

4 cyl. 1.8L FI	VO-106	VA-178		
----------------	--------	--------	--	--

Sportage

4 cyl. 2.0L FI	VO-106	VA-147		
----------------	--------	--------	--	--

1998

Sephia

4 cyl. 1.8L FI	VO-106	VA-178		
----------------	--------	--------	--	--

Sportage

4 cyl. 2.0L FI	VO-106	VA-147		
----------------	--------	--------	--	--

1997

Sephia

4 cyl. 1.6L FI	VO-106			
----------------	--------	--	--	--

4 cyl. 1.8L FI	VO-106			
----------------	--------	--	--	--

Sportage

4 cyl. 2.0L FI	VO-106	VA-147		
----------------	--------	--------	--	--

1996

Sephia

4 cyl. 1.6L FI	VO-106			
----------------	--------	--	--	--

4 cyl. 1.8L FI	VO-106			
----------------	--------	--	--	--

Sportage

4 cyl. 2.0L FI	VO-106	VA-147		
----------------	--------	--------	--	--

1995

Sephia

4 cyl. 1.6L FI	VO-106			
----------------	--------	--	--	--

4 cyl. 1.8L FI	VO-106			
----------------	--------	--	--	--

Sportage

4 cyl. 2.0L FI	VO-106	VA-147		
----------------	--------	--------	--	--

LAND ROVER

2019

Discovery

V6 3.0L Diesel Turbo		VA-446	VCA-1031	
----------------------	--	--------	----------	--

V6 3.0L Supercharged	VO-141	VA-446	VCA-1031	NS ⁴³⁷
----------------------	--------	--------	----------	-------------------

Discovery Sport

4 cyl. 2.0 Turbo			VCA-1158 ^{X344}	NS ⁴³⁷
------------------	--	--	--------------------------	-------------------

			VCA-1108 ^{Z344}	
--	--	--	--------------------------	--

Range Rover

V6 3.0L Diesel Turbo		VA-446	VCA-1031	
----------------------	--	--------	----------	--

Se reporter à table de matière pour les notes en bas de page en français. Utilize el contenido para ver notas a pie.

NS - Non-Serviceable / Non réparable / No reparable LF - Life-Time Filter / Filtro para toda la vida / Filtre à vie

⁴³⁷ Requires replacement of the complete fuel pump/fuel filter module. ^{X344}Dust filter. ^{Z344}Dust and odor filter.



LAND ROVER (cont'd)

	Oil	Air	Cabin*	Fuel
2019				
Range Rover				
V6 3.0L Supercharged	VO-141	VA-446 ¹¹²	VCA-1031	NS ⁴³⁷
V8 5.0L Supercharged	VO-141	VA-446 ¹¹²	VCA-1031	NS ⁴³⁷
Range Rover Evoque				
4 cyl. 2.0L Turbo			VCA-1158 ^{X344} VCA-1108 ^{Z344}	NS ⁴³⁷
Range Rover Sport				
V6 3.0L Diesel Turbo		VA-446		
V6 3.0L Supercharged	VO-141	VA-446 ¹¹²	VCA-1031	NS ⁴³⁷
V8 5.0L Supercharged	VO-141	VA-446 ¹¹²	VCA-1031	NS ⁴³⁷
Range Rover Velar				
4 cyl. 2.0L Diesel			VCA-1031	
4 cyl. 2.0L GAS			VCA-1031	
V6 3.0L Supercharged	VO-141		VCA-1031	
2018				
Discovery				
V6 3.0L Diesel Turbo		VA-446	VCA-1031	
V6 3.0L Supercharged	VO-141	VA-446	VCA-1031	NS ⁴³⁷
Discovery Sport				
4 cyl. 2.0 Turbo			VCA-1158 ^{X344} VCA-1108 ^{Z344}	NS ⁴³⁷
Range Rover				
V6 3.0L Diesel Turbo		VA-446	VCA-1031	
V6 3.0L Supercharged	VO-141	VA-446 ¹¹²	VCA-1031	NS ⁴³⁷
V8 5.0L Supercharged	VO-141	VA-446 ¹¹²	VCA-1031	NS ⁴³⁷
Range Rover Evoque				
4 cyl. 2.0L Turbo			VCA-1158 ^{X344} VCA-1108 ^{Z344}	NS ⁴³⁷
Range Rover Sport				
V6 3.0L Diesel Turbo		VA-446		
V6 3.0L Supercharged	VO-141	VA-446 ¹¹²	VCA-1031	NS ⁴³⁷
V8 5.0L Supercharged	VO-141	VA-446 ¹¹²	VCA-1031	NS ⁴³⁷
Range Rover Velar				
4 cyl. 2.0L Diesel			VCA-1031	
4 cyl. 2.0L GAS			VCA-1031	
V6 3.0L Supercharged	VO-141		VCA-1031	
2017				
Discovery				
V6 3.0L Diesel Turbo		VA-446	VCA-1031	
V6 3.0L Supercharged	VO-141	VA-446	VCA-1031	NS ⁴³⁷
Discovery Sport				
4 cyl. 2.0 Turbo	VO-25		VCA-1158 ^{X344} VCA-1108 ^{Z344}	NS ⁴³⁷
Range Rover				
V6 3.0L Diesel Turbo		VA-446	VCA-1031	
V6 3.0L Supercharged	VO-141	VA-446 ¹¹²	VCA-1031	NS ⁴³⁷
V8 5.0L Supercharged	VO-141	VA-446 ¹¹²	VCA-1031	NS ⁴³⁷
Range Rover Evoque				
4 cyl. 2.0L Turbo	VO-25		VCA-1158 ^{X344} VCA-1108 ^{Z344}	NS ⁴³⁷
Range Rover Sport				
V6 3.0L Diesel Turbo		VA-446		
V6 3.0L Supercharged	VO-141	VA-446 ¹¹²	VCA-1031	NS ⁴³⁷

Se reporter à table de matière pour les notes en bas de page en français. Utilize el contenido para ver notas a pie.

NS - Non-Serviceable / Non réparable / No reparable LF - Life-Time Filter / Filtro para toda la vida / Filtre à vie

¹¹² Requires two (2). ⁴³⁷ Requires replacement of the complete fuel pump/fuel filter module. ^{X344}Dust filter. ^{Z344}Dust and odor filter.



LAND ROVER (cont'd)

2017

Range Rover Sport

V8 5.0L Supercharged	VO-141	VA-446 ¹¹²	VCA-1031	NS ⁴³⁷
----------------------	--------	-----------------------	----------	-------------------

2016

Discovery Sport

4 cyl. 2.0 Turbo	VO-25		VCA-1158 ^{X344} VCA-1108 ^{Z344}	NS ⁴³⁷
------------------	-------	--	--	-------------------

LR4

V6 3.0L	VO-141	VA-446		NS ⁴³⁷
---------	--------	--------	--	-------------------

Range Rover

V6 3.0L Diesel Turbo		VA-446	VCA-1031	
V6 3.0L Supercharged	VO-141	VA-446 ¹¹²	VCA-1031	NS ⁴³⁷
V8 5.0L Supercharged	VO-141	VA-446 ¹¹²	VCA-1031	NS ⁴³⁷

Range Rover Evoque

4 cyl. 2.0L Turbo	VO-25		VCA-1158 ^{X344} VCA-1108 ^{Z344}	NS ⁴³⁷
-------------------	-------	--	--	-------------------

Range Rover Sport

V6 3.0L Diesel Turbo		VA-446		
V6 3.0L Supercharged	VO-141	VA-446 ¹¹²		NS ⁴³⁷
V8 5.0L Supercharged	VO-141	VA-446 ¹¹²		NS ⁴³⁷

2015

Discovery Sport

4 cyl. 2.0 Turbo	VO-25		VCA-1158 ^{X344} VCA-1108 ^{Z344}	NS ⁴³⁷
------------------	-------	--	--	-------------------

LR2

4 cyl. 2.0L Turbo	VO-25		VCA-1158 ^{X344} VCA-1108 ^{Z344}	NS ⁴³⁷
-------------------	-------	--	--	-------------------

LR4

V6 3.0L	VO-141	VA-446		NS ⁴³⁷
---------	--------	--------	--	-------------------

Range Rover

V6 3.0L Supercharged	VO-141	VA-446 ¹¹²	VCA-1031	NS ⁴³⁷
V8 5.0L Supercharged	VO-141	VA-446 ¹¹²	VCA-1031	NS ⁴³⁷

Range Rover Evoque

4 cyl. 2.0L Turbo	VO-25		VCA-1158 ^{X344} VCA-1108 ^{Z344}	NS ⁴³⁷
-------------------	-------	--	--	-------------------

Range Rover Sport

V6 3.0L Supercharged	VO-141	VA-446 ¹¹²		NS ⁴³⁷
V8 5.0L Supercharged	VO-141	VA-446 ¹¹²		NS ⁴³⁷

2014

LR2

4 cyl. 2.0L Turbo	VO-25		VCA-1158 ^{X344} VCA-1108 ^{Z344}	NS ⁴³⁷
-------------------	-------	--	--	-------------------

LR4

V6 3.0L	VO-141	VA-446		NS ⁴³⁷
---------	--------	--------	--	-------------------

Range Rover

V6 3.0L Supercharged	VO-141	VA-446 ¹¹²	VCA-1031	NS ⁴³⁷
V8 5.0L Supercharged	VO-141	VA-446 ¹¹²	VCA-1031	NS ⁴³⁷

Range Rover Evoque

4 cyl. 2.0L Turbo	VO-25		VCA-1158 ^{X344} VCA-1108 ^{Z344}	NS ⁴³⁷
-------------------	-------	--	--	-------------------

Range Rover Sport

V6 3.0L Supercharged	VO-141	VA-446 ¹¹²		NS ⁴³⁷
V8 5.0L Supercharged	VO-141	VA-446 ¹¹²		NS ⁴³⁷

Se reporter à table de matière pour les notes en bas de page en français. Utilize el contenido para ver notas a pie.

NS - Non-Serviceable / Non réparable / No reparable LF - Life-Time Filter / Filtro para toda la vida / Filtre à vie

¹¹² Requires two (2). ⁴³⁷ Requires replacement of the complete fuel pump/fuel filter module. ^{X344}Dust filter. ^{Z344}Dust and odor filter.



LAND ROVER (cont'd)

	Oil	Air	Cabin*	Fuel
2013				
LR2				
4 cyl. 2.0L Turbo	VO-25		VCA-1158 ^{X344} VCA-1108 ^{Z344}	NS ⁴³⁷
LR4				
V8 5.0L	VO-141	VA-446		NS ⁴³⁷
Range Rover				
V8 5.0L	VO-141	VA-446 ¹¹²	VCA-1156	NS ⁴³⁷
V8 5.0L Supercharged	VO-141	VA-446 ¹¹²	VCA-1156	NS ⁴³⁷
Range Rover Evoque				
4 cyl. 2.0L Turbo	VO-25		VCA-1158 ^{X344} VCA-1108 ^{Z344}	NS ⁴³⁷
Range Rover Sport				
V8 5.0L	VO-141	VA-446 ¹¹²		NS ⁴³⁷
V8 5.0L Supercharged	VO-141	VA-446 ¹¹²		NS ⁴³⁷
2012				
LR2				
6 cyl 3.2L	VO-97		VCA-1158 ^{X344} VCA-1108 ^{Z344}	NS ⁴³⁷
LR4				
V8 5.0L	VO-141	VA-446		NS ⁴³⁷
Range Rover				
V8 5.0L	VO-141	VA-446 ¹¹²	VCA-1156	NS ⁴³⁷
V8 5.0L Supercharged	VO-141	VA-446 ¹¹²	VCA-1156	NS ⁴³⁷
Range Rover Evoque				
4 cyl. 2.0L Turbo	VO-25		VCA-1158 ^{X344} VCA-1108 ^{Z344}	NS ⁴³⁷
Range Rover Sport				
V8 5.0L	VO-141	VA-446 ¹¹²		NS ⁴³⁷
V8 5.0L Supercharged	VO-141	VA-446 ¹¹²		NS ⁴³⁷
2011				
LR2				
6 cyl 3.2L	VO-97		VCA-1158 ^{X344} VCA-1108 ^{Z344}	NS ⁴³⁷
LR4				
V8 5.0L	VO-141	VA-446		NS ⁴³⁷
Range Rover				
V8 5.0L	VO-141	VA-446 ¹¹²	VCA-1156	NS ⁴³⁷
V8 5.0L Supercharged	VO-141	VA-446 ¹¹²	VCA-1156	NS ⁴³⁷
Range Rover Sport				
V8 5.0L	VO-141	VA-446 ¹¹²		NS ⁴³⁷
V8 5.0L Supercharged	VO-141	VA-446 ¹¹²		NS ⁴³⁷
2010				
LR2				
6 cyl 3.2L	VO-97		VCA-1158 ^{X344} VCA-1108 ^{Z344}	NS ⁴³⁷
LR4				
V8 5.0L	VO-141	VA-446		NS ⁴³⁷
Range Rover				
V8 5.0L	VO-141	VA-446 ¹¹²	VCA-1156	NS ⁴³⁷
V8 5.0L Supercharged	VO-141	VA-446 ¹¹²	VCA-1156	NS ⁴³⁷
Range Rover Sport				
V8 5.0L	VO-141	VA-446 ¹¹²		NS ⁴³⁷

Se reporter à table de matière pour les notes en bas de page en français. Utilize el contenido para ver notas a pie.

NS - Non-Serviceable / Non réparable / No repairable LF - Life-Time Filter / Filtro para toda la vida / Filtre à vie

¹¹² Requires two (2). ⁴³⁷ Requires replacement of the complete fuel pump/fuel filter module. ^{X344}Dust filter. ^{Z344}Dust and odor filter.



LAND ROVER (cont'd)

2010

Range Rover Sport

V8 5.0L Supercharged	VO-141	VA-446 ¹¹²		NS ⁴³⁷
----------------------	--------	-----------------------	--	-------------------

2009

LR2

6 cyl 3.2L FI	VO-97		VCA-1158 ^{X344} VCA-1108 ^{Z344}	NS ⁴³⁷
---------------	-------	--	--	-------------------

LR3

V6 4.0L (4) FI	VO-88			NS ⁴³⁷
V8 4.4L (5) FI	VO-86			NS ⁴³⁷

Range Rover

V8 4.2L (3) FI (S.C.)	VO-86		VCA-1156	NS ⁴³⁷
V8 4.4L (5) FI	VO-86		VCA-1156	NS ⁴³⁷

Range Rover Sport

V8 4.2L (3) FI (S.C.)	VO-86			NS ⁴³⁷
V8 4.4L (5) FI	VO-86			NS ⁴³⁷

2008

LR2

6 cyl 3.2L FI	VO-97		VCA-1158 ^{X344} VCA-1108 ^{Z344}	NS ⁴³⁷
---------------	-------	--	--	-------------------

LR3

V6 4.0L (4) FI	VO-88			NS ⁴³⁷
V8 4.4L (5) FI	VO-86			NS ⁴³⁷

Range Rover

V8 4.2L (3) FI (S.C.)	VO-86		VCA-1156	NS ⁴³⁷
V8 4.4L (5) FI	VO-86		VCA-1156	NS ⁴³⁷

Range Rover Sport

V8 4.2L (3) FI (S.C.)	VO-86			NS ⁴³⁷
V8 4.4L (5) FI	VO-86			NS ⁴³⁷

2007

LR3

V6 4.0L (4) FI	VO-88			NS ⁴³⁷
V8 4.4L (5) FI	VO-86			NS ⁴³⁷

Range Rover

V8 4.2L (3) FI (S.C.)	VO-86		VCA-1156	NS ⁴³⁷
V8 4.4L (5) FI	VO-86		VCA-1156	NS ⁴³⁷

Range Rover Sport

V8 4.2L (3) FI (S.C.)	VO-86			NS ⁴³⁷
V8 4.4L (5) FI	VO-86			NS ⁴³⁷

2006

LR3

V6 4.0L (4) FI	VO-88			NS ⁴³⁷
V8 4.4L (5) FI	VO-86			NS ⁴³⁷

Range Rover

V8 4.2L (3) FI (S.C.)	VO-86		VCA-1156	NS ⁴³⁷
V8 4.4L (5) FI	VO-86		VCA-1156	NS ⁴³⁷

Range Rover Sport

V8 4.2L (3) FI (S.C.)	VO-86			NS ⁴³⁷
V8 4.4L (5) FI	VO-86			NS ⁴³⁷

2005

Freelander

V6 2.5L FI	VO-124	VA-347		
------------	--------	--------	--	--

Se reporter à table de matière pour les notes en bas de page en français. Utilize el contenido para ver notas a pie.

NS - Non-Serviceable / Non réparable / No repairable LF - Life-Time Filter / Filtro para toda la vida / Filtre à vie

¹¹² Requires two (2). ⁴³⁷ Requires replacement of the complete fuel pump/fuel filter module. ^{X344}Dust filter. ^{Z344}Dust and odor filter.



LAND ROVER (cont'd)

	Oil	Air	Cabin*	Fuel
2005				
LR3				
V6 4.0L FI	VO-88			NS ⁴³⁷
V8 4.4L FI	VO-86			NS ⁴³⁷
Range Rover				
V8 4.4L FI	VO-74		VCA-1156	
2004				
Discovery				
V8 4.6L FI	VO-95	VA-347		VG-14
Freelander				
V6 2.5L FI	VO-124	VA-347		
Range Rover				
V8 4.4L FI	VO-74		VCA-1156	
2003				
Discovery				
V8 4.6L FI	VO-95	VA-347		VG-14
Freelander				
V6 2.5L FI	VO-124	VA-347		
Range Rover				
V8 4.4L FI	VO-74		VCA-1156	
2002				
Discovery				
V8 4.0L FI	VO-95	VA-347		VG-14
Freelander				
V6 2.5L FI	VO-124	VA-347		
Range Rover				
V8 4.6L FI	VO-95	VA-347		VG-14
2001				
Discovery				
V8 4.0L FI	VO-95	VA-347		VG-14
Range Rover				
V8 4.6L FI	VO-95	VA-347		VG-14
2000				
Discovery				
V8 4.0L FI	VO-95	VA-347		VG-14
Range Rover				
V8 4.0L FI	VO-95	VA-347		VG-14
V8 4.6L FI	VO-95	VA-347		VG-14
1999				
Discovery Series II				
V8 4.0L FI	VO-95	VA-347		VG-14
Discovery Series I				
V8 4.0L FI	VO-95			VG-14
Range Rover				
V8 4.0L FI	VO-95	VA-347		VG-14
V8 4.6L FI	VO-95	VA-347		VG-14
1998				
Discovery				
V8 4.0L FI	VO-95			VG-14
Range Rover				
V8 4.0L (2) FI	VO-95	VA-347		VG-14
V8 4.6L (4) FI	VO-95	VA-347		VG-14

Se reporter à table de matière pour les notes en bas de page en français. Utilize el contenido para ver notas a pie.

NS - Non-Serviceable / Non réparable / No repairable LF - Life-Time Filter / Filtro para toda la vida / Filtre à vie

⁴³⁷ Requires replacement of the complete fuel pump/fuel filter module.



LAND ROVER (cont'd)

1997

Defender 90

V8 4.0L FI	VO-95			VG-14
------------	-------	--	--	-------

Discovery

V8 4.0L FI	VO-95			VG-14
------------	-------	--	--	-------

Range Rover

V8 4.0L (2) FI	VO-95			VG-14
----------------	-------	--	--	-------

V8 4.6L (4) FI	VO-95			VG-14
----------------	-------	--	--	-------

1996

Discovery

V8 4.0L FI	VO-95			VG-14
------------	-------	--	--	-------

Range Rover

V8 4.0L (2) FI	VO-95			VG-14
----------------	-------	--	--	-------

V8 4.6L (4) FI	VO-95			VG-14
----------------	-------	--	--	-------

1995

Defender 90

V8 3.9L FI	VO-95 ^{X504} VO-25 ^{Z504}			VG-14
------------	--	--	--	-------

Discovery

V8 3.9L FI	VO-95			VG-14
------------	-------	--	--	-------

Range Rover

V8 3.9L FI	VO-95 ^{X504} VO-25 ^{Z504}			VG-14
------------	--	--	--	-------

V8 4.0L FI	VO-95			VG-14
------------	-------	--	--	-------

V8 4.2L FI	VO-95 ^{X504} VO-25 ^{Z504}			VG-14
------------	--	--	--	-------

1994

Defender 90

V8 3.9L FI	VO-95 ^{X504} VO-25 ^{Z504}			VG-14
------------	--	--	--	-------

Discovery

V8 3.9L FI	VO-95			VG-14
------------	-------	--	--	-------

Range Rover

V8 3.9L FI	VO-95 ^{X504} VO-25 ^{Z504}			VG-14
------------	--	--	--	-------

V8 4.2L FI	VO-95 ^{X504} VO-25 ^{Z504}			VG-14
------------	--	--	--	-------

1993

Range Rover

V8 3.9L FI	VO-95 ^{X504} VO-25 ^{Z504}			VG-14
------------	--	--	--	-------

V8 4.2L FI	VO-95 ^{X504} VO-25 ^{Z504}			VG-14
------------	--	--	--	-------

LEXUS

2019

ES300H

L4 2.5L Hybrid	VO-175	VA-500	VCA-2035	NS ⁴³⁷
----------------	--------	--------	----------	-------------------

ES350

V6 3.5L	VO-84	VA-273	VCA-2035	NS ⁴³⁷
---------	-------	--------	----------	-------------------

GS300

4 cyl. 2.0 Turbo	VO-84	VA-445	VCA-1122	NS ⁴³⁷
------------------	-------	--------	----------	-------------------

GS350

V6 3.5L	VO-87	VA-445	VCA-1122	NS ⁴³⁷
---------	-------	--------	----------	-------------------

Se reporter à table de matière pour les notes en bas de page en français. Utilize el contenido para ver notas a pie.

NS - Non-Serviceable / Non réparable / No reparable LF - Life-Time Filter / Filtro para toda la vida / Filtre à vie

⁴³⁷ Requires replacement of the complete fuel pump/fuel filter module. ^{X504}Alternate ^{Z504}Primary



LEXUS (cont'd)

	Oil	Air	Cabin*	Fuel
2019				
GS450h				
V6 3.5L Hybrid	VO-87	VA-445	VCA-1122	NS ⁴³⁷
GS F				
V8 5.0L	VO-96		VCA-1122	NS ⁴³⁷
GX460				
V8 4.6L	VO-87	VA-256	VCA-1031	NS ⁴³⁷
IS300				
4 cyl. 2.0L Turbo	VO-84	VA-445	VCA-1122	NS ⁴³⁷
V6 3.5L	VO-87	VA-445	VCA-1122	NS ⁴³⁷
IS350				
V6 3.5L	VO-87	VA-445	VCA-1122	NS ⁴³⁷
LC500h				
V6 3.5L	VO-84			NS ⁴³⁷
LC500				
V8 5.0	VO-96			NS ⁴³⁷
LS500h				
V6 3.5L	VO-84			NS ⁴³⁷
LS500				
V6 3.5L Turbo	VO-40			NS ⁴³⁷
LX570				
V8 5.7L	VO-96	VA-234	VCA-1031	NS ⁴³⁷
NX300				
4 cyl. 2.0 Turbo	VO-84	VA-273	VCA-1031	NS ⁴³⁷
NX300h				
4 cyl. 2.5 Hybrid	VO-84	VA-257	VCA-1031	NS ⁴³⁷
RC F				
V8 5.0	VO-96		VCA-1122	NS ⁴³⁷
RC300				
4 cyl. 2.0L Turbo	VO-84	VA-445	VCA-1122	NS ⁴³⁷
V6 3.5	VO-87	VA-445	VCA-1122	NS ⁴³⁷
RC350				
V6 3.5	VO-87	VA-445	VCA-1122	NS ⁴³⁷
RX350				
V6 3.5L	VO-84	VA-273	VCA-2035	NS ⁴³⁷
RX450h				
V6 3.5L Hybrid	VO-84		VCA-2035	NS ⁴³⁷
UX200				
4 cyl. 2.0L 121	VO-175	VA-500	VCA-2035	NS ⁴³⁷
UX250h				
4 cyl. 2.0L 121 Hybrid	VO-175		VCA-2035	NS ⁴³⁷
2018				
ES300H				
L4 2.5L Hybrid	VO-84	VA-309	VCA-1031	NS ⁴³⁷
ES350				
V6 3.5L	VO-84	VA-273	VCA-1031	NS ⁴³⁷
GS300				
4 cyl. 2.0 Turbo	VO-84	VA-445	VCA-1122	NS ⁴³⁷
GS350				
V6 3.5L	VO-87	VA-445	VCA-1122	NS ⁴³⁷
GS450h				
V6 3.5L Hybrid	VO-87	VA-445	VCA-1122	NS ⁴³⁷

Se reporter à table de matière pour les notes en bas de page en français. Utilize el contenido para ver notas a pie.

NS - Non-Serviceable / Non réparable / No reparable LF - Life-Time Filter / Filtro para toda la vida / Filtre à vie

⁴³⁷ Requires replacement of the complete fuel pump/fuel filter module.



LEXUS (cont'd)

2018

GS F

V8 5.0L	VO-96		VCA-1122	NS ⁴³⁷
---------	-------	--	----------	-------------------

GX460

V8 4.6L	VO-87	VA-256	VCA-1031	NS ⁴³⁷
---------	-------	--------	----------	-------------------

IS300

4 cyl. 2.0L Turbo	VO-84	VA-445	VCA-1122	NS ⁴³⁷
-------------------	-------	--------	----------	-------------------

V6 3.5L	VO-87	VA-445	VCA-1122	NS ⁴³⁷
---------	-------	--------	----------	-------------------

IS350

V6 3.5L	VO-87	VA-445	VCA-1122	NS ⁴³⁷
---------	-------	--------	----------	-------------------

LC500h

V6 3.5L	VO-84			NS ⁴³⁷
---------	-------	--	--	-------------------

LC500

V8 5.0	VO-96			NS ⁴³⁷
--------	-------	--	--	-------------------

LS500h

V6 3.5L	VO-84			NS ⁴³⁷
---------	-------	--	--	-------------------

LS500

V6 3.5L Turbo	VO-40			NS ⁴³⁷
---------------	-------	--	--	-------------------

LX570

V8 5.7L	VO-96	VA-234	VCA-1031	NS ⁴³⁷
---------	-------	--------	----------	-------------------

NX300

4 cyl. 2.0 Turbo	VO-84	VA-273	VCA-1031	NS ⁴³⁷
------------------	-------	--------	----------	-------------------

NX300h

4 cyl. 2.5 Hybrid	VO-84	VA-257	VCA-1031	NS ⁴³⁷
-------------------	-------	--------	----------	-------------------

RC F

V8 5.0	VO-96		VCA-1122	NS ⁴³⁷
--------	-------	--	----------	-------------------

RC300

4 cyl. 2.0L Turbo	VO-84	VA-445	VCA-1122	NS ⁴³⁷
-------------------	-------	--------	----------	-------------------

V6 3.5	VO-87	VA-445	VCA-1122	NS ⁴³⁷
--------	-------	--------	----------	-------------------

RC350

V6 3.5	VO-87	VA-445	VCA-1122	NS ⁴³⁷
--------	-------	--------	----------	-------------------

RX350

V6 3.5L	VO-84	VA-273	VCA-2035	NS ⁴³⁷
---------	-------	--------	----------	-------------------

RX450h

V6 3.5L Hybrid	VO-84		VCA-2035	NS ⁴³⁷
----------------	-------	--	----------	-------------------

2017

CT200h

4 cyl. 1.8L FI (Hybrid)	VO-102	VA-257	VCA-1031	NS ⁴³⁷
-------------------------	--------	--------	----------	-------------------

ES300H

L4 2.5L (Hybrid)	VO-84	VA-309	VCA-1031	NS ⁴³⁷
------------------	-------	--------	----------	-------------------

ES350

V6 3.5L	VO-84	VA-273	VCA-1031	NS ⁴³⁷
---------	-------	--------	----------	-------------------

GS350

V6 3.5L	VO-87	VA-445	VCA-1122	NS ⁴³⁷
---------	-------	--------	----------	-------------------

GS450h

V6 3.5L Hybrid	VO-87	VA-445	VCA-1122	NS ⁴³⁷
----------------	-------	--------	----------	-------------------

GS F

V8 5.0L	VO-96		VCA-1122	NS ⁴³⁷
---------	-------	--	----------	-------------------

GS Turbo

4 cyl. 2.0 Turbo	VO-84	VA-445	VCA-1122	NS ⁴³⁷
------------------	-------	--------	----------	-------------------

GX460

V8 4.6L	VO-87	VA-256	VCA-1031	NS ⁴³⁷
---------	-------	--------	----------	-------------------

Se reporter à table de matière pour les notes en bas de page en français. Utilize el contenido para ver notas a pie.

NS - Non-Serviceable / Non réparable / No reparable LF - Life-Time Filter / Filtro para toda la vida / Filtre à vie

⁴³⁷ Requires replacement of the complete fuel pump/fuel filter module.



LEXUS (cont'd)

	Oil	Air	Cabin*	Fuel
2017				
IS300				
V6 3.5L FI (2GRFSE)	VO-87	VA-445	VCA-1122	NS ⁴³⁷
IS350				
V6 3.5L	VO-87	VA-445	VCA-1122	NS ⁴³⁷
IS Turbo				
4 cyl. 2.0L Turbo	VO-84	VA-445	VCA-1122	NS ⁴³⁷
LS460				
V8 4.6L FI (1URFSE)	VO-87	VA-309 ¹¹²	VCA-1031	NS ⁴³⁷
LX570				
V8 5.7L	VO-96	VA-234	VCA-1031	NS ⁴³⁷
NX200t				
4 cyl. 2.0 Turbo	VO-84	VA-273	VCA-1031	NS ⁴³⁷
NX300h				
4 cyl. 2.5 Hybrid	VO-84	VA-257	VCA-1031	NS ⁴³⁷
RC F				
V8 5.0	VO-96		VCA-1122	NS ⁴³⁷
RC300				
V6 3.5 FI	VO-87	VA-445	VCA-1122	NS ⁴³⁷
RC350				
V6 3.5	VO-87	VA-445	VCA-1122	NS ⁴³⁷
RC Turbo				
4 cyl. 2.0L Turbo	VO-84	VA-445	VCA-1122	NS ⁴³⁷
RX350				
V6 3.5L	VO-84	VA-273	VCA-2035	NS ⁴³⁷
RX450h				
V6 3.5L Hybrid	VO-84		VCA-2035	NS ⁴³⁷
2016				
CT200h				
4 cyl. 1.8L FI (Hybrid)	VO-102	VA-257	VCA-1031	NS ⁴³⁷
ES300H				
L4 2.5L (Hybrid)	VO-84	VA-309	VCA-1031	NS ⁴³⁷
ES350				
V6 3.5L	VO-84	VA-273	VCA-1031	NS ⁴³⁷
GS200t				
4 cyl. 2.0 FI	VO-84	VA-445	VCA-1122	NS ⁴³⁷
GS350				
V6 3.5L	VO-87	VA-445	VCA-1122	NS ⁴³⁷
GS450h				
V6 3.5L FI (Hybrid)	VO-87	VA-445	VCA-1122	NS ⁴³⁷
GS F				
V8 5.0L	VO-96		VCA-1122	NS ⁴³⁷
GX460				
V8 4.6L FI (1URFE)	VO-87	VA-256	VCA-1031	NS ⁴³⁷
IS200t				
4 cyl. 2.0L Turbo	VO-84	VA-445	VCA-1122	NS ⁴³⁷
IS300				
V6 3.5L FI (2GRFSE)	VO-87	VA-445	VCA-1122	NS ⁴³⁷
IS350				
V6 3.5L	VO-87	VA-445	VCA-1122	NS ⁴³⁷
LS460				
V8 4.6L FI (1URFSE)	VO-87	VA-309 ¹¹²	VCA-1031	NS ⁴³⁷

Se reporter à table de matière pour les notes en bas de page en français. Utilize el contenido para ver notas a pie.

NS - Non-Serviceable / Non réparable / No reparable LF - Life-Time Filter / Filtro para toda la vida / Filtre à vie

¹¹² Requires two (2). ⁴³⁷ Requires replacement of the complete fuel pump/fuel filter module.



LEXUS (cont'd)

2016

LS600h

V8 5.0L FI (Hybrid)	VO-87	VA-309 ¹¹²	VCA-1031	NS ⁴³⁷
---------------------	-------	-----------------------	----------	-------------------

LX570

V8 5.7L	VO-96	VA-234	VCA-1031	NS ⁴³⁷
---------	-------	--------	----------	-------------------

NX200t

4 cyl. 2.0 Turbo	VO-84	VA-273	VCA-1031	NS ⁴³⁷
------------------	-------	--------	----------	-------------------

NX300h

4 cyl. 2.5 Hybrid	VO-84	VA-257	VCA-1031	NS ⁴³⁷
-------------------	-------	--------	----------	-------------------

RC F

V8 5.0	VO-96		VCA-1122	NS ⁴³⁷
--------	-------	--	----------	-------------------

RC200t

4 cyl. 2.0L Turbo	VO-84	VA-445	VCA-1122	NS ⁴³⁷
-------------------	-------	--------	----------	-------------------

RC300

V6 3.5 FI	VO-87	VA-445	VCA-1122	NS ⁴³⁷
-----------	-------	--------	----------	-------------------

RC350

V6 3.5	VO-87	VA-445	VCA-1122	NS ⁴³⁷
--------	-------	--------	----------	-------------------

RX350

V6 3.5L	VO-84	VA-273	VCA-2035	NS ⁴³⁷
---------	-------	--------	----------	-------------------

RX450h

V6 3.5L Hybrid	VO-84		VCA-2035	NS ⁴³⁷
----------------	-------	--	----------	-------------------

2015

CT200h

4 cyl. 1.8L FI (Hybrid)	VO-102	VA-257	VCA-1031	NS ⁴³⁷
-------------------------	--------	--------	----------	-------------------

ES300H

L4 2.5L (Hybrid)	VO-84	VA-309	VCA-1031	NS ⁴³⁷
------------------	-------	--------	----------	-------------------

ES350

V6 3.5L	VO-84	VA-273	VCA-1031	NS ⁴³⁷
---------	-------	--------	----------	-------------------

GS350

V6 3.5L	VO-87	VA-445	VCA-1122	NS ⁴³⁷
---------	-------	--------	----------	-------------------

GS450h

V6 3.5L FI (Hybrid)	VO-87	VA-445	VCA-1122	NS ⁴³⁷
---------------------	-------	--------	----------	-------------------

GX460

V8 4.6L FI (1URFE)	VO-87	VA-256	VCA-1031	NS ⁴³⁷
--------------------	-------	--------	----------	-------------------

IS250

V6 2.5L FI (4GRFSE)	VO-87	VA-445	VCA-1122	NS ⁴³⁷
---------------------	-------	--------	----------	-------------------

IS350

V6 3.5L	VO-87	VA-445	VCA-1122	NS ⁴³⁷
---------	-------	--------	----------	-------------------

LS460

V8 4.6L FI (1URFSE)	VO-87	VA-309 ¹¹²	VCA-1031	NS ⁴³⁷
---------------------	-------	-----------------------	----------	-------------------

LS600h

V8 5.0L FI (Hybrid)	VO-87	VA-309 ¹¹²	VCA-1031	NS ⁴³⁷
---------------------	-------	-----------------------	----------	-------------------

LX570

V8 5.7L FI (3URFE)	VO-96	VA-234	VCA-1031	NS ⁴³⁷
--------------------	-------	--------	----------	-------------------

NX200t

4 cyl. 2.0 Turbo	VO-84	VA-273	VCA-1031	NS ⁴³⁷
------------------	-------	--------	----------	-------------------

NX300h

4 cyl. 2.5 Hybrid	VO-84	VA-257	VCA-1031	NS ⁴³⁷
-------------------	-------	--------	----------	-------------------

RC F

V8 5.0	VO-96		VCA-1122	NS ⁴³⁷
--------	-------	--	----------	-------------------

RC350

V6 3.5	VO-87	VA-445	VCA-1122	NS ⁴³⁷
--------	-------	--------	----------	-------------------

Se reporter à table de matière pour les notes en bas de page en français. Utilize el contenido para ver notas a pie.

NS - Non-Serviceable / Non réparable / No reparable LF - Life-Time Filter / Filtro para toda la vida / Filtre à vie

¹¹² Requires two (2). ⁴³⁷ Requires replacement of the complete fuel pump/fuel filter module.



LEXUS (cont'd)

	Oil	Air	Cabin*	Fuel
2015				
RX350				
V6 3.5L	VO-84	VA-273	VCA-1031	NS ⁴³⁷
RX450h				
V6 3.5L Hybrid	VO-84	VA-179	VCA-1031	NS ⁴³⁷
2014				
CT200h				
4 cyl. 1.8L FI (Hybrid)	VO-102	VA-257	VCA-1031	NS ⁴³⁷
ES300H				
L4 2.5L (Hybrid)	VO-84	VA-309	VCA-1031	NS ⁴³⁷
ES350				
V6 3.5L FI (2GRFE)	VO-84	VA-273	VCA-1031	NS ⁴³⁷
GS350				
V6 3.5L	VO-87	VA-445	VCA-1122	NS ⁴³⁷
GS450h				
V6 3.5L FI (Hybrid)	VO-87	VA-445	VCA-1122	NS ⁴³⁷
GX460				
V8 4.6L FI (1URFE)	VO-87	VA-256	VCA-1031	NS ⁴³⁷
IS250				
V6 2.5L FI (4GRFSE)	VO-87	VA-445	VCA-1122	NS ⁴³⁷
IS350				
V6 3.5L	VO-87	VA-445	VCA-1122	NS ⁴³⁷
IS F				
V8 5.0L FI (2URGSE)	VO-96		VCA-1031	NS ⁴³⁷
LS460				
V8 4.6L FI (1URFSE)	VO-87	VA-309 ¹¹²	VCA-1031	NS ⁴³⁷
LS600h				
V8 5.0L FI (Hybrid)	VO-87	VA-309 ¹¹²	VCA-1031	NS ⁴³⁷
LX570				
V8 5.7L FI (3URFE)	VO-96	VA-234	VCA-1031	NS ⁴³⁷
RX350				
V6 3.5L	VO-84	VA-273	VCA-1031	NS ⁴³⁷
RX450h				
V6 3.5L FI (Hybrid)	VO-84	VA-179	VCA-1031	NS ⁴³⁷
2013				
CT200h				
4 cyl. 1.8L FI (Hybrid)	VO-102	VA-257	VCA-1031	NS ⁴³⁷
ES300H				
L4 2.5L FI (Hybrid)	VO-84	VA-309	VCA-1031	NS ⁴³⁷
ES350				
V6 3.5L FI (2GRFE)	VO-84	VA-273	VCA-1031	NS ⁴³⁷
GS350				
V6 3.5L FI (2GRFSE)	VO-87	VA-445	VCA-1122	NS ⁴³⁷
GS450h				
V6 3.5L FI (Hybrid)	VO-87	VA-445	VCA-1122	NS ⁴³⁷
GX460				
V8 4.6L FI (1URFE)	VO-87	VA-256	VCA-1031	NS ⁴³⁷
IS250				
V6 2.5L FI (4GRFSE)	VO-87	VA-289	VCA-1031	NS ⁴³⁷
IS350				
V6 3.5L	VO-87	VA-289	VCA-1031	NS ⁴³⁷

Se reporter à table de matière pour les notes en bas de page en français. Utilize el contenido para ver notas a pie.

NS - Non-Serviceable / Non réparable / No repairable LF - Life-Time Filter / Filtro para toda la vida / Filtre à vie

¹¹² Requires two (2). ⁴³⁷ Requires replacement of the complete fuel pump/fuel filter module.



LEXUS (cont'd)

2013

IS F

V8 5.0L FI (2URGSE)	VO-96		VCA-1031	NS ⁴³⁷
---------------------	-------	--	----------	-------------------

LS460

V8 4.6L FI (1URFSE)	VO-87	VA-309 ¹¹²	VCA-1031	NS ⁴³⁷
---------------------	-------	-----------------------	----------	-------------------

LS600h

V8 5.0L FI (Hybrid)	VO-87	VA-309 ¹¹²	VCA-1031	NS ⁴³⁷
---------------------	-------	-----------------------	----------	-------------------

LX570

V8 5.7L FI (3URFE)	VO-96	VA-234	VCA-1031	NS ⁴³⁷
--------------------	-------	--------	----------	-------------------

RX350

V6 3.5L	VO-84	VA-273	VCA-1031	NS ⁴³⁷
---------	-------	--------	----------	-------------------

RX450h

V6 3.5L FI (Hybrid)	VO-84	VA-179	VCA-1031	NS ⁴³⁷
---------------------	-------	--------	----------	-------------------

2012

CT200h

4 cyl. 1.8L FI (Hybrid)	VO-102	VA-257	VCA-1031	NS ⁴³⁷
-------------------------	--------	--------	----------	-------------------

ES350

V6 3.5L FI (2GRFE)	VO-84	VA-209	VCA-1031	NS ⁴³⁷
--------------------	-------	--------	----------	-------------------

GX460

V8 4.6L FI (1URFE)	VO-87	VA-256	VCA-1031	NS ⁴³⁷
--------------------	-------	--------	----------	-------------------

HS250h

4 cyl. 2.4L FI (Hybrid)	VO-40	VA-309	VCA-1031	NS ⁴³⁷
-------------------------	-------	--------	----------	-------------------

IS250

V6 2.5L FI (4GRFSE)	VO-87	VA-289	VCA-1031	NS ⁴³⁷
---------------------	-------	--------	----------	-------------------

IS350

V6 3.5L	VO-87	VA-289	VCA-1031	NS ⁴³⁷
---------	-------	--------	----------	-------------------

IS F

V8 5.0L FI (2URGSE)	VO-96		VCA-1031	NS ⁴³⁷
---------------------	-------	--	----------	-------------------

LF-A

V10 4.8L FI			VCA-1031	NS ⁴³⁷
-------------	--	--	----------	-------------------

LS460

V8 4.6L FI (1URFSE)	VO-87	VA-309 ¹¹²	VCA-1031	NS ⁴³⁷
---------------------	-------	-----------------------	----------	-------------------

LS600h

V8 5.0L FI (Hybrid)	VO-87	VA-309 ¹¹²	VCA-1031	NS ⁴³⁷
---------------------	-------	-----------------------	----------	-------------------

RX350

V6 3.5L	VO-84	VA-273	VCA-1031	NS ⁴³⁷
---------	-------	--------	----------	-------------------

RX450h

V6 3.5L FI (Hybrid)	VO-84	VA-179	VCA-1031	NS ⁴³⁷
---------------------	-------	--------	----------	-------------------

2011

CT200h

4 cyl. 1.8L FI (Hybrid)	VO-102	VA-257	VCA-1031	NS ⁴³⁷
-------------------------	--------	--------	----------	-------------------

ES350

V6 3.5L FI (2GRFE)	VO-84	VA-209	VCA-1031	NS ⁴³⁷
--------------------	-------	--------	----------	-------------------

GS350

V6 3.5L FI (2GRFSE)	VO-87	VA-289	VCA-1031	NS ⁴³⁷
---------------------	-------	--------	----------	-------------------

GS450h

V6 3.5L FI (Hybrid)	VO-87	VA-279	VCA-1031	NS ⁴³⁷
---------------------	-------	--------	----------	-------------------

GS460

V8 4.6L FI (1URFSE)	VO-87	VA-445	VCA-1031	NS ⁴³⁷
---------------------	-------	--------	----------	-------------------

GX460

V8 4.6L FI (1URFE)	VO-87	VA-256	VCA-1031	NS ⁴³⁷
--------------------	-------	--------	----------	-------------------

Se reporter à table de matière pour les notes en bas de page en français. Utilize el contenido para ver notas a pie.

NS - Non-Serviceable / Non réparable / No reparable LF - Life-Time Filter / Filtro para toda la vida / Filtre à vie

¹¹² Requires two (2). ⁴³⁷ Requires replacement of the complete fuel pump/fuel filter module.



LEXUS (cont'd)

2011				
HS250h				
4 cyl. 2.4L FI (Hybrid)	VO-40	VA-309	VCA-1031	NS ⁴³⁷
IS250				
V6 2.5L FI (4GRFSE)	VO-87	VA-289	VCA-1031	NS ⁴³⁷
IS350				
V6 3.5L	VO-87	VA-289	VCA-1031	NS ⁴³⁷
IS F				
V8 5.0L FI (2URGSE)	VO-96		VCA-1031	NS ⁴³⁷
LS460				
V8 4.6L FI (1URFSE)	VO-87	VA-309 ¹¹²	VCA-1031	NS ⁴³⁷
LS600h				
V8 5.0L FI (Hybrid)	VO-87	VA-309 ¹¹²	VCA-1031	NS ⁴³⁷
LX570				
V8 5.7L FI (3URFE)	VO-96	VA-234	VCA-1031	NS ⁴³⁷
RX350				
V6 3.5L	VO-84	VA-273	VCA-1031	NS ⁴³⁷
RX450h				
V6 3.5L FI (Hybrid)	VO-84	VA-179	VCA-1031	NS ⁴³⁷
2010				
ES350				
V6 3.5L FI (2GRFE)	VO-84	VA-209	VCA-1031	NS ⁴³⁷
GS350				
V6 3.5L FI (2GRFSE)	VO-87	VA-289	VCA-1031	NS ⁴³⁷
GS450h				
V6 3.5L FI (Hybrid)	VO-87	VA-279	VCA-1031	NS ⁴³⁷
GS460				
V8 4.6L FI (1URFSE)	VO-87	VA-445	VCA-1031	NS ⁴³⁷
GX460				
V8 4.6L FI (1URFE)	VO-87	VA-256	VCA-1031	NS ⁴³⁷
HS250h				
4 cyl. 2.4L FI (Hybrid)	VO-40	VA-309	VCA-1031	NS ⁴³⁷
IS250				
V6 2.5L FI (4GRFSE)	VO-87	VA-289	VCA-1031	NS ⁴³⁷
IS350				
V6 3.5L	VO-87	VA-289	VCA-1031	NS ⁴³⁷
IS F				
V8 5.0L FI (2URGSE)	VO-96		VCA-1031	NS ⁴³⁷
LS460				
V8 4.6L FI (1URFSE)	VO-87	VA-309 ¹¹²	VCA-1031	NS ⁴³⁷
LS600h				
V8 5.0L FI (Hybrid)	VO-87	VA-309 ¹¹²	VCA-1031	NS ⁴³⁷
LX570				
V8 5.7L FI (3URFE)	VO-96	VA-234	VCA-1031	NS ⁴³⁷
RX350				
V6 3.5L FI (2GRFE)	VO-84	VA-273	VCA-1031	NS ⁴³⁷
RX450h				
V6 3.5L FI (Hybrid)	VO-84	VA-179	VCA-1031	NS ⁴³⁷
SC430				
V8 4.3L FI (3UZFE)	VO-25	VA-279	VCA-1129	NS ⁴³⁷

Se reporter à table de matière pour les notes en bas de page en français. Utilize el contenido para ver notas a pie.

NS - Non-Serviceable / Non réparable / No repairable LF - Life-Time Filter / Filtro para toda la vida / Filtre à vie

¹¹² Requires two (2). ⁴³⁷ Requires replacement of the complete fuel pump/fuel filter module.



LEXUS (cont'd)

2009

ES350

V6 3.5L FI (2GRFE)	VO-84	VA-209	VCA-1031	NS ⁴³⁷
--------------------	-------	--------	----------	-------------------

GS350

V6 3.5L FI (2GRFSE)	VO-87	VA-289	VCA-1031	NS ⁴³⁷
---------------------	-------	--------	----------	-------------------

GS450h

V6 3.5L FI (Hybrid)	VO-87	VA-279	VCA-1031	NS ⁴³⁷
---------------------	-------	--------	----------	-------------------

GS460

V8 4.6L FI (1URFSE)	VO-87	VA-445	VCA-1031	NS ⁴³⁷
---------------------	-------	--------	----------	-------------------

GX470

V8 4.7L FI (2UZFE)	VO-25	VA-146	VCA-1014 ¹¹³⁴	NS ⁴³⁷
--------------------	-------	--------	--------------------------	-------------------

IS250

V6 2.5L FI (4GRFSE)	VO-87	VA-289	VCA-1031	NS ⁴³⁷
---------------------	-------	--------	----------	-------------------

IS350

V6 3.5L FI (2GRFSE)	VO-87	VA-289	VCA-1031	NS ⁴³⁷
---------------------	-------	--------	----------	-------------------

IS F

V8 5.0L FI (2URGSE)	VO-96		VCA-1031	NS ⁴³⁷
---------------------	-------	--	----------	-------------------

LS460

V8 4.6L FI (1URFSE)	VO-87	VA-309 ¹¹²	VCA-1031	NS ⁴³⁷
---------------------	-------	-----------------------	----------	-------------------

LS600h

V8 5.0L FI (Hybrid)	VO-87	VA-309 ¹¹²	VCA-1031	NS ⁴³⁷
---------------------	-------	-----------------------	----------	-------------------

LX570

V8 5.7L FI (3URFE)	VO-96	VA-234	VCA-1031	NS ⁴³⁷
--------------------	-------	--------	----------	-------------------

RX350

V6 3.5L FI (2GRFE)	VO-84	VA-163	VCA-1014 ¹¹³⁴	NS ⁴³⁷
--------------------	-------	--------	--------------------------	-------------------

SC430

V8 4.3L FI (3UZFE)	VO-25	VA-279	VCA-1129	NS ⁴³⁷
--------------------	-------	--------	----------	-------------------

2008

ES350

V6 3.5L FI (2GRFE)	VO-84	VA-209	VCA-1031	NS ⁴³⁷
--------------------	-------	--------	----------	-------------------

GS350

V6 3.5L FI (2GRFSE)	VO-87	VA-289	VCA-1031	NS ⁴³⁷
---------------------	-------	--------	----------	-------------------

GS450h

V6 3.5L FI (Hybrid)	VO-87	VA-279	VCA-1031	NS ⁴³⁷
---------------------	-------	--------	----------	-------------------

GS460

V8 4.6L FI (1URFSE)	VO-87	VA-445	VCA-1031	NS ⁴³⁷
---------------------	-------	--------	----------	-------------------

GX470

V8 4.7L FI (2UZFE)	VO-25	VA-146	VCA-1014 ¹¹³⁴	NS ⁴³⁷
--------------------	-------	--------	--------------------------	-------------------

IS250

V6 2.5L FI (4GRFSE)	VO-87	VA-289	VCA-1031	NS ⁴³⁷
---------------------	-------	--------	----------	-------------------

IS350

V6 3.5L FI (2GRFSE)	VO-87	VA-289	VCA-1031	NS ⁴³⁷
---------------------	-------	--------	----------	-------------------

IS F

V8 5.0L FI (2URGSE)	VO-96		VCA-1031	
---------------------	-------	--	----------	--

LS460

V8 4.6L FI (1URFSE)	VO-87	VA-309 ¹¹²	VCA-1031	NS ⁴³⁷
---------------------	-------	-----------------------	----------	-------------------

LS600h

V8 5.0L FI (Hybrid)	VO-87	VA-309 ¹¹²	VCA-1031	NS ⁴³⁷
---------------------	-------	-----------------------	----------	-------------------

LX570

V8 5.7L FI (3URFE)	VO-96	VA-234	VCA-1031	NS ⁴³⁷
--------------------	-------	--------	----------	-------------------

RX350

V6 3.5L FI (2GRFE)	VO-84	VA-163	VCA-1014 ¹¹³⁴	NS ⁴³⁷
--------------------	-------	--------	--------------------------	-------------------

Se reporter à table de matière pour les notes en bas de page en français. Utilize el contenido para ver notas a pie.

NS - Non-Serviceable / Non réparable / No reparable LF - Life-Time Filter / Filtro para toda la vida / Filtre à vie

¹¹² Requires two (2). ⁴³⁷ Requires replacement of the complete fuel pump/fuel filter module. ¹¹³⁴Dust Filter. Replace with VCA-1032 when stock is depleted.



LEXUS (cont'd)

	Oil	Air	Cabin*	Fuel
2008				
RX400h				
V6 3.3L FI (Hybrid)	VO-25	VA-353	VCA-1014 ¹¹³⁴	NS ⁴³⁷
SC430				
V8 4.3L FI (3UZFE)	VO-25	VA-279	VCA-1129	NS ⁴³⁷
2007				
ES350				
V6 3.5L FI (2GRFE)	VO-84	VA-209	VCA-1031	NS ⁴³⁷
GS350				
V6 3.5L FI (2GRFSE)	VO-87	VA-289	VCA-1031	NS ⁴³⁷
GS430				
V8 4.3L FI (3UZFE)	VO-25	VA-289	VCA-1031	NS ⁴³⁷
GS450h				
V6 3.5L FI (Hybrid)	VO-87	VA-279	VCA-1031	NS ⁴³⁷
GX470				
V8 4.7L FI (2UZFE)	VO-25	VA-146	VCA-1014 ¹¹³⁴	NS ⁴³⁷
IS250				
V6 2.5L FI (4GRFSE)	VO-87	VA-289	VCA-1031	NS ⁴³⁷
IS350				
V6 3.5L FI (2GRFSE)	VO-87	VA-289	VCA-1031	NS ⁴³⁷
LS460				
V8 4.6L FI (1URFSE)	VO-87	VA-309 ¹¹²	VCA-1031	NS ⁴³⁷
LX470				
V8 4.7L FI (2UZFE)	VO-25	VA-146		
RX350				
V6 3.5L FI (2GRFE)	VO-84	VA-163	VCA-1014 ¹¹³⁴	NS ⁴³⁷
RX400h				
V6 3.3L FI (Hybrid)	VO-25	VA-353	VCA-1014 ¹¹³⁴	NS ⁴³⁷
SC430				
V8 4.3L FI (3UZFE)	VO-25	VA-279	VCA-1129	NS ⁴³⁷
2006				
ES330				
V6 3.3L FI (3MZFE)	VO-25	VA-163	VCA-1014 ¹¹³⁴	NS ⁴³⁷
GS300				
V6 3.0L	VO-87	VA-279	VCA-1031	NS ⁴³⁷
GS430				
V8 4.3L FI (3UZFE)	VO-25	VA-289	VCA-1031	NS ⁴³⁷
GX470				
V8 4.7L FI (2UZFE)	VO-25	VA-146	VCA-1014 ¹¹³⁴	NS ⁴³⁷
IS250				
V6 2.5L FI (4GRFSE)	VO-87	VA-289	VCA-1031	NS ⁴³⁷
IS350				
V6 3.5L FI (2GRFSE)	VO-87	VA-289	VCA-1031	NS ⁴³⁷
LS430				
V8 4.3L FI (3UZFE)	VO-25	VA-339	VCA-1129	NS ⁴³⁷
LX470				
V8 4.7L FI (2UZFE)	VO-25	VA-146		
RX330				
V6 3.3L FI (3MZFE)	VO-25	VA-163	VCA-1133	NS ⁴³⁷
RX400h				
V6 3.3L FI (Hybrid)	VO-25	VA-353	VCA-1014 ¹¹³⁴	NS ⁴³⁷

Se reporter à table de matière pour les notes en bas de page en français. Utilize el contenido para ver notas a pie.

NS - Non-Serviceable / Non réparable / No repairable LF - Life-Time Filter / Filtro para toda la vida / Filtre à vie

¹¹² Requires two (2). ⁴³⁷ Requires replacement of the complete fuel pump/fuel filter module. ¹¹³⁴ Dust Filter. Replace with VCA-1032 when stock is depleted.



LEXUS (cont'd)

2006

SC430

V8 4.3L FI (3UZFE)	VO-25	VA-279	VCA-1129	NS ⁴³⁷
--------------------	-------	--------	----------	-------------------

2005

ES330

V6 3.3L FI (3MZFE)	VO-25	VA-163	VCA-1014 ¹¹³⁴	NS ⁴³⁷
--------------------	-------	--------	--------------------------	-------------------

GS300

6 cyl. 3.0L FI (2JZGE)	VO-25	VA-159	VCA-1129	NS ⁴³⁷
------------------------	-------	--------	----------	-------------------

GS430

V8 4.3L FI (3UZFE)	VO-25	VA-279	VCA-1129	NS ⁴³⁷
--------------------	-------	--------	----------	-------------------

GX470

V8 4.7L FI (2UZFE)	VO-25	VA-146	VCA-1133	NS ⁴³⁷
--------------------	-------	--------	----------	-------------------

IS300

V6 3.0L FI (2JZGE)	VO-25	VA-159	VCA-1067	NS ⁴³⁷
--------------------	-------	--------	----------	-------------------

LS430

V8 4.3L FI (3UZFE)	VO-25	VA-339	VCA-1129	NS ⁴³⁷
--------------------	-------	--------	----------	-------------------

LX470

V8 4.7L FI (2UZFE)	VO-25	VA-146		
--------------------	-------	--------	--	--

RX330

V6 3.3L FI (3MZFE)	VO-25	VA-163	VCA-1133	NS ⁴³⁷
--------------------	-------	--------	----------	-------------------

SC430

V8 4.3L FI (3UZFE)	VO-25	VA-279	VCA-1129	NS ⁴³⁷
--------------------	-------	--------	----------	-------------------

2004

ES330

V6 3.3L FI (3MZFE)	VO-25	VA-163	VCA-1014 ¹¹³⁴	NS ⁴³⁷
--------------------	-------	--------	--------------------------	-------------------

GS300

6 cyl. 3.0L FI (2JZGE)	VO-25	VA-159	VCA-1129	NS ⁴³⁷
------------------------	-------	--------	----------	-------------------

GS430

V8 4.3L FI (3UZFE)	VO-25	VA-279	VCA-1129	NS ⁴³⁷
--------------------	-------	--------	----------	-------------------

GX470

V8 4.7L FI (2UZFE)	VO-25	VA-146	VCA-1133	NS ⁴³⁷
--------------------	-------	--------	----------	-------------------

IS300

V6 3.0L FI (2JZGE)	VO-25	VA-159	VCA-1067	NS ⁴³⁷
--------------------	-------	--------	----------	-------------------

LS430

V8 4.3L FI (3UZFE)	VO-25	VA-339	VCA-1129	NS ⁴³⁷
--------------------	-------	--------	----------	-------------------

LX470

V8 4.7L FI (2UZFE)	VO-25	VA-146		
--------------------	-------	--------	--	--

RX330

V6 3.3L FI (3MZFE)	VO-25	VA-163	VCA-1133	NS ⁴³⁷
--------------------	-------	--------	----------	-------------------

SC430

V8 4.3L FI (3UZFE)	VO-25	VA-279	VCA-1129	NS ⁴³⁷
--------------------	-------	--------	----------	-------------------

2003

ES300

V6 3.0L FI (1MZFE)	VO-25	VA-163	VCA-1133	NS ⁴³⁷
--------------------	-------	--------	----------	-------------------

GS300

6 cyl. 3.0L FI (2JZGE)	VO-25	VA-159	VCA-1129	NS ⁴³⁷
------------------------	-------	--------	----------	-------------------

GS430

V8 4.3L FI (3UZFE)	VO-25	VA-279	VCA-1129	NS ⁴³⁷
--------------------	-------	--------	----------	-------------------

GX470

V8 4.7L FI (2UZFE)	VO-25	VA-146	VCA-1133	NS ⁴³⁷
--------------------	-------	--------	----------	-------------------

IS300

V6 3.0L FI (2JZGE)	VO-25	VA-159	VCA-1067	NS ⁴³⁷
--------------------	-------	--------	----------	-------------------

Se reporter à table de matière pour les notes en bas de page en français. Utilize el contenido para ver notas a pie.

NS - Non-Serviceable / Non réparable / No reparable LF - Life-Time Filter / Filtro para toda la vida / Filtre à vie

⁴³⁷ Requires replacement of the complete fuel pump/fuel filter module. ¹¹³⁴Dust Filter. Replace with VCA-1032 when stock is depleted.



LEXUS (cont'd)

	Oil	Air	Cabin*	Fuel
2003				
LS430				
V8 4.3L FI (3UZFE)	VO-25	VA-339	VCA-1129	NS ⁴³⁷
LX470				
V8 4.7L FI (2UZFE)	VO-25	VA-146		
RX300				
V6 3.0L FI (1MZFE)	VO-25	VA-102	VCA-1067	NS ⁴³⁷
SC430				
V8 4.3L FI (3UZFE)	VO-25	VA-279	VCA-1129	NS ⁴³⁷
2002				
ES300				
V6 3.0L FI (1MZFE)	VO-25	VA-163	VCA-1133	NS ⁴³⁷
GS300				
6 cyl. 3.0L FI (2JZGE)	VO-25	VA-159	VCA-1129	NS ⁴³⁷
GS430				
V8 4.3L FI (3UZFE)	VO-25	VA-279	VCA-1129	NS ⁴³⁷
IS300				
V6 3.0L FI (2JZGE)	VO-25	VA-159	VCA-1067	NS ⁴³⁷
LS430				
V8 4.3L FI (3UZFE)	VO-25	VA-339	VCA-1129	NS ⁴³⁷
LX470				
V8 4.7L FI (2UZFE)	VO-25	VA-146		
RX300				
V6 3.0L FI (1MZFE)	VO-25	VA-102	VCA-1067	NS ⁴³⁷
SC430				
V8 4.3L FI (3UZFE)	VO-25	VA-279	VCA-1129	NS ⁴³⁷
2001				
ES300				
V6 3.0L FI (1MZFE)	VO-25	VA-102		
GS300				
6 cyl. 3.0L FI (2JZGE)	VO-25	VA-159	VCA-1129	NS ⁴³⁷
GS430				
V8 4.3L FI (3UZFE)	VO-25	VA-279	VCA-1129	NS ⁴³⁷
IS300				
V6 3.0L FI (2JZGE)	VO-25	VA-159	VCA-1067	NS ⁴³⁷
LS430				
V8 4.3L FI (3UZFE)	VO-25	VA-339	VCA-1129	NS ⁴³⁷
LX470				
V8 4.7L FI (2UZFE)	VO-25	VA-146		
RX300				
V6 3.0L FI (1MZFE)	VO-25	VA-102	VCA-1067	NS ⁴³⁷
2000				
ES300				
V6 3.0L FI (1MZFE)	VO-25	VA-102		
GS300				
6 cyl. 3.0L FI (2JZGE)	VO-25	VA-159	VCA-1024	NS ⁴³⁷
GS400				
V8 4.0L FI (1UZFE)	VO-25	VA-339	VCA-1024	NS ⁴³⁷
LS400				
V8 4.0L FI (1UZFE)	VO-25	VA-158		
LX470				
V8 4.7L FI (2UZFE)	VO-25	VA-146		

Se reporter à table de matière pour les notes en bas de page en français. Utilize el contenido para ver notas a pie.

NS - Non-Serviceable / Non réparable / No reparable LF - Life-Time Filter / Filtro para toda la vida / Filtre à vie

⁴³⁷ Requires replacement of the complete fuel pump/fuel filter module.



LEXUS (cont'd)

2000

RX300

V6 3.0L FI (1MZFE)	VO-25	VA-102	VCA-1067	NS ⁴³⁷
--------------------	-------	--------	----------	-------------------

SC300

6 cyl. 3.0L FI (2JZGE)	VO-25	VA-125		
------------------------	-------	--------	--	--

SC400

V8 4.0L FI (1UZFE)	VO-25	VA-125		
--------------------	-------	--------	--	--

1999

ES300

V6 3.0L FI (1MZFE)	VO-25	VA-102		
--------------------	-------	--------	--	--

GS300

6 cyl. 3.0L FI (2JZGE)	VO-25	VA-159	VCA-1024	NS ⁴³⁷
------------------------	-------	--------	----------	-------------------

GS400

V8 4.0L FI (1UZFE)	VO-25	VA-339	VCA-1024	NS ⁴³⁷
--------------------	-------	--------	----------	-------------------

LS400

V8 4.0L FI (1UZFE)	VO-25	VA-158		
--------------------	-------	--------	--	--

LX470

V8 4.7L FI (2UZFE)	VO-25	VA-146		
--------------------	-------	--------	--	--

RX300

V6 3.0L FI (1MZFE)	VO-25	VA-102	VCA-1067	NS ⁴³⁷
--------------------	-------	--------	----------	-------------------

SC300

6 cyl. 3.0L FI (2JZGE)	VO-25	VA-125		
------------------------	-------	--------	--	--

SC400

V8 4.0L FI (1UZFE)	VO-25	VA-125		
--------------------	-------	--------	--	--

1998

ES300

V6 3.0L FI (1MZFE)	VO-25	VA-102		
--------------------	-------	--------	--	--

GS300

6 cyl. 3.0L FI (2JZGE)	VO-25	VA-159	VCA-1024	NS ⁴³⁷
------------------------	-------	--------	----------	-------------------

GS400

V8 4.0L FI (1UZFE)	VO-25	VA-339	VCA-1024	NS ⁴³⁷
--------------------	-------	--------	----------	-------------------

LS400

V8 4.0L FI (1UZFE)	VO-25	VA-158		
--------------------	-------	--------	--	--

LX470

V8 4.7L FI (2UZFE)	VO-25	VA-146		
--------------------	-------	--------	--	--

SC300

6 cyl. 3.0L FI (2JZGE)	VO-25	VA-125		
------------------------	-------	--------	--	--

SC400

V8 4.0L FI (1UZFE)	VO-25	VA-125		
--------------------	-------	--------	--	--

1997

ES300

V6 3.0L FI (1MZFE)	VO-25	VA-102		
--------------------	-------	--------	--	--

GS300

6 cyl. 3.0L FI	VO-25			
----------------	-------	--	--	--

LS400

V8 4.0L FI	VO-25	VA-158		
------------	-------	--------	--	--

LX450

6 cyl. 4.5L FI	VO-25			
----------------	-------	--	--	--

SC300

6 cyl. 3.0L FI	VO-25	VA-125		
----------------	-------	--------	--	--

SC400

V8 4.0L FI	VO-25	VA-125		
------------	-------	--------	--	--

--	--	--	--	--

Se reporter à table de matière pour les notes en bas de page en français. Utilize el contenido para ver notas a pie.

NS - Non-Serviceable / Non réparable / No reparable LF - Life-Time Filter / Filtro para toda la vida / Filtre à vie

⁴³⁷ Requires replacement of the complete fuel pump/fuel filter module.



LEXUS (cont'd)

Year	Oil	Air	Cabin*	Fuel
1996				
ES300				
V6 3.0L FI	VO-25	VA-102		
GS300				
6 cyl. 3.0L FI	VO-25			
LS400				
V8 4.0L FI	VO-25	VA-158		
LX450				
6 cyl. 4.5L FI	VO-25			
SC300				
6 cyl. 3.0L FI	VO-25	VA-125		
SC400				
V8 4.0L FI	VO-25	VA-125		
1995				
ES300				
V6 3.0L FI	VO-25	VA-102		
GS300				
6 cyl. 3.0L FI	VO-25			
LS400				
V8 4.0L FI	VO-25	VA-158		
SC300				
6 cyl. 3.0L FI	VO-25	VA-125		
SC400				
V8 4.0L FI	VO-25	VA-125		

LINCOLN

Year	Oil	Air	Cabin*	Fuel
2019				
Continental				
V6 2.7L Turbo	VO-115	VA-306	VCA-1174	
V6 3.0L Turbo	VO-115	VA-306	VCA-1174	
V6 3.7L	VO-88	VA-306	VCA-1174	
MKC				
4 cyl. 2.0 Turbo	VO-25	VA-288	VCA-1081	NS ⁴³⁷
L4 2.3 Turbo	VO-25	VA-288	VCA-1081	NS ⁴³⁷
MKT				
V6 3.5L Turbo	VO-88	VA-224	VCA-1118	NS ⁴³⁷
V6 3.7L	VO-88	VA-224	VCA-1118	NS ⁴³⁷
MKZ				
4 cyl. 2.0L Hybrid	VO-25	VA-429	VCA-1174	
4 cyl. 2.0L Turbo	VO-25	VA-306	VCA-1174	
V6 3.0L Turbo	VO-115	VA-306	VCA-1174	
Nautilus				
4 cyl. 2.0L Turbo	VO-25	VA-306	VCA-1174	NS ⁴³⁷
V6 2.7L Turbo	VO-115	VA-306	VCA-1174	NS ⁴³⁷
Navigator				
V6 3.5L Turbo	VO-88	VA-223	VCA-1185	NS ⁴³⁷
2018				
Continental				
V6 2.7L Turbo	VO-115	VA-306	VCA-1174	
V6 3.0L Turbo	VO-115	VA-306	VCA-1174	
V6 3.7L	VO-88	VA-306	VCA-1174	
MKC				
4 cyl. 2.0 Turbo	VO-25	VA-288	VCA-1081	NS ⁴³⁷
L4 2.3 Turbo	VO-25	VA-288	VCA-1081	NS ⁴³⁷

Se reporter à table de matière pour les notes en bas de page en français. Utilize el contenido para ver notas a pie.

NS - Non-Serviceable / Non réparable / No repairable LF - Life-Time Filter / Filtro para toda la vida / Filtre à vie

⁴³⁷ Requires replacement of the complete fuel pump/fuel filter module.



LINCOLN (cont'd)

2018

MKT

V6 3.5L Turbo	VO-88	VA-224	VCA-1118	NS ⁴³⁷
V6 3.7L	VO-88	VA-224	VCA-1118	NS ⁴³⁷

MKX

V6 2.7L Turbo	VO-115	VA-306	VCA-1174	
V6 3.7L	VO-88	VA-306	VCA-1174	

MKZ

4 cyl. 2.0L Hybrid	VO-25	VA-429	VCA-1174	
4 cyl. 2.0L Turbo	VO-25	VA-306	VCA-1174	
V6 3.0L Turbo	VO-115	VA-306	VCA-1174	

Navigator

V6 3.5L Turbo	VO-88	VA-223	VCA-1185	NS ⁴³⁷
---------------	-------	--------	----------	-------------------

2017

Continental

V6 2.7L Turbo	VO-115	VA-306	VCA-1174	
V6 3.0L Turbo	VO-115	VA-306	VCA-1174	
V6 3.7L	VO-88	VA-306	VCA-1174	

MKC

4 cyl. 2.0 Turbo	VO-25	VA-288	VCA-1081	NS ⁴³⁷
L4 2.3 Turbo	VO-25	VA-288	VCA-1081	NS ⁴³⁷

MKT

V6 3.5L Turbo	VO-88	VA-224	VCA-1118	NS ⁴³⁷
V6 3.7L	VO-88	VA-224	VCA-1118	NS ⁴³⁷

MKX

V6 2.7L Turbo	VO-115	VA-306	VCA-1174	
V6 3.7L	VO-88	VA-306	VCA-1174	

MKZ

4 cyl. 2.0L Hybrid	VO-25	VA-429	VCA-1174	
4 cyl. 2.0L Turbo	VO-25	VA-306	VCA-1174	
V6 3.0L Turbo	VO-115	VA-306	VCA-1174	

Navigator

V6 3.5L Turbo	VO-88	VA-223		NS ⁴³⁷
---------------	-------	--------	--	-------------------

2016

MKC

4 cyl. 2.0 Turbo	VO-25	VA-288	VCA-1081	NS ⁴³⁷
L4 2.3 Turbo	VO-25	VA-288	VCA-1081	NS ⁴³⁷

MKS

V6 3.5L Turbo	VO-88	VA-224	VCA-1118	NS ⁴³⁷
V6 3.7L	VO-88	VA-224	VCA-1118	NS ⁴³⁷

MKT

4 cyl. 2.0L Turbo	VO-25	VA-224	VCA-1118	NS ⁴³⁷
V6 3.5L Turbo	VO-88	VA-224	VCA-1118	NS ⁴³⁷
V6 3.7L	VO-88	VA-224	VCA-1118	NS ⁴³⁷

MKX

V6 2.7L Turbo	VO-115	VA-306	VCA-1174	
V6 3.7L	VO-88	VA-306	VCA-1174	

MKZ

4 cyl. 2.0L Hybrid	VO-25	VA-429	VCA-1174	
4 cyl. 2.0L Turbo	VO-25	VA-306	VCA-1174	
V6 3.7L	VO-88	VA-306	VCA-1174	

Navigator

V6 3.5L Turbo	VO-88	VA-223		NS ⁴³⁷
---------------	-------	--------	--	-------------------

Se reporter à table de matière pour les notes en bas de page en français. Utilize el contenido para ver notas a pie.

NS - Non-Serviceable / Non réparable / No reparable LF - Life-Time Filter / Filtro para toda la vida / Filtre à vie

⁴³⁷ Requires replacement of the complete fuel pump/fuel filter module.



LINCOLN (cont'd)

	Oil	Air	Cabin*	Fuel
2015				
MKC				
4 cyl. 2.0 Turbo	VO-25	VA-288	VCA-1081	NS ⁴³⁷
L4 2.3 Turbo	VO-25	VA-288	VCA-1081	NS ⁴³⁷
MKS				
V6 3.5L Turbo	VO-88	VA-224	VCA-1118	NS ⁴³⁷
V6 3.7L	VO-88	VA-224	VCA-1118	NS ⁴³⁷
MKT				
4 cyl. 2.0L Turbo	VO-25	VA-224	VCA-1118	NS ⁴³⁷
V6 3.5L Turbo	VO-88	VA-224	VCA-1118	NS ⁴³⁷
V6 3.7L	VO-88	VA-224	VCA-1118	NS ⁴³⁷
MKX				
V6 3.7L	VO-88	VA-306	VCA-1049	NS ⁴³⁷
MKZ				
4 cyl. 2.0L Hybrid	VO-25	VA-429	VCA-1174	
4 cyl. 2.0L Turbo	VO-25	VA-306	VCA-1174	
V6 3.7L	VO-88	VA-306	VCA-1174	
Navigator				
V6 3.5L Turbo	VO-88	VA-223		NS ⁴³⁷
2014				
MKS				
V6 3.5L Turbo	VO-88	VA-224	VCA-1118	NS ⁴³⁷
V6 3.7L	VO-88	VA-224	VCA-1118	NS ⁴³⁷
MKT				
4 cyl. 2.0L Turbo	VO-25	VA-224	VCA-1118	NS ⁴³⁷
V6 3.5L Turbo	VO-88	VA-224	VCA-1118	NS ⁴³⁷
V6 3.7L	VO-88	VA-224	VCA-1118	NS ⁴³⁷
MKX				
V6 3.7L	VO-88	VA-224	VCA-1049	NS ⁴³⁷
MKZ				
4 cyl. 2.0L Hybrid	VO-25	VA-429	VCA-1174	NS ⁴³⁷
4 cyl. 2.0L Turbo	VO-25	VA-306	VCA-1174	NS ⁴³⁷
V6 3.7L	VO-88	VA-306	VCA-1174	NS ⁴³⁷
Navigator				
V8 5.4L (5) FI (Flex Fuel)	VO-88	VA-223		
2013				
MKS				
V6 3.5L Turbo	VO-88	VA-224	VCA-1118	NS ⁴³⁷
V6 3.7L	VO-88	VA-224	VCA-1118	NS ⁴³⁷
MKT				
4 cyl. 2.0L Turbo	VO-25	VA-224	VCA-1118	NS ⁴³⁷
V6 3.5L Turbo	VO-88	VA-224	VCA-1118	NS ⁴³⁷
V6 3.7L	VO-88	VA-224	VCA-1118	NS ⁴³⁷
MKX				
V6 3.7L	VO-88	VA-224	VCA-1049	NS ⁴³⁷
MKZ				
4 cyl. 2.0L Hybrid	VO-25	VA-429	VCA-1174	NS ⁴³⁷
4 cyl. 2.0L Turbo	VO-25	VA-306	VCA-1174	NS ⁴³⁷
V6 3.7L	VO-88	VA-306	VCA-1174	NS ⁴³⁷
Navigator				
V8 5.4L (5) FI (Flex Fuel)	VO-88	VA-223		

Se reporter à table de matière pour les notes en bas de page en français. Utilize el contenido para ver notas a pie.

NS - Non-Serviceable / Non réparable / No repairable LF - Life-Time Filter / Filtro para toda la vida / Filtre à vie

⁴³⁷ Requires replacement of the complete fuel pump/fuel filter module.



LINCOLN (cont'd)

2012

MKS

V6 3.5L Turbo	VO-88	VA-224	VCA-1118	NS ⁴³⁷
V6 3.7L	VO-88	VA-224	VCA-1118	NS ⁴³⁷

MKT

V6 3.5L Turbo	VO-88	VA-224	VCA-1118	NS ⁴³⁷
V6 3.7L	VO-88	VA-224	VCA-1118	NS ⁴³⁷

MKX

V6 3.7L	VO-88	VA-224	VCA-1049	NS ⁴³⁷
---------	-------	--------	----------	-------------------

MKZ

4 cyl. 2.5L Hybrid	VO-25		VCA-1059	NS ⁴³⁷
V6 3.5L	VO-88	VA-224	VCA-1059	NS ⁴³⁷

Navigator

V8 5.4L (5) FI (Flex Fuel)	VO-88	VA-223		
----------------------------	-------	--------	--	--

2011

MKS

V6 3.5L Turbo	VO-88	VA-224	VCA-1118	NS ⁴³⁷
V6 3.7L	VO-88	VA-224	VCA-1118	NS ⁴³⁷

MKT

V6 3.5L Turbo	VO-88	VA-224	VCA-1118	NS ⁴³⁷
V6 3.7L	VO-88	VA-224	VCA-1118	NS ⁴³⁷

MKX

V6 3.7L	VO-88	VA-224	VCA-1049	NS ⁴³⁷
---------	-------	--------	----------	-------------------

MKZ

4 cyl. 2.5L Hybrid	VO-25		VCA-1059	NS ⁴³⁷
V6 3.5L (C) FI	VO-88	VA-224	VCA-1059	NS ⁴³⁷

Navigator

V8 5.4L (5) FI (Flex Fuel)	VO-88	VA-223		
----------------------------	-------	--------	--	--

Town Car

V8 4.6L (V,W) FI	VO-88	VA-205		
------------------	-------	--------	--	--

2010

MKS

V6 3.5L Turbo	VO-88	VA-224	VCA-1118	NS ⁴³⁷
V6 3.7L	VO-88	VA-224	VCA-1118	NS ⁴³⁷

MKT

V6 3.5L Turbo	VO-88	VA-224	VCA-1118	NS ⁴³⁷
V6 3.7L	VO-88	VA-224	VCA-1118	NS ⁴³⁷

MKX

V6 3.5L FI	VO-88	VA-224	VCA-1049	NS ⁴³⁷
------------	-------	--------	----------	-------------------

MKZ

V6 3.5L (C) FI	VO-88	VA-224	VCA-1059	NS ⁴³⁷
----------------	-------	--------	----------	-------------------

Navigator

V8 5.4L (5) FI (Flex Fuel)	VO-88	VA-223		
----------------------------	-------	--------	--	--

Town Car

V8 4.6L (V,W) FI	VO-88	VA-205		
------------------	-------	--------	--	--

2009

MKS

V6 3.7L	VO-118 ^{X489} VO-88 ^{Z489}	VA-224		NS ⁴³⁷
---------	---	--------	--	-------------------

MKX

V6 3.5L FI	VO-118 ^{X486} VO-88 ^{Z486}	VA-224	VCA-1049	NS ⁴³⁷
------------	---	--------	----------	-------------------

Se reporter à table de matière pour les notes en bas de page en français. Utilize el contenido para ver notas a pie.

NS - Non-Serviceable / Non réparable / No repairable LF - Life-Time Filter / Filtro para toda la vida / Filtre à vie

⁴³⁷ Requires replacement of the complete fuel pump/fuel filter module. ^{X488}Before Production 1/16/09. ^{X489}Before Production 4/27/09. ^{Z486}After Production 1/15/09. ^{Z489}After Production 4/26/09.



LINCOLN (cont'd)

2009				
MKZ				
V6 3.5L (T) FI	VO-118 ^{X486} VO-88 ^{Z486}	VA-224		NS ⁴³⁷
Navigator				
V8 5.4L (5) FI (Flex Fuel)	VO-88	VA-223		
Town Car				
V8 4.6L (V,W) FI	VO-88	VA-205		
2008				
Mark LT				
V8 5.4L (5) FI	VO-88	VA-182		
MKX				
V6 3.5L FI	VO-118	VA-224	VCA-1049	NS ⁴³⁷
MKZ				
V6 3.5L (T) FI	VO-118	VA-224		NS ⁴³⁷
Navigator				
V8 5.4L (5) FI	VO-88	VA-223		
Town Car				
V8 4.6L (V,W) FI	VO-88	VA-205		
2007				
Mark LT				
V8 5.4L (5) FI	VO-88	VA-182		
MKX				
V6 3.5L FI	VO-118	VA-224	VCA-1049	NS ⁴³⁷
MKZ				
V6 3.5L (T) FI	VO-118	VA-224		NS ⁴³⁷
Navigator				
V8 5.4L (5) FI	VO-88	VA-223		
Town Car				
V8 4.6L (V,W) FI	VO-88	VA-205		
2006				
LS				
V8 3.9L (A) FI	VO-86	VA-142	VCA-1131	
Mark LT				
V8 5.4L (5) FI	VO-88	VA-182		
Navigator				
V8 5.4L (5) FI	VO-88	VA-182		
Town Car				
V8 4.6L (V,W) FI	VO-88	VA-205		
Zephyr				
V6 3.0L (1) FI	VO-88	VA-216		NS ⁴³⁷
2005				
Aviator				
V8 4.6L (H) FI	VO-88	VA-162		
LS				
V6 3.0L (S) FI	VO-118	VA-142	VCA-1131	
V8 3.9L (A) FI	VO-86	VA-142	VCA-1131	
Navigator				
V8 5.4L (5) FI	VO-88	VA-182		
Town Car				
V8 4.6L (W) FI	VO-88	VA-205		

Se reporter à table de matière pour les notes en bas de page en français. Utilize el contenido para ver notas a pie.

NS - Non-Serviceable / Non réparable / No reparable LF - Life-Time Filter / Filtro para toda la vida / Filtre à vie

⁴³⁷ Requires replacement of the complete fuel pump/fuel filter module. ^{X486} Before Production 1/16/09. ^{Z486} After Production 1/15/09.



LINCOLN (cont'd)

2004

Aviator

V8 4.6L (H) FI	VO-88	VA-162		
----------------	-------	--------	--	--

LS

V6 3.0L (S) FI	VO-118	VA-142	VCA-1131	
----------------	--------	--------	----------	--

V8 3.9L (A) FI	VO-86	VA-142	VCA-1131	
----------------	-------	--------	----------	--

Navigator

V8 5.4L (R) FI	VO-88	VA-94	VCA-1017 ⁵⁶¹	
----------------	-------	-------	-------------------------	--

Town Car

V8 4.6L (W) FI	VO-88	VA-205		
----------------	-------	--------	--	--

2003

Aviator

V8 4.6L (H) FI	VO-88	VA-162		
----------------	-------	--------	--	--

LS

V6 3.0L (S) FI	VO-118	VA-142	VCA-1131	
----------------	--------	--------	----------	--

V8 3.9L (A) FI	VO-86	VA-142	VCA-1131	
----------------	-------	--------	----------	--

Navigator

V8 5.4L (R) FI	VO-88	VA-94	VCA-1017 ⁵⁶¹	
----------------	-------	-------	-------------------------	--

Town Car

V8 4.6L (W) FI	VO-88	VA-205		
----------------	-------	--------	--	--

2002

Blackwood

V8 5.4L (A) FI DOHC	VO-88	VA-94	VCA-1017 ⁵⁶¹	
---------------------	-------	-------	-------------------------	--

Continental

V8 4.6L (V) FI	VO-88	VA-94		VG-16
----------------	-------	-------	--	-------

LS

V6 3.0L (S) FI	VO-118	VA-142	VCA-1125	
----------------	--------	--------	----------	--

V8 3.9L (A) FI	VO-86	VA-142	VCA-1125	
----------------	-------	--------	----------	--

Navigator

V8 5.4L (R) FI	VO-88	VA-94	VCA-1017 ⁵⁶¹	
----------------	-------	-------	-------------------------	--

Town Car

V8 4.6L (W) FI	VO-88	VA-205		
----------------	-------	--------	--	--

2001

Continental

V8 4.6L (V) FI	VO-88	VA-94		VG-16
----------------	-------	-------	--	-------

LS

V6 3.0L (S) FI	VO-118	VA-142	VCA-1125	
----------------	--------	--------	----------	--

V8 3.9L (A) FI	VO-86	VA-142	VCA-1125	
----------------	-------	--------	----------	--

Navigator

V8 5.4L (A,R) FI	VO-88	VA-94	VCA-1017 ⁵⁶¹	
------------------	-------	-------	-------------------------	--

Town Car

V8 4.6L (W) FI	VO-88	VA-205		
----------------	-------	--------	--	--

2000

Continental

V8 4.6L (V) FI	VO-88	VA-94		VG-16
----------------	-------	-------	--	-------

LS

V6 3.0L (S) FI	VO-118	VA-142	VCA-1125	
----------------	--------	--------	----------	--

V8 3.9L (A) FI	VO-86	VA-142	VCA-1125	
----------------	-------	--------	----------	--

Navigator

V8 5.4L (A) FI	VO-88	VA-94	VCA-1017 ⁵⁶¹	
----------------	-------	-------	-------------------------	--

Town Car

V8 4.6L (W) FI	VO-88	VA-205		
----------------	-------	--------	--	--

--	--	--	--	--

Se reporter à table de matière pour les notes en bas de page en français. Utilize el contenido para ver notas a pie.

NS - Non-Serviceable / Non réparable / No reparable. LF - Life-Time Filter / Filtro para toda la vida / Filtre à vie

⁵⁶¹ Ford kit# F65Z-18D477AA must be installed



LINCOLN (cont'd)

	Oil	Air	Cabin*	Fuel
1999				
Continental				
V8 4.6L (V) FI	VO-88	VA-94		VG-16
Navigator				
V8 5.4L (A,L) FI	VO-88	VA-94	VCA-1017 ⁵⁶¹	
Town Car				
V8 4.6L (W) FI	VO-88	VA-205		
1998				
Continental				
V8 4.6L (V) FI	VO-88	VA-94		VG-16
Mark VIII				
V8 4.6L (V) FI	VO-88			
Navigator				
V8 5.4L (L) FI	VO-88	VA-94	VCA-1017 ⁵⁶¹	VG-32
Town Car				
V8 4.6L (W) FI	VO-88	VA-205		
1997				
Continental				
V8 4.6L (V) FI	VO-88	VA-94		VG-16
Mark VIII				
V8 4.6L (V) FI	VO-88			
Town Car				
V8 4.6L (W) FI	VO-88	VA-205		VG-16
1996				
Continental				
V8 4.6L (V) FI	VO-88	VA-94		VG-16
Mark VIII				
V8 4.6L (V) FI	VO-88			
Town Car				
V8 4.6L (W) FI	VO-88	VA-205		VG-16
1995				
Continental				
V8 4.6L (V) FI	VO-88	VA-94		VG-16
Mark VIII				
V8 4.6L (V) FI	VO-88			
Town Car				
V8 4.6L (W) FI	VO-88	VA-205		VG-16
MAZDA				
2019				
CX3				
4 cyl. 2.0	VO-106			NS ⁴³⁷
CX5				
4 cyl. 2.5L Non turbo	VO-106	VA-302	VCA-1175	NS ⁴³⁷
4 cyl. 2.5L Turbo	VO-106		VCA-1175	NS ⁴³⁷
CX9				
4 cyl. 2.5L Turbo	VO-106		VCA-2035	NS ⁴³⁷
3				
4 cyl. 2.5L	VO-106	VA-302		NS ⁴³⁷
MX5 Miata				
4 cyl. 2.0L	VO-106			NS ⁴³⁷

Se reporter à table de matière pour les notes en bas de page en français. Utilize el contenido para ver notas a pie.

NS - Non-Serviceable / Non réparable / No reparable LF - Life-Time Filter / Filtro para toda la vida / Filtre à vie

⁴³⁷ Requires replacement of the complete fuel pump/fuel filter module. ⁵⁶¹ Ford kit# F65Z-18D477AA must be installed



MAZDA (cont'd)

2018

CX3

4 cyl. 2.0	VO-106			NS ⁴³⁷
------------	--------	--	--	-------------------

CX5

4 cyl. 2.5L	VO-106	VA-302	VCA-1175	NS ⁴³⁷
-------------	--------	--------	----------	-------------------

CX9

4 cyl. 2.5L Turbo	VO-106		VCA-2035	NS ⁴³⁷
-------------------	--------	--	----------	-------------------

3

4 cyl. 2.0L	VO-106	VA-302	VCA-1175	NS ⁴³⁷
-------------	--------	--------	----------	-------------------

4 cyl. 2.5L	VO-106	VA-302	VCA-1175	NS ⁴³⁷
-------------	--------	--------	----------	-------------------

6

4 cyl 2.5L	VO-106	VA-302	VCA-1175	NS ⁴³⁷
------------	--------	--------	----------	-------------------

4 cyl 2.5L Turbo	VO-106		VCA-1175	NS ⁴³⁷
------------------	--------	--	----------	-------------------

MX5 Miata

4 cyl. 2.0L	VO-106			NS ⁴³⁷
-------------	--------	--	--	-------------------

2017

CX3

4 cyl. 2.0	VO-106			NS ⁴³⁷
------------	--------	--	--	-------------------

CX5

4 cyl. 2.5L	VO-106	VA-302	VCA-1175	NS ⁴³⁷
-------------	--------	--------	----------	-------------------

CX9

4 cyl. 2.5L Turbo	VO-106		VCA-2035	NS ⁴³⁷
-------------------	--------	--	----------	-------------------

3

4 cyl. 2.0L	VO-106	VA-302	VCA-1175	NS ⁴³⁷
-------------	--------	--------	----------	-------------------

4 cyl. 2.5L	VO-106	VA-302	VCA-1175	NS ⁴³⁷
-------------	--------	--------	----------	-------------------

5

4 cyl 2.5L	VO-25	VA-207	VCA-1046	NS ⁴³⁷
------------	-------	--------	----------	-------------------

6

4 cyl 2.5L	VO-106	VA-302	VCA-1175	NS ⁴³⁷
------------	--------	--------	----------	-------------------

MX5 Miata

4 cyl. 2.0L	VO-106			NS ⁴³⁷
-------------	--------	--	--	-------------------

2016

CX3

4 cyl. 2.0	VO-106			NS ⁴³⁷
------------	--------	--	--	-------------------

CX5

4 cyl. 2.0L	VO-106	VA-302	VCA-1175	NS ⁴³⁷
-------------	--------	--------	----------	-------------------

4 cyl. 2.5L	VO-106	VA-302	VCA-1175	NS ⁴³⁷
-------------	--------	--------	----------	-------------------

CX9

4 cyl. 2.5L Turbo	VO-106		VCA-2035	NS ⁴³⁷
-------------------	--------	--	----------	-------------------

3

4 cyl. 2.0L	VO-106	VA-302	VCA-1175	NS ⁴³⁷
-------------	--------	--------	----------	-------------------

4 cyl. 2.5L	VO-106	VA-302	VCA-1175	NS ⁴³⁷
-------------	--------	--------	----------	-------------------

5

4 cyl 2.5L	VO-25	VA-207	VCA-1046	NS ⁴³⁷
------------	-------	--------	----------	-------------------

6

4 cyl 2.5L	VO-106	VA-302	VCA-1175	NS ⁴³⁷
------------	--------	--------	----------	-------------------

MX5 Miata

4 cyl. 2.0L	VO-106			NS ⁴³⁷
-------------	--------	--	--	-------------------

2015

CX5

4 cyl. 2.0L	VO-106	VA-302	VCA-1175	NS ⁴³⁷
-------------	--------	--------	----------	-------------------

4 cyl. 2.5L	VO-106	VA-302	VCA-1175	NS ⁴³⁷
-------------	--------	--------	----------	-------------------

Se reporter à table de matière pour les notes en bas de page en français. Utilize el contenido para ver notas a pie.

NS - Non-Serviceable / Non réparable / No reparable LF - Life-Time Filter / Filtro para toda la vida / Filtre à vie

⁴³⁷ Requires replacement of the complete fuel pump/fuel filter module.



MAZDA (cont'd)

	Oil	Air	Cabin*	Fuel
2015				
CX9				
V6 3.7L	VO-118	VA-224	VCA-1049	NS ⁴³⁷
2				
4 cyl. 1.5L	VO-106	VA-319	VCA-1098	NS ⁴³⁷
3				
4 cyl. 2.0L	VO-106	VA-302	VCA-1175	NS ⁴³⁷
4 cyl. 2.5L	VO-106	VA-302	VCA-1175	NS ⁴³⁷
5				
4 cyl. 2.5L	VO-25	VA-207	VCA-1046	NS ⁴³⁷
6				
4 cyl. 2.5L	VO-106	VA-302	VCA-1175	NS ⁴³⁷
MX5 Miata				
4 cyl. 2.0L	VO-25	VA-362		NS ⁴³⁷
2014				
CX5				
4 cyl. 2.0L	VO-106	VA-302	VCA-1175	NS ⁴³⁷
4 cyl. 2.5L	VO-106	VA-302	VCA-1175	NS ⁴³⁷
CX9				
V6 3.7L	VO-118	VA-224	VCA-1049	NS ⁴³⁷
2				
4 cyl. 1.5L	VO-106	VA-319	VCA-1098	NS ⁴³⁷
3				
4 cyl. 2.0L	VO-106	VA-302	VCA-1175	NS ⁴³⁷
4 cyl. 2.5L	VO-106	VA-302	VCA-1175	NS ⁴³⁷
5				
4 cyl. 2.5L	VO-25	VA-207	VCA-1046	NS ⁴³⁷
6				
4 cyl. 2.5L	VO-106	VA-302	VCA-1175	NS ⁴³⁷
MX5 Miata				
4 cyl. 2.0L	VO-25	VA-362		NS ⁴³⁷
2013				
CX5				
4 cyl. 2.0L	VO-106	VA-302	VCA-1175	NS ⁴³⁷
CX9				
V6 3.7L	VO-118	VA-224	VCA-1049	NS ⁴³⁷
2				
4 cyl. 1.5L	VO-106	VA-319	VCA-1098	NS ⁴³⁷
3				
4 cyl. 2.0L (F,G)	VO-25	VA-207	VCA-1094	NS ⁴³⁷
4 cyl. 2.0L (7,8,P) FI (SKYACTIV)	VO-106	VA-302	VCA-1094	NS ⁴³⁷
4 cyl. 2.3L Turbo	VO-25	VA-207	VCA-1094	NS ⁴³⁷
4 cyl. 2.5L	VO-25	VA-207	VCA-1094	NS ⁴³⁷
5				
4 cyl. 2.5L	VO-25	VA-207	VCA-1046	NS ⁴³⁷
6				
4 cyl. 2.5L	VO-25	VA-215	VCA-1116	NS ⁴³⁷
V6 3.7L	VO-118	VA-224	VCA-1116	NS ⁴³⁷
MX5 Miata				
4 cyl. 2.0L	VO-25	VA-362		NS ⁴³⁷
2012				
CX7				
4 cyl. 2.3L Turbo	VO-25	VA-194	VCA-1064	NS ⁴³⁷

Se reporter à table de matière pour les notes en bas de page en français. Utilize el contenido para ver notas a pie.

NS - Non-Serviceable / Non réparable / No reparable LF - Life-Time Filter / Filtro para toda la vida / Filtre à vie

⁴³⁷ Requires replacement of the complete fuel pump/fuel filter module.



MAZDA (cont'd)

2012

CX7

4 cyl. 2.5L	VO-25	VA-194	VCA-1064	NS ⁴³⁷
-------------	-------	--------	----------	-------------------

CX9

V6 3.7L	VO-118	VA-224	VCA-1049	NS ⁴³⁷
---------	--------	--------	----------	-------------------

2

4 cyl. 1.5L	VO-106	VA-319	VCA-1098	NS ⁴³⁷
-------------	--------	--------	----------	-------------------

3

4 cyl. 2.0L (F,G)	VO-25	VA-207	VCA-1094	NS ⁴³⁷
-------------------	-------	--------	----------	-------------------

4 cyl. 2.0L (7,8) FI (SKYACTIV)	VO-106	VA-302	VCA-1094	NS ⁴³⁷
---------------------------------	--------	--------	----------	-------------------

4 cyl. 2.3L Turbo	VO-25	VA-207	VCA-1094	NS ⁴³⁷
-------------------	-------	--------	----------	-------------------

4 cyl. 2.5L	VO-25	VA-207	VCA-1094	NS ⁴³⁷
-------------	-------	--------	----------	-------------------

5

4 cyl. 2.5L	VO-25	VA-207	VCA-1046	NS ⁴³⁷
-------------	-------	--------	----------	-------------------

6

4 cyl. 2.5L	VO-25	VA-215	VCA-1116	NS ⁴³⁷
-------------	-------	--------	----------	-------------------

V6 3.7L	VO-118	VA-224	VCA-1116	NS ⁴³⁷
---------	--------	--------	----------	-------------------

MX5 Miata

4 cyl. 2.0L	VO-25	VA-362		
-------------	-------	--------	--	--

2011

CX7

4 cyl. 2.3L Turbo	VO-25	VA-194	VCA-1064	NS ⁴³⁷
-------------------	-------	--------	----------	-------------------

4 cyl. 2.5L	VO-25	VA-194	VCA-1064	NS ⁴³⁷
-------------	-------	--------	----------	-------------------

CX9

V6 3.7L	VO-118	VA-224	VCA-1049	NS ⁴³⁷
---------	--------	--------	----------	-------------------

2

4 cyl. 1.5L	VO-106	VA-319	VCA-1098	NS ⁴³⁷
-------------	--------	--------	----------	-------------------

3

4 cyl. 2.0L	VO-25	VA-207	VCA-1094	NS ⁴³⁷
-------------	-------	--------	----------	-------------------

4 cyl. 2.3L Turbo	VO-25	VA-207	VCA-1094	NS ⁴³⁷
-------------------	-------	--------	----------	-------------------

4 cyl. 2.5L	VO-25	VA-207	VCA-1094	NS ⁴³⁷
-------------	-------	--------	----------	-------------------

6

4 cyl. 2.5L	VO-80 ^{X374}			
-------------	-----------------------	--	--	--

	VO-25 ^{Z374}	VA-215	VCA-1116	NS ⁴³⁷
--	-----------------------	--------	----------	-------------------

V6 3.7L	VO-118	VA-224	VCA-1116	NS ⁴³⁷
---------	--------	--------	----------	-------------------

MX5 Miata

4 cyl. 2.0L	VO-25	VA-362		
-------------	-------	--------	--	--

RX8

Rotary 1.3L	VO-106	VA-330	VCA-1089	NS ⁴³⁷
-------------	--------	--------	----------	-------------------

Tribute

4 cyl. 2.5L	VO-25	VA-149	VCA-1104	VG-32
-------------	-------	--------	----------	-------

V6 3.0L	VO-88	VA-246	VCA-1104	VG-32
---------	-------	--------	----------	-------

2010

B2300

4 cyl. 2.3L (D) FI (Canada)	VO-25	VA-322		
-----------------------------	-------	--------	--	--

B4000

V6 4.0L (E) FI (Canada)	VO-88	VA-322		
-------------------------	-------	--------	--	--

CX7

4 cyl. 2.3L Turbo	VO-25	VA-194	VCA-1064	NS ⁴³⁷
-------------------	-------	--------	----------	-------------------

4 cyl. 2.5L	VO-25	VA-194	VCA-1064	NS ⁴³⁷
-------------	-------	--------	----------	-------------------

CX9

V6 3.7L	VO-118	VA-224	VCA-1049	NS ⁴³⁷
---------	--------	--------	----------	-------------------

Se reporter à table de matière pour les notes en bas de page en français. Utilize el contenido para ver notas a pie.

NS - Non-Serviceable / Non réparable / No reparable LF - Life-Time Filter / Filtro para toda la vida / Filtre à vie

⁴³⁷ Requires replacement of the complete fuel pump/fuel filter module. ^{X374}Cartridge ^{Z374}Spin-on



MAZDA (cont'd)

	Oil	Air	Cabin*	Fuel
2010				
3				
4 cyl. 2.0L	VO-25	VA-207	VCA-1094	NS ⁴³⁷
4 cyl. 2.3L Turbo	VO-25	VA-207	VCA-1094	NS ⁴³⁷
4 cyl. 2.5L	VO-25	VA-207	VCA-1094	NS ⁴³⁷
5				
4 cyl 2.3L	VO-80 ^{X374} VO-25 ^{Z374}	VA-207	VCA-1046	NS ⁴³⁷
6				
4 cyl 2.5L	VO-80 ^{X374} VO-25 ^{Z374}	VA-215	VCA-1116	NS ⁴³⁷
V6 3.7L	VO-118	VA-224	VCA-1116	NS ⁴³⁷
MX5 Miata				
4 cyl. 2.0L	VO-25	VA-362		
RX8				
Rotary 1.3L	VO-106	VA-330	VCA-1089	NS ⁴³⁷
Tribute				
4 cyl 2.5L	VO-80 ^{X374} VO-25 ^{Z374}	VA-149	VCA-1104	VG-32
4 cyl 2.5L (Hybrid)	VO-80 ^{X374} VO-25 ^{Z374}	VA-249	VCA-1104 ^{X909} VCA-1101 ^{Z909}	VG-32
V6 3.0L (G)	VO-88	VA-246	VCA-1104	VG-32
2009				
B2300				
4 cyl. 2.3L (D) FI	VO-25	VA-322		
B4000				
V6 4.0L (E) FI	VO-88	VA-322		
CX7				
4 cyl 2.3L Turbo	VO-80	VA-194	VCA-1064	NS ⁴³⁷
CX9				
V6 3.7L	VO-118	VA-224	VCA-1049	NS ⁴³⁷
3				
4 cyl. 2.0L FI	VO-25	VA-207	VCA-1046	NS ⁴³⁷
4 cyl. 2.3L FI Non Turbo	VO-80	VA-207	VCA-1046	NS ⁴³⁷
4 cyl. 2.3L FI Turbo	VO-80	VA-207	VCA-1046	NS ⁴³⁷
5				
4 cyl 2.3L FI	VO-80 ^{X374} VO-25 ^{Z374}	VA-207	VCA-1046	NS ⁴³⁷
6				
4 cyl 2.5L	VO-80 ^{X374} VO-25 ^{Z374}	VA-215	VCA-1116	NS ⁴³⁷
V6 3.7L	VO-118	VA-224	VCA-1116	NS ⁴³⁷
MX5 Miata				
4 cyl. 2.0L FI	VO-25	VA-362		
RX8				
Rotary 1.3L FI	VO-106	VA-330	VCA-1089	NS ⁴³⁷
Tribute				
4 cyl 2.5L	VO-80 ^{X374} VO-25 ^{Z374}	VA-149	VCA-1104	VG-32
4 cyl 2.5L (Hybrid)	VO-80 ^{X374} VO-25 ^{Z374}	VA-249	VCA-1104 ^{X909} VCA-1101 ^{Z909}	VG-32
V6 3.0L	VO-88	VA-246	VCA-1104	VG-32

Se reporter à table de matière pour les notes en bas de page en français. Utilize el contenido para ver notas a pie.

NS - Non-Serviceable / Non réparable / No reparable LF - Life-Time Filter / Filtro para toda la vida / Filtre à vie

⁴³⁷ Requires replacement of the complete fuel pump/fuel filter module. ^{X374}Cartridge ^{X909}Dust filter ^{Z374}Spin-on ^{Z909}High Voltage battery pack on driver side rear cargo trim panel.



MAZDA (cont'd)

2008

B2300

4 cyl. 2.3L (D) FI	VO-25	VA-322		
--------------------	-------	--------	--	--

B3000

V6 3.0L (U) FI (Canada)	VO-118	VA-322		
-------------------------	--------	--------	--	--

B4000

V6 4.0L (E) FI	VO-88	VA-322		
----------------	-------	--------	--	--

CX7

4 cyl 2.3L Turbo	VO-80	VA-194	VCA-1064	NS ⁴³⁷
------------------	-------	--------	----------	-------------------

CX9

V6 3.7L	VO-118	VA-224	VCA-1049	NS ⁴³⁷
---------	--------	--------	----------	-------------------

3

4 cyl. 2.0L FI	VO-25	VA-207	VCA-1046	NS ⁴³⁷
4 cyl. 2.3L FI Non Turbo	VO-80	VA-207	VCA-1046	NS ⁴³⁷
4 cyl. 2.3L FI Turbo	VO-80	VA-207	VCA-1046	NS ⁴³⁷

5

4 cyl 2.3L FI	VO-80	VA-207	VCA-1046	NS ⁴³⁷
---------------	-------	--------	----------	-------------------

6

4 cyl. 2.3L FI	VO-80	VA-190	VCA-1070	NS ⁴³⁷
V6 3.0L FI	VO-88	VA-194	VCA-1070	NS ⁴³⁷

MX5 Miata

4 cyl. 2.0L FI	VO-25	VA-362		
----------------	-------	--------	--	--

RX8

Rotary 1.3L FI	VO-106	VA-330	VCA-1089	NS ⁴³⁷
----------------	--------	--------	----------	-------------------

Tribute

4 cyl 2.3L (Hybrid)	VO-80	VA-249	VCA-1104 ^{X909} VCA-1101 ^{Z909}	VG-32
4 cyl. 2.3L (Z)	VO-25	VA-149	VCA-1104	VG-32
V6 3.0L (1)	VO-88	VA-149	VCA-1104	VG-32

2007

B2300

4 cyl. 2.3L (D) FI	VO-25	VA-322		
--------------------	-------	--------	--	--

B3000

V6 3.0L (U) FI	VO-118	VA-322		
----------------	--------	--------	--	--

B4000

V6 4.0L (E) FI	VO-88	VA-322		
----------------	-------	--------	--	--

CX7

4 cyl 2.3L Turbo	VO-80	VA-194	VCA-1064	NS ⁴³⁷
------------------	-------	--------	----------	-------------------

CX9

V6 3.5L	VO-118	VA-224	VCA-1049	NS ⁴³⁷
---------	--------	--------	----------	-------------------

3

4 cyl. 2.0L FI	VO-25	VA-207	VCA-1046	NS ⁴³⁷
4 cyl 2.3L FI Turbo	VO-80	VA-207	VCA-1046	NS ⁴³⁷
4 cyl. 2.3L FI Non Turbo	VO-80	VA-207	VCA-1046	NS ⁴³⁷

5

4 cyl 2.3L FI	VO-80	VA-207	VCA-1046	NS ⁴³⁷
---------------	-------	--------	----------	-------------------

6

4 cyl. 2.3L FI Non Turbo	VO-80	VA-190	VCA-1070	NS ⁴³⁷
4 cyl. 2.3L FI Turbo	VO-80	VA-194	VCA-1070	NS ⁴³⁷
V6 3.0L FI	VO-88	VA-194	VCA-1070	NS ⁴³⁷

MX5 Miata

4 cyl. 2.0L FI	VO-25	VA-362		
----------------	-------	--------	--	--

Se reporter à table de matière pour les notes en bas de page en français. Utilize el contenido para ver notas a pie.

NS - Non-Serviceable / Non réparable / No reparable LF - Life-Time Filter / Filtro para toda la vida / Filtre à vie

⁴³⁷ Requires replacement of the complete fuel pump/fuel filter module. ^{X909}Dust filter ^{Z909}High Voltage battery pack on driver side rear cargo trim panel.



MAZDA (cont'd)

	Oil	Air	Cabin*	Fuel
2007				
RX8				
Rotary 1.3L FI	VO-106	VA-330	VCA-1089	NS ⁴³⁷
2006				
B2300				
4 cyl. 2.3L (D) FI	VO-25	VA-322		
B3000				
V6 3.0L (U) FI	VO-118	VA-322		
B4000				
V6 4.0L (E) FI	VO-88	VA-322		
3				
4 cyl. 2.0L FI	VO-25	VA-207	VCA-1046	NS ⁴³⁷
4 cyl. 2.3L FI	VO-80	VA-207	VCA-1046	NS ⁴³⁷
5				
4 cyl. 2.3L FI	VO-80	VA-207	VCA-1046	NS ⁴³⁷
6				
4 cyl. 2.3L FI Non Turbo	VO-80	VA-190	VCA-1070	NS ⁴³⁷
4 cyl. 2.3L FI Turbo	VO-80	VA-194	VCA-1070	NS ⁴³⁷
V6 3.0L FI	VO-88	VA-194	VCA-1070	NS ⁴³⁷
MPV				
V6 3.0L FI	VO-88	VA-190	VCA-1089	NS ⁴³⁷
MX5 Miata				
4 cyl. 2.0L FI	VO-25	VA-362		
RX8				
Rotary 1.3L FI	VO-106	VA-330	VCA-1089	NS ⁴³⁷
Tribute				
4 cyl. 2.3L (Z) FI	VO-25	VA-149	VCA-1020	VG-16
V6 3.0L (1)	VO-88	VA-149	VCA-1020	VG-16
2005				
B2300				
4 cyl. 2.3L (D) FI	VO-118	VA-322		
B3000				
V6 3.0L (U) FI	VO-118	VA-322		
B4000				
V6 4.0L (E) FI	VO-88	VA-322		
3				
4 cyl. 2.0L FI	VO-25	VA-207	VCA-1046	NS ⁴³⁷
4 cyl. 2.3L FI	VO-80	VA-207	VCA-1046	NS ⁴³⁷
6				
4 cyl. 2.3L FI	VO-80	VA-190	VCA-1070	NS ⁴³⁷
V6 3.0L FI	VO-88	VA-194	VCA-1070	NS ⁴³⁷
Miata				
4 cyl. 1.8L FI Non Turbo	VO-106	VA-397		
4 cyl. 1.8L FI Turbo	VO-106	VA-397		
MPV				
V6 3.0L FI	VO-88	VA-190	VCA-1089	NS ⁴³⁷
RX8				
Rotary 1.3L FI	VO-106	VA-330	VCA-1089	NS ⁴³⁷
Tribute				
4 cyl. 2.3L (Z)	VO-25	VA-149	VCA-1020	VG-16
V6 3.0L	VO-88	VA-149	VCA-1020	VG-16

Se reporter à table de matière pour les notes en bas de page en français. Utilize el contenido para ver notas a pie.

NS - Non-Serviceable / Non réparable / No repairable LF - Life-Time Filter / Filtro para toda la vida / Filtre à vie

⁴³⁷ Requires replacement of the complete fuel pump/fuel filter module.



MAZDA (cont'd)

2004

B2300

4 cyl. 2.3L (D) FI	VO-118	VA-322		
--------------------	--------	--------	--	--

B3000

V6 3.0L (U) FI	VO-118	VA-322		
----------------	--------	--------	--	--

B4000

V6 4.0L (E) FI	VO-88	VA-322		
----------------	-------	--------	--	--

3

4 cyl. 2.0L FI	VO-25	VA-207	VCA-1046	NS ⁴³⁷
----------------	-------	--------	----------	-------------------

4 cyl. 2.3L FI	VO-80	VA-207	VCA-1046	NS ⁴³⁷
----------------	-------	--------	----------	-------------------

6

4 cyl. 2.3L FI	VO-80	VA-190	VCA-1070	NS ⁴³⁷
----------------	-------	--------	----------	-------------------

V6 3.0L FI	VO-88	VA-194	VCA-1070	NS ⁴³⁷
------------	-------	--------	----------	-------------------

Miata

4 cyl. 1.8L FI Non Turbo	VO-106	VA-397		
--------------------------	--------	--------	--	--

4 cyl. 1.8L FI Turbo	VO-106	VA-397		
----------------------	--------	--------	--	--

MPV

V6 3.0L FI	VO-88	VA-190	VCA-1089	NS ⁴³⁷
------------	-------	--------	----------	-------------------

RX8

Rotary 1.3L FI	VO-106	VA-330	VCA-1089	NS ⁴³⁷
----------------	--------	--------	----------	-------------------

Tribute

4 cyl. 2.0L	VO-118	VA-149	VCA-1020	VG-16
-------------	--------	--------	----------	-------

V6 3.0L	VO-88	VA-149	VCA-1020	VG-16
---------	-------	--------	----------	-------

2003

B2300

4 cyl. 2.3L (D) FI	VO-118	VA-260		
--------------------	--------	--------	--	--

B3000

V6 3.0L (U) FI	VO-118	VA-260		
----------------	--------	--------	--	--

V6 3.0L (V) FI (Flex Fuel)	VO-118	VA-260		
----------------------------	--------	--------	--	--

B4000

V6 4.0L (E) FI	VO-88	VA-260		
----------------	-------	--------	--	--

6

4 cyl. 2.3L FI	VO-80	VA-190	VCA-1070	NS ⁴³⁷
----------------	-------	--------	----------	-------------------

V6 3.0L FI	VO-88	VA-194	VCA-1070	NS ⁴³⁷
------------	-------	--------	----------	-------------------

Miata

4 cyl. 1.8L FI	VO-106	VA-397		
----------------	--------	--------	--	--

MPV

V6 3.0L FI	VO-88	VA-190	VCA-1014 ¹¹³⁴	NS ⁴³⁷
------------	-------	--------	--------------------------	-------------------

Protege'

4 cyl. 1.6L FI (Canada)	VO-106	VFAP-7893		NS ⁴³⁷
-------------------------	--------	-----------	--	-------------------

4 cyl. 2.0L FI Non Turbo	VO-106	VFAP-7893		NS ⁴³⁷
--------------------------	--------	-----------	--	-------------------

4 cyl. 2.0L FI Turbo	VO-106	VFAP-7893		NS ⁴³⁷
----------------------	--------	-----------	--	-------------------

Tribute

4 cyl. 2.0L	VO-118	VA-149	VCA-1020	VG-16
-------------	--------	--------	----------	-------

V6 3.0L	VO-88	VA-149	VCA-1020	VG-16
---------	-------	--------	----------	-------

2002

626

4 cyl. 2.0L FI	VO-106	VA-136		
----------------	--------	--------	--	--

V6 2.5L FI	VO-106	VA-136		
------------	--------	--------	--	--

B2300

4 cyl. 2.3L (D) FI	VO-118	VA-260		
--------------------	--------	--------	--	--

B3000

V6 3.0L (U) FI	VO-118	VA-260		
----------------	--------	--------	--	--

Se reporter à table de matière pour les notes en bas de page en français. Utilize el contenido para ver notas a pie.

NS - Non-Serviceable / Non réparable / No repairable LF - Life-Time Filter / Filtro para toda la vida / Filtre à vie

⁴³⁷ Requires replacement of the complete fuel pump/fuel filter module. ¹¹³⁴Dust Filter. Replace with VCA-1032 when stock is depleted.



MAZDA (cont'd)

	Oil	Air	Cabin*	Fuel
2002				
B3000				
V6 3.0L (V) FI (Flex Fuel)	VO-118	VA-260		
B4000				
V6 4.0L (E) FI	VO-88	VA-260		
Miata				
4 cyl. 1.8L FI	VO-106	VA-397		
Millenia				
V6 2.3L FI (S.C.)	VO-106	VFAP-7892		
V6 2.5L FI	VO-106	VA-104		
MPV				
V6 3.0L FI	VO-88	VA-190	VCA-1014 ¹¹³⁴	NS ⁴³⁷
Protege'				
4 cyl. 1.6L FI (Canada)	VO-106	VFAP-7893		NS ⁴³⁷
4 cyl. 2.0L FI	VO-106	VFAP-7893		NS ⁴³⁷
Tribute				
4 cyl. 2.0L	VO-118	VA-149	VCA-1020	VG-16
V6 3.0L	VO-88	VA-149	VCA-1020	VG-16
2001				
626				
4 cyl. 2.0L FI	VO-106	VA-136		
V6 2.5L FI	VO-106	VA-136		
B2300				
4 cyl. 2.3L (D) FI	VO-118	VA-260		
B2500				
4 cyl. 2.5L (C) FI	VO-118	VA-260		
B3000				
V6 3.0L (U) FI	VO-118	VA-260		
V6 3.0L (V) FI (Flex Fuel)	VO-118	VA-260		
B4000				
V6 4.0L (E) FI	VO-88	VA-260		
Miata				
4 cyl. 1.8L FI	VO-106	VA-397		
Millenia				
V6 2.3L FI (S.C.)	VO-106	VFAP-7892		
V6 2.5L FI	VO-106	VA-104		
MPV				
V6 2.5L FI	VO-88	VA-190	VCA-1014 ¹¹³⁴	NS ⁴³⁷
Protege'				
4 cyl. 1.6L FI	VO-106	VFAP-7893		NS ⁴³⁷
4 cyl. 2.0L FI	VO-106	VFAP-7893		NS ⁴³⁷
Tribute				
4 cyl. 2.0L	VO-118	VA-149	VCA-1020	VG-16
V6 3.0L	VO-88	VA-149	VCA-1020	VG-16
2000				
626				
4 cyl. 2.0L FI	VO-106	VA-136		
V6 2.5L FI	VO-106	VA-136		
B2500				
4 cyl. 2.5L (C) FI	VO-118	VA-260		
B3000				
V6 3.0L (V) FI (Flex Fuel)	VO-118	VA-260		

Se reporter à table de matière pour les notes en bas de page en français. Utilize el contenido para ver notas a pie.

NS - Non-Serviceable / Non réparable / No reparable LF - Life-Time Filter / Filtro para toda la vida / Filtre à vie

⁴³⁷ Requires replacement of the complete fuel pump/fuel filter module. ¹¹³⁴Dust Filter. Replace with VCA-1032 when stock is depleted.



MAZDA (cont'd)

2000

B4000

V6 4.0L (X) FI	VO-1 ^{X502} VO-118 ^{Z502}	VA-260		
----------------	--	--------	--	--

Miata

4 cyl. 1.8L FI	VO-106	VA-397		
----------------	--------	--------	--	--

Millenia

V6 2.3L FI (S.C.)	VO-106	VFAP-7892		
V6 2.5L FI	VO-106	VA-104		

MPV

V6 2.5L FI	VO-88	VA-190	VCA-1014 ¹¹³⁴	NS ⁴³⁷
------------	-------	--------	--------------------------	-------------------

Protege'

4 cyl. 1.6L FI	VO-106	VFAP-7893		NS ⁴³⁷
4 cyl. 1.8L FI	VO-106	VFAP-7893		NS ⁴³⁷

1999

626

4 cyl. 2.0L FI	VO-106	VA-136		
V6 2.5L FI	VO-106	VA-136		

B2500

4 cyl. 2.5L (C) FI	VO-118	VA-260		
--------------------	--------	--------	--	--

B3000

V6 3.0L (U) FI	VO-118	VA-260		
V6 3.0L (V) FI (Flex Fuel)	VO-118	VA-260		

B4000

V6 4.0L (X) FI	VO-1 ^{X502} VO-118 ^{Z502}	VA-260		
----------------	--	--------	--	--

Miata

4 cyl. 1.8L FI	VO-106	VA-397		
----------------	--------	--------	--	--

Millenia

V6 2.3L FI (S.C.)	VO-106	VFAP-7892		
V6 2.5L FI	VO-106	VA-104		

Protege'

4 cyl. 1.6L FI	VO-106	VFAP-7893		NS ⁴³⁷
4 cyl. 1.8L FI	VO-106	VFAP-7893		NS ⁴³⁷

1998

626

4 cyl. 2.0L FI	VO-106	VA-136		
V6 2.5L FI	VO-106	VA-136		

B2500

4 cyl. 2.5L (C) FI	VO-118	VA-260		
--------------------	--------	--------	--	--

B3000

V6 3.0L (U) FI	VO-118	VA-260		
----------------	--------	--------	--	--

B4000

V6 4.0L (X) FI	VO-1 ^{X502} VO-118 ^{Z502}	VA-260		
----------------	--	--------	--	--

Millenia

V6 2.3L FI (S.C.)	VO-106	VFAP-7892		
V6 2.5L FI	VO-106	VA-104		

MPV

V6 3.0L FI	VO-106			
------------	--------	--	--	--

Protege'

4 cyl. 1.5L FI	VO-106	VFAP-7893		
4 cyl. 1.8L FI	VO-106	VFAP-7893		

Se reporter à table de matière pour les notes en bas de page en français. Utilize el contenido para ver notas a pie.

NS - Non-Serviceable / Non réparable / No reparable LF - Life-Time Filter / Filtro para toda la vida / Filtre à vie

⁴³⁷ Requires replacement of the complete fuel pump/fuel filter module. ¹¹³⁴Dust Filter. Replace with VCA-1032 when stock is depleted. ^{X502}Alternate

^{Z502}Primary



MAZDA (cont'd)

	Oil	Air	Cabin*	Fuel
1997				
626				
4 cyl. 2.0L FI	VO-106	VA-106		
V6 2.5L FI	VO-106	VA-106		
B2300				
4 cyl. 2.3L (A) FI	VO-1 ^{X502} VO-118 ^{Z502}	VA-114		VG-32
B3000				
V6 3.0L (U) FI	VO-118	VA-114		VG-32
B4000				
V6 4.0L (X) FI	VO-1 ^{X502} VO-118 ^{Z502}	VA-114		VG-32
Miata				
4 cyl. 1.8L FI	VO-106	VA-416		
Millenia				
V6 2.3L FI (S.C.)	VO-106	VFAP-7892		
V6 2.5L FI	VO-106	VA-104		
MPV				
V6 3.0L FI	VO-106			
MX6				
4 cyl. 2.0L FI	VO-106	VA-106		
V6 2.5L FI	VO-106	VA-106		
Protege'				
4 cyl. 1.5L FI	VO-106	VFAP-7893		
4 cyl. 1.8L FI	VO-106	VFAP-7893		
1996				
626				
4 cyl. 2.0L FI	VO-106	VA-106		
V6 2.5L FI	VO-106	VA-106		
B2300				
4 cyl. 2.3L (A) FI	VO-1 ^{X502} VO-118 ^{Z502}	VA-114		VG-32
B3000				
V6 3.0L (U) FI	VO-118	VA-114		VG-32
B4000				
V6 4.0L (X) FI	VO-1 ^{X502} VO-118 ^{Z502}	VA-114		VG-32
Miata				
4 cyl. 1.8L FI	VO-106	VA-416		
Millenia				
V6 2.3L FI (S.C.)	VO-106	VFAP-7892		
V6 2.5L FI	VO-106	VA-104		
MPV				
V6 3.0L FI	VO-106			
MX6				
4 cyl. 2.0L FI	VO-106	VA-106		
V6 2.5L FI	VO-106	VA-106		
Precida (Canada)				
4 cyl. 1.6L FI	VO-106			
Protege'				
4 cyl. 1.5L FI	VO-106	VFAP-7893		
4 cyl. 1.8L FI	VO-106	VFAP-7893		

Se reporter à table de matière pour les notes en bas de page en français. Utilize el contenido para ver notas a pie.

NS - Non-Serviceable / Non réparable / No reparable LF - Life-Time Filter / Filtro para toda la vida / Filtre à vie

^{X502}Alternate ^{Z502}Primary



MAZDA (cont'd)

1995

323

4 cyl. 1.6L FI (Canada)	VO-106	VA-416		
4 cyl. 1.8L FI (Canada)	VO-106	VA-416		

626

4 cyl. 2.0L FI	VO-106	VA-106		
V6 2.5L FI	VO-106	VA-106		

929

V6 3.0L FI	VO-106	VA-96		
------------	--------	-------	--	--

B2300

4 cyl. 2.3L (A) FI	VO-1 ^{X502} VO-118 ^{Z502}	VA-114		VG-32
--------------------	--	--------	--	-------

B3000

V6 3.0L (U) FI	VO-118	VA-114		VG-32
----------------	--------	--------	--	-------

B4000

V6 4.0L (X) FI	VO-1 ^{X502} VO-118 ^{Z502}	VA-114		VG-32
----------------	--	--------	--	-------

Miata

4 cyl. 1.8L FI	VO-106	VA-416		
----------------	--------	--------	--	--

Millenia

V6 2.3L FI (S.C.)	VO-106	VFAP-7892		
V6 2.5L FI	VO-106	VA-104		

MPV

V6 3.0L FI	VO-106			
------------	--------	--	--	--

MX3

4 cyl. 1.6L FI	VO-106			
V6 1.8L FI (Canada)	VO-106			

MX6

4 cyl. 2.0L FI	VO-106	VA-106		
V6 2.5L FI	VO-106	VA-106		

Precida (Canada)

4 cyl. 1.6L FI	VO-106			
----------------	--------	--	--	--

Protege'

4 cyl. 1.5L FI	VO-106	VFAP-7893		
4 cyl. 1.8L FI	VO-106	VFAP-7893		

RX7

4 cyl. 1.3L FI Turbo	VO-106			
----------------------	--------	--	--	--

MERCEDES-BENZ

2019

AMG GT

V8 4.0L Turbo			VCA-1153	
---------------	--	--	----------	--

A220

4 cyl. 2.0L Turbo	VO-164			NS ⁴³⁷
-------------------	--------	--	--	-------------------

B250 (Canada)

4 cyl. 2.0 Turbo	VO-164	VA-449		LF ⁴⁵⁰
------------------	--------	--------	--	-------------------

C300

4 cyl. 2.0L Turbo	VO-164			NS ⁴³⁷
-------------------	--------	--	--	-------------------

C350e

4 cyl. 2.0L Turbo (Hybrid)	VO-164			NS
----------------------------	--------	--	--	----

C43 AMG

V6 3.0 Turbo	VO-149			LF ⁴⁵⁰
--------------	--------	--	--	-------------------

C63 AMG

V8 4.0L Turbo				LF ⁴⁵⁰
---------------	--	--	--	-------------------

Se reporter à table de matière pour les notes en bas de page en français. Utilize el contenido para ver notas a pie.

NS - Non-Serviceable / Non réparable / No reparable. LF - Life-Time Filter / Filtro para toda la vida / Filtre à vie

⁴³⁷ Requires replacement of the complete fuel pump/fuel filter module. ⁴⁵⁰ Lifetime filter. Does not require replacement under normal conditions. ^{X502} Alternate

^{Z502} Primary



MERCEDES-BENZ (cont'd)

	Oil	Air	Cabin*	Fuel
2019				
CLA250				
4 cyl. 2.0 Turbo	VO-164	VA-449		NS ⁴³⁷
CLA45 AMG				
4 cyl. 2.0 Turbo				LF ⁴⁵⁰
E300				
4 cyl. 2.0L Turbo	VO-164			LF
E450				
V6 3.0L Turbo	VO-149			NS ⁴³⁷
E63 AMG				
V8 4.0L Turbo				LF ⁴⁵⁰
G550				
V8 4.0L Turbo				LF ⁴⁵⁰
GLA250				
4 cyl. 2.0 Turbo	VO-164	VA-449		NS ⁴³⁷
GLC300				
4 cyl. 2.0 Turbo	VO-164			NS ⁴³⁷
GLC350e				
4 cyl. 2.0L Turbo	VO-164			NS ⁴³⁷
GLC43 AMG				
V6 3.0 Turbo	VO-149			NS ⁴³⁷
GLE400				
V6 3.0 Turbo	VO-149			LF ⁴⁵⁰
GLE43 AMG				
V6 3.0 Turbo	VO-149			LF ⁴⁵⁰
GLE63 AMG				
V8 5.5 Turbo		VA-452 ¹¹²		LF ⁴⁵⁰
GLS450				
V6 3.0L Turbo	VO-149			LF ⁴⁵⁰
GLS550				
V8 4.6L Turbo	VO-149 ¹⁰⁴⁸	VA-452 ¹¹²		LF ⁴⁵⁰
GLS63 AMG				
V8 5.5L Turbo		VA-452 ¹¹²		LF ⁴⁵⁰
Metris				
4 cyl. 2.0L Turbo	VO-164			NS ⁴³⁷
S450				
V6 3.0L Turbo	VO-149			
S560				
V8 4.0 Turbo				LF ⁴⁵⁰
S63 AMG				
V8 4.0L Turbo				LF ⁴⁵⁰
S65 AMG				
V12 6.0L Turbo				LF ⁴⁵⁰
SL450				
V6 3.0L Turbo	VO-149		VCA-1153	LF ⁴⁵⁰
SL550				
V8 4.6L Turbo	VO-149 ¹⁰⁴⁸	VA-452 ¹¹²	VCA-1153	LF ⁴⁵⁰
SLC300				
4 cyl. 2.0L Turbo	VO-164			NS ⁴³⁷
SLC43				
V6 3.0L Turbo	VO-149			NS ⁴³⁷
Sprinter Van				
V6 3.0L Diesel Turbo	VO-129	VA-349		

Se reporter à table de matière pour les notes en bas de page en français. Utilize el contenido para ver notas a pie.

NS - Non-Serviceable / Non réparable / No reparable LF - Life-Time Filter / Filtro para toda la vida / Filtre à vie

¹¹² Requires two (2). ⁴³⁷ Requires replacement of the complete fuel pump/fuel filter module. ⁴⁵⁰ Lifetime filter. Does not require replacement under normal conditions. ¹⁰⁴⁸Models requiring filter with stem.



MERCEDES-BENZ (cont'd)

2018

AMG GT

V8 4.0L Turbo			VCA-1153	
---------------	--	--	----------	--

B250 (Canada)

4 cyl. 2.0 Turbo	VO-164	VA-449		LF ⁴⁵⁰
------------------	--------	--------	--	-------------------

C300

4 cyl. 2.0L Turbo	VO-164			NS ⁴³⁷
-------------------	--------	--	--	-------------------

C350e

4 cyl. 2.0L Turbo (Hybrid)	VO-164			NS
----------------------------	--------	--	--	----

C43 AMG

V6 3.0 Turbo	VO-149			LF ⁴⁵⁰
--------------	--------	--	--	-------------------

C63 AMG

V8 4.0L Turbo				LF ⁴⁵⁰
---------------	--	--	--	-------------------

CLA250

4 cyl. 2.0 Turbo	VO-164	VA-449		NS ⁴³⁷
------------------	--------	--------	--	-------------------

CLA45 AMG

4 cyl. 2.0 Turbo				LF ⁴⁵⁰
------------------	--	--	--	-------------------

CLS400

V6 3.0L Turbo	VO-149		VCA-1153	LF ⁴⁵⁰
---------------	--------	--	----------	-------------------

CLS550

V8 4.6L Turbo	VO-149 ¹⁰⁴⁸	VA-452 ¹¹²	VCA-1153	LF ⁴³⁷
---------------	------------------------	-----------------------	----------	-------------------

CLS63 AMG

V8 5.5L Turbo		VA-452 ¹¹²	VCA-1153	NS ⁴⁵⁰
---------------	--	-----------------------	----------	-------------------

E300

4 cyl. 2.0L Turbo	VO-164			LF
-------------------	--------	--	--	----

E400

V6 3.0L Turbo	VO-149			NS ⁴³⁷
---------------	--------	--	--	-------------------

E43 AMG

V6 3.0 FI Turbo	VO-149			NS
-----------------	--------	--	--	----

E63 AMG

V8 4.0L Turbo				LF ⁴⁵⁰
---------------	--	--	--	-------------------

G550

V8 4.0L Turbo				LF ⁴⁵⁰
---------------	--	--	--	-------------------

G63 AMG

V8 5.5 Turbo		VA-452 ¹¹²		
--------------	--	-----------------------	--	--

G65 AMG

V12 6.0				LF
---------	--	--	--	----

GLA250

4 cyl. 2.0 Turbo	VO-164	VA-449		NS ⁴³⁷
------------------	--------	--------	--	-------------------

GLC300

4 cyl. 2.0 Turbo	VO-164			NS ⁴³⁷
------------------	--------	--	--	-------------------

GLC350e

4 cyl. 2.0L Turbo	VO-164			NS ⁴³⁷
-------------------	--------	--	--	-------------------

GLC43 AMG

V6 3.0 Turbo	VO-149			NS ⁴³⁷
--------------	--------	--	--	-------------------

GLE350

V6 3.5L	VO-149	VA-442		LF ⁴⁵⁰
---------	--------	--------	--	-------------------

GLE400

V6 3.0 Turbo	VO-149			LF ⁴⁵⁰
--------------	--------	--	--	-------------------

GLE43 AMG

V6 3.0 Turbo	VO-149			LF ⁴⁵⁰
--------------	--------	--	--	-------------------

GLE550e

V6 3.0L Turbo (Hybrid)	VO-149			LF ⁴⁵⁰
------------------------	--------	--	--	-------------------

Se reporter à table de matière pour les notes en bas de page en français. Utilize el contenido para ver notas a pie.

NS - Non-Serviceable / Non réparable / No reparable LF - Life-Time Filter / Filtro para toda la vida / Filtre à vie

¹¹² Requires two (2). ⁴³⁷ Requires replacement of the complete fuel pump/fuel filter module. ⁴⁵⁰ Lifetime filter. Does not require replacement under normal conditions. ¹⁰⁴⁸ Models requiring filter with stem.



MERCEDES-BENZ (cont'd)

	Oil	Air	Cabin*	Fuel
2018				
GLE550				
V8 4.6		VA-452 ¹¹²		LF ⁴⁵⁰
GLE63 AMG				
V8 5.5 Turbo		VA-452 ¹¹²		LF ⁴⁵⁰
GLS450				
V6 3.0L Turbo	VO-149			LF ⁴⁵⁰
GLS550				
V8 4.6L Turbo	VO-149 ¹⁰⁴⁸	VA-452 ¹¹²		LF ⁴⁵⁰
GLS63 AMG				
V8 5.5L Turbo		VA-452 ¹¹²		LF ⁴⁵⁰
Metris				
4 cyl. 2.0L Turbo	VO-164			NS ⁴³⁷
S450				
V6 3.0L Turbo	VO-149			
S550e				
V6 3.0 FI Turbo (Hybrid)	VO-149			LF ⁴⁵⁰
S560				
V8 4.0 Turbo				LF ⁴⁵⁰
S63 AMG				
V8 4.0L Turbo				LF ⁴⁵⁰
S65 AMG				
V12 6.0L Turbo				LF ⁴⁵⁰
SL450				
V6 3.0L Turbo	VO-149		VCA-1153	LF ⁴⁵⁰
SL550				
V8 4.6L Turbo	VO-149 ¹⁰⁴⁸	VA-452 ¹¹²	VCA-1153	LF ⁴⁵⁰
SL63 AMG				
V8 5.5L Turbo		VA-452 ¹¹²	VCA-1153	LF ⁴⁵⁰
SL65 AMG				
V12 6.0L Turbo			VCA-1153	LF ⁴⁵⁰
SLC300				
4 cyl. 2.0L Turbo	VO-164			NS ⁴³⁷
SLC43				
V6 3.0L Turbo	VO-149			NS ⁴³⁷
Sprinter Van				
V6 3.0L Diesel Turbo	VO-129	VA-349	VCA-1142	
2017				
AMG GT				
V8 4.0L Turbo			VCA-1153	
B250 (Canada)				
4 cyl. 2.0 Turbo	VO-164	VA-449		LF ⁴⁵⁰
C300				
4 cyl. 2.0L Turbo	VO-164			NS ⁴³⁷
C350e				
4 cyl. 2.0L Turbo (Hybrid)	VO-164			NS
C43 AMG				
V6 3.0 Turbo	VO-149			LF ⁴⁵⁰
C63 AMG				
V8 4.0L Turbo				LF ⁴⁵⁰
CLA250				
4 cyl. 2.0 Turbo	VO-164	VA-449		NS ⁴³⁷

Se reporter à table de matière pour les notes en bas de page en français. Utilize el contenido para ver notas a pie.

NS - Non-Serviceable / Non réparable / No reparable LF - Life-Time Filter / Filtro para toda la vida / Filtre à vie

¹¹² Requires two (2). ⁴³⁷ Requires replacement of the complete fuel pump/fuel filter module. ⁴⁵⁰ Lifetime filter. Does not require replacement under normal conditions. ¹⁰⁴⁸Models requiring filter with stem.



MERCEDES-BENZ (cont'd)

2017

CLA45 AMG

4 cyl. 2.0 Turbo				LF ⁴⁵⁰
------------------	--	--	--	-------------------

CLS400

V6 3.0L Turbo	VO-149		VCA-1153	LF ⁴⁵⁰
---------------	--------	--	----------	-------------------

CLS550

V8 4.6L Turbo	VO-149 ¹⁰⁴⁸	VA-452 ¹¹²	VCA-1153	LF ⁴³⁷
---------------	------------------------	-----------------------	----------	-------------------

CLS63 AMG

V8 5.5L Turbo		VA-452 ¹¹²	VCA-1153	NS ⁴⁵⁰
---------------	--	-----------------------	----------	-------------------

E300

4 cyl. 2.0L Turbo	VO-164			LF
-------------------	--------	--	--	----

E400

V6 3.0L Turbo	VO-149		VCA-1153	NS ⁴³⁷
---------------	--------	--	----------	-------------------

E43 AMG

V6 3.0 FI Turbo	VO-149			NS
-----------------	--------	--	--	----

E550

V8 4.6L FI Turbo	VO-149 ¹⁰⁴⁸	VA-452 ¹¹²	VCA-1153	NS ⁴³⁷
------------------	------------------------	-----------------------	----------	-------------------

G550

V8 4.0L Turbo				LF ⁴⁵⁰
---------------	--	--	--	-------------------

G63 AMG

V8 5.5 Turbo		VA-452 ¹¹²		
--------------	--	-----------------------	--	--

G65 AMG

V12 6.0				LF
---------	--	--	--	----

GLA250

4 cyl. 2.0 Turbo	VO-164	VA-449		NS ⁴³⁷
------------------	--------	--------	--	-------------------

GLC300

4 cyl. 2.0 Turbo	VO-164			NS ⁴³⁷
------------------	--------	--	--	-------------------

GLC43 AMG

V6 3.0 Turbo	VO-149			NS ⁴³⁷
--------------	--------	--	--	-------------------

GLE350

V6 3.5L	VO-149	VA-442		LF ⁴⁵⁰
---------	--------	--------	--	-------------------

GLE400

V6 3.0 Turbo	VO-149			LF ⁴⁵⁰
--------------	--------	--	--	-------------------

GLE43 AMG

V6 3.0 Turbo	VO-149			LF ⁴⁵⁰
--------------	--------	--	--	-------------------

GLE550e

V6 3.0L Turbo (Hybrid)	VO-149			LF ⁴⁵⁰
------------------------	--------	--	--	-------------------

GLE550

V8 4.6		VA-452 ¹¹²		LF ⁴⁵⁰
--------	--	-----------------------	--	-------------------

GLE63 AMG

V8 5.5 Turbo		VA-452 ¹¹²		LF ⁴⁵⁰
--------------	--	-----------------------	--	-------------------

GLS450

V6 3.0L Turbo	VO-149			LF ⁴⁵⁰
---------------	--------	--	--	-------------------

GLS550

V8 4.6L Turbo	VO-149 ¹⁰⁴⁸	VA-452 ¹¹²		LF
---------------	------------------------	-----------------------	--	----

GLS63 AMG

V8 5.5L Turbo		VA-452 ¹¹²		LF
---------------	--	-----------------------	--	----

Maybach S550

V8 4.6 Turbo	VO-149 ¹⁰⁴⁸	VA-452 ¹¹²		
--------------	------------------------	-----------------------	--	--

Metris

4 cyl. 2.0L Turbo	VO-164			NS ⁴³⁷
-------------------	--------	--	--	-------------------

S550

V8 4.6L Turbo	VO-149 ¹⁰⁴⁸	VA-452 ¹¹²		LF ⁴⁵⁰
---------------	------------------------	-----------------------	--	-------------------

Se reporter à table de matière pour les notes en bas de page en français. Utilize el contenido para ver notas a pie.

NS - Non-Serviceable / Non réparable / No reparable LF - Life-Time Filter / Filtro para toda la vida / Filtre à vie

¹¹² Requires two (2). ⁴³⁷ Requires replacement of the complete fuel pump/fuel filter module. ⁴⁵⁰ Lifetime filter. Does not require replacement under normal conditions. ¹⁰⁴⁸ Models requiring filter with stem.



MERCEDES-BENZ (cont'd)

	Oil	Air	Cabin*	Fuel
2017				
S550e				
V6 3.0 FI Turbo (Hybrid)	VO-149			LF ⁴⁵⁰
S600				
V12 6.0L Turbo				LF ⁴⁵⁰
S63 AMG				
V8 5.5L Turbo		VA-452 ¹¹²		LF ⁴⁵⁰
S65 AMG				
V12 6.0L Turbo				LF ⁴⁵⁰
SL450				
V6 3.0L Turbo	VO-149		VCA-1153	LF ⁴⁵⁰
SL550				
V8 4.6L Turbo	VO-149 ¹⁰⁴⁸	VA-452 ¹¹²	VCA-1153	LF ⁴⁵⁰
SL63 AMG				
V8 5.5L Turbo		VA-452 ¹¹²	VCA-1153	LF ⁴⁵⁰
SL65 AMG				
V12 6.0L Turbo			VCA-1153	LF ⁴⁵⁰
SLC300				
4 cyl. 2.0L Turbo	VO-164			NS ⁴³⁷
SLC43				
V6 3.0L Turbo	VO-149			NS ⁴³⁷
Sprinter Van				
4 cyl. 2.1L Diesel Turbo		VA-349	VCA-1142	
V6 3.0L Diesel Turbo	VO-129	VA-349	VCA-1142	
2016				
AMG GT				
V8 4.0L Turbo			VCA-1153	
B250 (Canada)				
4 cyl. 2.0 Turbo	VO-164	VA-449		LF ⁴⁵⁰
C300				
4 cyl. 2.0L Turbo	VO-164			NS ⁴³⁷
C350				
V6 3.5L	VO-149	VA-442	VCA-1153	NS ⁴³⁷
C350e				
4 cyl. 2.0L Turbo (Hybrid)	VO-164			NS
C450 AMG				
V8 3.0L Turbo	VO-149			
C63 AMG				
V8 4.0L Turbo				LF ⁴⁵⁰
CLA250				
4 cyl. 2.0 Turbo	VO-164	VA-449		NS ⁴³⁷
CLS400				
V6 3.0L Turbo	VO-149		VCA-1153	LF ⁴⁵⁰
CLS550				
V8 4.6L Turbo	VO-149 ¹⁰⁴⁸	VA-452 ¹¹²	VCA-1153	LF ⁴³⁷
CLS63 AMG				
V8 5.5L Turbo		VA-452 ¹¹²	VCA-1153	NS ⁴⁵⁰
E250 BlueTec				
4 cyl. 2.1 Diesel Turbo			VCA-1153	
E350				
V6 3.5L	VO-149	VA-442	VCA-1153	NS ⁴³⁷
E400				
V6 3.0L Turbo	VO-149		VCA-1153	NS ⁴³⁷

Se reporter à table de matière pour les notes en bas de page en français. Utilize el contenido para ver notas a pie.

NS - Non-Serviceable / Non réparable / No repairable LF - Life-Time Filter / Filtro para toda la vida / Filtre à vie

¹¹² Requires two (2). ⁴³⁷ Requires replacement of the complete fuel pump/fuel filter module. ⁴⁵⁰ Lifetime filter. Does not require replacement under normal conditions. ¹⁰⁴⁸Models requiring filter with stem.



MERCEDES-BENZ (cont'd)

2016

E550

V8 4.6L FI Turbo	VO-149 ¹⁰⁴⁸	VA-452 ¹¹²	VCA-1153	NS ⁴³⁷
------------------	------------------------	-----------------------	----------	-------------------

E63 AMG

V8 5.5L FI Turbo		VA-452 ¹¹²	VCA-1153	LF ⁴⁵⁰
------------------	--	-----------------------	----------	-------------------

G550

V8 4.0L Turbo				LF ⁴⁵⁰
---------------	--	--	--	-------------------

G63 AMG

V8 5.5 Turbo		VA-452 ¹¹²		
--------------	--	-----------------------	--	--

G65 AMG

V12 6.0				LF
---------	--	--	--	----

GL350 Bluetec

V6 3.0L Diesel Turbo	VO-129			
----------------------	--------	--	--	--

GL450

V6 3.0L Turbo	VO-149			NS
---------------	--------	--	--	----

GL63 AMG

V8 5.5L		VA-452 ¹¹²		NS
---------	--	-----------------------	--	----

GL550

V8 4.6L		VA-452 ¹¹²		
---------	--	-----------------------	--	--

GLA250

4 cyl. 2.0 Turbo	VO-164	VA-449		NS ⁴³⁷
------------------	--------	--------	--	-------------------

GLC300

4 cyl. 2.0 Turbo	VO-164			
------------------	--------	--	--	--

GLE350d

V6 3.0 Diesel Turbo	VO-129			
---------------------	--------	--	--	--

GLE350

V6 3.5L	VO-149	VA-442		LF
---------	--------	--------	--	----

GLE400

V6 3.0 Turbo	VO-149			LF ⁴⁵⁰
--------------	--------	--	--	-------------------

GLE450 AMG

V6 3.0L Turbo	VO-149			LF ⁴⁵⁰
---------------	--------	--	--	-------------------

GLE550e

V6 3.0L Turbo (Hybrid)	VO-149			LF ⁴⁵⁰
------------------------	--------	--	--	-------------------

GLE550

V8 4.6		VA-452 ¹¹²		LF ⁴⁵⁰
--------	--	-----------------------	--	-------------------

GLE63 AMG

V8 5.5 Turbo		VA-452 ¹¹²		LF ⁴⁵⁰
--------------	--	-----------------------	--	-------------------

Metris

4 cyl. 2.0L Turbo	VO-164			NS ⁴³⁷
-------------------	--------	--	--	-------------------

S550

V8 4.6L Turbo	VO-149 ¹⁰⁴⁸	VA-452 ¹¹²		LF ⁴⁵⁰
---------------	------------------------	-----------------------	--	-------------------

S550e

V6 3.0 FI Turbo (Hybrid)	VO-149			LF ⁴⁵⁰
--------------------------	--------	--	--	-------------------

S63 AMG

V8 5.5L Turbo		VA-452 ¹¹²		LF ⁴⁵⁰
---------------	--	-----------------------	--	-------------------

S65 AMG

V12 6.0L Turbo				LF ⁴⁵⁰
----------------	--	--	--	-------------------

SL400

V6 3.0L Turbo	VO-149		VCA-1153	LF ⁴⁵⁰
---------------	--------	--	----------	-------------------

SL550

V8 4.6L Turbo	VO-149 ¹⁰⁴⁸	VA-452 ¹¹²	VCA-1153	LF ⁴⁵⁰
---------------	------------------------	-----------------------	----------	-------------------

SL63 AMG

V8 5.5L Turbo		VA-452 ¹¹²	VCA-1153	LF ⁴⁵⁰
---------------	--	-----------------------	----------	-------------------

Se reporter à table de matière pour les notes en bas de page en français. Utilize el contenido para ver notas a pie.

NS - Non-Serviceable / Non réparable / No reparable LF - Life-Time Filter / Filtro para toda la vida / Filtre à vie

¹¹² Requires two (2). ⁴³⁷ Requires replacement of the complete fuel pump/fuel filter module. ⁴⁵⁰ Lifetime filter. Does not require replacement under normal conditions. ¹⁰⁴⁸ Models requiring filter with stem.



MERCEDES-BENZ (cont'd)

	Oil	Air	Cabin*	Fuel
2016				
SL65 AMG				
V12 6.0L Turbo			VCA-1153	LF ⁴⁵⁰
SLK300				
4 cyl. 2.0L FI	VO-164			NS ⁴³⁷
SLK350				
V6 3.5L FI	VO-149	VA-442		NS ⁴³⁷
Sprinter Van				
4 cyl. 2.1L Diesel Turbo		VA-349	VCA-1142	
V6 3.0L Diesel Turbo	VO-129	VA-349	VCA-1142	
2015				
B250 (Canada)				
4 cyl. 2.0 Turbo	VO-164	VA-449		LF ⁴⁵⁰
C250				
4 cyl. 1.8L Turbo	VO-151	VA-435	VCA-1153	
C300				
4 cyl. 2.0L Turbo	VO-164			NS ⁴³⁷
C350				
V6 3.5L	VO-149	VA-442	VCA-1153	NS ⁴³⁷
C400				
V6 3.0L Turbo	VO-149			
C63 AMG				
V8 4.0L Turbo				LF ⁴⁵⁰
V8 6.2L			VCA-1153	NS ⁴³⁷
CLA250				
4 cyl. 2.0 Turbo	VO-164	VA-449		NS ⁴³⁷
CLS400				
V6 3.0L Turbo	VO-149		VCA-1153	LF ⁴⁵⁰
CLS550				
V8 4.6L Turbo	VO-149 ¹⁰⁴⁸	VA-452 ¹¹²	VCA-1153	LF ⁴³⁷
CLS63 AMG				
V8 5.5L Turbo		VA-452 ¹¹²	VCA-1153	NS ⁴⁵⁰
E250 BlueTec				
4 cyl. 2.1 Diesel Turbo			VCA-1153	
E350				
V6 3.5L	VO-149	VA-442	VCA-1153	NS ⁴³⁷
E400				
V6 3.0L Turbo	VO-149		VCA-1153	NS ⁴³⁷
V6 3.5L - Hybrid	VO-149	VA-442	VCA-1153	
E550				
V8 4.6L FI Turbo	VO-149 ¹⁰⁴⁸	VA-452 ¹¹²	VCA-1153	NS ⁴³⁷
E63 AMG				
V8 5.5L FI Turbo		VA-452 ¹¹²	VCA-1153	LF ⁴⁵⁰
G550				
V8 5.5L	VO-103	VA-132 ¹¹²		LF
G63 AMG				
V8 5.5 Turbo		VA-452		
GL350 Bluetec				
V6 3.0L Diesel Turbo	VO-129			
GL450				
V6 3.0L Turbo	VO-149			NS
GL63 AMG				
V8 5.5L		VA-452 ¹¹²		NS

Se reporter à table de matière pour les notes en bas de page en français. Utilize el contenido para ver notas a pie.

NS - Non-Serviceable / Non réparable / No reparable LF - Life-Time Filter / Filtro para toda la vida / Filtre à vie

¹¹² Requires two (2). ⁴³⁷ Requires replacement of the complete fuel pump/fuel filter module. ⁴⁵⁰ Lifetime filter. Does not require replacement under normal conditions. ¹⁰⁴⁸Models requiring filter with stem.



MERCEDES-BENZ (cont'd)

2015

GL550

V8 4.6L	VO-149 ¹⁰⁴⁸	VA-452 ¹¹²		
---------	------------------------	-----------------------	--	--

GLA250

4 cyl. 2.0 Turbo	VO-164	VA-449		NS ⁴³⁷
------------------	--------	--------	--	-------------------

GLK250 Bluetec

4 cyl. 2.1L Diesel Turbo			VCA-1153	
--------------------------	--	--	----------	--

GLK350

V6 3.5L	VO-149	VA-442 ¹¹²	VCA-1153	LF ⁴⁵⁰
---------	--------	-----------------------	----------	-------------------

ML350

V6 3.5L	VO-149	VA-442 ¹¹²		NS
---------	--------	-----------------------	--	----

ML350 Bluetec

V6 3.0L Diesel Turbo	VO-129			
----------------------	--------	--	--	--

ML400

V6 3.0L Turbo	VO-149			NS
---------------	--------	--	--	----

ML550

V8 4.6L Turbo	VO-149 ¹⁰⁴⁸	VA-452 ¹¹²		
---------------	------------------------	-----------------------	--	--

ML63 AMG

V8 5.5L Turbo		VA-452 ¹¹²		LF ⁴⁵⁰
---------------	--	-----------------------	--	-------------------

S550

V8 4.6L Turbo	VO-149 ¹⁰⁴⁸	VA-452 ¹¹²		LF ⁴⁵⁰
---------------	------------------------	-----------------------	--	-------------------

S550e

V6 3.0 FI Turbo (Hybrid)	VO-149			LF ⁴⁵⁰
--------------------------	--------	--	--	-------------------

S63 AMG

V8 5.5L Turbo		VA-452 ¹¹²		LF ⁴⁵⁰
---------------	--	-----------------------	--	-------------------

S65 AMG

V12 6.0L Turbo				LF ⁴⁵⁰
----------------	--	--	--	-------------------

SL400

V6 3.0L Turbo	VO-149		VCA-1153	LF ⁴⁵⁰
---------------	--------	--	----------	-------------------

SL550

V8 4.6L Turbo	VO-149 ¹⁰⁴⁸	VA-452 ¹¹²	VCA-1153	LF ⁴⁵⁰
---------------	------------------------	-----------------------	----------	-------------------

SL63 AMG

V8 5.5L Turbo		VA-452 ¹¹²	VCA-1153	LF ⁴⁵⁰
---------------	--	-----------------------	----------	-------------------

SL65 AMG

V12 6.0L Turbo			VCA-1153	LF ⁴⁵⁰
----------------	--	--	----------	-------------------

SLK250

4 cyl 1.8L FI Turbo	VO-151	VA-435		
---------------------	--------	--------	--	--

SLK350

V6 3.5L FI	VO-149	VA-442		NS ⁴³⁷
------------	--------	--------	--	-------------------

SLS AMG

V8 6.3L			VCA-1153	LF ⁴⁵⁰
---------	--	--	----------	-------------------

Sprinter Van

4 cyl. 2.1L Diesel Turbo		VA-349	VCA-1142	
--------------------------	--	--------	----------	--

V6 3.0L Diesel Turbo	VO-129	VA-349	VCA-1142	
----------------------	--------	--------	----------	--

2014

B250 (Canada)

4 cyl. 2.0 Turbo	VO-164	VA-449		LF ⁴⁵⁰
------------------	--------	--------	--	-------------------

C250

4 cyl. 1.8L Turbo	VO-151	VA-435	VCA-1153	
-------------------	--------	--------	----------	--

C300

V6 3.5L	VO-149	VA-442	VCA-1153	NS ⁴³⁷
---------	--------	--------	----------	-------------------

C350

V6 3.5L	VO-149	VA-442	VCA-1153	NS ⁴³⁷
---------	--------	--------	----------	-------------------

Se reporter à table de matière pour les notes en bas de page en français. Utilize el contenido para ver notas a pie.

NS - Non-Serviceable / Non réparable / No reparable LF - Life-Time Filter / Filtro para toda la vida / Filtre à vie

¹¹² Requires two (2). ⁴³⁷ Requires replacement of the complete fuel pump/fuel filter module. ⁴⁵⁰ Lifetime filter. Does not require replacement under normal conditions. ¹⁰⁴⁸ Models requiring filter with stem.



MERCEDES-BENZ (cont'd)

Model	Oil	Air	Cabin*	Fuel
2014				
C63 AMG				
V8 6.2L			VCA-1153	NS ⁴³⁷
CL550				
V8 4.6L FI Turbo	VO-149 ¹⁰⁴⁸	VA-452 ¹¹²		NS ⁴³⁷
CL63 AMG				
V8 5.5L Turbo		VA-452 ¹¹²		LF ⁴⁵⁰
CL65 AMG				
V12 6.0L Turbo				LF ⁴⁵⁰
CL600				
V12 5.5L FI Turbo				LF ⁴⁵⁰
CLA250				
4 cyl. 2.0 Turbo	VO-164	VA-449		NS ⁴³⁷
CLS550				
V8 4.6L Turbo	VO-149 ¹⁰⁴⁸	VA-452 ¹¹²	VCA-1153	LF ⁴³⁷
CLS63 AMG				
V8 5.5L Turbo		VA-452 ¹¹²	VCA-1153	NS ⁴⁵⁰
E250 BlueTec				
4 cyl. 2.1 Diesel Turbo			VCA-1153	
E350				
V6 3.5L	VO-149	VA-442	VCA-1153	NS ⁴³⁷
E400				
V6 3.5L - Hybrid	VO-149	VA-442	VCA-1153	
E550				
V8 4.6L FI Turbo	VO-149 ¹⁰⁴⁸	VA-452 ¹¹²	VCA-1153	NS ⁴³⁷
E63 AMG				
V8 5.5L FI Turbo		VA-452 ¹¹²	VCA-1153	LF ⁴⁵⁰
G550				
V8 5.5L	VO-103	VA-132 ¹¹²		LF ⁴⁵⁰
G63 AMG				
V8 5.5 Turbo		VA-452 ¹¹²		
GL350 Bluetec				
V6 3.0L Diesel Turbo	VO-129			
GL450				
V8 4.6L	VO-149	VA-452 ¹¹²		NS ⁴³⁷
GL63 AMG				
V8 5.5L		VA-452 ¹¹²		
GL550				
V8 4.6L	VO-149	VA-452 ¹¹²		
GLK250 Bluetec				
4 cyl. 2.1L Diesel Turbo			VCA-1153	
GLK350				
V6 3.5L	VO-149	VA-442 ¹¹²	VCA-1153	LF ⁴⁵⁰
ML350				
V6 3.5L	VO-149	VA-442 ¹¹²		NS ⁴³⁷
ML350 Bluetec				
V6 3.0L Diesel Turbo	VO-129			
ML550				
V8 4.6L Turbo	VO-149 ¹⁰⁴⁸	VA-452 ¹¹²		
ML63 AMG				
V8 5.5L Turbo		VA-452 ¹¹²		LF ⁴⁵⁰
S550				
V8 4.6L Turbo	VO-149 ¹⁰⁴⁸	VA-452 ¹¹²		LF ⁴⁵⁰

Se reporter à table de matière pour les notes en bas de page en français. Utilize el contenido para ver notas a pie.

NS - Non-Serviceable / Non réparable / No reparable LF - Life-Time Filter / Filtro para toda la vida / Filtre à vie

¹¹² Requires two (2). ⁴³⁷ Requires replacement of the complete fuel pump/fuel filter module. ⁴⁵⁰ Lifetime filter. Does not require replacement under normal conditions. ¹⁰⁴⁸Models requiring filter with stem.



MERCEDES-BENZ (cont'd)

2014

S63 AMG

V8 5.5L Turbo		VA-452 ¹¹²		LF ⁴⁵⁰
---------------	--	-----------------------	--	-------------------

SL550

V8 4.6L Turbo	VO-149 ¹⁰⁴⁸	VA-452 ¹¹²	VCA-1153	LF ⁴⁵⁰
---------------	------------------------	-----------------------	----------	-------------------

SL63 AMG

V8 5.5L Turbo		VA-452 ¹¹²	VCA-1153	LF ⁴⁵⁰
---------------	--	-----------------------	----------	-------------------

SL65 AMG

V12 6.0L Turbo			VCA-1153	LF ⁴⁵⁰
----------------	--	--	----------	-------------------

SLK250

4 cyl 1.8L FI Turbo	VO-151	VA-435		
---------------------	--------	--------	--	--

SLK350

V6 3.5L FI	VO-149	VA-442		NS ⁴³⁷
------------	--------	--------	--	-------------------

SLS AMG

V8 6.3L			VCA-1153	LF ⁴⁵⁰
---------	--	--	----------	-------------------

Sprinter Van

4 cyl. 2.1L Diesel Turbo		VA-349	VCA-1142	
--------------------------	--	--------	----------	--

V6 3.0L Diesel Turbo	VO-129	VA-349	VCA-1142	
----------------------	--------	--------	----------	--

2013

B250 (Canada)

4 cyl. 2.0 Turbo	VO-164	VA-449		LF ⁴⁵⁰
------------------	--------	--------	--	-------------------

C250

4 cyl. 1.8L Turbo	VO-151	VA-435	VCA-1153	
-------------------	--------	--------	----------	--

C300

V6 3.5L	VO-149	VA-442	VCA-1153	NS ⁴³⁷
---------	--------	--------	----------	-------------------

C350

V6 3.5L	VO-149	VA-442	VCA-1153	NS ⁴³⁷
---------	--------	--------	----------	-------------------

C63 AMG

V8 6.2L			VCA-1153	NS ⁴³⁷
---------	--	--	----------	-------------------

CL550

V8 4.6L FI Turbo	VO-149 ¹⁰⁴⁸	VA-452 ¹¹²		NS ⁴³⁷
------------------	------------------------	-----------------------	--	-------------------

CL63 AMG

V8 5.5L Turbo		VA-452 ¹¹²		LF ⁴⁵⁰
---------------	--	-----------------------	--	-------------------

CL65 AMG

V12 6.0L Turbo				LF ⁴⁵⁰
----------------	--	--	--	-------------------

CL600

V12 5.5L FI Turbo				LF ⁴⁵⁰
-------------------	--	--	--	-------------------

CLS550

V8 4.6L Turbo	VO-149 ¹⁰⁴⁸	VA-452 ¹¹²	VCA-1153	LF ⁴³⁷
---------------	------------------------	-----------------------	----------	-------------------

CLS63 AMG

V8 5.5L Turbo		VA-452 ¹¹²	VCA-1153	NS ⁴⁵⁰
---------------	--	-----------------------	----------	-------------------

E350 Bluetec

V6 3.0L Diesel Turbo	VO-129	VA-371	VCA-1153	
----------------------	--------	--------	----------	--

E350

V6 3.5L	VO-149	VA-442	VCA-1153	NS ⁴³⁷
---------	--------	--------	----------	-------------------

E400

V6 3.5L - Hybrid	VO-149	VA-442	VCA-1153	
------------------	--------	--------	----------	--

E550

V8 4.6L FI Turbo	VO-149 ¹⁰⁴⁸	VA-452 ¹¹²	VCA-1153	NS ⁴³⁷
------------------	------------------------	-----------------------	----------	-------------------

E63 AMG

V8 5.5L FI Turbo		VA-452 ¹¹²		LF ⁴⁵⁰
------------------	--	-----------------------	--	-------------------

G550

V8 5.5L	VO-103	VA-132 ¹¹²		LF ⁴⁵⁰
---------	--------	-----------------------	--	-------------------

Se reporter à table de matière pour les notes en bas de page en français. Utilize el contenido para ver notas a pie.

NS - Non-Serviceable / Non réparable / No reparable LF - Life-Time Filter / Filtro para toda la vida / Filtre à vie

¹¹² Requires two (2). ⁴³⁷ Requires replacement of the complete fuel pump/fuel filter module. ⁴⁵⁰ Lifetime filter. Does not require replacement under normal conditions. ¹⁰⁴⁸ Models requiring filter with stem.



MERCEDES-BENZ (cont'd)

	Oil	Air	Cabin*	Fuel
2013				
G63 AMG				
V8 5.5 Turbo		VA-452 ¹¹²		
GL350 Bluetec				
V6 3.0L Diesel Turbo	VO-129			
GL450				
V8 4.6L	VO-149	VA-452 ¹¹²		NS ⁴³⁷
GL63 AMG				
V8 5.5L		VA-452 ¹¹²		
GL550				
V8 4.6L	VO-149	VA-452 ¹¹²		
GLK250 Bluetec				
4 cyl. 2.1L Diesel Turbo			VCA-1153	
GLK350				
V6 3.5L	VO-149	VA-442 ¹¹²	VCA-1153	LF ⁴⁵⁰
ML350				
V6 3.5L	VO-149	VA-442 ¹¹²		NS ⁴³⁷
ML350 Bluetec				
V6 3.0L Diesel Turbo	VO-129			
ML550				
V8 4.6L Turbo	VO-149 ¹⁰⁴⁸	VA-452 ¹¹²		
ML63 AMG				
V8 5.5L Turbo		VA-452 ¹¹²		LF ⁴⁵⁰
R350				
V6 3.5L	VO-149	VA-452 ¹¹²		NS ⁴³⁷
R350 Bluetec				
V6 3.0L Diesel Turbo	VO-129	VA-371		
S350 Bluetec				
V6 3.0L Diesel Turbo	VO-129			
S400				
V6 3.5L Hybrid	VO-103	VA-132 ¹¹²		NS ⁴³⁷
S550				
V8 4.6L Turbo	VO-149 ¹⁰⁴⁸	VA-452 ¹¹²		LF ⁴⁵⁰
S63 AMG				
V8 5.5L Turbo		VA-452 ¹¹²		LF ⁴⁵⁰
S65 AMG				
V12 6.0L Turbo				LF ⁴⁵⁰
SL550				
V8 4.6L Turbo	VO-149 ¹⁰⁴⁸	VA-452 ¹¹²	VCA-1153	LF ⁴⁵⁰
SL63 AMG				
V8 5.5L Turbo		VA-452 ¹¹²	VCA-1153	LF ⁴⁵⁰
SL65 AMG				
V12 6.0L Turbo				LF ⁴⁵⁰
SLK250				
4 cyl 1.8L FI Turbo	VO-151	VA-435		
SLK350				
V6 3.5L FI	VO-149	VA-442		NS ⁴³⁷
SLS AMG				
V8 6.3L			VCA-1153	LF ⁴⁵⁰
Sprinter Van				
V6 3.0L Diesel Turbo	VO-129	VA-349	VCA-1142	

Se reporter à table de matière pour les notes en bas de page en français. Utilize el contenido para ver notas a pie.

NS - Non-Serviceable / Non réparable / No reparable LF - Life-Time Filter / Filtro para toda la vida / Filtre à vie

¹¹² Requires two (2). ⁴³⁷ Requires replacement of the complete fuel pump/fuel filter module. ⁴⁵⁰ Lifetime filter. Does not require replacement under normal conditions. ¹⁰⁴⁸Models requiring filter with stem.



MERCEDES-BENZ (cont'd)

2012

C250

4 cyl. 1.8L Turbo	VO-151	VA-435	VCA-1153	
-------------------	--------	--------	----------	--

C250 (Canada)

V6 2.5L	VO-103	VA-132	VCA-1153	NS ⁴³⁷
---------	--------	--------	----------	-------------------

C300

V6 3.0L	VO-103	VA-132 ¹¹²	VCA-1153	NS ⁴³⁷
---------	--------	-----------------------	----------	-------------------

C350

V6 3.5L	VO-149	VA-442	VCA-1153	NS ⁴³⁷
---------	--------	--------	----------	-------------------

C63 AMG

V8 6.2L			VCA-1153	NS ⁴³⁷
---------	--	--	----------	-------------------

CL550

V8 4.6L FI Turbo	VO-149 ¹⁰⁴⁸	VA-452 ¹¹²		NS ⁴³⁷
------------------	------------------------	-----------------------	--	-------------------

CL63 AMG

V8 5.5L Turbo		VA-452 ¹¹²		LF ⁴⁵⁰
---------------	--	-----------------------	--	-------------------

CL65 AMG

V12 6.0L Turbo				LF ⁴⁵⁰
----------------	--	--	--	-------------------

CL600

V12 5.5L FI Turbo				LF ⁴⁵⁰
-------------------	--	--	--	-------------------

CLS550

V8 4.6L Turbo	VO-149 ¹⁰⁴⁸	VA-452 ¹¹²	VCA-1153	LF ⁴³⁷
---------------	------------------------	-----------------------	----------	-------------------

CLS63 AMG

V8 5.5L Turbo		VA-452 ¹¹²	VCA-1153	NS ⁴⁵⁰
---------------	--	-----------------------	----------	-------------------

E350 Bluetec

V6 3.0L Diesel Turbo	VO-129	VA-371	VCA-1153	
----------------------	--------	--------	----------	--

E350

V6 3.5L	VO-149	VA-442	VCA-1153	NS ⁴³⁷
---------	--------	--------	----------	-------------------

E550

V8 4.6L FI Turbo	VO-149 ¹⁰⁴⁸	VA-452 ¹¹²	VCA-1153	NS ⁴³⁷
------------------	------------------------	-----------------------	----------	-------------------

E63 AMG

V8 5.5L FI Turbo		VA-452 ¹¹²		LF ⁴⁵⁰
------------------	--	-----------------------	--	-------------------

G550

V8 5.5L	VO-103	VA-132 ¹¹²		LF ⁴⁵⁰
---------	--------	-----------------------	--	-------------------

GL350 Bluetec

V6 3.0L Diesel Turbo	VO-129	VA-371		
----------------------	--------	--------	--	--

GL450

V8 4.6L	VO-103	VA-132 ¹¹²		NS ⁴³⁷
---------	--------	-----------------------	--	-------------------

GL550

V8 5.5L	VO-103	VA-132 ¹¹²		NS ⁴³⁷
---------	--------	-----------------------	--	-------------------

GLK350

V6 3.5L	VO-103	VA-132 ¹¹²	VCA-1153	LF ⁴⁵⁰
---------	--------	-----------------------	----------	-------------------

ML350

V6 3.5L	VO-149	VA-132 ¹¹²		NS ⁴³⁷
---------	--------	-----------------------	--	-------------------

ML350 Bluetec

V6 3.0L Diesel Turbo	VO-129			
----------------------	--------	--	--	--

ML550

V8 4.6L Turbo	VO-149 ¹⁰⁴⁸	VA-452		
---------------	------------------------	--------	--	--

ML63 AMG

V8 5.5L Turbo		VA-452 ¹¹²		LF ⁴⁵⁰
---------------	--	-----------------------	--	-------------------

R350

V6 3.5L	VO-149	VA-452 ¹¹²		NS ⁴³⁷
---------	--------	-----------------------	--	-------------------

R350 Bluetec

V6 3.0L Diesel Turbo	VO-129	VA-371		
----------------------	--------	--------	--	--

Se reporter à table de matière pour les notes en bas de page en français. Utilize el contenido para ver notas a pie.

NS - Non-Serviceable / Non réparable / No reparable LF - Life-Time Filter / Filtro para toda la vida / Filtre à vie

¹¹² Requires two (2). ⁴³⁷ Requires replacement of the complete fuel pump/fuel filter module. ⁴⁵⁰ Lifetime filter. Does not require replacement under normal conditions. ¹⁰⁴⁸ Models requiring filter with stem.



MERCEDES-BENZ (cont'd)

	Oil	Air	Cabin*	Fuel
2012				
S350 Bluetec				
V6 3.0L Diesel Turbo	VO-129			
S400				
V6 3.5L Hybrid	VO-103	VA-132 ¹¹²		NS ⁴³⁷
S550				
V8 4.6L Turbo	VO-149 ¹⁰⁴⁸	VA-452 ¹¹²		LF ⁴⁵⁰
S63 AMG				
V8 5.5L Turbo		VA-452 ¹¹²		LF ⁴⁵⁰
S65 AMG				
V12 6.0L Turbo				LF ⁴⁵⁰
SL550				
V8 5.5L FI	VO-103	VA-132 ¹¹²		
SL63 AMG				
V8 6.3L FI				LF ⁴⁵⁰
SLK250				
4 cyl 1.8L FI Turbo	VO-151	VA-435		
SLK350				
V6 3.5L FI	VO-149	VA-442		NS ⁴³⁷
SLS AMG				
V8 6.3L			VCA-1153	LF ⁴⁵⁰
Sprinter Van				
V6 3.0L Diesel Turbo	VO-129	VA-349	VCA-1142	
2011				
C250 (Canada)				
V6 2.5L	VO-103	VA-132	VCA-1153	NS ⁴³⁷
C300				
V6 3.0L	VO-103	VA-132 ¹¹²	VCA-1153	NS ⁴³⁷
C350				
V6 3.5L	VO-103	VA-132 ¹¹²	VCA-1153	NS ⁴³⁷
C63 AMG				
V8 6.2L			VCA-1153	NS ⁴³⁷
CL550				
V8 4.6L FI Turbo	VO-149	VA-452 ¹¹²		NS ⁴³⁷
CL63 AMG				
V8 5.5L Turbo		VA-452 ¹¹²		LF ⁴⁵⁰
CLS550				
V8 5.5L FI	VO-103	VA-132 ¹¹²		LF ⁴⁵⁰
E350 Bluetec				
V6 3.0L Diesel Turbo	VO-129	VA-371	VCA-1153	
E350				
V6 3.5L	VO-103	VA-132 ¹¹²		NS ⁴³⁷
E550				
V8 5.5L FI	VO-103	VA-132 ¹¹²		
E63 AMG				
V8 6.3L FI				LF ⁴⁵⁰
G55				
V8 5.5L FI (S.C.)	VO-103			
G550				
V8 5.5L	VO-103	VA-132 ¹¹²		LF ⁴⁵⁰
GL350 Bluetec				
V6 3.0L Diesel Turbo	VO-129	VA-371		

Se reporter à table de matière pour les notes en bas de page en français. Utilize el contenido para ver notas a pie.

NS - Non-Serviceable / Non réparable / No reparable LF - Life-Time Filter / Filtro para toda la vida / Filtre à vie

¹¹² Requires two (2). ⁴³⁷ Requires replacement of the complete fuel pump/fuel filter module. ⁴⁵⁰ Lifetime filter. Does not require replacement under normal conditions. ¹⁰⁴⁸ Models requiring filter with stem.



MERCEDES-BENZ (cont'd)

2011

GL450

V8 4.6L	VO-103	VA-132 ¹¹²		NS ⁴³⁷
---------	--------	-----------------------	--	-------------------

GL550

V8 5.5L	VO-103	VA-132 ¹¹²		NS ⁴³⁷
---------	--------	-----------------------	--	-------------------

GLK350

V6 3.5L	VO-103	VA-132 ¹¹²	VCA-1153	LF ⁴⁵⁰
---------	--------	-----------------------	----------	-------------------

ML350

V6 3.5L	VO-103	VA-132 ¹¹²		NS ⁴³⁷
---------	--------	-----------------------	--	-------------------

ML350 Bluetec

V6 3.0L Diesel Turbo	VO-129	VA-371		
----------------------	--------	--------	--	--

ML450h

V6 3.5L Hybrid	VO-103	VA-132 ¹¹²		LF ⁴⁵⁰
----------------	--------	-----------------------	--	-------------------

ML550

V8 5.5L	VO-103	VA-132 ¹¹²		NS ⁴³⁷
---------	--------	-----------------------	--	-------------------

ML63 AMG

V8 6.2L				LF ⁴⁵⁰
---------	--	--	--	-------------------

R350

V6 3.5L	VO-103	VA-132 ¹¹²		NS ⁴³⁷
---------	--------	-----------------------	--	-------------------

R350 Bluetec

V6 3.0L Diesel Turbo	VO-129	VA-371		
----------------------	--------	--------	--	--

S400

V6 3.5L Hybrid	VO-103	VA-132 ¹¹²		NS ⁴³⁷
----------------	--------	-----------------------	--	-------------------

S450 (Canada)

V8 4.6L FI	VO-103	VA-132 ¹¹²		LF ⁴⁵⁰
------------	--------	-----------------------	--	-------------------

S550

V8 5.5L FI	VO-103	VA-132 ¹¹²		LF ⁴⁵⁰
------------	--------	-----------------------	--	-------------------

S63 AMG

V8 5.5L Turbo		VA-452 ¹¹²		LF ⁴⁵⁰
---------------	--	-----------------------	--	-------------------

S65 AMG

V12 6.0L Turbo				LF ⁴⁵⁰
----------------	--	--	--	-------------------

SL550

V8 5.5L FI	VO-103	VA-132 ¹¹²		
------------	--------	-----------------------	--	--

SL63 AMG

V8 6.3L FI				LF ⁴⁵⁰
------------	--	--	--	-------------------

SL65 AMG

V12 6.0L Turbo				LF ⁴⁵⁰
----------------	--	--	--	-------------------

SLK300

V6 3.0L FI	VO-103	VA-132 ¹¹²		NS ⁴³⁷
------------	--------	-----------------------	--	-------------------

SLK350

V6 3.5L FI	VO-103	VA-132 ¹¹²		NS ⁴³⁷
------------	--------	-----------------------	--	-------------------

SLK55 AMG

V8 5.5L		VA-132 ¹¹²		NS ⁴³⁷
---------	--	-----------------------	--	-------------------

SLS AMG

V8 6.3L			VCA-1153	LF ⁴⁵⁰
---------	--	--	----------	-------------------

Sprinter Van

V6 3.0L Diesel Turbo	VO-129	VA-349	VCA-1142	
----------------------	--------	--------	----------	--

2010

C250 (Canada)

V6 2.5L	VO-103	VA-132	VCA-1153	NS ⁴³⁷
---------	--------	--------	----------	-------------------

C300

V6 3.0L	VO-103	VA-132 ¹¹²	VCA-1153	NS ⁴³⁷
---------	--------	-----------------------	----------	-------------------

Se reporter à table de matière pour les notes en bas de page en français. Utilize el contenido para ver notas a pie.

NS - Non-Serviceable / Non réparable / No repairable LF - Life-Time Filter / Filtro para toda la vida / Filtre à vie

¹¹² Requires two (2). ⁴³⁷ Requires replacement of the complete fuel pump/fuel filter module. ⁴⁵⁰ Lifetime filter. Does not require replacement under normal conditions.



MERCEDES-BENZ (cont'd)

	Oil	Air	Cabin*	Fuel
2010				
C350				
V6 3.5L	VO-103	VA-132 ¹¹²	VCA-1153	NS ⁴³⁷
C63 AMG				
V8 6.2L			VCA-1153	NS ⁴³⁷
CL550				
V8 5.5L FI	VO-103	VA-132 ¹¹²		LF ⁴⁵⁰
CL63 AMG				
V8 6.3L				LF ⁴⁵⁰
CLS550				
V8 5.5L FI	VO-103	VA-132 ¹¹²		LF ⁴⁵⁰
E350				
V6 3.5L FI	VO-103	VA-132 ¹¹²		NS ⁴³⁷
E550				
V8 5.5L FI	VO-103	VA-132 ¹¹²		
E63 AMG				
V8 6.3L FI				LF ⁴⁵⁰
G55				
V8 5.5L FI (S.C.)	VO-103			
G550				
V8 5.5L	VO-103	VA-132 ¹¹²		LF ⁴⁵⁰
GL350 Bluetec				
V6 3.0L Diesel Turbo	VO-129	VA-371		
GL450				
V8 4.6L	VO-103	VA-132 ¹¹²		NS ⁴³⁷
GL550				
V8 5.5L	VO-103	VA-132 ¹¹²		NS ⁴³⁷
GLK350				
V6 3.5L	VO-103	VA-132 ¹¹²	VCA-1153	LF ⁴⁵⁰
ML350				
V6 3.5L	VO-103	VA-132 ¹¹²		NS ⁴³⁷
ML350 Bluetec				
V6 3.0L Diesel Turbo	VO-129	VA-371		
ML450h				
V6 3.5L Hybrid	VO-103	VA-132 ¹¹²		LF ⁴⁵⁰
ML550				
V8 5.5L	VO-103	VA-132 ¹¹²		NS ⁴³⁷
ML63 AMG				
V8 6.2L				LF ⁴⁵⁰
R350				
V6 3.5L	VO-103	VA-132 ¹¹²		NS ⁴³⁷
R350 Bluetec				
V6 3.0L Diesel Turbo	VO-129	VA-371		
S400				
V6 3.5L Hybrid	VO-103	VA-132 ¹¹²		NS ⁴³⁷
S450 (Canada)				
V8 4.6L FI	VO-103	VA-132 ¹¹²		LF ⁴⁵⁰
S550				
V8 5.5L FI	VO-103	VA-132 ¹¹²		LF ⁴⁵⁰
S63 AMG				
V8 6.3L FI				LF ⁴⁵⁰
S65 AMG				
V12 6.0L Turbo				LF ⁴⁵⁰

Se reporter à table de matière pour les notes en bas de page en français. Utilize el contenido para ver notas a pie.

NS - Non-Serviceable / Non réparable / No reparable LF - Life-Time Filter / Filtro para toda la vida / Filtre à vie

¹¹² Requires two (2). ⁴³⁷ Requires replacement of the complete fuel pump/fuel filter module. ⁴⁵⁰ Lifetime filter. Does not require replacement under normal conditions.



MERCEDES-BENZ (cont'd)

2010

SL550

V8 5.5L FI	VO-103	VA-132 ¹¹²		
------------	--------	-----------------------	--	--

SL63 AMG

V8 6.3L FI				LF ⁴⁵⁰
------------	--	--	--	-------------------

SL65 AMG

V12 6.0L Turbo				LF ⁴⁵⁰
----------------	--	--	--	-------------------

SLK300

V6 3.0L FI	VO-103	VA-132 ¹¹²		NS ⁴³⁷
------------	--------	-----------------------	--	-------------------

SLK350

V6 3.5L FI	VO-103	VA-132 ¹¹²		NS ⁴³⁷
------------	--------	-----------------------	--	-------------------

SLK55 AMG

V8 5.5L		VA-132 ¹¹²		NS ⁴³⁷
---------	--	-----------------------	--	-------------------

Sprinter Van

V6 3.0L Diesel Turbo	VO-129	VA-349	VCA-1142	
----------------------	--------	--------	----------	--

2009

C230

V6 2.5L FI	VO-103	VA-132	VCA-1153	NS ⁴³⁷
------------	--------	--------	----------	-------------------

C300

V6 3.0L	VO-103	VA-132 ¹¹²	VCA-1153	NS ⁴³⁷
---------	--------	-----------------------	----------	-------------------

C350

V6 3.5L	VO-103	VA-132 ¹¹²	VCA-1153	NS ⁴³⁷
---------	--------	-----------------------	----------	-------------------

C63 AMG

V8 6.2L			VCA-1153	NS ⁴³⁷
---------	--	--	----------	-------------------

CL550

V8 5.5L FI	VO-103	VA-132 ¹¹²		LF ⁴⁵⁰
------------	--------	-----------------------	--	-------------------

CL63 AMG

V8 6.3L				LF ⁴⁵⁰
---------	--	--	--	-------------------

CLK350

V6 3.5L FI	VO-103	VA-132 ¹¹²	VCA-1106 ^{X135} VCA-1126 ^{Z135}	NS ⁴³⁷
------------	--------	-----------------------	--	-------------------

CLK550

V8 5.5L FI	VO-103	VA-132 ¹¹²	VCA-1106 ^{X135} VCA-1126 ^{Z135}	
------------	--------	-----------------------	--	--

CLK63 AMG

V8 6.2L FI			VCA-1106 ^{X135} VCA-1126 ^{Z135}	LF ⁴⁵⁰
------------	--	--	--	-------------------

CLS550

V8 5.5L FI	VO-103	VA-132 ¹¹²		LF ⁴⁵⁰
------------	--------	-----------------------	--	-------------------

E320 Bluetec

V6 3.0L DI Turbo Diesel	VO-129	VA-371 ¹¹²		
-------------------------	--------	-----------------------	--	--

E350

V6 3.5L FI	VO-103	VA-132 ¹¹²		NS ⁴³⁷
------------	--------	-----------------------	--	-------------------

E550

V8 5.5L FI	VO-103	VA-132 ¹¹²		
------------	--------	-----------------------	--	--

E63 AMG

V8 6.3L FI				LF ⁴⁵⁰
------------	--	--	--	-------------------

G55

V8 5.5L FI (S.C.)	VO-103			
-------------------	--------	--	--	--

G550

V8 5.5L	VO-103	VA-132 ¹¹²		LF ⁴⁵⁰
---------	--------	-----------------------	--	-------------------

GL320 Bluetec

V6 3.0L Diesel Turbo	VO-129	VA-371		
----------------------	--------	--------	--	--

Se reporter à table de matière pour les notes en bas de page en français. Utilize el contenido para ver notas a pie.

NS - Non-Serviceable / Non réparable / No reparable LF - Life-Time Filter / Filtro para toda la vida / Filtre à vie

¹¹² Requires two (2). ⁴³⁷ Requires replacement of the complete fuel pump/fuel filter module. ⁴⁵⁰ Lifetime filter. Does not require replacement under normal conditions. ^{X135}Dust filter serviced under hood. ^{Z135}Dust and odor filter serviced under glove box.



MERCEDES-BENZ (cont'd)

	Oil	Air	Cabin*	Fuel
2009				
GL450				
V8 4.6L	VO-103	VA-132 ¹¹²		NS ⁴³⁷
GL550				
V8 5.5L	VO-103	VA-132 ¹¹²		NS ⁴³⁷
ML320 Bluetec				
V6 3.0L Diesel Turbo	VO-129	VA-371 ¹¹²		
ML350				
V6 3.5L	VO-103	VA-132 ¹¹²		NS ⁴³⁷
ML550				
V8 5.5L	VO-103	VA-132 ¹¹²		NS ⁴³⁷
ML63 AMG				
V8 6.2L				LF ⁴⁵⁰
R320 Bluetec				
V6 3.0L Diesel Turbo	VO-129	VA-371 ¹¹²		
R350				
V6 3.5L	VO-103	VA-132 ¹¹²		NS ⁴³⁷
S450 (Canada)				
V8 4.6L FI	VO-103	VA-132 ¹¹²		LF ⁴⁵⁰
S550				
V8 5.5L FI	VO-103	VA-132 ¹¹²		LF ⁴⁵⁰
S63 AMG				
V8 6.3L FI				LF ⁴⁵⁰
S65 AMG				
V12 6.0L Turbo				LF ⁴⁵⁰
SL550				
V8 5.5L FI	VO-103	VA-132 ¹¹²		
SL63 AMG				
V8 6.3L FI				LF ⁴⁵⁰
SL65 AMG				
V12 6.0L Turbo				LF ⁴⁵⁰
SLK300				
V6 3.0L FI	VO-103	VA-132 ¹¹²		NS ⁴³⁷
SLK350				
V6 3.5L FI	VO-103	VA-132 ¹¹²		NS ⁴³⁷
SLK55 AMG				
V8 5.5L		VA-132 ¹¹²		NS ⁴³⁷
2008				
C230				
V6 2.5L FI	VO-103	VA-132	VCA-1106 ^{X135} VCA-1126 ^{Z135}	NS ⁴³⁷
C300				
V6 3.0L	VO-103	VA-132 ¹¹²	VCA-1153	NS ⁴³⁷
C350				
V6 3.5L	VO-103	VA-132 ¹¹²	VCA-1153	NS ⁴³⁷
C63 AMG				
V8 6.2L			VCA-1153	NS ⁴³⁷
CL550				
V8 5.5L FI	VO-103	VA-132 ¹¹²		LF ⁴⁵⁰
CL63 AMG				
V8 6.3L				LF ⁴⁵⁰

Se reporter à table de matière pour les notes en bas de page en français. Utilize el contenido para ver notas a pie.

NS - Non-Serviceable / Non réparable / No reparable LF - Life-Time Filter / Filtro para toda la vida / Filtre à vie

¹¹² Requires two (2). ⁴³⁷ Requires replacement of the complete fuel pump/fuel filter module. ⁴⁵⁰ Lifetime filter. Does not require replacement under normal conditions. ^{X135}Dust filter serviced under hood. ^{Z135}Dust and odor filter serviced under glove box.



MERCEDES-BENZ (cont'd)

2008

CLK350

V6 3.5L FI	VO-103	VA-132 ¹¹²	VCA-1106 ^{X135} VCA-1126 ^{Z135}	NS ⁴³⁷
------------	--------	-----------------------	--	-------------------

CLK550

V8 5.5L FI	VO-103	VA-132 ¹¹²	VCA-1106 ^{X135} VCA-1126 ^{Z135}	
------------	--------	-----------------------	--	--

CLK63 AMG

V8 6.2L FI			VCA-1106 ^{X135} VCA-1126 ^{Z135}	LF ⁴⁵⁰
------------	--	--	--	-------------------

CLS550

V8 5.5L FI	VO-103	VA-132 ¹¹²		LF ⁴⁵⁰
------------	--------	-----------------------	--	-------------------

E280

V6 3.0L FI (Mexico)	VO-103	VA-132 ¹¹²		NS ⁴³⁷
---------------------	--------	-----------------------	--	-------------------

E320 Bluetec

V6 3.0L DI Turbo Diesel	VO-129	VA-371 ¹¹²		
-------------------------	--------	-----------------------	--	--

E350

V6 3.5L FI	VO-103	VA-132 ¹¹²		NS ⁴³⁷
------------	--------	-----------------------	--	-------------------

E550

V8 5.5L FI	VO-103	VA-132 ¹¹²		
------------	--------	-----------------------	--	--

E63 AMG

V8 6.3L FI				LF ⁴⁵⁰
------------	--	--	--	-------------------

G500

V8 5.0L FI	VO-103	VA-132 ¹¹²		
------------	--------	-----------------------	--	--

G55

V8 5.5L FI (S.C.)	VO-103			
-------------------	--------	--	--	--

GL320 CDI

V6 3.0L Diesel Turbo	VO-129	VA-371 ¹¹²		
----------------------	--------	-----------------------	--	--

GL450

V8 4.6L	VO-103	VA-132 ¹¹²		NS ⁴³⁷
---------	--------	-----------------------	--	-------------------

GL550

V8 5.5L	VO-103	VA-132 ¹¹²		NS ⁴³⁷
---------	--------	-----------------------	--	-------------------

ML320 CDI

V6 3.0L Diesel Turbo	VO-129	VA-371 ¹¹²		
----------------------	--------	-----------------------	--	--

ML350

V6 3.5L	VO-103	VA-132 ¹¹²		NS ⁴³⁷
---------	--------	-----------------------	--	-------------------

ML550

V8 5.5L	VO-103	VA-132 ¹¹²		NS ⁴³⁷
---------	--------	-----------------------	--	-------------------

ML63 AMG

V8 6.2L				LF ⁴⁵⁰
---------	--	--	--	-------------------

R320 CDI

V6 3.0L Diesel Turbo	VO-129	VA-371 ¹¹²		
----------------------	--------	-----------------------	--	--

R350

V6 3.5L	VO-103	VA-132 ¹¹²		NS ⁴³⁷
---------	--------	-----------------------	--	-------------------

R550

V8 5.5	VO-103	VA-132		
--------	--------	--------	--	--

S450 (Canada)

V8 4.6L FI	VO-103	VA-132 ¹¹²		LF ⁴⁵⁰
------------	--------	-----------------------	--	-------------------

S550

V8 5.5L FI	VO-103	VA-132 ¹¹²		LF ⁴⁵⁰
------------	--------	-----------------------	--	-------------------

S63 AMG

V8 6.3L FI				LF ⁴⁵⁰
------------	--	--	--	-------------------

Se reporter à table de matière pour les notes en bas de page en français. Utilize el contenido para ver notas a pie.

NS - Non-Serviceable / Non réparable / No reparable LF - Life-Time Filter / Filtro para toda la vida / Filtre à vie

¹¹² Requires two (2). ⁴³⁷ Requires replacement of the complete fuel pump/fuel filter module. ⁴⁵⁰ Lifetime filter. Does not require replacement under normal conditions. ^{X135}Dust filter serviced under hood. ^{Z135}Dust and odor filter serviced under glove box.



MERCEDES-BENZ (cont'd)

	Oil	Air	Cabin*	Fuel
2008				
S65 AMG				
V12 6.0L Turbo				LF ⁴⁵⁰
SL55				
V8 5.5L FI (S.C.)	VO-103			
SL550				
V8 5.5L FI	VO-103	VA-132 ¹¹²		
SLK280				
V6 3.0L FI	VO-103	VA-132 ¹¹²		NS ⁴³⁷
SLK350				
V6 3.5L FI	VO-103	VA-132 ¹¹²		NS ⁴³⁷
SLK55 AMG				
V8 5.5L		VA-132 ¹¹²		NS ⁴³⁷
2007				
C230				
V6 2.5L FI	VO-103	VA-132	VCA-1106 ^{X135} VCA-1126 ^{Z135}	NS ⁴³⁷
C280				
V6 3.0L FI	VO-103	VA-132 ¹¹²	VCA-1106 ^{X135} VCA-1126 ^{Z135}	NS ⁴³⁷
C350				
V6 3.5L	VO-103	VA-132 ¹¹²	VCA-1106 ^{X135} VCA-1126 ^{Z135}	NS ⁴³⁷
CL550				
V8 5.5L FI	VO-103	VA-132 ¹¹²		
CLK350				
V6 3.5L FI	VO-103	VA-132 ¹¹²	VCA-1106 ^{X135} VCA-1126 ^{Z135}	NS ⁴³⁷
CLK550				
V8 5.5L FI	VO-103	VA-132 ¹¹²	VCA-1106 ^{X135} VCA-1126 ^{Z135}	
CLK63 AMG				
V8 6.2L FI			VCA-1106 ^{X135} VCA-1126 ^{Z135}	NS ⁴³⁷
CLS550				
V8 5.5L FI	VO-103	VA-132 ¹¹²		LF ⁴⁵⁰
E280				
V6 3.0L FI	VO-103	VA-132 ¹¹²		NS ⁴³⁷
E320 Bluetec				
V6 3.0L DI Turbo Diesel	VO-129	VA-371 ¹¹²		
E350				
V6 3.5L FI	VO-103	VA-132 ¹¹²		NS ⁴³⁷
E550				
V8 5.5L FI	VO-103	VA-132 ¹¹²		
E63 AMG				
V8 6.3L FI				LF ⁴⁵⁰
G500				
V8 5.0L FI	VO-103	VA-132 ¹¹²		
G55				
V8 5.5L FI (S.C.)	VO-103			
GL320 CDI				
V6 3.0L Diesel Turbo	VO-129	VA-371 ¹¹²		

Se reporter à table de matière pour les notes en bas de page en français. Utilize el contenido para ver notas a pie.

NS - Non-Serviceable / Non réparable / No reparable LF - Life-Time Filter / Filtro para toda la vida / Filtre à vie

¹¹² Requires two (2). ⁴³⁷ Requires replacement of the complete fuel pump/fuel filter module. ⁴⁵⁰ Lifetime filter. Does not require replacement under normal conditions. ^{X135}Dust filter serviced under hood. ^{Z135}Dust and odor filter serviced under glove box.



MERCEDES-BENZ (cont'd)

2007

GL450

V8 4.6L	VO-103	VA-132 ¹¹²		NS ⁴³⁷
---------	--------	-----------------------	--	-------------------

ML320 CDI

V6 3.0L Diesel Turbo	VO-129	VA-371 ¹¹²		
----------------------	--------	-----------------------	--	--

ML350

V6 3.5L	VO-103	VA-132 ¹¹²		NS ⁴³⁷
---------	--------	-----------------------	--	-------------------

ML500

V8 5.0L FI	VO-103	VA-132 ¹¹²		NS ⁴³⁷
------------	--------	-----------------------	--	-------------------

ML63 AMG

V8 6.2L				LF ⁴⁵⁰
---------	--	--	--	-------------------

R320 CDI

V6 3.0L Diesel Turbo	VO-129	VA-371 ¹¹²		
----------------------	--------	-----------------------	--	--

R350

V6 3.5L	VO-103	VA-132 ¹¹²		NS ⁴³⁷
---------	--------	-----------------------	--	-------------------

R500

V8 5.0L FI	VO-103	VA-132 ¹¹²		NS ⁴³⁷
------------	--------	-----------------------	--	-------------------

S550

V8 5.5L FI	VO-103	VA-132 ¹¹²		LF ⁴⁵⁰
------------	--------	-----------------------	--	-------------------

S65 AMG

V12 6.0L Turbo				LF ⁴⁵⁰
----------------	--	--	--	-------------------

SL55

V8 5.5L FI (S.C.)	VO-103			
-------------------	--------	--	--	--

SL550

V8 5.5L FI	VO-103	VA-132 ¹¹²		
------------	--------	-----------------------	--	--

SLK280

V6 3.0L FI	VO-103	VA-132 ¹¹²		NS ⁴³⁷
------------	--------	-----------------------	--	-------------------

SLK350

V6 3.5L FI	VO-103	VA-132 ¹¹²		NS ⁴³⁷
------------	--------	-----------------------	--	-------------------

SLK55 AMG

V8 5.5L		VA-132 ¹¹²		NS ⁴³⁷
---------	--	-----------------------	--	-------------------

2006

C230

V6 2.5L FI	VO-103	VA-132	VCA-1106 ^{X135} VCA-1126 ^{Z135}	NS ⁴³⁷
------------	--------	--------	--	-------------------

C280

V6 3.0L FI	VO-103	VA-132 ¹¹²	VCA-1106 ^{X135} VCA-1126 ^{Z135}	NS ⁴³⁷
------------	--------	-----------------------	--	-------------------

C350

V6 3.5L	VO-103	VA-132 ¹¹²	VCA-1106 ^{X135} VCA-1126 ^{Z135}	NS ⁴³⁷
---------	--------	-----------------------	--	-------------------

C55 AMG

V8 5.5L FI	VO-103	VA-132 ¹¹²	VCA-1106 ^{X135} VCA-1126 ^{Z135}	
------------	--------	-----------------------	--	--

CL500

V8 5.0L FI	VO-103	VA-132 ¹¹²		
------------	--------	-----------------------	--	--

CL55

V8 5.5L FI (S.C.)	VO-103			
-------------------	--------	--	--	--

CLK350

V6 3.5L FI	VO-103	VA-132 ¹¹²	VCA-1106 ^{X135} VCA-1126 ^{Z135}	NS ⁴³⁷
------------	--------	-----------------------	--	-------------------

Se reporter à table de matière pour les notes en bas de page en français. Utilize el contenido para ver notas a pie.

NS - Non-Serviceable / Non réparable / No reparable LF - Life-Time Filter / Filtro para toda la vida / Filtre à vie

¹¹² Requires two (2). ⁴³⁷ Requires replacement of the complete fuel pump/fuel filter module. ⁴⁵⁰ Lifetime filter. Does not require replacement under normal conditions. ^{X135}Dust filter serviced under hood. ^{Z135}Dust and odor filter serviced under glove box.



MERCEDES-BENZ (cont'd)

	Oil	Air	Cabin*	Fuel
2006				
CLK500				
V8 5.0L FI	VO-103	VA-132 ¹¹²	VCA-1106 ^{X135} VCA-1126 ^{Z135}	NS ⁴³⁷
CLK55				
V8 5.5L FI	VO-103		VCA-1106 ^{X135} VCA-1126 ^{Z135}	NS ⁴³⁷
CLS55				
V8 5.5L FI (S.C.)	VO-103			LF ⁴⁵⁰
CLS500				
V8 5.0L FI	VO-103	VA-132		LF ⁴⁵⁰
E320 CDI				
6 cyl 3.2L Diesel Turbo	VO-137			
E350				
V6 3.5L FI	VO-103	VA-132 ¹¹²		NS ⁴³⁷
E500				
V8 5.0L FI	VO-103	VA-132 ¹¹²		NS ⁴³⁷
E55				
V8 5.5L FI (S.C.)	VO-103			NS ⁴³⁷
G500				
V8 5.0L FI	VO-103	VA-132 ¹¹²		
G55				
V8 5.5L FI (S.C.)	VO-103			
ML350				
V6 3.5L	VO-103	VA-132 ¹¹²		NS ⁴³⁷
ML500				
V8 5.0L FI	VO-103	VA-132 ¹¹²		NS ⁴³⁷
R350				
V6 3.5L	VO-103	VA-132 ¹¹²		NS ⁴³⁷
R500				
V8 5.0L FI	VO-103	VA-132 ¹¹²		NS ⁴³⁷
S350				
V6 3.7L FI	VO-103	VA-132 ¹¹²		
S430				
V8 4.3L FI	VO-103	VA-132 ¹¹²		
S500				
V8 5.0L FI	VO-103	VA-132 ¹¹²		
S55 AMG				
V8 5.5L FI (S.C.)	VO-103			
SL500				
V8 5.0L FI	VO-103	VA-132 ¹¹²		
SL55				
V8 5.5L FI (S.C.)	VO-103			
SLK280				
V6 3.0L FI	VO-103	VA-132 ¹¹²		NS ⁴³⁷
SLK350				
V6 3.5L FI	VO-103	VA-132 ¹¹²		NS ⁴³⁷
SLK55 AMG				
V8 5.5L	VO-103	VA-132 ¹¹²		NS ⁴³⁷
2005				
C230				
4 cyl 1.8L FI (S.C.)			VCA-1106 ^{X135} VCA-1126 ^{Z135}	

Se reporter à table de matière pour les notes en bas de page en français. Utilize el contenido para ver notas a pie.

NS - Non-Serviceable / Non réparable / No reparable LF - Life-Time Filter / Filtro para toda la vida / Filtre à vie

¹¹² Requires two (2). ⁴³⁷ Requires replacement of the complete fuel pump/fuel filter module. ⁴⁵⁰ Lifetime filter. Does not require replacement under normal conditions. ^{X135}Dust filter serviced under hood. ^{Z135}Dust and odor filter serviced under glove box.



MERCEDES-BENZ (cont'd)

2005

C240

V6 2.6L FI	VO-103	VA-132 ¹¹²	VCA-1106 ^{X135} VCA-1126 ^{Z135}	
------------	--------	-----------------------	--	--

C320

V6 3.2L FI	VO-103	VA-132 ¹¹²	VCA-1106 ^{X135} VCA-1126 ^{Z135}	
------------	--------	-----------------------	--	--

C55 AMG

V8 5.5L FI	VO-103	VA-132 ¹¹²	VCA-1106 ^{X135} VCA-1126 ^{Z135}	
------------	--------	-----------------------	--	--

CL500

V8 5.0L FI	VO-103	VA-132 ¹¹²		
------------	--------	-----------------------	--	--

CL55

V8 5.5L FI (S.C.)	VO-103			
-------------------	--------	--	--	--

CLK320

V6 3.2L FI	VO-103	VA-132 ¹¹²	VCA-1106 ^{X135} VCA-1126 ^{Z135}	
------------	--------	-----------------------	--	--

CLK500

V8 5.0L FI	VO-103	VA-132 ¹¹²	VCA-1106 ^{X135} VCA-1126 ^{Z135}	
------------	--------	-----------------------	--	--

CLK55

V8 5.5L FI	VO-103		VCA-1106 ^{X135} VCA-1126 ^{Z135}	
------------	--------	--	--	--

E320

V6 3.2L FI	VO-69	VA-132 ¹¹²		NS ⁴³⁷
------------	-------	-----------------------	--	-------------------

E320 CDI

6 cyl 3.2L Diesel Turbo	VO-137			
-------------------------	--------	--	--	--

E500

V8 5.0L FI	VO-103	VA-132 ¹¹²		NS ⁴³⁷
------------	--------	-----------------------	--	-------------------

E55

V8 5.5L FI (S.C.)	VO-103			NS ⁴³⁷
-------------------	--------	--	--	-------------------

G500

V8 5.0L FI	VO-103	VA-132 ¹¹²		
------------	--------	-----------------------	--	--

G55

V8 5.5L FI (S.C.)	VO-103	VA-132 ¹¹²		
-------------------	--------	-----------------------	--	--

ML350

V6 3.7L FI	VO-103			
------------	--------	--	--	--

ML500

V8 5.0L FI	VO-103			
------------	--------	--	--	--

S430

V8 4.3L FI	VO-103	VA-132 ¹¹²		
------------	--------	-----------------------	--	--

S500

V8 5.0L FI	VO-103	VA-132 ¹¹²		
------------	--------	-----------------------	--	--

S55 AMG

V8 5.5L FI (S.C.)	VO-103			
-------------------	--------	--	--	--

SL500

V8 5.0L FI	VO-69	VA-132 ¹¹²		
------------	-------	-----------------------	--	--

SL55

V8 5.5L FI (S.C.)	VO-69			
-------------------	-------	--	--	--

SLK350

V6 3.5L FI	VO-103	VA-132 ¹¹²		NS ⁴³⁷
------------	--------	-----------------------	--	-------------------

SLK55 AMG

V8 5.5L	VO-103	VA-132 ¹¹²		NS ⁴³⁷
---------	--------	-----------------------	--	-------------------

Se reporter à table de matière pour les notes en bas de page en français. Utilize el contenido para ver notas a pie.

NS - Non-Serviceable / Non réparable / No reparable LF - Life-Time Filter / Filtro para toda la vida / Filtre à vie

¹¹² Requires two (2). ⁴³⁷ Requires replacement of the complete fuel pump/fuel filter module. ^{X135}Dust filter serviced under hood. ^{Z135}Dust and odor filter serviced under glove box.



MERCEDES-BENZ (cont'd)

	Oil	Air	Cabin*	Fuel
2004				
C230				
4 cyl. 1.8L FI (S.C.)			VCA-1106 ^{X135} VCA-1126 ^{Z135}	
C240				
V6 2.6L FI	VO-69	VA-132 ¹¹²	VCA-1106 ^{X135} VCA-1126 ^{Z135}	
C32				
V6 3.2L FI (S.C.)	VO-69		VCA-1106 ^{X135} VCA-1126 ^{Z135}	
C320				
V6 3.2L FI	VO-69	VA-132 ¹¹²	VCA-1106 ^{X135} VCA-1126 ^{Z135}	
CL500				
V8 5.0L FI	VO-69	VA-132 ¹¹²		
CL55				
V8 5.5L FI (S.C.)	VO-69			
CLK320				
V6 3.2L FI	VO-69	VA-132 ¹¹²	VCA-1106 ^{X135} VCA-1126 ^{Z135}	
CLK500				
V8 5.0L FI	VO-69	VA-132 ¹¹²	VCA-1106 ^{X135} VCA-1126 ^{Z135}	
CLK55				
V8 5.5L FI	VO-69	VA-132 ¹¹²	VCA-1106 ^{X135} VCA-1126 ^{Z135}	
E320				
V6 3.2L FI	VO-69	VA-132 ¹¹²		NS ⁴³⁷
E500				
V8 5.0L FI	VO-69	VA-132 ¹¹²		
E55				
V8 5.5L FI (S.C.)	VO-69			
G500				
V8 5.0L FI	VO-69	VA-132 ¹¹²		
G55				
V8 5.5L FI	VO-69	VA-132 ¹¹²		
ML350				
V6 3.7L FI	VO-69			
ML500				
V8 5.0L FI	VO-69			
S430				
V8 4.3L FI	VO-69	VA-132 ¹¹²		
S500				
V8 5.0L FI	VO-69	VA-132 ¹¹²		
S55 AMG				
V8 5.5L FI (S.C.)	VO-69			
SL500				
V8 5.0L FI	VO-69	VA-132 ¹¹²		
SL55				
V8 5.5L FI (S.C.)	VO-69			
SLK230				
4 cyl. 2.3L FI (S.C.)	VO-62			

Se reporter à table de matière pour les notes en bas de page en français. Utilize el contenido para ver notas a pie.

NS - Non-Serviceable / Non réparable / No repairable LF - Life-Time Filter / Filtro para toda la vida / Filtre à vie

¹¹² Requires two (2). ⁴³⁷ Requires replacement of the complete fuel pump/fuel filter module. ^{X135}Dust filter serviced under hood. ^{Z135}Dust and odor filter serviced under glove box.



MERCEDES-BENZ (cont'd)

2004

SLK32

V6 3.2L FI (S.C.)	VO-69			
-------------------	-------	--	--	--

SLK320

V6 3.2L FI	VO-69	VA-400 ¹¹²		
------------	-------	-----------------------	--	--

2003

C230

4 cyl. 1.8L FI (S.C.)			VCA-1106 ^{X135} VCA-1126 ^{Z135}	
-----------------------	--	--	--	--

C240

V6 2.6L FI	VO-69	VA-132 ¹¹²	VCA-1106 ^{X135} VCA-1126 ^{Z135}	
------------	-------	-----------------------	--	--

C32

V6 3.2L FI (S.C.)	VO-69		VCA-1106 ^{X135} VCA-1126 ^{Z135}	
-------------------	-------	--	--	--

C320

V6 3.2L FI	VO-69	VA-132 ¹¹²	VCA-1106 ^{X135} VCA-1126 ^{Z135}	
------------	-------	-----------------------	--	--

CL500

V8 5.0L FI	VO-69	VA-132 ¹¹²		
------------	-------	-----------------------	--	--

CL55

V8 5.5L FI (S.C.)	VO-69	VA-132 ¹¹²		
-------------------	-------	-----------------------	--	--

CLK320

V6 3.2L FI	VO-69	VA-132	VCA-1106 ^{X135} VCA-1126 ^{Z135}	
------------	-------	--------	--	--

CLK320 Cabriolet

V6 3.2L FI	VO-69	VA-132		
------------	-------	--------	--	--

CLK430

V8 4.3L FI	VO-69			
------------	-------	--	--	--

CLK500

V8 5.0L FI	VO-69	VA-132	VCA-1106 ^{X135} VCA-1126 ^{Z135}	
------------	-------	--------	--	--

CLK55

V8 5.5L FI	VO-69	VA-132	VCA-1106 ^{X135} VCA-1126 ^{Z135}	
------------	-------	--------	--	--

E320

V6 3.2L FI	VO-69	VA-132 ¹¹²		NS ⁴³⁷
------------	-------	-----------------------	--	-------------------

E500

V8 5.0L FI	VO-69	VA-132 ¹¹²		
------------	-------	-----------------------	--	--

E55

V8 5.5L FI (S.C.)	VO-69			
-------------------	-------	--	--	--

G500

V8 5.0L FI	VO-69	VA-132 ¹¹²		
------------	-------	-----------------------	--	--

G55

V8 5.5L FI	VO-69	VA-132 ¹¹²		
------------	-------	-----------------------	--	--

ML320

V6 3.2L FI	VO-69			
------------	-------	--	--	--

ML350

V6 3.7L FI	VO-69			
------------	-------	--	--	--

ML500

V8 5.0L FI	VO-69			
------------	-------	--	--	--

ML55

V8 5.5L	VO-69			
---------	-------	--	--	--

Se reporter à table de matière pour les notes en bas de page en français. Utilize el contenido para ver notas a pie.

NS - Non-Serviceable / Non réparable / No reparable LF - Life-Time Filter / Filtro para toda la vida / Filtre à vie

¹¹² Requires two (2). ⁴³⁷ Requires replacement of the complete fuel pump/fuel filter module. ^{X135}Dust filter serviced under hood. ^{Z135}Dust and odor filter serviced under glove box.



MERCEDES-BENZ (cont'd)

2003				
S430				
V8 4.3L FI	VO-69	VA-132 ¹¹²		
S500				
V8 5.0L FI	VO-69	VA-132 ¹¹²		
S55 AMG				
V8 5.5L FI (S.C.)	VO-69	VA-132 ¹¹²		
SL500				
V8 5.0L FI	VO-69	VA-132 ¹¹²		
SL55				
V8 5.5L FI (S.C.)	VO-69			
SLK230				
4 cyl. 2.3L FI (S.C.)	VO-62			
SLK32				
V6 3.2L FI (S.C.)	VO-69			
SLK320				
V6 3.2L FI	VO-69	VA-400 ¹¹²		
2002				
C230				
4 cyl. 2.3L FI (S.C.)	VO-62		VCA-1106 ^{X135} VCA-1126 ^{Z135}	
C240				
V6 2.6L FI	VO-69	VA-132 ¹¹²	VCA-1106 ^{X135} VCA-1126 ^{Z135}	
C32				
V6 3.2L FI (S.C.)	VO-69		VCA-1106 ^{X135} VCA-1126 ^{Z135}	
C320				
V6 3.2L FI	VO-69	VA-132 ¹¹²	VCA-1106 ^{X135} VCA-1126 ^{Z135}	
CL500				
V8 5.0L FI	VO-69	VA-132 ¹¹²		
CL55				
V8 5.5L FI	VO-69	VA-132		
CL600				
V12 5.8L FI	VO-69			
CLK320				
V6 3.2L FI	VO-69			
CLK430				
V8 4.3L FI	VO-69			
CLK55				
V8 5.5L FI	VO-69			
E320				
V6 3.2L FI	VO-69			
E430				
V8 4.3L FI	VO-69			
E55				
V8 5.5L FI	VO-69			
G500				
V8 5.0L FI	VO-69	VA-132		
ML320				
V6 3.2L FI	VO-69			

Se reporter à table de matière pour les notes en bas de page en français. Utilize el contenido para ver notas a pie.

NS - Non-Serviceable / Non réparable / No reparable LF - Life-Time Filter / Filtro para toda la vida / Filtre à vie

¹¹² Requires two (2). ^{X135} Dust filter serviced under hood. ^{Z135} Dust and odor filter serviced under glove box.



MERCEDES-BENZ (cont'd)

2002

ML500

V8 5.0L FI	VO-69			
------------	-------	--	--	--

ML55

V8 5.5L	VO-69			
---------	-------	--	--	--

S430

V8 4.3L FI	VO-69	VA-132		
------------	-------	--------	--	--

S500

V8 5.0L FI	VO-69	VA-132		
------------	-------	--------	--	--

S55 AMG

V8 5.5L FI	VO-69	VA-132		
------------	-------	--------	--	--

S600

V12 5.8L FI	VO-69			
-------------	-------	--	--	--

SL500

V8 5.0L FI	VO-69	VA-132 ¹¹²		
------------	-------	-----------------------	--	--

SLK230

4 cyl. 2.3L FI (S.C.)	VO-62			
-----------------------	-------	--	--	--

SLK32

V6 3.2L FI (S.C.)	VO-69			
-------------------	-------	--	--	--

SLK320

V6 3.2L FI	VO-69	VA-400 ¹¹²		
------------	-------	-----------------------	--	--

2001

C240

V6 2.6L FI	VO-69	VA-132 ¹¹²	VCA-1106 ^{X135} VCA-1126 ^{Z135}	
------------	-------	-----------------------	--	--

C320

V6 3.2L FI	VO-69	VA-132 ¹¹²	VCA-1106 ^{X135} VCA-1126 ^{Z135}	
------------	-------	-----------------------	--	--

CL500

V8 5.0L FI	VO-69	VA-132 ¹¹²		
------------	-------	-----------------------	--	--

CL55

V8 5.5L FI	VO-69	VA-132		
------------	-------	--------	--	--

CL600

V12 5.8L FI	VO-69			
-------------	-------	--	--	--

CLK320

V6 3.2L FI	VO-69			
------------	-------	--	--	--

CLK430

V8 4.3L FI	VO-69			
------------	-------	--	--	--

CLK55

V8 5.5L FI	VO-69			
------------	-------	--	--	--

E320

V6 3.2L FI	VO-69			
------------	-------	--	--	--

E430

V8 4.3L FI	VO-69			
------------	-------	--	--	--

E55

V8 5.5L FI	VO-69			
------------	-------	--	--	--

ML320

V6 3.2L FI	VO-69			
------------	-------	--	--	--

ML430

V8 4.3L FI	VO-69			
------------	-------	--	--	--

ML55

V8 5.5L	VO-69			
---------	-------	--	--	--

Se reporter à table de matière pour les notes en bas de page en français. Utilize el contenido para ver notas a pie.

NS - Non-Serviceable / Non réparable / No reparable LF - Life-Time Filter / Filtro para toda la vida / Filtre à vie

¹¹² Requires two (2). ^{X135}Dust filter serviced under hood. ^{Z135}Dust and odor filter serviced under glove box.



MERCEDES-BENZ (cont'd)

	Oil	Air	Cabin*	Fuel
2001				
S430				
V8 4.3L FI	VO-69	VA-132		
S500				
V8 5.0L FI	VO-69	VA-132		
S55 AMG				
V8 5.5L FI	VO-69	VA-132		
S600				
V12 5.8L FI	VO-69			
SL500				
V8 5.0L FI	VO-69	VA-132 ¹¹²		
SLK230				
4 cyl. 2.3L FI (S.C.)	VO-62			
SLK320				
V6 3.2L FI	VO-69	VA-400 ¹¹²		
2000				
C230				
4 cyl. 2.3L FI (S.C.)	VO-62			
C280				
V6 2.8L FI	VO-69			
C43 AMG				
V8 4.3L FI	VO-69			
CL500				
V8 5.0L FI	VO-69	VA-132		
CLK320				
V6 3.2L FI	VO-69			
CLK430				
V8 4.3L FI	VO-69			
E320				
V6 3.2L FI	VO-69			
E430				
V8 4.3L FI	VO-69			
E55				
V8 5.5L FI	VO-69			
ML320				
V6 3.2L FI	VO-69			
ML430				
V8 4.3L FI	VO-69			
ML55				
V8 5.5L	VO-69			
S430				
V8 4.3L FI	VO-69	VA-132 ¹¹²		
S500				
V8 5.0L FI	VO-69	VA-132 ¹¹²		
SL500				
V8 5.0L FI	VO-69			
SLK230				
4 cyl. 2.3L FI (S.C.)	VO-62			
1999				
C230				
4 cyl. 2.3L FI (S.C.)	VO-62			

Se reporter à table de matière pour les notes en bas de page en français. Utilize el contenido para ver notas a pie.

NS - Non-Serviceable / Non réparable / No reparable LF - Life-Time Filter / Filtro para toda la vida / Filtre à vie

¹¹² Requires two (2).



MERCEDES-BENZ (cont'd)

1999

C280

V6 2.8L FI	VO-69			
------------	-------	--	--	--

C43 AMG

V8 4.3L FI	VO-69			
------------	-------	--	--	--

CL500

V8 5.0L FI	VO-70	VA-132		
------------	-------	--------	--	--

CLK320

V6 3.2L FI	VO-69			
------------	-------	--	--	--

CLK430

V8 4.3L FI	VO-69			
------------	-------	--	--	--

E320

V6 3.2L FI	VO-69			
------------	-------	--	--	--

E430

V8 4.3L FI	VO-69			
------------	-------	--	--	--

E55

V8 5.5L FI	VO-69			
------------	-------	--	--	--

ML320

V6 3.2L FI	VO-69			
------------	-------	--	--	--

ML430

V8 4.3L FI	VO-69			
------------	-------	--	--	--

S320

6 cyl. 3.2L FI	VO-62			
----------------	-------	--	--	--

S420

V8 4.2L FI	VO-70			
------------	-------	--	--	--

S500

V8 5.0L FI	VO-70			
------------	-------	--	--	--

SL500

V8 5.0L FI	VO-69			
------------	-------	--	--	--

SLK230

4 cyl. 2.3L FI (S.C.)	VO-62			
-----------------------	-------	--	--	--

1998

C230

4 cyl. 2.3L FI	VO-62			
----------------	-------	--	--	--

C280

V6 2.8L FI	VO-69			
------------	-------	--	--	--

C43 AMG

V8 4.3L FI	VO-69			
------------	-------	--	--	--

CL500

V8 5.0L FI	VO-70	VA-132		
------------	-------	--------	--	--

CLK320

V6 3.2L FI	VO-69			
------------	-------	--	--	--

E320

V6 3.2L FI	VO-69			
------------	-------	--	--	--

E430

V8 4.3L FI	VO-69			
------------	-------	--	--	--

ML320

V6 3.2L FI	VO-69			
------------	-------	--	--	--

S320

6 cyl. 3.2L FI	VO-62			
----------------	-------	--	--	--

S420

V8 4.2L FI	VO-70			
------------	-------	--	--	--

Se reporter à table de matière pour les notes en bas de page en français. Utilize el contenido para ver notas a pie.

NS - Non-Serviceable / Non réparable / No reparable LF - Life-Time Filter / Filtro para toda la vida / Filtre à vie



MERCEDES-BENZ (cont'd)

	Oil	Air	Cabin*	Fuel
1998				
S500				
V8 5.0L FI	VO-70			
SL500				
V8 5.0L FI	VO-70			
SLK230				
4 cyl. 2.3L FI (S.C.)	VO-62			
1997				
C230				
4 cyl. 2.3L FI	VO-62			
C280				
6 cyl. 2.8L FI	VO-62			
C36				
6 cyl. 3.6L FI	VO-62			
E320				
6 cyl. 3.2L FI	VO-62			
E420				
V8 4.2L FI	VO-70			
S320				
6 cyl. 3.2L FI	VO-62			
S420				
V8 4.2L FI	VO-70			
S500				
V8 5.0L FI	VO-70			
SL320				
6 cyl. 3.2L FI	VO-62			
SL500				
V8 5.0L FI	VO-70			
1996				
C220				
4 cyl. 2.2L FI	VO-62			
C280				
6 cyl. 2.8L FI	VO-62			
C36				
6 cyl. 3.6L FI	VO-62			
E320				
6 cyl. 3.2L FI	VO-62			
S320				
6 cyl. 3.2L FI	VO-62			
S420				
V8 4.2L FI	VO-70			
S500				
V8 5.0L FI	VO-70			
SL320				
6 cyl. 3.2L FI	VO-62			
SL500				
V8 5.0L FI	VO-70			
1995				
C220				
4 cyl. 2.2L FI	VO-62			
C280				
6 cyl. 2.8L FI	VO-62			

Se reporter à table de matière pour les notes en bas de page en français. Utilize el contenido para ver notas a pie.
 NS - Non-Serviceable / Non réparable / No reparable LF - Life-Time Filter / Filtro para toda la vida / Filtre à vie



MERCEDES-BENZ (cont'd)

1995

C36

6 cyl. 3.6L FI	VO-62			
----------------	-------	--	--	--

E300D

6 cyl. 3.0L Diesel			VCA-1058	
--------------------	--	--	----------	--

E320

6 cyl. 3.2L FI	VO-62		VCA-1058	
----------------	-------	--	----------	--

E420

V8 4.2L FI	VO-70		VCA-1058	
------------	-------	--	----------	--

S320

6 cyl. 3.2L FI	VO-62			
----------------	-------	--	--	--

S420

V8 4.2L FI	VO-70			
------------	-------	--	--	--

S500

V8 5.0L FI	VO-70			
------------	-------	--	--	--

SL320

6 cyl. 3.2L FI	VO-62			
----------------	-------	--	--	--

SL500

V8 5.0L FI	VO-70			
------------	-------	--	--	--

MERCURY

2011

Grand Marquis

V8 4.6L (V) FI (Flex Fuel)	VO-88	VA-205		
----------------------------	-------	--------	--	--

Mariner

4 cyl 2.5L	VO-25	VA-149	VCA-1104	VG-32
------------	-------	--------	----------	-------

4 cyl. 2.5L (Hybrid)	VO-25	VA-249	VCA-1104 ^{X909}	VG-32
----------------------	-------	--------	--------------------------	-------

			VCA-1101 ^{Z909}	
--	--	--	--------------------------	--

V6 3.0L FI (Flex Fuel)	VO-88	VA-246	VCA-1104	VG-32
------------------------	-------	--------	----------	-------

Milan

4 cyl. 2.5L (A) FI	VO-25	VA-215	VCA-1059	NS ⁴³⁷
--------------------	-------	--------	----------	-------------------

V6 3.0L (G) FI (Flex Fuel)	VO-88	VA-216	VCA-1059	NS ⁴³⁷
----------------------------	-------	--------	----------	-------------------

Milan Hybrid

4 cyl. 2.5L (3) FI (Hybrid)	VO-25		VCA-1059	NS ⁴³⁷
-----------------------------	-------	--	----------	-------------------

2010

Grand Marquis

V8 4.6L (V) FI (Flex Fuel)	VO-88	VA-205		
----------------------------	-------	--------	--	--

Mariner

4 cyl 2.5L	VO-80 ^{X374}			
------------	-----------------------	--	--	--

	VO-25 ^{Z374}	VA-149	VCA-1104	VG-32
--	-----------------------	--------	----------	-------

4 cyl. 2.5L (Hybrid)	VO-80 ^{X374}	VA-249	VCA-1104 ^{X909}	VG-32
----------------------	-----------------------	--------	--------------------------	-------

	VO-25 ^{Z374}		VCA-1101 ^{Z909}	
--	-----------------------	--	--------------------------	--

V6 3.0L	VO-88	VA-246	VCA-1104	VG-32
---------	-------	--------	----------	-------

Milan

4 cyl. 2.5L (A) FI	VO-25	VA-215	VCA-1059	NS ⁴³⁷
--------------------	-------	--------	----------	-------------------

V6 3.0L (G) FI (Flex Fuel)	VO-88	VA-216	VCA-1059	NS ⁴³⁷
----------------------------	-------	--------	----------	-------------------

Milan Hybrid

4 cyl. 2.5L (3) FI (Hybrid)	VO-25		VCA-1059	NS ⁴³⁷
-----------------------------	-------	--	----------	-------------------

Mountaineer

V6 4.0L (E) FI	VO-88	VA-162		
----------------	-------	--------	--	--

V8 4.6L (8) FI	VO-88	VA-222		
----------------	-------	--------	--	--

--	--	--	--	--

Se reporter à table de matière pour les notes en bas de page en français. Utilize el contenido para ver notas a pie.

NS - Non-Serviceable / Non réparable / No reparable LF - Life-Time Filter / Filtro para toda la vida / Filtre à vie

⁴³⁷ Requires replacement of the complete fuel pump/fuel filter module. ^{X374}Cartridge ^{X909}Dust filter ^{Z374}Spin-on ^{Z909}High Voltage battery pack on driver side rear cargo trim panel.



MERCURY (cont'd)

	Oil	Air	Cabin*	Fuel
2009				
Grand Marquis				
V8 4.6L (W) FI	VO-88	VA-205		
V8 4.6L (V) FI (Flex Fuel)	VO-88	VA-205		
Mariner				
4 cyl. 2.5L	VO-80 ^{X374} VO-25 ^{Z374}	VA-149	VCA-1104	VG-32
4 cyl. 2.5L (Hybrid)	VO-80 ^{X374} VO-25 ^{Z374}	VA-249	VCA-1104 ^{X909} VCA-1101 ^{Z909}	VG-32
V6 3.0L	VO-88	VA-246	VCA-1104	VG-32
Milan				
4 cyl. 2.3L (Z) FI	VO-80	VA-215		NS ⁴³⁷
V6 3.0L (1) FI	VO-88	VA-216		NS ⁴³⁷
Mountaineer				
V6 4.0L (E) FI	VO-88	VA-162		
V8 4.6L (8) FI	VO-88	VA-222		
Sable				
V6 3.5L (W) FI	VO-118 ^{X486} VO-88 ^{Z486}	VA-224		NS ⁴³⁷
2008				
Grand Marquis				
V8 4.6L (W) FI	VO-88	VA-205		
V8 4.6L (V) FI (Flex Fuel)	VO-88	VA-205		
Mariner				
4 cyl. 2.3L (Z)	VO-80 ^{X374} VO-25 ^{Z374}	VA-149	VCA-1104	VG-32
4 cyl. 2.3L (Hybrid)	VO-80	VA-249	VCA-1104 ^{X909} VCA-1101 ^{Z909}	VG-32
V6 3.0L	VO-88	VA-149	VCA-1104	VG-32
Milan				
4 cyl. 2.3L (Z) FI	VO-80 ^{X374} VO-25 ^{Z374}	VA-215		NS ⁴³⁷
V6 3.0L (1) FI	VO-88	VA-216		NS ⁴³⁷
Mountaineer				
V6 4.0L (E) FI	VO-88	VA-162		
V8 4.6L (8) FI	VO-88	VA-222		
Sable				
V6 3.5L (W) FI	VO-118	VA-224		NS ⁴³⁷
2007				
Grand Marquis				
V8 4.6L (W) FI	VO-88	VA-205		
V8 4.6L (V) FI (Flex Fuel)	VO-88	VA-205		
Mariner				
4 cyl. 2.3L (Z)	VO-80 ^{X374} VO-25 ^{Z374}	VA-149	VCA-1020	VG-16
4 cyl. 2.3L (Hybrid)	VO-80	VA-249	VCA-1020 ^{X505} VCA-1101 ^{Z505}	VG-16
V6 3.0L	VO-88	VA-149	VCA-1020	VG-16
Milan				
4 cyl. 2.3L (Z) FI	VO-80 ^{X374} VO-25 ^{Z374}	VA-215		NS ⁴³⁷
V6 3.0L (1) FI	VO-88	VA-216		NS ⁴³⁷

Se reporter à table de matière pour les notes en bas de page en français. Utilize el contenido para ver notas a pie.

NS - Non-Serviceable / Non réparable / No repairable LF - Life-Time Filter / Filtro para toda la vida / Filtre à vie

⁴³⁷ Requires replacement of the complete fuel pump/fuel filter module. ^{X374} Cartridge ^{X486} Before Production 1/16/09. ^{X505} Dust filter. ^{X909} Dust filter

^{Z374} Spin-on ^{Z486} After Production 1/15/09. ^{Z505} For High Voltage battery pack on driver side rear cargo trim panel. ^{Z909} High Voltage battery pack on driver side rear cargo trim panel.



MERCURY (cont'd)

2007

Montego

V6 3.0L FI	VO-88	VA-197		
------------	-------	--------	--	--

Monterey

V6 4.2L (2) FI	VO-118	VA-142	VCA-1008	
----------------	--------	--------	----------	--

Mountaineer

V6 4.0L (E) FI	VO-88	VA-162		
----------------	-------	--------	--	--

V8 4.6L (8) FI	VO-88	VA-222		
----------------	-------	--------	--	--

2006

Grand Marquis

V8 4.6L (W) FI	VO-88	VA-205		
----------------	-------	--------	--	--

V8 4.6L (V) FI (Flex Fuel)	VO-88	VA-205		
----------------------------	-------	--------	--	--

Mariner

4 cyl. 2.3L (Z)	VO-80 ^{X374}			
-----------------	-----------------------	--	--	--

	VO-25 ^{Z374}	VA-149	VCA-1020	VG-16
--	-----------------------	--------	----------	-------

4 cyl. 2.3L (Hybrid)	VO-80	VA-249	VCA-1020 ^{X505}	VG-16
----------------------	-------	--------	--------------------------	-------

			VCA-1101 ^{Z505}	
--	--	--	--------------------------	--

V6 3.0L	VO-88	VA-149	VCA-1020	VG-16
---------	-------	--------	----------	-------

Milan

4 cyl 2.3L (Z) FI	VO-80 ^{X374}			
-------------------	-----------------------	--	--	--

	VO-25 ^{Z374}	VA-215		NS ⁴³⁷
--	-----------------------	--------	--	-------------------

V6 3.0L (1) FI	VO-88	VA-216		NS ⁴³⁷
----------------	-------	--------	--	-------------------

Montego

V6 3.0L FI	VO-88	VA-197		
------------	-------	--------	--	--

Monterey

V6 4.2L (2) FI	VO-118	VA-142	VCA-1008	
----------------	--------	--------	----------	--

Mountaineer

V6 4.0L (E) FI	VO-88	VA-162		
----------------	-------	--------	--	--

V8 4.6L (8) FI	VO-88	VA-222		
----------------	-------	--------	--	--

2005

Grand Marquis

V8 4.6L (W) FI	VO-88	VA-205		
----------------	-------	--------	--	--

Mariner

4 cyl. 2.3L (Z)	VO-25	VA-149	VCA-1020	VG-16
-----------------	-------	--------	----------	-------

V6 3.0L	VO-88	VA-149	VCA-1020	VG-16
---------	-------	--------	----------	-------

Montego

V6 3.0L FI	VO-88	VA-197		
------------	-------	--------	--	--

Monterey

V6 4.2L (2) FI	VO-118	VA-142	VCA-1008	
----------------	--------	--------	----------	--

Mountaineer

V6 4.0L (E) FI	VO-88	VA-162		
----------------	-------	--------	--	--

V6 4.0L (K) FI (Flex Fuel)	VO-88	VA-162		
----------------------------	-------	--------	--	--

V8 4.6L (W) FI	VO-88	VA-162		
----------------	-------	--------	--	--

Sable

V6 3.0L (U) FI (12 Valve)	VO-118	VA-149	VCA-1001	
---------------------------	--------	--------	----------	--

V6 3.0L (S) FI (24 Valve)	VO-88	VA-149	VCA-1001	
---------------------------	-------	--------	----------	--

V6 3.0L (2) FI (Flex Fuel)	VO-118	VA-149	VCA-1001	
----------------------------	--------	--------	----------	--

2004

Grand Marquis

V8 4.6L (W) FI	VO-88	VA-205		
----------------	-------	--------	--	--

Marauder

V8 4.6L (V) FI	VO-88	VA-205		
----------------	-------	--------	--	--

Se reporter à table de matière pour les notes en bas de page en français. Utilize el contenido para ver notas a pie.

NS - Non-Serviceable / Non réparable / No reparable LF - Life-Time Filter / Filtro para toda la vida / Filtre à vie

⁴³⁷ Requires replacement of the complete fuel pump/fuel filter module. ^{X374} Cartridge ^{X505} Dust filter. ^{Z374} Spin-on ^{Z505} For High Voltage battery pack on driver side rear cargo trim panel.



MERCURY (cont'd)

	Oil	Air	Cabin*	Fuel
2004				
Monterey				
V6 4.2L (2) FI	VO-118	VA-142	VCA-1008	
Mountaineer				
V6 4.0L (E) FI	VO-88	VA-162		
V6 4.0L (K) FI (Flex Fuel)	VO-88	VA-162		
V8 4.6L (W) FI	VO-88	VA-162		
Sable				
V6 3.0L (U) FI (12 Valve)	VO-118	VA-149	VCA-1001	
V6 3.0L (S) FI (24 Valve)	VO-88	VA-149	VCA-1001	
V6 3.0L (2) FI (Flex Fuel)	VO-118	VA-149	VCA-1001	
2003				
Grand Marquis				
V8 4.6L (W) FI	VO-88	VA-205		
Marauder				
V8 4.6L FI	VO-88	VA-205		
Mountaineer				
V6 4.0L (K) FI (Flex Fuel)	VO-88	VA-162		
V8 4.6L (W) FI	VO-88	VA-162		
Sable				
V6 3.0L (2) (Flex Fuel)	VO-118	VA-149	VCA-1001	
V6 3.0L (U) FI (12 Valve)	VO-118	VA-149	VCA-1001	
V6 3.0L (S) FI (24 Valve)	VO-88	VA-149	VCA-1001	
2002				
Cougar				
4 cyl. 2.0L (3) FI	VO-118	VFAP-1612	VCA-1157	VG-16
V6 2.5L (L) FI	VO-88	VFAP-1613	VCA-1157	VG-16
Grand Marquis				
V8 4.6L (W) FI	VO-88	VA-205		
Mountaineer				
V6 4.0L (E) FI	VO-88	VA-162		
V6 4.0L (K) FI (Flex Fuel)	VO-88	VA-162		
V8 4.6L (W) FI	VO-88	VA-162		
Sable				
V6 3.0L (U) FI (12 Valve)	VO-118	VA-149	VCA-1001	
V6 3.0L (S) FI (24 Valve)	VO-88	VA-149	VCA-1001	
Villager				
V6 3.3L FI	VO-106	VFAP-7857		
2001				
Cougar				
4 cyl. 2.0L (3) FI	VO-118	VFAP-1612	VCA-1157	VG-16
V6 2.5L (G,L) FI	VO-88	VFAP-1613	VCA-1157	VG-16
Grand Marquis				
V8 4.6L (W) FI	VO-88	VA-205		
Mountaineer				
V6 4.0L (E) FI	VO-1 ¹⁵⁰² , X ³²³			
	VO-88 ^{Z323}	VA-260		
V8 5.0L (P) FI	VO-88	VA-260		
Sable				
V6 3.0L (2) (Flex Fuel)	VO-118	VA-149	VCA-1001	
V6 3.0L (U) FI (12 Valve)	VO-118	VA-149	VCA-1001	
V6 3.0L (S) FI (24 Valve)	VO-88	VA-149	VCA-1001	

Se reporter à table de matière pour les notes en bas de page en français. Utilize el contenido para ver notas a pie.

NS - Non-Serviceable / Non réparable / No repairable LF - Life-Time Filter / Filtro para toda la vida / Filtre à vie

¹⁵⁰²Alternate. Primary VO-118 ^{X323}with 3/4 inch threaded stud. ^{Z323}with 22mm threaded stud.



MERCURY (cont'd)

2001

Villager

V6 3.3L FI	VO-106	VFAP-7857		
------------	--------	-----------	--	--

2000

Cougar

4 cyl. 2.0L (3) FI	VO-118	VFAP-1612	VCA-1157	VG-16
V6 2.5L (L) FI	VO-88	VFAP-1613	VCA-1157	VG-16

Grand Marquis

V8 4.6L (W) FI	VO-88	VA-205		
----------------	-------	--------	--	--

Mountaineer

V6 4.0L (E) FI	VO-1 ^{X502} VO-118 ^{Z502} VO-88	VA-260 VA-260		
V8 5.0L (P) FI				

Mystique

4 cyl. 2.0L (3) FI	VO-118	VFAP-1612	VCA-1157	VG-16
V6 2.5L FI	VO-88	VFAP-1613	VCA-1157	VG-16

Sable

V6 3.0L (U) FI (12 Valve)	VO-118	VA-149	VCA-1001	VG-16
V6 3.0L (S) FI (24 Valve)	VO-88	VA-149	VCA-1001	VG-16

Villager

V6 3.3L FI	VO-106	VFAP-7857		
------------	--------	-----------	--	--

1999

Cougar

4 cyl. 2.0L (3) FI	VO-118	VFAP-1612	VCA-1157	VG-16
V6 2.5L (L) FI	VO-88	VFAP-1613	VCA-1157	VG-16

Grand Marquis

V8 4.6L (W) FI	VO-88	VA-205		
----------------	-------	--------	--	--

Mountaineer

V6 4.0L (E) FI	VO-1 ^{X502} VO-118 ^{Z502} VO-88	VA-260 VA-260		
V8 5.0L (P) FI				

Mystique

4 cyl. 2.0L (3) FI	VO-118	VFAP-1612	VCA-1157	VG-16
V6 2.5L (L) FI	VO-88	VFAP-1613	VCA-1157	VG-16

Sable

V6 3.0L (U) FI (12 Valve)	VO-118	VA-404	VCA-1001	VG-16
V6 3.0L (S) FI (24 Valve)	VO-88	VA-404	VCA-1001	VG-16

Tracer

4 cyl. 2.0L (P) FI	VO-118	VFAP-1643		
--------------------	--------	-----------	--	--

Villager

V6 3.3L FI	VO-106	VFAP-7857		
------------	--------	-----------	--	--

1998

Grand Marquis

V8 4.6L (W) FI	VO-88	VA-205		
----------------	-------	--------	--	--

Mountaineer

V6 4.0L (E) FI	VO-1 ^{X502} VO-118 ^{Z502} VO-88	VA-260 VA-260		VG-32 VG-32
V8 5.0L (P) FI				

Mystique

4 cyl. 2.0L (3) FI	VO-118	VFAP-1612	VCA-1157	VG-16
V6 2.5L (L) FI	VO-88	VFAP-1613	VCA-1157	VG-16

Sable

V6 3.0L (U) FI (12 Valve)	VO-118	VA-404	VCA-1001	VG-16
---------------------------	--------	--------	----------	-------

Se reporter à table de matière pour les notes en bas de page en français. Utilize el contenido para ver notas a pie.

NS - Non-Serviceable / Non réparable / No repairable LF - Life-Time Filter / Filtro para toda la vida / Filtre à vie

^{X502}Alternate ^{Z502}Primary



MERCURY (cont'd)

	Oil	Air	Cabin*	Fuel
1998				
Sable				
V6 3.0L (S) FI (24 Valve)	VO-88	VA-404	VCA-1001	VG-16
Tracer				
4 cyl. 2.0L (P) FI	VO-118	VFAP-1643		
Villager				
V6 3.0L FI	VO-25	VFAP-7857		
1997				
Cougar				
V6 3.8L (4) FI	VO-118	VA-88		
V8 4.6L (W) FI	VO-88	VA-88		
Grand Marquis				
V8 4.6L (W) FI	VO-88	VA-205		VG-16
Mountaineer				
V8 5.0L (P) FI	VO-88	VA-114 ^{X388} VFA-1641 ^{Z388} VA-260 ^{Y388}		VG-32
Mystique				
4 cyl. 2.0L (3) FI	VO-95	VFAP-1612	VCA-1157	VG-16
V6 2.5L (L) FI	VO-88	VFAP-1613	VCA-1157	VG-16
Sable				
V6 3.0L (U) FI (12 Valve)	VO-118	VA-404	VCA-1001	VG-16
V6 3.0L (S) FI (24 Valve)	VO-88	VA-404	VCA-1001	VG-16
Tracer				
4 cyl. 2.0L (P) FI	VO-118	VFAP-1643		
Villager				
V6 3.0L FI	VO-25	VFAP-7857		
1996				
Cougar				
V6 3.8L (4) FI	VO-118	VA-88		
V8 4.6L (W) FI	VO-88	VA-88		
Grand Marquis				
V8 4.6L (W,6) FI	VO-88	VA-205		VG-16
Mystique				
4 cyl. 2.0L (3) FI	VO-95	VFAP-1612	VCA-1157	VG-16
V6 2.5L (L) FI	VO-88	VFAP-1613	VCA-1157	VG-16
Sable				
V6 3.0L (U) FI (12 Valve)	VO-118	VA-404	VCA-1001	VG-16
V6 3.0L (S) FI (24 Valve)	VO-88	VA-404	VCA-1001	VG-16
Tracer				
4 cyl. 1.8L (8) FI	VO-106	VA-416		VG-16
4 cyl. 1.9L (J) FI	VO-118	VA-69		VG-16
Villager				
V6 3.0L FI	VO-25	VFAP-7857		
1995				
Cougar				
V6 3.8L (4) FI	VO-118	VA-88		
V8 4.6L (W) FI	VO-88	VA-88		
Grand Marquis				
V8 4.6L (W) FI	VO-88	VA-205		VG-16
Mystique				
4 cyl. 2.0L (3) FI	VO-95	VFAP-1612	VCA-1157	VG-16
V6 2.5L (L) FI	VO-88	VFAP-1613	VCA-1157	VG-16

Se reporter à table de matière pour les notes en bas de page en français. Utilize el contenido para ver notas a pie.

NS - Non-Serviceable / Non réparable / No reparable LF - Life-Time Filter / Filtro para toda la vida / Filtre à vie

^{X388}Conical air. ^{Y388}Panel air. ^{Z388}Conical air without dome.



MERCURY (cont'd)

1995

Sable

V6 3.0L (U) FI	VO-118	VA-66		VG-16
V6 3.8L (4) FI	VO-118	VA-66		VG-16

Tracer

4 cyl. 1.8L (8) FI	VO-106	VA-416		VG-16
4 cyl. 1.9L (J) FI	VO-118	VA-69		VG-16

Villager

V6 3.0L FI	VO-25	VFAP-7857		
------------	-------	-----------	--	--

MINI

2019

Cooper

3 cyl. 1.5L Turbo	VO-166			NS ⁴⁵⁰
4 cyl. 2.0L Turbo	VO-166			NS ⁴⁵⁰

Cooper Clubman

3 cyl. 1.5L	VO-166			NS
4 cyl. 2.0L	VO-166			NS

Cooper Countryman

3 cyl. 1.5L Turbo	VO-166			NS
4 cyl. 2.0L Turbo	VO-166			NS

2018

Cooper

3 cyl. 1.5L Turbo	VO-166			NS ⁴⁵⁰
4 cyl. 2.0L Turbo	VO-166			NS ⁴⁵⁰

Cooper Clubman

3 cyl. 1.5L	VO-166			NS
4 cyl. 2.0L	VO-166			NS

Cooper Countryman

3 cyl. 1.5L Turbo	VO-166			NS
4 cyl. 2.0L Turbo	VO-166			NS

2017

Cooper

3 cyl. 1.5L Turbo	VO-166			NS ⁴⁵⁰
4 cyl. 2.0L Turbo	VO-166			NS ⁴⁵⁰

Cooper Clubman

3 cyl. 1.5L	VO-166			NS
4 cyl. 2.0L	VO-166			NS

Cooper Countryman

3 cyl. 1.5L Turbo	VO-166			NS
4 cyl. 2.0L Turbo	VO-166			NS

2016

Cooper

3 cyl. 1.5L Turbo	VO-166			NS
4 cyl. 2.0L Turbo	VO-166			NS

Cooper Clubman

3 cyl. 1.5L	VO-166			NS
4 cyl. 2.0L	VO-166			NS

Cooper Countryman

4 cyl. 1.6L FI Non Turbo	VO-111	VA-316 ^{X348} VA-326 ^{Z348}		NS ⁴³⁷
--------------------------	--------	--	--	-------------------

4 cyl. 1.6L FI Turbo	VO-111	VA-447		NS ⁴³⁷
----------------------	--------	--------	--	-------------------

Cooper Paceman

L4 1.6	VO-111	VA-316		NS ⁴³⁷
--------	--------	--------	--	-------------------

Se reporter à table de matière pour les notes en bas de page en français. Utilize el contenido para ver notas a pie.

NS - Non-Serviceable / Non réparable / No repairable LF - Life-Time Filter / Filtro para toda la vida / Filtre à vie

⁴³⁷ Requires replacement of the complete fuel pump/fuel filter module. ⁴⁵⁰ Lifetime filter. Does not require replacement under normal conditions. ^{X348}A.T.

^{Z348}M.T.



MINI (cont'd)

	Oil	Air	Cabin*	Fuel
2016				
Cooper Paceman S				
L4 1.6 Turbo	VO-111	VA-447		NS ⁴³⁷
2015				
Cooper				
3 cyl. 1.5L Turbo	VO-166			NS
4 cyl. 1.6L	VO-111	VA-316 ^{X348} VA-326 ^{Z348}		NS ⁴³⁷
4 cyl. 2.0L Turbo	VO-166			NS
Cooper Countryman				
4 cyl. 1.6L FI Non Turbo	VO-111	VA-316 ^{X348} VA-326 ^{Z348}		NS ⁴³⁷
4 cyl. 1.6L FI Turbo	VO-111	VA-447		NS ⁴³⁷
Cooper Paceman				
L4 1.6	VO-111	VA-316		NS ⁴³⁷
Cooper Paceman S				
L4 1.6 Turbo	VO-111	VA-447		NS ⁴³⁷
Cooper S				
4 cyl. 1.6L FI Turbo	VO-111	VA-447		NS ⁴³⁷
2014				
Cooper				
4 cyl. 1.6L FI	VO-111	VA-316 ^{X348} VA-326 ^{Z348}		NS ⁴³⁷
4 cyl. 1.6L FI (Clubman)	VO-111	VA-316 ^{X348} VA-326 ^{Z348}		NS ⁴³⁷
Cooper Countryman				
4 cyl. 1.6L FI Non Turbo	VO-111	VA-316 ^{X348} VA-326 ^{Z348}		NS ⁴³⁷
4 cyl. 1.6L FI Turbo	VO-111	VA-447		NS ⁴³⁷
Cooper Paceman				
L4 1.6	VO-111	VA-316		NS ⁴³⁷
Cooper Paceman S				
L4 1.6 Turbo	VO-111	VA-447		NS ⁴³⁷
Cooper S				
4 cyl. 1.6L FI Turbo	VO-111	VA-447		NS ⁴³⁷
2013				
Cooper				
4 cyl. 1.6L FI	VO-111	VA-316 ^{X348} VA-326 ^{Z348}		NS ⁴³⁷
4 cyl. 1.6L FI (Clubman)	VO-111	VA-316 ^{X348} VA-326 ^{Z348}		NS ⁴³⁷
Cooper Countryman				
4 cyl. 1.6L FI Non Turbo	VO-111	VA-316 ^{X348} VA-326 ^{Z348}		NS ⁴³⁷
4 cyl. 1.6L FI Turbo	VO-111	VA-447		NS ⁴³⁷
Cooper Paceman				
L4 1.6	VO-111	VA-316		NS ⁴³⁷
Cooper Paceman S				
L4 1.6 Turbo	VO-111	VA-447		NS ⁴³⁷
Cooper S				
4 cyl. 1.6L FI Turbo	VO-111	VA-447		NS ⁴³⁷
4 cyl. 1.6L FI Turbo (Clubman)	VO-111	VA-447		NS ⁴³⁷
4 cyl. 1.6L FI Turbo (JCW)	VO-111	VA-447		NS ⁴³⁷

Se reporter à table de matière pour les notes en bas de page en français. Utilize el contenido para ver notas a pie.

NS - Non-Serviceable / Non réparable / No reparable LF - Life-Time Filter / Filtro para toda la vida / Filtre à vie

⁴³⁷ Requires replacement of the complete fuel pump/fuel filter module. ^{X348}A.T. ^{Z348}M.T.



MINI (cont'd)

2012

Cooper

4 cyl. 1.6L FI	VO-111	VA-316 ^{X348} VA-326 ^{Z348}		NS ⁴³⁷
4 cyl. 1.6L FI (Clubman)	VO-111	VA-316 ^{X348} VA-326 ^{Z348}		NS ⁴³⁷

Cooper Countryman

4 cyl. 1.6L FI Non Turbo	VO-111	VA-316 ^{X348} VA-326 ^{Z348}		NS ⁴³⁷
4 cyl. 1.6L FI Turbo	VO-111	VA-447		NS ⁴³⁷

Cooper S

4 cyl. 1.6L FI Turbo	VO-111	VA-447		NS ⁴³⁷
4 cyl. 1.6L FI Turbo (JCW)	VO-111			NS ⁴³⁷

2011

Cooper

4 cyl. 1.6L FI	VO-111	VA-316 ^{X348} VA-326 ^{Z348}		NS ⁴³⁷
4 cyl. 1.6L FI (Clubman)	VO-111	VA-316 ^{X348} VA-326 ^{Z348}		NS ⁴³⁷

Cooper Countryman

4 cyl. 1.6L FI Non Turbo	VO-111	VA-316 ^{X348} VA-326 ^{Z348}		NS ⁴³⁷
4 cyl. 1.6L FI Turbo	VO-111	VA-447		NS ⁴³⁷

Cooper S

4 cyl. 1.6L FI Turbo	VO-111	VA-447		NS ⁴³⁷
4 cyl. 1.6L FI Turbo (JCW)	VO-111			NS ⁴³⁷

2010

Cooper

4 cyl. 1.6L FI	VO-111	VA-316 ^{X348} VA-326 ^{Z348}		NS ⁴³⁷
4 cyl. 1.6L FI (Clubman)	VO-111	VA-316 ^{X348} VA-326 ^{Z348}		NS ⁴³⁷

Cooper S

4 cyl. 1.6L FI Turbo	VO-111	VA-447		NS ⁴³⁷
4 cyl. 1.6L FI Turbo (JCW)	VO-111			NS ⁴³⁷

2009

Cooper

4 cyl. 1.6L FI	VO-111	VA-316 ^{X348} VA-326 ^{Z348}		NS ⁴³⁷
4 cyl. 1.6L FI (Clubman)	VO-111	VA-316 ^{X348} VA-326 ^{Z348}		NS ⁴³⁷

Cooper S

4 cyl. 1.6L FI Turbo	VO-111	VA-447		NS ⁴³⁷
4 cyl. 1.6L FI Turbo (JCW)	VO-111			NS ⁴³⁷

2008

Cooper

4 cyl. 1.6L FI (Clubman)	VO-111	VA-316 ^{X348} VA-326 ^{Z348}		NS ⁴³⁷
--------------------------	--------	--	--	-------------------

Cooper (Convertible)

4 cyl 1.6L FI	VO-82	VA-199	VCA-1056	NS ⁴³⁷
---------------	-------	--------	----------	-------------------

Cooper (Coupe)

4 cyl. 1.6L FI	VO-111	VA-316 ^{X348} VA-326 ^{Z348}		NS ⁴³⁷
----------------	--------	--	--	-------------------

Se reporter à table de matière pour les notes en bas de page en français. Utilize el contenido para ver notas a pie.

NS - Non-Serviceable / Non réparable / No reparable LF - Life-Time Filter / Filtro para toda la vida / Filtre à vie

⁴³⁷ Requires replacement of the complete fuel pump/fuel filter module. ^{X348}A.T. ^{Z348}M.T.



MINI (cont'd)

	Oil	Air	Cabin*	Fuel
2008				
Cooper S Clubman				
L4 1.6 FI (S.C.)	VO-111	VA-447		NS ⁴³⁷
Cooper S (Convertible)				
4 cyl. 1.6L FI (S.C.)	VO-82	VA-355	VCA-1056	NS ⁴³⁷
Cooper S (Coupe)				
4 cyl. 1.6L FI Turbo	VO-111	VA-447		NS ⁴³⁷
2007				
Cooper (Convertible)				
4 cyl. 1.6L FI	VO-82	VA-199	VCA-1056	NS ⁴³⁷
Cooper (Coupe)				
4 cyl. 1.6L FI	VO-111	VA-316 ^{X348} VA-326 ^{Z348}		NS ⁴³⁷
Cooper S (Convertible)				
4 cyl. 1.6L FI (S.C.)	VO-82	VA-355	VCA-1056	NS ⁴³⁷
Cooper S (Coupe)				
4 cyl. 1.6L FI Turbo	VO-111	VA-447		NS ⁴³⁷
2006				
Cooper				
4 cyl. 1.6L FI	VO-82	VA-199 ⁸⁷³	VCA-1056	NS ⁴³⁷
Cooper S				
4 cyl. 1.6L FI (S.C.)	VO-82	VA-355	VCA-1056	NS ⁴³⁷
2005				
Cooper				
4 cyl. 1.6L FI	VO-82	VA-199	VCA-1056	NS ⁴³⁷
Cooper S				
4 cyl. 1.6L FI (S.C.)	VO-82	VA-355	VCA-1056	NS ⁴³⁷
2004				
Cooper				
4 cyl. 1.6L FI	VO-82	VA-199	VCA-1056	NS ⁴³⁷
Cooper S				
4 cyl. 1.6L FI (S.C.)	VO-82	VA-355	VCA-1056	NS ⁴³⁷
2003				
Cooper				
4 cyl. 1.6L FI	VO-82	VA-199	VCA-1056	NS ⁴³⁷
Cooper S				
4 cyl. 1.6L FI (S.C.)	VO-82	VA-355	VCA-1056	NS ⁴³⁷
2002				
Cooper				
4 cyl. 1.6L FI	VO-82	VA-199	VCA-1056	NS ⁴³⁷
Cooper S				
4 cyl. 1.6L FI (S.C.)	VO-82	VA-355	VCA-1056	NS ⁴³⁷

MITSUBISHI

2019				
Eclipse Cross				
4 cyl. 1.5L Turbo	VO-106		VCA-1068	NS ⁴³⁷
Mirage				
3 cyl. 1.2L	VO-106			NS ⁴³⁷
Outlander				
4 cyl. 2.4L	VO-106	VA-437	VCA-1068	NS ⁴³⁷
V6 3.0L	VO-106	VA-437	VCA-1068	NS ⁴³⁷

Se reporter à table de matière pour les notes en bas de page en français. Utilize el contenido para ver notas a pie.

NS - Non-Serviceable / Non réparable / No reparable LF - Life-Time Filter / Filtro para toda la vida / Filtre à vie

⁴³⁷ Requires replacement of the complete fuel pump/fuel filter module. ⁸⁷³ with rectangular air box. ^{X348}A.T. ^{Z348}M.T.



MITSUBISHI (cont'd)

2019

Outlander PHEV

4 cyl. 2.0	VO-106		VCA-1068	NS ⁴³⁷
------------	--------	--	----------	-------------------

Outlander Sport

4 cyl. 2.0L	VO-106	VA-437	VCA-1068	NS ⁴³⁷
-------------	--------	--------	----------	-------------------

4 cyl. 2.4L	VO-106	VA-437	VCA-1068	NS ⁴³⁷
-------------	--------	--------	----------	-------------------

RVR (Canada)

4 cyl. 2.0L	VO-106	VA-437	VCA-1068	NS ⁴³⁷
-------------	--------	--------	----------	-------------------

4 cyl. 2.4L	VO-106	VA-437	VCA-1068	NS ⁴³⁷
-------------	--------	--------	----------	-------------------

2018

Eclipse Cross

4 cyl. 1.5L Turbo	VO-106		VCA-1068	NS ⁴³⁷
-------------------	--------	--	----------	-------------------

Mirage

3 cyl. 1.2L	VO-106			NS ⁴³⁷
-------------	--------	--	--	-------------------

Outlander

4 cyl 2.4L	VO-106	VA-437	VCA-1068	NS ⁴³⁷
------------	--------	--------	----------	-------------------

V6 3.0L	VO-106	VA-437	VCA-1068	NS ⁴³⁷
---------	--------	--------	----------	-------------------

Outlander PHEV

4 cyl. 2.0	VO-106		VCA-1068	NS ⁴³⁷
------------	--------	--	----------	-------------------

Outlander Sport

4 cyl. 2.0L	VO-106	VA-437	VCA-1068	NS ⁴³⁷
-------------	--------	--------	----------	-------------------

4 cyl. 2.4L	VO-106	VA-437	VCA-1068	NS ⁴³⁷
-------------	--------	--------	----------	-------------------

RVR (Canada)

4 cyl. 2.0L	VO-106	VA-437	VCA-1068	NS ⁴³⁷
-------------	--------	--------	----------	-------------------

4 cyl. 2.4L	VO-106	VA-437	VCA-1068	NS ⁴³⁷
-------------	--------	--------	----------	-------------------

2017

Lancer

4 cyl. 2.0L (U)	VO-106	VA-437	VCA-1068	NS ⁴³⁷
-----------------	--------	--------	----------	-------------------

4 cyl. 2.4L (W)	VO-106	VA-437	VCA-1068	NS ⁴³⁷
-----------------	--------	--------	----------	-------------------

Mirage

3 cyl. 1.2L	VO-106			NS ⁴³⁷
-------------	--------	--	--	-------------------

Outlander

4 cyl 2.4L	VO-106	VA-437	VCA-1068	NS ⁴³⁷
------------	--------	--------	----------	-------------------

V6 3.0L	VO-106	VA-437	VCA-1068	NS ⁴³⁷
---------	--------	--------	----------	-------------------

Outlander Sport

4 cyl. 2.0L	VO-106	VA-437	VCA-1068	NS ⁴³⁷
-------------	--------	--------	----------	-------------------

4 cyl. 2.4L	VO-106	VA-437	VCA-1068	NS ⁴³⁷
-------------	--------	--------	----------	-------------------

RVR (Canada)

4 cyl. 2.0L	VO-106	VA-437	VCA-1068	NS ⁴³⁷
-------------	--------	--------	----------	-------------------

4 cyl. 2.4L	VO-106	VA-437	VCA-1068	NS ⁴³⁷
-------------	--------	--------	----------	-------------------

2016

Lancer

4 cyl. 2.0L (U)	VO-106	VA-437	VCA-1068	NS ⁴³⁷
-----------------	--------	--------	----------	-------------------

4 cyl. 2.4L (W)	VO-106	VA-437	VCA-1068	NS ⁴³⁷
-----------------	--------	--------	----------	-------------------

Outlander

4 cyl 2.4L	VO-106	VA-437	VCA-1068	NS ⁴³⁷
------------	--------	--------	----------	-------------------

V6 3.0L	VO-106	VA-437	VCA-1068	NS ⁴³⁷
---------	--------	--------	----------	-------------------

Outlander Sport

4 cyl. 2.0L	VO-106	VA-437	VCA-1068	NS ⁴³⁷
-------------	--------	--------	----------	-------------------

4 cyl. 2.4L	VO-106	VA-437	VCA-1068	NS ⁴³⁷
-------------	--------	--------	----------	-------------------

RVR (Canada)

4 cyl. 2.0L	VO-106	VA-437	VCA-1068	NS ⁴³⁷
-------------	--------	--------	----------	-------------------

4 cyl. 2.4L	VO-106	VA-437	VCA-1068	NS ⁴³⁷
-------------	--------	--------	----------	-------------------

Se reporter à table de matière pour les notes en bas de page en français. Utilize el contenido para ver notas a pie.

NS - Non-Serviceable / Non réparable / No reparable LF - Life-Time Filter / Filtro para toda la vida / Filtre à vie

⁴³⁷ Requires replacement of the complete fuel pump/fuel filter module.



MITSUBISHI (cont'd)

	Oil	Air	Cabin*	Fuel
2015				
Lancer				
4 cyl. 2.0L (U) Non turbo	VO-106	VA-437	VCA-1068	NS ⁴³⁷
4 cyl. 2.0L (V) Turbo	VO-106	VA-278	VCA-1068	NS ⁴³⁷
4 cyl. 2.4L (W)	VO-106	VA-437	VCA-1068	NS ⁴³⁷
Mirage				
3 cyl. 1.2L	VO-106			NS ⁴³⁷
Outlander				
4 cyl. 2.4L	VO-106	VA-437	VCA-1068	NS ⁴³⁷
V6 3.0L	VO-106	VA-437	VCA-1068	NS ⁴³⁷
Outlander Sport				
4 cyl. 2.0L	VO-106	VA-437	VCA-1068	NS ⁴³⁷
4 cyl. 2.4L	VO-106	VA-437	VCA-1068	NS ⁴³⁷
RVR (Canada)				
4 cyl. 2.0L	VO-106	VA-437	VCA-1068	NS ⁴³⁷
4 cyl. 2.4L	VO-106	VA-437	VCA-1068	NS ⁴³⁷
2014				
Lancer				
4 cyl. 2.0L (U) Non turbo	VO-106	VA-437	VCA-1068	NS ⁴³⁷
4 cyl. 2.0L (V) Turbo	VO-106	VA-278	VCA-1068	NS ⁴³⁷
4 cyl. 2.4L (W)	VO-106	VA-437	VCA-1068	NS ⁴³⁷
Mirage				
3 cyl. 1.2L	VO-106			NS ⁴³⁷
Outlander				
4 cyl. 2.4L	VO-106	VA-437	VCA-1068	NS ⁴³⁷
V6 3.0L	VO-106	VA-437	VCA-1068	NS ⁴³⁷
Outlander Sport				
4 cyl. 2.0L	VO-106	VA-437	VCA-1068	NS ⁴³⁷
RVR (Canada)				
4 cyl. 2.0L	VO-106	VA-437	VCA-1068	NS ⁴³⁷
2013				
Lancer				
4 cyl. 2.0L (U) Non turbo	VO-106	VA-278 ^{X871} VA-437 ^{Z871}	VCA-1068	NS ⁴³⁷
4 cyl. 2.0L (V) Turbo	VO-106	VA-278	VCA-1068	NS ⁴³⁷
4 cyl. 2.4L (W)	VO-106	VA-278	VCA-1068	NS ⁴³⁷
Outlander				
4 cyl. 2.4L	VO-106	VA-278	VCA-1068	NS ⁴³⁷
V6 3.0L	VO-106	VA-278	VCA-1068	NS ⁴³⁷
Outlander Sport				
4 cyl. 2.0L	VO-106	VA-437	VCA-1068	NS ⁴³⁷
RVR (Canada)				
4 cyl. 2.0L	VO-106	VA-437	VCA-1068	NS ⁴³⁷
2012				
Eclipse, Eclipse Spyder				
4 cyl. 2.4L (F) FI	VO-106	VA-206		NS ⁴³⁷
V6 3.8L (T) FI	VO-106	VA-206		NS ⁴³⁷
Galant				
4 cyl. 2.4L (F) FI	VO-106	VA-206	VCA-1014 ¹¹³⁴	NS ⁴³⁷
Lancer				
4 cyl. 2.0L (U) Non turbo	VO-106	VA-278	VCA-1068	NS ⁴³⁷
4 cyl. 2.0L (V) Turbo	VO-106	VA-278	VCA-1068	NS ⁴³⁷
4 cyl. 2.4L (W)	VO-106	VA-278	VCA-1068	NS ⁴³⁷

Se reporter à table de matière pour les notes en bas de page en français. Utilize el contenido para ver notas a pie.

NS - Non-Serviceable / Non réparable / No reparable LF - Life-Time Filter / Filtro para toda la vida / Filtre à vie

⁴³⁷ Requires replacement of the complete fuel pump/fuel filter module. ¹¹³⁴Dust Filter. Replace with VCA-1032 when stock is depleted. ^{X871}with 7.28 inch wide filter

^{Z871}with 8.12 inch wide filter



MITSUBISHI (cont'd)

2012

Outlander

4 cyl 2.4L	VO-106	VA-278	VCA-1068	NS ⁴³⁷
V6 3.0L	VO-106	VA-278	VCA-1068	NS ⁴³⁷

Outlander Sport

4 cyl. 2.0L	VO-106	VA-278	VCA-1068	NS ⁴³⁷
-------------	--------	--------	----------	-------------------

RVR (Canada)

4 cyl. 2.0L	VO-106	VA-278	VCA-1068	NS ⁴³⁷
-------------	--------	--------	----------	-------------------

2011

Eclipse, Eclipse Spyder

4 cyl. 2.4L (F) FI	VO-106	VA-206		NS ⁴³⁷
V6 3.8L (T) FI	VO-106	VA-206		NS ⁴³⁷

Endeavor

V6 3.8L FI	VO-106	VA-206	VCA-1014 ¹¹³⁴	NS ⁴³⁷
------------	--------	--------	--------------------------	-------------------

Galant

4 cyl. 2.4L (F) FI	VO-106	VA-206	VCA-1014 ¹¹³⁴	NS ⁴³⁷
--------------------	--------	--------	--------------------------	-------------------

Lancer

4 cyl. 2.0L (U) Non turbo	VO-106	VA-278	VCA-1068	NS ⁴³⁷
4 cyl. 2.0L (V) Turbo	VO-106	VA-278	VCA-1068	NS ⁴³⁷
4 cyl. 2.4L (W)	VO-106	VA-278	VCA-1068	NS ⁴³⁷

Outlander

4 cyl 2.4L	VO-106	VA-278	VCA-1068	NS ⁴³⁷
V6 3.0L	VO-106	VA-278	VCA-1068	NS ⁴³⁷

Outlander Sport

4 cyl. 2.0L	VO-106	VA-278	VCA-1068	NS ⁴³⁷
-------------	--------	--------	----------	-------------------

RVR (Canada)

4 cyl. 2.0L	VO-106	VA-278	VCA-1068	NS ⁴³⁷
-------------	--------	--------	----------	-------------------

2010

Eclipse, Eclipse Spyder

4 cyl. 2.4L (F) FI	VO-106	VA-206		NS ⁴³⁷
V6 3.8L (T) FI	VO-106	VA-206		NS ⁴³⁷

Endeavor

V6 3.8L FI	VO-106	VA-206	VCA-1014 ¹¹³⁴	NS ⁴³⁷
------------	--------	--------	--------------------------	-------------------

Galant

4 cyl. 2.4L (F) FI	VO-106	VA-206	VCA-1014 ¹¹³⁴	NS ⁴³⁷
--------------------	--------	--------	--------------------------	-------------------

Lancer

4 cyl. 2.0L (U) FI Non Turbo	VO-106	VA-278	VCA-1068	NS ⁴³⁷
4 cyl. 2.0L (V) FI Turbo	VO-106	VA-278	VCA-1068	NS ⁴³⁷
4 cyl. 2.4L (W) FI	VO-106	VA-278	VCA-1068	NS ⁴³⁷

Outlander

4 cyl 2.4L	VO-106	VA-278	VCA-1068	NS ⁴³⁷
V6 3.0L	VO-106	VA-278	VCA-1068	NS ⁴³⁷

2009

Eclipse, Eclipse Spyder

4 cyl. 2.4L (F) FI	VO-106	VA-206		NS ⁴³⁷
V6 3.8L (T) FI	VO-106	VA-206		NS ⁴³⁷

Galant

4 cyl. 2.4L (F) FI	VO-106	VA-206	VCA-1014 ¹¹³⁴	NS ⁴³⁷
V6 3.8L (S,T) FI	VO-106	VA-206	VCA-1014 ¹¹³⁴	NS ⁴³⁷

Lancer

4 cyl. 2.0L (U) FI Non Turbo	VO-106	VA-278	VCA-1068	NS ⁴³⁷
4 cyl. 2.0L (V) FI Turbo	VO-106	VA-278	VCA-1068	NS ⁴³⁷
4 cyl. 2.4L (W) FI	VO-106	VA-278	VCA-1068	NS ⁴³⁷

Se reporter à table de matière pour les notes en bas de page en français. Utilize el contenido para ver notas a pie.

NS - Non-Serviceable / Non réparable / No reparable LF - Life-Time Filter / Filtro para toda la vida / Filtre à vie

⁴³⁷ Requires replacement of the complete fuel pump/fuel filter module. ¹¹³⁴Dust Filter. Replace with VCA-1032 when stock is depleted.



MITSUBISHI (cont'd)

	Oil	Air	Cabin*	Fuel
2009				
Outlander				
4 cyl. 2.4L	VO-106	VA-278	VCA-1068	NS ⁴³⁷
V6 3.0L	VO-106	VA-278	VCA-1068	NS ⁴³⁷
Raider				
V6 3.7L (K) FI	VO-88	VA-90		NS ⁴³⁷
2008				
Eclipse, Eclipse Spyder				
4 cyl. 2.4L (F) FI	VO-106	VA-206		NS ⁴³⁷
V6 3.8L (T) FI	VO-106	VA-206		NS ⁴³⁷
Endeavor				
V6 3.8L FI	VO-106	VA-206	VCA-1014 ¹¹³⁴	NS ⁴³⁷
Galant				
4 cyl. 2.4L (F) FI	VO-106	VA-206	VCA-1014 ¹¹³⁴	NS ⁴³⁷
V6 3.8L (T) FI	VO-106	VA-206	VCA-1014 ¹¹³⁴	NS ⁴³⁷
Lancer				
4 cyl. 2.0L (U) FI Non Turbo	VO-106	VA-278	VCA-1068	NS ⁴³⁷
4 cyl. 2.0L (V) FI Turbo	VO-106	VA-278	VCA-1068	NS ⁴³⁷
Outlander				
4 cyl. 2.4L	VO-106	VA-278	VCA-1068	NS ⁴³⁷
V6 3.0L	VO-106	VA-278	VCA-1068	NS ⁴³⁷
Raider				
V6 3.7L (K) FI	VO-118	VA-90		NS ⁴³⁷
2007				
Eclipse, Eclipse Spyder				
4 cyl. 2.4L (F) FI	VO-106	VA-206		NS ⁴³⁷
V6 3.8L (T) FI	VO-106	VA-206		NS ⁴³⁷
Endeavor				
V6 3.8L FI	VO-106	VA-206	VCA-1014 ¹¹³⁴	NS ⁴³⁷
Galant				
4 cyl. 2.4L (F) FI	VO-106	VA-206	VCA-1014 ¹¹³⁴	NS ⁴³⁷
V6 3.8L (S,T) FI	VO-106	VA-206	VCA-1014 ¹¹³⁴	NS ⁴³⁷
Lancer				
4 cyl. 2.0L (E) FI Non Turbo	VO-106	VA-153	VCA-1147	NS ⁴³⁷
Outlander				
V6 3.0L FI	VO-106	VA-278	VCA-1068	NS ⁴³⁷
Raider				
V6 3.7L (K) FI	VO-118	VA-90		NS ⁴³⁷
V8 4.7L (N) FI	VO-95 ^{X504} VO-25 ^{Z504}	VA-90		NS ⁴³⁷
2006				
Eclipse				
4 cyl. 2.4L (F) FI	VO-106	VA-206		NS ⁴³⁷
V6 3.8L (T) FI	VO-106	VA-206		NS ⁴³⁷
Endeavor				
V6 3.8L FI	VO-106	VA-206	VCA-1014 ¹¹³⁴	NS ⁴³⁷
Galant				
4 cyl. 2.4L (F) FI	VO-106	VA-206	VCA-1014 ¹¹³⁴	NS ⁴³⁷
V6 3.8L (S) FI	VO-106	VA-206	VCA-1014 ¹¹³⁴	NS ⁴³⁷
Lancer				
4 cyl. 2.0L (E) FI Non Turbo	VO-106	VA-153	VCA-1147	NS ⁴³⁷
4 cyl. 2.0L (C) FI Turbo	VO-106	VA-153	VCA-1147	NS ⁴³⁷
4 cyl. 2.4L (F) FI	VO-106	VA-153	VCA-1147	NS ⁴³⁷

Se reporter à table de matière pour les notes en bas de page en français. Utilize el contenido para ver notas a pie.

NS - Non-Serviceable / Non réparable / No reparable LF - Life-Time Filter / Filtro para toda la vida / Filtre à vie

⁴³⁷ Requires replacement of the complete fuel pump/fuel filter module. ¹¹³⁴Dust Filter. Replace with VCA-1032 when stock is depleted. ^{X504}Alternate

^{Z504}Primary



MITSUBISHI (cont'd)

2006

Montero

V6 3.8L FI	VO-106			NS ⁴³⁷
------------	--------	--	--	-------------------

Outlander

4 cyl. 2.4L FI	VO-106	VA-153	VCA-1147	NS ⁴³⁷
----------------	--------	--------	----------	-------------------

Raider

V6 3.7L (K) FI	VO-118	VA-90		NS ⁴³⁷
V8 4.7L (N) FI	VO-95 ^{X504} VO-25 ^{Z504}	VA-90		NS ⁴³⁷

2005

Eclipse, Eclipse Spyder

4 cyl. 2.4L (G) FI	VO-106	VA-104	VCA-1113	NS ⁴³⁷
V6 3.0L (H) FI	VO-106	VA-104	VCA-1113	NS ⁴³⁷

Endeavor

V6 3.8L FI	VO-106	VA-206	VCA-1014 ¹¹³⁴	NS ⁴³⁷
------------	--------	--------	--------------------------	-------------------

Galant

4 cyl. 2.4L (F) FI	VO-106	VA-206	VCA-1014 ¹¹³⁴	NS ⁴³⁷
V6 3.8L (S) FI	VO-106	VA-206	VCA-1014 ¹¹³⁴	NS ⁴³⁷

Lancer

4 cyl. 2.0L (E) FI Non Turbo	VO-106	VA-153	VCA-1147	NS ⁴³⁷
4 cyl. 2.0L (D) FI Turbo	VO-106	VA-153	VCA-1147	NS ⁴³⁷
4 cyl. 2.4L (F) FI	VO-106	VA-153	VCA-1147	NS ⁴³⁷

Montero

V6 3.8L FI	VO-106			NS ⁴³⁷
------------	--------	--	--	-------------------

Outlander

4 cyl. 2.4L FI	VO-106	VA-153	VCA-1147	NS ⁴³⁷
----------------	--------	--------	----------	-------------------

2004

Diamante

V6 3.5L FI	VO-106			
------------	--------	--	--	--

Eclipse, Eclipse Spyder

4 cyl. 2.4L (G) FI	VO-106	VA-104	VCA-1113	NS ⁴³⁷
V6 3.0L (H) FI	VO-106	VA-104	VCA-1113	NS ⁴³⁷

Endeavor

V6 3.8L FI	VO-106	VA-206	VCA-1014 ¹¹³⁴	NS ⁴³⁷
------------	--------	--------	--------------------------	-------------------

Galant

4 cyl. 2.4L FI	VO-106	VA-206	VCA-1014 ¹¹³⁴	NS ⁴³⁷
V6 3.8L FI	VO-106	VA-206	VCA-1014 ¹¹³⁴	NS ⁴³⁷

Lancer

4 cyl. 2.0L FI Non Turbo	VO-106	VA-153	VCA-1147	NS ⁴³⁷
4 cyl. 2.0L FI Turbo	VO-106	VA-153	VCA-1147	NS ⁴³⁷
4 cyl. 2.4L FI	VO-106	VA-153	VCA-1147	NS ⁴³⁷

Montero

V6 3.8L FI	VO-106			NS ⁴³⁷
------------	--------	--	--	-------------------

Montero Sport

V6 3.5L (R) FI	VO-106	VA-128		
----------------	--------	--------	--	--

Outlander

4 cyl. 2.4L FI	VO-106	VA-153	VCA-1147	NS ⁴³⁷
----------------	--------	--------	----------	-------------------

2003

Diamante

V6 3.5L FI	VO-106			
------------	--------	--	--	--

Eclipse, Eclipse Spyder

4 cyl. 2.4L (G) FI	VO-106	VA-104	VCA-1113	NS ⁴³⁷
V6 3.0L (H) FI	VO-106	VA-104	VCA-1113	NS ⁴³⁷

Se reporter à table de matière pour les notes en bas de page en français. Utilize el contenido para ver notas a pie.

NS - Non-Serviceable / Non réparable / No reparable LF - Life-Time Filter / Filtro para toda la vida / Filtre à vie

⁴³⁷ Requires replacement of the complete fuel pump/fuel filter module. ¹¹³⁴Dust Filter. Replace with VCA-1032 when stock is depleted. ^{X504}Alternate

^{Z504}Primary



MITSUBISHI (cont'd)

	Oil	Air	Cabin*	Fuel
2003				
Galant				
4 cyl. 2.4L (G) FI	VO-106	VA-104	VCA-1113	NS ⁴³⁷
V6 3.0L (H) FI	VO-106	VA-104	VCA-1113	NS ⁴³⁷
Lancer				
4 cyl. 2.0L FI Non Turbo	VO-106	VA-153	VCA-1147	NS ⁴³⁷
4 cyl. 2.0L FI Turbo	VO-106	VA-153	VCA-1147	NS ⁴³⁷
Montero				
V6 3.8L FI	VO-106			NS ⁴³⁷
Montero Sport				
V6 3.0L (H) FI	VO-106	VA-99		
V6 3.5L (R) FI	VO-106	VA-128		
Outlander				
4 cyl. 2.4L FI	VO-106	VA-153	VCA-1147	NS ⁴³⁷
2002				
Diamante				
V6 3.5L FI	VO-106			
Eclipse, Eclipse Spyder				
4 cyl. 2.4L (G) FI	VO-106	VA-104	VCA-1113	NS ⁴³⁷
V6 3.0L (H) FI	VO-106	VA-104	VCA-1113	NS ⁴³⁷
Galant				
4 cyl. 2.4L (G) FI	VO-106	VA-104	VCA-1113	NS ⁴³⁷
V6 3.0L (L) FI	VO-106	VA-104	VCA-1113	NS ⁴³⁷
Lancer				
4 cyl. 2.0L FI	VO-106	VA-153	VCA-1147	NS ⁴³⁷
Mirage				
4 cyl. 1.5L (A) FI	VO-106	VA-153		
4 cyl. 1.8L (C) FI	VO-106	VA-153		
Montero				
V6 3.5L FI	VO-106			NS ⁴³⁷
Montero Sport				
V6 3.0L (H) FI	VO-106	VA-99		
V6 3.5L (R) FI	VO-106	VA-128		
2001				
Diamante				
V6 3.5L FI	VO-106			
Eclipse, Eclipse Spyder				
4 cyl. 2.4L (G) FI	VO-106	VA-104	VCA-1113	NS ⁴³⁷
V6 3.0L (H) FI	VO-106	VA-104	VCA-1113	NS ⁴³⁷
Galant				
4 cyl. 2.4L (G) FI	VO-106	VA-104	VCA-1113	NS ⁴³⁷
V6 3.0L (H) FI	VO-106	VA-104	VCA-1113	NS ⁴³⁷
Mirage				
4 cyl. 1.5L (A) FI	VO-106	VA-153		
4 cyl. 1.8L (C) FI	VO-106	VA-153		
Montero				
V6 3.5L FI	VO-106			NS ⁴³⁷
Montero Sport				
V6 3.0L (H) FI	VO-106	VA-99		
V6 3.5L (R) FI	VO-106	VA-128		
2000				
Diamante				
V6 3.5L FI	VO-106			

Se reporter à table de matière pour les notes en bas de page en français. Utilize el contenido para ver notas a pie.

NS - Non-Serviceable / Non réparable / No reparable LF - Life-Time Filter / Filtro para toda la vida / Filtre à vie

⁴³⁷ Requires replacement of the complete fuel pump/fuel filter module.



MITSUBISHI (cont'd)

2000

Eclipse

4 cyl. 2.4L (G) FI	VO-106	VA-104	VCA-1113	NS ⁴³⁷
V6 3.0L (L) FI	VO-106	VA-104	VCA-1113	NS ⁴³⁷

Galant

4 cyl. 2.4L (G) FI	VO-106	VA-104	VCA-1113	NS ⁴³⁷
V6 3.0L (L) FI	VO-106	VA-104	VCA-1113	NS ⁴³⁷

Mirage

4 cyl. 1.5L (A) FI	VO-106	VA-153		
4 cyl. 1.8L (C) FI	VO-106	VA-153		

Montero

V6 3.5L FI	VO-106	VA-128		
------------	--------	--------	--	--

Montero Sport

V6 3.0L (H) FI	VO-106	VA-99		
V6 3.5L (R) FI	VO-106	VA-128		

1999

3000GT

V6 3.0L (J) FI Non Turbo DOHC	VO-106	VA-99		
V6 3.0L (H) FI Non Turbo SOHC	VO-106	VA-99		
V6 3.0L (K) FI Turbo	VO-106	VA-99		

Diamante

V6 3.5L FI	VO-106			
------------	--------	--	--	--

Eclipse

4 cyl. 2.0L (Y) FI Non Turbo	VO-95 ^{X504} VO-25 ^{Z504}	VA-104		
4 cyl. 2.0L FI Turbo	VO-106	VA-104		
4 cyl. 2.4L FI	VO-106	VA-104		

Galant

4 cyl. 2.4L FI	VO-106	VA-104	VCA-1113	NS ⁴³⁷
V6 3.0L FI	VO-106	VA-104	VCA-1113	NS ⁴³⁷

Mirage

4 cyl. 1.5L FI	VO-106	VA-153		
4 cyl. 1.8L FI	VO-106	VA-153		

Montero

V6 3.5L FI	VO-106	VA-128		
------------	--------	--------	--	--

Montero Sport

4 cyl. 2.4L FI	VO-106	VA-99		
V6 3.0L FI	VO-106	VA-99		
V6 3.5L FI	VO-106	VA-128		

1998

3000GT

V6 3.0L (J) FI Non Turbo DOHC	VO-106	VA-99		
V6 3.0L (H) FI Non Turbo SOHC	VO-106	VA-99		
V6 3.0L (K) FI Turbo	VO-106	VA-99		

Diamante

V6 3.5L FI	VO-106			
------------	--------	--	--	--

Eclipse

4 cyl. 2.0L (Y) FI Non Turbo	VO-95 ^{X504} VO-25 ^{Z504}	VA-104		
4 cyl. 2.0L (F) FI Turbo	VO-106	VA-104		
4 cyl. 2.4L (G) FI	VO-106	VA-104		

Galant

4 cyl. 2.4L (G) FI	VO-106	VA-104		
--------------------	--------	--------	--	--

Se reporter à table de matière pour les notes en bas de page en français. Utilize el contenido para ver notas a pie.

NS - Non-Serviceable / Non réparable / No reparable LF - Life-Time Filter / Filtro para toda la vida / Filtre à vie

⁴³⁷ Requires replacement of the complete fuel pump/fuel filter module. ^{X504}Alternate ^{Z504}Primary



MITSUBISHI (cont'd)

	Oil	Air	Cabin*	Fuel
1998				
Mirage				
4 cyl. 1.5L (A) FI	VO-106	VA-153		
4 cyl. 1.8L (C) FI	VO-106	VA-153		
Montero				
V6 3.5L FI	VO-106	VA-128		
Montero Sport				
4 cyl. 2.4L (G) FI	VO-106	VA-99		
V6 3.0L (P) FI	VO-106	VA-99		
1997				
3000GT				
V6 3.0L (J) FI Non Turbo DOHC	VO-106	VA-99		
V6 3.0L (H) FI Non Turbo SOHC	VO-106	VA-99		
V6 3.0L (K) FI Turbo	VO-106	VA-99		
Diamante				
V6 3.5L FI	VO-106			
Eclipse				
4 cyl. 2.0L (Y) FI Non Turbo	VO-95 ^{X504} VO-25 ^{Z504}	VA-104		
4 cyl. 2.0L (F) FI Turbo	VO-106	VA-104		
4 cyl. 2.4L (G) FI	VO-106	VA-104		
Galant				
4 cyl. 2.4L (G) FI	VO-106	VA-104		
Mirage				
4 cyl. 1.5L (A) FI	VO-106	VA-153		
4 cyl. 1.8L (C) FI	VO-106	VA-153		
Montero				
V6 3.5L FI	VO-106	VA-128		
Montero Sport				
4 cyl. 2.4L (G) FI	VO-106	VA-99		
V6 3.0L (P) FI	VO-106	VA-99		
1996				
3000GT				
V6 3.0L (J) FI Non Turbo	VO-106	VA-99		
V6 3.0L (K) FI Turbo	VO-106	VA-99		
Diamante				
V6 3.0L FI	VO-106	VA-99		
Eclipse				
4 cyl. 2.0L (F) FI Turbo	VO-106	VA-104		
4 cyl. 2.0L (Y) FI Non Turbo	VO-95 ^{X504} VO-25 ^{Z504}	VA-104		
4 cyl. 2.4L (G) FI	VO-106	VA-104		
Galant				
4 cyl. 2.4L (G) FI	VO-106	VA-104		
Mighty Max Pickup				
4 cyl. 2.4L (G) FI	VO-106	VA-99		
Mirage				
4 cyl. 1.5L (A) FI	VO-106	VA-387		
4 cyl. 1.8L (C) FI	VO-106	VA-387		
Montero				
V6 3.0L (H) FI	VO-106	VA-128		
V6 3.5L (M) FI	VO-106	VA-128		

Se reporter à table de matière pour les notes en bas de page en français. Utilize el contenido para ver notas a pie.

NS - Non-Serviceable / Non réparable / No reparable LF - Life-Time Filter / Filtro para toda la vida / Filtre à vie

^{X504}Alternate ^{Z504}Primary



MITSUBISHI (cont'd)

1995

3000GT

V6 3.0L (J) FI Non Turbo	VO-106	VA-99		
V6 3.0L (K) FI Turbo	VO-106	VA-99		

Diamante

V6 3.0L FI	VO-106	VA-99		
------------	--------	-------	--	--

Eclipse

4 cyl. 2.0L (Y) FI Non Turbo	VO-95 ^{X504} VO-25 ^{Z504}	VA-104		
4 cyl. 2.0L (F) FI Turbo	VO-106	VA-104		

Expo

4 cyl. 2.4L (G) FI	VO-106	VA-104		
--------------------	--------	--------	--	--

Galant

4 cyl. 2.4L (G) FI	VO-106	VA-104		
--------------------	--------	--------	--	--

Mighty Max Pickup

4 cyl. 2.4L (G) FI	VO-106	VA-99		
--------------------	--------	-------	--	--

Mirage

4 cyl. 1.5L (A) FI	VO-106	VA-387		
4 cyl. 1.8L (C) FI	VO-106	VA-387		

Montero

V6 3.0L (H) FI	VO-106	VA-128		
V6 3.5L (M) FI	VO-106	VA-128		

1994

3000GT

V6 3.0L (J) FI Non Turbo	VO-106	VA-99		
V6 3.0L (K) FI Turbo	VO-106	VA-99		

MORGAN

2007

Aero 8

V8 4.4L FI	VO-128			
------------	--------	--	--	--

2006

Aero 8

V8 4.4L FI	VO-128			
------------	--------	--	--	--

2005

Aero 8

V8 4.4L FI	VO-128			
------------	--------	--	--	--

2004

Aero 8

V8 4.4L FI	VO-74			
------------	-------	--	--	--

MOBILITY VENTURES

2017

MV-1

V6 3.7L	VO-88			
---------	-------	--	--	--

2016

MV-1

V6 3.7L	VO-88			
---------	-------	--	--	--

2015

MV-1

V6 3.7L	VO-88			
V8 4.6L	VO-88			

Se reporter à table de matière pour les notes en bas de page en français. Utilize el contenido para ver notas a pie.

NS - Non-Serviceable / Non réparable / No repairable LF - Life-Time Filter / Filtro para toda la vida / Filtre à vie

^{X504}Alternate ^{Z504}Primary



MOBILITY VENTURES (cont'd)

MOBILITY VENTURES (cont'd)				
2014				
MV-1				
V8 4.6L	VO-88			
NISSAN				
2019				
370Z				
V6 3.7L	VO-106	VA-332 ¹¹²		NS ⁴³⁷
Altima				
4 cyl. 2.0L Turbo	VO-106			NS ⁴³⁷
4 cyl. 2.5L	VO-106			NS ⁴³⁷
Armada				
V8 5.6L	VO-106		VCA-1044	NS ⁴³⁷
Frontier				
4 cyl. 2.5L	VO-106	VA-356	VCA-1041	NS ⁴³⁷
V6 4.0L	VO-106	VA-105	VCA-1041	NS ⁴³⁷
GT-R				
V6 3.8L Turbo	VO-106		VCA-1044	NS ⁴³⁷
Kicks				
4 cyl. 1.6L	VO-106			NS ⁴³⁷
Leaf				
Electric			VCA-1171	
Maxima				
V6 3.5L	VO-106	VA-86	VCA-1082	NS ⁴³⁷
Murano				
V6 3.5L	VO-106	VA-86	VCA-1082	NS ⁴³⁷
NV 200				
4 cyl. 2.0L	VO-106	VA-244	VCA-2043	NS ⁴³⁷
NV1500, NV2500HD, NV3500HD				
V6 4.0L	VO-106	VA-105		NS ⁴³⁷
V8 5.6L	VO-106			NS ⁴³⁷
Pathfinder				
V6 3.5L	VO-106	VA-86	VCA-1082	NS ⁴³⁷
Qashqai				
4 cyl. 2.0	VO-106	VA-438	VCA-1178	NS ⁴³⁷
Rogue				
4 cyl. 2.0 Hybrid	VO-106	VA-438	VCA-1178	NS ⁴³⁷
4 cyl. 2.5L	VO-106	VA-438	VCA-1178	NS ⁴³⁷
Rogue Sport				
4 cyl. 2.0	VO-106	VA-438	VCA-1178	NS ⁴³⁷
Sentra				
4 cyl. 1.6L Turbo	VO-106	VA-261	VCA-1171	NS ⁴³⁷
4 cyl. 1.8L	VO-106	VA-261	VCA-1171	NS ⁴³⁷
Titan				
V8 5.6L	VO-106	VA-470	VCA-1044	NS ⁴³⁷
Titan XD				
V8 5.0L Diesel Turbo			VCA-1044	
V8 5.6L	VO-106		VCA-1044	NS ⁴³⁷
Versa				
4 cyl. 1.6L	VO-106	VA-301		NS ⁴³⁷
Versa Note				
4 cyl. 1.6	VO-106	VA-301		NS ⁴³⁷

Se reporter à table de matière pour les notes en bas de page en français. Utilize el contenido para ver notas a pie.

NS - Non-Serviceable / Non réparable / No reparable LF - Life-Time Filter / Filtro para toda la vida / Filtre à vie

¹¹² Requires two (2). ⁴³⁷ Requires replacement of the complete fuel pump/fuel filter module.



NISSAN (cont'd)

2018

370Z

V6 3.7L	VO-106	VA-332 ¹¹²		NS ⁴³⁷
Altima				
4 cyl. 2.5L	VO-106	VA-312	VCA-1082	NS ⁴³⁷
V6 3.5L	VO-106	VA-86	VCA-1082	NS ⁴³⁷
Armada				
V8 5.6L	VO-106		VCA-1044	NS ⁴³⁷
Frontier				
4 cyl. 2.5L	VO-106	VA-356	VCA-1041	NS ⁴³⁷
V6 4.0L	VO-106	VA-105	VCA-1041	NS ⁴³⁷
GT-R				
V6 3.8L Turbo	VO-106		VCA-1044	NS ⁴³⁷
Kicks				
4 cyl. 1.6L	VO-106			NS ⁴³⁷
Leaf				
Electric			VCA-1171	
Maxima				
V6 3.5L	VO-106	VA-86	VCA-1082	NS ⁴³⁷
Micra (Canada)				
4 cyl. 1.6L	VO-106	VA-301	VCA-2043	NS ⁴³⁷
Murano				
V6 3.5L	VO-106	VA-86	VCA-1082	NS ⁴³⁷
NV 200				
4 cyl. 2.0L	VO-106	VA-244	VCA-2043	NS ⁴³⁷
NV1500, NV2500HD, NV3500HD				
V6 4.0L	VO-106	VA-105		NS ⁴³⁷
V8 5.6L	VO-106			NS ⁴³⁷
Pathfinder				
V6 3.5L	VO-106	VA-86	VCA-1082	NS ⁴³⁷
Qashqai				
4 cyl. 2.0	VO-106	VA-438	VCA-1178	NS ⁴³⁷
Rogue				
4 cyl. 2.0 Hybrid	VO-106	VA-438	VCA-1178	NS ⁴³⁷
4 cyl. 2.5L	VO-106	VA-438	VCA-1178	NS ⁴³⁷
Rogue Sport				
4 cyl. 2.0	VO-106	VA-438	VCA-1178	NS ⁴³⁷
Sentra				
4 cyl 1.6L Turbo	VO-106	VA-261	VCA-1171	NS ⁴³⁷
4 cyl 1.8L	VO-106	VA-261	VCA-1171	NS ⁴³⁷
Titan				
V8 5.6L	VO-106	VA-470	VCA-1044	NS ⁴³⁷
Titan XD				
V8 5.0L Diesel Turbo			VCA-1044	
V8 5.6L	VO-106		VCA-1044	NS ⁴³⁷
Versa				
4 cyl 1.6L	VO-106	VA-301	VCA-1052 ^{X892} VCA-2043 ^{Z892}	NS ⁴³⁷
Versa Note				
4 cyl. 1.6	VO-106	VA-301	VCA-2043	NS ⁴³⁷
2017				
370Z				
V6 3.7L	VO-106	VA-332 ¹¹²		NS ⁴³⁷

Se reporter à table de matière pour les notes en bas de page en français. Utilize el contenido para ver notas a pie.

NS - Non-Serviceable / Non réparable / No repairable LF - Life-Time Filter / Filtro para toda la vida / Filtre à vie

¹¹² Requires two (2). ⁴³⁷ Requires replacement of the complete fuel pump/fuel filter module. ^{X892}filter with plastic side support ^{Z892}filter without plastic side support



NISSAN (cont'd)

2017				
Altima				
4 cyl. 2.5L	VO-106	VA-312	VCA-1082	NS ⁴³⁷
V6 3.5L	VO-106	VA-86	VCA-1082	NS ⁴³⁷
Armada				
V8 5.6L	VO-106		VCA-1044	NS ⁴³⁷
Frontier				
4 cyl. 2.5L	VO-106	VA-356	VCA-1041	NS ⁴³⁷
V6 4.0L	VO-106	VA-105	VCA-1041	NS ⁴³⁷
GT-R				
V6 3.8L Turbo	VO-106		VCA-1044	NS ⁴³⁷
Juke				
4 cyl. 1.6L Turbo	VO-106	VA-261	VCA-1171	NS ⁴³⁷
Kicks				
4 cyl. 1.6L	VO-106			NS ⁴³⁷
Leaf				
Electric			VCA-1171	
Maxima				
V6 3.5L	VO-106	VA-86	VCA-1082	NS ⁴³⁷
Micra (Canada)				
4 cyl. 1.6L	VO-106	VA-301	VCA-2043	NS ⁴³⁷
Murano				
V6 3.5L	VO-106	VA-86	VCA-1082	NS ⁴³⁷
NV 200				
4 cyl. 2.0L	VO-106	VA-244		NS ⁴³⁷
NV1500, NV2500HD, NV3500HD				
V6 4.0L	VO-106	VA-105	VCA-1041	NS ⁴³⁷
V8 5.6L	VO-106	VA-105 ⁸⁸¹	VCA-1041	NS ⁴³⁷
Pathfinder				
V6 3.5L	VO-106	VA-86	VCA-1082	NS ⁴³⁷
Qashqai				
4 cyl. 2.0	VO-106	VA-438	VCA-1178	NS ⁴³⁷
Quest				
V6 3.5L	VO-106	VA-86	VCA-1038	NS ⁴³⁷
Rogue				
4 cyl. 2.0 Hybrid	VO-106	VA-438	VCA-1178	NS ⁴³⁷
4 cyl. 2.5L	VO-106	VA-438	VCA-1178	NS ⁴³⁷
Rogue Sport				
4 cyl. 2.0	VO-106	VA-438	VCA-1178	NS ⁴³⁷
Sentra				
4 cyl 1.6L Turbo	VO-106	VA-261	VCA-1171	NS ⁴³⁷
4 cyl 1.8L	VO-106	VA-261	VCA-1171	NS ⁴³⁷
Titan				
V8 5.6L	VO-106	VA-470	VCA-1044	NS ⁴³⁷
Titan XD				
V8 5.0L Diesel Turbo			VCA-1044	
V8 5.6L	VO-106		VCA-1044	NS ⁴³⁷
Versa				
4 cyl 1.6L	VO-106	VA-301	VCA-1052 ^{X892} VCA-2043 ^{Z892}	NS ⁴³⁷
Versa Note				
4 cyl. 1.6	VO-106	VA-301	VCA-2043	NS ⁴³⁷

Se reporter à table de matière pour les notes en bas de page en français. Utilize el contenido para ver notas a pie.

NS - Non-Serviceable / Non réparable / No reparable LF - Life-Time Filter / Filtro para toda la vida / Filtre à vie

⁴³⁷ Requires replacement of the complete fuel pump/fuel filter module. ⁸⁸¹ Before 1/17/2017 ^{X892} filter with plastic side support ^{Z892} filter without plastic side support



NISSAN (cont'd)

2016

370Z

V6 3.7L	VO-106	VA-332 ¹¹²		NS ⁴³⁷
---------	--------	-----------------------	--	-------------------

Altima

4 cyl. 2.5L	VO-106	VA-312	VCA-1082	NS ⁴³⁷
-------------	--------	--------	----------	-------------------

V6 3.5L	VO-106	VA-86	VCA-1082	NS ⁴³⁷
---------	--------	-------	----------	-------------------

Frontier

4 cyl. 2.5L	VO-106	VA-356	VCA-1041	NS ⁴³⁷
-------------	--------	--------	----------	-------------------

V6 4.0L	VO-106	VA-105	VCA-1041	NS ⁴³⁷
---------	--------	--------	----------	-------------------

GT-R

V6 3.8L Turbo	VO-106		VCA-1044	NS ⁴³⁷
---------------	--------	--	----------	-------------------

Juke

4 cyl. 1.6L Turbo	VO-106	VA-261	VCA-1171	NS ⁴³⁷
-------------------	--------	--------	----------	-------------------

Leaf

Electric			VCA-1171	
----------	--	--	----------	--

Maxima

V6 3.5L	VO-106	VA-86	VCA-1082	NS ⁴³⁷
---------	--------	-------	----------	-------------------

Micra (Canada)

4 cyl. 1.6L	VO-106	VA-301	VCA-2043	NS ⁴³⁷
-------------	--------	--------	----------	-------------------

Murano

4 cyl. 2.5L Hybrid	VO-106		VCA-1082	NS ⁴³⁷
--------------------	--------	--	----------	-------------------

V6 3.5L	VO-106	VA-86	VCA-1082	NS ⁴³⁷
---------	--------	-------	----------	-------------------

NV 200

4 cyl. 2.0L	VO-106	VA-244		NS ⁴³⁷
-------------	--------	--------	--	-------------------

NV1500, NV2500HD, NV3500HD

V6 4.0L	VO-106	VA-105	VCA-1041	NS ⁴³⁷
---------	--------	--------	----------	-------------------

V8 5.6L	VO-106	VA-105	VCA-1041	NS ⁴³⁷
---------	--------	--------	----------	-------------------

Pathfinder

V6 3.5L	VO-106	VA-86	VCA-1082	NS ⁴³⁷
---------	--------	-------	----------	-------------------

Quest

V6 3.5L	VO-106	VA-86	VCA-1038	NS ⁴³⁷
---------	--------	-------	----------	-------------------

Rogue

4 cyl 2.5L	VO-106	VA-438	VCA-1178	NS ⁴³⁷
------------	--------	--------	----------	-------------------

Sentra

4 cyl 1.8L	VO-106	VA-261	VCA-1171	NS ⁴³⁷
------------	--------	--------	----------	-------------------

Titan XD

V8 5.0L Diesel Turbo			VCA-1044	
----------------------	--	--	----------	--

V8 5.6L	VO-106		VCA-1044	NS ⁴³⁷
---------	--------	--	----------	-------------------

Versa

4 cyl 1.6L	VO-106	VA-301	VCA-1052 ^{X892} VCA-2043 ^{Z892}	NS ⁴³⁷
------------	--------	--------	--	-------------------

Versa Note

4 cyl. 1.6	VO-106	VA-301	VCA-2043	NS ⁴³⁷
------------	--------	--------	----------	-------------------

2015

370Z

V6 3.7L	VO-106	VA-332 ¹¹²		NS ⁴³⁷
---------	--------	-----------------------	--	-------------------

Altima

4 cyl. 2.5L FI	VO-106	VA-312	VCA-1082	NS ⁴³⁷
----------------	--------	--------	----------	-------------------

V6 3.5L	VO-106	VA-86	VCA-1082	NS ⁴³⁷
---------	--------	-------	----------	-------------------

Armada

V8 5.6L	VO-106	VA-105	VCA-1048	NS ⁴³⁷
---------	--------	--------	----------	-------------------

Frontier

4 cyl. 2.5L	VO-106	VA-356	VCA-1041	NS ⁴³⁷
-------------	--------	--------	----------	-------------------

Se reporter à table de matière pour les notes en bas de page en français. Utilize el contenido para ver notas a pie.

NS - Non-Serviceable / Non réparable / No repairable LF - Life-Time Filter / Filtro para toda la vida / Filtre à vie

¹¹² Requires two (2). ⁴³⁷ Requires replacement of the complete fuel pump/fuel filter module. ^{X892}filter with plastic side support ^{Z892}filter without plastic side support



NISSAN (cont'd)

	Oil	Air	Cabin*	Fuel
2015				
Frontier				
V6 4.0L	VO-106	VA-105	VCA-1041	NS ⁴³⁷
GT-R				
V6 3.8L Turbo	VO-106		VCA-1044	NS ⁴³⁷
Juke				
4 cyl. 1.6L Turbo	VO-106	VA-261	VCA-1171	NS ⁴³⁷
Leaf				
Electric			VCA-1171	
Micra (Canada)				
4 cyl. 1.6L	VO-106	VA-301	VCA-2043	NS ⁴³⁷
Murano				
V6 3.5L	VO-106	VA-86	VCA-1082	NS ⁴³⁷
NV 200				
4 cyl. 2.0L	VO-106	VA-244		NS ⁴³⁷
NV1500, NV2500HD, NV3500HD				
V6 4.0L	VO-106	VA-105	VCA-1041	NS ⁴³⁷
V8 5.6L	VO-106	VA-105	VCA-1041	NS ⁴³⁷
Pathfinder				
4 cyl. 2.5L Hybrid	VO-106		VCA-1082	NS ⁴³⁷
V6 3.5L	VO-106	VA-86	VCA-1082	NS ⁴³⁷
Quest				
V6 3.5L	VO-106	VA-86	VCA-1038	NS ⁴³⁷
Rogue				
4 cyl. 2.5L	VO-106	VA-438	VCA-1178	NS ⁴³⁷
Rogue Select				
4 cyl. 2.5	VO-106	VA-261	VCA-1034	NS ⁴³⁷
Sentra				
4 cyl. 1.8L	VO-106	VA-261	VCA-1171	NS ⁴³⁷
Titan				
V8 5.6L	VO-106	VA-105	VCA-1048	NS ⁴³⁷
Versa				
4 cyl. 1.6L	VO-106	VA-301	VCA-1052 ^{X892} VCA-2043 ^{Z892}	NS ⁴³⁷
Versa Note				
4 cyl. 1.6	VO-106	VA-301	VCA-2043	NS ⁴³⁷
Xterra				
V6 4.0L	VO-106	VA-105	VCA-1041	NS ⁴³⁷
2014				
370Z				
V6 3.7L	VO-106	VA-332 ¹¹²		NS ⁴³⁷
Altima				
4 cyl. 2.5L	VO-106	VA-312	VCA-1082	NS ⁴³⁷
V6 3.5L	VO-106	VA-86	VCA-1082	NS ⁴³⁷
Armada				
V8 5.6L	VO-106	VA-105	VCA-1048	NS ⁴³⁷
Cube				
4 cyl. 1.8L FI	VO-106	VA-244	VCA-1171	NS ⁴³⁷
Frontier				
4 cyl. 2.5L	VO-106	VA-356	VCA-1041	NS ⁴³⁷
V6 4.0L	VO-106	VA-105	VCA-1041	NS ⁴³⁷
GT-R				
V6 3.8L Turbo	VO-106		VCA-1044	NS ⁴³⁷

Se reporter à table de matière pour les notes en bas de page en français. Utilize el contenido para ver notas a pie.

NS - Non-Serviceable / Non réparable / No reparable LF - Life-Time Filter / Filtro para toda la vida / Filtre à vie

¹¹² Requires two (2). ⁴³⁷ Requires replacement of the complete fuel pump/fuel filter module. ^{X892} Filter with plastic side support ^{Z892} filter without plastic side support



NISSAN (cont'd)

2014

Juke

4 cyl. 1.6L Turbo	VO-106	VA-261	VCA-1171	NS ⁴³⁷
-------------------	--------	--------	----------	-------------------

Leaf

Electric			VCA-1171	
----------	--	--	----------	--

Maxima

V6 3.5L	VO-106	VA-86	VCA-1038	NS ⁴³⁷
---------	--------	-------	----------	-------------------

Murano

V6 3.5L	VO-106	VA-86	VCA-1038	NS ⁴³⁷
---------	--------	-------	----------	-------------------

NV 200

4 cyl. 2.0L	VO-106	VA-244		NS ⁴³⁷
-------------	--------	--------	--	-------------------

NV1500, NV2500HD, NV3500HD

V6 4.0L	VO-106	VA-105	VCA-1041	NS ⁴³⁷
---------	--------	--------	----------	-------------------

V8 5.6L	VO-106	VA-105	VCA-1041	NS ⁴³⁷
---------	--------	--------	----------	-------------------

Pathfinder

4 cyl. 2.5L Hybrid	VO-106		VCA-1082	NS ⁴³⁷
--------------------	--------	--	----------	-------------------

V6 3.5L	VO-106	VA-86	VCA-1082	NS ⁴³⁷
---------	--------	-------	----------	-------------------

Quest

V6 3.5L	VO-106	VA-86	VCA-1038	NS ⁴³⁷
---------	--------	-------	----------	-------------------

Rogue

4 cyl 2.5L	VO-106	VA-438	VCA-1178	NS ⁴³⁷
------------	--------	--------	----------	-------------------

Rogue Select

4 cyl. 2.5	VO-106	VA-261	VCA-1034	NS ⁴³⁷
------------	--------	--------	----------	-------------------

Sentra

4 cyl 1.8L	VO-106	VA-261	VCA-1171	NS ⁴³⁷
------------	--------	--------	----------	-------------------

Titan

V8 5.6L	VO-106	VA-105	VCA-1048	NS ⁴³⁷
---------	--------	--------	----------	-------------------

Versa

4 cyl 1.6L	VO-106	VA-301	VCA-1052 ^{X892} VCA-2043 ^{Z892}	NS ⁴³⁷
------------	--------	--------	--	-------------------

Versa Note

4 cyl. 1.6	VO-106	VA-301	VCA-2043	NS ⁴³⁷
------------	--------	--------	----------	-------------------

Xterra

V6 4.0L	VO-106	VA-105	VCA-1041	NS ⁴³⁷
---------	--------	--------	----------	-------------------

2013

370Z

V6 3.7L	VO-106	VA-332 ¹¹²		NS ⁴³⁷
---------	--------	-----------------------	--	-------------------

Altima

4 cyl. 2.5L	VO-106	VA-312 ^{X786} VA-233 ^{Z786}	VCA-1082	NS ⁴³⁷
-------------	--------	--	----------	-------------------

V6 3.5L	VO-106	VA-86	VCA-1082	NS ⁴³⁷
---------	--------	-------	----------	-------------------

Armada

V8 5.6L	VO-106	VA-105	VCA-1048	NS ⁴³⁷
---------	--------	--------	----------	-------------------

Cube

4 cyl 1.8L FI	VO-106	VA-244	VCA-1171	NS ⁴³⁷
---------------	--------	--------	----------	-------------------

Frontier

4 cyl. 2.5L	VO-106	VA-356	VCA-1041	NS ⁴³⁷
-------------	--------	--------	----------	-------------------

V6 4.0L	VO-106	VA-105	VCA-1041	NS ⁴³⁷
---------	--------	--------	----------	-------------------

GT-R

V6 3.8L Turbo	VO-106		VCA-1044	NS ⁴³⁷
---------------	--------	--	----------	-------------------

Juke

4 cyl. 1.6L Turbo	VO-106	VA-261	VCA-1171	NS ⁴³⁷
-------------------	--------	--------	----------	-------------------

Se reporter à table de matière pour les notes en bas de page en français. Utilize el contenido para ver notas a pie.

NS - Non-Serviceable / Non réparable / No reparable LF - Life-Time Filter / Filtro para toda la vida / Filtre à vie

¹¹² Requires two (2). ⁴³⁷ Requires replacement of the complete fuel pump/fuel filter module. ^{X786}Sedan ^{X892}filter with plastic side support ^{Z786}Coupe ^{Z892}filter without plastic side support



NISSAN (cont'd)

	Oil	Air	Cabin*	Fuel
2013				
Leaf				
Electric			VCA-1171	
Maxima				
V6 3.5L	VO-106	VA-86	VCA-1038	NS ⁴³⁷
Murano				
V6 3.5L	VO-106	VA-86	VCA-1038	NS ⁴³⁷
NV 200				
4 cyl. 2.0L	VO-106	VA-244		NS ⁴³⁷
NV1500, NV2500HD, NV3500HD				
V6 4.0L	VO-106	VA-105	VCA-1041	NS ⁴³⁷
V8 5.6L	VO-106	VA-105	VCA-1041	NS ⁴³⁷
Pathfinder				
V6 3.5L	VO-106	VA-86	VCA-1082	NS ⁴³⁷
Quest				
V6 3.5L	VO-106	VA-86	VCA-1038	NS ⁴³⁷
Rogue				
4 cyl. 2.5L	VO-106	VA-261	VCA-1034	NS ⁴³⁷
Sentra				
4 cyl. 1.8L	VO-106	VA-261	VCA-1171	NS ⁴³⁷
Titan				
V8 5.6L	VO-106	VA-105	VCA-1048	NS ⁴³⁷
Versa				
4 cyl. 1.6L	VO-106	VA-301	VCA-1052	NS ⁴³⁷
Xterra				
V6 4.0L	VO-106	VA-105	VCA-1041	NS ⁴³⁷
2012				
370Z				
V6 3.7L	VO-106	VA-332 ¹¹²		NS ⁴³⁷
Altima				
4 cyl. 2.5L	VO-106	VA-233	VCA-1038	NS ⁴³⁷
V6 3.5L	VO-106	VA-86	VCA-1038	NS ⁴³⁷
Armada				
V8 5.6L	VO-106	VA-105	VCA-1048	NS ⁴³⁷
Cube				
4 cyl. 1.8L FI	VO-106	VA-244	VCA-1171	NS ⁴³⁷
Frontier				
4 cyl. 2.5L FI	VO-106	VA-356	VCA-1041	NS ⁴³⁷
V6 4.0L	VO-106	VA-105	VCA-1041	NS ⁴³⁷
GT-R				
V6 3.8L Turbo	VO-106		VCA-1044	NS ⁴³⁷
Juke				
4 cyl. 1.6L Turbo	VO-106	VA-261	VCA-1171	NS ⁴³⁷
Leaf				
Electric			VCA-1171	
Maxima				
V6 3.5L	VO-106	VA-86	VCA-1038	NS ⁴³⁷
Murano				
V6 3.5L	VO-106	VA-86	VCA-1038	NS ⁴³⁷
NV1500, NV2500HD, NV3500HD				
V6 4.0L	VO-106	VA-105	VCA-1041	NS ⁴³⁷
V8 5.6L	VO-106	VA-105	VCA-1041	NS ⁴³⁷

Se reporter à table de matière pour les notes en bas de page en français. Utilize el contenido para ver notas a pie.

NS - Non-Serviceable / Non réparable / No repairable LF - Life-Time Filter / Filtro para toda la vida / Filtre à vie

¹¹² Requires two (2). ⁴³⁷ Requires replacement of the complete fuel pump/fuel filter module.



NISSAN (cont'd)

2012

Pathfinder

V6 4.0L	VO-106	VA-105	VCA-1041	NS ⁴³⁷
V8 5.6L	VO-106	VA-105	VCA-1041	NS ⁴³⁷

Quest

V6 3.5L	VO-106	VA-86	VCA-1038	NS ⁴³⁷
---------	--------	-------	----------	-------------------

Rogue

4 cyl 2.5L	VO-106	VA-261	VCA-1034	NS ⁴³⁷
------------	--------	--------	----------	-------------------

Sentra

4 cyl 2.0L	VO-106	VA-238	VCA-1034	NS ⁴³⁷
4 cyl 2.5L	VO-106	VA-261	VCA-1034	NS ⁴³⁷

Titan

V8 5.6L	VO-106	VA-105	VCA-1048	NS ⁴³⁷
---------	--------	--------	----------	-------------------

Versa

4 cyl 1.6L	VO-106	VA-301	VCA-1052	NS ⁴³⁷
4 cyl 1.8L	VO-106	VA-244	VCA-1052	NS ⁴³⁷

Xterra

V6 4.0L	VO-106	VA-105	VCA-1041	NS ⁴³⁷
---------	--------	--------	----------	-------------------

2011

370Z

V6 3.7L	VO-106	VA-332 ¹¹²		NS ⁴³⁷
---------	--------	-----------------------	--	-------------------

Altima

4 cyl. 2.5L	VO-106	VA-233	VCA-1038	NS ⁴³⁷
4 cyl. 2.5L Hybrid	VO-106	VA-233	VCA-1038	NS ⁴³⁷
V6 3.5L	VO-106	VA-86	VCA-1038	NS ⁴³⁷

Armada

V8 5.6L	VO-106	VA-105	VCA-1048	NS ⁴³⁷
---------	--------	--------	----------	-------------------

Cube

4 cyl 1.8L FI	VO-106	VA-244	VCA-1171	NS ⁴³⁷
---------------	--------	--------	----------	-------------------

Frontier

4 cyl. 2.5L	VO-106	VA-356	VCA-1041	NS ⁴³⁷
V6 4.0L	VO-106	VA-105	VCA-1041	NS ⁴³⁷

GT-R

V6 3.8L Turbo	VO-106		VCA-1044	NS ⁴³⁷
---------------	--------	--	----------	-------------------

Juke

4 cyl. 1.6L Turbo	VO-106	VA-261	VCA-1171	NS ⁴³⁷
-------------------	--------	--------	----------	-------------------

Leaf

Electric			VCA-1171	
----------	--	--	----------	--

Maxima

V6 3.5L	VO-106	VA-86	VCA-1038	NS ⁴³⁷
---------	--------	-------	----------	-------------------

Murano

V6 3.5L	VO-106	VA-86	VCA-1038	NS ⁴³⁷
---------	--------	-------	----------	-------------------

Pathfinder

V6 4.0L	VO-106	VA-105	VCA-1041	NS ⁴³⁷
V8 5.6L	VO-106	VA-105	VCA-1041	NS ⁴³⁷

Quest

V6 3.5L	VO-106	VA-86	VCA-1038	NS ⁴³⁷
---------	--------	-------	----------	-------------------

Rogue

4 cyl 2.5L	VO-106	VA-261	VCA-1034	NS ⁴³⁷
------------	--------	--------	----------	-------------------

Sentra

4 cyl 2.0L	VO-106	VA-238	VCA-1034	NS ⁴³⁷
4 cyl 2.5L	VO-106	VA-261	VCA-1034	NS ⁴³⁷

Se reporter à table de matière pour les notes en bas de page en français. Utilize el contenido para ver notas a pie.

NS - Non-Serviceable / Non réparable / No repairable LF - Life-Time Filter / Filtro para toda la vida / Filtre à vie

¹¹² Requires two (2). ⁴³⁷ Requires replacement of the complete fuel pump/fuel filter module.



NISSAN (cont'd)

	Oil	Air	Cabin*	Fuel
2011				
Titan				
V8 5.6L	VO-106	VA-105	VCA-1048	NS ⁴³⁷
Versa				
4 cyl 1.6L	VO-106	VA-244	VCA-1052	NS ⁴³⁷
4 cyl 1.8L	VO-106	VA-244	VCA-1052	NS ⁴³⁷
Xterra				
V6 4.0L	VO-106	VA-105	VCA-1041	NS ⁴³⁷
2010				
370Z				
V6 3.7L	VO-106	VA-332 ¹¹²		NS ⁴³⁷
Altima				
4 cyl 2.5L	VO-106	VA-233	VCA-1038	NS ⁴³⁷
4 cyl 2.5L Hybrid	VO-106	VA-233	VCA-1038	NS ⁴³⁷
V6 3.5L	VO-106	VA-86	VCA-1038	NS ⁴³⁷
Armada				
V8 5.6L FI	VO-106	VA-105	VCA-1048	NS ⁴³⁷
Cube				
4 cyl 1.8L FI	VO-106	VA-244	VCA-1171	NS ⁴³⁷
Frontier				
4 cyl 2.5L	VO-106	VA-356	VCA-1041	NS ⁴³⁷
V6 4.0L	VO-106	VA-105	VCA-1041	NS ⁴³⁷
GT-R				
V6 3.8L Turbo	VO-106		VCA-1044	NS ⁴³⁷
Maxima				
V6 3.5L	VO-106	VA-86	VCA-1038	NS ⁴³⁷
Murano				
V6 3.5L	VO-106	VA-86	VCA-1038	NS ⁴³⁷
Pathfinder				
V6 4.0L	VO-106	VA-105	VCA-1041	NS ⁴³⁷
V8 5.6L	VO-106	VA-105	VCA-1041	NS ⁴³⁷
Rogue				
4 cyl 2.5L	VO-106	VA-261	VCA-1034	NS ⁴³⁷
Sentra				
4 cyl 2.0L	VO-106	VA-238	VCA-1034	NS ⁴³⁷
4 cyl 2.5L	VO-106	VA-261	VCA-1034	NS ⁴³⁷
Titan				
V8 5.6L	VO-106	VA-105	VCA-1048	NS ⁴³⁷
Versa				
4 cyl 1.6L	VO-106	VA-244	VCA-1052	NS ⁴³⁷
4 cyl 1.8L	VO-106	VA-244	VCA-1052	NS ⁴³⁷
Xterra				
V6 4.0L	VO-106	VA-105	VCA-1041	NS ⁴³⁷
2009				
350Z				
V6 3.5L FI	VO-106	VA-332 ¹¹²		NS ⁴³⁷
370Z				
V6 3.7L	VO-106	VA-332 ¹¹²		NS ⁴³⁷
Altima				
4 cyl 2.5L FI	VO-106	VA-233	VCA-1038	NS ⁴³⁷
4 cyl 2.5L FI (Hybrid)	VO-106	VA-233	VCA-1038	NS ⁴³⁷
V6 3.5L FI	VO-106	VA-86	VCA-1038	NS ⁴³⁷

Se reporter à table de matière pour les notes en bas de page en français. Utilize el contenido para ver notas a pie.

NS - Non-Serviceable / Non réparable / No repairable LF - Life-Time Filter / Filtro para toda la vida / Filtre à vie

¹¹² Requires two (2). ⁴³⁷ Requires replacement of the complete fuel pump/fuel filter module.



NISSAN (cont'd)

2009

Armada

V8 5.6L FI	VO-106	VA-105	VCA-1048	NS ⁴³⁷
------------	--------	--------	----------	-------------------

Cube

4 cyl. 1.8L FI	VO-106	VA-244	VCA-1171	NS ⁴³⁷
----------------	--------	--------	----------	-------------------

Frontier

4 cyl. 2.5L FI	VO-106	VA-356	VCA-1041	NS ⁴³⁷
----------------	--------	--------	----------	-------------------

V6 4.0L FI	VO-106	VA-105	VCA-1041	NS ⁴³⁷
------------	--------	--------	----------	-------------------

GT-R

V6 3.8L Turbo	VO-106		VCA-1044	NS ⁴³⁷
---------------	--------	--	----------	-------------------

Maxima

V6 3.5L FI	VO-106	VA-86	VCA-1038	NS ⁴³⁷
------------	--------	-------	----------	-------------------

Murano

V6 3.5L FI	VO-106	VA-86	VCA-1038	NS ⁴³⁷
------------	--------	-------	----------	-------------------

Pathfinder

V6 4.0L FI	VO-106	VA-105	VCA-1041	NS ⁴³⁷
------------	--------	--------	----------	-------------------

V8 5.6L FI	VO-106	VA-105	VCA-1041	NS ⁴³⁷
------------	--------	--------	----------	-------------------

Quest

V6 3.5L FI	VO-106	VA-86	VCA-1159 ¹¹²	NS ⁴³⁷
------------	--------	-------	-------------------------	-------------------

Rogue

4 cyl 2.5L	VO-106	VA-261	VCA-1034	NS ⁴³⁷
------------	--------	--------	----------	-------------------

Sentra

4 cyl 2.0L FI	VO-106	VA-238	VCA-1034	NS ⁴³⁷
---------------	--------	--------	----------	-------------------

4 cyl 2.5L FI	VO-106	VA-261	VCA-1034	NS ⁴³⁷
---------------	--------	--------	----------	-------------------

Titan

V8 5.6L FI	VO-106	VA-105	VCA-1048	NS ⁴³⁷
------------	--------	--------	----------	-------------------

Versa

4 cyl 1.6L FI	VO-106	VA-244	VCA-1052	NS ⁴³⁷
---------------	--------	--------	----------	-------------------

4 cyl 1.8L FI	VO-106	VA-244	VCA-1052	NS ⁴³⁷
---------------	--------	--------	----------	-------------------

Xterra

V6 4.0L FI	VO-106	VA-105	VCA-1041	NS ⁴³⁷
------------	--------	--------	----------	-------------------

2008

350Z

V6 3.5L FI	VO-106	VA-332 ¹¹²		NS ⁴³⁷
------------	--------	-----------------------	--	-------------------

Altima

4 cyl 2.5L FI (Hybrid)	VO-106	VA-233	VCA-1038	NS ⁴³⁷
------------------------	--------	--------	----------	-------------------

4 cyl. 2.5L FI	VO-106	VA-233	VCA-1038	NS ⁴³⁷
----------------	--------	--------	----------	-------------------

V6 3.5L FI	VO-106	VA-86	VCA-1038	NS ⁴³⁷
------------	--------	-------	----------	-------------------

Armada

V8 5.6L FI	VO-106	VA-105	VCA-1048	NS ⁴³⁷
------------	--------	--------	----------	-------------------

Frontier

4 cyl. 2.5L FI	VO-106	VA-356	VCA-1041	NS ⁴³⁷
----------------	--------	--------	----------	-------------------

V6 4.0L FI	VO-106	VA-105	VCA-1041	NS ⁴³⁷
------------	--------	--------	----------	-------------------

Maxima

V6 3.5L FI	VO-106	VA-86	VCA-1068	NS ⁴³⁷
------------	--------	-------	----------	-------------------

Pathfinder

V6 4.0L FI	VO-106	VA-105	VCA-1041	NS ⁴³⁷
------------	--------	--------	----------	-------------------

V8 5.6L FI	VO-106	VA-105	VCA-1041	NS ⁴³⁷
------------	--------	--------	----------	-------------------

Quest

V6 3.5L FI	VO-106	VA-86	VCA-1159 ¹¹²	NS ⁴³⁷
------------	--------	-------	-------------------------	-------------------

Rogue

4 cyl 2.5L	VO-106	VA-261	VCA-1034	NS ⁴³⁷
------------	--------	--------	----------	-------------------

Se reporter à table de matière pour les notes en bas de page en français. Utilize el contenido para ver notas a pie.

NS - Non-Serviceable / Non réparable / No repairable LF - Life-Time Filter / Filtro para toda la vida / Filtre à vie

¹¹² Requires two (2). ⁴³⁷ Requires replacement of the complete fuel pump/fuel filter module.



NISSAN (cont'd)

	Oil	Air	Cabin*	Fuel
2008				
Sentra				
4 cyl 2.0L FI	VO-106	VA-238	VCA-1034	NS ⁴³⁷
4 cyl 2.5L FI	VO-106	VA-261	VCA-1034	NS ⁴³⁷
Titan				
V8 5.6L FI	VO-106	VA-105	VCA-1048	NS ⁴³⁷
Versa				
4 cyl 1.8L FI	VO-106	VA-244	VCA-1052	NS ⁴³⁷
Xterra				
V6 4.0L FI	VO-106	VA-105	VCA-1041	NS ⁴³⁷
2007				
350Z				
V6 3.5L FI	VO-106	VA-332 ¹¹²		NS ⁴³⁷
Altima				
4 cyl 2.5L FI (Hybrid)	VO-106	VA-233	VCA-1038	NS ⁴³⁷
4 cyl 2.5L FI	VO-106	VA-233	VCA-1038	NS ⁴³⁷
V6 3.5L FI	VO-106	VA-86	VCA-1038	NS ⁴³⁷
Armada				
V8 5.6L FI	VO-106	VA-105	VCA-1048	NS ⁴³⁷
Frontier				
4 cyl 2.5L FI	VO-106	VA-356	VCA-1041	NS ⁴³⁷
V6 4.0L FI	VO-106	VA-105	VCA-1041	NS ⁴³⁷
Maxima				
V6 3.5L FI	VO-106	VA-86	VCA-1068	NS ⁴³⁷
Murano				
V6 3.5L FI	VO-106	VA-86	VCA-1068	NS ⁴³⁷
Pathfinder				
V6 4.0L FI	VO-106	VA-105	VCA-1041	NS ⁴³⁷
Quest				
V6 3.5L FI	VO-106	VA-86	VCA-1159 ¹¹²	NS ⁴³⁷
Sentra				
4 cyl 2.0L FI	VO-106	VA-238	VCA-1034	NS ⁴³⁷
4 cyl 2.5L FI	VO-106	VA-261	VCA-1034	NS ⁴³⁷
Titan				
V8 5.6L FI	VO-106	VA-105	VCA-1048	NS ⁴³⁷
Versa				
4 cyl 1.8L FI	VO-106	VA-244	VCA-1052	NS ⁴³⁷
Xterra				
V6 4.0L FI	VO-106	VA-105	VCA-1041	NS ⁴³⁷
2006				
350Z				
V6 3.5L FI	VO-106	VA-86		NS ⁴³⁷
Altima				
4 cyl 2.5L FI	VO-106	VA-86	VCA-1068	NS ⁴³⁷
V6 3.5L FI	VO-106	VA-86	VCA-1068	NS ⁴³⁷
Armada				
V8 5.6L FI	VO-106	VA-105	VCA-1048	NS ⁴³⁷
Frontier				
4 cyl 2.5L FI	VO-106	VA-356	VCA-1041	NS ⁴³⁷
V6 4.0L FI	VO-106	VA-105	VCA-1041	NS ⁴³⁷
Maxima				
V6 3.5L FI	VO-106	VA-86	VCA-1068	NS ⁴³⁷

Se reporter à table de matière pour les notes en bas de page en français. Utilize el contenido para ver notas a pie.

NS - Non-Serviceable / Non réparable / No repairable LF - Life-Time Filter / Filtro para toda la vida / Filtre à vie

¹¹² Requires two (2). ⁴³⁷ Requires replacement of the complete fuel pump/fuel filter module.



NISSAN (cont'd)

2006

Murano

V6 3.5L FI	VO-106	VA-86	VCA-1068	NS ⁴³⁷
------------	--------	-------	----------	-------------------

Pathfinder

V6 4.0L FI	VO-106	VA-105	VCA-1041	NS ⁴³⁷
------------	--------	--------	----------	-------------------

Quest

V6 3.5L FI	VO-106	VA-86	VCA-1159 ¹¹²	NS ⁴³⁷
------------	--------	-------	-------------------------	-------------------

Sentra

4 cyl. 1.8L FI	VO-106	VA-86	VCA-1068	NS ⁴³⁷
----------------	--------	-------	----------	-------------------

4 cyl. 2.5L FI	VO-106	VA-86	VCA-1068	NS ⁴³⁷
----------------	--------	-------	----------	-------------------

Titan

V8 5.6L FI	VO-106	VA-105	VCA-1048	NS ⁴³⁷
------------	--------	--------	----------	-------------------

Xtrail (Canada)

4 cyl. 2.5L FI	VO-106	VA-86	VCA-1068	NS ⁴³⁷
----------------	--------	-------	----------	-------------------

Xterra

V6 4.0L FI	VO-106	VA-105	VCA-1041	NS ⁴³⁷
------------	--------	--------	----------	-------------------

2005

350Z

V6 3.5L FI	VO-106	VA-86		NS ⁴³⁷
------------	--------	-------	--	-------------------

Altima

4 cyl. 2.5L FI	VO-106	VA-86	VCA-1068	NS ⁴³⁷
----------------	--------	-------	----------	-------------------

V6 3.5L FI	VO-106	VA-86	VCA-1068	NS ⁴³⁷
------------	--------	-------	----------	-------------------

Armada

V8 5.6L FI	VO-106	VA-105	VCA-1048	NS ⁴³⁷
------------	--------	--------	----------	-------------------

Frontier

4 cyl. 2.5L FI	VO-106	VA-356	VCA-1041	NS ⁴³⁷
----------------	--------	--------	----------	-------------------

V6 4.0L FI	VO-106	VA-105	VCA-1041	NS ⁴³⁷
------------	--------	--------	----------	-------------------

Maxima

V6 3.5L FI	VO-106	VA-86	VCA-1068	NS ⁴³⁷
------------	--------	-------	----------	-------------------

Murano

V6 3.5L FI	VO-106	VA-86	VCA-1068	NS ⁴³⁷
------------	--------	-------	----------	-------------------

Pathfinder

V6 4.0L FI	VO-106	VA-105	VCA-1041	NS ⁴³⁷
------------	--------	--------	----------	-------------------

Quest

V6 3.5L FI	VO-106	VA-86	VCA-1159 ¹¹²	NS ⁴³⁷
------------	--------	-------	-------------------------	-------------------

Sentra

4 cyl. 1.8L FI	VO-106	VA-86	VCA-1068	NS ⁴³⁷
----------------	--------	-------	----------	-------------------

4 cyl. 2.5L FI	VO-106	VA-86	VCA-1068	NS ⁴³⁷
----------------	--------	-------	----------	-------------------

Titan

V8 5.6L FI	VO-106	VA-105	VCA-1048	NS ⁴³⁷
------------	--------	--------	----------	-------------------

Xtrail (Canada)

4 cyl. 2.5L FI	VO-106	VA-86	VCA-1068	NS ⁴³⁷
----------------	--------	-------	----------	-------------------

Xterra

V6 4.0L FI	VO-106	VA-105	VCA-1041	NS ⁴³⁷
------------	--------	--------	----------	-------------------

2004

350Z

V6 3.5L FI	VO-106	VA-86		NS ⁴³⁷
------------	--------	-------	--	-------------------

Altima

4 cyl. 2.5L FI	VO-106	VA-86	VCA-1068	NS ⁴³⁷
----------------	--------	-------	----------	-------------------

V6 3.5L FI	VO-106	VA-86	VCA-1068	NS ⁴³⁷
------------	--------	-------	----------	-------------------

Frontier

4 cyl. 2.4L FI	VO-106	VA-97		
----------------	--------	-------	--	--

V6 3.3L FI	VO-106	VA-86		
------------	--------	-------	--	--

Se reporter à table de matière pour les notes en bas de page en français. Utilize el contenido para ver notas a pie.

NS - Non-Serviceable / Non réparable / No repairable LF - Life-Time Filter / Filtro para toda la vida / Filtre à vie

¹¹² Requires two (2). ⁴³⁷ Requires replacement of the complete fuel pump/fuel filter module.



NISSAN (cont'd)

	Oil	Air	Cabin*	Fuel
2004				
Maxima				
V6 3.5L FI	VO-106	VA-86	VCA-1068	NS ⁴³⁷
Murano				
V6 3.5L FI	VO-106	VA-86	VCA-1068	NS ⁴³⁷
Pathfinder				
V6 3.5L FI	VO-106	VA-86	VCA-1039	
Pathfinder Armada				
V8 5.6L FI	VO-106	VA-105	VCA-1048	NS ⁴³⁷
Quest				
V6 3.5L FI	VO-106	VA-86	VCA-1159 ¹¹²	NS ⁴³⁷
Sentra				
4 cyl. 1.8L FI	VO-106	VA-86	VCA-1068	NS ⁴³⁷
4 cyl. 2.5L FI	VO-106	VA-86	VCA-1068	NS ⁴³⁷
Titan				
V8 5.6L FI	VO-106	VA-105	VCA-1048	NS ⁴³⁷
Xterra				
4 cyl. 2.4L FI	VO-106	VA-97		
V6 3.3L FI	VO-106	VA-86		
2003				
350Z				
V6 3.5L FI	VO-106	VA-86		NS ⁴³⁷
Altima				
4 cyl. 2.5L FI	VO-106	VA-86	VCA-1068	NS ⁴³⁷
V6 3.5L FI	VO-106	VA-86	VCA-1068	NS ⁴³⁷
Frontier				
4 cyl. 2.4L FI	VO-106	VA-97		
V6 3.3L FI	VO-106	VA-86		
Maxima				
V6 3.5L FI	VO-106	VA-86	VCA-1096	NS ⁴³⁷
Murano				
V6 3.5L FI	VO-106	VA-86	VCA-1068	NS ⁴³⁷
Pathfinder				
V6 3.5L FI	VO-106	VA-86	VCA-1039	
Sentra				
4 cyl. 1.8L FI	VO-106	VA-86	VCA-1068	NS ⁴³⁷
4 cyl. 2.5L FI	VO-106	VA-86	VCA-1068	NS ⁴³⁷
Xterra				
4 cyl. 2.4L FI	VO-106	VA-97		
V6 3.3L FI	VO-106	VA-86		
2002				
Altima				
4 cyl. 2.5L FI	VO-106	VA-86	VCA-1068	NS ⁴³⁷
V6 3.5L FI	VO-106	VA-86	VCA-1068	NS ⁴³⁷
Frontier				
4 cyl. 2.4L FI	VO-106	VA-97		
V6 3.3L FI	VO-106	VA-86		
Maxima				
V6 3.5L FI	VO-106	VA-86	VCA-1096	NS ⁴³⁷
Pathfinder				
V6 3.5L FI	VO-106	VA-86	VCA-1039	
Quest				
V6 3.3L FI	VO-106	VFAP-7857		

Se reporter à table de matière pour les notes en bas de page en français. Utilize el contenido para ver notas a pie.

NS - Non-Serviceable / Non réparable / No reparable LF - Life-Time Filter / Filtro para toda la vida / Filtre à vie

¹¹² Requires two (2). ⁴³⁷ Requires replacement of the complete fuel pump/fuel filter module.



NISSAN (cont'd)

2002

Sentra

4 cyl. 1.8L FI	VO-106	VA-86	VCA-1068	NS ⁴³⁷
4 cyl. 2.5L FI	VO-106	VA-86	VCA-1068	NS ⁴³⁷

Xterra

4 cyl. 2.4L FI	VO-106	VA-97		
V6 3.3L FI	VO-106	VA-86		

2001

Altima

4 cyl. 2.4L FI	VO-106	VA-86	VCA-1039	
----------------	--------	-------	----------	--

Frontier

4 cyl. 2.4L FI	VO-106	VA-97		
V6 3.3L FI	VO-106	VA-86		

Maxima

V6 3.0L FI	VO-106	VA-86	VCA-1096	NS ⁴³⁷
------------	--------	-------	----------	-------------------

Pathfinder

V6 3.5L FI	VO-106	VA-86	VCA-1039	
------------	--------	-------	----------	--

Quest

V6 3.3L FI	VO-106	VFAP-7857		
------------	--------	-----------	--	--

Sentra

4 cyl. 1.8L FI	VO-106	VA-86	VCA-1068	NS ⁴³⁷
4 cyl. 2.0L FI	VO-106	VA-86	VCA-1068	NS ⁴³⁷

Xterra

4 cyl. 2.4L FI	VO-106	VA-97		
V6 3.3L FI	VO-106	VA-86		

2000

Altima

4 cyl. 2.4L FI	VO-106	VA-86	VCA-1039	
----------------	--------	-------	----------	--

Frontier

4 cyl. 2.4L FI	VO-106	VA-97		
V6 3.3L FI	VO-106	VA-86		

Maxima

V6 3.0L FI	VO-106	VA-86	VCA-1096	NS ⁴³⁷
------------	--------	-------	----------	-------------------

Pathfinder

V6 3.3L FI	VO-106	VA-86	VCA-1039	
------------	--------	-------	----------	--

Quest

V6 3.3L FI	VO-106	VFAP-7857		
------------	--------	-----------	--	--

Sentra

4 cyl. 1.8L FI	VO-106	VA-86	VCA-1068	NS ⁴³⁷
4 cyl. 2.0L FI	VO-106	VA-86	VCA-1068	NS ⁴³⁷

Xterra

4 cyl. 2.4L FI	VO-106	VA-97		
V6 3.3L FI	VO-106	VA-86		

1999

Altima

4 cyl. 2.4L FI	VO-106	VA-86	VCA-1039	
----------------	--------	-------	----------	--

Frontier

4 cyl. 2.4L FI	VO-106	VA-97		
V6 3.3L FI	VO-106	VA-86		

Maxima

V6 3.0L FI	VO-106	VA-86		
------------	--------	-------	--	--

Pathfinder

V6 3.3L FI	VO-106	VA-86	VCA-1039	
------------	--------	-------	----------	--

Se reporter à table de matière pour les notes en bas de page en français. Utilize el contenido para ver notas a pie.

NS - Non-Serviceable / Non réparable / No repairable LF - Life-Time Filter / Filtro para toda la vida / Filtre à vie

⁴³⁷ Requires replacement of the complete fuel pump/fuel filter module.



NISSAN (cont'd)

	Oil	Air	Cabin*	Fuel
1999				
Quest				
V6 3.3L FI	VO-106	VFAP-7857		
Sentra				
4 cyl. 1.6L FI	VO-25	VA-86		
4 cyl. 2.0L FI	VO-106	VA-86		
1998				
200SX				
4 cyl. 1.6L (A) FI	VO-25	VA-86		
4 cyl. 2.0L (B) FI	VO-106	VA-86		
240SX				
4 cyl. 2.4L (A) FI	VO-25	VA-86		
Altima				
4 cyl. 2.4L FI	VO-106	VA-86	VCA-1039	
Frontier				
4 cyl. 2.4L FI	VO-106	VA-97		
Maxima				
V6 3.0L FI	VO-106	VA-86		
Pathfinder				
V6 3.3L FI	VO-106	VA-86	VCA-1039	
Quest				
V6 3.0L FI	VO-25	VFAP-7857		
Sentra				
4 cyl. 1.6L FI	VO-25	VA-86		
4 cyl. 2.0L FI	VO-106	VA-86		
1997				
200SX				
4 cyl. 1.6L (A) FI	VO-25	VA-86		
4 cyl. 2.0L (B) FI	VO-106	VA-86		
240SX				
4 cyl. 2.4L (A) FI	VO-25	VA-86		
Altima				
4 cyl. 2.4L FI	VO-25	VA-86		
Maxima				
V6 3.0L FI	VO-106	VA-86		
Pathfinder				
V6 3.3L FI	VO-106	VA-86	VCA-1039	
Pickup				
4 cyl. 2.4L FI	VO-25	VA-97		
Quest				
V6 3.0L FI	VO-25	VFAP-7857		
Sentra				
4 cyl. 1.6L FI	VO-25	VA-86		
1996				
200SX				
4 cyl. 1.6L (A) FI	VO-25	VA-86		
4 cyl. 2.0L (B) FI	VO-106	VA-86		
240SX				
4 cyl. 2.4L (A) FI	VO-25	VA-86		
300ZX				
V6 3.0L (R) FI Non Turbo	VO-25	VA-261 ¹¹²		
V6 3.0L (C) FI Turbo	VO-25	VA-261 ¹¹²		

Se reporter à table de matière pour les notes en bas de page en français. Utilize el contenido para ver notas a pie.

NS - Non-Serviceable / Non réparable / No reparable LF - Life-Time Filter / Filtro para toda la vida / Filtre à vie

¹¹² Requires two (2).



NISSAN (cont'd)

1996

Altima

4 cyl. 2.4L FI	VO-25	VA-86		
----------------	-------	-------	--	--

Maxima

V6 3.0L FI	VO-106	VA-86		
------------	--------	-------	--	--

Pathfinder

V6 3.3L FI	VO-106	VA-86		
------------	--------	-------	--	--

Pickup

4 cyl. 2.4L FI	VO-25	VA-97		
----------------	-------	-------	--	--

Quest

V6 3.0L FI	VO-25	VFAP-7857		
------------	-------	-----------	--	--

Sentra

4 cyl. 1.6L FI	VO-25	VA-86		
----------------	-------	-------	--	--

1995

200SX

4 cyl. 1.6L (A) FI	VO-25	VA-86		
--------------------	-------	-------	--	--

4 cyl. 2.0L (B) FI	VO-106	VA-86		
--------------------	--------	-------	--	--

240SX

4 cyl. 2.4L (A) FI	VO-25	VA-86		
--------------------	-------	-------	--	--

300ZX

V6 3.0L (R) FI Non Turbo	VO-25	VA-261 ¹¹²		
--------------------------	-------	-----------------------	--	--

V6 3.0L (C) FI Turbo	VO-25	VA-261 ¹¹²		
----------------------	-------	-----------------------	--	--

Altima

4 cyl. 2.4L FI	VO-25	VA-86		
----------------	-------	-------	--	--

Axxess

4 cyl. 2.4L FI (Canada)	VO-25	VA-86		
-------------------------	-------	-------	--	--

Maxima

V6 3.0L FI	VO-106	VA-86		
------------	--------	-------	--	--

Pathfinder

V6 3.0L FI	VO-25	VA-86		
------------	-------	-------	--	--

Pickup

4 cyl. 2.4L FI	VO-25	VA-97		
----------------	-------	-------	--	--

V6 3.0L FI	VO-25	VA-86		
------------	-------	-------	--	--

Quest

V6 3.0L FI	VO-25	VFAP-7857		
------------	-------	-----------	--	--

Sentra

4 cyl. 1.6L FI	VO-25	VA-86		
----------------	-------	-------	--	--

1994

300ZX

V6 3.0L (R) FI Non Turbo	VO-25	VA-261 ¹¹²		
--------------------------	-------	-----------------------	--	--

V6 3.0L (C) FI Turbo	VO-25	VA-261 ¹¹²		
----------------------	-------	-----------------------	--	--

OLDSMOBILE

2004

Alero

4 cyl. 2.2L (F) FI	VO-76	VA-91		VG-33
--------------------	-------	-------	--	-------

V6 3.4L (E) FI	VO-16	VA-91		VG-33
----------------	-------	-------	--	-------

Bravada

6 cyl. 4.2L (S) FI	VO-108	VA-161		
--------------------	--------	--------	--	--

Silhouette

V6 3.4L (E) FI	VO-16	VA-109	VCA-1164	
----------------	-------	--------	----------	--

Se reporter à table de matière pour les notes en bas de page en français. Utilize el contenido para ver notas a pie.

NS - Non-Serviceable / Non réparable / No reparable LF - Life-Time Filter / Filtro para toda la vida / Filtre à vie

¹¹² Requires two (2).



OLDSMOBILE (cont'd)

	Oil	Air	Cabin*	Fuel
2003				
Alero				
4 cyl. 2.2L (F) FI	VO-76	VA-91		VG-33
V6 3.4L (E) FI	VO-16	VA-91		VG-33
Aurora				
V8 4.0L (C) FI	VO-108	VA-109	VCA-1022 ^{X019} VCA-1165 ^{Z019}	VG-33
Bravada				
6 cyl. 4.2L (S) FI	VO-108	VA-161		
Silhouette				
V6 3.4L (E) FI	VO-16	VA-109	VCA-1164	
2002				
Alero				
4 cyl. 2.2L (F) FI	VO-76	VA-91		VG-33
V6 3.4L (E) FI	VO-16	VA-91		VG-33
Aurora				
V6 3.5L (H) FI	VO-67 ¹²⁰³	VA-109	VCA-1022 ^{X019} VCA-1165 ^{Z019}	VG-33
V8 4.0L (C) FI	VO-108	VA-109	VCA-1022 ^{X019} VCA-1165 ^{Z019}	VG-33
Bravada				
6 cyl. 4.2L (S) FI	VO-108	VA-161		
Intrigue				
V6 3.5L (H) FI	VO-67 ¹²⁰³	VA-78	VCA-1002	VG-33
Silhouette				
V6 3.4L (E) FI	VO-16	VA-109	VCA-1164	
2001				
Alero				
4 cyl. 2.4L (T) FI	VO-58	VA-91		VG-33
V6 3.4L (E) FI	VO-16	VA-91		VG-33
Aurora				
V6 3.5L (H) FI	VO-67 ¹²⁰³	VA-109	VCA-1022 ^{X019} VCA-1165 ^{Z019}	VG-33
V8 4.0L (C) FI	VO-108	VA-109	VCA-1022 ^{X019} VCA-1165 ^{Z019}	VG-33
Bravada				
V6 4.3L (W) FI	VO-55	VA-108		
Intrigue				
V6 3.5L (H) FI	VO-67 ¹²⁰³	VA-78	VCA-1002	VG-33
Silhouette				
V6 3.4L (E) FI	VO-16	VA-109	VCA-1164	
2000				
Alero				
4 cyl. 2.4L (T) FI	VO-58	VA-91		VG-33
V6 3.4L (E) FI	VO-16	VA-91		VG-33
Bravada				
V6 4.3L (W) FI	VO-55	VA-108		
Intrigue				
V6 3.5L (H) FI	VO-67 ¹²⁰³	VA-78	VCA-1002	VG-33
Silhouette				
V6 3.4L (E) FI	VO-16	VA-109	VCA-1021	

Se reporter à table de matière pour les notes en bas de page en français. Utilize el contenido para ver notas a pie.

NS - Non-Serviceable / Non réparable / No repairable LF - Life-Time Filter / Filtro para toda la vida / Filtre à vie

¹²⁰³Supplied O-ring not for 3.5L engine. Re-use Viton O-ring ^{X019}Dust filter. ^{Z019}Dust and odor filter.



OLDSMOBILE (cont'd)

1999

88 Royale, Regency, LSS

V6 3.8L (K) FI	VO-16	VA-78		VG-33
V6 3.8L (1) FI (S.C.)	VO-16	VA-78		VG-33

Alero

4 cyl. 2.4L (T) FI	VO-58	VA-91		VG-33
V6 3.4L (E) FI	VO-16	VA-91		VG-33

Aurora

V8 4.0L (C) FI	VO-108	VA-78		VG-33
----------------	--------	-------	--	-------

Bravada

V6 4.3L (W) FI	VO-55	VA-108		
----------------	-------	--------	--	--

Cutlass

V6 3.1L (J,M) FI	VO-16	VA-91		VG-33
------------------	-------	-------	--	-------

Intrigue

V6 3.5L (H) FI	VO-67 ¹²⁰³	VA-78	VCA-1002	VG-33
V6 3.8L (K) FI	VO-16	VA-109	VCA-1002	VG-33

Silhouette

V6 3.4L (E) FI	VO-16	VA-109	VCA-1021	
----------------	-------	--------	----------	--

1998

88 Royale, Regency, LSS

V6 3.8L (K) FI	VO-16	VA-78		VG-33
V6 3.8L (1) FI (S.C.)	VO-16	VA-78		VG-33

Achieva

4 cyl. 2.4L (T) FI	VO-58	VA-110		VG-33
V6 3.1L (M) FI	VO-16	VA-110		VG-33

Aurora

V8 4.0L (C) FI	VO-108	VA-78		VG-33
----------------	--------	-------	--	-------

Bravada

V6 4.3L (W) FI	VO-55	VA-108		
----------------	-------	--------	--	--

Cutlass

V6 3.1L (M) FI	VO-16	VA-91		VG-33
----------------	-------	-------	--	-------

Intrigue

V6 3.8L (K) FI	VO-16	VA-109	VCA-1002	VG-33
----------------	-------	--------	----------	-------

Silhouette

V6 3.4L (E) FI	VO-16	VA-109	VCA-1021	
----------------	-------	--------	----------	--

1997

88 Royale, Regency, LSS

V6 3.8L (K) FI	VO-16	VA-78		VG-33
V6 3.8L (1) FI (S.C.)	VO-16	VA-78		VG-33

Achieva

4 cyl. 2.4L (T) FI	VO-58	VA-110		VG-33
V6 3.1L (M) FI	VO-16	VA-110		VG-33

Aurora

V8 4.0L (C) FI	VO-108	VA-78		VG-33
----------------	--------	-------	--	-------

Bravada

V6 4.3L (W) FI	VO-55	VA-108		
----------------	-------	--------	--	--

Cutlass

V6 3.1L (M) FI	VO-16	VA-91		VG-33
----------------	-------	-------	--	-------

Cutlass Supreme

V6 3.1L (M) FI	VO-16	VA-109		VG-33
----------------	-------	--------	--	-------

Silhouette

V6 3.4L (E) FI	VO-16	VA-109	VCA-1021	
----------------	-------	--------	----------	--

--	--	--	--	--

Se reporter à table de matière pour les notes en bas de page en français. Utilize el contenido para ver notas a pie.

NS - Non-Serviceable / Non réparable / No reparable LF - Life-Time Filter / Filtro para toda la vida / Filtre à vie

¹²⁰³Supplied O-ring not for 3.5L engine. Re-use Viton O-ring



OLDSMOBILE (cont'd)

	Oil	Air	Cabin*	Fuel
1996				
88 Royale				
V6 3.8L (K) FI	VO-16	VA-78		VG-33
V6 3.8L (1) FI (S.C.)	VO-16	VA-78		VG-33
98 Regency				
V6 3.8L (K) FI	VO-16	VA-78		VG-33
Achieva				
4 cyl. 2.4L (T) FI	VO-58	VA-110		VG-33
V6 3.1L (M) FI	VO-16	VA-110		VG-33
Aurora				
V8 4.0L (C) FI	VO-108	VA-78		VG-33
Bravada				
V6 4.3L (W) FI	VO-55	VA-108		VG-14
Cutlass				
V6 3.1L (M) FI	VO-16	VA-109		VG-33
V6 3.4L (X) FI	VO-55	VA-109		VG-33
Cutlass Ciera				
4 cyl. 2.2L (4) FI	VO-16			
V6 3.1L (M) FI	VO-16	VA-85		
Silhouette				
V6 3.4L (E) FI	VO-16	VA-65		VG-30
1995				
88 Royale				
V6 3.8L (K)	VO-16	VA-78		VG-33
V6 3.8L (1) FI (S.C.)	VO-16	VA-78		VG-33
98 Regency				
V6 3.8L (K) FI	VO-16	VA-78		VG-33
V6 3.8L (1) FI (S.C.)	VO-16	VA-78		VG-33
Achieva				
4 cyl. 2.3L (D) FI	VO-16	VA-110		VG-33
V6 3.1L (M) FI	VO-16	VA-110		VG-33
Aurora				
V8 4.0L (C) FI	VO-108	VA-78		VG-33
Cutlass				
V6 3.1L (M) FI	VO-16	VA-109		VG-33
V6 3.4L (X) FI	VO-55	VA-109		VG-33
Cutlass Ciera				
4 cyl. 2.2L (4) FI	VO-16			
V6 3.1L (M)	VO-16	VA-85		
Silhouette				
V6 3.8L (L) FI	VO-16	VA-65		VG-30
PLYMOUTH				
2001				
Neon				
4 cyl. 2.0L (C) FI	VO-25	VA-137		NS ⁴³⁷
Prowler				
V6 3.5L (G) FI	VO-95 ^{X504} VO-25 ^{Z504}	VA-69		NS ⁴³⁷
2000				
Breeze				
4 cyl. 2.0L (C) FI	VO-25	VA-112		
4 cyl. 2.4L (X) FI	VO-25	VA-112		

Se reporter à table de matière pour les notes en bas de page en français. Utilize el contenido para ver notas a pie.

NS - Non-Serviceable / Non réparable / No repairable LF - Life-Time Filter / Filtro para toda la vida / Filtre à vie

⁴³⁷ Requires replacement of the complete fuel pump/fuel filter module. ^{X504}Alternate ^{Z504}Primary



PLYMOUTH (cont'd)

2000

Grand Voyager

V6 3.0L (3) FI	VO-95 ^{X504} VO-25 ^{Z504}	VA-69		
V6 3.3L (R) FI	VO-95 ^{X504} VO-25 ^{Z504}	VA-69		
V6 3.3L (G) FI (Flex Fuel)	VO-95 ^{X504} VO-25 ^{Z504}	VA-69		

Neon

4 cyl. 2.0L (C) FI	VO-25	VA-137		NS ⁴³⁷
--------------------	-------	--------	--	-------------------

Prowler

V6 3.5L (G) FI	VO-95 ^{X504} VO-25 ^{Z504}	VA-69		NS ⁴³⁷
----------------	--	-------	--	-------------------

Voyager

4 cyl. 2.4L (B) FI	VO-25	VA-69		
V6 3.0L (3) FI	VO-95 ^{X504} VO-25 ^{Z504}	VA-69		
V6 3.3L (R) FI	VO-95 ^{X504} VO-25 ^{Z504}	VA-69		
V6 3.3L (G) FI (Flex Fuel)	VO-95 ^{X504} VO-25 ^{Z504}	VA-69		

1999

Breeze

4 cyl. 2.0L (C) FI	VO-25	VA-112		
4 cyl. 2.4L (X) FI	VO-25	VA-112		

Grand Voyager

V6 3.0L (3) FI	VO-95 ^{X504} VO-25 ^{Z504}	VA-69		
V6 3.3L (R) FI	VO-95 ^{X504} VO-25 ^{Z504}	VA-69		
V6 3.3L (G) FI (Flex Fuel)	VO-95 ^{X504} VO-25 ^{Z504}	VA-69		
V6 3.8L (L) FI	VO-95 ^{X504} VO-25 ^{Z504}	VA-69		

Neon

4 cyl. 2.0L (C,Y) FI	VO-25	VA-69		NS ⁴³⁷
----------------------	-------	-------	--	-------------------

Prowler

V6 3.5L FI	VO-95 ^{X504} VO-25 ^{Z504}	VA-69		NS ⁴³⁷
------------	--	-------	--	-------------------

Voyager

4 cyl. 2.4L (B) FI	VO-25	VA-69		
V6 3.0L (3) FI	VO-95 ^{X504} VO-25 ^{Z504}	VA-69		
V6 3.3L (R) FI	VO-95 ^{X504} VO-25 ^{Z504}	VA-69		
V6 3.3L (G) FI (Flex Fuel)	VO-95 ^{X504} VO-25 ^{Z504}	VA-69		
V6 3.8L (L) FI	VO-95 ^{X504} VO-25 ^{Z504}	VA-69		

1998

Breeze

4 cyl. 2.0L (C) FI	VO-25	VA-112		
4 cyl. 2.4L (X) FI	VO-25	VA-112		

Se reporter à table de matière pour les notes en bas de page en français. Utilize el contenido para ver notas a pie.

NS - Non-Serviceable / Non réparable / No repairable LF - Life-Time Filter / Filtro para toda la vida / Filtre à vie

⁴³⁷ Requires replacement of the complete fuel pump/fuel filter module. ^{X504}Alternate ^{Z504}Primary



PLYMOUTH (cont'd)

1998				
Grand Voyager				
V6 3.0L (3) FI	VO-95 ^{X504} VO-25 ^{Z504}	VA-69		
V6 3.3L (R) FI	VO-95 ^{X504} VO-25 ^{Z504}	VA-69		
V6 3.3L (G) FI (Flex Fuel)	VO-95 ^{X504} VO-25 ^{Z504}	VA-69		
V6 3.8L (L) FI	VO-95 ^{X504} VO-25 ^{Z504}	VA-69		
Neon				
4 cyl. 2.0L (C,Y) FI	VO-25	VA-69		NS ⁴³⁷
Voyager				
4 cyl. 2.4L (B) FI	VO-25	VA-69		
V6 3.0L (3) FI	VO-95 ^{X504} VO-25 ^{Z504}	VA-69		
V6 3.3L (R) FI	VO-95 ^{X504} VO-25 ^{Z504}	VA-69		
V6 3.3L (G) FI (Flex Fuel)	VO-95 ^{X504} VO-25 ^{Z504}	VA-69		
V6 3.8L (L) FI	VO-95 ^{X504} VO-25 ^{Z504}	VA-69		
1997				
Breeze				
4 cyl. 2.0L (C) FI	VO-25	VA-112		
4 cyl. 2.4L (X) FI	VO-25	VA-112		
Grand Voyager				
4 cyl. 2.4L (B) FI	VO-25	VA-69		
V6 3.0L (3) FI	VO-95 ^{X504} VO-25 ^{Z504}	VA-69		
V6 3.3L (R) FI	VO-95 ^{X504} VO-25 ^{Z504}	VA-69		
V6 3.8L (L) FI	VO-95 ^{X504} VO-25 ^{Z504}	VA-69		
Neon				
4 cyl. 2.0L (C,Y) FI	VO-25	VA-69		NS
Prowler				
V6 3.5L FI	VO-95 ^{X504} VO-25 ^{Z504}	VA-69		NS ⁴³⁷
Voyager				
4 cyl. 2.4L (B) FI	VO-25	VA-69		
V6 3.0L (3) FI	VO-95 ^{X504} VO-25 ^{Z504}	VA-69		
V6 3.3L (R) FI	VO-95 ^{X504} VO-25 ^{Z504}	VA-69		
V6 3.8L (L) FI	VO-95 ^{X504} VO-25 ^{Z504}	VA-69		
1996				
Breeze				
4 cyl. 2.0L (C) FI	VO-25	VA-112		
4 cyl. 2.4L (X) FI	VO-25	VA-112		
Grand Voyager				
4 cyl. 2.4L (B) FI	VO-25	VA-69		

Se reporter à table de matière pour les notes en bas de page en français. Utilize el contenido para ver notas a pie.

NS - Non-Serviceable / Non réparable / No reparable LF - Life-Time Filter / Filtro para toda la vida / Filtre à vie

⁴³⁷ Requires replacement of the complete fuel pump/fuel filter module. ^{X504}Alternate ^{Z504}Primary



PLYMOUTH (cont'd)

1996

Grand Voyager

V6 3.0L (3) FI	VO-95 ^{X504} VO-25 ^{Z504}	VA-69		
V6 3.3L (R) FI	VO-95 ^{X504} VO-25 ^{Z504}	VA-69		
V6 3.3L (J) FI (CNG)	VO-95 ^{X504} VO-25 ^{Z504}	VA-69		
V6 3.8L (L) FI	VO-95 ^{X504} VO-25 ^{Z504}	VA-69		

Neon

4 cyl. 2.0L (C,Y) FI	VO-25	VA-69		
----------------------	-------	-------	--	--

Voyager

4 cyl. 2.4L (B) FI	VO-25	VA-69		
V6 3.0L (3) FI	VO-95 ^{X504} VO-25 ^{Z504}	VA-69		
V6 3.3L (R) FI	VO-95 ^{X504} VO-25 ^{Z504}	VA-69		
V6 3.3L (J) FI (CNG)	VO-95 ^{X504} VO-25 ^{Z504}	VA-69		

1995

Acclaim

4 cyl. 2.5L (K) FI	VO-95 ^{X504} VO-25 ^{Z504}			
V6 3.0L (3) FI	VO-95 ^{X504} VO-25 ^{Z504}	VA-69		

Colt

4 cyl. 1.5L FI	VO-106	VA-387		
----------------	--------	--------	--	--

Neon

4 cyl. 2.0L (C,Y) FI	VO-25	VA-69		
----------------------	-------	-------	--	--

Voyager

4 cyl. 2.5L (K) FI	VO-95 ^{X504} VO-25 ^{Z504}	VA-40		
V6 3.0L (3) FI	VO-95 ^{X504} VO-25 ^{Z504}	VA-69		
V6 3.3L (R) FI	VO-95 ^{X504} VO-25 ^{Z504}	VA-40		
V6 3.3L (J) FI (CNG)	VO-95 ^{X504} VO-25 ^{Z504}	VA-40		
V6 3.8L (L) FI	VO-95 ^{X504} VO-25 ^{Z504}	VA-40		

PONTIAC

2010

G3

4 cyl. 1.6L (E) FI	VO-98	VA-188	VCA-1146	NS ⁴³⁷
--------------------	-------	--------	----------	-------------------

G5

4 cyl 2.2L (H) FI	VO-76	VA-203	VCA-1065	
-------------------	-------	--------	----------	--

G6

4 cyl 2.4L (B) FI	VO-76	VA-176		NS ⁴³⁷
4 cyl 2.4L (O) FI (Flex Fuel)	VO-76	VA-176		NS ⁴³⁷
V6 3.5L (N) FI	VO-108	VA-269 ^{X492} VA-176 ^{Z492}		NS ⁴³⁷
V6 3.5L (K) FI (Flex Fuel)	VO-108	VA-269		NS ⁴³⁷

Se reporter à table de matière pour les notes en bas de page en français. Utilize el contenido para ver notas a pie.

NS - Non-Serviceable / Non réparable / No reparable LF - Life-Time Filter / Filtro para toda la vida / Filtre à vie

⁴³⁷ Requires replacement of the complete fuel pump/fuel filter module. ^{X492}11.50 x 7 inch filter ^{X504}Alternate ^{Z492}11 x 9.35 inch filter ^{Z504}Primary



PONTIAC (cont'd)

	Oil	Air	Cabin*	Fuel
2010				
Vibe				
4 cyl. 1.8L (8) FI	VO-102	VA-231	VCA-1031	NS ⁴³⁷
4 cyl. 2.4L (0) FI	VO-40	VA-209	VCA-1031	NS ⁴³⁷
2009				
G3				
4 cyl. 1.6L (E) FI	VO-98	VA-188	VCA-1146	NS ⁴³⁷
G3 Wave (Canada)				
4 cyl. 1.6L (E) FI	VO-98	VA-188	VCA-1146	NS ⁴³⁷
G5				
4 cyl. 2.2L (H) FI	VO-76	VA-203	VCA-1065	
G6				
4 cyl. 2.4L (B) FI	VO-76	VA-176		NS ⁴³⁷
V6 3.5L (N) FI	VO-108	VA-269 ^{X492} VA-176 ^{Z492}		NS ⁴³⁷
V6 3.5L (K) FI (Flex Fuel)	VO-108	VA-269		NS ⁴³⁷
V6 3.6L (7) FI	VO-88	VA-176		NS ⁴³⁷
V6 3.9L (1) FI	VO-108	VA-269		NS ⁴³⁷
G8				
V6 3.6L (7) FI	VO-67	VA-375		
V8 6.0L (Y) FI	VO-88	VA-375		
V8 6.2L (W) FI	VO-88	VA-375		
Montana SV6				
V6 3.9L (1) FI	VO-108	VA-109	VCA-1164	NS ⁴³⁷
V6 3.9L (W) FI (Flex Fuel)	VO-108	VA-109	VCA-1164	NS ⁴³⁷
Solstice				
4 cyl. 2.0L (X) FI Turbo	VO-76	VA-360		NS ⁴³⁷
4 cyl. 2.4L (B) FI	VO-76	VA-360		NS ⁴³⁷
Torrent				
V6 3.4L (F) FI	VO-16	VA-176	VCA-1030	NS ⁴³⁷
V6 3.6L (7) FI	VO-88	VA-176	VCA-1030	NS ⁴³⁷
Vibe				
4 cyl. 1.8L (8) FI	VO-102	VA-231	VCA-1031	NS ⁴³⁷
4 cyl. 2.4L (0) FI	VO-40	VA-209	VCA-1031	NS ⁴³⁷
2008				
G5				
4 cyl. 2.2L (F) FI	VO-76	VA-203	VCA-1065	
4 cyl. 2.4L (B) FI	VO-76	VA-203	VCA-1065	
G6				
4 cyl. 2.4L (B) FI	VO-76	VA-269 ^{X492} VA-176 ^{Z492}		NS ⁴³⁷
V6 3.5L (N) FI	VO-108	VA-269		NS ⁴³⁷
V6 3.6L (7) FI	VO-88	VA-176		NS ⁴³⁷
V6 3.9L (1) FI	VO-108	VA-269		NS ⁴³⁷
G8				
V6 3.6L (7) FI	VO-67	VA-375		
V8 6.0L (Y) FI	VO-88	VA-375		
Grand Prix				
V6 3.8L (2) FI	VO-16	VA-78	VCA-1002	NS ⁴³⁷
V8 5.3L (C) FI	VO-88	VA-200	VCA-1002	NS ⁴³⁷
Montana SV6				
V6 3.9L (1) FI	VO-108	VA-109	VCA-1164	NS ⁴³⁷
V6 3.9L (W) FI (Flex Fuel)	VO-108	VA-109	VCA-1164	NS ⁴³⁷

Se reporter à table de matière pour les notes en bas de page en français. Utilize el contenido para ver notas a pie.

NS - Non-Serviceable / Non réparable / No reparable LF - Life-Time Filter / Filtro para toda la vida / Filtre à vie

⁴³⁷ Requires replacement of the complete fuel pump/fuel filter module. ^{X492}11.50 x 7 inch filter ^{Z492}11 x 9.35 inch filter



PONTIAC (cont'd)

2008

Solstice

4 cyl. 2.0L (X) FI Turbo	VO-76	VA-360		NS ⁴³⁷
4 cyl. 2.4L (B) FI	VO-76	VA-360		NS ⁴³⁷

Torrent

V6 3.4L (F) FI	VO-16	VA-176	VCA-1030	NS ⁴³⁷
V6 3.6L (7) FI	VO-88	VA-176	VCA-1030	NS ⁴³⁷

Vibe

4 cyl. 1.8L (8) FI (1ZZFE)	VO-40	VA-171	VCA-1037	NS ⁴³⁷
----------------------------	-------	--------	----------	-------------------

Wave (Canada)

4 cyl 1.6L (6) FI	VO-16	VA-188	VCA-1146	NS ⁴³⁷
-------------------	-------	--------	----------	-------------------

2007

G5

4 cyl 2.2L (F) FI	VO-76	VA-203	VCA-1065	
4 cyl. 2.4L (B) FI	VO-76	VA-203	VCA-1065	

G6

4 cyl 2.4L (B) FI	VO-76	VA-269		NS ⁴³⁷
V6 3.5L (N) FI	VO-108	VA-269		NS ⁴³⁷
V6 3.6L (7) FI	VO-88	VA-176		NS ⁴³⁷
V6 3.9L (1) FI	VO-108	VA-269		NS ⁴³⁷

Grand Prix

V6 3.8L (2) FI	VO-16	VA-78	VCA-1002	NS ⁴³⁷
V6 3.8L (4) FI (S.C.)	VO-16	VA-78	VCA-1002	NS ⁴³⁷
V8 5.3L (C) FI	VO-88	VA-200	VCA-1002	NS ⁴³⁷

Montana SV6

V6 3.9L (1) FI	VO-108	VA-109	VCA-1164	NS ⁴³⁷
----------------	--------	--------	----------	-------------------

Solstice

4 cyl. 2.0L (X) FI Turbo	VO-76	VA-360		NS ⁴³⁷
4 cyl. 2.4L (B) FI	VO-76	VA-360		NS ⁴³⁷

Torrent

V6 3.4L (F) FI	VO-16	VA-176	VCA-1030	NS ⁴³⁷
----------------	-------	--------	----------	-------------------

Vibe

4 cyl. 1.8L (8) FI (1ZZFE)	VO-40	VA-171	VCA-1037	NS ⁴³⁷
----------------------------	-------	--------	----------	-------------------

Wave (Canada)

4 cyl 1.6L FI	VO-16	VA-188	VCA-1146	NS ⁴³⁷
---------------	-------	--------	----------	-------------------

2006

G6

4 cyl 2.4L (B) FI	VO-76	VA-269		NS ⁴³⁷
V6 3.5L (8) FI	VO-16	VA-269		NS ⁴³⁷
V6 3.9L (1) FI	VO-108	VA-269		NS ⁴³⁷

Grand Prix

V6 3.8L (2) FI	VO-16	VA-78	VCA-1002	NS ⁴³⁷
V6 3.8L (4) FI (S.C.)	VO-16	VA-78	VCA-1002	NS ⁴³⁷
V8 5.3L (C) FI	VO-58	VA-200	VCA-1002	NS ⁴³⁷

GTO

V8 6.0L (U)	VO-58			NS ⁴³⁷
-------------	-------	--	--	-------------------

Montana SV6

V6 3.5L (L) FI	VO-16	VA-109	VCA-1164	NS ⁴³⁷
V6 3.9L (1) FI	VO-108	VA-109	VCA-1164	NS ⁴³⁷

Pursuit (Canada)

4 cyl 2.2L (F) FI	VO-76	VA-203	VCA-1065	
4 cyl. 2.4L (B) FI	VO-76	VA-203	VCA-1065	

Se reporter à table de matière pour les notes en bas de page en français. Utilize el contenido para ver notas a pie.

NS - Non-Serviceable / Non réparable / No reparable LF - Life-Time Filter / Filtro para toda la vida / Filtre à vie

⁴³⁷ Requires replacement of the complete fuel pump/fuel filter module.



PONTIAC (cont'd)

	Oil	Air	Cabin*	Fuel
2006				
Solstice				
4 cyl. 2.4L (B) FI	VO-76	VA-360		NS ⁴³⁷
Torrent				
V6 3.4L (F) FI	VO-16	VA-176	VCA-1030	NS ⁴³⁷
Vibe				
4 cyl. 1.8L (8) FI (1ZZFE)	VO-40	VA-171	VCA-1037	NS ⁴³⁷
4 cyl. 1.8L (L) FI (2ZZGE)	VO-40	VA-171	VCA-1037	NS ⁴³⁷
Wave (Canada)				
4 cyl. 1.6L FI	VO-16	VA-188	VCA-1146	
2005				
Aztek				
V6 3.4L (E) FI	VO-16	VA-109	VCA-1164	
Bonneville				
V6 3.8L (K) FI	VO-16	VA-78	VCA-1022 ^{X133} VCA-1022K ^{Z133} VCA-1165 ^{Y133}	VG-33
V8 4.6L (Y) FI	VO-108	VA-109	VCA-1022 ^{X133} VCA-1022K ^{Z133} VCA-1165 ^{Y133}	VG-33
G6				
V6 3.5L (8)	VO-16	VA-269		NS ⁴³⁷
Grand AM				
4 cyl. 2.2L (F) FI	VO-76	VA-91		VG-33
V6 3.4L (E) FI	VO-16	VA-91		VG-33
Grand Prix				
V6 3.8L (2) FI	VO-16	VA-78	VCA-1002	NS ⁴³⁷
V6 3.8L (4) FI (S.C.)	VO-16	VA-78	VCA-1002	NS ⁴³⁷
V8 5.3L (C) FI	VO-58	VA-200	VCA-1002	NS ⁴³⁷
GTO				
V8 6.0L (U)	VO-58			NS ⁴³⁷
Montana				
V6 3.4L (E) FI	VO-16	VA-109	VCA-1164	
Montana SV6				
V6 3.5L (L) FI	VO-16	VA-109	VCA-1164	NS ⁴³⁷
Pursuit (Canada)				
4 cyl. 2.2L (F) FI	VO-76	VA-203	VCA-1065	
Sunfire				
4 cyl. 2.2L (F) FI	VO-76	VA-65		VG-33
Vibe				
4 cyl. 1.8L (8) FI (1ZZFE)	VO-40	VA-171	VCA-1037	NS ⁴³⁷
4 cyl. 1.8L (L) FI (2ZZGE)	VO-40	VA-171	VCA-1037	NS ⁴³⁷
Wave (Canada)				
4 cyl. 1.6L FI	VO-16	VA-188	VCA-1146	
2004				
Aztek				
V6 3.4L (E) FI	VO-16	VA-109	VCA-1164	
Bonneville				
V6 3.8L (K) FI	VO-16	VA-78	VCA-1022 ^{X133} VCA-1022K ^{Z133} VCA-1165 ^{Y133}	VG-33

Se reporter à table de matière pour les notes en bas de page en français. Utilize el contenido para ver notas a pie.

NS - Non-Serviceable / Non réparable / No reparable LF - Life-Time Filter / Filtro para toda la vida / Filtre à vie

⁴³⁷ Requires replacement of the complete fuel pump/fuel filter module. ^{X133}Dust filter. ^{Y133}Dust and odor filter ^{Z133}Dust filter and housing.



PONTIAC (cont'd)

2004

Bonneville

V8 4.6L (Y) FI	VO-108	VA-109	VCA-1022 ^{X133} VCA-1022K ^{Z133} VCA-1165 ^{Y133}	VG-33
----------------	--------	--------	---	-------

Grand AM

4 cyl. 2.2L (F) FI	VO-76	VA-91		VG-33
V6 3.4L (E) FI	VO-16	VA-91		VG-33

Grand Prix

V6 3.8L (2) FI	VO-16	VA-78	VCA-1002	
V6 3.8L (4) FI (S.C.)	VO-16	VA-78	VCA-1002	

GTO

V8 5.7L	VO-58			NS ⁴³⁷
---------	-------	--	--	-------------------

Montana

V6 3.4L (E) FI	VO-16	VA-109	VCA-1164	
----------------	-------	--------	----------	--

Sunfire

4 cyl. 2.2L (F) FI	VO-76	VA-65		VG-33
--------------------	-------	-------	--	-------

Vibe

4 cyl. 1.8L (8) FI (1ZZFE)	VO-40	VA-171	VCA-1037	NS ⁴³⁷
4 cyl. 1.8L (L) FI (2ZZGE)	VO-40	VA-171	VCA-1037	NS ⁴³⁷

2003

Aztek

V6 3.4L (E) FI	VO-16	VA-109	VCA-1164	
----------------	-------	--------	----------	--

Bonneville

V6 3.8L (K) FI	VO-16	VA-78	VCA-1022 ^{X133} VCA-1022K ^{Z133} VCA-1165 ^{Y133}	VG-33
V6 3.8L (1) FI (S.C.)	VO-16	VA-78	VCA-1022 ^{X133} VCA-1022K ^{Z133} VCA-1165 ^{Y133}	VG-33

Grand AM

4 cyl. 2.2L (F) FI	VO-76	VA-91		VG-33
V6 3.4L (E) FI	VO-16	VA-91		VG-33

Grand Prix

V6 3.1L (J) FI	VO-16	VA-78		VG-33
V6 3.8L (K) FI	VO-16	VA-78		VG-33
V6 3.8L (1) FI (S.C.)	VO-16	VA-78		VG-33

Montana

V6 3.4L (E) FI	VO-16	VA-109	VCA-1164	
----------------	-------	--------	----------	--

Sunfire

4 cyl. 2.2L (F) FI	VO-76	VA-65		VG-33
--------------------	-------	-------	--	-------

Vibe

4 cyl. 1.8L (8) FI (1ZZFE)	VO-40	VA-171	VCA-1037	NS ⁴³⁷
4 cyl. 1.8L (L) FI (2ZZGE)	VO-40	VA-171	VCA-1037	NS ⁴³⁷

2002

Aztek

V6 3.4L (E) FI	VO-16	VA-109	VCA-1164	
----------------	-------	--------	----------	--

Bonneville

V6 3.8L (K) FI	VO-16	VA-78	VCA-1022 ^{X133} VCA-1022K ^{Z133} VCA-1165 ^{Y133}	VG-33
V6 3.8L (1) FI (S.C.)	VO-16	VA-78	VCA-1022 ^{X133} VCA-1022K ^{Z133} VCA-1165 ^{Y133}	VG-33

Se reporter à table de matière pour les notes en bas de page en français. Utilize el contenido para ver notas a pie.

NS - Non-Serviceable / Non réparable / No repairable LF - Life-Time Filter / Filtro para toda la vida / Filtre à vie

⁴³⁷ Requires replacement of the complete fuel pump/fuel filter module. ^{X133}Dust filter. ^{Y133}Dust and odor filter ^{Z133}Dust filter and housing.



PONTIAC (cont'd)

	Oil	Air	Cabin*	Fuel
2002				
Firebird				
V6 3.8L (K) FI	VO-16	VFAP-917		VG-33
V8 5.7L (G) FI	VO-58	VFAP-917		VG-33
Grand AM				
4 cyl. 2.2L (F) FI	VO-76	VA-91		VG-33
V6 3.4L (E) FI	VO-16	VA-91		VG-33
Grand Prix				
V6 3.1L (J) FI	VO-16	VA-78		VG-33
V6 3.8L (K) FI	VO-16	VA-78		VG-33
V6 3.8L (1) FI (S.C.)	VO-16	VA-78		VG-33
Montana				
V6 3.4L (E) FI	VO-16	VA-109	VCA-1164	
Sunfire				
4 cyl. 2.2L (4) FI	VO-16	VA-65		VG-33
4 cyl. 2.2L (F) FI	VO-76	VA-65		VG-33
4 cyl. 2.4L (T) FI	VO-58	VA-65		VG-33
2001				
Aztek				
V6 3.4L (E) FI	VO-16	VA-109	VCA-1164	
Bonneville				
V6 3.8L (K) FI	VO-16	VA-78	VCA-1022 ^{X133} VCA-1022K ^{Z133} VCA-1165 ^{Y133}	VG-33
V6 3.8L (1) FI (S.C.)	VO-16	VA-78	VCA-1022 ^{X133} VCA-1022K ^{Z133} VCA-1165 ^{Y133}	VG-33
Firebird				
V6 3.8L (K) FI	VO-16	VFAP-917		VG-33
V8 5.7L (G) FI	VO-58	VFAP-917		VG-33
Grand AM				
4 cyl. 2.4L (T) FI	VO-58	VA-91		VG-33
V6 3.4L (E) FI	VO-16	VA-91		VG-33
Grand Prix				
V6 3.1L (J) FI	VO-16	VA-78		VG-33
V6 3.8L (K) FI	VO-16	VA-78		VG-33
V6 3.8L (1) FI (S.C.)	VO-16	VA-78		VG-33
Montana				
V6 3.4L (E) FI	VO-16	VA-109	VCA-1164	
Sunfire				
4 cyl. 2.2L (4) FI	VO-16	VA-65		VG-33
4 cyl. 2.4L (T) FI	VO-58	VA-65		VG-33
2000				
Bonneville				
V6 3.8L (K) FI	VO-16	VA-78	VCA-1022 ^{X133} VCA-1022K ^{Z133} VCA-1165 ^{Y133}	VG-33
V6 3.8L (1) FI (S.C.)	VO-16	VA-78	VCA-1022 ^{X133} VCA-1022K ^{Z133} VCA-1165 ^{Y133}	VG-33
Firebird				
V6 3.8L (K) FI	VO-16	VFAP-917		VG-33
V8 5.7L (G) FI	VO-58	VFAP-917		VG-33

Se reporter à table de matière pour les notes en bas de page en français. Utilize el contenido para ver notas a pie.

NS - Non-Serviceable / Non réparable / No reparable LF - Life-Time Filter / Filtro para toda la vida / Filtre à vie

^{X133}Dust filter. ^{Y133}Dust and odor filter ^{Z133}Dust filter and housing.



PONTIAC (cont'd)

2000

Firefly (Canada)

3 cyl. 1.0L (6) FI	VO-25			
4 cyl. 1.3L (2) FI	VO-25			

Grand AM

4 cyl. 2.4L (T) FI	VO-58	VA-91		VG-33
V6 3.4L (E) FI	VO-16	VA-91		VG-33

Grand Prix

V6 3.1L (J) FI	VO-16	VA-78		VG-33
V6 3.8L (K) FI	VO-16	VA-78		VG-33
V6 3.8L (1) FI (S.C.)	VO-16	VA-78		VG-33

Montana

V6 3.4L (E) FI	VO-16	VA-109	VCA-1021	
----------------	-------	--------	----------	--

Sunfire

4 cyl. 2.2L (4) FI	VO-16	VA-65		VG-33
4 cyl. 2.4L (T) FI	VO-58	VA-65		VG-33

1999

Bonneville

V6 3.8L (K) FI	VO-16	VA-78		VG-33
V6 3.8L (1) FI (S.C.)	VO-16	VA-78		VG-33

Firebird

V6 3.8L (K) FI	VO-16	VFAP-917		VG-33
V8 5.7L (G) FI	VO-58	VFAP-917		VG-33

Firefly (Canada)

3 cyl. 1.0L (6) FI	VO-25			
4 cyl. 1.3L (2) FI	VO-25			

Grand AM

4 cyl. 2.4L (T) FI	VO-58	VA-91		VG-33
V6 3.4L (E) FI	VO-16	VA-91		VG-33

Grand Prix

V6 3.1L (M) FI	VO-16	VA-78		VG-33
V6 3.8L (K) FI	VO-16	VA-78		VG-33
V6 3.8L (1) FI (S.C.)	VO-16	VA-78		VG-33

Montana

V6 3.4L (E) FI	VO-16	VA-109	VCA-1021	
----------------	-------	--------	----------	--

Sunfire

4 cyl. 2.2L (4) FI	VO-16	VA-65		VG-33
4 cyl. 2.4L (T) FI	VO-58	VA-65		VG-33

Trans Sport

V6 3.4L (E) FI (Canada)	VO-16	VA-109	VCA-1021	
-------------------------	-------	--------	----------	--

1998

Bonneville

V6 3.8L (K) FI	VO-16	VA-78		VG-33
V6 3.8L (1) FI (S.C.)	VO-16	VA-78		VG-33

Firebird

V6 3.8L (K) FI	VO-16	VFAP-917		VG-33
V8 5.7L (G) FI	VO-58	VFAP-917		VG-33

Firefly (Canada)

3 cyl. 1.0L (6) FI	VO-25			
4 cyl. 1.3L (2) FI	VO-25			

Grand AM

4 cyl. 2.4L (T) FI	VO-58	VA-110		VG-33
V6 3.1L (M) FI	VO-16	VA-110		VG-33

Se reporter à table de matière pour les notes en bas de page en français. Utilize el contenido para ver notas a pie.

NS - Non-Serviceable / Non réparable / No reparable LF - Life-Time Filter / Filtro para toda la vida / Filtre à vie



PONTIAC (cont'd)

	Oil	Air	Cabin*	Fuel
1998				
Grand Prix				
V6 3.1L (M) FI	VO-16	VA-109		VG-33
V6 3.8L (K) FI	VO-16	VA-109		VG-33
V6 3.8L (1) FI (S.C.)	VO-16	VA-109		VG-33
Sunfire				
4 cyl. 2.2L (4) FI	VO-16	VA-65		VG-33
4 cyl. 2.4L (T) FI	VO-58	VA-65		VG-33
Trans Sport				
V6 3.4L (E) FI	VO-16	VA-109	VCA-1021	
1997				
Bonneville				
V6 3.8L (K) FI	VO-16	VA-78		VG-33
V6 3.8L (1) FI (S.C.)	VO-16	VA-78		VG-33
Firebird				
V6 3.8L (K) FI	VO-16	VA-108 ¹⁸⁶		VG-33
V8 5.7L (P) FI	VO-65	VA-108 ¹⁸⁶		VG-33
Firefly (Canada)				
3 cyl. 1.0L (6) FI	VO-25			
4 cyl. 1.3L (9) FI	VO-25			
Grand AM				
4 cyl. 2.4L (T) FI	VO-58	VA-110		VG-33
V6 3.1L (M) FI	VO-16	VA-110		VG-33
Grand Prix				
V6 3.1L (M) FI	VO-16	VA-109		VG-33
V6 3.8L (K) FI	VO-16	VA-109		VG-33
V6 3.8L (1) FI (S.C.)	VO-16	VA-109		VG-33
Sunfire				
4 cyl. 2.2L (4) FI	VO-16	VA-65		VG-33
4 cyl. 2.4L (T) FI	VO-58	VA-65		VG-33
Sunrunner (Canada)				
L4 1.6L (6) FI	VO-25			
Trans Sport				
V6 3.4L (E) FI	VO-16	VA-109	VCA-1021	
1996				
Bonneville				
V6 3.8L (K) FI	VO-16	VA-78		VG-33
V6 3.8L (1) FI (S.C.)	VO-16	VA-78		VG-33
Firebird				
V6 3.8L (K) FI	VO-16	VA-108		VG-33
V8 5.7L (P) FI	VO-65	VA-108 ¹⁸⁶		VG-33
Firefly (Canada)				
3 cyl. 1.0L (6) FI	VO-25			
4 cyl. 1.3L (9) FI	VO-25			
Grand AM				
4 cyl. 2.4L (T) FI	VO-58	VA-110		VG-33
V6 3.1L (M) FI	VO-16	VA-110		VG-33
Grand Prix				
V6 3.1L (M) FI	VO-16	VA-109		VG-33
V6 3.4L (X) FI	VO-55	VA-109		VG-33
Sunfire				
4 cyl. 2.2L (4) FI	VO-16	VA-65		VG-33
4 cyl. 2.4L (T) FI	VO-58	VA-65		VG-33

Se reporter à table de matière pour les notes en bas de page en français. Utilize el contenido para ver notas a pie.

NS - Non-Serviceable / Non réparable / No repairable LF - Life-Time Filter / Filtro para toda la vida / Filtre à vie

¹⁸⁶ Except special performance.



PONTIAC (cont'd)

1996

Sunrunner (Canada)

L4 1.6L (6) FI	VO-25			
----------------	-------	--	--	--

Trans Sport

V6 3.4L (E) FI	VO-16	VA-65	VCA-1021	VG-30
----------------	-------	-------	----------	-------

1995

Bonneville

V6 3.8L (K) FI	VO-16	VA-78		VG-33
----------------	-------	-------	--	-------

V6 3.8L (1) FI (S.C.)	VO-16	VA-78		VG-33
-----------------------	-------	-------	--	-------

Firebird

V6 3.4L (S) FI	VO-16	VA-108		VG-33
----------------	-------	--------	--	-------

V6 3.8L (K) FI	VO-16	VA-108		VG-33
----------------	-------	--------	--	-------

V8 5.7L (P) FI	VO-65	VA-108		VG-33
----------------	-------	--------	--	-------

Firefly (Canada)

3 cyl. 1.0L (6) FI	VO-25			
--------------------	-------	--	--	--

4 cyl. 1.3L (9) FI	VO-25			
--------------------	-------	--	--	--

Grand AM

4 cyl. 2.3L (D) FI	VO-16	VA-110		VG-33
--------------------	-------	--------	--	-------

V6 3.1L (M) FI	VO-16	VA-110		VG-33
----------------	-------	--------	--	-------

Grand Prix

V6 3.1L (M) FI	VO-16	VA-109		VG-33
----------------	-------	--------	--	-------

V6 3.4L (X) FI	VO-55	VA-109		VG-33
----------------	-------	--------	--	-------

Sunfire

4 cyl. 2.2L (4) FI	VO-16	VA-65		VG-33
--------------------	-------	-------	--	-------

4 cyl. 2.3L (D) FI	VO-16	VA-65		VG-33
--------------------	-------	-------	--	-------

Sunrunner (Canada)

L4 1.6L (6) FI	VO-25			
----------------	-------	--	--	--

Trans Sport

V6 3.1L (D) FI	VO-55	VA-38		VG-30
----------------	-------	-------	--	-------

V6 3.8L (L) FI	VO-16	VA-65		VG-30
----------------	-------	-------	--	-------

PORSCHE

2019

911

6 cyl. 3.8L Turbo				LF ⁴⁵⁰
-------------------	--	--	--	-------------------

718 Boxter

4 cyl. 2.5L Turbo				LF ⁴⁵⁰
-------------------	--	--	--	-------------------

718 Cayman

4 cyl. 2.5L Turbo				LF ⁴⁵⁰
-------------------	--	--	--	-------------------

2018

911

6 cyl. 3.8L Turbo				LF ⁴⁵⁰
-------------------	--	--	--	-------------------

718 Boxter

4 cyl. 2.5L Turbo				LF ⁴⁵⁰
-------------------	--	--	--	-------------------

718 Cayman

4 cyl. 2.5L Turbo				LF ⁴⁵⁰
-------------------	--	--	--	-------------------

Cayenne

V6 3.0L FI (S.C.) Hybrid	VO-92			NS ⁴³⁷
--------------------------	-------	--	--	-------------------

V6 3.6L Non turbo	VO-133	VA-204		NS ⁴³⁷
-------------------	--------	--------	--	-------------------

V6 3.6L Turbo		VA-204		NS ⁴³⁷
---------------	--	--------	--	-------------------

Macan

4 cyl. 2.0L Turbo	VO-117		VCA-1194	
-------------------	--------	--	----------	--

6 cyl. 3.0L Turbo			VCA-1194	
-------------------	--	--	----------	--

6 cyl. 3.6L Turbo			VCA-1194	
-------------------	--	--	----------	--

Se reporter à table de matière pour les notes en bas de page en français. Utilize el contenido para ver notas a pie.

NS - Non-Serviceable / Non réparable / No reparable LF - Life-Time Filter / Filtro para toda la vida / Filtre à vie

⁴³⁷ Requires replacement of the complete fuel pump/fuel filter module. ⁴⁵⁰ Lifetime filter. Does not require replacement under normal conditions.



PORSCHE (cont'd)

	Oil	Air	Cabin*	Fuel
2017				
718 Boxter				
4 cyl. 2.5L Turbo				LF ⁴⁵⁰
718 Cayman				
4 cyl. 2.5L Turbo				LF ⁴⁵⁰
Cayenne				
V6 3.0L FI (S.C.) Hybrid	VO-92			NS ⁴³⁷
V6 3.6L Non turbo	VO-133	VA-204		NS ⁴³⁷
V6 3.6L Turbo		VA-204		NS ⁴³⁷
Macan				
4 cyl. 2.0L Turbo	VO-117		VCA-1194	
6 cyl. 3.0L Turbo			VCA-1194	
6 cyl. 3.6L Turbo			VCA-1194	
2016				
911 Turbo				
6 cyl. 3.8L DI Turbo				LF ⁴⁵⁰
Cayenne				
V6 3.0L FI (S.C.) Hybrid	VO-92			NS ⁴³⁷
V6 3.6L Non turbo	VO-133	VA-204		NS ⁴³⁷
V6 3.6L Turbo		VA-204		NS ⁴³⁷
Macan				
6 cyl. 3.0L Turbo			VCA-1194	
6 cyl. 3.6L Turbo			VCA-1194	
2015				
911 Turbo				
6 cyl. 3.8L DI Turbo				LF ⁴⁵⁰
918 Spyder				
V8 4.6	VO-127			
Cayenne				
V6 3.0L FI (S.C.) Hybrid	VO-92			NS ⁴³⁷
V6 3.6L Non turbo	VO-133	VA-204		NS ⁴³⁷
V6 3.6L Turbo		VA-204		NS ⁴³⁷
Macan				
6 cyl. 3.0L Turbo			VCA-1194	
6 cyl. 3.6L Turbo			VCA-1194	
2014				
911 Turbo				
6 cyl. 3.8L DI Turbo				LF ⁴⁵⁰
Cayenne				
V6 3.0L FI (S.C.) Hybrid	VO-92			NS ⁴³⁷
V6 3.6L DI	VO-133	VA-204		NS ⁴³⁷
2013				
911 Turbo				
6 cyl. 3.8L DI Turbo				LF ⁴⁵⁰
Cayenne				
V6 3.0L FI (S.C.) Hybrid	VO-92			NS ⁴³⁷
V6 3.6L	VO-133	VA-204		NS ⁴³⁷
Panamera				
6 cyl. 3.0L FI (Hybrid)	VO-92			NS
2012				
Cayenne				
V6 3.0L FI (S.C.) Hybrid	VO-92			NS ⁴³⁷
V6 3.6L	VO-133	VA-204		NS ⁴³⁷

Se reporter à table de matière pour les notes en bas de page en français. Utilize el contenido para ver notas a pie.

NS - Non-Serviceable / Non réparable / No repairable LF - Life-Time Filter / Filtro para toda la vida / Filtre à vie

⁴³⁷ Requires replacement of the complete fuel pump/fuel filter module. ⁴⁵⁰ Lifetime filter. Does not require replacement under normal conditions.



PORSCHE (cont'd)

2012

Panamera

6 cyl. 3.0L FI (Hybrid)	VO-92			NS
-------------------------	-------	--	--	----

2011

Cayenne

V6 3.0L FI (S.C.) Hybrid	VO-92			NS ⁴³⁷
V6 3.6L DI	VO-150	VA-204		NS ⁴³⁷

2010

Cayenne

V6 3.6L DI	VO-150	VA-204		NS ⁴³⁷
------------	--------	--------	--	-------------------

2009

911

6 cyl. 3.6L FI	VO-127			NS ⁴³⁷
6 cyl. 3.8L FI	VO-127			NS ⁴³⁷

911 Turbo, 911 GT2

6 cyl. 3.6L FI Turbo	VO-127			
----------------------	--------	--	--	--

Cayenne

V6 3.6L DI	VO-150	VA-204		NS ⁴³⁷
------------	--------	--------	--	-------------------

2008

911

6 cyl. 3.6L FI Non Turbo	VO-127			NS ⁴³⁷
6 cyl. 3.8L FI	VO-127			NS ⁴³⁷

911 GT3

6 cyl. 3.6L FI	VO-127			
----------------	--------	--	--	--

911 Turbo, 911 GT2

6 cyl. 3.6L FI Turbo	VO-127			
----------------------	--------	--	--	--

Boxster

6 cyl. 2.7L FI	VO-127			
6 cyl. 3.4L FI	VO-127			

Cayenne

V6 3.6L DI	VO-150	VA-204		NS ⁴³⁷
V8 4.8L FI Non Turbo		VA-204 ¹¹²		NS ⁴³⁷

Cayman

6 cyl 2.7L FI	VO-127			
6 cyl 3.4L FI	VO-127			

2007

911

6 cyl. 3.6L FI Non Turbo	VO-127			NS ⁴³⁷
6 cyl. 3.8L FI	VO-127			NS ⁴³⁷

911 GT3

6 cyl. 3.6L FI	VO-127			
----------------	--------	--	--	--

911 Turbo, 911 GT2

6 cyl. 3.6L FI Turbo	VO-127			
----------------------	--------	--	--	--

Boxster

6 cyl. 2.7L FI	VO-127			
6 cyl. 3.4L FI	VO-127			

Cayman

6 cyl 2.7L FI	VO-127			
6 cyl 3.4L FI	VO-127			

2006

911

6 cyl. 3.6L FI	VO-127			NS ⁴³⁷
6 cyl. 3.8L FI	VO-127			NS ⁴³⁷

Se reporter à table de matière pour les notes en bas de page en français. Utilize el contenido para ver notas a pie.

NS - Non-Serviceable / Non réparable / No repairable LF - Life-Time Filter / Filtro para toda la vida / Filtre à vie

¹¹² Requires two (2). ⁴³⁷ Requires replacement of the complete fuel pump/fuel filter module.



PORSCHE (cont'd)

	Oil	Air	Cabin*	Fuel
2006				
911 Turbo, 911 GT2				
6 cyl. 3.6L FI Turbo	VO-127			
Boxster				
6 cyl. 2.7L FI	VO-127			
6 cyl. 3.2L FI	VO-127			
Cayenne				
V6 3.2L FI	VO-150	VA-204		
V8 4.5L FI Non Turbo	VO-127	VA-204		
V8 4.5L FI Turbo	VO-127			
Cayman				
6 cyl. 3.4L FI	VO-127			
2005				
911				
6 cyl. 3.6L FI	VO-127			
6 cyl. 3.8L FI	VO-127			
911 GT3				
6 cyl. 3.6L FI	VO-127			
911 Turbo, 911 GT2				
6 cyl. 3.6L FI Turbo	VO-127			
Boxster				
6 cyl. 2.7L FI	VO-127			
6 cyl. 3.2L FI	VO-127			
Carrera GT				
V10 5.7L FI	VO-127			
Cayenne				
V6 3.2L FI	VO-150	VA-204		
V8 4.5L FI Non Turbo	VO-127	VA-204		
V8 4.5L FI Turbo	VO-127			
2004				
911 Carrera				
6 cyl. 3.6L FI Non Turbo	VO-127			
911 GT3				
6 cyl. 3.6L FI	VO-127			
911 Turbo, 911 GT2				
6 cyl. 3.6L FI Turbo	VO-127			
Boxster				
6 cyl. 2.7L FI	VO-127			
6 cyl. 3.2L FI	VO-127			
Carrera GT				
V10 5.7L FI	VO-127			
Cayenne				
V6 3.2L FI	VO-150	VA-204		
V8 4.5L FI Non Turbo	VO-127	VA-204		
V8 4.5L FI Turbo	VO-127			
2003				
911 Carrera				
6 cyl. 3.6L FI	VO-127			
911 Turbo, 911 GT2				
6 cyl. 3.6L FI Turbo	VO-127			
Boxster				
6 cyl. 2.7L FI	VO-127			
6 cyl. 3.2L FI	VO-127			

Se reporter à table de matière pour les notes en bas de page en français. Utilize el contenido para ver notas a pie.

NS - Non-Serviceable / Non réparable / No repairable LF - Life-Time Filter / Filtro para toda la vida / Filtre à vie



PORSCHE (cont'd)

2003

Cayenne

V8 4.5L FI Non Turbo	VO-127	VA-204		
V8 4.5L FI Turbo	VO-127			

2002

911 Carrera

6 cyl. 3.6L FI	VO-127			
----------------	--------	--	--	--

911 Turbo, 911 GT2

6 cyl. 3.6L FI Turbo	VO-127			
----------------------	--------	--	--	--

Boxster

6 cyl. 2.7L FI	VO-127			
6 cyl. 3.2L FI	VO-127			

2001

911

6 cyl. 3.4L FI	VO-127			
6 cyl. 3.6L FI Turbo	VO-127			

Boxster

6 cyl. 2.7L FI	VO-127			
6 cyl. 3.2L FI	VO-127			

2000

911

6 cyl. 3.4L FI DOHC	VO-127			
---------------------	--------	--	--	--

Boxster

6 cyl. 2.7L FI	VO-127			
6 cyl. 3.2L FI	VO-127			

1999

911

6 cyl. 3.4L FI	VO-127			
----------------	--------	--	--	--

Boxster

6 cyl. 2.5L FI	VO-127			
----------------	--------	--	--	--

1998

Boxster

6 cyl. 2.5L FI	VO-127			
----------------	--------	--	--	--

1997

Boxster

6 cyl. 2.5L FI	VO-127			
----------------	--------	--	--	--

1995

968

4 cyl. 3.0L FI	VO-135			
----------------	--------	--	--	--

RAM

2019

ProMaster 1500, 2500, 3500

V6 3.6L	VO-114		VCA-1193	
---------	--------	--	----------	--

ProMaster City

4 cyl. 2.4L	VO-88	VA-455		NS ⁴³⁷
-------------	-------	--------	--	-------------------

1500

V6 3.6L	VO-114	VA-504	VCA-1064 ⁸⁸⁰	NS ⁴³⁷
V8 5.7L	VO-88	VA-504	VCA-1064 ⁸⁸⁰	NS ⁴³⁷

1500 Classic

V6 3.0L Diesel Turbo	VO-142	VA-460	VCA-1064 ⁸⁸⁰	
V6 3.6L	VO-114	VA-160	VCA-1064 ⁸⁸⁰	NS ⁴³⁷
V8 5.7L	VO-88	VA-160	VCA-1064 ⁸⁸⁰	NS ⁴³⁷

Se reporter à table de matière pour les notes en bas de page en français. Utilize el contenido para ver notas a pie.

NS - Non-Serviceable / Non réparable / No reparable LF - Life-Time Filter / Filtro para toda la vida / Filtre à vie

⁴³⁷ Requires replacement of the complete fuel pump/fuel filter module. ⁸⁸⁰ If equipped with cabin air filter



RAM (cont'd)

	Oil	Air	Cabin*	Fuel
2019				
2500, 3500				
V8 5.7L	VO-88	VA-160	VCA-1064 ⁸⁸⁰	NS ⁴³⁷
V8 6.4L	VO-88	VA-160	VCA-1064 ⁸⁸⁰	NS ⁴³⁷
6 cyl 6.7L Diesel Turbo	VO-64	VA-264	VCA-1064 ⁸⁸⁰	
2018				
ProMaster 1500, 2500, 3500				
4 cyl. 3.0 Diesel Turbo	VO-170		VCA-1193	
V6 3.6L	VO-114		VCA-1193	
ProMaster City				
4 cyl. 2.4L	VO-88	VA-455		NS ⁴³⁷
1500, 2500, 3500				
V6 3.0L Diesel Turbo	VO-142	VA-460	VCA-1064 ⁸⁸⁰	
V6 3.6L	VO-114	VA-160	VCA-1064 ⁸⁸⁰	NS ⁴³⁷
V8 5.7L	VO-88	VA-160	VCA-1064 ⁸⁸⁰	NS ⁴³⁷
V8 6.4L	VO-88	VA-460	VCA-1064 ⁸⁸⁰	NS ⁴³⁷
6 cyl 6.7L Diesel Turbo	VO-64	VA-264	VCA-1064 ⁸⁸⁰	
4500, 5500				
V8 6.4L	VO-88	VA-460	VCA-1064 ⁸⁸⁰	NS ⁴³⁷
6 cyl 6.7L Diesel Turbo	VO-64	VA-264	VCA-1064 ⁸⁸⁰	
2017				
ProMaster 1500, 2500, 3500				
4 cyl. 3.0 Diesel Turbo	VO-170		VCA-1193	
V6 3.6L	VO-114		VCA-1193	
ProMaster City				
4 cyl. 2.4L	VO-88	VA-455		NS ⁴³⁷
1500, 2500, 3500				
V6 3.0L Diesel Turbo	VO-142	VA-460	VCA-1064 ⁸⁸⁰	
V6 3.6L	VO-114	VA-160	VCA-1064 ⁸⁸⁰	NS ⁴³⁷
V8 5.7L	VO-88	VA-160	VCA-1064 ⁸⁸⁰	NS ⁴³⁷
V8 6.4L	VO-88	VA-460	VCA-1064 ⁸⁸⁰	NS ⁴³⁷
6 cyl 6.7L Diesel Turbo	VO-64	VA-264	VCA-1064 ⁸⁸⁰	
4500, 5500				
V8 6.4L	VO-88	VA-460	VCA-1064 ⁸⁸⁰	NS ⁴³⁷
6 cyl 6.7L Diesel Turbo	VO-64	VA-264	VCA-1064 ⁸⁸⁰	
2016				
ProMaster 1500, 2500, 3500				
4 cyl. 3.0 Diesel Turbo	VO-170		VCA-1193	
V6 3.6L	VO-114		VCA-1193	
ProMaster City				
4 cyl. 2.4L	VO-88	VA-455		NS ⁴³⁷
1500, 2500, 3500				
V6 3.0L Diesel Turbo	VO-142	VA-460	VCA-1064 ⁸⁸⁰	
V6 3.6L FI (Flex Fuel)	VO-114	VA-160	VCA-1064 ⁸⁸⁰	NS ⁴³⁷
V8 5.7L	VO-88	VA-160	VCA-1064 ⁸⁸⁰	NS ⁴³⁷
V8 6.4L	VO-88	VA-460	VCA-1064 ⁸⁸⁰	NS ⁴³⁷
6 cyl 6.7L Diesel Turbo	VO-64	VA-264	VCA-1064 ⁸⁸⁰	
4500, 5500				
V8 6.4L	VO-88	VA-460	VCA-1064 ⁸⁸⁰	NS ⁴³⁷
6 cyl 6.7L Diesel Turbo	VO-64	VA-264	VCA-1064 ⁸⁸⁰	
2015				
Cargo Van				
V6 3.6L (G) FI (Flex Fuel)	VO-114	VA-286	VCA-1044	NS ⁴³⁷

Se reporter à table de matière pour les notes en bas de page en français. Utilize el contenido para ver notas a pie.

NS - Non-Serviceable / Non réparable / No reparable LF - Life-Time Filter / Filtro para toda la vida / Filtre à vie

⁴³⁷ Requires replacement of the complete fuel pump/fuel filter module. ⁸⁸⁰ If equipped with cabin air filter



RAM (cont'd)

2015

ProMaster 1500, 2500, 3500

4 cyl. 3.0 Diesel Turbo	VO-170		VCA-1193	
V6 3.6L	VO-114		VCA-1193	

ProMaster City

4 cyl. 2.4L	VO-88	VA-455		NS ⁴³⁷
-------------	-------	--------	--	-------------------

1500, 2500, 3500

V6 3.0L Diesel Turbo	VO-142	VA-460		
V6 3.6L FI (Flex Fuel)	VO-114	VA-160		NS ⁴³⁷
V8 5.7L FI	VO-88	VA-160		NS ⁴³⁷
V8 6.4L FI	VO-88	VA-460		NS ⁴³⁷
6 cyl 6.7L Diesel Turbo	VO-64	VA-264		

4500, 5500

V8 6.4L FI	VO-88	VA-460		NS ⁴³⁷
6 cyl 6.7L Diesel Turbo	VO-64	VA-264		

2014

Cargo Van

V6 3.6L (G) FI (Flex Fuel)	VO-114	VA-286	VCA-1044	NS ⁴³⁷
----------------------------	--------	--------	----------	-------------------

ProMaster 1500, 2500, 3500

4 cyl. 3.0 Diesel Turbo	VO-170		VCA-1193	
V6 3.6L	VO-114		VCA-1193	

1500, 2500, 3500

V6 3.0L Diesel Turbo	VO-142	VA-460		
V6 3.6L FI (Flex Fuel)	VO-114	VA-160		NS ⁴³⁷
V8 5.7L FI	VO-88	VA-160		NS ⁴³⁷
V8 6.4L FI	VO-88	VA-460		NS ⁴³⁷
6 cyl 6.7L Diesel Turbo	VO-64	VA-264		

4500, 5500

V8 6.4L FI	VO-88	VA-460		NS ⁴³⁷
6 cyl 6.7L Diesel Turbo	VO-64	VA-264		

2013

Cargo Van

V6 3.6L (G) FI (Flex Fuel)	VO-110	VA-286	VCA-1044	NS ⁴³⁷
----------------------------	--------	--------	----------	-------------------

1500, 2500, 3500

V6 3.6L FI (Flex Fuel)	VO-110	VA-160		NS ⁴³⁷
V8 4.7L FI (Flex Fuel)	VO-88	VA-160		NS ⁴³⁷
V8 5.7L FI	VO-88	VA-160		NS ⁴³⁷
6 cyl 6.7L Diesel Turbo	VO-64	VA-264		

4500, 5500

6 cyl 6.7L Diesel Turbo	VO-64	VA-264		
-------------------------	-------	--------	--	--

2012

Cargo Van

V6 3.6L (G) FI (Flex Fuel)	VO-110	VA-286	VCA-1044	NS ⁴³⁷
----------------------------	--------	--------	----------	-------------------

1500, 2500, 3500

V6 3.7L	VO-88	VA-160		NS ⁴³⁷
V8 4.7L (Flex Fuel)	VO-88	VA-160		NS ⁴³⁷
V8 5.7L (T)	VO-88	VA-160		NS ⁴³⁷
V8 5.7L (2) FI (Bi-Fuel)	VO-88	VA-160		NS ⁴³⁷
6 cyl 6.7L Diesel Turbo	VO-64	VA-264		

4500, 5500

6 cyl 6.7L (L) Diesel Turbo	VO-64	VA-264		
-----------------------------	-------	--------	--	--

Se reporter à table de matière pour les notes en bas de page en français. Utilize el contenido para ver notas a pie.

NS - Non-Serviceable / Non réparable / No reparable LF - Life-Time Filter / Filtro para toda la vida / Filtre à vie

⁴³⁷ Requires replacement of the complete fuel pump/fuel filter module.



RAM (cont'd)

2011				
Dakota				
V6 3.7L (K) FI	VO-88	VA-90		NS ⁴³⁷
V8 4.7L (P) FI (Flex Fuel)	VO-88	VA-90		NS ⁴³⁷
1500, 2500, 3500				
V6 3.7L (K) FI	VO-88	VA-160		NS ⁴³⁷
V8 4.7L (P) FI (Flex Fuel)	VO-88	VA-160		NS ⁴³⁷
V8 5.7L (T) FI	VO-88	VA-160		NS ⁴³⁷
6 cyl 6.7L (L) Diesel Turbo	VO-64	VA-264		
4500, 5500				
6 cyl 6.7L (L) Diesel Turbo	VO-64	VA-264		

SAAB

2011				
9-3, 9-3X				
4 cyl. 2.0L FI Turbo	VO-76			NS ⁴³⁷
9-4X				
V6 2.8L DI	VO-67	VA-296	VCA-1078C ^{X401} VCA-1078 ^{Z401}	
V6 3.0L DI	VO-88	VA-296	VCA-1078C ^{X401} VCA-1078 ^{Z401}	
9-5				
4 cyl. 2.0L FI Turbo	VO-76	VA-254	VCA-1078C ^{X401} VCA-1078 ^{Z401}	NS ⁴³⁷
V6 2.8L FI Turbo	VO-67	VA-254	VCA-1078C ^{X401} VCA-1078 ^{Z401}	NS ⁴³⁷
2010				
9-3, 9-3X				
4 cyl. 2.0L FI Turbo	VO-76			NS ⁴³⁷
9-5				
V6 2.8L FI Turbo	VO-67	VA-254	VCA-1078C ^{X401} VCA-1078 ^{Z401}	NS ⁴³⁷
2009				
9-3				
4 cyl. 2.0L FI Turbo	VO-76			NS ⁴³⁷
V6 2.8L FI Turbo	VO-67			NS ⁴³⁷
9-5				
4 cyl. 2.3L FI Turbo	VO-25			NS ⁴³⁷
9-7X				
6 cyl 4.2L FI	VO-108	VA-161		NS ⁴³⁷
V8 5.3L FI	VO-88	VA-161		NS ⁴³⁷
V8 6.0L FI	VO-88	VA-161		NS ⁴³⁷
2008				
9-3				
4 cyl. 2.0L FI Turbo	VO-76			NS ⁴³⁷
V6 2.8L FI Turbo	VO-67			NS ⁴³⁷
9-5				
4 cyl. 2.3L FI Turbo	VO-25			NS ⁴³⁷
9-7X				
6 cyl 4.2L FI	VO-108	VA-161		NS ⁴³⁷
V8 5.3L FI	VO-88	VA-161		NS ⁴³⁷
V8 6.0L FI	VO-88	VA-161		NS ⁴³⁷

Se reporter à table de matière pour les notes en bas de page en français. Utilize el contenido para ver notas a pie.

NS - Non-Serviceable / Non réparable / No repairable LF - Life-Time Filter / Filtro para toda la vida / Filtre à vie

⁴³⁷ Requires replacement of the complete fuel pump/fuel filter module. ^{X401}Dust and Odor filter ^{Z401}Dust filter



SAAB (cont'd)

2007

9-3

4 cyl. 2.0L FI Turbo	VO-76			NS ⁴³⁷
V6 2.8L FI Turbo	VO-67			NS ⁴³⁷

9-5

4 cyl. 2.3L FI Turbo	VO-25			NS ⁴³⁷
----------------------	-------	--	--	-------------------

9-7X

6 cyl 4.2L FI	VO-108	VA-161		NS ⁴³⁷
V8 5.3L FI	VO-88	VA-161		NS ⁴³⁷

2006

9-2X

4 cyl. 2.5L FI	VO-113	VA-86		
----------------	--------	-------	--	--

9-3

4 cyl. 2.0L FI Turbo	VO-76			NS ⁴³⁷
V6 2.8L FI Turbo	VO-67			NS ⁴³⁷

9-5

4 cyl. 2.3L FI Turbo	VO-25			
----------------------	-------	--	--	--

9-7X

6 cyl 4.2L FI	VO-108	VA-161		NS ⁴³⁷
V8 5.3L FI	VO-58	VA-161		NS ⁴³⁷

2005

9-2X

4 cyl. 2.0L FI Turbo	VO-113	VA-86		
4 cyl. 2.5L FI	VO-113	VA-86		

9-3

4 cyl. 2.0L FI Turbo	VO-76			NS ⁴³⁷
----------------------	-------	--	--	-------------------

9-5

4 cyl. 2.3L FI Turbo	VO-25			
----------------------	-------	--	--	--

9-7X

6 cyl 4.2L FI	VO-108	VA-161		
V8 5.3L FI	VO-58	VA-161		

2004

9-3

4 cyl. 2.0L FI Turbo	VO-76			NS ⁴³⁷
----------------------	-------	--	--	-------------------

9-5

4 cyl. 2.3L FI Turbo	VO-25			
----------------------	-------	--	--	--

2003

9-3 Hatchback/Convertible

4 cyl. 2.0L FI Turbo	VO-25			
----------------------	-------	--	--	--

9-3 Sedan

4 cyl. 2.0L FI Turbo	VO-76			NS ⁴³⁷
----------------------	-------	--	--	-------------------

9-5

4 cyl. 2.3L FI Turbo	VO-25			
V6 3.0L FI Turbo	VO-25			

2002

9-3

4 cyl. 2.0L FI Turbo	VO-25			
4 cyl. 2.3L FI Turbo	VO-25			

9-5

4 cyl. 2.3L FI Turbo	VO-25			
V6 3.0L FI Turbo	VO-25			

Se reporter à table de matière pour les notes en bas de page en français. Utilize el contenido para ver notas a pie.

NS - Non-Serviceable / Non réparable / No reparable LF - Life-Time Filter / Filtro para toda la vida / Filtre à vie

⁴³⁷ Requires replacement of the complete fuel pump/fuel filter module.



SAAB (cont'd)

	Oil	Air	Cabin*	Fuel
2001				
9-3				
4 cyl. 2.0L FI Turbo	VO-25			
4 cyl. 2.3L FI Turbo	VO-25			
9-3 SE				
4 cyl. 2.0L FI Turbo	VO-25			
9-5				
4 cyl. 2.3L FI Turbo	VO-25			
V6 3.0L FI Turbo	VO-25			
2000				
9-3				
4 cyl. 2.0L FI Turbo	VO-25			
4 cyl. 2.3L FI Turbo	VO-25			
9-5				
4 cyl. 2.3L FI Turbo	VO-25			
V6 3.0L FI Turbo	VO-25			
1999				
9-3				
4 cyl. 2.0L FI Turbo	VO-25			
4 cyl. 2.3L FI Turbo	VO-25			
9-5				
4 cyl. 2.3L FI Turbo	VO-25			
V6 3.0L FI Turbo	VO-25			
1998				
900				
4 cyl. 2.0L FI Turbo	VO-25			
4 cyl. 2.3L FI	VO-25			
9000				
4 cyl. 2.3L FI Turbo	VO-25			
1997				
900				
4 cyl. 2.0L FI Turbo	VO-25			
4 cyl. 2.3L FI	VO-25			
V6 2.5L FI	VO-16			
9000				
4 cyl. 2.3L FI Turbo	VO-25			
V6 3.0L FI	VO-16			
1996				
900				
4 cyl. 2.0L FI Turbo	VO-25			
4 cyl. 2.3L FI	VO-25			
V6 2.5L FI	VO-16			
9000				
4 cyl. 2.3L FI Turbo	VO-25			
V6 3.0L FI	VO-16			
1995				
900				
4 cyl. 2.0L FI Turbo	VO-25			
4 cyl. 2.3L FI	VO-25			
V6 2.5L FI	VO-16			
9000				
4 cyl. 2.3L FI Turbo	VO-25			
V6 3.0L FI	VO-16			

Se reporter à table de matière pour les notes en bas de page en français. Utilize el contenido para ver notas a pie.

NS - Non-Serviceable / Non réparable / No reparable LF - Life-Time Filter / Filtro para toda la vida / Filtre à vie



SAAB (cont'd)

1994

900

4 cyl. 2.0L FI Turbo	VO-25			
4 cyl. 2.3L FI	VO-25			
V6 2.5L FI	VO-16			

SATURN

2010

Aura

4 cyl 2.4L (B) FI	VO-76	VA-176		NS ⁴³⁷
-------------------	-------	--------	--	-------------------

Outlook

V6 3.6L	VO-88	VA-225	VCA-1080	NS ⁴³⁷
---------	-------	--------	----------	-------------------

Sky

4 cyl. 2.0L (X) FI Turbo	VO-76	VA-360		NS ⁴³⁷
4 cyl. 2.4L (B) FI	VO-76	VA-360		NS ⁴³⁷

VUE

4 cyl 2.4L (P,1) FI	VO-76	VA-236	VCA-1075	NS ⁴³⁷
V6 3.6L (7) FI	VO-88	VA-236	VCA-1075	NS ⁴³⁷

2009

Astra

4 cyl 1.8L (1) FI	VO-98			NS ⁴³⁷
-------------------	-------	--	--	-------------------

Aura

4 cyl 2.4L (B) FI	VO-76	VA-176		NS ⁴³⁷
4 cyl 2.4L (5) FI (Hybrid)	VO-76	VA-176		NS ⁴³⁷
V6 3.6L (7) FI	VO-88	VA-176		NS ⁴³⁷

Outlook

V6 3.6L	VO-88	VA-225	VCA-1080	NS ⁴³⁷
---------	-------	--------	----------	-------------------

Sky

4 cyl. 2.0L (X) FI Turbo	VO-76	VA-360		NS ⁴³⁷
4 cyl. 2.4L (B) FI	VO-76	VA-360		NS ⁴³⁷

VUE

4 cyl 2.4L (P) FI	VO-76	VA-236	VCA-1075	NS ⁴³⁷
4 cyl 2.4L (Z) FI (Hybrid)	VO-76	VA-236	VCA-1075	NS ⁴³⁷
V6 3.5L (N) FI	VO-108	VA-236	VCA-1075	NS ⁴³⁷
V6 3.6L (7) FI	VO-88	VA-236	VCA-1075	NS ⁴³⁷

2008

Astra

4 cyl 1.8L (1) FI	VO-98			NS ⁴³⁷
-------------------	-------	--	--	-------------------

Aura

4 cyl 2.4L (B) FI	VO-76	VA-176		NS ⁴³⁷
4 cyl 2.4L (5) FI (Hybrid)	VO-76	VA-176		NS ⁴³⁷
V6 3.5L (N) FI	VO-108	VA-176		NS ⁴³⁷
V6 3.6L (7) FI	VO-88	VA-176		NS ⁴³⁷

Outlook

V6 3.6L	VO-88	VA-225	VCA-1080	NS ⁴³⁷
---------	-------	--------	----------	-------------------

Sky

4 cyl. 2.0L (X) FI Turbo	VO-76	VA-360		NS ⁴³⁷
4 cyl. 2.4L (B) FI	VO-76	VA-360		NS ⁴³⁷

VUE

4 cyl 2.4L (B,P) FI	VO-76	VA-236	VCA-1075	NS ⁴³⁷
4 cyl 2.4L (Z) FI (Hybrid)	VO-76	VA-236	VCA-1075	NS ⁴³⁷
V6 3.5L (N) FI	VO-108	VA-236	VCA-1075	NS ⁴³⁷
V6 3.6L (7) FI	VO-88	VA-236	VCA-1075	NS ⁴³⁷

Se reporter à table de matière pour les notes en bas de page en français. Utilize el contenido para ver notas a pie.

NS - Non-Serviceable / Non réparable / No reparable LF - Life-Time Filter / Filtro para toda la vida / Filtre à vie

⁴³⁷ Requires replacement of the complete fuel pump/fuel filter module.



SATURN (cont'd)

	Oil	Air	Cabin*	Fuel
2007				
Aura				
4 cyl. 2.4L (5) FI (Hybrid)	VO-76	VA-176		NS ⁴³⁷
V6 3.5L (N) FI	VO-108	VA-176		NS ⁴³⁷
V6 3.6L (7) FI	VO-88	VA-176		NS ⁴³⁷
ION				
4 cyl. 2.0L (P) FI (S.C.)	VO-76	VA-161	VCA-1065	
4 cyl. 2.2L (F) FI	VO-76	VA-211	VCA-1065	
4 cyl. 2.4L (B) FI	VO-76	VA-211	VCA-1065	
Outlook				
V6 3.6L	VO-88	VA-225	VCA-1080	NS ⁴³⁷
Relay				
V6 3.9L (1) FI	VO-108	VA-109	VCA-1164	NS ⁴³⁷
V6 3.9L (W) FI (Flex Fuel)	VO-108	VA-109	VCA-1164	NS ⁴³⁷
Sky				
4 cyl. 2.0L (X) FI Turbo	VO-76	VA-360		NS ⁴³⁷
4 cyl. 2.4L (B) FI	VO-76	VA-360		NS ⁴³⁷
VUE				
4 cyl. 2.2L (D) FI	VO-76	VA-176	VCA-1030	NS ⁴³⁷
4 cyl. 2.4L (Z) FI (Hybrid)	VO-76	VA-176	VCA-1030	NS ⁴³⁷
V6 3.5L (4) FI	VO-106	VA-176	VCA-1030	NS ⁴³⁷
2006				
ION				
4 cyl. 2.0L (P) FI (S.C.)	VO-76	VA-161	VCA-1065	
4 cyl. 2.2L (F) FI	VO-76	VA-211	VCA-1065	
4 cyl. 2.4L (B) FI	VO-76	VA-211	VCA-1065	
Relay				
V6 3.5L (L) FI	VO-16	VA-109	VCA-1164	NS ⁴³⁷
V6 3.9L (1) FI	VO-108	VA-109	VCA-1164	NS ⁴³⁷
VUE				
4 cyl. 2.2L FI	VO-76	VA-176	VCA-1030	NS ⁴³⁷
V6 3.5L FI	VO-106	VA-176	VCA-1030	NS ⁴³⁷
2005				
ION				
4 cyl. 2.0L (P) FI (S.C.)	VO-76	VA-161	VCA-1065	
4 cyl. 2.2L (F) FI	VO-76	VA-175	VCA-1065	
L300, LW300				
V6 3.0L FI	VO-73	VA-151	VCA-1029	VG-30
Relay				
V6 3.5L (L) FI	VO-16	VA-109	VCA-1164	NS ⁴³⁷
VUE				
4 cyl. 2.2L FI	VO-76	VA-176	VCA-1030	NS ⁴³⁷
V6 3.5L FI	VO-106	VA-176	VCA-1030	NS ⁴³⁷
2004				
ION				
4 cyl. 2.0L (P) FI (S.C.)	VO-76	VA-161	VCA-1065	
4 cyl. 2.2L (F) FI	VO-76	VA-175	VCA-1065	
L300, LW300				
4 cyl. 2.2L FI	VO-76	VA-151	VCA-1029	VG-30
V6 3.0L FI	VO-73	VA-151	VCA-1029	VG-30
VUE				
4 cyl. 2.2L FI	VO-76	VA-176	VCA-1030	NS ⁴³⁷
V6 3.5L FI	VO-106	VA-176	VCA-1030	NS ⁴³⁷

Se reporter à table de matière pour les notes en bas de page en français. Utilize el contenido para ver notas a pie.

NS - Non-Serviceable / Non réparable / No reparable LF - Life-Time Filter / Filtro para toda la vida / Filtre à vie

⁴³⁷ Requires replacement of the complete fuel pump/fuel filter module.



SATURN (cont'd)

2003

ION

4 cyl. 2.2L (F) FI	VO-76	VA-175	VCA-1065	
L200, LW200				
4 cyl. 2.2L FI	VO-76	VA-151	VCA-1029	VG-30
L300, LW300				
V6 3.0L FI	VO-73	VA-151	VCA-1029	VG-30
VUE				
4 cyl. 2.2L FI	VO-76	VA-176	VCA-1030	
V6 3.0L FI	VO-73	VA-176	VCA-1030	

2002

L100, L200, LW200

4 cyl. 2.2L FI	VO-76	VA-151	VCA-1029	VG-30
L300, LW300				
V6 3.0L FI	VO-73	VA-151	VCA-1029	VG-30
SC1-SL-SL1				
4 cyl. 1.9L (8) FI SOHC	VO-25	VA-101		
SC2-SL2				
4 cyl. 1.9L (7) FI DOHC	VO-25	VA-101		
VUE				
4 cyl. 2.2L FI	VO-76	VA-176	VCA-1030	
V6 3.0L FI	VO-73	VA-176	VCA-1030	

2001

L100, L200, LW200

4 cyl. 2.2L FI	VO-76	VA-151	VCA-1029	VG-30
L300, LW300				
V6 3.0L FI	VO-73	VA-151	VCA-1029	VG-30
SC1-SL1-SW1				
4 cyl. 1.9L (8) FI SOHC	VO-25	VA-101		
SC2-SL2-SW2				
4 cyl. 1.9L (7) FI DOHC	VO-25	VA-101		

2000

LS-LS1-LW1

4 cyl. 2.2L FI	VO-76	VA-151	VCA-1029	VG-30
LS2-LW2				
V6 3.0L FI	VO-73	VA-151	VCA-1029	VG-30
SC1-SL1-SW1				
4 cyl. 1.9L (8) FI SOHC	VO-25	VA-101		
SC2-SL2-SW2				
4 cyl. 1.9L (7) FI DOHC	VO-25	VA-101		

1999

SC1-SL1-SW1

4 cyl. 1.9L (8) FI SOHC	VO-25	VA-101		
SC2-SL2-SW2				
4 cyl. 1.9L (7) FI DOHC	VO-25	VA-101		

1998

SC1-SL1-SW1

4 cyl. 1.9L (8) FI SOHC	VO-25	VA-101		
SC2-SL2-SW2				
4 cyl. 1.9L (7) FI DOHC	VO-25	VA-101		

Se reporter à table de matière pour les notes en bas de page en français. Utilize el contenido para ver notas a pie.
 NS - Non-Serviceable / Non réparable / No reparable LF - Life-Time Filter / Filtro para toda la vida / Filtre à vie



SATURN (cont'd)

1997				
SC1-SL1-SW1				
4 cyl. 1.9L (8) FI SOHC	VO-25	VA-101		
SC2-SL2-SW2				
4 cyl. 1.9L (7) FI DOHC	VO-25	VA-101		
1996				
SC1-SL1-SW1				
4 cyl. 1.9L (8) FI SOHC	VO-25	VA-101		
SC2-SL2-SW2				
4 cyl. 1.9L (7) FI DOHC	VO-25	VA-101		
1995				
SC1-SL1-SW1				
4 cyl. 1.9L (8) FI SOHC	VO-25	VA-101		
SC2-SL2-SW2				
4 cyl. 1.9L (7) FI DOHC	VO-25	VA-101		

SCION

2016				
FR-S				
4 cyl. 2.0L	VO-113	VA-171	VCA-1110	NS ⁴³⁷
iA				
L4 1.5	VO-106			
iM				
L4 1.8	VO-102	VA-231	VCA-1031	
tC				
4 cyl. 2.5L	VO-84	VA-209	VCA-1031	NS ⁴³⁷
2015				
FR-S				
4 cyl. 2.0L	VO-113	VA-171	VCA-1110	NS ⁴³⁷
iQ				
4 cyl. 1.3L	VO-121			NS ⁴³⁷
tC				
4 cyl. 2.5L	VO-84	VA-209	VCA-1031	NS ⁴³⁷
xB				
4 cyl. 2.4L	VO-40	VA-209	VCA-1031	NS ⁴³⁷
2014				
FR-S				
4 cyl. 2.0L	VO-113	VA-171	VCA-1110	NS ⁴³⁷
iQ				
4 cyl. 1.3L	VO-121			NS ⁴³⁷
tC				
4 cyl. 2.5L	VO-84	VA-209	VCA-1031	NS ⁴³⁷
xB				
4 cyl. 2.4L	VO-40	VA-209	VCA-1031	NS ⁴³⁷
xD				
4 cyl. 1.8L	VO-102	VA-231	VCA-1031	NS ⁴³⁷
2013				
FR-S				
4 cyl. 2.0L	VO-113	VA-171	VCA-1110	NS ⁴³⁷
iQ				
4 cyl. 1.3L	VO-121			NS ⁴³⁷
tC				
4 cyl. 2.5L	VO-84	VA-209	VCA-1031	NS ⁴³⁷

Se reporter à table de matière pour les notes en bas de page en français. Utilize el contenido para ver notas a pie.

NS - Non-Serviceable / Non réparable / No reparable LF - Life-Time Filter / Filtro para toda la vida / Filtre à vie

⁴³⁷ Requires replacement of the complete fuel pump/fuel filter module.



SCION (cont'd)

2013

xB

4 cyl. 2.4L	VO-40	VA-209	VCA-1031	NS ⁴³⁷
-------------	-------	--------	----------	-------------------

xD

4 cyl 1.8L	VO-102	VA-231	VCA-1031	NS ⁴³⁷
------------	--------	--------	----------	-------------------

2012

iQ

4 cyl. 1.3L	VO-121			NS ⁴³⁷
-------------	--------	--	--	-------------------

tC

4 cyl. 2.5L	VO-84	VA-209	VCA-1031	NS ⁴³⁷
-------------	-------	--------	----------	-------------------

xB

4 cyl. 2.4L	VO-40	VA-209	VCA-1031	NS ⁴³⁷
-------------	-------	--------	----------	-------------------

xD

4 cyl 1.8L	VO-102	VA-231	VCA-1031	NS ⁴³⁷
------------	--------	--------	----------	-------------------

2011

tC

4 cyl. 2.5L	VO-84	VA-209	VCA-1031	NS ⁴³⁷
-------------	-------	--------	----------	-------------------

xB

4 cyl. 2.4L	VO-40	VA-209	VCA-1031	NS ⁴³⁷
-------------	-------	--------	----------	-------------------

xD

4 cyl 1.8L	VO-102	VA-231	VCA-1031	NS ⁴³⁷
------------	--------	--------	----------	-------------------

2010

tC

4 cyl. 2.4L	VO-40	VA-171	VCA-1042	NS ⁴³⁷
-------------	-------	--------	----------	-------------------

xB

4 cyl. 2.4L	VO-40	VA-209	VCA-1031	NS ⁴³⁷
-------------	-------	--------	----------	-------------------

xD

4 cyl 1.8L	VO-102	VA-231	VCA-1031	NS ⁴³⁷
------------	--------	--------	----------	-------------------

2009

tC

4 cyl. 2.4L	VO-40	VA-171	VCA-1042	NS ⁴³⁷
-------------	-------	--------	----------	-------------------

xB

4 cyl. 2.4L	VO-40	VA-209	VCA-1031	NS ⁴³⁷
-------------	-------	--------	----------	-------------------

xD

4 cyl 1.8L	VO-102	VA-231	VCA-1031	NS ⁴³⁷
------------	--------	--------	----------	-------------------

2008

tC

4 cyl. 2.4L	VO-40	VA-171	VCA-1042	NS ⁴³⁷
-------------	-------	--------	----------	-------------------

xB

4 cyl. 2.4L	VO-40	VA-209	VCA-1031	NS ⁴³⁷
-------------	-------	--------	----------	-------------------

xD

4 cyl 1.8L	VO-102	VA-231	VCA-1031	NS ⁴³⁷
------------	--------	--------	----------	-------------------

2007

tC

4 cyl. 2.4L	VO-40	VA-171	VCA-1042	NS ⁴³⁷
-------------	-------	--------	----------	-------------------

2006

tC

4 cyl. 2.4L	VO-40	VA-171	VCA-1042	NS ⁴³⁷
-------------	-------	--------	----------	-------------------

xA

4 cyl. 1.5L	VO-40	VA-191	VCA-1042	NS ⁴³⁷
-------------	-------	--------	----------	-------------------

xB

4 cyl. 1.5L	VO-40	VA-191	VCA-1042	NS ⁴³⁷
-------------	-------	--------	----------	-------------------

Se reporter à table de matière pour les notes en bas de page en français. Utilize el contenido para ver notas a pie.

NS - Non-Serviceable / Non réparable / No reparable LF - Life-Time Filter / Filtro para toda la vida / Filtre à vie

⁴³⁷ Requires replacement of the complete fuel pump/fuel filter module.



SCION (cont'd)

2005				
tC				
4 cyl. 2.4L	VO-40	VA-171	VCA-1042	NS ⁴³⁷
xA				
4 cyl. 1.5L	VO-40	VA-191	VCA-1042	NS ⁴³⁷
xB				
4 cyl. 1.5L	VO-40	VA-191	VCA-1042	NS ⁴³⁷
2004				
xA				
4 cyl. 1.5L	VO-40	VA-191	VCA-1042	NS ⁴³⁷
xB				
4 cyl. 1.5L	VO-40	VA-191	VCA-1042	NS ⁴³⁷

SHELBY

2000				
Series 1				
V8 4.0	VO-58			
1999				
Series 1				
V8 4.0	VO-58			

SMART

2015				
Fortwo				
3 cyl. 1.0L	VO-106			NS ⁴³⁷
2014				
Fortwo				
3 cyl. 1.0L	VO-106			NS ⁴³⁷
2013				
Fortwo				
3 cyl. 1.0L	VO-106			NS ⁴³⁷
2012				
Fortwo				
3 cyl. 1.0L	VO-106			NS ⁴³⁷
2011				
Fortwo				
3 cyl. 1.0L	VO-106			NS ⁴³⁷
2010				
Fortwo				
3 cyl. 1.0L	VO-106			NS ⁴³⁷
2009				
Fortwo				
3 cyl. 1.0L	VO-106			NS ⁴³⁷
2008				
Fortwo				
3 cyl. 1.0L	VO-106			NS ⁴³⁷
2007				
Fortwo				
3 cyl. 0.8L DI Turbo Diesel (Canada)	VO-120			
2006				
Fortwo				
3 cyl. 0.8L DI Turbo Diesel (Canada)	VO-120			

Se reporter à table de matière pour les notes en bas de page en français. Utilize el contenido para ver notas a pie.

NS - Non-Serviceable / Non réparable / No reparable LF - Life-Time Filter / Filtro para toda la vida / Filtre à vie

⁴³⁷ Requires replacement of the complete fuel pump/fuel filter module.



SMART (cont'd)

2005

Fortwo

3 cyl. 0.8L DI Turbo Diesel (Canada)

VO-120

SRT

2014

Viper

V10 8.4L

VO-88

VA-330

NS⁴³⁷

2013

Viper

V10 8.4L

VO-88

VA-330

NS⁴³⁷

STERLING

2010

Bullet

6 cyl 6.7L Diesel Turbo

VO-64

VA-264

2009

Bullet

6 cyl 6.7L Diesel Turbo

VO-64

VA-264

2008

Bullet

6 cyl 6.7L Diesel Turbo

VO-64

VA-264

SUBARU

2019

Ascent

4 cyl. 2.4L

VO-113

VA-498

VCA-2051

NS⁴³⁷

BRZ

4 cyl. 2.0L

VO-113

VA-171

VCA-1110⁶⁶⁷

NS⁴³⁷

Crosstrek

4 cyl. 2.0

VO-113

VA-498

VCA-2051

NS⁴³⁷

Forester

4 cyl. 2.5L

VO-113

VA-498

NS⁴³⁷

Impreza

4 cyl. 2.0L

VO-113

VA-498

VCA-2051

NS⁴³⁷

Legacy

4 cyl. 2.5L

VO-113

VA-198

VCA-1031

NS⁴³⁷

6 cyl 3.6L

VO-106

VA-198

VCA-1031

NS⁴³⁷

Outback

4 cyl. 2.5L

VO-113

VA-198

VCA-1031

NS⁴³⁷

6 cyl 3.6L

VO-106

VA-198

VCA-1031

NS⁴³⁷

WRX

4 cyl. 2.0L Turbo

VO-113

VA-198

VCA-1055

NS⁴³⁷

WRX STI

4 cyl. 2.5L Turbo

VO-113

VCA-1055

NS⁴³⁷

2018

BRZ

4 cyl. 2.0L

VO-113

VA-171

VCA-1110⁶⁶⁷

NS⁴³⁷

Crosstrek

4 cyl. 2.0

VO-113

VA-498

VCA-2051

NS⁴³⁷

Forester

4 cyl. 2.0L Turbo

VO-113

VA-198

VCA-1055

NS⁴³⁷

4 cyl. 2.5L

VO-113

VA-198

VCA-1055

NS⁴³⁷

Se reporter à table de matière pour les notes en bas de page en français. Utilize el contenido para ver notas a pie.

NS - Non-Serviceable / Non réparable / No reparable LF - Life-Time Filter / Filtro para toda la vida / Filtre à vie

⁴³⁷ Requires replacement of the complete fuel pump/fuel filter module. ⁶⁶⁷ Dust Filter



SUBARU (cont'd)

	Oil	Air	Cabin*	Fuel
2018				
Impreza				
4 cyl. 2.0L	VO-113	VA-498	VCA-2051	NS ⁴³⁷
Legacy				
4 cyl. 2.5L	VO-113	VA-198	VCA-1031	NS ⁴³⁷
6 cyl. 3.6L	VO-106	VA-198	VCA-1031	NS ⁴³⁷
Outback				
4 cyl. 2.5L	VO-113	VA-198	VCA-1031	NS ⁴³⁷
6 cyl. 3.6L	VO-106	VA-198	VCA-1031	NS ⁴³⁷
WRX				
4 cyl. 2.0L Turbo	VO-113	VA-198	VCA-1055	NS ⁴³⁷
WRX STI				
4 cyl. 2.5L Turbo	VO-113	VA-198	VCA-1055	NS ⁴³⁷
2017				
BRZ				
4 cyl. 2.0L	VO-113	VA-171	VCA-1110 ⁶⁶⁷	NS ⁴³⁷
Crosstrek				
4 cyl. 2.0	VO-113	VA-198	VCA-1055	NS ⁴³⁷
Forester				
4 cyl. 2.0L Turbo	VO-113	VA-198	VCA-1055	NS ⁴³⁷
4 cyl. 2.5L	VO-113	VA-198	VCA-1055	NS ⁴³⁷
Impreza				
4 cyl. 2.0L	VO-113	VA-498	VCA-2051	NS ⁴³⁷
Legacy				
4 cyl. 2.5L	VO-113	VA-198	VCA-1031	NS ⁴³⁷
6 cyl. 3.6L	VO-106	VA-198	VCA-1031	NS ⁴³⁷
Outback				
4 cyl. 2.5L	VO-113	VA-198	VCA-1031	NS ⁴³⁷
6 cyl. 3.6L	VO-106	VA-198	VCA-1031	NS ⁴³⁷
WRX				
4 cyl. 2.0L Turbo	VO-113	VA-198	VCA-1055	NS ⁴³⁷
WRX STI				
4 cyl. 2.5L Turbo	VO-113	VA-198	VCA-1055	NS ⁴³⁷
2016				
BRZ				
4 cyl. 2.0L	VO-113	VA-171	VCA-1110 ⁶⁶⁷	NS ⁴³⁷
Crosstrek				
4 cyl. 2.0	VO-113	VA-198	VCA-1055	NS ⁴³⁷
4 cyl. 2.0L Hybrid	VO-113		VCA-1055	NS ⁴³⁷
Forester				
4 cyl. 2.0L Turbo	VO-113	VA-198	VCA-1055	NS ⁴³⁷
4 cyl. 2.5L	VO-113	VA-198	VCA-1055	NS ⁴³⁷
Impreza				
4 cyl. 2.0L	VO-113	VA-198	VCA-1055	NS ⁴³⁷
Legacy				
4 cyl. 2.5L	VO-113	VA-198	VCA-1031	NS ⁴³⁷
6 cyl. 3.6L	VO-106	VA-198	VCA-1031	NS ⁴³⁷
Outback				
4 cyl. 2.5L	VO-113	VA-198	VCA-1031	NS ⁴³⁷
6 cyl. 3.6L	VO-106	VA-198	VCA-1031	NS ⁴³⁷
WRX				
4 cyl. 2.0L Turbo	VO-113	VA-198	VCA-1055	NS ⁴³⁷

Se reporter à table de matière pour les notes en bas de page en français. Utilize el contenido para ver notas a pie.

NS - Non-Serviceable / Non réparable / No repairable LF - Life-Time Filter / Filtro para toda la vida / Filtre à vie

⁴³⁷ Requires replacement of the complete fuel pump/fuel filter module. ⁶⁶⁷ Dust Filter



SUBARU (cont'd)

2016

WRX STI

4 cyl. 2.5L Turbo	VO-113	VA-198	VCA-1055	NS ⁴³⁷
-------------------	--------	--------	----------	-------------------

2015

BRZ

4 cyl. 2.0L	VO-113	VA-171	VCA-1110 ⁶⁶⁷	NS ⁴³⁷
-------------	--------	--------	-------------------------	-------------------

Forester

4 cyl. 2.0L Turbo	VO-113	VA-198	VCA-1055	NS ⁴³⁷
-------------------	--------	--------	----------	-------------------

4 cyl. 2.5L	VO-113	VA-198	VCA-1055	NS ⁴³⁷
-------------	--------	--------	----------	-------------------

Impreza

4 cyl. 2.0L	VO-113	VA-198	VCA-1055	NS ⁴³⁷
-------------	--------	--------	----------	-------------------

Legacy

4 cyl. 2.5L	VO-113	VA-198	VCA-1031	NS ⁴³⁷
-------------	--------	--------	----------	-------------------

6 cyl. 3.6L	VO-106	VA-198	VCA-1031	NS ⁴³⁷
-------------	--------	--------	----------	-------------------

Outback

4 cyl. 2.5L	VO-113	VA-198	VCA-1031	NS ⁴³⁷
-------------	--------	--------	----------	-------------------

6 cyl. 3.6L	VO-106	VA-198	VCA-1031	NS ⁴³⁷
-------------	--------	--------	----------	-------------------

WRX

4 cyl. 2.0L Turbo	VO-113	VA-198	VCA-1055	NS ⁴³⁷
-------------------	--------	--------	----------	-------------------

WRX STI

4 cyl. 2.5L Turbo	VO-113	VA-198	VCA-1055	NS ⁴³⁷
-------------------	--------	--------	----------	-------------------

XV Crosstrek

4 cyl. 2.0L	VO-113	VA-198	VCA-1055	NS ⁴³⁷
-------------	--------	--------	----------	-------------------

4 cyl. 2.0L Hybrid	VO-113		VCA-1055	NS ⁴³⁷
--------------------	--------	--	----------	-------------------

2014

BRZ

4 cyl. 2.0L	VO-113	VA-171	VCA-1110 ⁶⁶⁷	NS ⁴³⁷
-------------	--------	--------	-------------------------	-------------------

Forester

4 cyl. 2.0L Turbo	VO-113	VA-198	VCA-1055	NS ⁴³⁷
-------------------	--------	--------	----------	-------------------

4 cyl. 2.5L	VO-113	VA-198	VCA-1055	NS ⁴³⁷
-------------	--------	--------	----------	-------------------

Impreza

4 cyl. 2.0L	VO-113	VA-198	VCA-1055	NS ⁴³⁷
-------------	--------	--------	----------	-------------------

Impreza WRX

4 cyl. 2.5L Turbo	VO-113	VA-198	VCA-1055	NS ⁴³⁷
-------------------	--------	--------	----------	-------------------

Impreza WRX STI

4 cyl. 2.5L Turbo	VO-113	VA-198	VCA-1055	NS ⁴³⁷
-------------------	--------	--------	----------	-------------------

Legacy

4 cyl. 2.5L	VO-113	VA-198	VCA-1031	NS ⁴³⁷
-------------	--------	--------	----------	-------------------

6 cyl. 3.6L	VO-106	VA-198	VCA-1031	NS ⁴³⁷
-------------	--------	--------	----------	-------------------

Outback

4 cyl. 2.5L	VO-113	VA-198	VCA-1031	NS ⁴³⁷
-------------	--------	--------	----------	-------------------

6 cyl. 3.6L	VO-106	VA-198	VCA-1031	NS ⁴³⁷
-------------	--------	--------	----------	-------------------

Tribeca

6 cyl. 3.6L	VO-106	VA-198	VCA-1014 ¹¹³⁴	NS ⁴³⁷
-------------	--------	--------	--------------------------	-------------------

XV Crosstrek

4 cyl. 2.0L	VO-113	VA-198	VCA-1055	NS ⁴³⁷
-------------	--------	--------	----------	-------------------

4 cyl. 2.0L Hybrid	VO-113		VCA-1055	NS ⁴³⁷
--------------------	--------	--	----------	-------------------

2013

BRZ

4 cyl. 2.0L	VO-113	VA-171	VCA-1110 ⁶⁶⁷	NS ⁴³⁷
-------------	--------	--------	-------------------------	-------------------

Forester

4 cyl. 2.5L Non turbo	VO-113	VA-198	VCA-1055	NS ⁴³⁷
-----------------------	--------	--------	----------	-------------------

4 cyl. 2.5L Turbo	VO-113	VA-198	VCA-1055	NS ⁴³⁷
-------------------	--------	--------	----------	-------------------

Se reporter à table de matière pour les notes en bas de page en français. Utilize el contenido para ver notas a pie.

NS - Non-Serviceable / Non réparable / No reparable LF - Life-Time Filter / Filtro para toda la vida / Filtre à vie

⁴³⁷ Requires replacement of the complete fuel pump/fuel filter module. ⁶⁶⁷ Dust Filter ¹¹³⁴Dust Filter. Replace with VCA-1032 when stock is depleted.



SUBARU (cont'd)

	Oil	Air	Cabin*	Fuel
2013				
Impreza				
4 cyl. 2.0L	VO-113	VA-198	VCA-1055	NS ⁴³⁷
Impreza WRX				
4 cyl. 2.5L Turbo	VO-113	VA-198	VCA-1055	NS ⁴³⁷
Impreza WRX STI				
4 cyl. 2.5L Turbo	VO-113	VA-198	VCA-1055	NS ⁴³⁷
Legacy				
4 cyl. 2.5L	VO-113	VA-198	VCA-1031	NS ⁴³⁷
6 cyl. 3.6L	VO-106	VA-198	VCA-1031	NS ⁴³⁷
Outback				
4 cyl. 2.5L	VO-113	VA-198	VCA-1031	NS ⁴³⁷
6 cyl. 3.6L	VO-106	VA-198	VCA-1031	NS ⁴³⁷
Tribeca				
6 cyl. 3.6L	VO-106	VA-198	VCA-1014 ¹¹³⁴	NS ⁴³⁷
XV Crosstrek				
4 cyl. 2.0L	VO-113	VA-198	VCA-1055	NS ⁴³⁷
2012				
Forester				
4 cyl. 2.5L Non turbo	VO-113	VA-198	VCA-1055	NS ⁴³⁷
4 cyl. 2.5L Turbo	VO-113	VA-198	VCA-1055	NS ⁴³⁷
Impreza				
4 cyl. 2.0L	VO-113	VA-198	VCA-1055	NS ⁴³⁷
Impreza WRX				
4 cyl. 2.5L Turbo	VO-113	VA-198	VCA-1055	NS ⁴³⁷
Impreza WRX STI				
4 cyl. 2.5L Turbo	VO-113	VA-198	VCA-1055	NS ⁴³⁷
Legacy				
4 cyl. 2.5L Non turbo	VO-113	VA-198	VCA-1031	NS ⁴³⁷
4 cyl. 2.5L Turbo	VO-113	VA-198	VCA-1031	NS ⁴³⁷
6 cyl. 3.6L	VO-106	VA-198	VCA-1031	NS ⁴³⁷
Outback				
4 cyl. 2.5L	VO-113	VA-198	VCA-1031	NS ⁴³⁷
6 cyl. 3.6L	VO-106	VA-198	VCA-1031	NS ⁴³⁷
Tribeca				
6 cyl. 3.6L	VO-106	VA-198	VCA-1014 ¹¹³⁴	NS ⁴³⁷
2011				
Forester				
4 cyl. 2.5L Non turbo	VO-113	VA-198	VCA-1055	NS ⁴³⁷
4 cyl. 2.5L Turbo	VO-113	VA-198	VCA-1055	NS ⁴³⁷
Impreza, Outback Sport				
4 cyl. 2.5L Non turbo	VO-113	VA-198	VCA-1055	NS ⁴³⁷
Impreza WRX				
4 cyl. 2.5L Turbo	VO-113	VA-198	VCA-1055	NS ⁴³⁷
Impreza WRX STI				
4 cyl. 2.5L Turbo	VO-113	VA-198	VCA-1055	NS ⁴³⁷
Legacy				
4 cyl. 2.5L Non turbo	VO-113	VA-198	VCA-1031	NS ⁴³⁷
4 cyl. 2.5L Turbo	VO-113	VA-198	VCA-1031	NS ⁴³⁷
6 cyl. 3.6L	VO-106	VA-198	VCA-1031	NS ⁴³⁷
Outback				
4 cyl. 2.5L	VO-113	VA-198	VCA-1031	NS ⁴³⁷
6 cyl. 3.6L	VO-106	VA-198	VCA-1031	NS ⁴³⁷

Se reporter à table de matière pour les notes en bas de page en français. Utilize el contenido para ver notas a pie.

NS - Non-Serviceable / Non réparable / No reparable LF - Life-Time Filter / Filtro para toda la vida / Filtre à vie

⁴³⁷ Requires replacement of the complete fuel pump/fuel filter module. ¹¹³⁴Dust Filter. Replace with VCA-1032 when stock is depleted.



SUBARU (cont'd)

2011

Tribeca

6 cyl. 3.6L	VO-106	VA-198	VCA-1014 ¹¹³⁴	NS ⁴³⁷
-------------	--------	--------	--------------------------	-------------------

2010

Forester

4 cyl. 2.5L Non turbo	VO-113	VA-198	VCA-1055	NS ⁴³⁷
4 cyl. 2.5L Turbo	VO-113	VA-198	VCA-1055	NS ⁴³⁷

Impreza, Outback Sport

4 cyl. 2.5L	VO-113	VA-198	VCA-1055	NS ⁴³⁷
4 cyl. 2.5L Turbo	VO-113	VA-198	VCA-1055	NS ⁴³⁷

Impreza WRX

4 cyl. 2.5L Turbo	VO-113	VA-198	VCA-1055	NS ⁴³⁷
-------------------	--------	--------	----------	-------------------

Impreza WRX STI

4 cyl. 2.5L Turbo	VO-113	VA-198	VCA-1055	NS ⁴³⁷
-------------------	--------	--------	----------	-------------------

Legacy

4 cyl. 2.5L Non turbo	VO-113	VA-198	VCA-1031	NS ⁴³⁷
4 cyl. 2.5L Turbo	VO-113	VA-198	VCA-1031	NS ⁴³⁷
6 cyl. 3.6L	VO-106	VA-198	VCA-1031	NS ⁴³⁷

Outback

4 cyl. 2.5L	VO-113	VA-198	VCA-1031	NS ⁴³⁷
6 cyl. 3.6L	VO-106	VA-198	VCA-1031	NS ⁴³⁷

Tribeca

6 cyl. 3.6L	VO-106	VA-198	VCA-1014 ¹¹³⁴	NS ⁴³⁷
-------------	--------	--------	--------------------------	-------------------

2009

Forester

4 cyl. 2.5L FI Non Turbo	VO-113	VA-198	VCA-1055	NS ⁴³⁷
4 cyl. 2.5L FI Turbo	VO-113	VA-198	VCA-1055	NS ⁴³⁷

Impreza, Outback Sport

4 cyl. 2.5L	VO-113	VA-198	VCA-1055	NS ⁴³⁷
4 cyl. 2.5L Turbo	VO-113	VA-198	VCA-1055	NS ⁴³⁷

Impreza WRX

4 cyl. 2.5L FI Turbo	VO-113	VA-198	VCA-1055	NS ⁴³⁷
----------------------	--------	--------	----------	-------------------

Impreza WRX STI

4 cyl. 2.5L FI Turbo	VO-113	VA-198	VCA-1055	NS ⁴³⁷
----------------------	--------	--------	----------	-------------------

Legacy

4 cyl. 2.5L FI Non Turbo	VO-113	VA-198	VCA-1014 ¹¹³⁴	NS ⁴³⁷
4 cyl. 2.5L FI Turbo	VO-113	VA-198	VCA-1014 ¹¹³⁴	NS ⁴³⁷
6 cyl. 3.0L FI	VO-106	VA-198	VCA-1014 ¹¹³⁴	NS ⁴³⁷

Outback

4 cyl. 2.5L FI Non Turbo	VO-113	VA-198	VCA-1014 ¹¹³⁴	NS ⁴³⁷
4 cyl. 2.5L FI Turbo	VO-113	VA-198	VCA-1014 ¹¹³⁴	NS ⁴³⁷
6 cyl. 3.0L FI	VO-106	VA-198	VCA-1014 ¹¹³⁴	NS ⁴³⁷

Tribeca

6 cyl. 3.6L	VO-106	VA-198	VCA-1014 ¹¹³⁴	NS ⁴³⁷
-------------	--------	--------	--------------------------	-------------------

2008

Forester

4 cyl. 2.5L FI Non Turbo	VO-113	VA-86	VCA-1114	NS ⁴³⁷
4 cyl. 2.5L FI Turbo	VO-113	VA-86	VCA-1114	NS ⁴³⁷

Impreza, Outback Sport

4 cyl. 2.5L FI	VO-113	VA-198	VCA-1055	NS ⁴³⁷
----------------	--------	--------	----------	-------------------

Impreza WRX

4 cyl. 2.5L FI Turbo	VO-113	VA-198	VCA-1055	NS ⁴³⁷
----------------------	--------	--------	----------	-------------------

Se reporter à table de matière pour les notes en bas de page en français. Utilize el contenido para ver notas a pie.

NS - Non-Serviceable / Non réparable / No reparable LF - Life-Time Filter / Filtro para toda la vida / Filtre à vie

⁴³⁷ Requires replacement of the complete fuel pump/fuel filter module. ¹¹³⁴Dust Filter. Replace with VCA-1032 when stock is depleted.



SUBARU (cont'd)

	Oil	Air	Cabin*	Fuel
2008				
Impreza WRX STI				
4 cyl. 2.5L FI Turbo	VO-113	VA-198	VCA-1055	NS ⁴³⁷
Legacy				
4 cyl. 2.5L FI Non Turbo	VO-113	VA-198	VCA-1014 ¹¹³⁴	NS ⁴³⁷
4 cyl. 2.5L FI Turbo	VO-113	VA-198	VCA-1014 ¹¹³⁴	NS ⁴³⁷
6 cyl. 3.0L FI	VO-106	VA-198	VCA-1014 ¹¹³⁴	NS ⁴³⁷
Outback				
4 cyl. 2.5L FI Non Turbo	VO-113	VA-198	VCA-1014 ¹¹³⁴	NS ⁴³⁷
4 cyl. 2.5L FI Turbo	VO-113	VA-198	VCA-1014 ¹¹³⁴	NS ⁴³⁷
6 cyl. 3.0L FI	VO-106	VA-198	VCA-1014 ¹¹³⁴	NS ⁴³⁷
Tribeca				
6 cyl. 3.6L	VO-106	VA-198	VCA-1014 ¹¹³⁴	NS ⁴³⁷
2007				
B9 Tribeca				
6 cyl. 3.0L FI	VO-106	VA-198	VCA-1014 ¹¹³⁴	NS ⁴³⁷
Forester				
4 cyl. 2.5L FI Non Turbo	VO-113	VA-86	VCA-1114	NS ⁴³⁷
4 cyl. 2.5L FI Turbo	VO-113	VA-86	VCA-1114	NS ⁴³⁷
Impreza, Outback Sport				
4 cyl. 2.5L FI	VO-113	VA-86		NS ⁴³⁷
Impreza WRX				
4 cyl. 2.5L FI Turbo	VO-113	VA-86		NS ⁴³⁷
Impreza WRX STI				
4 cyl. 2.5L FI Turbo	VO-113	VA-86		NS ⁴³⁷
Legacy				
4 cyl. 2.5L FI Non Turbo	VO-113	VA-198	VCA-1014 ¹¹³⁴	NS ⁴³⁷
4 cyl. 2.5L FI Turbo	VO-113	VA-198	VCA-1014 ¹¹³⁴	NS ⁴³⁷
Outback				
4 cyl. 2.5L FI Non Turbo	VO-113	VA-198	VCA-1014 ¹¹³⁴	NS ⁴³⁷
4 cyl. 2.5L FI Turbo	VO-113	VA-198	VCA-1014 ¹¹³⁴	NS ⁴³⁷
6 cyl. 3.0L FI	VO-106	VA-198	VCA-1014 ¹¹³⁴	NS ⁴³⁷
2006				
B9 Tribeca				
6 cyl. 3.0L FI	VO-106	VA-198	VCA-1014 ¹¹³⁴	NS ⁴³⁷
Baja				
4 cyl. 2.5L FI Non Turbo	VO-113	VA-150	VCA-1145	NS ⁴³⁷
4 cyl. 2.5L FI Turbo	VO-113	VA-86	VCA-1145	NS ⁴³⁷
Forester				
4 cyl. 2.5L FI Non Turbo	VO-113	VA-86	VCA-1114	NS ⁴³⁷
4 cyl. 2.5L FI Turbo	VO-113	VA-86	VCA-1114	NS ⁴³⁷
Impreza, Outback Sport				
4 cyl. 2.5L FI	VO-113	VA-86		NS ⁴³⁷
Impreza WRX				
4 cyl. 2.5L FI Turbo	VO-113	VA-86		NS ⁴³⁷
Impreza WRX STI				
4 cyl. 2.5L FI Turbo	VO-113	VA-86		NS ⁴³⁷
Legacy				
4 cyl. 2.5L FI Non Turbo	VO-113	VA-198	VCA-1014 ¹¹³⁴	NS ⁴³⁷
4 cyl. 2.5L FI Turbo	VO-113	VA-198	VCA-1014 ¹¹³⁴	NS ⁴³⁷
Outback				
4 cyl. 2.5L FI Non Turbo	VO-113	VA-198	VCA-1014 ¹¹³⁴	NS ⁴³⁷
4 cyl. 2.5L FI Turbo	VO-113	VA-198	VCA-1014 ¹¹³⁴	NS ⁴³⁷

Se reporter à table de matière pour les notes en bas de page en français. Utilize el contenido para ver notas a pie.

NS - Non-Serviceable / Non réparable / No repairable LF - Life-Time Filter / Filtro para toda la vida / Filtre à vie

⁴³⁷ Requires replacement of the complete fuel pump/fuel filter module. ¹¹³⁴Dust Filter. Replace with VCA-1032 when stock is depleted.



SUBARU (cont'd)

2006

Outback

6 cyl. 3.0L FI	VO-106	VA-198	VCA-1014 ¹¹³⁴	
----------------	--------	--------	--------------------------	--

2005

Baja

4 cyl. 2.5L FI Non Turbo	VO-113	VA-150	VCA-1145	NS ⁴³⁷
4 cyl. 2.5L FI Turbo	VO-113	VA-86	VCA-1145	NS ⁴³⁷

Forester

4 cyl. 2.5L FI Non Turbo	VO-113	VA-86	VCA-1114	NS ⁴³⁷
4 cyl. 2.5L FI Turbo	VO-113	VA-86	VCA-1114	NS ⁴³⁷

Impreza, Outback Sport

4 cyl. 2.5L FI	VO-113	VA-86		NS ⁴³⁷
----------------	--------	-------	--	-------------------

Impreza WRX

4 cyl. 2.0L FI Turbo	VO-113	VA-86		NS ⁴³⁷
----------------------	--------	-------	--	-------------------

Impreza WRX STI

4 cyl. 2.5L FI Turbo	VO-113	VA-86		NS ⁴³⁷
----------------------	--------	-------	--	-------------------

Legacy

4 cyl. 2.5L FI Non Turbo	VO-113	VA-198	VCA-1014 ¹¹³⁴	NS ⁴³⁷
4 cyl. 2.5L FI Turbo	VO-113	VA-198	VCA-1014 ¹¹³⁴	NS ⁴³⁷

Outback

4 cyl 2.5L FI Non Turbo	VO-113	VA-198	VCA-1014 ¹¹³⁴	NS ⁴³⁷
4 cyl 2.5L FI Turbo	VO-113	VA-198	VCA-1014 ¹¹³⁴	NS ⁴³⁷
6 cyl. 3.0L FI	VO-106	VA-198	VCA-1014 ¹¹³⁴	NS ⁴³⁷

2004

Baja

4 cyl. 2.5L FI Non Turbo	VO-113	VA-150	VCA-1145	
4 cyl. 2.5L FI Turbo	VO-113	VA-86	VCA-1145	

Forester

4 cyl. 2.5L FI Non Turbo	VO-113	VA-150	VCA-1114	
4 cyl. 2.5L FI Turbo	VO-113	VA-86	VCA-1114	

Impreza, Outback Sport

4 cyl. 2.5L FI	VO-113	VA-150		
----------------	--------	--------	--	--

Impreza WRX

4 cyl. 2.0L FI Turbo	VO-113	VA-86		
----------------------	--------	-------	--	--

Impreza WRX STI

4 cyl. 2.5L FI Turbo	VO-113	VA-86		
----------------------	--------	-------	--	--

Legacy

4 cyl. 2.5L FI	VO-113	VA-150 ^{X039} VA-86 ^{Z039}	VCA-1145	
----------------	--------	---	----------	--

Outback

4 cyl. 2.5L FI	VO-113	VA-150 ^{X039} VA-86 ^{Z039}	VCA-1145	
6 cyl. 3.0L FI	VO-106	VA-86	VCA-1145	

2003

Baja

4 cyl. 2.5L FI Non Turbo	VO-113	VA-150	VCA-1145	
--------------------------	--------	--------	----------	--

Forester

4 cyl. 2.5L FI	VO-113	VA-150	VCA-1114	
----------------	--------	--------	----------	--

Impreza, Outback Sport

4 cyl. 2.5L FI	VO-113	VA-150		
----------------	--------	--------	--	--

Impreza WRX

4 cyl. 2.0L FI Turbo	VO-113	VA-86		
----------------------	--------	-------	--	--

Se reporter à table de matière pour les notes en bas de page en français. Utilize el contenido para ver notas a pie.

NS - Non-Serviceable / Non réparable / No repairable LF - Life-Time Filter / Filtro para toda la vida / Filtre à vie

⁴³⁷ Requires replacement of the complete fuel pump/fuel filter module. ¹¹³⁴Dust Filter. Replace with VCA-1032 when stock is depleted. ^{X039}14 1/2 inch long
^{Z039}11 inch long.



SUBARU (cont'd)

	Oil	Air	Cabin*	Fuel
2003				
Legacy				
4 cyl. 2.5L FI	VO-113	VA-150	VCA-1145	
Outback				
4 cyl. 2.5L FI	VO-113	VA-150	VCA-1145	
6 cyl. 3.0L FI	VO-106	VA-86	VCA-1145	
2002				
Forester				
4 cyl. 2.5L FI	VO-113	VA-150		
Impreza, Outback Sport				
4 cyl. 2.5L FI	VO-113	VA-150		
Impreza WRX				
4 cyl. 2.0L FI Turbo	VO-113	VA-86		
Legacy				
4 cyl. 2.5L FI	VO-113	VA-150	VCA-1145	
Outback				
4 cyl. 2.5L FI	VO-113	VA-150	VCA-1145	
6 cyl. 3.0L FI	VO-106	VA-86	VCA-1145	
2001				
Forester				
4 cyl. 2.5L FI	VO-113	VA-150		
Impreza, Outback Sport				
4 cyl. 2.2L FI	VO-113	VA-150		
4 cyl. 2.5L FI	VO-113	VA-150		
Legacy				
4 cyl. 2.5L FI	VO-113	VA-150	VCA-1145	
Outback				
4 cyl. 2.5L FI	VO-113	VA-150	VCA-1145	
6 cyl. 3.0L FI	VO-106	VA-86	VCA-1145	
2000				
Forester				
4 cyl. 2.5L FI	VO-106	VA-150		
Impreza, Outback Sport				
4 cyl. 2.2L FI	VO-106	VA-150		
4 cyl. 2.5L FI	VO-106	VA-150		
Legacy				
4 cyl. 2.5L FI	VO-106	VA-150	VCA-1145	
Outback				
4 cyl. 2.5L FI	VO-106	VA-150	VCA-1145	
1999				
Forester				
4 cyl. 2.5L FI	VO-106	VA-86		
Impreza, Outback Sport				
4 cyl. 2.2L FI	VO-106	VA-86 ^{X556} VA-150 ^{Z556}		
4 cyl. 2.5L FI	VO-106	VA-86		
Legacy				
4 cyl. 2.2L FI	VO-106	VA-86 ^{X556} VA-150 ^{Z556}		
4 cyl. 2.5L FI	VO-106	VA-86		
1998				
Forester				
4 cyl. 2.5L FI	VO-106	VA-86		

Se reporter à table de matière pour les notes en bas de page en français. Utilize el contenido para ver notas a pie.

NS - Non-Serviceable / Non réparable / No reparable LF - Life-Time Filter / Filtro para toda la vida / Filtre à vie

^{X556}Except California models. ^{Z556}California



SUBARU (cont'd)

1998

Impreza, Outback Sport

4 cyl. 2.2L FI	VO-106	VA-86		
4 cyl. 2.5L FI	VO-106	VA-86		

Legacy

4 cyl. 2.2L FI	VO-106	VA-86		
4 cyl. 2.5L FI	VO-106	VA-86		

1997

Impreza, Outback Sport

4 cyl. 1.8L FI	VO-106	VA-86		
4 cyl. 2.2L FI	VO-106	VA-86		

Legacy

4 cyl. 2.2L FI	VO-106	VA-86		
4 cyl. 2.5L FI	VO-106	VA-86		

SVX

6 cyl. 3.3L FI	VO-106	VA-86		
----------------	--------	-------	--	--

1996

Impreza, Outback Sport

4 cyl. 1.8L FI	VO-106	VA-86		
4 cyl. 2.2L FI	VO-106	VA-86		

Legacy

4 cyl. 2.2L FI	VO-106	VA-86		
4 cyl. 2.5L FI	VO-106	VA-86		

SVX

6 cyl. 3.3L FI	VO-106	VA-86		
----------------	--------	-------	--	--

1995

Impreza, Outback Sport

4 cyl. 1.8L FI	VO-106	VA-86		
4 cyl. 2.2L FI	VO-106	VA-86		

Justy

3 cyl. 1.2L FI (Canada)	VO-113			
-------------------------	--------	--	--	--

Legacy

4 cyl. 2.2L FI	VO-106	VA-86		
----------------	--------	-------	--	--

SVX

6 cyl. 3.3L FI	VO-106	VA-86		
----------------	--------	-------	--	--

1994

SVX

6 cyl. 3.3L FI	VO-106	VA-86		
----------------	--------	-------	--	--

SUZUKI

2013

Grand Vitara

4 cyl. 2.4L FI	VO-40	VA-385	VCA-1109	NS ⁴³⁷
----------------	-------	--------	----------	-------------------

Kizashi

4 cyl. 2.4L FI	VO-40			NS ⁴³⁷
----------------	-------	--	--	-------------------

SX4

4 cyl. 2.0L FI	VO-40		VCA-1117	NS ⁴³⁷
----------------	-------	--	----------	-------------------

2012

Equator

4 cyl. 2.5L FI	VO-106	VA-356	VCA-1041	NS ⁴³⁷
V6 4.0L FI	VO-106	VA-105	VCA-1041	NS ⁴³⁷

Grand Vitara

4 cyl. 2.4L FI	VO-40	VA-385	VCA-1109	NS ⁴³⁷
----------------	-------	--------	----------	-------------------

Se reporter à table de matière pour les notes en bas de page en français. Utilize el contenido para ver notas a pie.

NS - Non-Serviceable / Non réparable / No reparable LF - Life-Time Filter / Filtro para toda la vida / Filtre à vie

⁴³⁷ Requires replacement of the complete fuel pump/fuel filter module.



SUZUKI (cont'd)

	Oil	Air	Cabin*	Fuel
2012				
Kizashi				
4 cyl. 2.4L FI	VO-40			NS ⁴³⁷
SX4				
4 cyl. 2.0L FI	VO-40		VCA-1117	NS ⁴³⁷
2011				
Equator				
4 cyl. 2.5L FI	VO-106	VA-356	VCA-1041	NS ⁴³⁷
V6 4.0L FI	VO-106	VA-105	VCA-1041	NS ⁴³⁷
Grand Vitara				
4 cyl. 2.4L FI	VO-40	VA-385	VCA-1109	NS ⁴³⁷
Kizashi				
4 cyl. 2.4L FI	VO-40			NS ⁴³⁷
SX4				
4 cyl. 2.0L FI	VO-40		VCA-1117	NS ⁴³⁷
2010				
Equator				
4 cyl. 2.5L FI	VO-106	VA-356	VCA-1041	NS ⁴³⁷
V6 4.0L FI	VO-106	VA-105	VCA-1041	NS ⁴³⁷
Grand Vitara				
4 cyl. 2.4L FI	VO-40	VA-385	VCA-1109	NS ⁴³⁷
V6 3.2L FI	VO-88	VA-385	VCA-1109	NS ⁴³⁷
Kizashi				
4 cyl. 2.4L FI	VO-40			NS ⁴³⁷
SX4				
4 cyl. 2.0L FI	VO-40		VCA-1117	NS ⁴³⁷
2009				
Equator				
4 cyl. 2.5L FI	VO-106	VA-356	VCA-1041	NS ⁴³⁷
V6 4.0L FI	VO-106	VA-105	VCA-1041	NS ⁴³⁷
Grand Vitara				
4 cyl. 2.4L FI	VO-40	VA-385	VCA-1109	NS ⁴³⁷
V6 3.2L FI	VO-88	VA-385	VCA-1109	NS ⁴³⁷
Swift+ (Canada)				
4 cyl. 1.6L FI	VO-98	VA-188	VCA-1146	NS ⁴³⁷
SX4				
4 cyl. 2.0L FI	VO-40	VA-368	VCA-1117	NS ⁴³⁷
XL7				
V6 3.6L FI	VO-88	VA-176	VCA-1030	NS ⁴³⁷
2008				
Foreza				
4 cyl. 2.0L FI	VO-16	VA-340	VCA-1155	NS ⁴³⁷
Grand Vitara				
V6 2.7L FI	VO-25	VA-374	VCA-1109	
Reno				
4 cyl. 2.0L FI	VO-16	VA-340	VCA-1155	NS ⁴³⁷
Swift+ (Canada)				
4 cyl. 1.6L FI	VO-16	VA-188	VCA-1146	
SX4				
4 cyl. 2.0L FI	VO-40	VA-368	VCA-1117	NS ⁴³⁷
XL7				
V6 3.6L FI	VO-88	VA-176	VCA-1030	NS ⁴³⁷

Se reporter à table de matière pour les notes en bas de page en français. Utilize el contenido para ver notas a pie.

NS - Non-Serviceable / Non réparable / No repairable LF - Life-Time Filter / Filtro para toda la vida / Filtre à vie

⁴³⁷ Requires replacement of the complete fuel pump/fuel filter module.



SUZUKI (cont'd)

2007

Aerio

4 cyl. 2.3L FI	VO-40	VA-377		NS ⁴³⁷
----------------	-------	--------	--	-------------------

Forenza

4 cyl. 2.0L FI	VO-16	VA-340	VCA-1155	NS ⁴³⁷
----------------	-------	--------	----------	-------------------

Grand Vitara

V6 2.7L FI	VO-25	VA-374	VCA-1109	
------------	-------	--------	----------	--

Reno

4 cyl. 2.0L FI	VO-16	VA-340	VCA-1155	NS ⁴³⁷
----------------	-------	--------	----------	-------------------

Swift+ (Canada)

4 cyl. 1.6L FI	VO-16	VA-188	VCA-1146	
----------------	-------	--------	----------	--

SX4

4 cyl. 2.0L FI	VO-40	VA-368	VCA-1117	NS ⁴³⁷
----------------	-------	--------	----------	-------------------

XL7

V6 3.6L FI	VO-88	VA-176	VCA-1030	NS ⁴³⁷
------------	-------	--------	----------	-------------------

2006

Aerio

4 cyl. 2.3L FI	VO-40	VA-377		NS ⁴³⁷
----------------	-------	--------	--	-------------------

Forenza

4 cyl. 2.0L FI	VO-16	VA-340	VCA-1155	NS ⁴³⁷
----------------	-------	--------	----------	-------------------

Grand Vitara

V6 2.7L FI	VO-25	VA-374	VCA-1109	
------------	-------	--------	----------	--

Reno

4 cyl. 2.0L FI	VO-16	VA-340	VCA-1155	NS ⁴³⁷
----------------	-------	--------	----------	-------------------

Swift+ (Canada)

4 cyl. 1.6L FI	VO-16	VA-188	VCA-1146	
----------------	-------	--------	----------	--

Verona

6 cyl. 2.5L FI	VO-52	VA-386		
----------------	-------	--------	--	--

XL7

V6 2.7L FI	VO-25	VA-379	VCA-1134	
------------	-------	--------	----------	--

2005

Aerio

4 cyl. 2.3L FI	VO-40	VA-377		NS ⁴³⁷
----------------	-------	--------	--	-------------------

Forenza

4 cyl. 2.0L FI	VO-16	VA-340	VCA-1155	NS ⁴³⁷
----------------	-------	--------	----------	-------------------

Grand Vitara

V6 2.5L FI	VO-25	VA-144	VCA-1134	
------------	-------	--------	----------	--

Reno

4 cyl. 2.0L FI	VO-16	VA-340	VCA-1155	NS ⁴³⁷
----------------	-------	--------	----------	-------------------

Swift+ (Canada)

4 cyl. 1.6L FI	VO-16	VA-188	VCA-1146	
----------------	-------	--------	----------	--

Verona

6 cyl. 2.5L FI	VO-52	VA-386		
----------------	-------	--------	--	--

XL7

V6 2.7L FI	VO-25	VA-379	VCA-1134	
------------	-------	--------	----------	--

2004

Aerio

4 cyl. 2.3L FI	VO-40	VA-377		NS ⁴³⁷
----------------	-------	--------	--	-------------------

Forenza

4 cyl. 2.0L FI	VO-16	VA-340	VCA-1155	NS ⁴³⁷
----------------	-------	--------	----------	-------------------

Grand Vitara

V6 2.5L FI	VO-25	VA-144	VCA-1134	
------------	-------	--------	----------	--

Se reporter à table de matière pour les notes en bas de page en français. Utilize el contenido para ver notas a pie.

NS - Non-Serviceable / Non réparable / No repairable LF - Life-Time Filter / Filtro para toda la vida / Filtre à vie

⁴³⁷ Requires replacement of the complete fuel pump/fuel filter module.



SUZUKI (cont'd)

	Oil	Air	Cabin*	Fuel
2004				
Swift+ (Canada)				
4 cyl. 1.6L FI	VO-16	VA-188	VCA-1146	
Verona				
6 cyl. 2.5L FI	VO-52	VA-386		
Vitara				
V6 2.5L FI	VO-25	VA-144	VCA-1160	
XL7				
V6 2.7L FI	VO-25	VA-379	VCA-1134	
2003				
Aerio				
4 cyl. 2.0L FI	VO-40	VA-377		NS ⁴³⁷
Grand Vitara				
V6 2.5L FI	VO-25	VA-144	VCA-1134	
Vitara				
4 cyl. 2.0L FI	VO-40	VA-144	VCA-1160	
XL7				
V6 2.7L FI	VO-25	VA-144	VCA-1134	
2002				
Aerio				
4 cyl. 2.0L FI	VO-40			NS ⁴³⁷
Esteem				
4 cyl. 1.8L FI	VO-40			NS ⁴³⁷
Grand Vitara				
V6 2.5L FI	VO-25	VA-144	VCA-1160	
Vitara				
4 cyl. 1.6L FI	VO-40	VA-144	VCA-1160	
4 cyl. 2.0L FI	VO-40	VA-144	VCA-1160	
XL7				
V6 2.7L FI	VO-25	VA-144	VCA-1160	
2001				
Esteem				
4 cyl. 1.6L FI (Canada)	VO-25			
4 cyl. 1.8L FI	VO-40			NS ⁴³⁷
Grand Vitara				
V6 2.5L FI	VO-25	VA-144	VCA-1160	
V6 2.7L FI	VO-25	VA-144	VCA-1160	
Swift				
4 cyl. 1.3L FI	VO-40			NS ⁴³⁷
Vitara				
4 cyl. 1.6L FI	VO-40	VA-144	VCA-1160	
4 cyl. 2.0L FI	VO-40	VA-144	VCA-1160	
2000				
Esteem				
4 cyl. 1.6L FI	VO-25			
4 cyl. 1.8L FI	VO-40			
Grand Vitara				
V6 2.5L FI	VO-25	VA-144	VCA-1160	
Swift				
4 cyl. 1.3L FI	VO-25			NS ⁴³⁷
Vitara				
4 cyl. 1.6L FI	VO-40	VA-144	VCA-1160	
4 cyl. 2.0L FI	VO-40	VA-144	VCA-1160	

Se reporter à table de matière pour les notes en bas de page en français. Utilize el contenido para ver notas a pie.

NS - Non-Serviceable / Non réparable / No reparable LF - Life-Time Filter / Filtro para toda la vida / Filtre à vie

⁴³⁷ Requires replacement of the complete fuel pump/fuel filter module.



SUZUKI (cont'd)

1999

Esteem

4 cyl. 1.6L FI	VO-25			
4 cyl. 1.8L FI	VO-40			

Grand Vitara

V6 2.5L FI	VO-25	VA-144	VCA-1160	
------------	-------	--------	----------	--

Swift

4 cyl. 1.3L FI	VO-25			NS ⁴³⁷
----------------	-------	--	--	-------------------

Vitara

4 cyl. 1.6L FI	VO-40	VA-144	VCA-1160	
4 cyl. 2.0L FI	VO-40	VA-144	VCA-1160	

1998

Esteem

4 cyl. 1.6L FI	VO-25			
----------------	-------	--	--	--

Sidekick

4 cyl. 1.6L FI	VO-25			
4 cyl. 1.8L FI	VO-40	VA-144		

Swift

4 cyl. 1.3L FI	VO-25			NS ⁴³⁷
----------------	-------	--	--	-------------------

X-90

4 cyl. 1.6L FI	VO-25			
----------------	-------	--	--	--

1997

Esteem

4 cyl. 1.6L FI	VO-25			
----------------	-------	--	--	--

Sidekick

4 cyl. 1.6L FI	VO-25			
4 cyl. 1.8L FI	VO-40	VA-144		

Swift

4 cyl. 1.3L FI	VO-25			
----------------	-------	--	--	--

X-90

4 cyl. 1.6L FI	VO-25			
----------------	-------	--	--	--

1996

Esteem

4 cyl. 1.6L FI	VO-25			
----------------	-------	--	--	--

Sidekick

4 cyl. 1.6L FI	VO-25			
4 cyl. 1.8L FI	VO-40	VA-144		

Swift

4 cyl. 1.3L FI	VO-25			
----------------	-------	--	--	--

X-90

4 cyl. 1.6L FI	VO-25			
----------------	-------	--	--	--

1995

Esteem

4 cyl. 1.6L FI	VO-25			
----------------	-------	--	--	--

Samurai

4 cyl. 1.3L FI	VO-25			
----------------	-------	--	--	--

Sidekick

4 cyl. 1.6L FI (16 valve)	VO-25			
4 cyl. 1.6L FI (8 valve)	VO-25			

Swift

4 cyl. 1.3L FI	VO-25			
----------------	-------	--	--	--

--	--	--	--	--

Se reporter à table de matière pour les notes en bas de page en français. Utilize el contenido para ver notas a pie.

NS - Non-Serviceable / Non réparable / No reparable LF - Life-Time Filter / Filtro para toda la vida / Filtre à vie

⁴³⁷ Requires replacement of the complete fuel pump/fuel filter module.



SUZUKI (cont'd)

1994

Samurai

4 cyl. 1.3L FI	VO-25			
----------------	-------	--	--	--

TOYOTA

2019

4-Runner

V6 4.0L	VO-87	VA-256	VCA-1031	NS ⁴³⁷
---------	-------	--------	----------	-------------------

86

4 cyl. 2.0L	VO-113	VA-171	VCA-1110	NS ⁴³⁷
-------------	--------	--------	----------	-------------------

Avalon

4 cyl. 2.5L Hybrid	VO-175	VA-500	VCA-2035	NS ⁴³⁷
--------------------	--------	--------	----------	-------------------

V6 3.5L	VO-84	VA-273	VCA-2035	NS ⁴³⁷
---------	-------	--------	----------	-------------------

Camry

4 cyl. 2.5L	VO-175	VA-273	VCA-2035	NS ⁴³⁷
-------------	--------	--------	----------	-------------------

4 cyl. 2.5L Hybrid	VO-175	VA-500	VCA-2035	NS ⁴³⁷
--------------------	--------	--------	----------	-------------------

V6 3.5L	VO-84	VA-273	VCA-2035	NS ⁴³⁷
---------	-------	--------	----------	-------------------

C-HR

4 cyl. 2.0L	VO-102 ^{X967}			
-------------	------------------------	--	--	--

	VO-40 ^{Z967}	VA-500	VCA-2055	NS ⁴³⁷
--	-----------------------	--------	----------	-------------------

Corolla

4 cyl. 1.8L	VO-40 ^{X905}			
-------------	-----------------------	--	--	--

	VO-102 ^{Z905}	VA-231	VCA-1031	NS ⁴³⁷
--	------------------------	--------	----------	-------------------

4 cyl. 2.0L	VO-175	VA-500	VCA-2035	NS ⁴³⁷
-------------	--------	--------	----------	-------------------

Highlander

4 cyl. 2.7L	VO-84	VA-273	VCA-1031	NS ⁴³⁷
-------------	-------	--------	----------	-------------------

V6 3.5L GAS	VO-84	VA-273	VCA-1031	NS ⁴³⁷
-------------	-------	--------	----------	-------------------

V6 3.5L Hybrid	VO-84		VCA-1031	NS ⁴³⁷
----------------	-------	--	----------	-------------------

Land Cruiser

V8 5.7L	VO-96	VA-234	VCA-1031	NS ⁴³⁷
---------	-------	--------	----------	-------------------

Mirai

-- Electric/Hydrogen			VCA-1031	
----------------------	--	--	----------	--

Prius C

4 cyl. 1.5L Hybrid	VO-40	VA-344	VCA-1031	NS ⁴³⁷
--------------------	-------	--------	----------	-------------------

Prius Prime

4 cyl. 1.8 Hybrid	VO-40 ^{X905}			
-------------------	-----------------------	--	--	--

	VO-102 ^{Z905}	VA-344	VCA-2035	NS ⁴³⁷
--	------------------------	--------	----------	-------------------

RAV4

4 cyl. 2.5L	VO-84	VA-390	VCA-2035	NS ⁴³⁷
-------------	-------	--------	----------	-------------------

Sequoia

V8 5.7L	VO-96	VA-440	VCA-1031	NS ⁴³⁷
---------	-------	--------	----------	-------------------

Sienna

V6 3.5L	VO-84	VA-273	VCA-1031	NS ⁴³⁷
---------	-------	--------	----------	-------------------

Tacoma

4 cyl. 2.7L	VO-25	VA-248	VCA-1037	NS ⁴³⁷
-------------	-------	--------	----------	-------------------

V6 3.5L	VO-84	VA-440	VCA-1037	NS ⁴³⁷
---------	-------	--------	----------	-------------------

Tundra

V8 4.6L	VO-96	VA-440	VCA-1031	NS ⁴³⁷
---------	-------	--------	----------	-------------------

V8 5.7L	VO-96	VA-440	VCA-1031	NS ⁴³⁷
---------	-------	--------	----------	-------------------

Yaris

4 cyl. 1.5 (P5)	VO-106			NS ⁴³⁷
-----------------	--------	--	--	-------------------

4 cyl. 1.5L (1NZFE)	VO-40	VA-231	VCA-1031	NS ⁴³⁷
---------------------	-------	--------	----------	-------------------

Se reporter à table de matière pour les notes en bas de page en français. Utilize el contenido para ver notas a pie.

NS - Non-Serviceable / Non réparable / No repairable LF - Life-Time Filter / Filtro para toda la vida / Filtre à vie

⁴³⁷ Requires replacement of the complete fuel pump/fuel filter module. ^{X905}Spin-on filter ^{X967}Cartridge filter ^{Z905}Cartridge filter ^{Z967}Spin-on filter



TOYOTA (cont'd)

2018

4-Runner

V6 4.0L	VO-87	VA-256	VCA-1031	NS ⁴³⁷
---------	-------	--------	----------	-------------------

86

4 cyl. 2.0L	VO-113	VA-171	VCA-1110	NS ⁴³⁷
-------------	--------	--------	----------	-------------------

Avalon

4 cyl. 2.5L Hybrid	VO-84	VA-309	VCA-1031	NS ⁴³⁷
--------------------	-------	--------	----------	-------------------

V6 3.5L	VO-84	VA-273	VCA-1031	NS ⁴³⁷
---------	-------	--------	----------	-------------------

Camry

4 cyl 2.5L	VO-175	VA-273	VCA-2035	NS ⁴³⁷
------------	--------	--------	----------	-------------------

4 cyl 2.5L Hybrid	VO-175	VA-500	VCA-2035	NS ⁴³⁷
-------------------	--------	--------	----------	-------------------

V6 3.5L	VO-84	VA-273	VCA-2035	NS ⁴³⁷
---------	-------	--------	----------	-------------------

C-HR

4 cyl. 2.0L	VO-102 ^{X967}			
-------------	------------------------	--	--	--

	VO-40 ^{Z967}	VA-500	VCA-2055	NS ⁴³⁷
--	-----------------------	--------	----------	-------------------

Corolla

4 cyl. 1.8L	VO-40 ^{X905}			
-------------	-----------------------	--	--	--

	VO-102 ^{Z905}	VA-231	VCA-1031	NS ⁴³⁷
--	------------------------	--------	----------	-------------------

Corolla iM

4 cyl. 1.8L	VO-40	VA-231	VCA-1031	NS ⁴³⁷
-------------	-------	--------	----------	-------------------

Highlander

4 cyl 2.7L	VO-84	VA-273	VCA-1031	NS ⁴³⁷
------------	-------	--------	----------	-------------------

V6 3.5L GAS	VO-84	VA-273	VCA-1031	NS ⁴³⁷
-------------	-------	--------	----------	-------------------

V6 3.5L Hybrid	VO-84		VCA-1031	NS ⁴³⁷
----------------	-------	--	----------	-------------------

Land Cruiser

V8 5.7L	VO-96	VA-234	VCA-1031	NS ⁴³⁷
---------	-------	--------	----------	-------------------

Mirai

-- Electric/Hydrogen			VCA-1031	
----------------------	--	--	----------	--

Prius

4 cyl. 1.8L Hybrid	VO-40 ^{X905}			
--------------------	-----------------------	--	--	--

	VO-102 ^{Z905}	VA-344	VCA-2035	NS ⁴³⁷
--	------------------------	--------	----------	-------------------

Prius C

4 cyl. 1.5L Hybrid	VO-40	VA-344	VCA-1031	NS ⁴³⁷
--------------------	-------	--------	----------	-------------------

Prius Prime

4 cyl. 1.8 Hybrid	VO-40 ^{X905}			
-------------------	-----------------------	--	--	--

	VO-102 ^{Z905}	VA-344	VCA-2035	NS ⁴³⁷
--	------------------------	--------	----------	-------------------

Prius V

4 cyl. 1.8L Hybrid	VO-40 ^{X905}			
--------------------	-----------------------	--	--	--

	VO-102 ^{Z905}	VA-257	VCA-1031	NS ⁴³⁷
--	------------------------	--------	----------	-------------------

RAV4

4 cyl. 2.5L	VO-84	VA-309	VCA-1031	NS ⁴³⁷
-------------	-------	--------	----------	-------------------

4 cyl. 2.5L Hybrid	VO-84	VA-257	VCA-1031	NS ⁴³⁷
--------------------	-------	--------	----------	-------------------

Sequoia

V8 5.7L	VO-96	VA-440	VCA-1031	NS ⁴³⁷
---------	-------	--------	----------	-------------------

Sienna

V6 3.5L	VO-84	VA-273	VCA-1031	NS ⁴³⁷
---------	-------	--------	----------	-------------------

Tacoma

4 cyl 2.7L	VO-25	VA-248	VCA-1037	NS ⁴³⁷
------------	-------	--------	----------	-------------------

V6 3.5L	VO-84	VA-440	VCA-1037	NS ⁴³⁷
---------	-------	--------	----------	-------------------

Tundra

V8 4.6L	VO-96	VA-440	VCA-1031	NS ⁴³⁷
---------	-------	--------	----------	-------------------

V8 5.7L	VO-96	VA-440	VCA-1031	NS ⁴³⁷
---------	-------	--------	----------	-------------------

Se reporter à table de matière pour les notes en bas de page en français. Utilize el contenido para ver notas a pie.

NS - Non-Serviceable / Non réparable / No reparable LF - Life-Time Filter / Filtro para toda la vida / Filtre à vie

⁴³⁷ Requires replacement of the complete fuel pump/fuel filter module. ^{X905}Spin-on filter ^{X967}Cartridge filter ^{Z905}Cartridge filter ^{Z967}Spin-on filter



TOYOTA (cont'd)

	Oil	Air	Cabin*	Fuel
2018				
Yaris iA				
4 cyl. 1.5	VO-106			NS ⁴³⁷
Yaris				
4 cyl. 1.5 (P5)	VO-106			NS ⁴³⁷
4 cyl 1.5L (1NZFE)	VO-40	VA-231	VCA-1031	NS ⁴³⁷
2017				
4-Runner				
V6 4.0L	VO-87	VA-256	VCA-1031	NS ⁴³⁷
86				
4 cyl. 2.0L	VO-113	VA-171	VCA-1110	NS ⁴³⁷
Avalon				
4 cyl. 2.5L Hybrid	VO-84	VA-309	VCA-1031	NS ⁴³⁷
V6 3.5L	VO-84	VA-273	VCA-1031	NS ⁴³⁷
Camry				
4 cyl 2.5L	VO-84	VA-214	VCA-1031	NS ⁴³⁷
4 cyl 2.5L Hybrid	VO-84	VA-309	VCA-1031	NS ⁴³⁷
V6 3.5L	VO-84	VA-273	VCA-1031	NS ⁴³⁷
Corolla				
4 cyl. 1.8L	VO-40 ^{X905} VO-102 ^{Z905}	VA-231	VCA-1031	NS ⁴³⁷
Corolla iM				
4 cyl. 1.8L	VO-40	VA-231	VCA-1031	NS ⁴³⁷
Highlander				
4 cyl 2.7L	VO-84	VA-273	VCA-1031	NS ⁴³⁷
V6 3.5L GAS	VO-84	VA-273	VCA-1031	NS ⁴³⁷
V6 3.5L Hybrid	VO-84		VCA-1031	NS ⁴³⁷
Land Cruiser				
V8 5.7L	VO-96	VA-234	VCA-1031	NS ⁴³⁷
Mirai				
-- Electric/Hydrogen			VCA-1031	
Prius				
4 cyl. 1.8L Hybrid	VO-40 ^{X905} VO-102 ^{Z905}	VA-344	VCA-2035	NS ⁴³⁷
Prius C				
4 cyl. 1.5L Hybrid	VO-40	VA-344	VCA-1031	NS ⁴³⁷
Prius Prime				
4 cyl. 1.8 Hybrid	VO-40 ^{X905} VO-102 ^{Z905}	VA-344	VCA-2035	NS ⁴³⁷
Prius V				
4 cyl. 1.8L Hybrid	VO-40 ^{X905} VO-102 ^{Z905}	VA-257	VCA-1031	NS ⁴³⁷
RAV4				
4 cyl. 2.5L	VO-84	VA-309	VCA-1031	NS ⁴³⁷
4 cyl. 2.5L Hybrid	VO-84	VA-257	VCA-1031	NS ⁴³⁷
Sequoia				
V8 5.7L	VO-96	VA-440	VCA-1031	NS ⁴³⁷
Sienna				
V6 3.5L	VO-84	VA-273	VCA-1031	NS ⁴³⁷
Tacoma				
4 cyl 2.7L	VO-25	VA-248	VCA-1037	NS ⁴³⁷
V6 3.5L	VO-84	VA-440	VCA-1037	NS ⁴³⁷

Se reporter à table de matière pour les notes en bas de page en français. Utilize el contenido para ver notas a pie.

NS - Non-Serviceable / Non réparable / No repairable LF - Life-Time Filter / Filtro para toda la vida / Filtre à vie

⁴³⁷ Requires replacement of the complete fuel pump/fuel filter module. ^{X905}Spin-on filter ^{Z905}Cartridge filter



TOYOTA (cont'd)

2017

Tundra

V8 4.6L	VO-96	VA-440	VCA-1031	NS ⁴³⁷
V8 5.7L	VO-96	VA-440	VCA-1031	NS ⁴³⁷

Yaris iA

4 cyl. 1.5	VO-106			NS ⁴³⁷
------------	--------	--	--	-------------------

Yaris

4 cyl. 1.5 (P5)	VO-106			NS ⁴³⁷
4 cyl 1.5L (1NZFE)	VO-40	VA-231	VCA-1031	NS ⁴³⁷

2016

4-Runner

V6 4.0L	VO-87	VA-256	VCA-1031	NS ⁴³⁷
---------	-------	--------	----------	-------------------

Avalon

4 cyl. 2.5L Hybrid	VO-84	VA-309	VCA-1031	NS ⁴³⁷
V6 3.5L	VO-84	VA-273	VCA-1031	NS ⁴³⁷

Camry

4 cyl 2.5L	VO-84	VA-214	VCA-1031	NS ⁴³⁷
4 cyl 2.5L Hybrid	VO-84	VA-309	VCA-1031	NS ⁴³⁷
V6 3.5L	VO-84	VA-273	VCA-1031	NS ⁴³⁷

Corolla

4 cyl. 1.8L	VO-40 ^{X905} VO-102 ^{Z905}	VA-231	VCA-1031	NS ⁴³⁷
-------------	---	--------	----------	-------------------

Highlander

4 cyl 2.7L	VO-84	VA-273	VCA-1031	NS ⁴³⁷
V6 3.5L GAS	VO-84	VA-273	VCA-1031	NS ⁴³⁷
V6 3.5L Hybrid	VO-84	VA-179	VCA-1031	NS ⁴³⁷

Land Cruiser

V8 5.7L	VO-96	VA-234	VCA-1031	NS ⁴³⁷
---------	-------	--------	----------	-------------------

Mirai

-- Electric/Hydrogen			VCA-1031	
----------------------	--	--	----------	--

Prius

4 cyl. 1.8L Hybrid	VO-102	VA-344	VCA-2035	NS ⁴³⁷
--------------------	--------	--------	----------	-------------------

Prius C

4 cyl. 1.5L Hybrid	VO-40	VA-344	VCA-1031	NS ⁴³⁷
--------------------	-------	--------	----------	-------------------

Prius V

4 cyl. 1.8L Hybrid	VO-102	VA-257	VCA-1031	NS ⁴³⁷
--------------------	--------	--------	----------	-------------------

RAV4

4 cyl. 2.5L FI (2ARFE)	VO-84	VA-309	VCA-1031	NS ⁴³⁷
4 cyl. 2.5L FI (Hybrid)	VO-84	VA-257	VCA-1031	NS ⁴³⁷

Sequoia

V8 5.7L	VO-96	VA-440	VCA-1031	NS ⁴³⁷
---------	-------	--------	----------	-------------------

Sienna

V6 3.5L	VO-84	VA-273	VCA-1031	NS ⁴³⁷
---------	-------	--------	----------	-------------------

Tacoma

4 cyl 2.7L	VO-25	VA-248	VCA-1037	NS ⁴³⁷
V6 3.5L	VO-84	VA-440	VCA-1037	NS ⁴³⁷

Tundra

V8 4.6L	VO-96	VA-440	VCA-1031	NS ⁴³⁷
V8 5.7L	VO-96	VA-440	VCA-1031	NS ⁴³⁷

Venza

4 cyl 2.7L FI (1ARFE)	VO-84	VA-214	VCA-1031	NS ⁴³⁷
V6 3.5L FI (2GRFE)	VO-84	VA-209	VCA-1031	NS ⁴³⁷

Se reporter à table de matière pour les notes en bas de page en français. Utilize el contenido para ver notas a pie.

NS - Non-Serviceable / Non réparable / No reparable LF - Life-Time Filter / Filtro para toda la vida / Filtre à vie

⁴³⁷ Requires replacement of the complete fuel pump/fuel filter module. ^{X905}Spin-on filter ^{Z905}Cartridge filter



TOYOTA (cont'd)

	Oil	Air	Cabin*	Fuel
2016				
Yaris				
4 cyl. 1.5 (P5)	VO-106			NS ⁴³⁷
4 cyl 1.5L (1NZFE)	VO-40	VA-231	VCA-1031	NS ⁴³⁷
2015				
4-Runner				
V6 4.0L	VO-87	VA-256	VCA-1031	NS ⁴³⁷
Avalon				
4 cyl. 2.5L Hybrid	VO-84	VA-309	VCA-1031	NS ⁴³⁷
V6 3.5L	VO-84	VA-273	VCA-1031	NS ⁴³⁷
Camry				
4 cyl 2.5L FI (2ARFE)	VO-84	VA-214	VCA-1031	NS ⁴³⁷
4 cyl 2.5L FI (Hybrid)	VO-84	VA-309	VCA-1031	NS ⁴³⁷
V6 3.5L FI (2GRFE)	VO-84	VA-273	VCA-1031	NS ⁴³⁷
Corolla				
4 cyl. 1.8L	VO-102	VA-231	VCA-1031	NS ⁴³⁷
Highlander				
4 cyl 2.7L	VO-84	VA-273	VCA-1031	NS ⁴³⁷
V6 3.5L GAS	VO-84	VA-273	VCA-1031	NS ⁴³⁷
V6 3.5L Hybrid	VO-84	VA-179	VCA-1031	NS ⁴³⁷
Land Cruiser				
V8 5.7L	VO-96	VA-234	VCA-1031	NS ⁴³⁷
Prius				
4 cyl. 1.8L Hybrid	VO-102	VA-257	VCA-1031	NS ⁴³⁷
Prius C				
4 cyl. 1.5L Hybrid	VO-40	VA-344	VCA-1031	NS ⁴³⁷
Prius V				
4 cyl. 1.8L Hybrid	VO-102	VA-257	VCA-1031	NS ⁴³⁷
RAV4				
4 cyl. 2.5L FI (2ARFE)	VO-84	VA-309	VCA-1031	NS ⁴³⁷
Sequoia				
V8 5.7L	VO-96	VA-440	VCA-1031	NS ⁴³⁷
Sienna				
V6 3.5L	VO-84	VA-273	VCA-1031	NS ⁴³⁷
Tacoma				
4 cyl 2.7L	VO-25	VA-248	VCA-1037	NS ⁴³⁷
V6 4.0L	VO-25	VA-195	VCA-1037	NS ⁴³⁷
Tundra				
V8 4.6L	VO-96	VA-440	VCA-1031	NS ⁴³⁷
V8 5.7L	VO-96	VA-440	VCA-1031	NS ⁴³⁷
Venza				
4 cyl 2.7L FI (1ARFE)	VO-84	VA-214	VCA-1031	NS ⁴³⁷
V6 3.5L FI (2GRFE)	VO-84	VA-209	VCA-1031	NS ⁴³⁷
Yaris				
4 cyl 1.5L (1NZFE)	VO-40	VA-231	VCA-1031	NS ⁴³⁷
2014				
4-Runner				
V6 4.0L	VO-87	VA-256	VCA-1031	NS ⁴³⁷
Avalon				
4 cyl. 2.5L Hybrid	VO-84	VA-309	VCA-1031	NS ⁴³⁷
V6 3.5L	VO-84	VA-273	VCA-1031	NS ⁴³⁷
Camry				
4 cyl 2.5L FI (2ARFE)	VO-84	VA-214	VCA-1031	NS ⁴³⁷

Se reporter à table de matière pour les notes en bas de page en français. Utilize el contenido para ver notas a pie.

NS - Non-Serviceable / Non réparable / No reparable LF - Life-Time Filter / Filtro para toda la vida / Filtre à vie

⁴³⁷ Requires replacement of the complete fuel pump/fuel filter module.



TOYOTA (cont'd)

2014

Camry

4 cyl 2.5L FI (Hybrid)	VO-84	VA-309	VCA-1031	NS ⁴³⁷
V6 3.5L FI (2GRFE)	VO-84	VA-273	VCA-1031	NS ⁴³⁷

Corolla

4 cyl. 1.8L	VO-102	VA-231 ^{x891} VA-209 ^{z891}	VCA-1031	NS ⁴³⁷
-------------	--------	--	----------	-------------------

FJ Cruiser

V6 4.0L	VO-87	VA-256	VCA-1014 ¹¹³⁴	NS ⁴³⁷
---------	-------	--------	--------------------------	-------------------

Highlander

4 cyl 2.7L	VO-84	VA-273	VCA-1031	NS ⁴³⁷
V6 3.5L GAS	VO-84	VA-273	VCA-1031	NS ⁴³⁷
V6 3.5L Hybrid	VO-84	VA-179	VCA-1031	NS ⁴³⁷

Land Cruiser

V8 5.7L	VO-96	VA-234	VCA-1031	NS ⁴³⁷
---------	-------	--------	----------	-------------------

Matrix

4 cyl. 1.8L FI (2ZRFE)	VO-102	VA-231	VCA-1031	NS ⁴³⁷
------------------------	--------	--------	----------	-------------------

Prius

4 cyl. 1.8L Hybrid	VO-102	VA-257	VCA-1031	NS ⁴³⁷
--------------------	--------	--------	----------	-------------------

Prius C

4 cyl. 1.5L Hybrid	VO-40	VA-344	VCA-1031	NS ⁴³⁷
--------------------	-------	--------	----------	-------------------

Prius V

4 cyl. 1.8L Hybrid	VO-102	VA-257	VCA-1031	NS ⁴³⁷
--------------------	--------	--------	----------	-------------------

RAV4

Electric			VCA-1031	
4 cyl. 2.5L FI (2ARFE)	VO-84	VA-309	VCA-1031	NS ⁴³⁷

Sequoia

V8 5.7L	VO-96	VA-440	VCA-1031	NS ⁴³⁷
---------	-------	--------	----------	-------------------

Sienna

V6 3.5L	VO-84	VA-273	VCA-1031	NS ⁴³⁷
---------	-------	--------	----------	-------------------

Tacoma

4 cyl 2.7L	VO-25	VA-248	VCA-1037	NS ⁴³⁷
V6 4.0L	VO-25	VA-195	VCA-1037	NS ⁴³⁷

Tundra

V6 4.0L	VO-87	VA-234	VCA-1031	NS ⁴³⁷
V8 4.6L	VO-96	VA-440	VCA-1031	NS ⁴³⁷
V8 5.7L	VO-96	VA-440	VCA-1031	NS ⁴³⁷

Venza

4 cyl 2.7L FI (1ARFE)	VO-84	VA-214	VCA-1031	NS ⁴³⁷
V6 3.5L FI (2GRFE)	VO-84	VA-209	VCA-1031	NS ⁴³⁷

Yaris

4 cyl 1.5L (1NZFE)	VO-40	VA-231	VCA-1031	NS ⁴³⁷
--------------------	-------	--------	----------	-------------------

2013

4-Runner

V6 4.0L	VO-87	VA-256	VCA-1031	NS ⁴³⁷
---------	-------	--------	----------	-------------------

Avalon

4 cyl. 2.5L Hybrid	VO-84	VA-309	VCA-1031	NS ⁴³⁷
V6 3.5L	VO-84	VA-273	VCA-1031	NS ⁴³⁷

Camry

4 cyl 2.5L FI (2ARFE)	VO-84	VA-214	VCA-1031	NS ⁴³⁷
4 cyl 2.5L FI (Hybrid)	VO-84	VA-309	VCA-1031	NS ⁴³⁷
V6 3.5L FI (2GRFE)	VO-84	VA-273	VCA-1031	NS ⁴³⁷

Se reporter à table de matière pour les notes en bas de page en français. Utilize el contenido para ver notas a pie.

NS - Non-Serviceable / Non réparable / No reparable LF - Life-Time Filter / Filtro para toda la vida / Filtre à vie

⁴³⁷ Requires replacement of the complete fuel pump/fuel filter module. ¹¹³⁴Dust Filter. Replace with VCA-1032 when stock is depleted. ^{x891}4 sided filter ^{z891}5 sided filter



TOYOTA (cont'd)

	Oil	Air	Cabin*	Fuel
2013				
Corolla				
4 cyl. 1.8L	VO-102	VA-231	VCA-1031	NS ⁴³⁷
FJ Cruiser				
V6 4.0L	VO-87	VA-256	VCA-1014 ¹¹³⁴	NS ⁴³⁷
Highlander				
4 cyl. 2.7L	VO-84	VA-163	VCA-1031	NS ⁴³⁷
V6 3.5L GAS	VO-84	VA-163	VCA-1031	NS ⁴³⁷
V6 3.5L Hybrid	VO-84	VA-179	VCA-1031	NS ⁴³⁷
Land Cruiser				
V8 5.7L	VO-96	VA-234	VCA-1031	NS ⁴³⁷
Matrix				
4 cyl. 1.8L FI (2ZRFE)	VO-102	VA-231	VCA-1031	NS ⁴³⁷
4 cyl. 2.4L FI (2AZFE)	VO-40	VA-209	VCA-1031	NS ⁴³⁷
Prius				
4 cyl. 1.8L Hybrid	VO-102	VA-257	VCA-1031	NS ⁴³⁷
Prius C				
4 cyl. 1.5L Hybrid	VO-40	VA-344	VCA-1031	NS ⁴³⁷
Prius V				
4 cyl. 1.8L Hybrid	VO-102	VA-257	VCA-1031	NS ⁴³⁷
RAV4				
Electric			VCA-1031	
4 cyl. 2.5L FI (2ARFE)	VO-84	VA-309	VCA-1031	NS ⁴³⁷
Sequoia				
V8 5.7L	VO-96	VA-234	VCA-1031	NS ⁴³⁷
Sienna				
4 cyl. 2.7L	VO-84	VA-273	VCA-1031	NS ⁴³⁷
V6 3.5L	VO-84	VA-273	VCA-1031	NS ⁴³⁷
Tacoma				
4 cyl. 2.7L	VO-25	VA-248	VCA-1037	NS ⁴³⁷
V6 4.0L	VO-25	VA-195	VCA-1037	NS ⁴³⁷
Tundra				
V6 4.0L	VO-87	VA-234	VCA-1031	NS ⁴³⁷
V8 4.6L	VO-96	VA-234	VCA-1031	NS ⁴³⁷
V8 5.7L	VO-96	VA-234	VCA-1031	NS ⁴³⁷
Venza				
4 cyl. 2.7L FI (1ARFE)	VO-84	VA-214	VCA-1031	NS ⁴³⁷
V6 3.5L FI (2GRFE)	VO-84	VA-209	VCA-1031	NS ⁴³⁷
Yaris				
4 cyl. 1.5L (1NZFE)	VO-40	VA-231	VCA-1031	NS ⁴³⁷
2012				
4-Runner				
V6 4.0L	VO-87	VA-256	VCA-1031	NS ⁴³⁷
Avalon				
V6 3.5L FI (2GRFE)	VO-84	VA-209	VCA-1031	NS ⁴³⁷
Camry				
4 cyl. 2.5L FI (2ARFE)	VO-84	VA-214	VCA-1031	NS ⁴³⁷
4 cyl. 2.5L FI (Hybrid)	VO-84	VA-309	VCA-1031	NS ⁴³⁷
V6 3.5L FI (2GRFE)	VO-84	VA-273	VCA-1031	NS ⁴³⁷
Corolla				
4 cyl. 1.8L	VO-102	VA-231	VCA-1031	NS ⁴³⁷
4 cyl. 2.4L	VO-40	VA-209	VCA-1031	NS ⁴³⁷

Se reporter à table de matière pour les notes en bas de page en français. Utilize el contenido para ver notas a pie.

NS - Non-Serviceable / Non réparable / No repairable LF - Life-Time Filter / Filtro para toda la vida / Filtre à vie

⁴³⁷ Requires replacement of the complete fuel pump/fuel filter module. ¹¹³⁴Dust Filter. Replace with VCA-1032 when stock is depleted.



TOYOTA (cont'd)

2012

FJ Cruiser

V6 4.0L	VO-87	VA-256	VCA-1014 ¹¹³⁴	NS ⁴³⁷
---------	-------	--------	--------------------------	-------------------

Highlander

4 cyl 2.7L	VO-84	VA-163	VCA-1031	NS ⁴³⁷
V6 3.5L FI (2GRFE)	VO-84	VA-163	VCA-1031	NS ⁴³⁷
V6 3.5L Hybrid	VO-84	VA-179	VCA-1031	NS ⁴³⁷

Matrix

4 cyl. 1.8L FI (2ZRFE)	VO-102	VA-231	VCA-1031	NS ⁴³⁷
4 cyl. 2.4L FI (2AZFE)	VO-40	VA-209	VCA-1031	NS ⁴³⁷

Prius

4 cyl. 1.8L Hybrid	VO-102	VA-257	VCA-1031	NS ⁴³⁷
--------------------	--------	--------	----------	-------------------

Prius C

4 cyl. 1.5L Hybrid	VO-40	VA-344	VCA-1031	NS ⁴³⁷
--------------------	-------	--------	----------	-------------------

Prius V

4 cyl. 1.8L Hybrid	VO-102	VA-257	VCA-1031	NS ⁴³⁷
--------------------	--------	--------	----------	-------------------

RAV4

4 cyl. 2.5L FI (2ARFE)	VO-84	VA-209	VCA-1031	NS ⁴³⁷
V6 3.5L FI (2GRFE)	VO-84	VA-209	VCA-1031	NS ⁴³⁷

Sequoia

V8 4.6L	VO-96	VA-234	VCA-1031	NS ⁴³⁷
V8 5.7L	VO-96	VA-234	VCA-1031	NS ⁴³⁷

Sienna

4 cyl. 2.7L	VO-84	VA-273	VCA-1031	NS ⁴³⁷
V6 3.5L	VO-84	VA-273	VCA-1031	NS ⁴³⁷

Tacoma

4 cyl 2.7L	VO-25	VA-248	VCA-1037	NS ⁴³⁷
V6 4.0L	VO-25	VA-195	VCA-1037	NS ⁴³⁷

Tundra

V6 4.0L	VO-87	VA-234	VCA-1031	NS ⁴³⁷
V8 4.6L	VO-96	VA-234	VCA-1031	NS ⁴³⁷
V8 5.7L	VO-96	VA-234	VCA-1031	NS ⁴³⁷

Venza

4 cyl 2.7L FI (1ARFE)	VO-84	VA-214	VCA-1031	NS ⁴³⁷
V6 3.5L FI (2GRFE)	VO-84	VA-209	VCA-1031	NS ⁴³⁷

Yaris

4 cyl 1.5L (1NZFE)	VO-40	VA-231	VCA-1031	NS ⁴³⁷
--------------------	-------	--------	----------	-------------------

2011

4-Runner

V6 4.0L	VO-87	VA-256	VCA-1031	NS ⁴³⁷
---------	-------	--------	----------	-------------------

Avalon

V6 3.5L FI (2GRFE)	VO-84	VA-209	VCA-1031	NS ⁴³⁷
--------------------	-------	--------	----------	-------------------

Camry

4 cyl 2.4L FI (Hybrid)	VO-40	VA-163	VCA-1031	NS ⁴³⁷
4 cyl 2.5L FI (2ARFE)	VO-84	VA-214	VCA-1031	NS ⁴³⁷
V6 3.5L FI (2GRFE)	VO-84	VA-209	VCA-1031	NS ⁴³⁷

Corolla

4 cyl. 1.8L FI (2ZRFE)	VO-102	VA-231	VCA-1031	NS ⁴³⁷
4 cyl. 2.4L FI (2AZFE)	VO-40	VA-209	VCA-1031	NS ⁴³⁷

FJ Cruiser

V6 4.0L	VO-87	VA-256	VCA-1014 ¹¹³⁴	NS ⁴³⁷
---------	-------	--------	--------------------------	-------------------

Highlander

4 cyl 2.7L FI (1ARFE)	VO-84	VA-163	VCA-1031	NS ⁴³⁷
-----------------------	-------	--------	----------	-------------------

Se reporter à table de matière pour les notes en bas de page en français. Utilize el contenido para ver notas a pie.

NS - Non-Serviceable / Non réparable / No reparable LF - Life-Time Filter / Filtro para toda la vida / Filtre à vie

⁴³⁷ Requires replacement of the complete fuel pump/fuel filter module. ¹¹³⁴Dust Filter. Replace with VCA-1032 when stock is depleted.



TOYOTA (cont'd)

	Oil	Air	Cabin*	Fuel
2011				
Highlander				
V6 3.5L FI (2GRFE)	VO-84	VA-163	VCA-1031	NS ⁴³⁷
V6 3.5L FI (Hybrid)	VO-84	VA-179	VCA-1031	NS ⁴³⁷
Land Cruiser				
V8 5.7L	VO-96	VA-234	VCA-1031	NS ⁴³⁷
Matrix				
4 cyl. 1.8L FI (2ZRFE)	VO-102	VA-231	VCA-1031	NS ⁴³⁷
4 cyl. 2.4L FI (2AZFE)	VO-40	VA-209	VCA-1031	NS ⁴³⁷
Prius				
4 cyl. 1.8L Hybrid	VO-102	VA-257	VCA-1031	NS ⁴³⁷
RAV4				
4 cyl. 2.5L FI (2ARFE)	VO-84	VA-209	VCA-1031	NS ⁴³⁷
V6 3.5L FI (2GRFE)	VO-84	VA-209	VCA-1031	NS ⁴³⁷
Sequoia				
V8 4.6L	VO-96	VA-234	VCA-1031	NS ⁴³⁷
V8 5.7L	VO-96	VA-234	VCA-1031	NS ⁴³⁷
Sienna				
4 cyl. 2.7L	VO-84	VA-273	VCA-1031	NS ⁴³⁷
V6 3.5L	VO-84	VA-273	VCA-1031	NS ⁴³⁷
Tacoma				
4 cyl 2.7L	VO-25	VA-248	VCA-1037	NS ⁴³⁷
V6 4.0L	VO-25	VA-195	VCA-1037	NS ⁴³⁷
Tundra				
V6 4.0L	VO-25 ^{X494} VO-87 ^{Z494}	VA-234	VCA-1031	NS ⁴³⁷
V8 4.6L	VO-96	VA-234	VCA-1031	NS ⁴³⁷
V8 5.7L	VO-96	VA-234	VCA-1031	NS ⁴³⁷
Venza				
4 cyl 2.7L FI (1ARFE)	VO-84	VA-214	VCA-1031	NS ⁴³⁷
V6 3.5L FI (2GRFE)	VO-84	VA-209	VCA-1031	NS ⁴³⁷
Yaris				
4 cyl 1.5L (1NZFE)	VO-40	VA-231	VCA-1031	NS ⁴³⁷
2010				
4-Runner				
4 cyl. 2.7L	VO-25	VA-146	VCA-1031	NS ⁴³⁷
V6 4.0L	VO-87	VA-256	VCA-1031	NS ⁴³⁷
Avalon				
V6 3.5L FI (2GRFE)	VO-84	VA-209	VCA-1031	NS ⁴³⁷
Camry				
4 cyl 2.4L FI (Hybrid)	VO-40	VA-163	VCA-1031	NS ⁴³⁷
4 cyl 2.5L FI (2ARFE)	VO-84	VA-214	VCA-1031	NS ⁴³⁷
V6 3.5L FI (2GRFE)	VO-84	VA-209	VCA-1031	NS ⁴³⁷
Corolla				
4 cyl. 1.8L FI (2ZRFE)	VO-102	VA-231	VCA-1031	NS ⁴³⁷
4 cyl. 2.4L FI (2AZFE)	VO-40	VA-209	VCA-1031	NS ⁴³⁷
FJ Cruiser				
V6 4.0L	VO-87	VA-256	VCA-1014 ¹¹³⁴	NS ⁴³⁷
Highlander				
4 cyl 2.7L FI (1ARFE)	VO-84	VA-163	VCA-1031	NS ⁴³⁷
V6 3.3L FI (Hybrid)	VO-25	VA-353	VCA-1031	NS ⁴³⁷
V6 3.5L FI (2GRFE)	VO-84	VA-163	VCA-1031	NS ⁴³⁷

Se reporter à table de matière pour les notes en bas de page en français. Utilize el contenido para ver notas a pie.

NS - Non-Serviceable / Non réparable / No repairable LF - Life-Time Filter / Filtro para toda la vida / Filtre à vie

⁴³⁷ Requires replacement of the complete fuel pump/fuel filter module. ¹¹³⁴Dust Filter. Replace with VCA-1032 when stock is depleted. ^{X494}Spin-on Filter.

^{Z494}Cartridge Filter.



TOYOTA (cont'd)

2010

Land Cruiser

V8 5.7L	VO-96	VA-234	VCA-1031	NS ⁴³⁷
---------	-------	--------	----------	-------------------

Matrix

4 cyl. 1.8L FI (2ZRFE)	VO-102	VA-231	VCA-1031	NS ⁴³⁷
------------------------	--------	--------	----------	-------------------

4 cyl. 2.4L FI (2AZFE)	VO-40	VA-209	VCA-1031	NS ⁴³⁷
------------------------	-------	--------	----------	-------------------

Prius

4 cyl. 1.8L Hybrid	VO-102	VA-257	VCA-1031	NS ⁴³⁷
--------------------	--------	--------	----------	-------------------

RAV4

4 cyl. 2.5L FI (2ARFE)	VO-84	VA-209	VCA-1031	NS ⁴³⁷
------------------------	-------	--------	----------	-------------------

V6 3.5L FI (2GRFE)	VO-84	VA-209	VCA-1031	NS ⁴³⁷
--------------------	-------	--------	----------	-------------------

Sequoia

V8 4.6L	VO-96	VA-234	VCA-1031	NS ⁴³⁷
---------	-------	--------	----------	-------------------

V8 5.7L	VO-96	VA-234	VCA-1031	NS ⁴³⁷
---------	-------	--------	----------	-------------------

Sienna

V6 3.5L	VO-84	VA-163	VCA-1014 ¹¹³⁴	NS ⁴³⁷
---------	-------	--------	--------------------------	-------------------

Tacoma

4 cyl 2.7L	VO-25	VA-248	VCA-1037	NS ⁴³⁷
------------	-------	--------	----------	-------------------

V6 4.0L	VO-25	VA-195	VCA-1037	NS ⁴³⁷
---------	-------	--------	----------	-------------------

Tundra

V6 4.0L	VO-25	VA-195	VCA-1031	NS ⁴³⁷
---------	-------	--------	----------	-------------------

V8 4.6L	VO-96	VA-234	VCA-1031	NS ⁴³⁷
---------	-------	--------	----------	-------------------

V8 5.7L	VO-96	VA-234	VCA-1031	NS ⁴³⁷
---------	-------	--------	----------	-------------------

Venza

4 cyl 2.7L FI (1ARFE)	VO-84	VA-214	VCA-1031	NS ⁴³⁷
-----------------------	-------	--------	----------	-------------------

V6 3.5L FI (2GRFE)	VO-84	VA-209	VCA-1031	NS ⁴³⁷
--------------------	-------	--------	----------	-------------------

Yaris

4 cyl 1.5L (1NZFE)	VO-40	VA-231	VCA-1031	NS ⁴³⁷
--------------------	-------	--------	----------	-------------------

2009

4-Runner

V6 4.0L FI (1GRFE)	VO-25	VA-195	VCA-1014 ¹¹³⁴	NS ⁴³⁷
--------------------	-------	--------	--------------------------	-------------------

V8 4.7L FI (2UZFE)	VO-25	VA-146	VCA-1014 ¹¹³⁴	NS ⁴³⁷
--------------------	-------	--------	--------------------------	-------------------

Avalon

V6 3.5L FI (2GRFE)	VO-84	VA-209	VCA-1031	NS ⁴³⁷
--------------------	-------	--------	----------	-------------------

Camry

4 cyl 2.4L FI (2AZFE)	VO-40	VA-214	VCA-1031	NS ⁴³⁷
-----------------------	-------	--------	----------	-------------------

4 cyl 2.4L FI (Hybrid)	VO-40	VA-163	VCA-1031	NS ⁴³⁷
------------------------	-------	--------	----------	-------------------

V6 3.5L FI (2GRFE)	VO-84	VA-209	VCA-1031	NS ⁴³⁷
--------------------	-------	--------	----------	-------------------

Corolla

4 cyl. 1.8L FI (2ZRFE)	VO-102	VA-231	VCA-1031	NS ⁴³⁷
------------------------	--------	--------	----------	-------------------

4 cyl. 2.4L FI (2AZFE)	VO-40	VA-209	VCA-1031	NS ⁴³⁷
------------------------	-------	--------	----------	-------------------

FJ Cruiser

V6 4.0L	VO-25	VA-195	VCA-1014 ¹¹³⁴	NS ⁴³⁷
---------	-------	--------	--------------------------	-------------------

Highlander

4 cyl 2.7L FI (1ARFE)	VO-84	VA-163	VCA-1031	NS ⁴³⁷
-----------------------	-------	--------	----------	-------------------

V6 3.3L FI (Hybrid)	VO-25	VA-353	VCA-1031	NS ⁴³⁷
---------------------	-------	--------	----------	-------------------

V6 3.5L FI (2GRFE)	VO-84	VA-163	VCA-1031	NS ⁴³⁷
--------------------	-------	--------	----------	-------------------

Land Cruiser

V8 5.7L	VO-96	VA-234	VCA-1031	NS ⁴³⁷
---------	-------	--------	----------	-------------------

Matrix

4 cyl. 1.8L FI (2ZRFE)	VO-102	VA-231	VCA-1031	NS ⁴³⁷
------------------------	--------	--------	----------	-------------------

4 cyl. 2.4L FI (2AZFE)	VO-40	VA-209	VCA-1031	NS ⁴³⁷
------------------------	-------	--------	----------	-------------------

Se reporter à table de matière pour les notes en bas de page en français. Utilize el contenido para ver notas a pie.

NS - Non-Serviceable / Non réparable / No reparable LF - Life-Time Filter / Filtro para toda la vida / Filtre à vie

⁴³⁷ Requires replacement of the complete fuel pump/fuel filter module. ¹¹³⁴Dust Filter. Replace with VCA-1032 when stock is depleted.



TOYOTA (cont'd)

	Oil	Air	Cabin*	Fuel
2009				
Prius				
4 cyl. 1.5L FI (Hybrid)	VO-40	VA-251	VCA-1014 ¹¹³⁴	NS ⁴³⁷
RAV4				
4 cyl. 2.5L FI (2ARFE)	VO-84	VA-209	VCA-1031	NS ⁴³⁷
V6 3.5L FI (2GRFE)	VO-84	VA-209	VCA-1031	NS ⁴³⁷
Sequoia				
V8 4.7L FI (2UZFE)	VO-25	VA-234	VCA-1031	NS ⁴³⁷
V8 5.7L FI	VO-96	VA-234	VCA-1031	NS ⁴³⁷
Sienna				
V6 3.5L FI (2GRFE)	VO-84	VA-163	VCA-1014 ¹¹³⁴	NS ⁴³⁷
Tacoma				
4 cyl. 2.7L FI (2TRFE)	VO-25	VA-248	VCA-1037	NS ⁴³⁷
V6 4.0L FI (1GRFE)	VO-25	VA-195	VCA-1037	NS ⁴³⁷
Tundra				
V6 4.0L FI (1GRFE)	VO-25	VA-195	VCA-1031	NS ⁴³⁷
V8 4.7L FI (2UZFE)	VO-25	VA-234	VCA-1031	NS ⁴³⁷
V8 5.7L FI	VO-96	VA-234	VCA-1031	NS ⁴³⁷
Venza				
4 cyl. 2.7L FI (1ARFE)	VO-84	VA-214	VCA-1031	NS ⁴³⁷
V6 3.5L FI (2GRFE)	VO-84	VA-209	VCA-1031	NS ⁴³⁷
Yaris				
4 cyl. 1.5L (1NZFE)	VO-40	VA-231	VCA-1031	NS ⁴³⁷
2008				
4-Runner				
V6 4.0L FI (1GRFE)	VO-25	VA-195	VCA-1014 ¹¹³⁴	NS ⁴³⁷
V8 4.7L FI (2UZFE)	VO-25	VA-146	VCA-1014 ¹¹³⁴	NS ⁴³⁷
Avalon				
V6 3.5L FI (2GRFE)	VO-84	VA-209	VCA-1031	NS ⁴³⁷
Camry				
4 cyl. 2.4L FI (2AZFE)	VO-40	VA-214	VCA-1031	NS ⁴³⁷
4 cyl. 2.4L FI (Hybrid)	VO-40	VA-163	VCA-1031	NS ⁴³⁷
V6 3.5L FI (2GRFE)	VO-84	VA-209	VCA-1031	NS ⁴³⁷
Corolla				
4 cyl. 1.8L FI (1ZZFE)	VO-40	VA-171	VCA-1028	NS ⁴³⁷
FJ Cruiser				
V6 4.0L	VO-25	VA-195	VCA-1014 ¹¹³⁴	NS ⁴³⁷
Highlander				
V6 3.3L FI (Hybrid)	VO-25	VA-353	VCA-1031	NS ⁴³⁷
V6 3.5L FI (2GRFE)	VO-84	VA-163	VCA-1031	NS ⁴³⁷
Land Cruiser				
V8 5.7L	VO-96	VA-234	VCA-1031	NS ⁴³⁷
Matrix				
4 cyl. 1.8L FI (1ZZFE)	VO-40	VA-171	VCA-1028	NS ⁴³⁷
Prius				
4 cyl. 1.5L FI (Hybrid)	VO-40	VA-251	VCA-1014 ¹¹³⁴	NS ⁴³⁷
RAV4				
4 cyl. 2.4L FI (2AZFE)	VO-40	VA-209	VCA-1031	NS ⁴³⁷
V6 3.5L FI (2GRFE)	VO-84	VA-209	VCA-1031	NS ⁴³⁷
Sequoia				
V8 4.7L FI (2UZFE)	VO-25	VA-234	VCA-1031	NS ⁴³⁷
V8 5.7L FI (3URFE)	VO-96	VA-234	VCA-1031	NS ⁴³⁷

Se reporter à table de matière pour les notes en bas de page en français. Utilize el contenido para ver notas a pie.

NS - Non-Serviceable / Non réparable / No reparable LF - Life-Time Filter / Filtro para toda la vida / Filtre à vie

⁴³⁷ Requires replacement of the complete fuel pump/fuel filter module. ¹¹³⁴Dust Filter. Replace with VCA-1032 when stock is depleted.



TOYOTA (cont'd)

2008

Sienna

V6 3.5L FI (2GRFE)	VO-84	VA-163	VCA-1014 ¹¹³⁴	NS ⁴³⁷
--------------------	-------	--------	--------------------------	-------------------

Solara

4 cyl. 2.4L FI (2AZFE)	VO-40	VA-163	VCA-1014 ¹¹³⁴	NS ⁴³⁷
------------------------	-------	--------	--------------------------	-------------------

V6 3.3L FI (3MZFE)	VO-25	VA-163	VCA-1014 ¹¹³⁴	NS ⁴³⁷
--------------------	-------	--------	--------------------------	-------------------

Tacoma

4 cyl 2.7L FI (2TRFE)	VO-25	VA-248	VCA-1037	NS ⁴³⁷
-----------------------	-------	--------	----------	-------------------

V6 4.0L FI (1GRFE)	VO-25	VA-195	VCA-1037	NS ⁴³⁷
--------------------	-------	--------	----------	-------------------

Tundra

V6 4.0L FI (1GRFE)	VO-25	VA-195	VCA-1031	NS ⁴³⁷
--------------------	-------	--------	----------	-------------------

V8 4.7L FI (2UZFE)	VO-25	VA-234	VCA-1031	NS ⁴³⁷
--------------------	-------	--------	----------	-------------------

V8 5.7L FI (3URFE)	VO-96	VA-234	VCA-1031	NS ⁴³⁷
--------------------	-------	--------	----------	-------------------

Yaris

4 cyl 1.5L (1NZFE)	VO-40	VA-231	VCA-1031	NS ⁴³⁷
--------------------	-------	--------	----------	-------------------

2007

4-Runner

V6 4.0L FI (1GRFE)	VO-25	VA-195	VCA-1014 ¹¹³⁴	NS ⁴³⁷
--------------------	-------	--------	--------------------------	-------------------

V8 4.7L FI (2UZFE)	VO-25	VA-146	VCA-1014 ¹¹³⁴	NS ⁴³⁷
--------------------	-------	--------	--------------------------	-------------------

Avalon

V6 3.5L FI (2GRFE)	VO-84	VA-209	VCA-1031	NS ⁴³⁷
--------------------	-------	--------	----------	-------------------

Camry

4 cyl 2.4L FI (2AZFE)	VO-40	VA-214	VCA-1031	NS ⁴³⁷
-----------------------	-------	--------	----------	-------------------

4 cyl 2.4L FI (Hybrid)	VO-40	VA-163	VCA-1031	NS ⁴³⁷
------------------------	-------	--------	----------	-------------------

V6 3.5L FI (2GRFE)	VO-84	VA-209	VCA-1031	NS ⁴³⁷
--------------------	-------	--------	----------	-------------------

Corolla

4 cyl. 1.8L FI (1ZZFE)	VO-40	VA-171	VCA-1028	NS ⁴³⁷
------------------------	-------	--------	----------	-------------------

FJ Cruiser

V6 4.0L	VO-25	VA-195	VCA-1014 ¹¹³⁴	NS ⁴³⁷
---------	-------	--------	--------------------------	-------------------

Highlander

4 cyl. 2.4L FI (2AZFE)	VO-40	VA-163	VCA-1067	NS ⁴³⁷
------------------------	-------	--------	----------	-------------------

V6 3.3L FI (3MZFE)	VO-25	VA-163	VCA-1067	NS ⁴³⁷
--------------------	-------	--------	----------	-------------------

V6 3.3L FI (Hybrid)	VO-25	VA-353	VCA-1067	NS ⁴³⁷
---------------------	-------	--------	----------	-------------------

Land Cruiser

V8 4.7L FI (2UZFE)	VO-25	VA-146		
--------------------	-------	--------	--	--

Matrix

4 cyl. 1.8L FI (1ZZFE)	VO-40	VA-171	VCA-1028	NS ⁴³⁷
------------------------	-------	--------	----------	-------------------

Prius

4 cyl. 1.5L FI (Hybrid)	VO-40	VA-251	VCA-1014 ¹¹³⁴	NS ⁴³⁷
-------------------------	-------	--------	--------------------------	-------------------

RAV4

4 cyl. 2.4L FI (2AZFE)	VO-40	VA-209	VCA-1031	NS ⁴³⁷
------------------------	-------	--------	----------	-------------------

V6 3.5L FI (2GRFE)	VO-84	VA-209	VCA-1031	NS ⁴³⁷
--------------------	-------	--------	----------	-------------------

Sequoia

V8 4.7L FI (2UZFE)	VO-25	VA-146		NS ⁴³⁷
--------------------	-------	--------	--	-------------------

Sienna

V6 3.5L FI (2GRFE)	VO-84	VA-163	VCA-1014 ¹¹³⁴	NS ⁴³⁷
--------------------	-------	--------	--------------------------	-------------------

Solara

4 cyl. 2.4L FI (2AZFE)	VO-40	VA-163	VCA-1014 ¹¹³⁴	NS ⁴³⁷
------------------------	-------	--------	--------------------------	-------------------

V6 3.3L FI (3MZFE)	VO-25	VA-163	VCA-1014 ¹¹³⁴	NS ⁴³⁷
--------------------	-------	--------	--------------------------	-------------------

Tacoma

4 cyl 2.7L FI (2TRFE)	VO-25	VA-248	VCA-1037	NS ⁴³⁷
-----------------------	-------	--------	----------	-------------------

V6 4.0L FI (1GRFE)	VO-25	VA-195	VCA-1037	NS ⁴³⁷
--------------------	-------	--------	----------	-------------------

Se reporter à table de matière pour les notes en bas de page en français. Utilize el contenido para ver notas a pie.

NS - Non-Serviceable / Non réparable / No reparable LF - Life-Time Filter / Filtro para toda la vida / Filtre à vie

⁴³⁷ Requires replacement of the complete fuel pump/fuel filter module. ¹¹³⁴Dust Filter. Replace with VCA-1032 when stock is depleted.



TOYOTA (cont'd)

	Oil	Air	Cabin*	Fuel
2007				
Tundra				
V6 4.0L FI (1GRFE)	VO-25	VA-195	VCA-1031	NS ⁴³⁷
V8 4.7L FI (2UZFE)	VO-25	VA-234	VCA-1031	NS ⁴³⁷
V8 5.7L FI (3URFE)	VO-96	VA-234	VCA-1031	NS ⁴³⁷
Yaris				
4 cyl 1.5L (1NZFE)	VO-40	VA-231	VCA-1031	NS ⁴³⁷
2006				
4-Runner				
V6 4.0L FI (1GRFE)	VO-25	VA-195	VCA-1014 ¹¹³⁴	NS ⁴³⁷
V8 4.7L FI (2UZFE)	VO-25	VA-146	VCA-1014 ¹¹³⁴	NS ⁴³⁷
Avalon				
V6 3.5L FI (2GRFE)	VO-84	VA-209	VCA-1031	NS ⁴³⁷
Camry				
4 cyl 2.4L FI (2AZFE)	VO-40	VA-163	VCA-1014 ¹¹³⁴	NS ⁴³⁷
V6 3.0L FI (1MZFE)	VO-25	VA-163	VCA-1014 ¹¹³⁴	NS ⁴³⁷
V6 3.3L FI (3MZFE)	VO-25	VA-163	VCA-1014 ¹¹³⁴	NS ⁴³⁷
Corolla				
4 cyl 1.8L FI (1ZZFE)	VO-40	VA-171	VCA-1028	NS ⁴³⁷
4 cyl 1.8L FI (2ZZGE)	VO-40	VA-171	VCA-1028	NS ⁴³⁷
Highlander				
4 cyl 2.4L FI (2AZFE)	VO-40	VA-163	VCA-1067	NS ⁴³⁷
V6 3.3L FI (3MZFE)	VO-25	VA-163	VCA-1067	NS ⁴³⁷
V6 3.3L FI (Hybrid)	VO-25	VA-353	VCA-1067	NS ⁴³⁷
Land Cruiser				
V8 4.7L FI (2UZFE)	VO-25	VA-146		
Matrix				
4 cyl 1.8L FI (1ZZFE)	VO-40	VA-171	VCA-1028	NS ⁴³⁷
4 cyl 1.8L FI (2ZZGE)	VO-40	VA-171	VCA-1028	NS ⁴³⁷
MR2 Spyder				
4 cyl 1.8L FI (Mexico)	VO-40	VA-414		NS ⁴³⁷
Prius				
4 cyl 1.5L FI (Hybrid)	VO-40	VA-251	VCA-1014 ¹¹³⁴	NS ⁴³⁷
RAV4				
4 cyl 2.4L FI (2AZFE)	VO-40	VA-209	VCA-1031	NS ⁴³⁷
V6 3.5L FI (2GRFE)	VO-84	VA-209	VCA-1031	NS ⁴³⁷
Sequoia				
V8 4.7L FI (2UZFE)	VO-25	VA-146		NS ⁴³⁷
Sienna				
V6 3.3L FI (3MZFE)	VO-25	VA-163	VCA-1014 ¹¹³⁴	NS ⁴³⁷
Solara				
4 cyl 2.4L FI (2AZFE)	VO-40	VA-163	VCA-1014 ¹¹³⁴	NS ⁴³⁷
V6 3.3L FI (3MZFE)	VO-25	VA-163	VCA-1014 ¹¹³⁴	NS ⁴³⁷
Tacoma				
4 cyl 2.7L FI (2TRFE)	VO-25	VA-248	VCA-1037	NS ⁴³⁷
V6 4.0L FI (1GRFE)	VO-25	VA-195	VCA-1037	NS ⁴³⁷
Tundra				
V6 4.0L FI (1GRFE)	VO-25	VA-195		NS ⁴³⁷
V8 4.7L FI (2UZFE)	VO-25	VA-146		NS ⁴³⁷
Yaris				
4 cyl 1.5L FI (1NZFE) (Canada)	VO-40	VA-231	VCA-1031	NS ⁴³⁷

Se reporter à table de matière pour les notes en bas de page en français. Utilize el contenido para ver notas a pie.

NS - Non-Serviceable / Non réparable / No reparable LF - Life-Time Filter / Filtro para toda la vida / Filtre à vie

⁴³⁷ Requires replacement of the complete fuel pump/fuel filter module. ¹¹³⁴Dust Filter. Replace with VCA-1032 when stock is depleted.



TOYOTA (cont'd)

2005

4-Runner

V6 4.0L FI (1GRFE)	VO-25	VA-195	VCA-1014 ¹¹³⁴	NS ⁴³⁷
V8 4.7L FI (2UZFE)	VO-25	VA-146	VCA-1014 ¹¹³⁴	NS ⁴³⁷

Avalon

V6 3.5L FI (2GRFE)	VO-84	VA-209	VCA-1031	NS
--------------------	-------	--------	----------	----

Camry

4 cyl. 2.4L FI (2AZFE)	VO-40	VA-163	VCA-1014 ¹¹³⁴	NS ⁴³⁷
V6 3.0L FI (1MZFE)	VO-25	VA-163	VCA-1014 ¹¹³⁴	NS ⁴³⁷
V6 3.3L FI (3MZFE)	VO-25	VA-163	VCA-1014 ¹¹³⁴	NS ⁴³⁷

Celica

4 cyl. 1.8L FI (1ZZFE)	VO-40	VA-414	VCA-1014 ¹¹³⁴	NS ⁴³⁷
4 cyl. 1.8L FI (2ZZGE)	VO-40	VA-414	VCA-1014 ¹¹³⁴	NS ⁴³⁷

Corolla

4 cyl. 1.8L FI (1ZZFE)	VO-40	VA-171	VCA-1028	NS ⁴³⁷
4 cyl. 1.8L FI (2ZZGE)	VO-40	VA-171	VCA-1028	NS ⁴³⁷

Echo

4 cyl. 1.5L FI (1NZFE)	VO-40	VA-191	VCA-1042	NS ⁴³⁷
------------------------	-------	--------	----------	-------------------

Highlander

4 cyl. 2.4L FI (2AZFE)	VO-40	VA-163	VCA-1067	NS ⁴³⁷
V6 3.3L FI (3MZFE)	VO-25	VA-163	VCA-1067	NS ⁴³⁷

Land Cruiser

V8 4.7L FI (2UZFE)	VO-25	VA-146		
--------------------	-------	--------	--	--

Matrix

4 cyl. 1.8L FI (1ZZFE)	VO-40	VA-171	VCA-1028	NS ⁴³⁷
4 cyl. 1.8L FI (2ZZGE)	VO-40	VA-171	VCA-1028	NS ⁴³⁷

MR2 Spyder

4 cyl. 1.8L FI (1ZZFE)	VO-40	VA-414		NS ⁴³⁷
------------------------	-------	--------	--	-------------------

Prius

4 cyl. 1.5L FI (Hybrid)	VO-40	VA-251	VCA-1014 ¹¹³⁴	NS ⁴³⁷
-------------------------	-------	--------	--------------------------	-------------------

RAV4

4 cyl. 2.4L FI (2AZFE)	VO-40	VA-170	VCA-1042	NS ⁴³⁷
------------------------	-------	--------	----------	-------------------

Sequoia

V8 4.7L FI (2UZFE)	VO-25	VA-146		NS ⁴³⁷
--------------------	-------	--------	--	-------------------

Sienna

V6 3.3L FI (3MZFE)	VO-25	VA-163	VCA-1014 ¹¹³⁴	NS ⁴³⁷
--------------------	-------	--------	--------------------------	-------------------

Solara

4 cyl. 2.4L FI (2AZFE)	VO-40	VA-163	VCA-1014 ¹¹³⁴	NS ⁴³⁷
V6 3.3L FI (3MZFE)	VO-25	VA-163	VCA-1014 ¹¹³⁴	NS ⁴³⁷

Tacoma

4 cyl. 2.7L FI (2TRFE)	VO-25	VA-248	VCA-1037	NS ⁴³⁷
V6 4.0L FI (1GRFE)	VO-25	VA-195	VCA-1037	NS ⁴³⁷

Tundra

V6 4.0L FI (1GRFE)	VO-25	VA-195		NS ⁴³⁷
V8 4.7L FI (2UZFE)	VO-25	VA-146		NS ⁴³⁷

2004

4-Runner

V6 4.0L FI (1GRFE)	VO-25	VA-195	VCA-1014 ¹¹³⁴	NS ⁴³⁷
V8 4.7L FI (2UZFE)	VO-25	VA-146	VCA-1014 ¹¹³⁴	NS ⁴³⁷

Avalon

V6 3.0L FI (1MZFE)	VO-25	VA-102	VCA-1014 ¹¹³⁴	
--------------------	-------	--------	--------------------------	--

Camry

4 cyl. 2.4L FI (2AZFE)	VO-40	VA-163	VCA-1014 ¹¹³⁴	NS ⁴³⁷
------------------------	-------	--------	--------------------------	-------------------

Se reporter à table de matière pour les notes en bas de page en français. Utilize el contenido para ver notas a pie.

NS - Non-Serviceable / Non réparable / No reparable LF - Life-Time Filter / Filtro para toda la vida / Filtre à vie

⁴³⁷ Requires replacement of the complete fuel pump/fuel filter module. ¹¹³⁴Dust Filter. Replace with VCA-1032 when stock is depleted.



TOYOTA (cont'd)

	Oil	Air	Cabin*	Fuel
2004				
Camry				
V6 3.0L FI (1MZFE)	VO-25	VA-163	VCA-1014 ¹¹³⁴	NS ⁴³⁷
V6 3.3L FI (3MZFE)	VO-25	VA-163	VCA-1014 ¹¹³⁴	NS ⁴³⁷
Celica				
4 cyl. 1.8L FI (1ZZFE)	VO-40	VA-414	VCA-1014 ¹¹³⁴	NS ⁴³⁷
4 cyl. 1.8L FI (2ZZGE)	VO-40	VA-414	VCA-1014 ¹¹³⁴	NS ⁴³⁷
Corolla				
4 cyl. 1.8L FI (1ZZFE)	VO-40	VA-171	VCA-1028	NS ⁴³⁷
Echo				
4 cyl. 1.5L FI (1NZFE)	VO-40	VA-191	VCA-1042	NS ⁴³⁷
Highlander				
4 cyl. 2.4L FI (2AZFE)	VO-40	VA-163	VCA-1067	NS ⁴³⁷
V6 3.3L FI (3MZFE)	VO-25	VA-163	VCA-1067	NS ⁴³⁷
Land Cruiser				
V8 4.7L FI (2UZFE)	VO-25	VA-146		
Matrix				
4 cyl. 1.8L FI (1ZZFE)	VO-40	VA-171	VCA-1028	NS ⁴³⁷
4 cyl. 1.8L FI (2ZZGE)	VO-40	VA-171	VCA-1028	NS ⁴³⁷
MR2 Spyder				
4 cyl. 1.8L FI (1ZZFE)	VO-40	VA-414		NS ⁴³⁷
Prius				
4 cyl. 1.5L FI (Hybrid)	VO-40	VA-251	VCA-1014 ¹¹³⁴	NS ⁴³⁷
RAV4				
4 cyl. 2.4L FI (2AZFE)	VO-40	VA-170	VCA-1042	NS ⁴³⁷
Sequoia				
V8 4.7L FI (2UZFE)	VO-25	VA-146		
Sienna				
V6 3.3L FI (3MZFE)	VO-25	VA-163	VCA-1014 ¹¹³⁴	NS ⁴³⁷
Solara				
4 cyl. 2.4L FI (2AZFE)	VO-40	VA-163	VCA-1014 ¹¹³⁴	NS ⁴³⁷
V6 3.3L FI (3MZFE)	VO-25	VA-163	VCA-1014 ¹¹³⁴	NS ⁴³⁷
Tacoma				
4 cyl. 2.4L FI (2RZFE)	VO-25	VA-96		
4 cyl. 2.7L FI (3RZFE)	VO-25	VA-96		
V6 3.4L FI (5VZFE)	VO-25	VA-125		
Tundra				
V6 3.4L FI (5VZFE)	VO-25	VA-146		
V8 4.7L FI (2UZFE)	VO-25	VA-146		
2003				
4-Runner				
V6 4.0L FI (1GRFE)	VO-25	VA-195	VCA-1014 ¹¹³⁴	NS ⁴³⁷
V8 4.7L FI (2UZFE)	VO-25	VA-146	VCA-1014 ¹¹³⁴	NS ⁴³⁷
Avalon				
V6 3.0L FI (1MZFE)	VO-25	VA-102	VCA-1014 ¹¹³⁴	
Camry				
4 cyl. 2.4L FI (2AZFE)	VO-40	VA-163	VCA-1014 ¹¹³⁴	NS ⁴³⁷
V6 3.0L FI (1MZFE)	VO-25	VA-163	VCA-1014 ¹¹³⁴	NS ⁴³⁷
Celica				
4 cyl. 1.8L FI (1ZZFE)	VO-40	VA-414	VCA-1014 ¹¹³⁴	NS ⁴³⁷
4 cyl. 1.8L FI (2ZZGE)	VO-40	VA-414	VCA-1014 ¹¹³⁴	NS ⁴³⁷
Corolla				
4 cyl. 1.8L FI (1ZZFE)	VO-40	VA-171	VCA-1028	NS ⁴³⁷

Se reporter à table de matière pour les notes en bas de page en français. Utilize el contenido para ver notas a pie.

NS - Non-Serviceable / Non réparable / No repairable LF - Life-Time Filter / Filtro para toda la vida / Filtre à vie

⁴³⁷ Requires replacement of the complete fuel pump/fuel filter module. ¹¹³⁴Dust Filter. Replace with VCA-1032 when stock is depleted.



TOYOTA (cont'd)

2003

Echo

4 cyl. 1.5L FI (1NZFE)	VO-40	VA-191	VCA-1042	NS ⁴³⁷
------------------------	-------	--------	----------	-------------------

Highlander

4 cyl. 2.4L FI (2AZFE)	VO-40	VA-163	VCA-1067	NS ⁴³⁷
------------------------	-------	--------	----------	-------------------

V6 3.0L FI (1MZFE)	VO-25	VA-163	VCA-1067	NS ⁴³⁷
--------------------	-------	--------	----------	-------------------

Land Cruiser

V8 4.7L FI (2UZFE)	VO-25	VA-146		
--------------------	-------	--------	--	--

Matrix

4 cyl. 1.8L FI (1ZZFE)	VO-40	VA-171	VCA-1028	NS ⁴³⁷
------------------------	-------	--------	----------	-------------------

4 cyl. 1.8L FI (2ZZGE)	VO-40	VA-171	VCA-1028	NS ⁴³⁷
------------------------	-------	--------	----------	-------------------

MR2 Spyder

4 cyl. 1.8L FI (1ZZFE)	VO-40	VA-414		NS ⁴³⁷
------------------------	-------	--------	--	-------------------

Prius

4 cyl. 1.5L FI (Hybrid)	VO-40	VA-399	VCA-1014 ¹¹³⁴	NS ⁴³⁷
-------------------------	-------	--------	--------------------------	-------------------

RAV4

4 cyl. 2.0L FI (1AZFE)	VO-40	VA-170	VCA-1042	NS ⁴³⁷
------------------------	-------	--------	----------	-------------------

Sequoia

V8 4.7L FI (2UZFE)	VO-25	VA-146		
--------------------	-------	--------	--	--

Sienna

V6 3.0L FI (1MZFE)	VO-25	VA-102		NS ⁴³⁷
--------------------	-------	--------	--	-------------------

Solara

4 cyl. 2.4L FI (2AZFE)	VO-40	VA-102		
------------------------	-------	--------	--	--

V6 3.0L FI (1MZFE)	VO-25	VA-102		
--------------------	-------	--------	--	--

Tacoma

4 cyl. 2.4L FI (2RZFE)	VO-25	VA-96		
------------------------	-------	-------	--	--

4 cyl. 2.7L FI (3RZFE)	VO-25	VA-96		
------------------------	-------	-------	--	--

V6 3.4L FI (5VZFE)	VO-25	VA-125		
--------------------	-------	--------	--	--

Tundra

V6 3.4L FI (5VZFE)	VO-25	VA-146		
--------------------	-------	--------	--	--

V8 4.7L FI (2UZFE)	VO-25	VA-146		
--------------------	-------	--------	--	--

2002

4-Runner

V6 3.4L FI (5VZFE)	VO-25	VA-125		
--------------------	-------	--------	--	--

Avalon

V6 3.0L FI (1MZFE)	VO-25	VA-102	VCA-1014 ¹¹³⁴	
--------------------	-------	--------	--------------------------	--

Camry

4 cyl. 2.4L FI (2AZFE)	VO-40	VA-163	VCA-1014 ¹¹³⁴	NS ⁴³⁷
------------------------	-------	--------	--------------------------	-------------------

V6 3.0L FI (1MZFE)	VO-25	VA-163	VCA-1014 ¹¹³⁴	NS ⁴³⁷
--------------------	-------	--------	--------------------------	-------------------

Celica

4 cyl. 1.8L FI (1ZZFE)	VO-40	VA-414	VCA-1014 ¹¹³⁴	NS ⁴³⁷
------------------------	-------	--------	--------------------------	-------------------

4 cyl. 1.8L FI (2ZZGE)	VO-40	VA-414	VCA-1014 ¹¹³⁴	NS ⁴³⁷
------------------------	-------	--------	--------------------------	-------------------

Corolla

4 cyl. 1.8L FI (1ZZFE)	VO-40	VFAP-7892	VCA-1028	NS ⁴³⁷
------------------------	-------	-----------	----------	-------------------

Echo

4 cyl. 1.5L FI (1NZFE)	VO-40	VA-191	VCA-1042	NS ⁴³⁷
------------------------	-------	--------	----------	-------------------

Highlander

4 cyl. 2.4L FI (2AZFE)	VO-40	VA-163	VCA-1067	NS ⁴³⁷
------------------------	-------	--------	----------	-------------------

V6 3.0L FI (1MZFE)	VO-25	VA-163	VCA-1067	NS ⁴³⁷
--------------------	-------	--------	----------	-------------------

Land Cruiser

V8 4.7L FI (2UZFE)	VO-25	VA-146		
--------------------	-------	--------	--	--

MR2 Spyder

4 cyl. 1.8L FI (1ZZFE)	VO-40	VA-414		NS ⁴³⁷
------------------------	-------	--------	--	-------------------

Se reporter à table de matière pour les notes en bas de page en français. Utilize el contenido para ver notas a pie.

NS - Non-Serviceable / Non réparable / No repairable LF - Life-Time Filter / Filtro para toda la vida / Filtre à vie

⁴³⁷ Requires replacement of the complete fuel pump/fuel filter module. ¹¹³⁴Dust Filter. Replace with VCA-1032 when stock is depleted.



TOYOTA (cont'd)

	Oil	Air	Cabin*	Fuel
2002				
Prius				
4 cyl. 1.5L FI (Hybrid)	VO-40	VA-399	VCA-1014 ¹¹³⁴	NS ⁴³⁷
RAV4				
4 cyl. 2.0L FI (1AZFE)	VO-40	VA-170	VCA-1042	NS ⁴³⁷
Sequoia				
V8 4.7L FI (2UZFE)	VO-25	VA-146		
Sienna				
V6 3.0L FI (1MZFE)	VO-25	VA-102		NS ⁴³⁷
Solara				
4 cyl. 2.4L FI (2AZFE)	VO-40	VA-102		
V6 3.0L FI (1MZFE)	VO-25	VA-102		
Tacoma				
4 cyl. 2.4L FI (2RZFE)	VO-25	VA-96		
4 cyl. 2.7L FI (3RZFE)	VO-25	VA-96		
V6 3.4L FI (5VZFE)	VO-25	VA-125		
Tundra				
V6 3.4L FI (5VZFE)	VO-25	VA-146		
V8 4.7L FI (2UZFE)	VO-25	VA-146		
2001				
4-Runner				
V6 3.4L FI (5VZFE)	VO-25	VA-125		
Avalon				
V6 3.0L FI (1MZFE)	VO-25	VA-102	VCA-1014 ¹¹³⁴	
Camry				
4 cyl. 2.2L FI GAS	VO-40	VA-102		
4 cyl. 2.2L FI (CNG)	VO-40	VA-102		
V6 3.0L FI (1MZFE)	VO-25	VA-102		
Celica				
4 cyl. 1.8L FI (1ZZFE)	VO-40	VA-414	VCA-1014 ¹¹³⁴	NS ⁴³⁷
4 cyl. 1.8L FI (2ZZGE)	VO-40	VA-414	VCA-1014 ¹¹³⁴	NS ⁴³⁷
Corolla				
4 cyl. 1.8L FI (1ZZFE)	VO-40	VFAP-7892		NS ⁴³⁷
Echo				
4 cyl. 1.5L FI (1NZFE)	VO-40	VA-191	VCA-1042	NS ⁴³⁷
Highlander				
4 cyl. 2.4L FI (2AZFE)	VO-40	VA-163	VCA-1067	NS ⁴³⁷
V6 3.0L FI (1MZFE)	VO-25	VA-163	VCA-1067	NS ⁴³⁷
Land Cruiser				
V8 4.7L FI (2UZFE)	VO-25	VA-146		
MR2 Spyder				
4 cyl. 1.8L FI (1ZZFE)	VO-40	VA-414		NS ⁴³⁷
Prius				
4 cyl. 1.5L FI (Hybrid)	VO-40	VA-399	VCA-1014 ¹¹³⁴	NS ⁴³⁷
RAV4				
4 cyl. 2.0L FI (1AZFE)	VO-40	VA-170	VCA-1042	NS ⁴³⁷
Sequoia				
V8 4.7L FI (2UZFE)	VO-25	VA-146		
Sienna				
V6 3.0L FI (1MZFE)	VO-25	VA-102		NS ⁴³⁷
Solara				
4 cyl. 2.2L FI (5SFE)	VO-40	VA-102		
V6 3.0L FI (1MZFE)	VO-25	VA-102		

Se reporter à table de matière pour les notes en bas de page en français. Utilize el contenido para ver notas a pie.

NS - Non-Serviceable / Non réparable / No reparable LF - Life-Time Filter / Filtro para toda la vida / Filtre à vie

⁴³⁷ Requires replacement of the complete fuel pump/fuel filter module. ¹¹³⁴Dust Filter. Replace with VCA-1032 when stock is depleted.



TOYOTA (cont'd)

2001

Tacoma

4 cyl. 2.4L FI (2RZFE)	VO-25	VA-96		
4 cyl. 2.7L FI (3RZFE)	VO-25	VA-96		
V6 3.4L FI (5VZFE)	VO-25	VA-125		

Tundra

V6 3.4L FI (5VZFE)	VO-25	VA-146		
V8 4.7L FI (2UZFE)	VO-25	VA-146		

2000

4-Runner

4 cyl. 2.7L FI (3RZFE)	VO-25	VA-96		
V6 3.4L FI (5VZFE)	VO-25	VA-125		

Avalon

V6 3.0L FI (1MZFE)	VO-25	VA-102	VCA-1014 ¹¹³⁴	
--------------------	-------	--------	--------------------------	--

Camry

4 cyl. 2.2L FI (5SFE)	VO-40	VA-102		
V6 3.0L FI (1MZFE)	VO-25	VA-102		

Celica

4 cyl. 1.8L FI (1ZZFE)	VO-40	VA-414	VCA-1014 ¹¹³⁴	NS ⁴³⁷
4 cyl. 1.8L FI (2ZZGE)	VO-40	VA-414	VCA-1014 ¹¹³⁴	NS ⁴³⁷

Corolla

4 cyl. 1.8L FI (1ZZFE)	VO-40	VFAP-7892		NS ⁴³⁷
------------------------	-------	-----------	--	-------------------

Echo

4 cyl. 1.5L FI (1NZFE)	VO-40	VA-191	VCA-1042	NS ⁴³⁷
------------------------	-------	--------	----------	-------------------

Land Cruiser

V8 4.7L FI (2UZFE)	VO-25	VA-146		
--------------------	-------	--------	--	--

MR2 Spyder

4 cyl. 1.8L FI (1ZZFE)	VO-40	VA-414		NS ⁴³⁷
------------------------	-------	--------	--	-------------------

RAV4

4 cyl. 2.0L FI (3SFE)	VO-40	VA-84		
-----------------------	-------	-------	--	--

Sienna

V6 3.0L FI (1MZFE)	VO-25	VA-102		
--------------------	-------	--------	--	--

Solara

4 cyl. 2.2L FI (5SFE)	VO-40	VA-102		
V6 3.0L FI (1MZFE)	VO-25	VA-102		

Tacoma

4 cyl. 2.4L FI (2RZFE)	VO-25	VA-96		
4 cyl. 2.7L FI (3RZFE)	VO-25	VA-96		
V6 3.4L FI (5VZFE)	VO-25	VA-125		

Tundra

V6 3.4L FI (5VZFE)	VO-25	VA-146		
V8 4.7L FI (2UZFE)	VO-25	VA-146		

1999

4-Runner

4 cyl. 2.7L FI (3RZFE)	VO-25	VA-96		
V6 3.4L FI (5VZFE)	VO-25	VA-125		

Avalon

V6 3.0L FI (1MZFE)	VO-25	VA-102		
--------------------	-------	--------	--	--

Camry

4 cyl. 2.2L FI (5SFE)	VO-40	VA-102		
V6 3.0L FI (1MZFE)	VO-25	VA-102		

Celica

4 cyl. 2.2L FI (5SFE)	VO-40	VA-102		
-----------------------	-------	--------	--	--

Se reporter à table de matière pour les notes en bas de page en français. Utilize el contenido para ver notas a pie.

NS - Non-Serviceable / Non réparable / No reparable LF - Life-Time Filter / Filtro para toda la vida / Filtre à vie

⁴³⁷ Requires replacement of the complete fuel pump/fuel filter module. ¹¹³⁴Dust Filter. Replace with VCA-1032 when stock is depleted.



TOYOTA (cont'd)

	Oil	Air	Cabin*	Fuel
1999				
Corolla				
4 cyl. 1.8L FI (1ZZFE)	VO-40	VFAP-7892		NS ⁴³⁷
Land Cruiser				
V8 4.7L FI (2UZFE)	VO-25	VA-146		
Paseo				
4 cyl. 1.5L FI (5EFE)	VO-40	VA-98		
RAV4				
4 cyl. 2.0L FI (3SFE)	VO-40	VA-84		
Sienna				
V6 3.0L FI (1MZFE)	VO-25	VA-102		
Solara				
4 cyl. 2.2L FI (5SFE)	VO-40	VA-102		
V6 3.0L FI (1MZFE)	VO-25	VA-102		
Tacoma				
4 cyl. 2.4L FI (2RZFE)	VO-25	VA-96		
4 cyl. 2.7L FI (3RZFE)	VO-25	VA-96		
V6 3.4L FI (5VZFE)	VO-25	VA-125		
Tercel				
4 cyl. 1.5L FI (5EFE)	VO-40	VA-98		
1998				
4-Runner				
4 cyl. 2.7L FI (3RZFE)	VO-25	VA-96		
V6 3.4L FI (5VZFE)	VO-25	VA-125		
Avalon				
V6 3.0L FI (1MZFE)	VO-25	VA-102		
Camry				
4 cyl. 2.2L FI (5SFE)	VO-40	VA-102		
V6 3.0L FI (1MZFE)	VO-25	VA-102		
Celica				
4 cyl. 2.2L FI (5SFE)	VO-40	VA-102		
Corolla				
4 cyl. 1.8L FI (1ZZFE)	VO-40	VFAP-7892		NS ⁴³⁷
Land Cruiser				
V8 4.7L FI (2UZFE)	VO-25	VA-146		
Paseo				
4 cyl. 1.5L FI (5EFE)	VO-40	VA-98		
RAV4				
4 cyl. 2.0L FI (3SFE)	VO-40	VA-84		
Sienna				
V6 3.0L FI (1MZFE)	VO-25	VA-102		
Supra				
6 cyl. 3.0L FI Non Turbo (2JZGE)	VO-25	VA-125		
6 cyl. 3.0L FI Turbo (2JZGTE)	VO-25	VA-125		
T100 Pickup				
4 cyl. 2.7L FI (3RZFE)	VO-25	VFAP-7859		
V6 3.4L FI (5VZFE)	VO-25	VFAP-7859		
Tacoma				
4 cyl. 2.4L FI (2RZFE)	VO-25	VA-96		
4 cyl. 2.7L FI (3RZFE)	VO-25	VA-96		
V6 3.4L FI (5VZFE)	VO-25	VA-125		
Tercel				
4 cyl. 1.5L FI (5EFE)	VO-40	VA-98		

Se reporter à table de matière pour les notes en bas de page en français. Utilize el contenido para ver notas a pie.

NS - Non-Serviceable / Non réparable / No reparable LF - Life-Time Filter / Filtro para toda la vida / Filtre à vie

⁴³⁷ Requires replacement of the complete fuel pump/fuel filter module.



TOYOTA (cont'd)

1997

4-Runner

4 cyl. 2.7L FI (3RZFE)	VO-25	VA-96		
V6 3.4L FI (5VZFE)	VO-25	VA-125		

Avalon

V6 3.0L FI (1MZFE)	VO-25	VA-102		
--------------------	-------	--------	--	--

Camry

4 cyl. 2.2L FI (5SFE)	VO-40	VA-102		
V6 3.0L FI (1MZFE)	VO-25	VA-102		

Celica

4 cyl. 1.8L FI (7AFE)	VO-40	VA-102		
4 cyl. 2.2L FI (5SFE)	VO-40	VA-102		

Corolla

4 cyl. 1.6L FI (4AFE)	VO-40	VFAP-7892		
4 cyl. 1.8L FI (7AFE)	VO-40	VFAP-7892		

Land Cruiser

6 cyl. 4.5L FI (1FZFE)	VO-25			
------------------------	-------	--	--	--

Paseo

4 cyl. 1.5L FI (5EFE)	VO-40	VA-98		
-----------------------	-------	-------	--	--

Previa

4 cyl. 2.4L FI (2TZFE) (S.C.)	VO-25	VA-96		
-------------------------------	-------	-------	--	--

RAV4

4 cyl. 2.0L FI (3SFE)	VO-40	VA-84		
-----------------------	-------	-------	--	--

Supra

6 cyl. 3.0L FI Turbo (2JZGTE)	VO-25	VA-125		
6 cyl. 3.0L FI Non Turbo (2JZGE)	VO-25	VA-125		

T100 Pickup

4 cyl. 2.7L FI (3RZFE)	VO-25	VFAP-7859		
V6 3.4L FI (5VZFE)	VO-25	VFAP-7859		

Tacoma

4 cyl. 2.4L FI (2RZFE)	VO-25	VA-96		
4 cyl. 2.7L FI (3RZFE)	VO-25	VA-96		
V6 3.4L FI (5VZFE)	VO-25	VA-125		

Tercel

4 cyl. 1.5L FI (5EFE)	VO-40	VA-98		
-----------------------	-------	-------	--	--

1996

4-Runner

4 cyl. 2.7L FI (3RZFE)	VO-25	VA-96		
V6 3.4L FI (5VZFE)	VO-25	VA-125		

Avalon

V6 3.0L FI (1MZFE)	VO-25	VA-102		
--------------------	-------	--------	--	--

Camry

4 cyl. 2.2L FI (5SFE)	VO-40	VA-102		
V6 3.0L FI (1MZFE)	VO-25	VA-102		

Celica

4 cyl. 1.8L FI (7AFE)	VO-40	VA-102		
4 cyl. 2.2L FI (5SFE)	VO-40	VA-102		

Corolla

4 cyl. 1.6L FI (4AFE)	VO-40	VFAP-7892		
4 cyl. 1.8L FI (7AFE)	VO-40	VFAP-7892		

Land Cruiser

6 cyl. 4.5L FI (1FZFE)	VO-1 ^{X502} VO-118 ^{Z502}			
------------------------	--	--	--	--

Se reporter à table de matière pour les notes en bas de page en français. Utilize el contenido para ver notas a pie.

NS - Non-Serviceable / Non réparable / No reparable LF - Life-Time Filter / Filtro para toda la vida / Filtre à vie

^{X502}Alternate ^{Z502}Primary



TOYOTA (cont'd)

	Oil	Air	Cabin*	Fuel
1996				
Paseo				
4 cyl. 1.5L FI (5EFE)	VO-40	VA-98		
Previa				
4 cyl. 2.4L FI (2TZFE) (S.C.)	VO-25	VA-96		
RAV4				
4 cyl. 2.0L FI (3SFE)	VO-40	VA-84		
Supra				
6 cyl. 3.0L FI Non Turbo (2JZGE)	VO-25	VA-125		
6 cyl. 3.0L FI Turbo (2JZGTE)	VO-25	VA-125		
T100 Pickup				
4 cyl. 2.7L FI (3RZFE)	VO-25	VFAP-7859		
V6 3.4L FI (5VZFE)	VO-25	VFAP-7859		
Tacoma				
4 cyl. 2.4L FI (2RZFE)	VO-25	VA-96		
4 cyl. 2.7L FI (3RZFE)	VO-25	VA-96		
V6 3.4L FI (5VZFE)	VO-25	VA-125		
Tercel				
4 cyl. 1.5L FI (5EFE)	VO-40	VA-98		
1995				
Avalon				
V6 3.0L FI (1MZFE)	VO-25	VA-102		
Camry				
4 cyl. 2.2L FI (5SFE)	VO-40	VA-102		
V6 3.0L FI (1MZFE)	VO-25	VA-102		
Celica				
4 cyl. 1.8L FI (7AFE)	VO-40	VA-102		
4 cyl. 2.2L FI (5SFE)	VO-40	VA-102		
Corolla				
4 cyl. 1.6L FI (4AFE)	VO-40	VFAP-7892		
4 cyl. 1.8L FI (7AFE)	VO-40	VFAP-7892		
Land Cruiser				
6 cyl. 4.5L FI (1FZFE)	VO-1 ^{X502} VO-118 ^{Z502}			
MR2				
4 cyl. 2.0L FI Turbo (3SGTE)	VO-40	VA-84		
4 cyl. 2.2L FI (5SFE)	VO-40	VA-84		
Paseo				
4 cyl. 1.5L FI (5EFE)	VO-40	VA-98		
Previa				
4 cyl. 2.4L FI (2TZFE)	VO-25	VA-96		
4 cyl. 2.4L FI (2TZFE) (S.C.)	VO-25	VA-96		
Pickup, 4-Runner				
4 cyl. 2.4L FI (22RE)	VO-25	VA-96		
V6 3.0L FI (3VZE)	VO-25	VA-408		
Supra				
6 cyl. 3.0L FI Turbo (2JZGTE)	VO-25	VA-125		
6 cyl. 3.0L FI Non Turbo (2JZGE)	VO-25	VA-125		
T100 Pickup				
4 cyl. 2.7L FI (3RZFE)	VO-25	VFAP-7859		
V6 3.4L FI (5VZFE)	VO-25	VFAP-7859		
Tacoma				
4 cyl. 2.4L FI (2RZFE)	VO-25	VA-96		

Se reporter à table de matière pour les notes en bas de page en français. Utilize el contenido para ver notas a pie.

NS - Non-Serviceable / Non réparable / No reparable LF - Life-Time Filter / Filtro para toda la vida / Filtre à vie

^{X502}Alternate ^{Z502}Primary



TOYOTA (cont'd)

1995

Tacoma

4 cyl. 2.7L FI (3RZFE)	VO-25	VA-96		
V6 3.4L FI (5VZFE)	VO-25	VA-125		

Tercel

4 cyl. 1.5L FI (5EFE)	VO-40	VA-98		
-----------------------	-------	-------	--	--

1994

Celica

4 cyl. 1.8L FI (7AFE)	VO-40	VA-102		
-----------------------	-------	--------	--	--

Supra

6 cyl. 3.0L FI Non Turbo (2JZGE)	VO-25	VA-125		
----------------------------------	-------	--------	--	--

1993

Supra

6 cyl. 3.0L FI Non Turbo (2JZGE)	VO-25	VA-125		
----------------------------------	-------	--------	--	--

VOLKSWAGEN

2019

Arteon

4 cyl. 2.0L Turbo	VO-117	VA-453	VCA-1189	NS ⁴³⁷
-------------------	--------	--------	----------	-------------------

Atlas

4 cyl. 2.0L Turbo	VO-117		VCA-1189	NS ⁴³⁷
V6 3.6L	VO-133		VCA-1189	NS ⁴³⁷

Beetle

4 cyl. 2.0L Turbo		VA-274	VCA-1135	
-------------------	--	--------	----------	--

Golf

4 cyl. 1.4L Turbo	VO-25		VCA-1189	NS ⁴³⁷
4 cyl. 1.8L Turbo	VO-117	VA-453	VCA-1189	NS ⁴³⁷

Golf Alltrack

4 cyl. 1.8 Turbo		VA-453	VCA-1189	NS ⁴³⁷
------------------	--	--------	----------	-------------------

Golf R

4 cyl. 2.0L Turbo		VA-453	VCA-1189	NS ⁴³⁷
-------------------	--	--------	----------	-------------------

Golf SportWagen

4 cyl. 1.4L Turbo	VO-25		VCA-1189	NS ⁴³⁷
-------------------	-------	--	----------	-------------------

GTI

4 cyl. 2.0L Turbo		VA-453	VCA-1189	NS ⁴³⁷
-------------------	--	--------	----------	-------------------

Jetta

4 cyl. 1.4L Turbo	VO-25		VCA-1189	
-------------------	-------	--	----------	--

Passat

4 cyl. 2.0L Turbo		VA-274	VCA-1135	NS ⁴³⁷
-------------------	--	--------	----------	-------------------

Tiguan

4 cyl 2.0L Turbo		VA-453	VCA-1189	LF ⁴⁵⁰
------------------	--	--------	----------	-------------------

2018

Atlas

4 cyl. 2.0L Turbo	VO-117		VCA-1189	NS ⁴³⁷
V6 3.6L	VO-133		VCA-1189	NS ⁴³⁷

Beetle

4 cyl. 2.0L Turbo	VO-117	VA-274	VCA-1135	
-------------------	--------	--------	----------	--

e-Golf

-- Electric			VCA-1189	
-------------	--	--	----------	--

Golf

4 cyl. 1.8L Turbo	VO-117	VA-453	VCA-1189	NS ⁴³⁷
-------------------	--------	--------	----------	-------------------

Golf Alltrack

4 cyl. 1.8 Turbo	VO-117	VA-453	VCA-1189	NS ⁴³⁷
------------------	--------	--------	----------	-------------------

Se reporter à table de matière pour les notes en bas de page en français. Utilize el contenido para ver notas a pie.

NS - Non-Serviceable / Non réparable / No reparable LF - Life-Time Filter / Filtro para toda la vida / Filtre à vie

⁴³⁷ Requires replacement of the complete fuel pump/fuel filter module. ⁴⁵⁰ Lifetime filter. Does not require replacement under normal conditions.



VOLKSWAGEN (cont'd)

	Oil	Air	Cabin*	Fuel
2018				
Golf R				
4 cyl. 2.0L Turbo	VO-117	VA-453	VCA-1189	NS ⁴³⁷
Golf SportWagen				
4 cyl. 1.8L Turbo	VO-117	VA-453	VCA-1189	NS ⁴³⁷
GTI				
4 cyl. 2.0L Turbo	VO-117	VA-453	VCA-1189	NS ⁴³⁷
Jetta, GLI				
4 cyl. 1.4L Turbo	VO-25		VCA-1135	
4 cyl. 1.8L Turbo	VO-117	VA-274	VCA-1135	
4 cyl. 2.0L Turbo	VO-117	VA-274	VCA-1135	
Passat				
4 cyl. 2.0L Turbo	VO-117	VA-274	VCA-1135	NS ⁴³⁷
V6 3.6L	VO-133	VA-365	VCA-1135	NS ⁴³⁷
Tiguan				
4 cyl. 2.0L Turbo	VO-117	VA-453	VCA-1189	LF ⁴⁵⁰
Tiguan Limited				
4 cyl. 2.0	VO-101	VA-274	VCA-1135	NS ⁴³⁷
2017				
Beetle				
4 cyl. 1.8L Turbo	VO-117	VA-274	VCA-1135	
4 cyl. 2.0L Turbo	VO-117	VA-274	VCA-1135	
CC				
4 cyl. 2.0L DI Turbo (CCTA, CBFA)	VO-101	VA-274	VCA-1135	NS ⁴³⁷
V6 3.6L DI	VO-133	VA-365	VCA-1135	LF ⁴⁵⁰
e-Golf				
-- Electric			VCA-1189	
Golf				
4 cyl. 1.8L Turbo	VO-117	VA-453	VCA-1189	NS ⁴³⁷
Golf Alltrack				
4 cyl. 1.8 Turbo	VO-117	VA-453	VCA-1189	NS ⁴³⁷
Golf R				
4 cyl. 2.0L Turbo	VO-117	VA-453	VCA-1189	NS ⁴³⁷
Golf SportWagen				
4 cyl. 1.8L Turbo	VO-117	VA-453	VCA-1189	NS ⁴³⁷
GTI				
4 cyl. 2.0L Turbo	VO-117	VA-453	VCA-1189	NS ⁴³⁷
Jetta, GLI				
4 cyl. 1.4L Turbo	VO-25		VCA-1135	
4 cyl. 1.8L Turbo	VO-117	VA-274	VCA-1135	
4 cyl. 2.0L Turbo	VO-117	VA-274	VCA-1135	
Passat				
4 cyl. 1.8L Turbo	VO-117	VA-274	VCA-1135	NS ⁴³⁷
V6 3.6L	VO-133	VA-365	VCA-1135	NS ⁴³⁷
Tiguan				
4 cyl. 2.0L Turbo	VO-101	VA-274	VCA-1135	NS ⁴³⁷
Touareg				
V6 3.6L	VO-133	VA-204		NS ⁴³⁷
2016				
Beetle				
4 cyl. 1.8L Turbo	VO-117	VA-274	VCA-1135	
4 cyl. 2.0L Turbo	VO-117	VA-274	VCA-1135	

Se reporter à table de matière pour les notes en bas de page en français. Utilize el contenido para ver notas a pie.

NS - Non-Serviceable / Non réparable / No repairable LF - Life-Time Filter / Filtro para toda la vida / Filtre à vie

⁴³⁷ Requires replacement of the complete fuel pump/fuel filter module. ⁴⁵⁰ Lifetime filter. Does not require replacement under normal conditions.



VOLKSWAGEN (cont'd)

2016

CC

4 cyl 2.0L DI Turbo (CCTA, CBFA)	VO-101	VA-274	VCA-1135	NS ⁴³⁷
V6 3.6L DI	VO-133	VA-365	VCA-1135	LF ⁴⁵⁰

e-Golf

-- Electric			VCA-1189	
-------------	--	--	----------	--

EOS

4 cyl 2.0L DI Turbo (CCTA, CBFA)	VO-101	VA-274	VCA-1135	
----------------------------------	--------	--------	----------	--

Golf

4 cyl. 1.8L Turbo	VO-117	VA-453	VCA-1189	NS ⁴³⁷
-------------------	--------	--------	----------	-------------------

Golf R

4 cyl. 2.0L Turbo	VO-117	VA-453	VCA-1189	NS ⁴³⁷
-------------------	--------	--------	----------	-------------------

Golf SportWagen

4 cyl. 1.8L Turbo	VO-117	VA-453	VCA-1189	NS ⁴³⁷
-------------------	--------	--------	----------	-------------------

GTI

4 cyl. 2.0L Turbo	VO-117	VA-453	VCA-1189	NS ⁴³⁷
-------------------	--------	--------	----------	-------------------

Jetta, GLI

4 cyl. 1.4L Turbo	VO-25		VCA-1135	
4 cyl. 1.4L Turbo (Hybrid)	VO-25		VCA-1135	
4 cyl. 1.8L Turbo	VO-117	VA-274	VCA-1135	
4 cyl. 2.0L Turbo	VO-117	VA-274	VCA-1135	

Passat

4 cyl. 1.8L Turbo	VO-117	VA-274	VCA-1135	NS ⁴³⁷
V6 3.6L	VO-133	VA-365	VCA-1135	NS ⁴³⁷

Tiguan

4 cyl. 2.0L Turbo	VO-101	VA-274	VCA-1135	NS ⁴³⁷
-------------------	--------	--------	----------	-------------------

Touareg

V6 3.6L	VO-133	VA-204		NS ⁴³⁷
---------	--------	--------	--	-------------------

2015

Beetle

4 cyl. 1.8L Turbo	VO-117	VA-274	VCA-1135	
4 cyl. 2.0L Diesel Turbo	VO-165	VA-274	VCA-1135	
4 cyl. 2.0L Turbo	VO-117	VA-274	VCA-1135	

CC

4 cyl 2.0L DI Turbo (CCTA, CBFA)	VO-101	VA-274	VCA-1135	NS ⁴³⁷
V6 3.6L DI	VO-133	VA-365	VCA-1135	LF ⁴⁵⁰

e-Golf

-- Electric			VCA-1189	
-------------	--	--	----------	--

EOS

4 cyl 2.0L DI Turbo (CCTA, CBFA)	VO-101	VA-274	VCA-1135	
----------------------------------	--------	--------	----------	--

Golf

4 cyl. 1.8L Turbo	VO-117	VA-453	VCA-1189	NS ⁴³⁷
4 cyl. 2.0L Diesel Turbo	VO-165	VA-453	VCA-1189	

Golf R

4 cyl. 2.0L Turbo	VO-117	VA-453	VCA-1189	NS ⁴³⁷
-------------------	--------	--------	----------	-------------------

Golf SportWagen

4 cyl. 1.8L Turbo	VO-117	VA-453	VCA-1189	NS ⁴³⁷
4 cyl. 2.0L Diesel Turbo	VO-165	VA-453	VCA-1189	

GTI

4 cyl. 2.0L Turbo	VO-117	VA-453	VCA-1189	NS ⁴³⁷
-------------------	--------	--------	----------	-------------------

Jetta, GLI

4 cyl. 1.4L Turbo (Hybrid)	VO-25		VCA-1135	
4 cyl. 1.8L Turbo	VO-117	VA-274	VCA-1135	

Se reporter à table de matière pour les notes en bas de page en français. Utilize el contenido para ver notas a pie.

NS - Non-Serviceable / Non réparable / No reparable LF - Life-Time Filter / Filtro para toda la vida / Filtre à vie

⁴³⁷ Requires replacement of the complete fuel pump/fuel filter module. ⁴⁵⁰ Lifetime filter. Does not require replacement under normal conditions.



VOLKSWAGEN (cont'd)

	Oil	Air	Cabin*	Fuel
2015				
Jetta, GLI				
4 cyl. 2.0L Diesel Turbo	VO-165	VA-274	VCA-1135	
4 cyl. 2.0L Non turbo	VO-15		VCA-1135	
4 cyl. 2.0L Turbo	VO-117	VA-274	VCA-1135	
Passat				
4 cyl. 1.8L Turbo	VO-117	VA-274	VCA-1135	NS ⁴³⁷
4 cyl. 2.0L Diesel Turbo	VO-165	VA-274	VCA-1135	
V6 3.6L	VO-133	VA-365	VCA-1135	NS ⁴³⁷
Tiguan				
4 cyl. 2.0L Turbo	VO-101	VA-274	VCA-1135	NS ⁴³⁷
Touareg				
V6 3.0L FI (S.C.) Hybrid	VO-92			NS ⁴³⁷
V6 3.6L DI	VO-133	VA-204		NS ⁴³⁷
2014				
Beetle				
4 cyl. 1.8L Turbo	VO-117	VA-274	VCA-1135	
4 cyl. 2.0L Diesel Turbo	VO-77	VA-274	VCA-1135	
4 cyl. 2.0L Turbo	VO-117	VA-274	VCA-1135	
5 cyl. 2.5L	VO-85	VA-226	VCA-1135	
CC				
4 cyl. 2.0L DI Turbo (CCTA, CBFA)	VO-101	VA-274	VCA-1135	NS ⁴³⁷
V6 3.6L DI	VO-133	VA-365	VCA-1135	LF ⁴⁵⁰
EOS				
4 cyl. 2.0L DI Turbo (CCTA, CBFA)	VO-101	VA-274	VCA-1135	
Golf				
4 cyl. 2.0L Diesel Turbo	VO-77	VA-274	VCA-1135	
5 cyl. 2.5L	VO-85	VA-226	VCA-1135	
GTI				
4 cyl. 2.0L Turbo	VO-101	VA-274	VCA-1135	
Jetta, GLI				
4 cyl. 1.4L Turbo (Hybrid)	VO-25		VCA-1135	
4 cyl. 1.8L Turbo	VO-117	VA-274	VCA-1135	
4 cyl. 2.0L Diesel Turbo	VO-77	VA-274	VCA-1135	
4 cyl. 2.0L FI Non Turbo (CBPA)	VO-15		VCA-1135	
4 cyl. 2.0L Turbo	VO-117	VA-274	VCA-1135	
5 cyl. 2.5L	VO-85	VA-226	VCA-1135	
Passat				
4 cyl. 1.8L Turbo	VO-117	VA-274	VCA-1135	NS ⁴³⁷
4 cyl. 2.0L Diesel Turbo	VO-132	VA-274	VCA-1135	
5 cyl. 2.5L	VO-85	VA-226	VCA-1135	NS ⁴³⁷
V6 3.6L	VO-133	VA-365	VCA-1135	NS ⁴³⁷
Routan				
V6 3.6L	VO-114	VA-286	VCA-1044	NS ⁴³⁷
Tiguan				
4 cyl. 2.0L Turbo	VO-101	VA-274	VCA-1135	NS ⁴³⁷
Touareg				
V6 3.0L FI (S.C.) Hybrid	VO-92			NS ⁴³⁷
V6 3.6L	VO-133	VA-204		NS ⁴³⁷
2013				
Beetle				
4 cyl. 2.0L DI Turbo (CCTA, CBFA)	VO-101	VA-274	VCA-1135	
4 cyl. 2.0L DI Turbo (CPLA, CPPA)	VO-117	VA-274	VCA-1135	
4 cyl. 2.0L Diesel Turbo	VO-77	VA-274	VCA-1135	

Se reporter à table de matière pour les notes en bas de page en français. Utilize el contenido para ver notas a pie.

NS - Non-Serviceable / Non réparable / No reparable LF - Life-Time Filter / Filtro para toda la vida / Filtre à vie

⁴³⁷ Requires replacement of the complete fuel pump/fuel filter module. ⁴⁵⁰ Lifetime filter. Does not require replacement under normal conditions.



VOLKSWAGEN (cont'd)

2013

Beetle

5 cyl 2.5L	VO-85	VA-226	VCA-1135	
------------	-------	--------	----------	--

CC

4 cyl 2.0L DI Turbo (CCTA, CBFA)	VO-101	VA-274	VCA-1135	LF ⁴⁵⁰
----------------------------------	--------	--------	----------	-------------------

V6 3.6L DI	VO-133	VA-365	VCA-1135	LF ⁴⁵⁰
------------	--------	--------	----------	-------------------

EOS

4 cyl 2.0L DI Turbo (CCTA, CBFA)	VO-101	VA-274	VCA-1135	
----------------------------------	--------	--------	----------	--

Golf

4 cyl. 2.0L Diesel Turbo	VO-77	VA-274	VCA-1135	
--------------------------	-------	--------	----------	--

4 cyl. 2.0L Turbo	VO-101	VA-274	VCA-1135	
-------------------	--------	--------	----------	--

5 cyl. 2.5L	VO-85	VA-226	VCA-1135	
-------------	-------	--------	----------	--

Golf R

4 cyl. 2.0L FI Turbo (CRZA)	VO-85	VA-318	VCA-1135	
-----------------------------	-------	--------	----------	--

GTI

4 cyl. 2.0L Turbo	VO-101	VA-274	VCA-1135	
-------------------	--------	--------	----------	--

Jetta, GLI

4 cyl. 1.4L Turbo (Hybrid)	VO-25		VCA-1135	
----------------------------	-------	--	----------	--

4 cyl. 2.0L DI Turbo (CCTA, CBFA)	VO-101	VA-274	VCA-1135	
-----------------------------------	--------	--------	----------	--

4 cyl. 2.0L DI Turbo (CPLA, CPPA)	VO-117	VA-274	VCA-1135	
-----------------------------------	--------	--------	----------	--

4 cyl. 2.0L Diesel Turbo	VO-77	VA-274	VCA-1135	
--------------------------	-------	--------	----------	--

4 cyl. 2.0L FI Non Turbo (CBPA)	VO-15		VCA-1135	
---------------------------------	-------	--	----------	--

5 cyl. 2.5L	VO-85	VA-226	VCA-1135	
-------------	-------	--------	----------	--

Passat

4 cyl. 2.0L Diesel Turbo	VO-132	VA-274	VCA-1135	
--------------------------	--------	--------	----------	--

5 cyl. 2.5L	VO-85	VA-226	VCA-1135	NS ⁴³⁷
-------------	-------	--------	----------	-------------------

V6 3.6L	VO-133	VA-365	VCA-1135	NS ⁴³⁷
---------	--------	--------	----------	-------------------

Routan

V6 3.6L	VO-110	VA-286	VCA-1044	NS ⁴³⁷
---------	--------	--------	----------	-------------------

Tiguan

4 cyl. 2.0L Turbo	VO-101	VA-274	VCA-1135	NS ⁴³⁷
-------------------	--------	--------	----------	-------------------

Touareg

V6 3.0L FI (S.C.) Hybrid	VO-92			NS ⁴³⁷
--------------------------	-------	--	--	-------------------

V6 3.6L	VO-133	VA-204		NS ⁴³⁷
---------	--------	--------	--	-------------------

2012

Beetle

4 cyl. 2.0L DI Turbo (CCTA, CBFA)	VO-101	VA-274	VCA-1135	
-----------------------------------	--------	--------	----------	--

5 cyl 2.5L	VO-85	VA-226	VCA-1135	
------------	-------	--------	----------	--

CC

4 cyl 2.0L DI Turbo (CCTA, CBFA)	VO-101	VA-274	VCA-1135	LF ⁴⁵⁰
----------------------------------	--------	--------	----------	-------------------

V6 3.6L DI (CNNA)	VO-133	VA-365	VCA-1135	LF ⁴⁵⁰
-------------------	--------	--------	----------	-------------------

EOS

4 cyl 2.0L DI Turbo (CCTA, CBFA)	VO-101	VA-274	VCA-1135	
----------------------------------	--------	--------	----------	--

Golf

4 cyl. 2.0L Turbo Diesel (Canada & Mexico)	VO-77	VA-274	VCA-1135	
--	-------	--------	----------	--

5 cyl. 2.5L FI (CBTA, CBUA)	VO-85	VA-226	VCA-1135	
-----------------------------	-------	--------	----------	--

Golf R

4 cyl. 2.0L FI Turbo (CRZA)	VO-85	VA-318	VCA-1135	
-----------------------------	-------	--------	----------	--

GTI

4 cyl. 2.0L DI Turbo (CCTA, CBFA)	VO-101	VA-274	VCA-1135	
-----------------------------------	--------	--------	----------	--

Jetta, GLI

4 cyl. 2.0L DI Turbo (CCTA, CBFA)	VO-101	VA-274	VCA-1135	
-----------------------------------	--------	--------	----------	--

4 cyl. 2.0L Diesel Turbo	VO-77	VA-274	VCA-1135	
--------------------------	-------	--------	----------	--

Se reporter à table de matière pour les notes en bas de page en français. Utilize el contenido para ver notas a pie.

NS - Non-Serviceable / Non réparable / No reparable LF - Life-Time Filter / Filtro para toda la vida / Filtre à vie

⁴³⁷ Requires replacement of the complete fuel pump/fuel filter module. ⁴⁵⁰ Lifetime filter. Does not require replacement under normal conditions.



VOLKSWAGEN (cont'd)

2012				
Jetta, GLI				
4 cyl. 2.0L FI Non Turbo (CBPA)	VO-15		VCA-1135	
5 cyl. 2.5L	VO-85	VA-226	VCA-1135	
Passat				
4 cyl. 2.0L Diesel Turbo	VO-132	VA-274	VCA-1135	
5 cyl. 2.5L	VO-85	VA-226	VCA-1135	NS ⁴³⁷
V6 3.6L	VO-133	VA-365	VCA-1135	NS ⁴³⁷
Routan				
V6 3.6L	VO-110	VA-286	VCA-1044	NS ⁴³⁷
Tiguan				
4 cyl. 2.0L Turbo	VO-101	VA-274	VCA-1135	NS ⁴³⁷
Touareg				
V6 3.0L FI (S.C.) Hybrid	VO-92			NS ⁴³⁷
V6 3.6L	VO-133	VA-204		NS ⁴³⁷
2011				
CC				
4 cyl 2.0L DI Turbo (CCTA, CBFA)	VO-101	VA-274	VCA-1135	LF ⁴⁵⁰
V6 3.6L DI (BLV)	VO-77	VA-365	VCA-1135	LF ⁴⁵⁰
EOS				
4 cyl 2.0L DI Turbo (CCTA, CBFA)	VO-101	VA-274	VCA-1135	
Golf				
4 cyl. 2.0L Diesel Turbo	VO-77	VA-274	VCA-1135	
5 cyl. 2.5L FI (CBTA, CBUA))	VO-85	VA-226	VCA-1135	
GTI				
4 cyl. 2.0L DI Turbo (CCTA, CBFA)	VO-101	VA-274	VCA-1135	
Jetta				
4 cyl. 2.0L DI Turbo Diesel	VO-77	VA-274	VCA-1135	
4 cyl. 2.0L FI (CBPA)	VO-15		VCA-1135	
5 cyl. 2.5L FI	VO-85	VA-226	VCA-1135	
Routan				
V6 3.6L	VO-110	VA-286	VCA-1044	NS ⁴³⁷
Tiguan				
4 cyl. 2.0L Turbo	VO-101	VA-274	VCA-1135	NS ⁴³⁷
Touareg				
V6 3.0L DI Turbo Diesel		VA-204		NS ⁴³⁷
V6 3.0L FI (S.C.) Hybrid	VO-92			NS ⁴³⁷
V6 3.6L DI	VO-150	VA-204		NS ⁴³⁷
2010				
Beetle				
5 cyl 2.5L FI (BPR, BPS)	VO-85	VA-138	VCA-1026	
CC				
4 cyl 2.0L DI Turbo (CCTA, CBFA)	VO-101	VA-274	VCA-1135	LF ⁴⁵⁰
V6 3.6L DI (BLV)	VO-77	VA-365	VCA-1135	LF ⁴⁵⁰
EOS				
4 cyl 2.0L DI Turbo (CCTA, CBFA)	VO-101	VA-274	VCA-1135	
Golf				
4 cyl. 2.0L Diesel Turbo	VO-77	VA-274	VCA-1135	
5 cyl. 2.5L FI (CBTA, CBUA))	VO-85	VA-226	VCA-1135	
Golf City (Canada)				
4 cyl 2.0L FI (BEV)	VO-15	VA-138	VCA-1135	
GTI				
4 cyl. 2.0L DI Turbo (CCTA, CBFA)	VO-101	VA-274	VCA-1135	

Se reporter à table de matière pour les notes en bas de page en français. Utilize el contenido para ver notas a pie.

NS - Non-Serviceable / Non réparable / No repairable LF - Life-Time Filter / Filtro para toda la vida / Filtre à vie

⁴³⁷ Requires replacement of the complete fuel pump/fuel filter module. ⁴⁵⁰ Lifetime filter. Does not require replacement under normal conditions.



VOLKSWAGEN (cont'd)

2010

Jetta

4 cyl. 2.0L DI Turbo (CCTA, CBFA)	VO-101	VA-365	VCA-1135	
4 cyl. 2.0L DI Turbo Diesel (CBEA, CJAA)	VO-77	VA-274	VCA-1135	
5 cyl. 2.5L FI (CBTA, CBUA)	VO-85	VA-226	VCA-1135	

Passat

4 cyl 2.0L Turbo	VO-101	VA-274	VCA-1135	NS ⁴³⁷
V6 3.6L	VO-77	VA-365	VCA-1135	

Routan

V6 3.8L	VO-25	VA-154	VCA-1044	NS ⁴³⁷
V6 4.0L	VO-88	VA-154	VCA-1044	NS ⁴³⁷

Tiguan

4 cyl. 2.0L Turbo	VO-101	VA-274	VCA-1135	NS ⁴³⁷
-------------------	--------	--------	----------	-------------------

Touareg

V6 3.6L DI (BHK)	VO-150	VA-204		NS ⁴³⁷
------------------	--------	--------	--	-------------------

2009

Beetle

5 cyl 2.5L FI (BPR, BPS)	VO-85	VA-138	VCA-1026	
--------------------------	-------	--------	----------	--

CC

4 cyl 2.0L DI Turbo (CCTA)	VO-101	VA-274	VCA-1135	LF ⁴⁵⁰
V6 3.6L DI (BLV)	VO-77	VA-365	VCA-1135	LF ⁴⁵⁰

EOS

4 cyl 2.0L DI Turbo (BPY)	VO-85	VA-318	VCA-1135	
4 cyl 2.0L DI Turbo (CCTA, CBFA)	VO-101	VA-274	VCA-1135	

Golf City (Canada)

4 cyl 2.0L FI (BEV)	VO-15	VA-138	VCA-1135	
---------------------	-------	--------	----------	--

GTI

4 cyl. 2.0L DI Turbo (CCTA, CBFA)	VO-101	VA-274	VCA-1135	
-----------------------------------	--------	--------	----------	--

Jetta, GLI

4 cyl. 2.0L DI Turbo (CCTA, CBFA)	VO-101	VA-365	VCA-1135	
4 cyl. 2.0L DI Turbo Diesel (CBEA)	VO-77	VA-274	VCA-1135	
5 cyl. 2.5L FI (CBTA, CBUA)	VO-85	VA-226	VCA-1135	

Jetta City (Canada)

4 cyl 2.0L FI SOHC	VO-15	VA-138	VCA-1135	
--------------------	-------	--------	----------	--

Passat

4 cyl 2.0L DI Turbo (CCTA)	VO-101	VA-274	VCA-1135	NS ⁴³⁷
V6 3.6L DI (BLV) Canada	VO-77	VA-365	VCA-1135	

Rabbit

5 cyl 2.5L FI (CBTA, CBUA)	VO-85	VA-226	VCA-1135	
----------------------------	-------	--------	----------	--

Routan

V6 3.8L	VO-25	VA-154	VCA-1044	NS ⁴³⁷
V6 4.0L	VO-88	VA-154	VCA-1044	NS ⁴³⁷

Tiguan

4 cyl. 2.0L Turbo	VO-101	VA-274	VCA-1135	NS ⁴³⁷
-------------------	--------	--------	----------	-------------------

Touareg

V6 3.6L DI (BHK)	VO-150	VA-204		NS ⁴³⁷
V8 4.2L DI (BAR)	VO-138	VA-204 ¹¹²		NS ⁴³⁷

2008

Beetle

5 cyl 2.5L FI (BPR, BPS)	VO-85	VA-138	VCA-1026	
--------------------------	-------	--------	----------	--

EOS

4 cyl 2.0L DI Turbo (BPY)	VO-85	VA-318	VCA-1135	
V6 3.2L DI (BUB, CBRA)	VO-77	VA-365	VCA-1135	

Se reporter à table de matière pour les notes en bas de page en français. Utilize el contenido para ver notas a pie.

NS - Non-Serviceable / Non réparable / No reparable LF - Life-Time Filter / Filtro para toda la vida / Filtre à vie

¹¹² Requires two (2). ⁴³⁷ Requires replacement of the complete fuel pump/fuel filter module. ⁴⁵⁰ Lifetime filter. Does not require replacement under normal conditions.



VOLKSWAGEN (cont'd)

	Oil	Air	Cabin*	Fuel
2008				
Golf City (Canada)				
4 cyl 2.0L FI (BEV)	VO-15	VA-138	VCA-1135	
GTI				
4 cyl 2.0L DI Turbo (BPY)	VO-85	VA-318	VCA-1135	
4 cyl 2.0L DI Turbo (CCTA, CBFA)	VO-101	VA-274	VCA-1135	
Jetta, GLI				
4 cyl 2.0L DI Turbo (BPY)	VO-85	VA-318	VCA-1135	
4 cyl 2.0L DI Turbo (CCTA, CBFA)	VO-101	VA-365	VCA-1135	
5 cyl 2.5L FI	VO-85	VA-226	VCA-1135	
Jetta City (Canada)				
4 cyl 2.0L FI SOHC	VO-15	VA-138	VCA-1135	
Passat				
4 cyl 2.0L DI Turbo (BPY)	VO-85	VA-318	VCA-1135	NS ⁴³⁷
4 cyl 2.0L DI Turbo (CCTA)	VO-101	VA-318	VCA-1135	NS ⁴³⁷
V6 3.6L DI (BLV)	VO-77	VA-365	VCA-1135	
R32				
V6 3.2L FI	VO-77	VA-365	VCA-1135	LF ⁴⁵⁰
Rabbit				
5 cyl 2.5L FI (CBTA, CBUA))	VO-85	VA-226	VCA-1135	
Touareg				
V6 3.6L DI (BHK)	VO-150	VA-204		NS ⁴³⁷
V8 4.2L DI (BAR)	VO-138	VA-204 ¹¹²		NS ⁴³⁷
V10 5.0L Diesel Turbo FI	VO-139			
2007				
Beetle				
4 cyl 1.9L Diesel Turbo (BEW)	VO-71	VA-138	VCA-1026	
5 cyl 2.5L FI	VO-85	VA-138	VCA-1026	
EOS				
4 cyl 2.0L DI Turbo (BPY)	VO-85	VA-318	VCA-1135	
V6 3.2L DI (BUB)	VO-77	VA-365	VCA-1135	
Golf City (Canada)				
4 cyl 2.0L FI (BEV)	VO-15	VA-138	VCA-1135	
GTI				
4 cyl 2.0L DI Turbo (BPY)	VO-85	VA-318	VCA-1135	
Jetta, GLI				
4 cyl 2.0L DI Turbo (BPY)	VO-85	VA-318	VCA-1135	
5 cyl 2.5L FI (BGP,BGQ)	VO-85	VA-226	VCA-1135	
Jetta City (Canada)				
4 cyl 2.0L FI SOHC	VO-15	VA-138	VCA-1135	
Passat				
4 cyl 2.0L DI Turbo (BPY)	VO-85	VA-318	VCA-1135	NS ⁴³⁷
V6 3.6L DI (BLV)	VO-77	VA-365	VCA-1135	
Rabbit				
5 cyl 2.5L FI (BGP,BGQ)	VO-85	VA-226	VCA-1135	
Touareg				
V6 3.6L DI (BHK)	VO-150	VA-204		NS ⁴³⁷
V8 4.2L DI (BAR)	VO-138	VA-204 ¹¹²		NS ⁴³⁷
V8 4.2L FI (AXQ)	VO-150	VA-204 ¹¹²		NS ⁴³⁷
V10 5.0L Diesel Turbo FI	VO-139			
2006				
Beetle				
4 cyl 1.9L Diesel Turbo (BEW)	VO-71	VA-138	VCA-1026	

Se reporter à table de matière pour les notes en bas de page en français. Utilize el contenido para ver notas a pie.

NS - Non-Serviceable / Non réparable / No repairable LF - Life-Time Filter / Filtro para toda la vida / Filtre à vie

¹¹² Requires two (2). ⁴³⁷ Requires replacement of the complete fuel pump/fuel filter module. ⁴⁵⁰ Lifetime filter. Does not require replacement under normal conditions.



VOLKSWAGEN (cont'd)

2006

Beetle

5 cyl. 2.5L FI	VO-85	VA-138	VCA-1026	
----------------	-------	--------	----------	--

Golf, GTI

4 cyl. 1.8L FI Turbo (AWP)	VO-15	VA-138	VCA-1026	
4 cyl. 1.9L Diesel Turbo FI (BEW)	VO-71	VA-138	VCA-1026	
4 cyl. 2.0L DI Turbo (BPY)	VO-85	VA-318	VCA-1026	
4 cyl. 2.0L FI Non Turbo	VO-15	VA-138	VCA-1026	

Jetta, GLI

4 cyl. 1.9L Diesel Turbo DI (BRm)	VO-77	VA-274	VCA-1135	
4 cyl. 2.0L DI Turbo (BPY)	VO-85	VA-318	VCA-1135	
5 cyl. 2.5L FI (BGP,BGQ)	VO-85	VA-226	VCA-1135	

Passat

4 cyl. 2.0L DI Turbo (BPY)	VO-85	VA-318	VCA-1135	NS ⁴³⁷
V6 3.6L DI (BLV)	VO-77	VA-365	VCA-1135	NS ⁴³⁷

Phaeton

V8 4.2L FI	VO-94			
------------	-------	--	--	--

Rabbit

5 cyl. 2.5L FI (BGP,BGQ)	VO-85	VA-226	VCA-1135	
--------------------------	-------	--------	----------	--

Touareg

V6 3.2L FI (BMX)	VO-150	VA-204		NS ⁴³⁷
V8 4.2L FI (AXQ)	VO-150	VA-204 ¹¹²		NS ⁴³⁷
V10 5.0L Diesel Turbo FI	VO-139			

2005

Beetle

4 cyl. 1.8L FI Turbo	VO-15	VA-138	VCA-1026	
4 cyl. 1.9L Diesel Turbo (BEW)	VO-71	VA-138	VCA-1026	
4 cyl. 2.0L FI	VO-15	VA-138	VCA-1026	

Golf, GTI

4 cyl. 1.8L FI Turbo	VO-15	VA-138	VCA-1026	
4 cyl. 1.9L Diesel Turbo FI (BEW)	VO-71	VA-138	VCA-1026	
4 cyl. 2.0L FI	VO-15	VA-138	VCA-1026	
V6 2.8L FI (BDF)	VO-77	VA-138	VCA-1026	

Jetta, GLI

4 cyl. 1.8L FI Turbo	VO-15	VA-138	VCA-1026	
4 cyl. 1.9L Diesel Turbo DI (BRm)	VO-77	VA-274	VCA-1135	
4 cyl. 1.9L Diesel Turbo FI (BEW)	VO-71	VA-138	VCA-1026	
4 cyl. 2.0L FI	VO-15	VA-138	VCA-1026	
5 cyl. 2.5L FI (BGP,BGQ)	VO-85	VA-226	VCA-1135	

Passat

4 cyl. 1.8L FI Turbo	VO-15	VA-157	VCA-1026	
4 cyl. 2.0L Diesel Turbo	VO-71	VA-157	VCA-1026	
V6 2.8L FI (ATQ)	VO-93	VA-157	VCA-1026	

Phaeton

V8 4.2L FI	VO-94			
------------	-------	--	--	--

Touareg

V6 3.2L FI (BAA/BMX)	VO-150	VA-204		NS ⁴³⁷
V8 4.2L FI (AXQ)	VO-150	VA-204 ¹¹²		NS ⁴³⁷
V10 5.0L Diesel Turbo FI	VO-139			

2004

Beetle

4 cyl. 1.8L FI Turbo	VO-15	VA-138	VCA-1026	
4 cyl. 1.9L Diesel Turbo	VO-71	VA-138	VCA-1026	
4 cyl. 2.0L FI	VO-15	VA-138	VCA-1026	

Se reporter à table de matière pour les notes en bas de page en français. Utilize el contenido para ver notas a pie.

NS - Non-Serviceable / Non réparable / No reparable LF - Life-Time Filter / Filtro para toda la vida / Filtre à vie

¹¹² Requires two (2). ⁴³⁷ Requires replacement of the complete fuel pump/fuel filter module.



VOLKSWAGEN (cont'd)

	Oil	Air	Cabin*	Fuel
2004				
Golf, GTI				
4 cyl. 1.8L FI Turbo	VO-15	VA-138	VCA-1026	
4 cyl. 1.9L Diesel Turbo FI	VO-71	VA-138	VCA-1026	
4 cyl. 2.0L FI (BEV)	VO-15	VA-138	VCA-1026	
V6 2.8L FI (BDF)	VO-77	VA-138	VCA-1026	
V6 3.2L FI	VO-77	VA-138	VCA-1026	
Jetta, GLI				
4 cyl. 1.8L FI Turbo (AWP)	VO-15	VA-138	VCA-1026	
4 cyl. 1.9L Diesel Turbo	VO-71	VA-138	VCA-1026	
4 cyl. 2.0L FI	VO-15	VA-138	VCA-1026	
V6 2.8L FI (BDF)	VO-77	VA-138	VCA-1026	
Passat				
4 cyl. 1.8L FI Turbo	VO-15	VA-157	VCA-1026	
4 cyl. 2.0L Diesel Turbo	VO-71	VA-157	VCA-1026	
V6 2.8L FI (ATQ)	VO-93	VA-157	VCA-1026	
W8 4.0L FI	VO-150	VA-157	VCA-1026	
Phaeton				
V8 4.2L FI	VO-94			
Touareg				
V6 3.2L FI (BAA)	VO-150	VA-204		NS ⁴³⁷
V8 4.2L FI (AXQ)	VO-150	VA-204 ¹¹²		NS ⁴³⁷
V10 5.0L Diesel Turbo FI	VO-139			
2003				
Beetle				
4 cyl. 1.8L FI Turbo	VO-15	VA-138	VCA-1026	
4 cyl. 1.9L Diesel Turbo	VO-71	VA-138	VCA-1026	
4 cyl. 2.0L FI	VO-15	VA-138	VCA-1026	
Eurovan				
V6 2.8L FI (AXK)	VO-77			
Golf, GTI				
4 cyl. 1.8L FI Turbo	VO-15	VA-138	VCA-1026	
4 cyl. 1.9L Diesel Turbo FI	VO-71	VA-138	VCA-1026	
4 cyl. 2.0L FI	VO-15	VA-138	VCA-1026	
V6 2.8L FI (BDF)	VO-77	VA-138	VCA-1026	
Jetta, GLI				
4 cyl. 1.8L FI Turbo	VO-15	VA-138	VCA-1026	
4 cyl. 1.9L Diesel Turbo	VO-71	VA-138	VCA-1026	
4 cyl. 2.0L FI	VO-15	VA-138	VCA-1026	
V6 2.8L FI (BDF)	VO-77	VA-138	VCA-1026	
Passat				
4 cyl. 1.8L FI Turbo	VO-15	VA-157	VCA-1026	
V6 2.8L FI	VO-93	VA-157	VCA-1026	
W8 4.0L FI	VO-150	VA-157	VCA-1026	
2002				
Beetle				
4 cyl. 1.8L FI Turbo	VO-15	VA-138	VCA-1026	
4 cyl. 1.9L Diesel Turbo	VO-71	VA-138	VCA-1026	
4 cyl. 2.0L FI	VO-15	VA-138	VCA-1026	
Cabrio				
4 cyl. 2.0L FI	VO-15	VA-124	VCA-1026	
Eurovan				
V6 2.8L FI (AXK)	VO-77			

Se reporter à table de matière pour les notes en bas de page en français. Utilize el contenido para ver notas a pie.

NS - Non-Serviceable / Non réparable / No reparable LF - Life-Time Filter / Filtro para toda la vida / Filtre à vie

¹¹² Requires two (2). ⁴³⁷ Requires replacement of the complete fuel pump/fuel filter module.



VOLKSWAGEN (cont'd)

2002

Golf, GTI

4 cyl. 1.8L FI Turbo	VO-15	VA-138	VCA-1026	
4 cyl. 1.9L Diesel Turbo FI	VO-71	VA-138	VCA-1026	
4 cyl. 2.0L FI	VO-15	VA-138	VCA-1026	
V6 2.8L FI (AFP)	VO-150	VA-138	VCA-1026	
V6 2.8L FI (BDF)	VO-77	VA-138	VCA-1026	

Jetta, GLI

4 cyl. 1.8L FI Turbo	VO-15	VA-138	VCA-1026	
4 cyl. 1.9L Diesel Turbo	VO-71	VA-138	VCA-1026	
4 cyl. 2.0L FI	VO-15	VA-138	VCA-1026	
V6 2.8L FI (AFP)	VO-150	VA-138	VCA-1026	
V6 2.8L FI (BDF)	VO-77	VA-138	VCA-1026	

Passat

4 cyl. 1.8L FI Turbo	VO-15	VA-157	VCA-1026	
V6 2.8L FI	VO-93	VA-157	VCA-1026	
W8 4.0L FI	VO-150	VA-157	VCA-1026	

2001

Beetle

4 cyl. 1.8L FI Turbo	VO-15	VA-138	VCA-1026	
4 cyl. 1.9L Diesel Turbo	VO-71	VA-138	VCA-1026	
4 cyl. 2.0L FI	VO-15	VA-138	VCA-1026	

Cabrio

4 cyl. 2.0L FI	VO-15	VA-124	VCA-1026	
----------------	-------	--------	----------	--

Eurovan

V6 2.8L FI (AXK)	VO-77			
------------------	-------	--	--	--

Golf, GTI

4 cyl. 1.8L FI Turbo	VO-15	VA-138	VCA-1026	
4 cyl. 1.9L Diesel Turbo FI	VO-71	VA-138	VCA-1026	
4 cyl. 2.0L FI	VO-15	VA-138	VCA-1026	
V6 2.8L FI	VO-150	VA-138	VCA-1026	

Jetta, GLI

4 cyl. 1.8L FI Turbo	VO-15	VA-138	VCA-1026	
4 cyl. 1.9L Diesel Turbo	VO-71	VA-138	VCA-1026	
4 cyl. 2.0L FI	VO-15	VA-138	VCA-1026	
V6 2.8L FI	VO-150	VA-138	VCA-1026	

Passat

4 cyl. 1.8L FI Turbo	VO-15	VA-157		
V6 2.8L FI	VO-93	VA-157		

2000

Beetle

4 cyl. 1.8L FI Turbo	VO-15	VA-138	VCA-1026	
4 cyl. 1.9L Diesel Turbo	VO-71	VA-138	VCA-1026	
4 cyl. 2.0L FI	VO-15	VA-138	VCA-1026	

Cabrio

4 cyl. 2.0L FI	VO-15	VA-124	VCA-1026	
----------------	-------	--------	----------	--

Eurovan

V6 2.8L FI	VO-150			
------------	--------	--	--	--

Golf, GTI

4 cyl. 1.8L FI Turbo	VO-15	VA-138	VCA-1026	
4 cyl. 1.9L Diesel Turbo FI	VO-71	VA-138	VCA-1026	
4 cyl. 2.0L FI	VO-15	VA-138	VCA-1026	
V6 2.8L FI	VO-150	VA-138	VCA-1026	

Se reporter à table de matière pour les notes en bas de page en français. Utilize el contenido para ver notas a pie.
NS - Non-Serviceable / Non réparable / No reparable LF - Life-Time Filter / Filtro para toda la vida / Filtre à vie



VOLKSWAGEN (cont'd)

2000

Jetta, GLI

4 cyl. 1.8L FI Turbo	VO-15	VA-138	VCA-1026	
4 cyl. 1.9L Diesel Turbo FI	VO-71	VA-138	VCA-1026	
4 cyl. 2.0L FI	VO-15	VA-138	VCA-1026	
V6 2.8L FI	VO-150	VA-138	VCA-1026	

Passat

4 cyl. 1.8L FI Turbo	VO-15	VA-157		
V6 2.8L FI	VO-93	VA-157		

1999

Beetle

4 cyl. 1.8L FI Turbo	VO-15	VA-138	VCA-1026	
4 cyl. 1.9L Diesel Turbo	VO-71	VA-138	VCA-1026	
4 cyl. 2.0L FI	VO-15	VA-138	VCA-1026	

Cabrio

4 cyl. 2.0L FI	VO-15	VA-124		
----------------	-------	--------	--	--

Eurovan

V6 2.8L FI	VO-150			
------------	--------	--	--	--

Golf, GTI

4 cyl. 1.8L FI (Mexico)	VO-15	VA-124	VCA-1026	
4 cyl. 1.9L Diesel Turbo FI	VO-71	VA-138	VCA-1026	
4 cyl. 2.0L FI	VO-15	VA-124	VCA-1026	
V6 2.8L FI	VO-150	VA-124	VCA-1026	

Jetta, GLI

4 cyl. 1.9L Diesel Turbo	VO-71	VA-138	VCA-1026	
4 cyl. 2.0L FI (ABA)	VO-15	VA-124	VCA-1026	
4 cyl. 2.0L FI (AEG)	VO-15	VA-138	VCA-1026	
V6 2.8L FI	VO-150	VA-124	VCA-1026	

Passat

4 cyl. 1.8L FI Turbo	VO-15	VA-157		
V6 2.8L FI	VO-93	VA-157		

1998

Beetle

4 cyl. 1.9L Diesel Turbo	VO-71	VA-138	VCA-1026	
4 cyl. 2.0L FI	VO-15	VA-138	VCA-1026	

Cabrio

4 cyl. 2.0L FI	VO-15	VA-124		
----------------	-------	--------	--	--

Golf, GTI

4 cyl. 1.8L FI (Canada)	VO-15	VA-124	VCA-1026	
4 cyl. 1.9L Diesel Turbo FI	VO-15	VA-124	VCA-1026	
4 cyl. 2.0L FI	VO-15	VA-124	VCA-1026	
V6 2.8L FI	VO-150	VA-124	VCA-1026	

Jetta, GLI

4 cyl. 1.9L Diesel Turbo	VO-15	VA-124	VCA-1026	
4 cyl. 2.0L FI	VO-15	VA-124	VCA-1026	
V6 2.8L FI	VO-150	VA-124	VCA-1026	

Passat

4 cyl. 1.8L FI Turbo	VO-15	VA-157		
V6 2.8L FI	VO-93	VA-157		

1997

Cabrio

4 cyl. 2.0L FI	VO-15	VA-124		
----------------	-------	--------	--	--

Se reporter à table de matière pour les notes en bas de page en français. Utilize el contenido para ver notas a pie.

NS - Non-Serviceable / Non réparable / No reparable LF - Life-Time Filter / Filtro para toda la vida / Filtre à vie



VOLKSWAGEN (cont'd)

1997

Eurovan

5 cyl. 2.4L FI Diesel (Canada)	VO-15			
V6 2.8L FI	VO-150			

Golf, GTI

4 cyl. 1.8L FI	VO-15	VA-124	VCA-1026	
4 cyl. 1.9L Diesel Turbo	VO-15	VA-124	VCA-1026	
4 cyl. 2.0L FI	VO-15	VA-124	VCA-1026	
V6 2.8L FI	VO-150	VA-124	VCA-1026	

Jetta, GLI

4 cyl. 1.9L Diesel Turbo	VO-15	VA-124	VCA-1026	
4 cyl. 2.0L FI	VO-15	VA-124	VCA-1026	
V6 2.8L FI	VO-150	VA-124	VCA-1026	

Passat

4 cyl. 1.9L Diesel Turbo	VO-15			
V6 2.8L FI	VO-150			

1996

Cabrio

4 cyl. 2.0L FI	VO-15	VA-124		
----------------	-------	--------	--	--

Eurovan

5 cyl. 2.4L Diesel (Canada)	VO-15			
5 cyl. 2.5L FI	VO-15			

Golf, GTI

4 cyl. 1.8L FI (Canada)	VO-15	VA-124	VCA-1026	
4 cyl. 1.9L Diesel Turbo (Canada)	VO-15	VA-124	VCA-1026	
4 cyl. 2.0L FI	VO-15	VA-124	VCA-1026	
V6 2.8L FI	VO-150 ^{X014} VO-144 ^{Z014}	VA-124	VCA-1026	

Jetta, GLI

4 cyl. 1.9L Diesel Turbo	VO-15	VA-124	VCA-1026	
4 cyl. 2.0L FI	VO-15	VA-124	VCA-1026	
V6 2.8L FI	VO-150 ^{X014} VO-144 ^{Z014}	VA-124	VCA-1026	

Passat

4 cyl. 1.9L Diesel Turbo	VO-15			
4 cyl. 2.0L FI	VO-15			
V6 2.8L FI	VO-150 ^{X014} VO-144 ^{Z014}			

1995

Cabrio

4 cyl. 2.0L FI	VO-15	VA-124		
----------------	-------	--------	--	--

Corrado

V6 2.8L FI	VO-150 ^{X014} VO-144 ^{Z014}			
------------	--	--	--	--

Eurovan

5 cyl. 2.4L Diesel (Canada)	VO-15			
5 cyl. 2.5L FI	VO-15			

Golf, GTI

4 cyl. 1.8L FI (Canada)	VO-15	VA-124	VCA-1026	
4 cyl. 1.9L Diesel (Canada)	VO-15	VA-124	VCA-1026	
4 cyl. 2.0L FI	VO-15	VA-124	VCA-1026	
V6 2.8L FI	VO-150 ^{X014} VO-144 ^{Z014}	VA-124	VCA-1026	

Se reporter à table de matière pour les notes en bas de page en français. Utilize el contenido para ver notas a pie.

NS - Non-Serviceable / Non réparable / No reparable LF - Life-Time Filter / Filtro para toda la vida / Filtre à vie

^{X014}Plastic endcap version. ^{Z014}Metal endcap version.



VOLKSWAGEN (cont'd)

1995

Jetta, GLI

4 cyl. 1.8L FI (Canada)	VO-15	VA-124	VCA-1026	
4 cyl. 1.9L FI Diesel	VO-15	VA-124	VCA-1026	
4 cyl. 2.0L FI	VO-15	VA-124	VCA-1026	
V6 2.8L FI	VO-150 ^{X014} VO-144 ^{Z014}	VA-124	VCA-1026	

Passat

4 cyl. 1.9L Diesel Turbo	VO-15			
4 cyl. 2.0L FI	VO-15			
V6 2.8L FI	VO-144			

VOLVO

2019

S60

4 cyl. 2.0L	VO-174			NS ⁴³⁷
-------------	--------	--	--	-------------------

S90

4 cyl. 2.0L	VO-174			
4 cyl. 2.0L Hybrid	VO-174			

V90, V90 Cross Country

4 cyl. 2.0L	VO-174			
-------------	--------	--	--	--

XC40

4 cyl. 2.0L Turbo	VO-174			
-------------------	--------	--	--	--

XC60

4 cyl. 2.0L	VO-174			NS ⁴³⁷
-------------	--------	--	--	-------------------

XC90

4 cyl. 2.0L	VO-174			
4 cyl. 2.0L Hybrid	VO-174			

2018

S60

4 cyl. 2.0L	VO-174		VCA-1158 ^{X344} VCA-1108 ^{Z344}	NS ⁴³⁷
-------------	--------	--	--	-------------------

S60 Cross Country

4 cyl. 2.0	VO-174		VCA-1158 ^{X344} VCA-1108 ^{Z344}	
------------	--------	--	--	--

S90

4 cyl. 2.0L	VO-174			
4 cyl. 2.0L Hybrid	VO-174			

V60, V60 Cross Country

4 cyl. 2.0L	VO-174		VCA-1158 ^{X344} VCA-1108 ^{Z344}	
-------------	--------	--	--	--

V90, V90 Cross Country

4 cyl. 2.0L	VO-174			
-------------	--------	--	--	--

XC60

4 cyl. 2.0L	VO-174			NS ⁴³⁷
-------------	--------	--	--	-------------------

XC90

4 cyl. 2.0L	VO-174			
4 cyl. 2.0L Hybrid	VO-174			

2017

S60

4 cyl. 2.0L	VO-174		VCA-1158 ^{X344} VCA-1108 ^{Z344}	NS ⁴³⁷
-------------	--------	--	--	-------------------

Se reporter à table de matière pour les notes en bas de page en français. Utilize el contenido para ver notas a pie.

NS - Non-Serviceable / Non réparable / No reparable LF - Life-Time Filter / Filtro para toda la vida / Filtre à vie

⁴³⁷ Requires replacement of the complete fuel pump/fuel filter module. ^{X014} Plastic endcap version. ^{X344} Dust filter. ^{Z014} Metal endcap version. ^{Z344} Dust and odor filter.



VOLVO (cont'd)

2017

S60 Cross Country

4 cyl. 2.0	VO-174		VCA-1158 ^{X344} VCA-1108 ^{Z344}	
------------	--------	--	--	--

S90

4 cyl. 2.0L	VO-174			
-------------	--------	--	--	--

V60,V60 Cross Country

4 cyl. 2.0L	VO-174		VCA-1158 ^{X344} VCA-1108 ^{Z344}	
-------------	--------	--	--	--

V90, V90 Cross Country

4 cyl. 2.0L	VO-174			
-------------	--------	--	--	--

XC60

4 cyl. 2.0L	VO-174		VCA-1158 ^{X344} VCA-1108 ^{Z344}	NS ⁴³⁷
-------------	--------	--	--	-------------------

XC90

4 cyl. 2.0L	VO-174			
4 cyl. 2.0L Hybrid	VO-174			

2016

S60

4 cyl. 2.0L	VO-174		VCA-1158 ^{X344} VCA-1108 ^{Z344}	NS ⁴³⁷
5 cyl. 2.5L Turbo	VO-85	VA-314	VCA-1158 ^{X344} VCA-1108 ^{Z344}	NS ⁴³⁷
6 cyl. 3.0L Turbo	VO-97	VA-315	VCA-1158 ^{X344} VCA-1108 ^{Z344}	NS ⁴³⁷

S60 Cross Country

4 cyl. 2.5L Turbo	VO-85	VA-314	VCA-1158 ^{X344} VCA-1108 ^{Z344}	
-------------------	-------	--------	--	--

S80

4 cyl. 2.0L Turbo	VO-174		VCA-1158 ^{X344} VCA-1108 ^{Z344}	NS ⁴³⁷
-------------------	--------	--	--	-------------------

V60,V60 Cross Country

4 cyl. 2.0L	VO-174		VCA-1158 ^{X344} VCA-1108 ^{Z344}	
5 cyl. 2.5L Turbo	VO-85	VA-314	VCA-1158 ^{X344} VCA-1108 ^{Z344}	NS ⁴³⁷
6 cyl. 3.0L Turbo	VO-97	VA-315	VCA-1158 ^{X344} VCA-1108 ^{Z344}	NS ⁴³⁷

XC60

4 cyl. 2.0L	VO-174		VCA-1158 ^{X344} VCA-1108 ^{Z344}	NS ⁴³⁷
5 cyl. 2.5L Turbo	VO-85	VA-314	VCA-1158 ^{X344} VCA-1108 ^{Z344}	NS ⁴³⁷
6 cyl 3.0L Turbo	VO-97	VA-315	VCA-1158 ^{X344} VCA-1108 ^{Z344}	NS ⁴³⁷

XC70

4 cyl. 2.0L Turbo	VO-174		VCA-1158 ^{X344} VCA-1108 ^{Z344}	NS ⁴³⁷
5 cyl. 2.5L Turbo	VO-85	VA-314	VCA-1158 ^{X344} VCA-1108 ^{Z344}	NS ⁴³⁷

XC90

4 cyl. 2.0L	VO-174			
4 cyl. 2.0L Hybrid	VO-174			

Se reporter à table de matière pour les notes en bas de page en français. Utilize el contenido para ver notas a pie.

NS - Non-Serviceable / Non réparable / No reparable LF - Life-Time Filter / Filtro para toda la vida / Filtre à vie

⁴³⁷ Requires replacement of the complete fuel pump/fuel filter module. ^{X344}Dust filter. ^{Z344}Dust and odor filter.



VOLVO (cont'd)

2015				
S60				
4 cyl. 2.0L	VO-174		VCA-1158 ^{X344} VCA-1108 ^{Z344}	NS ⁴³⁷
5 cyl. 2.5L Turbo	VO-85	VA-314	VCA-1158 ^{X344} VCA-1108 ^{Z344}	NS ⁴³⁷
6 cyl. 3.0L Turbo	VO-97	VA-315	VCA-1158 ^{X344} VCA-1108 ^{Z344}	NS ⁴³⁷
S80				
4 cyl. 2.0L Turbo	VO-174		VCA-1158 ^{X344} VCA-1108 ^{Z344}	NS ⁴³⁷
6 cyl. 3.0L Turbo	VO-97	VA-315	VCA-1158 ^{X344} VCA-1108 ^{Z344}	NS ⁴³⁷
V60, V60 Cross Country				
4 cyl. 2.0L Turbo	VO-174		VCA-1158 ^{X344} VCA-1108 ^{Z344}	NS ⁴³⁷
5 cyl. 2.5L Turbo	VO-85	VA-314	VCA-1158 ^{X344} VCA-1108 ^{Z344}	NS ⁴³⁷
6 cyl. 3.0L Turbo	VO-97	VA-315	VCA-1158 ^{X344} VCA-1108 ^{Z344}	NS ⁴³⁷
XC60				
4 cyl. 2.0L Turbo	VO-174		VCA-1158 ^{X344} VCA-1108 ^{Z344}	NS ⁴³⁷
5 cyl. 2.5L Turbo	VO-85	VA-314	VCA-1158 ^{X344} VCA-1108 ^{Z344}	NS ⁴³⁷
6 cyl. 3.0L Turbo	VO-97	VA-315	VCA-1158 ^{X344} VCA-1108 ^{Z344}	NS ⁴³⁷
6 cyl. 3.2L	VO-97	VA-315	VCA-1158 ^{X344} VCA-1108 ^{Z344}	NS ⁴³⁷
XC70				
4 cyl. 2.0L Turbo	VO-174		VCA-1158 ^{X344} VCA-1108 ^{Z344}	NS ⁴³⁷
6 cyl. 3.0L Turbo	VO-97	VA-315	VCA-1158 ^{X344} VCA-1108 ^{Z344}	NS ⁴³⁷
6 cyl. 3.2L	VO-97	VA-315	VCA-1158 ^{X344} VCA-1108 ^{Z344}	NS ⁴³⁷
2014				
S60				
5 cyl. 2.5L Turbo	VO-85	VA-314	VCA-1158 ^{X344} VCA-1108 ^{Z344}	NS ⁴³⁷
6 cyl. 3.0L Turbo	VO-97	VA-315	VCA-1158 ^{X344} VCA-1108 ^{Z344}	NS ⁴³⁷
S80				
6 cyl. 3.0L Turbo	VO-97	VA-315	VCA-1158 ^{X344} VCA-1108 ^{Z344}	NS ⁴³⁷
6 cyl. 3.2L	VO-97	VA-315	VCA-1158 ^{X344} VCA-1108 ^{Z344}	NS ⁴³⁷
XC60				
6 cyl. 3.0L Turbo	VO-97	VA-315	VCA-1158 ^{X344} VCA-1108 ^{Z344}	NS ⁴³⁷
6 cyl. 3.2L	VO-97	VA-315	VCA-1158 ^{X344} VCA-1108 ^{Z344}	NS ⁴³⁷

Se reporter à table de matière pour les notes en bas de page en français. Utilize el contenido para ver notas a pie.

NS - Non-Serviceable / Non réparable / No reparable LF - Life-Time Filter / Filtro para toda la vida / Filtre à vie

⁴³⁷ Requires replacement of the complete fuel pump/fuel filter module. ^{X344}Dust filter. ^{Z344}Dust and odor filter.



VOLVO (cont'd)

2014

XC70

6 cyl. 3.0L Turbo	VO-97	VA-315	VCA-1158 ^{X344} VCA-1108 ^{Z344}	
6 cyl. 3.2L	VO-97	VA-315	VCA-1158 ^{X344} VCA-1108 ^{Z344}	

XC90

6 cyl 3.2L	VO-97	VA-354	VCA-1040	
------------	-------	--------	----------	--

2013

C30

5 cyl 2.5L Turbo	VO-85	VA-314	VCA-1172	
------------------	-------	--------	----------	--

C70

5 cyl 2.5L Turbo	VO-85	VA-314	VCA-1172	
------------------	-------	--------	----------	--

S60

5 cyl. 2.5L Turbo	VO-85	VA-314	VCA-1158 ^{X344} VCA-1108 ^{Z344}	NS ⁴³⁷
6 cyl. 3.0L Turbo	VO-97	VA-315	VCA-1158 ^{X344} VCA-1108 ^{Z344}	NS ⁴³⁷

S80

6 cyl 3.0L Turbo	VO-97	VA-315	VCA-1158 ^{X344} VCA-1108 ^{Z344}	NS ⁴³⁷
6 cyl 3.2L	VO-97	VA-315	VCA-1158 ^{X344} VCA-1108 ^{Z344}	NS ⁴³⁷

XC60

6 cyl 3.0L Turbo	VO-97	VA-315	VCA-1158 ^{X344} VCA-1108 ^{Z344}	NS ⁴³⁷
6 cyl 3.2L	VO-97	VA-315	VCA-1158 ^{X344} VCA-1108 ^{Z344}	NS ⁴³⁷

XC70

6 cyl. 3.0L Turbo	VO-97	VA-315	VCA-1158 ^{X344} VCA-1108 ^{Z344}	
6 cyl. 3.2L	VO-97	VA-315	VCA-1158 ^{X344} VCA-1108 ^{Z344}	

XC90

6 cyl 3.2L	VO-97	VA-354	VCA-1040	
------------	-------	--------	----------	--

2012

C30

5 cyl 2.5L Turbo	VO-85	VA-314	VCA-1172	
------------------	-------	--------	----------	--

C70

5 cyl 2.5L Turbo	VO-85	VA-314	VCA-1172	
------------------	-------	--------	----------	--

S60

5 cyl. 2.5L Turbo	VO-85	VA-314	VCA-1158 ^{X344} VCA-1108 ^{Z344}	NS ⁴³⁷
6 cyl. 3.0L Turbo	VO-97	VA-315	VCA-1158 ^{X344} VCA-1108 ^{Z344}	

S80

6 cyl 3.0L Turbo	VO-97	VA-315	VCA-1158 ^{X344} VCA-1108 ^{Z344}	NS ⁴³⁷
6 cyl 3.2L	VO-97	VA-315	VCA-1158 ^{X344} VCA-1108 ^{Z344}	NS ⁴³⁷

XC60

6 cyl 3.0L Turbo	VO-97	VA-315	VCA-1158 ^{X344} VCA-1108 ^{Z344}	
------------------	-------	--------	--	--

Se reporter à table de matière pour les notes en bas de page en français. Utilize el contenido para ver notas a pie.

NS - Non-Serviceable / Non réparable / No reparable. LF - Life-Time Filter / Filtro para toda la vida / Filtre à vie

⁴³⁷ Requires replacement of the complete fuel pump/fuel filter module. ^{X344}Dust filter. ^{Z344}Dust and odor filter.



VOLVO (cont'd)

	Oil	Air	Cabin*	Fuel
2012				
XC60				
6 cyl 3.2L	VO-97	VA-315	VCA-1158 ^{X344} VCA-1108 ^{Z344}	
XC70				
6 cyl. 3.0L Turbo	VO-97	VA-315	VCA-1158 ^{X344} VCA-1108 ^{Z344}	
6 cyl. 3.2L	VO-97	VA-315	VCA-1158 ^{X344} VCA-1108 ^{Z344}	
XC90				
6 cyl 3.2L	VO-97	VA-354	VCA-1040	
2011				
C30				
5 cyl 2.5L Turbo	VO-85	VA-314	VCA-1172	
C70				
5 cyl 2.5L Turbo	VO-85	VA-314	VCA-1172	
S40				
5 cyl 2.5L Turbo	VO-85	VA-314	VCA-1172	
S60				
6 cyl. 3.0L Turbo	VO-97	VA-315	VCA-1158 ^{X344} VCA-1108 ^{Z344}	NS
S80				
6 cyl 3.0L Turbo	VO-97	VA-315	VCA-1158 ^{X344} VCA-1108 ^{Z344}	NS ⁴³⁷
6 cyl 3.2L FI	VO-97	VA-315	VCA-1158 ^{X344} VCA-1108 ^{Z344}	NS ⁴³⁷
V50				
5 cyl 2.5L Turbo	VO-85	VA-314	VCA-1172	
XC60				
6 cyl 3.0L Turbo	VO-97	VA-315	VCA-1158 ^{X344} VCA-1108 ^{Z344}	
6 cyl 3.2L	VO-97	VA-315	VCA-1158 ^{X344} VCA-1108 ^{Z344}	
XC70				
6 cyl. 3.0L Turbo	VO-97	VA-315	VCA-1158 ^{X344} VCA-1108 ^{Z344}	
6 cyl. 3.2L	VO-97	VA-315	VCA-1158 ^{X344} VCA-1108 ^{Z344}	
XC90				
6 cyl 3.2L	VO-97	VA-354	VCA-1040	
V8 4.4L	VO-66		VCA-1040	
2010				
C30				
5 cyl 2.4L FI (Canada)	VO-85	VA-314	VCA-1172	
5 cyl 2.5L Turbo	VO-85	VA-314	VCA-1172	
C70				
5 cyl 2.5L Turbo	VO-85	VA-314	VCA-1172	
S40				
5 cyl. 2.4L	VO-85	VA-314	VCA-1172	
5 cyl 2.5L Turbo	VO-85	VA-314	VCA-1172	
S80				
6 cyl 3.0L Turbo	VO-97	VA-315	VCA-1158 ^{X344} VCA-1108 ^{Z344}	NS ⁴³⁷

Se reporter à table de matière pour les notes en bas de page en français. Utilize el contenido para ver notas a pie.

NS - Non-Serviceable / Non réparable / No reparable LF - Life-Time Filter / Filtro para toda la vida / Filtre à vie

⁴³⁷ Requires replacement of the complete fuel pump/fuel filter module. ^{X344}Dust filter. ^{Z344}Dust and odor filter.



VOLVO (cont'd)

2010

S80

6 cyl 3.2L	VO-97	VA-315	VCA-1158 ^{X344} VCA-1108 ^{Z344}	NS ⁴³⁷
V8 4.4L	VO-66		VCA-1158 ^{X344} VCA-1108 ^{Z344}	NS ⁴³⁷

V50

5 cyl. 2.4L	VO-85	VA-314	VCA-1172	
5 cyl 2.5L Turbo	VO-85	VA-314	VCA-1172	

V70

6 cyl. 3.2L	VO-97	VA-315	VCA-1158 ^{X344} VCA-1108 ^{Z344}	
-------------	-------	--------	--	--

XC60

6 cyl 3.0L Turbo	VO-97	VA-315	VCA-1158 ^{X344} VCA-1108 ^{Z344}	
6 cyl 3.2L	VO-97	VA-315	VCA-1158 ^{X344} VCA-1108 ^{Z344}	

XC70

6 cyl. 3.0L Turbo	VO-97	VA-315	VCA-1158 ^{X344} VCA-1108 ^{Z344}	
6 cyl. 3.2L	VO-97	VA-315	VCA-1158 ^{X344} VCA-1108 ^{Z344}	

XC90

6 cyl 3.2L	VO-97	VA-354	VCA-1040	
V8 4.4L	VO-66		VCA-1040	

2009

C30

5 cyl 2.4L FI (Canada)	VO-85	VA-314	VCA-1172	
5 cyl 2.5L FI Turbo	VO-85	VA-314	VCA-1172	

C70

5 cyl 2.5L FI Turbo	VO-85	VA-314	VCA-1172	
---------------------	-------	--------	----------	--

S40

5 cyl. 2.4L FI	VO-85	VA-314	VCA-1172	
5 cyl 2.5L FI Turbo	VO-85	VA-314	VCA-1172	

S60

5 cyl. 2.4L FI Turbo	VO-66	VA-333 ⁹⁰⁸	VCA-1040	
5 cyl. 2.5L FI Turbo	VO-66	VA-333	VCA-1040	

S80

6 cyl 3.0L FI Turbo	VO-97	VA-315	VCA-1158 ^{X344} VCA-1108 ^{Z344}	NS ⁴³⁷
6 cyl 3.2L FI	VO-97	VA-315	VCA-1158 ^{X344} VCA-1108 ^{Z344}	NS ⁴³⁷
V8 4.4L FI	VO-66		VCA-1158 ^{X344} VCA-1108 ^{Z344}	NS ⁴³⁷

V50

5 cyl. 2.4L FI	VO-85	VA-314	VCA-1172	
5 cyl 2.5L FI Turbo	VO-85	VA-314	VCA-1172	

V70

6 cyl. 3.2L FI	VO-97	VA-315	VCA-1158 ^{X344} VCA-1108 ^{Z344}	
----------------	-------	--------	--	--

XC70

6 cyl. 3.0L Turbo	VO-97	VA-315	VCA-1158 ^{X344} VCA-1108 ^{Z344}	
-------------------	-------	--------	--	--

Se reporter à table de matière pour les notes en bas de page en français. Utilize el contenido para ver notas a pie.

NS - Non-Serviceable / Non réparable / No reparable LF - Life-Time Filter / Filtro para toda la vida / Filtre à vie

⁴³⁷ Requires replacement of the complete fuel pump/fuel filter module. ⁹⁰⁸ Panel air. ^{X344}Dust filter. ^{Z344}Dust and odor filter.



VOLVO (cont'd)

	Oil	Air	Cabin*	Fuel
2009				
XC70				
6 cyl. 3.2L FI	VO-97	VA-315	VCA-1158 ^{X344} VCA-1108 ^{Z344}	
XC90				
6 cyl. 3.2L FI	VO-97	VA-354	VCA-1040	
V8 4.4L FI	VO-66		VCA-1040	
2008				
C30				
5 cyl. 2.4L FI (Canada)	VO-85	VA-314	VCA-1172	
5 cyl. 2.5L FI Turbo	VO-85	VA-314	VCA-1172	
C70				
5 cyl. 2.5L FI Turbo	VO-85	VA-314	VCA-1172	
S40				
5 cyl. 2.4L FI	VO-85	VA-314	VCA-1172	
5 cyl. 2.5L FI Turbo	VO-85	VA-314	VCA-1172	
S60				
5 cyl. 2.4L FI Turbo	VO-66	VA-333 ⁹⁰⁸	VCA-1040	
5 cyl. 2.5L FI Turbo	VO-66	VA-333	VCA-1040	
S80				
6 cyl. 3.0L FI Turbo	VO-97	VA-315	VCA-1158 ^{X344} VCA-1108 ^{Z344}	NS ⁴³⁷
6 cyl. 3.2L FI	VO-97	VA-315	VCA-1158 ^{X344} VCA-1108 ^{Z344}	NS ⁴³⁷
V8 4.4L FI	VO-66		VCA-1158 ^{X344} VCA-1108 ^{Z344}	NS ⁴³⁷
V50				
5 cyl. 2.4L FI	VO-85	VA-314	VCA-1172	
5 cyl. 2.5L FI Turbo	VO-85	VA-314	VCA-1172	
V70				
6 cyl. 3.2L FI	VO-97	VA-315	VCA-1158 ^{X344} VCA-1108 ^{Z344}	
XC70				
6 cyl. 3.2L FI	VO-97	VA-315	VCA-1158 ^{X344} VCA-1108 ^{Z344}	
XC90				
6 cyl. 3.2L FI	VO-97	VA-354	VCA-1040	
V8 4.4L FI	VO-66		VCA-1040	
2007				
C30				
5 cyl. 2.4L FI (Canada)	VO-85	VA-314	VCA-1172	
5 cyl. 2.5L FI Turbo (Canada)	VO-85	VA-314	VCA-1172	
C70				
5 cyl. 2.5L FI Turbo	VO-85	VA-314	VCA-1172	
S40				
5 cyl. 2.4L FI	VO-85	VA-314	VCA-1172	
5 cyl. 2.5L FI Turbo	VO-85	VA-314	VCA-1172	
S60				
5 cyl. 2.4L FI Turbo	VO-66	VA-333	VCA-1040	
5 cyl. 2.5L FI Turbo	VO-66	VA-333	VCA-1040	
S60R				
5 cyl. 2.5L FI Turbo	VO-66		VCA-1040	

Se reporter à table de matière pour les notes en bas de page en français. Utilize el contenido para ver notas a pie.

NS - Non-Serviceable / Non réparable / No reparable LF - Life-Time Filter / Filtro para toda la vida / Filtre à vie

⁴³⁷ Requires replacement of the complete fuel pump/fuel filter module. ⁹⁰⁸ Panel air. ^{X344} Dust filter. ^{Z344} Dust and odor filter.



VOLVO (cont'd)

2007

S80

6 cyl 3.2L FI	VO-97	VA-315	VCA-1158 ^{X344} VCA-1108 ^{Z344}	NS ⁴³⁷
V8 4.4L FI	VO-66		VCA-1158 ^{X344} VCA-1108 ^{Z344}	NS ⁴³⁷

V50

5 cyl. 2.4L FI	VO-85	VA-314	VCA-1172	
5 cyl 2.5L FI Turbo	VO-85	VA-314	VCA-1172	

V70

5 cyl. 2.4L FI	VO-66	VA-333	VCA-1040	
5 cyl. 2.5L FI Turbo	VO-66	VA-333	VCA-1040	

V70R

5 cyl. 2.5L FI Turbo	VO-66		VCA-1040	
----------------------	-------	--	----------	--

XC70

5 cyl. 2.5L FI Turbo	VO-66	VA-333	VCA-1040	
----------------------	-------	--------	----------	--

XC90

6 cyl 3.2L FI	VO-97	VA-354	VCA-1040	
V8 4.4L FI	VO-66		VCA-1040	

2006

C70

5 cyl 2.5L FI Turbo	VO-85	VA-314	VCA-1172	
---------------------	-------	--------	----------	--

S40

5 cyl. 2.4L FI	VO-85	VA-314	VCA-1172	
5 cyl 2.5L FI Turbo	VO-85	VA-314	VCA-1172	

S60

5 cyl. 2.4L FI Turbo	VO-66	VA-333	VCA-1040	
5 cyl. 2.5L FI Turbo	VO-66	VA-333	VCA-1040	

S60R

5 cyl. 2.5L FI Turbo	VO-66		VCA-1040	
----------------------	-------	--	----------	--

S80

5 cyl 2.5L FI Turbo	VO-66	VA-350 ^{X533} VA-333 ^{Z533}	VCA-1040	
---------------------	-------	--	----------	--

V50

5 cyl. 2.4L FI	VO-85	VA-314	VCA-1172	
5 cyl 2.5L FI Turbo	VO-85	VA-314	VCA-1172	

V70

5 cyl. 2.4L FI	VO-66	VA-333	VCA-1040	
5 cyl. 2.5L FI Turbo	VO-66	VA-333	VCA-1040	

V70R

5 cyl. 2.5L FI Turbo	VO-66		VCA-1040	
----------------------	-------	--	----------	--

XC70

5 cyl. 2.5L FI Turbo	VO-66	VA-333	VCA-1040	
----------------------	-------	--------	----------	--

XC90

5 cyl 2.5L FI Turbo	VO-66	VA-352	VCA-1040	
V8 4.4L FI	VO-66		VCA-1040	

2005

S40

5 cyl. 2.4L FI	VO-85	VA-314	VCA-1172	
5 cyl 2.5L FI Turbo	VO-85	VA-314	VCA-1172	

S60

5 cyl. 2.4L FI Non Turbo	VO-66	VA-333	VCA-1040	
5 cyl. 2.4L FI Turbo	VO-66	VA-333	VCA-1040	

Se reporter à table de matière pour les notes en bas de page en français. Utilize el contenido para ver notas a pie.

NS - Non-Serviceable / Non réparable / No reparable LF - Life-Time Filter / Filtro para toda la vida / Filtre à vie

⁴³⁷ Requires replacement of the complete fuel pump/fuel filter module. ^{X344} Dust filter. ^{X533} Without California emissions, ^{Z344} Dust and odor filter.

^{Z533} With California emissions.



VOLVO (cont'd)

	Oil	Air	Cabin*	Fuel
2005				
S60				
5 cyl. 2.5L FI Turbo	VO-66	VA-333	VCA-1040	
S60R				
5 cyl. 2.5L FI Turbo	VO-66		VCA-1040	
S80				
5 cyl. 2.5L FI Turbo	VO-66	VA-350 ^{X533} VA-333 ^{Z533}	VCA-1040	
6 cyl. 2.9L FI Turbo	VO-66	VA-350	VCA-1040	
V50				
5 cyl. 2.4L FI	VO-85	VA-314	VCA-1172	
5 cyl. 2.5L FI Turbo	VO-85	VA-314	VCA-1172	
V70				
5 cyl. 2.4L FI Non Turbo	VO-66	VA-333	VCA-1040	
5 cyl. 2.4L FI Turbo	VO-66	VA-333	VCA-1040	
5 cyl. 2.5L FI Turbo	VO-66	VA-333	VCA-1040	
V70R				
5 cyl. 2.5L FI Turbo	VO-66		VCA-1040	
XC70				
5 cyl. 2.5L FI Turbo	VO-66	VA-333	VCA-1040	
XC90				
5 cyl. 2.5L FI Turbo	VO-66	VA-352	VCA-1040	
6 cyl. 2.9L FI Turbo	VO-66	VA-352	VCA-1040	
V8 4.4L FI	VO-66		VCA-1040	
2004				
C70				
5 cyl. 2.3L FI Turbo	VO-66	VFAP-7912	VCA-1040 ^{X180} VCA-1161 ^{Z180}	
5 cyl. 2.4L FI Turbo	VO-66	VFAP-7912	VCA-1040 ^{X180} VCA-1161 ^{Z180}	
S40				
5 cyl. 2.4L FI	VO-85	VA-314	VCA-1172	
5 cyl. 2.5L FI Turbo	VO-85	VA-314	VCA-1172	
S40, V40				
4 cyl. 1.9L FI Turbo	VO-66	VA-90		
S60				
5 cyl. 2.3L FI Turbo	VO-66	VA-333	VCA-1040	
5 cyl. 2.4L FI	VO-66	VA-333	VCA-1040	
5 cyl. 2.5L FI Turbo	VO-66	VA-333	VCA-1040	
S60R				
5 cyl. 2.5L FI Turbo	VO-66		VCA-1040	
S80				
5 cyl. 2.5L FI Turbo	VO-66	VA-350 ^{X533} VA-333 ^{Z533}	VCA-1040	
6 cyl. 2.9L FI Non Turbo	VO-66	VA-350	VCA-1040	
6 cyl. 2.9L FI Turbo	VO-66	VA-350	VCA-1040	
V70				
5 cyl. 2.3L FI Turbo	VO-66	VA-333	VCA-1040	
5 cyl. 2.4L FI	VO-66	VA-333	VCA-1040	
5 cyl. 2.5L FI Turbo	VO-66	VA-333	VCA-1040	
V70R				
5 cyl. 2.5L FI Turbo	VO-66		VCA-1040	

Se reporter à table de matière pour les notes en bas de page en français. Utilize el contenido para ver notas a pie.

NS - Non-Serviceable / Non réparable / No reparable LF - Life-Time Filter / Filtro para toda la vida / Filtre à vie

^{X180}Under dash Dust filter. ^{X533}Without California emissions, ^{Z180}In front of windshield Dust filter. ^{Z533}With California emissions.



VOLVO (cont'd)

2004

XC70

5 cyl. 2.5L FI Turbo	VO-66	VA-333	VCA-1040	
----------------------	-------	--------	----------	--

XC90

5 cyl. 2.5L FI Turbo	VO-66	VA-352	VCA-1040	
----------------------	-------	--------	----------	--

6 cyl. 2.9L FI Turbo	VO-66	VA-352	VCA-1040	
----------------------	-------	--------	----------	--

2003

C70

5 cyl. 2.3L FI Turbo	VO-66	VFAP-7912	VCA-1040 ^{X180}	
----------------------	-------	-----------	--------------------------	--

5 cyl. 2.4L FI Turbo	VO-66	VFAP-7912	VCA-1161 ^{Z180}	
----------------------	-------	-----------	--------------------------	--

			VCA-1040 ^{X180}	
--	--	--	--------------------------	--

			VCA-1161 ^{Z180}	
--	--	--	--------------------------	--

S40, V40

4 cyl. 1.9L FI Turbo	VO-66	VA-90		
----------------------	-------	-------	--	--

S60

5 cyl. 2.3L FI Turbo	VO-66	VA-333	VCA-1040	
----------------------	-------	--------	----------	--

5 cyl. 2.4L FI Non Turbo	VO-66	VA-333	VCA-1040	
--------------------------	-------	--------	----------	--

5 cyl. 2.4L FI Turbo	VO-66	VA-333	VCA-1040	
----------------------	-------	--------	----------	--

5 cyl. 2.5L FI Turbo	VO-66	VA-333	VCA-1040	
----------------------	-------	--------	----------	--

S80

6 cyl. 2.9L FI Non Turbo	VO-66	VA-350	VCA-1040	
--------------------------	-------	--------	----------	--

6 cyl. 2.9L FI Turbo	VO-66	VA-350	VCA-1040	
----------------------	-------	--------	----------	--

V70, V70 Cross Country

5 cyl. 2.3L FI Turbo	VO-66	VA-333	VCA-1040	
----------------------	-------	--------	----------	--

5 cyl. 2.4L FI Non Turbo	VO-66	VA-333	VCA-1040	
--------------------------	-------	--------	----------	--

5 cyl. 2.4L FI Turbo	VO-66	VA-333	VCA-1040	
----------------------	-------	--------	----------	--

5 cyl. 2.5L FI Turbo	VO-66	VA-333	VCA-1040	
----------------------	-------	--------	----------	--

XC90

5 cyl. 2.5L FI Turbo	VO-66	VA-352	VCA-1040	
----------------------	-------	--------	----------	--

6 cyl. 2.9L FI Turbo	VO-66	VA-352	VCA-1040	
----------------------	-------	--------	----------	--

2002

C70

5 cyl. 2.3L FI Turbo	VO-66	VFAP-7912	VCA-1040 ^{X180}	
----------------------	-------	-----------	--------------------------	--

			VCA-1161 ^{Z180}	
--	--	--	--------------------------	--

5 cyl. 2.4L FI Turbo	VO-66	VFAP-7912	VCA-1040 ^{X180}	
----------------------	-------	-----------	--------------------------	--

			VCA-1161 ^{Z180}	
--	--	--	--------------------------	--

S40, V40

4 cyl. 1.9L FI Turbo	VO-66	VA-90		
----------------------	-------	-------	--	--

S60

5 cyl. 2.3L FI Turbo	VO-66	VA-333	VCA-1040	
----------------------	-------	--------	----------	--

5 cyl. 2.4L FI Non Turbo	VO-66	VA-333	VCA-1040	
--------------------------	-------	--------	----------	--

5 cyl. 2.4L FI Turbo	VO-66	VA-333	VCA-1040	
----------------------	-------	--------	----------	--

S80

6 cyl. 2.9L FI Non Turbo	VO-66	VA-350	VCA-1040	
--------------------------	-------	--------	----------	--

6 cyl. 2.9L FI Turbo	VO-66	VA-350	VCA-1040	
----------------------	-------	--------	----------	--

V70, V70 Cross Country

5 cyl. 2.3L FI Turbo	VO-66	VA-333	VCA-1040	
----------------------	-------	--------	----------	--

5 cyl. 2.4L FI Non Turbo	VO-66	VA-333	VCA-1040	
--------------------------	-------	--------	----------	--

5 cyl. 2.4L FI Turbo	VO-66	VA-333	VCA-1040	
----------------------	-------	--------	----------	--

2001

C70

5 cyl. 2.3L FI Turbo	VO-66	VFAP-7912	VCA-1040 ^{X180}	
----------------------	-------	-----------	--------------------------	--

			VCA-1161 ^{Z180}	
--	--	--	--------------------------	--

Se reporter à table de matière pour les notes en bas de page en français. Utilize el contenido para ver notas a pie.

NS - Non-Serviceable / Non réparable / No reparable LF - Life-Time Filter / Filtro para toda la vida / Filtre à vie

^{X180}Under dash Dust filter. ^{Z180}In front of windshield Dust filter.



VOLVO (cont'd)

	Oil	Air	Cabin*	Fuel
2001				
C70				
5 cyl. 2.4L FI Turbo	VO-66	VFAP-7912	VCA-1040 ^{X180} VCA-1161 ^{Z180}	
S40, V40				
4 cyl. 1.9L FI Turbo	VO-66	VA-90		
S60				
5 cyl. 2.3L FI Turbo	VO-66	VA-333	VCA-1040	
5 cyl. 2.4L FI Non Turbo	VO-66	VA-333	VCA-1040	
5 cyl. 2.4L FI Turbo	VO-66	VA-333	VCA-1040	
S80				
6 cyl. 2.8L FI Turbo	VO-66	VA-350	VCA-1040	
6 cyl. 2.9L FI	VO-66	VA-350	VCA-1040	
V70, V70 Cross Country				
5 cyl. 2.3L FI Turbo	VO-66	VA-333	VCA-1040	
5 cyl. 2.4L FI Non Turbo	VO-66	VA-333	VCA-1040	
5 cyl. 2.4L FI Turbo	VO-66	VA-333	VCA-1040	
2000				
C70, S70, V70				
5 cyl. 2.3L FI Turbo	VO-66	VFAP-7912	VCA-1161	
5 cyl. 2.4L FI Non Turbo	VO-66	VFAP-7912	VCA-1161	
5 cyl. 2.4L FI Turbo	VO-66	VFAP-7912	VCA-1161	
S40, V40				
4 cyl. 1.9L FI Turbo	VO-66	VA-90		
S80				
6 cyl. 2.8L FI Turbo	VO-66	VA-350	VCA-1040	
6 cyl. 2.9L FI	VO-66	VA-350	VCA-1040	
1999				
C70, S70, V70				
5 cyl. 2.3L FI Turbo	VO-66	VFAP-7912	VCA-1161	
5 cyl. 2.4L FI Non Turbo	VO-95 ^{X504} VO-25 ^{Z504}	VFAP-7912	VCA-1161	
5 cyl. 2.4L FI Turbo	VO-66	VFAP-7912	VCA-1161	
S80				
6 cyl. 2.8L FI Turbo	VO-66	VA-350	VCA-1040	
6 cyl. 2.9L FI	VO-66	VA-350	VCA-1040	
1998				
C70, S70, V70				
5 cyl. 2.3L FI Turbo	VO-95 ^{X504} VO-25 ^{Z504}	VFAP-7912	VCA-1161	
5 cyl. 2.4L FI Non Turbo	VO-95 ^{X504} VO-25 ^{Z504}	VFAP-7912	VCA-1161	
5 cyl. 2.4L FI Turbo	VO-95 ^{X504} VO-25 ^{Z504}	VFAP-7912	VCA-1161	
S90, V90				
6 cyl. 2.9L FI	VO-95 ^{X504} VO-25 ^{Z504}		VCA-1161	
1997				
850 Series				
5 cyl. 2.3L FI Turbo	VO-95 ^{X504} VO-25 ^{Z504}	VFAP-7912	VCA-1161	
5 cyl. 2.4L FI Non Turbo	VO-95 ^{X504} VO-25 ^{Z504}	VFAP-7912	VCA-1161	

Se reporter à table de matière pour les notes en bas de page en français. Utilize el contenido para ver notas a pie.

NS - Non-Serviceable / Non réparable / No reparable LF - Life-Time Filter / Filtro para toda la vida / Filtre à vie

^{X180}Under dash Dust filter. ^{X504}Alternate ^{Z180}In front of windshield Dust filter. ^{Z504}Primary



VOLVO (cont'd)

1997

850 Series

5 cyl. 2.4L FI Turbo	VO-95 ^{X504} VO-25 ^{Z504}	VFAP-7912	VCA-1161	
----------------------	--	-----------	----------	--

960 Series

6 cyl. 2.9L FI	VO-95 ^{X504} VO-25 ^{Z504}			
----------------	--	--	--	--

S90, V90

6 cyl. 2.9L FI	VO-95 ^{X504} VO-25 ^{Z504}		VCA-1161	
----------------	--	--	----------	--

1996

850 Series

5 cyl. 2.3L FI Turbo	VO-95 ^{X504} VO-25 ^{Z504}	VFAP-7912	VCA-1161	
5 cyl. 2.4L FI	VO-95 ^{X504} VO-25 ^{Z504}	VFAP-7912	VCA-1161	

960 Series

6 cyl. 2.9L FI	VO-95 ^{X504} VO-25 ^{Z504}			
----------------	--	--	--	--

1995

850 Series

5 cyl. 2.3L FI Turbo	VO-95 ^{X504} VO-25 ^{Z504}	VFAP-7912	VCA-1161	
5 cyl. 2.4L FI	VO-95 ^{X504} VO-25 ^{Z504}	VFAP-7912	VCA-1161	

940 Series

4 cyl. 2.3L FI Non Turbo	VO-95 ^{X504} VO-25 ^{Z504}			
4 cyl. 2.3L FI Turbo	VO-95 ^{X504} VO-25 ^{Z504}			

960 Series

6 cyl. 2.9L FI	VO-95 ^{X504} VO-25 ^{Z504}			
----------------	--	--	--	--

WORKHORSE

2005

P30

V8 5.7 350 FI	VO-55	VA-412		
---------------	-------	--------	--	--

2004

P30

V8 5.7 350 FI	VO-55	VA-412		
---------------	-------	--------	--	--

2003

P30

V8 5.7 350 FI	VO-55	VA-412		
---------------	-------	--------	--	--

2002

P30

V8 5.7 350 FI	VO-55	VA-412		
---------------	-------	--------	--	--

2001

P30

V8 5.7 350 FI	VO-55	VA-412		
---------------	-------	--------	--	--

2000

P30

V8 5.7 350 FI	VO-55	VA-412		
---------------	-------	--------	--	--

Se reporter à table de matière pour les notes en bas de page en français. Utilize el contenido para ver notas a pie.

NS - Non-Serviceable / Non réparable / No reparable LF - Life-Time Filter / Filtro para toda la vida / Filtre à vie

^{X504}Alternate ^{Z504}Primary



VPG

2012

MV-1

V8 4.6L

VO-88

2011

MV-1

V8 4.6L

VO-88

Se reporter à table de matière pour les notes en bas de page en français. Utilize el contenido para ver notas a pie.
NS - Non-Serviceable / Non réparable / No reparable LF - Life-Time Filter / Filtro para toda la vida / Filtre à vie

Cross Reference

Table da equivalencias da fabricantes

Code de renvoi au fabricant

MFR'S NUMBER	REPLACEMENT NUMBER	MFR'S NUMBER	REPLACEMENT NUMBER	MFR'S NUMBER	REPLACEMENT NUMBER	MFR'S NUMBER	REPLACEMENT NUMBER	MFR'S NUMBER	REPLACEMENT NUMBER
		A1616C	VA-144	A3076C	VA-360	A3169C	VA-349	A3609C	VA-448
AC DELCO		A1618C	VA-324	A3081C	VA-188	A3170C	VA-264	A3610C	VA-329
A1089C	VA-69	A1621C	VA-169	A3083C	VA-225	A3174C	VA-308	A3611C	VA-204
A1096C	VA-78	A1624C	VA-181	A3085C	VA-271	A3178C	VA-457	A3612C	VA-317
A1103C	VA-321	A1627C	VA-176	A3086C	VA-259	A3181C	VA-259	A3613C	VA-323
A1114C	VA-413	A178CW	VA-402	A3087C	VA-218	A3184C	VA-424	A3614C	VA-337
A1115C	VA-205	A2013C	VA-151	A3088C	VA-186	A3186C	VA-273	A3615C	VA-444
A1129C	VA-269	A2014C	VA-161	A3089C	VA-180	A3190C	VA-278	A3616C	VA-293
A1131C	VA-66	A2029C	VA-335	A3091C	VA-205	A3193C	VA-427	A3617C	VA-400
A1146C	VA-70	A2036C	VA-171	A3095C	VA-219	A3195C	VA-425	A3618C	VA-287
A1163C	VA-108	A2038C	VA-142	A3096C	VA-263	A3197C	VA-468	A3619C	VA-290
A1164C	VA-84	A2040C	VA-140	A3097C	VA-169	A3198C	VA-244	A3620C	VA-179
A1166C	VA-90	A2041C	VA-149	A3099C	VA-388	A3201C	VA-390	A3621C	VA-273
A1195C	VA-88	A2043C	VA-148	A3100C	VA-187	A3201C	VA-468	A3622C	VA-177
A1208C	VA-109	A2044C	VA-153	A3103C	VA-231	A3202C	VA-471	A3623C	VA-310
A1212C	VA-408	A2045C	VA-136	A3104C	VA-209	A3208C	VA-459	A3624C	VA-310
A1229C	VA-414	A2046C	VA-138	A3108C	VA-340	A3212C	VA-467	A3625C	VA-284
A1233C	VA-110	A2047C	VA-146	A3109C	VA-198	A3218C	VA-324	A3626C	VA-288
A1236C	VA-412	A2048C	VA-137	A3110C	VA-202	A3221C	VA-485	A3627C	VA-253
A1251C	VA-83	A2049C	VA-350	A3111C	VA-226	A3226C	VA-474	A3629C	VA-304
A1253C	VA-158	A2050C	VA-190	A3112C	VA-201	A3229C	VA-426	A3630C	VA-305
A1256C	VA-97	A2051C	VA-270	A3113C	VA-212	A3231C	VA-469	A3631C	VA-343
A1267C	VA-105	A2052C	VA-152	A3114C	VA-213	A3238C	VA-255	A3632C	VA-292
A1272C	VA-101	A2053C	VA-150	A3115C	VA-229	A3240C	VA-474	A3634C	VA-297
A1279C	VA-91	A2054C	VA-155	A3116C	VA-230	A3246C	VA-505	A3635C	VA-252
A1282C	VA-99	A2055C	VA-154	A3117C	VA-231	A328C	VA-411	A3636C	VA-275
A1283C	VA-104	A2056C	VA-147	A3118C	VA-214	A329C	VA-403	A3637C	VA-307
A1284C	VFAP-7854	A2057C	VA-410	A3119C	VA-197	A3306C	VA-442	A3639C	VA-242
A1285C	VA-107	A2058C	VA-122	A3120C	VA-247	A3308C	VA-434	A3640C	VA-366
A1286C	VA-102	A2569C	VA-380	A3121C	VA-207	A3311C	VA-396	A3641C	VA-291
A1287C	VA-103	A2611C	VA-394	A3122C	VA-208	A3314C	VA-450	A3642C	VA-300
A1289C	VA-113	A2848C	VA-178	A3123C	VA-194	A3316C	VA-423	A3643C	VA-227
A1290C	VA-124	A2849C	VA-397	A3124C	VA-328	A3317C	VA-435	A3645C	VA-334
A1291C	VA-120	A2931C	VA-167	A3125C	VA-355	A3318C	VA-490	A3646C	VA-358
A1292C	VA-89	A2932C	VA-196	A3126C	VA-399	A3323C	VA-458	A3647C	VA-331
A1298C	VA-112	A2933C	VA-163	A3127C	VA-206	A3334C	VA-286	A3648C	VA-383
A1300C	VA-92	A2934C	VA-165	A3128C	VA-254	A3335C	VA-306	A3649C	VA-240
A1301C	VA-320	A2935C	VA-170	A3129C	VA-199	A3336C	VA-224	A3650C	VA-265
A1307C	VA-93	A2936C	VA-166	A3130C	VA-210	A3337C	VA-432	A3651C	VA-359
A1309C	VA-98	A2937C	VA-156	A3131C	VA-215	A3338C	VA-460	A3652C	VA-228
A1311C	VA-106	A2938C	VA-191	A3132C	VA-341	A3353C	VA-311	A3653C	VA-283
A1313C	VA-370	A2939C	VA-109	A3133C	VA-216	A3354C	VA-455	A3654C	VA-372
A1316C	VA-125	A2940C	VA-177	A3134C	VA-195	A3355C	VA-451	A3655C	VA-261
A1323C	VFAP-7857	A2941C	VA-164	A3135C	VA-248	A3357C	VA-461	A3656C	VA-282
A1329C	VFAP-7859	A2942C	VA-185	A3137C	VA-280	A3358C	VA-462	A3657C	VA-391
A1341C	VA-111	A2943C	VA-160	A3138C	VA-255	A3361C	VA-449	A3659C	VA-363
A1347C	VFAP-7892	A2944C	VA-336	A3140C	VA-381	A3370C	VA-428	A3660C	VA-258
A1388C	VA-338	A2949C	VA-342	A3141C	VA-295	A3371C	VA-303	A3661C	VA-268
A1410C	VFAP-7912	A2950C	VA-183	A3144C	VA-296	A3373C	VA-429	A3665C	VA-309
A1411C	VA-157	A2951C	VA-184	A3145C	VA-285	A3374C	VA-298	A3666C	VA-289
A1413C	VA-128	A2953C	VA-175	A3146C	VA-259	A3376C	VA-463	A3667C	VA-319
A1414C	VFAP-7865	A2954C	VA-322	A3148C	VA-327	A3377C	VA-267	A3668C	VA-362
A1416C	VFAP-1613	A2955C	VA-182	A3149C	VA-375	A3381C	VA-431	A3669C	VA-371
A1417C	VFAP-1612	A2956C	VA-203	A3150C	VA-241	A3383C	VA-465	A3670C	VA-316
A1509C	VA-114	A2957C	VA-162	A3151C	VA-222	A3384C	VA-417	A3673C	VA-278
A1511C	VFAP-7908	A2959C	VA-381	A3152C	VA-382	A3386C	VA-418	A3674C	VA-332
A1512C	VA-135	A2962C	VA-200	A3154C	VA-223	A3388C	VA-445	A3675C	VA-312
A1514C	VA-132	A2964C	VA-192	A3155C	VA-224	A3389C	VA-302	A3676C	VA-244
A1517C	VA-94	A2965C	VA-347	A3156C	VA-246	A3392C	VA-452	A3677C	VA-356
A1545C	VA-131	A2967C	VA-279	A3157C	VA-249	A3393C	VA-438	A3678C	VA-238
A1546C	VFA-1641	A2968C	VA-159	A3158C	VA-243	A3397C	VA-440	A3679C	VA-301
A1547C	VFAP-1643	A2969C	VA-339	A3159C	VA-232	A348C	VA-2	A3683C	VA-368
A1548C	VA-129	A2971C	VA-346	A3160C	VA-233	A3600C	VA-237	A3684C	VA-353
A1549C	VFAP-7893	A2987C	VA-325	A3161C	VA-234	A3601C	VA-390	A3685C	VA-251
A1604C	VA-260	A2990C	VA-172	A3162C	VA-235	A3602C	VA-393	A3686C	VA-257
A1610C	VA-116	A2991C	VA-174	A3163C	VA-236	A3603C	VA-357	A3687C	VA-344
A1611C	VA-117	A2992C	VA-345	A3164C	VA-221	A3604C	VA-351	A3688C	VA-124
A1612C	VA-118	A2997C	VA-193	A3165C	VA-220	A3605C	VA-294	A3689C	VA-274
A1613C	VA-401	A3008C	VA-395	A3166C	VA-245	A3606C	VA-318	A3690C	VA-314
A1613C	VA-96	A3031C	VA-361	A3167C	VA-250	A3607C	VA-365	A3691C	VA-333
A1615C	VA-65	A3054C	VA-217	A3168C	VA-239	A3608C	VA-325	A3692C	VA-315

CAUTION: For general references only. Check catalog for correct filter application. Any use of this interchange to determine filter application is done at the installers risk.
 PRECAUCION: Solamente para referencias generales. Revise el catálogo para la correcta aplicación del filtro. Cualquier uso de la referencia cruzada para determinar la aplicación del filtro es riesgo del instalador. ATTENTION : Seulement pour les références d'ordre général. Contrôler l'application correcte du filtre avec le catalogue. Toute utilisation de moyens afin de déterminer l'application d'un filtre est faite aux risques de l'installateur.

Cross Reference

Table da equivalencias da fabricantes

Code de renvoi au fabricant

MFR'S NUMBER	REPLACEMENT NUMBER	MFR'S NUMBER	REPLACEMENT NUMBER	MFR'S NUMBER	REPLACEMENT NUMBER	MFR'S NUMBER	REPLACEMENT NUMBER	MFR'S NUMBER	REPLACEMENT NUMBER
AC DELCO		CF181	VCA-1078	CF3248	VCA-1047	PF1240	VO-60	PF466G	VO-96
A3693C	VA-352	CF183	VCA-1183	CF3249	VCA-1144	PF1250	VO-88	PF47E	VO-16
A697C	VA-45	CF184	VCA-1183	CF3251C	VCA-1096	PF1250CL	VO-88	PF48	VO-88
A773C	VA-38	CF185	VCA-1184	CF3252	VCA-1048	PF13	VO-95	PF52E	VO-55
A785C	VA-44	CF188	VCA-1173	CF3257	VCA-1053	PF13	VO-95	PF53	VO-25
A858C	VA-40	CF196	VCA-1184	CF3258	VCA-1115	PF13CL	VO-95	PF53CL	VO-25
A917C	VFAP-917	CF197	VCA-1078C	CF3259	VCA-1050	PF13CL	VO-95	PF57	VO-52
A925C	VA-85	CF201	VCA-1184	CF3260C	VCA-1108	PF1409	VO-19	PF60	VO-15
A975C	VA-86	CF202	VCA-1078C	CF3263	VCA-1061	PF1703	VO-80	PF60CL	VO-15
CF101C	VCA-1131	CF2101	VCA-1131	CF3270	VCA-1046	PF1704	VO-81	PF600G	VO-114
CF104	VCA-1003	CF2107	VCA-1008	CF3271	VCA-1094	PF1706	VO-127	PF601G	VO-129
CF107	VCA-1008	CF2108	VCA-1020	CF3272	VCA-1070	PF1707	VO-71	PF602G	VO-141
CF108	VCA-1020	CF2111	VCA-1157	CF3273	VCA-1116	PF1708	VO-77	PF605G	VO-86
CF109	VCA-1030	CF2112	VCA-1001	CF3275	VCA-1064	PF1711	VO-119	PF607G	VO-116
CF110	VCA-1012	CF2142	VCA-1163	CF3276	VCA-1089	PF1766	VO-93	PF609G	VO-92
CF111	VCA-1157	CF2146C	VCA-1168	CF3280	VCA-1153	PF1768	VO-102	PF61E	VO-108
CF112	VCA-1001	CF2220C	VCA-2033	CF3285	VCA-1058	PF1793	VO-106	PF610G	VO-110
CF1125F	VCA-1065	CF2223	VCA-1044	CF3288	VCA-1113	PF2	VO-1	PF614G	VO-128
CF113	VCA-1167	CF2227	VCA-1049	CF3289	VCA-1039	PF2CL	VO-1	PF617G	VO-138
CF1132F	VCA-1002	CF2228	VCA-1104	CF3290	VCA-1038	PF2055	VO-135	PF618G	VO-112
CF1133	VCA-1043	CF2229	VCA-1101	CF3292	VCA-1041	PF2057	VO-106	PF620G	VO-150
CF1135	VCA-1030	CF2230	VCA-1118	CF3293	VCA-1159	PF2111	VO-143	PF624G	VO-166
CF1138F	VCA-1022	CF2231	VCA-1017	CF3294	VCA-1034	PF2114	LC-833	PF625G	VO-138
CF1140	VCA-1022K	CF2232	VCA-1059	CF3295	VCA-1052	PF2129	VO-67	PF626G	VO-109
CF116C	VCA-1150	CF2233	VCA-1102	CF3303	VCA-1114	PF2130	VO-67	PF627G	VO-76
CF1175	VCA-1021	CF2234	VCA-1125	CF3304	VCA-1055	PF2138	VO-162	PF629G	VO-131
CF1177	VCA-1075	CF2255	VCA-1170	CF3305	VCA-1014	PF2139	LC-834	PF63	VO-88
CF1177F	VCA-1075	CF2287	VCA-1077	CF3307	VCA-1155	PF2141	VO-144	PF630G	VO-130
CF1179CF	VCA-1080	CF2288	VCA-1073	CF3308	VCA-1109	PF2145	VO-70	PF632G	VO-121
CF118C	VCA-1165	CF2289	VCA-1093	CF3309	VCA-1134	PF2146	VO-62	PF633G	VO-101
CF1181F	VCA-1078	CF2290	VCA-1097	CF3313	VCA-1172	PF2147	VO-136	PF635G	VO-94
CF1184C	VCA-1078C	CF2291	VCA-1081	CF3314	VCA-1031	PF2174	VO-63	PF637G	VO-151
CF1185	VCA-1184	CF2293	VCA-1177	CF3315	VCA-1031	PF2192	VO-106	PF638G	VO-140
CF1188	VCA-1173	CF2295	VCA-1174	CF3316	VCA-1075	PF2193	VO-150	PF639G	VO-91
CF1196	VCA-1184	CF3110	VCA-1012	CF3317	VCA-1068	PF2195	VO-162	PF64	VO-88
CF1197C	VCA-1078C	CF3113	VCA-1167	CF3318	VCA-1026	PF2203	VO-163	PF65	VO-122
CF1219	VCA-1146	CF3134	VCA-1037	CF3319	VCA-1072	PF2221	VO-118	PF651G	VO-128
CF1236C	VCA-1074	CF3143	VCA-1122	CF3321	VCA-1117	PF2227E	VO-73	PF657G	VO-96
CF125	VCA-1065	CF3144	VCA-1024	CF3323	VCA-1139	PF2232	VO-75	PF658	VO-95
CF126	VCA-1029	CF3145C	VCA-1166	CF3324	VCA-1171	PF2247G	VO-69	PF66	VO-26
CF132	VCA-1002	CF3147	VCA-1068	CF3325C	VCA-1147	PF2248G	LC-8170	PF660	VO-80
CF133	VCA-1043	CF3149C	VCA-1126	CF3340	VCA-1098	PF2249G	VO-74	PF661	VO-106
CF134	VCA-1037	CF3153	VCA-1127	CF3341	VCA-1120	PF2250G	VO-66	PF663	VO-152
CF138	VCA-1022	CF3155	VCA-1161	CF3343	VCA-1110	PF2252G	LC-8445	PF664	VO-19
CF142	VCA-1163	CF3157	VCA-1028	CF3346	VCA-1175	PF2254	VO-86	PF666	VO-124
CF1424	VCA-1029	CF3158	VCA-1060	CF3350	VCA-1115	PF2256G	VO-78	PF668	VO-147
CF143	VCA-1122	CF3159	VCA-1063	CF3351	VCA-1178	PF2257	VO-85	PF67	VO-104
CF144	VCA-1024	CF3160	VCA-1013	CF3352	VCA-1181	PF2257G	VO-98	PF671	VO-25
CF145	VCA-1166	CF3162	VCA-1014	CF3353	VCA-1082	PF2258	VO-82	PF674	VO-35
CF146	VCA-1168	CF3163	VCA-1042	CF3354	VCA-1188	PF2259	VO-84	PF675G	VO-142
CF147	VCA-1068	CF3165	VCA-1067	FB56	VA-48	PF2260	VO-87	PF68	VO-123
CF149	VCA-1106	CF3167	VCA-1123	GF434	VG-2	PF2260G	VO-153	PF680G	VO-168
CF153	VCA-1127	CF3170	VCA-1160	GF510	VG-16	PF2261	VO-90	PF684G	VO-115
CF155	VCA-1161	CF3171C	VCA-1133	GF578	VG-33	PF2262G	VO-172	PF689G	VO-117
CF156	VCA-1040	CF3173	VCA-1031	GF580	VG-30	PF2263G	VO-173	PF69	VO-172
CF157	VCA-1028	CF3201	VCA-1135	GF643	VG-32	PF2264G	VO-98	PF691G	VO-165
CF158	VCA-1060	CF3203C	VCA-1124	GF652	VG-14	PF24	VO-108	PF960	VO-15
CF159	VCA-1063	CF3204	VCA-1124	PFL400A	VO-118	PF25	VO-65	PF963	VO-27
CF160	VCA-1013	CF3211	VCA-1103	PFL400ACL	VO-118	PF26	VO-88	PF964	VO-86
CF162	VCA-1014	CF3212	VCA-1162	PF100G	VO-110	PF35	VO-56	PF970C	VO-35
CF163	VCA-1042	CF3215	VCA-1056	PF1054	VO-46	PF454	VO-65	UPF48R	VO-152
CF165	VCA-1067	CF3237	VCA-1110	PF1070	VO-64	PF457G	VO-76	UPF63R	VO-201
CF166	VCA-1017	CF3238	VCA-1061	PF1072	VO-37	PF457GO	VO-76	UPF64R	VO-160
CF170	VCA-1160	CF3239	VCA-1054	PF1127	VO-106	PF459G	VO-67	96328718	VA-386
CF171	VCA-1133	CF3240	VCA-1138	PF1177	VO-19	PF46E	VO-58	96950990	VA-426
CF173	VCA-1031	CF3241	VCA-1051	PF1218	VO-56	PF460G	VO-97	ALFA-ROMEO	
CF175	VCA-1021	CF3242	VCA-1047	PF1218F	VO-56	PF461G	VO-91	105000603000	VO-1
CF176	VCA-1078C	CF3243	VCA-1035	PF1218F	VO-56	PF462G	VO-111	106000603002	VO-1
CF177	VCA-1075	CF3244	VCA-1066	PF1232	VO-25	PF463G	VO-99	116000603099	VO-95
CF178	VCA-1076	CF3245	VCA-1062	PF1233	VO-40	PF464G	VO-103	116440603000	VO-95
CF179C	VCA-1080	CF3247	VCA-1071	PF1237	VO-106	PF465	VO-101	3706400	VO-1

CAUTION: For general references only. Check catalog for correct filter application. Any use of this interchange to determine filter application is done at the installers risk.

PRECAUCION: Solamente para referencias generales. Revise el catálogo para la correcta aplicación del filtro. Cualquier uso de la referencia cruzada para determinar la aplicación del filtro es riesgo del instalador. ATTENTION : Seulement pour les références d'ordre général. Contrôler l'application correcte du filtre avec le catalogue. Toute utilisation de moyens afin de déterminer l'application d'un filtre est faite aux risques de l'installateur.

Cross Reference

Table da equivalencias da fabricantes

Code de renvoi au fabricant

MFR'S NUMBER	REPLACEMENT NUMBER	MFR'S NUMBER	REPLACEMENT NUMBER	MFR'S NUMBER	REPLACEMENT NUMBER	MFR'S NUMBER	REPLACEMENT NUMBER	MFR'S NUMBER	REPLACEMENT NUMBER	
ALFA-ROMEO										
37064000	VO-1	EAA200	VA-182	AL10955	VO-110	041-0706	VO-52	041-0818	VO-87	
45170000	VO-1	EAA29	VA-90	AL16	VO-95	041-0707	VO-35	041-0819	VO-120	
46519728	VO-52	EAA728	VA-167	AL2	VO-88	041-0708	VO-15	041-0821	VO-97	
60504569	VO-25	EAA74	VA-86	AL2870A	VO-15	041-0711	VO-19	041-0822	VO-96	
60507080	VO-95	EAO11	VO-88	AL3387A	VO-16	041-0711	VO-35	041-0823	VO-106	
60621830	VO-106	EAO11	VO-88	AL3506	VO-58	041-0712	VO-15	041-0824	VO-108	
60621890	VO-106	EAO15	VO-1	AL3593A	VO-106	041-0712	VO-25	041-0825	VO-99	
60810852	VO-106	EAO15	VO-15	AL3600	VO-118	041-0713	VO-135	041-0826	VO-138	
AM GENERAL										
5579680	VO-56	EAO17	VO-201	AL3614	VO-25	041-0714	VO-15	041-0827	VO-129	
AMERICAN MOTORS										
3153230	VO-1	EAO17	VO-88	AL3682	VO-25	041-0718	VO-15	041-0829	VO-25	
3157847	VO-108	EAO17	VO-88	AL3786	VO-63	041-0719	VO-19	041-0830	VO-103	
3157877	VO-56	EAO23	VO-55	AL3976A	VO-64	041-0719	VO-35	041-0831	VO-102	
3161267	VO-108	EAO24	VO-56	AL3980	VO-55	041-0720	VO-106	041-0832	VO-88	
3177601	VO-108	EAO24	VO-56	AL400S	VO-118	041-0722	VO-15	041-0833	VO-58	
3177757	VO-108	EAO34	VO-118	AL4967	VO-40	041-0726	VO-25	041-0834	VO-101	
3181366	VO-108	EAO34	VO-118	AL5	VO-56	041-0730	VO-15	041-0835	LC-834	
3188793	VO-108	EAO34	VO-15	AL5618	VO-86	041-0731	VO-25	041-0835	VO-130	
3193818	VO-108	EAO38	VO-25	AL6607	VO-106	041-0734	VO-106	041-0836	VO-140	
3193898	VO-108	EAO42	VO-95	AL8A	VO-1	041-0735	VO-15	041-0837	VO-67	
3196333	VO-108	EAO42	VO-95	AL8081	LC-8170	041-0736	VO-35	041-0841	VO-88	
3196841	VO-2	EAO52	VO-75	AL820S	VO-87	041-0737	VO-1	041-0842	VO-52	
3198112	VO-108	EAO55	VO-101	AL8316	VO-118	041-0739	VO-19	041-0843	VO-88	
3208320	VO-108	EAO59	VO-65	AL8481	VO-69	041-0739	VO-35	041-0845	VO-96	
3215877	VO-108	EAO59	VO-65	AL8712	VO-66	041-0743	VO-95	041-0846	VO-90	
3222897	VO-108	EAO64	VO-108	AL8765	VO-67	041-0744	VO-95	041-0847	VO-99	
3222899	VO-108	EAO80	VO-64	AL8806	VO-73	041-0749	VO-106	041-0848	VO-139	
3225897	VO-108	EAO98	VO-104	AL8873	VO-65	041-0750	VO-40	041-0849	VO-128	
3232126	VO-108	EAO99	VO-63	AL9018	VO-76	041-0751	VO-25	041-0850	VO-86	
3240511	VO-108	EA15K01	VO-102	AL9100	VO-75	041-0752	VO-19	041-0851	VO-25	
3241398	VO-16	EA15K02	VO-84	AL9549	VO-81	041-0752	VO-35	041-0852	VO-88	
3242397	VO-58	EA15K03	VO-76	AL9641	VO-80	041-0753	VO-106	041-0853	VO-109	
3250334	VO-15	EA15K04	VO-96	AL9911	VO-85	041-0754	VO-106	041-0855	VO-40	
7700730077	VO-35	EA15K05	VO-85	AL9972	VO-84	041-0755	VO-106	041-0865	VO-110	
8060266	VO-35	EA15K06	VO-77	AL9999	VO-90	041-0758	VO-40	041-0869	VO-141	
8121678	VA-403	EA15K07	VO-90	BECK/ARNLEY					VO-40	041-0870
8127168	VO-15	EA15K08	LC-8170	C15390P	VCA-1167	041-0760	VO-52	041-0871	VO-149	
8132313	VO-16	EA15K09	VO-40	C15439P	VCA-1012	041-0761	VO-60	041-0872	VO-131	
8933003509	VO-35	EA15K10	VO-40	041-0233	VO-40	041-0765	VO-25	041-0874	VO-166	
8933004195	VO-35	EA15K12	VO-106	041-0266	VO-25	041-0766	VO-25	041-0876	VO-165	
8953002656	VO-35	EA15K12	VO-106	041-0266	VO-95	041-0767	VO-40	041-0877	VO-117	
8953004383	VA-90	EA15K13	VO-106	041-0324	VO-95	041-0768	VO-106	041-0878	VO-91	
8990499	VO-1	EA15K16	VO-71	041-0332	VO-1	041-0769	VO-106	041-0880	VO-164	
8990688	VO-108	EA15K19	VO-114	041-0332	VO-15	041-0771	VO-143	041-8012	VO-95	
8990837	VO-108	EA15K20	VO-106	041-0365	VO-1	041-0772	VO-15	041-8038	VO-95	
8990873	VO-108	EA15K28	VO-67	041-0423	VO-1	041-0773	VO-86	041-8039	VO-15	
899107	VO-108	EA15K29	VO-16	041-0548	VO-27	041-0774	VO-25	041-8044	VO-27	
8991072	VO-108	EA15K32	VO-58	041-0563	VO-1	041-0775	VO-135	041-8046	VO-15	
8992430	VO-108	EA15K35	VO-98	041-0571	VO-19	041-0777	VO-15	041-8046	VO-25	
8992661	VA-321	EA15K37	VO-110	041-0589	VO-52	041-0778	VO-106	041-8049	VO-86	
8993146	VO-108	EA15K39	VO-103	041-0597	VO-15	041-0779	VO-15	041-8050	VO-15	
927787	VO-1	EA15K39	VO-69	041-0597	VO-25	041-0779	VO-62	041-8052	VO-25	
936406	VO-1	EA15K43	VO-115	041-0605	VO-95	041-0780	VO-40	041-8052	VO-40	
938143	VO-108	EA15K49	VO-87	041-0613	VO-1	041-0783	LC-833	041-8054	VO-35	
944345	VO-108	EA15K50	VO-152	041-0613	VO-1	041-0787	LC-834	041-8055	VO-106	
9485162	VA-402	EA15K50	VO-160	041-0639	VO-106	041-0788	VO-95	041-8056	VO-19	
990359	VO-65	EA15K51	VO-200	041-0639	VO-19	041-0789	VO-106	041-8056	VO-35	
996900	VO-108	EA15K54	VO-88	041-0647	VO-1	041-0791	VO-70	041-8058	VO-118	
999103	VA-321	EA15K51	VO-25	041-0647	VO-15	041-0792	VO-15	041-8059	VO-25	
AMSOIL										
EAA08	VA-78	EA15K54	VO-91	041-0662	VO-86	041-0793	VO-144	041-8062	VO-106	
EAA104	VA-105	EA15K88	VO-81	041-0670	VO-40	041-0795	VO-25	041-8063	VO-16	
EAA123	VA-259	ASTON-MARTIN		041-0688	VO-27	041-0796	VO-16	041-8064	VO-106	
EAA123	VA-271	9501110	VO-1	041-0696	VO-95	041-0797	VO-106	041-8065	VO-40	
EAA123	VA-324	AUTOLITE		041-0698	VO-15	041-0807	VO-118	041-8066	VO-40	
EAA170	VA-154	AL10060	VO-88	041-0699	VO-15	041-0809	VO-106	041-8072	VO-60	
EAA176	VA-160	AL10075	VO-91	041-0699	VO-25	041-0810	VO-76	041-8074	VO-106	
EAA189	VA-264	AL10158	VO-87	041-0703	VO-1	041-0811	VO-82	041-8075	VO-106	
EAA191	VA-94	AL10295	VO-96	041-0703	VO-1	041-0812	VO-106	041-8076	VO-106	
		AL10358	VO-102	041-0703	VO-95	041-0813	VO-88	041-8077	VO-25	
		AL10415	LC-8170	041-0704	VO-15	041-0814	VO-80	041-8078	VO-40	
		AL10515	VO-99	041-0706	VO-106	041-0815	VO-137	041-8088	LC-833	
		AL10575	VO-88	041-0706	VO-19	041-0817	VO-80	041-8089	VO-135	

CAUTION: For general references only. Check catalog for correct filter application. Any use of this interchange to determine filter application is done at the installers risk.
 PRECAUCION: Solamente para referencias generales. Revise el catálogo para la correcta aplicación del filtro. Cualquier uso de la referencia cruzada para determinar la aplicación del filtro es riesgo del instalador. ATTENTION : Seulement pour les références d'ordre général. Contrôler l'application correcte du filtre avec le catalogue. Toute utilisation de moyens afin de déterminer l'application d'un filtre est faite aux risques de l'installateur.

Cross Reference

Table da equivalencias da fabricantes

Code de renvoi au fabricant

MFR'S NUMBER	REPLACEMENT NUMBER	MFR'S NUMBER	REPLACEMENT NUMBER	MFR'S NUMBER	REPLACEMENT NUMBER	MFR'S NUMBER	REPLACEMENT NUMBER	MFR'S NUMBER	REPLACEMENT NUMBER
BECK/ARNLEY		041-8814	VO-95	042-1604	VA-347	042-1714	VA-212	042-1818	VA-291
041-8092	VO-35	041-8822	VO-40	042-1607	VA-394	042-1715	VA-362	042-1819	VA-275
041-8093	VO-15	041-8970	VO-95	042-1608	VA-339	042-1716	VA-214	042-1821	VA-396
041-8095	VO-118	041-8988	VO-25	042-1609	VA-146	042-1718	VA-209	042-1823	VA-391
041-8098	VO-95	041-8988	VO-40	042-1610	VA-270	042-1719	VA-353	042-1825	VA-292
041-8100	VO-95	041-8996	VO-118	042-1611	VA-132	042-1720	VA-244	042-1826	VA-390
041-8103	LC-834	042-0323	VA-69	042-1612	VA-260	042-1721	VA-282	042-1827	VA-297
041-8106	LC-8445	042-0794	VA-321	042-1619	VA-90	042-1722	VA-314	042-1829	VA-138
041-8109	VO-127	042-0885	VA-321	042-1620	VA-191	042-1725	VA-274	042-1831	VA-302
041-8127	VO-144	042-1354	VA-69	042-1622	VFAP-7865	042-1726	VA-318	042-1832	VA-307
041-8129	VO-150	042-1364	VA-86	042-1623	VA-152	042-1729	VA-251	042-1840	VA-443
041-8135	VO-106	042-1420	VA-40	042-1624	VA-190	042-1732	VA-326	042-1848	VA-442
041-8136	VO-106	042-1427	VA-84	042-1625	VA-150	042-1733	VA-210	042-1865	VA-423
041-8137	VO-95	042-1429	VA-408	042-1626	VA-399	042-1734	VA-238	042-1867	VA-449
041-8139	VO-15	042-1434	VA-389	042-1628	VA-165	042-1735	VA-235	042-1870	VA-450
041-8140	VO-15	042-1438	VA-38	042-1629	VA-193	042-1736	VA-233	042-1872	VA-301
041-8141	VO-15	042-1445	VA-84	042-1630	VA-170	042-1739	VA-343	042-1876	VA-392
041-8142	VO-143	042-1463	VA-414	042-1631	VA-361	042-1740	VA-357	042-1877	VA-365
041-8143	VO-15	042-1469	VA-408	042-1633	VA-166	042-1741	VA-289	042-1879	VA-452
041-8145	VO-95	042-1488	VA-96	042-1634	VA-192	042-1742	VA-356	042-1881	VA-444
041-8146	VO-70	042-1492	VA-261	042-1637	VA-346	042-1743	VA-237	042-1882	VA-419
041-8148	VO-25	042-1493	VA-83	042-1638	VA-196	042-1744	VA-374	042-1883	VA-437
041-8149	LC-8170	042-1494	VA-416	042-1639	VA-172	042-1745	VA-247	042-1884	VA-246
041-8150	VO-25	042-1495	VA-66	042-1640	VA-185	042-1746	VA-224	042-1886	VA-105
041-8151	VO-106	042-1497	VA-401	042-1644	VA-345	042-1747	VA-181	042-1888	VA-435
041-8152	VO-16	042-1501	VA-158	042-1645	VA-279	042-1748	VA-234	042-1891	VA-448
041-8153	VO-62	042-1503	VA-370	042-1647	VA-171	042-1752	VA-373	042-1906	VA-466
041-8156	VO-93	042-1508	VA-97	042-1648	VA-163	042-1753	VA-278	042-1907	VA-331
041-8157	VO-74	042-1510	VA-395	042-1649	VA-270	042-1754	VA-252	042-2003	VCA-1058
041-8159	VO-1	042-1513	VA-44	042-1650	VA-149	042-1755	VA-332	042-2008	VCA-1026
041-8161	VO-15	042-1515	VA-98	042-1651	VA-325	042-1759	VA-315	042-2012	VCA-1127
041-8162	VO-25	042-1519	VA-99	042-1653	VA-350	042-1760	VA-249	042-2013	VCA-1161
041-8163	VO-106	042-1522	VA-104	042-1657	VA-333	042-1761	VA-372	042-2014	VCA-1014
041-8164	VO-25	042-1523	VA-102	042-1659	VA-196	042-1762	VA-383	042-2015	VCA-1012
041-8165	VO-60	042-1524	VA-103	042-1660	VA-206	042-1763	VA-371	042-2016	VCA-1167
041-8167	VO-71	042-1535	VA-125	042-1663	VA-194	042-1764	VA-215	042-2017	VCA-1013
041-8169	VO-69	042-1536	VFAP-7865	042-1664	VA-161	042-1765	VA-154	042-2018	VCA-1139
041-8170	VO-15	042-1537	VFAP-7892	042-1666	VA-328	042-1766	VA-316	042-2019	VCA-1060
041-8172	VO-143	042-1538	VFAP-7859	042-1667	VA-183	042-1769	VA-445	042-2023	VCA-1063
041-8173	VO-16	042-1541	VFAP-7859	042-1668	VA-204	042-1770	VA-354	042-2024	VCA-1014
041-8174	VO-118	042-1542	VA-387	042-1669	VA-363	042-1771	VA-184	042-2025	VCA-1028
041-8175	VO-86	042-1549	VA-106	042-1670	VA-247	042-1772	VA-221	042-2026	VCA-1042
041-8176	VO-106	042-1550	VFAP-7857	042-1671	VA-195	042-1773	VA-220	042-2027	VCA-1067
041-8177	VO-119	042-1554	VA-113	042-1675	VA-199	042-1775	VA-368	042-2028	VCA-1040
041-8178	VO-66	042-1556	VA-338	042-1676	VA-359	042-1776	VA-176	042-2031	VCA-1122
041-8179	VO-77	042-1558	VA-157	042-1677	VA-184	042-1777	VA-309	042-2032	VCA-1056
041-8180	VO-15	042-1559	VA-124	042-1680	VA-355	042-1778	VA-323	042-2033	VCA-1124
041-8181	VO-106	042-1560	VFAP-7892	042-1681	VA-333	042-1781	VA-364	042-2034	VCA-1162
041-8182	VO-128	042-1561	VFAP-7912	042-1682	VA-190	042-1782	VA-444	042-2035	VCA-1162
041-8183	VO-25	042-1564	VA-128	042-1683	VA-154	042-1787	VA-313	042-2036	VCA-1156
041-8184	VO-85	042-1571	VA-147	042-1685	VA-105	042-1788	VA-351	042-2038	VCA-1096
041-8185	VO-85	042-1572	VFAP-7893	042-1686	VA-193	042-1789	VA-202	042-2041	VCA-1026
041-8186	VO-150	042-1574	VFAP-7912	042-1687	VA-204	042-1791	VA-294	042-2044	VCA-1135
041-8187	VO-86	042-1576	VFAP-7892	042-1688	VA-340	042-1794	VA-448	042-2045	VCA-1070
041-8189	VO-92	042-1577	VA-144	042-1689	VA-202	042-1798	VA-234	042-2046	VCA-1089
041-8190	VO-84	042-1580	VFAP-7908	042-1690	VA-184	042-1799	VA-446	042-2047	VCA-1068
041-8192	VO-90	042-1581	VA-135	042-1691	VA-386	042-1800	VA-250	042-2049	VCA-1129
041-8195	VO-91	042-1583	VA-131	042-1692	VA-330	042-1801	VA-366	042-2050	VCA-1133
041-8665	VO-86	042-1584	VA-148	042-1693	VA-337	042-1802	VA-378	042-2051	VCA-1159
041-8707	VO-106	042-1586	VA-153	042-1697	VA-227	042-1803	VA-378	042-2052	VCA-1048
041-8707	VO-19	042-1588	VA-114	042-1698	VA-379	042-1804	VA-384	042-2053	VCA-1014
041-8715	VO-52	042-1589	VA-117	042-1700	VA-207	042-1805	VA-385	042-2053	VCA-1113
041-8723	VO-15	042-1590	VA-118	042-1702	VA-377	042-1806	VA-257	042-2054	VCA-1047
041-8723	VO-25	042-1591	VA-341	042-1703	VA-188	042-1807	VA-273	042-2056	VCA-1039
041-8731	VO-15	042-1595	VA-138	042-1705	VA-242	042-1810	VA-358	042-2059	VCA-1160
041-8749	VO-95	042-1596	VA-397	042-1706	VA-243	042-1811	VA-268	042-2060	VCA-1145
041-8756	VO-1	042-1599	VA-108	042-1707	VA-228	042-1812	VA-265	042-2064	VCA-1106
041-8756	VO-1	042-1600	VA-136	042-1708	VA-230	042-1813	VA-283	042-2070	VCA-1103
041-8764	VO-15	042-1601	VA-146	042-1711	VA-231	042-1814	VA-193	042-2074	VCA-1037
041-8764	VO-25	042-1602	VA-159	042-1712	VA-198	042-1815	VA-317	042-2075	VCA-1138
041-8772	VO-15	042-1603	VA-178	042-1713	VA-248	042-1816	VA-319	042-2082	VCA-1031

CAUTION: For general references only. Check catalog for correct filter application. Any use of this interchange to determine filter application is done at the installers risk.

PRECAUCION: Solamente para referencias generales. Revise el catálogo para la correcta aplicación del filtro. Cualquier uso de la referencia cruzada para determinar la aplicación del filtro es riesgo del instalador. ATTENTION : Seulement pour les références d'ordre général. Contrôler l'application correcte du filtre avec le catalogue. Toute utilisation de moyens afin de déterminer l'application d'un filtre est faite aux risques de l'installateur.

Cross Reference

Table da equivalencias da fabricantes

Code de renvoi au fabricant

MFR'S NUMBER	REPLACEMENT NUMBER	MFR'S NUMBER	REPLACEMENT NUMBER	MFR'S NUMBER	REPLACEMENT NUMBER	MFR'S NUMBER	REPLACEMENT NUMBER	MFR'S NUMBER	REPLACEMENT NUMBER
BECK/ARNLEY		11427506677	VO-128	64118391200	VCA-1127	5121WS	VA-140	5305WS	VA-116
042-2083	VCA-1110	11427509208	VO-82	64119070073	VCA-1127	5123WS	VA-150	5306WS	VA-147
042-2084	VCA-1155	11427509430	LC-8170	64119216588	VCA-1127	5125WS	VA-156	5307WS	VA-138
042-2085	VCA-1052	11427510717	VO-74	64311000004	VCA-1162	5126WS	VA-152	5309WS	VA-159
042-2087	VCA-1158	11427511161	VO-128	64311496710	VCA-1056	5131WS	VA-193	5313WS	VA-146
042-2088	VCA-1046	11427512300	LC-8170	64316946628	VCA-1103	5132WS	VA-170	5315WS	VA-149
042-2093	VCA-1051	11427512301	LC-8170	64316946629	VCA-1103	5133WS	VA-155	5317WS	VA-151
042-2095	VCA-1114	11427512446	VO-82	64316962548	VCA-1103	5134WS	VA-162	5321WS	VA-190
042-2103	VCA-1144	11427520269	VO-112	64316962549	VCA-1103	5138WS	VA-196	5323WS	VA-350
042-2109	VCA-1129	11427521008	VO-112	64316962553	VCA-1103	5140WS	VA-171	5324WS	VA-154
042-2111	VCA-1147	11427541827	VO-91	64318361899	VCA-1162	5141WS	VA-363	5325WS	VA-165
042-2113	VCA-1172	11427542021	VO-112	64318409043	VCA-1156	5145WS	VA-270	5326WS	VA-192
042-2120	VCA-1123	11427557012	VO-111	64319069927	VCA-1127	5146WS	VA-183	5329WS	VA-164
042-2124	VCA-1050	11427566327	VO-91	64319071934	VCA-1162	5147WS	VA-184	5331WS	VA-166
042-2128	VCA-1041	11427583220	VO-131	64319071935	VCA-1162	5148WS	VA-194	5333WS	VA-176
042-2136	VCA-1058	11427600089	VO-131	64319142114	VCA-1103	5153WS	VA-197	5334WS	VA-163
042-2137	VCA-1057	11427622446	VO-111	64319142115	VCA-1103	5154WS	VA-249	5335WS	VA-161
042-2140	VCA-1044	11427640862	VO-91	64319313519	VCA-1103	5155WS	VA-215	5336WS	VA-185
042-2141	VCA-1064	11427788454	VO-140	BOSCH		5156WS	VA-208	5338WS	VA-333
042-2143	VCA-1053	11427788460	VO-140	C3736WS	VCA-1133	5159WS	VA-188	5339WS	VA-279
042-2147	VCA-1062	11427788461	VO-140	1987432213	VCA-1142	5160WS	VA-269	5342WS	VA-160
042-2151	VCA-1049	11427833242	VO-130	5002WS	VA-40	5161WS	VA-226	5345WS	VA-175
042-2152	VCA-1117	11427833769	VO-130	5012WS	VA-274	5162WS	VA-213	5346WS	VA-247
042-2153	VCA-1061	11427848321	VO-131	5018WS	VA-191	5163WS	VA-229	5347WS	VA-182
042-2154	VCA-1109	11427854445	VO-91	5020WS	VA-217	5165WS	VA-201	5348WS	VA-206
042-2156	VCA-1038	11427953129	VO-91	5022WS	VA-244	5167WS	VA-343	5351WS	VA-179
042-2157	VCA-1034	11428513377	VO-140	5024WS	VA-233	5168WS	VA-212	5352WS	VA-181
042-2158	VCA-1116	11428570590	VO-166	5030WS	VA-268	5169WS	VA-231	5353WS	VA-180
042-2161	VCA-1125	11428575210	VO-166	5031WS	VA-290	5170WS	VA-210	5356WS	VA-195
042-2163	VCA-1104	11428583898	VO-169	5035WS	VA-300	5171WS	VA-242	5358WS	VA-198
042-2164	VCA-1068	11428683196	VO-91	5036WS	VA-301	5175WS	VA-251	5360WS	VA-228
042-2172	VCA-1126	11429061198	VO-15	5046WS	VA-69	5176WS	VA-224	5361WS	VA-227
042-2173	VCA-1153	13711736675	VA-157	5048WS	VA-66	5184WS	VA-309	5362WS	VA-200
042-2174	VCA-1055	13717521023	VA-364	5050WS	VA-86	5194WS	VA-240	5363WS	VA-248
042-2175	VCA-1096	13717521033	VA-337	5056WS	VA-85	5195WS	VA-246	5364WS	VA-365
042-2179	VCA-1061	13717521037	VA-364	5057WS	VA-205	5197WS	VA-250	5372WS	VA-223
042-2180	VCA-1094	13717521038	VA-337	5060WS	VA-90	5200WS	VA-202	5375WS	VA-214
042-2181	VCA-1115	13717534825	VA-326	5062WS	VA-70	5201WS	VFA-1641	5376WS	VA-232
042-2182	VCA-1071	13717542294	VA-323	5064WS	VA-84	5203WS	VA-257	5377WS	VA-243
042-2183	VCA-1051	13717542545	VA-367	5067WS	VA-414	5204WS	VA-283	5378WS	VA-154
042-2184	VCA-1072	13717548888	VA-373	5070WS	VA-269	5204WS	VA-334	5383WS	VA-356
042-2185	VCA-1075	13717556961	VA-317	5074WS	VA-401	5205WS	VA-275	5385WS	VA-203
042-2186	VCA-1120	13717561235	VA-316	5074WS	VA-96	5213WS	VA-291	5388WS	VA-241
042-2187	VCA-1171	13717568728	VA-447	5075WS	VA-416	5215WS	VA-292	5389WS	VA-235
042-2196	VCA-1122	13717571355	VA-444	5076WS	VA-261	5216WS	VA-390	5390WS	VA-211
042-2197	VCA-1131	13717582908	VA-443	5078WS	VA-83	5220WS	VA-299	5392WS	VA-278
042-2203	VCA-1078C	13717599285	VA-396	5079WS	VA-102	5221WS	VA-237	5396WS	VA-289
042-2204	VCA-1098	13717601868	VA-423	5081WS	VFAP-7854	5226WS	VA-341	5402WS	VA-258
042-2211	VCA-1110	13717602643	VA-490	5082WS	VA-401	5234WS	VA-402	5403WS	VA-236
042-2212	VCA-1082	13717605913	VA-444	5083WS	VA-104	5238WS	VA-44	5404WS	VA-332
042-2214	VCA-1044	13717630911	VA-450	5084WS	VFAP-7892	5245WS	VA-65	5413WS	VA-253
042-2217	VCA-1175	13718507320	VA-450	5086WS	VA-108	5247WS	VA-413	5418WS	VA-294
042-2220	VCA-1054	13718616909	VA-490	5089WS	VA-107	5267WS	VA-340	5420WS	VA-280
042-8335	VA-40	13718632502	VA-488	5090WS	VFAP-7857	5268WS	VA-99	5424WS	VA-273
043-0875	VG-16	13721311880	VA-395	5091WS	VA-106	5269WS	VA-98	5425WS	VA-267
043-0909	VG-14	13721477840	VA-199	5092WS	VFAP-1612	5270WS	VFAP-7859	5426WS	VA-245
043-0989	VG-32	13721491749	VA-355	5093WS	VFAP-1613	5272WS	VA-103	5429WS	VA-265
BMW		13721702158	VA-157	5095WS	VA-113	5275WS	VA-132	5430WS	VA-255
11417676541	VO-166	13721702907	VA-341	5096WS	VA-109	5279WS	VFAP-917	5432WS	VA-288
11421266773	VO-15	13721707050	VA-389	5097WS	VA-110	5280WS	VFAP-7912	5433WS	VA-287
11421427908	LC-8170	13721715880	VA-389	5099WS	VA-93	5282WS	VA-89	5434WS	VA-285
11421432097	LC-8445	13721715881	VA-389	5100WS	VA-120	5283WS	VA-94	5435WS	VA-286
11421709514	LC-833	13721726916	VA-395	5101WS	VA-112	5284WS	VA-114	5436WS	VA-293
11421709865	LC-833	13721730946	VFAP-7865	5102WS	VFAP-7893	5285WS	VA-412	5437WS	VA-220
11421711568	LC-834	13721736562	VA-157	5107WS	VA-129	5287WS	VA-124	5438WS	VA-221
11421716121	LC-8445	13721736675	VA-157	5110WS	VFAP-7908	5291WS	VA-135	5442WS	VA-314
11421716192	LC-8445	13721738462	VFAP-7865	5115WS	VA-117	5293WS	VA-260	5445WS	VA-321
11421727300	LC-833	13721742201	VA-341	5116WS	VA-118	5297WS	VA-131	5460WS	VA-38
11421730389	LC-834	13721744869	VFAP-7865	5117WS	VA-136	5300WS	VA-144	5477WS	VA-88
11421740534	LC-8170	64110008138	VCA-1127	5119WS	VA-397	5302WS	VA-153	5479WS	VA-158
11421745390	VO-74	64118391198	VCA-1127	5120WS	VA-137	5304WS	VA-178	5484WS	VA-207

CAUTION: For general references only. Check catalog for correct filter application. Any use of this interchange to determine filter application is done at the installers risk.
 PRECAUCION: Solamente para referencias generales. Revise el catálogo para la correcta aplicación del filtro. Cualquier uso de la referencia cruzada para determinar la aplicación del filtro es riesgo del instalador. ATTENTION : Seulement pour les références d'ordre général. Contrôler l'application correcte du filtre avec le catalogue. Toute utilisation de moyens afin de déterminer l'application d'un filtre est faite aux risques de l'installateur.

Cross Reference

Table da equivalencias da fabricantes

Code de renvoi au fabricant

MFR'S NUMBER	REPLACEMENT NUMBER	MFR'S NUMBER	REPLACEMENT NUMBER	MFR'S NUMBER	REPLACEMENT NUMBER	MFR'S NUMBER	REPLACEMENT NUMBER	MFR'S NUMBER	REPLACEMENT NUMBER
BOSCH		72200WS	VO-60	3312	VO-106	P3502	VCA-1031	ST3411	VO-90
5486WS	VA-105	72201WS	LC-8445	3313	VO-102	P3600	VCA-1167	ST3421	VO-15
5492WS	VA-92	72202WS	LC-8170	3320	VO-19	P3602	VCA-1041	ST3422	VO-118
5493WS	VA-320	72203WS	VO-73	3321	VO-95	P3610	VCA-1157	ST3423	VO-108
5494WS	VFAP-7865	72204WS	VO-103	3322	VO-65	P3620	VCA-1021	ST3425	VO-118
5498WS	VA-339	72206WS	VO-66	3323	VO-106	P3630	VCA-1030	ST3427	VO-109
5499WS	VA-324	72207WS	VO-127	3324	VO-76	P3631	VCA-1058	ST3430	VO-55
5502WS	VA-347	72208WS	VO-71	3325	VO-40	P3640	VCA-1162	ST3441	VO-93
5503WS	VA-172	72209WS	VO-86	3326	VO-73	P3652	VCA-1008	ST3474	VO-67
5508WS	VA-325	72211WS	VO-15	3330	VO-25	P3670	VCA-1029	ST3477	VO-103
5510WS	VA-335	72213WS	VO-119	3331	VO-16	P3671	VCA-1163	ST3502	VO-88
5511WS	VA-177	72214WS	VO-74	3332	VO-58	P3672	VCA-1056	ST3511	VO-75
5520WS	VA-209	72215WS	VO-76	3334	VO-88	P3700	VCA-1161	ST3530	VO-63
5521WS	VA-230	72217WS	VO-77	3335	VO-110	P3701	VCA-1014	ST3547	LC-8170
5524WS	VA-238	72218WS	VO-94	3400	VO-25	P3702	VCA-1160	ST3581	VO-85
5526WS	VA-252	72219WS	VO-124	3401	VO-35	P3704	VCA-1170	ST3848	VO-99
5535WS	VA-254	72223WS	VO-82	3402	VO-95	P3706	VCA-1089	ST3953	VO-104
5537WS	VA-296	72224WS	VO-128	3410	VO-88	P3710	VCA-1020	ST3972	VO-84
5538WS	VA-296	72225WS	VO-85	3410	VO-88	P3711	VCA-1012	CARQUEST	
5539WS	VA-157	72226WS	VO-106	3411	VO-90	P3720	VCA-1002	201170	VA-364
5544WS	VA-2	72227WS	VO-88	3412	VO-66	P3721	VCA-1101	248990	VA-274
5545WS	VA-403	72228WS	VO-106	3421	VO-15	P3725	VCA-1104	248992	VA-365
5554WS	VA-97	72229WS	VO-106	3422	VO-118	P3728	VCA-1060	287306	VA-163
5557WS	VA-338	72230WS	VO-106	3423	VO-108	P3729	VCA-1024	479940	VA-424
5558WS	VA-111	72230WS	VO-40	3425	VO-118	P3730	VCA-1003	479945	VA-308
5560WS	VA-169	72231WS	VO-108	3427	VO-109	P3733	VCA-1129	479946	VA-308
5562WS	VA-189	72232WS	VO-55	3430	VO-55	P3744	VCA-1134	479950	VCA-1082
5572WS	VA-102	72233WS	VO-58	3441	VO-93	P3745	VCA-1051	479962	VCA-1174
5573WS	VA-219	72234WS	VO-88	3474	VO-67	P3746	VCA-1035	504549	VA-460
5576WS	VA-264	72235WS	VO-56	3477	VO-69	P3748	VCA-1022	507633	VCA-1176
5581WS	VA-274	72236WS	VO-84	3480	VO-85	P3749	VCA-1138	518216	VA-430
5589WS	VA-225	72237WS	VO-25	3481	VO-92	P3750	VCA-1042	518217	VA-451
5600WS	VA-304	72238WS	VO-65	3482	VO-115	P3752	VCA-1037	518529	VA-428
5601WS	VA-306	72239WS	VO-80	3483	VO-122	P3752	VCA-1122	524491	VA-453
5602WS	VA-307	72240WS	VO-102	3500	VO-1	P3754	VCA-1028	524493	VA-431
5603WS	VA-308	72241WS	VO-91	3502	VO-88	P3755	VCA-1067	524498	VA-417
5604WS	VA-312	72242WS	VO-81	3510	VO-56	P3756	VCA-1102	524502	VA-438
5605WS	VA-311	72243WS	VO-63	3511	VO-75	P3760	VCA-1001	527994	VCA-1189
5606WS	VA-426	72244WS	VO-69	3520	VO-64	P3784	VCA-1068	528001	VCA-1061
5607WS	VA-302	72245WS	VO-75	3530	VO-63	P3785	VCA-1014	528428	VA-455
5608WS	VA-303	72246WS	VO-90	3540	VO-81	P3790	VCA-1139	538870	VA-450
5609WS	VA-427	72247WS	VO-67	3547	LC-8170	P3800	VCA-1123	538872	VA-457
5610WS	VA-305	72248WS	VO-88	3581	VO-85	P3802	VCA-1106	540256	VCA-1082
6001C	VCA-1003	72249WS	VO-96	3641	VO-80	P3808	VCA-1065	543270	VA-466
6004C	VCA-1162	72250WS	VO-64	3848	VO-99	P3809	VCA-2033	83000	VA-238
6007C	VCA-1048	72251WS	VO-87	3972	VO-84	P3810	VCA-1169	83001	VA-282
6008C	VCA-1046	72252WS	VO-97	3973	VO-88	P3811	VCA-1172	83004	VA-358
6016C	VCA-1069	72253WS	VO-95	3974	VO-106	P3821	VCA-1127	83005	VA-368
6017C	VCA-1044	72254WS	VO-101	3976	VO-15	P3853	VCA-1026	83006	VA-378
6018C	VCA-1049	72255WS	VO-92	3977	VO-71	P3857	VCA-1040	83009	VA-291
72102WS	VO-1	72256WS	VO-85	3978	VO-86	P3859	VCA-1043	83010	VA-234
72132WS	VO-16	72257WS	VO-109	3979	VO-77	P3860	VCA-1066	83012	VA-198
72137WS	VO-95	72257WS	VO-99	3980	VO-96	P3869	VCA-1125	83014	VA-290
72138WS	VO-95	72258WS	VO-111	3981	VO-87	P3871	VCA-1022	83016	VA-245
72143WS	VO-118	72259WS	VO-112	3982	VO-101	P3875	VCA-1063	83017	VA-288
72150WS	VO-15	72260WS	VO-98	3983	VO-98	P3876	VCA-1124	83018	VA-258
72158WS	VO-135	72261WS	VO-69	3984	VO-129	P3877	VCA-1017	83020	VA-274
72161WS	VO-25	72262WS	VO-138	3986	VO-140	P3890	VCA-1013	83022	VA-300
72165WS	VO-15	72263WS	VO-129	BOSCH PREMIUM CABIN AIR	BOSCH STEELTECH			83023	VA-278
72167WS	VO-40	72266WS	VO-130	C3640	VCA-1162	ST3300	VO-106	83030	VA-234
72172WS	LC-833	72267WS	VO-140	C3723	VCA-1103	ST3307	VO-91	83031	VA-292
72181WS	VO-106	72269WS	VO-137	C3789	VCA-1131	ST3312	VO-106	83034	VA-442
72183WS	VO-143	72270WS	VO-109	C3807	VCA-1135	ST3323	VO-106	83038	VA-301
72184WS	VO-144	72270WS	VO-110	C3821	VCA-1127	ST3324	VO-76	83040	VA-221
72191WS	VO-15	72271WS	VO-106	C3841	VCA-1164	ST3325	VO-40	83041	VA-220
72192WS	LC-834	BOSCH PREMIUM		C3853	VCA-1166	ST3330	VO-25	83042	VA-202
72194WS	VO-62	C3736	VCA-1133	C3854	VCA-1166	ST3331	VO-16	83043	VA-313
72196WS	VO-70	3300	VO-106	C3855	VCA-1150	ST3334	VO-88	83048	VA-310
72197WS	VO-150	3307	VO-91	C3871	VCA-1165	ST3335	VO-110	83049	VA-287
72198WS	VO-95	3310	VO-106	C3872	VCA-1168	ST3400	VO-25	83051	VA-328
72199WS	VO-15	3311	VO-40	C3876	VCA-1124	ST3410	VO-88	83052	VA-227

CAUTION: For general references only. Check catalog for correct filter application. Any use of this interchange to determine filter application is done at the installers risk.

PRECAUCION: Solamente para referencias generales. Revise el catálogo para la correcta aplicación del filtro. Cualquier uso de la referencia cruzada para determinar la aplicación del filtro es riesgo del instalador. ATTENTION : Seulement pour les références d'ordre général. Contrôler l'application correcte du filtre avec le catalogue. Toute utilisation de moyens afin de déterminer l'application d'un filtre est faite aux risques de l'installateur.

Cross Reference

Table da equivalencias da fabricantes

Code de renvoi au fabricant

MFR'S NUMBER	REPLACEMENT NUMBER	MFR'S NUMBER	REPLACEMENT NUMBER	MFR'S NUMBER	REPLACEMENT NUMBER	MFR'S NUMBER	REPLACEMENT NUMBER	MFR'S NUMBER	REPLACEMENT NUMBER
CARQUEST		83270	VA-366	84033	VO-73	84502	VO-88	85334MP	VO-106
83053	VA-216	83285	VA-396	84038	VO-69	84503	VO-25	85334MP	VO-52
83054	VA-211	83288	VA-299	84040	VO-106	84510	VO-106	85342	VO-15
83056	VA-323	83293	VA-354	84040	VO-106	84512	VO-111	85344	VO-106
83057	VA-233	83310	VA-309	84041	VO-96	84521	VO-161	85347	VO-52
83058	VA-252	83314	VA-295	84042	VO-99	84526	VO-110	85348	VO-25
83059	VA-372	83320	VA-257	84045	VO-88	84530	VO-40	85348MP	VO-25
83063	VA-184	83344	VA-315	84046	VO-52	84560	VO-140	85355	VO-93
83064	VA-217	83353	VCA-1050	84047	VO-84	84561	VO-101	85356	VO-106
83065	VA-212	83362	VA-332	84050	VO-109	84563	VO-150	85357	VO-106
83066	VA-360	83400	VA-268	84055	VO-106	84620	VO-64	85361	VO-25
83067	VA-213	83429	VA-219	84059	VO-149	84674	VO-98	85362	VO-95
83069	VA-201	83430	VA-273	84060	VO-88	84712	VO-106	85364	VO-15
83070	VA-235	83450	VA-265	84061	VO-90	84806	VO-97	85365	VO-106
83071	VA-360	83459	VA-388	84062	VO-129	84830	VO-106	85366	VO-40
83073	VA-312	83460	VA-250	84063	VO-88	84899	VO-88	85367	VO-25
83085	VA-374	83461	VA-317	84064	VO-102	85034	VO-15	85369	VO-145
83086	VA-242	83466	VCA-1104	84073	VO-88	85036	VO-55	85372	VO-88
83093	VCA-1093	83468	VA-423	84077	VO-120	85036MP	VO-55	85372MP	VO-88
83094	VA-435	83475	VA-280	84078	VO-103	85040	VO-16	85376	VO-163
83100	VA-383	83480	VA-334	84079	VO-78	85040MP	VO-16	85378	VO-60
83101	VCA-1061	83498	VA-263	84082	VO-76	85042	VO-58	85381	VO-19
83102	VA-236	83530	VA-297	84083	VO-77	85043	VO-155	85389	VO-106
83104	VA-231	83545	VA-367	84090	VO-67	85045	VO-108	85391	VO-25
83110	VA-378	83555	VA-444	84092	VO-106	85046	VO-65	85392	VO-27
83113	VA-230	83570	VA-391	84099	VO-65	85049	VO-108	85393	VO-15
83114	VA-215	83590	VA-426	84099HD	VO-65	85060	VO-56	85394	VO-40
83115	VA-200	83593	VA-446	84141	VO-106	85060MP	VO-56	85395	VO-40
83116	VA-251	83600	VA-384	84143	VO-122	85061	VO-56	85396	VO-40
83117	VA-203	83604	VA-284	84144	VO-110	85061MP	VO-56	85452	VO-15
83119	VA-210	83610	VA-390	84145	VO-40	85067	VO-136	85452MP	VO-15
83120	VA-237	83630	VA-307	84148	VO-25	85068	VO-95	85512	VO-15
83121	VA-202	83634	VA-225	84151	VO-104	85068MP	VO-95	85515	VO-1
83122	VA-365	83640	VA-319	84162	VO-139	85069	VO-65	85515MP	VO-1
83123	VA-357	83651	VA-280	84170	VO-144	85069MP	VO-65	85516	VO-118
83136	VA-382	83670	VA-311	84171	VO-128	85083	VO-52	85516MP	VO-118
83143	VA-448	83700	VCA-1117	84172	VO-143	85084	VO-95	85521	VO-95
83145	VA-222	83704	VA-452	84173	VO-87	85085	VO-95	85522	VO-108
83146	VA-289	83727	VA-255	84175	VO-112	85085MP	VO-95	85522MP	VO-108
83154	VA-381	83728	VA-447	84181	VO-25	85088	VO-15	85525	VO-1
83155	VA-248	83730	VA-285	84186	VO-85	85143	VO-134	85568	VO-106
83156	VA-228	83737	VA-286	84187	VO-85	85145	VO-62	85607	VO-64
83157	VA-343	83739	VA-296	84189	VO-131	85160	LC-834	85607MP	VO-64
83158	VA-296	83746	VA-293	84202	VO-75	85170	VO-144	85626	VO-35
83170	VA-202	83750	VA-304	84203	VO-80	85185	LC-833	85627	VO-156
83172	VA-209	83756	VA-273	84204	VO-92	85186	VO-74	85630	VO-37
83175	VA-243	83760	VA-305	84210	VO-71	85189	VO-95	85649	VO-162
83180	VA-247	83800	VA-385	84211	VO-127	85190	VO-55	85673	VO-162
83184	VA-218	83825	VA-326	84241	VO-124	85191	VO-159	85675	VO-146
83185	VA-353	83830	VA-457	84250	VO-99	85212	VO-150	85734	VO-63
83186	VA-226	83843	VA-318	84254	VO-145	85213	LC-8445	85734MP	VO-63
83187	VA-249	83846	VA-329	84260	VO-121	85215	VO-25	85742	VO-46
83191	VA-240	83873	VA-375	84262	VO-132	85223	LC-8170	85742MP	VO-46
83192	VA-229	83876	VA-349	84279	VO-141	85224	VO-143	85762	VO-118
83200	VA-294	83883	VA-223	84301	VO-118	85226	VO-69	85764	VO-118
83201	VA-253	83886	VA-239	84302	VO-86	85227	VO-119	85775	VO-1
83208	VA-443	83888	VA-373	84303	VO-82	85228	VO-86	85785	VO-25
83210	VA-283	83890	VA-241	84310	VO-96	85231	VO-86	85798	VO-163
83211	VA-393	83893	VA-246	84311	VO-81	85246	VO-70	85833	VO-162
83220	VA-184	83894	VA-254	84314	VO-81	85258	VO-108	86046	VG-2
83223	VA-214	83901	VA-267	84323	No Attached Cap	85287	VO-135	86097	VG-16
83224	VA-351	83902	VA-266	84327	VO-91	85307	VO-95	86097MP	VG-16
83225	VA-244	83907	VA-341	84328	VO-137	85311	VO-95	86296	VG-32
83229	VA-364	83926	VA-154	84329	VO-94	85312	VO-95	86296MP	VG-32
83230	VA-275	83933	VA-232	84330	VO-138	85315	VO-118	86311	VG-33
83235	VA-316	83946	VA-272	84334	VO-106	85324	VO-19	86481	VG-14
83240	VA-445	84000	VO-25	84341	VO-116	85333	VO-15	86481MP	VG-14
83244	VA-327	84002	VO-106	84356	VO-106	85334	VO-106	86484	VG-30
83247	VA-302	84021	VO-66	84371	VO-25	85334	VO-106	87013	VA-181
83250	VA-265	84023	VO-25	84430	VO-95	85334	VO-52	87015	VA-147
83264	VA-427	84029	VO-99	84462	VO-133	85334MP	VO-106	87020	VA-321

CAUTION: For general references only. Check catalog for correct filter application. Any use of this interchange to determine filter application is done at the installers risk.
 PRECAUCION: Solamente para referencias generales. Revise el catálogo para la correcta aplicación del filtro. Cualquier uso de la referencia cruzada para determinar la aplicación del filtro es riesgo del instalador. ATTENTION : Seulement pour les références d'ordre général. Contrôler l'application correcte du filtre avec le catalogue. Toute utilisation de moyens afin de déterminer l'application d'un filtre est faite aux risques de l'installateur.

Cross Reference

Table da equivalencias da fabricantes

Code de renvoi au fabricant

MFR'S NUMBER	REPLACEMENT NUMBER	MFR'S NUMBER	REPLACEMENT NUMBER	MFR'S NUMBER	REPLACEMENT NUMBER	MFR'S NUMBER	REPLACEMENT NUMBER	MFR'S NUMBER	REPLACEMENT NUMBER
CARQUEST		87891	VA-151	88322	VA-170	89048	VCA-1077	89823	VCA-1096
87023	VA-361	87897	VA-90	88327	VA-124	89053	VCA-1120	89826	VCA-1089
87086	VA-185	87972	VA-325	88339	VFAP-1613	89065	VCA-1049	89827	VCA-1156
87088	VA-402	87993	VA-48	88340	VA-346	89068	VCA-1118	89829	VCA-1052
87096	VA-45	88006	VFAP-7859	88349	VFAP-1612	89080	VCA-1071	89853	VCA-1139
87098	VA-2	88017	VA-102	88358	VFAP-7908	89094	VA-111	89854	VCA-1048
87101	VA-403	88018	VA-321	88388	VA-135	89103	VCA-1175	89855	VCA-1159
87133	VA-69	88026	VA-103	88390	VA-120	89118	VCA-1106	89863	VCA-1039
87156	VA-228	88027	VA-97	88398	VA-338	89148	VCA-1116	89864	VCA-1168
87164	VA-247	88028	VA-104	88406	VFAP-1643	89191	VCA-1078C	89865	VCA-1029
87177	VFAP-7912	88030	VA-401	88416	VA-114	89200	VCA-1109	89868	VCA-1164
87181	VA-270	88035	VA-91	88417	VA-93	89201	VCA-1061	89871	VCA-1037
87188	VA-196	88036	VA-44	88418	VA-94	89211	VCA-1183	89872	VCA-1030
87190	VA-342	88040	VA-38	88419	VFA-1641	89212	VCA-1110	89873	VCA-1028
87214	VA-395	88043	VA-408	88425	VA-112	89300	VCA-1062	89875	VCA-1014
87295	VA-157	88044	VA-261	88428	VA-404	89313	VCA-1069	89876	VCA-1017
87306	VA-399	88051	VFAP-7854	88440	VA-92	89322	VCA-1166	89877	VCA-1122
87324	VA-321	88053	VA-370	88441	VA-320	89367	VCA-1059	89878	VCA-1060
87329	VA-164	88057	VA-99	88443	VA-117	89400	VCA-1038	89879	VCA-1054
87333	VA-408	88058	VA-158	88444	VA-118	89419	VCA-1081	89881	VCA-1139
87341	VA-142	88064	VA-83	88462	VA-178	89473	VCA-1162	89882	VCA-1065
87351	VA-380	88077	VA-90	88463	VA-136	89474	VCA-1022K	89883	VCA-1014
87384	VA-137	88080	VA-107	88464	VA-339	89475	VCA-1134	89884	VCA-1125
87385	VA-149	88081	VA-129	88465	VA-159	89477	VCA-1101	89893	VCA-1129
87389	VA-154	88083	VA-98	88472	VA-116	89478	VCA-1056	89894	VCA-1024
87412	VA-333	88086	VA-321	88484	VA-410	89479	VCA-1044	89897	VCA-1013
87461	VA-394	88088	VA-269	88493	VA-279	89482	VCA-1046	89899	VCA-1160
87468	VA-371	88093	VA-88	88503	VA-65	89483	VCA-1031	89900	VCA-1042
87472	VA-138	88095	VFAP-7857	88573	VA-169	89484	VCA-1138	89901	VCA-1067
87476	VA-146	88097	VA-416	88646	VA-191	89488	VCA-1031	89902	VCA-1155
87479	VA-146	88098	VA-106	88648	VA-122	89489	VCA-1135	89903	VCA-1170
87484	VA-162	88105	VFAP-7893	88653	VA-335	89517	VCA-1035	89905	VCA-1133
87486	VA-397	88108	VA-101	88659	VA-114	89524	VCA-1110	89907	VCA-1070
87487	VA-259	88109	VA-125	88673	VA-163	89526	VCA-1144	89909	VCA-2033
87488	VA-271	88116	VA-86	88674	VA-166	89579	VCA-1064	90006PT	VCA-1003
87524	VA-140	88117	VA-108	88677	VA-155	89579	VCA-1070	90008PT	VCA-1167
87551	VA-193	88120	VA-40	88678	VA-324	89590	VCA-1078	90009C	VCA-1166
87564	VA-165	88126	VA-66	88699	VA-156	89600	VCA-1115	90010C	VCA-1124
87612	VA-207	88128	VA-413	88728	VA-167	89619	VCA-1177	90010P	VCA-1124
87625	VA-363	88133	VA-69	88798	VA-347	89673	VCA-1162	90013PT	VCA-1060
87697	VA-411	88134	VA-205	88799	VA-132	89682	VCA-1113	90018PT	VCA-1012
87725	VA-160	88139	VA-65	88802	VA-192	89683	VCA-1041	90023PT	VCA-1021
87727	VA-345	88144	VFAP-917	88803	VA-270	89684	VCA-1047	90027CT	VCA-1164
87728	VA-150	88153	VA-78	88804	VA-182	89685	VCA-1146	90075P	VCA-1145
87729	VA-161	88162	VA-96	88814	VA-205	89686	VCA-1126	90080C	VCA-1162
87731	VA-174	88174	VA-70	88831	VA-183	89687	VCA-1102	90081CT	VCA-1127
87737	VA-379	88180	VA-85	88832	VA-184	89688	VCA-1172	90081PT	VCA-1127
87740	VA-172	88195	VA-144	88834	VA-171	89689	VCA-1066	90090CT	VCA-1096
87749	VA-350	88213	VA-105	88835	VA-330	89752	VCA-1167	90093P	VCA-1106
87750	VA-179	88215	VA-153	88873	VA-206	89753	VCA-1144	90096PT	VCA-1039
87752	VA-377	88221	VA-389	88879	VA-189	89756	VCA-1147	90098P	VCA-1159
87793	VA-149	88242	VA-414	88887	VA-175	89761	VCA-1057	90101P	VCA-1048
87797	VA-152	88244	VA-84	88888	VA-195	89765	VCA-1124	90108PT	VCA-1054
87799	VA-199	88245	VA-148	88889	VA-187	89771	VCA-1157	90111C	VCA-1131
87800	VA-355	88253	VA-260	88902	VA-176	89773	VCA-1001	90118P	VCA-1089
87822	VA-400	88253	VA-322	88914	VA-198	89780	VCA-1002	90118PT	VCA-1089
87823	VA-352	88255	VA-411	88916	VA-356	89782	VCA-1167	90123P	VCA-1156
87825	VA-190	88271	VA-387	88917	VA-269	89805	VCA-1003	90125PT	VCA-1041
87826	VA-340	88272	VA-111	88924	VA-197	89807	VCA-1008	90127P	VCA-1134
87831	VA-188	88273	VFAP-7892	88930	VA-264	89808	VCA-1163	90128PT	VCA-1160
87834	VA-208	88288	VFAP-7859	88935	VA-224	89811	VCA-1021	90130C	VCA-1103
87838	VA-386	88289	VA-89	88938	VA-314	89812	VCA-1022	90146P	VCA-1031
87839	VA-337	88293	VA-111	88975	VA-186	89813	VCA-1165	90149P	VCA-1147
87843	VA-180	88298	VA-132	89012	VCA-1171	89814	VCA-1074	90155P	VCA-1036
87844	VA-202	88301	VA-110	89013	VCA-1075	89815	VCA-1063	90156C	VCA-1135
87846	VA-177	88302	VA-109	89014	VCA-1076	89816	VCA-1020	90157P	VCA-1050
87859	VA-204	88303	VA-113	89015	VCA-1072	89817	VCA-1012	90162P	VCA-1135
87863	VA-362	88308	VA-128	89020	VCA-1038	89818	VCA-1040	90168P	VCA-1014
87864	VA-336	88316	VA-412	89030	VCA-1055	89819	VCA-1161	90174P	VCA-1058
87879	VA-359	88318	VA-131	89036	VCA-1098	89821	VCA-1161	90179P	VCA-1069
87885	VA-194	88320	VFAP-7865	89046	VCA-1094	89822	VCA-1026	90181P	VCA-1022

CAUTION: For general references only. Check catalog for correct filter application. Any use of this interchange to determine filter application is done at the installers risk.

PRECAUCION: Solamente para referencias generales. Revise el catálogo para la correcta aplicación del filtro. Cualquier uso de la referencia cruzada para determinar la aplicación del filtro es riesgo del instalador. ATTENTION : Seulement pour les références d'ordre général. Contrôler l'application correcte du filtre avec le catalogue. Toute utilisation de moyens afin de déterminer l'application d'un filtre est faite aux risques de l'installateur.

Cross Reference

Table da equivalencias da fabricantes

Code de renvoi au fabricant

MFR'S NUMBER	REPLACEMENT NUMBER	MFR'S NUMBER	REPLACEMENT NUMBER	MFR'S NUMBER	REPLACEMENT NUMBER	MFR'S NUMBER	REPLACEMENT NUMBER	MFR'S NUMBER	REPLACEMENT NUMBER
CARQUEST		93962	VCA-1181	R83933	VA-232	R85215	VO-25	R87551	VA-193
90182P	VCA-1057	94001	VO-123	R84002	VO-106	R85223	LC-8170	R87564	VA-165
90183P	VCA-1068	94010	VO-114	R84021	VO-66	R85226	VO-69	R87612	VA-207
90185P	VCA-1101	94021	VO-153	R84021MP	VO-66	R85226MP	VO-69	R87725	VA-160
90195P	VCA-1138	94024	VO-117	R84029	VO-99	R85228	VO-86	R87728	VA-150
90196P	VCA-1110	94033	VO-167	R84033	VO-73	R85231	VO-86	R87729	VA-161
90198P	VCA-1052	94056	VO-165	R84041	VO-96	R85246	VO-70	R87740	VA-172
90199P	VCA-1109	94059	VO-151	R84045	VO-88	R85258	VO-108	R87750	VA-179
90205P	VCA-1046	94103	VO-115	R84047	VO-84	R85311	VO-95	R87793	VA-149
90206P	VCA-1064	94206	VO-142	R84050	VO-109	R85315	VO-118	R87797	VA-152
90207P	VCA-1051	94715	VO-164	R84055	VO-106	R85334	VO-106	R87825	VA-190
90210P	VCA-1144	94716	VO-174	R84060	VO-88	R85334MP	VO-106	R87831	VA-188
90212C	VCA-1108	94717	VO-165	R84061	VO-90	R85342	VO-15	R87834	VA-208
90217P	VCA-1034	94718	VO-166	R84064	VO-102	R85348	VO-25	R87843	VA-180
90218P	VCA-1055	94719	VO-167	R84073	VO-88	R85348MP	VO-25	R87844	VA-202
90220P	VCA-1194	95095	VA-298	R84078	VO-69	R85355	VO-93	R87846	VA-177
90225P	VCA-1068	95096	VA-434	R84079	VO-78	R85356	VO-106	R87885	VA-194
90226P	VCA-1038	95096	VA-502	R84082	VO-76	R85356MP	VO-106	R87891	VA-151
90227P	VCA-1049	95164	VA-331	R84082MP	VO-76	R85361	VO-25	R87972	VA-325
90228P	VCA-1044	95209	VO-166	R84083	VO-77	R85361MP	VO-25	R88006	VFAP-7859
90229P	VCA-1104	95241	VO-174	R84090	VO-67	R85365	VO-106	R88017	VA-102
90231PT	VCA-1053	95256	VA-425	R84092MP	VO-106	R85372	VO-88	R88025	VA-203
90233C	VCA-1153	95261	VA-284	R84099	VO-65	R85372MP	VO-88	R88026	VA-103
90236P	VCA-1117	95271	VA-418	R84099MP	VO-65	R85378	VO-60	R88027	VA-97
90237P	VCA-1072	95296	VA-428	R84145	VO-40	R85381	VO-19	R88028	VA-104
90238P	VCA-1093	95515	VO-164	R84173	VO-87	R85391	VO-25	R88035	VA-91
90240P	VCA-1038	96223	VO-168	R84186	VO-85	R85392	VO-27	R88036	VA-44
90241P	VCA-1116	98220	VA-463	R84187	VO-85	R85393	VO-15	R88040	VA-38
90242P	VCA-1062	CARQUEST RED		R84202	VO-75	R85393MP	VO-15	R88044	VA-261
90244P	VCA-1115	B0252	VO-15	R84202MP	VO-75	R85394	VO-40	R88051	VFAP-7854
90247P	VCA-1061	B6822	VO-25	R84203	VO-80	R85394MP	VO-40	R88057	VA-99
90254P	VCA-1075	R83000	VA-238	R84204	VO-92	R85396	VO-40	R88064	VA-83
90256C	VCA-1078C	R83020	VA-274	R84210	VO-71	R85515	VO-1	R88077	VA-90
90256P	VCA-1078	R83040	VA-221	R84250	VO-99	R85515MP	VO-1	R88080	VA-107
90258P	VCA-1044	R83041	VA-220	R84302	VO-86	R85516	VO-118	R88081	VA-129
90259P	VCA-1076	R83042	VA-202	R84303	VO-82	R85516MP	VO-118	R88083	VA-98
90261P	VCA-1040	R83052	VA-227	R84312	VO-81	R85521	VO-95	R88088	VA-269
90264P	VCA-1094	R83053	VA-216	R84314	VO-81	R85522	VO-108	R88093	VA-88
90266P	VCA-1073	R83057	VA-233	R84327	VO-91	R85522MP	VO-108	R88095	VFAP-7857
90268P	VCA-1171	R83058	VA-252	R84356	VO-106	R85626	VO-35	R88097	VA-416
90269P	VCA-1059	R83063	VA-184	R84502	VO-88	R85630	VO-37	R88098	VA-106
90271P	VCA-1177	R83065	VA-212	R84512	VO-111	R85734	VO-63	R88105	VFAP-7893
90273P	VCA-1118	R83067	VA-213	R84526	VO-110	R85734MP	VO-63	R88108	VA-101
90274P	VCA-1098	R83104	VA-231	R84530	VO-40	R85742	VO-46	R88109	VA-125
90275P	VCA-1071	R83114	VA-215	R84561	VO-101	R87013	VA-181	R88116	VA-86
90280P	VCA-1039	R83115	VA-200	R84620	VO-64	R87015	VA-147	R88117	VA-108
90282P	VCA-1120	R83116	VA-251	R84620MP	VO-64	R87020	VA-321	R88120	VA-40
90284P	VCA-1077	R83117	VA-203	R84674	VO-98	R87086	VA-185	R88126	VA-66
90288P	VCA-1081	R83146	VA-289	R84712	VO-106	R87088	VA-402	R88128	VA-413
90290P	VCA-1129	R83155	VA-248	R84806	VO-97	R87096	VA-45	R88134	VA-205
90292P	VCA-1110	R83156	VA-228	R84899	VO-88	R87098	VA-2	R88139	VA-65
90295C	VCA-1080	R83172	VA-209	R85036	VO-55	R87101	VA-403	R88144	VFAP-917
90296P	VCA-1175	R83175	VA-243	R85036MP	VO-55	R87133	VA-69	R88153	VA-78
90297C	VCA-1183	R83191	VA-240	R85040	VO-16	R87164	VA-247	R88162	VA-96
91129	VCA-1173	R83192	VA-229	R85040MP	VO-16	R87177	VFAP-7912	R88174	VA-70
93000	VA-344	R83210	VA-283	R85042	VO-58	R87181	VA-270	R88180	VA-85
93005	VA-450	R83223	VA-214	R85042MP	VO-58	R87188	VA-196	R88195	VA-144
93006	VA-473	R83225	VA-244	R85060	VO-56	R87295	VA-157	R88213	VA-105
93008	VA-303	R83230	VA-275	R85060MP	VO-56	R87329	VA-164	R88215	VA-153
93022	VA-392	R83250	VA-265	R85068	VO-95	R87333	VA-408	R88242	VA-414
93036	VA-429	R83362	VA-332	R85068MP	VO-95	R87341	VA-142	R88244	VA-84
93039	VA-308	R83430	VA-273	R85069	VO-65	R87384	VA-137	R88253	VA-260
93048	VA-306	R83480	VA-334	R85069MP	VO-65	R87385	VA-149	R88255	VA-411
93050	VA-419	R83498	VA-263	R85085	VO-95	R87389	VA-154	R88272	VA-111
93058	VA-437	R83634	VA-225	R85085MP	VO-95	R87412	VA-333	R88273	VFAP-7892
93085	VA-440	R83727	VA-255	R85088	VO-15	R87472	VA-138	R88288	VFAP-7859
93272	VA-438	R83737	VA-286	R85145	VO-62	R87476	VA-146	R88289	VA-89
93644	VA-431	R83756	VA-273	R85160	LC-834	R87479	VA-146	R88293	VA-111
93645	VA-430	R83883	VA-223	R85186	VO-74	R87484	VA-162	R88301	VA-110
93704	VCA-1193	R83901	VA-267	R85191	VO-15	R87487	VA-259	R88302	VA-109
93887	VA-459	R83926	VA-154	R85212	VO-150	R87524	VA-140	R88303	VA-113

CAUTION: For general references only. Check catalog for correct filter application. Any use of this interchange to determine filter application is done at the installers risk.
 PRECAUCION: Solamente para referencias generales. Revise el catálogo para la correcta aplicación del filtro. Cualquier uso de la referencia cruzada para determinar la aplicación del filtro es riesgo del instalador. ATTENTION : Seulement pour les références d'ordre général. Contrôler l'application correcte du filtre avec le catalogue. Toute utilisation de moyens afin de déterminer l'application d'un filtre est faite aux risques de l'installateur.

Cross Reference

Table da equivalencias da fabricantes

Code de renvoi au fabricant

MFR'S NUMBER	REPLACEMENT NUMBER	MFR'S NUMBER	REPLACEMENT NUMBER	MFR'S NUMBER	REPLACEMENT NUMBER	MFR'S NUMBER	REPLACEMENT NUMBER	MFR'S NUMBER	REPLACEMENT NUMBER
CARQUEST RED		CFA1044	VA-116	CFA1329	VA-212	CFA4	VA-321	CF233	VO-16
R88316	VA-412	CFA1046	VA-70	CFA1331	VA-224	CFA411	VFAP-7893	CF236	VO-106
R88318	VA-131	CFA1052	VA-259	CFA1333	VA-223	CFA412	VFAP-7865	CF237	VO-60
R88320	VFAP-7865	CFA1061	VA-146	CFA1335	VA-238	CFA417	VA-114	CF24	VO-108
R88322	VA-170	CFA1062	VA-136	CFA1337	VA-258	CFA4278	VA-86	CF240	VO-106
R88327	VA-124	CFA1070	VA-152	CFA1338	VA-154	CFA439	VA-120	CF25	VO-65
R88339	VFAP-1613	CFA1072	VA-137	CFA1343	VA-201	CFA445	VA-111	CF279	VO-56
R88349	VFAP-1612	CFA1077	VA-151	CFA1344	VA-220	CFA463	VFAP-1612	CF280	VO-15
R88358	VFAP-7908	CFA1079	VA-142	CFA1347	VA-221	CFA472	VFAP-7865	CF2825	VO-15
R88388	VA-135	CFA1080	VA-122	CFA1348	VA-349	CFA481	VFAP-1613	CF2840	VO-40
R88390	VA-120	CFA1082	VA-150	CFA136	VA-105	CFA484	VA-94	CF2849	VO-52
R88398	VA-338	CFA1083	VA-149	CFA1360	VA-233	CFA509	VA-404	CF2856	VO-19
R88406	VFAP-1643	CFA1084	VA-140	CFA1362	VA-235	CFA513	VA-92	CF2921	VO-19
R88416	VA-114	CFA1101	VA-156	CFA1363	VA-240	CFA6395	VA-84	CF2951	VO-25
R88417	VA-93	CFA1102	VA-193	CFA137	VA-104	CFA67	VA-402	CF2977	VO-35
R88418	VA-94	CFA1103	VA-154	CFA1377	VA-225	CFA805	VA-69	CF299	VO-63
R88419	VFAP-1641	CFA1107	VA-172	CFA1379	VA-244	CFA809	VA-45	CF308	VO-40
R88425	VA-112	CFA1108	VA-155	CFA1380	VA-252	CFA826	VA-38	CF35	VO-56
R88428	VA-404	CFA1109	VA-169	CFA1406	VA-246	CFA838	VA-44	CF3506	VO-58
R88440	VA-92	CFA1112	VA-149	CFA1410	VA-332	CFA8423	VA-260	CF3531	VO-27
R88443	VA-117	CFA1113	VA-170	CFA1414	VA-309	CFA873	VA-65	CF3562	VO-19
R88444	VA-118	CFA1119	VA-324	CFA1423	VA-267	CFA878	VA-205	CF3593	VO-52
R88462	VA-178	CFA1121	VA-165	CFA1430	VA-255	CFA879	VA-413	CF3614	VO-25
R88463	VA-136	CFA1125	VA-78	CFA1434	VA-265	CFA880	VA-66	CF3651A	VO-95
R88465	VA-159	CFA1127	VA-162	CFA1437	VA-266	CFA882	VA-86	CF3682	VO-25
R88472	VA-116	CFA1128	VA-164	CFA1439	VA-275	CFA892	VFAP-917	CF3807	VO-106
R88493	VA-279	CFA1129	VA-269	CFA1440	VA-202	CFA894	VA-408	CF384	VO-25
R88503	VA-65	CFA1130	VA-167	CFA1442	VA-257	CFA897	VA-70	CF385	VO-25
R88573	VA-169	CFA1133	VA-163	CFA1446	VA-245	CFA899	VA-90	CF386	VO-106
R88646	VA-191	CFA1134	VA-196	CFA145	VA-2	CFA91	VA-2	CF391	VO-35
R88653	VA-335	CFA1135	VA-161	CFA1450	VA-283	CFA911	VA-38	CF393	VO-55
R88673	VA-163	CFA1139	VA-160	CFA1453	VA-273	CFA92	VA-403	CF396	VO-37
R88674	VA-166	CFA1156	VA-183	CFA1464	VA-291	CFA925	VA-85	CF397	VO-25
R88677	VA-155	CFA1159	VA-270	CFA1479	VA-288	CFA951	VA-88	CF40	VO-16
R88678	VA-324	CFA1160	VA-192	CFA148	VFAP-7857	CFA953	VA-78	CF402	VO-106
R88699	VA-156	CFA1161	VA-171	CFA1481	VA-292	CFA958	VA-416	CF408	VO-64
R88728	VA-122	CFA1163	VA-176	CFA1484	VA-296	CFA972	VA-261	CF410	VO-40
R88799	VA-132	CFA1198	VA-205	CFA1488	VA-293	CFA974	VA-65	CF413	VO-40
R88802	VA-192	CFA1208	VA-322	CFA1490	VA-286	CFA976	VA-83	CF441	VO-46
R88803	VA-270	CFA1210	VA-177	CFA150	VA-106	CFA977	VA-96	CF45	VO-108
R88804	VA-182	CFA1214	VA-195	CFA1502	VA-300	CFA979	VA-101	CF462	VO-60
R88814	VA-205	CFA1219	VA-182	CFA1511	VA-334	CFA98	VA-107	CF47	VO-16
R88831	VA-183	CFA1220	VA-175	CFA1523	VA-287	CFA981	VA-97	CF477	VO-93
R88832	VA-184	CFA1240	VA-206	CFA1530	VA-295	CFA984	VA-98	CF479	VO-150
R88834	VA-171	CFA1243	VA-188	CFA1531	VA-290	CFA987	VA-102	CF481	VO-74
R88873	VA-206	CFA1246	VA-189	CFA1538	VA-307	CFA988	VA-124	CF482	LC-8170
R88879	VA-189	CFA1250	VA-269	CFA1539	VA-301	CFA990	VA-103	CF483	VO-118
R88887	VA-175	CFA1254	VA-184	CFA1545	VA-304	CFA992	VA-108	CF484	VO-106
R88888	VA-195	CFA1256	VA-207	CFA1548	VA-302	CFA993	VFAP-7854	CF487	VO-108
R88902	VA-176	CFA1257	VA-197	CFA1556	VA-298	CFA994	VA-93	CF489	VO-67
R88914	VA-198	CFA1261	VA-181	CFA1557	VA-306	CFB3525	VA-34	CF490	VO-95
R88917	VA-269	CFA1268	VA-208	CFA1559	VA-312	CFB3631	VA-48	CF493	VO-15
R88924	VA-197	CFA1273	VA-186	CFA157	VA-403	CF1A	VO-1	CF494	VO-25
R88935	VA-224	CFA1280	VA-198	CFA1596	VA-311	CF107	VO-95	CF508	VO-64
R88938	VA-314	CFA1290	VA-132	CFA1620	VA-308	CF110	VO-88	CF509	VO-65
R88975	VA-186	CFA1291	VA-209	CFA190	VA-110	CF113	VO-106	CF51	VO-55
R94010	VO-114	CFA1295	VA-200	CFA209	VA-109	CF115	VO-1	CF510	VO-86
CASITE		CFA1296	VA-215	CFA213	VA-113	CF134	VO-118	CF512	VO-73
CAF1706	VA-260	CFA1298	VA-180	CFA244	VFAP-7892	CF144	VO-19	CF52	VO-55
CFA1014	VFAP-1643	CFA1303	VA-203	CFA258	VFAP-7859	CF157	VO-25	CF522	VO-66
CFA1016	VFA-1641	CFA1304	VA-227	CFA307	VA-89	CF16	VO-95	CF523	VO-106
CFA1026	VA-131	CFA1305	VA-251	CFA313	VA-111	CF164	VO-108	CF524	VO-75
CFA1030	VA-135	CFA1307	VA-231	CFA3441	VA-69	CF18	VO-95	CF529	VO-71
CFA1031	VFAP-7908	CFA1308	VA-214	CFA3492	VA-45	CF196	VO-95	CF530	VO-69
CFA1032	VA-205	CFA1309	VA-248	CFA3559	VA-40	CF2A	VO-1	CF547	VO-106
CFA1034	VA-153	CFA1311	VA-179	CFA3588	VA-38	CF213	VO-118	CF548	VO-76
CFA1037	VA-117	CFA1313	VA-228	CFA361	VA-125	CF213	VO-15	CF553	VO-77
CFA1039	VA-118	CFA1317	VA-229	CFA3647	VA-44	CF222	VO-108	CF558	VO-81
CFA1040	VA-91	CFA1319	VA-154	CFA385	VA-412	CF225	VO-65	CF560	VO-82
CFA1041	VA-144	CFA1323	VA-202	CFA3901	VA-90	CF230	VO-108	CF563	VO-25
CFA1043	VA-66	CFA1326	VA-264	CFA391	VA-112	CF232	VO-58	CF565	VO-106

CAUTION: For general references only. Check catalog for correct filter application. Any use of this interchange to determine filter application is done at the installers risk.

PRECAUCION: Solamente para referencias generales. Revise el catálogo para la correcta aplicación del filtro. Cualquier uso de la referencia cruzada para determinar la aplicación del filtro es riesgo del instalador. ATTENTION : Seulement pour les références d'ordre général. Contrôler l'application correcte du filtre avec le catalogue. Toute utilisation de moyens afin de déterminer l'application d'un filtre est faite aux risques de l'installateur.

Cross Reference

Table da equivalencias da fabricantes

Code de renvoi au fabricant

MFR'S NUMBER	REPLACEMENT NUMBER	MFR'S NUMBER	REPLACEMENT NUMBER	MFR'S NUMBER	REPLACEMENT NUMBER	MFR'S NUMBER	REPLACEMENT NUMBER	MFR'S NUMBER	REPLACEMENT NUMBER
CASITE		CM3387A	VO-16	AF1518	VA-271	AF3595	VA-171	AF4028	VA-357
CF576	VO-25	CM3429	VO-108	AF1519	VA-259	AF3598	VA-186	AF4029	VA-238
CF589	VO-25	CM3531	VO-27	AF1612	VFAP-1612	AF3601	VA-249	AF4030	VA-233
CF594	VO-80	CM3593A	VO-106	AF1613	VFAP-1613	AF3605	VA-313	AF4031	VA-234
CF604	VO-85	CM3600	VO-118	AF1615	VA-94	AF3612	VA-290	AF4033	VA-235
CF607	VO-84	CM3614	VO-25	AF1618	VA-120	AF3617	VA-423	AF4034	VA-278
CF608	VO-64	CM3675	VO-108	AF1624	VA-181	AF3621	VA-453	AF4035	VA-372
CF610	VO-85	CM3682	VO-25	AF1630	VA-404	AF3626	VA-488	AF4038	VA-332
CF613	VO-88	CM3950	VO-19	AF1641	VFA-1641	AF372	VA-414	AF4042	VA-236
CF615	VO-90	CM3970	VO-37	AF1643	VFAP-1643	AF3895	VA-194	AF4044	VA-221
CF618	VO-87	CM3980	VO-55	AF1658	VA-260	AF3896	VA-274	AF4045	VA-220
CF623	VO-88	CM3985	VO-35	AF1679	VA-142	AF3897	VA-318	AF4048	VA-245
CF624	VO-76	CM43	VO-95	AF1688	VA-140	AF3898	VA-329	AF4049	VA-375
CF625	VO-96	CM4386	VO-40	AF1695	VA-162	AF3899	VA-368	AF4051	VA-294
CF627	VO-97	CM4967	VO-40	AF1696	VA-149	AF3904	VA-180	AF4052	VA-383
CF628	VO-129	CM5	VO-56	AF1744	VA-322	AF3905	VA-199	AF4054	VA-384
CF629	VO-92	CM5343	VO-106	AF1754	VA-182	AF3906	VA-355	AF4055	VA-250
CF631	VO-111	CM6552	VO-60	AF178	VA-402	AF3908	VA-367	AF4057	VA-358
CF634	VO-91	CM6607	VO-106	AF1890	VA-241	AF3910	VA-317	AF4058	VA-385
CF636	VO-88	CM7317	VO-106	AF2014	VA-161	AF3917	VA-444	AF4062	VA-268
CF637	VO-88	CM8A	VO-1	AF2340	VA-175	AF3927	VA-443	AF4063	VA-366
CF639	VO-101	CM8316	VO-118	AF2441	VA-247	AF3933	VA-204	AF4064	VA-378
CF640	VO-102	CASTROL SFX		AF2548	VA-342	AF3935	VA-323	AF4065	VA-257
CF641	VO-88	CAS10060	VO-152	AF2771	VA-197	AF3936	VA-365	AF4067	VA-275
CF642	VO-99	CAS10060	VO-160	AF2780	VA-222	AF3938	VA-309	AF4897	VA-253
CF643	VO-98	CAS10060	VO-200	AF2782	VA-382	AF3940	VA-448	AF5185	VA-265
CF651	VO-104	CAS10060	VO-201	AF2785	VA-215	AF3954	VA-187	AF5186	VA-390
CF653	VO-109	CAS10060	VO-88	AF2786	VA-216	AF3955	VA-205	AF5187	VA-283
CF655	VO-25	CAS10060	VO-88	AF2883	VA-223	AF3956	VA-179	AF5189	VA-391
CF656	VO-110	CAS10060	VO-88	AF2884	VA-224	AF3957	VA-328	AF5190	VA-273
CF660	VO-103	CAS16	VO-93	AF2893	VA-246	AF3958	VA-206	AF5191	VA-189
CF669	VO-116	CAS16	VO-95	AF293	VA-86	AF3959	VA-195	AF5192	VA-319
CF694	VO-149	CAS16	VO-95	AF2944	VA-336	AF3960	VA-359	AF5196	VA-291
CF697	VO-114	CAS16	VO-95	AF2956	VA-203	AF3961	VA-330	AF5197	VA-293
CF721	VO-123	CAS2	VO-88	AF2962	VA-200	AF3963	VA-386	AF5198	VA-286
CG1116A	VG-2	CAS2	VO-88	AF3054	VA-217	AF3965	VA-337	AF5199	VA-310
CG247	VG-32	CAS3387A	VO-16	AF3076	VA-360	AF3974	VA-207	AF5200	VA-473
CG258	VG-33	CAS3506	VO-58	AF3083	VA-225	AF3975	VA-188	AF5201	VA-292
CG3727	VG-14	CAS3593A	VO-106	AF3095	VA-219	AF3981	VA-340	AF5205	VA-287
CG3802	VG-16	CAS3600	VO-118	AF3096	VA-263	AF3982	VA-314	AF5206	VA-300
CASTROL		CAS3600	VO-118	AF3128	VA-254	AF3983	VA-251	AF5207	VA-301
CA1010	VO-106	CAS3614	VO-25	AF3138	VA-255	AF3984	VA-198	AF5208	VA-297
CA1010	VO-106	CAS3675	VO-108	AF3139	VA-296	AF3992	VA-202	AF5209	VA-426
CA1020	VO-40	CAS3682	VO-25	AF3148	VA-327	AF3993	VA-208	AF5210	VA-307
CA1030	VO-106	CAS3980	VO-55	AF3171	VA-299	AF3994	VA-248	AF5211	VA-302
CA1040	VO-76	CAS4967	VO-40	AF3173	VA-280	AF3996	VA-209	AF5212	VA-445
CA1050	VO-16	CAS5	VO-56	AF3174	VA-308	AF3997	VA-356	AF5213	VA-392
CA1060	VO-25	CAS5	VO-56	AF3178	VA-457	AF3998	VA-289	AF5216	VA-344
CA1070	VO-106	CAS6607	VO-106	AF3184	VA-424	AF3999	VA-226	AF5217	VA-331
CA1080	VO-58	CAS6607	VO-106	AF3195	VA-425	AF4	VA-321	AF5218	VA-393
CA1090	VO-152	CAS7317	VO-106	AF3201	VA-468	AF4000	VA-227	AF5219	VA-303
CA1090	VO-88	CAS8A	VO-1	AF3202	VA-471	AF4001	VA-228	AF5220	VA-312
CA2010	VO-25	CAS8A	VO-15	AF3212	VA-467	AF4002	VA-210	AF5221	VA-427
CA2020	VO-84	CAS9018	VO-76	AF3216	VA-183	AF4003	VA-201	AF5222	VA-304
CA2030	VO-93	CAS9972	VO-84	AF3217	VA-373	AF4006	VA-362	AF5223	VA-305
CA2030	VO-95	CHAMP		AF3218	VA-364	AF4007	VA-211	AF5224	VA-311
CA2040	VO-88	AF10025	VA-502	AF3219	VA-316	AF4008	VA-212	AF5225	VA-460
CA2040	VO-88	AF10031	VA-503	AF3220	VA-447	AF4010	VA-282	AF5230	VA-419
CA2050	VO-55	AF10032	VA-504	AF3226	VA-474	AF4011	VA-213	AF5231	VA-437
CA2060	VO-118	AF1031	VA-69	AF3245	VA-184	AF4012	VA-229	AF5233	VA-434
CA2070	VO-108	AF1032A	VA-205	AF329	VA-403	AF4014	VA-230	AF5235	VA-438
CA3010	VO-1	AF1042	VA-413	AF348	VA-2	AF4015	VA-231	AF5239	VA-428
CA3010	VO-15	AF1043	VA-66	AF351	VA-84	AF4017	VA-214	AF5240	VA-440
CA3020	VO-56	AF1046	VA-70	AF3588	VA-164	AF4019	VA-242	AF5244	VA-417
CASTROL MAXPRO		AF1061	VA-88	AF3589	VA-185	AF4020	VA-343	AF5245	VA-418
CM13	VO-56	AF1096	VA-78	AF359	VA-408	AF4021	VA-240	AF5246	VA-431
CM16	VO-95	AF1129	VA-269	AF3590	VA-160	AF4022	VA-243	AF5248	VA-432
CM2	VO-88	AF1236	VA-412	AF3591	VA-363	AF4023	VA-244	AF5251	VA-334
CM2825	VO-15	AF1279	VA-91	AF3592	VA-237	AF4025	VA-258	AF5252	VA-485
CM2870A	VO-15	AF1300	VA-92	AF3593	VA-325	AF4026	VA-232	AF5258	VA-455
CM30	VO-65	AF1301	VA-320	AF3594	VA-176	AF4027	VA-252	AF5259	VA-466

CAUTION: For general references only. Check catalog for correct filter application. Any use of this interchange to determine filter application is done at the installers risk.
 PRECAUCION: Solamente para referencias generales. Revise el catálogo para la correcta aplicación del filtro. Cualquier uso de la referencia cruzada para determinar la aplicación del filtro es riesgo del instalador. ATTENTION : Seulement pour les références d'ordre général. Contrôler l'application correcte du filtre avec le catalogue. Toute utilisation de moyens afin de déterminer l'application d'un filtre est faite aux risques de l'installateur.

Cross Reference

Table da equivalencias da fabricantes

Code de renvoi au fabricant

MFR'S NUMBER	REPLACEMENT NUMBER	MFR'S NUMBER	REPLACEMENT NUMBER	MFR'S NUMBER	REPLACEMENT NUMBER	MFR'S NUMBER	REPLACEMENT NUMBER	MFR'S NUMBER	REPLACEMENT NUMBER
CHAMP		AF7910	VA-129	CAF1742K	VCA-1022K	CAF1886P	VCA-1093	PH24	VO-108
AF5263	VA-464	AF7911	VA-144	CAF1743	VCA-1008	CAF1887P	VCA-1071	PH253	VO-95
AF5264	VA-454	AF7912	VFAP-7912	CAF1747	VCA-1160	CAF1890P	VCA-1073	PH2702	VO-60
AF5265	VA-465	AF7913	VA-135	CAF1749	VCA-1010	CAF1891P	VCA-1098	PH2801	VO-35
AF5266	VA-456	AF7914	VA-153	CAF1751	VCA-1042	CAF1896P	VCA-1120	PH2808	VO-106
AF5271	VA-461	AF7917	VA-116	CAF1755	VCA-1020	CAF1897C	VCA-1080	PH2815	VO-15
AF5273	VA-470	AF7918	VA-136	CAF1756	VCA-1163	CAF1898P	VCA-1077	PH2817	VO-27
AF5277	VA-499	AF7919	VA-117	CAF1758	VCA-1012	CAF1899P	VCA-1177	PH2827	VO-25
AF5286	VA-500	AF7920	VA-118	CAF1762	VCA-1030	CAF1900P	VCA-1081	PH2835	VO-25
AF5293	VA-498	AF7935	VA-138	CAF1764	VCA-1028	CAF1903P	VCA-1082	PH2840	VO-40
AF5296	VA-497	AF7938	VA-146	CAF1765	VCA-1037	CAF1904C	VCA-1183	PH2855	VO-135
AF56	VA-48	AF7939	VA-315	CAF1766	VCA-1014	CAF1904P	VCA-1184	PH2856A	VO-19
AF5694	VA-371	AF7942	VA-354	CAF1767	VCA-1106	CAF1907P	VCA-1175	PH2867	VO-106
AF5696	VA-452	AF7943	VA-339	CAF1770	VCA-1013	CAF1908P	VCA-1174	PH2869	VO-106
AF5698	VA-435	AF7944	VA-178	CAF1771	VCA-1024	CAF1911P	VCA-1097	PH2876	VO-106
AF5699	VA-442	AF7946	VA-137	CAF1774	VCA-1067	CAF1914P	VCA-1173	PH2878	VO-175
AF5703	VA-449	AF7949	VA-350	CAF1779	VCA-1043	CAF1918P	VCA-1176	PH2892	VO-143
AF5848	VA-394	AF7953	VA-190	CAF1781	VCA-1063	CAF1921P	VCA-1179	PH2903	VO-52
AF5857	VA-159	AF7954	VA-151	CAF1782	VCA-1129	CAF1924P	VCA-1193	PH2904	VO-95
AF602	VA-40	AF7958	VA-270	CAF1789	VCA-1056	CAF1925P	VCA-1186	PH2905	VO-86
AF6900	VA-267	AF7959	VA-152	CAF1792	VCA-1068	CAF1941P	VCA-1178	PH2992	VO-124
AF6908	VA-288	AF7964	VA-191	CAF1797	VCA-1065	CAF1944P	VCA-1181	PH400	VO-118
AF6910	VA-298	AF7965	VA-150	CAF1800C	VCA-1135	CAF1947P	VCA-1191	PH44	VO-58
AF6928	VA-463	AF7973	VA-341	CAF1801P	VCA-1139	CAF1948P	VCA-1190	PH453	VO-93
AF6935	VA-501	AF7974	VA-166	CAF1802P	VCA-1070	CAF1949P	VCA-1188	PH454	VO-65
AF697	VA-45	AF7975	VA-156	CAF1803C	VCA-1096	CAF1950P	VCA-2035	PH47	VO-16
AF773	VA-38	AF7976	VA-346	CAF1804P	VCA-1048	CAF1953P	VCA-1185	PH48	VO-88
AF7816	VA-96	AF7977	VA-361	CAF1805C	VCA-2033	CAF1957C	VCA-1195	PH488	VO-160
AF7819	VA-401	AF7978	VA-399	CAF1807P	VCA-1102	CAF1961P	VCA-2043	PH500	VO-88
AF7823	VA-261	AF7981	VA-155	CAF1808P	VCA-1145	CAF7702	VCA-1166	PH51A	VO-55
AF7825	VA-97	AF7982	VA-172	CAF1809P	VCA-1134	CAF7721	VCA-1162	PH561	VO-15
AF7826	VA-416	AF7983	VA-345	CAF1810P	VCA-1103	CAF7722	VCA-1127	PH59	VO-108
AF7827	VA-158	AF7984	VA-154	CAF1811P	VCA-1172	CAF7742	VCA-1165	PH610	VO-101
AF7828	VA-83	AF7985	VA-333	CAF1812C	VCA-1074	CAF7749	VCA-1168	PH8A	VO-1
AF7831	VA-370	AF7989	VA-347	CAF1812P	VCA-1169	CAF7799	VCA-1133	PH820	VO-88
AF7832	VA-98	AF7990	VA-165	CAF1813P	VCA-1041	G16	VG-2	P1009	VO-114
AF7833	VA-99	AF7991	VA-170	CAF1814P	VCA-1035	G481	VG-14	P1014	VO-142
AF7836	VA-101	AF7992	VA-279	CAF1815P	VCA-1044	G578	VG-33	P1015	VO-153
AF7841	VA-102	AF7996	VA-169	CAF1816P	VCA-1031	G580	VG-30	P1016	VO-164
AF7842	VA-103	AF7998	VA-192	CAF1817P	VCA-1075	G6367	VG-32	P1017	VO-117
AF7843	VA-104	AF7999	VA-193	CAF1818P	VCA-1066	G800	VG-16	P1023	VO-174
AF7845	VA-105	AF8248	VA-147	CAF1820P	VCA-1047	LAF1520	VA-324	P1026	VO-167
AF7849	VA-124	AF89	VA-34	CAF1821P	VCA-1113	LAF1617	VA-93	P1028	VO-165
AF785	VA-44	AF9010	VA-163	CAF1823B	VCA-1101	LAF1646	VA-174	P1035	VO-166
AF7854	VFAP-7854	AF9098	VA-196	CAF1830P	VCA-1146	LAF1675	VA-410	P1037	VO-168
AF7857	VFAP-7857	AF917	VFAP-917	CAF1834P	VCA-1089	LAF1680	VA-122	P1051	VO-173
AF7858	VA-106	AF925	VA-85	CAF1835P	VCA-1054	LAF2886	VA-239	P1069	VO-172
AF7859	VFAP-7859	AF9546	VA-335	CAF1839P	VCA-1046	LAF2947	VA-218	P1072	VO-37
AF7861	VA-387	AF974	VA-65	CAF1845P	VCA-1069	LAF2959	VA-381	P2062	VO-115
AF7862	VA-107	AF9911	VA-429	CAF1846P	VCA-1051	LAF3141	VA-295	P2129	VO-67
AF7863	VA-108	AF9912	VA-306	CAF1848P	VCA-1038	LAF3231	VA-469	P2224	VO-73
AF7867	VA-125	AF9918	VA-430	CAF1849P	VCA-1034	LAF5980	VA-177	P2902	VO-144
AF7872	VA-109	CAF10004P	VCA-2055	CAF1850P	VCA-1049	LAF6902	VA-266	P3040	VO-77
AF7873	VA-110	CAF10009P	VCA-2051	CAF1851P	VCA-1110	LAF6927	VA-462	P3244	VO-76
AF7874	VA-89	CAF1700	VCA-1157	CAF1852P	VCA-1052	LAF8837	VA-264	P3969	VO-129
AF7875	VA-338	CAF1702	VCA-1026	CAF1855P	VCA-1144	LAF9096	VA-167	P3986	VO-85
AF7876	VA-128	CAF1703	VCA-1001	CAF1857P	VCA-1194	LFP2051	VO-104	P4456	VO-78
AF7877	VA-90	CAF1704	VCA-1021	CAF1862P	VCA-1050	LFP2286	VO-63	P8153	VO-69
AF7878	VA-111	CAF1706	VCA-1002	CAF1865P	VCA-1053	LFP2999	VO-75	P8170	LC-8170
AF7879	VA-112	CAF1707	VCA-1003	CAF1867P	VCA-1062	LFP6288	VO-170	P8198	VO-74
AF7880	VA-113	CAF1708	VCA-1167	CAF1868P	VCA-1059	LFP780	VO-64	P833	LC-833
AF7882	VA-114	CAF1713	VCA-1017	CAF1869P	VCA-1055	LFP784	VO-46	P834	LC-834
AF7883	VA-395	CAF1716	VCA-1161	CAF1872C	VCA-1078C	LP2017	VO-81	P837	VO-66
AF7884	VA-157	CAF1717	VCA-1123	CAF1872P	VCA-1078	PH10063	VO-88	P838	VO-127
AF7885	VFAP-7865	CAF1720	VCA-1060	CAF1873P	VCA-1061	PH10064	VO-200	P842	VO-97
AF7892	VFAP-7892	CAF1722	VCA-1162	CAF1874P	VCA-1116	PH10066	VO-202	P843	VO-62
AF7893	VFAP-7893	CAF1722	VCA-1127	CAF1875P	VCA-1171	PH1218	VO-56	P8445	LC-8445
AF7905	VA-131	CAF1726	VCA-1122	CAF1876P	VCA-1115	PH1500	VO-201	P845	VO-150
AF7906	VA-132	CAF1730	VCA-1039	CAF1878P	VCA-1094	PH2005	VO-118	P846	VO-150
AF7907	VA-148	CAF1739	VCA-1040	CAF1879P	VCA-1076	PH2008	VO-86	P856	VO-71
AF7908	VFAP-7908	CAF1742	VCA-1022	CAF1885P	VCA-1118	PH2009	VO-86	P907	VO-138

CAUTION: For general references only. Check catalog for correct filter application. Any use of this interchanging to determine filter application is done at the installers risk.

PRECAUCION: Solamente para referencias generales. Revise el catálogo para la correcta aplicación del filtro. Cualquier uso de la referencia cruzada para determinar la aplicación del filtro es riesgo del instalador. ATTENTION : Seulement pour les références d'ordre général. Contrôler l'application correcte du filtre avec le catalogue. Toute utilisation de moyens afin de déterminer l'application d'un filtre est faite aux risques de l'installateur.

Cross Reference

Table da equivalencias da fabricantes

Code de renvoi au fabricant

MFR'S NUMBER	REPLACEMENT NUMBER	MFR'S NUMBER	REPLACEMENT NUMBER	MFR'S NUMBER	REPLACEMENT NUMBER	MFR'S NUMBER	REPLACEMENT NUMBER	MFR'S NUMBER	REPLACEMENT NUMBER
CHAMP		P990XL	VO-110	4861737AA	VA-286	53032527AB	VA-179	83200065	VO-56
P929	VO-128	P992XL	VO-149	4861746AA	VA-293	53032700AA	VA-177	83200066	VO-19
P960	VO-80	CHRYSLER		4861746AB	VA-293	53032700AA	VA-272	DEFENSE	
P961	VO-94	J3242397	VO-58	4861756AA	VA-273	53032700AB	VA-177	DA10013	VA-202
P962	VO-112	J8132313	VO-16	4864442	VA-111	53034018AD	VA-258	DA10014	VA-200
P964	VO-82	J8134325	VO-65	4874153	VA-112	53034018AE	VA-258	DA10086	VA-208
P966	VO-92	J8134326	VO-95	4882141	VA-112	53034051AB	VA-264	DA10118	VA-229
P967	VO-84	J8134327	VO-55	4884899AB	VO-88	53034249AA	VA-272	DA10165	VA-212
P968	VO-87	J8990499	VO-1	4884899AC	VO-88	53040025	VA-132	DA10169	VA-209
P969	VO-91	J8992430	VG-2	4884900AB	VO-88	5510026AA	VA-189	DA10171	VA-214
P972	VO-90	J8992661	VA-321	4891097AA	VA-137	55111302AA	VCA-1097	DA10190	VA-231
P978	VO-111	J8993146	VO-108	4891176AA	VA-156	68013676AA	VA-349	DA10192	VA-213
P979	VO-96	MB906051	VA-104	4891691AA	VA-213	68033193AA	VCA-1093	DA10193	VA-340
P980	VO-102	MD084963	VO-19	4891694AA	VA-229	68037059AA	VA-232	DA10233	VA-242
P981	VO-98	MD308302	VO-95	4891713AA	VA-154	68042866AA	VCA-1044	DA10242	VA-224
P982	VO-99	MD352626	VO-106	4891916AA	VA-245	68042866AB	VCA-1044	DA10261	VA-264
P985	VO-103	MD353795	VO-95	4891926AA	VA-154	68071668AA	VCA-1077	DA10262	VA-223
P986	VO-141	MD360935	VO-106	4892339AA	VO-88	68073648AA	VA-310	DA10343	VA-234
P987	VO-131	MO-899	VO-88	5011836AA	VA-155	68079487AA	VCA-1073	DA10344	VA-252
P989	VO-109	T0720978	VO-35	5011844AA	VO-64	68079744AA	VO-110	DA10349	VA-233
P990	VO-110	T0730077	VO-35	5013595AA	VCA-1170	68079744AB	VO-110	DA10470	VA-235
P992	VO-149	O4713715	VA-321	5013595AB	VCA-1170	68079744AC	VO-110	DA10516	VA-245
P993	VO-116	O4892339AA	VO-88	5015171AA	VO-150	68079744AD	VO-110	DA10755	VA-273
P995	VO-132	1739547	VA-321	5015610AA	VA-342	68081249AC	VA-287	DA10881	VA-265
P996	VO-121	1851658	VO-1	5015901AA	VO-82	68082570AA	VA-473	DA10889	VA-283
P997	VO-151	2463984	VA-321	5016547AA	VO-64	68095335AA	VO-170	DA11033	VA-295
P998	VO-133	3032404AA	VA-160	5016547AC	VO-64	68096453AA	VCA-1120	DA11050	VA-286
CHAMP XL		33003509	VO-35	5016646AA	VA-321	68102241AA	VO-116	DA11113	VA-292
LFP2051XL	VO-104	33004195	VO-35	5018478AA	VO-16	68109834AA	VO-142	DA160	VA-321
LFP2999XL	VO-75	3549957	VO-95	5018637AA	VO-58	68127809AA	VCA-1044	DA192	VA-402
LFP780XL	VO-64	3685741	VO-95	5018777AA	VA-164	68157194AA	VA-428	DA326	VA-2
LP2017XL	VO-81	4105409	VO-25	5018777AB	VA-164	68164981AA	VCA-1037	DA327	VA-403
PH2808XL	VO-106	4105409AB	VO-25	5019002AA	VA-180	68169308AA	VCA-1193	DA3559	VA-40
PH2835XL	VO-25	4105409AC	VO-25	5037333AA	VO-95	68172459AA	VA-293	DA3588	VA-38
PH2835XL	VO-95	4105409BB	VO-25	5037615AA	VA-180	68190705AA	VA-460	DA3647	VA-44
PH2835XL	VO-95	4213582	VA-40	5038041AA	VO-88	68191349AA	VO-114	DA3660	VA-69
PH2840XL	VO-40	4213583	VA-69	5038070AA	VA-330	68191349AB	VO-114	DA3901	VA-90
PH2867XL	VO-106	4227087	VA-40	5047769AA	VO-152	68191349AC	VO-114	DA3902	VA-85
PH2876XL	VO-106	4241042	VA-69	5058040AA	VCA-1036	68195830AA	VA-473	DA3914	VFAP-917
PH400XL	VO-1	4243445	VO-19	5058693AA	VCA-1069	68197769AA	VO-88	DA3916	VA-65
PH400XL	VO-118	4243693	VO-19	5083285AA	VO-64	68223044AA	VCA-1176	DA4309	VA-86
PH400XL	VO-118	4243805	VO-19	5086301AA	VO-69	68229402AA	VO-142	DA4939	VA-408
PH44XL	VO-108	4306113	VA-40	5093092AA	VO-64	68233626AA	VCA-1097	DA5056	VA-205
PH44XL	VO-58	4306393	VA-321	5102905AA	VO-69	68237532AA	VO-106	DA5057	VA-413
PH47XL	VO-16	4342800	VA-69	5102905AB	VO-69	68245310AA	VA-502	DA5058	VA-66
PH47XL	VO-55	4342801	VA-40	5103554AA	VA-380	68245454AA	VA-428	DA5466	VFAP-7892
PH48XL	VO-88	4429395	VO-64	5103554AB	VA-380	68247339AA	VA-455	DA5595	VFAP-7893
PH500XL	VO-88	4429615	VO-64	5103555AA	VA-380	68257030AA	VA-499	DA6366	VA-70
PH561XL	VO-15	4494477	VO-19	5142416AA	VO-106	68257791AA	VA-258	DA6395	VA-84
PH561XL	VO-15	4573031	VA-107	5142416AB	VO-106	68267921AA	VCA-1187	DA6479	VA-78
PH59XL	VO-108	4573624	VA-112	5175567AA	VO-106	68308950AB	VCA-1195	DA6555	VA-88
PH610XL	VO-101	4591100	VA-116	5175571AA	VO-129	68318365AA	VCA-1064	DA6626	VA-269
PH820XL	VO-88	4591100AB	VA-116	5183748AA	VO-69	68320315AB	VA-503	DA6690	VA-96
P1009XL	VO-114	4591100AC	VA-116	5184231AA	VO-88	68350346AA	VCA-1187	DA6807	VA-83
P1017XL	VO-117	4593914AB	VA-290	5189933AA	VA-232	68386779AA	VA-504	DA6828	VA-416
P2062XL	VO-115	4596501AB	VCA-2033	52022378AA	VA-434	68406048AA	VCA-1064	DA6900	VA-261
P2129XL	VO-67	4596501AC	VCA-2033	52022378AB	VA-434	68410725AA	VCA-1024	DA7094	VA-101
P3244XL	VO-76	4627127AB	VA-303	5281090	VO-95	82204691	VCA-1170	DA7167	VA-98
P3986XL	VO-85	4693140AA	VO-82	5281090AA	VO-95	82205905	VCA-1168	DA7174	VA-103
P8170XL	LC-8170	4713715	VA-321	53002656	VO-35	82206886	VCA-1036	DA7344	VA-104
P960XL	VO-80	4720364	VO-118	53004383	VA-90	82208300	VCA-1170	DA7351	VA-102
P967XL	VO-84	4728406	VA-111	53004383AB	VA-90	83200000	VO-118	DA7365	VFAP-7854
P968XL	VO-87	4746914	VO-64	53007386	VA-105	83200005	VA-402	DA7414	VA-107
P969XL	VO-91	4778838	VO-118	53020311	VO-95	83200008	VA-403	DA7417	VFAP-7859
P972XL	VO-90	4781452AA	VO-118	53030688	VA-105	83200009	VA-2	DA7420	VA-113
P979XL	VO-96	4781452BA	VO-118	53030850	VCA-1093	83200012	VA-40	DA7421	VA-108
P980XL	VO-102	4781452BB	VO-118	53030850AB	VCA-1093	83200018	VA-38	DA7426	VA-106
P981XL	VO-98	4797777	VA-129	53032068AA	VA-132	83200052	VO-25	DA7431	VA-124
P982XL	VO-99	4797777AC	VA-129	53032404AA	VA-160	83200053	VA-44	DA7432	VA-112
P985XL	VO-103	4856649	VA-111	53032404AB	VA-160	83200054	VA-69	DA7440	VA-105
P985XL	VO-69	4861480AA	VA-154	53032527AA	VA-179	83200057	VA-45	DA7597	VA-109

CAUTION: For general references only. Check catalog for correct filter application. Any use of this interchange to determine filter application is done at the installers risk.
 PRECAUCION: Solamente para referencias generales. Revise el catálogo para la correcta aplicación del filtro. Cualquier uso de la referencia cruzada para determinar la aplicación del filtro es riesgo del instalador. ATTENTION : Seulement pour les références d'ordre général. Contrôler l'application correcte du filtre avec le catalogue. Toute utilisation de moyens afin de déterminer l'application d'un filtre est faite aux risques de l'installateur.

Cross Reference

Table da equivalencias da fabricantes

Code de renvoi au fabricant

MFR'S NUMBER	REPLACEMENT NUMBER	MFR'S NUMBER	REPLACEMENT NUMBER	MFR'S NUMBER	REPLACEMENT NUMBER	MFR'S NUMBER	REPLACEMENT NUMBER	MFR'S NUMBER	REPLACEMENT NUMBER
DEFENSE		DC001	VCA-1002	DL5	VO-56	143-2107	VA-408	DW24720	VA-104
DA7598	VA-110	DC002	VCA-1157	DL5343	VO-106	150-1001	VO-40	DW24722	VFAP-7892
DA7600	VA-338	DC003	VCA-1001	DL6607	VO-106	150-1003	VO-25	DW24731	VA-108
DA7614	VA-120	DC008C	VCA-1166	DL7317	VO-106	150-1006	VO-106	DW24831	VFAP-7857
DA7626	VA-125	DC031	VCA-1003	DL7328	VO-95	150-1007	VO-25	DW24858	VFAP-1612
DA7628	VFAP-7857	DC034	VCA-1008	DL8A	VO-1	150-1008	VO-106	DW24873	VA-113
DA7640	VA-111	DC035	VCA-1022	DL8081	LC-8170	150-1009	VO-106	DW24880	VA-109
DA7730	VA-89	DC036	VCA-1029	DL8158	VO-150	150-1010	VO-106	DW24881	VA-110
DA7738	VFAP-1612	DC037	VCA-1163	DL8316	VO-118	150-2008	VO-108	DW2500	VO-88
DA7764	VA-135	DC038	VCA-1020	DL8481	VO-69	150-2010	VO-15	DW25048	VA-112
DA7774	VA-114	DC039C	VCA-1165	DL8530	VO-71	150-2011	VO-101	DW25049	VFAP-7893
DA8038	VA-92	DC040	VCA-1012	DL8712	VO-66	150-2074	VO-88	DW25082	VCA-1001
DA8039	VA-94	DC041C	VCA-1164	DL8765	VO-67	150-2075	VO-88	DW25089	VA-129
DA8040	VFAP-7908	DC044	VCA-1028	DL8806	VO-73	150-3020	VO-87	DW25148	VFAP-7908
DA8069	VA-144	DC047	VCA-1030	DL8873	VO-65	150-3021	VO-84	DW252	VO-15
DA8127	VA-412	DC048	VCA-1014	DL8994	VO-93	150-3023	VO-96	DW25245	VCA-1002
DA8133	VA-117	DC049C	VCA-1168	DL9010	VO-86	150-3024	VO-102	DW25246	VCA-1021
DA8142	VFAP-1643	DC054	VCA-1013	DL9018	VO-76	150-3038	VO-85	DW25248	VA-117
DA8205	VA-129	DC057	VCA-1125	DL9024	VO-120	150-3090	VO-92	DW25249	VA-118
DA8221	VA-91	DC058	VCA-1063	DL9100	VO-75	453-1006	VCA-1013	DW25301	VA-142
DA8243	VA-260	DC060	VCA-1014	DL9461	VO-77	453-1007	VCA-1129	DW25306	VA-137
DA8475	VA-118	DC062	VCA-1067	DL9549	VO-81	453-1011	VCA-1014	DW25324	VA-140
DA8602	VA-138	DC063	VCA-1024	DL9566	VO-25	453-1013	VCA-1014	DW25353	VA-150
DA8606	VA-116	DC072	VCA-1042	DL9641	VO-80	453-1019	VCA-1031	DW25372	VA-156
DA8747	VA-156	DC085	VCA-1065	DL9688	VO-106	453-2005	VCA-1060	DW25373	VA-152
DA8754	VA-78	DC087	VCA-1068	DL9713	VO-116	453-2010	VCA-1020	DW25387	VCA-1163
DA8755A	VA-324	DC093C	VCA-1096	DL9837	VO-108	453-2020	VCA-1043	DW25395	VA-193
DA8756	VA-259	DC094	VCA-1039	DL9897	VO-52	453-6001	VCA-1110	DW25405	VA-155
DA8766	VFAP-7859	DC096C	VCA-2033	DL9911	VO-85	453-6005	VCA-1047	DW25418	VA-162
DA8805	VA-137	DL10060		DL9972	VO-84	453-6012	VCA-1062	DW25446	VA-167
DA8817	VA-164	DL10075		DL9999	VO-91	453-6016	VCA-1048	DW25456	VA-196
DA8911	VA-165	DL10158		DENSO		453-6017	VCA-1034	DW25463	VA-171
DA8918	VA-146	DL10246		115010-5021	VO-25	453-6018	VCA-1044	DW25478	VCA-1020
DA8922	VA-190	DL10295		143-2002	VFAP-7893	454-1017	VCA-1039	DW25480	VCA-1029
DA8925	VA-122	DL10358		143-2004	VA-416	454-2005	VCA-1162	DW25483	VCA-1161
DA8956	VA-142	DL10515		143-2005	VA-136	454-4007	VCA-1135	DW25490	VCA-1030
DA8969	VA-140	DL10575		143-2005	VO-88			DW25503	VA-183
DA8997	VA-149	DL10600		143-2011	VO-101		VFAP-7892	DW1A	VA-197
DA9053	VA-155	DL10855		143-2020	VO-109		VA-83	DW10131	VCA-1102
DA9054	VA-154	DL10955		143-2022	VO-110		VA-103	DW111	VA-229
DA9113	VA-150	DL11665		143-2029	VO-114		VA-118	DW13192	VA-212
DA9269	VA-169	DL16		143-2030	VO-95		VA-117	DW14650	VA-231
DA9332	VA-162	DL2		143-2031	VO-88		VA-148	DW14860	VCA-1104
DA9345	VA-161	DL25		143-2033	VO-108		VA-270	DW15363	VA-224
DA9360	VA-163	DL2825		143-2036	VO-15		VA-338	DW15388	VCA-1041
DA9361	VA-192	DL2870A		143-2044	VO-15		VA-99	DW15389	VCA-1031
DA9392	VA-193	DL2951		143-2045	VO-40		VA-387	DW15390	VCA-1034
DA9400	VA-167	DL30		143-2046	VO-65		VA-153	DW15439	VCA-1069
DA9401	VA-160	DL3387A		143-2048	VO-16		VA-128	DW15471	VCA-1044
DA9441	VA-172	DL3506		143-2049	VO-58		VA-104	DW15510	VCA-1049
DA9481	VA-270	DL3506A		143-2057	VO-58		VA-86	DW15599	VA-402
DA9482	VA-171	DL3531		143-2058	VO-27		VA-370	DW15703	VG-14
DA9492	VA-176	DL3569		143-2060	VO-15		VA-261	DW15850	VA-44
DA9493	VA-196	DL3593A		143-2060	VO-106		VFAP-7908	DW15857	VA-65
DA9525	VA-247	DL3593A		143-2065	VO-106		VA-144	DW15873	VA-78
DA9563	VA-322	DL3593A		143-2072	VO-52		VA-84	DW195	VA-99
DA9564	VA-183	DL3600		143-2073	VO-118		VA-84	DW2222	VA-98
DA9589	VA-177	DL3614		143-2075	VO-25		VA-414	DW23465	VFAP-7859
DA9600	VA-184	DL3675		143-2076	VO-108		VFAP-7892	DW23592	VA-103
DA9662	VA-189	DL3682		143-2077	VO-25		VA-125	DW241	VFAP-917
DA9683	VA-195	DL3786		143-2080	VO-63		VA-401	DW24278	VA-89
DA9687	VA-182	DL3950		143-2081	VO-19		VA-102	DW24342	VA-94
DA9762	VA-179	DL3970		143-2083	VO-37		VA-146	DW24343	VA-114
DA9778	VA-181	DL3976A		143-2084	VO-64		VA-98	DW24372	VA-125
DA9838	VA-180	DL3980		143-2085	VO-55		VA-339	DW24378	VA-135
DA9898	VA-207	DL3980A		143-2086	VO-55		VA-163	DW24468	VFAP-1643
DA9902	VA-188	DL3985		143-2090	VO-35		VA-159	DW24633	VA-260
DA9944	VA-197	DL43		143-2092	VO-95		VA-408	DW24645	VA-144
DA9948	VA-269	DL4386		143-2095	VO-40		VA-158	DW24680	VA-91
DA9969	VA-203	DL4681		143-2103	VO-15		VA-401	DW24690	VA-153
DA9997	VA-198	DL4967		143-2105	VO-40		VFAP-7859	DW24712	VA-116
							VFAP-7854	DW35265	

CAUTION: For general references only. Check catalog for correct filter application. Any use of this interchange to determine filter application is done at the installers risk.

PRECAUCION: Solamente para referencias generales. Revise el catálogo para la correcta aplicación del filtro. Cualquier uso de la referencia cruzada para determinar la aplicación del filtro es riesgo del instalador. ATTENTION : Seulement pour les références d'ordre général. Contrôler l'application correcte du filtre avec le catalogue. Toute utilisation de moyens afin de déterminer l'application d'un filtre est faite aux risques de l'installateur.

Cross Reference

Table da equivalencias da fabricantes

Code de renvoi au fabricant

MFR'S NUMBER	REPLACEMENT NUMBER	MFR'S NUMBER	REPLACEMENT NUMBER	MFR'S NUMBER	REPLACEMENT NUMBER	MFR'S NUMBER	REPLACEMENT NUMBER	MFR'S NUMBER	REPLACEMENT NUMBER
DRIVEWORKS		DW4631	VO-56	DA1612	VFAP-1612	DA3895	VA-194	DA4042	VA-236
DW35267	VA-138	DW4631	VO-56	DA1613	VFAP-1613	DA3896	VA-274	DA4044	VA-221
DW35290	VA-114	DW4651	VO-88	DA1615	VA-94	DA3897	VA-318	DA4045	VA-220
DW35305	VA-146	DW4666	VO-15	DA1618	VA-120	DA3898	VA-329	DA4048	VA-245
DW35323	VA-149	DW4670	VO-95	DA1624	VA-181	DA3899	VA-368	DA4049	VA-375
DW35330	VA-78	DW47039	VA-157	DA1630	VA-404	DA3904	VA-180	DA4051	VA-294
DW35396	VA-154	DW4757	VO-62	DA1641	VFAP-1641	DA3905	VA-199	DA4052	VA-383
DW35397	VA-165	DW4872	VO-63	DA1643	VFAP-1643	DA3906	VA-355	DA4054	VA-384
DW35402	VCA-1122	DW50091	VA-2	DA1646	VA-174	DA3908	VA-367	DA4055	VA-250
DW35403	VA-192	DW50092	VA-403	DA1679	VA-142	DA3910	VA-317	DA4057	VA-358
DW35414	VA-164	DW5230	VO-118	DA1680	VA-122	DA3927	VA-443	DA4058	VA-385
DW35426	VCA-1024	DW5247	LC-8170	DA1688	VA-140	DA3933	VA-204	DA4062	VA-268
DW35431	VA-176	DW5274	VO-67	DA1695	VA-162	DA3935	VA-323	DA4063	VA-366
DW35432	VA-163	DW5276	VO-69	DA1696	VA-149	DA3936	VA-365	DA4064	VA-378
DW35433	VA-161	DW5280	VO-74	DA1744	VA-322	DA3938	VA-309	DA4065	VA-257
DW35448	VCA-1022	DW5288	VO-108	DA1754	VA-182	DA3954	VA-187	DA4067	VA-275
DW35462	VA-160	DW5308	VO-71	DA178	VA-402	DA3955	VA-205	DA4897	VA-253
DW35479	VCA-1014	DW5309	VO-73	DA1890	VA-241	DA3956	VA-179	DA4904	VA-284
DW35484	VCA-1124	DW5313	VO-65	DA2014	VA-161	DA3957	VA-328	DA5185	VA-265
DW35491	VCA-1028	DW5313	VO-65	DA2340	VA-175	DA3958	VA-206	DA5187	VA-283
DW35494	VCA-1168	DW5315	VO-66	DA2441	VA-247	DA3959	VA-195	DA5190	VA-273
DW35509	VCA-1127	DW5335	VO-64	DA2442	VA-352	DA3960	VA-359	DA5191	VA-189
DW35516	VCA-1014	DW5399	VO-75	DA2548	VA-342	DA3961	VA-330	DA5196	VA-291
DW35519	VCA-1063	DW5401	VO-93	DA2771	VA-197	DA3963	VA-386	DA5197	VA-293
DW35528	VA-182	DW5436	VO-76	DA2780	VA-222	DA3965	VA-337	DA5199	VA-310
DW35530	VCA-1068	DW54669	VA-97	DA2782	VA-382	DA3974	VA-207	DA520	VA-473
DW35534	VA-206	DW54714	VG-33	DA2785	VA-215	DA3975	VA-188	DA5206	VA-300
DW35556	VA-181	DW5505	VO-80	DA2786	VA-216	DA3981	VA-340	DA5207	VA-301
DW35560	VA-180	DW5521	VO-85	DA2883	VA-223	DA3982	VA-314	DA5208	VA-297
DW35578	VA-195	DW5526	VO-81	DA2884	VA-224	DA3983	VA-251	DA5210	VA-307
DW35592	VA-198	DW55378	VA-111	DA2893	VA-246	DA3984	VA-198	DA5216	VA-344
DW35603	VA-200	DW55400	VA-169	DA293	VA-86	DA3991	VA-379	DA5217	VA-331
DW35643	VCA-1070	DW5581	VO-85	DA2944	VA-306	DA3992	VA-202	DA5220	VA-312
DW35644	VCA-1037	DW5607	VO-91	DA2956	VA-203	DA3993	VA-208	DA5221	VA-427
DW35649	VA-214	DW5608	VO-84	DA2962	VA-200	DA3994	VA-248	DA5222	VA-304
DW35661	VCA-1035	DW5609	VO-87	DA3054	VA-217	DA3996	VA-209	DA5223	VA-305
DW35667	VCA-1031	DW5610	VO-90	DA3076	VA-360	DA3997	VA-356	DA5224	VA-311
DW35672	VA-154	DW5702	VO-96	DA3083	VA-225	DA3998	VA-289	DA5230	VA-419
DW35675	VCA-1139	DW6311	VO-102	DA3095	VA-219	DA3999	VA-226	DA5233	VA-434
DW35676	VCA-1065	DW63181	VA-45	DA3096	VA-263	DA4	VA-321	DA5240	VA-440
DW35677	VCA-2033	DW64711	VG-32	DA3128	VA-254	DA4000	VA-227	DA5781	VA-390
DW35707	VA-203	DW65455	VG-16	DA3139A	VA-296	DA4001	VA-228	DA6151	VA-287
DW36309	VA-221	DURALAST		DA3139B	VA-296	DA4002	VA-210	DA6168	VA-290
DW38188	VCA-1042	FF2202DL	VG-2	DA3141	VA-295	DA4003	VA-201	DA6171	VA-292
DW38222	VCA-1067	FF3504DL	VG-14	DA3145	VA-285	DA4004	VA-353	DA6201	VA-299
DW40004	VA-321	FF4508DL	VG-33	DA3148	VA-327	DA4006	VA-362	DA6273	VA-426
DW4006	VO-58	FF609DL	VG-30	DA3173	VA-280	DA4007	VA-211	DA6280	VA-302
DW4011	VO-55	FF679DL	VG-16	DA3174	VA-308	DA4008	VA-212	DA6900	VA-267
DW43195	VA-38	FF745DL	VG-32	DA3178	VA-457	DA4009	VA-374	DA6902	VA-266
DW4457	VO-25	DURAMAX		DA3195	VA-425	DA4010	VA-282	DA6908	VA-288
DW4459	VO-106	DA1031	VA-69	DA3216	VA-183	DA4011	VA-213	DA6910	VA-298
DW4460	VO-106	DA1032A	VA-205	DA3217	VA-373	DA4012	VA-229	DA697	VA-45
DW4466	VO-15	DA10418	VA-437	DA3219	VA-316	DA4014	VA-230	DA773	VA-38
DW44688	VA-207	DA1042	VA-413	DA3220	VA-447	DA4015	VA-231	DA7816	VA-96
DW44727	VA-105	DA10423	VA-438	DA3245	VA-184	DA4017	VA-214	DA7823	VA-261
DW4476	VO-40	DA1043	VA-66	DA329	VA-403	DA4019	VA-242	DA7825	VA-97
DW4484	VO-60	DA1046	VA-70	DA348	VA-2	DA4020	VA-343	DA7826	VA-416
DW45090	VA-92	DA10460	VA-418	DA351	VA-84	DA4021	VA-240	DA7827	VA-158
DW45105	VFAP-7865	DA10469	VA-453	DA3588	VA-164	DA4022	VA-243	DA7828	VA-83
DW45314	VA-259	DA10483	VA-466	DA3589	VA-185	DA4023	VA-244	DA7831	VA-370
DW45383	VCA-1026	DA10492	VA-455	DA359	VA-408	DA4025	VA-258	DA7832	VA-98
DW45384	VCA-1017	DA10496	VA-454	DA3590	VA-160	DA4026	VA-232	DA7833	VA-99
DW45459	VCA-1013	DA1061	VA-88	DA3591	VA-363	DA4027	VA-252	DA7836	VA-101
DW45508	VCA-1040	DA1096	VA-78	DA3592	VA-237	DA4028	VA-357	DA7841	VA-102
DW45512	VA-177	DA1129	VA-269	DA3593	VA-325	DA4029	VA-238	DA7842	VA-103
DW45650	VA-209	DA1236	VA-412	DA3594	VA-176	DA4030	VA-233	DA7843	VA-104
DW45654	VCA-1043	DA1279	VA-91	DA3595	VA-171	DA4031	VA-234	DA7845	VA-105
DW45662	VCA-1066	DA1300	VA-92	DA3598	VA-186	DA4033	VA-235	DA7849	VA-124
DW45871	VCA-1038	DA1301	VA-320	DA3601	VA-249	DA4034	VA-278	DA785	VA-44
DW4612	VO-106	DA1519	VA-259	DA372	VA-414	DA4035	VA-372	DA7857	VFAP-7857
DW4619	VO-35	DA1520	VA-324	DA388	VA-411	DA4038	VA-332	DA7858	VA-106

CAUTION: For general references only. Check catalog for correct filter application. Any use of this interchange to determine filter application is done at the installers risk.
 PRECAUCION: Solamente para referencias generales. Revise el catálogo para la correcta aplicación del filtro. Cualquier uso de la referencia cruzada para determinar la aplicación del filtro es riesgo del instalador. ATTENTION : Seulement pour les références d'ordre général. Contrôler l'application correcte du filtre avec le catalogue. Toute utilisation de moyens afin de déterminer l'application d'un filtre est faite aux risques de l'installateur.

Cross Reference

Table da equivalencias da fabricantes

Code de renvoi au fabricant

MFR'S NUMBER	REPLACEMENT NUMBER	MFR'S NUMBER	REPLACEMENT NUMBER	MFR'S NUMBER	REPLACEMENT NUMBER	MFR'S NUMBER	REPLACEMENT NUMBER	MFR'S NUMBER	REPLACEMENT NUMBER
DURAMAX		DC1872C	VCA-1078C	DO784	VO-46	XA10418	VA-437	XA4715	VA-99
DA7861	VA-387	DC1875P	VCA-1171	DO8A	VO-1	XA10421	VA-430	XA4717	VA-98
DA7862	VA-107	DC1885P	VCA-1118	DO8153	VO-69	XA10423	VA-438	XA4720	VA-104
DA7863	VA-108	DC1897C	VCA-1080	DO8154	VO-115	XA10424	VA-432	XA4721	VFAP-7859
DA7864	VFAP-7859	DC1898P	VCA-1077	DO8170	LC-8170	XA10426	VA-417	XA4722	VFAP-7892
DA7867	VA-125	DC1899P	VCA-1177	DO8198	VO-74	XA10460	VA-418	XA4727	VA-105
DA7872	VA-109	DC1900P	VCA-1081	DO820	VO-88	XA10464	VA-449	XA4729	VA-379
DA7873	VA-110	DC1904C	VCA-1183	DO833	LC-833	XA10467	VA-431	XA4731	VA-108
DA7874	VA-89	DC1904P	VCA-1184	DO834	LC-834	XA10469	VA-453	XA4799	VA-103
DA7875	VA-338	DC1908P	VCA-1174	DO837	VO-66	XA10481	VA-334	XA4807	VA-370
DA7876	VA-128	DC1911P	VCA-1097	DO838	VO-127	XA10483	VA-466	XA4819	VA-107
DA7877	VA-90	DC1914P	VCA-1173	DO842	VO-97	XA10486	VA-456	XA4831	VFAP-7857
DA7878	VA-111	DC36179	VCA-1075	DO843	VO-62	XA10492	VA-455	XA4832	VA-106
DA7879	VA-112	DC6154	VCA-1078	DO8445	LC-8445	XA10496	VA-454	XA4838	VA-132
DA7880	VA-113	DC6156	VCA-1073	DO845	VO-70	XA10498	VA-464	XA4839	VA-387
DA7882	VA-114	DC6185	VCA-1120	DO846	VO-150	XA10499	VA-459	XA4848	VFAP-7859
DA7883	VA-395	DC7702	VCA-1166	DO856	VO-71	XA10578	VA-465	XA4852	VFAP-917
DA7884	VA-157	DC7749	VCA-1168	DO929	VO-128	XA10579	VA-463	XA4855	VA-338
DA7885	VFAP-7865	DC7757	VCA-1164	DO960	VO-80	XA10580	VA-462	XA4858	VFAP-1612
DA7892	VFAP-7892	DF481	VG-14	DO961	VO-94	XA10583	VA-461	XA4859	VFAP-1613
DA7893	VFAP-7893	DF580	VG-30	DO962	VO-112	XA10586	VA-500	XA4862	VFAP-7912
DA7907	VA-148	DF800	VG-16	DO964	VO-82	XA10599	VA-470	XA4873	VA-113
DA7908	VFAP-7908	DO1009	VO-114	DO966	VO-92	XA10645	VA-474	XA4877	VA-89
DA7910	VA-129	DO1017	VO-117	DO967	VO-84	XA10648	VA-468	XA4878	VA-94
DA7911	VA-144	DO1035	VO-166	DO968	VO-87	XA10651	VA-467	XA4879	VA-114
DA7912	VFAP-7912	DO10432	VO-170	DO969	VO-91	XA10653	VA-471	XA4880	VA-109
DA7913	VA-135	DO10592	VO-173	DO972	VO-90	XA10660	VA-469	XA4881	VA-110
DA7914	VA-153	DO1218	VO-56	DO978	VO-111	XA10664	VA-132	XA4883	VA-412
DA7917	VA-116	DO2008	VO-86	DO979	VO-96	XA11536	VA-498	XA4886	VA-125
DA7920	VA-118	DO2017	VO-81	DO980	VO-102	XA11539	VA-273	XA4995	VA-124
DA7935	VA-138	DO2051	VO-104	DO981	VO-98	XA11569	VA-497	XA5042	VA-93
DA7959	VA-152	DO2129	VO-67	DO982	VO-99	XA11581	VA-501	XA5043	VA-120
DA7981	VA-155	DO2224	VO-73	DO983	VO-140	XA3181	VA-45	XA5047	VA-111
DA7982	VA-172	DO2286	VO-63	DO985	VO-103	XA3192	VA-40	XA5048	VA-112
DA7983	VA-345	DO253	VO-95	DO986	VO-141	XA3195	VA-38	XA5049	VFAP-7893
DA7990	VA-165	DO2801	VO-35	DO987	VO-131	XA3380	VA-44	XA5050	VA-128
DA7991	VA-170	DO2808	VO-106	DO989	VO-109	XA3462	VA-460	XA5089	VA-129
DA7992	VA-279	DO2815	VO-15	DO990	VO-110	XA3465	VA-69	XA5090	VA-92
DA7996	VA-169	DO2817	VO-27	DO992	VO-149	XA3474	VA-65	XA5091	VA-320
DA7998	VA-192	DO2827	VO-25	DO993	VO-116	XA3546	VA-321	XA5105	VFAP-7865
DA7999	VA-193	DO2835	VO-25	DO995	VO-132	XA3558	VA-389	XA5148	VFAP-7908
DA8164	VA-428	DO2840	VO-40	DO998	VO-133	XA3590	VA-65	XA5150	VA-135
DA8248	VA-147	DO2856A	VO-19	ECOGARD		XA3592	VA-66	XA5155	VFAP-1643
DA8837	VA-264	DO2867	VO-106	XA10003	VA-312	XA3593	VA-413	XA5192	VA-260
DA925	VA-85	DO2869	VO-106	XA10004	VA-393	XA4	VA-321	XA5206	VA-148
DA974	VA-65	DO2873	VO-123	XA10005	VA-304	XA4278	VA-86	XA5207	VA-131
DA9911	VA-429	DO2876	VO-106	XA10006	VA-305	XA4342	VA-85	XA5219	VA-144
DA9912	VA-306	DO2902	VO-144	XA10007	VA-311	XA4343	VA-205	XA5227	VA-99
DA9916	VA-451	DO2903	VO-52	XA10014	VA-344	XA4343	VA-205	XA5244	VA-153
DC10305	VCA-1176	DO2904	VO-95	XA10015	VA-308	XA4361	VA-408	XA5248	VA-117
DC10491	VCA-1185	DO2999	VO-75	XA10017	VA-303	XA4372	VA-90	XA5249	VA-118
DC1700	VCA-1157	DO3244	VO-76	XA10019	VA-307	XA4378	VA-70	XA5257	VA-136
DC1702	VCA-1026	DO3969	VO-129	XA10025	VA-301	XA4468	VA-84	XA5258	VA-178
DC1703	VCA-1001	DO3986	VO-85	XA10178	VA-446	XA44690	VA-336	XA5265	VA-116
DC1704	VCA-1021	DO400	VO-118	XA10181	VA-308	XA4479	VA-78	XA5266	VA-147
DC1707	VCA-1003	DO44	VO-58	XA10187	VA-427	XA4601	VA-414	XA5267	VA-138
DC1708	VCA-1167	DO4456	VO-78	XA10188	VA-457	XA4622	VA-274	XA5272	VA-410
DC1742	VCA-1022	DO453	VO-93	XA10190	VA-450	XA4632	VA-88	XA5278	VA-159
DC1751	VCA-1042	DO454	VO-65	XA10215	VA-424	XA4633	VA-269	XA5279	VA-339
DC1754	VCA-1029	DO47	VO-16	XA10222	VA-419	XA4645	VA-401	XA5291	VA-122
DC1755	VCA-1020	DO477	VO-122	XA10223	VA-91	XA4645	VA-96	XA5301	VA-142
DC1756	VCA-1163	DO479	VO-106	XA10226	VA-490	XA4646	VA-158	XA5304	VA-397
DC1758	VCA-1012	DO479	VO-148	XA10240	VA-392	XA4648	VA-416	XA5305	VA-146
DC1781	VCA-1063	DO48	VO-88	XA10241	VA-331	XA4650	VA-101	XA5306	VA-137
DC1800	VCA-1135	DO500	VO-88	XA10242	VA-440	XA4669	VA-97	XA5314	VA-259
DC1801P	VCA-1139	DO51A	VO-55	XA10252	VA-444	XA4675	VA-261	XA5315	VA-271
DC1808P	VCA-1145	DO561	VO-15	XA10304	VA-434	XA4680	VA-83	XA5315	VA-324
DC1812C	VCA-1074	DO59	VO-108	XA10325	VA-435	XA4688	VA-207	XA5323	VA-149
DC1815P	VCA-1044	DO610	VO-101	XA10392	VA-451	XA4690	VA-102	XA5324	VA-140
DC1845P	VCA-1069	DO6160	VO-121	XA10394	VA-428	XA4711	VA-340	XA5330	VA-78
DC1850P	VCA-1049	DO780	VO-64	XA10411	VA-425	XA4712	VFAP-7854	XA5352	VA-270

CAUTION: For general references only. Check catalog for correct filter application. Any use of this interchange to determine filter application is done at the installers risk.

PRECAUCION: Solamente para referencias generales. Revise el catálogo para la correcta aplicación del filtro. Cualquier uso de la referencia cruzada para determinar la aplicación del filtro es riesgo del instalador. ATTENTION : Seulement pour les références d'ordre général. Contrôler l'application correcte du filtre avec le catalogue. Toute utilisation de moyens afin de déterminer l'application d'un filtre est faite aux risques de l'installateur.

Cross Reference

Table da equivalencias da fabricantes

Code de renvoi au fabricant

MFR'S NUMBER	REPLACEMENT NUMBER	MFR'S NUMBER	REPLACEMENT NUMBER	MFR'S NUMBER	REPLACEMENT NUMBER	MFR'S NUMBER	REPLACEMENT NUMBER	MFR'S NUMBER	REPLACEMENT NUMBER
ECOGARD		XA5578	VA-195	XA5820	VA-236	XA7492	VA-314	XC25863	VCA-1110
XA5353	VA-150	XA5582	VA-215	XA5822	VA-219	XA7765	VA-341	XC25864	VCA-1034
XA5359	VA-151	XA5583	VA-216	XA5823	VA-349	XA91	VA-2	XC25870	VCA-1044
XA5363	VA-191	XA5584	VA-208	XA5824	VA-332	XA92	VA-403	XC25874	VCA-1113
XA5370	VA-190	XA5585	VA-184	XA5825	VA-447	XC10008	VCA-1097	XC25875	VCA-1114
XA5372	VA-156	XA5587	VA-377	XA5826	VA-318	XC10011	VCA-1174	XC25876	VCA-1049
XA5373	VA-152	XA5588	VA-188	XA5833	VA-240	XC10020	VCA-1082	XC25877	VCA-1052
XA5374	VA-90	XA5589	VA-359	XA5841	VA-246	XC10022C	VCA-1183	XC25878	VCA-1054
XA5375	VA-350	XA5592	VA-198	XA5880	VA-263	XC10189	VCA-1175	XC26073	VCA-1057
XA5378	VA-111	XA5594	VA-269	XA5883	VA-354	XC10191	VCA-1184	XC26086	VCA-1115
XA5380	VA-394	XA5595	VA-187	XA5891	VA-375	XC10257	VCA-1193	XC26087	VCA-1116
XA5381	VA-347	XA5596	VA-226	XA5907	VA-253	XC10303	VCA-1171	XC26089	VCA-1117
XA5387	VA-172	XA5601	VA-228	XA6052	VA-250	XC10305	VCA-1176	XC26155	VCA-1118
XA5393	VA-399	XA5602	VA-227	XA6054	VA-384	XC10317	VCA-1147	XC26175	VCA-1177
XA5394	VA-345	XA5603	VA-200	XA6055	VA-383	XC10386	VCA-1173	XC26176	VCA-1077
XA5395	VA-193	XA5604	VA-217	XA6056	VA-358	XC10391	VCA-1179	XC26185	VCA-1120
XA5396	VA-245	XA5620	VA-337	XA6061	VA-294	XC10434	VCA-1178	XC26205C	VCA-1080
XA5397	VA-165	XA5625	VA-248	XA6067	VFA-1641	XC10462	VCA-1189	XC35402	VCA-1122
XA5398	VA-170	XA5626	VA-365	XA6093	VA-313	XC10475	VCA-2043	XC35425	VCA-1060
XA5400	VA-169	XA5633	VA-222	XA6094	VA-268	XC10482	VCA-1181	XC35426	VCA-1024
XA5403	VA-192	XA5634	VA-213	XA6100	VA-366	XC10489	VCA-1188	XC35448	VCA-1022
XA5405	VA-155	XA5635	VA-229	XA6101	VA-385	XC10490	VCA-1190	XC35448C	VCA-1165
XA5414	VA-164	XA5638	VA-218	XA6102	VA-280	XC10491	VCA-1185	XC35479	VCA-1014
XA5418	VA-162	XA5642	VA-223	XA6103	VA-445	XC10573	VCA-1191	XC35484C	VCA-1124
XA5420	VA-166	XA5645	VA-352	XA6104	VA-378	XC10581C	VCA-1195	XC35491	VCA-1028
XA5421	VA-346	XA5647	VA-201	XA6105	VA-378	XC10590	VCA-1186	XC35494C	VCA-1168
XA5431	VA-176	XA5649	VA-214	XA6109	VA-266	XC10619C	VCA-1187	XC35498	VCA-1125
XA5432	VA-163	XA5650	VA-209	XA6114	VA-257	XC10622	VCA-2035	XC35504C	VCA-1126
XA5433	VA-161	XA5651	VA-202	XA6116	VA-273	XC11547	VCA-2055	XC35509C	VCA-1127
XA5434	VA-185	XA5652	VA-343	XA6118	VA-283	XC14860	VCA-1157	XC35516	VCA-1014
XA5440	VA-333	XA5653	VA-212	XA6119	VA-275	XC15388	VCA-1003	XC35519	VCA-1063
XA5442	VFAP-7865	XA5655	VA-231	XA6120	VA-267	XC15389	VCA-1008	XC35526C	VCA-1131
XA5443	VA-400	XA5656	VA-210	XA6124	VA-265	XC15390	VCA-1167	XC35530	VCA-1068
XA5446	VA-167	XA5657	VA-242	XA6130	VA-254	XC15439	VCA-1012	XC35576	VCA-1134
XA5449	VA-279	XA5669	VA-244	XA6131	VA-255	XC15471C	VCA-1164	XC35586	VCA-1135
XA5451	VA-361	XA5670	VA-232	XA6139	VA-391	XC15506	VCA-1160	XC35643	VCA-1070
XA5456	VA-196	XA5671	VA-243	XA6140	VA-284	XC15510C	VCA-1162	XC35644	VCA-1037
XA5457	VA-325	XA5672	VA-154	XA6143	VA-443	XC15537	VCA-1056	XC35660	VCA-1051
XA5461	VA-199	XA5673	VA-230	XA6144	VA-319	XC15599	VCA-1170	XC35661	VCA-1035
XA5462	VA-160	XA5696	VA-381	XA6145	VA-296	XC15659	VCA-1089	XC35668	VCA-1022
XA5463	VA-171	XA5697	VA-239	XA6146	VA-295	XC15850	VCA-1048	XC35674	VCA-1138
XA5467	VA-363	XA5698	VA-251	XA6149	VA-288	XC15857	VCA-1036	XC35675	VCA-1139
XA5488	VA-342	XA5699	VA-224	XA6151	VA-287	XC15862	VCA-1053	XC35675C	VCA-1139
XA5489	VA-322	XA5700	VA-356	XA6152	VA-296	XC15868	VCA-1159	XC35676	VCA-1065
XA5497	VA-335	XA5701	VA-238	XA6153	VA-291	XC15873	VCA-1046	XC35677C	VCA-2033
XA5499	VA-270	XA5703	VA-233	XA6163	VA-285	XC16079	VCA-1093	XC35845	VCA-1194
XA5503	VA-183	XA5704	VA-367	XA6165	VA-286	XC16098	VCA-1094	XC35856	VCA-1050
XA5507	VA-184	XA5707	VA-203	XA6167	VA-293	XC16108	VCA-1039	XC35860	VCA-1155
XA5512	VA-177	XA5716	VA-373	XA6168	VA-290	XC16112C	VCA-1096	XC35861	VCA-1144
XA5513	VA-175	XA5775	VA-241	XA6169	VA-327	XC16203	VCA-1098	XC35865	VCA-1047
XA5517	VA-247	XA5779	VA-235	XA6171	VA-292	XC25082	VCA-1001	XC35872	VCA-1145
XA5521	VA-189	XA5780	VA-252	XA6183	VA-310	XC25245	VCA-1002	XC35898	VCA-1146
XA5525	VA-194	XA5781	VA-390	XA6184	VA-473	XC25246	VCA-1021	XC36067	VCA-1062
XA5528	VA-182	XA5783	VA-211	XA6197	VA-297	XC25387	VCA-1163	XC36080	VCA-1061
XA5534	VA-206	XA5785	VA-329	XA6199	VA-298	XC25478	VCA-1020	XC36099	VCA-1059
XA5535	VA-174	XA5786	VA-309	XA6200	VA-300	XC25480	VCA-1029	XC36115	VCA-1055
XA5538	VA-328	XA5787	VA-351	XA6201	VA-299	XC25483	VCA-1161	XC36154	VCA-1078
XA5539	VA-380	XA5788	VA-315	XA6271	VA-429	XC25490	VCA-1030	XC36154C	VCA-1078C
XA5540	VA-370	XA5789	VA-278	XA6272	VA-306	XC25571	VCA-1101	XC36156	VCA-1073
XA5546	VA-204	XA5792	VA-282	XA6273	VA-426	XC25572	VCA-1102	XC36157	VCA-1072
XA5553	VA-179	XA5793	VA-362	XA6280	VA-302	XC25624C	VCA-1103	XC36158	VCA-1071
XA5553A	VA-179	XA5794	VA-360	XA6306	VA-237	XC25685	VCA-1104	XC36174	VCA-1081
XA5554	VA-355	XA5796	VA-323	XA6308	VA-220	XC25764	VCA-1041	XC36179	VCA-1075
XA5555	VA-386	XA5798	VA-289	XA6309	VA-221	XC25770C	VCA-1058	XC38188	VCA-1042
XA5556	VA-181	XA5799	VA-234	XA6310	VA-184	XC25832	VCA-1106	XC38222	VCA-1067
XA5557	VA-330	XA5801	VA-374	XA6312	VA-357	XC25836	VCA-1075	XC45383	VCA-1026
XA5560	VA-180	XA5802	VA-368	XA6313	VA-225	XC25840	VCA-1158	XC45383C	VCA-1166
XA5566	VA-197	XA5804	VA-353	XA6314	VA-264	XC25851	VCA-1031	XC45384	VCA-1017
XA5567	VA-249	XA5814	VA-317	XA6318	VA-316	XC25853	VCA-1109	XC45459	VCA-1013
XA5568	VA-186	XA5816	VA-372	XA67	VA-402	XC25858	VCA-1064	XC45508	VCA-1040
XA5569	VA-382	XA5819	VA-258	XA7039	VA-157	XC25859	VCA-1068	XC45527C	VCA-1074

CAUTION: For general references only. Check catalog for correct filter application. Any use of this interchange to determine filter application is done at the installers risk.

PRECAUCION: Solamente para referencias generales. Revise el catálogo para la correcta aplicación del filtro. Cualquier uso de la referencia cruzada para determinar la aplicación del filtro es riesgo del instalador. ATTENTION : Seulement pour les références d'ordre général. Contrôler l'application correcte du filtre avec le catalogue. Toute utilisation de moyens afin de déterminer l'application d'un filtre est faite aux risques de l'installateur.

Cross Reference

Table da equivalencias da fabricantes

Code de renvoi au fabricant

MFR'S NUMBER	REPLACEMENT NUMBER	MFR'S NUMBER	REPLACEMENT NUMBER	MFR'S NUMBER	REPLACEMENT NUMBER	MFR'S NUMBER	REPLACEMENT NUMBER	MFR'S NUMBER	REPLACEMENT NUMBER
ECOGARD		X4670	VO-95	S195	VO-118	F4812C	VCA-1165	G7210	VO-71
XC45621	VCA-1172	X4756	VO-70	S2222	VO-88	F4815	VCA-1063	G7211	VO-127
XC45654	VCA-1043	X4757	VO-62	S241	VO-25	F4817	VCA-1012	G7260	VO-121
XC45662	VCA-1066	X4758	LC-833	S2500	VO-88	F4818	VCA-1040	G7262	VO-132
XC45844C	VCA-1153	X4798	VO-144	S252	VO-15	F4829	VCA-1052	G7279	VO-141
XC45871	VCA-1038	X4872	VO-63	S4006	VO-58	F4854	VCA-1048	G7303	VO-82
XC46126	VCA-1076	X49	VO-65	S4011	VO-55	F4857	VCA-1068	G7311	VO-81
XF10131	VG-2	X5230	VO-118	S4459	VO-106	F4864	VCA-1168	G7312	VO-81
XF3097	VG-16	X5234	VO-85	S4476	VO-40	F4869	VCA-1043	G7327	VO-91
XF33144	VG-14	X5247	LC-8170	S4477	VO-40	F4871	VCA-1037	G7328	VO-137
XF3481	VG-14	X5251	LC-8445	S4610	VO-106	F4872	VCA-1030	G7329	VO-94
XF54714	VG-33	X5274	VO-67	S4612	VO-106	F4873	VCA-1028	G7330	VO-138
XF63169	VG-16	X5276	VO-69	S4651	VO-88	F4875	VCA-1145	G7341	VO-116
XF64702	VG-30	X5277	VO-103	S4670	VO-95	F4877	VCA-1122	G7462	VO-133
XF64711	VG-32	X5280	VO-74	S4872	VO-63	F4882	VCA-1065	G7512	VO-111
X1A	VO-1	X5288	VO-108	S5247	LC-8170	F4883	VCA-1014	G7526	VO-110
X10001	VO-149	X5308	VO-71	S5274	VO-67	F4893	VCA-1129	G7560	VO-140
X10002	VO-131	X5309	VO-73	S5288	VO-108	F4897	VCA-1013	G7674	VO-98
X10023	VO-133	X5313	VO-65	S5313	VO-65	F4900	VCA-1042	G7806	VO-97
X10040	VO-114	X5315	VO-66	S5315	VO-66	F4901	VCA-1067	PCJ5Z9601A	VA-298
X10185	VO-25	X5316	VO-127	S5335	VO-64	F4905C	VCA-1133	PDG9Z9601A	VA-429
X10231	VO-132	X5317	VO-86	S5399	VO-75	F4909C	VCA-2033	PDS7Z9601A	VA-306
X10232	VO-142	X5317	VO-86	S5505	VO-80	F6303	VCA-1162	PWA10006	VA-473
X10233	VO-153	X5335	VO-64	S5526	VO-81	F9093	VCA-1093	PWA10022	VA-392
X10239	VO-141	X5399	VO-75	S5581	VO-85	F9352	VCA-1034	PWA10058	VA-437
X10249	VO-161	X5401	VO-93	S5608	VO-84	F9353	VCA-1050	PWA10270	VA-428
X10259	VO-164	X5436	VO-76	S5848	VO-99	F9366	VCA-1142	P2013	VA-182
X10260	VO-117	X5438	VO-119	S6135	VO-110	F9371	VCA-1103	P2015	VA-147
X10306	VO-151	X5465	VO-82	S6311	VO-102	F9377	VCA-1051	P2020	VA-321
X10335	VO-124	X5476	VO-78	FACTORY MOTOR PARTS		F9466	VCA-1104	P2023	VA-361
X10383	VO-166	X5505	VO-80	F0009	VCA-1082	G0010	VO-114	P20857930	VA-457
X10387	VO-115	X5511	VO-128	F0048	VCA-1174	G0021	VO-153	P2086	VA-185
X10390	VO-174	X5526	VO-81	F0074C	VCA-1080	G0024	VO-117	P2088	VA-402
X10430	VO-167	X5536	VO-69	F0129	VCA-1173	G1145	VO-62	P2096	VA-45
X10432	VO-170	X5545	VO-150	F0142	VCA-1176	G1160	LC-834	P20972654	VA-308
X10435	VO-117	X5564	VO-112	F4012	VCA-1171	G1185	LC-833	P2098	VA-2
X10436	VO-168	X5579	VO-94	F4013	VCA-1075	G1186	VO-74	P2101	VA-403
X10479	VO-106	X5581	VO-85	F4015	VCA-1072	G1212	VO-150	P2133	VA-69
X10504	VO-172	X5593	VO-137	F4017	VCA-1073	G1213	LC-8445	P2164	VA-247
X10568	VO-169	X5598	VO-92	F4020	VCA-1038	G1223	LC-8170	P2177	VFAP-7912
X10592	VO-173	X5607	VO-91	F4030	VCA-1055	G1226	VO-69	P2188	VA-196
X111	VO-16	X5608	VO-84	F4048	VCA-1077	G1227	VO-119	P2190	VA-342
X11574	VO-175	X5609	VO-87	F4065	VCA-1049	G1246	VO-70	P2214	VA-395
X18	VO-95	X5610	VO-90	F4068	VCA-1118	G1630	VO-37	P2295	VA-157
X193	VO-19	X5646	VO-129	F4080	VCA-1071	G2711800309	VO-151	P2306	VA-399
X195	VO-118	X5690	VO-130	F4103	VCA-1175	G68109834AA	VO-142	P2329	VA-164
X2222	VO-88	X5692	VO-97	F4161	VCA-1164	G7021	VO-66	P2333	VA-408
X241	VO-25	X5702	VO-96	F4191C	VCA-1078C	G7029	VO-99	P2341	VA-142
X2500	VO-88	X5830	VO-111	F4201	VCA-1061	G7033	VO-73	P2351	VA-380
X252	VO-15	X5839	VO-98	F4313	VCA-1069	G7038	VO-69	P2384	VA-137
X257	VO-15	X5843	VO-138	F4322	VCA-1026	G7041	VO-96	P2389	VA-154
X2821	VO-40	X5848	VO-99	F4367	VCA-1059	G7047	VO-84	P2412	VA-333
X288	VO-46	X5909	VO-140	F4419	VCA-1081	G7050	VO-109	P2461	VA-394
X291	VO-27	X6127	VO-109	F4479	VCA-1044	G7059	VO-149	P2468	VA-371
X33	VO-108	X6128	VO-104	F4482	VCA-1046	G7061	VO-90	P2472	VA-138
X35895	VO-101	X6135	VO-110	F4483	VCA-1031	G7062	VO-129	P2476	VA-146
X4006	VO-58	X6160	VO-121	F4489C	VCA-1135	G7064	VO-102	P2484	VA-162
X4011	VO-55	X6161	VO-122	F4517	VCA-1035	G7078	VO-103	P2486	VA-397
X4457	VO-25	X6162	VO-116	F4524	VCA-1110	G7079	VO-78	P2487	VA-259
X4459	VO-106	X6291	VO-123	F4600	VCA-1115	G7082	VO-76	P2488	VA-324
X4460	VO-106	X6311	VO-102	F4683	VCA-1041	G7083	VO-77	P2524	VA-140
X4466	VO-15	X7662	VO-52	F4684	VCA-1047	G7090	VO-67	P2551	VA-193
X4476	VO-40	X8113	VO-77	F4685	VCA-1146	G7107	VO-144	P2564	VA-165
X4477	VO-40	X85	VO-37	F4687	VCA-1102	G7171	VO-128	P2612	VA-207
X4484	VO-60	X8812	LC-834	F4689	VCA-1066	G7171B	VO-112	P2625	VA-363
X4610	VO-106	ECOGUARD SYNTHETIC		F4773	VCA-1001	G7173	VO-87	P2641	VA-394
X4612	VO-106	S10002	VO-131	F4780	VCA-1002	G7186	VO-85	P2725	VA-160
X4615	VO-106	S10040	VO-114	F4794	VCA-1053	G7187	VO-85	P2727	VA-345
X4619	VO-35	S10436	VO-168	F4805	VCA-1003	G7189	VO-131	P2728	VA-150
X4631	VO-56	S10479	VO-106	F4807	VCA-1008	G7203	VO-80	P2729	VA-161
X4651	VO-88	S111	VO-16	F4812	VCA-1022	G7204	VO-92	P2731	VA-174

CAUTION: For general references only. Check catalog for correct filter application. Any use of this interchange to determine filter application is done at the installers risk.

PRECAUCION: Solamente para referencias generales. Revise el catálogo para la correcta aplicación del filtro. Cualquier uso de la referencia cruzada para determinar la aplicación del filtro es riesgo del instalador. ATTENTION : Seulement pour les références d'ordre général. Contrôler l'application correcte du filtre avec le catalogue. Toute utilisation de moyens afin de déterminer l'application d'un filtre est faite aux risques de l'installateur.

Cross Reference

Table da equivalencias da fabricantes

Code de renvoi au fabricant

MFR'S NUMBER	REPLACEMENT NUMBER	MFR'S NUMBER	REPLACEMENT NUMBER	MFR'S NUMBER	REPLACEMENT NUMBER	MFR'S NUMBER	REPLACEMENT NUMBER	MFR'S NUMBER	REPLACEMENT NUMBER
FACTORY MOTOR PARTS									
P2737	VA-379	P6221	VA-153	P6889	VA-187	P9155	VA-248	P9800	VA-385
P2740	VA-172	P6242	VA-389	P6902	VA-176	P9156	VA-228	P9825	VA-326
P2749	VA-350	P6244	VA-414	P6914	VA-198	P9157	VA-343	P9830	VA-457
P2750	VA-179	P6245	VA-84	P6916	VA-356	P9158	VA-296	P9843	VA-318
P2752	VA-377	P6253	VA-148	P6917	VA-269	P9172	VA-209	P9846	VA-329
P2793	VA-149	P6255	VA-260	P6924	VA-197	P9175	VA-243	P9873	VA-375
P2797	VA-152	P6271	VA-411	P6930	VA-264	P9184	VA-218	P9876	VA-349
P2799	VA-199	P6272	VA-387	P6935	VA-224	P9185	VA-353	P9883	VA-223
P2800	VA-355	P6273	VA-111	P6938	VA-314	P9186	VA-226	P9886	VA-239
P2822	VA-400	P6289	VFAP-7892	P6975	VA-186	P9187	VA-249	P9888	VA-373
P2823	VA-352	P6293	VA-89	P9000	VA-238	P9191	VA-240	P9890	VA-241
P2825	VA-190	P6301	VA-111	P9001	VA-282	P9192	VA-229	P9893	VA-246
P2826	VA-340	P6302	VA-110	P9004	VA-358	P9200	VA-294	P9894	VA-254
P2831	VA-188	P6303	VA-109	P9005	VA-368	P9201	VA-253	P9901	VA-267
P2834	VA-208	P6308	VA-113	P9006	VA-378	P9208	VA-443	P9902	VA-266
P2838	VA-386	P6316	VA-128	P9009	VA-291	P9210	VA-283	P9907	VA-341
P2839	VA-337	P6318	VA-412	P9010	VA-234	P9211	VA-393	P9926	VA-154
P2843	VA-180	P6320	VA-131	P9014	VA-290	P9220	VA-184	P9933	VA-232
P2844	VA-202	P6322	VFAP-7865	P9016	VA-245	P9223	VA-214	P9946	VA-272
P2846	VA-177	P6327	VA-170	P9017	VA-288	P9224	VA-351	R0001	VO-123
P2859	VA-204	P6339	VA-124	P9018	VA-258	P9225	VA-244	R1036	VO-55
P2863	VA-362	P6340	VFAP-1613	P9020	VA-274	P9229	VA-364	R1040	VO-16
P2864	VA-336	P6349	VA-346	P9022	VA-300	P9230	VA-275	R1042	VO-58
P2879	VA-359	P6358	VFAP-1612	P9023	VA-278	P9235	VA-326	R1060	VO-56
P2885	VA-194	P6388	VFAP-7908	P9031	VA-292	P9240	VA-445	R1060	VO-56
P2891	VA-151	P6390	VA-135	P9034	VA-442	P9244	VA-327	R1069	VO-65
P2897	VA-90	P6398	VA-120	P9038	VA-401	P9247	VA-302	R1085	VO-95
P2972	VA-325	P6406	VA-338	P9040	VA-221	P9250	VA-265	R1088	VO-15
P3120	VA-237	P6416	VFAP-1643	P9041	VA-220	P9264	VA-427	R1224	VO-143
P4627127AB	VA-303	P6417	VA-114	P9042	VA-202	P9270	VA-366	R1228	VO-86
P6006	VFAP-7859	P6418	VA-93	P9043	VA-313	P9288	VA-299	R1228	VO-86
P6017	VA-102	P6419	VA-94	P9048	VA-310	P9293	VA-354	R1258	VO-108
P6026	VA-103	P6425	VFA-1641	P9049	VA-287	P9310	VA-309	R1311	VO-95
P6027	VA-97	P6428	VA-112	P9051	VA-328	P9314	VA-295	R1315	VO-118
P6028	VA-104	P6440	VA-404	P9052	VA-227	P9320	VA-257	R1334A	VO-106
P6030	VA-401	P6441	VA-92	P9053	VA-216	P9344	VA-315	R1334B	VO-106
P6035	VA-91	P6443	VA-320	P9054	VA-211	P9362	VA-332	R1342	VO-15
P6036	VA-44	P6444	VA-117	P9056	VA-323	P9400	VA-268	R1348	VO-25
P6040	VA-38	P6462	VA-118	P9057	VA-233	P9429	VA-219	R1355	VO-93
P6044	VA-261	P6463	VA-178	P9058	VA-252	P9459	VA-388	R1356	VO-106
P6053	VA-370	P6464	VA-136	P9059	VA-372	P9460	VA-250	R1361	VO-25
P6057	VA-99	P6465	VA-339	P9063	VA-184	P9461	VA-317	R1365	VO-106
P6058	VA-158	P6472	VA-159	P9064	VA-217	P9468	VA-423	R1372	VO-88
P6064	VA-83	P6484	VA-116	P9065	VA-212	P9475	VA-280	R1381	VO-19
P6077	VA-90	P6493	VA-410	P9066	VA-360	P9475933	VA-425	R1392	VO-27
P6080	VA-107	P6503	VA-279	P9067	VA-213	P9480	VA-334	R1394	VO-40
P6081	VA-129	P6573	VA-65	P9069	VA-201	P9498	VA-263	R1452	VO-15
P6083	VA-98	P6646	VA-169	P9070	VA-235	P95021102	VA-424	R1515	VO-1
P6088	VA-269	P6648	VA-191	P9073	VA-312	P9530	VA-297	R1516	VO-118
P6093	VA-88	P6653	VA-122	P9085	VA-374	P9545	VA-367	R1522	VO-108
P6095	VFAP-7857	P667P	VA-335	P9086	VA-242	P9555	VA-444	R1607	VO-64
P6097	VA-416	P6673	VA-166	P9094	VA-435	P9570	VA-391	R1620	VO-56
P6098	VA-106	P6677	VA-163	P9100	VA-383	P9590	VA-426	R1620	VO-56
P6105	VFAP-7893	P6678	VA-155	P9102	VA-236	P9593	VA-446	R1626	VO-35
P6108	VA-101	P6699	VA-324	P9104	VA-231	P9600	VA-384	R1734	VO-63
P6109	VA-125	P6728	VA-156	P9110	VA-378	P9604	VA-284	R1742	VO-46
P6116	VA-86	P6798	VA-167	P9113	VA-230	P9610	VA-390	R6174	VA-70
P6117	VA-108	P6799	VA-347	P9114	VA-215	P9630	VA-307	R7046	VO-52
P6120	VA-40	P6802	VA-132	P9115	VA-200	P9634	VA-225	R7060	VO-88
P6126	VA-66	P6803	VA-192	P9116	VA-251	P9640	VA-319	R7099	VO-65
P6128	VA-413	P6804	VA-270	P9117	VA-203	P9670	VA-311	R7099	VO-65
P6134	VA-205	P6814	VA-182	P9119	VA-210	P9704	VA-452	R7143	VO-122
P6144	VFAP-917	P6831	VA-205	P9120	VA-237	P9727	VA-255	R7145	VO-147
P6153A	VA-78	P6832	VA-183	P9121	VA-202	P9728	VA-447	R7145	VO-147
P6153B	VA-78	P6834	VA-184	P9122	VA-365	P9730	VA-285	R7151	VO-104
P6162	VA-96	P6835	VA-171	P9123	VA-357	P9737	VA-286	R7202	VO-75
P6174	VA-70	P6873	VA-330	P9136	VA-382	P9739	VA-296	R7241	VO-124
P6180	VA-85	P6879	VA-206	P9143	VA-448	P9746	VA-293	R7502	VO-88
P6195	VA-144	P6887	VA-189	P9145	VA-222	P9750	VA-304	R7521	VO-161
P6213	VA-105	P6888	VA-175	P9146	VA-289	P9756	VA-273	R7561	VO-101
			VA-195	P9154	VA-381	P9760	VA-305	R7712	VO-106

CAUTION: For general references only. Check catalog for correct filter application. Any use of this interchange to determine filter application is done at the installers risk.
 PRECAUCION: Solamente para referencias generales. Revise el catálogo para la correcta aplicación del filtro. Cualquier uso de la referencia cruzada para determinar la aplicación del filtro es riesgo del instalador. ATTENTION : Seulement pour les références d'ordre général. Contrôler l'application correcte du filtre avec le catalogue. Toute utilisation de moyens afin de déterminer l'application d'un filtre est faite aux risques de l'installateur.

Cross Reference

Table da equivalencias da fabricantes

Code de renvoi au fabricant

MFR'S NUMBER	REPLACEMENT NUMBER	MFR'S NUMBER	REPLACEMENT NUMBER	MFR'S NUMBER	REPLACEMENT NUMBER	MFR'S NUMBER	REPLACEMENT NUMBER	MFR'S NUMBER	REPLACEMENT NUMBER
FACTORY MOTOR PARTS									
R7899	VO-88	AF258F	VFAP-7859	LF279F	VO-56	A770X-6714-GA	VO-52	DORY-6731-A	VO-15
R96985730	VO-123	AF291F	VFAP-7859	LF299F	VO-63	A770X-6714-HA	VO-15	DR3Z-19N619-A	VCA-1102
V14P	VG-2	AF307F	VA-89	LF379F	VO-95	A780X-6714-AA	VO-52	DS7Z-9601-A	VA-306
V3046	VG-2	AF361F	VA-125	LF384F	VO-40	A780X-6714-MA	VO-52	DS7Z-9601-D	VA-306
V3097	VG-16	AF385F	VA-412	LF385F	VO-25	A780X-6714-NA	VO-52	D0NN-6714-A	VO-1
V3296	VG-32	AF391F	VA-112	LF386F	VO-106	A800X-6714-FA	VO-15	D1PJ-6714-AA	VO-15
V3311	VG-33	AF411F	VFAP-7893	LF391F	VO-35	A800X-9601-AA	VO-15	D1PJ-6714-AA	VO-25
V3481	VG-14	AF417F	VA-114	LF396F	VO-55	BC3Z-6731-A	VO-104	D1PZ-6731-A	VO-15
V3484	VG-30	AF439F	VA-120	LF402F	VO-37	BC3Z-6731-B	VO-104	D1RY-6731-A	VO-95
V4580	VG-30	AF445F	VA-111	LF408F	VO-106	BC3Z-9601-A	VA-266	D2AE-9155-CA	VG-2
V880B	VG-16	AF463F	VFAP-1612	LF410F	VO-64	BC34-9601-AC	VA-266	D2PJ-6714-AA	VO-52
		AF481F	VFAP-1612	LF410F	VO-40	BC34-9601-BA	VA-382	D2TZ-6731-A	VO-52
		AF484F	VFAP-1613	LF413F	VO-40	BE8Z-19N619-A	VCA-1177	D2TZ-6731-ADP	VO-52
AF1014F	VFAP-1643	AF484F	VA-94	LF441F	VO-46	BE8Z-6731-AB	VO-25	D3AZ-9155-A	VG-2
AF1016F	VFA-1641	AF509F	VA-404	LF461F	VO-106	BE8Z-6731-AC	VO-25	D3AZ-9155C	VG-2
AF1026F	VA-131	AF513F	VA-92	LF462F	VO-60	BE8Z-9601-AA	VA-284	D3VE-9155-AB	VG-2
AF1030F	VA-135	AF724F	VA-411	LF479F	VO-150	BF5T-6731-AA	VO-1	D3VE-9155-A4A	VG-2
AF1031F	VFAP-7908	AF777F	VA-402	LF483F	VO-118	BM5G-6714-AA	VO-25	D4ZZ-6731-B	VO-95
AF1032F	VA-260	AF805F	VA-69	LF484F	VO-106	B7A-6731-A	VO-1	D5ZZ-6731-A	VO-95
AF1034F	VA-153	AF809F	VA-45	LF487F	VO-108	B7A-6731-B	VO-1	D69Z-9601A	VA-429
AF1037F	VA-117	AF826F	VA-38	LF489F	VO-67	B8A-6731-A	VO-1	D8AE-9D695-A	VA-34
AF1039F	VA-118	AF838F	VA-44	LF490F	VO-95	B9AE-6714-A2	VO-1	D8AZ-9D695-A	VA-34
AF1040F	VA-91	AF842F	VA-40	LF491F	VO-106	B9AE-6714-A6	VO-1	D8NN-6714-EA	VO-1
AF1041F	VA-144	AF868F	VA-85	LF493F	VO-15	B9AE-6714-B	VO-1	D8NN-6714-GA	VO-1
AF1044F	VA-116	AF873F	VA-65	LF494F	VO-25	B9LE-6714-A	VO-1	D8PJ-6714-AA	VO-95
AF1045F	VA-410	AF878F	VA-205	LF508F	VO-64	CCICZ-6731-E	VO-134	D8RZ-6731-A	VO-15
AF1052F	VA-259	AF879F	VA-413	LF509F	VO-65	CC0Z-6714-AG	VO-95	D8TZ-6731-A	VO-52
AF1061F	VA-146	AF880F	VA-66	LF510F	VO-86	CC1AZ-6731-A	VO-1	D9AE-6714-AA	VO-1
AF1062F	VA-136	AF882F	VA-86	LF517F	VO-15	CC1CZ-6731-E	VO-134	D9AZ-6731-A	VO-1
AF1070F	VA-152	AF892F	VFAP-917	LF522F	VO-66	CC1CZ-6731-F	VO-108	D9FL-6731-B	VO-1
AF1072F	VA-137	AF894F	VA-408	LF523F	VO-106	CC3CZ-6731-B	VO-108	D9NN-6714-EA	VO-1
AF1074F	VA-191	AF897F	VA-70	LF524F	VO-75	CC3CZ-6731-C	VO-56	ECG-6714-A	VO-1
AF1077F	VA-151	AF899F	VA-90	LF530F	VO-69	CC3CZ-6731-D	VO-65	ECCZ-6714-A	VO-1
AF1079F	VA-142	AF925F	VA-84	LF548F	VO-76	CC3RZ-9601-C	VA-321	ECCZ-6714-C	VO-1
AF1080F	VA-122	AF951F	VA-88	LF558F	VO-81	CJ5Z-9601-A	VA-298	EC3Z-9601-B	VA-463
AF1082F	VA-150	AF953F	VA-78	LF561F	VO-78	CK4Z-9601-A	VA-451	EDC-6714-A	VO-1
AF1083F	VA-149	AF954F	VA-269	LF563F	VO-25	CN1Z-9601-A	VA-284	EDG-6714-A	VO-1
AF1084F	VA-140	AF958F	VA-416	LF565F	VO-106	COAE-6714-A	VO-1	EDG-6714-C	VO-1
AF1085F	VA-159	AF976F	VA-83	LF594F	VO-80	COAE-6731-A	VO-1	ESE95-AE9601-AA	VA-410
AF1101F	VA-156	AF977F	VA-96	LF604F	VO-85	COLE-6714-A	VO-1	E0HZ-6731-A	VO-56
AF1102F	VA-193	AF979F	VA-101	LF608F	VO-64	CO1E-6714-B	VO-1	E1EE-6714-AA	VO-118
AF1103F	VA-154	AF98F	VA-107	LF613F	VO-88	CV6Z-19N619-A	VCA-1081	E1FZ-6731-A	VO-118
AF1108F	VA-155	AF981F	VA-97	LF615F	VO-90	CV6Z-9601-A	VA-288	E1NN-6714-BA	VO-15
AF1109F	VA-169	AF984F	VA-98	LF618F	VO-87	COAE-6714-B	VO-1	E1NN-6714-BB	VO-15
AF1112F	VA-149	AF987F	VA-102	LF669F	VO-116	COLE-6714-A	VO-1	E1NN-6731-BA	VO-25
AF1119F	VA-324	AF988F	VA-124	FORD		C1AZ-6731-A	VO-1	E1PZ-6731-A	VO-15
AF1121F	VA-165	AF990F	VA-103	AA5Z-6714-AA	VO-88	C1AZ-6731-AP	VO-1	E1ZE-6714-AA	VO-1
AF1125F	VA-78	AF992F	VA-108	AA5Z-6714-AB	VO-88	C3AE-6714-A	VO-1	E2PJ-6714-AA	VO-46
AF1127F	VA-162	AF993F	VFAP-7854	AE5Z-19N619-A	VCA-1059	C3NN-6714-A	VO-1	E2PJ-6714-CA	VO-52
AF1128F	VA-164	AF994F	VA-93	AE81-9601-AA	VA-284	C3RZ-6731-A	VO-56	E27E-6714-A1A	VO-1
AF1130F	VA-167	GF111F	VG-14	AE9Z-19N619-A	VCA-1114	C3RZ-6731-B	VO-108	E3EE-9155-C	VG-16
AF1133F	VA-163	LFF477F	VO-93	AH42-9601-AA	VA-446	C3RZ-6731-C	VO-65	E3EE-9155-CB	VG-16
AF1134F	VA-196	LF107F	VO-95	AR3Z-9601-B	VA-253	C4AE-6714-A	VO-1	E3EE-9155-CC	VG-16
AF1135F	VA-161	LF110F	VO-88	AV61-9601-AD	VA-288	C4AF-6714-A	VO-1	E3FZ-9155-C	VG-16
AF1139F	VA-160	LF113F	VO-106	A690X-6A692-RA	VO-25	C4RF-6731-B	VO-134	E3HZ-6731-A	VO-162
AF1156F	VA-183	LF115F	VO-1	A700X-6714-CA	VO-15	C4RZ-6731-C	VO-65	E3TZ-6731-A	VO-46
AF1333F	VA-223	LF134F	VO-118	A700X-6714-EA	VO-95	C5AZ-9155-A	VG-2	E3TZ-6731-C	VO-35
AF136F	VA-105	LF142F	VO-95	A700X-6714-SA	VO-1	C5UC-9155-A	VG-2	E3TZ-9601-C	VA-411
AF137F	VA-104	LF144F	VO-19	A700X-6714-UA	VO-108	C5UE-9155-A	VG-2	E3TZ-9601-K	VA-411
AF1434F	VA-265	LF145F	VO-27	A710X-6714-CA	VO-1	C5UZ-9155-A	VG-2	E3TZ-9601-L	VA-411
AF1440F	VA-202	LF157F	VO-25	A710X-6714-DA	VO-95	C6JZ-6714-A	VO-95	E3ZE-6714-CA	VO-95
AF145F	VA-2	LF164F	VO-108	A720X-6714-HA	VO-108	C6JZ-6714-B	VO-95	E4FZ-6731-A	VO-118
AF148F	VFAP-7857	LF196F	VO-95	A720X-6714-JA	VO-108	C7NN-6714-A	VO-1	E4FZ-6731-AB	VO-118
AF150F	VA-106	LF222F	VO-108	A720X-6714-LA	VO-15	C7NN-6714-B	VO-1	E4FZ-6731-BB	VO-118
AF1519F	VA-299	LF224F	VO-56	A720X-6714-MA	VO-95	C7NN-6714-BS	VO-1	E4FZ-9601-A	VA-69
AF157F	VA-403	LF225F	VO-65	A720X-6714-SA	VO-65	C8AF-6714-A	VO-1	E4NN-6714-AA	VO-95
AF190F	VA-110	LF230F	VO-108	A720X-6714-UA	VO-25	C9PJ-6714-A	VO-15	E4TZ-6731-A	VO-95
AF209F	VA-109	LF232F	VO-58	A740X-6714-FA	VO-95	DG9Z-19N619-A	VCA-1174	E43E-6714-A4A	VO-63
AF213F	VA-113	LF233F	VO-16	A760X-6714-FA	VO-52	DG9Z-19N619-AA	VCA-1174	E55E-9155-A	VG-16
AF2242F	VA-411	LF238F	VO-15	A760X-6714-LA	VO-25	DG9Z-9601-A	VA-429	E5TE-9601-AB	VA-205
AF244F	VFAP-7892	LF240F	VO-106	A760X-6714-SA	VO-52	DIRY-6731-A	VO-95	E5TZ-6731-A	VO-136

CAUTION: For general references only. Check catalog for correct filter application. Any use of this interchange to determine filter application is done at the installers risk.

PRECAUCION: Solamente para referencias generales. Revise el catálogo para la correcta aplicación del filtro. Cualquier uso de la referencia cruzada para determinar la aplicación del filtro es riesgo del instalador. ATTENTION : Seulement pour les références d'ordre général. Contrôler l'application correcte du filtre avec le catalogue. Toute utilisation de moyens afin de déterminer l'application d'un filtre est faite aux risques de l'installateur.

Cross Reference

Table da equivalencias da fabricantes

Code de renvoi au fabricant

MFR'S NUMBER	REPLACEMENT NUMBER	MFR'S NUMBER	REPLACEMENT NUMBER	MFR'S NUMBER	REPLACEMENT NUMBER	MFR'S NUMBER	REPLACEMENT NUMBER	MFR'S NUMBER	REPLACEMENT NUMBER
FORD		F5UZ-9601-A	VA-120	000-6731-F	VO-134	6M5G-6744-AA	VO-85	CA10173	VA-222
E5TZ-9601-B	VA-205	F50Y-9601-A	VA-94	000-6731-G	VO-108	6M5Y-9601-AA	VA-314	CA10190	VA-231
E55E-9155-AA	VG-16	F50Z-9601-BA	VA-94	1C3Z-9601-AA	VA-167	691M6714AA	VO-15	CA10191	VA-243
E59E-9601-A	VA-69	F57X-9601-AA	VA-114	1L2Z-9601-AA	VA-162	7C3Z-9601-A	VA-223	CA10192	VA-213
E59E-9601-AA	VA-69	F57Z-9601-A	VA-114	1S7E-6714-BA	VO-25	7C3Z-9601-B	VA-239	CA10193	VA-340
E59Z-9601-A	VA-69	F57Z-9601-AA	VA-114	1S7E-6714-CA	VO-25	7C3Z-9601C	VA-223	CA10217	VA-329
E6AE-9601-BC	VA-66	F59Z-9601-A	VA-69	1S7G-6714-DA	VO-25	7S7G-6714-EA	VO-25	CA10228	VA-232
E6AZ-9601-B	VA-66	F6DZ-19N619-BA	VCA-1001	1S7J-6744-AC	VO-80	7T16-9601-AA	VA-140	CA10233	VA-242
E6DZ-9601-A	VA-404	F6DZ-19N619-C	VCA-1001	1S7J-6744-MC	VO-80	7T16-9601-AB	VA-140	CA10234	VA-244
E6DZ-9601-B	VA-404	F6DZ-9601-A	VFAP-7854	1S7Z-6731-DA	VO-25	7T4Z19N619A	VCA-1049	CA10236	VA-204
E6SZ-9601-B	VA-413	F6DZ-9601-B	VA-404	1072246	VA-140	7T4Z-19N619-B	VCA-1049	CA10242	VA-224
E7DE-6714-A1A	VO-118	F6RZ-9601-CB	VFAP-1612	11425472	VO-95	7T4Z-9601-A	VA-224	CA10253	VA-314
E7DZ-9155-A	VG-16	F6ZZ-9601-A	VA-94	11-525802	VO-95	7166160	VFAP-1613	CA10254	VA-356
E7GZ-6731-A	VO-106	F6ZZ-9601-AA	VA-94	1343102	VO-80	74HM-6714-CA	VO-95	CA10255	VA-386
E7GZ-6731-B	VO-106	F63X-9601-BB	VFAP-1613	140516040	VO-15	77BM-6714-AA	VO-15	CA10256	VA-318
E7NN-6714-AA	VO-1	F65Z-19N619-AB	VCA-1017	140516060	VO-15	77BM-6714-C1A	VO-25	CA10257	VA-353
E7NN-6714-DA	VO-95	F67X-9601-AA	VFA-1641	1541456	VCA-1177	8L8Z-19N619-B	VCA-1104	CA10261	VA-264
E7TE-9601-AC	VA-70	F67Z-9601-AA	VFA-1641	1665410	VFAP-1612	8S4Z-9601-A	VA-241	CA10262	VA-223
E7TZ-9600-A	VA-411	F7CZ-9601-A	VFAP-1643	2L2Z-9601-AC	VA-322	8V51-18D543-AA	VCA-1177	CA10270	VA-239
E7TZ-9601-A	VA-411	F7DZ-19N619-AB	VCA-1001	2R8H-18D483-AA	VCA-1131	8W93-6A692-AC	VO-141	CA10271	VA-230
E7TZ-9601-B	VA-70	F7DZ-9155-A	VG-16	2R8H-19N619-AA	VCA-1131	8OMF-6731-AA	VO-162	CA10286	VA-374
E73Z-6731-B	VO-35	F7OZ-9155-A	VG-16	2W93-9155-AA	VG-14	83EM6714BA	VO-35	CA10324	VA-367
E8NN-6714-AA	VO-95	F77Z-9601-AA	VA-260	2735E-6714-B	VO-15	89FF-6714-A2E	VO-118	CA10328	VA-365
E8NN-6714-BA	VO-1	F8CZ-6731-AA	VO-118	3C3Z-6731-AA	VO-81	89FF-6714-A2E	VO-118	CA10330	VA-349
E8NN-6714-CA	VO-95	F8CZ-6731-BA	VO-118	3C3Z-6731AB	VO-81	9C2E-6714-AA	VO-25	CA10343	VA-234
E83C-9B072-AA	VG-16	F81A-9601-AA	VA-410	3C3Z-9601-BA	VA-174	9L8Z-9601-A	VA-246	CA10344	VA-252
E9AE-6714-B	VO-1	F81Z-9601-AB	VA-410	3F1Z-19N619-AA	VCA-1001	9T1Z-9601-A	VA-267	CA10346	VA-238
E9FE-9601-AB	VA-88	GN1Z-9601-A	VA-501	3MYZ-6714-AA	VO-80	9W7E-6714-AA	VO-25	CA10347	VA-289
E9GZ-6731-A	VO-106	GU2Z-6731-A	VO-64	3M21-6744-AA	VO-77	9W7Z-6714-AA	VO-25	CA10348	VA-258
E9NN-6714-AA	VO-95	HC3Z-9601-A	VA-462	3M4G-6744-AA	VO-80	9W7Z-6731-A	VO-25	CA10349	VA-233
E9SZ-9601-A	VA-88	HC3Z-9601-B	VA-463	3M5Q-6744-AA	VO-111	9Z8M6714A2A	VO-15	CA10359	VA-237
E9TA-9B072-CA	VG-16	MC1	VO-65	3S7Z-6731A	VO-80	93BB9600AH	VFAP-1612	CA10418	VA-326
E9ZZ-6731-A	VO-106	MHK-6714-A	VO-1	3W7E-6714-AA	VO-88	93BB-9601-AB	VFAP-1612	CA10464	VA-323
E9ZZ-9B072	VG-16	R1V	VO-65	3W7Z-6714-AA	VO-88	93BB9601AB	VFAP-1612	CA10465	VA-255
FL3Z-19N619A	VCA-1185	SBA140516060	VO-15	3W7Z-6714-AB	VO-88	93BW-19N619-AC	VCA-1157	CA10466	VA-219
FR3Z-19N619-A	VCA-1186	SBA140516110	VO-15	3898985	VA-114	938M-6714-A1A	VO-95	CA10467	VA-221
FR3Z-9601-A	VA-430	SBA140517020	VO-25	4C3Z-9601-AA	VA-174	96JV-6714-AA	VO-86	CA10468	VA-220
FR8Z-19N619AA	VCA-1157	XC3Z-9601-AA	VA-122	4F1Z-9N619-AA	VCA-1104	97MM-6714-B1A	VO-25	CA10470	VA-235
FT4Z-6731-A	VO-115	XF2H-19N619-AC	VCA-1008	4F2Z-6714-AA	VO-118	97VV-6714AA	VO-15	CA10488	VA-241
F0NN-6714-BA	VO-40	XF2Z-19N619-AB	VCA-1008	4H2Z-6731-AA	VO-86	978M6714B1A	VO-15	CA10490	VA-343
F0TE-9155-AA	VG-32	XF2Z-9601-AC	VA-114	4H23-6714-BA	VO-86	978M-6714-B4A	VO-118	CA10491	VA-381
F0TZ-9155-B	VG-32	XF5Z-6731-AA	VO-106	4H23-6714-CA	VO-86	978M-6714-C3A	VO-118	CA10494	VA-360
F1AE-6714-BC	VO-88	XH4Z-6714-CA	VO-74	4L3Z-9601-BA	VA-182	98AB-9601-CB	VA-140	CA10495	VA-362
F1AZ-6731-A	VO-88	XM21-6744-AA	VO-71	4M5H-18D543-AA	VCA-1172	98AX-9601-AA	VA-140	CA10497	VA-278
F1AZ-6731-BD	VO-88	XM34-6731-AA	VO-145	4M5Q-6714-CA	VO-52	FRAM		CA10500	VA-315
F1CZ-9601-A	VA-416	XR8E-6714-AB	VO-118	4R3U-9601-AB	VA-186	BA3525	VA-34	CA10516	VA-245
F1Z2-6731-B	VO-106	XR8E-6714-AC	VO-118	4R3Z-19N619-AA	VCA-1102	BA3631	VA-48	CA10522	VA-313
F23Z-6731-B	VO-106	XS4Z-19N619-AA	VCA-1163	4R3Z-9601-AA	VA-186	CA10013	VA-202	CA10539	VA-240
F23Z-9601-B	VFAP-7854	XS61-9155-AA	VG-16	4STJ-6744-AA	VO-80	CA10014	VA-200	CA10540	VA-372
F3HZ-6731-A	VO-64	XW4E-6714-BA	VO-88	4W4Z-9N619-BA	VCA-1131	CA10015	VA-210	CA10542	VA-282
F3HZ-6731-B	VO-64	XW4E-6714-DA	VO-88	436936	VO-95	CA10022	VA-337	CA10543	VA-379
F3HZ-6731-C	VO-64	XW4E-6714-EA	VO-118	5C3Z-9601-AA	VA-382	CA10064	VA-377	CA10544	VA-332
F3XY-6731-A	VO-25	XW4H-19N619-AA	VCA-1125	5F9Z-9601-AA	VA-197	CA10071	VA-382	CA10551	VA-351
F3XY-9601-A	VFAP-7857	XW4U-9601-AA	VA-142	5M6U-9601-AB	VA-249	CA10083	VA-228	CA10566	VA-364
F3Z2-6731-A	VO-106	XW4Z-19N619-AC	VCA-1125	5M6Z-19N619-AA	VCA-1101	CA10084	VA-227	CA10578	VA-357
F3Z2-9601-A	VA-106	XW4Z-6731-BA	VO-86	5M6Z-9601-AA	VA-249	CA10085	VA-226	CA10591	VA-375
F4FZ-6731-AB	VO-118	XW4Z-9601-AA	VA-142	5M6Z-9601-AB	VA-249	CA10086	VA-208	CA10616	VA-246
F4TZ-6731-A	VO-63	XW4Z-9601-AB	VA-142	5019408	VA-157	CA10088	VA-201	CA10626	VA-263
F4ZX-9601-AC	VA-89	XW4Z-9601-AC	VA-142	542957	VO-95	CA10092	VA-216	CA10633	VA-368
F4ZZ-9601-A	VA-89	XW4Z-9601-AD	VA-142	58125	VO-162	CA10093	VA-217	CA10650	VA-250
F43X-9601-BB	VFAP-1613	XW43-6714-BA	VO-86	59WV-18660	VO-1	CA10094	VA-215	CA10656	VA-383
F5OY-9601-A	VA-94	YC3Z-9601-AA	VA-94	6C1Q-6744AA	VO-111	CA10110	VA-225	CA10661	VA-358
F5RZ-19N619-B	VCA-1157	YF1Z-9155-AA	VG-16	6E5Z-9601-EA	VA-215	CA10115	VA-236	CA10662	VA-371
F5RZ-19N619-BA	VCA-1157	YF1Z-9601-AA	VA-149	6E5Z-9601-GA	VA-216	CA10118	VA-229	CA10675	VA-373
F5RZ-19N619-C	VCA-1157	YL4J-6714-BA	VO-155	6E5Z-9601-AE	VA-215	CA10159	VA-251	CA10676	VA-317
F5RZ-6731-A	VO-95	YL8Z-19N619-AB	VCA-1020	6E5Z-9601-GA	VA-216	CA10161	VA-218	CA10677	VA-309
F5RZ-6731-B	VO-95	YL8Z-9155-AA	VG-16	6E53-9601-EA	VA-215	CA10163	VA-248	CA10680	VA-384
F5RZ-9601-B	VFAP-1613	YL8Z-9601-AA	VA-149	6G9N-19N619BA	VCA-1108	CA10165	VA-212	CA10685	VA-254
F5RZ-9601-C	VFAP-1612	YL84-19N619-A	VCA-1020	6G9N-6744-BA	VO-85	CA10169	VA-209	CA10690	VA-280
F5R9601C	VFAP-1612	YL84-19N619-AA	VCA-1020	6G9Q-6744-AA	VO-111	CA10170	VA-249	CA10692	VA-388
F5TZ-9601-A	VA-93	YS4Z-9601-CC	VA-140	6L2Z-9601-AA	VA-222	CA10171	VA-214	CA10693	VA-316

CAUTION: For general references only. Check catalog for correct filter application. Any use of this interchange to determine filter application is done at the installers risk.

PRECAUCION: Solamente para referencias generales. Revise el catálogo para la correcta aplicación del filtro. Cualquier uso de la referencia cruzada para determinar la aplicación del filtro es riesgo del instalador. ATTENTION : Seulement pour les références d'ordre général. Contrôler l'application correcte du filtre avec le catalogue. Toute utilisation de moyens afin de déterminer l'application d'un filtre est faite aux risques de l'installateur.

Cross Reference

Table da equivalencias da fabricantes

Code de renvoi au fabricant

MFR'S NUMBER	REPLACEMENT NUMBER	MFR'S NUMBER	REPLACEMENT NUMBER	MFR'S NUMBER	REPLACEMENT NUMBER	MFR'S NUMBER	REPLACEMENT NUMBER	MFR'S NUMBER	REPLACEMENT NUMBER
FRAM		CA11500	VA-311	CA6366	VA-70	CA8548	VA-178	CA9681	VA-206
CA10694	VA-447	CA11501	VA-424	CA6395	VA-84	CA8601	VA-397	CA9683	VA-195
CA10699	VA-268	CA11541	VA-490	CA6479	VA-78	CA8602	VA-138	CA9687	VA-182
CA10720	VA-366	CA11712	VA-419	CA6555	VA-88	CA8606	VA-116	CA9689	VA-400
CA10741	VA-257	CA11858	VA-438	CA6626	VA-269	CA8609	VA-108	CA9708	VA-363
CA10755	VA-273	CA11876	VA-453	CA6690	VA-401	CA8612	VA-339	CA9711	VA-274
CA10781	VA-253	CA11877	VA-434	CA6690	VA-96	CA8613	VA-159	CA9762	Dodge VA-179
CA10785	VA-354	CA11895	VA-440	CA6807	VA-83	CA8713	VA-350	CA9778	VA-181
CA10798	VA-378	CA11942	VA-417	CA6821	VA-158	CA8715	VFAP-7912	CA9798	VA-359
CA10800	VA-378	CA11943	VA-418	CA6828	VA-416	CA8720	VA-394	CA9806	VA-355
CA10802	VA-294	CA11945	VA-431	CA6849	VA-370	CA8747	VA-156	CA9838	VA-180
CA10834	VA-267	CA11946	VA-451	CA6850	VA-97	CA8754	VA-78	CA9875	VA-211
CA10839	VA-385	CA11948	VA-428	CA6900	VA-261	CA8755	VA-271	CA9894	VA-319
CA10867	VA-296	CA11949	VA-432	CA7094	VA-101	CA8755A	VA-324	CA9895	VA-186
CA10881	VA-265	CA11958	VA-430	CA7142	VA-99	CA8756	VA-259	CA9898	VA-207
CA10885	VA-275	CA11959	VA-425	CA7167	VA-98	CA8760	VA-270	CA9900	VA-187
CA10888	VA-266	CA11960	VA-460	CA7174	VA-103	CA8766	VA-152	CA9902	VA-188
CA10889	VA-283	CA11970	VA-452	CA7246	VA-395	CA8768	VA-132	CA9912	VA-330
CA10910	VA-437	CA12050	VA-464	CA7344	VA-104	CA8805	VA-137	CA9944	VA-197
CA10957	VA-273	CA12051	VA-454	CA7351	VA-102	CA8817	VA-164	CA9948	VA-269
CA10989	VA-296	CA12052	VA-466	CA7365	VA-404	CA8911	VA-165	CA9953	VA-336
CA10990	VA-285	CA12057	VA-465	CA7365	VFAP-7854	CA8918	VA-146	CA9969	VA-203
CA10994	VA-443	CA12061	VA-456	CA7414	VA-107	CA8922	VA-190	CA9997	VA-198
CA10996	VA-445	CA12064	VA-468	CA7417	VFAP-7859	CA8925	VA-122	CF10132	VCA-1014
CA10997	VA-284	CA12065	VA-458	CA7420	VA-113	CA8956	VA-142	CF10133	VCA-1028
CA10999	VA-391	CA12066	VA-455	CA7421	VA-108	CA8969	VA-140	CF10134	VCA-1063
CA11010	VA-390	CA12071	VA-488	CA7426	VA-106	CA8970	VA-166	CF10135	VCA-1012
CA11011	VA-396	CA12085	VA-459	CA7431	VA-124	CA8997	VA-149	CF10136	VCA-1164
CA11033	VA-295	CA12091	VA-461	CA7432	VA-112	CA9007	VFAP-7865	CF10137	VCA-1020
CA11034	VA-272	CA12112	VA-471	CA7438	VA-93	CA9053	VA-155	CF10138	VCA-1067
CA11042	VA-291	CA12166	VA-467	CA7440	VA-105	CA9054	VA-154	CF10139	VCA-1042
CA11048	VA-290	CA12168	VA-470	CA7597	VA-109	CA9055	VA-345	CF10140	VCA-1068
CA11049	VA-327	CA12182	VA-462	CA7598	VA-110	CA9073	VA-333	CF10141	VCA-1030
CA11050	VA-286	CA12183	VA-463	CA7600	VA-338	CA9113	VA-150	CF10157	VCA-1133
CA11052	VA-293	CA12258	VA-469	CA7605	VA-128	CA9115	VA-191	CF10218	VCA-1046
CA11053	VA-334	CA12260	VA-474	CA7614	VA-120	CA9269	VA-169	CF10245	VCA-1054
CA11053A	VA-334	CA12289	VA-500	CA7620	VA-132	CA9277	VA-346	CF10285	VCA-1031
CA11062	VA-446	CA12290	VA-497	CA7626	VA-125	CA9286	VA-151	CF10329	VCA-1066
CA11109	VA-310	CA12295	VA-498	CA7628	VFAP-7857	CA9288	VA-90	CF10360	VCA-1074
CA11113	VA-292	CA12369	VA-501	CA7630	VA-387	CA9332	VA-162	CF10361	VCA-1065
CA11114	VA-288	CA12373	VA-499	CA7640	VA-111	CA9345	VA-161	CF10362	VCA-1162
CA11116	VA-265	CA12404	VA-505	CA7651	VA-157	CA9359	VA-170	CF10362	VCA-1162
CA11118	VA-444	CA160	VA-321	CA7730	VA-89	CA9360	VA-163	CF10363	VCA-1170
CA11121	VA-297	CA192	VA-402	CA7737	VFAP-1613	CA9361	VA-192	CF10364	VCA-2033
CA11170	VA-287	CA3187	VA-321	CA7738	VFAP-1612	CA9379	VA-279	CF10368	VCA-1124
CA11206	VA-300	CA326	VA-2	CA7764	VA-135	CA9392	VA-193	CF10369	VCA-1127
CA11215	VA-301	CA327	VA-403	CA7774	VA-114	CA9400	VA-167	CF10370	VCA-1102
CA11222	VA-426	CA3492	VA-45	CA8014	VFAP-7912	CA9401	VA-160	CF10373	VCA-1135
CA11227	VA-299	CA3501	VA-411	CA8037	VA-320	CA9409	VA-325	CF10374	VCA-1037
CA11250	VA-473	CA3559	VA-40	CA8038	VA-92	CA9435	VA-199	CF10381	VCA-1035
CA11251	VA-308	CA3588	VA-38	CA8039	VA-94	CA9441	VA-172	CF10382	VCA-1165
CA11257	VA-293	CA3647	VA-44	CA8040	VFAP-7908	CA9459	VA-335	CF10383	VCA-1145
CA11258	VA-307	CA3660	VA-69	CA8067	VFAP-7859	CA9471	VA-342	CF10435	VCA-1108
CA11259	VA-302	CA3874	VA-84	CA8069	VA-144	CA9481	VA-270	CF10545	VCA-1052
CA11298	VA-331	CA3901	VA-90	CA8080	VA-157	CA9482	VA-171	CF10546	VCA-1146
CA11305	VA-450	CA3902	VA-85	CA8121	VA-147	CA9492	VA-176	CF10547	VCA-1049
CA11413	VA-393	CA3914	VFAP-917	CA8127	VA-412	CA9493	VA-196	CF10548	VCA-1104
CA11420	VA-392	CA3916	VA-65	CA8133	VA-117	CA9501	VA-399	CF10549	VCA-1110
CA11422	VA-423	CA4309	VA-86	CA8141	VFA-1641	CA9502	VA-361	CF10550	VCA-1034
CA11426	VA-344	CA4576	VA-389	CA8142	VFAP-1643	CA9516	VA-174	CF10553	VCA-1041
CA11431	VA-303	CA4939	VA-408	CA8162	VA-131	CA9525	VA-247	CF10554	VCA-1096
CA11439	VA-442	CA5034	VA-2	CA8188	VA-148	CA9555	VA-185	CF10555	VCA-1039
CA11450	VA-312	CA5056	VA-205	CA8205	VA-129	CA9563	VA-322	CF10557	VCA-1155
CA11453	VA-435	CA5057	VA-413	CA8208	VA-153	CA9564	VA-183	CF10559	VCA-1117
CA11456	VA-298	CA5058	VA-66	CA8220	VA-341	CA9565	VA-328	CF10560	VCA-1123
CA11469	VA-427	CA5125	VA-414	CA8221	VA-91	CA9589	VA-177	CF10561	VCA-1131
CA11476	VA-304	CA5350	VFAP-7865	CA8243	VA-260	CA9600	VA-184	CF10562	VCA-1129
CA11477	VA-305	CA5436	VFAP-7912	CA8269	VA-410	CA9603	VA-175	CF10709	VCA-1047
CA11480	VA-306	CA5466	VFAP-7892	CA8295	VA-347	CA9636	VA-352	CF10719	VCA-1138
CA11482	VA-429	CA5595	VFAP-7893	CA8475	VA-118	CA9662	VA-189	CF10727	VCA-1103
CA11494	VA-457	CA5777	VA-380	CA8547	VA-136	CA9669	VA-194	CF10728	VCA-1051

CAUTION: For general references only. Check catalog for correct filter application. Any use of this interchange to determine filter application is done at the installers risk.

PRECAUCION: Solamente para referencias generales. Revise el catálogo para la correcta aplicación del filtro. Cualquier uso de la referencia cruzada para determinar la aplicación del filtro es riesgo del instalador. ATTENTION : Seulement pour les références d'ordre général. Contrôler l'application correcte du filtre avec le catalogue. Toute utilisation de moyens afin de déterminer l'application d'un filtre est faite aux risques de l'installateur.

Cross Reference

Table da equivalencias da fabricantes

Code de renvoi au fabricant

MFR'S NUMBER	REPLACEMENT NUMBER	MFR'S NUMBER	REPLACEMENT NUMBER	MFR'S NUMBER	REPLACEMENT NUMBER	MFR'S NUMBER	REPLACEMENT NUMBER	MFR'S NUMBER	REPLACEMENT NUMBER
FRAM		CF8791	VCA-1003	CH9911	VO-85	PH5618	VO-86	PRA160	VA-321
CF10729	VCA-1069	CF8804	VCA-1022K	CH9954	VO-85	PH6010A	VO-106	PRA192	VA-402
CF10730	VCA-1050	CF8804A	VCA-1165	CH9955	VO-128	PH6022	VO-25	PRA326	VA-2
CF10731	VCA-1109	CF8813	VCA-1013	CH9972	VO-84	PH6065A	VO-25	PRA327	VA-403
CF10732	VCA-1144	CF8921	VCA-1008	CH9994	VO-140	PH6355	VO-136	PRA3492	VA-45
CF10734	VCA-1053	CF9118	VCA-1163	CH9999	VO-90	PH6607	VO-106	PRA3588	VA-38
CF10735	VCA-1062	CF9597A	VCA-1168	G22A	VG-2	PH6811	VO-106	PRA3647	VA-44
CF10742	VCA-1075	CF9846	VCA-1014	G3727	VG-14	PH6813	VO-143	PRA3902	VA-85
CF10744	VCA-1113	CF9905	VCA-1126	G3727DP	VG-14	PH6941	VO-135	PRA4939	VA-408
CF10745	VCA-1114	CH10066	VO-111	G3802A	VG-16	PH7317	VO-106	PRA6850	VA-97
CF10746	VCA-1147	CH10075	VO-91	G3802ADP	VG-16	PH7328	VO-95	PRA7438	VA-93
CF10747	VCA-1093	CH10158	VO-87	G3850	VG-32	PH7575	VO-25	PRA7440	VA-105
CF10775	VCA-1078C	CH10160	VO-92	G3850DP	VG-32	PH8A	VO-1	PRA7730	VA-89
CF10776	VCA-1115	CH10246	VO-98	G7315	VG-33	PH8212	VO-60	PRA7774	VA-114
CF10896	VCA-1072	CH10295	VO-96	G7315DP	VG-33	PH8316	VO-118	PRA8039	VA-94
CF10900	VCA-1036	CH10323	VO-129	G7333	VG-30	PH8830	VO-124	FRAM (X2) EXTENDED GUARD	
CF10930	VCA-1055	CH10358	VO-102	G7333DP	VG-30	PH8873	VO-65	XG10060	VO-88
CF10934	VCA-1153	CH10415	VO-97	HPH3690	VO-161	PH8936	VO-146	XG10575	VO-88
CF11171	VCA-1139	CH10515	VO-99	HPH3690FP	VO-161	PH8994	VO-93	XG16	VO-95
CF11172	VCA-1159	CH10530	VO-112	PH10060	VO-88	PH9010	VO-86	XG2	VO-88
CF11173	VCA-1038	CH10632	VO-138	PH10267	VO-170	PH9100	VO-75	XG2870A	VO-15
CF11174	VCA-1059	CH10759	VO-132	PH10575	VO-88	PH9566	VO-25	XG2951	VO-40
CF11175	VCA-1116	CH10855	VO-109	PH10590	VO-88	PH966B	VO-25	XG30	VO-65
CF11176	VCA-1118	CH10955	VO-110	PH10600	VO-101	PH9688	VO-106	XG3387A	VO-16
CF11177	VCA-1171	CH10992	VO-141	PH10890	VO-104	PH9715	VO-106	XG3506	VO-58
CF11178	VCA-1075	CH11007	VO-131	PH10968	VO-95	PH9837	VO-108	XG3593A	VO-106
CF11182	VCA-1061	CH11060	VO-149	PH11	VO-108	PH9897	VO-52	XG3593A	VO-106
CF11183	VCA-1073	CH11242	VO-133	PH11462	VO-123	PPA3559	VA-40	XG3593A	VO-52
CF11184	VCA-1057	CH11246	VO-151	PH12060	VO-160	PPA3660	VA-69	XG3600	VO-118
CF11279	VCA-1101	CH11252	VO-121	PH13	VO-56	PPA3914	VFAP-917	XG3614	VO-25
CF11663	VCA-1080	CH11473	VO-164	PH16	VO-95	PPA3916	VA-65	XG3675	VO-108
CF11664	VCA-1071	CH11665	VO-114	PH2	VO-88	PPA4309	VA-86	XG3682	VO-25
CF11667	VCA-1076	CH11675	VO-165	PH2FP	VO-88	PPA5056	VA-205	XG3786	VO-63
CF11668	VCA-1077	CH11784	VO-117	PH25	VO-108	PPA5057	VA-413	XG3950	VO-19
CF11670	VCA-1177	CH11790	VO-153	PH2815	VO-15	PPA5058	VA-66	XG3980	VO-55
CF11671	VCA-1064	CH11794	VO-142	PH2825	VO-15	PPA5466	VFAP-7892	XG3985	VO-35
CF11672	VCA-1094	CH11885	VO-166	PH2849A	VO-52	PPA6366	VA-70	XG43	VO-95
CF11775	VCA-1174	CH11934	VO-167	PH2870A	VO-15	PPA6555	VA-88	XG4967	VO-40
CF11776	VCA-1082	CH11955	VO-115	PH2921	VO-19	PPA6626	VA-269	XG5	VO-56
CF11777	VCA-1097	CH12056	VO-168	PH2931	VO-86	PPA6690	VA-401	XG6607	VO-106
CF11809	VCA-1173	CH12059	VO-169	PH2951	VO-40	PPA6690	VA-96	XG7317	VO-106
CF11811	VCA-1175	CH12069	VO-172	PH2995	VO-86	PPA6807	VA-83	XG8	VO-1
CF11819	VCA-1075	CH12246	VO-173	PH30	VO-65	PPA7094	VA-101	XG8481	VO-103
CF11854	VCA-1178	CH200PL	VO-134	PH3381	VO-1	PPA7344	VA-104	XG9018	VO-76
CF11920	VCA-1081	CH3970	VO-37	PH3387A	VO-16	PPA7351	VA-102	XG9100	VO-75
CF11921	VCA-1089	CH5320	LC-834	PH3506	VO-58	PPA7365	VFAP-7854	XG9641	VO-80
CF11924	VCA-1120	CH6847	VO-70	PH3531	VO-27	PPA7414	VA-107	XG9688	VO-106
CF11925	VCA-1134	CH6848	VO-62	PH3545	VO-163	PPA7421	VA-108	XG9837	VO-108
CF11966	VCA-1183	CH7073	LC-833	PH3569	VO-15	PPA7426	VA-106	XG9972	VO-84
CF12000	VCA-1176	CH7732	VO-144	PH3593A	VO-106	PPA7432	VA-112	XG9999	VO-90
CF12002	VCA-1179	CH8081	LC-8170	PH3593A	VO-106	PPA7597	VA-109	FRAM CORE	
CF12058	VCA-1191	CH8087	LC-8445	PH3593A	VO-52	PPA7598	VA-110	COR10060TLE	VO-88
CF12150	VCA-1185	CH8158	VO-150	PH3600	VO-118	PPA7626	VA-125	COR16TLE	VO-95
CF12151	VCA-1181	CH8213	VO-74	PH3614	VO-25	PPA7640	VA-111	COR2TLE	VO-88
CF12160	VCA-1190	CH8278	VO-127	PH3639	VO-15	PPA8040	VFAP-7908	COR3387TLE	VO-16
CF12214	VCA-2055	CH8481	VO-69	PH3675	VO-108	PPA8133	VA-117	COR3506TLE	VO-58
CF12307	VCA-2051	CH8530	VO-71	PH3682	VO-25	PPA8205	VA-129	COR3593ATLE	VO-106
CF5816A	VCA-1150	CH8712	VO-66	PH3757	VO-162	PPA8221	VA-91	COR3593ATLE	VO-106
CF8046	VCA-1157	CH8765	VO-67	PH3766	VO-46	PPA8243	VA-260	COR3593ATLE	VO-52
CF8109	VCA-1001	CH8806	VO-73	PH3786	VO-63	PPA8602	VA-138	COR3614TLE	VO-25
CF8249	VCA-1122	CH9018	VO-76	PH3950	VO-19	PPA8606	VA-116	COR3682TLE	VO-25
CF8327	VCA-1021	CH9024	VO-120	PH3976A	VO-64	PPA8755A	VA-324	COR3786TLE	VO-63
CF8392	VCA-1002	CH9232	VO-137	PH3980	VO-55	PPA8756	VA-259	COR4967TLE	VO-40
CF8603	VCA-1167	CH9301	VO-69	PH3985	VO-35	PPA8925	VA-122	COR5TLE	VO-56
CF8631	VCA-1017	CH9447	VO-78	PH43	VO-95	PPA9400	VA-167	COR6607TLE	VO-106
CF8644	VCA-1026	CH9461	VO-77	PH4386	VO-40	PPA9589	VA-177	COR9018TLE	VO-76
CF8644A	VCA-1166	CH9549	VO-81	PH4681	VO-15	PPA9687	VA-182	COR9688TLE	VO-106
CF8714	VCA-1161	CH9584	VO-82	PH4704	VO-156	PPA9762	VA-179	FRAM HIGH MILEAGE	
CF8718	VCA-1040	CH9641	VO-80	PH4967	VO-40	PPA9778	VA-181	HM10060	VO-88
CF8762	VCA-1060	CH9690	VO-94	PH5	VO-56	PPA9838	VA-180	HM10575	VO-88
CF8769	VCA-1024	CH9713	VO-116	PH5343	VO-106	PPA9895	VA-186	HM16	VO-95

CAUTION: For general references only. Check catalog for correct filter application. Any use of this interchange to determine filter application is done at the installers risk.

PRECAUCION: Solamente para referencias generales. Revise el catálogo para la correcta aplicación del filtro. Cualquier uso de la referencia cruzada para determinar la aplicación del filtro es riesgo del instalador. ATTENTION : Seulement pour les références d'ordre général. Contrôler l'application correcte du filtre avec le catalogue. Toute utilisation de moyens afin de déterminer l'application d'un filtre est faite aux risques de l'installateur.

Cross Reference

Table da equivalencias da fabricantes

Code de renvoi au fabricant

MFR'S NUMBER	REPLACEMENT NUMBER	MFR'S NUMBER	REPLACEMENT NUMBER	MFR'S NUMBER	REPLACEMENT NUMBER	MFR'S NUMBER	REPLACEMENT NUMBER	MFR'S NUMBER	REPLACEMENT NUMBER
FRAM HIGH MILEAGE		FPCA3492	VA-45	FPCA8956	VA-142	FPCF10545	VCA-1052	FP3506	VO-58
HM2	VO-88	FPCA3588	VA-38	FPCA8969	VA-140	FPCF10546	VCA-1146	FP3593A	VO-106
HM2870A	VO-15	FPCA3647	VA-44	FPCA8970	VA-166	FPCF10547	VCA-1049	FP3600	VO-118
HM2951	VO-40	FPCA3660	VA-69	FPCA8997	VA-149	FPCF10548	VCA-1104	FP3614	VO-25
HM30	VO-65	FPCA3901	VA-90	FPCA9007	VFAP-7865	FPCF10549	VCA-1110	FP3682	VO-25
HM3387A	VO-16	FPCA3902	VA-85	FPCA9053	VA-155	FPCF10550	VCA-1034	FP3766	VO-46
HM3506	VO-58	FPCA3914	VFAP-917	FPCA9054	VA-154	FPCF10553	VCA-1041	FP3786	VO-63
HM3593A	VO-106	FPCA3916	VA-65	FPCA9113	VA-150	FPCF10554	VCA-1096	FP3950	VO-19
HM3593A	VO-52	FPCA4309	VA-86	FPCA9115	VA-191	FPCF10559	VCA-1117	FP3976A	VO-64
HM3600	VO-118	FPCA4939	VA-08	FPCA9269	VA-169	FPCF10719	VCA-1138	FP3980	VO-55
HM3614	VO-25	FPCA5056	VA-205	FPCA9286	VA-151	FPCF10727	VCA-1103	FP3985	VO-35
HM3675	VO-108	FPCA5058	VA-66	FPCA9332	VA-162	FPCF10728	VCA-1051	FP43	VO-95
HM3682	VO-25	FPCA5125	VA-414	FPCA9345	VA-161	FPCF10729	VCA-1069	FP4386	VO-147
HM3976A	VO-64	FPCA5466	VFAP-7892	FPCA9359	VA-170	FPCF10734	VCA-1053	FP4967	VO-40
HM3980	VO-55	FPCA5595	VFAP-7893	FPCA9360	VA-163	FPCF10743	VCA-1044	FP5	VO-56
HM3985	VO-35	FPCA6366	VA-70	FPCA9361	VA-192	FPCF10744	VCA-1113	FP5320	LC-834
HM43	VO-95	FPCA6395	VA-84	FPCA9392	VA-193	FPCF10775	VCA-1078C	FP5618	VO-86
HM4386	VO-40	FPCA6690	VA-401	FPCA9400	VA-167	FPCF10930	VCA-1055	FP6607	VO-106
HM4967	VO-40	FPCA6690	VA-96	FPCA9401	VA-160	FPCF11171	VCA-1139	FP6848	VO-62
HM5	VO-56	FPCA6807	VA-83	FPCA9441	VFAP-7892	FPCF11173	VCA-1038	FP7317	VO-106
HM7317	VO-106	FPCA6850	VA-97	FPCA9481	VA-270	FPCF11174	VCA-1059	FP8A	VO-1
HM8A	VO-1	FPCA6900	VA-261	FPCA9482	VA-171	FPCF11175	VCA-1116	FP8081	LC-8170
HM9688	VO-106	FPCA7094	VA-101	FPCA9492	VA-176	FPCF11176	VCA-1118	FP8158	VO-150
HM9837	VO-108	FPCA7174	VA-103	FPCA9493	VA-196	FPCF11177	VCA-1171	FP8212	VO-60
FRAM PRO		FPCA7344	VA-104	FPCA9516	VA-174	FPCF11183	VCA-1073	FP8213	VO-74
FPCA10013	VA-202	FPCA7351	VA-102	FPCA9525	VA-247	FPCF11663	VCA-1080	FP8316	VO-118
FPCA10014	VA-200	FPCA7365	VA-404	FPCA9555	VA-185	FPCF11668	VCA-1077	FP8481	VO-103
FPCA10015	VA-210	FPCA7365	VFAP-7854	FPCA9563	VA-322	FPCF11775	VCA-1174	FP8481	VO-69
FPCA10083	VA-228	FPCA7417	VFAP-7859	FPCA9564	VA-183	FPCF11776	VCA-1082	FP8530	VO-71
FPCA10084	VA-227	FPCA7420	VA-113	FPCA9589	VA-177	FPCF11777	VCA-1097	FP8712	VO-66
FPCA10085	VA-226	FPCA7421	VA-108	FPCA9600	VA-184	FPCF11809	VCA-1173	FP8765	VO-67
FPCA10086	VA-208	FPCA7431	VA-124	FPCA9662	VA-189	FPCF11811	VCA-1175	FP8806	VO-73
FPCA10088	VA-201	FPCA7432	VA-112	FPCA9669	VA-194	FPCF11819	VCA-1075	FP8873	VO-65
FPCA10092	VA-216	FPCA7440	VA-105	FPCA9681	VA-206	FPCF11920	VCA-1081	FP8994	VO-93
FPCA10093	VA-217	FPCA7597	VA-109	FPCA9683	VA-195	FPCF11966	VCA-1184	FP9018	VO-76
FPCA10094	VA-215	FPCA7598	VA-110	FPCA9687	VA-182	FPCF12000	VCA-1176	FP9100	VO-75
FPCA10110	VA-225	FPCA7614	VA-120	FPCA9762	VA-179	FPCF8109A	VCA-1001	FP9549	VO-81
FPCA10115	VA-236	FPCA7626	VA-125	FPCA9778	VA-181	FPCF8327A	VCA-1021	FP9584	VO-82
FPCA10118	VA-229	FPCA7628	VFAP-7857	FPCA9838	VA-180	FPCF8392A	VCA-1002	FP9641	VO-80
FPCA10159	VA-251	FPCA7730	VA-89	FPCA9895	VA-186	FPCF8603A	VCA-1167	FP9688	VO-106
FPCA10161	VA-218	FPCA7764	VA-135	FPCA9898	VA-207	FPCF8631A	VCA-1017	FP9837	VO-108
FPCA10165	VA-212	FPCA7774	VA-114	FPCA9902	VA-188	FPCF8644A	VCA-1026	FP9897	VO-52
FPCA10169	VA-209	FPCA8037	VA-320	FPCA9944	VA-197	FPCF8718A	VCA-1040	FP9911	VO-85
FPCA10171	VA-214	FPCA8038	VA-92	FPCA9948	VA-269	FPCF8791A	VCA-1003	FP9954	VO-85
FPCA10173	VA-222	FPCA8039	VA-94	FPCA9969	VA-203	FPCF8804A	VCA-1022	FP9955	VO-128
FPCA10190	VA-231	FPCA8040	VFAP-7908	FPCA9997	VA-198	FPCF8813A	VCA-1013	FP9972	VO-84
FPCA10191	VA-243	FPCA8069	VA-144	FPCF10132	VCA-1014	FPCF8921A	VCA-1008	FP9999	VO-90
FPCA10192	VA-213	FPCA8080	VA-157	FPCF10133	VCA-1028	FPCF9118A	VCA-1163	FRAM PRO SYNTHETIC	
FPCA10193	VA-340	FPCA8127	VA-412	FPCF10134	VCA-1063	FPCF9119A	VCA-1029	FPS10060	VO-88
FPCA10228	VA-232	FPCA8133	VA-117	FPCF10135	VCA-1012	FPCF9597A	VCA-1010	FPS10075	VO-91
FPCA10233	VA-242	FPCA8141	VFA-1641	FPCF10137	VCA-1020	FP10060	VO-88	FPS10575	VO-88
FPCA10234	VA-244	FPCA8142	VFAP-1643	FPCF10138	VCA-1067	FP10075	VO-91	FPS16	VO-95
FPCA10242	VA-224	FPCA8205	VA-129	FPCF10139	VCA-1042	FP10158	VO-87	FPS2	VO-88
FPCA10261	VA-264	FPCA8208	VA-153	FPCF10140	VCA-1068	FP10246	VO-98	FPS2870A	VO-15
FPCA10262	VA-223	FPCA8221	VA-91	FPCF10141	VCA-1030	FP10295	VO-96	FPS3387A	VO-16
FPCA10343	VA-234	FPCA8243	VA-260	FPCF10157	VCA-1133	FP10323	VO-129	FPS3593A	VO-106
FPCA10344	VA-252	FPCA8475	VA-118	FPCF10218	VCA-1046	FP10358	VO-102	FPS3600	VO-118
FPCA10346	VA-238	FPCA8548	VA-178	FPCF10285	VCA-1031	FP10415	VO-97	FPS3614	VO-25
FPCA10349	VA-233	FPCA8602	VA-138	FPCF10329	VCA-1066	FP10515	VO-99	FPS3682	VO-25
FPCA10466	VA-219	FPCA8606	VA-116	FPCF10361	VCA-1065	FP10575	VO-88	FPS3786	VO-63
FPCA10467	VA-221	FPCA8747	VA-156	FPCF10362	VCA-1162	FP10855	VO-109	FPS3976A	VO-64
FPCA10468	VA-220	FPCA8754	VA-78	FPCF10363	VCA-1170	FP10890	VO-104	FPS3980	VO-55
FPCA10470	VA-235	FPCA8755A	VA-324	FPCF10364	VCA-2033	FP10930	VCA-1055	FPS4967	VO-40
FPCA10488	VA-241	FPCA8756	VA-259	FPCF10368	VCA-1124	FP10955	VO-110	FPS5	VO-56
FPCA10516	VA-245	FPCA8766	VA-152	FPCF10370	VCA-1102	FP16	VO-95	FPS6607	VO-106
FPCA10539	VA-240	FPCA8805	VA-137	FPCF10371	VCA-1043	FP2	VO-88	FPS7317	VO-106
FPCA10881	VA-265	FPCA8817	VA-164	FPCF10372	VCA-1070	FP25	VO-108	FPS8A	VO-1
FPCA160	VA-321	FPCA8911	VA-165	FPCF10373	VCA-1135	FP2870A	VO-15	FPS8081	LC-8170
FPCA192	VA-402	FPCA8918	VA-146	FPCF10374	VCA-1037	FP30	VO-65	FPS8481	VO-69
FPCA326	VA-2	FPCA8922	VA-190	FPCF10381	VCA-1035	FP3387A	VO-16	FPS8712	VO-66
FPCA327	VA-403	FPCA8925	VA-122	FPCF10388	VCA-1048	FP3506	VO-108	FPS8765	VO-67

CAUTION: For general references only. Check catalog for correct filter application. Any use of this interchange to determine filter application is done at the installers risk.

PRECAUCION: Solamente para referencias generales. Revise el catálogo para la correcta aplicación del filtro. Cualquier uso de la referencia cruzada para determinar la aplicación del filtro es riesgo del instalador. ATTENTION : Seulement pour les références d'ordre général. Contrôler l'application correcte du filtre avec le catalogue. Toute utilisation de moyens afin de déterminer l'application d'un filtre est faite aux risques de l'installateur.

Cross Reference

Table da equivalencias da fabricantes

Code de renvoi au fabricant

MFR'S NUMBER	REPLACEMENT NUMBER	MFR'S NUMBER	REPLACEMENT NUMBER	MFR'S NUMBER	REPLACEMENT NUMBER	MFR'S NUMBER	REPLACEMENT NUMBER	MFR'S NUMBER	REPLACEMENT NUMBER
FRAM PRO SYNTHETIC		TG3980	VO-55	XG3682	VO-25	12576118	VO-65	19112834	VA-347
FPS9018	VO-76	TG4967	VO-40	XG3786	VO-63	12576499	VO-108	19112835	VA-192
FPS9100	VO-75	TG5	VO-56	XG3950	VO-19	12582599	VO-58	19114105	VO-67
FPS9641	VO-80	TG6607	VO-106	XG3976A	VO-64	12587552	VO-108	19114116	VO-75
FPS9688	VO-106	TG7317	VO-106	XG3980	VO-55	12593333	VO-67	19114118	VO-25
FPS9911	VO-85	TG8A	VO-1	XG3985	VO-35	12626224	VO-152	19130294	VCA-1075
FPS9972	VO-84	TG8081	LC-8170	XG43	VO-95	12637242	VO-75	19130403	VCA-1043
FPS9999	VO-90	TG8316	VO-118	XG4967	VO-40	12640445	VO-200	19160302	VO-80
FRAM TOUGH GUARD		TG8481	VO-69	XG5	VO-56	12643711	VO-76	19160306	VA-176
TGA10242	VA-224	TG8765	VO-67	XG6607	VO-106	12667194	VO-160	19160688	VO-1
TGA10262	VA-223	TG8806	VO-73	XG7317	VO-106	12670058	VO-152	19160689	VO-1
TGA160	VA-321	TG9018	VO-76	XG8	VO-1	12674698	VO-160	19160690	VO-95
TGA192	VA-402	TG9100	VO-75	XG8481	VO-103	12677108	VO-75	19160691	Classic Design VO-15
TGA326	VA-2	TG9549	VO-81	XG8712	VO-66	12677877	VO-160	19160692	Classic Design VO-118
TGA3588	VA-38	TG9641	VO-80	XG8765	VO-67	12679114	VO-172	19160693	VO-88
TGA3647	VA-44	TG9688	VO-106	XG9018	VO-76	12690385	VO-88	19160694	Classic Design VO-15
TGA3660	VA-69	TG9837	VO-108	XG9100	VO-75	12693541	VO-201	19160695	Classic Design VO-118
TGA3901	VA-90	TG9911	VO-85	XG9641	VO-80	13271190	VCA-1078	19160696	VO-88
TGA3916	VA-65	TG9972	VO-84	XG9688	VO-106	13271191	VCA-1078C	19161274	VO-1
TGA4309	VA-86	TG9999	VO-90	XG9837	VO-108	13272717	VA-285	19161275	VO-95
TGA5056	VA-205	FRAM ULTRA		XG9911	VO-85	13272719	VA-296	19161736	VCA-1001
TGA5058	VA-66	XGA10010	VA-225	XG9972	VO-84	13272720	VA-285	19161737	VCA-1167
TGA5466	VFAP-7892	XGA10013	VA-202	XG9999	VO-90	13356914	VCA-1183	19161740	VCA-1008
TGA6366	VA-70	XGA10110	VA-225	GENERAL MOTORS		13356914	VCA-1183	19161741	VCA-1020
TGA6479	VA-78	XGA10169	VA-209	A3131C	VA-215	13367308	VA-471	19161742	VCA-1131
TGA7351	VA-102	XGA10171	VA-214	V1119324	VO-95	13503675	VCA-1078	19161743	VCA-1030
TGA7365	VFAP-7854	XGA10190	VA-231	10302760	VCA-1164	13503677	VCA-1078C	19161744	VCA-1012
TGA7421	VA-108	XGA10242	VA-224	10318557	VA-109	13508023	VCA-1184	19161746	VCA-1026
TGA7440	VA-105	XGA10262	VA-223	10340216	VCA-1002	15036141	VA-161	19161747	VCA-1163
TGA7597	VA-109	XGA10465	VA-255	10350737	VA-200	15102546	VA-381	19161748	VCA-1122
TGA7626	VA-125	XGA10755	VA-273	10354942	VA-109	15153904	VA-169	19161749	VCA-1024
TGA7774	VA-114	XGA10881	VA-265	10366901	VA-269	15169849	VG-30	19161750	VCA-1166
TGA8038	VA-92	XGA11114	VA-288	10389652	VA-187	15202408	VA-181	19161751	VCA-1168
TGA8039	VA-94	XGA3901	VA-90	10395221	VCA-1002	15221217	VA-78	19161752	VCA-1068
TGA8221	VA-91	XGA4309	VA-86	12326473	VO-163	15278634	VA-225	19161753	VCA-1157
TGA8243	VA-260	XGA6900	VA-261	12326484	VA-402	15282462	VA-218	19161755	VCA-1029
TGA8606	VA-116	XGA7440	VA-105	12326487	VA-403	15284932	VCA-1002	19161759	VCA-1106
TGA8754	VA-78	XGA7597	VA-109	12334505	VA-48	15284938	VCA-1002	19161763	VCA-1127
TGA8755A	VA-324	XGA8039	VA-94	12337451	VA-70	15284939	VCA-1002	19161765	VCA-1161
TGA8997	VA-149	XGA8243	VA-260	12337462	VA-86	15286805	VA-187	19161766	VCA-1040
TGA9054	VA-154	XGA8755A	VA-324	12337526	VA-389	15287103	VA-360	19161767	VCA-1028
TGA9332	VA-162	XGA8997	VA-149	12337780	VA-90	15511626	VO-163	19161768	VCA-1060
TGA9345	VA-161	XGA9054	VA-154	12339993	VO-40	15875795	VA-263	19161769	VCA-1063
TGA9400	VA-167	XGA9345	VA-161	12339994	VO-25	15893542	VA-211	19161770	VCA-1013
TGA9401	VA-160	XGA9360	VA-163	12339995	VO-40	15908915	VA-271	19161772	VCA-1014
TG10060	VO-88	XGA9401	VA-160	12356646	VA-70	15908916	VA-259	19161773	VCA-1042
TG10158	VO-87	XGA9482	VA-171	12482805	VA-109	15909459	VA-388	19161774	VCA-1067
TG10246	VO-98	XGA9492	VA-176	12487701	VO-108	15913344	VA-296	19161775	VCA-1017
TG10295	VO-96	XGA9683	VA-195	12487702	VO-16	15918221	VA-218	19161779	VCA-1160
TG10358	VO-102	XGA9687	VA-182	12487703	VO-58	15925738	VA-360	19161780	VCA-1133
TG10415	VO-97	XGA9997	VA-198	12489483	VCA-1157	15942429	VA-219	19162248	VO-93
TG10575	VO-88	XG10060	VO-88	12489484	VCA-1001	15950115	VA-169	19162250	VA-186
TG10955	VO-110	XG10075	VO-91	12489485	VCA-1167	15986275	VA-320	19162251	VA-180
TG11665	VO-114	XG10358	VO-102	12489487	VCA-1021	15998574	VA-92	19162253	VA-205
TG11955	VO-115	XG10415	VO-97	12490126	VO-46	19112634	VO-25	19166101	VA-78
TG16	VO-95	XG10575	VO-88	12490127	VO-64	19112637	VO-119	19166105	VA-84
TG2	VO-88	XG10600	VO-101	12490131	VO-56	19112640	VO-77	19166107	VA-412
TG2	VO-88	XG11665	VO-114	12490134	VO-95	19112641	VO-71	19166109	VA-271
TG25	VO-108	XG16	VO-95	12490139	VO-63	19112642	VO-127	19166110	VA-259
TG2870A	VO-15	XG2	VO-88	12490140	VO-65	19112663	VO-106	19166111	VA-324
TG30	VO-65	XG2870A	VO-15	12490142	VO-1	19112773	VA-361	19168266	VO-76
TG3387A	VO-16	XG2951	VO-40	12490145	VO-56	19112794	VA-395	19168267	VO-76
TG3506	VO-58	XG30	VO-65	12490146	VO-56	19112804	VA-193	19184673	VCA-1031
TG3593A	VO-106	XG3387A	VO-16	12490147	VO-16	19112809	VA-345	19185485	VO-102
TG3593A	VO-106	XG3506	VO-58	12490148	VO-55	19112810	VA-174	19187301	VO-56
TG3593A	VO-52	XG3593A	VO-106	12490149	VO-108	19112811	VA-172	19210283	VO-58
TG3600	VO-118	XG3593A	VO-106	12490150	VO-15	19112814	VA-325	19210284	VO-16
TG3614	VO-25	XG3593A	VO-52	12490232	VO-88	19112828	VA-346	19210285	VO-108
TG3675	VO-108	XG3600	VO-118	12490233	VO-118	19112830	VA-339	19210286	VO-55
TG3682	VO-25	XG3614	VO-25	12490234	VO-95	19112831	VA-159	19210335	VO-58
TG3786	VO-63	XG3675	VO-108	12552214	VG-30	19112832	VA-279	19210336	VO-16

CAUTION: For general references only. Check catalog for correct filter application. Any use of this interchange to determine filter application is done at the installers risk.
 PRECAUCION: Solamente para referencias generales. Revise el catálogo para la correcta aplicación del filtro. Cualquier uso de la referencia cruzada para determinar la aplicación del filtro es riesgo del instalador. ATTENTION : Seulement pour les références d'ordre général. Contrôler l'application correcte du filtre avec le catalogue. Toute utilisation de moyens afin de déterminer l'application d'un filtre est faite aux risques de l'installateur.

Cross Reference

Table da equivalencias da fabricantes

Code de renvoi au fabricant

MFR'S NUMBER	REPLACEMENT NUMBER	MFR'S NUMBER	REPLACEMENT NUMBER	MFR'S NUMBER	REPLACEMENT NUMBER	MFR'S NUMBER	REPLACEMENT NUMBER	MFR'S NUMBER	REPLACEMENT NUMBER
GENERAL MOTORS		19254733	VA-236	19385589	VO-166	25010324	VO-108	25096099	VA-69
19210337	VO-108	19254734	VA-221	19385591	VO-117	25010325	VO-58	25096932	VA-78
19210338	VO-55	19254735	VA-220	19385592	VO-174	25010339	VO-40	25097057	VA-205
19236603	VA-340	19254736	VA-245	19385593	VO-165	25010341	VO-95	25097061	VA-66
19236604	VA-198	19254737	VA-250	19385595	VA-378	25010634	VO-58	25097239	VA-413
19236605	VA-202	19254738	VA-239	19385596	VA-311	25010792	VO-16	25097254	VA-321
19236606	VA-226	19254739	VA-349	19385597	VA-455	25010908	VO-55	25097453	VA-269
19236607	VA-201	19254740	VA-264	19385598	VA-451	25011296	VO-27	25098463	VA-108
19236608	VA-212	19256041	VO-58	19385600	VA-461	25011302	VO-86	25098522	VA-84
19236609	VA-213	19256042	VO-16	19385601	VA-462	25011354	VO-52	25098601	VA-402
19236610	VA-229	19256043	Classic Design VO-55	19385604	VA-449	25011441	VO-35	25098603	VA-403
19236611	VA-230	19256044	VO-108	19385605	VA-437	25011520	VO-25	25098604	VA-2
19236612	VA-231	19258493	VO-102	19385607	VA-453	25011574	VO-52	25098766	VA-38
19236613	VA-214	19259030	VA-78	19385609	VA-419	25011759	VO-46	25098845	VA-65
19236616	VO-85	19259086	VA-108	19385612	VA-443	25011902	VO-163	25099116	VA-84
19236617	VO-82	19259100	VA-412	19385613	VA-428	25011997	VO-84	25099118	VA-321
19236618	VO-84	19259103	VA-412	19385614	VA-303	25012306	VO-37	25099136	VA-88
19236619	VO-87	19260345	VO-76	19385616	VA-429	25012436	VO-95	25099149	VA-109
19236620	VO-90	19297024	VO-110	19385617	VA-298	25012679	VO-162	25099253	VA-411
19236621	VA-197	19297945	VA-124	19385618	VA-430	25012760	VO-55	25099343	VA-408
19236622	VA-247	19297946	VA-112	19385619	VA-463	25012760B	VO-55	25099409	VA-408
19236625	VA-207	19301505	VO-153	19385620	VA-267	25013075	VO-95	25099549	VA-96
19236626	VA-208	19303249	VO-67	19385622	VA-464	25013449	VO-15	25099551	VA-414
19236628	VA-194	19303974	VO-88	19385623	VA-454	25013451	VO-52	25099735	VA-110
19236671	VA-328	19303975	VO-88	19385624	VA-431	25013454	VO-56	25099849	VA-412
19236672	VA-355	19305676	VA-273	19385625	VA-456	25013977	VO-56	25121293	VG-33
19236675	VA-399	19305677	VO-109	19385626	VA-465	25014051	VO-88	25121435	VG-14
19236676	VA-206	19305678	VCA-1047	19385627	VA-417	25014155	VO-35	25121468	VG-30
19236678	VA-199	19305679	VCA-1164	19385629	VA-418	25014233	VO-16	25121672	VG-14
19236679	VA-210	19305680	VA-266	19385630	VA-446	25014377	VO-108	25121673	VG-14
19236680	VA-215	19305681	VA-261	19385631	VA-445	25014422	VO-106	25121792	VG-14
19236682	VA-341	19305683	VCA-1049	19385632	VA-302	25014425	VO-60	25121801	VG-30
19236683	VA-216	19305684	VA-278	19385635	VA-452	25014441	VO-25	25121843	VG-33
19236684	VA-195	19314023	VA-259	19385636	VA-438	25014520	VO-88	25121942	VG-33
19236685	VA-248	19316246	VA-244	19385640	VA-440	25014564	VO-40	25147112	VA-83
19238408	VCA-1021	19317651	VO-106	19417555	VCA-1076	25014566	VO-135	25147116	VA-158
19239927	VA-48	19318078	VCA-2043	20815924	VA-381	25014568	VO-106	25147120	VA-416
19254689	VA-171	19324430	Bulk Filter VO-98	20857930	VA-457	25014748	VO-108	25147122	VA-97
19254694	VA-188	19326996	VCA-1047	20862288	VA-299	25014766	VO-143	25147124	VA-261
19254695	VA-271	19330000	VO-88	20871244	VA-327	25014772	LC-833	25147142	VA-105
19254696	VA-259	19332546	VG-14	20901295	VCA-1075	25014820	VO-15	25147148	VA-85
19254697	VA-263	19338039	VCA-1042	20958479	VCA-1080	25014831	VO-56	25160560	VO-55
19254698	VA-169	19346291	VA-273	20972654	VA-308	25040385	VA-38	25160561	VO-56
19254700	VA-209	19346296	VA-288	21018801	VO-76	25040881	VA-44	25161877	VO-106
19254701	VA-254	19346320	VA-265	21999324	VA-203	25040929	VA-38	25161877C	VO-106
19254702	VA-280	19346364	VO-114	22665802	VCA-1030	25041235	VA-321	25161878	VO-106
19254706	VA-295	19346373	VO-92	22676970	VA-176	25041591	VA-40	25161879	VO-106
19254708	VA-285	19346378	VO-128	22679620	VA-175	25041593	VA-40	25161880	VO-40
19254709	VO-81	19346382	VO-112	22716895	VA-109	25042562	VFAP-917	25161882	VO-15
19254710	VO-88	19346388	VO-166	22731072	VA-217	25043317	VA-44	25161947	VO-108
19254711	VO-98	19346389	VO-138	22808781	VCA-1173	25043504	VA-85	25161948	VO-65
19254712	VO-97	19346393	VO-131	22845992	VA-259	25043773	VA-321	25161950	VO-95
19254713	VO-91	19346396	VO-121	22909882	VA-169	25043775	VA-86	25161977	VA-91
19254714	VO-111	19346397	VO-101	22971580	VA-468	25043961	VA-34	25162815	VO-1
19254715	VO-96	19346399	VO-94	23135671	VCA-1184	25050385	VA-38	25162816	VO-118
19254716	VO-99	19346402	VO-140	23279657	VA-474	25055046	VG-14	25165661	VA-86
19254717	VO-103	19346424	VO-86	23281440	VCA-1173	25055052	VG-14	25165664B	VA-84
19254718	VO-101	19346428	VO-19	23321606	VA-467	25055128	VO-14	25165668	VA-83
19254719	VO-104	19346430	VO-124	23335811	VA-255	25055129	VG-14	25165693	VG-30
19254720	VA-241	19346432	VO-147	23349854	VA-324	25055302	VG-16	25166240	VA-90
19254721	VA-222	19361771	VO-75	23393247	VCA-1184	25055480	VG-14	25166241	VA-2
19254722	VA-382	19362206	VA-442	23430312	VA-459	25062055	VA-157	25166243	VA-101
19254724	VA-223	19362208	VA-434	23500828	VO-106	25062072	VA-157	25166938	VG-32
19254725	VA-224	19362234	VA-286	24280347	VO-98	25062209	VA-389	25166957	VA-99
19254726	VA-246	19383103	VA-460	24432415	VO-76	25062212	VA-86	25166958	VFAP-7854
19254727	VA-249	19385579	VO-167	24460713	VO-76	25062220	VA-86	25166959	VA-102
19254728	VA-243	19385583	VO-168	24508572	VA-78	25062320	VA-86	25166960	VA-103
19254729	VA-232	19385585	VO-170	24577608	VA-65	25069098	VFAP-1612	25166962	VA-113
19254730	VA-233	19385586	VO-115	25010082	VO-40	25069099	VFAP-1612	25166963	VA-124
19254731	VA-234	19385587	VO-164	25010251	VO-58	2509216	VA-86	25166964	VA-120
19254732	VA-235	19385588	VO-149	25010276	VO-108	25095333	VA-65	25166965	VA-89

CAUTION: For general references only. Check catalog for correct filter application. Any use of this interchange to determine filter application is done at the installers risk.

PRECAUCION: Solamente para referencias generales. Revise el catálogo para la correcta aplicación del filtro. Cualquier uso de la referencia cruzada para determinar la aplicación del filtro es riesgo del instalador. ATTENTION : Seulement pour les références d'ordre général. Contrôler l'application correcte du filtre avec le catalogue. Toute utilisation de moyens afin de déterminer l'application d'un filtre est faite aux risques de l'installateur.

Cross Reference

Table da equivalencias da fabricantes

Code de renvoi au fabricant

MFR'S NUMBER	REPLACEMENT NUMBER	MFR'S NUMBER	REPLACEMENT NUMBER	MFR'S NUMBER	REPLACEMENT NUMBER	MFR'S NUMBER	REPLACEMENT NUMBER	MFR'S NUMBER	REPLACEMENT NUMBER
GENERAL MOTORS		25313796	VFA-1641	54425938	VCA-1078	6439857	VO-58	88915475	VG-14
25167021	VA-112	25313797	VFAP-1643	55352643	VO-122	6439900	VO-16	88917036	VO-75
25167331	VA-107	25313799	VA-129	55495105	VO-202	6439901	VO-16	88917137	VA-151
25167332	VA-104	25313800	VFAP-7893	55496755	VO-160	6439913	VO-16	88917139	VA-151
25167334	VA-105	25319590	VO-56	55496756	VO-88	6439929	VO-16	88926297	VO-108
25168081	VA-92	25319592	VO-37	55496758	VO-88	6459892	VA-402	88928236	VO-35
25168082	VA-320	25319686	VG-30	55560894	VA-254	648235	VA-402	88928237	VO-52
25168595	VO-95	25320116	VO-118	55565960	VO-153	6483509	VA-403	88928238	VO-108
25169629	VA-88	25320118	VA-260	55577033	VO-153	6483645	VA-403	88929050	VO-58
25170842	VO-16	25320917	VA-116	55584685	VO-98	6483700	VA-402	88944151	VA-187
25170844	VO-16	25320918	VA-117	55588497	VO-98	6483864	VA-402	88969107	VA-171
25171376	VO-55	25320919	VA-118	55594651	VO-98	6484235	VA-2	88969580	VO-40
25171377	VO-55	25322205	VA-401	55594652	VO-98	6484963	VA-403	88970273	VCA-1037
25171792	VG-14	25322829	VO-1	55595791	VO-172	6486234	VA-402	88971573	VO-40
25171899	VO-60	25322830	VO-95	557240	VA-48	6486236	VA-403	88975792	VA-231
25171947	VO-95	25322831	VO-95	5574406	VO-134	6486264	VA-402	88975799	VA-209
25171949	VO-162	25322832	VO-108	5574459	VO-1	6486894	VA-402	88984215	VO-58
25171950	LC-834	25322833	VO-65	5574540	VO-134	6487235	VA-402	88997015	VA-142
25171951	VO-95	25322834	VO-95	5575104	VO-108	6487322	VA-403	88997016	VA-149
25171952	VO-144	25322835	VO-16	5575840	VO-1	6487958	VA-2	88997017	VA-140
251719536	VO-15	25322836	VO-55	5576054	VO-134	649008	VO-52	88997018	VA-149
25171956	VO-70	25322837	VO-25	5577410	VO-108	710319	VO-118	88997020	VA-148
25171957	VO-62	25322838	VO-108	5577618	VO-95	729854	VO-58	88997021	VA-153
25171958	VO-136	25322839	VO-118	5577981	VO-108	729865	VO-108	88997022	VA-136
25172337	VO-60	25322840	VO-106	5578029	VO-56	7884778	VO-15	88997023	VA-138
25175285	VA-93	25322841	VO-56	5578035	VO-56	7965051	VO-25	88997024	VA-146
25175287	VA-98	25322842	VO-25	5578052	VO-65	7984256	VO-25	88997025	VA-137
25175289	VA-106	25323187	VO-37	5578077	VO-65	7984292	VO-1	88997026	VA-350
25175290	VA-84	25324052	VO-65	5578085	VO-65	7984460	VO-15	88997027	VA-190
25175291	VA-370	25325403	VO-55	5578108	VO-65	7984655	VO-15	88997028	VA-270
25175297	VA-125	25325404	VO-16	5578135	VO-56	7984778	VO-15	88997029	VA-152
25175304	VFAP-7857	25325405	VO-65	5579164	VO-95	7984866	VO-52	88997030	VA-150
25175308	VA-387	25325406	VO-25	5651479	VG-2	7988038	VA-403	88997031	VA-155
25175310	VFAP-7859	25325407	VO-1	5651781	VO-1	84000015	VA-485	88997032	VA-154
25175321	VA-96	25325408	VO-95	5715388	VO-56	84121217	VA-505	88997033	VA-147
25175326	VA-111	25325409	VO-56	5725461	VA-402	84262965	VA-469	88997034	VA-410
25175332	VFAP-7892	25325410	VO-108	5745882	VO-75	84390002	VA-474	88997035	VA-122
25177038	VA-338	25325411	VO-95	6419362	VA-402	88894390	VO-78	88997039	VCA-1029
25177053	VFAP-7912	25325412	VO-106	6419892	VA-402	88915317	VA-411	88997056	VO-69
25177055	VA-157	25325413	VO-118	6420934	VA-402	88915319	VA-90	88997057	LC-8170
25177063	VA-128	25325414	VO-108	6423148	VO-56	88915320	VA-320	88997058	VO-74
25177076	VFAP-7865	25325415	VO-25	6424244	VA-48	88915323	VA-66	88997059	VO-66
25177078	VFAP-1613	25325464	VO-37	6429334	VA-402	88915326	VA-412	88997061	LC-8445
25177079	VFAP-1612	25329386	VO-40	6435674	VO-134	88915327	VA-92	88997063	VO-86
25177080	VA-395	25329387	VO-88	6435675	VO-1	88915328	VFAP-917	88997064	VO-86
25177242	VG-32	25329388	VO-58	6435677	VO-108	88915329	VA-108	89002830	VA-380
25177917	VO-67	25329389	VO-58	6435678	VO-108	88915330	VA-65	89017342	VO-108
25177933	VO-63	25329390	VO-108	6435679	VO-65	88915331	VA-110	89017524	VO-88
25195775	VO-173	25329391	VO-40	6436749	VO-1	88915332	VA-65	89017525	VO-88
25195785	VO-173	25329392	VO-88	6437055	VO-65	88915333	VA-69	89017527	VO-88
25311916	VA-259	25332443	VA-324	6437401	VO-108	88915334	VA-78	89028862	VO-65
25311966	VA-114	25654414	VCA-1022	6437461	VO-108	88915336	VA-321	89028863	VO-65
25311967	VA-404	25669930	VCA-1022K	6437462	VO-108	88915338	VA-205	89029265	VO-76
25311968	VFAP-7908	25689297	VCA-1165	6437465	VO-108	88915339	VA-269	89031229	VCA-1008
25311969	VA-135	25728874	VA-335	6437946	VO-56	88915340	VA-70	89031230	VCA-1020
25311970	VA-144	25735595	VA-336	6437955	VO-56	88915341	VA-109	89031231	VCA-1131
25311971	VA-132	25740404	VCA-1043	6437982	VO-15	88915343	VA-40	89031232	VCA-1030
25311974	VA-94	25740406	VCA-1043	6437994	VO-108	88915345	VA-85	89031233	VCA-1012
25312133	VA-271	25798270	VA-335	6437996	VO-108	88915346	VA-402	89034289	VA-394
25312386	VO-67	25798271	VA-336	6438121	VO-1	88915347	VA-2	89034526	VA-178
25313348	VA-259	25815550	VA-218	6438148	VO-56	88915348	VA-2	89034527	VA-397
25313349	VA-271	25839611	VA-218	6438162	VO-25	88915350	VA-45	89034736	VO-145
25313714	VO-15	25899727	VA-255	6438261	VO-65	88915351	VA-38	89034737	VO-19
25313728	VO-15	25906375	VCA-1165	6438868	VO-56	88915352	VA-44	89034919	VO-146
25313729	VO-95	25945274	VA-295	6439109	VO-40	88915427	VA-403	89034925	VO-159
25313730	VO-106	2775215	VA-2	6439120	VO-1	88915428	VG-16	89036837	VO-58
25313731	VO-150	39030321	VA-471	6439143	VO-95	88915463	VG-14	89037127	VO-75
25313733	VO-162	52470574	VCA-1021	6439354	VO-35	88915468	VG-33	89056474	VO-161
25313741	VO-163	52473340	VCA-1003	6439355	VO-19	88915469	VG-30	89058383	VO-80
25313760	VO-1	52485513	VCA-1003	6439517	VO-52	88915471	VG-33	89058384	VO-81
25313795	VA-131	52493319	VCA-1065	6439518	VO-52	88915472	VG-30	89058385	VO-69

CAUTION: For general references only. Check catalog for correct filter application. Any use of this interchange to determine filter application is done at the installers risk.
 PRECAUCION: Solamente para referencias generales. Revise el catálogo para la correcta aplicación del filtro. Cualquier uso de la referencia cruzada para determinar la aplicación del filtro es riesgo del instalador. ATTENTION : Seulement pour les références d'ordre général. Contrôler l'application correcte du filtre avec le catalogue. Toute utilisation de moyens afin de déterminer l'application d'un filtre est faite aux risques de l'installateur.

Cross Reference

Table da equivalencias da fabricantes

Code de renvoi au fabricant

MFR'S NUMBER	REPLACEMENT NUMBER	MFR'S NUMBER	REPLACEMENT NUMBER	MFR'S NUMBER	REPLACEMENT NUMBER	MFR'S NUMBER	REPLACEMENT NUMBER	MFR'S NUMBER	REPLACEMENT NUMBER
GENERAL MOTORS		93156665	VO-106	9975233	VO-15	VA3195	VA-38	VA5192	VA-260
89058389	VA-167	93156666	VO-106	9975243	VO-15	VA3380	VA-44	VA5206	VA-148
89058391	VA-196	93156667	VO-19	GROUP 7		VA3465	VA-69	VA5207	VA-131
89058392	VA-163	93156668	VO-25	C14860P	VCA-1157	VA3546	VA-321	VA5219	VA-144
89058392	VA-165	93156669	VO-95	C15388P	VCA-1003	VA3590	VA-65	VA5227	VA-91
89058393	VA-170	93156656	VO-16	C15389P	VCA-1008	VA3592	VA-66	VA5244	VA-153
89058394	VA-166	93165208	VCA-1150	C15390P	VCA-1167	VA3593	VA-413	VA5248	VA-117
89058395	VA-156	93175492	VO-76	C15439P	VCA-1012	VA4	VA-321	VA5249	VA-118
89058396	VA-191	93175493	VO-76	C15506P	VCA-1160	VA4278	VA-86	VA5257	VA-136
89058397	VG-14	93177787	VO-116	C15510P	VCA-1162	VA4342	VA-85	VA5258	VA-178
89058398	VA-177	93178952	VO-122	C15850P	VCA-1048	VA4343	VA-205	VA5265	VA-116
89058399	VA-164	93182630	VO-106	C15857P	VCA-1036	VA4361	VA-408	VA5266	VA-147
89058400	VA-185	93186554	VO-25	C15873P	VCA-1046	VA4372	VA-90	VA5267	VA-138
89058401	VA-160	93191747	VO-153	C25082P	VCA-1001	VA4378	VA-70	VA5272	VA-410
89058402	VA-342	93193705	VO-40	C25245P	VCA-1002	VA4468	VA-84	VA5278	VA-159
89058403	VA-183	93277239	VFAP-917	C25246P	VCA-1021	VA4479	VA-78	VA5279	VA-339
89058404	VA-184	93441060	VO-56	C25387P	VCA-1162	VA4601	VA-414	VA5290	VA-114
89058406	VA-175	9356538	VO-52	C25478P	VCA-1020	VA4629	VA-408	VA5301	VA-142
89058407	VA-322	93891771	VO-25	C25480P	VCA-1029	VA4632	VA-88	VA5304	VA-315
89058408	VA-182	94020402	VO-15	C25483P	VCA-1161	VA4633	VA-269	VA5305	VA-146
89058410	VA-162	94037791	VO-163	C25490P	VCA-1030	VA4645	VA-96	VA5306	VA-137
89060466	VO-25	94135747	VO-52	C25572P	VCA-1102	VA4646	VA-158	VA5314	VA-259
89060467	VO-65	94149418	VO-106	C25685P	VCA-1104	VA4648	VA-416	VA5323	VA-149
89060468	VO-56	94169778	VO-95	C25764P	VCA-1041	VA4650	VA-101	VA5324	VA-140
89060498	VO-25	94201942	VO-19	C25851P	VCA-1031	VA4669	VA-97	VA5330	VA-78
89060499	VO-65	94217272	VO-35	C25858P	VCA-1064	VA4675	VA-261	VA5352	VA-270
89060500	VO-56	94243270	VO-19	C25863P	VCA-1110	VA4680	VA-83	VA5353	VA-150
8994943	VA-321	94314263	VO-52	C25864P	VCA-1034	VA4688	VA-207	VA5359	VA-151
8995332	VA-411	94345246	VO-40	C25869P	VCA-1069	VA4690	VA-102	VA5363	VA-191
8996093	VA-45	94376355	VA-401	C25870P	VCA-1044	VA4711	VA-340	VA5370	VA-190
8996118	VA-45	94412815	VO-106	C25876P	VCA-1049	VA4712	VFAP-7854	VA5372	VA-156
8997185	VA-48	94455823	VA-86	C35402P	VCA-1122	VA4715	VA-99	VA5373	VA-152
8997189	VA-45	94455838	VA-86	C35425P	VCA-1060	VA4717	VA-98	VA5375	VA-350
9002514	VO-1	94456741	VO-106	C35426P	VCA-1024	VA4720	VA-104	VA5378	VA-111
90220970	VA-157	94459700	VO-106	C35448P	VCA-1022	VA4721	VFAP-7859	VA5381	VA-347
90284766	VA-157	94465656	VA-408	C35473P	VCA-1123	VA4722	VFAP-7892	VA5387	VA-172
90512779	VCA-1029	945539	VO-106	C35479P	VCA-1014	VA4727	VA-105	VA5394	VA-345
90536362	VO-73	94632619	VO-16	C35484P	VCA-1124	VA4731	VA-108	VA5395	VA-193
90537280	VO-76	94775933	VA-425	C35491P	VCA-1028	VA4799	VA-103	VA5396	VA-154
90537438	VO-76	9484246	VO-40	C35494P	VCA-1168	VA4807	VA-370	VA5397	VA-165
90541162	VO-106	94847245	VA-84	C35498P	VCA-1125	VA4819	VA-107	VA5398	VA-170
91151707	VO-106	94847351	VO-40	C35516P	VCA-1014	VA4831	VFAP-7857	VA5400	VA-169
91174457	VA-144	94848478	VO-40	C35518P	VCA-1129	VA4832	VA-106	VA5403	VA-192
91175923	VCA-1160	94849664	VA-414	C35519P	VCA-1063	VA4838	VA-132	VA5405	VA-155
91176162	VO-25	94851858	VO-40	C35526P	VCA-1131	VA4839	VA-387	VA5414	VA-164
9121624	VCA-1150	94851874	VO-40	C35530P	VCA-1068	VA4852	VFAP-917	VA5418	VA-162
9144746	VO-76	94853643	VO-40	C35643P	VCA-1070	VA4855	VA-338	VA5420	VA-166
9162646	VCA-1150	94856888	VFAP-7892	C35644P	VCA-1037	VA4858	VFAP-1612	VA5421	VA-346
9192426	VO-73	94858995	VO-40	C35660P	VCA-1051	VA4859	VFAP-1613	VA5431	VA-176
9194746	VO-76	95021102	VA-424	C35661P	VCA-1035	VA4862	VFAP-7912	VA5432	VA-163
9196120	VA-164	95369731	VCA-1078C	C35667P	VCA-1031	VA4873	VA-113	VA5433	VA-161
92041796	VA-86	96352845	VO-16	C35668P	VCA-1022	VA4877	VA-89	VA5434	VA-185
92066873	VA-375	96389188	VO-52	C35676P	VCA-1065	VA4878	VA-94	VA5440	VA-333
92068246	VO-108	96449577	VCA-1146	C35834P	VCA-1142	VA4879	VA-114	VA5446	VA-167
92101146	VA-78	96458873	VO-16	C35856P	VCA-1050	VA4880	VA-109	VA5449	VA-279
92142003	VO-16	96536696	VA-188	C35865P	VCA-1047	VA4881	VA-110	VA5451	VA-361
92142006	VO-58	96539649	VCA-1146	C36154P	VCA-1078	VA4883	VA-412	VA5456	VA-196
92142009	VO-16	96553450	VA-340	C36179P	VCA-1075	VA4886	VA-125	VA5457	VA-325
92196275	VA-280	96565412	VO-40	C38188P	VCA-1042	VA4995	VA-124	VA5461	VA-199
92229651	VA-280	96570765	VO-40	C38222P	VCA-1067	VA5042	VA-93	VA5462	VA-160
92234714	VCA-1076	96830504	VCA-1146	C45383P	VCA-1026	VA5043	VA-120	VA5463	VA-171
93156093	VO-19	96910360	VA-427	C45384P	VCA-1017	VA5048	VA-112	VA5467	VA-363
93156201	VO-27	96950990	VA-426	C45459P	VCA-1013	VA5049	VFAP-7893	VA5468	VA-205
93156247	VO-19	96962173	VCA-1146	C45508P	VCA-1040	VA5050	VA-128	VA5488	VA-342
93156300	VO-16	96985730	VO-123	C45527P	VCA-1074	VA5089	VA-129	VA5489	VA-322
93156310	VO-16	97049282	VO-162	C45654P	VCA-1043	VA5090	VA-92	VA5497	VA-335
93156321	VO-19	97148270	VO-161	C45662P	VCA-1066	VA5091	VA-320	VA5499	VA-270
93156323	VO-25	97214983	VO-75	C45871P	VCA-1038	VA5105	VFAP-7865	VA5503	VA-183
93156363	VO-15	97600764	VO-163	VA2923	VA-411	VA5148	VFAP-7908	VA5507	VA-184
93156504	VO-1	9974793	VA-69	VA3181	VA-45	VA5150	VA-135	VA5512	VA-177
93156542	VO-35	9975184	VO-52	VA3192	VA-40	VA5155	VFAP-1643	VA5513	VA-175

CAUTION: For general references only. Check catalog for correct filter application. Any use of this interchange to determine filter application is done at the installer's risk.

PRECAUCION: Solamente para referencias generales. Revise el catálogo para la correcta aplicación del filtro. Cualquier uso de la referencia cruzada para determinar la aplicación del filtro es riesgo del instalador. ATTENTION : Seulement pour les références d'ordre général. Contrôler l'application correcte du filtre avec le catalogue. Toute utilisation de moyens afin de déterminer l'application d'un filtre est faite aux risques de l'installateur.

Cross Reference

Table da equivalencias da fabricantes

Code de renvoi au fabricant

MFR'S NUMBER	REPLACEMENT NUMBER	MFR'S NUMBER	REPLACEMENT NUMBER	MFR'S NUMBER	REPLACEMENT NUMBER	MFR'S NUMBER	REPLACEMENT NUMBER	MFR'S NUMBER	REPLACEMENT NUMBER
GROUP 7		VA5819	VA-258	V4484	VO-60	AFC1137	VCA-1022	AFC1460	VCA-1059
VA5517	VA-247	VA5820	VA-236	V4610	VO-106	AFC1138	VCA-1165	AFC1461	VCA-1061
VA5521	VA-189	VA5822	VA-219	V4612	VO-106	AFC1145	VCA-1040	AFC1462	VCA-1050
VA5525	VA-194	VA5824	VA-332	V4615	VO-106	AFC1148	VCA-1020	AFC1472	VCA-1147
VA5528	VA-182	VA5833	VA-240	V4619	VO-35	AFC1151	VCA-1021	AFC1476	VCA-1034
VA5534	VA-206	VA5841	VA-246	V4620	VO-106	AFC1154	VCA-1014	AFC1477	VCA-1071
VA5535	VA-174	VA5850	VA-263	V4622	VO-106	AFC1155	VCA-1043	AFC1478	VCA-1162
VA5538	VA-328	VA5852	VA-270	V4631	VO-56	AFC1157	VCA-1164	AFC1496	VCA-1044
VA5539	VA-380	VA5880	VA-263	V4651	VO-88	AFC1164	VCA-1037	AFC1498	VCA-1097
VA5553	VA-179	VA5907	VA-253	V4670	VO-95	AFC1167	VCA-1166	AFC1500	VCA-1118
VA5556	VA-181	VA6052	VA-250	V4757	VO-62	AFC1203	VCA-1168	AFC1501	VCA-1073
VA5557	VA-330	VA6054	VA-384	V4798	VO-144	AFC1204	VCA-1013	AFC1503	VCA-1062
VA5560	VA-180	VA6061	VA-294	V4872	VO-63	AFC1205	VCA-1028	AFC1504	VCA-1076
VA5566	VA-197	VA6064	VA-202	V49	VO-65	AFC1206	VCA-1030	AFC1506	VCA-1052
VA5567	VA-249	VA6065	VA-388	V5230	VO-118	AFC1207	VCA-1029	AFC1510	VCA-1093
VA5568	VA-186	VA6067	VFA-1641	V5234	VO-85	AFC1213	VCA-1012	AFC1513	VCA-1103
VA5578	VA-195	VA6094	VA-268	V5247	LC-8170	AFC1218	VCA-1024	AFC1516	VCA-1116
VA5582	VA-215	VA6102	VA-280	V5250	VO-150	AFC1223	VCA-1139	AFC1518	VCA-1126
VA5583	VA-216	VA6109	VA-266	V5274	VO-67	AFC1225	VCA-1014	AFC1521	VCA-1094
VA5584	VA-208	VA6114	VA-257	V5276	VO-69	AFC1226	VCA-1054	AFC1522	VCA-1117
VA5585	VA-184	VA6116	VA-273	V5277	VO-103	AFC1229	VCA-1170	AFC1526	VCA-1055
VA5587	VA-377	VA6118	VA-283	V5280	VO-74	AFC1230	VCA-1124	AFC1529	VCA-1057
VA5588	VA-188	VA6119	VA-275	V5288	VO-108	AFC1231	VCA-1074	AFC1533	VCA-1177
VA5589	VA-359	VA6120	VA-267	V5308	VO-71	AFC1235	VCA-1068	AFC1534	VCA-1171
VA5592	VA-198	VA6121	VA-245	V5309	VO-73	AFC1236	VCA-1122	AFC1536	VCA-1077
VA5594	VA-269	VA6124	VA-265	V5313	VO-65	AFC1237	VCA-1096	AFC1550	VCA-1082
VA5596	VA-226	VA6130	VA-254	V5315	VO-66	AFC1238	VCA-1060	AFC1568	VCA-1081
VA5601	VA-228	VA6131	VA-255	V5317	VO-86	AFC1239	VCA-1065	AFC1569	VCA-1153
VA5602	VA-227	VA6140	VA-284	V5317	VO-86	AFC1244	VCA-1063	AFC1571	VCA-1174
VA5603	VA-200	VA6146	VA-295	V5335	VO-64	AFC1245	VCA-1067	AFC1573	VCA-1098
VA5604	VA-217	VA6149	VA-288	V5399	VA-288	AFC1251	VCA-1159	AFC1580	VCA-1120
VA5625	VA-248	VA6151	VA-287	V5401	VO-93	AFC1252	VCA-1042	AFC1582	VCA-1109
VA5626	VA-365	VA6153	VA-291	V5436	VO-76	AFC1260	VCA-1160	AFC1588	VCA-1175
VA5633	VA-222	VA6163	VA-285	V5465	VO-82	AFC1271	VCA-1070	AFC1606	VCA-1144
VA5634	VA-213	VA6171	VA-292	V5476	VO-78	AFC1279	VCA-1155	AFC1621	VCA-1171
VA5635	VA-229	VA6274	VA-307	V5505	VO-80	AFC1282	VCA-1048	AFC1624	VCA-1183
VA5638	VA-218	VA6306	VA-237	V5511	VO-128	AFC1288	VCA-1139	AFC1626	VCA-1173
VA5642	VA-223	VA6308	VA-220	V5515	VO-81	AFC1289	VCA-2033	AFC1631	VCA-1127
VA5647	VA-201	VA6309	VA-221	V5526	VO-81	AFC1294	VCA-1172	AFC1649	VCA-1080
VA5649	VA-214	VA6312	VA-357	V5536	VO-69	AFC1306	VCA-1146	AFC1651	VCA-1110
VA5650	VA-209	VA6313	VA-225	V5545	VO-150	AFC1310	VCA-1133	AFC1654	VCA-1072
VA5651	VA-202	VA6314	VA-264	V5581	VO-85	AFC1312	VCA-1102	AFC1667	VCA-1176
VA5652	VA-343	VA67	VA-402	V5607	VO-91	AFC1315	VCA-1066	AFC1671	VCA-1184
VA5653	VA-212	VA7039	VA-157	V5608	VO-84	AFC1334	VCA-1031	AFC1684	VCA-1186
VA5655	VA-231	VA7492	VA-314	V5609	VO-87	AFC1339	VCA-1035	AFC1688	VCA-1181
VA5656	VA-210	VA91	VA-2	V5610	VO-90	AFC1341	VCA-1048	AFC1737	VCA-2043
VA5657	VA-242	VA92	VA-403	V5646	VO-129	AFC1345	VCA-1049	AFC2539	VCA-1187
VA5669	VA-244	V1A	VO-1	V5692	VO-97	AFC1350	VCA-1047	AF1002	VCA-1157
VA5670	VA-232	V111	VO-16	V5702	VO-96	AFC1352	VCA-1031	AF1004	VCA-1001
VA5671	VA-243	V123	VO-108	V5839	VO-98	AFC1353	VCA-1036	AF1007	VCA-1021
VA5672	VA-154	V193	VO-19	V5848	VO-99	AFC1354	VCA-1104	AF1010	VCA-1161
VA5673	VA-230	V195	VO-118	V6127	VO-109	AFC1355	VCA-1135	AF1011	VCA-1167
VA5697	VA-239	V2167	VO-95	V6128	VO-104	AFC1356	VCA-1038	AF1014	VFAP-1643
VA5698	VA-251	V2222	VO-88	V6135	VO-110	AFC1359	VCA-1075	AF1016	VFA-1641
VA5699	VA-224	V241	VO-25	V6296	VO-114	AFC1366	VCA-1046	AF1026	VA-131
VA5701	VA-238	V2500	VO-88	V6311	VO-102	AFC1367	VCA-1138	AF1030	VA-135
VA5703	VA-233	V252	VO-15	V64	VO-15	AFC1368	VCA-1044	AF1031	VFAP-7908
VA5707	VA-203	V257	VO-15	V7662	VO-52	AFC1378	VCA-1041	AF1032	VA-260
VA5775	VA-241	V2821A	VO-40	V81	VO-95	AFC1388	VCA-1110	AF1033	VA-157
VA5779	VA-235	V288	VO-46	V85	VO-37	AFC1389	VCA-1113	AF1034	VA-153
VA5780	VA-252	V291	VO-27	V8812	LC-834	AFC1390	VCA-1089	AF1037	VA-117
VA5781	VA-202	V33	VO-108	HASTINGS		AFC1392	VCA-1039	AF1039	VA-118
VA5783	VA-211	V4006	VO-58	AFC1002	VCA-1157	AFC1399	VCA-1056	AF1040	VA-91
VA5786	VA-309	V4007	VO-58	AFC1004	VCA-1001	AFC1401	VCA-1167	AF1041	VA-144
VA5789	VA-278	V4011	VO-55	AFC1010	VCA-1161	AFC1412	VCA-1114	AF1044	VA-116
VA5792	VA-282	V4457	VO-25	AFC1057	VCA-1017	AFC1424	VCA-1053	AF1045	VA-410
VA5796	VA-323	V4459	VO-106	AFC1067	VCA-1008	AFC1428	VCA-1064	AF1047	VA-138
VA5798	VA-289	V4460	VO-106	AFC1110	VCA-1125	AFC1433	VCA-1108	AF1048	VA-129
VA5799	VA-234	V4466	VO-15	AFC1111	VCA-1163	AFC1447	VCA-1051	AF1048F	VA-129
VA5801	VA-374	V4476	VO-40	AFC1114	VCA-1003	AFC1457	VCA-1078C	AF1049	VA-148
VA5804	VA-353	V4477	VO-40	AFC1136	VCA-1002	AFC1458	VCA-1115	AF1052	VA-259

CAUTION: For general references only. Check catalog for correct filter application. Any use of this interchange to determine filter application is done at the installers risk.
 PRECAUCION: Solamente para referencias generales. Revise el catálogo para la correcta aplicación del filtro. Cualquier uso de la referencia cruzada para determinar la aplicación del filtro es riesgo del instalador. ATTENTION : Seulement pour les références d'ordre général. Contrôler l'application correcte du filtre avec le catalogue. Toute utilisation de moyens afin de déterminer l'application d'un filtre est faite aux risques de l'installateur.

Cross Reference

Table da equivalencias da fabricantes

Code de renvoi au fabricant

MFR'S NUMBER	REPLACEMENT NUMBER	MFR'S NUMBER	REPLACEMENT NUMBER	MFR'S NUMBER	REPLACEMENT NUMBER	MFR'S NUMBER	REPLACEMENT NUMBER	MFR'S NUMBER	REPLACEMENT NUMBER
HASTINGS		AF1164	VCA-1037	AF1290	VA-132	AF1384	VA-372	AF1523	VA-287
AF1055	VA-350	AF1165	VA-333	AF1291	VA-209	AF1385	VA-356	AF1527	VA-296
AF1056	VA-397	AF1166	VA-328	AF1294	VCA-1172	AF1386	VA-362	AF1528	VA-371
AF1057	VCA-1017	AF1167	VCA-1166	AF1295	VA-200	AF1387	VA-353	AF1530	VA-295
AF1061	VA-146	AF1198	VA-205	AF1296	VA-215	AF1394	VA-343	AF1531	VA-290
AF1062	VA-136	AF1203	VCA-1168	AF1297	VA-216	AF1395	VA-323	AF1538	VA-307
AF1063	VA-147	AF1204	VCA-1013	AF1298	VA-180	AF1397	VA-219	AF1539	VA-301
AF1064	VCA-1002	AF1205	VCA-1028	AF1299	VA-217	AF1398	VA-316	AF1544	VA-427
AF1067	VCA-1008	AF1206	VCA-1030	AF1300	VA-386	AF1399	VCA-1056	AF1545	VA-304
AF1070	VA-152	AF1207	VCA-1029	AF1301	VA-314	AF1400	VA-241	AF1546	VA-305
AF1071	VA-190	AF1208	VA-322	AF1302	VA-337	AF1402	VA-184	AF1547	VA-319
AF1072	VA-137	AF1210	VA-177	AF1303	VA-203	AF1403	VA-278	AF1548	VA-302
AF1074	VA-191	AF1211	VA-325	AF1304	VA-227	AF1405	VA-375	AF1551	VA-443
AF1075	VA-339	AF1212	VA-394	AF1305	VA-251	AF1406	VA-246	AF1555	VA-429
AF1077	VA-151	AF1213	VCA-1012	AF1307	VA-231	AF1410	VA-332	AF1556	VA-298
AF1078	VA-178	AF1214	VA-195	AF1308	VA-214	AF1414	VA-309	AF1557	VA-306
AF1079	VA-142	AF1215	VCA-1131	AF1309	VA-248	AF1415	VA-368	AF1558	VA-310
AF1080	VA-122	AF1216	VA-342	AF1310	VCA-1133	AF1417	VA-274	AF1559	VA-312
AF1081	VA-270	AF1218	VCA-1024	AF1311	VA-179	AF1418	VA-250	AF1560	VA-254
AF1082	VA-150	AF1219	VA-182	AF1312	VCA-1102	AF1422	VA-263	AF1561	VA-396
AF1083	VA-149	AF1220	VA-175	AF1313	VA-228	AF1423	VA-267	AF1562	VA-391
AF1084	VA-140	AF1223	VCA-1139	AF1314	VA-357	AF1426	VA-354	AF1563	VA-344
AF1085	VA-159	AF1225	VCA-1014	AF1315	VCA-1066	AF1429	VA-280	AF1564	VA-452
AF1086	VA-341	AF1226	VCA-1054	AF1316	VA-222	AF1430	VA-255	AF1566	VA-303
AF1093	VA-90	AF1227	VA-336	AF1317	VA-229	AF1431	VA-294	AF1567	VA-445
AF1101	VA-156	AF1229	VCA-1170	AF1318	VA-232	AF1434	VA-265	AF157	VA-403
AF1102	VA-193	AF1230	VCA-1124	AF1319	VA-154	AF1436	VA-315	AF1570	VA-446
AF1103	VA-154	AF1231	VCA-1074	AF1320	VA-318	AF1437	VA-266	AF1574	VA-442
AF1106	VA-345	AF1232	VA-247	AF1321	VA-204	AF1438	VA-268	AF1576	VA-457
AF1107	VA-172	AF1233	VA-380	AF1322	VA-237	AF1439	VA-275	AF1577	VA-424
AF1108	VA-155	AF1234	VA-380	AF1323	VA-202	AF1440	VA-202	AF1593	VA-435
AF1109	VA-169	AF1235	VCA-1068	AF1324	VA-226	AF1442	VA-257	AF1596	VA-311
AF1110	VCA-1125	AF1236	VCA-1122	AF1325	VA-213	AF1443	VA-317	AF1597	VA-326
AF1111	VCA-1163	AF1237	VCA-1096	AF1326	VA-264	AF1444	VA-364	AF1598	VA-280
AF1112	VA-149	AF1238	VCA-1060	AF1327	VA-360	AF1445	VA-366	AF1599	VA-393
AF1113	VA-170	AF1239	VCA-1065	AF1329	VA-212	AF1446	VA-245	AF160	VFAP-7912
AF1114	VCA-1003	AF1240	VA-206	AF1330	VA-289	AF1449	VA-384	AF1612	VA-318
AF1116	VA-166	AF1243	VA-188	AF1331	VA-224	AF145	VA-2	AF1614	VA-423
AF1119	VA-324	AF1244	VCA-1063	AF1332	VA-234	AF1450	VA-283	AF1619	VA-434
AF1121	VA-165	AF1245	VCA-1067	AF1333	VA-223	AF1452	VA-444	AF1620	VA-308
AF1122	VA-361	AF1246	VA-189	AF1335	VA-238	AF1453	VA-273	AF1623	VA-490
AF1125	VA-78	AF1249	VA-194	AF1336	VA-360	AF1454	VA-373	AF1627	VA-308
AF1126	VA-346	AF1250	VA-269	AF1337	VA-258	AF1455	VA-358	AF1630	VA-450
AF1127	VA-162	AF1251	VCA-1159	AF1338	VA-154	AF1456	VA-385	AF1637	VA-388
AF1128	VA-164	AF1252	VCA-1042	AF1339	VCA-1035	AF1459	VA-383	AF1640	VA-473
AF1129	VA-185	AF1254	VA-184	AF1343	VA-201	AF1463	VA-390	AF1642	VA-419
AF1130	VA-167	AF1255	VA-352	AF1344	VA-220	AF1464	VA-291	AF1645	VA-437
AF1132	VA-279	AF1256	VA-207	AF1345	VCA-1049	AF1470	VA-254	AF1655	VA-204
AF1133	VA-163	AF1257	VA-197	AF1346	VA-242	AF1475	VA-273	AF1660	VA-428
AF1134	VA-196	AF1258	VA-359	AF1347	VA-221	AF1479	VA-288	AF1663	VA-438
AF1135	VA-161	AF1260	VCA-1160	AF1348	VA-349	AF148	VFAP-7857	AF1666	VA-432
AF1136	VCA-1002	AF1261	VA-181	AF1352	VCA-1031	AF1481	VA-292	AF1672	VA-425
AF1137	VCA-1022	AF1264	VA-377	AF1357	VA-365	AF1482	VA-448	AF1674	VCA-1193
AF1138	VCA-1165	AF1265	VA-330	AF1358	VA-236	AF1483	VA-367	AF1676	VA-460
AF1139	VA-160	AF1267	VA-340	AF136	VA-105	AF1484	VA-296	AF1677	VA-371
AF1141	VA-347	AF1268	VA-208	AF1360	VA-233	AF1485	VA-285	AF1679	VA-430
AF1142	VA-132	AF1269	VA-199	AF1361	VA-243	AF1486	VA-284	AF1690	VA-449
AF1144	VA-335	AF1270	VA-355	AF1362	VA-235	AF1487	VA-253	AF1697	VA-456
AF1145	VCA-1040	AF1271	VCA-1070	AF1363	VA-240	AF1488	VA-293	AF1706	VA-260
AF1146	VCA-1012	AF1272	VCA-1063	AF1364	VA-447	AF1490	VA-286	AF1709	VA-417
AF1148	VCA-1020	AF1273	VA-186	AF137	VA-104	AF1491	VA-329	AF1710	VA-440
AF1151	VCA-1021	AF1274	VA-382	AF1373	VA-211	AF1492	VA-272	AF1711	VA-455
AF1154	VCA-1014	AF1276	VCA-1020	AF1374	VA-363	AF1495	VA-265	AF1716	VA-462
AF1155	VCA-1043	AF1276	VCA-1101	AF1375	VA-230	AF150	VA-106	AF1718	VA-471
AF1156	VA-183	AF1279	VCA-1155	AF1376	VA-374	AF1502	VA-300	AF1723	VCA-1179
AF1157	VCA-1164	AF1280	VA-198	AF1377	VA-225	AF1508	VA-297	AF1724	VCA-1188
AF1159	VA-270	AF1281	VA-249	AF1379	VA-244	AF1511	VA-334	AF1726	VA-463
AF1160	VA-192	AF1285	VA-210	AF1380	VA-252	AF1513	VCA-1103	AF190	VA-110
AF1161	VA-171	AF1286	VA-400	AF1381	VA-351	AF1514	VA-313	AF209	VA-109
AF1162	VA-184	AF1287	VA-379	AF1382	VA-282	AF1517	VA-426	AF213	VA-113
AF1163	VA-176	AF1288	VCA-1139	AF1383	VA-202	AF1519	VA-299	AF2314	VA-399

CAUTION: For general references only. Check catalog for correct filter application. Any use of this interchange to determine filter application is done at the installers risk.

PRECAUCION: Solamente para referencias generales. Revise el catálogo para la correcta aplicación del filtro. Cualquier uso de la referencia cruzada para determinar la aplicación del filtro es riesgo del instalador. ATTENTION : Seulement pour les références d'ordre général. Contrôler l'application correcte du filtre avec le catalogue. Toute utilisation de moyens afin de déterminer l'application d'un filtre est faite aux risques de l'installateur.

Cross Reference

Table da equivalencias da fabricantes

Code de renvoi au fabricant

MFR'S NUMBER	REPLACEMENT NUMBER	MFR'S NUMBER	REPLACEMENT NUMBER	MFR'S NUMBER	REPLACEMENT NUMBER	MFR'S NUMBER	REPLACEMENT NUMBER	MFR'S NUMBER	REPLACEMENT NUMBER
HASTINGS		AF981	VA-97	LF391	VO-35	LF593	VO-137	270A	VO-35
AF2318	VA-132	AF984	VA-98	LF393	VO-55	LF594	VO-80	HAVOLINE	
AF2397	VA-174	AF986	VA-99	LF396	VO-37	LF595	VO-128	TA-103	VA-414
AF2400	VA-218	AF987	VA-102	LF400	VO-40	LF604	VO-85	TA-109	VA-97
AF2402	VA-239	AF988	VA-124	LF402	VO-106	LF607	VO-84	TA-110	VA-416
AF2403	VA-381	AF990	VA-103	LF408	VO-64	LF608	VO-64	TA-111	VA-101
AF2404	VA-187	AF992	VA-108	LF410	VO-40	LF610	VO-85	TA-113	VA-107
AF243	VA-387	AF993	VFAP-7854	LF413	VO-40	LF611	VO-106	TA-114	VA-104
AF244	VFAP-7892	AF994	VA-93	LF423	VO-95	LF612	VO-88	TA-115	VA-99
AF258	VFAP-7859	CB23	VA-34	LF441	VO-46	LF613	VO-88	TA-116	VA-106
AF291	VFAP-7859	CB24	VA-48	LF456	VO-146	LF615	VO-90	TA-118	VA-102
AF295	VA-401	GF111	VG-14	LF461	VO-106	LF618	VO-87	TA-119	VA-103
AF3	VA-38	GF115	VG-16	LF462	VO-60	LF623	VO-88	TA-122	VA-98
AF307	VA-89	GF246	VG-30	LF465	VO-143	LF624	VO-76	TA-125	VFAP-7857
AF326	VA-338	GF247	VG-32	LF470	VO-1	LF625	VO-96	TA-126	VA-110
AF361	VA-125	GF258	VG-33	LF477	VO-93	LF627	VO-97	TA-127	VA-109
AF377	VA-321	GF27	VG-2	LF479	VO-150	LF628	VO-129	TA-128	VFAP-7892
AF383	VA-128	HF1000	VO-25	LF481	VO-74	LF629	VO-92	TA-129	VA-113
AF385	VA-412	HF928	VO-163	LF482	LC-8170	LF630	VO-200	TA-131	VA-89
AF387	VA-132	HF929	VO-52	LF483	VO-118	LF631	VO-111	TA-132	VA-89
AF389	VA-395	LF104	VO-86	LF484	VO-106	LF634	VO-91	TA-133	VFAP-7859
AF390	VA-205	LF105	VO-86	LF486	VO-106	LF636	VO-88	TA-134	VA-92
AF391	VA-112	LF107	VO-95	LF487	VO-108	LF637	VO-88	TA-135	VA-112
AF4	VA-321	LF110	VO-88	LF489	VO-67	LF639	VO-101	TA-136	VA-94
AF411	VFAP-7893	LF113	VO-106	LF490	VO-95	LF640	VO-102	TA-137	VA-93
AF412	VFAP-7865	LF114	VO-144	LF491	VO-106	LF641	VO-88	TA-140	VFAP-1612
AF417	VA-114	LF115	VO-1	LF492	VO-15	LF642	VO-99	TA-141	VFAP-7908
AF431	VFAP-7912	LF116	VO-70	LF493	VO-15	LF643	VO-98	TA-142	VA-125
AF439	VA-120	LF120	VO-62	LF494	VO-25	LF646	VO-112	TA-143	VA-135
AF441	VA-411	LF134	VO-118	LF505	VO-162	LF647	VO-1	TA-144	VA-260
AF445	VA-111	LF142	VO-95	LF507	VO-161	LF648	VO-52	TA-145	VFAP-1643
AF463	VFAP-1612	LF143	VO-19	LF508	VO-64	LF649	VO-106	TA-146	VA-91
AF481	VFAP-1613	LF144	VO-19	LF509	VO-65	LF651	VO-104	TA-147	VFAP-917
AF484	VA-94	LF145	VO-27	LF510	VO-86	LF652	VO-122	TA-148	VA-117
AF509	VA-404	LF147	VO-136	LF511	VO-76	LF653	VO-109	TA-150	VFA-1641
AF513	VA-92	LF148	VO-52	LF512	VO-73	LF654	VO-109	TA-151	VA-320
AF521	VA-320	LF15	VO-1	LF514	LC-8445	LF655	VO-25	TA-152	VA-259
AF724	VA-411	LF157	VO-25	LF517	VO-15	LF656	VO-110	TA-153	VA-116
AF77	VA-402	LF164	VO-108	LF518	VO-1	LF659	VO-138	TA-154	VA-118
AF805	VA-69	LF167	LC-833	LF519	VO-127	LF660	VO-103	TA-155	VA-412
AF809	VA-45	LF194	VO-106	LF520	VO-95	LF661	VO-141	TA-156	VA-410
AF826	VA-38	LF196	VO-95	LF521	VO-15	LF665	VO-131	TA-157	VA-122
AF838	VA-44	LF211	VO-134	LF522	VO-66	LF665	VO-25	TA-158	VA-120
AF842	VA-40	LF212	VO-108	LF523	VO-106	LF668	VO-140	TA-159	VA-140
AF868	VA-85	LF222	VO-108	LF524	VO-75	LF669	VO-116	TA-160	VA-78
AF873	VA-65	LF224	VO-56	LF525	VO-25	LF671	VO-106	TA-161	VA-149
AF878	VA-205	LF225	VO-65	LF529	VO-71	LF674	VO-132	TA-162	VA-111
AF879	VA-413	LF230	VO-108	LF530	VO-69	LF684	VO-161	TA-163	VA-129
AF880	VA-66	LF232	VO-58	LF534	VO-162	LF686	VO-96	TA-164	VA-137
AF882	VA-86	LF233	VO-16	LF538	VO-163	LF687	VO-25	TA-165	VA-150
AF892	VFAP-917	LF238	VO-15	LF542	VO-106	LF690	VO-133	TA-166	VA-124
AF894	VA-408	LF239	VO-52	LF543	VO-19	LF694	VO-149	TA-167	VA-138
AF895	VA-84	LF240	VO-106	LF546	VO-143	LF696	VO-142	TA-168	VA-114
AF897	VA-70	LF242	VO-52	LF547	VO-106	LF697	VO-114	TA-169	VA-146
AF899	VA-90	LF270	VO-35	LF548	VO-76	LF698	VO-153	TA-170	VA-151
AF911	VA-38	LF279	VO-56	LF549	VO-119	LF700	VO-121	TA-171	VA-154
AF920	VA-414	LF280	VO-15	LF550	VO-25	LF707	VO-95	TA-172	VA-165
AF925	VA-84	LF281	VO-162	LF553	VO-77	LF710	VO-95	TA-173	VFAP-7893
AF931	VA-389	LF299	VO-63	LF556	VO-124	LF712	VO-106	TA-174	VA-136
AF951	VA-88	LF301	LC-834	LF558	VO-81	LF713	VO-95	TA-175	VA-156
AF953	VA-78	LF304	VO-95	LF560	VO-82	LF714	VO-136	TA-176	VA-152
AF954	VA-269	LF308	VO-40	LF561	VO-78	LF721	VO-123	TA-177	VA-193
AF958	VA-416	LF339	VO-40	LF563	VO-25	LF722	VO-117	TA-178	VA-170
AF971	VA-158	LF344	VO-1	LF565	VO-106	LF725	VO-139	TA-179	VA-155
AF972	VA-261	LF362	VO-95	LF566	VO-94	LF728	VO-106	TA-180	VA-162
AF973	VA-408	LF379	VO-95	LF568	VO-69	LF732	VO-115	TA-181	VA-167
AF975	VA-370	LF383	VO-19	LF576	VO-25	LF733	VO-167	TA-182	VA-144
AF976	VA-83	LF384	VO-40	LF577	VO-150	LF738	VO-162	TA-183	VA-178
AF977	VA-96	LF385	VO-25	LF585	VO-106	LF744	VO-164	TA-184	VA-164
AF979	VA-101	LF386	VO-106	LF586	VO-135	LF746	VO-165	TA-185	VA-166
AF98	VA-107	LF387	VO-15	LF589	VO-25	LF748	VO-170	TA-186	VA-163

CAUTION: For general references only. Check catalog for correct filter application. Any use of this interchange to determine filter application is done at the installers risk.

PRECAUCION: Solamente para referencias generales. Revise el catálogo para la correcta aplicación del filtro. Cualquier uso de la referencia cruzada para determinar la aplicación del filtro es riesgo del instalador. ATTENTION : Seulement pour les références d'ordre général. Contrôler l'application correcte du filtre avec le catalogue. Toute utilisation de moyens afin de déterminer l'application d'un filtre est faite aux risques de l'installateur.

Cross Reference

Table da equivalencias da fabricantes

Code de renvoi au fabricant

MFR'S NUMBER	REPLACEMENT NUMBER	MFR'S NUMBER	REPLACEMENT NUMBER	MFR'S NUMBER	REPLACEMENT NUMBER	MFR'S NUMBER	REPLACEMENT NUMBER	MFR'S NUMBER	REPLACEMENT NUMBER
HAVOLINE		TA-259	VA-254	T-56	VO-93	E206L	VA-157	E647L	VA-329
TA-187	VA-161	TA-26	VA-2	T-57	VO-81	E207HD221	VO-151	E650H	VO-98
TA-188	VA-160	TA-260	VA-266	T-59	VO-80	E217H	VO-174	E650H D233	VO-98
TA-189	VA-157	TA-261	VA-283	T-60	VO-150	E217H D310	VO-174	E657L	VA-149
TA-190	VA-270	TA-262	VA-265	T-61	VO-84	E237H	VO-168	E660L	VA-347
TA-191	VA-183	TA-27	VA-403	T-62	VO-88	E237H D331	VO-168	E662L	VA-318
TA-192	VA-184	TA-38	VA-402	T-63	VO-87	E240L	VA-380	E670L	VA-329
TA-193	VA-322	TA-46	VA-40	T-64	VO-96	E27HD125	VO-85	E675LD157	VA-448
TA-194	VA-175	TA-48	VA-44	T-65	VO-90	E27HD84	VO-85	E676L01	VA-313
TA-195	VA-342	TA-49	VA-38	T-66	VO-102	E28H01D26	VO-140	E678L	VA-128
TA-198	VA-190	TA-65	VA-65	T-67	VO-88	E2907LI	VCA-1139	E682L	VFAP-1613
TA-199	VA-196	TA-67	VA-66	T-68	VO-81	E2908LI	VCA-1160	E690L	VA-363
TA-200	VA-171	TA-68	VA-413	T-69	VO-85	E2910LI	VCA-1134	E701L	VA-365
TA-201	VA-142	TA-71	VA-85	T-70	VO-91	E2915LC	VCA-1133	E701L01	VA-365
TA-202	VA-169	TA-72	VA-70	T-71	VO-110	E2916LI	VCA-1142	E708L	VA-178
TA-203	VA-182	TA-73	VA-269	T-72	VO-104	E2920LI-2	VCA-1041	E709L	VA-346
TA-204	VA-132	TA-77	VA-205	T-73	VO-99	E2930LI	VCA-1042	E71HD141	VO-129
TA-205	VA-176	TA-78	VA-78	T-74	VO-109	E2945LI	VCA-1031	E720L	VA-337
TA-206	VA-192	TA-79	VA-90	HENGST		E2948LI	VCA-1194	E728L	VA-364
TA-207	VA-197	TA-80	VA-88	D21E142H	VO-62	E2954LC	VCA-1153	E730L	VFAP-7859
TA-208	VA-179	TA-82	VA-84	E1001H	VO-150	E2954LC01	VCA-1153	E732L	VA-204
TA-209	VA-180	TA-83	VA-83	E1001HD28	VO-150	E2956LI	VCA-1036	E748L	VA-340
TA-210	VA-195	TA-85	VA-96	E1011L	VA-254	E2962LI	VCA-1078	E751L	VA-170
TA-211	VA-203	TA-86	VA-408	E1015L	VA-435	E2964LI	VCA-1177	E756L	VA-144
TA-212	VA-177	TA-87	VA-108	E1025L	VA-296	E2981LI	VCA-1146	E762L	VA-103
TA-213	VA-215	TA-88	VA-105	E1031L-2	VA-371	E2998LI	VCA-1189	E771L	VA-83
TA-214	VA-201	TA-9	VA-321	E104HD43	LC-8445	E2998LI	VCA-1189	E772L	VA-387
TA-215	VA-202	TFC-502	VO-15	E1040L	VA-442	E30HD51	VO-120	E793L	VA-137
TA-216	VA-212	TFC-504	VO-95	E1058L	VA-443	E300HD28	VO-144	E813HD188	VO-138
TA-217	VA-231	TFC-516	VO-27	E106HD171	VO-97	E301L	VA-138	E818H D238	VO-164
TA-218	VA-224	TFC-517	VO-19	E106HD34	LC-8170	E31HD93	VO-82	E819L	VA-166
TA-219	VA-216	TFC-518	VO-15	E1075L	VA-449	E32H	VO-92	E82HD24	VO-130
TA-220	VA-200	TFC-520	VO-106	E1079L	VA-450	E32HD125	VO-92	E821L	VA-349
TA-221	VA-214	TFC-521	VO-106	E1090L	VA-453	E32HD184	VO-92	E851L	VA-326
TA-222	VA-154	TFC-521	VO-106	E11HD155	VO-103	E33L	VA-69	E852L	VA-367
TA-223	VA-241	TFC-524	VO-25	E11HD50	VO-69	E340HD247	VO-165	E859H	VO-169
TA-224	VA-209	TFC-525	VO-40	E11HD57	VO-69	E355HD58	VO-94	E859H D352	VO-169
TA-225	VA-238	TFC-528	VO-60	E11HD99	VO-69	E355H01D109	VO-94	E864H	VO-92
TA-226	VA-225	TFC-533	VO-15	E11H01D50	VO-69	E355H01D58	VO-94	E88HD24	LC-833
TA-227	VFAP-7865	TFC-534	VO-106	E11H02D155	VO-103	E356HD56	VO-150	E880L	VA-86
TA-228	VA-174	TFC-538	VO-106	E110HD24	LC-834	E358H	VO-117	E881L	VA-150
TA-229	VA-198	T-1-FS	VO-1	E115HD208	VO-132	E358HD246	VO-117	E883L	VA-152
TA-230	VA-251	T-16	VO-108	E115H01D208	VO-132	E359HD06	VO-131	E884L	VA-314
TA-231	VA-233	T-18	VO-65	E1155L	VA-257	E3903LI	VCA-1175	E887L	VA-373
TA-232	VA-207	T-23	VO-108	E1235L	VA-292	E3929LI	VCA-1061	E895L	VA-231
TA-233	VA-269	T-26	VO-16	E124H01 D202	VO-153	E399L	VA-325	E900LI	VCA-1026
TA-234	VA-186	T-27	VO-55	E1256L	VA-99	E3995LI	VCA-1073	E904LI	VCA-1029
TA-235	VA-252	T-28	VO-118	E1259L	VA-232	E409L	VA-341	E920LC	VCA-1161
TA-236	VA-223	T-29	VO-25	E1286L	VA-234	E414L	VA-199	E955LI	VCA-1124
TA-237	VA-221	T-32	VO-37	E14HD77	VO-127	E418L	VA-333	E968LI	VCA-1157
TA-238	VA-229	T-33	VO-35	E142HD21	VO-62	E44HD110	VO-111	E970LC	VCA-1106
TA-239	VA-333	T-35	VO-95	E15HD58	VO-66	E462L	VA-350	E977LC	VCA-1162
TA-240	VA-226	T-36	VO-88	E154H	VO-71	E488L	VA-274	E977LI	VCA-1162
TA-241	VA-218	T-37	VO-46	E154HD48	VO-71	E488L01	VA-274	H10W	VO-95
TA-242	VA-217	T-38	VO-56	E161L	VA-157	E550L	VA-84	H10W01	VO-95
TA-243	VA-206	T-39	VO-63	E17HD57	VO-137	E551L	VA-397	H10W04	VO-19
TA-244	VA-228	T-41	VO-58	E173L	VFAP-7865	E552L	VA-414	H10W04	VO-35
TA-245	VA-188	T-42	VO-118	E175L	VA-124	E555L	VFAP-7908	H10W05	VO-95
TA-246	VA-208	T-43	VO-108	E175L01	VFAP-7865	E581L	VA-105	H10W15	VO-95
TA-247	VA-213	T-44	VO-67	E19HD83	VO-77	E597L	VA-355	H10W18	VO-88
TA-248	VA-244	T-45	VO-65	E1959LC	VCA-1103	E61H D127	VO-91	H10W22	VO-95
TA-249	VA-258	T-46	VO-73	E1959LI	VCA-1103	E611H	VO-98	H13W01	VO-106
TA-250	VA-232	T-47	VO-64	E1990LI	VCA-1172	E611HD122	VO-98	H14W04	VO-15
TA-251	VA-248	T-48	VO-106	E1998LC	VCA-1147	E614H	VO-98	H14W06	VO-15
TA-252	VA-237	T-49	VO-75	E202HD34	VO-74	E614H D256	VO-98	H14W07	VO-15
TA-253	VA-264	T-50	VO-66	E202H01D34	VO-74	E621H	VO-78	H14W08	VO-55
TA-254	VA-202	T-51	VO-76	E203HD67	VO-128	E622H D145	VO-67	H14W10	VO-118
TA-255	VA-245	T-52	LC-8170	E203H03	VO-112	E622HD145	VO-67	H14W10	VO-15
TA-256	VA-294	T-53	VO-150	E203H03D67	VO-112	E627L	VA-371	H14W22	VO-143
TA-257	VA-255	T-54	VO-69	E203H04 D67	VO-112	E630H	VO-76	H14W27	VO-15
TA-258	VA-268	T-55	VO-86	E203H04D67	VO-112	E640L	VA-171	H14W30	VO-101

CAUTION: For general references only. Check catalog for correct filter application. Any use of this interchange to determine filter application is done at the installers risk.

PRECAUCION: Solamente para referencias generales. Revise el catálogo para la correcta aplicación del filtro. Cualquier uso de la referencia cruzada para determinar la aplicación del filtro es riesgo del instalador. ATTENTION : Seulement pour les références d'ordre général. Contrôler l'application correcte du filtre avec le catalogue. Toute utilisation de moyens afin de déterminer l'application d'un filtre est faite aux risques de l'installateur.

Cross Reference

Table da equivalencias da fabricantes

Code de renvoi au fabricant

MFR'S NUMBER	REPLACEMENT NUMBER	MFR'S NUMBER	REPLACEMENT NUMBER	MFR'S NUMBER	REPLACEMENT NUMBER	MFR'S NUMBER	REPLACEMENT NUMBER	MFR'S NUMBER	REPLACEMENT NUMBER
HENGST		15400-PME-T01	VO-106	17220-RDA-A10	VA-351	89443-041-11	VO-106	2811323100	VA-131
H14/2W	VO-15	15400-PR3-003	VO-106	17220-RDJ-J00	VA-192	HYUNDAI		2811326000	VA-172
H16W02	VO-15	15400-PR3-004	VO-106	17220-REZ-A00	VA-275	C2H79AP000	VCA-1181	2811326350	VA-359
H17W02	VO-1	15400-PR3-005	VO-106	17220-RGL-A00	VA-202	D3H79-AK000	VCA-1190	2811333100	VA-372
H17W05	VO-15	15400-PR3-014	VO-106	17220-RGL-A10	VA-202	F2H79-AK000	VCA-1191	281133K010	VA-228
H17W20	VO-155	15400-PR3-305	VO-106	17220-RGW-A00	VA-202	XJAU00153	VO-106	281133K050	VA-265
H17W29	VO-170	15400-PR3-405	VO-106	17220-RJE-A00	VA-210	XJBR00921	VO-95	281133K200	VA-227
H19W06	VO-15	15400-PR3-406	VO-106	17220-RJE-A10	VA-210	087902E200A	VCA-1047	281133M000	VA-383
H19W08	VO-64	15400-PT7-005	VO-106	17220-RK2-A00	VA-220	087902E250A	VCA-1057	281133M100	VA-358
H20W01	VO-16	15400-POH-305	VO-106	17220-RL5-A00	VA-294	087902G000A	VCA-1072	281133X000	VA-334
H20W05	VO-19	15400-POH-305PE	VO-106	17220-RMX-000	VA-343	087902H000A	VCA-1051	2811335500	VA-128
H20W08	VO-25	15400-RAF-T01	VO-106	17220-RNA-A00	VA-212	087902H000A	VCA-1051	2811337101	VA-152
H205W01	VO-15	15400-RTA-003	VO-106	17220-RNO-A00	VA-202	087903D000A	VCA-1139	2811339000	VA-345
H209W	VO-136	15400-RTA-004	VO-106	17220-RRA-A00	VA-237	087903J000A	VCA-1144	281134V100	VA-334
H216W	VO-162	15400-R5G-A01	VO-106	17220-RV0-A00	VA-291	087903J100A	VCA-1144	3SF79AQ000	VCA-1075
H24W01	VO-159	15400-ZJL-004	VO-106	17220-RWC-A00	VA-357	087903K000A	VCA-1035	97133C2000	VCA-1181
H24W04	VO-95	15400-ZJ1-004	VO-106	17220-RWC-A01	VA-357	087903M000A	VCA-1062	97133-D1000	VCA-1190
H25W01	VO-56	15400-ZW4-003	VO-106	17220-RX0-A00	VA-297	087903SAA0	VCA-1075	97133-F2000	VCA-1191
H318W	VO-123	15400-111-003	VO-106	17220-RYE-A00	VA-202	0879038100A	VCA-1139	97133F2000	VCA-1191
H833HD321	VO-166	15400-611-003	VO-106	17220-RYE-A01	VA-202	11E170120	VO-64	97133-J9000	VCA-1190
H90W03	VO-16	15400-679-003	VO-106	17220-RYE-A10	VA-390	11E170140	VO-64	97133I000	VCA-1138
H90W12	VO-25	15400-679-004	VO-106	17220-RZA-000	VA-252	2BF79-AQ000	VCA-1071	97133D000	VCA-1066
H90W13	VO-52	15400-679-005	VO-106	17220-R1A-A01	VA-292	2SF79AQ000	VCA-1047	97133ZD100	VCA-1066
H90W19	VO-25	15400-679-023	VO-106	17220-R40-A00	VA-221	2630002500	VO-106	97133E200	VCA-1047
H90W20	VO-25	15400-689-003	VO-27	17220-R5A-A00	VA-307	2630002502	VO-106	97133E250	VCA-1057
H90W23	VO-52	15400-689-004	VO-27	17220-R70-A00	VA-220	2630021A00	VO-106	97133ZG000	VCA-1072
H90W25	VO-106	15410-MB0-003	VO-106	17220-R8A-A01	VA-393	2630021010	VO-106	97133ZH000	VCA-1051
H90W27	VO-25	15410-MB3-003	VO-106	17220-5AA-A00	VA-464	2630029000	VO-52	97133ZH001	VCA-1051
H90W29	VO-124	15410-MFJ-D01	VO-106	17220-5A2-A00	VA-304	26300-33504	VO-106	97133-3D000	VCA-1190
H96W03	VO-146	15410-MJ0-003	VO-106	17220-5BA-A00	VA-454	2630035A00	VO-106	971333J000	VCA-1144
H97W01	VO-40	15410-MJ0-004	VO-106	17220-5G0-A00	VA-305	2630035014	VO-106	97133-3J100	VCA-1144
H97W02	VO-106	15410-MJ0-405	VO-106	17220-5J6-A00	VA-419	2630035054	VO-106	97133-3K000	VCA-1035
H97W05	VO-106	15410-ZJA-99AH	VO-106	17220-5J6-A10	VA-456	2630035056	VO-106	971333K000	VCA-1035
H97W06	VO-106	17220-PAA-A00	VA-117	17220-5LA-A00	VA-431	2630035500	VO-106	971333K000A	VCA-1035
H97W07	VO-40	17220-PGE-A00	VA-361	17220-5R0-008	VA-432	2630035501	VO-106	971333M000	VCA-1062
H97W08	VO-106	17220-PGK-A00	VA-192	17220-5R0-008	VA-432	2630035502	VO-106	971333SAA0	VCA-1075
H97W09	VO-106	17220-PJ2-003	VA-135	17220-51B-H00	VA-466	2630035503	VO-106	976171C000	VCA-1054
H97W10	VO-147	17220-PLC-000	VA-165	17220-6A0-A00	VA-497	2630042010	VO-136	976191C000	VCA-1054
H97W11	VO-106	17220-PMR-A00	VA-165	17315-SNL-A01	VA-242	2630042030	VO-157	976193D000	VCA-1139
H97W13	VO-40	17220-PM4-A00	VA-165	79371-SZ3-A01	VCA-1060	2630042040	VO-157	976193D100	VCA-1139
H97W16	VO-147	17220-PNA-003	VA-196	80290-FT3-E01	VCA-1122	2630042060	VO-157	976193D200	VCA-1139
W17W18	VO-15	17220-PNB-003	VA-196	80290-SOX-A01	VCA-1013	26320-3CAA0	VO-109	9761938000	VCA-1139
HONDA		17220-PO7-000	VA-103	80290-ST3-E01	VCA-1122	263203CAA0	VO-109	9761938100	VCA-1139
13400-PH1-004	VO-106	17220-PT2-000	VA-83	80290-SOX-A01	VCA-1013	263203CKB0	VO-167	ISUZU	
15400-PA6-003	VO-27	17220-PWA-J10	VA-242	80291-SAA-J01	VCA-1110	263203C100	VO-90	CFS1215	VO-162
15400-PA6-004	VO-27	17220-PZA-A00	VA-328	80291-S84-A01	VCA-1167	263203C250	VO-99	H132011	VO-95
15400-PA6-010	VO-27	17220-PZD-A00	VA-196	80291S84A010M1	VCA-1167	26320-3C30A	VO-99	M38165	VO-19
15400-PA6-305	VO-27	17220-P0A-A00	VA-113	80291-TBA-A11	VCA-1061	263203C30A	VO-99	X1320002	VO-1
15400-PA6-405	VO-27	17220-P07-T00	VA-103	80291-TF0-E01	VCA-1061	263203C700	VO-99	X13201001	VO-95
15400-PA6-506	VO-27	17220-P07-000	VA-103	80291-TF3-E01	VCA-1061	263203F100	VO-99	X13201002	VO-1
15400-PCX-004	VO-106	17220-P1K-E00	VA-103	80291-TGQ001	VCA-1061	28113-C1100	VA-417	X13201008	VO-163
15400-PC6-003	VO-106	17220-P2A-000	VA-328	80291-T5R-A01	VCA-1061	28113-D3300	VA-458	X13201009	VO-25
15400-PC6-004	VO-106	17220-P2A-005	VFAP-7908	80292-FDA-A01	VCA-1063	28113-F2000	VA-465	ZAB1	VO-15
15400-PFB-004	VO-106	17220-P2C-Y01	VFAP-7908	80292-SCA-E11	VCA-1012	28113F2000	VA-465	1132004870	VO-163
15400-PFB-014	VO-106	17220-P2F-A01	VFAP-7908	80292-SCV-A01	VCA-1012	2811308000	VA-208	1132004871	VO-163
15400-PH1-F02	VO-106	17220-P2J-003	VA-135	80292-SDA-A01	VCA-1063	281131G000	VA-201	1132004872	VO-163
15400-PH1-003	VO-106	17220-P2N-A00	VA-135	80292-SDA-407	VCA-1063	28113-1J000	VA-268	1132400460	VO-162
15400-PH1-004	VO-106	17220-P2P-A01	VA-135	80292-SFC-A01	VCA-1063	28113-1P000	VA-268	1132400461	VO-162
15400-PH1-014	VO-106	17220-P45-G00	VA-83	80292-SHJ-A41	VCA-1063	281131R100	VA-300	1132400462	VO-162
15400-PH9-004	VO-106	17220-P5A-000	VA-148	80292-SHJ-A42	VCA-1063	281132B000	VA-240	1132400471	VO-163
15400-PK1-003	VO-106	17220-P72-000	VA-338	80292-SWA-A01	VCA-1063	281132D000	VA-193	1132400473	VO-163
15400-PLC-004	VO-106	17220-P8C-A00	VA-118	80292-S5A-003	VCA-1012	281132H000	VA-235	1132400602	VO-163
15400-PLG-003	VO-106	17220-P8F-A00	VA-270	80292-S5D-A01	VCA-1012	281132M010	VA-378	1132400620	VO-162
15400-PLM-A0PLE	VO-106	17220-P8F-A10	VA-270	80292-S6D-A01	VCA-1012	281132M200	VA-392	1132400621	VO-162
15400-PLM-A01	VO-106	17220-RAA-A00	VA-183	80292-TBA-A11	VCA-1061	281132M300	VA-331	1132400622	VO-162
15400-PLM-A01PE	VO-106	17220-RBB-A00	VA-183	80292-TF0-G01	VCA-1061	281132P000	VA-265	1132400750	VO-162
15400-PLM-A02	VO-106	17220-RB0-000	VA-366	80292-TV1-E01	VCA-1063	281132P100	VA-265	1132401220	VO-163
15400-PL2-004	VO-60	17220-RB0-000	VA-250	80292-TZ3-A41	VCA-1063	281132S000	VA-283	1132401600	VO-163
15400-PL2-015	VO-60	17220-RCA-A00	VA-184	80292-TZ5-A41	VCA-1063	28113-2W100	VA-311	1132401601	VO-163
15400-PL2-305	VO-60	17220-RCJ-A00	VA-184	80292-T0G-A01	VCA-1063	2811322600	VA-166	1132401681	VO-163
15400-PL2-315	VO-60	17220-RDA-A00	VA-184	89443-041-10	VO-106	2811323001	VA-131	1132404870	VO-163

CAUTION: For general references only. Check catalog for correct filter application. Any use of this interchange to determine filter application is done at the installers risk.
 PRECAUCION: Solamente para referencias generales. Revise el catálogo para la correcta aplicación del filtro. Cualquier uso de la referencia cruzada para determinar la aplicación del filtro es riesgo del instalador. ATTENTION : Seulement pour les références d'ordre général. Contrôler l'application correcte du filtre avec le catalogue. Toute utilisation de moyens afin de déterminer l'application d'un filtre est faite aux risques de l'installateur.

Cross Reference

Table da equivalencias da fabricantes

Code de renvoi au fabricant

MFR'S NUMBER	REPLACEMENT NUMBER	MFR'S NUMBER	REPLACEMENT NUMBER	MFR'S NUMBER	REPLACEMENT NUMBER	MFR'S NUMBER	REPLACEMENT NUMBER	MFR'S NUMBER	REPLACEMENT NUMBER
ISUZU		8251685940	VG-14	8972093060	VO-106	E-1008	VA-169	VF1013	VCA-1110
13200487	VO-163	8251713770	VO-55	8972149830	VO-75	E-1009	VA-161	VF1014	VCA-1187
132004870	VO-163	8742019423	VO-19	8972149831	VO-75	E-1015	VA-44	VF1016	VCA-1093
13201	VO-15	8889842150	VO-58	8972149833	VO-75	E-1025	VA-44	VF1017	VCA-1179
132011	VO-40	8890173420	VO-108	8972149834	VO-75	E-1065	VA-38	VF2001	VCA-1063
132011	VO-95	8890175240	VO-88	8973713340	VO-161	E-1100	VA-321	VF2003	VCA-1028
132012	VO-1	8913240093	VO-15	897371337	VO-162	E-1150	VA-402	VF2005	VCA-1037
13202	VO-15	8917482800	VO-162	9132400880	VO-25	E-1500	VA-2	VF2006	VCA-1065
132022	VO-1	8931562980	VO-16	913240093	VO-15	E-1796	VA-92	VF2007	VCA-1047
13240017	VO-15	8931563000	VO-16	9132400930	VO-15	E-1986	VA-169	VF2008	VCA-1067
132400461	VO-162	8931567500	VO-52	9132408040	VO-15	E-1990	VA-246	VF2009	VCA-1042
13240080	VO-95	8941010210	VO-106	9132408041	VO-15	E-1998	VA-290	VF2010	VCA-1072
13240093	VO-15	8941226120	VA-86	9142151260	VA-321	E-2296	VA-171	VF2012	VCA-1166
132400930	VO-15	894132678	VA-86	9142151330	VA-86	E-2429	VA-196	VF2014	VCA-1066
132401610	VO-163	8941326780	VA-86	94037791	VO-163	E-2919	VA-375	VF2016	VCA-1075
15208AA000	VO-25	8941357470	VO-106	94243270	VO-35	E-2993	VA-288	VF2018	VCA-1070
15208AA001	VO-25	8941357471	VO-106	97148270	VO-161	E-3260	VA-2	VF2019	VCA-1049
15208AA030	VO-106	8941461550	VO-37	97719921	VO-162	E-9233	VA-97	VF2022	VCA-1012
15208W3403	VO-15	8941494180	VO-106	97779876	VO-162	E-9282	VA-329	VF2026	VCA-1071
15400PR3004	VO-106	8941516143	VA-86	97780138	VO-161	HP-1001	VO-16	VF2033	VCA-1061
16546AA020	VA-86	8941697780	VO-95	97780139	VO-163	HP-1002	VO-25	VF2037	VCA-1051
1873100700	VO-163	8941697781	VO-95	994156455	VO-35	HP-1003	VO-40	VF2040	VCA-1078C
1878116380	VO-162	8941697782	VO-95	JAGUAR		HP-1004	VO-106	VF2041	VCA-1059
2080101041	VO-25	8942004870	VO-106	AJ82297	VO-86	HP-1005	VO-19	VF2042	VCA-1050
2080101131	VO-15	8942019420	VO-106	CBC7083	VG-14	HP-1007	VO-58	VF2044	VCA-1173
2080101141	VO-25	8942019422	VO-106	C2C35417	VG-14	HP-1008	VO-106	VF2046	VCA-1164
2250106330	VO-58	8942019423	VO-19	C2C41611	VO-86	HP-1008	VO-106	VF2047	VCA-1189
2906546000	VO-162	8942088630	VO-146	C2C4163	VG-14	HP-1009	VO-95	VF2049	VCA-1185
2906548000	VO-161	8942172720	VO-35	C2D3670	VO-141	HP-1010	VO-106	VF2050	VCA-1174
2906548100	VO-161	8942172721	VO-35	C2N3587	VO-86	HP-1011	VO-65	VF2053	VCA-1186
2906548400	VO-162	8942208332	VO-35	C2S11215	VA-363	HP-1012	VO-118	VF3001	VCA-1022
294456641	VO-106	8942416271	VO-35	C2S4163	VG-14	HP-1014	VO-86	VF3004	VCA-1013
2944566410	VO-106	8942432700	VO-19	C2Z21964	VO-25	HP-1014	VO-86	VF3005	VCA-1168
2945610000	VO-161	8942432701	VO-15	C42797	VO-86	HP-1015	VO-106	VF3007	VCA-2033
2945611000	VO-163	8942435020	VO-19	EAC1467	VO-86	HP-1016	VO-60	VF3012	VCA-1073
2945611070	VO-56	8942435021	VO-19	EAZ1354	VO-86	HP-1017	VO-152	VF3013	VCA-1135
2945611080	VO-58	8943381810	VO-161	EBC10303	VO-86	HP-1017	VO-160	VF3017	VCA-1076
2945611090	VO-88	8943381811	VO-161	EBC9658	VO-86	HP-1017	VO-200	33-2002	VA-69
2945611120	VO-162	8943687270	VO-106	JM0000010	VCA-1156	HP-1017	VO-88	33-2006	VA-40
5132400410	VO-25	8943763530	VA-96	NCE1708BA	VO-86	HP-2001	VO-55	33-2012	VA-205
5850001800	VO-106	8943763550	VA-401	NJA3558AA	VA-394	HP-2002	VO-65	33-2014	VFAP-917
5860001790	VO-106	8944128150	VO-106	NMD6091AC	VG-14	HP-2003	VO-108	33-2015	VA-413
5860082900	VO-106	894428310	VO-35	NNA6091AA	VG-14	HP-2004	VO-95	33-2018	VA-90
5861024060	VO-25	8944304110	VO-106	XR817215	VO-118	HP-2005	VO-15	33-2022	VA-65
5861024090	VO-15	8944304111	VO-106	XR823395	VO-118	HP-2006	VO-108	33-2023	VA-70
5861171220	VO-25	8944304112	VO-106	XR830254	VCA-1131	HP-2007	VO-35	33-2024	VA-66
5862022000	VO-106	8944432560	VO-35	XR830418	VA-142	HP-2008	VO-25	33-2030	VA-84
5862022550	VA-113	8944456560	VA-408	XR83332	VO-118	HP-2009	VO-118	33-2031-2	VA-86
5864015150	VO-106	8944558380	VA-86	XR849205	VCA-1131	HP-2010	VO-88	33-2033	VA-88
5873103370	VO-35	8944567410	VO-106	XR88237	VA-142	HP-2010	VO-88	33-2034	VA-416
5873104420	VO-35	8944567411	VO-106	1X439601AA	VA-363	HP-2011	VO-201	33-2038	VA-269
5873104530	VO-162	8944567411	VO-52	2C2N3587	VO-86	HP-2011	VO-88	33-2040	VA-413
5876100310	VO-161	8944567412	VO-106	K&N		HP-3001	VO-1	33-2041-1	VA-414
5876100400	VO-162	8944597000	VO-52	E-0644	VA-266	HP-3001	VO-15	33-2042	VA-108
8064383840	VO-56	8944656560	VA-408	E-0771	VA-196	HP-3002	VO-56	33-2045	VA-99
8064842350	VA-2	8944656562	VA-408	E-0773	VA-181	HP-3003	VO-75	33-2047	VA-103
8150361410	VA-161	8944937080	VA-408	E-0774	VA-161	HP-4001	VO-135	33-2048	VA-105
8152024080	VA-181	8970254631	VO-162	E-0776	VA-177	HP-4002	VO-46	33-2049	VA-106
8159424290	VA-219	897035303	VFAP-7859	E-0778	VA-329	HP-4003	VO-64	33-2050-1	VA-96
8193039750	VO-88	8970353030	VFAP-7859	E-0780	VA-174	HP-4005	VO-104	33-2052	VA-102
82501043770	VO-108	8970492820	VO-162	E-0781	VA-218	HP-6001	VO-63	33-2054	VA-125
8250106330	VO-58	8970497080	VO-35	E-0784	VA-264	PF-1000	VG-14	33-2055	VA-101
8250107920	VO-16	8970497081	VO-35	E-0785	VA-239	PF-2100	VG-33	33-2056	VA-111
8250143770	VO-108	8970645580	VFAP-7859	E-0787	VA-264	PF-2200	VG-16	33-2057	VA-78
8250146930	VO-16	8970656760	VA-408	E-0890	VA-85	PF-2300	VG-32	33-2058	VA-132
8250148310	VO-56	8970967770	VO-161	E-0940	VA-89	PF-2400	VG-30	33-2059	VA-389
8250409290	VA-38	8971114230	VFAP-7859	E-0945	VA-94	VF1001	VCA-1041	33-2060	VA-84
8250550520	VG-14	8971364700	VO-161	E-0995	VA-114	VF1003	VCA-1139	33-2062-1	VA-412
8250551290	VG-14	8971406660	VO-106	E-0998	VFAP-1613	VF1010	VCA-1097	33-2063-1	VA-109
8250984630	VA-108	8971482700	VO-161	E-1006	VA-137	VF1011	VCA-1118	33-2064	VFAP-7859
8251605610	VO-56	8971679731	VO-106	E-1007	VA-155	VF1012	VCA-1080	33-2066-1	VA-107

CAUTION: For general references only. Check catalog for correct filter application. Any use of this interchange to determine filter application is done at the installers risk.

PRECAUCION: Solamente para referencias generales. Revise el catálogo para la correcta aplicación del filtro. Cualquier uso de la referencia cruzada para determinar la aplicación del filtro es riesgo del instalador. ATTENTION : Seulement pour les références d'ordre général. Contrôler l'application correcte du filtre avec le catalogue. Toute utilisation de moyens afin de déterminer l'application d'un filtre est faite aux risques de l'installateur.

Cross Reference

Table da equivalencias da fabricantes

Code de renvoi au fabricant

MFR'S NUMBER	REPLACEMENT NUMBER	MFR'S NUMBER	REPLACEMENT NUMBER	MFR'S NUMBER	REPLACEMENT NUMBER	MFR'S NUMBER	REPLACEMENT NUMBER	MFR'S NUMBER	REPLACEMENT NUMBER
K&N		33-2181	VA-132	33-2305	VA-109	33-2392	VA-278	33-2613	VA-83
33-2067	VA-112	33-2182	VA-166	33-2306	VA-248	33-2394	VA-225	33-2615	VFAP-7908
33-2068	VA-110	33-2186	VA-399	33-2308	VA-197	33-2395	VA-224	33-2670	VFAP-7912
33-2069	VA-124	33-2187	VA-149	33-2309	VA-202	33-2397	VA-282	33-2672	VFAP-7892
33-2070	VFAP-7865	33-2188	VA-152	33-2310	VA-109	33-2399	VA-332	33-2675	VA-157
33-2071	VA-113	33-2190	VA-394	33-2311	VA-203	33-2400	VA-354	33-2676	VA-397
33-2072	VA-104	33-2192	VA-165	33-2312	VA-359	33-2401	VA-241	33-2680	VA-152
33-2074	VA-387	33-2195	VA-205	33-2313	VA-382	33-2402	VA-221	33-2708	VA-413
33-2075	VA-86	33-2196	VA-346	33-2319	VA-380	33-2403	VA-220	33-2752	VA-341
33-2078	VA-395	33-2198	VA-172	33-2320	VA-188	33-2404	VA-236	33-2753	VA-131
33-2084	VA-90	33-2199	VA-345	33-2321	VA-142	33-2406	VA-373	33-2763	VA-90
33-2086	VA-78	33-2200	VA-192	33-2323	VA-210	33-2408	VA-219	33-2764	VA-380
33-2087	VA-69	33-2201	VA-193	33-2324	VA-356	33-2409	VA-261	33-2788	VA-347
33-2091-1	VFAP-7857	33-2204	VA-157	33-2325	VA-386	33-2411	VA-263	33-2819	VA-140
33-2093	VA-70	33-2206	VA-154	33-2326	VA-209	33-2418	VA-315	33-2843	VA-84
33-2094	VA-98	33-2207	VA-162	33-2327	VA-379	33-2419	VA-154	33-2865	VA-274
33-2099	VA-70	33-2209	VA-325	33-2329	VA-251	33-2420	VA-164	33-2873	VA-314
33-2104	VA-135	33-2211	VA-191	33-2330	VA-340	33-2422	VA-250	33-2878	VA-365
33-2105	VA-153	33-2216	VA-170	33-2331	VA-223	33-2423	VA-245	33-2887	VA-228
33-2106-1	VA-260	33-2220	VA-279	33-2332	VA-323	33-2424	VA-215	33-2888	VA-318
33-2107	VA-404	33-2225	VA-108	33-2334	VA-200	33-2426	VA-358	33-2919	VA-375
33-2108	VFAP-7859	33-2229	VA-370	33-2335	VA-362	33-2427	VA-383	33-2924	VA-319
33-2110	VA-370	33-2231	VFAP-7865	33-2336	VA-86	33-2428	VA-444	33-2934	VA-243
33-2111	VFAP-917	33-2232	VA-86	33-2338	VA-328	33-2430	VA-294	33-2936	VA-447
33-2112	VA-128	33-2233	VA-164	33-2339	VA-217	33-2431	VA-253	33-2940	VA-371
33-2114	VA-129	33-2234	VA-103	33-2340	VA-216	33-2432	VA-330	33-2941	VA-326
33-2115-1	VFAP-1613	33-2239	VA-199	33-2342	VA-212	33-2433	VA-366	33-2945	VA-313
33-2118	VFAP-917	33-2241	VA-125	33-2343	VA-237	33-2434	VA-280	33-2955	VA-284
33-2119	VA-347	33-2246	VA-342	33-2344	VA-353	33-2435	VA-257	33-2958	VA-378
33-2120	VFAP-7908	33-2247	VA-160	33-2345	VA-289	33-2436	VA-267	33-2960	VA-268
33-2121-1	VA-91	33-2248	VA-167	33-2346	VA-227	33-2437	VA-275	33-2962	VA-254
33-2122	VA-90	33-2249	VA-176	33-2347	VA-249	33-2439	VA-255	33-2963	VA-443
33-2123	VA-410	33-2250	VA-78	33-2348	VA-357	33-2440	VA-391	33-2964	VA-285
33-2124	VA-117	33-2251	VA-335	33-2349	VA-360	33-2442	VA-254	33-2966	VA-296
33-2125	VA-157	33-2252	VA-171	33-2351	VA-213	33-2443	VA-273	33-2995	VA-449
33-2126	VA-69	33-2253	VA-366	33-2353	VA-222	33-2448	VA-265	33-3080	VA-500
33-2127	VA-120	33-2255	VA-341	33-2354	VA-201	33-2451	VA-283	33-5000	VA-306
33-2128	VA-138	33-2260	VA-163	33-2355	VA-209	33-2452	VA-445	33-5001	VA-429
33-2129	VA-259	33-2264	VA-363	33-2356	VA-336	33-2454	VA-390	33-5002	VA-298
33-2132	VFAP-1612	33-2265	VA-347	33-2357	VA-215	33-2457	VA-273	33-5005	VA-264
33-2133	VA-118	33-2266	VA-142	33-2358	VA-211	33-2458	VA-396	33-5007	VA-424
33-2134	VFAP-7893	33-2268	VA-185	33-2359	VA-242	33-2460	VA-293	33-5009	VA-434
33-2135	VA-324	33-2269	VA-350	33-2360	VA-231	33-2461	VA-291	33-5010	VA-266
33-2136	VA-116	33-2270	VA-355	33-2361	VA-374	33-2462	VA-286	33-5013	VA-419
33-2137	VA-339	33-2271	VA-247	33-2362	VA-229	33-2464	VA-327	33-5014	VA-244
33-2139	VA-105	33-2272	VA-205	33-2363	VA-232	33-2465	VA-423	33-5016	VA-438
33-2141-1	VA-78	33-2272	VA-205	33-2364	VA-258	33-2466	VA-295	33-5017	VA-440
33-2142	VA-157	33-2275	VA-175	33-2366	VA-162	33-2468	VA-292	33-5024	VA-451
33-2143	VA-65	33-2276	VA-183	33-2367	VA-317	33-2470	VA-287	33-5025	VA-428
33-2144	VA-146	33-2277	VA-184	33-2368	VA-230	33-2471	VA-310	33-5027	VA-432
33-2145-1	VA-102	33-2278	VA-190	33-2369	VA-360	33-2472	VA-300	33-5029	VA-430
33-2146	VA-146	33-2279	VA-194	33-2370	VA-214	33-2473	VA-297	33-5030	VA-425
33-2149	VA-157	33-2280	VA-352	33-2371	VA-368	33-2474	VA-452	33-5031	VA-431
33-2150	VA-149	33-2281	VA-195	33-2372	VA-367	33-2475	VA-299	33-5034	VA-455
33-2152	VA-350	33-2282	VA-377	33-2373	VA-154	33-2476	VA-426	33-5037	VA-466
33-2153	VA-156	33-2283	VA-189	33-2374	VA-233	33-2477	VA-307	33-5041	VA-456
33-2154	VA-150	33-2284	VA-330	33-2375	VA-244	33-2478	VA-312	33-5044	VA-464
33-2155	VA-144	33-2285	VA-206	33-2376	VA-238	33-2479	VA-301	33-5045	VA-454
33-2156	VA-109	33-2286	VA-105	33-2377	VA-252	33-2480	VA-302	33-5049	VA-459
33-2157	VA-136	33-2287	VA-182	33-2378	VA-240	33-2482	VA-392	33-5056	VA-467
33-2160	VA-151	33-2288	VA-179	33-2379	VA-351	33-2485	VA-344	K&N PRO SERIES	
33-2163	VA-84	33-2290	VA-400	33-2380	VA-235	33-2487	VA-473	PS-1001	VO-16
33-2168	VA-147	33-2292	VA-337	33-2381	VA-309	33-2489	VA-393	PS-1002	VO-25
33-2169	VA-178	33-2293	VA-207	33-2382	VA-357	33-2491	VA-303	PS-1003	VO-40
33-2170	VA-159	33-2294	VA-364	33-2383	VA-202	33-2492	VA-427	PS-1004	VO-106
33-2174	VA-270	33-2295	VA-180	33-2384	VA-365	33-2493	VA-311	PS-1007	VO-58
33-2175	VA-90	33-2296	VA-176	33-2385	VA-223	33-2496	VA-457	PS-1008	VO-106
33-2176	VA-333	33-2298	VA-186	33-2386	VA-316	33-2497	VA-308	PS-1010	VO-106
33-2177-1	VA-190	33-2299	VA-118	33-2387	VA-234	33-2498	VA-304	PS-1011	VO-65
33-2178	VA-361	33-2300	VA-171	33-2389	VA-372	33-2512	VA-157	PS-1015	VO-106
33-2179	VA-148	33-2304	VA-198	33-2391	VA-349	33-2599	VA-389	PS-1017	VO-88

CAUTION: For general references only. Check catalog for correct filter application. Any use of this interchange to determine filter application is done at the installers risk.
 PRECAUCION: Solamente para referencias generales. Revise el catálogo para la correcta aplicación del filtro. Cualquier uso de la referencia cruzada para determinar la aplicación del filtro es riesgo del instalador. ATTENTION : Seulement pour les références d'ordre général. Contrôler l'application correcte du filtre avec le catalogue. Toute utilisation de moyens afin de déterminer l'application d'un filtre est faite aux risques de l'installateur.

Cross Reference

Table da equivalencias da fabricantes

Code de renvoi au fabricant

MFR'S NUMBER	REPLACEMENT NUMBER	MFR'S NUMBER	REPLACEMENT NUMBER	MFR'S NUMBER	REPLACEMENT NUMBER	MFR'S NUMBER	REPLACEMENT NUMBER	MFR'S NUMBER	REPLACEMENT NUMBER
K&N PRO SERIES									
PS-2001	VO-55	1UF79-AQ000	VCA-1071	AW33	VO-52	LA347	VCA-1139	LX1631	VA-244
PS-2002	VO-65	2TF79-AQ000	VCA-1075	AW34	VO-25	LA395	VCA-1031	LX1661	VA-213
PS-2003	VO-108	26300-2Y500	VO-106	AW35	VO-25	LA396	VCA-1034	LX1662	VA-164
PS-2004	VO-95	26300-35500	VO-106	AW36	VO-106	LA435	VCA-1063	LX1700	VA-146
PS-2005	VO-15	26300-35501	VO-106	AW38	VO-65	LA452	VCA-1114	LX1723	VA-138
PS-2006	VO-108	26300-35502	VO-106	AW39	VO-95	LA46	VCA-1123	LX1751	VA-318
PS-2008	VO-25	26300-35503	VO-106	AW39C10	VO-95	LA461	VCA-1055	LX1768	VA-196
PS-2009	VO-118	26300-35504	VO-106	AW40	VO-40	LA472	VCA-1078	LX1780	VA-288
PS-2010	VO-88	26320-3C100	VO-90	AW41	VO-108	LA473	VCA-1053	LX1780/3	VA-288
PS-2011	VO-88	26320-3C300	VO-99	AW45	VO-95	LA49	VCA-1029	LX1785	VA-208
PS-3001	VO-1	26320-3F000	VO-99	AW46	VO-95	LA493	VCA-1044	LX1791	VA-396
PS-3002	VO-56	26330-3C100	VO-90	AW47	VO-15	LA531	VCA-1115	LX1808	VA-201
PS-3003	VO-75	26330-3C250	VO-99	AW52	VO-40	LA54	VCA-1040	LX1809	VA-228
PS-3004	VO-101	28113-A9100	VO-418	AW59	VO-40	LA758	VCA-1002	LX1818	VA-178
PS-4003	VO-64	28113-B2000	VA-300	AW62	VO-25	LA760	VCA-1065	LX1845	VA-349
PS-6001	VO-63	28113B2000	VA-300	AW67	VO-95	LA763	VCA-1022	LX1850/S	VA-371
PS-7000	VO-76	28113-08000	VA-208	AW78	VO-1	LA767	VCA-1113	LX1850/1	VA-371
PS-7001	VO-73	28113-1G000	VA-201	AW85	VO-19	LA768	VCA-1038	LX1850/2	VA-371
PS-7002	VO-66	28113-2F000	VA-193	AW85	VO-35	LA770	VCA-1043	LX1949	VA-242
PS-7003	VO-67	28113-2G000	VA-243	AW87	VO-25	LA771S	VCA-1048	LX1955	VA-247
PS-7004	VO-103	28113-2J000	VA-384	AW93	VO-40	LA774	VCA-1008	LX1969	VA-326
PS-7005	VO-150	28113-2K000	VA-268	AW94	VO-27	LA777	VCA-1075	LX1991	VA-423
PS-7006	VO-74	28113-3E000	VA-247	EH258	VO-95	LA778	VCA-1144	LX1997	VA-426
PS-7007	LC-8170	28113-3E500	VA-247	F0319	VO-40	LA779	VCA-1170	LX2001	VA-330
PS-7008	VO-62	28113-3S100	VA-265	F0354	VO-95	LA78	VCA-1163	LX2038	VA-316
PS-7009	VO-81	28113-3Z100	VA-283	F0355	VO-95	LA780	VCA-1073	LX2046	VA-313
PS-7010	VO-85	28113-39000	VA-345	F0355/1	VO-95	LA782	VCA-1077	LX2067/3	VA-490
PS-7011	VO-127	28113-4D000	VA-230	F0355/14	VO-95	LA79	VCA-1161	LX2076/1	VA-490
PS-7013	VO-80	3RF79-AQ000	VCA-1075	F0371	VO-1	LA93	VCA-1124	LX2077/3	VA-450
PS-7014	VO-91	4DF79-AQ000	VCA-1075	F0373	VO-95	LKK116/S	VCA-1126	LX2091D	VA-448
PS-7015	VO-92	97133-A9000	VCA-1075	F0373/6	VO-95	LX1005	VA-181	LX2123	VA-212
PS-7016	VO-97	97133-B2000	VCA-1179	F0385	VO-95	LX1006/2D	VA-329	LX251	VA-69
PS-7017	VO-137	97133-C1000	VCA-1181	F0385/1	VO-159	LX1030	VA-193	LX2525	VA-444
PS-7018	VO-96	97133-D3000	VCA-1190	KL158	VG-14	LX1039	VA-152	LX2562	VA-259
PS-7020	VO-84	97133-D3200	VCA-1190	KL665	VG-32	LX104	VA-403	LX2563	VA-260
PS-7021	VO-102	97133-J5000	VCA-1062	KL692	VG-33	LX1040	VA-345	LX2570	VA-234
PS-7022	VO-90	97133-1U000	VCA-1071	KL801	VG-16	LX1041	VA-172	LX259	VA-69
PS-7023	VO-87	97133-2B010	VCA-1035	LAK102	VCA-1162	LX1046	VA-199	LX2612	VA-374
PS-7024	VO-111	97133-2D000	VCA-1066	LAK131	VCA-1133	LX1049	VA-135	LX2615OF	VA-293
PS-7025	VO-110	97133-2E210	VCA-1047	LAK181	VCA-1135	LX105	VA-389	LX2639	VA-247
PS-7026	VO-114	97133-2E210	VCA-1047	LAK247	VCA-2033	LX1076	VA-153	LX2672	VA-198
PS-7027	VO-98	97133-2F000	VCA-1050	LAK250	VCA-1131	LX11	VA-2	LX2679	VA-340
PS-7028	VO-129	97133-2F010	VCA-1050	LAK413	VCA-1153	LX1103	VA-102	LX2688	VA-294
PS-7029	VO-99	97133-2K000	VCA-1115	LAK485	VCA-1147	LX12	VA-403	LX2693	VA-250
PS-7030	VO-109	97133-3A100	VCA-1062	LAK63	VCA-1166	LX1211	VA-274	LX2739	VA-268
PS-7031	VO-77	97133-3E260	VCA-1053	LAK73/S	VCA-1127	LX1249	VA-363	LX2750	VA-234
PS-7035	VO-167	97133-3E270	VCA-1053	LAK740	VCA-1078C	LX1250	VA-367	LX2752	VA-235
PS-7037	VO-115	97133-3K000	VCA-1035	LAK769S	VCA-1164	LX1252	VA-364	LX2787	VA-443
		97133-3SAA0	VCA-1075	LAK772S	VCA-1159	LX1253	VA-329	LX2792	VA-231
		97134-C6900	VCA-1188	LAK79	VCA-1161	LX1262	VA-318	LX2813	VA-435
KIA									
A7F79-AQ000	VCA-1051	97619-3C100	VCA-1139	LAK888	VCA-1189	LX1266	VFAP-7908	LX2832	VA-240
A979-AC000	VCA-1075	97619-3E000	VCA-1139	LAK93	VCA-1166	LX1269	VA-355	LX2837	VA-310
C6C79-AC000	VCA-1188	97619-38100	VCA-1139	LA100	VCA-1122	LX1272	VA-105	LX2837OF	VA-310
FE3R1-43-02	VO-106	KNECHT/MAHLE		LA102	VCA-1162	LX1273	VA-342	LX2863	VA-377
F784EB9AA	VCA-1075	AG108	VA-69	LA109	VCA-1042	LX1285	VA-149	LX2870	VA-257
J5H79-AK000	VCA-1062	AW1	VO-1	LA122	VCA-1012	LX1286	VA-171	LX2889	VA-366
K551-14-302	VO-157	AW100	VO-19	LA131	VCA-1014	LX1298	VA-261	LX2927	VA-155
OB631-14-301	VO-106	AW136	VO-19	LA157	VCA-1028	LX1456	VA-149	LX2929	VA-217
OB631-14-302	VO-106	AW139	VO-95	LA171	VCA-1056	LX1478	VA-323	LX2948	VA-78
OFE3R-14-302	VO-106	AW14	VO-40	LA172	VCA-1167	LX1482	VA-274	LX2955	VA-188
OJE15-14-302	VO-106	AW144	VO-15	LA180	VCA-1036	LX1500	VA-365	LX2957	VA-265
OK011-13-Z40	VA-147	AW168	VO-15	LA183	VCA-1020	LX1518	VA-150	LX3000	VA-358
OK2A5-13-Z40	VA-178	AW169	VO-25	LA199	VCA-1067	LX1564	VA-317	LX3002	VA-383
OK2A5-13-Z40A	VA-178	AW18	VO-95	LA216	VCA-1063	LX159312	VA-315	LX3015	VA-471
OK30C-13-Z40A	VA-346	AW18C10	VO-95	LA241/3	VCA-1120	LX1593/2	VA-315	LX3016	VA-309
OK52Y-13-33X	VA-185	AW29	VO-40	LA25	VCA-1157	LX1605	VA-314	LX3020	VA-254
OK551-14-302	VO-157	AW29/8	VO-15	LA298	VCA-1050	LX1607/1	VA-354	LX3021	VA-245
OVS01-14-302	VO-136	AW29/9	VO-15	LA307	VCA-1142	LX1611	VA-170	LX3024	VA-265
P8790-1F200A	VCA-1047	AW29/9	VO-15	LA31	VCA-1026	LX1612	VA-163	LX3045	VA-471
P8790-2G000A	VCA-1072	AW29/9C10	VO-15	LA343	VCA-1035	LX1613	VA-279	LX307	VA-86
P8790-2K000A	VCA-1115	AW3	VO-40	LA346/S	VCA-1046	LX1625	VA-346	LX3070	VA-332

CAUTION: For general references only. Check catalog for correct filter application. Any use of this interchange to determine filter application is done at the installers risk.

PRECAUCION: Solamente para referencias generales. Revise el catálogo para la correcta aplicación del filtro. Cualquier uso de la referencia cruzada para determinar la aplicación del filtro es riesgo del instalador. ATTENTION : Seulement pour les références d'ordre général. Contrôler l'application correcte du filtre avec le catalogue. Toute utilisation de moyens afin de déterminer l'application d'un filtre est faite aux risques de l'installateur.

Cross Reference

Table da equivalencias da fabricantes

Code de renvoi au fabricant

MFR'S NUMBER	REPLACEMENT NUMBER	MFR'S NUMBER	REPLACEMENT NUMBER	MFR'S NUMBER	REPLACEMENT NUMBER	MFR'S NUMBER	REPLACEMENT NUMBER	MFR'S NUMBER	REPLACEMENT NUMBER
KNECHT/MAHLE		LX868	VA-352	OC323	VO-86	OX350	VO-138	4508334	VO-86
LX3071	VA-336	LX886	VA-347	OC330	VO-106	OX350D	VO-138	6G9N-180543-BA	VCA-1158
LX3079	VA-224	LX888	VA-394	OC36	VO-95	OX351D ECO	VO-99	MANN & HUMMEL	
LX3086	VA-117	LX9	VA-402	OC375	VO-118	OX353/3	VO-131	A539	VA-83
LX3087	VA-270	LX942	VA-142	OC456	VO-101	OX353/3D	VO-131	CA2970	VA-108
LX3090	VA-202	LX944	VA-337	OC460	VO-118	OX353/7D	VO-131	CUK20000-2	VCA-1126
LX3091	VA-237	LX982	VA-364	OC47	VO-15	OX355	VO-167	CUK22022	VCA-1187
LX3095	VA-220	LX989	VA-99	OC472	VO-124	OX356D	VO-150	CUK2231	VCA-1147
LX3096	VA-252	L18	VO-19	OC485	VO-15	OX358D	VO-94	CUK24003	VCA-1183
LX3097	VA-221	OC100	VO-52	OC485	VO-93	OX367D	VO-128	CUK2442	VCA-1078C
LX3099	VA-192	OC105	VO-15	OC49	VO-15	OX370D	VO-85	CUK2550	VCA-1153
LX3140	VA-442	OC107	VO-108	OC494	VO-16	OX370D2 ECO	VO-85	CUK2551	VCA-1153
LX3158	VA-286	OC108	VO-15	OC51	VO-15	OX371D	VO-116	CUK26017	VCA-1075
LX3209	VA-375	OC109	VO-25	OC57	VO-95	OX371D ECO	VO-116	CUK2733	VCA-1108
LX3210	VA-360	OC109/1	VO-25	OC58	VO-95	OX379D	VO-85	CUK2736-2	VCA-1127
LX3214	VA-361	OC110	VO-15	OC602	VO-86	OX380D	VO-129	CUK2862	VCA-1166
LX3216	VA-328	OC113	VO-19	OC613	VO-170	OX381D	VO-92	CUK2882	VCA-1166
LX3217	VA-357	OC114	VO-56	OC614	VO-88	OX387D	VO-91	CUK29005	VCA-1153
LX3218	VA-390	OC115	VO-106	OC62	VO-159	OX388	VO-132	CUK2939	VCA-1135
LX3219	VA-372	OC117	VO-65	OC67	VO-1	OX388D	VO-132	CUK3037	VCA-1124
LX3220	VA-362	OC118	VO-108	OC68	VO-16	OX388D ECO	VO-132	CUK3461	VCA-1106
LX3222	VA-370	OC120	VO-25	OC69	VO-108	OX401D	VO-98	CUK6724	VCA-1162
LX3225	VA-282	OC123	VO-95	OC707	VO-106	OX413D2	VO-87	CUK8430	VCA-1103
LX3227	VA-386	OC138	VO-19	OC711	VO-106	OX414D1	VO-84	CU15001	VCA-1171
LX3228	VA-379	OC140	VO-95	OC713	VO-95	OX416D1	VO-102	CU1764	VCA-1028
LX3229	VA-158	OC141	VO-95	OC715	VO-16	OX416D2	VO-121	CU1811-2	VCA-1093
LX3230	VA-273	OC142	VO-135	OC74	VO-25	OX417	VO-109	CU1828	VCA-1042
LX3300	VA-300	OC18	VO-95	OC75	VO-135	OX554D2	VO-96	CU1919	VCA-1031
LX336	VA-401	OC182	VO-25	OC77	VO-27	OX556D	VO-139	CU21002-2	VCA-1145
LX3424	VA-488	OC194	VO-106	OC85	VO-15	OX636D	VO-112	CU21003	VCA-1061
LX343	VFAP-7865	OC195	VO-106	OC90	VO-16	OX68D	LC-834	CU21009	VCA-1179
LX3443	VA-291	OC196	VO-106	OC976	VO-52	OX774D	VO-141	CU2131	VCA-1014
LX350	VA-416	OC204	VO-95	OC981	VO-25	OX786D	VO-110	CU2138	VCA-1109
LX3502	VA-453	OC205	VO-106	OC986	VO-106	OX814D	VO-149	CU2141	VCA-1068
LX3503	VA-453	OC209	VO-15	OF478	VO-25	OX815D	VO-166	CU22002-2	VCA-1160
LX405	VA-124	OC21	VO-25	OL238	VO-86	OX815D ECO	VO-166	CU22003	VCA-1114
LX408	VA-395	OC215	VO-40	OX104	VO-62	OX835D	VO-117	CU22004	VCA-1055
LX4085	VA-455	OC216	VO-40	OX105	VO-62	OX91	LC-833	CU2224-2	VCA-1021
LX4590	VA-466	OC217	VO-40	OX105D	VO-62	OX91D	LC-833	CU2227	VCA-1069
LX494	VA-341	OC217/6	VO-40	OX122D	VO-119	OX92D	VO-70	CU2252	VCA-1068
LX511	VA-380	OC218	VO-40	OX125	VO-150	OX982D	VO-164	CU2327	VCA-1012
LX522	VFAP-1612	OC223	VO-35	OX127/1D	LC-8445	OX982D ECO	VO-164	CU2328	VCA-1116
LX534	VFAP-7893	OC225	VO-15	OX128D	VO-127	OX983D	VO-133	CU2329	VCA-1036
LX542	VA-397	OC229	VO-52	OX128/1D	VO-127	OX983D ECO	VO-133	CU2330	VCA-1146
LX543	VA-106	OC23	VO-95	OX133D	VO-62	OX99	VO-144	CU2356	VCA-1066
LX551	VFAP-7865	OC230	VO-19	OX1411D	VO-120	LAND ROVER		CU2362	VCA-1035
LX573	VA-40	OC231	VO-25	OX143D	VO-71	AHU2880	VO-124	CU2368	VCA-1122
LX577	VA-90	OC235	VO-25	OX149D	VO-66	CDU1268	VO-124	CU24003	VCA-1184
LX588	VA-86	OC236	VO-95	OX152D	VO-74	C2N3587	VO-86	CU24009	VCA-1175
LX591	VA-104	OC237/1	VO-124	OX152/1D	VO-74	ERR3340	VO-95	CU2434	VCA-1050
LX596	VA-90	OC240	VO-15	OX153	VO-69	ESR3117	VG-14	CU2436	VCA-1177
LX6	VA-321	OC241	VO-15	OX154	LC-8170	ESR4065	VG-14	CU2440	VCA-1172
LX622	VA-157	OC256	VO-60	OX154/1D	LC-8170	ESR4238	VA-347	CU2442	VCA-1078
LX637	VA-350	OC261	VO-95	OX160D	VO-150	JM0000010	VCA-1156	CU2450	VCA-1194
LX667	VA-83	OC262	VO-1	OX175D	VO-82	LPW100180	VO-124	CU26009	VCA-1189
LX684	VA-138	OC262	VO-93	OX177/3	VO-140	LPW100230	VO-124	CU26017	VCA-1075
LX700	VFAP-7912	OC264	VO-15	OX179D	VO-137	LRW500030	VO-74	CU2622	VCA-1075
LX722	VA-333	OC265	VO-35	OX182D	VO-73	LR000899	VCA-1158	CU2623	VCA-1041
LX722	VA-109	OC266	VO-15	OX183/2D ECO	VO-151	LR000901	VCA-1108	CU2647	VCA-1139
LX792	VA-204	OC273	VO-15	OX187D	VO-130	LR001247	VO-111	CU2650	VCA-1161
LX798	VA-140	OC274	VO-136	OX188D	VO-77	LR001419	VO-97	CU27008	VCA-1073
LX799	VFAP-1613	OC275	VO-145	OX188D ECO	VO-77	LR004459	VO-111	CU2733	VCA-1158
LX804/S	VA-132	OC279	VO-15	OX195	VO-106	LR007160	VO-86	CU2855	VCA-1040
LX807	VA-414	OC28	VO-95	OX203D	VO-80	LR011279	VO-141	CU2856/1	VCA-1002
LX811	VFAP-7892	OC281	VO-143	OX238/1D	LC-8445	LR011593	VA-446	CU2882	VCA-1026
LX819	VA-325	OC288	VO-88	OX258	VO-76	LR019192	VCA-1158	CU29001	VCA-1038
LX826	VFAP-7908	OC295	VO-25	OX258D ECO	VO-76	LR019589	VCA-1108	CU3037	VCA-1124
LX837	VA-408	OC297	VO-146	OX339/2D	VO-111	LR025306	VO-25	CU3192	VCA-1123
LX839	VA-128	OC310	VO-52	OX345	VO-103	LR031439	VO-86	CU3461	VCA-1106
LX843	VA-387	OC311	VO-93	OX345D	VO-103	LR056138	VCA-1108	CU3567	VCA-1163
LX848	VA-103	OC320	VO-64	OX346D	VO-120	4454116	VO-118	CU3569	VCA-1142

CAUTION: For general references only. Check catalog for correct filter application. Any use of this interchange to determine filter application is done at the installers risk.
 PRECAUCION: Solamente para referencias generales. Revise el catálogo para la correcta aplicación del filtro. Cualquier uso de la referencia cruzada para determinar la aplicación del filtro es riesgo del instalador. ATTENTION : Seulement pour les références d'ordre général. Contrôler l'application correcte du filtre avec le catalogue. Toute utilisation de moyens afin de déterminer l'application d'un filtre est faite aux risques de l'installateur.

Cross Reference

Table da equivalencias da fabricantes

Code de renvoi au fabricant

MFR'S NUMBER	REPLACEMENT NUMBER	MFR'S NUMBER	REPLACEMENT NUMBER	MFR'S NUMBER	REPLACEMENT NUMBER	MFR'S NUMBER	REPLACEMENT NUMBER	MFR'S NUMBER	REPLACEMENT NUMBER
MANN & HUMMEL		C25654	VA-437	C30189	VA-333	HU612/2x	VO-98	H921/x	LC-833
CU3822-2	VCA-1058	C2568	VA-414	C30198	VA-232	HU68x	VO-120	H9253X	LC-8170
CU4151	VCA-1029	C26003	VA-209	C3027/1	VA-113	HU69/1	VO-76	H926/3X	LC-834
CU4624	VCA-1056	C26008	VA-283	C3028	VA-340	HU69/2	VO-76	H926/4x	LC-834
CU4727	VCA-1170	C26014	VA-268	C3033	VA-247	HU69/2x	VO-76	H932/5X	VO-144
CU5257	VCA-1157	C26022	VA-334	C3055	VA-403	HU7001x	VO-99	H936/1	VO-134
CU5366	VCA-1156	C26033	VA-300	C31101/1	VA-84	HU7004/1x	VO-153	H936/1x	VO-134
CU6724	VCA-1162	C26036	VA-417	C31126	VA-102	HU7005x	VO-138	H97W08	VO-106
CU8430	VCA-1103	C26100	VA-149	C31130	VA-394	HU7008z	VO-132	MA1234	VA-343
C1430	VA-196	C26106	VA-285	C31149/1	VA-364	HU7011y	VO-168	MW712	VO-25
C16114x	VA-448	C26108	VA-285	C3145	VFAP-7859	HU7018z	VO-142	MW810	VO-106
C16114/1x	VA-448	C26110/1	VA-389	C32014	VA-234	HU7020z	VO-165	P829/1x	VO-70
C16118	VA-329	C26151	VA-157	C321	VO-136	HU7020z	VO-165	P9009	VO-170
C17016	VA-366	C26168	VA-157	C3210	VA-435	HU7025z	VO-149	WF914	VO-95
C17137/1x	VA-329	C26168/2	VA-157	C32120/2	VA-233	HU7029z	VO-92	WF916	VO-95
C1724	VA-242	C2620	VA-171	C32130	VA-313	HU7044/z	VO-164	WF916/1	VO-95
C1761	VA-114	C2631	VA-208	C3220	VA-319	HU711X	VO-80	WK612/2	VG-14
C18004	VA-250	C2632/1	VA-172	C3233	VA-190	HU711/2x	VO-80	WK719/4	VO-15
C19003	VA-327	C2658	VA-346	C32338	VA-380	HU711/51x	VO-111	WK8046	VG-16
C20010	VA-303	C2661	VA-131	C3261	VFAP-1613	HU711/6z	VO-164	WP1045	VO-146
C20033	VA-432	C2666	VA-397	C3270	VA-142	HU713/1x	VO-116	WP9002	VO-136
C2029	VA-235	C2667	VA-346	C33130	VA-395	HU715/3x	LC-8445	WP928/80	VO-145
C2041	VA-40	C2673	VA-321	C33194	VA-352	HU715/4x	LC-8445	WP928/81	VO-136
C2055	VA-135	C2676	VA-193	C3397	VA-452	HU715/5X	VO-128	WP928/82	VO-155
C2065	VA-106	C2679	VA-131	C35124	VA-90	HU718/1K	VO-69	WP928/83	VO-136
C21002	VA-455	C2681	VA-156	C35126	VA-446	HU718/1x	VO-69	WP928/84	VO-155
C2136/1	VA-153	C27000-2	VA-371	C35127	VFAP-7912	HU718/4x	VO-69	W10004	VO-64
C2138/3	VA-103	C27004	VA-449	C35148	VFAP-7912	HU718/5x	VO-103	W1130/1	VO-15
C2147	VA-40	C27006	VA-371	C35154	VA-274	HU718/8x	VO-138	W1150/2	VO-163
C22009	VA-257	C27026	VA-490	C35154/1	VA-274	HU719/5x	VO-127	W12205	VO-162
C2237	VA-199	C27107	VA-296	C35178	VFAP-7912	HU719/6x	VO-85	W1228	VO-161
C2262	VA-408	C27114	VA-323	C35215	VA-350	HU719/7x	VO-77	W1262	VO-162
C2266	VA-216	C27125	VA-443	C3594/1	VA-90	HU719/8	VO-85	W610/1	VO-40
C2266 N-HF	VA-216	C27154/1	VA-124	C36002	VA-326	HU719/8x	VO-85	W610/2	VO-106
C2278	VA-215	C27192/1	VA-325	C36003	VA-447	HU721/2x	VO-137	W610/3	VO-106
C2278N-HF	VA-215	C2731/1	VFAP-7892	C36004	VA-317	HU721/4X	VO-140	W610/6	VO-106
C23006	VA-227	C2733	VA-147	C36015	VA-467	HU722Z	VO-92	W610/80	VO-40
C2304	VA-188	C2735	VA-240	C36110	VA-217	HU726/1x	VO-71	W610/81	VO-106
C2329	VFAP-7908	C2739	VA-148	C36110N-HF	VA-217	HU726/2X	VO-71	W610/82	VO-106
C2330	VA-374	C2743	VA-386	C36145	VA-373	HU727/1x	VO-62	W610/83	VO-40
C2332	VA-99	C2774/2	VA-140	C36188	VA-365	HU8007z	VO-131	W610/9	VO-40
C2335	VA-387	C2774/3KIT	VA-140	C3698	VA-132	HU8008z	VO-141	W67/1	VO-106
C2337	VA-144	C2776	VA-140	C3698-2	Requires 2	VA-132	HU8009z	VO-133	W67/2
C2372	VA-112	C28010	VA-265	C3698/3-2	Requires 2	VA-132	HU816x	VO-91	W67/80
C24005	VA-231	C28125	VA-444	C37100	VA-316	HU816/1x	VO-82	W68	VO-106
C24012	VA-424	C28125/1	VA-444	C37153	VA-138	HU816/2x	VO-82	W68/1	VO-40
C24021	VA-292	C28150	VA-105	C3725	VA-170	HU819	VO-66	W68/3	VO-40
C24025	VA-450	C2841	VA-207	C3789	VA-150	HU819x	VO-66	W68/80	VO-40
C24100	VA-154	C2850	VA-66	C38116	VA-363	HU821	VO-129	W7008	VO-25
C24125	VA-200	C2851	VA-355	C39129	VA-204	HU821x	VO-129	W7015	VO-25
C24125N-HF	VA-200	C2860	VA-69	C39201	VA-204	HU822/4	VO-112	W7030	VO-88
C24137	VA-314	C2860/1	VA-69	C39219	VA-204	HU822/4x	VO-112	W7035	VO-25
C24137/1	VA-314	C2861-2	VA-400	C40107	VFAP-1612	HU823x	VO-112	W7041	VO-25
C2420	VA-244	C29002	VA-251	C41110	VA-318	HU835/1x	VO-94	W711/80	VO-25
C2438	VA-104	C29017	VA-427	C43102	VA-226	HU921x	LC-833	W712	VO-25
C2469	VA-152	C29105	VA-341	C4312	VA-349	HU925/3x	LC-8170	W7120	VO-25
C25004	VA-371	C29130	VA-205	C4312/1	VA-349	HU925/4x	LC-8170	W7120	VO-40
C25016	VA-300	C29132	VA-367	C43139	VA-442	HU925/4y	VO-97	W712/16	VO-106
C25040	VA-438	C29145	VA-254	C5082	VA-326	HU926/3x	LC-834	W712/18	VO-106
C25114	VFAP-7865	C2941	VA-247	C570	VO-60	HU926/4	VO-130	W712/2	VO-25
C25114/1	VFAP-7865	C2964	VA-86	FP1919	VCA-1031	HU926/4x	VO-130	W712/21	VO-25
C2512/1	VA-238	C2970	VA-108	FP2440	VCA-1172	HU932/6n	VO-150	W712/22	VO-16
C25146	VA-347	C2974	VA-86	HU1032/1x	VO-119	HU932/7x	VO-150	W712/41	VO-16
C2524	VA-98	C2975	VA-164	HU514y	VO-151	HU938/3x	VO-74	W712/43	VO-25
C2526/2	VA-414	C30004	VA-453	HU6002z	VO-117	HU938/4x	VO-74	W712/47	VO-52
C2535	VA-96	C30005	VA-453	HU6007x	VO-76	H1032/1	VO-119	W712/52	VO-25
C2537/2	VA-83	C30009	VA-214	HU6015zKit	VO-166	H727/1K	VO-62	W712/73	VO-25
C2546	VA-191	C30013	VA-423	HU6018z	VO-98	H727/1X	VO-62	W712/75	VO-16
C2552/2	VA-416	C30017	VA-311	HU6019z	VO-98	H826	VO-150	W712/8	VO-52
C2562	VA-166	C30116	VA-105	HU6022z	VO-169	H826X	VO-150	W712/80	VO-25
C2564	VFAP-7893	C30139	VA-337	HU611/1x	VO-73	H829/1x	VO-70	W712/82	VO-52

CAUTION: For general references only. Check catalog for correct filter application. Any use of this interchange to determine filter application is done at the installers risk.

PRECAUCION: Solamente para referencias generales. Revise el catálogo para la correcta aplicación del filtro. Cualquier uso de la referencia cruzada para determinar la aplicación del filtro es riesgo del instalador. ATTENTION : Seulement pour les références d'ordre général. Contrôler l'application correcte du filtre avec le catalogue. Toute utilisation de moyens afin de déterminer l'application d'un filtre est faite aux risques de l'installateur.

Cross Reference

Table da equivalencias da fabricantes

Code de renvoi au fabricant

MFR'S NUMBER	REPLACEMENT NUMBER	MFR'S NUMBER	REPLACEMENT NUMBER	MFR'S NUMBER	REPLACEMENT NUMBER	MFR'S NUMBER	REPLACEMENT NUMBER	MFR'S NUMBER	REPLACEMENT NUMBER
MANN & HUMMEL		W914	VO-95	MA1008	VA-78	MA1082	VFAP-7893	MA1193	VA-242
W712/83	VO-25	W914/13	VO-19	MA1009	VA-66	MA1083	VA-181	MA1194	VA-251
W712/95	VO-25	W914/14	VO-27	MA1010	VA-102	MA1084	VFAP-1612	MA1195	VA-224
W713	VO-40	W915/9	VO-95	MA1011	VA-109	MA1085	VA-129	MA1196	VA-202
W713/1	VO-25	W916	VO-95	MA1012	VA-260	MA1086	VA-150	MA1198	VA-198
W713/15	VO-124	W916/1	VO-95	MA1013	VA-70	MA1087	VA-175	MA1199	VA-187
W713/18	VO-16	W917	VO-93	MA1014	VA-205	MA1088	VA-184	MA1200	VA-228
W713/19	VO-118	W917/97	VO-19	MA1015	VA-78	MA1089	VA-166	MA1201	VA-227
W713/20	VO-106	W917/98	VO-27	MA1016	VA-149	MA1090	VA-270	MA1202	VA-223
W713/28	VO-124	W920/14	VO-95	MA1017	VA-105	MA1091	VA-191	MA1203	VA-243
W713/29	VO-86	W920/15	VO-88	MA1018	VA-91	MA1092	VA-98	MA1204	VA-154
W713/4	VO-25	W920/16	VO-88	MA1019	VA-38	MA1093	VA-346	MA1205	VA-203
W714/2	VO-25	W920/17	VO-95	MA1020	VA-92	MA1094	VA-106	MA1206	VA-241
W714/4	VO-52	W920/21	VO-95	MA1021	VA-321	MA1095	VA-178	MA1207	VA-235
W716/1	VO-52	W920/23	VO-93	MA1022	VA-92	MA1096	VA-186	MA1209	VA-336
W717/2	VO-25	W920/24	VO-93	MA1023	VFAP-7892	MA1097	VA-179	MA1210	VA-209
W718	VO-15	W920/25	VO-19	MA1024	VA-402	MA1098	VA-172	MA1211	VA-230
W718/2	VO-95	W920/45	VO-88	MA1025	VA-104	MA1099	VA-170	MA1212	VA-252
W718/3	VO-55	W920/47	VO-35	MA1026	VA-171	MA1100	VA-247	MA1213	VA-169
W719/11	VO-52	W920/5	VO-35	MA1027	VA-163	MA1101	VA-180	MA1215	VA-381
W719/12	VO-15	W920/6	VO-95	MA1028	VA-154	MA1102	VA-408	MA1217	VA-234
W719/13	VO-15	W920/80	VO-95	MA1029	VFAP-7854	MA1103	VA-190	MA1219	VA-296
W719/15	VO-15	W920/81	VO-95	MA1030	VA-101	MA1104	VA-197	MA1220	VA-218
W719/21	VO-15	W920/96	VO-1	MA1031	VA-114	MA1105	VA-194	MA1221	VA-295
W719/22	VO-135	W920/97	VO-19	MA1032	VA-96	MA1106	VA-345	MA1230	VA-214
W719/25	VO-15	W920/98	VO-95	MA1033	VA-161	MA1107	VA-189	MA1231	VA-184
W719/27	VO-118	W920/99	VO-95	MA1034	VA-162	MA1109	VFAP-1613	MA1232	VA-220
W719/3	VO-15	W923/1	VO-1	MA1035	VA-320	MA1110	VA-185	MA1233	VA-221
W719/30	VO-15	W927/8	VO-136	MA1036	VA-117	MA1111	VA-184	MA1234	VA-343
W719/32	VO-118	W930	VO-159	MA1037	VA-160	MA1112	VA-136	MA1235	VA-237
W719/36	VO-118	W930/1	VO-86	MA1038	VA-40	MA1113	VA-207	MA1237	VA-264
W719/4	VO-15	W930/11	VO-35	MA1039	VA-110	MA1114	VA-131	MA1238	VA-246
W719/42	VO-118	W930/13	VO-86	MA1040	VA-182	MA1115	VA-188	MA1239	VA-399
W719/45	VO-101	W930/20	VO-1	MA1041	VA-164	MA1117	VA-147	MA1242	VA-353
W719/5	VO-15	W930/21	VO-1	MA1042	VA-165	MA1118	VA-208	MA1244	VA-202
W719/7	VO-86	W930/26	VO-157	MA1043	VA-125	MA1119	VA-328	MA1246	VA-359
W719/9	VO-52	W930/7	VO-159	MA1044	VA-116	MA1120	VA-279	MA1247	VA-223
W719/99	VO-40	W930/9	VO-159	MA1046	VFAP-1643	MA1121	VA-270	MA1248	VA-280
W724	VO-135	W932/81	VO-1	MA1047	VA-83	MA1122	VA-416	MA1249	VA-245
W724/5	VO-15	W933/1	VO-15	MA1048	VA-140	MA1123	VA-330	MA1250	VA-342
W735/1	VO-143	W935/98	VO-86	MA1049	VFAP-7859	MA1124	VA-386	MA1251	VA-332
W735/2	VO-143	W936/2	VO-108	MA1050	VA-112	MA1125	VA-159	MA1254	VA-289
W811/80	VO-106	W936/5	VO-56	MA1051	VA-89	MA1126-2	VA-400	MA1256	VA-351
W811/81	VO-25	W936/8	VO-65	MA1052	VA-196	MA1127	VA-414	MA1258	VA-268
W811/84	VO-25	W940/1	VO-1	MA1053	VA-183	MA1128	VA-261	MA1259	VA-294
W811/85	VO-106	W940/1N	VO-95	MA1054	VA-146	MA1129	VA-99	MA1261	VA-356
W811/85	VO-106	W940/13	VO-15	MA1055	VFAP-7908	MA1131	VA-338	MA1265	VA-244
W812/99	VO-106	W940/21	VO-1	MA1056	VA-97	MA1140	VA-195	MA1266	VA-240
W814/80	VO-106	W940/23	VO-1	MA1057	VA-135	MA1144	VA-206	MC1000-2	VCA-1003
W814/98	VO-40	W940/25	VO-15	MA1058	VA-155	MA1145	VA-269	MC1001	VCA-1002
W814/99	VO-25	W940/44	VO-15	MA1059	VA-137	MA1146	VA-216	MC1002	VCA-1008
W815/5	VO-35	W940/66	VO-15	MA1060	VFAP-917	MA1147	VA-200	MC1003	VCA-1017
W815/80	VO-106	W940/69	VO-170	MA1061	VA-114	MA1148	VA-215	MC1004	VCA-1001
W815/81	VO-27	W940/81	VO-1	MA1062	VFAP-7857	MA1150	VA-217	MC1005	VCA-1014
W815/82	VO-60	W940/9	VO-15	MA1064	VA-84	MA1151	VA-248	MC1006	VCA-1012
W816/80	VO-19	W940/99	VO-1	MA1065	VA-193	MA1152	VA-222	MC1006-2	VCA-1012
W817/80	VO-35	W950/16	VO-64	MA1066	VA-156	MA1155	VA-174	MC1007	VCA-1168
W818/4	VO-15	W950/18	VO-64	MA1068	VA-85	MA1156	VA-111	MC1008	VCA-1063
W818/8	VO-106	W950/4	VO-15	MA1069	VA-269	MA1157	VA-382	MC1009	VCA-1164
W818/81	VO-15	6750358366	VO-95	MA1070	VA-176	MA1158	VA-380	MC1009-2	VCA-1164
W818/82	VO-25	6750358426	VO-95	MA1071	VA-177	MA1175	VA-232	MC1010-2	VCA-1167
W818/84	VO-25	6750458346	VO-15	MA1072	VA-142	MA1183	VA-238	MC1011	VCA-1022
W818/98	VO-25	MANN & HUMMEL (MEXICO)		MA1073	VA-153	MA1184	VA-233	MC1012	VCA-1068
W818/99	VO-52	MA1000	VA-86	MA1074	VA-152	MA1185	VA-249	MC1013	VCA-1028
W822/99	VO-15	MA1001	VA-94	MA1075	VA-167	MA1186	VA-213	MC1014	VCA-1074
W830/1	VO-15	MA1002	VA-108	MA1076	VA-118	MA1187	VA-229	MC1015	VCA-1013
W840/2	VO-15	MA1003	VA-259	MA1077	VA-107	MA1188	VA-201	MC1016	VCA-1029
W9009	VO-170	MA1004	VA-2	MA1078	VA-192	MA1189	VA-202	MC1017	VCA-1067
W912	VO-95	MA1005	VA-69	MA1079	VA-88	MA1190	VA-212	MC1018	VCA-1163
W913	VO-95	MA1006	VA-65	MA1080	VA-144	MA1191	VA-231	MC1019	VCA-1157
W913/6	VO-95	MA1007	VA-90	MA1081	VA-103	MA1192	VA-210	MC1020	VCA-1014

CAUTION: For general references only. Check catalog for correct filter application. Any use of this interchange to determine filter application is done at the installers risk.
 PRECAUCION: Solamente para referencias generales. Revise el catálogo para la correcta aplicación del filtro. Cualquier uso de la referencia cruzada para determinar la aplicación del filtro es riesgo del instalador. ATTENTION : Seulement pour les références d'ordre général. Contrôler l'application correcte du filtre avec le catalogue. Toute utilisation de moyens afin de déterminer l'application d'un filtre est faite aux risques de l'installateur.

Cross Reference

Table da equivalencias da fabricantes

Code de renvoi au fabricant

MFR'S NUMBER	REPLACEMENT NUMBER	MFR'S NUMBER	REPLACEMENT NUMBER	MFR'S NUMBER	REPLACEMENT NUMBER	MFR'S NUMBER	REPLACEMENT NUMBER	MFR'S NUMBER	REPLACEMENT NUMBER
MANN & HUMMEL (MEXICO)									
MC1021	VCA-1170	ML1030	VO-88	G6Y0-14-302A	VO-106	ZZC4-23-802	VO-88	0000903751	VA-349
MC1022	VCA-1042	ML1031	VO-84	G6Y0-14-302ACA	VO-106	ZZL0-13-Z40	VA-66	0001801409	VO-1
MC1023	VCA-1122	ML1032	VO-69	HE19-23-802	VO-52	ZZL0-13-Z40ACA	VA-66	0001801509	VO-150
MC1042	VCA-1020	ML1033	VO-69	JEY0-14-302	VO-106	ZZL0-13-470	VG-32	0001802209	VO-69
MC1043	VCA-1030	ML1034	VO-81	JEY0-14-302A	VO-106	ZZL0-13-470A	VG-32	0001802309	VO-103
MC1044	VCA-1101	ML1035	VO-75	JEY0-14-302-9A	VO-106	ZZL0-14-302	VO-1	0001802309	VO-69
MC1046	VCA-1104	ML1036	VO-60	JE15-14-302	VO-106	ZZL0-14-302ACA	VO-1	0001802609	VO-103
MC1048	VCA-1129	ML1037	VO-90	JE48-13-Z40	VA-96	ZZM0-13-470	VG-16	0001802609	VO-69
MC1049	VCA-1037	ML1044	VO-67	JE48-13-Z40ACA	VA-96	ZZM0-13-470ACA	VG-16	0001803109	VO-103
MC1050	VCA-1051	ML1045	VO-87	JE48-13-Z409U	VA-96	ZZM0-23-802	VO-118	0001803109	VO-69
MC1051	VCA-1035	ML1046	VO-96	KD45-61-J6X	VCA-1175	ZZM1-23-802	VO-118	000182810	VO-106
MC1052	VCA-1031	ML1047	VO-81	KF1113Z40	VA-106	ZZM1-23-802ACA	VO-118	0008034V001	VO-120
MC1054	VCA-1031	ML1048	VO-102	KJ01-13-Z40	VFAP-7892	ZZM2-23-603	VA-114	0011849125	VO-70
MC1055	VCA-1065	ML1049	VO-88	KL07-14-302A	VO-106	ZZM2-23-603ACA	VA-114	0011849425	VO-69
MC1056	VCA-2033	ML1050	VO-99	KL47-13-Z40	VA-104	ZZN1-23-302	VO-118	0030947504	VA-380
MC1057	VCA-1043	ML1051	VO-109	KL47-13-Z40ACA	VA-104	ZZP0-23-603	VA-260	0030948204	VA-380
MC1058	VCA-1066	ML1052	VO-78	KL47-13-Z409A	VA-104	Z6Y1-14-302A	VO-106	1021840001	VO-15
MC1059	VCA-1031	ML1053	VO-98	LC74-61-P11	VCA-1014	Z622-13-Z40	VA-319	1021840101	VO-15
MC1060	VCA-1059	MAZDA		LDY4-61-J6X	VCA-1089	0000-23-0370	VO-106	1021840201	VO-15
MC1061	VCA-1044	AJTM-14-302	VO-88	LFG1-13-Z40	VA-362	0000-23-8173	VO-52	1021840301	VO-15
MC1063	VCA-1052	AJ03-13-480	VG-16	LF05-14-302A	VO-25	0324-14-300	VO-19	1021840501	VO-15
MC1065	VCA-1110	AJ04-14-302A	VO-88	LF10-14-302	VO-25	0324-23-802	VO-106	1031840001	VO-15
MC1067-2	VCA-1070	AJ04-14-302B	VO-88	LF24-61-P11	VCA-1049	0370-23-802	VO-106	1041800109	VO-62
MC1069	VCA-1034	AJ57-13-Z40	VA-194	LF50-13-Z40A	VA-207	0370-23-803	VO-52	1041840225	VO-62
MC1070	VCA-1114	AJ57-13-Z40-9U	VA-194	LF50-13Z-409U	VA-207	0813-23-802A	VO-52	1041840325	VO-62
MC1072	VCA-1038	AJ57-14-302	VO-88	L2Y6-61-P11	VCA-1049	0813-23-802B	VO-52	1041840425	VO-62
MC1074	VCA-1046	AM01-14-300	VO-106	L206-61-P11	VCA-1049	0837-23-672	VA-321	1041840825	VO-62
MC1075	VCA-1133	AM15-14-302	VO-19	L321-14-302	VO-80	0839-14-300	VO-52	1041840925	VO-62
MC1077	VCA-1055	AY01-14-302	VO-40	L321-14-3029U	VO-80	0839-23-672	VA-321	1111840225	VO-62
MC1078	VCA-1061	BBM4-61-J6X	VCA-1094	L518-13-Z40A	VA-215	0866-23-802	VO-52	1120940004	VA-132
MC1079	VCA-1050	BBY1-14-302A	VO-106	MB6M6-14-302	VO-106	0866-23-803	VO-52	1120940304	VA-400
MC1080	VCA-1047	BP4K-61-J6X	VCA-1046	N231-23-802	VO-106	1A50-13-Z40	VA-144	1120940604	VA-132
MC1081	VCA-1041	BP8P-61-J6X	VCA-1046	N3H1-13-Z40	VA-330	1E07-14302	VO-118	1121800009	VO-69
MC1083	VCA-1044	B359-14-302	VO-106	N3H1-13-Z409U	VA-330	1F70-23-603	VA-322	1121840025	VO-69
MC1261	VCA-1044	B595-13-Z40	VFAP-7893	N3R1-14-302	VO-106	1N00-13-Z40	VA-86	1121840225	VO-69
MF1000	VG-14	B595-13-Z40ACA	VFAP-7893	N3Y6-14-302	VO-106	1N00-14-302	VO-25	1121840425	VO-69
MF1001	VG-33	B595-13-Z409A	VFAP-7893	N350-14-302	VO-106	1N03-13-Z40	VA-86	1121840525	VO-69
MF1002	VG-16	B6MW-13-Z40	VA-397	PE01-14-302	VO-106	1N03-14-302	VO-106	1121840625	VO-69
MF1004	VG-32	B6MW-13-Z40CA	VA-397	PE01-14-302A	VO-106	1N05-13-Z40	VA-86	11218440425	VO-69
MF1008	VG-30	B6S7-13-Z40	VA-416	PE01-14-302B	VO-106	1N05-14-302	VO-25	1191800009	VO-70
ML1000	VO-16	B6Y0-14-300	VO-106	PE07-13-3A0A	VA-302	1N08-14-302	VO-106	1248300118	VCA-1058
ML1001	VO-95	B6Y0-14-302	VO-106	PY8W-14-302	VO-106	1WPE-14-302	VO-106	13718507320	VA-450
ML1002	VO-106	B6Y1-14-302A	VO-106	RFY2-14-302	VO-106	1665-23-672	VA-321	1601800310	VO-120
ML1003	VO-25	B6Y1-14-302A	VO-106	RF01-23-802	VO-106	1757-23-672	VA-321	1601840025	VO-120
ML1004	VO-1	B6Y2-14-302	VO-106	RF01-23-802A	VO-106	2113-23-672	VA-321	1601840225	VO-120
ML1005	VO-118	B6Y2-14-302A	VO-106	RF03-23-802	VO-106	3032-41-4300	VO-106	2038300118	VCA-1106
ML1006	VO-88	B6Y2-14-3029A	VO-106	RF03-23-802A	VO-106	37023802	VO-106	2038300518	VCA-1126
ML1007	VO-55	B630-14-302	VO-106	RF2A-13-Z40A	VA-190	4899-14-300	VO-52	2038300918	VCA-1106
ML1008	VO-106	B631-14-302	VO-106	RF2A-13-Z409U	VA-190	8172-23-802	VO-19	2038302118	VCA-1126
ML1009	VO-40	CA02-14-302	VO-118	RF2A-14-302	VO-106	8173-23-802	VO-52	2048300018	VCA-1153
ML1010	VO-108	CA02-14-302A	VO-118	RF4A-13-Z40	VA-190	8341-23-672	VA-321	2048300518	VCA-1153
ML1011	VO-56	CC29-61-J6X	VCA-1046	RF42-14-302	VO-106	MERCEDES-BENZ			
ML1012	VO-25	CE49-61-J6X	VCA-1046	RF79-14-302	VO-106	A0000902651	VA-349	2128300018	VCA-1153
ML1013	VO-58	CY01-13-Z40A	VA-224	TK48-61-J6X	VCA-2035	A0000903751	VA-349	2128300218	VCA-1153
ML1014	VO-106	D651-61-J6X	VCA-1098	VSY1-14-302	VO-136	A0001802609	VO-69	2128300318	VCA-1153
ML1015	VO-76	EG21-61-P11	VCA-1064	VSY3-14-302	VO-136	A001802810	VO-106	2700940004	VA-449
ML1016	VO-65	FEY0-14-302	VO-106	VS01-14-302	VO-136	A2038300018	VCA-1106	2701800009	VO-164
ML1017	VO-40	FSD7-13-Z40	VA-136	VS01-14-302A	VO-136	A2038300918	VCA-1106	2701800109	VO-164
ML1018	VO-106	FS05-13-Z40	VA-397	WLY4-14-302	VO-25	A2700940004	VA-449	2701840025	VO-164
ML1019	VO-80	FS05-13-Z409U	VA-397	YF09-13-Z40	VA-149	A2701800009	VO-164	2701840125	VO-164
ML1020	VO-63	FS11-13-Z40	VA-106	YF09-13-Z40CA	VA-149	A2701800109	VO-164	2710940304	VA-435
ML1021	VO-86	F2Y0-14-302	VO-106	YF09-14-302	VO-118	A2701840025	VO-164	2711800309	VO-151
ML1022	VO-118	F2Y0-14-302ACA	VO-106	YF09-14-302A	VO-118	A2701840125	VO-164	2711800409	VO-151
ML1023	VO-64	F802-23-802	VO-106	Y642-13-Z40B	VA-288	A2711800309	VO-151	2711800425	VO-151
ML1024	VO-15	GJ6A-61-P11	VCA-1064	Y645-13-Z40A	VA-284	A2711800409	VO-151	2711800509	VO-151
ML1025	VO-19	GJ6B-61-P11	VCA-1064	ZJ01-13-Z40	VA-319	A2711800509	VO-151	2711840325	VO-151
ML1026	VO-65	GK3J-61-148	VCA-1070	ZZCA-23-603	VA-249	A6111800009	VO-69	2711840425	VO-151
ML1027	VO-25	GS3L-61-148	VCA-1116	ZZCA-23-802	VO-80	A6421800009	VO-129	2730940404	Requires 2 VA-132
ML1028	VO-73	GY01-14-302B	VO-88	ZZCA-61-J6X	VCA-1104	A6421840025	VO-129	2760940004	VA-442
ML1029	VO-35	GY10-14-302CCA	VO-88	ZZC1-13-480	VG-32	A9068300218	VCA-1142	2761800009	VO-149
		G6Y0-14-302	VO-88	ZZC4-23-603	VA-246	0000902651	VA-349	2780940004	VA-452

CAUTION: For general references only. Check catalog for correct filter application. Any use of this interchange to determine filter application is done at the installers risk.

PRECAUCION: Solamente para referencias generales. Revise el catálogo para la correcta aplicación del filtro. Cualquier uso de la referencia cruzada para determinar la aplicación del filtro es riesgo del instalador. ATTENTION : Seulement pour les références d'ordre général. Contrôler l'application correcte du filtre avec le catalogue. Toute utilisation de moyens afin de déterminer l'application d'un filtre est faite aux risques de l'installateur.

Cross Reference

Table da equivalencias da fabricantes

Code de renvoi au fabricant

MFR'S NUMBER	REPLACEMENT NUMBER	MFR'S NUMBER	REPLACEMENT NUMBER	MFR'S NUMBER	REPLACEMENT NUMBER	MFR'S NUMBER	REPLACEMENT NUMBER	MFR'S NUMBER	REPLACEMENT NUMBER
MERCEDES-BENZ									
3094830467	VA-380	MGA3492	VA-45	MGA49730	VA-285	MGA8133	VA-117	MGA9902	VA-188
6111800009	VO-69	MGA3501	VA-411	MGA49737	VA-286	MGA8141	VFA-1641	MGA9944	VA-197
6111800967	VO-69	MGA3559	VA-40	MGA49739	VA-296	MGA8142	VFAP-1643	MGA9948	VA-269
6131800009	VO-137	MGA3588	VA-38	MGA49746	VA-293	MGA8162	VA-131	MGA9969	VA-203
6131800025	VO-137	MGA3647	VA-44	MGA49750	VA-304	MGA8205	VA-129	MGA9997	VA-198
6420940204	VA-371	MGA3660	VA-69	MGA49756	VA-273	MGA8208	VA-153	MGL10010	VO-114
6420940304	VA-371	MGA3901	VA-90	MGA49883	VA-223	MGA8221	VA-91	MGL10024	VO-117
6420940404	VA-371	MGA3902	VA-85	MGA49886	VA-239	MGA8243	VA-260	MGL10050	VO-115
6420942004	VA-371	MGA3914	VFAP-917	MGA49888	VA-373	MGA8475	VA-118	MGL10060	VO-88
6420942104	VA-371	MGA3916	VA-65	MGA49894	VA-254	MGA8547	VA-136	MGL10075	VO-91
6420942204	VA-371	MGA42188	VA-196	MGA5034	VA-2	MGA8548	VA-178	MGL10158	VO-87
6421800009	VO-129	MGA42295	VA-157	MGA5056	VA-205	MGA8602	VA-138	MGL10164	VO-109
6641800009	VO-69	MGA42341	VA-142	MGA5057	VA-413	MGA8606	VA-116	MGL10246	VO-98
68066165AA	VA-349	MGA42472	VA-138	MGA5058	VA-66	MGA8613	VA-159	MGL10255	VO-88
9068300218	VCA-1142	MGA42487	VA-259	MGA5125	VA-414	MGA8747	VA-156	MGL10295	VO-96
MICROGARD									
MGA10008	VA-303	MGA42564	VA-165	MGA5350	VFAP-7865	MGA8754	VA-78	MGL10358	VO-102
MGA10013	VA-202	MGA42793	VA-149	MGA5466	VFAP-7892	MGA8755A	VA-259	MGL10515	VO-99
MGA10014	VA-200	MGA42831	VA-188	MGA5595	VFAP-7893	MGA8760	VA-270	MGL10575	VO-88
MGA10015	VA-210	MGA42843	VA-180	MGA6366	VA-70	MGA8766	VA-152	MGL10600	VO-101
MGA10083	VA-228	MGA42859	VA-204	MGA6395	VA-84	MGA8768	VA-132	MGL10855	VO-109
MGA10084	VA-227	MGA4309	VA-86	MGA6479	VA-78	MGA8805	VA-137	MGL10955	VO-110
MGA10085	VA-226	MGA46153	VA-78	MGA6555	VA-88	MGA8817	VA-164	MGL16	VO-95
MGA10086	VA-208	MGA46253	VA-260	MGA6626	VA-269	MGA8911	VA-165	MGL16	VO-95
MGA10088	VA-201	MGA46302	VA-109	MGA6690	VA-401	MGA8918	VA-146	MGL2	VO-88
MGA10092	VA-216	MGA46320	VFAP-7865	MGA6690	VA-96	MGA8922	VA-190	MGL2870A	VO-15
MGA10093	VA-217	MGA46388	VA-135	MGA6807	VA-83	MGA8956	VA-142	MGL3387A	VO-16
MGA10094	VA-215	MGA46398	VA-338	MGA6821	VA-158	MGA8969	VA-140	MGL3506	VO-108
MGA10110	VA-225	MGA46440	VA-92	MGA6828	VA-416	MGA8970	VA-166	MGL3506	VO-58
MGA10118	VA-229	MGA46444	VA-118	MGA6850	VA-97	MGA8997	VA-149	MGL3531	VO-27
MGA10159	VA-251	MGA46573	VA-169	MGA6900	VA-261	MGA9007	VFAP-7865	MGL3569	VO-15
MGA10161	VA-218	MGA46673	VA-163	MGA7094	VA-101	MGA9053	VA-155	MGL3600	VO-118
MGA10163	VA-248	MGA46802	VA-192	MGA7142	VA-99	MGA9054	VA-154	MGL3614	VO-25
MGA10165	VA-212	MGA46804	VA-182	MGA7167	VA-98	MGA9073	VA-333	MGL3682	VO-25
MGA10169	VA-209	MGA46831	VA-183	MGA7174	VA-103	MGA9113	VA-150	MGL3766	VO-46
MGA10171	VA-214	MGA46832	VA-184	MGA7251	VA-102	MGA9115	VA-191	MGL3786	VO-63
MGA10173	VA-222	MGA46834	VA-171	MGA7344	VA-104	MGA9269	VA-169	MGL3950	VO-19
MGA10190	VA-231	MGA46924	VA-197	MGA7351	VA-102	MGA9286	VA-151	MGL3970	VO-37
MGA10191	VA-243	MGA46935	VA-224	MGA7365	VA-404	MGA9332	VA-162	MGL3976A	VO-64
MGA10192	VA-213	MGA49009	VA-291	MGA7365	VFAP-7854	MGA9345	VA-161	MGL3980	VO-55
MGA10228	VA-232	MGA49031	VA-274	MGA7414	VA-107	MGA9359	VA-170	MGL3985	VO-35
MGA10234	VA-244	MGA49033	VA-292	MGA7417	VFAP-7859	MGA9360	VA-163	MGL4681	VO-15
MGA10242	VA-224	MGA49041	VA-220	MGA7420	VA-113	MGA9361	VA-192	MGL4967	VO-40
MGA10254	VA-356	MGA49043	VA-313	MGA7421	VA-108	MGA9392	VA-193	MGL51036	VO-55
MGA10255	VA-424	MGA49049	VA-287	MGA7426	VA-106	MGA9400	VA-167	MGL51040	VO-16
MGA10262	VA-223	MGA49053	VA-216	MGA7431	VA-124	MGA9401	VA-160	MGL51042	VO-58
MGA10268	VA-453	MGA49057	VA-233	MGA7432	VA-112	MGA9409	VA-325	MGL51060	VO-56
MGA10270	VA-239	MGA49063	VA-184	MGA7438	VA-93	MGA9441	VA-172	MGL51069	VO-65
MGA10271	VA-230	MGA49067	VA-213	MGA7440	VA-105	MGA9459	VA-335	MGL51085	VO-95
MGA10315	VA-430	MGA49073	VA-236	MGA7597	VA-109	MGA9481	VA-270	MGL51088	VO-15
MGA10343	VA-234	MGA49102	VA-200	MGA7598	VA-110	MGA9482	VA-171	MGL51145	VO-62
MGA10344	VA-252	MGA49115	VA-430	MGA7614	VA-120	MGA9492	VA-176	MGL51160	LC-834
MGA10346	VA-238	MGA49120	VA-237	MGA7626	VA-125	MGA9493	VA-196	MGL51186	VO-74
MGA10347	VA-289	MGA49123	VA-357	MGA7628	VFAP-7857	MGA9516	VA-174	MGL51191	VO-159
MGA10348	VA-258	MGA49143	VA-448	MGA7630	VA-387	MGA9525	VA-247	MGL51212	VO-150
MGA10349	VA-233	MGA49158	VA-296	MGA7640	VA-111	MGA9555	VA-185	MGL51223	LC-8170
MGA10464	VA-323	MGA49180	VA-247	MGA7651	VA-157	MGA9563	VA-322	MGL51226	VO-69
MGA10465	VA-255	MGA49185	VA-353	MGA7730	VA-89	MGA9564	VA-183	MGL51246	VO-70
MGA10467	VA-221	MGA49186	VA-226	MGA7737	VFAP-1613	MGA9589	VA-177	MGL51258	VO-108
MGA10468	VA-220	MGA49187	VA-249	MGA7738	VFAP-1612	MGA9600	VA-184	MGL51315	VO-118
MGA10470	VA-235	MGA49200	VA-294	MGA7764	VA-135	MGA9603	VA-175	MGL51334	VO-106
MGA10488	VA-241	MGA49223	VA-214	MGA7774	VA-114	MGA9662	VA-189	MGL51342	VO-15
MGA10539	VA-240	MGA49320	VA-257	MGA8037	VA-320	MGA9669	VA-194	MGL51348	VO-25
MGA10544	VA-332	MGA49339	VA-408	MGA8038	VA-92	MGA9681	VA-206	MGL51355	VO-93
MGA10755	VA-273	MGA49429	VA-219	MGA8039	VA-94	MGA9683	VA-195	MGL51358	VO-106
MGA10881	VA-265	MGA49450	VA-265	MGA8040	VFAP-7908	MGA9687	VA-182	MGL51361	VO-15
MGA160	VA-321	MGA49498	VA-263	MGA8067	VFAP-7859	MGA9711	VA-274	MGL51361	VO-25
MGA192	VA-402	MGA49500	VA-297	MGA8069	VA-144	MGA9762	VA-179	MGL51365	VO-106
MGA326	VA-2	MGA49590	VA-426	MGA8080	VA-157	MGA9778	VA-181	MGL51372	VO-88
MGA327	VA-403	MGA49610	VA-390	MGA8121	VA-147	MGA9838	VA-180	MGL51378	VO-60
		MGA49634	VA-225	MGA8127	VA-208	MGA9895	VA-186	MGL51381	VO-19
		MGA49727	VA-255	MGA8127	VA-412	MGA9898	VA-207	MGL51392	VO-27

CAUTION: For general references only. Check catalog for correct filter application. Any use of this interchange to determine filter application is done at the installers risk.
 PRECAUCION: Solamente para referencias generales. Revise el catálogo para la correcta aplicación del filtro. Cualquier uso de la referencia cruzada para determinar la aplicación del filtro es riesgo del instalador. ATTENTION : Seulement pour les références d'ordre général. Contrôler l'application correcte du filtre avec le catalogue. Toute utilisation de moyens afin de déterminer l'application d'un filtre est faite aux risques de l'installateur.

Cross Reference

Table da equivalencias da fabricantes

Code de renvoi au fabricant

MFR'S NUMBER	REPLACEMENT NUMBER	MFR'S NUMBER	REPLACEMENT NUMBER	MFR'S NUMBER	REPLACEMENT NUMBER	MFR'S NUMBER	REPLACEMENT NUMBER	MFR'S NUMBER	REPLACEMENT NUMBER
MICROGARD		MGL9018	VO-76	A1518	VA-271	A3173	VA-280	A3961	VA-330
MGL51393	VO-15	MGL9100	VO-75	A1520	VA-324	A3174	VA-308	A3963	VA-386
MGL51394	VO-40	MGL9549	VO-81	A1624	VA-181	A3178	VA-457	A3974	VA-207
MGL51515	VO-1	MGL9641	VO-80	A1646	VA-174	A3216	VA-183	A3975	VA-188
MGL51516	VO-118	MGL9688	VO-106	A1679	VA-142	A3217	VA-373	A3977	VA-377
MGL51521	VO-95	MGL9911	VO-85	A1688	VA-140	A3218	VA-364	A3981	VA-340
MGL51522	VO-108	MGL9954	VO-85	A1695	VA-162	A3219	VA-316	A3982	VA-314
MGL51626	VO-35	MGL9972	VO-84	A1696	VA-149	A3220	VA-447	A3983	VA-251
MGL51630	VO-37	MGL9999	VO-90	A1744	VA-322	A3245	VA-184	A3984	VA-198
MGL51734	VO-63	3011	VCA-1002	A1745	VA-205	A34715	VA-99	A3991	VA-379
MGL51742	VO-46	3018	VCA-1122	A1746	VA-293	A34717	VA-98	A3992	VA-202
MGL5618	VO-86	3021A	VCA-1165	A1754	VA-182	A34721	VFAP-7859	A3993	VA-208
MGL57021	VO-66	3041	VCA-1014	A1756	VA-273	A34799	VA-103	A3994	VA-248
MGL57029	VO-99	3047	VCA-1063	A1757	VA-290	A34838	VA-132	A3996	VA-209
MGL57033	VO-73	3063	VCA-1068	A1890	VA-241	A34839	VA-387	A3997	VA-356
MGL57045	VO-88	3064	VCA-2033	A192	VA-402	A34852	VFAP-917	A3998	VA-289
MGL57047	VO-84	3670	VCA-1066	A2014	VA-161	A34877	VA-89	A3999	VA-226
MGL57055	VO-106	3672	VCA-1041	A2340	VA-175	A34878	VA-94	A4	VA-321
MGL57059	VO-149	3673	VCA-1047	A24278	VA-86	A34879	VA-114	A4000	VA-227
MGL57060	VO-88	3682	VCA-1110	A2441	VA-247	A34883	VA-412	A4001	VA-228
MGL57061	VO-90	3684	VCA-1031	A2442	VA-352	A34886	VA-125	A4002	VA-210
MGL57062	VO-129	3687	VCA-1046	A24675	VA-261	A3492	VA-45	A4003	VA-201
MGL57064	VO-102	3692	VCA-1069	A24716	VA-401	A34995	VA-124	A4004	VA-353
MGL57078	VO-103	3693	VCA-1146	A24720	VA-104	A3501	VA-411	A4006	VA-362
MGL57079	VO-78	3696	VCA-1044	A24807	VA-370	A35050	VA-128	A4007	VA-211
MGL57082	VO-76	3699	VCA-1138	A24819	VA-107	A35108	VFAP-7912	A4008	VA-212
MGL57083	VO-77	3701	VCA-1035	A24831	VFAP-7857	A35150	VA-135	A4009	VA-374
MGL57090	VO-67	3702	VCA-1104	A24858	VFAP-1612	A35155	VFAP-1643	A4010	VA-282
MGL57092	VO-106	3703	VCA-1051	A24859	VFAP-1613	A35192	VA-260	A4011	VA-213
MGL57145	VO-40	3704	VCA-1144	A24873	VA-113	A35219	VA-144	A4012	VA-229
MGL57151	VO-104	3705	VCA-1070	A24880	VA-109	A35227	VA-91	A4015	VA-231
MGL57173	VO-87	3708	VCA-1147	A24881	VA-110	A35244	VA-153	A4016	VA-230
MGL57175	VO-112	3710	VCA-1103	A25042	VA-93	A35265	VA-116	A4017	VA-214
MGL57186	VO-85	3712	VCA-1069	A25043	VA-120	A35267	VA-138	A4019	VA-242
MGL57187	VO-85	3713	VCA-1052	A25048	VA-112	A35272	VA-410	A4020	VA-343
MGL57202	VO-75	3718	VCA-1034	A25049	VFAP-7893	A3559	VA-40	A4021	VA-240
MGL57203	VO-80	3728	VCA-1036	A25089	VA-129	A35694	VA-371	A4022	VA-243
MGL57204	VO-92	3961	VCA-1043	A25148	VFAP-7908	A3588	VA-38	A4023	VA-244
MGL57210	VO-71	4006	VCA-1022	A25248	VA-117	A3589	VA-185	A4025	VA-258
MGL57211	VO-127	4013	VCA-1059	A25249	VA-118	A3590	VA-160	A4026	VA-232
MGL57250	VO-99	4015	VCA-1076	A25257	VA-136	A3592	VA-237	A4027	VA-252
MGL57303	VO-82	4016	VCA-1094	A2548	VA-342	A3593	VA-413	A4028	VA-357
MGL57311	VO-81	4017	VCA-1116	A26067	VFA-1641	A3594	VA-176	A4029	VA-238
MGL57327	VO-91	4018	VCA-1118	A26139	VA-391	A3595	VA-171	A4030	VA-233
MGL57341	VO-116	4021	VCA-1072	A2771	VA-197	A3598	VA-186	A4031	VA-234
MGL57356	VO-106	4023	VCA-1098	A2780	VA-222	A3601	VA-249	A4033	VA-235
MGL57462	VO-133	4025	VCA-1078C	A2782	VA-382	A3604	VA-326	A4034	VA-278
MGL57502	VO-88	4028	VCA-1171	A2785	VA-215	A3605	VA-313	A4035	VA-372
MGL57512	VO-111	4029	VCA-1115	A2786	VA-216	A3647	VA-44	A4038	VA-332
MGL57526	VO-110	4031	VCA-1073	A2883	VA-223	A3648	VA-310	A4042	VA-236
MGL57561	VO-101	4036	VCA-1071	A2884	VA-224	A3660	VA-69	A4043	VA-351
MGL57620	VO-64	4037	VCA-1177	A2886	VA-239	A3895	VA-194	A4044	VA-221
MGL57674	VO-98	4043	VCA-1080	A2893	VA-246	A3896	VA-274	A4045	VA-220
MGL57712	VO-106	4046	VCA-1077	A2944	VA-336	A3897	VA-318	A4048	VA-245
MGL57806	VO-97	4048	VCA-1081	A2947	VA-218	A3898	VA-329	A4049	VA-375
MGL57899	VO-88	4062	VCA-1183	A2956	VA-203	A3899	VA-368	A4051	VA-294
MGL6607	VO-106	4071	VCA-1173	A2959	VA-381	A3904	VA-180	A4052	VA-383
MGL6848	VO-62	4079	VCA-1081	A2962	VA-200	A3905	VA-199	A4054	VA-384
MGL7317	VO-106	4081	VCA-1097	A3054	VA-217	A3906	VA-355	A4055	VA-250
MGL8A	VO-1	4083	VCA-1175	A3076	VA-360	A3916	VA-65	A4057	VA-358
MGL8081	LC-8170	4089	VCA-1181	A3083	VA-225	A3917	VA-444	A4058	VA-385
MGL8158	VO-150	4090	VCA-1178	A3095	VA-219	A3933	VA-204	A4061	VA-273
MGL8212	VO-60	MIGHTY		A3096	VA-263	A3935	VA-323	A4062	VA-268
MGL8316	VO-118	AF3591	VA-363	A3099	VA-388	A3936	VA-365	A4063	VA-366
MGL8481	VO-69	AF3965	VA-337	A3128	VA-254	A3938	VA-309	A4064	VA-378
MGL8530	VO-71	AF4006	VA-362	A3138	VA-255	A3954	VA-187	A4065	VA-257
MGL8712	VO-66	AF7883	VA-395	A3139	VA-296	A3956	VA-179	A4067	VA-275
MGL8765	VO-67	AF7949	VA-350	A3141C	VA-295	A3957	VA-328	A4342	VA-85
MGL8806	VO-73	AF7973	VA-341	A3145	VA-285	A3958	VA-206	A43558	VA-389
MGL8873	VO-65	AF7977	VA-361	A3148	VA-327	A3959	VA-195	A4361	VA-408
MGL8994	VO-93	AF7989	VA-347	A3171	VA-299	A3960	VA-359	A4372	VA-90

CAUTION: For general references only. Check catalog for correct filter application. Any use of this interchange to determine filter application is done at the installers risk.

PRECAUCION: Solamente para referencias generales. Revise el catálogo para la correcta aplicación del filtro. Cualquier uso de la referencia cruzada para determinar la aplicación del filtro es riesgo del instalador. ATTENTION : Seulement pour les références d'ordre général. Contrôler l'application correcte du filtre avec le catalogue. Toute utilisation de moyens afin de déterminer l'application d'un filtre est faite aux risques de l'installateur.

Cross Reference

Table da equivalencias da fabricantes

Code de renvoi au fabricant

MFR'S NUMBER	REPLACEMENT NUMBER	MFR'S NUMBER	REPLACEMENT NUMBER	MFR'S NUMBER	REPLACEMENT NUMBER	MFR'S NUMBER	REPLACEMENT NUMBER	MFR'S NUMBER	REPLACEMENT NUMBER
MIGHTY		A7953	VA-190	A90113	VA-324	CAF2023	VCA-1031	CAF2145	VCA-1122
A4378	VA-70	A7954	VA-151	A90115	VA-470	CAF2024	VCA-1031	CAF2146	VCA-1068
A4464	VA-158	A7958	VA-270	A90121	VA-462	CAF2026	VCA-1037	CAF2148C	VCA-1153
A4468	VA-84	A7959	VA-152	A90128	VA-463	CAF2033C	VCA-1108	CAF2150	VCA-1173
A44727	VA-105	A7964	VA-191	A90138	VA-469	CAF2036C	VCA-1078C	CAF2151	VCA-1176
A4479	VA-78	A7965	VA-150	A90139	VA-474	CAF2040C	VCA-1103	CAF2152	VCA-1175
A45047	VA-111	A7974	VA-166	A90141	VA-273	CAF2054	VCA-1036	CAF2155	VCA-1193
A45090	VA-92	A7975	VA-156	A90142	VA-500	CAF2058	VCA-1142	CAF2164	VCA-1186
A45091	VA-320	A7976	VA-346	A90143	VA-501	CAF2059	VCA-1049	CAF2165	VCA-1185
A45105	VFAP-7865	A7978	VA-399	A90145	VA-438	CAF2061	VCA-1104	CAF2167	VCA-1191
A45206	VA-148	A7981	VA-155	A9096	VA-167	CAF2062	VCA-1101	CAF2168	VCA-1178
A4601	VA-414	A7982	VA-172	A9098	VA-196	CAF2063	VCA-1138	CAF2169	VCA-1181
A4632	VA-88	A7983	VA-345	A91	VA-2	CAF2064	VCA-1051	CAF2170	VCA-1187
A4633	VA-269	A7984	VA-154	A92	VA-403	CAF2068	VCA-1144	CAF2174	VCA-1188
A4645	VA-96	A7985	VA-333	A9546	VA-335	CAF2069	VCA-1057	CAF2176	VCA-2043
A4648	VA-416	A7987	VA-132	CAF1700	VCA-1157	CAF2070	VCA-1050	CAF2177	VCA-1078C
A4650	VA-101	A7990	VA-165	CAF1702	VCA-1026	CAF2071	VCA-1072	CAF2182	VCA-2035
A4669	VA-97	A7991	VA-170	CAF1703	VCA-1001	CAF2072	VCA-1053	CAF2183	VCA-1195
A4680	VA-83	A7992	VA-279	CAF1704	VCA-1021	CAF2073	VCA-1046	CAF7757	VCA-1164
A4690	VA-102	A7996	VA-169	CAF1706	VCA-1002	CAF2074	VCA-1046	FB56	VA-48
A47039	VA-157	A7997	VA-400	CAF1707	VCA-1003	CAF2075	VCA-1062	FG14A	VG-2
A4712	VA-404	A7998	VA-192	CAF1708	VCA-1167	CAF2076	VCA-1064	FG800	VG-16
A4712	VFAP-7854	A7999	VA-193	CAF1713	VCA-1017	CAF2077	VCA-1070	FG872	VG-32
A4722	VFAP-7892	A81519	VA-259	CAF1716	VCA-1161	CAF2078	VCA-1049	GF481	VG-14
A4731	VA-108	A81680	VA-122	CAF1717	VCA-1123	CAF2078	VCA-1089	GF578	VG-33
A4832	VA-106	A8248	VA-147	CAF1720	VCA-1060	CAF2082	VCA-1110	GF580	VG-30
A4897	VA-253	A8777	VA-164	CAF1721	VCA-1162	CAF2083	VCA-1147	LAF8996	VA-380
A5056	VA-205	A8837	VA-264	CAF1722	VCA-1127	CAF2084	VCA-1061	M1	VO-1
A5058	VA-66	A88493	VA-325	CAF1726	VCA-1122	CAF2086	VCA-1041	M1009	VO-114
A5185	VA-265	A8996	VA-380	CAF1727	VCA-1106	CAF2087	VCA-1039	M1014	VO-142
A5186	VA-390	A90001	VA-392	CAF1739	VCA-1040	CAF2088	VCA-1044	M159	VO-108
A5187	VA-283	A90003	VA-334	CAF1742	VCA-1022	CAF2089	VCA-1044	M159	VO-108
A5191	VA-189	A90006	VA-446	CAF1743	VCA-1008	CAF2090	VCA-1038	M2008	VO-86
A5192	VA-319	A90007	VA-450	CAF1745	VCA-1125	CAF2091	VCA-1048	M2009	VO-86
A5196	VA-291	A90008	VA-424	CAF1747	VCA-1160	CAF2092	VCA-1159	M2017	VO-81
A5198	VA-286	A90011	VA-284	CAF1751	VCA-1042	CAF2093	VCA-1052	M2051	VO-104
A5200	VA-473	A90012	VA-419	CAF1754	VCA-1029	CAF2095	VCA-1034	M2129	VO-67
A5201	VA-292	A90014	VA-303	CAF1755	VCA-1020	CAF2096	VCA-1048	M2224	VO-73
A5206	VA-300	A90015	VA-434	CAF1756	VCA-1163	CAF2097	VCA-1171	M26	VO-88
A5207	VA-301	A90018	VA-437	CAF1758	VCA-1012	CAF2098	VCA-1082	M2870	VO-15
A5208	VA-297	A90020	VA-460	CAF1759	VCA-1131	CAF2103	VCA-1114	M289	VO-35
A5209	VA-426	A90025	VA-445	CAF1762	VCA-1030	CAF2104	VCA-1114	M2901	VO-15
A5210	VA-307	A90027	VA-442	CAF1764	VCA-1028	CAF2105	VCA-1145	M2902	VO-144
A5211	VA-302	A90028	VA-452	CAF1768	VCA-1058	CAF2110	VCA-1155	M2904	VO-95
A5217	VA-331	A90030	VA-344	CAF1770	VCA-1013	CAF2112	VCA-1134	M2905	VO-86
A5218	VA-393	A90036	VA-449	CAF1771	VCA-1024	CAF2113	VCA-1109	M2992	VO-124
A5220	VA-312	A90038	VA-453	CAF1774	VCA-1067	CAF2114	VCA-1030	M2999	VO-75
A5221	VA-427	A90040	VA-423	CAF1779	VCA-1043	CAF2115	VCA-1117	M3040	VO-77
A5222	VA-304	A90042	VA-435	CAF1781	VCA-1063	CAF2117	VCA-1061	M3244	VO-76
A5223	VA-305	A90046	VA-438	CAF1782	VCA-1129	CAF2122	VCA-1075	M33	VO-108
A5224	VA-311	A90048	VA-432	CAF1787	VCA-1056	CAF2124C	VCA-1080	M3387	VO-16
A54855	VA-338	A90052	VA-428	CAF1790	VCA-1065	CAF2125	VCA-1093	M3531	VO-27
A5848	VA-394	A90054	VA-440	CAF1792	VCA-1068	CAF2126	VCA-1059	M3600	VO-118
A5857	VA-159	A90055	VA-451	CAF1795	VCA-1156	CAF2127	VCA-1118	M3614	VO-25
A5980	VA-177	A90056	VA-430	CAF1796	VCA-1124	CAF2128	VCA-1177	M3682	VO-25
A6151	VA-287	A90058	VA-425	CAF2003	VCA-1166	CAF2129	VCA-1081	M3766	VO-46
A6900	VA-267	A90060	VA-418	CAF2004	VCA-1096	CAF2130	VCA-1073	M3968	VO-137
A6902	VA-266	A90065	VA-490	CAF2005	VCA-2033	CAF2131	VCA-1077	M3969	VO-129
A6904	VA-284	A90066	VA-443	CAF2007C	VCA-1135	CAF2132	VCA-1071	M3970	VO-37
A6908	VA-288	A90072	VA-431	CAF2009	VCA-1102	CAF2133	VCA-1115	M3972	VO-130
A6910	VA-298	A90073	VA-466	CAF2010	VCA-1170	CAF2135	VCA-1076	M3980	VO-55
A6911	VA-429	A90075	VA-455	CAF2011	VCA-1014	CAF2136	VCA-1116	M3985	VO-19
A6912	VA-306	A90081	VA-417	CAF2012	VCA-1074	CAF2137	VCA-1094	M3986	VO-85
A7905	VA-131	A90087	VA-471	CAF2013	VCA-1113	CAF2138	VCA-1098	M3986OE	VO-85
A7937	VA-397	A90088	VA-458	CAF2014	VCA-1146	CAF2139	VCA-1174	M40A	VO-56
A7938	VA-146	A90096	VA-454	CAF2015	VCA-1066	CAF2140	VCA-1120	M4006	VO-58
A7939	VA-315	A90097	VA-464	CAF2016	VCA-1139	CAF2141	VCA-1097	M4422	VO-64
A7942	VA-354	A9010	VA-163	CAF2017	VCA-1139	CAF2142	VCA-1184	M4455	VO-106
A7943	VA-339	A90100	VA-456	CAF2018	VCA-1047	CAF2143	VCA-1183	M4456	VO-78
A7944	VA-178	A90103	VA-459	CAF2019	VCA-1054	CAF2143C	VCA-1183	M4460	VO-106
A7946	VA-137	A90105	VA-467	CAF2020	VCA-1035	CAF2144	VCA-1037	M4466	VO-15

CAUTION: For general references only. Check catalog for correct filter application. Any use of this interchange to determine filter application is done at the installers risk.
 PRECAUCION: Solamente para referencias generales. Revise el catálogo para la correcta aplicación del filtro. Cualquier uso de la referencia cruzada para determinar la aplicación del filtro es riesgo del instalador. ATTENTION : Seulement pour les références d'ordre général. Contrôler l'application correcte du filtre avec le catalogue. Toute utilisation de moyens afin de déterminer l'application d'un filtre est faite aux risques de l'installateur.

Cross Reference

Table da equivalencias da fabricantes

Code de renvoi au fabricant

MFR'S NUMBER	REPLACEMENT NUMBER	MFR'S NUMBER	REPLACEMENT NUMBER	MFR'S NUMBER	REPLACEMENT NUMBER	MFR'S NUMBER	REPLACEMENT NUMBER	MFR'S NUMBER	REPLACEMENT NUMBER
MIGHTY		M991	VO-116	MA3559	VA-40	MA8612	VA-339	MO3682	VO-25
M4477	VO-40	M995	VO-132	MA3588	VA-38	MA8613	VA-159	MO3786	VO-63
M4484	VO-60	M996	VO-121	MA3647	VA-44	MA8747	VA-156	MO3950	VO-19
M453	VO-93	M997	VO-151	MA3660	VA-69	MA8754	VA-78	MO3970	VO-37
M454	VO-65	PH2811	VO-19	MA3901	VA-90	MA8755	VA-271	MO3976	VO-64
M4612	VO-106	PH2892	VO-143	MA3902	VA-85	MA8755A	VA-271	MO3985	VO-35
M4615	VO-106	PH2903	VO-52	MA3914	VFAP-917	MA8756	VA-259	MO4967	VO-40
M4622	VO-106	P2923	VO-119	MA3916	VA-65	MA8805	VA-137	MO5	VO-56
M4651	VO-88	P3987	VO-139	MA4309	VA-86	MA8911	VA-165	MO5320	LC-834
M4675	VO-95	P838	VO-127	MA4939	VA-408	MA8922	VA-190	MO5343	VO-106
M4757	VO-62	P929	VO-128	MA5056	VA-205	MA8925	VA-122	MO6607	VO-106
M48	VO-88	MIGHTY MAX SYNTHETIC		MA5057	VA-413	MA8956	VA-142	MO6607	VO-106
M4872	VO-63	MX1	VO-1	MA5058	VA-66	MA8969	VA-140	MO8A	VO-1
M500	VO-88	MX1009	VO-114	MA5125	VA-414	MA8997	VA-149	MO8081	LC-8170
M5230	VO-118	MX1014	VO-142	MA5466	VFAP-7892	MA9007	VFAP-7865	MO8212	VO-60
M5964	VO-161	MX159	VO-108	MA5595	VFAP-7893	MA9053	VA-155	MO8481	VO-103
M610	VO-101	MX2017	VO-81	MA6366	VA-70	MA9054	VA-154	MO8481	VO-69
M734	VO-162	MX2129	VO-67	MA6395	VA-84	MA9055	VA-345	MO8712	VO-66
M8153	VO-69	MX2870	VO-15	MA6479	VA-78	MA9073	VA-333	MO8765	VO-67
M8153OE	VO-69	MX3244	VO-76	MA6555	VA-88	MA9113	VA-150	MO8806	VO-73
M8170	LC-8170	MX3387	VO-16	MA6626	VA-269	MA9115	VA-191	MO8873	VO-65
M8198	VO-74	MX3600	VO-118	MA6690	VA-96	MA9269	VA-169	MO9010	VO-86
M8198OE	VO-74	MX3614	VO-25	MA6807	VA-83	MA9277	VA-346	MO9018	VO-76
M833	LC-833	MX3980	VO-55	MA6828	VA-416	MA9286	VA-151	MO9100	VO-75
M837	VO-66	MX40A	VO-56	MA6850	VA-97	MA9332	VA-162	MO9447	VO-78
M837OE	VO-66	MX4006	VO-58	MA7094	VA-101	MA9345	VA-161	MO9549	VO-81
M842	VO-97	MX4477	VO-40	MA7142	VA-99	MA9359	VA-170	MO9688	VO-106
M8445	LC-8445	MX454	VO-65	MA7167	VA-98	MA9360	VA-163	MO9688	VO-106
M845	VO-70	MX4612	VO-106	MA7174	VA-103	MA9361	VA-192	MO9688	VO-52
M846	VO-150	MX4615	VO-106	MA7344	VA-104	MA9400	VA-167	MO9972	VO-84
M846OE	VO-150	MX48	VO-88	MA7351	VA-102	MA9401	VA-160	mitsubishi	
M856	VO-71	MX500	VO-88	MA7365	VFAP-7854	MA9441	VA-172	AW340753	VA-99
M856OE	VO-71	MX8153	VO-103	MA7414	VA-107	MA9459	VA-335	AW343979	VO-106
M8812	LC-834	MX8170	LC-8170	MA7417	VFAP-7859	MA9481	VA-270	D001450	VO-19
M9001	VO-117	MX837	VO-66	MA7420	VA-113	MA9482	VA-171	F1230A114	VO-136
M9002	VO-153	MX842	VO-97	MA7421	VA-108	MA9492	VA-176	H3774046100	VO-162
M9004	VO-164	MX9001	VO-117	MA7426	VA-106	MA9493	VA-196	KL4713240	VA-104
M9007	VO-91	MX9012	VO-166	MA7431	VA-124	MA9501	VA-399	K466201	VO-19
M9008	VO-133	MX9015	VO-115	MA7432	VA-112	MA9516	VA-174	K4662010	VO-19
M9010	VO-174	MX9017	VO-167	MA7434	VA-124	MA9525	VA-247	K466201	VO-19
M9011	VO-139	MX9020	VO-172	MA7440	VA-105	MA95563	VA-322	K6662010	VO-19
M9012	VO-166	MX9021	VO-168	MA7597	VA-109	MA9564	VA-183	K9665400	VO-106
M9015	VO-115	MX9022	VO-164	MA7598	VA-110	MA9565	VA-328	MB134953	VO-106
M9016	VO-165	MX9025	VO-173	MA7600	VA-338	MA9589	VA-177	MB906051	VA-104
M9017	VO-167	MX9026	VO-169	MA7626	VA-125	MA9600	VA-184	MC031805	VO-19
M907	VO-138	MX9028	VO-117	MA7628	VFAP-7857	MA9603	VA-175	MC10863	VO-95
M929	VO-128	MX9032	VO-98	MA7640	VA-111	MA9662	VA-189	MD001445	VO-19
M9501	VO-25	MX929	VO-128	MA7730	VA-89	MA9669	VA-194	MD013661	VO-19
M9502	VO-123	MX9509	VO-200	MA7738	VFAP-1612	MA9683	VA-195	MD017440	VO-106
M9503	VO-170	MX960	VO-80	MA7764	VA-135	MA9687	VA-182	MD030795	VO-19
M9509	VO-200	MX962	VO-112	MA7774	VA-114	MA9762	VA-337	MD031805	VO-19
M960	VO-80	MX966	VO-92	MA8038	VA-92	MA9778	VA-181	MD05281090	VO-95
M961	VO-94	MX967	VO-84	MA8039	VA-94	MA9818	VA-146	MD069782	VO-136
M962	VO-112	MX969	VO-91	MA8040	VFAP-7908	MA9838	VA-180	MD069982	VO-52
M964	VO-82	MX972	VO-90	MA8067	VFAP-7859	MA9895	VA-186	MD071462	VO-19
M966	VO-92	MX978	VO-111	MA8069	VA-144	MA9902	VA-188	MD071462A	VO-19
M967	VO-84	MX980	VO-102	MA8133	VA-117	MA9944	VA-197	MD084693	VO-35
M968	VO-87	MX981	VO-98	MA8141	VFA-1641	MA9969	VA-203	MD097003	VO-106
M969	VO-91	MX982	VO-99	MA8142	VFAP-1643	MO10060	VO-88	MD108063	VO-25
M972	VO-90	MX985	VO-103	MA8162	VA-131	MO10060	VO-88	MD129809	VO-95
M978	VO-111	MX992	VO-149	MA8205	VA-129	MO10075	VO-91	MD134953	VO-106
M979	VO-96	MILEGUARD		MA8208	VA-153	MO16	VO-95	MD135737	VO-106
M980	VO-102	BA3525	VA-34	MA8221	VA-91	MO16	VO-95	MD136466	VO-106
M981	VO-98	BA3631	VA-48	MA8243	VA-260	MO2	VO-88	MD136790	VO-106
M982	VO-99	MA12051	VA-454	MA8269	VA-410	MO3387A	VO-16	MD162326	VO-106
M983	VO-140	MA160	VA-321	MA8475	VA-118	MO3387A	VO-55	MD184086	VO-136
M985	VO-103	MA192	VA-402	MA8547	VA-136	MO3506	VO-108	MD215002	VO-146
M986	VO-141	MA326	VA-2	MA8548	VA-178	MO3506	VO-58	MD308302	VO-25
M987	VO-131	MA327	VA-403	MA8602	VA-138	MO3600	VO-118	MD321589	VO-106
M989	VO-109	MA3492	VA-45	MA8606	VA-116	MO3600	VO-15	MD322508	VO-19
M990	VO-110	MA3501	VA-411	MA8609	VA-108	MO3614	VO-25	MD325714	VO-106

CAUTION: For general references only. Check catalog for correct filter application. Any use of this interchange to determine filter application is done at the installers risk.

PRECAUCION: Solamente para referencias generales. Revise el catálogo para la correcta aplicación del filtro. Cualquier uso de la referencia cruzada para determinar la aplicación del filtro es riesgo del instalador. ATTENTION : Seulement pour les références d'ordre général. Contrôler l'application correcte du filtre avec le catalogue. Toute utilisation de moyens afin de déterminer l'application d'un filtre est faite aux risques de l'installateur.

Cross Reference

Table da equivalencias da fabricantes

Code de renvoi au fabricant

MFR'S NUMBER	REPLACEMENT NUMBER	MFR'S NUMBER	REPLACEMENT NUMBER	MFR'S NUMBER	REPLACEMENT NUMBER	MFR'S NUMBER	REPLACEMENT NUMBER	MFR'S NUMBER	REPLACEMENT NUMBER
MITSUBISHI		30A4000100	VO-106	AF372	VA-414	AF5244	VA-417	CAF10004P	VCA-2055
MD326489	VO-136	30A4000103	VO-106	AF3897	VA-318	AF5245	VA-418	CAF10009P	VCA-2051
MD332678	VO-106	30A4000105	VO-106	AF3898	VA-329	AF5246	VA-431	CAF1700	VCA-1157
MD3326879	VO-106	30A4000201	VO-106	AF3905	VA-199	AF5248	VA-432	CAF1702	VCA-1026
MD352626	VO-106	30A4000205	VO-106	AF3906	VA-355	AF5251	VA-334	CAF1703	VCA-1001
MD352627	VO-106	3254011600	VO-163	AF3917	VA-444	AF5252	VA-485	CAF1704	VCA-1021
MD353795	VO-95	3254011600D	VO-163	AF3927	VA-443	AF5258	VA-455	CAF1708	VCA-1167
MD360935	VO-106	3414070100	VO-19	AF3933	VA-204	AF5259	VA-466	CAF1713	VCA-1017
MD620456	VA-99	3425046	VO-1	AF3955	VA-205	AF5263	VA-464	CAF1716	VCA-1161
MD620472	VA-99	4012520003	VO-19	AF3957	VA-328	AF5264	VA-454	CAF1717	VCA-1123
MD620596	VA-104	4063396	VO-19	AF3960	VA-359	AF5265	VA-465	CAF1720	VCA-1060
MD620737	VA-387	4243102	VO-19	AF3961	VA-330	AF5266	VA-456	CAF1721	VCA-1162
MD620823	VA-128	42820003	VO-19	AF3963	VA-386	AF5271	VA-461	CAF1722	VCA-1127
MD620837	VA-128	7803A004	VCA-1068	AF3977	VA-377	AF5273	VA-470	CAF1726	VCA-1122
MD906051	VA-110	7803A109	VCA-1068	AF3981	VA-340	AF5277	VA-499	CAF1730	VCA-1039
ME013307	VO-146	9042000460	VO-55	AF3982	VA-314	AF5286	VA-500	CAF1739	VCA-1040
ME013343	VO-146	91H2011870	VO-25	AF3991	VA-379	AF5293	VA-498	CAF1742K	VCA-1022K
ME013661	VO-19	9122000500	VO-19	AF3994	VA-248	AF5296	VA-497	CAF1745	VCA-1125
ME031805	VO-19	9122000550	VO-19	AF3997	VA-356	AF56	VA-48	CAF1747	VCA-1160
ME034878	VO-163	9122010500	VO-19	AF4006	VA-362	AF5694	VA-371	CAF1749	VCA-1010
ME084530	VO-163	MOBIL		AF4007	VA-211	AF5696	VA-452	CAF1751	VCA-1042
ME088519	VO-163	AF10025	VA-502	AF4009	VA-374	AF5698	VA-435	CAF1754	VCA-1029
ME201871	VO-136	AF10031	VA-503	AF4028	VA-357	AF5699	VA-442	CAF1755	VCA-1020
ME202472	VO-146	AF10032	VA-504	AF4043	VA-351	AF5703	VA-449	CAF1756	VCA-1163
ME215002	VO-146	AF1042	VA-413	AF4049	VA-375	AF5848	VA-394	CAF1765	VCA-1037
MK666096	VO-170	AF1061	VA-88	AF4051	VA-294	AF5857	VA-159	CAF1767	VCA-1106
MK667378	VO-170	AF1236	VA-412	AF4055	VA-250	AF602	VA-40	CAF1768	VCA-1058
MM409365	VO-106	AF1301	VA-320	AF4057	VA-358	AF6908	VA-288	CAF1770	VCA-1013
MN185231	VCA-1147	AF1518	VA-271	AF4058	VA-385	AF6910	VA-298	CAF1771	VCA-1024
MN980125	VO-77	AF1612	VFAP-1612	AF4062	VA-268	AF6928	VA-463	CAF1779	VCA-1043
MR127077	VA-90	AF1613	VFAP-1613	AF4063	VA-366	AF6935	VA-501	CAF1782	VCA-1129
MR127078	VA-90	AF1618	VA-120	AF4064	VA-378	AF697	VA-45	CAF1789	VCA-1056
MR188657	VA-153	AF1641	VFA-1641	AF4065	VA-257	AF7819	VA-401	CAF1795	VCA-1156
MR239024	VA-90	AF2340	VA-175	AF4067	VA-175	AF7825	VA-97	CAF1796	VCA-1124
MR258421	VA-153	AF2442	VA-352	AF4897	VA-253	AF7826	VA-416	CAF1797	VCA-1065
MR398288	VCA-1147	AF2548	VA-342	AF5185	VA-265	AF7827	VA-158	CAF1800C	VCA-1135
MR464177	VA-153	AF2780	VA-222	AF5186	VA-390	AF7828	VA-83	CAF1801P	VCA-1139
MR481794	VA-153	AF2782	VA-382	AF5187	VA-283	AF7831	VA-370	CAF1802P	VCA-1070
MR500360	VCA-1113	AF2944	VA-336	AF5189	VA-391	AF7832	VA-98	CAF1803C	VCA-1096
MR541473	VA-128	AF3076	VA-360	AF5192	VA-319	AF7842	VA-103	CAF1803P	VCA-1096
MR552951	VA-153	AF3099	VA-388	AF5196	VA-291	AF7849	VA-124	CAF1804P	VCA-1048
MR571396	VA-206	AF3128	VA-254	AF5197	VA-293	AF7861	VA-387	CAF1805C	VCA-2033
MR571471	VA-99	AF3139	VA-296	AF5198	VA-286	AF7875	VA-338	CAF1806P	VCA-1170
MR571473	VA-128	AF3171	VA-299	AF5199	VA-310	AF7876	VA-128	CAF1807P	VCA-1102
MR968274	VA-437	AF3174	VA-308	AF5200	VA-473	AF7883	VA-395	CAF1808P	VCA-1145
MZ311783	VA-99	AF3178	VA-457	AF5201	VA-292	AF7885	VFAP-7865	CAF1809P	VCA-1134
MZ311784	VA-387	AF3184	VA-424	AF5205	VA-287	AF7905	VA-131	CAF1810C	VCA-1103
MZ312931	VCA-1014	AF3195	VA-425	AF5206	VA-300	AF7907	VA-148	CAF1810P	VCA-1103
MZ690071	VO-136	AF3201	VA-468	AF5207	VA-301	AF7912	VFAP-7912	CAF1811P	VCA-1172
MZ690072	VO-106	AF3202	VA-471	AF5208	VA-297	AF7918	VA-136	CAF1812C	VCA-1074
MZ690115	VO-106	AF3208	VA-459	AF5209	VA-426	AF7922	VA-396	CAF1812P	VCA-1169
MZ690116	VO-106	AF3212	VA-467	AF5210	VA-307	AF7937	VA-397	CAF1813P	VCA-1041
MZ690116	VO-106	AF3218	VA-364	AF5211	VA-302	AF7942	VA-354	CAF1814P	VCA-1035
MZ690150	VO-106	AF3219	VA-316	AF5212	VA-445	AF7943	VA-339	CAF1815P	VCA-1044
MZ690361	VCA-1147	AF3220	VA-447	AF5213	VA-392	AF7944	VA-178	CAF1817P	VCA-1075
MZ690411	VO-136	AF3226	VA-474	AF5216	VA-344	AF7949	VA-350	CAF1818P	VCA-1066
MZ690445	VA-278	AF329	VA-403	AF5217	VA-331	AF7964	VA-191	CAF1820P	VCA-1047
QY010015	VO-146	AF351	VA-84	AF5218	VA-393	AF7973	VA-341	CAF1821P	VCA-1113
Q1400001	VO-106	AF355	VA-389	AF5219	VA-303	AF7976	VA-346	CAF1823B	VCA-1101
SMD360935N	VO-106	AF3589	VA-185	AF5220	VA-312	AF7977	VA-361	CAF1825P	VCA-1138
XD00145	VO-19	AF359	VA-408	AF5221	VA-427	AF7978	VA-399	CAF1829P	VCA-1159
XD031805	VO-19	AF3591	VA-363	AF5222	VA-304	AF7983	VA-345	CAF1830P	VCA-1146
XR127077	VA-90	AF3593	VA-325	AF5223	VA-305	AF7989	VA-347	CAF1832P	VCA-1155
1230A045	VO-136	AF3604	VA-326	AF5224	VA-311	AF7992	VA-279	CAF1834P	VCA-1089
1230A046	VO-146	AF3605	VA-313	AF5225	VA-460	AF7997	VA-400	CAF1835P	VCA-1054
1230A114	VO-136	AF3609	VA-446	AF5230	VA-419	AF89	VA-34	CAF1839P	VCA-1046
1230A152	VO-106	AF3612	VA-290	AF5231	VA-437	AF925	VA-85	CAF1840C	VCA-1108
1230A154	VO-146	AF3617	VA-423	AF5233	VA-434	AF9911	VA-429	CAF1840P	VCA-1158
1500A023	VA-278	AF3618	VA-450	AF5235	VA-438	AF9912	VA-306	CAF1844P	VCA-1104
1500A086	VA-278	AF3621	VA-453	AF5239	VA-428	AF9916	VA-451	CAF1845P	VCA-1069
1500A513	VA-437	AF3626	VA-488	AF5240	VA-440	AF9918	VA-430	CAF1846P	VCA-1051

CAUTION: For general references only. Check catalog for correct filter application. Any use of this interchange to determine filter application is done at the installers risk.
 PRECAUCION: Solamente para referencias generales. Revise el catálogo para la correcta aplicación del filtro. Cualquier uso de la referencia cruzada para determinar la aplicación del filtro es riesgo del instalador. ATTENTION : Seulement pour les références d'ordre général. Contrôler l'application correcte du filtre avec le catalogue. Toute utilisation de moyens afin de déterminer l'application d'un filtre est faite aux risques de l'installateur.

Cross Reference

Table da equivalencias da fabricantes

Code de renvoi au fabricant

MFR'S NUMBER	REPLACEMENT NUMBER	MFR'S NUMBER	REPLACEMENT NUMBER	MFR'S NUMBER	REPLACEMENT NUMBER	MFR'S NUMBER	REPLACEMENT NUMBER	MFR'S NUMBER	REPLACEMENT NUMBER
MOBIL		CAF7767	VCA-1126	MA4019	VA-242	MA5305	VA-146	MCAF1742	VCA-1022
CAF1847P	VCA-1142	CAF7796	VCA-1124	MA4020	VA-343	MA5306	VA-137	MCAF1743	VCA-1008
CAF1848P	VCA-1038	CAF7799	VCA-1133	MA4021	VA-240	MA5314	VA-259	MCAF1758	VCA-1012
CAF1849P	VCA-1034	G16	VG-2	MA4022	VA-243	MA5323	VA-149	MCAF1762	VCA-1030
CAF1850P	VCA-1049	G481	VG-14	MA4023	VA-244	MA5324	VA-140	MCAF1764	VCA-1028
CAF1851P	VCA-1110	G578	VG-33	MA4025	VA-258	MA5353	VA-150	MCAF1766	VCA-1014
CAF1852P	VCA-1052	G580	VG-30	MA4026	VA-232	MA5359	VA-151	MCAF1774	VCA-1067
CAF1855P	VCA-1144	G6367	VG-32	MA4027	VA-252	MA5370	VA-190	MCAF1781	VCA-1063
CAF1857P	VCA-1194	G800	VG-16	MA4029	VA-238	MA5372	VA-156	MCAF1792	VCA-1068
CAF1861P	VCA-1036	LAF1520	VA-324	MA4030	VA-233	MA5373	VA-152	MCAF1816P	VCA-1031
CAF1862P	VCA-1050	LAF1617	VA-93	MA4031	VA-234	MA5378	VA-111	MO1A	VO-1
CAF1863P	VCA-1114	LAF1675	VA-410	MA4033	VA-235	MA5387	VA-172	MO1009	VO-114
CAF1864P	VCA-1064	LAF1680	VA-122	MA4034	VA-278	MA5395	VA-193	MO111	VO-16
CAF1865P	VCA-1053	LAF3231	VA-469	MA4035	VA-372	MA5396	VA-154	MO193	VO-19
CAF1866C	VCA-1153	LAF388	VA-411	MA4038	VA-332	MA5397	VA-165	MO2009	VO-86
CAF1867P	VCA-1062	LAF5980FP	VA-272	MA4042	VA-236	MA5398	VA-170	MO2009	VO-86
CAF1868P	VCA-1059	LAF6927	VA-462	MA4044	VA-221	MA5400	VA-169	MO2051	VO-104
CAF1869P	VCA-1055	LAF8837	VA-264	MA4045	VA-220	MA5403	VA-192	MO2222	VO-200
CAF1870P	VCA-1109	LAF8996	VA-380	MA4048	VA-245	MA5405	VA-155	MO2222	VO-201
CAF1872C	VCA-1078C	LFP5964	VO-161	MA4052	VA-383	MA5414	VA-164	MO2222	VO-88
CAF1872P	VCA-1078	LFP6007	VO-163	MA4054	VA-384	MA5418	VA-162	MO2222	VO-88
CAF1873P	VCA-1061	LFP6288	VO-170	MA4278	VA-86	MA5420	VA-166	MO2222	VO-88
CAF1874P	VCA-1116	LFP734	VO-162	MA4343	VA-205	MA5431	VA-176	MO241	VO-118
CAF1875P	VCA-1171	LFP784	VO-46	MA4372	VA-90	MA5432	VA-163	MO241	VO-118
CAF1876P	VCA-1115	LFP805	VO-136	MA4378	VA-70	MA5433	VA-161	MO241	VO-15
CAF1878P	VCA-1094	LP2017CAPT	VO-81CAP	MA4479	VA-78	MA5446	VA-167	MO241	VO-25
CAF1879P	VCA-1076	MA1890	VA-241	MA4633	VA-269	MA5455	VA-196	MO257	VO-156
CAF1880P	VCA-1072	MA2883	VA-223	MA4645	VA-96	MA5462	VA-160	MO2808	VO-106
CAF1882P	VCA-1147	MA2884	VA-224	MA4650	VA-101	MA5463	VA-171	MO289	VO-35
CAF1883P	VCA-1117	MA2886	VA-239	MA4688	VA-207	MA5499	VA-270	MO3040	VO-77
CAF1884P	VCA-1057	MA2893	VA-246	MA4690	VA-102	MA5503	VA-183	MO3969	VO-129
CAF1885P	VCA-1118	MA2947	VA-218	MA4712	VA-404	MA5507	VA-184	MO3986	VO-85
CAF1886P	VCA-1093	MA2959	VA-381	MA4712	VFAP-7854	MA5512	VA-177	MO4006	VO-108
CAF1887P	VCA-1071	MA3083	VA-225	MA4715	VA-99	MA5517	VA-247	MO4006	VO-58
CAF1890P	VCA-1073	MA3095	VA-219	MA4720	VA-104	MA5521	VA-189	MO4011	VO-55
CAF1891P	VCA-1098	MA3096	VA-263	MA4721	VFAP-7859	MA5528	VA-182	MO4457	VO-25
CAF1896P	VCA-1120	MA3138	VA-255	MA4722	VFAP-7892	MA5535	VA-174	MO4460	VO-106
CAF1897C	VCA-1080	MA3141	VA-295	MA4727	VA-105	MA5553	VA-179	MO4476	VO-40
CAF1898P	VCA-1077	MA3145	VA-285	MA4731	VA-108	MA5556	VA-181	MO4484	VO-60
CAF1899P	VCA-1177	MA3148	VA-327	MA4819	VA-107	MA5560	VA-180	MO4612	VO-106
CAF1900P	VCA-1081	MA3173	VA-280	MA4831	VFAP-7857	MA5566	VA-197	MO4612	VO-106
CAF1903P	VCA-1082	MA3195	VA-38	MA4832	VA-106	MA5568	VA-186	MO4651	VO-88
CAF1904C	VCA-1183	MA3217	VA-373	MA4852	VFAP-917	MA5578	VA-195	MO4670	VO-95
CAF1904P	VCA-1184	MA3380	VA-44	MA4873	VA-113	MA5582	VA-215	MO4670	VO-95
CAF1907P	VCA-1175	MA3465	VA-69	MA4877	VA-89	MA5583	VA-216	MO4670	VO-95
CAF1908P	VCA-1174	MA3590	VA-65	MA4878	VA-94	MA5584	VA-208	MO4872	VO-63
CAF1911P	VCA-1097	MA3592	VA-66	MA4880	VA-109	MA5588	VA-188	MO5274	VO-67
CAF1914P	VCA-1173	MA3601	VA-249	MA4881	VA-110	MA5595	VA-187	MO5309	VO-73
CAF1918P	VCA-1176	MA3895	VA-194	MA4886	VA-125	MA5602	VA-227	MO5313	VO-56
CAF1919C	VCA-1187	MA3896	VA-274	MA4904	VA-284	MA5603	VA-200	MO5313	VO-56
CAF1921P	VCA-1179	MA3899	VA-368	MA5028	VA-349	MA5604	VA-217	MO5313	VO-65
CAF1924P	VCA-1193	MA3908	VA-367	MA5048	VA-112	MA5634	VA-213	MO5313	VO-65
CAF1925P	VCA-1186	MA3910	VA-317	MA5049	VFAP-7893	MA5635	VA-229	MO5315	VO-66
CAF1941P	VCA-1178	MA3935	VA-323	MA5089	VA-129	MA5649	VA-214	MO5335	VO-64
CAF1944P	VCA-1181	MA3936	VA-365	MA5090	VA-92	MA5650	VA-209	MO5399	VO-75
CAF1945P	VCA-1189	MA3938	VA-309	MA5148	VFAP-7908	MA5651	VA-202	MO5436	VO-76
CAF1947P	VCA-1191	MA3940	VA-448	MA5150	VA-135	MA5653	VA-212	MO5505	VO-80
CAF1948P	VCA-1190	MA3958	VA-206	MA5155	VFAP-1643	MA5707	VA-203	MO5515	VO-81
CAF1949P	VCA-1188	MA3965	VA-337	MA5190	VA-273	MA6306	VA-237	MO5545	VO-150
CAF1950P	VCA-2035	MA3983	VA-251	MA5192	VA-260	MA67	VA-402	MO5608	VO-84
CAF1953P	VCA-1185	MA3984	VA-198	MA5192	VA-322	MA6900	VA-267	MO5610	VO-90
CAF1957C	VCA-1195	MA3998	VA-289	MA5219	VA-144	MA6902	VA-266	MO610	VO-101
CAF1961P	VCA-2043	MA3999	VA-226	MA5227	VA-91	MA7039	VA-157	MO8153	VO-69
CAF7702	VCA-1166	MA4	VA-321	MA5244	VA-153	MA7823	VA-261	MO8170	LC-8170
CAF7715	VCA-1150	MA4001	VA-228	MA5248	VA-117	MA7906	VA-132	MO842	VO-97
CAF7721	VCA-1162	MA4002	VA-210	MA5249	VA-118	MA7939	VA-315	MO85	VO-37
CAF7722	VCA-1127	MA4003	VA-201	MA5265	VA-116	MA7985	VA-333	MO907	VO-138
CAF7742	VCA-1165	MA4004	VA-353	MA5266	VA-147	MA91	VA-2	MO968	VO-87
CAF7749	VCA-1168	MA4010	VA-282	MA5267	VA-138	MA9546	VA-335	MO969	VO-91
CAF7757	VCA-1164	MA4014	VA-230	MA5290	VA-114	MCAF1706	VCA-1002	MO979	VO-96
CAF7759	VCA-1131	MA4015	VA-231	MA5301	VA-142	MCAF1707	VCA-1003	MO980	VO-102

CAUTION: For general references only. Check catalog for correct filter application. Any use of this interchange to determine filter application is done at the installers risk.

PRECAUCION: Solamente para referencias generales. Revise el catálogo para la correcta aplicación del filtro. Cualquier uso de la referencia cruzada para determinar la aplicación del filtro es riesgo del instalador. ATTENTION : Seulement pour les références d'ordre général. Contrôler l'application correcte du filtre avec le catalogue. Toute utilisation de moyens afin de déterminer l'application d'un filtre est faite aux risques de l'installateur.

Cross Reference

Table da equivalencias da fabricantes

Code de renvoi au fabricant

MFR'S NUMBER	REPLACEMENT NUMBER	MFR'S NUMBER	REPLACEMENT NUMBER	MFR'S NUMBER	REPLACEMENT NUMBER	MFR'S NUMBER	REPLACEMENT NUMBER	MFR'S NUMBER	REPLACEMENT NUMBER
MOBIL		M1C-251	VO-84	M1C-455A	VO-110	MO-416	VO-106	FA10	VA-321
MO981	VO-98	M1C-252	LC-8170	M1C-456A	VO-114	MO-452	VO-118	FA10R	VA-321
MO982	VO-99	M1C-253	VO-103	M1C-651A	VO-81	MO-744	VO-110	FA1031	VA-69
MO985	VO-103	M1C-253	VO-69	M1-101A	VO-16	MO-769	VO-88	FA1032	VA-205
MO990	VO-110	M1C-254	VO-67	M1-102A	VO-25	MO-899	VO-88	FA1042	VA-413
PH10066	VO-202	M1C-255	VO-99	M1-103A	VO-40	OFE00134	VO-65	FA1043	VA-66
PH2005	VO-25	M1C-256	VO-87	M1-104A	VO-106	OFE00146	VO-106	FA1046	VA-70
PH24	VO-108	M1C-451	VO-85	M1-107A	VO-108	OFE00148	VO-1	FA1057	VA-411
PH26	VO-88	M1C-453	VO-96	M1-107A	VO-58	OFE00163	VO-58	FA1059	VA-44
PH2817	VO-27	M1C-454	VO-90	M1-108A	VO-106	OFE00168	VO-58	FA1061	VA-88
PH2855	VO-135	M1C-455	VO-110	M1-108A	VO-106	OFE00190	VO-25	FA1072	VA-416
PH2873	VO-123	M1C-651	VO-81	M1-110A	VO-106	OFE00199	VO-16	FA1073	VFAP-7854
PH2878	VO-175	M1-101	VO-16	M1-111A	VO-65	OFE00213	VO-25	FA1085	VA-65
PH2892	VO-143	M1-102	VO-25	M1-111A	VO-65	OFE00215	VO-118	FA1087	VA-86
PH2903	VO-52	M1-103	VO-40	M1-113A	VO-152	OFE00229	VO-106	FA1088	VA-65
PH2905	VO-86	M1-104	VO-106	M1-113A	VO-160	OFE00233	VO-27	FA1092	VA-85
PH2992	VO-124	M1-107	VO-58	M1-113A	VO-200	OFE00265	VO-55	FA1097	VA-408
PH453	VO-93	M1-108	VO-106	M1-113A	VO-88	OFE00292	VO-118	FA1099	VA-90
PH477	VO-122	M1-108	VO-106	M1-201A	VO-55	OFE00301	VO-88	FA1101	VA-84
PH48R	VO-152	M1-110	VO-106	M1-204A	VO-93	OFE00308	VO-40	FA1107	VA-414
PH488	VO-160	M1-111	VO-65	M1-204A	VO-95	OFE00310	VO-106	FA1109	VA-269
P1014	VO-142	M1-111	VO-65	M1-204A	VO-95	OFE00336	VO-88	FA1112	VA-96
P1015	VO-153	M1-113	VO-152	M1-204A	VO-95	OFE00344	VO-56	FA1115	VA-101
P1016	VO-164	M1-113	VO-160	M1-205A	VO-15	OFE00368	VO-118	FA1117	VFAP-7854
P1017	VO-117	M1-113	VO-200	M1-206A	VO-108	OFE00370	VO-106	FA1121	VFAP-7857
P1023	VO-174	M1-113	VO-88	M1-206A	VO-108	OFE00371	VO-108	FA1122	VA-106
P1026	VO-167	M1-201	VO-55	M1-208A	VO-25	OFE00372	VO-63	FA1127	VA-78
P1028	VO-165	M1-204	VO-93	M1-209A	VO-118	OFE00373	VO-75	FA1206	VA-38
P1035	VO-166	M1-204	VO-95	M1-209A	VO-118	MOTOMASTER		FA1331	VA-408
P1037	VO-168	M1-204	VO-95	M1-210A	VO-88	MCA160	VA-321	FA1338	VA-158
P1051	VO-173	M1-204	VO-95	M1-210A	VO-88	MCA326	VA-2	FA1611	VA-89
P1069	VO-172	M1-205	VO-15	M1-212A	VO-201	MCA3660	VA-69	FA1612	VFAP-1612
P1070	VO-169	M1-206	VO-108	M1-212A	VO-88	MCA3901	VA-90	FA1613	VFAP-1613
P141	VO-134	M1-207	VO-35	M1-212A	VO-88	MCA4309	VA-86	FA1614	VA-105
P2062	VO-115	M1-208	VO-25	M1-301A	VO-1	MCA5058	VA-66	FA1615	VA-94
P2902	VO-144	M1-209	VO-118	M1-301A	VO-15	MCA6366	VA-70	FA1616	VA-114
P2923	VO-119	M1-210	VO-88	M1-302A	VO-56	MCA7421	VA-108	FA1617	VA-93
P3968	VO-137	M1-210	VO-88	M1-302A	VO-56	MCA7597	VA-109	FA1618	VA-120
P3972	VO-130	M1-211	VO-118	M1-303A	VO-75	MCA7774	VA-114	FA1626	VCA-1157
P3987	VO-139	M1-212	VO-201	M1-403A	VO-64	MCA8039	VA-94	FA1628	VCA-1001
P4456	VO-78	M1-212	VO-88	M1-404A	VO-81	MCA8221	VA-91	FA1630	VA-404
P8198	VO-74	M1-213	VO-86	M1-405A	VO-104	MCA8754	VA-78	FA1632	VA-94
P833	LC-833	M1-213	VO-86	M1-601A	VO-63	MCA8755A	VA-324	FA1633	VA-94
P834	LC-834	M1-301	VO-1	MOPAR (ALSO SEE CHRYSLER)		MCA8911	VA-165	FA1634	VA-94
P838	VO-127	M1-301	VO-15	J8133965	VO-58	MCH10246	VO-98	FA1641	VFA-1641
P843	VO-62	M1-302	VO-56	J8991072	VO-108	MCH10358	VO-102	FA1643	VFAP-1643
P8445	LC-8445	M1-302	VO-56	MA-051	VA-264	MCH10955	VO-110	FA1658	VA-260
P845	VO-70	M1-303	VO-75	MA-249	VA-287	MPH10060	VO-200	FA1665	VA-260
P856	VO-71	M1-402	VO-46	MA-404	VA-160	MPH10060	VO-88	FA1668	VA-205
P929	VO-128	M1-403	VO-64	MA-713	VA-154	MPH16	VO-95	FA1669	VA-410
P961	VO-94	M1-404	VO-101	MA-737	VA-286	MPH2	VO-88	FA1673	VA-114
P962	VO-112	M1-405	VO-104	MA-746	VA-293	MPH3506	VO-58	FA1675	VA-410
P964	VO-82	M1-601	VO-63	MA-756	VA-273	MPH3600	VO-118	FA1679	VA-142
P966	VO-92	MOBIL 1 NEW		MA-777	VA-164	MPH3614	VO-25	FA1680	VA-122
P975	VO-120	M1C-151A	VO-76	MA-914	VA-290	MPH3675	VO-108	FA1683	VA-149
P978	VO-111	M1C-152A	VO-66	MA-926	VA-154	MPH3682	VO-25	FA1688	VA-140
P983	VO-140	M1C-153A	VO-80	MC-044	VCA-1176	MPH3980	VO-55	FA1695	VA-162
P986	VO-141	M1C-154A	VO-102	MC-193	VCA-1093	MPH4967	VO-40	FA1696	VA-149
P987	VO-131	M1C-155A	VO-91	MC-487	VCA-1073	MPH5	VO-56	FA1697	VA-94
P989	VO-109	M1C-251A	VO-84	MC-501	VCA-2033	MPH6607	VO-106	FA1710	VA-167
P992	VO-149	M1C-252A	LC-8170	MC-668	VCA-1077	MPH7317	VO-106	FA1711	VA-142
P993	VO-116	M1C-253A	VO-103	MC-693	VCA-1069	MPH8A	VO-1	FA1744	VA-322
P995	VO-132	M1C-253A	VO-69	MC-809	VCA-1044	MPH9688	VO-106	FA1745	VA-205
P996	VO-121	M1C-254A	VO-67	MC-981	VCA-1037	MPH9837	VO-108	FA1746	VA-174
P997	VO-151	M1C-255A	VO-99	MO-090	VO-95	MOTORCRAFT		FA1750	VA-167
P998	VO-133	M1C-256A	VO-87	MO-231	VO-88	CFA1059	VA-44	FA1754	VA-182
MOBIL 1		M1C-257A	VO-98	MO-285	VO-64	CFA2002	VA-85	FA1771	VA-197
M1C-151	VO-76	M1C-351A	VO-115	MO-301	VO-69	CFL1	VO-1	FA1772	VA-249
M1C-152	VO-66	M1C-451A	VO-85	MO-339	VO-88	CFL1003	VO-55	FA1773	VA-186
M1C-153	VO-80	M1C-453A	VO-96	MO-349	VO-114	CFL815	VO-162	FA1778	VA-174
M1C-154	VO-102	M1C-454A	VO-90	MO-409	VO-25	EFL404	VO-80	FA1780	VA-222

CAUTION: For general references only. Check catalog for correct filter application. Any use of this interchange to determine filter application is done at the installers risk.
 PRECAUCION: Solamente para referencias generales. Revise el catálogo para la correcta aplicación del filtro. Cualquier uso de la referencia cruzada para determinar la aplicación del filtro es riesgo del instalador. ATTENTION : Seulement pour les références d'ordre général. Contrôler l'application correcte du filtre avec le catalogue. Toute utilisation de moyens afin de déterminer l'application d'un filtre est faite aux risques de l'installateur.

Cross Reference

Table da equivalencias da fabricantes

Code de renvoi au fabricant

MFR'S NUMBER	REPLACEMENT NUMBER	MFR'S NUMBER	REPLACEMENT NUMBER	MFR'S NUMBER	REPLACEMENT NUMBER	MFR'S NUMBER	REPLACEMENT NUMBER	MFR'S NUMBER	REPLACEMENT NUMBER
MOTORCRAFT		FG872	VG-32	FL816	VO-106	1034	VO-15	1365	VO-106
FA1782	VA-382	FG873	VG-16	FL820	VO-88	1036	VO-55	1366	VO-40
FA1783	VA-205	FL1	VO-1	FL820S	VO-88	1036MP	VO-55	1367	VO-25
FA1785	VA-215	FL1A	VO-1	FL821	VO-106	1040	VO-16	1369	VO-145
FA1786	VA-216	FL10	VO-65	FL822	VO-106	1040MP	VO-16	1372	VO-88
FA1787	VA-90	FL12A	VO-56	FL836	VO-40	1042	VO-58	1372MP	VO-88
FA1788	VA-269	FL13A	VO-25	FL838	VO-37	1042MP	VO-58	1376	VO-163
FA1789	VA-102	FL181	VO-1	FL839	VO-25	1045	VO-108	1378	VO-60
FA1790	VFAP-7892	FL181	VO-15	FL842	VO-95	1046	VO-65	1381	VO-19
FA1791	VA-108	FL1995	VO-63	FL896	VO-64	1049	VO-108	1389	VO-106
FA1792	VA-109	FL1997	VO-86	FL896A	VO-64	1060	VO-56	1389	VO-25
FA1793	VA-110	FL1998	VO-106	FL9	VO-108	1060MP	VO-56	1391	VO-25
FA1794	VA-65	FL200	VO-95	FL910	VO-25	1061	VO-56	1392	VO-27
FA1796	VA-91	FL2005	VO-118	FL910S	VO-25	1061MP	VO-56	1393	VO-15
FA1797	VA-116	FL2007	VO-106	FP14	VCA-1001	1064	VO-106	1394	VO-40
FA1798	VA-105	FL2008	VO-86	FP22A	VCA-1008	1064MP	VO-106	1395	VO-40
FA1799	VA-92	FL2016	VO-81	FP25	VCA-1125	1067	VO-136	1396	VO-40
FA1800	VA-259	FL2017A	VO-80	FP38	VCA-1163	1068	VO-95	1452	VO-15
FA1805	VA-205	FL2017B	VO-80	FP39	VCA-1157	1068MP	VO-95	1452MP	VO-15
FA1883	VA-223	FL2021	VO-86	FP4	VCA-1157	1069	VO-65	1452MP	VO-95
FA1884	VA-224	FL2030	VO-58	FP46	VCA-1200	1069MP	VO-65	1512	VO-15
FA1886	VA-239	FL2051	VO-104	FP49	VCA-1020	107503	VO-25	1515	VO-1
FA1890	VA-241	FL2051S	VO-104	FP50	VCA-1001	107509	VO-91	1515MP	VO-1
FA1893	VA-246	FL2055	VO-88	FP51	VCA-1101	1083	VO-52	1516	VO-118
FA1897	VA-253	FL2056	VO-88	FP53	VCA-1102	1084	VO-95	1516MP	VO-118
FA1900	VA-267	FL2058	VO-76	FP54	VCA-1001	1085	VO-95	1521	VO-95
FA1902	VA-266	FL2060	VO-84	FP56	VCA-1003	1085MP	VO-95	1522	VO-108
FA1904	VA-284	FL2062	VO-115	FP57	VCA-1002	1088	VO-15	1522MP	VO-108
FA1906	VA-223	FL2063	VO-102	FP58	VCA-1014	1143	VO-134	1525	VO-1
FA1908	VA-288	FL2064	VO-67	FP6	VCA-1001	1145	VO-62	1568	VO-106
FA1910	VA-298	FL2065	VO-110	FP65	VCA-1049	1160	LC-834	1607	VO-64
FA1911	VA-429	FL2066	VO-114	FP66	VCA-1104	1170	VO-144	1607MP	VO-64
FA1912	VA-306	FL218	VO-86	FP67	VCA-1059	1185	LC-833	1626	VO-35
FA1912A	VA-306	FL22	VO-134	FP68	VCA-1118	1186	VO-74	1627	VO-156
FA1914	VA-284	FL267	VO-25	FP69	VCA-1177	1189	VO-95	1630	VO-37
FA1916	VA-451	FL271	VO-40	FP7A	VCA-1017	1190	VO-55	1649	VO-162
FA1918	VA-430	FL276	VO-118	FP70	VCA-1081	1191	VO-15	1673	VO-162
FA1923	VA-266	FL295	VO-52	FP71	VCA-1174	1191	Exc. Audi/VW	VO-159	1675
FA1927	VA-462	FL300	VO-95	FP72	VCA-1102	1212	VO-150	1734	VO-63
FA1928	VA-463	FL306	VO-35	FP78	VCA-1186	1213	LC-8445	1734MP	VO-63
FA1935	VA-501	FL321	VO-16	FP79	VCA-1185	1215	VO-25	1742	VO-46
FA31	VA-402	FL330	VO-58	SFL100	VO-25	1223	LC-8170	1742MP	VO-46
FA31R	VA-402	FL331	VO-108	SFL200	VO-1	1224	VO-143	1762	VO-118
FA618	VA-321	FL332	VO-95	SFL203	VO-56	1226	VO-69	1764	VO-118
FA637	VA-411	FL400	VO-118	SFL204	VO-25	1227	VO-119	1775	VO-1
FA675	VA-34	FL400A	VO-118	SFL205	VO-108	1228	VO-86	1785	VO-25
FA697	VA-45	FL400S	VO-118	SFL206	VO-65	1231	VO-86	1798	VO-163
FA705	VA-45	FL401	VO-15	SFL214	VO-1	1246	VO-70	1833	VO-162
FA71	VA-2	FL402	VO-55	SFL237	VO-25	1258	VO-108	200000	VA-344
FA71R	VA-2	FL403	VO-19	SFL253	VO-1	1287	VO-135	200005	VA-450
FA725	VA-48	FL408	VO-19	SFL262	VO-52	1307	VO-95	200006	VA-473
FA746	VA-411	FL5	VO-95	NAPA GOLD		1311	VO-95	200008	VA-303
FA75	VA-403	FL500	VO-88	100001	VO-123	1312	VO-95	200022	VA-392
FA75R	VA-403	FL500S	VO-88	100010	VO-114	1315	VO-118	200036	VA-429
FA752	VA-69	FL752	VO-52	100021	VO-153	1324	VO-19	200048	VA-306
FA768	VA-38	FL755	VO-65	100024	VO-117	1333	VO-15	200050	VA-419
FA949	VA-40	FL757	VO-27	100032	VO-109	1334	VO-106	200058	VA-437
FA992	VA-44	FL776	VO-25	100033	VO-167	1334	VO-106	200085	VA-440
FA999	VA-69	FL782	VO-40	100050	VO-115	1334	VO-52	200095	VA-298
FD259	VO-95	FL784	VO-46	100056	VO-165	1334MP	VO-106	200096	VA-434
FG1006	VG-16	FL786	VO-35	100058	VO-170	1342	VO-15	200127	VA-417
FG1009	VG-16	FL787	VO-95	100059	VO-151	1344	VO-106	200164	VA-331
FG1106	VG-33	FL791	VO-118	100060	VO-142	1347	VO-52	200196	VA-434
FG1110	VG-30	FL793	VO-25	100078	VO-106	1348	VO-25	200212	VA-432
FG14	VG-2	FL799	VO-106	100164	VO-109	1348MP	VO-25	200215	VA-438
FG14A	VG-2	FL803	VO-106	100186	VO-172	1355	VO-93	200253	VA-308
FG14B	VG-2	FL805	VO-136	100223	VO-168	1356	VO-106	200254	VA-308
FG14C	VG-2	FL807	VO-163	100255	VO-88	1357	VO-106	200255	VA-424
FG800	VG-16	FL810	VO-106	100290	VO-200	1361	VO-15	200256	VA-425
FG800A	VG-16	FL810A	VO-106	100331	VO-98	1362	VO-95	200257	VA-490
FG851	VG-14	FL813	VO-35	100332	VO-175	1364	VO-15	200261	VA-284

CAUTION: For general references only. Check catalog for correct filter application. Any use of this interchange to determine filter application is done at the installers risk.

PRECAUCION: Solamente para referencias generales. Revise el catálogo para la correcta aplicación del filtro. Cualquier uso de la referencia cruzada para determinar la aplicación del filtro es riesgo del instalador. ATTENTION : Seulement pour les références d'ordre général. Contrôler l'application correcte du filtre avec le catalogue. Toute utilisation de moyens afin de déterminer l'application d'un filtre est faite aux risques de l'installateur.

Cross Reference

Table da equivalencias da fabricantes

Code de renvoi au fabricant

MFR'S NUMBER	REPLACEMENT NUMBER	MFR'S NUMBER	REPLACEMENT NUMBER	MFR'S NUMBER	REPLACEMENT NUMBER	MFR'S NUMBER	REPLACEMENT NUMBER	MFR'S NUMBER	REPLACEMENT NUMBER
NAPA GOLD		2306	VA-399	400116	VO-106	4782	VCA-1167	6081	VA-129
200263	VCA-1193	2324	VA-321	4012	VCA-1171	4794	VCA-1053	6083	VA-98
200268	VA-453	2329	VA-164	4013	VCA-1075	4805	VCA-1003	6086	VA-321
200269	VA-431	2333	VA-408	4014	VCA-1076	4807	VCA-1008	6088	VA-269
200271	VA-418	2341	VA-142	4015	VCA-1072	4808	VCA-1163	6093	VA-88
200296	VA-428	2351	VA-380	4017	VCA-1073	4811	VCA-1021	6095	VFAP-7857
200312	VA-449	2384	VA-137	4020	VCA-1038	4812	VA-1161	6097	VA-416
200315	VA-430	2385	VA-149	4030	VCA-1055	4813	VCA-1165	6098	VA-106
200316	VA-451	2389	VA-154	4036	VCA-1098	4814	VCA-1169	6105	VFAP-7893
200317	VA-453	239309	VCA-1108	4046	VCA-1094	4815	VCA-1063	6108	VA-101
200335	VA-458	2412	VA-333	4048	VCA-1077	4816	VCA-1020	6109	VA-125
200337	VA-455	2461	VA-394	4053	VCA-1120	4817	VCA-1012	6116	VA-86
200339	VA-456	2468	VA-371	4065	VCA-1049	4818	VCA-1040	6117	VA-108
200394	VA-466	2472	VA-138	4068	VCA-1118	4819	VCA-1161	6120	VA-40
200403	VA-490	2476	VA-146	4080	VCA-1071	4821	VCA-1161	6126	VA-66
200414	VA-459	2479	VA-146	4094	VA-111	4822	VCA-1026	6128	VA-413
200416	VA-454	2484	VA-162	4103	VCA-1175	4823	VCA-1096	6133	VA-69
200417	VA-464	2486	VA-397	4118	VCA-1106	4826	VCA-1089	6134	VA-205
200418	VA-453	2487	VA-259	4148	VCA-1116	4829	VCA-1052	6139	VA-65
200420	VA-465	2488	VA-271	4191	VCA-1078C	4853	VCA-1139	6144	VFAP-917
200422	VA-488	2524	VA-140	4200	VCA-1109	4854	VCA-1048	6153	VA-78
200427	VA-451	2551	VA-193	4201	VCA-1061	4855	VCA-1159	6162	VA-96
200646	VA-471	2564	VA-165	4211	VCA-1183	4857	VCA-1068	6174	VA-70
200649	VA-461	2612	VA-207	4212	VCA-1110	4863	VCA-1039	6180	VA-85
200679	VA-462	2625	VA-363	4300	VCA-1062	4864	VCA-1168	6195	VA-144
200695	VA-469	2697	VA-411	4302	VCA-1097	4865	VCA-1029	6213	VA-105
200697	VA-463	2725	VA-160	4313	VCA-1069	4868	VCA-1164	6215	VA-153
200713	VA-498	2727	VA-345	4322	VCA-1166	4869	VCA-1043	6221	VA-389
200718	VA-467	2728	VA-150	4367	VCA-1059	4871	VCA-1037	6242	VA-414
200813	VA-497	2729	VA-161	4400	VCA-1038	4872	VCA-1030	6244	VA-84
200831	VA-501	2731	VA-174	4419	VCA-1081	4873	VCA-1028	6245	VA-148
200841	VA-499	2737	VA-379	4473	VCA-1162	4875	VCA-1014	6253	VA-260
2013	VA-181	2740	VA-172	4474	VCA-1022K	4876	VCA-1017	6253	VA-322
2015	VA-147	2749	VA-350	4475	VCA-1134	4877	VCA-1122	6255	VA-411
2020	VA-321	2750	VA-179	4477	VCA-1101	4878	VCA-1060	6271	VA-387
2023	VA-361	2752	VA-377	4478	VCA-1056	4879	VCA-1054	6272	VA-111
2086	VA-185	2793	VA-149	4479	VCA-1044	4881	VCA-1139	6273	VFAP-7892
2088	VA-402	2797	VA-152	4482	VCA-1046	4882	VCA-1065	6288	VFAP-7859
2096	VA-45	2799	VA-199	4483	VCA-1031	4883	VCA-1014	6289	VA-89
2098	VA-2	2800	VA-355	4484	VCA-1138	4884	VCA-1125	6293	VA-111
2101	VA-403	2822	VA-400	4488	VCA-1031	4893	VCA-1129	6298	VA-132
2133	VA-69	2823	VA-352	4489	VCA-1135	4894	VCA-1024	6301	VA-110
2164	VA-247	2825	VA-190	4517	VCA-1035	4897	VCA-1013	6302	VA-109
2177	VFAP-7912	2826	VA-340	4524	VCA-1110	4899	VCA-1160	6303	VA-113
2181	VA-270	2831	VA-188	4526	VCA-1144	4900	VCA-1042	6308	VA-128
2188	VA-196	2834	VA-208	4569	VCA-1014	4901	VCA-1067	6316	VA-412
2190	VA-342	2838	VA-386	4577	VCA-1031	4902	VCA-1155	6318	VA-131
2214	VA-395	2839	VA-337	4579	VCA-1064	4903	VCA-1170	6320	VFAP-7865
2295	VA-157	2843	VA-180	4579	VCA-1070	4905	VCA-1133	6322	VA-170
230013	VCA-1082	2844	VA-202	4590	VCA-1078	4907	VCA-1070	6327	VA-124
230074	VCA-1080	2846	VA-177	4600	VCA-1115	4909	VCA-2033	6339	VFAP-1613
230083	VCA-1051	2859	VA-204	4619	VCA-1177	500165	VA-485	6340	VA-346
230084	VCA-1174	2863	VA-362	4673	VCA-1162	6006	VFAP-7859	6349	VFAP-1612
230105	VCA-1102	2864	VA-336	4682	VCA-1113	6017	VA-102	6358	VFAP-7908
230129	VCA-1173	2879	VA-359	4683	VCA-1041	6018	VA-321	6388	VA-135
230142	VCA-1176	2885	VA-194	4684	VCA-1047	6026	VA-103	6390	VA-120
230155	VCA-1181	2891	VA-151	4685	VCA-1146	6027	VA-97	6398	VA-338
230178	VCA-1179	2897	VA-90	4686	VCA-1126	6028	VA-104	6406	VFAP-1643
230179	VCA-1178	2972	VA-325	4687	VCA-1102	6030	VA-401	6416	VA-114
230192	VCA-1184	2993	VA-48	4688	VCA-1172	6035	VA-91	6417	VA-93
230195	VCA-1186	3046	VG-2	4689	VCA-1066	6036	VA-44	6418	VA-94
230207	VCA-1188	3097	VG-16	4725	VCA-1036	6040	VA-38	6419	VFA-1641
230234	VCA-1075	3097MP	VG-16	4752	VCA-1167	6043	VA-408	6425	VA-112
230265	VCA-1190	3296	VG-32	4753	VCA-1144	6044	VA-261	6428	VA-404
230277	VCA-2043	3296MP	VG-32	4756	VCA-1147	6051	VFAP-7854	6440	VA-92
230316	VCA-1195	3311	VG-33	4757	VCA-1131	6053	VA-370	6441	VA-320
230319	VCA-1191	3311MP	VG-33	4761	VCA-1057	6057	VA-99	6443	VA-117
230320	VCA-2035	3481	VG-14	4765	VCA-1124	6058	VA-158	6444	VA-118
230320	VCA-2051	3481MP	VG-14	4771	VCA-1157	6064	VA-83	6462	VA-178
230367	VCA-1062	3484	VG-30	4773	VCA-1001	6077	VA-90	6463	VA-136
230369	VCA-2055	400068	VO-25	4780	VCA-1002	6080	VA-107	6464	VA-339

CAUTION: For general references only. Check catalog for correct filter application. Any use of this interchange to determine filter application is done at the installers risk.
 PRECAUCION: Solamente para referencias generales. Revise el catálogo para la correcta aplicación del filtro. Cualquier uso de la referencia cruzada para determinar la aplicación del filtro es riesgo del instalador. ATTENTION : Seulement pour les références d'ordre général. Contrôler l'application correcte du filtre avec le catalogue. Toute utilisation de moyens afin de déterminer l'application d'un filtre est faite aux risques de l'installateur.

Cross Reference

Table da equivalencias da fabricantes

Code de renvoi au fabricant

MFR'S NUMBER	REPLACEMENT NUMBER	MFR'S NUMBER	REPLACEMENT NUMBER	MFR'S NUMBER	REPLACEMENT NUMBER	MFR'S NUMBER	REPLACEMENT NUMBER	MFR'S NUMBER	REPLACEMENT NUMBER
NAPA GOLD									
		7099	VO-65	9016	VA-245	9200	VA-294	9750	VA-304
6465	VA-159	7141	VO-106	9017	VA-288	9201	VA-253	9756	VA-273
6472	VA-116	7143	VO-122	9018	VA-258	9208	VA-443	9760	VA-305
6484	VA-410	7144	VO-110	9020	VA-274	9210	VA-283	9800	VA-385
6493	VA-279	7145	VO-40	9022	VA-300	9211	VA-393	9825	VA-326
6503	VA-65	7148	VO-25	9023	VA-278	9220	VA-184	9830	VA-457
6573	VA-169	7151	VO-104	9030	VA-234	9223	VA-214	9843	VA-318
6646	VA-191	7162	VO-139	9031	VA-292	9224	VA-351	9846	VA-329
6648	VA-122	7170	VO-144	9034	VA-442	9225	VA-244	9873	VA-375
6653	VA-335	7171	VO-128	9038	VA-301	9229	VA-364	9876	VA-349
6659	VA-114	7172	VO-143	9040	VA-221	9230	VA-275	9883	VA-223
6673	VA-163	7173	VO-87	9041	VA-220	9235	VA-316	9886	VA-239
6674	VA-166	7175	VO-112	9042	VA-202	9240	VA-445	9888	VA-373
6677	VA-155	7181	VO-25	9043	VA-313	9244	VA-327	9890	VA-241
6678	VA-324	7186	VO-85	9048	VA-310	9247	VA-302	9893	VA-246
6699	VA-156	7187	VO-85	9049	VA-287	9250	VA-265	9894	VA-254
6728	VA-167	7189	VO-131	9051	VA-328	9264	VA-427	9901	VA-267
6798	VA-347	7202	VO-75	9052	VA-227	9270	VA-366	9902	VA-266
6799	VA-132	7203	VO-80	9053	VA-216	9285	VA-396	9907	VA-341
6802	VA-192	7204	VO-92	9054	VA-211	9288	VA-299	9926	VA-154
6803	VA-270	7210	VO-71	9056	VA-323	9293	VA-354	9933	VA-232
6804	VA-182	7211	VO-127	9057	VA-233	9310	VA-309	9946	VA-272
6814	VA-205	7241	VO-124	9058	VA-252	9314	VA-295	NAPA PLATINUM	
6831	VA-183	7250	VO-99	9059	VA-372	9320	VA-257	37045	VO-88
6832	VA-184	7254	VO-145	9063	VA-184	9344	VA-315	4100010	VO-114
6834	VA-171	7260	VO-121	9064	VA-217	9352	VCA-1034	41036	VO-55
6835	VA-330	7262	VO-132	9065	VA-212	9353	VCA-1050	41040	VO-16
6873	VA-206	7279	VO-141	9066	VA-360	9355	VCA-1158	41042	VO-58
6879	VA-189	7301	VO-118	9067	VA-213	9357	VCA-1153	41060	VO-56
6887	VA-175	7302	VO-86	9069	VA-201	9358	VCA-1037	41085	VO-95
6888	VA-195	7303	VO-82	9070	VA-235	9359	VCA-1114	41223	LC-8170
6889	VA-187	7310	VO-96	9071	VA-360	9362	VA-332	41226	VO-103
6902	VA-176	7311	VO-81	9073	VA-312	9363	VCA-1068	41315	VO-118
6914	VA-198	7314	VO-81	9085	VA-374	9368	VCA-1075	41334	VO-106
6916	VA-356	7323	No attached Cap	VO-81	VA-242	9371	VCA-1103	41334	VO-106
6917	VA-269	7327		VO-91	VCA-1093	9372	VCA-1127	41334	VO-52
6924	VA-197	7328		VO-137	VA-435	9377	VCA-1051	41348	VO-25
6930	VA-264	7329		VO-94	VA-383	9400	VA-268	41356	VO-106
6935	VA-224	7330		VO-138	VCA-1061	9429	VA-219	41365	VO-106
6938	VA-314	7334		VO-106	VA-236	9430	VA-273	41372	VO-88
6975	VA-186	7341		VO-116	VA-231	9450	VA-265	41394	VO-40
7000	VO-25	7356		VO-106	VA-378	9459	VA-388	41515	VO-1
7002	VO-106	7371		VO-25	VA-230	9460	VA-250	41516	VO-118
7021	VO-66	7430		VO-95	VA-215	9461	VA-317	41522	VO-108
7023	VO-25	7462		VO-133	VA-200	9466	VCA-1104	41734	VO-63
7029	VO-99	7502		VO-88	VA-251	9468	VA-423	47021	VO-66
7033	VO-73	7503		VO-25	VA-203	9475	VA-280	47041	VO-96
7038	VO-69	7510		VO-106	VA-210	9480	VA-334	47045	VO-88
7040	VO-106	7512		VO-111	VA-237	9498	VA-263	47047	VO-84
7040	VO-106	7521		VO-161	VA-202	9530	VA-297	47060	VO-88
7041	VO-96	7526		VO-110	VA-365	9545	VA-367	47064	VO-102
7042	VO-99	7530		VO-40	VA-357	9555	VA-444	47082	VO-76
7045	VO-88	7560		VO-140	VA-382	9570	VA-391	47099	VO-65
7046	VO-52	7561		VO-101	VA-448	9590	VA-426	47145	VO-40
7047	VO-84	7563		VO-150	VA-222	9593	VA-446	47151	VO-104
7055	VO-106	7620		VO-64	VA-289	9600	VA-384	47186	VO-85
7059	VO-149	7620MP		VO-64	VA-381	9604	VA-284	47202	VO-75
7060	VO-88	7674		VO-98	VA-248	9610	VA-390	47203	VO-80
7060MP	VO-88	7712		VO-106	VA-228	9630	VA-307	47312	VO-81
7061	VO-90	7806		VO-97	VA-343	9634	VA-225	47356	VO-106
7062	VO-129	7830		VO-106	VA-296	9640	VA-319	47502	VO-88
7063	VO-88	7899		VO-88	VA-202	9651	VA-280	47526	VO-110
7064	VO-102	9000		VA-238	VA-209	9670	VA-311	47620	VO-64
7073	VO-88	9001		VA-282	VA-243	9700	VCA-1117	NAPA POWER SPORT	
7077	VO-120	9004		VA-358	VA-247	9704	VA-452	PS1215	VO-25
7078	VO-103	9005		VA-368	VA-218	9727	VA-255	PS1334	VO-106
7079	VO-78	9006		VA-378	VA-353	9728	VA-447	PS1348	VO-25
7082	VO-76	9009		VA-291	VA-226	9730	VA-285	PS1356	VO-106
7083	VO-77	9010		VA-234	VA-249	9737	VA-286	PS1357	VO-106
7090	VO-67	9012		VA-198	VA-240	9739	VA-296	PS1365	VO-106
7092	VO-106	9014		VA-290	VA-229	9746	VA-293	PS1394	VO-40

CAUTION: For general references only. Check catalog for correct filter application. Any use of this interchange to determine filter application is done at the installers risk.

PRECAUCION: Solamente para referencias generales. Revise el catálogo para la correcta aplicación del filtro. Cualquier uso de la referencia cruzada para determinar la aplicación del filtro es riesgo del instalador. ATTENTION : Seulement pour les références d'ordre général. Contrôler l'application correcte du filtre avec le catalogue. Toute utilisation de moyens afin de déterminer l'application d'un filtre est faite aux risques de l'installateur.

Cross Reference

Table da equivalencias da fabricantes

Code de renvoi au fabricant

MFR'S NUMBER	REPLACEMENT NUMBER	MFR'S NUMBER	REPLACEMENT NUMBER	MFR'S NUMBER	REPLACEMENT NUMBER	MFR'S NUMBER	REPLACEMENT NUMBER	MFR'S NUMBER	REPLACEMENT NUMBER
NAPA POWER SPORT		21393	VO-15	224300	VCA-1062	22551	VA-193	26134	VA-205
PS7148	VO-25	21393MP	VO-15	224302	VCA-1097	22564	VA-165	26139	VA-65
NAPA PROSELECT		21394	VO-40	224313	VCA-1069	22612	VA-207	26144	VFAP-917
A9739	VA-296	21396	VO-40	224322	VCA-1166	22725	VA-160	26153	VA-78
009368	VCA-1075	21452	VO-15	224367	VCA-1059	22728	VA-150	26162	VA-96
2100001	VO-123	21515	VO-1	224400	VCA-1038	22729	VA-161	26174	VA-70
2100010	VO-114	21515MP	VO-1	224419	VCA-1081	22740	VA-172	26180	VA-85
2100024	VO-117	21516	VO-118	224479	VCA-1044	22750	VA-179	26195	VA-144
2100050	VO-115	21516MP	VO-118	224483	VCA-1031	22793	VA-149	26213	VA-105
2100056	VO-165	21521	VO-95	224484	VCA-1031	22797	VA-152	26215	VA-153
2100082	VO-109	21522	VO-108	224489	VCA-1135	22825	VA-190	26242	VA-414
2100164	VO-109	21522MP	VO-108	224517	VCA-1035	22831	VA-188	26244	VA-84
2100255	VO-88	21626	VO-35	224579	VCA-1064	22834	VA-208	26253	VA-260
2100290	VO-200	21630	VO-37	224619	VCA-1177	22839	VA-337	26253	VA-322
21034	VO-15	21734	VO-63	224673	VCA-1162	22843	VA-180	26255	VA-411
21036	VO-55	21734MP	VO-63	224683	VCA-1041	22844	VA-202	26272	VA-111
21036MP	VO-55	21742	VO-46	224684	VCA-1047	22846	VA-177	26273	VFAP-7892
21040	VO-16	2200008	VA-303	224685	VCA-1146	22859	VA-204	26288	VFAP-7859
21040MP	VO-16	2200036	VA-429	224687	VCA-1102	22864	VA-336	26289	VA-89
21042	VO-58	2200048	VA-306	224689	VCA-1066	22885	VA-194	26293	VA-111
21042MP	VO-58	2200058	VA-437	22472	VA-138	22891	VA-151	26301	VA-110
21045	VO-108	2200095	VA-298	224725	VCA-1036	229093	VCA-1093	26302	VA-109
21060	VO-56	2200096	VA-434	224752	VCA-1167	229101	VCA-1061	26303	VA-113
21060MP	VO-56	2200255	VA-424	224756	VCA-1147	229352	VCA-1034	26316	VA-412
21061	VO-56	2200256	VA-425	22476	VA-146	229353	VCA-1050	26318	VA-131
21068	VO-95	2200268	VA-453	224765	VCA-1124	229355	VCA-1158	26320	VFAP-7865
21068MP	VO-95	2200269	VA-431	224773	VCA-1001	229357	VCA-1153	26322	VA-170
21069	VO-65	2200271	VA-418	224780	VCA-1002	229358	VCA-1037	26327	VA-124
21069MP	VO-65	2200296	VA-428	22479	VA-146	229363	VCA-1068	26339	VFAP-1613
21085	VO-95	2200315	VA-430	224794	VCA-1053	229368	VCA-1075	26340	VA-346
21085MP	VO-95	2200339	VA-456	224805	VCA-1003	229371	VCA-1103	26349	VFAP-1612
21088	VO-15	22013	VA-181	224807	VCA-1008	229377	VCA-1051	26358	VFAP-7908
21145	VO-62	22015	VA-147	224808	VCA-1163	229466	VCA-1104	26388	VA-135
21160	LC-834	22020	VA-321	224812	VCA-1022	22972	VA-325	26390	VA-120
21186	VO-74	22086	VA-185	224813	VCA-1165	23046	VG-2	26398	VA-338
21191	VO-15	22088	VA-402	224814	VCA-1169	23097	VG-16	26406	VFAP-1643
21191	VO-159	22096	VA-45	224815	VCA-1063	23296	VG-32	26416	VA-114
21212	VO-150	22098	VA-2	224816	VCA-1020	23311	VG-33	26417	VA-93
21215	VO-25	22101	VA-403	224817	VCA-1012	23481	VG-14	26418	VA-94
21223	LC-8170	22133	VA-69	224818	VCA-1040	23484	VG-30	26419	VFA-1641
21223MP	LC-8170	22164	VA-247	224821	VCA-1161	26006	VFAP-7859	26425	VA-112
21226	VO-69	22177	VFAP-7912	224823	VCA-1096	26017	VA-102	26428	VA-404
21226MP	VO-69	22181	VA-270	224829	VCA-1052	26026	VA-103	26440	VA-92
21228	VO-86	22188	VA-196	22484	VA-162	26027	VA-97	26443	VA-117
21231	VO-86	22295	VA-157	224854	VCA-1048	26028	VA-104	26444	VA-118
21246	VO-70	2230013	VCA-1082	224855	VCA-1159	26035	VA-91	26462	VA-178
21258	VO-108	2230084	VCA-1174	224857	VCA-1068	26036	VA-44	26463	VA-136
21307	VO-95	2230129	VCA-1173	224864	VCA-1168	26040	VA-38	26465	VA-159
21311	VO-95	2230142	VCA-1176	224865	VCA-1029	26044	VA-261	26472	VA-116
21315	VO-118	2230155	VCA-1181	224869	VCA-1043	26051	VFAP-7854	26493	VA-279
21315MP	VO-118	2230192	VCA-1184	22487	VA-259	26057	VA-99	26503	VA-65
21334	VO-106	22329	VA-164	224871	VCA-1037	26064	VA-83	26573	VA-169
21334	VO-106	22333	VA-408	224872	VCA-1030	26077	VA-90	26646	VA-191
21334	VO-52	22341	VA-142	224873	VCA-1028	26080	VA-107	26653	VA-335
21334MP	VO-106	22384	VA-137	224875	VCA-1014	26081	VA-129	26673	VA-163
21342	VO-15	22385	VA-149	224876	VCA-1017	26083	VA-98	26674	VA-166
21342MP	VO-15	22389	VA-154	224877	VCA-1122	26088	VA-269	26677	VA-155
21347	VO-52	224012	VCA-1171	224881	VCA-1139	26093	VA-88	26678	VA-324
21348	VO-25	224013	VCA-1075	224882	VCA-1065	26095	VFAP-7857	26699	VA-156
21348MP	VO-25	224014	VCA-1076	224883	VCA-1014	26097	VA-416	26728	VA-167
21355	VO-93	224015	VCA-1072	224884	VCA-1125	26098	VA-106	26799	VA-132
21356	VO-106	224017	VCA-1073	224893	VCA-1129	26105	VFAP-7893	26802	VA-192
21361	VO-25	224030	VCA-1055	224897	VCA-1013	26108	VA-101	26803	VA-270
21361MP	VO-25	224048	VCA-1077	224899	VCA-1160	26109	VA-125	26804	VA-182
21365	VO-106	224065	VCA-1049	224900	VCA-1042	26116	VA-86	26814	VA-205
21372	VO-88	224068	VCA-1118	224901	VCA-1067	26117	VA-108	26831	VA-183
21372MP	VO-88	224080	VCA-1071	224903	VCA-1170	26120	VA-40	26832	VA-184
21378	VO-60	224103	VCA-1175	224905	VCA-1133	26126	VA-66	26834	VA-171
21381	VO-19	22412	VA-333	224907	VCA-1070	26128	VA-413	26873	VA-206
21391	VO-25	224148	VCA-1116	224909	VCA-2033	26133	VA-69	26879	VA-189
21392	VO-27	224191	VCA-1078C	22524	VA-140	26134	VA-205	26887	VA-175

CAUTION: For general references only. Check catalog for correct filter application. Any use of this interchange to determine filter application is done at the installers risk.
 PRECAUCION: Solamente para referencias generales. Revise el catálogo para la correcta aplicación del filtro. Cualquier uso de la referencia cruzada para determinar la aplicación del filtro es riesgo del instalador. ATTENTION : Seulement pour les références d'ordre général. Contrôler l'application correcte du filtre avec le catalogue. Toute utilisation de moyens afin de déterminer l'application d'un filtre est faite aux risques de l'installateur.

Cross Reference

Table da equivalencias da fabricantes

Code de renvoi au fabricant

MFR'S NUMBER	REPLACEMENT NUMBER	MFR'S NUMBER	REPLACEMENT NUMBER	MFR'S NUMBER	REPLACEMENT NUMBER	MFR'S NUMBER	REPLACEMENT NUMBER	MFR'S NUMBER	REPLACEMENT NUMBER
NAPA PROSELECT		27899	VO-88	49480	VA-334	36273	VFAP-7892	13212-13213	VO-25
26888	VA-195	29000	VA-238	NAPA SILVER		36289	VA-89	15200-W1116	VO-95
26902	VA-176	29005	VA-368	3100290	VO-88	36301	VA-110	15208-AA000	VO-25
26914	VA-198	29009	VA-291	31036	VO-55	36302	VA-109	15208-AA021	VO-106
26917	VA-269	29010	VA-234	31040	VO-16	36303	VA-113	15208-AA022	VO-106
26924	VA-197	29012	VA-198	31042	VO-58	36358	VFAP-7908	15208-ED50A	VO-106
26935	VA-224	29014	VA-290	31060	VO-56	36388	VA-135	15208-G3100	VO-25
26938	VA-314	29016	VA-245	31068	VO-95	36406	VFAP-1643	15208-HA300	VO-136
26975	VA-186	29017	VA-288	31069	VO-65	36416	VA-114	15208-HA301	VO-136
27002	VO-106	29018	VA-258	31085	VO-95	36418	VA-94	15208-HC254	VO-106
27021	VO-66	29020	VA-274	31223	LC-8170	36425	VA-112	15208-HC300	VO-106
27021MP	VO-66	29022	VA-300	31226	VO-69	36440	VA-92	15208-HC400	VO-106
27029	VO-99	29023	VA-278	31315	VO-118	36441	VA-320	15208-HC401	VO-106
27033	VO-73	29031	VA-292	31334	VO-106	36443	VA-117	15208-HG00D	VO-164
27038	VO-69	29038	VA-301	31348	VO-25	36444	VA-118	15208-H1010	VO-25
27041	VO-96	29040	VA-221	31356	VO-106	36472	VA-116	15208-H1011	VO-25
27045	VO-88	29041	VA-220	31361	VO-25	36673	VA-163	15208-H1111	VO-95
27047	VO-84	29042	VA-202	31365	VO-106	36677	VA-155	15208-H8901	VO-25
27055	VO-106	29052	VA-227	31372	VO-88	36699	VA-156	15208-H8903	VO-25
27059	VO-149	29053	VA-216	31394	VO-40	36802	VA-192	15208-H8904	VO-25
27060	VO-88	29057	VA-233	31515	VO-1	36804	VA-182	15208-H8905	VO-25
27060MP	VO-88	29058	VA-252	31516	VO-118	36831	VA-183	15208-H8910	VO-25
27061	VO-90	29063	VA-184	31522	VO-108	36834	VA-171	15208-H8911	VO-25
27064	VO-102	29064	VA-217	31734	VO-63	36888	VA-195	15208-H8911B	VO-25
27073	VO-88	29065	VA-212	32013	VA-181	36902	VA-176	15208-H8912	VO-25
27078	VO-103	29067	VA-213	32020	VA-321	37021	VO-66	15208-H8915	VO-25
27079	VO-78	29069	VA-201	32088	VA-402	37047	VO-84	15208-H8916	VO-25
27082	VO-76	29070	VA-235	32098	VA-2	37060	VO-88	15208-H8917	VO-25
27082MP	VO-76	29073	VA-312	32133	VA-69	37061	VO-90	15208-H8920	VO-15
27083	VO-77	29104	VA-231	32188	VA-196	37064	VO-102	15208-H8993	VO-25
27090	VO-67	29114	VA-215	32329	VA-164	37082	VO-76	15208-H8994	VO-25
27090MP	VO-67	29115	VA-200	32384	VA-137	37090	VO-67	15208-J7525	VO-16
27092	VO-106	29116	VA-251	32385	VA-149	37099	VO-65	15208-KA010	VO-106
27092MP	VO-106	29117	VA-203	32389	VA-154	37145	VO-40	15208-N8912	VO-25
27099	VO-65	29120	VA-237	32472	VA-138	37187	VO-85	15208-N8916	VO-95
27099MP	VO-65	29145	VA-222	32484	VA-162	37202	VO-75	15208-T3153	VO-40
27144	VO-110	29146	VA-289	32487	VA-259	37203	VO-80	15208-W1101	VO-95
27145	VO-40	29155	VA-248	32524	VA-140	37327	VO-91	15208-W1103	VO-95
27151	VO-104	29156	VA-228	32551	VA-193	37356	VO-106	15208-W1106	VO-95
27173	VO-87	29172	VA-209	32564	VA-165	37502	VO-88	15208-W1111	VO-95
27175	VO-112	29175	VA-243	32725	VA-160	37620	VO-64	15208-W1113	VO-95
27186	VO-85	29185	VA-353	32729	VA-161	39115	VA-200	15208-W1115	VO-1
27187	VO-85	29186	VA-226	32797	VA-152	39117	VA-203	15208-W1116	VO-95
27202	VO-75	29191	VA-240	32843	VA-180	39886	VA-239	15208-W1120	VO-1
27202MP	VO-75	29192	VA-229	32844	VA-202	NISSAN		15208-W1123	VO-1
27203	VO-80	29223	VA-214	36017	VA-102	AF54M-30P0JNW	VA-261	15208-W3401	VO-15
27204	VO-92	29225	VA-244	36026	VA-103	AY100-HN022	VO-106	15208-W3403	VO-15
27210	VO-71	29230	VA-275	36027	VA-97	AY100-MT023	VO-106	15208-Y1120	VO-1
27250	VO-99	29250	VA-265	36028	VA-104	AY100-MT024	VO-136	15208-Y7502	VO-15
27262	VO-132	29310	VA-309	36035	VA-91	AY100-NS004	VO-106	15208-13201	VO-15
27302	VO-86	29320	VA-257	36040	VA-38	AY100-NS007	VO-25	15208-13210	VO-15
27303	VO-82	29362	VA-332	36064	VA-83	AY100-NS009	VO-15	15208-13211	VO-15
27311	VO-81	29429	VA-219	36077	VA-90	AY100-NS010	VO-15	15208-13212	VO-15
27314	VO-81	29430	VA-273	36081	VA-129	AY100-NS012	VO-155	15208-13213	VO-15
27327	VO-91	29450	VA-265	36095	VFAP-7857	AY100-TY014	VO-40	15208-20N00	VO-155
27341	VO-116	29460	VA-250	36108	VA-101	AY100-TY015	VO-25	15208-20N01	VO-155
27356	VO-106	29498	VA-263	36109	VA-125	AY100-TY017	VO-15	15208-20N02	VO-155
27356	VO-106	29634	VA-225	36116	VA-86	AY100-TY018	VO-1	15208-20N10	VO-155
27356MP	VO-106	29727	VA-255	36117	VA-108	AY120-NS001	VA-86	15208-21120	VO-1
27462	VO-133	29730	VA-285	36120	VA-40	A5208-H8903	VO-25	15208-3J400	VO-106
27502	VO-88	29737	VA-286	36126	VA-66	B7200-OW010	VCA-1039	15208-31U0B	VO-106
27512	VO-111	29739	VA-296	36134	VA-205	B7200-3Y000	VCA-1096	15208-31U0C	VO-106
27526	VO-110	29750	VA-304	36139	VA-65	B7200-5M000	VCA-1068	15208-31U00	VO-106
27530	VO-40	29756	VA-273	36144	VFAP-917	B727A-79925	VCA-1068	15208-31U01	VO-106
27561	VO-101	29843	VA-318	36153	VA-78	B7277-JN20A	VCA-1038	15208-4A00A	VO-40
27620	VO-64	29883	VA-223	36162	VA-96	B7891-1FC0A	VCA-1171	15208-40L00	VO-155
27620MP	VO-64	29890	VA-241	36174	VA-70	B7891-1FE0A	VCA-1171	15208-40L01	VO-155
27674	VO-98	29893	VA-246	36213	VA-105	12019-000-0000	VO-1	15208-40L02	VO-155
27712	VO-106	29901	VA-267	36244	VA-84	12019-021-2000	VO-1	15208-48916	VO-25
27806	VO-97	29926	VA-154	36253	VA-260	12019-021-2001	VO-1	15208-53J00	VO-147
27830	VO-106	29933	VA-232	36253	VA-322	13210-13211	VO-25	15208-53J01	VO-40

CAUTION: For general references only. Check catalog for correct filter application. Any use of this interchange to determine filter application is done at the installers risk.

PRECAUCION: Solamente para referencias generales. Revise el catálogo para la correcta aplicación del filtro. Cualquier uso de la referencia cruzada para determinar la aplicación del filtro es riesgo del instalador. ATTENTION : Seulement pour les références d'ordre général. Contrôler l'application correcte du filtre avec le catalogue. Toute utilisation de moyens afin de déterminer l'application d'un filtre est faite aux risques de l'installateur.

Cross Reference

Table da equivalencias da fabricantes

Code de renvoi au fabricant

MFR'S NUMBER	REPLACEMENT NUMBER	MFR'S NUMBER	REPLACEMENT NUMBER	MFR'S NUMBER	REPLACEMENT NUMBER	MFR'S NUMBER	REPLACEMENT NUMBER	MFR'S NUMBER	REPLACEMENT NUMBER
NISSAN		16546-3TA0A	VA-312	999M1-VP005	VCA-1048	AF3975	VA-188	AF7828	VA-83
15208-53J10	VO-40	16546-30P00	VA-261	999M1-VP051	VCA-1068	AF3984	VA-198	AF7832	VA-98
15208-55Y00	VO-25	16546-4BA1A	VA-438	999M1-VP055	VCA-1048	AF3992	VA-202	AF7836	VA-101
15208-6F901	VO-52	16546-4BA1B	VA-438	999M1-VR006	VCA-1041	AF3996	VA-209	AF7841	VA-102
15208-6F905	VO-52	16546-4BA2A	VA-438	999M1-VR056	VCA-1041	AF4	VA-321	AF7842	VA-103
15208-60U00	VO-25	16546-4BC1A	VA-438	999M1-VS007	VCA-1034	AF4000	VA-227	AF7843	VA-104
15208-60U01	VO-25	16546-4BC2A	VA-438	PARTS PLUS		AF4001	VA-228	AF7845	VA-105
15208-63100	VO-25	16546-5DD0A	VA-449	AF1031	VA-69	AF4002	VA-210	AF785	VA-44
15208-649501	VO-40	16546-60U00	VA-370	AF1032A	VA-205	AF4004	VA-353	AF7854	VA-404
15208-65F0B	VO-106	16546-7B000	VFAP-7857	AF1042	VA-413	AF4006	VA-362	AF7854	VFAP-7854
15208-65F0C	VO-106	16546-7S000	VA-105	AF1043	VA-66	AF4007	VA-211	AF7857	VFAP-7857
15208-65F0D	VO-106	16546-7QJ10	VA-86	AF1046	VA-70	AF4008	VA-212	AF7858	VA-106
15208-65F0E	VO-106	16546-73C00	VA-261	AF1061	VA-88	AF4009	VA-374	AF7859	VFAP-7859
15208-65F00	VO-106	16546-73C01	VA-261	AF1096	VA-78	AF4010	VA-282	AF7862	VA-107
15208-65F01	VO-106	16546-73C10	VA-261	AF1129	VA-269	AF4011	VA-213	AF7863	VA-108
15208-65F1B	VO-106	16546-73C11	VA-261	AF1236	VA-412	AF4012	VA-229	AF7867	VA-125
15208-65001	VO-1	16546-73000	VA-321	AF1279	VA-91	AF4014	VA-230	AF7872	VA-109
15208-65002	VO-1	16546-74S00	VA-86	AF1300	VA-92	AF4015	VA-231	AF7873	VA-110
15208-65004	VO-1	16546-86G00	VA-97	AF1518	VA-271	AF4017	VA-214	AF7874	VA-89
15208-65005	VO-1	16546-89G00	VA-97	AF1519	VA-259	AF4019	VA-242	AF7877	VA-90
15208-65010	VO-1	16546-89W00	VA-38	AF1612	VFAP-1612	AF4020	VA-343	AF7878	VA-111
15208-65010	VO-1	27222-EG025	VCA-1044	AF1613	VFAP-1613	AF4021	VA-240	AF7879	VA-112
15208-65011	VO-1	27274-EA000	VCA-1041	AF1615	VA-94	AF4022	VA-243	AF7880	VA-113
15208-65011	VO-1	27275-2W625	VCA-1039	AF1624	VA-181	AF4023	VA-244	AF7882	VA-114
15208-65012	VO-1	27277-AR225	VCA-1044	AF1658	VA-260	AF4025	VA-258	AF7884	VA-157
15208-65012	VO-1	27277-CL000	VCA-1068	AF1679	VA-142	AF4026	VA-232	AF7892	VFAP-7892
15208-65014	VO-1	27277-CL025	VCA-1068	AF1688	VA-140	AF4027	VA-252	AF7906	VA-132
15208-65014	VO-1	27277-EG000	VCA-1044	AF1695	VA-162	AF4028	VA-357	AF7908	VFAP-7908
15208-65016	VO-1	27277-EG025	VCA-1044	AF1696	VA-149	AF4029	VA-238	AF7910	VA-129
15208-65601	VO-1	27277-EL00A	VCA-1052	AF1744	VA-322	AF4030	VA-233	AF7911	VA-144
15208-7B000	VO-106	27277-EN000	VCA-1034	AF1754	VA-182	AF4031	VA-234	AF7913	VA-135
15208-7F40A	VO-15	27277-GZ50A	VCA-1068	AF17	VA-402	AF4033	VA-235	AF7914	VA-153
15208-70J00	VO-40	27277-JA00A	VCA-1038	AF2014	VA-161	AF4034	VA-278	AF7917	VA-116
15208-71J00	VO-25	27277-JA00C	VCA-1038	AF2340	VA-175	AF4035	VA-372	AF7919	VA-117
15208-80W00	VO-95	27277-VP00A	VCA-1048	AF2771	VA-197	AF4038	VA-332	AF7920	VA-118
15208-8916	VO-25	27277-VR00A	VCA-1041	AF2883	VA-223	AF4042	VA-236	AF7935	VA-138
15208-9E000	VO-106	27277-VS00A	VCA-1034	AF2884	VA-224	AF4044	VA-221	AF7938	VA-146
15208-9E01A	VO-106	27277-VX01A	VCA-1044	AF293	VA-86	AF4045	VA-220	AF7939	VA-315
15208-9F600	VO-106	27277-YX01A	VCA-1044	AF2956	VA-203	AF4048	VA-245	AF7942	VA-354
15209-J1800	VO-15	27277-1FC0A	VCA-1171	AF2962	VA-200	AF4049	VA-375	AF7946	VA-137
15209-Y1800	VO-15	27277-1KK0A	VCA-2043	AF3054	VA-217	AF4051	VA-294	AF7954	VA-151
15209-Y7500	VO-15	27277-3DF0A	VCA-1171	AF3083	VA-225	AF4052	VA-383	AF7958	VA-270
15209-Y7501	VO-15	27277-3JC1A	VCA-1082	AF3096	VA-263	AF4054	VA-384	AF7959	VA-192
15209-Y7502	VO-15	27277-3JC1B	VCA-1082	AF3128	VA-254	AF4055	VA-250	AF7964	VA-151
15209-10H10	VO-15	27277-3JC1C	VCA-1082	AF3139	VA-296	AF4057	VA-358	AF7965	VA-150
16208-H8920	VO-25	27277-3JC2A	VCA-1082	AF3216	VA-183	AF4058	VA-385	AF7974	VA-166
16546-AR000	VA-370	27277-4BA0A	VCA-1178	AF3219	VA-316	AF4062	VA-268	AF7975	VA-156
16546-DZ000	VA-86	27277-4BU0A	VCA-1178	AF3220	VA-447	AF4063	VA-366	AF7976	VA-346
16546-EA000	VA-356	27277-4M400	VCA-1068	AF3245	VA-184	AF4065	VA-257	AF7977	VA-361
16546-ED000	VA-244	27277-5HA0A	VCA-1178	AF329	VA-403	AF4067	VA-275	AF7981	VA-155
16546-EG000	VA-282	27278-1KK0A	VCA-2043	AF348	VA-2	AF5185	VA-265	AF7984	VA-154
16546-EJ70A	VA-391	27298-7S600	VCA-1048	AF351	VA-84	AF5187	VA-283	AF7990	VA-165
16546-ET00A	VA-238	27299-5Z000	VCA-1159	AF3588	VA-164	AF5190	VA-273	AF7991	VA-170
16546-ET00J	VA-238	27891-EL00A	VCA-1052	AF359	VA-408	AF5200	VA-310	AF7996	VA-169
16546-ET000	VA-238	27891-1FC0A	VCA-1171	AF3590	VA-160	AF5222	VA-304	AF7998	VA-192
16546-EZ31A	VA-470	27891-1FD01	VCA-1171	AF3594	VA-176	AF56	VA-48	AF7999	VA-193
16546-F1800	VA-321	27891-3DF0A	VCA-1171	AF3595	VA-171	AF5694	VA-371	AF89	VA-34
16546-F4101	VA-261	27891-3SG0A	VCA-1171	AF3598	VA-186	AF602	VA-40	AF9010	VA-163
16546-JA00A	VA-233	3R0076150M	VO-106	AF3605	VA-313	AF6103	VA-445	AF9098	VA-196
16546-JA00B	VA-233	31725-1L000	VO-25	AF372	VA-414	AF6149	VA-288	AF917	VFAP-917
16546-JK20A	VA-332	32622-90000	VO-25	AF3896	VA-274	AF6151	VA-287	AF925	VA-85
16546-V0100	VA-86	32622-90002	VO-25	AF3897	VA-318	AF6165	VA-286	AF974	VA-65
16546-V0110	VA-86	32622-9002	VO-25	AF3904	VA-180	AF6171	VA-292	AF9907	VA-331
16546-V01108	VA-86	35622-90002	VO-25	AF3933	VA-204	AF6197	VA-297	AF9911	VA-429
16546-0B000	VFAP-7857	4SAU9601BA	VA-356	AF3936	VA-365	AF6200	VA-300	AF9914	VA-306
16546-0Z000	VA-86	65010-65011	VO-25	AF3940	VA-448	AF6274	VA-307	AF9915	VA-312
16546-1HK0JNW	VA-301	65012-65014	VO-25	AF3954	VA-187	AF697	VA-45	CAF1033	VCA-1096
16546-1HK01	VA-301	999A2-VX000	VCA-1044	AF3955	VA-205	AF773	VA-38	CAF1040	VCA-1146
16546-1P100	VA-370	999M1-VP001	VCA-1068	AF3956	VA-179	AF7816	VA-96	CAF1042	VCA-1041
16546-17B00	VA-261	999M1-VP003	VCA-1039	AF3959	VA-195	AF7825	VA-97	CAF1043	VCA-1048
16546-3J410	VA-261	999M1-VP004	VCA-1096	AF3974	VA-207	AF7826	VA-416	CAF1049	VCA-1031

CAUTION: For general references only. Check catalog for correct filter application. Any use of this interchange to determine filter application is done at the installers risk.
 PRECAUCION: Solamente para referencias generales. Revise el catálogo para la correcta aplicación del filtro. Cualquier uso de la referencia cruzada para determinar la aplicación del filtro es riesgo del instalador. ATTENTION : Seulement pour les références d'ordre général. Contrôler l'application correcte du filtre avec le catalogue. Toute utilisation de moyens afin de déterminer l'application d'un filtre est faite aux risques de l'installateur.

Cross Reference

Table da equivalencias da fabricantes

Code de renvoi au fabricant

MFR'S NUMBER	REPLACEMENT NUMBER	MFR'S NUMBER	REPLACEMENT NUMBER	MFR'S NUMBER	REPLACEMENT NUMBER	MFR'S NUMBER	REPLACEMENT NUMBER	MFR'S NUMBER	REPLACEMENT NUMBER
PARTS PLUS		CAF5654	VCA-1043	PH44*	VO-58	61042BP	VO-58	62101	VA-403
CAF1050	VCA-1069	CAF5659	VCA-1089	PH453	VO-93	61045	VO-108	62116	VA-321
CAF4010	VCA-1145	CAF5660	VCA-1051	PH454*	VO-65	61060	VO-56	62133	VA-69
CAF4012	VCA-1171	CAF5662	VCA-1066	PH47	VO-16	61060BP	VO-56	62164	VA-247
CAF4013	VCA-1075	CAF5667	VCA-1031	PH48	VO-88	61064	VO-106	62177	VFAP-7912
CAF4068	VCA-1118	CAF5668	VCA-1022	PH500	VO-88	61068	VO-95	62181	VA-270
CAF4313	VCA-1069	CAF5674	VCA-1138	PH51A*	VO-55	61068BP	VO-95	62188	VA-196
CAF4479	VCA-1044	CAF5675	VCA-1139	PH561*	VO-15	61069	VO-65	62295	VA-157
CAF4482	VCA-1046	CAF5676	VCA-1065	PH59*	VO-108	61069BP	VO-65	62329	VA-164
CAF4524	VCA-1110	CAF5677	VCA-2033	PH610	VO-101	61085	VO-95	62333	VA-408
CAF4579	VCA-1070	CAF5764	VCA-1041	PH8A*	VO-1	61085BP	VO-95	62341	VA-142
CAF4682	VCA-1113	CAF5836	VCA-1075	PH820	VO-88	61088	VO-15	62384	VA-137
CAF4684	VCA-1047	CAF5840C	VCA-1108	P1072	VO-37	61145	VO-62	62385	VA-149
CAF4685	VCA-1146	CAF5844	VCA-1153	P2129	VO-67	61160	LC-834	62389	VA-154
CAF4725	VCA-1036	CAF5871	VCA-1038	P2224	VO-73	61186	VO-74	62412	VA-333
CAF4753	VCA-1144	CAF5875	VCA-1114	P3040	VO-77	61191	VO-159	62472	VA-138
CAF4761	VCA-1057	CAF6067	VCA-1062	P3244	VO-76	61212	VO-150	62476	VA-146
CAF4854	VCA-1048	CAF6098	VCA-1094	P3969	VO-129	61212-1	VO-150	62479	VA-146
CAF4855	VCA-1159	CAF6099	VCA-1059	P3986	VO-85	61215	VO-25	62484	VA-162
CAF4860	VCA-1157	CAF6115	VCA-1055	P6160	VO-121	61223	LC-8170	62487	VA-259
CAF4863	VCA-1039	CAF6154C	VCA-1078C	P6289	VO-151	61226	VO-69	62488	VA-259
CAF4879	VCA-1054	CAF6174	VCA-1081	P8153	VO-69	61226BP	VO-69	62524	VA-140
CAF4902	VCA-1155	CAF6176	VCA-1077	P8170	LC-8170	61228	VO-86	62551	VA-193
CAF5082	VCA-1001	CAF6185	VCA-1120	P833	LC-833	61231	VO-86	62564	VA-165
CAF5245	VCA-1002	CAF6205C	VCA-1080	P837	VO-66	61246	VO-70	62612	VA-207
CAF5246	VCA-1021	CAF8188	VCA-1042	P842	VO-97	61258	VO-108	62725	VA-160
CAF5383	VCA-1166	CAF8222	VCA-1067	P843	VO-62	61311	VO-95	62728	VA-150
CAF5384	VCA-1017	CAF9093	VCA-1093	P856	VO-71	61315	VO-118	62729	VA-161
CAF5387	VCA-1163	CAF9353	VCA-1050	P907	VO-138	61334	VO-106	62740	VA-172
CAF5388	VCA-1003	CAF9366	VCA-1142	P960	VO-80	61334	VO-106	62750	VA-179
CAF5389	VCA-1008	G16	VG-2	P961	VO-94	61334BP	VO-106	62793	VA-149
CAF5390	VCA-1167	G481	VG-14	P966	VO-92	61334BP	VO-106	62797	VA-152
CAF5402	VCA-1122	G578	VG-33	P967	VO-84	61334BP	VO-52	62799	VA-199
CAF5425	VCA-1060	G580	VG-30	P968	VO-87	61342	VO-15	62800	VA-355
CAF5426	VCA-1024	G6367	VG-32	P969	VO-91	61348	VO-25	62825	VA-190
CAF5439	VCA-1012	G800	VG-16	P972	VO-90	61348BP	VO-25	62831	VA-188
CAF5448	VCA-1022	LAF1520	VA-324	P980	VO-102	61355	VO-93	62834	VA-208
CAF5459	VCA-1013	LAF1617	VA-93	P981	VO-98	61356	VO-106	62839	VA-337
CAF5471	VCA-1164	LAF1646	VA-174	P982	VO-99	61356BP	VO-106	62843	VA-180
CAF5473	VCA-1123	LAF1680	VA-122	P989	VO-109	61361	VO-25	62844	VA-202
CAF5477	VCA-1165	LAF3141	VA-295	P990	VO-110	61365	VO-106	62846	VA-177
CAF5478	VCA-1020	LAF5028	VA-349	P993	VO-116	61372	VO-88	62859	VA-204
CAF5479	VCA-1014	LAF5980	VA-177	PARTSMaster (NEW)		61372BP	VO-88	62864	VA-336
CAF5480	VCA-1029	LAF6902	VA-266	WA610008	VA-303	61378	VO-144	62885	VA-194
CAF5483	VCA-1161	LAF9096	VA-167	WA610048	VA-306	61381	VO-19	62891	VA-151
CAF5484	VCA-1124	LFP2051	VO-104	WA610058	VA-437	61391	VO-25	62972	VA-325
CAF5490	VCA-1030	LFP2286	VO-63	WA610095	VA-298	61392	VO-27	62993	VA-48
CAF5491	VCA-1028	LFP2999	VO-75	WA610096	VA-434	61393	VO-15	66006	VFAP-7859
CAF5494	VCA-1168	LFP780	VO-64	WA610127	VA-417	61393BP	VO-15	66017	VA-102
CAF5498	VCA-1125	LP2017	VO-81	WA610212	VA-432	61394	VO-40	66026	VA-103
CAF5504	VCA-1106	PH1218	VO-56	WA610215	VA-438	61394BP	VO-40	66027	VA-97
CAF5506	VCA-1160	PH2005*	VO-118	WA610255	VA-424	61396	VO-40	66028	VA-104
CAF5508	VCA-1040	PH2008	VO-86	WA610256	VA-425	61515	VO-1	66035	VA-91
CAF5509	VCA-1127	PH2009	VO-86	WA610268	VA-453	61516	VO-118	66036	VA-44
CAF5510	VCA-1162	PH24	VO-108	WA610269	VA-431	61516BP	VO-118	66040	VA-38
CAF5516	VCA-1106	PH253	VO-95	WA610271	VA-418	61521	VO-95	66043	VA-408
CAF5518	VCA-1129	PH2702	VO-60	WA610315	VA-430	61522	VO-108	66044	VA-261
CAF5519	VCA-1063	PH2801	VO-35	WL610010	VO-114	61522BP	VO-108	66051	VFAP-7854
CAF5526	VCA-1125	PH2808	VO-106	WL610024	VO-117	61607	VO-64	66057	VA-99
CAF5527	VCA-1074	PH2815	VO-15	WL610060	VO-142	61626	VO-35	66058	VA-158
CAF5530	VCA-1068	PH2817	VO-27	WL610255	VO-88	61630	VO-37	66064	VA-83
CAF5537	VCA-1056	PH2827	VO-25	WL610290	VO-200	61734	VO-63	66077	VA-90
CAF5549	VCA-1133	PH2835	VO-25	WL610332	VO-175	61734BP	VO-63	66080	VA-107
CAF5571	VCA-1101	PH2840	VO-40	43484	VG-30	61742	VO-46	66081	VA-129
CAF5572	VCA-1102	PH2856A*	VO-19	470	VA-255	62013	VA-181	66083	VA-98
CAF5576	VCA-1134	PH2867	VO-106	49737	VA-286	62015	VA-147	66088	VA-269
CAF5599	VCA-1170	PH2869	VO-106	61036	VO-55	62020	VA-321	66093	VA-88
CAF5621	VCA-1172	PH2876	VO-106	61036BP	VO-55	62086	VA-185	66095	VFAP-7857
CAF5624C	VCA-1103	PH2903	VO-52	61040	VO-16	62088	VA-402	66097	VA-416
CAF5643	VCA-1070	PH2904	VO-95	61040BP	VO-16	62096	VA-45	66098	VA-106
CAF5644	VCA-1037	PH400*	VO-118	61042	VO-58	62098	VA-2	66105	VFAP-7893

CAUTION: For general references only. Check catalog for correct filter application. Any use of this interchange to determine filter application is done at the installers risk.

PRECAUCION: Solamente para referencias generales. Revise el catálogo para la correcta aplicación del filtro. Cualquier uso de la referencia cruzada para determinar la aplicación del filtro es riesgo del instalador. ATTENTION : Seulement pour les références d'ordre général. Contrôler l'application correcte du filtre avec le catalogue. Toute utilisation de moyens afin de déterminer l'application d'un filtre est faite aux risques de l'installateur.

Cross Reference

Table da equivalencias da fabricantes

Code de renvoi au fabricant

MFR'S NUMBER	REPLACEMENT NUMBER	MFR'S NUMBER	REPLACEMENT NUMBER	MFR'S NUMBER	REPLACEMENT NUMBER	MFR'S NUMBER	REPLACEMENT NUMBER	MFR'S NUMBER	REPLACEMENT NUMBER
PARTSMASER (NEW)		66699	VA-156	67561	VO-101	69210	VA-283	94203	VCA-1061
66108	VA-101	66728	VA-167	67620	VO-64	69223	VA-214	94211	VCA-1183
66109	VA-125	66799	VA-132	67674	VO-98	69225	VA-244	94212	VCA-1110
66116	VA-86	66802	VA-192	67712	VO-106	69230	VA-275	94300	VCA-1062
66117	VA-108	66803	VA-270	67806	VO-97	69247	VA-302	94302	VCA-1097
66120	VA-40	66804	VA-182	67830	VO-106	69250	VA-265	94313	VCA-1069
66126	VA-66	66814	VA-205	67899	VO-88	69288	VA-299	94367	VCA-1059
66128	VA-413	66831	VA-183	69000	VA-238	69293	VA-354	94400	VCA-1038
66133	VA-69	66832	VA-184	69001	VA-282	69310	VA-309	94419	VCA-1081
66134	VA-205	66834	VA-171	69004	VA-358	69320	VA-257	94473	VCA-1162
66139	VA-65	66873	VA-206	69005	VA-368	69344	VA-315	94474	VCA-1022K
66144	VFAP-917	66879	VA-189	69009	VA-291	69362	VA-332	94475	VCA-1134
66153	VA-78	66887	VA-175	69010	VA-234	69400	VA-268	94477	VCA-1101
66153-1	VA-78	66888	VA-195	69012	VA-198	69429	VA-219	94479	VCA-1044
66162	VA-96	66902	VA-176	69014	VA-290	69430	VA-273	94482	VCA-1046
66174	VA-70	66914	VA-198	69016	VA-245	69450	VA-265	94483	VCA-1031
66180	VA-85	66916	VA-356	69018	VA-258	69460	VA-250	94484	VCA-1138
66195	VA-144	66917	VA-269	69020	VA-274	69475	VA-457	94488	VCA-1031
66213	VA-105	66924	VA-197	69022	VA-300	69480	VA-334	94489	VCA-1135
66215	VA-153	66935	VA-224	69023	VA-278	69498	VA-263	94495	VCA-1043
66242	VA-414	66938	VA-314	69031	VA-292	69530	VA-297	94517	VCA-1035
66244	VA-84	66975	VA-186	69038	VA-301	69590	VA-426	94567	VCA-1031
66253	VA-260	67002	VO-106	69040	VA-221	69604	VA-284	94577	VCA-1031
66253-1	VA-322	67021	VO-66	69041	VA-220	69610	VA-390	94579	VCA-1064
66255	VA-260	67021BP	VO-66	69042	VA-202	69630	VA-307	94600	VCA-1115
66271	VA-411	67029	VO-99	69043	VA-313	69634	VA-225	94682	VCA-1113
66272	VA-387	67033	VO-73	69049	VA-287	69670	VA-311	94683	VCA-1041
66272	VA-111	67038	VO-69	69051	VA-328	69727	VA-255	94684	VCA-1047
66273	VFAP-7892	67041	VO-96	69052	VA-227	69730	VA-285	94685	VCA-1146
66288	VFAP-7859	67045	VO-88	69053	VA-216	69737	VA-286	94686	VCA-1106
66289	VA-89	67047	VO-84	69055	VA-212	69739	VA-296	94687	VCA-1102
66293	VA-111	67050	VO-109	69056	VA-323	69746	VA-293	94688	VCA-1172
66301	VA-110	67055	VO-106	69057	VA-233	69750	VA-304	94689	VCA-1050
66302	VA-109	67059	VO-149	69058	VA-252	69756	VA-273	94725	VCA-1036
66303	VA-113	67060	VO-88	69063	VA-184	69760	VA-305	94753	VCA-1144
66316	VA-412	67061	VO-90	69064	VA-217	69825	VA-326	94756	VCA-1147
66318	VA-131	67062	VO-129	69065	VA-212	69843	VA-318	94761	VCA-1057
66320	VFAP-7865	67064	VO-102	69067	VA-213	69883	VA-223	94765	VCA-1124
66322	VA-170	67078	VO-103	69069	VA-201	69886	VA-239	94771	VCA-1157
66327	VA-124	67079	VO-78	69070	VA-235	69888	VA-373	94773	VCA-1001
66339	VFAP-1613	67082	VO-76	69073	VA-312	69890	VA-241	94780	VCA-1002
66340	VA-346	67082BP	VO-76	69085	VA-374	69893	VA-246	94782	VCA-1167
66349	VFAP-1612	67083	VO-77	69086	VA-242	69894	VA-254	94794	VCA-1053
66358	VFAP-7908	67090	VO-67	69102	VA-236	69901	VA-267	94805	VCA-1003
66388	VA-135	67092	VO-106	69104	VA-231	69907	VA-341	94807	VCA-1008
66390	VA-120	67092BP	VO-106	69113	VA-230	69926	VA-154	94808	VCA-1163
66398	VA-338	67099	VO-65	69114	VA-215	69933	VA-232	94811	VCA-1021
66406	VFAP-1643	67099BP	VO-65	69115	VA-200	73046	VG-2	94812	VCA-1022
66416	VA-114	67145	VO-40	69116	VA-251	73097	VG-16	94813	VCA-1165
66417	VA-93	67151	VO-104	69117	VA-203	73296	VG-32	94814	VCA-1074
66418	VA-94	67173	VO-87	69119	VA-210	73311	VG-33	94814	VCA-1169
66419	VFA-1641	67175	VO-112	69120	VA-237	73481	VG-14	94815	VCA-1063
66425	VA-112	67186	VO-85	69123	VA-357	73484	VG-30	94816	VCA-1020
66428	VA-404	67187	VO-85	69143	VA-448	81064	VO-106	94817	VCA-1012
66440	VA-92	67202	VO-75	69145	VA-222	88365	VO-106	94818	VCA-1040
66443	VA-117	67203	VO-80	69146	VA-289	94012	VCA-1171	94821	VCA-1161
66444	VA-118	67204	VO-92	69146	VA-382	94013	VCA-1075	94822	VCA-1026
66462	VA-178	67210	VO-71	69155	VA-248	94014	VCA-1076	94823	VCA-1096
66463	VA-136	67250	VO-99	69156	VA-228	94015	VCA-1072	94823	VCA-1096
66465	VA-159	67262	VO-132	69157	VA-343	94017	VCA-1073	94826	VCA-1089
66472	VA-116	67302	VO-86	69158	VA-296	94030	VCA-1055	94827	VCA-1156
66493	VA-279	67303	VO-82	69172	VA-209	94046	VCA-1094	94829	VCA-1052
66503	VA-65	67314	VO-81	69175	VA-243	94048	VCA-1077	94853	VCA-1139
66573	VA-169	67327	VO-91	69180	VA-247	94065	VCA-1049	94854	VCA-1048
66646	VA-191	67341	VO-116	69185	VA-353	94068	VCA-1118	94855	VCA-1159
66653	VA-335	67356	VO-106	69186	VA-226	94080	VCA-1071	94857	VCA-1068
66659	VA-114	67462	VO-133	69187	VA-249	94118	VCA-1106	94863	VCA-1039
66673	VA-163	67502	VO-88	69191	VA-240	94148	VCA-1116	94864	VCA-1168
66674	VA-166	67512	VO-111	69192	VA-229	94191	VCA-1078C	94865	VCA-1029
66677	VA-155	67526	VO-110	69200	VA-294	94200	VCA-1109	94866	VCA-1123
66678	VA-324	67530	VO-40	69201	VA-253	94201	VCA-1061	94868	VCA-1164

CAUTION: For general references only. Check catalog for correct filter application. Any use of this interchange to determine filter application is done at the installers risk.
 PRECAUCION: Solamente para referencias generales. Revise el catálogo para la correcta aplicación del filtro. Cualquier uso de la referencia cruzada para determinar la aplicación del filtro es riesgo del instalador. ATTENTION : Seulement pour les références d'ordre général. Contrôler l'application correcte du filtre avec le catalogue. Toute utilisation de moyens afin de déterminer l'application d'un filtre est faite aux risques de l'installateur.

Cross Reference

Table da equivalencias da fabricantes

Code de renvoi au fabricant

MFR'S NUMBER	REPLACEMENT NUMBER	MFR'S NUMBER	REPLACEMENT NUMBER	MFR'S NUMBER	REPLACEMENT NUMBER	MFR'S NUMBER	REPLACEMENT NUMBER	MFR'S NUMBER	REPLACEMENT NUMBER
PARTSMASTER (NEW)									
94869	VCA-1043	PZA-188	VA-114	PZA-268	VA-162	PZA-558	VA-202	PZ-154	VO-77
94871	VCA-1037	PZA-189	VA-108	PZA-269	VA-161	PZA-559	VA-343	PZ-156	VO-81
94872	VCA-1030	PZA-190	VA-107	PZA-270	VA-110	PZA-560	VA-278	PZ-159	VO-80
94873	VCA-1028	PZA-191	VA-106	PZA-271	VA-144	PZA-561	VA-245	PZ-16	VO-19
94875	VCA-1014	PZA-192	VA-103	PZA-272	VA-160	PZA-570	VA-267	PZ-161	VO-84
94876	VCA-1017	PZA-193	VA-97	PZA-28	VA-164	PZA-571	VA-265	PZ-162	VO-85
94877	VCA-1122	PZA-196	VFAP-917	PZA-396	VFAP-7912	PZA-574	VA-92	PZA-574	VO-91
94878	VCA-1060	PZA-197	VA-104	PZA-407	VA-153	PZA-580	VA-280	PZ-165	VO-87
94879	VCA-1054	PZA-198	VFAP-7859	PZA-432	VA-270	PZA-582	VA-284	PZ-166	VO-103
94881	VCA-1139	PZA-199	VA-113	PZA-433	VA-171	PZA-583	VA-285	PZ-167	VO-88
94882	VCA-1065	PZA-200	VA-112	PZA-434	VA-176	PZA-584	VA-288	PZ-169	VO-96
94883	VCA-1014	PZA-201	VA-93	PZA-439	VA-193	PZA-585	VA-286	PZ-170	VO-81
94884	VCA-1125	PZA-202	VFAP-7857	PZA-442	VA-196	PZA-586	VA-254	PZ-171	VO-98
94893	VCA-1129	PZA-203	VA-111	PZA-443	VA-192	PZA-587	VA-290	PZ-172	VO-102
94894	VCA-1024	PZA-204	VA-320	PZA-447	VA-172	PZA-588	VA-291	PZ-173	VO-88
94897	VCA-1013	PZA-206	VA-94	PZA-450	VA-183	PZA-589	VA-253	PZ-174	VO-99
94899	VCA-1160	PZA-207	VFAP-1643	PZA-451	VA-184	PZA-590	VA-292	PZ-175	VO-101
94900	VCA-1042	PZA-208	VA-260	PZA-452	VA-247	PZA-591	VA-293	PZ-176	VO-103
94901	VCA-1067	PZA-209	VA-69	PZA-454	VA-177	PZA-592	VA-295	PZ-177	VO-104
94902	VCA-1155	PZA-210	VFA-1641	PZA-458	VA-195	PZA-593	VA-296	PZ-178	VO-97
94903	VCA-1170	PZA-211	VA-99	PZA-459	VA-206	PZA-595	VA-298	PZ-179	VO-109
94905	VCA-1133	PZA-212	VA-120	PZA-462	VA-182	PZA-596	VA-299	PZ-18A	VO-27
94907	VCA-1070	PZA-214	VFAP-7908	PZA-465	VA-174	PZA-597	VA-300	PZ-180	VO-110
94909	VCA-2033	PZA-216	VA-125	PZA-468	VA-179	PZA-599	VA-303	PZ-181	VO-85
99093	VCA-1093	PZA-217	VA-91	PZA-469	VA-181	PZA-600	VA-304	PZ-182	VO-106
99101	VCA-1061	PZA-218	VFAP-1612	PZA-473	VA-186	PZA-601	VA-305	PZ-183	VO-111
99352	VCA-1034	PZA-219	VA-135	PZA-474	VA-197	PZA-602	VA-306	PZ-184	VO-114
99353	VCA-1050	PZA-220	VFAP-7859	PZA-475	VA-180	PZA-603	VA-308	PZ-185	VO-117
99355	VCA-1158	PZA-221	VA-338	PZA-476	VA-269	PZA-608	VA-307	PZ-186	VO-116
99357	VCA-1153	PZA-223	VA-387	PZA-478	VA-200	PZA-610	VA-309	PZ-188	VO-123
99359	VCA-1114	PZA-224	VFAP-1613	PZA-479	VA-215	PZA-611	VA-302	PZ-189	VO-142
99371	VCA-1103	PZA-226	VA-412	PZA-481	VA-202	PZA-612	VA-311	PZ-19	VO-118
99372	VCA-1127	PZA-227	VA-129	PZA-484	VA-188	PZA-613	VA-312	PZ-190	VO-115
99377	VCA-1051	PZA-228	VFAP-7893	PZA-485	VA-209	PZA-614	VA-310	PZ-191	VO-92
99466	VCA-1104	PZA-232	VA-132	PZA-486	VA-184	PZA-615	VA-393	PZ-192	VO-149
99700	VCA-1117	PZA-233	VA-117	PZA-487	VA-198	PZA-618	VA-427	PZ-193	VO-164
PENNZOIL									
PHB5572	VCA-1102	PZA-235	VA-118	PZA-488	VA-208	PZA-619	VA-326	PZ-195	VO-174
PZA-108	VA-38	PZA-237	VA-271	PZA-500	VA-217	PZA-620	VA-313	PZ-196	VO-166
PZA-109	VA-44	PZA-238	VA-124	PZA-501	VA-244	PZA-621	VA-429	PZ-197	VO-175
PZA-11	VA-2	PZA-239	VA-122	PZA-504	VA-233	PZA-622	VA-296	PZ-2	VO-108
PZA-117	VA-69	PZA-240	VA-138	PZA-505	VA-213	PZA-623	VA-426	PZ-20	VO-19
PZA-120	VA-45	PZA-240	VA-144	PZA-506	VA-229	PZA-624	VA-314	PZ-21	VO-25
PZA-123	VA-40	PZA-241	VA-137	PZA-507	VA-201	PZA-625	VA-317	PZ-22	VO-15
PZA-130	VA-411	PZA-242	VA-140	PZA-508	VA-212	PZA-626	VA-428	PZ-23	VO-106
PZA-137	VA-65	PZA-243	VA-78	PZA-509	VA-231	PZA-628	VA-431	PZ-25	VO-19
PZA-138	VA-66	PZA-244	VA-149	PZA-510	VA-210	PZA-629	VA-434	PZ-26	VO-40
PZA-139	VA-205	PZA-245	VA-131	PZA-511	VA-251	PZA-630	VA-438	PZ-27	VO-25
PZA-142	VA-70	PZA-246	VA-410	PZA-511	VA-224	PZA-631	VA-440	PZ-28	VO-108
PZA-145	VA-413	PZA-247	VA-136	PZA-514	VA-340	PZA-632	VA-308	PZ-29	VO-55
PZA-148	VA-85	PZA-248	VA-150	PZA-515	VA-227	PZA-633	VA-417	PZ-3	VO-65
PZA-15	VA-403	PZA-249	VA-147	PZA-516	VA-222	PZA-634	VA-284	PZ-30	VO-35
PZA-150	VA-90	PZA-250	VA-146	PZA-517	VA-218	PZA-635	VA-430	PZ-31	VO-37
PZA-153	VA-86	PZA-251	VA-178	PZA-518	VA-223	PZA-636	VA-425	PZ-32	VO-106
PZA-155	VA-269	PZA-252	VA-157	PZA-521	VA-214	PZA-637	VA-432	PZ-32	VO-106
PZA-161	VA-414	PZA-253	VA-270	PZA-522	VA-154	PZA-638	VA-462	PZ-33	VO-106
PZA-162	VA-78	PZA-254	VA-152	PZA-523	VA-203	PZA-640	VA-464	PZ-34	VO-95
PZA-163	VA-88	PZA-255	VA-169	PZA-528	VA-207	PZA-642	VA-418	PZ-35	VO-15
PZA-168	VA-84	PZA-257	VA-154	PZA-532	VA-239	PZA-7	VA-321	PZ-36	VO-106
PZA-169	VA-408	PZA-258	VA-151	PZA-533	VA-252	PZB-3	VA-34	PZ-37	VO-106
PZA-172	VA-83	PZA-259	VA-165	PZA-535	VA-234	PZB-4	VA-48	PZ-38	VO-40
PZA-175	VA-101	PZA-26	VA-109	PZA-539	VA-241	PZ-1	VO-1	PZ-39	VO-40
PZA-177	VA-96	PZA-260	VA-167	PZA-540	VA-226	PZ-10	VO-108	PZ-41	VO-60
PZA-178	VA-416	PZA-261	VFAP-7865	PZA-541	VA-221	PZ-104	VO-95	PZ-41A	VO-60
PZA-179	VA-102	PZA-262	VA-155	PZA-543	VA-225	PZ-105	VO-46	PZ-42	VO-88
PZA-180	VFAP-7854	PZA-263	VA-163	PZA-552	VA-332	PZ-106	VO-19	PZ-45	VO-56
PZA-181	VFAP-7892	PZA-264	VA-156	PZA-553	VA-266	PZ-108	VO-106	PZ-46	VO-106
PZA-184	VA-98	PZA-265	VA-142	PZA-555	VA-258	PZ-109	VO-106	PZ-47	VO-64
PZA-186	VA-105	PZA-266	VA-160	PZA-556	VA-264	PZ-12	VO-15	PZ-48	VO-58
PZA-187	VA-89	PZA-267	VA-170	PZA-557	VA-202	PZ-14	VO-52	PZ-49	VO-63
					VA-263	PZ-15	VO-55	PZ-5	VO-56

CAUTION: For general references only. Check catalog for correct filter application. Any use of this interchange to determine filter application is done at the installers risk.

PRECAUCION: Solamente para referencias generales. Revise el catálogo para la correcta aplicación del filtro. Cualquier uso de la referencia cruzada para determinar la aplicación del filtro es riesgo del instalador. ATTENTION : Seulement pour les références d'ordre général. Contrôler l'application correcte du filtre avec le catalogue. Toute utilisation de moyens afin de déterminer l'application d'un filtre est faite aux risques de l'installateur.

Cross Reference

Table da equivalencias da fabricantes

Code de renvoi au fabricant

MFR'S NUMBER	REPLACEMENT NUMBER	MFR'S NUMBER	REPLACEMENT NUMBER	MFR'S NUMBER	REPLACEMENT NUMBER	MFR'S NUMBER	REPLACEMENT NUMBER	MFR'S NUMBER	REPLACEMENT NUMBER
PENNZOIL		PA6690	VA-96	PABT2053	VA-294	PAB326	VA-2	PAB8037	VA-320
PZ-50	VO-95	PA6807	VA-83	PABT2054	VA-250	PAB327	VA-403	PAB8038	VA-92
PZ-51	VO-118	PA7094	VA-101	PABT2055	VA-368	PAB3492	VA-45	PAB8039	VA-94
PZ-52	VO-65	PA7174	VA-103	PABT2056	VA-445	PAB3501	VA-411	PAB8040	VFAP-7908
PZ-53	VO-62	PA7351	VA-102	PABT2057	VA-375	PAB352	VA-97	PAB8069	VA-144
PZ-54	VO-70	PA7365	VFAP-7854	PABT2059	VA-385	PAB3559	VA-40	PAB8121	VA-147
PZ-55	VO-67	PA7414	VA-107	PAB10013	VA-202	PAB3588	VA-38	PAB8121B	VA-208
PZ-56	VO-73	PA7420	VA-113	PAB10014	VA-200	PAB3647	VA-44	PAB8127	VA-412
PZ-57	VO-86	PA7421	VA-108	PAB10015	VA-210	PAB3660	VA-69	PAB8133	VA-117
PZ-58	VO-76	PA7426	VA-106	PAB10064	VA-377	PAB3681	VA-85	PAB8141	VFA-1641
PZ-59	VO-75	PA7440	VA-105	PAB10071	VA-382	PAB3901	VA-90	PAB8142	VFAP-1643
PZ-60	VO-69	PA7597	VA-109	PAB10083	VA-228	PAB3902	VA-85	PAB8162	VA-131
PZ-61	VO-150	PA7598	VA-110	PAB10084	VA-227	PAB3914	VFAP-917	PAB8188	VA-148
PZ-62	VO-66	PA7774	VA-114	PAB10085	VA-226	PAB3916	VA-65	PAB8205	VA-129
PZ-63	LC-8170	PA8004	VA-94	PAB10086	VA-208	PAB3997	VA-401	PAB8208	VA-153
PZ-64	VO-71	PA8038	VA-92	PAB10088	VA-201	PAB4309	VA-86	PAB8221	VA-91
PZ-65	VO-93	PA8040	VFAP-7908	PAB10092	VA-216	PAB4576	VA-389	PAB8243	VA-260
PZ-7	VO-95	PA8142	VFAP-1643	PAB10093	VA-217	PAB4939	VA-408	PAB8269	VA-410
PZ-8	VO-15	PA8221	VA-91	PAB10094	VA-215	PAB5056	VA-205	PAB8295	VA-347
PZ-9	VO-16	PA8243	VA-260	PAB10110	VA-225	PAB5057	VA-413	PAB8475	VA-118
PZ-9A	VO-16	PN13	VO-56	PAB10118	VA-229	PAB5058	VA-66	PAB8547	VA-136
PENNZOIL PLATINUM		PN16	VO-95	PAB10159	VA-163	PAB5125	VA-414	PAB8548	VA-178
HPZ-12	VO-15	PN2	VO-88	PAB10161	VA-218	PAB5350	VFAP-7865	PAB8601	VA-397
HPZ-161	VO-84	PN2825	VO-15	PAB10163	VA-248	PAB5466	VFAP-7892	PAB8602	VA-138
HPZ-162	VO-85	PN2849A	VO-52	PAB10165	VA-212	PAB5595	VFAP-7893	PAB8606	VA-116
HPZ-167	VO-88	PN2870A	VO-15	PAB10169	VA-209	PAB6366	VA-70	PAB8612	VA-339
HPZ-170	VO-81	PN30	VO-65	PAB10170	VA-249	PAB6395	VA-84	PAB8613	VA-159
HPZ-172	VO-102	PN3387A	VO-16	PAB10171	VA-214	PAB6479	VA-78	PAB8636	VA-146
HPZ-173	VO-88	PN3429	VO-108	PAB10173	VA-222	PAB6555	VA-88	PAB8713	VA-350
HPZ-174	VO-99	PN3506	VO-58	PAB10190	VA-231	PAB6626	VA-269	PAB8720	VA-394
HPZ-177	VO-104	PN3531	VO-27	PAB10191	VA-243	PAB6690	VA-96	PAB8747	VA-156
HPZ-182	VO-106	PN3593A	VO-106	PAB10192	VA-213	PAB6807	VA-83	PAB8754	VA-78
HPZ-19	VO-118	PN3593A	VO-106	PAB10193	VA-340	PAB6821	VA-158	PAB8755	VA-324
HPZ-21	VO-25	PN3600	VO-118	PAB10228	VA-232	PAB6828	VA-416	PAB8760	VA-270
HPZ-28	VO-108	PN3614	VO-25	PAB10233	VA-242	PAB6849	VA-370	PAB8766	VA-152
HPZ-29	VO-55	PN3675	VO-108	PAB10234	VA-244	PAB6850	VA-97	PAB8801	VA-114
HPZ-37	VO-106	PN3682	VO-25	PAB10242	VA-224	PAB6900	VA-261	PAB8805	VA-137
HPZ-38	VO-40	PN3766	VO-46	PAB10254	VA-356	PAB7094	VA-101	PAB8817	VA-164
HPZ-47	VO-64	PN3950	VO-19	PAB10255	VA-386	PAB7142	VA-99	PAB8911	VA-165
HPZ-48	VO-58	PN3970	VO-37	PAB10256	VA-318	PAB7167	VA-98	PAB8918	VA-146
HPZ-49	VO-63	PN3976	VO-64	PAB10261	VA-264	PAB7174	VA-103	PAB8922	VA-190
HPZ-52	VO-65	PN3980	VO-55	PAB10262	VA-223	PAB7246	VA-395	PAB8925	VA-122
HPZ-55	VO-67	PN3985	VO-35	PAB10271	VA-230	PAB7344	VA-104	PAB8927	VA-166
HPZ-57	VO-86	PN43	VO-95	PAB10286	VA-374	PAB7351	VA-102	PAB8956	VA-142
HPZ-58	VO-76	PN4386	VO-40	PAB10343	VA-234	PAB7365	VFAP-7854	PAB8969	VA-140
HPZ-59	VO-75	PN4967	VO-40	PAB10344	VA-252	PAB7414	VA-107	PAB8970	VA-166
HPZ-9A	VO-16	PN5	VO-56	PAB10346	VA-238	PAB7417	VFAP-7859	PAB8997	VA-149
PENSKE		PN5343	VO-106	PAB10347	VA-289	PAB7420	VA-113	PAB9007	VFAP-7865
PA160	VA-321	PN6552	VO-60	PAB10348	VA-258	PAB7421	VA-108	PAB9053	VA-155
PA192	VA-402	PN6607	VO-106	PAB10349	VA-233	PAB7426	VA-106	PAB9054	VA-154
PA326	VA-2	PN7317	VO-106	PAB10359	VA-237	PAB7431	VA-124	PAB9055	VA-345
PA327	VA-403	PN8A	VO-1	PAB10465	VA-255	PAB7432	VA-112	PAB9073	VA-333
PA3492	VA-45	PN8316	VO-118	PAB10466	VA-219	PAB7438	VA-93	PAB9113	VA-150
PA3501	VA-411	PENTIUS		PAB10467	VA-221	PAB7440	VA-105	PAB9115	VA-191
PA3559	VA-40	PABT007	VA-197	PAB10468	VA-220	PAB7597	VA-109	PAB9269	VA-169
PA3588	VA-38	PABT010	VA-227	PAB10470	VA-235	PAB7598	VA-110	PAB9277	VA-346
PA3647	VA-44	PABT011	VA-330	PAB10488	VA-241	PAB7600	VA-338	PAB9286	VA-151
PA3660	VA-69	PABT012	VA-340	PAB10490	VA-343	PAB7605	VA-128	PAB9288	VA-90
PA3901	VA-90	PABT013	VA-386	PAB10497	VA-278	PAB7614	VA-120	PAB9332	VA-162
PA3902	VA-85	PABT2037	VA-343	PAB10539	VA-240	PAB7620	VA-132	PAB9345	VA-161
PA3916	VA-65	PABT2038	VA-383	PAB10542	VA-282	PAB7626	VA-125	PAB9359	VA-170
PA4309	VA-86	PABT2039	VA-358	PAB10544	VA-332	PAB7628	VFAP-7857	PAB9360	VA-163
PA4939	VA-408	PABT2040	VA-372	PAB10551	VA-351	PAB7630	VA-387	PAB9361	VA-192
PA5056	VA-205	PABT2041	VA-384	PAB10578	VA-357	PAB7640	VA-111	PAB9379	VA-279
PA5058	VA-66	PABT2042	VA-268	PAB10591	VA-375	PAB7651	VA-157	PAB9392	VA-193
PA5466	VFAP-7892	PABT2044	VA-154	PAB10693	VA-316	PAB7730	VA-89	PAB9400	VA-167
PA6366	VA-70	PABT2045	VA-278	PAB10867	VA-296	PAB7737	VFAP-1613	PAB9401	VA-160
PA6395	VA-84	PABT2047	VA-362	PAB11042	VA-291	PAB7738	VFAP-1612	PAB9441	VA-172
PA6479	VA-78	PABT2049	VA-353	PAB11113	VA-292	PAB7764	VA-135	PAB9459	VA-335
PA6555	VA-88	PABT2050	VA-184	PAB160	VA-321	PAB7774	VA-114	PAB9471	VA-342
PA6626	VA-269	PABT2052	VA-202	PAB192	VA-402	PAB8014	VFAP-7912	PAB9481	VA-270

CAUTION: For general references only. Check catalog for correct filter application. Any use of this interchange to determine filter application is done at the installers risk.

PRECAUCION: Solamente para referencias generales. Revise el catálogo para la correcta aplicación del filtro. Cualquier uso de la referencia cruzada para determinar la aplicación del filtro es riesgo del instalador. ATTENTION : Seulement pour les références d'ordre général. Contrôler l'application correcte du filtre avec le catalogue. Toute utilisation de moyens afin de déterminer l'application d'un filtre est faite aux risques de l'installateur.

Cross Reference

Table da equivalencias da fabricantes

Code de renvoi au fabricant

MFR'S NUMBER	REPLACEMENT NUMBER	MFR'S NUMBER	REPLACEMENT NUMBER	MFR'S NUMBER	REPLACEMENT NUMBER	MFR'S NUMBER	REPLACEMENT NUMBER	MFR'S NUMBER	REPLACEMENT NUMBER
PENTIUS		PCB8481	VO-69	PHB5510	VCA-1162	PLB3506	VO-58	PA-19	VA-402
PAB9482	VA-195	PCB8530	VO-71	PHB5516	VCA-1014	PLB3531A	VO-27	PA-190	VA-107
PAB9492	VA-176	PCB8712	VO-66	PHB5519	VCA-1063	PLB3569	VO-15	PA-191	VA-106
PAB9493	VA-196	PCB8765	VO-67	PHB5530	VCA-1068	PLB3593A	VO-106	PA-192	VA-103
PAB9501	VA-399	PCB8806	VO-73	PHB5571	VCA-1101	PLB3593B	VO-106	PA-193	VA-97
PAB9502	VA-361	PCB8902	VO-103	PHB5599	VCA-1170	PLB3600A	VO-118	PA-196	VFAP-917
PAB9525	VA-247	PCB9018	VO-76	PHB5637	VCA-1156	PLB3614	VO-25	PA-197	VA-104
PAB9555	VA-185	PCB9232	VO-137	PHB5644	VCA-1037	PLB3651	VO-95	PA-198	VFAP-7859
PAB9563	VA-322	PCB9301	VO-69	PHB5654	VCA-1043	PLB3675	VO-108	PA-199	VA-113
PAB9564	VA-183	PCB9447	VO-78	PHB5659	VCA-1089	PLB3682	VO-25	PA-200	VA-112
PAB9565	VA-328	PCB9461	VO-77	PHB5660	VCA-1051	PLB3766	VO-46	PA-201	VA-93
PAB9589	VA-177	PCB9498	VO-82	PHB5661	VCA-1035	PLB3786	VO-63	PA-202	VFAP-7857
PAB9600	VA-184	PCB9549	VO-81	PHB5662	VCA-1066	PLB3950	VO-19	PA-203	VA-111
PAB9600B	VA-184	PCB9641	VO-80	PHB5667	VCA-1031	PLB3976A	VO-64	PA-204	VA-320
PAB9603	VA-175	PCB9690	VO-94	PHB5674	VCA-1138	PLB3980	VO-55	PA-206	VA-94
PAB9662	VA-189	PCB9911	VO-85	PHB5675A	VCA-1139	PLB3985	VO-35	PA-207	VFAP-1643
PAB9669	VA-194	PCB9954	VO-85	PHB5675B	VCA-1139	PLB43	VO-95	PA-208	VA-260
PAB9681	VA-206	PCB9955	VO-128	PHB5676	VCA-1065	PLB4386	VO-40	PA-210	VFA-1641
PAB9683	VA-195	PCB9972	VO-84	PHB5685	VCA-1104	PLB4900	VO-88	PA-211	VA-99
PAB9687	VA-182	PCB9973	VO-111	PHB5764	VCA-1041	PLB4967	VO-40	PA-212	VA-120
PAB9762	VA-179	PCB9999	VO-90	PHB5772	VCA-1102	PLB5	VO-56	PA-214	VFAP-7908
PAB9778	VA-181	PFB10131	VG-2	PHB5836	VCA-1075	PLB5618	VO-86	PA-216	VA-125
PAB9798	VA-359	PFB33144	VG-14	PHB5840	VCA-1158	PLB6607	VO-106	PA-217	VA-91
PAB9806	VA-355	PFB54714	VG-33	PHB5850	VCA-1048	PLB6941	VO-135	PA-218	VFAP-1612
PAB9838	VA-180	PFB63169	VG-16	PHB5853	VCA-1109	PLB7317	VO-106	PA-219	VA-135
PAB9875	VA-211	PFB64702	VG-30	PHB5856	VCA-1050	PLB7328	VO-95	PA-220	VFAP-7859
PAB9895	VA-186	PFB64711	VG-32	PHB5857	VCA-1036	PLB8A	VO-1	PA-221	VA-338
PAB9898	VA-207	PHBT010	VCA-1048	PHB5858	VCA-1064	PLB8212	VO-60	PA-223	VA-387
PAB9902	VA-188	PHBT009	VCA-1159	PHB5859	VCA-1068	PLB8316	VO-118	PA-224	VFAP-1613
PAB9912	VA-330	PHBT010	VCA-1048	PHB5860	VCA-1155	PLB8873	VO-65	PA-226	VA-412
PAB9944	VA-197	PHBT016	VCA-1054	PHB5862	VCA-1053	PLB8994	VO-93	PA-227	VA-129
PAB9948	VA-269	PHBT017	VCA-1035	PHB5863	VCA-1110	PLB9100	VO-75	PA-228	VFAP-7893
PAB9969	VA-203	PHBT019	VCA-1047	PHB5864	VCA-1034	PLB9897	VO-52	PA-232	VA-132
PAB9997	VA-198	PHBT021	VCA-1039	PHB5865	VCA-1047	PLG3786	VO-63	PA-233	VA-117
PCBT001	VO-80	PHBT028	VCA-1053	PHB5868	VCA-1159	PLG3976A	VO-64	PA-235	VA-118
PCBT002	VO-78	PHBT029	VCA-1050	PHB5870	VCA-1044	PERFORMAX		PA-236	VA-116
PCBT003	VO-128	PHBT6030	VCA-1057	PHB5871	VCA-1038	PA-108	VA-38	PA-237	VA-259
PCBT004	VO-137	PHBT6031	VCA-1144	PHB5872	VCA-1145	PA-109	VA-44	PA-238	VA-124
PCBT005	VO-85	PHBT6032	VCA-1062	PHB5873	VCA-1046	PA-11	VA-2	PA-240	VA-138
PCBT006	VO-85	PHBT6033	VCA-1061	PHB5876	VCA-1049	PA-117	VA-69	PA-241	VA-137
PCBT007	VO-84	PHBT6035	VCA-1069	PHB5898	VCA-1146	PA-120	VA-45	PA-242	VA-140
PCBT008	VO-87	PHBT6037	VCA-1093	PHB6079	VCA-1055	PA-123	VA-40	PA-243	VA-78
PCBT009	LC-8170	PHBT6044	VCA-1114	PHB6089	VCA-1117	PA-130	VA-411	PA-244	VA-149
PCBT010	VO-150	PHB4860	VCA-1157	PHB8188	VCA-1042	PA-137	VA-403	PA-245	VA-410
PCBT011	VO-90	PHB5082	VCA-1001	PHB8222	VCA-1067	PA-138	VA-66	PA-246	VA-131
PCBT016	VO-98	PHB5245	VCA-1002	PHPT002	VCA-1096	PA-139	VA-205	PA-247	VA-136
PCBT017	VO-97	PHB5384	VCA-1017	PHPT024	VCA-1147	PA-142	VA-70	PA-248	VA-150
PCBT4018	VO-99	PHB5387	VCA-1163	PHP5383	VCA-1166	PA-145	VA-413	PA-249	VA-147
PCB10066	VO-111	PHB5388	VCA-1003	PHP5471	VCA-1164	PA-148	VA-85	PA-250	VA-146
PCB10075	VO-91	PHB5389	VCA-1008	PHP5477	VCA-1165	PA-15	VA-403	PA-251	VA-178
PCB10158	VO-87	PHB5390	VCA-1167	PHP5494	VCA-1168	PA-150	VA-90	PA-252	VA-157
PCB10160	VO-92	PHB5402	VCA-1122	PHP5498	VCA-1125	PA-153	VA-86	PA-253	VA-270
PCB10246	VO-98	PHB5413	VCA-1022	PHP5509	VCA-1127	PA-155	VA-269	PA-254	VA-152
PCB10295	VO-96	PHB5425	VCA-1060	PHP5526	VCA-1131	PA-161	VA-414	PA-255	VA-169
PCB10323	VO-129	PHB5426	VCA-1024	PHP5527	VCA-1074	PA-162	VA-78	PA-257	VA-154
PCB10358	VO-102	PHB5439	VCA-1012	PHP5527	VCA-1165	PA-163	VA-88	PA-258	VA-151
PCB10515	VO-99	PHB5448	VCA-1022	PHP5549	VCA-1133	PA-168	VA-84	PA-259	VA-165
PCB10855	VO-109	PHB5459	VCA-1013	PHP5677	VCA-2033	PA-169	VA-408	PA-26	VA-109
PCB10955	VO-110	PHB5477	VCA-1022	PHP6112	VCA-1068	PA-172	VA-83	PA-260	VA-167
PCB3970	VO-37	PHB5478	VCA-1020	PHP6154	VCA-1078	PA-175	VA-101	PA-261	VFAP-7865
PCB5320	LC-834	PHB5479	VCA-1014	PLB10060	VO-88	PA-177	VA-401	PA-262	VA-155
PCB6847	VO-70	PHB5480	VCA-1029	PLB10575	VO-88	PA-177	VA-96	PA-263	VA-163
PCB6848	VO-62	PHB5483	VCA-1161	PLB16	VO-95	PA-178	VA-416	PA-264	VA-156
PCB7073	LC-833	PHB5484	VCA-1123	PLB2	VO-88	PA-179	VA-102	PA-265	VA-142
PCB7732	VO-144	PHB5490	VCA-1030	PLB25	VO-108	PA-180	VFAP-7854	PA-266	VA-166
PCB8081	LC-8170	PHB5491	VCA-1028	PLB2870A	VO-15	PA-181	VFAP-7892	PA-267	VA-170
PCB8087	LC-8445	PHB5494	VCA-1168	PLB2951A	VO-40	PA-184	VA-98	PA-268	VA-162
PCB8158	VO-150	PHB5498	VCA-1125	PLB2957	VO-15	PA-186	VA-105	PA-269	VA-101
PCB8158A	VO-150	PHB5506	VCA-1160	PLB30	VO-65	PA-187	VA-89	PA-27	VA-110
PCB8213	VO-74	PHB5508	VCA-1040	PLB3387A	VO-16	PA-188	VA-114	PA-270	VA-144
PCB8278	VO-127	PHB5510	VCA-1162	PLB3429	VO-108	PA-189	VA-108	PA-271	VA-160

CAUTION: For general references only. Check catalog for correct filter application. Any use of this interchange to determine filter application is done at the installers risk.

PRECAUCION: Solamente para referencias generales. Revise el catálogo para la correcta aplicación del filtro. Cualquier uso de la referencia cruzada para determinar la aplicación del filtro es riesgo del instalador. ATTENTION : Seulement pour les références d'ordre général. Contrôler l'application correcte du filtre avec le catalogue. Toute utilisation de moyens afin de déterminer l'application d'un filtre est faite aux risques de l'installateur.

Cross Reference

Table da equivalencias da fabricantes

Code de renvoi au fabricant

MFR'S NUMBER	REPLACEMENT NUMBER	MFR'S NUMBER	REPLACEMENT NUMBER	MFR'S NUMBER	REPLACEMENT NUMBER	MFR'S NUMBER	REPLACEMENT NUMBER	MFR'S NUMBER	REPLACEMENT NUMBER
PERFORMAX		PA-482	VA-359	PA-566	VA-356	PC-115	VCA-1075	PC-85	VCA-1170
PA-272	VA-164	PA-483	VA-248	PA-567	VA-250	PC-116	VCA-1076	PC-86	VCA-1069
PA-28	VA-92	PA-484	VA-188	PA-568	VA-268	PC-117	VCA-1077	PC-87	VCA-1034
PA-302	VA-84	PA-485	VA-209	PA-569	VA-255	PC-119	VCA-1081	PC-88	VCA-1046
PA-326	VA-389	PA-486	VA-184	PA-570	VA-267	PC-120	VCA-1073	PC-89	VCA-1031
PA-332	VFAP-7912	PA-487	VA-198	PA-571	VA-265	PC-121	VCA-1078	PC-90	VCA-1038
PA-367	VA-158	PA-488	VA-208	PA-572	VA-274	PC-122	VCA-1082	PC-91	VCA-1049
PA-369	VA-370	PA-499	VA-217	PA-573	VA-272	PC-123	VCA-1175	PC-92	VCA-1050
PA-373	VA-261	PA-500	VA-244	PA-574	VA-271	PC-124	VCA-1173	PC-93	VCA-1051
PA-380	VA-395	PA-501	VA-233	PA-575	VA-246	PC-125	VCA-1171	PC-94	VCA-1039
PA-388	VA-128	PA-502	VA-249	PA-577	VA-275	PC-126	VCA-1176	PC-95	VCA-1039
PA-396	VFAP-7912	PA-503	VA-377	PA-578	VA-273	PC-127	VCA-1186	PC-96	VCA-1041
PA-406	VA-148	PA-504	VA-213	PA-579	VA-283	PC-15	VCA-1123	PC-96C	VCA-2033
PA-407	VA-153	PA-505	VA-229	PA-580	VA-280	PC-18	VCA-1017	PC-98	VCA-1044
PA-409	VA-341	PA-506	VA-201	PA-581	VA-287	PC-2	VCA-1157	PC-99	VCA-1104
PA-411	VA-347	PA-507	VA-212	PA-582	VA-284	PC-22	VCA-1139	PC-1	VO-1
PA-412	VA-397	PA-508	VA-231	PA-583	VA-285	PC-28	VCA-1161	PC-10	VO-108
PA-413	VA-339	PA-509	VA-210	PA-584	VA-288	PC-3	VCA-1001	PC-104	VO-95
PA-414	VA-159	PA-510	VA-251	PA-585	VA-286	PC-31	VCA-1003	PC-105	VO-46
PA-416	VA-350	PA-511	VA-224	PA-586	VA-254	PC-34	VCA-1008	PC-106	VO-19
PA-417	VA-394	PA-512	VA-340	PA-587	VA-290	PC-35	VCA-1022	PC-108	VO-106
PA-421	VA-259	PA-513	VA-228	PA-588	VA-291	PC-36	VCA-1029	PC-109	VO-106
PA-423	VA-132	PA-514	VA-227	PA-589	VA-253	PC-37	VCA-1163	PC-112	VO-108
PA-426	VA-114	PA-515	VA-222	PA-590	VA-292	PC-38	VCA-1020	PC-113	VO-56
PA-427	VA-190	PA-516	VA-218	PA-591	VA-293	PC-39C	VCA-1165	PC-117	VO-134
PA-428	VA-346	PA-517	VA-223	PA-592	VA-295	PC-40	VCA-1012	PC-12	VO-15
PA-429	VA-191	PA-518	VA-214	PA-593	VA-296	PC-41C	VCA-1164	PC-121	VO-95
PA-431	VA-342	PA-519	VA-232	PA-594	VA-297	PC-42	VCA-1043	PC-125	VO-86
PA-432	VA-270	PA-520	VA-243	PA-595	VA-298	PC-43C	VCA-1131	PC-126	VO-35
PA-433	VA-171	PA-521	VA-154	PA-596	VA-299	PC-44	VCA-1028	PC-127	VO-86
PA-434	VA-176	PA-522	VA-203	PA-597	VA-300	PC-45	VCA-1037	PC-136	LC-834
PA-436	VA-169	PA-523	VA-207	PA-598	VA-301	PC-46C	VCA-1162	PC-141	VO-143
PA-437	VA-399	PA-524	VA-382	PA-599	VA-303	PC-47	VCA-1030	PC-143	VO-135
PA-438	VA-345	PA-525	VA-230	PA-600	VA-304	PC-48	VCA-1014	PC-144	LC-833
PA-439	VA-193	PA-526	VA-238	PA-601	VA-305	PC-49	VCA-1168	PC-147	VO-144
PA-441	VA-361	PA-528	VA-239	PA-602	VA-306	PC-50	VCA-1129	PC-149	VO-74
PA-442	VA-196	PA-529	VA-211	PA-603	VA-308	PC-53	VCA-1066	PC-153	VO-78
PA-443	VA-192	PA-530	VA-318	PA-608	VA-307	PC-54	VCA-1013	PC-154	VO-77
PA-445	VA-185	PA-532	VA-252	PA-610	VA-309	PC-55C	VCA-1127	PC-156	VO-81
PA-446	VA-279	PA-533	VA-234	PA-611	VA-302	PC-56	VCA-1160	PC-157	VO-82
PA-447	VA-172	PA-534	VA-289	PA-612	VA-311	PC-57	VCA-1125	PC-158	VO-128
PA-448	VA-335	PA-535	VA-241	PA-613	VA-312	PC-58	VCA-1063	PC-159	VO-80
PA-450	VA-183	PA-536	VA-237	PA-614	VA-310	PC-6	VCA-1060	PC-160	LC-845
PA-451	VA-184	PA-537	VA-323	PA-615	VA-393	PC-60	VCA-1014	PC-161	VO-84
PA-452	VA-247	PA-538	VA-380	PA-618	VA-427	PC60	VCA-1014	PC-162	VO-85
PA-453	VA-175	PA-539	VA-226	PA-619	VA-326	PC-62	VCA-1067	PC-163	VO-91
PA-454	VA-177	PA-540	VA-221	PA-620	VA-313	PC-63	VCA-1024	PC-164	VO-90
PA-455	VFAP-7865	PA-541	VA-225	PA-621	VA-429	PC-64	VCA-1133	PC-165	VO-87
PA-456	VA-205	PA-542	VA-240	PA-622	VA-296	PC-65	VCA-1040	PC-166	VO-69
PA-457	VA-189	PA-543	VA-332	PA-623	VA-426	PC-67C	VCA-1040	PC-167	VO-88
PA-458	VA-195	PA-544	VA-353	PA-624	VA-314	PC67C	VCA-1040	PC-169	VO-96
PA-459	VA-206	PA-545	VA-220	PA-625	VA-317	PC-68	VCA-1056	PC-170	VO-81
PA-460	VA-194	PA-546	VA-242	PA-626	VA-428	PC68S	VCA-1056	PC-171	VO-98
PA-461	VA-333	PA-547	VA-336	PA-627	VA-334	PC-69	VCA-1054	PC-172	VO-102
PA-462	VA-182	PA-548	VA-235	PA-7	VA-321	PC-7	VCA-1167	PC-173	VO-88
PA-464	VA-355	PA-549	VA-219	PC-1	VCA-1002	PC-70	VCA-1070	PC-174	VO-99
PA-465	VA-174	PA-550	VA-236	PC-100	VCA-1048	PC-71	VCA-1122	PC-175	VO-101
PA-467	VA-328	PA-552	VA-266	PC-101	VCA-1096	PC-72	VCA-1042	PC-176	VO-103
PA-468	VA-179	PA-553	VA-258	PC-102	VCA-1047	PC-73	VCA-1022	PC-177	VO-104
PA-469	VA-181	PA-554	VA-337	PC-103	VCA-1146	PC-74C	VCA-1124	PC-178	VO-97
PA-471	VA-330	PA-555	VA-264	PC-104	VCA-1022	PC-76	VCA-2033	PC-179	VO-109
PA-472	VA-325	PA-556	VA-202	PC-105	VCA-1052	PC-77	VCA-1102	PC-18A	VO-27
PA-473	VA-186	PA-557	VA-263	PC-106	VCA-1053	PC-78	VCA-1068	PC-180	VO-110
PA-474	VA-197	PA-558	VA-202	PC-107	VCA-1054	PC-79	VCA-1065	PC-181	VO-85
PA-475	VA-180	PA-559	VA-343	PC-108	VCA-1055	PC-8	VCA-1026	PC-182	VO-106
PA-476	VA-269	PA-560	VA-278	PC-109	VCA-1057	PC-8C	VCA-1166	PC-183	VO-111
PA-477	VA-322	PA-561	VA-245	PC-110	VCA-1061	PC-80	VCA-1001	PC-184	VO-114
PA-478	VA-200	PA-562	VA-282	PC-111	VCA-1142	PC81	VCA-1135	PC-185	VO-117
PA-479	VA-215	PA-563	VA-257	PC-112	VCA-1071	PC-82	VCA-1035	PC-186	VO-116
PA-480	VA-216	PA-564	VA-362	PC-113	VCA-1118	PC-83	VCA-1031	PC-187	VO-151
PA-481	VA-202	PA-565	VA-294	PC-114	VCA-1059	PC-84	VCA-1089	PC-188	VO-123

CAUTION: For general references only. Check catalog for correct filter application. Any use of this interchange to determine filter application is done at the installers risk.
 PRECAUCION: Solamente para referencias generales. Revise el catálogo para la correcta aplicación del filtro. Cualquier uso de la referencia cruzada para determinar la aplicación del filtro es riesgo del instalador. ATTENTION : Seulement pour les références d'ordre général. Contrôler l'application correcte du filtre avec le catalogue. Toute utilisation de moyens afin de déterminer l'application d'un filtre est faite aux risques de l'installateur.

Cross Reference

Table da equivalencias da fabricantes

Code de renvoi au fabricant

MFR'S NUMBER	REPLACEMENT NUMBER	MFR'S NUMBER	REPLACEMENT NUMBER	MFR'S NUMBER	REPLACEMENT NUMBER	MFR'S NUMBER	REPLACEMENT NUMBER	MFR'S NUMBER	REPLACEMENT NUMBER
PERFORMAX		95811546600	VO-117	SA34479	VA-78	SL14459	VO-106	PA4632	VA-88
PO-189	VO-142	95811556200	VO-117	SA34715	VA-99	SL14460	VO-106	PA4633	VA-269
PO-19	VO-118	99610722552	VO-127	SA34717	VA-98	SL14476	VO-40	PA4645	VA-401
PO-190	VO-115	99610722553	VO-127	SA34721	VFAP-7859	SL14477	VO-40	PA4645	VA-96
PO-191	VO-92	99610722560	VO-127	SA34799	VA-103	SL14610	VO-106	PA4646	VA-158
PO-2	VO-108	POWER FLO		SA34852	VFAP-917	SL14612	VO-106	PA4648	VA-416
PO-21	VO-25	PH5309	VO-73	SA34877	VA-89	SL14619	VO-35	PA4650	VA-101
PO-22	VO-15	SA13192	VA-40	SA34878	VA-94	SL14620	VO-106	PA4669	VA-97
PO-26	VO-40	SA14650	VA-101	SA34879	VA-114	SL14622	VO-106	PA4675	VA-261
PO-27	VO-25	SA15604	VA-217	SA34883	VA-412	SL14670	VO-95	PA4680	VA-83
PO-28	VO-108	SA23465	VA-69	SA34886	VA-125	SL15309	VO-73	PA4688	VA-207
PO-29	VO-55	SA23592	VA-66	SA34995	VA-124	SL15313	VO-65	PA4690	VA-102
PO-3	VO-65	SA24278	VA-86	SA35150	VA-135	SL15315	VO-66	PA4690	VA-336
PO-30	VO-35	SA24342	VA-85	SA35155	VFAP-1643	SL15436	VO-76	PA4711	VA-340
PO-31	VO-37	SA24343	VA-205	SA35192	VA-260	SL15505	VO-80	PA4712	VFAP-7854
PO-33	VO-106	SA24372	VA-90	SA35207	VA-131	SL20033	VO-108	PA4715	VA-99
PO-34	VO-95	SA24378	VA-70	SA35219	VA-144	SL20049	VO-65	PA4716	VA-401
PO-35	VO-15	SA24468	VA-84	SA35227	VA-91	SL20064	VO-15	PA4717	VA-98
PO-37	VO-106	SA24601	VA-414	SA35244	VA-153	SL20081	VO-95	PA4720	VA-104
PO-38	VO-40	SA24633	VA-269	SA35258	VA-178	SL20123	VO-108	PA4721	VFAP-7859
PO-39	VO-40	SA24645	VA-96	SA35265	VA-116	SL20195	VO-118	PA4722	VFAP-7892
PO-41A	VO-60	SA24648	VA-416	SA35266	VA-147	SL20252	VO-15	PA4727	VA-105
PO-42	VO-88	SA24680	VA-83	SA35267	VA-138	SL22167	VO-95	PA4729	VA-379
PO-45	VO-56	SA24690	VA-102	SA35290	VA-114	SL22821	VO-40	PA4731	VA-108
PO-47	VO-64	SA24712	VFAP-7854	SA35305	VA-146	SL24011	VO-55	PA4799	VA-103
PO-48	VO-58	SA24720	VA-104	SA35323	VA-149	SL24457	VO-25	PA4807	VA-370
PO-49	VO-63	SA24722	VFAP-7892	SA35330	VA-78	SL24466	VO-15	PA4819	VA-107
PO-51	VO-118	SA24731	VA-108	SA35359	VA-151	SL24484	VO-60	PA4831	VFAP-7857
PO-52	VO-65	SA24819	VA-107	SA35370	VA-190	SL24651	VO-88	PA4832	VA-106
PO-53	VO-62	SA24831	VFAP-7857	SA35396	VA-154	SL25230	VO-118	PA4838	VA-132
PO-54	VO-70	SA24832	VA-106	SA35397	VA-165	SL25250	VO-150	PA4839	VA-387
PO-55	VO-67	SA24858	VFAP-1612	SA35403	VA-192	SL25274	VO-67	PA4852	VFAP-917
PO-56	VO-73	SA24873	VA-113	SA35414	VA-164	SL25288	VO-108	PA4855	VA-338
PO-57	VO-86	SA24880	VA-109	SA35420	VA-166	SL25545	VO-150	PA4858	VFAP-1612
PO-58	VO-76	SA24881	VA-110	SA35431	VA-176	SL25608	VO-84	PA4859	VFAP-1613
PO-59	VO-75	SA25042	VA-93	SA35432	VA-163	SL30001	VO-1	PA4862	VFAP-7912
PO-60	VO-69	SA25048	VA-112	SA35433	VA-161	SL30288	VO-46	PA4873	VA-113
PO-61	VO-150	SA25049	VFAP-7893	SA35434	VA-185	SL34631	VO-56	PA4877	VA-89
PO-62	VO-66	SA25089	VA-129	SA35462	VA-160	SL35399	VO-75	PA4878	VA-94
PO-63	LC-8170	SA25148	VFAP-7908	SA35489	VA-322	SL35610	VO-90	PA4879	VA-114
PO-64	VO-71	SA25248	VA-117	SA35517	VA-247	SL44872	VO-63	PA4880	VA-109
PO-65	VO-93	SA25249	VA-118	SA35528	VA-182	SL45335	VO-64	PA4881	VA-110
PO-7	VO-95	SA25257	VA-136	SA35553	VA-179	SL45515	VO-81	PA4883	VA-412
PO-8	VO-15	SA25301	VA-142	SA35556	VA-181	SL45526	VO-81	PA4886	VA-125
PO-9A	VO-16	SA25306	VA-137	SA35560	VA-180	PREMIUM GUARD		PA4995	VA-124
PZA-539	VA-226	SA25324	VA-140	SA35578	VA-195	AF1010M	VA-234	PA5042	VA-93
PORSCHCE		SA25353	VA-150	SA35603	VA-200	AF5517	VA-247	PA5043	VA-120
021115351	VO-95	SA25372	VA-156	SA40004	VA-321	C15506	VCA-1160	PA5047	VA-111
90110720301	VO-1	SA25373	VA-152	SA43195	VA-38	PAF9179	VA-465	PA5048	VA-112
901107203-01	VO-15	SA25395	VA-193	SA44632	VA-88	PA1413	VA-501	PA5049	VFAP-7893
90110720302	VO-1	SA25398	VA-170	SA44688	VA-207	PA2923	VA-411	PA5050	VA-128
901107203-02	VO-15	SA25405	VA-155	SA44727	VA-105	PA3181	VA-45	PA5089	VA-129
90110720303	VO-1	SA25418	VA-162	SA45090	VA-92	PA3192	VA-40	PA5090	VA-92
901107203-03	VO-15	SA25446	VA-167	SA45314	VA-259	PA3195	VA-38	PA5091	VA-320
90110720305	VO-1	SA25456	VA-196	SA45387	VA-172	PA3380	VA-44	PA5105	VFAP-7865
901107203-05	VO-15	SA25463	VA-171	SA45512	VA-177	PA3465	VA-69	PA5108	VFAP-7912
90110720309	VO-15	SA25499	VA-270	SA47039	VA-157	PA3558	VA-389	PA5148	VFAP-7908
93110770100	VO-15	SA25503	VA-183	SA50091	VA-2	PA3590	VA-65	PA5150	VA-135
93110770100	VO-15	SA25507	VA-184	SA50092	VA-403	PA3592	VA-66	PA5155	VFAP-1643
944107201-02	VO-135	SA25566	VA-197	SA45669	VA-97	PA3593	VA-413	PA5192	VA-260
944107201-03	VO-135	SA25582	VA-215	SA55378	VA-111	PA4	VA-321	PA5206	VA-148
944107201-05	VO-135	SA25585	VA-184	SA55400	VA-169	PA4278	VA-86	PA5207	VA-131
944107201-06	VO-135	SA25588	VA-188	SA63181	VA-45	PA4342	VA-85	PA5219	VA-144
94410720107	VO-135	SA25594	VA-269	SL10017	VO-95	PA4343	VA-205	PA5227	VA-91
94410720108	VO-135	SA25635	VA-229	SL10085	VO-37	PA4361	VA-408	PA5244	VA-153
94410720190	VO-135	SA26067	VFA-1641	SL10111	VO-16	PA4372	VA-90	PA5248	VA-117
95510756100	VO-150	SA30067	VA-402	SL10193	VO-19	PA4378	VA-70	PA5249	VA-118
95511013100	VA-204	SA33380	VA-44	SL10241	VO-25	PA4468	VA-84	PA5257	VA-136
95511013110	VA-204	SA33590	VA-65	SL10291	VO-27	PA4479	VA-78	PA5258	VA-178
95810722200	VO-92	SA33593	VA-413	SL12222	VO-88	PA4601	VA-414	PA5265	VA-116
95810722210	VO-133	SA34361	VA-408	SL14006	VO-58	PA4622	VA-274	PA5266	VA-147

CAUTION: For general references only. Check catalog for correct filter application. Any use of this interchange to determine filter application is done at the installers risk.

PRECAUCION: Solamente para referencias generales. Revise el catálogo para la correcta aplicación del filtro. Cualquier uso de la referencia cruzada para determinar la aplicación del filtro es riesgo del instalador. ATTENTION : Seulement pour les références d'ordre général. Contrôler l'application correcte du filtre avec le catalogue. Toute utilisation de moyens afin de déterminer l'application d'un filtre est faite aux risques de l'installateur.

Cross Reference

Table da equivalencias da fabricantes

Code de renvoi au fabricant

MFR'S NUMBER	REPLACEMENT NUMBER	MFR'S NUMBER	REPLACEMENT NUMBER	MFR'S NUMBER	REPLACEMENT NUMBER	MFR'S NUMBER	REPLACEMENT NUMBER	MFR'S NUMBER	REPLACEMENT NUMBER
PREMIUM GUARD		PA5535	VA-174	PA5780	VA-252	PA6151	VA-287	PA99097	VA-458
PA5272	VA-410	PA5538	VA-328	PA5781	VA-202	PA6152	VA-296	PA99111	VA-429
PA5278	VA-159	PA5539	VA-380	PA5783	VA-211	PA6153	VA-291	PA99111	VA-459
PA5279	VA-339	PA5540	VA-370	PA5785	VA-329	PA6163	VA-285	PA99113	VA-396
PA5290	VA-114	PA5546	VA-204	PA5786	VA-309	PA6164	VA-272	PA99115	VA-466
PA5291	VA-122	PA5553	VA-179	PA5787	VA-351	PA6165	VA-286	PA99116	VA-464
PA5301	VA-142	PA5554	VA-355	PA5788	VA-315	PA6166	VA-334	PA99117	VA-454
PA5304	VA-397	PA5555	VA-386	PA5789	VA-278	PA6167	VA-293	PA9912	VA-304
PA5305	VA-146	PA5556	VA-181	PA5792	VA-282	PA6168	VA-290	PA9913	VA-305
PA5306	VA-137	PA5557	VA-330	PA5793	VA-262	PA6169	VA-327	PA9914	VA-306
PA5314	VA-259	PA5560	VA-180	PA5794	VA-360	PA6171	VA-292	PA99148	VA-490
PA5315	VA-146	PA5566	VA-197	PA5796	VA-323	PA6172	VA-390	PA9915	VA-312
PA5323	VA-149	PA5567	VA-249	PA5798	VA-289	PA6183	VA-310	PA9916	VA-308
PA5324	VA-140	PA5568	VA-186	PA5799	VA-368	PA6184	VA-473	PA99178	VA-456
PA5330	VA-78	PA5569	VA-382	PA5800	VA-360	PA6197	VA-297	PA9918	VA-446
PA5352	VA-270	PA5578	VA-195	PA5801	VA-374	PA6199	VA-298	PA99194	VA-465
PA5353	VA-150	PA5582	VA-215	PA5802	VA-368	PA6200	VA-300	PA9920	VA-452
PA5359	VA-151	PA5583	VA-216	PA5804	VA-353	PA6201	VA-299	PA99207	VA-471
PA5363	VA-191	PA5584	VA-208	PA5811	VA-365	PA6202	VA-301	PA99209	VA-461
PA5370	VA-190	PA5585	VA-184	PA5813	VA-448	PA6271	VA-429	PA99212	VA-470
PA5372	VA-156	PA5587	VA-377	PA5814	VA-317	PA6272	VA-306	PA99213	VA-485
PA5373	VA-152	PA5588	VA-188	PA5816	VA-372	PA6273	VA-426	PA99215	VA-468
PA5375	VA-350	PA5589	VA-359	PA5819	VA-258	PA6274	VA-307	PA99220	VA-449
PA5378	VA-111	PA5591	VA-109	PA5820	VA-236	PA6275	VA-331	PA99222	VA-467
PA5380	VA-394	PA5592	VA-198	PA5822	VA-219	PA6276	VA-393	PA99228	VA-425
PA5381	VA-347	PA5594	VA-269	PA5823	VA-349	PA6277	VA-427	PA99230	VA-488
PA5387	VA-172	PA5595	VA-187	PA5824	VA-332	PA6279	VA-308	PA99239	VA-469
PA5393	VA-399	PA5596	VA-226	PA5825	VA-447	PA6280	VA-302	PA99254	VA-453
PA5394	VA-345	PA5601	VA-228	PA5826	VA-318	PA6281	VA-303	PA99265	VA-500
PA5395	VA-193	PA5602	VA-227	PA5828	VA-328	PA6282	VA-304	PA99267	VA-273
PA5396	VA-154	PA5603	VA-200	PA5833	VA-240	PA6283	VA-305	PA99294	VA-497
PA5396	VA-245	PA5604	VA-217	PA5841	VA-246	PA6297	VA-312	PA99314	VA-474
PA5397	VA-165	PA5616	VA-364	PA5880	VA-263	PA6306	VA-237	PA99365	VA-498
PA5398	VA-170	PA5620	VA-337	PA5883	VA-354	PA6308	VA-220	PA9949	VA-435
PA5400	VA-169	PA5625	VA-248	PA5890	VA-263	PA6309	VA-221	PA9950	VA-442
PA5403	VA-192	PA5626	VA-365	PA5891	VA-375	PA6310	VA-184	PA9962	VA-419
PA5405	VA-155	PA5633	VA-222	PA5900	VA-444	PA6312	VA-357	PA9964	VA-450
PA5414	VA-164	PA5634	VA-213	PA5907	VA-253	PA6313	VA-225	PA9969	VA-434
PA5418	VA-162	PA5635	VA-229	PA6052	VA-358	PA6314	VA-264	PC1033	VCA-1096
PA5420	VA-166	PA5638	VA-218	PA6054	VA-384	PA6318	VA-316	PC1040	VCA-1146
PA5421	VA-346	PA5642	VA-223	PA6055	VA-383	PA6319	VA-424	PC1042	VCA-1041
PA5431	VA-176	PA5645	VA-352	PA6056	VA-358	PA6320	VA-311	PC1043	VCA-1048
PA5432	VA-163	PA5647	VA-201	PA6061	VA-294	PA67	VA-402	PC1050	VCA-1069
PA5433	VA-161	PA5649	VA-214	PA6064	VA-204	PA7039	VA-157	PC4010	VCA-1145
PA5434	VA-185	PA5650	VA-209	PA6065	VA-388	PA7492	VA-314	PC4012	VCA-1171
PA5440	VA-333	PA5651	VA-202	PA6067	VFA-1641	PA7765	VA-341	PC4013	VCA-1075
PA5443	VA-400	PA5652	VA-343	PA6093	VA-313	PA8153	VA-457	PC4014	VCA-1076
PA5446	VA-167	PA5653	VA-212	PA6094	VA-268	PA8156	VA-430	PC4068	VCA-1118
PA5449	VA-279	PA5655	VA-231	PA6100	VA-366	PA8164	VA-428	PC4080	VCA-1071
PA5451	VA-361	PA5656	VA-210	PA6101	VA-385	PA8171	VA-425	PC4103	VCA-1175
PA5456	VA-196	PA5657	VA-242	PA6102	VA-280	PA8172	VA-440	PC4211C	VCA-1183
PA5457	VA-325	PA5669	VA-244	PA6103	VA-445	PA8219	VA-462	PC4302	VCA-1097
PA5461	VA-313	PA5670	VA-232	PA6104	VA-378	PA8220	VA-463	PC4313	VCA-1069
PA5462	VA-160	PA5671	VA-243	PA6105	VA-378	PA8225	VA-451	PC4479	VCA-1044
PA5463	VA-171	PA5672	VA-154	PA6109	VA-266	PA91	VA-2	PC4482	VCA-1046
PA5467	VA-363	PA5673	VA-230	PA6114	VA-257	PA92	VA-403	PC4524	VCA-1110
PA5468	VA-205	PA5694	VA-371	PA6116	VA-273	PA99001	VA-453	PC4579	VCA-1064
PA5485	VA-167	PA5696	VA-381	PA6118	VA-283	PA99005	VA-423	PC4600	VCA-1115
PA5488	VA-342	PA5697	VA-239	PA6119	VA-275	PA99006	VA-449	PC4682	VCA-1113
PA5489	VA-322	PA5698	VA-251	PA6120	VA-267	PA9902	VA-297	PC4684	VCA-1047
PA5497	VA-335	PA5699	VA-224	PA6121	VA-245	PA99032	VA-438	PC4725	VCA-1036
PA5499	VA-270	PA5700	VA-356	PA6124	VA-265	PA99050	VA-432	PC4753	VCA-1144
PA5503	VA-183	PA5701	VA-238	PA6130	VA-254	PA99051	VA-431	PC4756	VCA-1147
PA5507	VA-184	PA5703	VA-233	PA6131	VA-255	PA9906	VA-393	PC4761	VCA-1047
PA5512	VA-177	PA5704	VA-367	PA6139	VA-391	PA9907	VA-331	PC4854	VCA-1048
PA5513	VA-175	PA5706	VA-364	PA6140	VA-284	PA99071	VA-418	PC4855	VCA-1159
PA5517	VA-247	PA5707	VA-203	PA6143	VA-443	PA99072	VA-417	PC4860	VCA-1157
PA5521	VA-189	PA5716	VA-373	PA6144	VA-319	PA99078	VA-437	PC4863	VCA-1039
PA5525	VA-194	PA5775	VA-241	PA6145	VA-296	PA9908	VA-311	PC4879	VCA-1054
PA5528	VA-182	PA5778	VA-326	PA6146	VA-295	PA9909	VA-344	PC4902	VCA-1155
PA5534	VA-206	PA5779	VA-235	PA6149	VA-288	PA99095	VA-455	PC5082	VCA-1001

CAUTION: For general references only. Check catalog for correct filter application. Any use of this interchange to determine filter application is done at the installers risk.
 PRECAUCION: Solamente para referencias generales. Revise el catálogo para la correcta aplicación del filtro. Cualquier uso de la referencia cruzada para determinar la aplicación del filtro es riesgo del instalador. ATTENTION : Seulement pour les références d'ordre général. Contrôler l'application correcte du filtre avec le catalogue. Toute utilisation de moyens afin de déterminer l'application d'un filtre est faite aux risques de l'installateur.

Cross Reference

Table da equivalencias da fabricantes

Code de renvoi au fabricant

MFR'S NUMBER	REPLACEMENT NUMBER	MFR'S NUMBER	REPLACEMENT NUMBER	MFR'S NUMBER	REPLACEMENT NUMBER	MFR'S NUMBER	REPLACEMENT NUMBER	MFR'S NUMBER	REPLACEMENT NUMBER
PREMIUM GUARD		PC5863	VCA-1110	PG241	VO-25	PG5610	VO-90	PG6127EX	VO-109
PC5245	VCA-1002	PC5864	VCA-1034	PG2500	VO-88	PG5641	VO-120	PG6135EX	VO-110
PC5246	VCA-1021	PC5870	VCA-1044	PG252	VO-15	PG5646	VO-129	PG6288EX	VO-132
PC5383	VCA-1026	PC5871	VCA-1038	PG257	VO-15	PG5690	LC-834	PG6290EX	VO-141
PC5384	VCA-1017	PC5872	VCA-1145	PG2821A	VO-40	PG5692	VO-97	PG6293EX	VO-133
PC5387	VCA-1163	PC5875	VCA-1114	PG288	VO-46	PG5702	VO-96	PG8157EX	VO-142
PC5388	VCA-1003	PC5876	VCA-1049	PG291	VO-27	PG5830	VO-111	PG8176EX	VO-165
PC5389	VCA-1008	PC5877	VCA-1052	PG33	VO-108	PG5839	VO-98	PG9169EX	VO-168
PC5390	VCA-1167	PC6067	VCA-1062	PG381	VO-86	PG5843	VO-138	PG9904EX	VO-149
PC5402	VCA-1122	PC6079	VCA-1093	PG4006	VO-58	PG5848	VO-99	PG99064EX	VO-164
PC5413	VCA-1022K	PC6080	VCA-1061	PG4011	VO-55	PG5848A	VO-99	PG99098EX	VO-166
PC5425	VCA-1060	PC6089	VCA-1117	PG4457	VO-25	PG5895	VO-101	PG9925EX	VO-114
PC5426	VCA-1024	PC6090	VCA-1094	PG4459	VO-106	PG5904	VO-131	PG99256EX	VO-169
PC5439	VCA-1012	PC6098	VCA-1094	PG4460	VO-106	PG5909	VO-140	PG9983EX	VO-174
PC5448	VCA-1022	PC6099	VCA-1059	PG4466	VO-15	PG6127	VO-109	PRIMEGUARD	
PC5459	VCA-1013	PC6115	VCA-1055	PG4476	VO-40	PG6128	VO-104	F64702	VG-30
PC5473	VCA-1123	PC6127	VCA-1072	PG4477	VO-40	PG6135	VO-110	PAF10000	VA-344
PC5477	VCA-1165	PC6154C	VCA-1078C	PG4484	VO-60	PG6160	VO-121	PAF10058	VA-437
PC5478	VCA-1020	PC6156	VCA-1073	PG4610	VO-106	PG6161	VO-122	PAF10096	VA-434
PC5479	VCA-1014	PC6157	VCA-1072	PG4612	VO-106	PG6162	VO-116	PAF10257	VA-490
PC5480	VCA-1029	PC6174	VCA-1081	PG4615	VO-106	PG6288	VO-132	PAF10271	VA-418
PC5483	VCA-1161	PC6175	VCA-1177	PG4619	VO-35	PG6289	VO-151	PAF10337	VA-455
PC5484	VCA-1124	PC6176	VCA-1077	PG4620	VO-106	PG6291	VO-123	PAF10339	VA-456
PC5490	VCA-1030	PC6185	VCA-1120	PG4622	VO-106	PG6293	VO-133	PAF10394	VA-466
PC5491	VCA-1028	PC6203	VCA-1098	PG4631	VO-56	PG6296	VO-114	PAF10417	VA-464
PC5494	VCA-1168	PC6205C	VCA-1080	PG4651	VO-88	PG6311	VO-102	PAF10680	VA-470
PC5498	VCA-1125	PC6286	VCA-1174	PG4670	VO-95	PG64	VO-15	PAF1367	VA-488
PC5504	VCA-1126	PC8155	VCA-1186	PG4756	VO-70	PG7019	VO-95	PAF1378	VA-468
PC5506	VCA-1160	PC8188	VCA-1042	PG4757	VO-62	PG7530	VO-40	PAF3156	VA-453
PC5508	VCA-1040	PC8214	VCA-1185	PG4758	LC-833	PG7662	VO-52	PAF3162	VA-434
PC5509	VCA-1127	PC8222	VCA-1067	PG4798	VO-144	PG7819	VO-124	PAF3181	VA-45
PC5510	VCA-1162	PC9093	VCA-1093	PG4872	VO-63	PG81	VO-95	PAF3192	VA-40
PC5516	VCA-1014	PC9353	VCA-1050	PG4875	VO-95	PG8113	VO-77	PAF3195	VA-38
PC5518	VCA-1129	PC9359	VCA-1114	PG49	VO-65	PG8154	VO-115	PAF3260	VA-467
PC5519	VCA-1063	PC9374C	VCA-1127	PG5230	VO-118	PG85	VO-37	PAF3380	VA-44
PC5526	VCA-1131	PC9685	VCA-1146	PG5234	VO-85	PG8812	LC-834	PAF3465	VA-69
PC5527	VCA-1074	PC99052	VCA-1178	PG5247	LC-8170	PG99016	VO-167	PAF3590	VA-65
PC5530	VCA-1068	PC99076	VCA-1181	PG5250	VO-150	PG99139	VO-172	PAF3592	VA-66
PC5537	VCA-1056	PC99099	VCA-1188	PG5251	LC-8445	PG9934	VO-153	PAF3593	VA-413
PC5549	VCA-1133	PC99155	VCA-1190	PG5274	VO-67	PG9953	VO-170	PAF4	VA-321
PC5571	VCA-1101	PC99156	VCA-1179	PG5276	VO-69	PGF5277	VO-103	PAF4278	VA-86
PC5572	VCA-1102	PC99157	VCA-2043	PG5277	VO-103	UPG64R	VO-160	PAF4342	VA-85
PC5576	VCA-1134	PC99238C	VCA-1195	PG5280	VO-74	PREMIUM GUARD EXTENDED LIFE	PAF4343		VA-205
PC5586C	VCA-1135	PC99239	VCA-1191	PG5288	VO-108	PG111EX	VO-16	PAF4361	VA-408
PC5599	VCA-1170	PC99266	VCA-2055	PG5308	VO-71	PG4612EX	VO-106	PAF4372	VA-90
PC5621	VCA-1172	PC9928	VCA-1110	PG5309	VO-73	PG4651EX	VO-88	PAF4378	VA-70
PC5624C	VCA-1103	PC9932	VCA-1082	PG5313	VO-65	PG4670EX	VO-95	PAF4468	VA-84
PC5637	VCA-1156	PC99350	VCA-2035	PG5315	VO-66	PG5247EX	LC-8170	PAF4479	VA-78
PC5643	VCA-1070	PC99384	VCA-1178	PG5316	VO-127	PG5274EX	VO-67	PAF4601	VA-414
PC5644	VCA-1037	PC99415	VCA-1102	PG5317	VO-86	PG5277EX	VO-103	PAF4622	VA-274
PC5654	VCA-1043	PC9954	VCA-1193	PG5335	VO-64	PG5315EX	VO-66	PAF4629	VA-408
PC5659	VCA-1089	PC9958	VCA-1173	PG5399	VO-75	PG5436EX	VO-76	PAF4632	VA-88
PC5660	VCA-1051	PC9977	VCA-1176	PG5401	VO-93	PG5465EX	VO-82	PAF4633	VA-269
PC5661	VCA-1035	PC9978	VCA-1122	PG5436	VO-76	PG5505EX	VO-80	PAF4645	VA-96
PC5662	VCA-1066	PF131	VG-2	PG5465	VO-82	PG5511	VO-128	PAF4646	VA-158
PC5667	VCA-1031	PF3727	VG-14	PG5476	VO-78	PG5511EX	VO-128	PAF4648	VA-416
PC5668	VCA-1022K	PF3802	VG-16	PG5495	VO-161	PG5545EX	VO-150	PAF4650	VA-101
PC5674	VCA-1138	PF3850	VG-32	PG5505	VO-80	PG5564EX	VO-112	PAF4669	VA-97
PC5675	VCA-1139	PF4702	VG-30	PG5511	VO-128	PG5579EX	VO-94	PAF4675	VA-261
PC5675A	VCA-1139	PF4711	VG-32	PG5515	VO-81	PG5581EX	VO-85	PAF4680	VA-83
PC5676	VCA-1065	PF5455	VG-16	PG5526	VO-81	PG5598EX	VO-92	PAF4688	VA-207
PC5677	VCA-2033	PF7315	VG-33	PG5526FC	VO-81CAP	PG5607EX	VO-91	PAF4690	VA-102
PC5685	VCA-1104	PF7333	VG-30	PG5536	VO-103	PG5608EX	VO-84	PAF4690	VA-336
PC5764	VCA-1041	PG1A	VO-1	PG5545	VO-150	PG5609EX	VO-87	PAF4691	VFAP-1643
PC5770	VCA-1058	PG1010C	VO-96	PG5564	VO-112	PG5646EX	VO-129	PAF4711	VA-340
PC5836	VCA-1075	PG111	VO-16	PG5579	VO-94	PG5690EX	LC-834	PAF4712	VFAP-7854
PC5840	VCA-1158	PG123	VO-108	PG5581	VO-85	PG5830EX	VO-111	PAF4715	VA-99
PC5840C	VCA-1108	PG195	VO-118	PG5598	VO-92	PG5839EX	VO-98	PAF4717	VA-99
PC5844	VCA-1153	PG2167	VO-95	PG5607	VO-91	PG5843EX	VO-138	PAF4720	VA-104
PC5853	VCA-1109	PG2222	VO-88	PG5608	VO-84	PG5894EX	VO-139	PAF4721	VFAP-7859
PC5862	VCA-1053	PG2263U	VO-173	PG5609	VO-87	PG5895EX	VO-101	PAF4722	VFAP-7892

CAUTION: For general references only. Check catalog for correct filter application. Any use of this interchange to determine filter application is done at the installers risk.

PRECAUCION: Solamente para referencias generales. Revise el catálogo para la correcta aplicación del filtro. Cualquier uso de la referencia cruzada para determinar la aplicación del filtro es riesgo del instalador. ATTENTION : Seulement pour les références d'ordre général. Contrôler l'application correcte du filtre avec le catalogue. Toute utilisation de moyens afin de déterminer l'application d'un filtre est faite aux risques de l'installateur.

Cross Reference

Table da equivalencias da fabricantes

Code de renvoi au fabricant

MFR'S NUMBER	REPLACEMENT NUMBER	MFR'S NUMBER	REPLACEMENT NUMBER	MFR'S NUMBER	REPLACEMENT NUMBER	MFR'S NUMBER	REPLACEMENT NUMBER	MFR'S NUMBER	REPLACEMENT NUMBER
PRIMEGUARD		PAF5370	VA-190	PAF5601	VA-228	PAF5883	VA-354	PAF6314	VA-264
PAF4727	VA-105	PAF5372	VA-156	PAF5602	VA-227	PAF5891	VA-375	PAF6314HD	VA-264
PAF4729	VA-379	PAF5373	VA-152	PAF5603	VA-200	PAF5900	VA-444	PAF6318	VA-316
PAF4731	VA-108	PAF5375	VA-350	PAF5604	VA-217	PAF5907	VA-253	PAF6319	VA-424
PAF4799	VA-103	PAF5378	VA-111	PAF5620	VA-337	PAF6052	VA-250	PAF6320	VA-311
PAF4807	VA-370	PAF5387	VA-172	PAF5625	VA-248	PAF6054	VA-384	PAF67	VA-402
PAF4819	VA-107	PAF5393	VA-399	PAF5626	VA-365	PAF6055	VA-383	PAF7039	VA-157
PAF4831	VFAP-7857	PAF5394	VA-345	PAF5633	VA-222	PAF6056	VA-358	PAF7492	VA-314
PAF4832	VA-106	PAF5395	VA-193	PAF5634	VA-213	PAF6057	VA-229	PAF7765	VA-341
PAF4838	VA-132	PAF5396	VA-154	PAF5635	VA-229	PAF6061	VA-294	PAF8153	VA-457
PAF4839	VA-387	PAF5397	VA-165	PAF5638	VA-218	PAF6064	VA-202	PAF8164	VA-428
PAF4852	VFAP-917	PAF5398	VA-170	PAF5642	VA-223	PAF6065	VA-388	PAF8171	VA-425
PAF4855	VA-338	PAF5400	VA-169	PAF5645	VA-352	PAF6067	VFA-1641	PAF8172	VA-440
PAF4858	VFAP-1612	PAF5403	VA-192	PAF5647	VA-201	PAF6093	VA-313	PAF8219	VA-462
PAF4859	VFAP-1613	PAF5405	VA-155	PAF5649	VA-214	PAF6094	VA-268	PAF8220	VA-463
PAF4862	VFAP-7912	PAF5414	VA-164	PAF5650	VA-209	PAF6100	VA-366	PAF8225	VA-451
PAF4873	VA-113	PAF5418	VA-162	PAF5651	VA-202	PAF6101	VA-385	PAF91	VA-2
PAF4877	VA-89	PAF5420	VA-166	PAF5652	VA-343	PAF6102	VA-280	PCF10009	VCA-1082
PAF4878	VA-94	PAF5421	VA-346	PAF5653	VA-212	PAF6103	VA-445	PCF10142	VCA-1176
PAF4879	VA-114	PAF5431	VA-176	PAF5655	VA-231	PAF6104	VA-378	PCF10155	VCA-1181
PAF4880	VA-109	PAF5432	VA-163	PAF5656	VA-210	PAF6109	VA-266	PCF1381	VCA-1191
PAF4881	VA-110	PAF5433	VA-161	PAF5657	VA-242	PAF6114	VA-257	PCF23113	VCA-1173
PAF4883	VA-412	PAF5434	VA-185	PAF5669	VA-244	PAF6116	VA-273	PCF23117	VCA-1176
PAF4886	VA-125	PAF5436	VFAP-7912	PAF5670	VA-232	PAF6118	VA-283	PCF23119	VCA-1189
PAF49593	VA-446	PAF5440	VA-333	PAF5671	VA-243	PAF6119	VA-275	PCF23136	VCA-1185
PAF4995	VA-124	PAF5443	VA-400	PAF5672	VA-154	PAF6120	VA-267	PCF24012	VCA-1171
PAF5042	VA-93	PAF5446	VA-122	PAF5673	VA-230	PAF6121	VA-245	PCF24103	VCA-1175
PAF5043	VA-120	PAF5446	VA-167	PAF5694	VA-371	PAF6124	VA-265	PCF24211	VCA-1183
PAF5047	VA-111	PAF5449	VA-279	PAF5696	VA-381	PAF6130	VA-254	PCF4860	VCA-1157
PAF5048	VA-112	PAF5451	VA-361	PAF5697	VA-239	PAF6131	VA-255	PCF5082	VCA-1001
PAF5049	VFAP-7893	PAF5456	VA-196	PAF5698	VA-191	PAF6139	VA-391	PCF5245	VCA-1002
PAF5050	VA-128	PAF5457	VA-325	PAF5699	VA-224	PAF6140	VA-284	PCF5246	VCA-1021
PAF5089	VA-129	PAF5461	VA-199	PAF5700	VA-356	PAF6145	VA-296	PCF5383	VCA-1026
PAF5090	VA-92	PAF5462	VA-160	PAF5701	VA-238	PAF6146	VA-295	PCF5384	VCA-1017
PAF5091	VA-320	PAF5463	VA-171	PAF5703	VA-233	PAF6149	VA-288	PCF5387	VCA-1163
PAF5105	VFAP-7865	PAF5467	VA-363	PAF5704	VA-367	PAF6151	VA-287	PCF5388	VCA-1003
PAF5108	VFAP-7912	PAF5488	VA-342	PAF5707	VA-203	PAF6152	VA-296	PCF5389	VCA-1008
PAF5148	VFAP-7908	PAF5497	VA-335	PAF5716	VA-373	PAF6153	VA-291	PCF5390	VCA-1167
PAF5150	VA-135	PAF5499	VA-270	PAF5775	VA-241	PAF6163	VA-285	PCF5402	VCA-1122
PAF5155	VFAP-1643	PAF5503	VA-183	PAF5779	VA-235	PAF6165	VA-286	PCF5413	VCA-1165
PAF5192	VA-260	PAF5507	VA-184	PAF5780	VA-252	PAF6166	VA-334	PCF5425	VCA-1060
PAF5206	VA-148	PAF5512	VA-177	PAF5781	VA-202	PAF6167	VA-293	PCF5426	VCA-1024
PAF5207	VA-131	PAF5513	VA-175	PAF5783	VA-211	PAF6168	VA-290	PCF5439	VCA-1012
PAF5219	VA-144	PAF5517	VA-247	PAF5785	VA-329	PAF6169	VA-327	PCF5448	VCA-1022
PAF5227	VA-91	PAF5521	VA-189	PAF5786	VA-309	PAF6171	VA-292	PCF5459	VCA-1013
PAF5244	VA-153	PAF5525	VA-194	PAF5787	VA-351	PAF6172	VA-390	PCF5471	VCA-1164
PAF5248	VA-117	PAF5528	VA-182	PAF5788	VA-315	PAF6183	VA-310	PCF5473	VCA-1123
PAF5249	VA-118	PAF5534	VA-206	PAF5789	VA-278	PAF6184	VA-473	PCF5478	VCA-1020
PAF5257	VA-136	PAF5535	VA-174	PAF5789	VA-351	PAF6197	VA-297	PCF5479	VCA-1014
PAF5258	VA-178	PAF5538	VA-328	PAF5790	VA-282	PAF6199	VA-298	PCF5480	VCA-1029
PAF5265	VA-116	PAF5539	VA-380	PAF5792	VA-282	PAF6200	VA-300	PCF5483	VCA-1161
PAF5266	VA-147	PAF5546	VA-204	PAF5793	VA-362	PAF6201	VA-299	PCF5484	VCA-1124
PAF5267	VA-138	PAF5553	VA-179	PAF5794	VA-360	PAF6202	VA-301	PCF5490	VCA-1030
PAF5272	VA-410	PAF5554	VA-355	PAF5796	VA-323	PAF6271	VA-429	PCF5491	VCA-1028
PAF5278	VA-159	PAF5556	VA-181	PAF5798	VA-289	PAF6272	VA-306	PCF5494	VCA-1168
PAF5279	VA-339	PAF5560	VA-180	PAF5799	VA-234	PAF6273	VA-426	PCF5498	VCA-1125
PAF5290	VA-114	PAF5566	VA-197	PAF5801	VA-374	PAF6274	VA-307	PCF5506	VCA-1160
PAF5291	VA-122	PAF5567	VA-249	PAF5802	VA-377	PAF6276	VA-393	PCF5508	VCA-1040
PAF5301	VA-142	PAF5568	VA-186	PAF5804	VA-353	PAF6277	VA-427	PCF5510	VCA-1162
PAF5304	VA-397	PAF5569	VA-382	PAF5813	VA-448	PAF6279	VA-308	PCF5516	VCA-1014
PAF5305	VA-146	PAF5578	VA-195	PAF5814	VA-317	PAF6280	VA-302	PCF5518	VCA-1129
PAF5306	VA-137	PAF5582	VA-215	PAF5816	VA-372	PAF6281	VA-303	PCF5519	VCA-1063
PAF5314	VA-259	PAF5583	VA-216	PAF5819	VA-258	PAF6282	VA-304	PCF5527	VCA-1074
PAF5314HD	VA-271	PAF5584	VA-208	PAF5820	VA-236	PAF6283	VA-305	PCF5527	VCA-1169
PAF5323	VA-149	PAF5585	VA-269	PAF5822	VA-219	PAF6297	VA-312	PCF5530	VCA-1068
PAF5324	VA-140	PAF5587	VA-377	PAF5823	VA-349	PAF6306	VA-237	PCF5549	VCA-1133
PAF5330	VA-78	PAF5588	VA-188	PAF5824	VA-332	PAF6308	VA-220	PCF5571	VCA-1101
PAF5352	VA-270	PAF5589	VA-359	PAF5826	VA-318	PAF6309	VA-221	PCF5572	VCA-1102
PAF5353	VA-150	PAF5592	VA-198	PAF5833	VA-240	PAF6310	VA-184	PCF5586	VCA-1135
PAF5359	VA-151	PAF5594	VA-269	PAF5841	VA-246	PAF6312	VA-357	PCF5599	VCA-1170
PAF5363	VA-191	PAF5596	VA-226	PAF5880	VA-263	PAF6313	VA-225	PCF5621	VCA-1172

CAUTION: For general references only. Check catalog for correct filter application. Any use of this interchanging to determine filter application is done at the installers risk.
 PRECAUCION: Solamente para referencias generales. Revise el catálogo para la correcta aplicación del filtro. Cualquier uso de la referencia cruzada para determinar la aplicación del filtro es riesgo del instalador. ATTENTION : Seulement pour les références d'ordre général. Contrôler l'application correcte du filtre avec le catalogue. Toute utilisation de moyens afin de déterminer l'application d'un filtre est faite aux risques de l'installateur.

Cross Reference

Table da equivalencias da fabricantes

Code de renvoi au fabricant

MFR'S NUMBER	REPLACEMENT NUMBER	MFR'S NUMBER	REPLACEMENT NUMBER	MFR'S NUMBER	REPLACEMENT NUMBER	MFR'S NUMBER	REPLACEMENT NUMBER	MFR'S NUMBER	REPLACEMENT NUMBER
PRIMEGUARD		POF2500	VO-88	POF5839	VO-98	PLA34879	VA-114	PPL28812	LC-834
PCF5637	VCA-1156	POF252	VO-15	POF5843	VO-138	PLA34886	VA-125	PPL30001	VO-1
PCF5643	VCA-1024	POF257	VO-15	POF5848	VO-99	PLA35150	VA-135	PPL30040	VO-56
PCF5644	VCA-1037	POF2821A	VO-40	POF5895	VO-101	PLA35155	VFAP-1643	PPL30119	VO-1
PCF5654	VCA-1043	POF288	VO-46	POF5904	VO-131	PLA35192	VA-260	PPL30257	VO-15
PCF5659	VCA-1089	POF33	VO-108	POF5909	VO-140	PLA35227	VA-91	PPL30288	VO-46
PCF5660	VCA-1051	POF4006	VO-58	POF6127	VO-109	PLA35330	VA-78	PPL34631	VO-56
PCF5661	VCA-1035	POF4011	VO-55	POF6128	VO-104	PLA40004	VA-321	PPL34756	VO-70
PCF5662	VCA-1066	POF4457	VO-25	POF6135	VO-110	PLA43195	VA-38	PPL34875	VO-95
PCF5667	VCA-1031	POF4459	VO-106	POF6160	VO-121	PLA43558	VA-389	PPL35399	VO-75
PCF5668	VCA-1022	POF4460	VO-106	POF6161	VO-122	PLA44632	VA-88	PPL35610	VO-90
PCF5674	VCA-1138	POF4461	VO-106	POF6162	VO-116	PLA44727	VA-105	PPL44422	VO-64
PCF5675	VCA-1139	POF4466	VO-15	POF6288	VO-132	PLA45047	VA-111	PPL44757	VO-62
PCF5676	VCA-1065	POF4476	VO-40	POF6289	VO-105	PLA45090	VA-92	PPL44798	VO-144
PCF5677	VCA-2033	POF4477	VO-40	POF6291	VO-123	PLA45105	VFAP-7865	PPL44872	VO-63
PCF5685	VCA-1104	POF4484	VO-60	POF6293	VO-133	PLA45314	VA-259	PPL45335	VO-64
PCF5764	VCA-1041	POF4610	VO-106	POF6296	VO-114	PLA50091	VA-2	PPL45515	VO-81
PCF5834	VCA-1142	POF4612	VO-106	POF6311	VO-102	PLA50092	VA-403	PRO-TEC	
PCF5835	VCA-1103	POF4619	VO-35	POF7019	VO-95	PLA52923	VA-411	101	VO-1
PCF5836	VCA-1075	POF4631	VO-56	POF7819	VO-124	PLA54669	VA-97	101MP	VO-1
PCF5840	VCA-1158	POF4651	VO-88	POF8113	VO-77	PLA54855	VA-338	102	VO-65
PCF5851	VCA-1031	POF4670	VO-95	POF8154	VO-115	PLA63181	VA-45	102MP	VO-65
PCF5856	VCA-1050	POF4756	VO-70	POF8157	VO-142	PPL10017	VO-95	103	VO-108
PCF5860	VCA-1155	POF4757	VO-62	POF8161	VO-117	PPL10018	VO-95	104	VO-95
PCF5861	VCA-1144	POF4758	LC-833	POF85	VO-37	PPL10085	VO-37	104MP	VO-95
PCF5864	VCA-1034	POF4798	VO-144	POF8812	LC-834	PPL10111	VO-16	105	VO-108
PCF5865	VCA-1047	POF4872	VO-63	4612HK	VO-106	PPL10112	VO-16	106	VO-1
PCF5869	VCA-1069	POF49	VO-65	PRO-LINE		PPL10241	VO-25	107	VO-16
PCF5870	VCA-1044	POF5195	VO-95	CLA14680	VCA-1157	PPL10291	VO-27	107MP	VO-16
PCF5871	VCA-1038	POF5230	VO-118	CLA25082	VCA-1001	PPL12222	VO-88	115	VO-88
PCF5873	VCA-1046	POF5234	VO-85	PLA13192	VA-40	PPL14006	VO-88	116	VO-118
PCF5876	VCA-1049	POF5247	LC-8170	PLA14650	VA-101	PPL14459	VO-106	116MP	VO-118
PCF6073	VCA-1057	POF5250	VO-150	PLA23465	VA-69	PPL14459	VO-52	117	VO-90
PCF6080	VCA-1061	POF5251	LC-8445	PLA23592	VA-66	PPL14460	VO-106	120	VO-55
PCF6086	VCA-1115	POF5274	VO-67	PLA24278	VA-86	PPL14476	VO-40	120MP	VO-55
PCF6087	VCA-1116	POF5276	VO-69	PLA24342	VA-85	PPL14477	VO-40	125	VO-101
PCF6098	VCA-1094	POF5277	VO-103	PLA24343	VA-205	PPL14610	VO-106	130	VO-25
PCF6115	VCA-1055	POF5280	VO-74	PLA24372	VA-90	PPL14612	VO-106	130MP	VO-25
PCF6125C	VCA-1147	POF5288	VO-108	PLA24378	VA-70	PPL14619	VO-35	132	VO-56
PCF6126	VCA-1076	POF5308	VO-71	PLA24468	VA-84	PPL14620	VO-106	134	VO-95
PCF6154C	VCA-1078C	POF5309	VO-73	PLA24601	VA-414	PPL14622	VO-106	136	VO-15
PCF6155	VCA-1118	POF5313	VO-65	PLA24633	VA-269	PPL14670	VO-95	138	VO-52
PCF6156	VCA-1073	POF5315	VO-66	PLA24645	VA-96	PPL14758	LC-833	140	VO-19
PCF6157	VCA-1072	POF5316	VO-127	PLA24648	VA-416	PPL15313	VO-65	144	VO-27
PCF6158	VCA-1071	POF5317	VO-86	PLA24675	VA-261	PPL15436	VO-76	145	VO-87
PCF6174	VCA-1081	POF5335	VO-64	PLA24680	VA-83	PPL15505	VO-80	146	VO-84
PCF6175	VCA-1177	POF5399	VO-75	PLA24690	VA-102	PPL15839	VO-98	150	VO-25
PCF6176	VCA-1077	POF5401	VO-93	PLA24712	VFAP-7854	PPL16311	VO-102	151	VO-70
PCF6177	VCA-1097	POF5436	VO-76	PLA24716	VA-401	PPL20033	VO-108	152	VO-106
PCF6179	VCA-1075	POF5438	VO-119	PLA24720	VA-104	PPL20049	VO-65	152MP	VO-106
PCF6185	VCA-1120	POF5465	VO-82	PLA24722	VFAP-7892	PPL20064	VO-15	154	VO-40
PCF6286	VCA-1174	POF5476	VO-78	PLA24731	VA-108	PPL20081	VO-95	154MP	VO-40
PCF8155	VCA-1186	POF5495	VO-161	PLA24832	VA-106	PPL20123	VO-108	155	VO-82
PCF8188	VCA-1042	POF5505	VO-80	PLA24873	VA-113	PPL20173	VO-55	156	VO-35
PCF8222	VCA-1067	POF5511	VO-128	PLA24880	VA-109	PPL20195	VO-118	158	VO-95
PFF22A	VG-2	POF5515	VO-81	PLA24881	VA-110	PPL20252	VO-15	159	VO-88
PFF33144	VG-14	POF5526	VO-81	PLA25048	VA-112	PPL22167	VO-95	159MP	VO-88
PFF3727	VG-14	POF5536	VO-103	PLA25148	VFAP-7908	PPL22500	VO-88	160	VO-37
PFF3802	VG-16	POF5545	VO-150	PLA25248	VA-117	PPL22821	VO-40	161	VO-75
PFF3850	VG-32	POF5564	VO-112	PLA30067	VA-402	PPL24007	VO-108	162	VO-56
PFF54714	VG-33	POF5579	VO-94	PLA33380	VA-44	PPL24011	VO-55	162MP	VO-56
PFF64711	VG-32	POF5581	VO-85	PLA33590	VA-65	PPL24457	VO-25	163	VO-40
PFF7315	VG-33	POF5598	VO-92	PLA33593	VA-413	PPL24458	VO-106	164	VO-106
PFF7333	VG-30	POF5607	VO-91	PLA34361	VA-408	PPL24466	VO-15	164MP	VO-106
PFF8758	VG-16	POF5608	VO-84	PLA34479	VA-78	PPL24484	VO-60	165	VO-15
POF1A	VO-1	POF5609	VO-87	PLA34717	VA-98	PPL24651	VO-88	166	VO-108
POF111	VO-16	POF5610	VO-90	PLA34721	VFAP-7859	PPL25230	VO-118	166MP	VO-108
POF193	VO-19	POF5646	VO-129	PLA34799	VA-103	PPL25274	VO-67	167	VO-58
POF195	VO-118	POF5692	VO-97	PLA34852	VFAP-917	PPL25276	VO-69	167MP	VO-58
POF2222	VO-88	POF5702	VO-96	PLA34877	VA-89	PPL25288	VO-108	168	VO-106
POF241	VO-25	POF5830	VO-111	PLA34878	VA-94	PPL25608	VO-84	168MP	VO-106

CAUTION: For general references only. Check catalog for correct filter application. Any use of this interchange to determine filter application is done at the installers risk.

PRECAUCION: Solamente para referencias generales. Revise el catálogo para la correcta aplicación del filtro. Cualquier uso de la referencia cruzada para determinar la aplicación del filtro es riesgo del instalador. ATTENTION : Seulement pour les références d'ordre général. Contrôler l'application correcte du filtre avec le catalogue. Toute utilisation de moyens afin de déterminer l'application d'un filtre est faite aux risques de l'installateur.

Cross Reference

Table da equivalencias da fabricantes

Code de renvoi au fabricant

MFR'S NUMBER	REPLACEMENT NUMBER	MFR'S NUMBER	REPLACEMENT NUMBER	MFR'S NUMBER	REPLACEMENT NUMBER	MFR'S NUMBER	REPLACEMENT NUMBER	MFR'S NUMBER	REPLACEMENT NUMBER
PRO-TEC		324	VA-110	395	VA-159	479	VA-230	690	VA-241
169	VO-118	325	VA-107	396	VA-191	480	VA-265	691	VA-292
170	VO-95	326	VA-109	397	VA-166	481	VA-286	692	VA-287
170MP	VO-95	327	VA-106	398	VA-192	482	VA-219	693	VA-312
171	VO-64	328	VA-92	399	VA-270	483	VA-337	694	VA-296
172	VO-63	329	VA-94	400	VA-175	484	VA-318	695	VA-253
172MP	VO-63	330	VA-114	401	VA-176	485	VA-194	696	VA-316
173	VO-46	331	VA-101	402	VA-179	486	VA-263	698	VA-299
174	VO-95	332	VA-404	405	VA-131	487	VA-210	699	VA-317
175	VO-65	333	VA-113	406	VFAP-1613	488	VA-355	700	VA-280
175MP	VO-65	334	VA-104	407	VA-120	489	VA-353	701	VA-283
176	VO-67	335	VA-260	408	VFA-1641	490	VA-250	702	VA-307
177	VO-66	336	VFAP-7892	409	VA-182	491	VA-314	703	VA-293
177MP	VO-66	337	VFAP-7908	410	VA-181	492	VA-242	704	VA-304
178	LC-8170	338	VFAP-1643	411	VA-185	493	VA-279	705	VA-326
179	VO-69	339	VA-259	414	VA-247	494	VA-343	706	VA-300
179MP	VO-69	340	VA-97	415	VA-146	495	VA-199	707	VA-302
181	VO-15	341	VA-91	416	VA-207	496	VA-278	708	VA-306
182	VO-76	342	VA-112	417	VA-180	503	VG-2	710	VO-114
182MP	VO-76	343	VA-125	418	VA-177	510	VG-16	711	VO-117
183	VO-106	344	VFAP-917	426	VA-411	510MP	VG-16	712	VO-106
183MP	VO-106	345	VA-89	427	VFAP-7859	514	VG-14	713	VO-106
184	VO-159	346	VA-117	428	VA-111	514MP	VG-14	714	VO-104
185	VO-86	347	VA-116	429	VA-412	515	VG-32	715	VO-92
186	VO-93	348	VA-149	430	VA-93	515MP	VG-32	716	VO-106
187	VO-73	349	VFAP-7859	431	VA-167	516	VG-33	717	VO-106
188	VO-25	350	VFAP-7857	432	VA-184	516MP	VG-33	718	VO-40
190	VO-80	351	VFAP-1612	433	VA-195	517	VG-30	719	VO-112
191	VO-71	352	VFAP-7912	434	VA-269	517MP	VG-30	720	VO-69
192	VO-60	353	VA-270	435	VA-197	601	VCA-1097	721	VO-116
193	VO-62	354	VA-196	436	VA-333	603	VCA-1173	722	VO-129
194	VO-150	355	VA-157	437	VA-202	604	VCA-1175	723	VO-149
195	LC-834	356	VA-164	438	VA-111	605	VCA-1078	724	VO-81
196	VO-74	357	VA-142	439	VA-324	606	VCA-1176	725	VO-127
198	VO-86	358	VA-137	440	VA-132	607	VCA-1177	726	VO-110
199	VO-78	359	VA-154	441	VA-186	608	VA-311	727	VO-91
201	VA-2	360	VA-138	442	VA-184	609	VA-426	728	VO-123
202	VA-403	361	VA-146	443	VA-212	610	VA-429	729	VO-99
205	VA-402	362	VA-162	444	VA-200	611	VA-434	731	VO-165
207	VA-45	363	VA-140	445	VA-251	613	VA-298	732	VO-109
210	VA-44	364	VA-193	446	VA-203	614	VA-188	733	VA-358
212	VA-38	365	VA-165	447	VA-209	615	VA-208	735	VA-447
231	VA-66	366	VA-160	448	VA-214	616	VA-325	736	VA-437
232	VA-205	367	VA-150	450	VA-233	618	VA-335	737	VA-417
233	VA-65	368	VA-161	451	VA-226	619	VA-206	738	VA-432
240	VA-321	369	VA-149	452	VA-235	620	VA-189	739	VA-438
244	VA-40	370	VA-149	453	VA-232	621	VA-198	740	VA-308
251	VA-413	371	VA-99	455	VA-261	622	VA-224	741	VA-424
252	VA-38	372	VA-129	456	VA-336	623	VA-227	742	VA-425
253	VA-85	373	VFAP-7893	457	VA-346	624	VA-390	743	VA-284
261	VA-69	374	VA-144	458	VA-205	626	VA-252	745	VA-453
263	VA-70	375	VA-153	459	VA-238	627	VA-213	746	VA-431
270	VA-90	376	VFAP-7865	460	VA-258	630	VA-229	747	VA-418
271	VA-269	377	VA-124	461	VA-274	634	VA-225	748	VA-428
273	VA-88	378	VA-135	462	VA-220	640	VA-221	750	VO-109
274	VA-86	379	VA-118	463	VA-248	644	VA-215	751	VA-430
278	VA-78	380	VA-178	464	VA-243	645	VA-222	763	VO-106
279	VA-84	381	VA-65	465	VA-240	646	VA-154	774	VO-98
281	VA-408	382	VA-169	466	VA-244	650	VA-234	778	VO-103
283	VA-102	383	VA-163	467	VA-257	653	VA-216	783	VO-77
285	VA-103	384	VA-155	468	VA-332	656	VA-228	786	VO-85
286	VFAP-7854	385	VA-156	469	VA-265	664	VA-217	787	VO-85
287	VA-83	386	VA-183	470	VA-255	666	VA-289	788	VCA-1120
289	VA-98	387	VA-171	471	VA-275	669	VA-201	789	VCA-1061
290	VA-416	388	VA-147	472	VA-273	683	VA-223	790	VO-132
292	VA-34	389	VA-172	473	VA-202	684	VA-231	791	VCA-1051
299	VA-96	390	VA-190	474	VA-246	685	VA-291	792	VCA-1102
304	VG-2	391	VA-151	475	VA-273	686	VA-198	793	VCA-1181
311	VA-414	392	VA-170	476	VA-296	687	VA-290	795	VCA-1179
320	VA-108	393	VA-338	477	VA-237	688	VA-245	796	VCA-1184
323	VA-105	394	VA-136	478	VA-268	689	VA-288	797	VCA-1186

CAUTION: For general references only. Check catalog for correct filter application. Any use of this interchange to determine filter application is done at the installers risk.
 PRECAUCION: Solamente para referencias generales. Revise el catálogo para la correcta aplicación del filtro. Cualquier uso de la referencia cruzada para determinar la aplicación del filtro es riesgo del instalador. ATTENTION : Seulement pour les références d'ordre général. Contrôler l'application correcte du filtre avec le catalogue. Toute utilisation de moyens afin de déterminer l'application d'un filtre est faite aux risques de l'installateur.

Cross Reference

Table da equivalencias da fabricantes

Code de renvoi au fabricant

MFR'S NUMBER	REPLACEMENT NUMBER	MFR'S NUMBER	REPLACEMENT NUMBER	MFR'S NUMBER	REPLACEMENT NUMBER	MFR'S NUMBER	REPLACEMENT NUMBER	MFR'S NUMBER	REPLACEMENT NUMBER
PRO-TEC		902	VA-239	PROMOTIVE		AF5148	VFAP-7908	AF5507	VA-184
798	VCA-1188	903	VA-341	AF103	VA-321	AF5150	VA-135	AF5512	VA-177
799	VO-88	904	VA-267	AF2923	VA-411	AF5155	VFAP-1643	AF5513	VA-175
800	VCA-1080	905	VA-254	AF3181	VA-45	AF5192	VA-260	AF5517	VA-247
801	VCA-1081	906	VA-373	AF3192	VA-40	AF5206	VA-148	AF5521	VA-189
802	VCA-1153	907	VA-285	AF3195	VA-38	AF5207	VA-131	AF5525	VA-194
803	VCA-1037	908	VA-284	AF3380	VA-44	AF5219	VA-144	AF5528	VA-182
804	VCA-1082	910	VA-315	AF3465	VA-69	AF5227	VA-91	AF5534	VA-206
805	VCA-1071	911	VA-309	AF3590	VA-65	AF5244	VA-153	AF5535	VA-174
806	VO-97	912	VA-354	AF3592	VA-66	AF5248	VA-117	AF5538	VA-328
807	VCA-1077	913	VA-283	AF3593	VA-413	AF5249	VA-118	AF5539	VA-380
808	VCA-1094	914	VA-294	AF4	VA-321	AF5257	VA-136	AF5553	VA-179
809	VCA-1115	915	VA-249	AF4278	VA-86	AF5258	VA-178	AF5556	VA-181
810	VCA-1076	916	VA-448	AF4342	VA-85	AF5265	VA-116	AF5557	VA-330
811	VCA-1174	917	VA-357	AF4343	VA-205	AF5266	VA-147	AF5560	VA-180
812	VO-111	918	VA-236	AF4361	VA-408	AF5267	VA-190	AF5566	VA-197
814	VCA-1166	919	VA-374	AF4372	VA-90	AF5272	VA-410	AF5567	VA-249
815	VCA-1031	920	VA-328	AF4378	VA-70	AF5278	VA-159	AF5568	VA-186
816	VCA-1035	921	VA-313	AF4468	VA-84	AF5279	VA-339	AF5578	VA-195
817	VCA-1167	922	VA-368	AF4479	VA-78	AF5290	VA-114	AF5582	VA-215
818	VCA-1001	923	VA-282	AF4601	VA-14	AF5301	VA-142	AF5583	VA-216
819	VCA-1002	924	VA-204	AF4632	VA-88	AF5304	VA-397	AF5584	VA-208
820	VCA-1003	930	VCA-1129	AF4633	VA-269	AF5305	VA-146	AF5585	VA-184
821	VCA-1008	931	VCA-1124	AF4645	VA-96	AF5306	VA-137	AF5587	VA-377
822	VCA-1022	933	VCA-1146	AF4646	VA-158	AF5314	VA-271	AF5588	VA-188
823	VCA-1074	934	VCA-1133	AF4648	VA-416	AF5323	VA-149	AF5589	VA-359
824	VCA-1063	935	VCA-1138	AF4650	VA-101	AF5324	VA-140	AF5592	VA-198
825	VCA-1020	936	VCA-1068	AF4669	VA-97	AF5330	VA-78	AF5594	VA-269
826	VCA-1012	937	VCA-1070	AF4675	VA-261	AF5352	VA-270	AF5596	VA-226
827	VCA-1068	938	VCA-1050	AF4680	VA-83	AF5353	VA-150	AF5601	VA-228
828	VCA-1010	939	VCA-1139	AF4688	VA-207	AF5359	VA-151	AF5602	VA-227
829	VCA-1037	940	VCA-1072	AF4690	VA-102	AF5363	VA-191	AF5603	VA-200
830	VCA-1030	941	VCA-1126	AF4711	VA-340	AF5370	VA-190	AF5604	VA-217
831	VCA-1028	943	VCA-1127	AF4712	VFAP-7854	AF5372	VA-156	AF5625	VA-248
832	VCA-1014	944	VCA-1157	AF4715	VA-99	AF5373	VA-152	AF5626	VA-365
833	VCA-1017	945	VCA-1021	AF4716	VA-401	AF5375	VA-350	AF5633	VA-222
834	VCA-1065	946	VCA-1116	AF4717	VA-98	AF5378	VA-111	AF5634	VA-213
835	VCA-1014	947	VCA-1160	AF4720	VA-104	AF5381	VA-347	AF5635	VA-229
836	VCA-1013	948	VCA-1043	AF4721	VFAP-7859	AF5387	VA-172	AF5638	VA-218
837	VCA-1042	955	VCA-1089	AF4722	VFAP-7892	AF5394	VA-345	AF5642	VA-223
838	VCA-1067	956	VCA-1122	AF4727	VA-105	AF5395	VA-193	AF5647	VA-201
839	VCA-1170	958	VCA-1113	AF4731	VA-108	AF5396	VA-154	AF5649	VA-214
840	VCA-2033	959	VCA-1052	AF4799	VA-103	AF5397	VA-165	AF5650	VA-209
841	VCA-1031	960	VCA-1147	AF4807	VA-370	AF5398	VA-170	AF5651	VA-202
842	VCA-1069	961	VCA-1161	AF4819	VA-107	AF5400	VA-169	AF5652	VA-343
843	VCA-1038	963	VCA-1096	AF4831	VFAP-7857	AF5403	VA-192	AF5653	VA-212
844	VCA-1135	963	VCA-1096	AF4832	VA-106	AF5405	VA-155	AF5655	VA-231
845	VCA-1044	967	VCA-1064	AF4838	VA-132	AF5414	VA-164	AF5656	VA-210
846	VCA-1036	969	VCA-1029	AF4852	VFAP-917	AF5418	VA-162	AF5657	VA-242
847	VCA-1047	971	VCA-1039	AF4855	VA-338	AF5420	VA-166	AF5669	VA-244
848	VCA-1038	972	VCA-1159	AF4858	VFAP-1612	AF5421	VA-346	AF5670	VA-232
849	VCA-1163	974	VCA-1040	AF4859	VFAP-1613	AF5431	VA-176	AF5671	VA-243
850	VCA-1049	975	VCA-1103	AF4862	VFAP-7912	AF5432	VA-163	AF5672	VA-154
851	VCA-1066	976	VCA-1158	AF4873	VA-113	AF5433	VA-161	AF5673	VA-230
852	VCA-1041	978	VCA-1171	AF4877	VA-89	AF5434	VA-185	AF5697	VA-239
853	VCA-1034	979	VCA-1061	AF4878	VA-94	AF5440	VA-333	AF5698	VA-251
854	VCA-1162	981	VCA-1093	AF4879	VA-114	AF5446	VA-167	AF5699	VA-224
855	VCA-1102	983	VCA-1165	AF4880	VA-109	AF5449	VA-279	AF5701	VA-238
856	VCA-1075	984	VCA-1125	AF4881	VA-110	AF5451	VA-361	AF5703	VA-233
857	VCA-1059	985	VCA-1118	AF4883	VA-412	AF5456	VA-196	AF5707	VA-203
858	VCA-1139	986	VCA-1078C	AF4886	VA-125	AF5457	VA-325	AF5775	VA-241
859	VCA-1048	987	VCA-1055	AF4995	VA-124	AF5461	VA-199	AF5779	VA-235
860	VCA-1051	989	VCA-1073	AF5042	VA-93	AF5462	VA-160	AF5780	VA-252
861	VCA-1046	990	VA-301	AF5043	VA-120	AF5463	VA-171	AF5781	VA-202
862	VCA-1075	991	VA-297	AF5048	VA-112	AF5467	VA-363	AF5783	VA-211
864	VA-323	992	VA-305	AF5049	VFAP-7893	AF5468	VA-205	AF5786	VA-309
868	VA-413	993	VA-303	AF5050	VA-128	AF5488	VA-342	AF5789	VA-278
869	VA-158	994	VCA-1062	AF5089	VA-129	AF5489	VA-322	AF5792	VA-282
879	VA-247	995	VCA-1053	AF5090	VA-92	AF5497	VA-335	AF5796	VA-323
884	VA-356	996	VO-142	AF5091	VA-320	AF5499	VA-270	AF5798	VA-289
894	VA-387			AF5105	VFAP-7865	AF5503	VA-183	AF5799	VA-234

CAUTION: For general references only. Check catalog for correct filter application. Any use of this interchange to determine filter application is done at the installers risk.

PRECAUCION: Solamente para referencias generales. Revise el catálogo para la correcta aplicación del filtro. Cualquier uso de la referencia cruzada para determinar la aplicación del filtro es riesgo del instalador. ATTENTION : Seulement pour les références d'ordre général. Contrôler l'application correcte du filtre avec le catalogue. Toute utilisation de moyens afin de déterminer l'application d'un filtre est faite aux risques de l'installateur.

Cross Reference

Table da equivalencias da fabricantes

Code de renvoi au fabricant

MFR'S NUMBER	REPLACEMENT NUMBER	MFR'S NUMBER	REPLACEMENT NUMBER	MFR'S NUMBER	REPLACEMENT NUMBER	MFR'S NUMBER	REPLACEMENT NUMBER	MFR'S NUMBER	REPLACEMENT NUMBER
PROMOTIVE		C36158P	VCA-1071	PH5526	VO-81	PA4711	VA-340	PA5330	VA-78
AF5801	VA-374	C45654P	VCA-1043	PH5536	VO-69	PA4712	VFAP-7854	PA5352	VA-270
AF5804	VA-353	C45871P	VCA-1038	PH5545	VO-150	PA4715	VA-99	PA5353	VA-150
AF5819	VA-258	F10131P	VG-2	PH5581	VO-85	PA4717	VA-98	PA5359	VA-151
AF5820	VA-236	F33144P	VG-14	PH5607	VO-91	PA4720	VA-104	PA5363	VA-191
AF5822	VA-219	F54714P	VG-33	PH5608	VO-84	PA4721	VFAP-7859	PA5370	VA-190
AF5824	VA-332	F64711P	VG-32	PH5609	VO-87	PA4722	VFAP-7892	PA5372	VA-156
AF5833	VA-240	G65702P	VG-30	PH5610	VO-90	PA4727	VA-105	PA5373	VA-152
AF5841	VA-246	PH1A	VO-1	PH5646	VO-129	PA4729	VA-379	PA5375	VA-350
AF5880	VA-263	PH111	VO-16	PH5692	VO-97	PA4731	VA-108	PA5378	VA-111
AF5907	VA-253	PH123	VO-108	PH5702	VO-96	PA4799	VA-103	PA5380	VA-394
AF6054	VA-384	PH17	VO-95	PH5839	VO-98	PA4807	VA-370	PA5381	VA-347
AF6061	VA-294	PH18	VO-95	PH5848	VO-99	PA4819	VA-107	PA5387	VA-172
AF6064	VA-202	PH193	VO-19	PH6127	VO-109	PA4831	VFAP-7857	PA5393	VA-399
AF6065	VA-388	PH195	VO-118	PH6128	VO-104	PA4832	VFAP-7857	PA5394	VA-345
AF6067	VFA-1641	PH2222	VO-88	PH6135	VO-110	PA4838	VA-132	PA5395	VA-193
AF6094	VA-268	PH2222BP	VO-88	PH6296	VO-114	PA4839	VA-387	PA5396	VA-245
AF6102	VA-280	PH241	VO-25	PH6311	VO-102	PA4852	VFAP-917	PA5397	VA-165
AF6109	VA-266	PH2500	VO-88	PH7662	VO-52	PA4855	VA-338	PA5398	VA-170
AF6114	VA-257	PH2500BP	VO-88	PH81	VO-95	PA4858	VFAP-1612	PA5400	VA-169
AF6116	VA-273	PH252	VO-15	PH8812	LC-834	PA4859	VFAP-1613	PA5403	VA-192
AF6118	VA-283	PH257	VO-15	PL85	VO-37	PA4862	VFAP-7912	PA5405	VA-155
AF6119	VA-275	PH2821A	VO-40	PRONTO		PA4873	VA-113	PA5410	VA-192
AF6120	VA-267	PH288	VO-46	PA160	VA-321	PA4877	VA-89	PA5414	VA-164
AF6121	VA-245	PH291	VO-27	PA192	VA-402	PA4878	VA-94	PA5418	VA-162
AF6124	VA-265	PH33	VO-108	PA3181	VA-45	PA4879	VA-114	PA5420	VA-166
AF6130	VA-254	PH373	VO-25	PA3192	VA-40	PA4880	VA-109	PA5421	VA-346
AF6131	VA-255	PH4006	VO-58	PA3195	VA-38	PA4881	VA-110	PA5431	VA-176
AF6140	VA-284	PH4007	VO-58	PA326	VA-2	PA4883	VA-412	PA5432	VA-163
AF6146	VA-295	PH4011	VO-55	PA327	VA-403	PA4886	VA-125	PA5433	VA-161
AF6149	VA-288	PH4457	VO-25	PA3380	VA-44	PA4939	VA-408	PA5434	VA-185
AF6151	VA-287	PH4459	VO-106	PA3441	VA-69	PA4995	VA-124	PA5440	VA-333
AF6153	VA-291	PH4460	VO-106	PA3465	VA-69	PA5042	VA-93	PA5443	VA-400
AF6165	VA-286	PH4466	VO-15	PA3492	VA-45	PA5043	VA-120	PA5446	VA-167
AF6168	VA-290	PH4476	VO-40	PA3559	VA-40	PA5047	VA-111	PA5449	VA-279
AF6171	VA-292	PH4477	VO-40	PA3588	VA-38	PA5048	VA-112	PA5451	VA-361
AF6306	VA-237	PH4484	VO-60	PA3590	VA-65	PA5049	VFAP-7893	PA5456	VA-196
AF6308	VA-220	PH4610	VO-106	PA3592	VA-66	PA5050	VA-128	PA5457	VA-325
AF6309	VA-221	PH4612	VO-106	PA3593	VA-413	PA5056	VA-205	PA5461	VA-199
AF6312	VA-357	PH4615	VO-106	PA3631	VA-48	PA5057	VA-413	PA5462	VA-160
AF6313	VA-225	PH4619	VO-35	PA3647	VA-44	PA5058	VA-66	PA5463	VA-171
AF6314	VA-264	PH4622	VO-106	PA3661	VA-48	PA5089	VA-129	PA5467	VA-363
AF67	VA-402	PH4631	VO-56	PA3828	VA-416	PA5090	VA-92	PA5468	VA-205
AF7039	VA-157	PH4651	VO-88	PA3901	VA-90	PA5091	VA-320	PA5488	VA-342
AF7492	VA-314	PH4670	VO-95	PA3902	VA-85	PA5105	VFAP-7865	PA5489	VA-322
AF91	VA-2	PH4757	VO-62	PA3914	VFAP-917	PA5108	VFAP-7912	PA5497	VA-335
AF92	VA-403	PH4798	VO-144	PA3916	VA-65	PA5125	VA-414	PA5499	VA-270
B3127	VA-34	PH4872	VO-63	PA4	VA-321	PA5148	VFAP-7908	PA5503	VA-183
B3128	VA-48	PH49	VO-65	PA4272	VFAP-7892	PA5150	VA-135	PA5507	VA-184
C15510P	VCA-1162	PH5230	VO-118	PA4278	VA-86	PA5155	VFAP-1643	PA5512	VA-177
C15873P	VCA-1046	PH5234	VO-85	PA4309	VA-86	PA5192	VA-260	PA5513	VA-175
C16112P	VCA-1096	PH5247	LC-8170	PA4342	VA-85	PA5207	VA-131	PA5517	VA-247
C25572P	VCA-1102	PH5250	VO-150	PA4343	VA-205	PA5219	VA-144	PA5521	VA-189
C25685P	VCA-1104	PH5274	VO-67	PA4361	VA-98	PA5227	VA-91	PA5525	VA-194
C25835P	VCA-1103	PH5276	VO-69	PA4372	VA-90	PA5244	VA-153	PA5528	VA-182
C25851P	VCA-1031	PH5280	VO-74	PA4378	VA-70	PA5248	VA-117	PA5534	VA-206
C25858P	VCA-1064	PH5288	VO-108	PA4468	VA-84	PA5249	VA-118	PA5535	VA-174
C25863P	VCA-1110	PH5308	VO-71	PA4479	VA-78	PA5257	VA-136	PA5538	VA-328
C25870P	VCA-1044	PH5309	VO-73	PA4601	VA-414	PA5258	VA-178	PA5539	VA-380
C25876P	VCA-1049	PH5313	VO-65	PA4622	VA-274	PA5265	VA-116	PA5540	VA-370
C26155P	VCA-1118	PH5315	VO-66	PA4632	VA-88	PA5266	VA-147	PA5553	VA-179
C35643P	VCA-1070	PH5317	VO-86	PA4633	VA-269	PA5278	VA-159	PA5554	VA-355
C35644P	VCA-1037	PH5335	VO-64	PA4645	VA-96	PA5290	VA-114	PA5555	VA-386
C35667P	VCA-1031	PH5399	VO-75	PA4646	VA-58	PA5291	VA-122	PA5556	VA-181
C35668P	VCA-1022	PH5401	VO-93	PA4648	VA-416	PA5301	VA-142	PA5557	VA-330
C35674P	VCA-1138	PH5436	VO-76	PA4650	VA-101	PA5304	VA-397	PA5560	VA-180
C35676P	VCA-1065	PH5465	VO-82	PA4669	VA-97	PA5305	VA-146	PA5566	VA-197
C35845P	VCA-1194	PH5476	VO-78	PA4675	VA-261	PA5306	VA-137	PA5567	VA-249
C35898P	VCA-1146	PH5505	VO-80	PA4680	VA-83	PA5314	VA-259	PA5568	VA-186
C36156P	VCA-1073	PH5511	VO-128	PA4688	VA-207	PA5323	VA-149	PA5569	VA-382
C36157P	VCA-1072	PH5515	VO-81	PA4690	VA-336	PA5324	VA-140	PA5578	VA-195

CAUTION: For general references only. Check catalog for correct filter application. Any use of this interchange to determine filter application is done at the installers risk.
 PRECAUCION: Solamente para referencias generales. Revise el catálogo para la correcta aplicación del filtro. Cualquier uso de la referencia cruzada para determinar la aplicación del filtro es riesgo del instalador. ATTENTION : Seulement pour les références d'ordre général. Contrôler l'application correcte du filtre avec le catalogue. Toute utilisation de moyens afin de déterminer l'application d'un filtre est faite aux risques de l'installateur.

Cross Reference

Table da equivalencias da fabricantes

Code de renvoi au fabricant

MFR'S NUMBER	REPLACEMENT NUMBER	MFR'S NUMBER	REPLACEMENT NUMBER	MFR'S NUMBER	REPLACEMENT NUMBER	MFR'S NUMBER	REPLACEMENT NUMBER	MFR'S NUMBER	REPLACEMENT NUMBER
PRONTO		PA6056	VA-358	PA8172	VA-440	PC5459	VCA-1013	PF3169	VG-16
PA5582	VA-215	PA6064	VA-202	PA8208	VA-153	PC5473	VCA-1123	PF4702	VG-30
PA5583	VA-216	PA6067	VFA-1641	PA8221	VA-91	PC5477	VCA-1165	PF4711	VG-32
PA5584	VA-208	PA6093	VA-313	PA8243	VA-260	PC5478	VCA-1020	PF4714	VG-33
PA5585	VA-184	PA6094	VA-268	PA8475	VA-118	PC5479	VCA-1014	PF5455	VG-16
PA5587	VA-377	PA6103	VA-445	PA8547	VA-136	PC5480	VCA-1029	PF6519	VG-30
PA5588	VA-188	PA6104	VA-378	PA8606	VA-116	PC5483	VCA-1161	PG22	VG-2
PA5589	VA-359	PA6114	VA-257	PA8754	VA-78	PC5484	VCA-1124	PG3727	VG-14
PA5592	VA-198	PA6116	VA-273	PA8756	VA-259	PC5490	VCA-1030	PG3802	VG-16
PA5594	VA-269	PA6118	VA-283	PA8805	VA-137	PC5491	VCA-1028	PO1A	VO-1
PA5595	VFAP-7893	PA6124	VA-265	PA8911	VA-165	PC5494	VCA-1168	PO111	VO-16
PA5596	VA-226	PA6139	VA-391	PA8925	VA-122	PC5498	VCA-1125	PO13	VO-56
PA5601	VA-228	PA6168	VA-290	PA8969	VA-140	PC5506	VCA-1160	PO16	VO-95
PA5602	VA-227	PA6200	VA-300	PA8997	VA-149	PC5508	VCA-1040	PO193	VO-19
PA5603	VA-200	PA6297	VA-312	PA9054	VA-154	PC5509	VCA-1127	PO195	VO-118
PA5604	VA-217	PA6306	VA-237	PA91	VA-2	PC5510	VCA-1162	PO2	VO-88
PA5620	VA-337	PA6308	VA-220	PA9113	VA-150	PC5516	VCA-1014	PO2222	VO-88
PA5625	VA-248	PA6309	VA-221	PA92	VA-403	PC5518	VCA-1129	PO241	VO-25
PA5626	VA-365	PA6310	VA-184	PA9269	VA-169	PC5519	VCA-1063	PO25	VO-108
PA5633	VA-222	PA6312	VA-357	PA9286	VA-151	PC5526	VCA-1131	PO2500	VO-88
PA5634	VA-213	PA6313	VA-225	PA9345	VA-161	PC5527	VCA-1074	PO252	VO-15
PA5635	VA-229	PA6314	VA-264	PA9360	VA-163	PC5530	VCA-1068	PO257	VO-15
PA5638	VA-218	PA6318	VA-316	PA9400	VA-167	PC5537	VCA-1056	PO2821A	VO-40
PA5642	VA-223	PA6366	VA-70	PA9401	VA-160	PC5549	VCA-1133	PO2825	VO-15
PA5645	VA-352	PA6395	VA-84	PA99001	VA-453	PC5572	VCA-1102	PO2844	VO-95
PA5647	VA-201	PA6479	VA-78	PA99006	VA-449	PC5576	VCA-1134	PO2849	VO-52
PA5649	VA-214	PA6555	VA-88	PA9902	VA-297	PC5586C	VCA-1135	PO2856A	VO-19
PA5650	VA-209	PA6626	VA-269	PA99071	VA-418	PC5621	VCA-1172	PO2870A	VO-15
PA5651	VA-202	PA6690	VA-96	PA99072	VA-417	PC5643	VCA-1070	PO288	VO-46
PA5652	VA-343	PA67	VA-402	PA99078	VA-437	PC5644	VCA-1037	PO291	VO-27
PA5653	VA-212	PA6807	VA-83	PA99095	VA-455	PC5654	VCA-1043	PO2951A	VO-40
PA5655	VA-231	PA6828	VA-416	PA99097	VA-458	PC5660	VCA-1051	PO30	VO-65
PA5656	VA-210	PA6850	VA-97	PA9912	VA-304	PC5661	VCA-1035	PO33	VO-108
PA5657	VA-242	PA7039	VA-157	PA9913	VA-305	PC5662	VCA-1066	PO3387A	VO-16
PA5669	VA-244	PA7094	VA-101	PA9918	VA-446	PC5667	VCA-1031	PO3429	VO-108
PA5670	VA-232	PA7164	VA-135	PA99194	VA-465	PC5668	VCA-1022K	PO3506	VO-58
PA5671	VA-243	PA7167	VA-98	PA99212	VA-470	PC5674	VCA-1138	PO3531	VO-27
PA5672	VA-154	PA7174	VA-103	PA9969	VA-434	PC5675	VCA-1139	PO3535	VO-55
PA5673	VA-230	PA7344	VA-104	PC1033	VCA-1096	PC5676	VCA-1065	PO3569	VO-15
PA5696	VA-381	PA7351	VA-102	PC1043	VCA-1048	PC5685	VCA-1104	PO3593	VO-106
PA5697	VA-239	PA7365	VFAP-7854	PC4012	VCA-1171	PC5764	VCA-1041	PO3593A	VO-106
PA5698	VA-251	PA7414	VA-107	PC4013	VCA-1075	PC5770	VCA-1058	PO3600	VO-118
PA5699	VA-224	PA7417	VFAP-7859	PC4068	VCA-1118	PC5840	VCA-1158	PO3614	VO-25
PA5700	VA-356	PA7420	VA-113	PC4302	VCA-1097	PC5840C	VCA-1108	PO3651A	VO-95
PA5701	VA-238	PA7421	VA-108	PC4313	VCA-1069	PC5853	VCA-1109	PO3664	VO-19
PA5703	VA-233	PA7426	VA-106	PC4479	VCA-1044	PC5863	VCA-1110	PO3675	VO-108
PA5706	VA-364	PA7431	VA-124	PC4482	VCA-1046	PC5864	VCA-1034	PO3682	VO-25
PA5775	VA-241	PA7432	VA-112	PC4684	VCA-1047	PC5875	VCA-1114	PO3766	VO-46
PA5779	VA-235	PA7438	VA-93	PC4756	VCA-1147	PC6067	VCA-1062	PO3786	VO-63
PA5785	VA-329	PA7440	VA-105	PC4761	VCA-1047	PC6080	VCA-1061	PO3807	VO-106
PA5786	VA-309	PA7492	VA-314	PC4854	VCA-1048	PC6087	VCA-1116	PO3970	VO-37
PA5787	VA-351	PA7597	VA-109	PC4855	VCA-1159	PC6089	VCA-1117	PO3976A	VO-64
PA5788	VA-315	PA7598	VA-110	PC4860	VCA-1157	PC6115	VCA-1055	PO3980	VO-55
PA5789	VA-278	PA7614	VA-120	PC4863	VCA-1039	PC6156	VCA-1073	PO3985	VO-55
PA5792	VA-282	PA7626	VA-125	PC4879	VCA-1054	PC6157	VCA-1072	PO4006	VO-58
PA5793	VA-362	PA7628	VFAP-7857	PC4902	VCA-1155	PC6174	VCA-1081	PO4011	VO-55
PA5798	VA-289	PA7640	VA-111	PC5082	VCA-1001	PC6175	VCA-1177	PO43	VO-95
PA5799	VA-234	PA7730	VA-89	PC5245	VCA-1002	PC6185	VCA-1120	PO4386	VO-40
PA5804	VA-353	PA7738	VFAP-1612	PC5246	VCA-1021	PC6286	VCA-1174	PO4457	VO-25
PA5811	VA-365	PA7765	VA-341	PC5383	VCA-1026	PC8155	VCA-1186	PO4459	VO-106
PA5816	VA-372	PA7774	VA-114	PC5384	VCA-1017	PC8188	VCA-1042	PO4460	VO-106
PA5819	VA-258	PA8038	VA-92	PC5387	VCA-1163	PC8222	VCA-1067	PO4466	VO-15
PA5822	VA-219	PA8039	VA-94	PC5388	VCA-1003	PC9353	VCA-1050	PO4476	VO-40
PA5824	VA-332	PA8040	VFAP-7908	PC5389	VCA-1008	PC99076	VCA-1181	PO4477	VO-40
PA5826	VA-318	PA8069	VA-144	PC5390	VCA-1167	PC99099	VCA-1188	PO4484	VO-60
PA5841	VA-246	PA8127	VA-412	PC5402	VCA-1122	PC99156	VCA-1179	PO4610	VO-106
PA5880	VA-263	PA8133	VA-117	PC5413	VCA-1022K	PC9932	VCA-1082	PO4612	VO-106
PA5891	VA-375	PA8141	VFA-1641	PC5425	VCA-1060	PC9954	VCA-1193	PO4615	VO-106
PA6052	VA-250	PA8142	VFAP-1643	PC5426	VCA-1024	PC9977	VCA-1176	PO4619	VO-35
PA6054	VA-384	PA8156	VA-430	PC5439	VCA-1012	PF131	VG-2	PO4631	VO-56
PA6055	VA-383	PA8162	VA-131	PC5448	VCA-1022	PF3144	VG-14	PO4651	VO-88

CAUTION: For general references only. Check catalog for correct filter application. Any use of this interchange to determine filter application is done at the installers risk.

PRECAUCION: Solamente para referencias generales. Revise el catálogo para la correcta aplicación del filtro. Cualquier uso de la referencia cruzada para determinar la aplicación del filtro es riesgo del instalador. ATTENTION : Seulement pour les références d'ordre général. Contrôler l'application correcte du filtre avec le catalogue. Toute utilisation de moyens afin de déterminer l'application d'un filtre est faite aux risques de l'installateur.

Cross Reference

Table da equivalencias da fabricantes

Code de renvoi au fabricant

MFR'S NUMBER	REPLACEMENT NUMBER	MFR'S NUMBER	REPLACEMENT NUMBER	MFR'S NUMBER	REPLACEMENT NUMBER	MFR'S NUMBER	REPLACEMENT NUMBER	MFR'S NUMBER	REPLACEMENT NUMBER
PRONTO		PO6311	VO-102	PG3802	VG-16	3711	VCA-1014	PA25446	VA-167
PO4670	VO-95	PO6552	VO-60	PG3802A	VG-16	3718	VCA-1034	PA25463	VA-171
PO4681	VO-15	PO6607	VO-106	PG3850	VG-32	3719	VCA-1058	PA25507	VA-184
PO4756	VO-70	PO7019	VO-95	PG7315	VG-33	3729	VCA-1053	PA25566	VA-197
PO4757	VO-62	PO7328	VO-95	PG7333	VG-30	3734	VCA-1124	PA30067	VA-402
PO4798	VO-144	PO7662	VO-52	3004	VCA-1157	3738	VCA-1158	PA33380	VA-44
PO484	VO-106	PO7819	VO-124	3006	VCA-1001	3740	VCA-1153	PA33590	VA-65
PO487	VO-108	PO8A	VO-1	3007	VCA-1017	3749	VCA-1093	PA34479	VA-78
PO4872	VO-63	PO8113	VO-77	3008	VCA-1021	3752	VCA-1061	PA34878	VA-94
PO49	VO-65	PO8157EX	VO-142	3010	VCA-1008	3780	VCA-1118	PA34879	VA-114
PO494	VO-25	PO8158	VO-150	3011	VCA-1002	3783	VCA-1075	PA34886	VA-125
PO4967	VO-40	PO8161	VO-117	3012	VCA-1003	3789	VCA-1188	PA35192	VA-260
PO5	VO-56	PO8316	VO-118	3013	VCA-1167	3793	VCA-1193	PA35227	VA-91
PO5230	VO-118	PO85	VO-37	3018	VCA-1122	3881	VCA-1073	PA35244	VA-153
PO5234	VO-85	PO8712	VO-66	3019	VCA-1060	3882	VCA-1026	PA35265	VA-116
PO5247	LC-8170	PO8765	VO-67	3021	VCA-1022K	3885	VCA-1162	PA35267	VA-138
PO5250	VO-150	PO8812	LC-834	3021A	VCA-1022	3886	VCA-1127	PA35323	VA-149
PO5251	LC-8445	PO8873	VO-65	3021AC	VCA-1022	3891	VCA-1106	PA35330	VA-78
PO5274	VO-67	PO9018	VO-76	3026	VCA-1013	3891C	VCA-1126	PA35396	VA-154
PO5276	VO-69	PO9100	VO-75	3027	VCA-1024	3893	VCA-1139	PA35414	VA-164
PO5277	VO-103	PO9904	VO-149	3030	VCA-1160	3898	VCA-1065	PA35431	VA-176
PO5280	VO-74	PO9925EX	VO-114	3032	VCA-1029	3899	VCA-1139	PA35432	VA-163
PO5288	VO-108	PO9953	VO-170	3033	VCA-1163	3900	VCA-1054	PA35433	VA-161
PO5308	VO-71	PO8812	LC-834	3036	VCA-1020	3912	VCA-1101	PA35462	VA-160
PO5309	VO-73	PRONTO EXTENDED LIFE		3037	VCA-1012	3913	VCA-1096	PA35528	VA-182
PO5313	VO-65	PO111EX	VO-16	3038	VCA-1168	3933	VCA-1175	PA35530	VA-206
PO5315	VO-66	PO195EX	VO-118	3039	VCA-1030	3956	VCA-1124	PA35560	VA-180
PO5316	VO-127	PO2222EX	VO-88	3040	VCA-1028	3961	VCA-1043	PA35592	VA-198
PO5317	VO-86	PO241EX	VO-25	3041	VCA-1014	3962	VCA-1014	PA35642	VA-223
PO5335	VO-64	PO2500EX	VO-88	3042	VCA-1129	3963	VCA-1040	PA35649	VA-214
PO5399	VO-75	PO4459EX	VO-106	3044	VCA-1164	3964	VCA-1067	PA40004	VA-321
PO5401	VO-93	PO4476EX	VO-40	3044C	VCA-1164	3965	VCA-1042	PA43195	VA-38
PO5436	VO-76	PO4612EX	VO-106	3045	VCA-1125	3967	VCA-1102	PA44727	VA-105
PO5465	VO-82	PO4651EX	VO-88	3046	VCA-1074	3968	VCA-1135	PA45090	VA-92
PO5476	VO-78	PO4670EX	VO-95	3047	VCA-1063	3968C	VCA-1135	PA45314	VA-259
PO5495	VO-161	PO5247EX	LC-8170	3052	VCA-1037	3969	VCA-1102	PA50091	VA-2
PO5505	VO-80	PO5274EX	VO-67	3055	VCA-1133	3970	VCA-1001	PL10017	VO-95
PO5511	VO-128	PO5277EX	VO-103	3056	VCA-1034	3971	VCA-1047	PL10111	VO-16
PO5515	VO-81	PO5288EX	VO-108	3058	VCA-1048	3973	VCA-1110	PL10193	VO-19
PO5526	VO-81	PO5315EX	VO-66	3059	VCA-1070	3977	VCA-1173	PL10241	VO-25
PO5536	VO-69	PO5436EX	VO-76	3062	VCA-1170	3978	VCA-1082	PL10291	VO-27
PO5545	VO-150	PO5465EX	VO-82	3063	VCA-1068	3979	VCA-1174	PL11403	VO-200
PO5564	VO-112	PO5505EX	VO-80	3064	VCA-2033	3985	VCA-1102	PL12222	VO-88
PO5579	VO-94	PO5511EX	VO-128	3650	VCA-1161	3991	VCA-1184	PL14006	VO-58
PO5581	VO-85	PO5545EX	VO-150	3658	VCA-1172	3992	VCA-1176	PL14459	VO-106
PO5598	VO-92	PO5579EX	VO-94	3663	VCA-1134	3993	VCA-1179	PL14460	VO-106
PO5607	VO-91	PO5581EX	VO-85	3666	VCA-1145	3995	VCA-1186	PL14476	VO-40
PO5608	VO-84	PO5598EX	VO-92	3667	VCA-1039	3996C	VCA-1189	PL14610	VO-106
PO5609	VO-87	PO5607EX	VO-91	3669	VCA-1089	3999	VCA-1181	PL14615	VO-106
PO5610	VO-90	PO5608EX	VO-84	3670	VCA-1066			PL14619	VO-35
PO5646	VO-129	PO5609EX	VO-87	3671	VCA-1113	PUREONE (PUROLATOR)		PL14620	VO-106
PO5690	VO-130	PO5610EX	VO-90	3672	VCA-1041	PA23465	VA-40	PL14622	VO-106
PO5692	VO-97	PO5646EX	VO-129	3673	VCA-1047	PA23592	VA-66	PL14670	VO-95
PO5702	VO-96	PO5690EX	LC-834	3675	VCA-1155	PA24278	VA-86	PL15309	VO-73
PO5830	VO-111	PO5830EX	VO-111	3679	VCA-1031	PA24343	VA-205	PL15313	VO-65
PO5839	VO-98	PO5839EX	VO-98	3682	VCA-1110	PA24372	VA-90	PL15317	VO-86
PO5843	VO-138	PO5894EX	VO-139	3684	VCA-1031	PA24378	VA-70	PL15436	VO-76
PO5848	VO-99	PO6135EX	VO-110	3685	VCA-1031	PA24645	VA-96	PL15505	VO-80
PO5848A	VO-99	PO6290EX	VO-141	3686	VCA-1031	PA24690	VA-102	PL15607	VO-91
PO5895	VO-101	PO6293EX	VO-133	3687	VCA-1046	PA24712	VFAP-7854	PL15839	VO-98
PO5904	VO-131	PO6296EX	VO-114	3690	VCA-1114	PA24720	VA-104	PL16311	VO-102
PO5909	VO-140	PO6311EX	VO-102	3693	VCA-1146	PA24722	VFAP-7892	PL20033	VO-108
PO6127	VO-109	PO9904EX	VO-149	3696	VCA-1044	PA24731	VA-108	PL20049	VO-65
PO6128	VO-104	PO99064EX	VO-164	3699	VCA-1138	PA24880	VA-109	PL20064	VO-15
PO6135	VO-110	PO99098EX	VO-166	3701	VCA-1035	PA24881	VA-110	PL20081	VO-95
PO6160	VO-121	PO9925EX	VO-114	3702	VCA-1104	PA25042	VA-93	PL20123	VO-108
PO6161	VO-122	PTC (POWER TRAIN COMPONENTS)		3703	VCA-1051	PA25048	VA-112	PL20195	VO-118
PO6162	VO-116			3704	VCA-1144	PA25248	VA-117	PL20252	VO-15
PO6288	VO-132	PBA3631	VA-48	3705	VCA-1070	PA25301	VA-142	PL22167	VO-95
PO6289	VO-151	PC22A	VG-2	3708	VCA-1147	PA25324	VA-140	PL22500	VO-88
PO6291	VO-123	PG3727	VG-14	3710	VCA-1103	PA25418	VA-162	PL22821	VO-40

CAUTION: For general references only. Check catalog for correct filter application. Any use of this interchange to determine filter application is done at the installers risk.
 PRECAUCION: Solamente para referencias generales. Revise el catálogo para la correcta aplicación del filtro. Cualquier uso de la referencia cruzada para determinar la aplicación del filtro es riesgo del instalador. ATTENTION : Seulement pour les références d'ordre général. Contrôler l'application correcte du filtre avec le catalogue. Toute utilisation de moyens afin de déterminer l'application d'un filtre est faite aux risques de l'installateur.

Cross Reference

Table da equivalencias da fabricantes

Code de renvoi au fabricant

MFR'S NUMBER	REPLACEMENT NUMBER	MFR'S NUMBER	REPLACEMENT NUMBER	MFR'S NUMBER	REPLACEMENT NUMBER	MFR'S NUMBER	REPLACEMENT NUMBER	MFR'S NUMBER	REPLACEMENT NUMBER
PUREONE (PUROLATOR)									
PL24011	VO-55	A4819	VA-107	A5396	VA-154	A5651	VA-202	A6130	VA-254
PL24457	VO-25	A4831	VFAP-7857	A5397	VA-165	A5652	VA-343	A6131	VA-255
PL24458	VO-106	A4832	VA-106	A5398	VA-170	A5653	VA-212	A6139	VA-391
PL24651	VO-88	A4838	VA-132	A5400	VA-169	A5655	VA-231	A6140	VA-284
PL25247	LC-8170	A4852	VFAP-917	A5403	VA-192	A5656	VA-210	A6144	VA-319
PL25274	VO-67	A4855	VA-338	A5405	VA-155	A5657	VA-242	A6145	VA-296
PL25276	VO-103	A4858	VFAP-1612	A5414	VA-164	A5669	VA-244	A6146	VA-295
PL25277	VO-103	A4859	VFAP-1613	A5418	VA-162	A5670	VA-232	A6149	VA-288
PL25288	VO-108	A4877	VA-113	A5420	VA-166	A5671	VA-243	A6151	VA-287
PL25401	VO-93	A4878	VA-89	A5421	VA-346	A5673	VA-230	A6153	VA-291
PL25608	VO-84	A4879	VA-94	A5431	VA-176	A5697	VA-239	A6163	VA-285
PL25609	VO-87	A4880	VA-114	A5432	VA-163	A5698	VA-251	A6165	VA-286
PL25848	VO-99	A4881	VA-109	A5433	VA-161	A5699	VA-224	A6166	VA-334
PL26127	VO-109	A4886	VA-110	A5434	VA-185	A5700	VA-356	A6167	VA-293
PL30001	VO-1	A4995	VA-125	A5440	VA-333	A5701	VA-238	A6168	VA-290
PL30288	VO-46	A5042	VA-124	A5446	VA-167	A5703	VA-233	A6171	VA-292
PL34631	VO-56	A5043	VA-93	A5449	VA-279	A5704	VA-367	A6172	VA-390
PL35399	VO-75	A5048	VA-120	A5451	VA-361	A5707	VA-203	A6183	VA-310
PL35581	VO-85	A5049	VA-112	A5456	VA-196	A5716	VA-373	A6197	VA-297
PL35610	VO-90	A5050	VFAP-7893	A5457	VA-325	A5775	VA-241	A6199	VA-298
PL36135	VO-110	A5089	VA-128	A5461	VA-199	A5778	VA-326	A6200	VA-300
PL36296	VO-114	A5090	VA-129	A5462	VA-160	A5779	VA-235	A6201	VA-299
PL38165	VO-149	A5090	VA-320	A5463	VA-171	A5780	VA-252	A6202	VA-301
PL41404	VO-169	A5105	VA-92	A5467	VA-363	A5783	VA-211	A6271	VA-429
PL44872	VO-63	A5108	VFAP-7865	A5488	VA-342	A5786	VA-309	A6272	VA-306
PL45335	VO-64	A5148	VFAP-7912	A5497	VA-335	A5787	VA-351	A6273	VA-426
PL45515	VO-81	A5150	VFAP-7908	A5503	VA-183	A5788	VA-315	A6274	VA-307
PL45526	VO-81	A5155	VA-135	A5507	VA-184	A5789	VA-278	A6275	VA-331
			VFAP-1643	A5512	VA-177	A5792	VA-282	A6276	VA-393
PUREPRO									
A3192	VA-40	A5192	VA-260	A5513	VA-175	A5793	VA-362	A6277	VA-427
A3195	VA-38	A5206	VA-322	A5517	VA-247	A5796	VA-323	A6279	VA-308
A3465	VA-69	A5207	VA-148	A5521	VA-189	A5798	VA-289	A6280	VA-302
A3590	VA-65	A5219	VA-131	A5525	VA-194	A5799	VA-234	A6281	VA-303
A3592	VA-66	A5227	VA-144	A5528	VA-182	A5801	VA-374	A6282	VA-304
A4	VA-321	A5244	VA-91	A5534	VA-206	A5802	VA-368	A6283	VA-305
A4278	VA-86	A5248	VA-153	A5535	VA-174	A5804	VA-353	A6297	VA-312
A4342	VA-85	A5249	VA-117	A5538	VA-328	A5814	VA-317	A6306	VA-237
A4343	VA-205	A5257	VA-118	A5546	VA-204	A5816	VA-372	A6308	VA-220
A4343	VA-205	A5258	VA-136	A5553	VA-179	A5819	VA-258	A6309	VA-221
A4361	VA-408	A5265	VA-178	A5556	VA-181	A5820	VA-236	A6312	VA-357
A4372	VA-90	A5266	VA-116	A5560	VA-180	A5822	VA-219	A6313	VA-215
A4378	VA-70	A5267	VA-147	A5566	VA-197	A5823	VA-349	A6314	VA-264
A4468	VA-84	A5272	VA-138	A5567	VA-249	A5824	VA-332	A6318	VA-316
A4479	VA-78	A5278	VA-410	A5568	VA-186	A5825	VA-447	A6319	VA-424
A4601	VA-414	A5279	VA-159	A5569	VA-382	A5826	VA-318	A6320	VA-311
A4622	VA-274	A5291	VA-339	A5578	VA-195	A5833	VA-240	A7039	VA-157
A4633	VA-269	A5301	VA-122	A5582	VA-215	A5841	VA-246	A7492	VA-314
A4645	VA-401	A5304	VA-142	A5583	VA-216	A5880	VA-263	A7765	VA-341
A4645	VA-96	A5305	VA-397	A5584	VA-208	A5883	VA-354	A8153	VA-457
A4646	VA-158	A5306	VA-146	A5587	VA-377	A5907	VA-253	A8156	VA-430
A4648	VA-416	A5314	VA-137	A5588	VA-188	A6052	VA-250	A8163	VA-428
A4650	VA-101	A5314	VA-259	A5589	VA-359	A6054	VA-384	A8168	VA-419
A4669	VA-97	A5314	VA-271	A5592	VA-198	A6055	VA-383	A8171	VA-425
A4675	VA-261	A5323	VA-324	A5595	VA-187	A6056	VA-358	A8172	VA-440
A4680	VA-83	A5324	VA-149	A5596	VA-226	A6061	VA-294	A8177	VA-438
A4688	VA-207	A5352	VA-140	A5601	VA-228	A6067	VFA-1641	A8189	VA-434
A4690	VA-102	A5353	VA-270	A5602	VA-227	A6093	VA-313	A8192	VA-446
A4711	VA-340	A5359	VA-150	A5603	VA-200	A6094	VA-268	A8193	VA-449
A4712	VA-404	A5363	VA-151	A5604	VA-217	A6100	VA-366	A8194	VA-432
A4712	VFAP-7854	A5370	VA-191	A5620	VA-337	A6101	VA-385	A8195	VA-417
A4715	VA-99	A5372	VA-190	A5625	VA-248	A6102	VA-280	A8197	VA-431
A4717	VA-98	A5373	VA-156	A5626	VA-365	A6103	VA-445	A8218	VA-442
A4720	VA-104	A5375	VA-152	A5633	VA-222	A6104	VA-378	A8219	VA-462
A4721	VFAP-7859	A5378	VA-350	A5634	VA-213	A6109	VA-266	A8220	VA-463
A4722	VFAP-7892	A5380	VA-111	A5635	VA-229	A6114	VA-257	A8223	VA-453
A4727	VA-105	A5381	VA-394	A5638	VA-218	A6116	VA-273	A8225	VA-451
A4729	VA-379	A5387	VA-347	A5642	VA-223	A6118	VA-283	A9058	VA-344
A4731	VA-108	A5393	VA-172	A5645	VA-352	A6119	VA-275	A9060	VA-450
A4799	VA-103	A5394	VA-399	A5647	VA-201	A6120	VA-267	A9061	VA-423
A4807	VA-370	A5395	VA-345	A5649	VA-214	A6121	VA-245	A9062	VA-396
			VA-193	A5650	VA-209	A6124	VA-265	A91	VA-2

CAUTION: For general references only. Check catalog for correct filter application. Any use of this interchange to determine filter application is done at the installers risk.

PRECAUCION: Solamente para referencias generales. Revise el catálogo para la correcta aplicación del filtro. Cualquier uso de la referencia cruzada para determinar la aplicación del filtro es riesgo del instalador. ATTENTION : Seulement pour les références d'ordre général. Contrôler l'application correcte du filtre avec le catalogue. Toute utilisation de moyens afin de déterminer l'application d'un filtre est faite aux risques de l'installateur.

Cross Reference

Table da equivalencias da fabricantes

Code de renvoi au fabricant

MFR'S NUMBER	REPLACEMENT NUMBER	MFR'S NUMBER	REPLACEMENT NUMBER	MFR'S NUMBER	REPLACEMENT NUMBER	MFR'S NUMBER	REPLACEMENT NUMBER	MFR'S NUMBER	REPLACEMENT NUMBER
PUREPRO		C25858	VCA-1064	C45662	VCA-1066	PL5274	VO-67	L2222S	VO-88
A9502	VA-471	C25863	VCA-1110	C45844	VCA-1153	PL5277	VO-103	L2222S	VO-88
A9503	VA-459	C25864	VCA-1034	C45871	VCA-1038	PL5277	VO-69	L241S	VO-25
A9506	VA-467	C25869	VCA-1069	C46126	VCA-1076	PL5280	VO-74	L241S	VO-95
A9508	VA-460	C25870	VCA-1044	C48162	VCA-1082	PL5308	VO-71	L241S	VO-95
A9509	VA-437	C25874	VCA-1113	F33144		PL5309	VO-73	L241S	VO-95
A9514	VA-418	C25876	VCA-1049	F54714		PL5315	VO-66	L2500S	VO-88
A9518	VA-455	C25877	VCA-1052	F64702		PL5316	VO-127	L2500S	VO-88
A9519	VA-466	C26073	VCA-1057	F64711		PL5436	VO-76	L4006S	VO-108
A9520	VA-458	C26086	VCA-1115	F65455		PL5438	VO-119	L4006S	VO-58
A9523	VA-464	C26087	VCA-1116	L111		PL5465	VO-82	L4459S	VO-106
A9524	VA-454	C26089	VCA-1117	L111		PL5476	VO-78	L4476S	VO-40
A9525	VA-465	C26155	VCA-1118	L165		PL5505	VO-80	L4612S	VO-106
A9526	VA-461	C26175	VCA-1177	L195		PL5511	VO-128	L4612S	VO-106
A9537	VA-392	C26176	VCA-1077	L195		PL5515	VO-81	L4612S	VO-106
A9538	VA-485	C26185	VCA-1120	L195		PL5515TC	VO-81CAP	L4612S	VO-19
A9539	VA-456	C26205C	VCA-1080	L195		PL5545	VO-150	L5288S	VO-108
A9540	VA-435	C28183	VCA-1171	L195		PL5564	VO-112	L5313S	VO-56
A9541	VA-490	C29064	VCA-1178	L2222		PL5579	VO-94	L5313S	VO-56
A9542	VA-336	C35402	VCA-1122	L2222		PL5593	VO-137	L5313S	VO-65
A9546	VA-469	C35426	VCA-1024	L2222		PL5598	VO-92	L5313S	VO-65
A9547	VA-468	C35448	VCA-1022	L2222		PL5607	VO-91	L5335S	VO-64
A9555	VA-470	C35448	VCA-1022K	L2222		PL5608	VO-84	L5399S	VO-75
A9558	VA-488	C35477	VCA-1165	L2222		PL5609	VO-87	L5895S	VO-101
A9562	VA-474	C35479	VCA-1014	L241		PL5610	VO-90	L6128S	VO-104
C14860	VCA-1157	C35484C	VCA-1124	L241		PL5641	VO-120	PURULATOR	
C15388	VCA-1003	C35491	VCA-1028	L241		PL5646	VO-129	A11479	VA-500
C15389	VCA-1008	C35494C	VCA-1168	L241		PL5690	VO-130	A13192	VA-40
C15390	VCA-1167	C35519	VCA-1063	L2878		PL5692	VO-97	A14622	VA-274
C15439	VCA-1012	C35530	VCA-1068	L288		PL5702	VO-96	A14650	VA-101
C15471C	VCA-1164	C35549C	VCA-1133	L4006		PL5830	VO-111	A15363	VA-191
C15510C	VCA-1162	C35586C	VCA-1135	L4006		PL5839	VO-98	A15604	VA-217
C15537C	VCA-1056	C35643	VCA-1070	L4006		PL5839UFI	VO-173	A15622	VA-274
C15599	VCA-1170	C35644	VCA-1037	L4457		PL5843	VO-138	A15669	VA-244
C15637	VCA-1156	C35660	VCA-1051	L4459		PL5848	VO-99	A15703	VA-233
C15659C	VCA-1089	C35661	VCA-1035	L4476		PL5894	VO-139	A15778	VA-326
C15850	VCA-1048	C35667	VCA-1031	L4484		PL5904	VO-131	A16065	VA-388
C15862	VCA-1053	C35674	VCA-1138	L4612		PL5909	VO-140	A16093	VA-313
C15873	VCA-1046	C35675	VCA-1139	L4612		PL6127	VO-109	A16094	VA-268
C16079	VCA-1093	C35676	VCA-1065	L4612		PL6135	VO-110	A16168	VA-290
C16098	VCA-1094	C35677C	VCA-2033	L4612		PL6162	VO-116	A16183	VA-310
C16108	VCA-1039	C35834	VCA-1142	L4619		PL6288	VO-132	A16184	VA-473
C16112	VCA-1096	C35845C	VCA-1194	L4748		PL6289	VO-151	A16200	VA-300
C16177	VCA-1097	C35856	VCA-1050	L4872		PL6290	VO-63	A16202	VA-301
C16203	VCA-1098	C35861	VCA-1144	L488		PL6293	VO-133	A16318	VA-316
C23122	VCA-1193	C35865	VCA-1047	L5313		PL6296	VO-114	A17780	VA-69
C23126	VCA-1179	C35898	VCA-1146	L5313		PL6311	VO-102	A19058	VA-344
C23133	VCA-1188	C36067	VCA-1062	L5313		PL8113	VO-77	A19154	VA-452
C23134	VCA-1181	C36080	VCA-1061	L5313		PL8154	VO-115	A21388	VA-471
C23135	VCA-1187	C36099	VCA-1059	L5335		PL8157	VO-142	A21413	VA-501
C23147	VCA-1191	C36115	VCA-1055	L5399		PL8161	VO-117	A21421	VA-499
C23150	VCA-2035	C36154	VCA-1078C	L5401		PL8165	VO-93	A21447	VA-497
C23151	VCA-2043	C36156	VCA-1073	L5522		PL8176	VO-86	A21482	VA-502
C23154	VCA-1190	C36157	VCA-1072	L5522		PL8179	VO-167	A23465	VA-69
C23168	VCA-1195	C36158	VCA-1071	L5522		PL8180	VO-86	A23465	VA-69
C25082	VCA-1001	C36174	VCA-1081	L5895		PL8182	VO-101	A23592	VA-66
C25245	VCA-1002	C36286	VCA-1174	L6128		PL8209	VO-104	A24278	VA-86
C25246	VCA-1021	C38155	VCA-1186	L6161		PL8812	VO-122	A24342	VA-85
C25387	VCA-1163	C38173	VCA-1173	L6291		PL9005	VO-123	A24343	VA-205
C25478	VCA-1020	C38175	VCA-1175	L7662		PL9011	VO-172	A24360	VA-84
C25480	VCA-1029	C38185	VCA-1176	L7819		PL9012	VO-169	A24372	VA-90
C25483	VCA-1161	C38188	VCA-1042	L8167		PL9169	VO-170	A24378	VA-70
C25490	VCA-1030	C38196C	VCA-1189	PH26		PUREPRO SELECT		A24468	VA-84
C25571	VCA-1101	C38214	VCA-1185	PH48R		L111S	VO-16	A24601	VA-414
C25572	VCA-1102	C38222	VCA-1067	PL4756		L111S	VO-55	A24633	VA-269
C25624C	VCA-1103	C38224	VCA-1184	PL4757		L195S	VO-1	A24645	VA-96
C25685	VCA-1104	C45383	VCA-1026	PL4758		L195S	VO-118	A24648	VA-416
C25764	VCA-1041	C45384	VCA-1017	PL4798		L195S	VO-118	A24675	VA-261
C25832	VCA-1106	C45459	VCA-1013	PL5234		L195S	VO-15	A24680	VA-83
C25836	VCA-1075	C45508	VCA-1040	PL5247		L195S	VO-15	A24690	VA-102
C25853	VCA-1109	C45654	VCA-1043	PL5251		L2222S	VO-200	A24712	VFAP-7854

CAUTION: For general references only. Check catalog for correct filter application. Any use of this interchange to determine filter application is done at the installers risk.

PRECAUCION: Solamente para referencias generales. Revise el catálogo para la correcta aplicación del filtro. Cualquier uso de la referencia cruzada para determinar la aplicación del filtro es riesgo del instalador. ATTENTION : Seulement pour les références d'ordre général. Contrôler l'application correcte du filtre avec le catalogue. Toute utilisation de moyens afin de déterminer l'application d'un filtre est faite aux risques de l'installateur.

Cross Reference

Table da equivalencias da fabricantes

Code de renvoi au fabricant

MFR'S NUMBER	REPLACEMENT NUMBER	MFR'S NUMBER	REPLACEMENT NUMBER	MFR'S NUMBER	REPLACEMENT NUMBER	MFR'S NUMBER	REPLACEMENT NUMBER	MFR'S NUMBER	REPLACEMENT NUMBER
PURULATOR		A25699	VA-224	A34839	VA-387	A35649	VA-214	A43558	VA-389
A24716	VA-401	A25781	VA-202	A34852	VFAP-917	A35670	VA-232	A44632	VA-88
A24720	VA-104	A25785	VA-329	A34862	VFAP-7912	A35671	VA-243	A44646	VA-158
A24722	VFAP-7892	A25786	VA-309	A34877	VA-89	A35672	VA-154	A44688	VA-207
A24731	VA-108	A25787	VA-351	A34878	VA-94	A35694	VA-371	A44690	VA-336
A24807	VA-370	A25792	VA-282	A34879	VA-114	A35700	VA-356	A44727	VA-105
A24819	VA-107	A25793	VA-362	A34883	VA-412	A35704	VA-367	A44729	VA-379
A24831	VFAP-7857	A25801	VA-374	A34886	VA-125	A35707	VA-203	A45047	VA-111
A24832	VA-106	A25802	VA-368	A34995	VA-124	A35775	VA-241	A45090	VA-92
A24858	VFAP-1612	A25804	VA-353	A35050	VA-128	A35779	VA-235	A45091	VA-320
A24859	VFAP-1613	A25825	VA-447	A35088	VA-404	A35783	VA-211	A45105	VFAP-7865
A24873	VA-113	A25833	VA-240	A35108	VFAP-7912	A35789	VA-278	A45206	VA-148
A24880	VA-109	A25841	VA-246	A35150	VA-135	A35798	VA-289	A45279	VA-339
A24881	VA-110	A26052	VA-250	A35155	VFAP-1643	A35811	VA-365	A45314	VA-259
A25042	VA-93	A26064	VA-202	A35192	VA-260	A35813	VA-448	A45315	VA-271
A25043	VA-120	A26067	VFA-1641	A35207	VA-131	A35816	VA-372	A45315	VA-324
A25048	VA-112	A26100	VA-366	A35219	VA-144	A35819	VA-258	A45381	VA-347
A25049	VFAP-7893	A26114	VA-257	A35227	VA-91	A35820	VA-236	A45387	VA-172
A25089	VA-129	A26118	VA-283	A35244	VA-153	A35824	VA-332	A45443	VA-400
A25107	VA-395	A26119	VA-275	A35258	VA-178	A35826	VA-318	A45457	VA-325
A25148	VFAP-7908	A26139	VA-391	A35265	VA-116	A35880	VA-263	A45488	VA-342
A25248	VA-117	A26140	VA-284	A35266	VA-147	A35883	VA-354	A45497	VA-335
A25249	VA-118	A26144	VA-319	A35267	VA-138	A35891	VA-375	A45512	VA-177
A25257	VA-136	A26153	VA-291	A35272	VA-410	A35907	VA-253	A45535	VA-174
A25301	VA-142	A26166	VA-334	A35278	VA-159	A36054	VA-384	A45555	VA-386
A25304	VA-397	A26169	VA-327	A35290	VA-114	A36055	VA-383	A45557	VA-330
A25306	VA-137	A26171	VA-292	A35291	VA-122	A36061	VA-294	A45568	VA-186
A25324	VA-140	A26172	VA-390	A35305	VA-146	A36101	VA-385	A45569	VA-382
A25352	VA-270	A26197	VA-297	A35323	VA-149	A36102	VA-280	A45620	VA-337
A25353	VA-150	A26199	VA-298	A35330	VA-78	A36103	VA-445	A45650	VA-209
A25372	VA-156	A26201	VA-299	A35359	VA-151	A36104	VA-378	A45673	VA-230
A25373	VA-152	A26273	VA-426	A35370	VA-190	A36109	VA-266	A45701	VA-238
A25374	VA-90	A26277	VA-427	A35375	VA-350	A36116	VA-273	A45780	VA-252
A25393	VA-399	A26280	VA-302	A35396	VA-154	A36120	VA-267	A45788	VA-315
A25394	VA-345	A26281	VA-303	A35397	VA-165	A36121	VA-245	A45794	VA-360
A25395	VA-193	A26282	VA-304	A35403	VA-192	A36124	VA-265	A45796	VA-323
A25398	VA-170	A26283	VA-164	A35414	VA-164	A36131	VA-255	A45800	VA-360
A25405	VA-155	A26306	VA-237	A35420	VA-166	A36146	VA-295	A45900	VA-444
A25418	VA-162	A26310	VA-184	A35421	VA-346	A36149	VA-288	A46056	VA-358
A25446	VA-167	A26312	VA-357	A35431	VA-176	A36151	VA-287	A46130	VA-254
A25451	VA-361	A26319	VA-424	A35432	VA-163	A36163	VA-285	A46143	VA-443
A25456	VA-196	A27399	VFAP-7912	A35433	VA-161	A36165	VA-286	A46145	VA-296
A25463	VA-171	A27765	VA-341	A35434	VA-185	A36167	VA-293	A46152	VA-296
A25467	VA-363	A27875	VA-395	A35440	VA-333	A36271	VA-429	A46279	VA-308
A25485	VA-167	A28163	VA-428	A35449	VA-279	A36272	VA-306	A46297	VA-312
A25499	VA-270	A28164	VA-428	A35461	VA-199	A36274	VA-307	A47039	VA-157
A25503	VA-183	A28168	VA-419	A35462	VA-160	A36275	VA-331	A47699	VA-380
A25507	VA-184	A28177	VA-438	A35468	VA-205	A36276	VA-393	A47753	VA-380
A25525	VA-194	A28192	VA-446	A35489	VA-322	A36308	VA-220	A48156	VA-430
A25538	VA-328	A28194	VA-432	A35513	VA-175	A36309	VA-221	A48171	VA-425
A25540	VA-370	A28199	VA-453	A35517	VA-247	A36320	VA-311	A48219	VA-462
A25554	VA-355	A28217	VA-435	A35528	VA-182	A37492	VA-314	A48220	VA-463
A25566	VA-197	A29151	VA-454	A35534	VA-206	A38189	VA-434	A48225	VA-451
A25567	VA-249	A29152	VA-456	A35546	VA-204	A38193	VA-449	A49061	VA-423
A25582	VA-215	A30067	VA-402	A35553	VA-179	A38195	VA-417	A49062	VA-396
A25584	VA-208	A31397	VA-437	A35556	VA-181	A38197	VA-431	A49146	VA-459
A25585	VA-184	A31433	VA-461	A35560	VA-180	A38218	VA-442	A49179	VA-465
A25587	VA-377	A31464	VA-498	A35578	VA-195	A38223	VA-453	A50091	VA-2
A25588	VA-188	A31467	VA-474	A35583	VA-216	A39060	VA-450	A50092	VA-403
A25594	VA-269	A33380	VA-44	A35589	VA-359	A39150	VA-466	A51462	VA-485
A25596	VA-226	A33590	VA-65	A35592	VA-198	A39155	VA-418	A52923	VA-411
A25634	VA-213	A33593	VA-413	A35595	VA-187	A39156	VA-458	A54314	VA-411
A25635	VA-229	A34361	VA-408	A35601	VA-228	A39166	VA-455	A54669	VA-97
A25647	VA-201	A34479	VA-78	A35602	VA-227	A39183	VA-464	A54855	VA-338
A25651	VA-202	A34629	VA-408	A35603	VA-200	A40004	VA-321	A55378	VA-111
A25652	VA-343	A34711	VA-340	A35625	VA-248	A41367	VA-488	A55380	VA-394
A25653	VA-212	A34715	VA-99	A35626	VA-365	A41378	VA-468	A55400	VA-169
A25655	VA-231	A34717	VA-98	A35633	VA-222	A41392	VA-467	A55521	VA-189
A25656	VA-210	A34721	VFAP-7859	A35638	VA-218	A41474	VA-469	A55539	VA-380
A25657	VA-242	A34799	VA-103	A35642	VA-223	A43195	VA-38	A55616	VA-364
A25698	VA-251	A34838	VA-132	A35645	VA-352	A43546	VA-321	A55696	VA-381

CAUTION: For general references only. Check catalog for correct filter application. Any use of this interchange to determine filter application is done at the installers risk.

PRECAUCION: Solamente para referencias generales. Revise el catálogo para la correcta aplicación del filtro. Cualquier uso de la referencia cruzada para determinar la aplicación del filtro es riesgo del instalador. ATTENTION : Seulement pour les références d'ordre général. Contrôler l'application correcte du filtre avec le catalogue. Toute utilisation de moyens afin de déterminer l'application d'un filtre est faite aux risques de l'installateur.

Cross Reference

Table da equivalencias da fabricantes

Code de renvoi au fabricant

MFR'S NUMBER	REPLACEMENT NUMBER	MFR'S NUMBER	REPLACEMENT NUMBER	MFR'S NUMBER	REPLACEMENT NUMBER	MFR'S NUMBER	REPLACEMENT NUMBER	MFR'S NUMBER	REPLACEMENT NUMBER
PUROLATOR		C25875	VCA-1114	C36115	VCA-1055	L14670	VO-95	L25609	VO-87
A55697	VA-239	C25876	VCA-1049	C36125C	VCA-1147	L14758	LC-833	L25646	VO-129
A55706	VA-364	C25877	VCA-1052	C36154	VCA-1078	L15309	VO-73	L25690	VO-130
A55799	VA-234	C25878	VCA-1054	C36154C	VCA-1078C	L15313	VO-65	L25692	VO-97
A55822	VA-219	C26073	VCA-1057	C36156	VCA-1073	L15315	VO-66	L25702	VO-96
A56164	VA-272	C26086	VCA-1115	C36157	VCA-1072	L15317	VO-86	L25848	VO-99
A56314	VA-264	C26087	VCA-1116	C36158	VCA-1071	L15317	VO-86	L25904	VO-131
A57556	VA-403	C26089	VCA-1117	C36174	VCA-1081	L15386	VO-76	L26127	VO-109
A58153	VA-457	C26155	VCA-1118	C36179	VCA-1075	L15436	VO-76	L26288	VO-132
A58172	VA-440	C26175	VCA-1177	C36286	VCA-1174	L15438	VO-119	L26293	VO-133
A59182	VA-490	C26176	VCA-1077	C37615C	VCA-1150	L15465	VO-82	L27190	VO-15
A63181	VA-45	C26185	VCA-1120	C38155	VCA-1186	L15505	VO-80	L27233	VO-159
A65716	VA-373	C26205C	VCA-1080	C38173	VCA-1173	L15607	VO-91	L27234	VO-95
A65814	VA-317	C28183	VCA-1171	C38175	VCA-1175	L15641	VO-120	L27252	VO-15
A65823	VA-349	C29064	VCA-1178	C38185	VCA-1176	L15830	VO-111	L27261	VO-95
A66313	VA-225	C31371	VCA-2043	C38188	VCA-1042	L15839	VO-98	L27642	VO-135
B23128	VA-48	C31380	VCA-1190	C38208	VCA-1179	L16160	VO-121	L27747	VO-150
B43127	VA-34	C31381	VCA-1191	C38214	VCA-1185	L16161	VO-122	L27826	VO-35
B43127M	VA-34	C31415	VCA-1062	C38216	VCA-1189	L16162	VO-116	L28161	VO-117
C14860	VCA-1157	C31434	VCA-2051	C38222	VCA-1067	L16291	VO-123	L28176	VO-165
C15388	VCA-1003	C31450	VCA-2055	C38224	VCA-1184	L16311	VO-102	L28180	VO-153
C15389	VCA-1008	C35402	VCA-1122	C38224C	VCA-1183	L17019	VO-95	L28209	VO-166
C15390	VCA-1167	C35413	VCA-1022K	C41451C	VCA-1188	L17200	VO-95	L28812	LC-834
C15439	VCA-1012	C35425	VCA-1060	C45383	VCA-1026	L17810	LC-833	L29169	VO-168
C15471	VCA-1164	C35426	VCA-1024	C45384	VCA-1017	L17819	VO-124	L29177	VO-173
C15506	VCA-1160	C35448	VCA-1022	C45459	VCA-1013	L18179	VO-167	L30001	VO-1
C15510	VCA-1162	C35448C	VCA-1165	C45508	VCA-1040	L18182	VO-164	L30005	VO-108
C15510C	VCA-1162	C35473	VCA-1123	C45527	VCA-1074	L18207	VO-95	L30040	VO-56
C15537	VCA-1056	C35477	VCA-1165	C45527C	VCA-1074	L19168	VO-25	L30042	VO-15
C15599	VCA-1170	C35479	VCA-1014	C45621	VCA-1172	L20020	VO-95	L30068	VO-163
C15659	VCA-1089	C35484	VCA-1124	C45654	VCA-1043	L20033	VO-108	L30119	VO-1
C15850	VCA-1048	C35484C	VCA-1124	C45662	VCA-1066	L20049	VO-65	L30141	VO-134
C15857	VCA-1036	C35491	VCA-1028	C45844C	VCA-1153	L20064	VO-15	L30165	VO-135
C15862	VCA-1053	C35494	VCA-1168	C45871	VCA-1038	L20073	VO-52	L30255	VO-86
C15868	VCA-1159	C35494C	VCA-1168	C46126	VCA-1076	L20081	VO-95	L30257	VO-15
C15873	VCA-1046	C35498	VCA-1125	C48162	VCA-1082	L20089	VO-118	L30288	VO-46
C16079	VCA-1093	C35504	VCA-1126	C49187C	VCA-1195	L20123	VO-108	L30341	VO-15
C16098	VCA-1094	C35504C	VCA-1126	C51395	VCA-1193	L20173	VO-55	L30381	VO-86
C16108	VCA-1039	C35509	VCA-1127	C59185	VCA-1181	L20195	VO-118	L31385	VO-172
C16112C	VCA-1096	C35509C	VCA-1127	F10131	VG-2	L20252	VO-15	L34631	VO-56
C16177	VCA-1097	C35516	VCA-1014	F33144	VG-14	L20253	VO-35	L34750	VO-136
C16203	VCA-1098	C35518	VCA-1129	F54714	VG-33	L20287	VO-19	L34756	VO-70
C25082	VCA-1001	C35519	VCA-1063	F63169	VG-16	L21350	VO-174	L34875	VO-95
C25245	VCA-1002	C35526	VCA-1131	F64702	VG-30	L21406	VO-98	L35098	VO-118
C25246	VCA-1021	C35530	VCA-1068	F64711	VG-32	L22167	VO-95	L35132	VO-56
C25387	VCA-1163	C35549	VCA-1133	L10017	VO-95	L22500	VO-88	L35234	VO-85
C25478	VCA-1020	C35549C	VCA-1133	L10018	VO-95	L22821	VO-40	L35280	VO-74
C25480	VCA-1029	C35576	VCA-1134	L10028	VO-25	L24007	VO-58	L35399	VO-75
C25483	VCA-1161	C35586C	VCA-1135	L10085	VO-37	L24011	VO-55	L35476	VO-78
C25490	VCA-1030	C35643	VCA-1070	L10111	VO-16	L24457	VO-25	L35495	VO-161
C25571	VCA-1101	C35644	VCA-1037	L10112	VO-16	L24458	VO-106	L35581	VO-85
C25572	VCA-1102	C35660	VCA-1051	L10193	VO-19	L24466	VO-15	L35593	VO-137
C25624	VCA-1103	C35661	VCA-1035	L10241	VO-25	L24484	VO-60	L35610	VO-90
C25624C	VCA-1103	C35667	VCA-1031	L10291	VO-27	L24651	VO-88	L35843	VO-138
C25685	VCA-1104	C35668	VCA-1022	L11403	VO-200	L25195	VO-95	L35894	VO-139
C25764	VCA-1041	C35674	VCA-1138	L11406	VO-98	L25230	VO-118	L35895	VO-101
C25770	VCA-1058	C35675	VCA-1139	L11411	VO-175	L25247	LC-8170	L35909	VO-140
C25832	VCA-1106	C35676	VCA-1065	L11424	VO-202	L25250	VO-150	L36135	VO-110
C25835	VCA-1103	C35677	VCA-2033	L12222	VO-88	L25251	LC-8445	L36289	VO-151
C25836	VCA-1075	C35677C	VCA-2033	L14006	VO-58	L25274	VO-67	L36290	VO-141
C25840	VCA-1158	C35834	VCA-1142	L14459	VO-106	L25276	VO-69	L36296	VO-114
C25840C	VCA-1108	C35845	VCA-1194	L14459	VO-52	L25277	VO-103	L37560	VO-136
C25851	VCA-1031	C35856	VCA-1050	L14460	VO-106	L25288	VO-108	L37673	VO-15
C25853	VCA-1109	C35860	VCA-1155	L14476	VO-40	L25316	VO-127	L38113	VO-77
C25858	VCA-1064	C35861	VCA-1144	L14477	VO-40	L25401	VO-93	L38154	VO-115
C25859	VCA-1068	C35865	VCA-1047	L14610	VO-106	L25511	VO-128	L38157	VO-142
C25863	VCA-1110	C35872	VCA-1145	L14612	VO-106	L25522	VO-86	L38165	VO-149
C25864	VCA-1034	C35898	VCA-1146	L14615	VO-106	L25536	VO-69	L38167	VO-170
C25869	VCA-1069	C36067	VCA-1062	L14619	VO-35	L25545	VO-150	L38257	VO-15
C25870	VCA-1044	C36080	VCA-1061	L14620	VO-106	L25564	VO-112	L40313	VO-162
C25874	VCA-1113	C36099	VCA-1059	L14622	VO-106	L25608	VO-84	L40316	VO-15

CAUTION: For general references only. Check catalog for correct filter application. Any use of this interchange to determine filter application is done at the installers risk.

PRECAUCION: Solamente para referencias generales. Revise el catálogo para la correcta aplicación del filtro. Cualquier uso de la referencia cruzada para determinar la aplicación del filtro es riesgo del instalador. ATTENTION : Seulement pour les références d'ordre général. Contrôler l'application correcte du filtre avec le catalogue. Toute utilisation de moyens afin de déterminer l'application d'un filtre est faite aux risques de l'installateur.

Cross Reference

Table da equivalencias da fabricantes

Code de renvoi au fabricant

MFR'S NUMBER	REPLACEMENT NUMBER	MFR'S NUMBER	REPLACEMENT NUMBER	MFR'S NUMBER	REPLACEMENT NUMBER	MFR'S NUMBER	REPLACEMENT NUMBER	MFR'S NUMBER	REPLACEMENT NUMBER
PULORATOR		PSL14610	VO-106	QSA45387	VA-172	QSA9269	VA-169	QS6847	VO-70
L41404	VO-169	PSL14612	VO-106	QSA45512	VA-177	QSA9286	VA-151	QS6848	VO-62
L44422	VO-64	PSL14670	VO-95	QSA4939	VA-408	QSA9332	VA-162	QS7073	LC-833
L44748	VO-143	PSL15313	VO-65	QSA5056	VA-205	QSA9345	VA-161	QS7317	VO-106
L44757	VO-62	PSL15315	VO-66	QSA5057	VA-413	QSA9359	VA-170	QS7328	VO-95
L44798	VO-144	PSL15436	VO-76	QSA5058	VA-66	QSA9360	VA-163	QS8A	VO-1
L44872	VO-63	PSL15505	VO-80	QSA5125	VA-414	QSA9400	VA-167	QS8081	LC-8170
L45262	VO-146	PSL15607	VO-91	QSA5350	VFAP-7865	QSA9401	VA-160	QS8158	VO-150
L45308	VO-71	PSL20195	VO-118	QSA5466	VFAP-7892	QSG3727	VG-14	QS8481	VO-69
L45335	VO-64	PSL20252	VO-15	QSA5595	VFAP-7893	QSG3802A	VG-16	QS8530	VO-71
L45408	VO-143	PSL22500	VO-88	QSA6366	VA-70	QS13	VO-56	QS8712	VO-66
L45515	VO-81	PSL24011	VO-55	QSA6395	VA-84	QS14006	VO-58	QS8765	VO-67
L45526	VO-81	PSL24457	VO-25	QSA6479	VA-78	QS14460	VO-106	QS8806	VO-73
L45579	VO-94	PSL24651	VO-88	QSA6555	VA-88	QS14461	VO-106	QS8873	VO-65
L45598	VO-92	PSL25247	LC-8170	QSA6626	VA-269	QS14610	VO-106	QS8994	VO-95
L46066	VO-162	PSL25274	VO-67	QSA6690	VA-96	QS14612	VO-106	QS9018	VO-76
L46128	VO-104	PSL25277	VO-103	QSA6807	VA-83	QS15505	VO-80	QS9100	VO-75
L54998	VO-162	PSL25288	VO-108	QSA6828	VA-416	QS16	VO-95	ROYAL PURPLE	
L59008	VO-156	PSL25608	VO-84	QSA6850	VA-97	QS163	VO-91	10-2808	VO-106
ML16810	VO-106	PSL30001	VO-1	QSA7094	VA-101	QS169	VO-96	10-2835	VO-25
ML16822	VO-25	PSL34631	VO-56	QSA7142	VA-99	QS171	VO-98	10-2840	VO-40
ML16831	VO-25	PSL35399	VO-75	QSA7167	VA-98	QS173	VO-88	10-2867	VO-106
ML16833	VO-106	PSL35581	VO-85	QSA7174	VA-103	QS174	VO-99	10-2876	VO-106
PM1697	VA-69	PSL35610	VO-90	QSA7351	VA-102	QS177	VO-104	10-2876	VO-106
PULORATOR BOSS		PSL36135	VO-110	QSA7365	VFAP-7854	QS179	VO-109	10-3244	VO-76
PBL10111	VO-16	PSL45335	VO-64	QSA7414	VA-107	QS180	VO-110	10-44	VO-108
PBL10241	VO-25	PSL45526	VO-81	QSA7417	VFAP-7859	QS182	VO-106	10-44	VO-58
PBL11403	VO-200	QUAKER STATE		QSA7420	VA-113	QS184	VO-114	10-454	VO-65
PBL12222	VO-88	QSA160	VA-321	QSA7421	VA-108	QS2	VO-88	10-454	VO-65
PBL14006	VO-58	QSA192	VA-402	QSA7426	VA-106	QS25	VO-108	10-47	VO-16
PBL14461	VO-106	QSA24720	VA-104	QSA7431	VA-124	QS25230	VO-118	10-48	VO-152
PBL14476	VO-40	QSA24831	VFAP-7857	QSA7440	VA-105	QS2825	VO-15	10-48	VO-160
PBL14477	VO-40	QSA24858	VFAP-1612	QSA7597	VA-109	QS2849A	VO-52	10-48	VO-200
PBL14610	VO-106	QSA24859	VFAP-1613	QSA7598	VA-110	QS2870A	VO-15	10-48	VO-88
PBL14612	VO-106	QSA25042	VA-93	QSA7600	VA-338	QS2951	VO-40	10-980	VO-102
PBL14615	VO-106	QSA25048	VA-112	QSA7614	VA-120	QS30	VO-65	20-2009	VO-86
PBL14661	VO-106	QSA25089	VA-129	QSA7620	VA-132	QS3387A	VO-16	20-2009	VO-86
PBL14670	VO-95	QSA25148	VFAP-7908	QSA7651	VA-157	QS3429	VO-108	20-2129	VO-67
PBL15313	VO-65	QSA25395	VA-193	QSA7764	VA-135	QS34875	VO-95	20-253	VO-93
PBL15436	VO-76	QSA25456	VA-196	QSA7774	VA-114	QS3531	VO-27	20-253	VO-95
PBL15607	VO-91	QSA25463	VA-171	QSA8037	VA-320	QS3569	VO-15	20-253	VO-95
PBL16311	VO-102	QSA25499	VA-270	QSA8069	VA-144	QS3593A	VO-106	20-253	VO-95
PBL20195	VO-118	QSA25503	VA-183	QSA8121	VA-147	QS3600	VO-118	20-400	VO-118
PBL20252	VO-15	QSA25507	VA-184	QSA8133	VA-117	QS3614	VO-25	20-400	VO-118
PBL22500	VO-88	QSA26067	VFA-1641	QSA8141	VFA-1641	QS3675A	VO-108	20-500	VO-201
PBL24011	VO-55	QSA326	VA-2	QSA8162	VA-131	QS3682	VO-25	20-500	VO-88
PBL24457	VO-25	QSA327	VA-403	QSA8205	VA-129	QS3766	VO-46	20-500	VO-88
PBL24651	VO-88	QSA34839	VA-387	QSA8221	VA-91	QS3950	VO-19	20-51A	VO-55
PBL25247	LC-8170	QSA34877	VA-89	QSA8269	VA-410	QS3970	VO-37	20-561	VO-15
PBL25277	VO-103	QSA34878	VA-94	QSA8475	VA-118	QS3976	VO-64	20-59	VO-108
PBL25288	VO-108	QSA34879	VA-114	QSA8547	VA-136	QS3980	VO-55	20-8170	LC-8170
PBL25608	VO-84	QSA34883	VA-412	QSA8548	VA-178	QS3985	VO-35	20-820	VO-88
PBL25609	VO-87	QSA34886	VA-125	QSA8602	VA-138	QS43	VO-95	20-820	VO-88
PBL25848	VO-99	QSA3492	VA-45	QSA8606	VA-116	QS4386	VO-40	20-967	VO-84
PBL30001	VO-1	QSA3501	VA-411	QSA8747	VA-156	QS44872	VO-63	20-968	VO-87
PBL34631	VO-56	QSA35155	VFAP-1643	QSA8754	VA-78	QS45335	VO-64	30-1218	VO-56
PBL35399	VO-75	QSA35192	VA-260	QSA8755	VA-259	QS45515	VO-81	30-1218	VO-56
PBL35581	VO-85	QSA35244	VA-153	QSA8760	VA-270	QS45516	VO-84	30-2999	VO-75
PBL35895	VO-101	QSA35403	VA-192	QSA8766	VA-152	QS45517	VO-87	30-8A	VO-1
PBL38165	VO-149	QSA35528	VA-182	QSA8805	VA-137	QS45518	VO-88	30-8A	VO-15
PBL44872	VO-63	QSA35559	VA-40	QSA8817	VA-164	QS45519	VO-90	40-2051	VO-104
PBL45526	VO-81	QSA3588	VA-38	QSA8911	VA-165	QS45520	VO-102	40-780	VO-64
PBL46128	VO-104	QSA3647	VA-44	QSA8918	VA-146	QS45521	VO-85	40-979	VO-96
PULORATOR SYNTHETIC		QSA3660	VA-69	QSA8925	VA-122	QS45522	VO-81	50-2017	VO-81
PSL10111	VO-16	QSA3901	VA-90	QSA8956	VA-142	QS4681	VO-15	50-2286	VO-63
PSL10241	VO-25	QSA3902	VA-85	QSA8969	VA-140	QS4967	VO-40	SAAB	
PSL12222	VO-88	QSA3914	VFAP-917	QSA8970	VA-166	QS5	VO-56	0204495	VO-95
PSL14006	VO-58	QSA3916	VA-65	QSA8997	VA-149	QS5320	LC-834	11436936	VO-95
PSL14459	VO-106	QSA4309	VA-86	QSA9053	VA-155	QS5618	VO-86	30548485	VO-25
PSL14476	VO-40	QSA45047	VA-111	QSA9054	VA-154	QS6552	VO-60	32005769	VO-106
PSL14477	VO-40	QSA45090	VA-92	QSA9113	VA-150	QS6607	VO-106	32005786	VA-86

CAUTION: For general references only. Check catalog for correct filter application. Any use of this interchange to determine filter application is done at the installers risk.

PRECAUCION: Solamente para referencias generales. Revise el catálogo para la correcta aplicación del filtro. Cualquier uso de la referencia cruzada para determinar la aplicación del filtro es riesgo del instalador. ATTENTION : Seulement pour les références d'ordre général. Contrôler l'application correcte du filtre avec le catalogue. Toute utilisation de moyens afin de déterminer l'application d'un filtre est faite aux risques de l'installateur.

Cross Reference

Table da equivalencias da fabricantes

Code de renvoi au fabricant

MFR'S NUMBER	REPLACEMENT NUMBER	MFR'S NUMBER	REPLACEMENT NUMBER	MFR'S NUMBER	REPLACEMENT NUMBER	MFR'S NUMBER	REPLACEMENT NUMBER	MFR'S NUMBER	REPLACEMENT NUMBER
SAAB		AF4690	VA-102	AF5324	VA-140	AF5584	VA-208	AF5824	VA-332
4502696	VO-16	AF4711	VA-340	AF5352	VA-270	AF5587	VA-377	AF5825	VA-447
4602696	VO-16	AF4712	VA-404	AF5353	VA-150	AF5588	VA-188	AF5826	VA-318
55560202	VO-25	AF4712	VFAP-7854	AF5359	VA-151	AF5589	VA-359	AF5833	VA-240
729854	VO-88	AF4715	VA-99	AF5363	VA-191	AF5592	VA-198	AF5841	VA-246
800334	VO-95	AF4717	VA-98	AF5370	VA-190	AF5595	VA-187	AF5880	VA-263
8349409	VO-95	AF4720	VA-104	AF5372	VA-156	AF5596	VA-226	AF5883	VA-354
8803348	VO-95	AF4721	VFAP-7859	AF5373	VA-152	AF5601	VA-228	AF5891	VA-375
9144445	VO-25	AF4722	VFAP-7892	AF5375	VA-350	AF5602	VA-227	AF5900	VA-444
9309576	VO-95	AF4727	VA-105	AF5380	VA-394	AF5603	VA-200	AF5907	VA-253
93184334	VO-76	AF4729	VA-379	AF5381	VA-347	AF5604	VA-217	AF6052	VA-250
93186310	VO-67	AF4731	VA-108	AF5387	VA-172	AF5620	VA-337	AF6054	VA-384
93186554	VO-25	AF4799	VA-103	AF5393	VA-399	AF5625	VA-248	AF6055	VA-383
9318723	VO-16	AF4807	VA-370	AF5394	VA-345	AF5626	VA-365	AF6056	VA-358
SATURN		AF4819	VA-107	AF5395	VA-193	AF5633	VA-222	AF6061	VA-294
12582255	VO-106	AF4831	VFAP-7857	AF5396	VA-154	AF5634	VA-213	AF6065	VA-388
12605566	VO-76	AF4832	VA-106	AF5397	VA-165	AF5635	VA-229	AF6067	VFA-1641
15800986	VA-211	AF4838	VA-132	AF5398	VA-170	AF5638	VA-218	AF6093	VA-313
15893542	VA-211	AF4839	VA-387	AF5400	VA-169	AF5642	VA-223	AF6094	VA-268
19130294	VCA-1075	AF4852	VFAP-917	AF5403	VA-192	AF5645	VA-352	AF6100	VA-366
19160307	VA-175	AF4855	VA-338	AF5405	VA-155	AF5647	VA-201	AF6101	VA-385
19210284	VO-16	AF4858	VFAP-1612	AF5414	VA-164	AF5649	VA-214	AF6102	VA-280
19210285	VO-108	AF4859	VFAP-1613	AF5418	VA-162	AF5650	VA-209	AF6103	VA-445
21000872	VO-25	AF4873	VA-113	AF5420	VA-166	AF5651	VA-202	AF6104	VA-378
21000938	VA-101	AF4877	VA-89	AF5421	VA-346	AF5652	VA-343	AF6109	VA-266
21018801	VO-76	AF4878	VA-94	AF5431	VA-176	AF5653	VA-212	AF6114	VA-257
21018826	VO-73	AF4879	VA-114	AF5432	VA-163	AF5655	VA-231	AF6116	VA-273
22665802	VCA-1030	AF4880	VA-109	AF5433	VA-161	AF5656	VA-210	AF6118	VA-283
22676970	VA-176	AF4881	VA-110	AF5434	VA-185	AF5657	VA-242	AF6119	VA-275
22679620	VA-175	AF4883	VA-412	AF5440	VA-333	AF5669	VA-244	AF6120	VA-267
22685727	VO-76	AF4886	VA-125	AF5443	VA-400	AF5670	VA-232	AF6121	VA-245
52493319	VCA-1065	AF4995	VA-124	AF5446	VA-167	AF5671	VA-243	AF6124	VA-265
90464424	VCA-1029	AF5042	VA-93	AF5449	VA-279	AF5673	VA-230	AF6130	VA-254
90571362	VA-151	AF5043	VA-120	AF5451	VA-361	AF5694	VA-371	AF6131	VA-255
93185674	VO-98	AF5047	VA-111	AF5456	VA-196	AF5696	VA-381	AF6139	VA-391
96815102	VA-236	AF5048	VA-112	AF5457	VA-325	AF5697	VA-239	AF6140	VA-284
SERVICE CHAMP		AF5049	VFAP-7893	AF5461	VA-199	AF5698	VA-251	AF6143	VA-443
AF1367	VA-488	AF5050	VA-128	AF5462	VA-160	AF5699	VA-224	AF6144	VA-319
AF1392	VA-467	AF5089	VA-129	AF5463	VA-171	AF5700	VA-356	AF6145	VA-296
AF1413	VA-501	AF5090	VA-92	AF5467	VA-363	AF5701	VA-238	AF6146	VA-295
AF2923	VA-411	AF5091	VA-320	AF5468	VA-205	AF5703	VA-233	AF6149	VA-288
AF3192	VA-40	AF5105	VFAP-7865	AF5488	VA-342	AF5704	VA-367	AF6151	VA-287
AF3195	VA-38	AF5107	VA-395	AF5489	VA-322	AF5706	VA-364	AF6153	VA-291
AF3380	VA-44	AF5108	VFAP-7912	AF5497	VA-335	AF5707	VA-203	AF6163	VA-285
AF3465	VA-69	AF5148	VFAP-7908	AF5503	VA-183	AF5716	VA-373	AF6165	VA-286
AF3558	VA-389	AF5150	VA-135	AF5507	VA-184	AF5775	VA-241	AF6166	VA-334
AF3590	VA-65	AF5155	VFAP-1643	AF5512	VA-177	AF5778	VA-326	AF6167	VA-293
AF3592	VA-66	AF5192	VA-260	AF5512HD	VA-272	AF5779	VA-235	AF6168	VA-290
AF3593	VA-413	AF5206	VA-148	AF5513	VA-175	AF5780	VA-252	AF6169	VA-327
AF4	VA-321	AF5207	VA-131	AF5517	VA-247	AF5783	VA-211	AF6171	VA-292
AF4278	VA-86	AF5219	VA-144	AF5521	VA-189	AF5785	VA-329	AF6172	VA-390
AF4342	VA-85	AF5227	VA-91	AF5525	VA-194	AF5786	VA-309	AF6183	VA-310
AF4343	VA-205	AF5244	VA-153	AF5528	VA-182	AF5787	VA-351	AF6184	VA-473
AF4361	VA-408	AF5248	VA-117	AF5534	VA-206	AF5788	VA-315	AF6197	VA-297
AF4372	VA-90	AF5249	VA-118	AF5535	VA-174	AF5789	VA-278	AF6199	VA-298
AF4378	VA-70	AF5257	VA-136	AF5538	VA-328	AF5792	VA-282	AF6200	VA-300
AF4468	VA-84	AF5258	VA-178	AF5539	VA-380	AF5793	VA-362	AF6201	VA-299
AF4479	VA-78	AF5265	VA-116	AF5546	VA-204	AF5794	VA-360	AF6202	VA-301
AF4601	VA-414	AF5266	VA-147	AF5553	VA-179	AF5796	VA-323	AF6271	VA-429
AF4622	VA-274	AF5267	VA-138	AF5554	VA-355	AF5798	VA-289	AF6272	VA-306
AF4632	VA-88	AF5272	VA-410	AF5555	VA-386	AF5799	VA-234	AF6273	VA-426
AF4633	VA-269	AF5278	VA-159	AF5556	VA-181	AF5801	VA-374	AF6274	VA-307
AF4645	VA-401	AF5279	VA-339	AF5557	VA-330	AF5802	VA-368	AF6275	VA-331
AF4645	VA-96	AF5291	VA-122	AF5560	VA-180	AF5804	VA-353	AF6276	VA-393
AF4646	VA-158	AF5301	VA-142	AF5566	VA-197	AF5813	VA-448	AF6277	VA-427
AF4648	VA-416	AF5304	VA-397	AF5567	VA-249	AF5814	VA-317	AF6279	VA-308
AF4650	VA-101	AF5305	VA-146	AF5568	VA-186	AF5816	VA-372	AF6280	VA-302
AF4669	VA-97	AF5306	VA-137	AF5569	VA-382	AF5819	VA-258	AF6281	VA-303
AF4675	VA-261	AF5314	VA-259	AF5578	VA-195	AF5820	VA-236	AF6282	VA-304
AF4680	VA-83	AF5315	VA-324	AF5582	VA-215	AF5822	VA-219	AF6283	VA-305
AF4688	VA-207	AF5323	VA-149	AF5583	VA-216	AF5823	VA-349	AF6297	VA-312

CAUTION: For general references only. Check catalog for correct filter application. Any use of this interchange to determine filter application is done at the installers risk.
 PRECAUCION: Solamente para referencias generales. Revise el catálogo para la correcta aplicación del filtro. Cualquier uso de la referencia cruzada para determinar la aplicación del filtro es riesgo del instalador. ATTENTION : Seulement pour les références d'ordre général. Contrôler l'application correcte du filtre avec le catalogue. Toute utilisation de moyens afin de déterminer l'application d'un filtre est faite aux risques de l'installateur.

Cross Reference

Table da equivalencias da fabricantes

Code de renvoi au fabricant

MFR'S NUMBER	REPLACEMENT NUMBER	MFR'S NUMBER	REPLACEMENT NUMBER	MFR'S NUMBER	REPLACEMENT NUMBER	MFR'S NUMBER	REPLACEMENT NUMBER	MFR'S NUMBER	REPLACEMENT NUMBER
SERVICE CHAMP		CF5438	VO-119	C16112	VCA-1096	C35675	VCA-1139	OF4422	VO-64
AF6306	VA-237	CF5465	VO-82	C16177	VCA-1097	C35676	VCA-1065	OF4457	VO-25
AF6308	VA-220	CF5476	VO-78	C16203	VCA-1098	C35677	VCA-2033	OF4459	VO-106
AF6309	VA-221	CF5505	VO-80	C25082	VCA-1001	C35834	VCA-1142	OF4477	VO-40
AF6312	VA-357	CF5511	VO-128	C25245	VCA-1002	C35845	VCA-1194	OF4484	VO-60
AF6313	VA-225	CF5515	VO-81	C25246	VCA-1021	C35856	VCA-1050	OF4619	VO-35
AF6314	VA-264	CF5564	VO-112	C25387	VCA-1163	C35860	VCA-1155	OF4622	VO-106
AF6318	VA-316	CF5579	VO-94	C25478	VCA-1020	C35861	VCA-1144	OF4622	VO-106
AF6319	VA-424	CF5593	VO-137	C25480	VCA-1029	C35865	VCA-1047	OF4622	VO-106
AF6320	VA-311	CF5598	VO-92	C25483	VCA-1161	C35872	VCA-1145	OF4651	VO-88
AF67	VA-402	CF5607	VO-91	C25490	VCA-1030	C35898	VCA-1146	OF4670	VO-95
AF7039	VA-157	CF5608	VO-84	C25571	VCA-1101	C36067	VCA-1062	OF4670	VO-95
AF7492	VA-314	CF5609	VO-87	C25572	VCA-1102	C36080	VCA-1061	OF4670	VO-95
AF7765	VA-341	CF5610	VO-90	C25624	VCA-1103	C36099	VCA-1059	OF4872	VO-93
AF8153	VA-457	CF5641	VO-120	C25685	VCA-1104	C36115	VCA-1055	OF5313	VO-65
AF8156	VA-430	CF5646	VO-129	C25764	VCA-1041	C36125	VCA-1147	OF5313	VO-65
AF8163	VA-428	CF5690	VO-130	C25832	VCA-1066	C36154	VCA-1078C	OF5399	VO-75
AF8168	VA-419	CF5692	VO-97	C25836	VCA-1075	C36156	VCA-1073	OF5401	VO-93
AF8171	VA-425	CF5702	VO-96	C25840	VCA-1158	C36157	VCA-1072	OF5408	VO-143
AF8172	VA-440	CF5830	VO-111	C25853	VCA-1109	C36158	VCA-1071	OF5522	VO-86
AF8177	VA-438	CF5839	VO-98	C25858	VCA-1064	C36174	VCA-1081	OF5522	VO-86
AF8189	VA-434	CF5843	VO-138	C25863	VCA-1110	C36286	VCA-1174	OF5895	VO-101
AF8192	VA-446	CF5848	VO-99	C25864	VCA-1034	C38155	VCA-1186	OF6128	VO-104
AF8194	VA-432	CF5904	VO-131	C25869	VCA-1069	C38173	VCA-1173	OF6161	VO-122
AF8195	VA-417	CF5909	VO-140	C25870	VCA-1044	C38175	VCA-1175	OF6291	VO-123
AF8197	VA-431	CF6127	VO-109	C25874	VCA-1113	C38185	VCA-1176	OF7662	VO-52
AF8217	VA-435	CF6135	VO-110	C25875	VCA-1114	C38188	VCA-1042	OF7819	VO-124
AF8219	VA-462	CF6160	VO-121	C25876	VCA-1049	C38196	VCA-1189	OF8167	VO-170
AF8220	VA-463	CF6162	VO-116	C25877	VCA-1052	C38208	VCA-1179	WAF10025	VA-502
AF8223	VA-453	CF6288	VO-132	C25878	VCA-1054	C38214	VCA-1185	WAF10031	VA-503
AF8225	VA-451	CF6289	VO-151	C26073	VCA-1057	C38222	VCA-1067	WAF10032	VA-504
AF9058	VA-344	CF6290	VO-141	C26086	VCA-1115	C38224	VCA-1184	WAF2944	VA-336
AF9060	VA-450	CF6293	VO-133	C26087	VCA-1116	C45383	VCA-1166	WAF3201	VA-468
AF9062	VA-396	CF6296	VO-114	C26089	VCA-1117	C45384	VCA-1017	WAF3202	VA-471
AF91	VA-2	CF6311	VO-102	C26155	VCA-1118	C45459	VCA-1013	WAF3226	VA-474
AF9146	VA-459	CF8113	VO-77	C26175	VCA-1177	C45508	VCA-1040	WAF3617	VA-423
AF9150	VA-466	CF8154	VO-115	C26176	VCA-1077	C45527	VCA-1074	WAF5213	VA-392
AF9152	VA-456	CF8157	VO-142	C26185	VCA-1120	C45621	VCA-1172	WAF5225	VA-460
AF9154	VA-452	CF8161	VO-117	C26205	VCA-1080	C45654	VCA-1043	WAF5231	VA-437
AF9155	VA-418	CF8165	VO-149	C28183	VCA-1171	C45662	VCA-1066	WAF5252	VA-485
AF9156	VA-458	CF8176	VO-165	C29064	VCA-1178	C45844	VCA-1153	WAF5264	VA-454
AF9166	VA-455	CF8179	VO-167	C31371	VCA-2043	C45871	VCA-1038	WAF5271	VA-461
AF9179	VA-465	CF8180	VO-153	C31380	VCA-1190	C46126	VCA-1076	WAF5273	VA-470
AF9182	VA-490	CF8182	VO-164	C31381	VCA-1191	C48162	VCA-1082	WAF5277	VA-499
AF9183	VA-464	CF8209	VO-166	C35402	VCA-1122	C51395	VCA-1193	WAF5286	VA-500
AF92	VA-403	CF85	VO-37	C35413	VCA-1022K	M1-113	VO-152	WAF5293	VA-498
CAF10004	VCA-2055	CF8812	LC-834	C35425	VCA-1060	M1-210	VO-88	WAF5296	VA-497
CAF10009	VCA-2051	CF9169	VO-168	C35426	VCA-1024	OF111	VO-16	WAF5699	VA-442
CAF1944	VCA-1181	CF9177	VO-173	C35448	VCA-1022	OF111	VO-55	WLAF3231	VA-469
CAF1949	VCA-1188	C14860	VCA-1157	C35473	VCA-1123	OF165	VO-135	WPH2878	VO-175
CAF1950	VCA-2035	C15388	VCA-1003	C35477	VCA-1165	OF193	VO-19	WPH488	VO-160
CAF1957	VCA-1195	C15389	VCA-1008	C35479	VCA-1014	OF2222	VO-200	WP1070	VO-169
CF1350	VO-174	C15390	VCA-1167	C35484	VCA-1124	OF2222	VO-201	52066	VG-14
CF1385	VO-172	C15439	VCA-1012	C35491	VCA-1028	OF2222	VO-88	52073	VG-33
CF4756	VO-70	C15471	VCA-1164	C35494	VCA-1168	OF2222	VO-88	52075	VG-30
CF4757	VO-62	C15506	VCA-1160	C35498	VCA-1125	OF2400	VO-88	54062	VG-16
CF4758	LC-833	C15510	VCA-1162	C35509	VCA-1127	OF241	VO-1	54066	VG-32
CF4798	VO-144	C15510	VCA-1162	C35509	VCA-1127	OF241	VO-118	SERVICE CHAMP HP	
CF5234	VO-85	C15537	VCA-1056	C35518	VCA-1129	OF241	VO-118	HP111	VO-16
CF5247	LC-8170	C15599	VCA-1170	C35519	VCA-1063	OF241	VO-15	HP111	VO-55
CF5250	VO-150	C15637	VCA-1156	C35526	VCA-1131	OF241	VO-25	HP2222	VO-152
CF5251	LC-8445	C15659	VCA-1089	C35530	VCA-1068	OF2500	VO-88	HP2222	VO-200
CF5274	VO-67	C15850	VCA-1048	C35549	VCA-1133	OF257	VO-15	HP2222	VO-88
CF5277	VO-103	C15857	VCA-1036	C35576	VCA-1134	OF288	VO-46	HP2222	VO-88
CF5277	VO-69	C15862	VCA-1053	C35586	VCA-1135	OF291	VO-27	HP241	VO-1
CF5280	VO-74	C15868	VCA-1159	C35643	VCA-1070	OF33	VO-108	HP241	VO-118
CF5308	VO-71	C15873	VCA-1046	C35644	VCA-1037	OF381	VO-86	HP241	VO-118
CF5309	VO-73	C16079	VCA-1093	C35660	VCA-1051	OF40A	VO-56	HP241	VO-15
CF5315	VO-66	C16098	VCA-1094	C35661	VCA-1035	OF40A	VO-56	HP241	VO-25
CF5316	VO-127	C16108	VCA-1039	C35667	VCA-1031	OF4006	VO-108	HP241	VO-95
CF5436	VO-76	C16112	VCA-1096	C35674	VCA-1138	OF4006	VO-58	HP4006	VO-108

CAUTION: For general references only. Check catalog for correct filter application. Any use of this interchange to determine filter application is done at the installers risk.

PRECAUCION: Solamente para referencias generales. Revise el catálogo para la correcta aplicación del filtro. Cualquier uso de la referencia cruzada para determinar la aplicación del filtro es riesgo del instalador. ATTENTION : Seulement pour les références d'ordre général. Contrôler l'application correcte du filtre avec le catalogue. Toute utilisation de moyens afin de déterminer l'application d'un filtre est faite aux risques de l'installateur.

Cross Reference

Table da equivalencias da fabricantes

Code de renvoi au fabricant

MFR'S NUMBER	REPLACEMENT NUMBER	MFR'S NUMBER	REPLACEMENT NUMBER	MFR'S NUMBER	REPLACEMENT NUMBER	MFR'S NUMBER	REPLACEMENT NUMBER	MFR'S NUMBER	REPLACEMENT NUMBER
SERVICE CHAMP HP		MA10424	VA-432	MA4859	VFAP-1613	MA5420	VA-166	MA5652	VA-343
HP4006	VO-58	MA10426	VA-417	MA4873	VA-113	MA5421	VA-346	MA5653	VA-212
HP4422	VO-64	MA10460	VA-418	MA4878	VA-94	MA5431	VA-176	MA5655	VA-231
HP4459	VO-106	MA10467	VA-431	MA4879	VA-114	MA5432	VA-163	MA5656	VA-210
HP4477	VO-40	MA10469	VA-453	MA4880	VA-109	MA5433	VA-161	MA5657	VA-242
HP4622	VO-106	MA10481	VA-334	MA4881	VA-110	MA5434	VA-185	MA5669	VA-244
HP4622	VO-106	MA10486	VA-456	MA4883	VA-412	MA5440	VA-333	MA5670	VA-232
HP4622	VO-106	MA10492	VA-455	MA4886	VA-125	MA5443	VA-400	MA5671	VA-243
HP4651	VO-88	MA10496	VA-454	MA4995	VA-124	MA5446	VA-167	MA5672	VA-154
HP4651	VO-88	MA10498	VA-464	MA5042	VA-93	MA5449	VA-279	MA5673	VA-230
HP5234	VO-85	MA10499	VA-459	MA5043	VA-120	MA5451	VA-361	MA5696	VA-381
HP5247	LC-8170	MA10578	VA-465	MA5048	VA-112	MA5456	VA-196	MA5697	VA-239
HP5274	VO-67	MA10579	VA-463	MA5049	VFAP-7893	MA5457	VA-325	MA5698	VA-251
HP5277	VO-103	MA10583	VA-461	MA5050	VA-128	MA5461	VA-199	MA5699	VA-224
HP5277	VO-69	MA10601	VA-423	MA5089	VA-129	MA5463	VA-171	MA5700	VA-356
HP5399	VO-75	MA10645	VA-474	MA5090	VA-92	MA5467	VA-363	MA5701	VA-238
HP5436	VO-76	MA10648	VA-468	MA5091	VA-320	MA5488	VA-342	MA5703	VA-233
HP5505	VO-80	MA10651	VA-467	MA5105	VFAP-7865	MA5497	VA-335	MA5704	VA-367
HP5515	VO-81	MA15873	VCA-1046	MA5148	VFAP-7908	MA5499	VA-270	MA5707	VA-203
HP5607	VO-91	MA2923	VA-411	MA5150	VA-135	MA5503	VA-183	MA5716	VA-373
HP5608	VO-84	MA3192	VA-40	MA5155	VFAP-1643	MA5512	VA-177	MA5775	VA-241
HP5609	VO-87	MA3195	VA-38	MA5192	VA-260	MA5513	VA-175	MA5779	VA-235
HP5610	VO-90	MA3380	VA-44	MA5192	VA-322	MA5517	VA-247	MA5780	VA-252
HP5702	VO-96	MA3462	VA-160	MA5206	VA-148	MA5521	VA-189	MA5781	VA-390
HP5839	VO-98	MA3465	VA-69	MA5207	VA-131	MA5525	VA-194	MA5783	VA-211
HP5848	VO-99	MA3558	VA-389	MA5219	VA-144	MA5528	VA-182	MA5785	VA-329
HP5895	VO-101	MA3590	VA-65	MA5227	VA-91	MA5534	VA-206	MA5786	VA-309
HP6127	VO-109	MA3593	VA-413	MA5244	VA-153	MA5535	VA-174	MA5787	VA-351
HP6128	VO-104	MA4	VA-321	MA5248	VA-117	MA5538	VA-328	MA5788	VA-315
HP6135	VO-110	MA4278	VA-86	MA5249	VA-118	MA5539	VA-380	MA5789	VA-278
HP6296	VO-114	MA4342	VA-85	MA5257	VA-136	MA5546	VA-204	MA5792	VA-282
HP6311	VO-102	MA4343	VA-205	MA5258	VA-178	MA5553	VA-179	MA5793	VA-362
HP8154	VO-115	MA4343	VA-205	MA5265	VA-116	MA5554	VA-355	MA5794	VA-360
HP8161	VO-117	MA4361	VA-408	MA5266	VA-147	MA5555	VA-386	MA5796	VA-323
HP8165	VO-149	MA4372	VA-90	MA5267	VA-137	MA5556	VA-181	MA5798	VA-289
SERVICE PRO		MA4378	VA-70	MA5267	VA-138	MA5557	VA-330	MA5799	VA-234
AF3592	VA-66	MA4468	VA-84	MA5272	VA-410	MA5560	VA-180	MA5801	VA-374
AF4877	VA-89	MA4601	VA-414	MA5278	VA-159	MA5566	VA-197	MA5802	VA-368
CV10619C	VCA-1187	MA4622	VA-274	MA5279	VA-339	MA5567	VA-249	MA5804	VA-353
E10040	VO-114	MA4632	VA-88	MA5291	VA-122	MA5568	VA-186	MA5814	VA-317
E5399	VO-75	MA4645	VA-96	MA5301	VA-142	MA5569	VA-382	MA5816	VA-372
E5436	VO-76	MA4646	VA-158	MA5305	VA-146	MA5578	VA-195	MA5819	VA-258
E6135	VO-110	MA4648	VA-416	MA5314	VA-259	MA5582	VA-215	MA5820	VA-236
MA10003	VA-312	MA4650	VA-101	MA5315	VA-271	MA5583	VA-216	MA5822	VA-219
MA10004	VA-393	MA4669	VA-97	MA5315	VA-324	MA5584	VA-208	MA5823	VA-349
MA10005	VA-304	MA4675	VA-261	MA5323	VA-149	MA5585	VA-184	MA5824	VA-332
MA10006	VA-305	MA4680	VA-83	MA5324	VA-140	MA5587	VA-377	MA5825	VA-447
MA10007	VA-311	MA4682	VFAP-7912	MA5330	VA-78	MA5588	VA-188	MA5826	VA-318
MA10014	VA-344	MA4688	VA-207	MA5353	VA-150	MA5589	VA-359	MA5833	VA-240
MA10015	VA-308	MA4690	VA-102	MA5359	VA-151	MA5592	VA-198	MA5841	VA-246
MA10017	VA-303	MA4711	VA-340	MA5363	VA-191	MA5594	VA-269	MA5880	VA-263
MA10019	VA-307	MA4712	VA-404	MA5370	VA-190	MA5595	VA-187	MA5891	VA-375
MA10025	VA-301	MA4712	VFAP-7854	MA5372	VA-156	MA5596	VA-226	MA5907	VA-253
MA10178	VA-446	MA4715	VA-99	MA5373	VA-152	MA5601	VA-228	MA6052	VA-250
MA10187	VA-427	MA4717	VA-98	MA5376	VA-350	MA5602	VA-227	MA6056	VA-358
MA10188	VA-457	MA4720	VA-104	MA5378	VA-111	MA5603	VA-200	MA6061	VA-294
MA10190	VA-450	MA4722	VFAP-7892	MA5380	VA-394	MA5604	VA-217	MA6064	VA-384
MA10215	VA-424	MA4727	VA-105	MA5381	VA-347	MA5620	VA-337	MA6065	VA-383
MA10222	VA-419	MA4729	VA-379	MA5387	VA-172	MA5625	VA-248	MA6067	VFA-1641
MA10240	VA-392	MA4731	VA-108	MA5393	VA-399	MA5626	VA-365	MA6093	VA-313
MA10241	VA-331	MA4799	VA-103	MA5394	VA-345	MA5633	VA-222	MA6094	VA-268
MA10242	VA-440	MA4807	VA-370	MA5395	VA-193	MA5634	VA-213	MA6100	VA-366
MA10252	VA-444	MA4819	VA-107	MA5396	VA-154	MA5635	VA-229	MA6101	VA-385
MA10304	VA-434	MA4831	VFAP-7857	MA5396	VA-245	MA5638	VA-218	MA6102	VA-280
MA10325	VA-435	MA4832	VA-106	MA5397	VA-165	MA5642	VA-223	MA6105	VA-378
MA10392	VA-451	MA4838	VA-132	MA5398	VA-170	MA5645	VA-352	MA6109	VA-266
MA10394	VA-428	MA4839	VA-387	MA5400	VA-169	MA5645	VA-354	MA6114	VA-257
MA10411	VA-425	MA4848	VFAP-7859	MA5403	VA-192	MA5647	VA-201	MA6116	VA-273
MA10418	VA-437	MA4852	VFAP-917	MA5405	VA-155	MA5649	VA-214	MA6118	VA-283
MA10421	VA-430	MA4855	VA-338	MA5414	VA-164	MA5650	VA-209	MA6119	VA-275
MA10423	VA-438	MA4858	VFAP-1612	MA5418	VA-162	MA5651	VA-202	MA6120	VA-267

CAUTION: For general references only. Check catalog for correct filter application. Any use of this interchange to determine filter application is done at the installers risk.

PRECAUCION: Solamente para referencias generales. Revise el catálogo para la correcta aplicación del filtro. Cualquier uso de la referencia cruzada para determinar la aplicación del filtro es riesgo del instalador. ATTENTION : Seulement pour les références d'ordre général. Contrôler l'application correcte du filtre avec le catalogue. Toute utilisation de moyens afin de déterminer l'application d'un filtre est faite aux risques de l'installateur.

Cross Reference

Table da equivalencias da fabricantes

Code de renvoi au fabricant

MFR'S NUMBER	REPLACEMENT NUMBER	MFR'S NUMBER	REPLACEMENT NUMBER	MFR'S NUMBER	REPLACEMENT NUMBER	MFR'S NUMBER	REPLACEMENT NUMBER	MFR'S NUMBER	REPLACEMENT NUMBER
SERVICE PRO		MC16098	VCA-1094	MC36154C	VCA-1078C	M5230	VO-118	SHA116	VA-106
MA6124	VA-265	MC16108	VCA-1039	MC36156	VCA-1073	M5247	LC-8170	SHA118	VA-102
MA6130	VA-254	MC16203	VCA-1098	MC36157	VCA-1072	M5250	VO-150	SHA119	VA-103
MA6130	VA-255	MC25082	VCA-1001	MC36158	VCA-1071	M5251	LC-8445	SHA120	VFAP-7854
MA6139	VA-391	MC25245	VCA-1002	MC36174	VCA-1081	M5274	VO-67	SHA122	VA-98
MA6140	VA-284	MC25246	VCA-1021	MC36179	VCA-1075	M5276	VO-69	SHA125	VFAP-7857
MA6143	VA-443	MC25480	VCA-1029	MC38188	VCA-1042	M5280	VO-74	SHA126	VA-110
MA6144	VA-319	MC25490	VCA-1030	MC38222	VCA-1067	M5288	VO-108	SHA127	VA-109
MA6145	VA-296	MC25571	VCA-1101	MC45383	VCA-1026	M5308	VO-71	SHA128	VFAP-7892
MA6146	VA-295	MC25572	VCA-1102	MC45459	VCA-1013	M5309	VO-73	SHA129	VA-113
MA6149	VA-288	MC25685	VCA-1104	MC45508	VCA-1104	M5313	VO-65	SHA131	VA-89
MA6151	VA-287	MC25764	VCA-1041	MC45527	VCA-1074	M5315	VO-66	SHA132	VA-114
MA6152	VA-296	MC25832	VCA-1106	MC45621	VCA-1172	M5316	VO-127	SHA133	VFAP-7859
MA6153	VA-291	MC25836	VCA-1075	MC45654	VCA-1043	M5317	VO-86	SHA134	VA-92
MA6163	VA-285	MC25840	VCA-1158	MC45662	VCA-1066	M5335	VO-64	SHA135	VA-112
MA6165	VA-286	MC25853	VCA-1109	MC45844	VCA-1153	M5399	VO-75	SHA136	VA-94
MA6167	VA-293	MC25858	VCA-1064	MC45871	VCA-1038	M5401	VO-93	SHA137	VA-93
MA6168	VA-290	MC25863	VCA-1110	M1A	VO-1	M5436	VO-76	SHA140	VFAP-1612
MA6169	VA-327	MC25864	VCA-1034	M10001	VO-149	M5438	VO-119	SHA141	VFAP-7908
MA6171	VA-292	MC25869	VCA-1069	M10002	VO-131	M5465	VO-82	SHA143	VA-135
MA6183	VA-310	MC25870	VCA-1044	M10023	VO-133	M5476	VO-78	SHA144	VA-260
MA6184	VA-473	MC25874	VCA-1113	M10040	VO-114	M5505	VO-80	SHA145	VFAP-1643
MA6197	VA-297	MC25875	VCA-1114	M10185	VO-25	M5511	VO-128	SHA146	VA-91
MA6199	VA-298	MC25876	VCA-1049	M10231	VO-132	M5515	VO-81	SHA147	VFAP-917
MA6200	VA-300	MC25877	VCA-1052	M10232	VO-142	M5515A	VO-81	SHA148	VA-117
MA6201	VA-299	MC25878	VCA-1054	M10233	VO-153	M5526	VO-81	SHA150	VFA-1641
MA6271	VA-429	MC26073	VCA-1057	M10239	VO-141	M5545	VO-150	SHA151	VA-320
MA6272	VA-306	MC26087	VCA-1116	M10259	VO-164	M5564	VO-112	SHA152	VA-259
MA6273	VA-426	MC26089	VCA-1117	M10260	VO-117	M5579	VO-94	SHA153	VA-116
MA6280	VA-302	MC26155	VCA-1118	M10306	VO-151	M5581	VO-85	SHA154	VA-118
MA6306	VA-237	MC26175	VCA-1177	M10355	VO-124	M5598	VO-92	SHA155	VA-412
MA6308	VA-221	MC26176	VCA-1077	M10383	VO-166	M5607	VO-91	SHA156	VA-410
MA6309	VA-220	MC26185	VCA-1120	M10387	VO-115	M5608	VO-84	SHA157	VA-122
MA6312	VA-357	MC26205	VCA-1080	M10390	VO-174	M5609	VO-87	SHA158	VA-120
MA6313	VA-225	MC35402	VCA-1122	M10430	VO-167	M5610	VO-90	SHA159	VA-140
MA6314	VA-264	MC35413	VCA-1022K	M10432	VO-170	M5646	VO-129	SHA160	VA-78
MA6318	VA-316	MC35425	VCA-1060	M10435	VO-165	M5690	VO-130	SHA161	VA-149
MA67	VA-402	MC35426	VCA-1024	M10479	VO-106	M5692	VO-97	SHA162	VA-111
MA7039	VA-157	MC35448	VCA-1022	M10592	VO-173	M5702	VO-96	SHA163	VA-129
MA7492	VA-314	MC35473	VCA-1123	M111	VO-16	M5830	VO-111	SHA164	VA-137
MA7765	VA-341	MC35479	VCA-1014	M193	VO-19	M5839	VO-98	SHA165	VA-150
MA91	VA-2	MC35484	VCA-1124	M195	VO-118	M5843	VO-138	SHA166	VA-124
MA92	VA-403	MC35491	VCA-1028	M2222	VO-88	M5848	VO-99	SHA167	VA-138
MC10008	VCA-1097	MC35494	VCA-1168	M241	VO-25	M5895	VO-101	SHA168	VA-114
MC10011	VCA-1174	MC35498	VCA-1125	M2500	VO-88	M5898	VO-101	SHA169	VA-146
MC10020	VCA-1082	MC35504C	VCA-1126	M252	VO-15	M5909	VO-140	SHA170	VA-151
MC10022C	VCA-1183	MC35518	VCA-1129	M2821A	VO-40	M6127	VO-109	SHA171	VA-154
MC10191	VCA-1184	MC35519	VCA-1063	M288	VO-46	M6128	VO-104	SHA172	VA-165
MC10257	VCA-1193	MC35526	VCA-1131	M291	VO-27	M6135	VO-110	SHA173	VFAP-7893
MC10303	VCA-1171	MC35530	VCA-1068	M33	VO-108	M6160	VO-121	SHA174	VA-136
MC10305	VCA-1176	MC35586	VCA-1135	M4006	VO-58	M6161	VO-122	SHA175	VA-156
MC10386	VCA-1173	MC35643	VCA-1070	M4011	VO-55	M6162	VO-116	SHA176	VA-152
MC10434	VCA-1178	MC35644	VCA-1037	M4457	VO-25	M6291	VO-123	SHA177	VA-193
MC10482	VCA-1181	MC35660	VCA-1051	M4459A	VO-106	M6311	VO-102	SHA178	VA-170
MC10490	VCA-1190	MC35661	VCA-1035	M4460A	VO-106	M81	VO-95	SHA179	VA-155
MC10491	VCA-1185	MC35667	VCA-1031	M4461	VO-106	M8113	VO-77	SHA180	VA-162
MC10573	VCA-1191	MC35668	VCA-1022	M4476	VO-40	M85	VO-37	SHA181	VA-167
MC10590	VCA-1186	MC35674	VCA-1138	M4477	VO-147	M8812	LC-834	SHA182	VA-144
MC10622	VCA-2035	MC35676	VCA-1065	M4484	VO-60	SPFG872	VG-32	SHA183	VA-178
MC10672	VCA-1181	MC35677	VCA-2033	M4619	VO-35	SPGF1481	VG-14	SHA184	VA-164
MC15388	VCA-1003	MC35856	VCA-1050	M4620	VO-106	SPGF1578	VG-33	SHA185	VA-166
MC15389	VCA-1008	MC35860	VCA-1155	M4622	VO-106	SPGF1580	VG-30	SHA186	VA-163
MC15439	VCA-1012	MC35861	VCA-1144	M4631	VO-56	SPGF800	VG-16	SHA187	VA-161
MC15471	VCA-1164	MC35865	VCA-1047	M4651	VO-88	SHELL (NEW)		SHA188	VA-160
MC15506	VCA-1160	MC35872	VCA-1145	M4656	VO-70	SHA10	VA-69	SHA189	VA-157
MC15510	VCA-1162	MC35898	VCA-1146	M4670	VO-95	SHA109	VA-97	SHA19	VA-86
MC15599	VCA-1170	MC36067	VCA-1062	M4757	VO-62	SHA110	VA-416	SHA190	VA-196
MC15659	VCA-1089	MC36080	VCA-1061	M4758	LC-833	SHA111	VA-101	SHA191	VA-171
MC15850	VCA-1048	MC36099	VCA-1059	M4798	VO-144	SHA113	VA-107	SHA192	VA-270
MC15862	VCA-1053	MC36115	VCA-1055	M4872	VO-63	SHA114	VA-104	SHA193	VA-183
MC16079	VCA-1093	MC36154	VCA-1078	M49	VO-65	SHA115	VA-99	SHA194	VA-192

CAUTION: For general references only. Check catalog for correct filter application. Any use of this interchange to determine filter application is done at the installers risk.

PRECAUCION: Solamente para referencias generales. Revise el catálogo para la correcta aplicación del filtro. Cualquier uso de la referencia cruzada para determinar la aplicación del filtro es riesgo del instalador. ATTENTION : Seulement pour les références d'ordre général. Contrôler l'application correcte du filtre avec le catalogue. Toute utilisation de moyens afin de déterminer l'application d'un filtre est faite aux risques de l'installateur.

Cross Reference

Table da equivalencias da fabricantes

Code de renvoi au fabricant

MFR'S NUMBER	REPLACEMENT NUMBER	MFR'S NUMBER	REPLACEMENT NUMBER	MFR'S NUMBER	REPLACEMENT NUMBER	MFR'S NUMBER	REPLACEMENT NUMBER	MFR'S NUMBER	REPLACEMENT NUMBER
SHELL (NEW)		SH55	VO-86	CAF1818P	VCA-1066	CAF7715	VCA-1150	SA10330	VA-349
SHA26	VA-2	SH56	VO-95	CAF1820P	VCA-1047	CAF7722	VCA-1127	SA10343	VA-234
SHA27	VA-403	SH57	VO-81	CAF1821P	VCA-1113	CAF7742	VCA-1165	SA10344	VA-252
SHA38	VA-402	SH58	VO-95	CAF1823B	VCA-1101	CAF7749	VCA-1168	SA10346	VA-238
SHA46	VA-40	SH59	VO-80	CAF1825P	VCA-1138	CAF7757	VCA-1164	SA10347	VA-289
SHA48	VA-44	STP		CAF1829P	VCA-1159	CAF7759	VCA-1131	SA10348	VA-258
SHA49	VA-38	CAF1700	VCA-1157	CAF1830P	VCA-1146	CAF7767	VCA-1126	SA10349	VA-233
SHA65	VA-65	CAF1702	VCA-1026	CAF1832P	VCA-1155	CAF7796	VCA-1124	SA10359	VA-237
SHA67	VA-66	CAF1703	VCA-1001	CAF1834P	VCA-1089	CAF7799	VCA-1133	SA10418	VA-326
SHA68	VA-413	CAF1704	VCA-1021	CAF1835P	VCA-1054	CAF90123P	VCA-1176	SA10464	VA-323
SHA71	VA-85	CAF1706	VCA-1002	CAF1839P	VCA-1046	CAF90131P	VCA-1193	SA10465	VA-255
SHA72	VA-70	CAF1707	VCA-1003	CAF1840C	VCA-1108	CAF90139P	VCA-1181	SA10466	VA-219
SHA73	VA-269	CAF1708	VCA-1167	CAF1840C	VCA-1158	CAF90165P	VCA-1190	SA10467	VA-221
SHA77	VA-205	CAF1713	VCA-1017	CAF1844P	VCA-1104	CAF90167P	VCA-2043	SA10468	VA-220
SHA78	VA-78	CAF1716	VCA-1161	CAF1845P	VCA-1069	LAF2959	VA-381	SA10470	VA-235
SHA79	VA-90	CAF1717	VCA-1123	CAF1846P	VCA-1051	LFP805	VO-136	SA10484	VA-448
SHA80	VA-88	CAF1720	VCA-1060	CAF1847P	VCA-1142	PH48R	VO-152	SA10488	VA-241
SHA82	VA-84	CAF1721	VCA-1162	CAF1848P	VCA-1038	P2923	VO-119	SA10490	VA-343
SHA83	VA-83	CAF1722	VCA-1127	CAF1849P	VCA-1034	P3968	VO-137	SA10494	VA-360
SHA85	VA-96	CAF1726	VCA-1122	CAF1850P	VCA-1049	P3972	VO-130	SA10495	VA-362
SHA86	VA-408	CAF1730	VCA-1039	CAF1851P	VCA-1110	P3987	VO-139	SA10497	VA-278
SHA87	VA-108	CAF1739	VCA-1040	CAF1852P	VCA-1052	P907	VO-138	SA10500	VA-315
SHA88	VA-105	CAF1742	VCA-1022	CAF1855P	VCA-1144	P961	VO-94	SA10522	VA-313
SHA9	VA-321	CAF1742K	VCA-1022K	CAF1857P	VCA-1194	P975	VO-120	SA10539	VA-240
SH1	VO-1	CAF1743	VCA-1008	CAF1861P	VCA-1036	P983	VO-140	SA10540	VA-372
SH16	VO-108	CAF1745	VCA-1125	CAF1862P	VCA-1050	SA10013	VA-202	SA10542	VA-282
SH161	VO-84	CAF1747	VCA-1160	CAF1863P	VCA-1114	SA10014	VA-200	SA10543	VA-379
SH164	VO-90	CAF1749	VCA-1010	CAF1864P	VCA-1064	SA10015	VA-210	SA10544	VA-332
SH167	VO-88	CAF1751	VCA-1042	CAF1865P	VCA-1053	SA10022	VA-337	SA10551	VA-351
SH18	VO-65	CAF1754	VCA-1029	CAF1866C	VCA-1153	SA10064	VA-377	SA10566	VA-364
SH20	VO-95	CAF1755	VCA-1020	CAF1867P	VCA-1062	SA10071	VA-382	SA10578	VA-357
SH23	VO-108	CAF1756	VCA-1163	CAF1868P	VCA-1059	SA10083	VA-228	SA10591	VA-375
SH26	VO-16	CAF1758	VCA-1012	CAF1869P	VCA-1055	SA10084	VA-227	SA10616	VA-246
SH27	VO-55	CAF1762	VCA-1030	CAF1870P	VCA-1109	SA10085	VA-226	SA10626	VA-263
SH28	VO-118	CAF1764	VCA-1028	CAF1872C	VCA-1078C	SA10088	VA-201	SA10633	VA-368
SH29	VO-25	CAF1765	VCA-1037	CAF1872P	VCA-1078	SA10092	VA-216	SA10650	VA-250
SH32	VO-37	CAF1766	VCA-1014	CAF1873P	VCA-1061	SA10093	VA-217	SA10656	VA-383
SH33	VO-35	CAF1767	VCA-1106	CAF1874P	VCA-1116	SA10094	VA-215	SA10661	VA-358
SH35	VO-95	CAF1768	VCA-1058	CAF1875P	VCA-1171	SA10110	VA-225	SA10662	VA-371
SH36	VO-88	CAF1770	VCA-1013	CAF1876P	VCA-1115	SA10115	VA-236	SA10675	VA-373
SH37	VO-46	CAF1771	VCA-1024	CAF1878P	VCA-1094	SA10118	VA-229	SA10676	VA-317
SH38	VO-56	CAF1774	VCA-1067	CAF1879P	VCA-1076	SA10159	VA-251	SA10677	VA-309
SH39	VO-63	CAF1779	VCA-1043	CAF1880P	VCA-1072	SA10161	VA-218	SA10680	VA-384
SH41	VO-58	CAF1781	VCA-1063	CAF1882P	VCA-1147	SA10163	VA-248	SA10685	VA-254
SH42	VO-118	CAF1782	VCA-1129	CAF1883P	VCA-1117	SA10165	VA-212	SA10690	VA-280
SH43	VO-108	CAF1789	VCA-1056	CAF1884P	VCA-1057	SA10169	VA-209	SA10692	VA-388
SH44	VO-67	CAF1792	VCA-1068	CAF1885P	VCA-1118	SA10170	VA-249	SA10693	VA-316
SH45	VO-65	CAF1795	VCA-1156	CAF1886P	VCA-1093	SA10171	VA-214	SA10694	VA-447
SH46	VO-73	CAF1796	VCA-1124	CAF1887P	VCA-1071	SA10173	VA-222	SA10699	VA-268
SH47	VO-64	CAF1797	VCA-1065	CAF1890P	VCA-1073	SA10190	VA-231	SA10720	VA-366
SH48	VO-106	CAF1800C	VCA-1135	CAF1891P	VCA-1098	SA10191	VA-243	SA10741	VA-257
SH49	VO-75	CAF1801	VCA-1139	CAF1897C	VCA-1080	SA10192	VA-213	SA10781	VA-253
SH50	VO-66	CAF1802P	VCA-1070	CAF1898P	VCA-1077	SA10193	VA-340	SA10785	VA-354
SH502	VO-15	CAF1803C	VCA-1096	CAF1899P	VCA-1177	SA10217	VA-329	SA10798	VA-378
SH504	VO-95	CAF1803P	VCA-1096	CAF1900P	VCA-1081	SA10228	VA-232	SA10802	VA-294
SH51	VO-76	CAF1804P	VCA-1048	CAF1903P	VCA-1082	SA10233	VA-242	SA10834	VA-267
SH516	VO-27	CAF1805C	VCA-2033	CAF1904P	VCA-1184	SA10234	VA-244	SA10839	VA-385
SH517	VO-19	CAF1806P	VCA-1170	CAF1907P	VCA-1175	SA10236	VA-204	SA10867	VA-296
SH518	VO-15	CAF1807P	VCA-1102	CAF1908P	VCA-1174	SA10242	VA-224	SA10881	VA-265
SH52	LC-8170	CAF1808P	VCA-1145	CAF1911P	VCA-1097	SA10253	VA-314	SA10885	VA-275
SH520	VO-106	CAF1809P	VCA-1134	CAF1914P	VCA-1173	SA10254	VA-356	SA10888	VA-266
SH524	VO-25	CAF1810C	VCA-1103	CAF1921P	VCA-1179	SA10255	VA-386	SA10889	VA-283
SH525	VO-40	CAF1810P	VCA-1103	CAF1925P	VCA-1186	SA10256	VA-318	SA10910	VA-437
SH528	VO-60	CAF1811P	VCA-1172	CAF1941P	VCA-1178	SA10257	VA-353	SA10957	VA-273
SH529	VO-106	CAF1812C	VCA-1074	CAF1945P	VCA-1189	SA10261	VA-264	SA10989	VA-296
SH53	VO-150	CAF1812P	VCA-1169	CAF1947P	VCA-1191	SA10262	VA-223	SA10990	VA-285
SH531	VO-106	CAF1813P	VCA-1041	CAF1949P	VCA-1188	SA10270	VA-239	SA10994	VA-443
SH533	VO-15	CAF1814P	VCA-1035	CAF1953P	VCA-1185	SA10271	VA-230	SA10996	VA-445
SH534	VO-106	CAF1815P	VCA-1044	CAF1957C	VCA-1195	SA10286	VA-374	SA10997	VA-284
SH538	VO-106	CAF1816P	VCA-1031	CAF1957C	VCA-1120	SA10324	VA-367	SA10999	VA-391
SH54	VO-69	CAF1817P	VCA-1075	CAF7702	VCA-1166	SA10328	VA-365	SA11010	VA-390

CAUTION: For general references only. Check catalog for correct filter application. Any use of this interchange to determine filter application is done at the installers risk.

PRECAUCION: Solamente para referencias generales. Revise el catálogo para la correcta aplicación del filtro. Cualquier uso de la referencia cruzada para determinar la aplicación del filtro es riesgo del instalador. ATTENTION : Seulement pour les références d'ordre général. Contrôler l'application correcte du filtre avec le catalogue. Toute utilisation de moyens afin de déterminer l'application d'un filtre est faite aux risques de l'installateur.

Cross Reference

Table da equivalencias da fabricantes

Code de renvoi au fabricant

MFR'S NUMBER	REPLACEMENT NUMBER	MFR'S NUMBER	REPLACEMENT NUMBER	MFR'S NUMBER	REPLACEMENT NUMBER	MFR'S NUMBER	REPLACEMENT NUMBER	MFR'S NUMBER	REPLACEMENT NUMBER
STP		SA326	VA-2	SA7819	VA-401	SA9379	VA-279	S11242	VO-133
SA11011	VA-396	SA327	VA-403	SA7819	VA-96	SA9392	VA-193	S11246	VO-151
SA11033	VA-295	SA3492	VA-45	SA7983	VA-345	SA9400	VA-167	S11252	VO-121
SA11042	VA-291	SA3501	VA-411	SA8014	VFAP-7912	SA9401	VA-160	S11462	VO-123
SA11048	VA-290	SA3559	VA-40	SA8037	VA-320	SA9409	VA-325	S11665	VO-114
SA11049	VA-327	SA3588	VA-38	SA8038	VA-92	SA9435	VA-199	S11784	VO-117
SA11053A	VA-334	SA3647	VA-44	SA8039	VA-94	SA9441	VA-172	S11790	VO-153
SA11062	VA-446	SA3660	VA-69	SA8040	VFAP-7908	SA9459	VA-335	S11794	VO-142
SA11109	VA-310	SA3901	VA-90	SA8069	VA-144	SA9471	VA-342	S11816	VO-174
SA11113	VA-292	SA3902	VA-85	SA8121	VA-147	SA9482	VA-171	S11934	VO-167
SA11114	VA-288	SA3914	VFAP-917	SA8127	VA-412	SA9492	VA-176	S11955	VO-115
SA11118	VA-444	SA3916	VA-65	SA8133	VA-117	SA9493	VA-196	S12060	VO-160
SA11121	VA-297	SA4048	VA-245	SA8141	VFA-1641	SA9501	VA-399	S12246	VO-173
SA11170	VA-287	SA4309	VA-86	SA8142	VFAP-1643	SA9502	VA-361	S16	VO-95
SA11206	VA-300	SA4576	VA-389	SA8162	VA-131	SA9516	VA-174	S16	VO-95
SA11215	VA-301	SA4939	VA-408	SA8188	VA-148	SA9525	VA-247	S2	VO-88
SA11222	VA-426	SA5056	VA-205	SA8205	VA-129	SA9555	VA-185	S200PL	VO-134
SA11227	VA-299	SA5056B	VA-205	SA8208	VA-153	SA9563	VA-322	S25	VO-108
SA11250	VA-473	SA5057	VA-413	SA8220	VA-341	SA9564	VA-183	S2808	VO-106
SA11251	VA-308	SA5058	VA-66	SA8221	VA-91	SA9565	VA-328	S2827	VO-25
SA11257	VA-293	SA5125	VA-414	SA8243	VA-260	SA9589	VA-177	S2869	VO-106
SA11258	VA-307	SA5198	VA-286	SA8269	VA-410	SA9600	VA-184	S2870A	VO-15
SA11259	VA-302	SA5350	VFAP-7865	SA8295	VA-347	SA9603	VA-175	S2878	VO-175
SA11298	VA-331	SA5466	VFAP-7892	SA8475	VA-118	SA9636	VA-352	S2903	VO-52
SA11305	VA-450	SA5595	VFAP-7893	SA8547	VA-136	SA9662	VA-189	S2995	VO-86
SA11413	VA-393	SA5876	VA-380	SA8548	VA-178	SA9669	VA-194	S3387A	VO-16
SA11420	VA-392	SA6366	VA-70	SA8601	VA-397	SA9681	VA-206	S3506	VO-58
SA11422	VA-423	SA6395	VA-84	SA8602	VA-138	SA9683	VA-195	S3531	VO-27
SA11426	VA-344	SA6479	VA-78	SA8606	VA-116	SA9687	VA-182	S3569	VO-15
SA11431	VA-303	SA6555	VA-88	SA8612	VA-339	SA9689	VA-400	S3600	VO-118
SA11439	VA-442	SA6626	VA-269	SA8613	VA-159	SA9708	VA-363	S3614	VO-25
SA11450	VA-312	SA6807	VA-83	SA8625	VA-208	SA9711	VA-274	S3675	VO-108
SA11453	VA-435	SA6821	VA-158	SA8636	VA-146	SA9762	VA-179	S3766	VO-46
SA11456	VA-298	SA6828	VA-416	SA8713	VA-350	SA9778	VA-181	S3786	VO-63
SA11469	VA-427	SA6849	VA-370	SA8720	VA-394	SA9798	VA-359	S3950	VO-19
SA11476	VA-304	SA6850	VA-97	SA8747	VA-156	SA9806	VA-355	S3970	VO-37
SA11477	VA-305	SA6900	VA-261	SA8755	VA-259	SA9838	VA-180	S3976	VO-64
SA11480	VA-306	SA7094	VA-101	SA8755HD	VA-271	SA9875	VA-211	S3980	VO-55
SA11482	VA-429	SA7142	VA-99	SA8760	VA-270	SA9894	VA-319	S3985	VO-35
SA11494	VA-457	SA7167	VA-98	SA8766	VA-152	SA9895	VA-186	S4967	VO-40
SA11500	VA-311	SA7174	VA-103	SA8805	VA-137	SA9898	VA-207	S5	VO-56
SA11501	VA-424	SA7246	VA-395	SA8817	VA-164	SA9900	VA-187	S5	VO-56
SA11541	VA-490	SA7344	VA-104	SA8911	VA-165	SA9902	VA-188	S5320	LC-834
SA11712	VA-419	SA7351	VA-102	SA8922	VA-190	SA9912	VA-330	S5618	VO-86
SA11858	VA-438	SA7365	VA-404	SA8925	VA-122	SA9944	VA-197	S5618	VO-86
SA11876	VA-453	SA7365	VFAP-7854	SA8956	VA-142	SA9953	VA-336	S6607	VO-106
SA11895	VA-440	SA7414	VA-107	SA8960	VA-324	SA9969	VA-203	S6847	VO-70
SA11942	VA-417	SA7417	VFAP-7859	SA8969	VA-140	SA9997	VA-198	S6848	VO-62
SA11948	VA-428	SA7420	VA-113	SA8970	VA-166	S10060	VO-200	S6941	VO-135
SA11959	VA-425	SA7421	VA-108	SA90113	VA-434	S10060	VO-88	S7073	LC-833
SA11960	VA-460	SA7426	VA-106	SA90117	VA-449	S10066	VO-111	S7317	VO-106
SA11964	VA-485	SA7431	VA-124	SA90120	VA-451	S10075	VO-91	S7328	VO-95
SA11970	VA-452	SA7432	VA-112	SA90140	VA-430	S10158	VO-87	S7732	VO-144
SA12050	VA-464	SA7438	VA-93	SA90141	VA-432	S10160	VO-92	S8A	VO-1
SA12051	VA-454	SA7440	VA-105	SA90142	VA-431	S10246	VO-98	S8081	LC-8170
SA12057	VA-465	SA7597	VA-109	SA90143	VA-418	S10267	VO-170	S8087	LC-8445
SA12061	VA-456	SA7598	VA-110	SA90155	VA-466	S10295	VO-96	S8158	VO-150
SA12064	VA-468	SA7600	VA-338	SA9053	VA-155	S10323	VO-129	S8212	VO-60
SA12065	VA-458	SA7605	VA-128	SA9054	VA-154	S10358	VO-102	S8213	VO-74
SA12066	VA-455	SA7614	VA-120	SA9055	VA-149	S10415	VO-97	S8278	VO-127
SA12085	VA-459	SA7620	VA-132	SA9073	VA-333	S10515	VO-99	S8316	VO-118
SA12091	VA-461	SA7626	VA-125	SA9113	VA-150	S10530	VO-112	S8481	VO-69
SA12112	VA-471	SA7628	VFAP-7857	SA9115	VA-191	S10590	VO-201	S8530	VO-71
SA12166	VA-467	SA7630	VA-387	SA9269	VA-169	S10590	VO-88	S8712	VO-66
SA12168	VA-470	SA7640	VA-111	SA9277	VA-346	S10590	VO-88	S8765	VO-67
SA12182	VA-462	SA7651	VA-157	SA9286	VA-151	S10600	VO-101	S8806	VO-73
SA12183	VA-463	SA7730	VA-89	SA9332	VA-162	S10855	VO-109	S8830	VO-124
SA12258	VA-469	SA7737	VFAP-1613	SA9345	VA-161	S10890	VO-104	S8873	VO-65
SA12260	VA-474	SA7738	VFAP-1612	SA9359	VA-170	S10955	VO-110	S8873	VO-65
SA160	VA-321	SA7764	VA-135	SA9360	VA-163	S10992	VO-141	S8994	VO-93
SA192	VA-402	SA7774	VA-114	SA9361	VA-192	S11007	VO-131	S90170	VO-172

CAUTION: For general references only. Check catalog for correct filter application. Any use of this interchange to determine filter application is done at the installers risk.

PRECAUCION: Solamente para referencias generales. Revise el catálogo para la correcta aplicación del filtro. Cualquier uso de la referencia cruzada para determinar la aplicación del filtro es riesgo del instalador. ATTENTION : Seulement pour les références d'ordre général. Contrôler l'application correcte du filtre avec le catalogue. Toute utilisation de moyens afin de déterminer l'application d'un filtre est faite aux risques de l'installateur.

Cross Reference

Table da equivalencias da fabricantes

Code de renvoi au fabricant

MFR'S NUMBER	REPLACEMENT NUMBER	MFR'S NUMBER	REPLACEMENT NUMBER	MFR'S NUMBER	REPLACEMENT NUMBER	MFR'S NUMBER	REPLACEMENT NUMBER	MFR'S NUMBER	REPLACEMENT NUMBER
STP		S8765XL	VO-67	15208-KA000	VO-106	1045	VA-155	1785	VA-192
S9018R	VO-76	S8873XL	VO-65	15208-KA010	VO-106	1050	VA-179	1790	VA-307
S9100	VO-75	S8994XL	VO-93	16546-AA020	VA-86	1055	VA-137	1795	VA-196
S9447	VO-78	S90170XL	VO-172	16546-AA030	VFAP-7908	1060	VA-116	1800	VA-117
S9461	VO-77	S9018RXL	VO-76	16546-AA050	VA-86	1065	VA-258	1805	VA-291
S9549	VO-81	S90186XL	VO-169	16546-AA070	VA-150	1070	VA-164	1810	VA-431
S9584	VO-82	S9100XL	VO-75	16546-AA07A	VA-150	1075	VA-290	1815	VA-184
S9641	VO-80	S9461XL	VO-77	16546-AA080	VA-86	1080	VA-321	1820	VFAP-7908
S9713	VO-116	S9549XL	VO-81	16546-AA090	VA-198	1085	VA-129	1825	VA-118
S985	VO-103	S9641XL	VO-80	16546-AA10A	VA-198	1090	VA-229	1830	VA-220
S9911	VO-85	S9713XL	VO-116	16546-AA12A	VA-198	1095	VA-232	1835	VA-252
S9955	VO-128	S9911XL	VO-85	16546-AA120	VA-198	1100	VA-160	1840	VA-454
S9972	VO-84	S9972XL	VO-84	16546-AA150	VA-498	1105	VA-264	1845	VA-275
S9999	VO-90	S9999XL	VO-90	16546-AA16A	VA-498	1110	VA-177	1850	VA-135
STP EXTEND LIFE OIL		STP MAX LIFE		16546-JB000	VA-171	1115	VA-111	2000	VA-265
S10060XL	VO-200	S10060ML	VO-200	24865-80100	VO-40	1250	VA-224	2005	VA-334
S10060XL	VO-88	S10075ML	VO-91	38087-2100	VO-106	1255	VA-149	2010	VA-300
S10066XL	VO-111	S10246ML	VO-98	42033-5400	VO-106	1260	VA-288	2015	VA-193
S10075XL	VO-91	S10295ML	VO-96	42033-5410	VO-106	1265	VA-260	2020	VA-235
S10158XL	VO-87	S10358ML	VO-102	42033-5500	VO-106	1270	VA-306	2025	VA-311
S10160XL	VO-92	S10590ML	VO-201	42033-7000	VO-25	1275	VA-215	2030	VA-208
S10246XL	VO-98	S10590ML	VO-88	42033-7100	VO-25	1280	VA-66	2035	VA-152
S10295XL	VO-96	S10600ML	VO-101	42033-7110	VO-15	1285	VA-241	2250	VA-302
S10323XL	VO-129	S10890ML	VO-104	72880-AG00A	VCA-1145	1290	VA-89	2255	VA-207
S10358XL	VO-102	S10955ML	VO-110	72880-AJ00A	VCA-1031	1295	VA-186	2500	VA-206
S10415XL	VO-97	S11665ML	VO-114	72880-AJ010	VCA-1110	1300	VA-216	2750	VA-86
S10515XL	VO-99	S16ML	VO-95	72880-AL00A	VCA-1031	1305	VA-140	2755	VA-105
S10590XL	VO-201	S2ML	VO-88	72880-FG000	VCA-1055	1310	VA-197	2760	VA-261
S10590XL	VO-88	S2808ML	VO-106	72880-FJ000	VCA-1055	1315	VA-404	2765	VA-312
S10600XL	VO-101	S3387AML	VO-16	72880-FL00A	VCA-2051	1320	VA-205	2770	VA-233
S10759XL	VO-132	S3506ML	VO-58	72880-FL500	VCA-2051	1320	VA-205	2775	VA-438
S10855XL	VO-109	S3600ML	VO-118	72880-SA000	VCA-1114	1325	VA-94	2780	VA-244
S10890XL	VO-104	S3614ML	VO-25	72880-XA00A	VCA-1014	1330	VA-223	2785	VA-301
S10955XL	VO-110	S3675ML	VO-108	88074-100	VO-15	1335	VA-70	2790	VA-238
S10992XL	VO-141	S3976ML	VO-64	88074-110	VO-15	1340	VA-182	2795	VA-97
S11007XL	VO-131	S3980ML	VO-55	SUPERTECH		1345	VA-162	3000	VA-198
S11060XL	VO-149	S4967ML	VO-40	ST10060	VO-200	1350	VA-114	3010	VA-271
S11242XL	VO-133	S6607ML	VO-106	ST10060	VO-88	1355	VA-322	3250	VA-163
S11473XL	VO-164	S8AML	VO-1	ST10246	VO-98	1360	VA-167	3255	VA-214
S11665XL	VO-114	S8765ML	VO-67	ST10358	VO-102	1500	VA-78	3260	VA-231
S11675XL	VO-165	S9018RML	VO-76	ST10575	VO-201	1505	VA-176	3265	VA-102
S11784XL	VO-117	S9100ML	VO-75	ST10575	VO-88	1510	VA-255	3270	VA-209
S11794XL	VO-142	S9911ML	VO-85	ST10575	VO-88	1515	VA-109	3275	VA-171
S11934XL	VO-167	S9972ML	VO-84	ST10955	VO-110	1520	VA-225	3280	VA-309
S11955XL	VO-115	SUBARU		ST16	VO-95	1525	VA-161	3285	VA-257
S12056XL	VO-168	G3010-SA100	VCA-1114	ST2	VO-88	1530	VA-296	3290	VA-440
S12060XL	VO-160	G3210-AE000	VCA-1145	ST3387	VO-16	1535	VA-200	3295	VA-125
S16XL	VO-95	G3210-AG000	VCA-1014	ST3506	VO-58	1540	VA-91	3305	VA-251
S2XL	VO-88	SOA25-0000	VO-15	ST3600	VO-118	1545	VA-65	3310	VA-273
S2808XL	VO-106	SOA25-0010	VO-15	ST3600	VO-118	1550	VFAP-7892	3315	VA-195
S2827XL	VO-25	SOA28-0000	VO-25	ST3614	VO-25	1555	VA-203	3320	VA-146
S2869XL	VO-106	SOA51-65100	VO-25	ST3980	VO-55	1560	VA-280	3325	VA-234
S2870AXL	VO-15	SOA51-65109	VO-106	ST4386	VO-40	1565	VA-308	3330	VA-401
S2878XL	VO-175	15208-AA000	VO-25	ST4967	VO-40	1570	VFAP-917	3330	VA-96
S3387AXL	VO-16	15208-AA001	VO-25	ST5	VO-56	1575	VA-269	3500	VA-274
S3506XL	VO-58	15208-AA020	VO-106	ST6607	VO-106	1580	VA-38	3505	VA-138
S3569XL	VO-15	15208-AA021	VO-106	ST6607	VO-106	1585	VA-101	3510	VA-226
S3600XL	VO-118	15208-AA022	VO-106	ST6607	VO-106	1590	VA-259	5005	VCA-1044
S3614XL	VO-25	15208-AA023	VO-106	ST8A	VO-1	1595	VA-2	5010	VCA-1073
S3675XL	VO-108	15208-AA024	VO-106	ST9018	VO-76	1600	VA-108	5015	VCA-1077
S3786XL	VO-63	15208-AA030	VO-106	ST9688	VO-106	1605	VA-169	5020	VCA-1168
S3980XL	VO-55	15208-AA031	VO-106	ST9972	VO-84	1610	VA-92	5025	VCA-1069
S4967XL	VO-40	15208-AA060	VO-106	1000	VA-287	1615	VA-295	5030	VCA-1097
S5XL	VO-56	15208-AA080	VO-106	1005	VA-156	1620	VA-181	5250	VCA-1081
S6607XL	VO-106	15208-AA09A	VO-106	1010	VA-104	1750	VA-202	5255	VCA-1118
S8AXL	VO-1	15208-AA100	VO-106	1015	VA-154	1755	VA-304	5260	VCA-1174
S8081XL	LC-8170	15208-AA12A	VO-106	1020	VA-90	1760	VA-292	5265	VCA-1049
S8278XL	VO-127	15208-AA130	VO-106	1025	VA-286	1765	VA-212	5270	VCA-1104
S8481XL	VO-103	15208-AA15A	VO-106	1030	VA-293	1770	VA-183	5275	VCA-1102
S8481XL	VO-69	15208-AA160	VO-106	1035	VA-180	1775	VA-221	5500	VCA-1075
S8712XL	VO-66	15208-AA170	VO-106	1040	VA-69	1780	VA-165	5505	VCA-1173

CAUTION: For general references only. Check catalog for correct filter application. Any use of this interchange to determine filter application is done at the installers risk.
 PRECAUCION: Solamente para referencias generales. Revise el catálogo para la correcta aplicación del filtro. Cualquier uso de la referencia cruzada para determinar la aplicación del filtro es riesgo del instalador. ATTENTION : Seulement pour les références d'ordre général. Contrôler l'application correcte du filtre avec le catalogue. Toute utilisation de moyens afin de déterminer l'application d'un filtre est faite aux risques de l'installateur.

Cross Reference

Table da equivalencias da fabricantes

Code de renvoi au fabricant

MFR'S NUMBER	REPLACEMENT NUMBER	MFR'S NUMBER	REPLACEMENT NUMBER	MFR'S NUMBER	REPLACEMENT NUMBER	MFR'S NUMBER	REPLACEMENT NUMBER	MFR'S NUMBER	REPLACEMENT NUMBER
SUPERTECH		16510-86CA0	VO-52	15601-13011	VO-40	17801-21050	VA-231	87139-52020	VCA-1031
5510	VCA-1002	16510-86CB1	VO-52	15601-13051	VO-25	17801-21060	VA-344	87139-52040	VCA-1031
5515	VCA-1003	16510-86Z00	VO-52	15601-20560-71	VO-1	17801-22020	VA-171	87139-76010	VCA-1014
5520	VCA-1080	16510-86Z01	VO-52	15601-22010	VO-15	17801-22050	VA-279	88508-01010	VCA-1037
5525	VCA-1022	16510-93J00	VO-40	15601-33010	VO-15	17801-25020	VA-273	88568-02020	VCA-1028
5530	VCA-1065	16511-85C00	VO-116	15601-33020	VO-15	17801-27010	VA-84	88568-37020	VCA-1110
5535	VCA-1184	16511-85E00	VO-116	15601-33021	VO-15	17801-28010	VA-170	88568-52010	VCA-1042
5540	VCA-1164	16516-84Z00	VO-98	15601-41010	VO-1	17801-28030	VA-214	88880-41010	VCA-1014
5545	VCA-1030	17801-16040	VA-414	15601-41030	VO-15	17801-31090	VA-195	88880-48020	VCA-1067
5750	VCA-1063	471Q-1012950	VO-106	15601-44010	VO-95	17801-31110	VA-289	90080-91034	VO-40
5755	VCA-1012	95681-54J00	VCA-1134	15601-44011	VO-95	17801-31120	VA-209	90080-91058	VO-40
5760	VCA-1061	95860-80J00	VCA-1117	15601-68010	VO-156	17801-31130	VA-273	90080-91210	VO-40
5765	VCA-1167	95860-82200	VCA-1041	15601-76004	VO-156	17801-31170	VA-445	90118-WB433	VO-106
6000	VCA-1047	95860-85Z00	VCA-1155	15601-76004-71	VO-156	17801-35020	VA-96	90915-CA001	VO-40
6005	VCA-1051	95860-85Z10	VCA-1155	15601-76007-71	VO-40	17801-37020	VA-257	90915-CA003	VO-40
6750	VCA-1068	95861-54J00	VCA-1134	15601-76008-71	VO-40	17801-37021	VA-257	90915-TA002	VO-40
6755	VCA-1082	95861-64J00	VCA-1109	15601-76009-71	VO-25	17801-38010	VA-309	90915-TB001	VO-25
6760	VCA-1038	95861-64J01	VCA-1109	15601-78101-71	VO-1	17801-38011	VA-309	90915-TD004	VO-1
6765	VCA-1041	95861-65D00	VCA-1160	15601-87104	VO-40	17801-38030	VA-234	90915-YZZA1	VO-40
6770	VCA-1034	95861-78J11	VCA-1030	15601-87202	VO-40	17801-38040	VA-445	90915-YZZA2	VO-40
7250	VCA-1037	TOYOTA		15601-87204	VO-40	17801-46060	VA-125	90915-YZZA3	VO-40
7255	VCA-1031	C0120-00013	VO-40	15601-87305	VO-19	17801-46080	VA-159	90915-YZZB3	VO-25
7260	VCA-1014	C0120-00015	VO-25	15601-87309	VO-19	17801-50010	VA-158	90915-YZZB5	VO-25
7265	VCA-1028	SU00300311	VO-106	15601-87705	VO-40	17801-50030	VA-339	90915-YZZB6	VO-25
7270	VCA-1042	SU00302112	VCA-1110	15615-U3160-71	VO-55	17801-50040	VA-146	90915-YZZB7	VO-25
7275	VCA-1067	SU300319	VA-171	17801-AD010	VA-209	17801-50060	VA-279	90915-YZZB9	VO-25
7500	VCA-1026	04152-B1010	VO-102	17801-AD020	VA-171	17801-55020	VA-96	90915-YZZC3	VO-40
7505	VCA-1135	04152-YZZA1	VO-84	17801-F0020	VA-500	17801-64010	VA-84	90915-YZZC4	VO-40
SUZUKI		04152-YZZA2	VO-87	17801-F0050	VA-273	17801-64020	VA-84	90915-YZZC7	VO-40
13780-52D00	VA-379	04152-YZZA3	VO-87	17801-YZZ01	VA-163	17801-64070	VA-84	90915-YZZD1	VO-25
13780-54G10	VA-377	04152-YZZA4	VO-96	17801-YZZ02	VA-214	17801-70020	VA-408	90915-YZZD2	VO-25
13780-65D10	VA-144	04152-YZZA5	VO-87	17801-YZZ03	VA-171	17801-70020-83	VA-408	90915-YZZD3	VO-25
13780-65J00	VA-374	04152-YZZA6	VO-102	17801-YZZ04	VA-248	17801-70040	VA-125	90915-YZZD3-DS	VO-25
13780-77E00	VA-144	04152-YZZG1	VO-84	17801-YZZ05	VA-231	17801-74020	VA-84	90915-YZZE1	VO-40
13780-78J00	VA-176	04152-0R010	VO-87	17801-YZZ06	VA-209	17801-74020-83	VA-84	90915-YZZE2	VO-147
13780-79K00	VA-385	04152-26010	VO-87	17801-YZZ10	VA-309	17801-74060	VA-102	90915-YZZF1	VO-40
13780-80J00	VA-368	04152-31060	VO-87	17801-YZZ11	VA-273	17801-77050	VA-500	90915-YZZF2	VO-40
13780-82200	VA-356	04152-31080	VO-87	17801-YZZ12	VA-257	32150-40840	VO-95	90915-YZZG1	VO-25
13780-82200	VA-105	04152-31090	VO-84	17801-0C040	VA-248	32150-40840-71	VO-95	90915-YZZM1	VO-175
13780-82210	VA-356	04152-37010	VO-102	17801-0D020	VA-171	32623-12620-71	VO-25	90915-03001	VO-40
13780-84Z00	VA-188	04152-38010	VO-87	17801-0D060	VA-231	32623-20570	VO-85	90915-03002	VO-25
13780-85Z00	VA-340	04152-38020	VO-96	17801-0H010	VA-163	32623-20570-71	VO-95	90915-03004	VO-40
13780-86Z00	VA-386	04152-40060	VO-121	17801-0H020	VA-163	40150-30370	VO-95	90915-03005	VO-25
15610-66G00	VO-52	04152-51010	VO-96	17801-0H050	VA-214	40150-30370-71	VO-95	90915-03006	VO-145
15610-86CB0	VO-52	08922-02001	VO-40	17801-0P010	VA-195	40150-30371	VO-95	90915-10001	VO-40
16510-56K00	VO-147	08922-02002	VO-40	17801-0P050	VA-273	80915-76010-71	VO-25	90915-10002	VO-40
16510-60B10	VO-25	08922-02004	VO-25	17801-0P051	VA-273	87139-F4010	VCA-2055	90915-10003	VO-40
16510-60B11	VO-25	08922-02005	VO-40	17801-0P100	VA-440	87139-YZZ03	VCA-1133	90915-10004	VO-40
16510-61A00	VO-25	08922-02010	VO-25	17801-0S010	VA-234	87139-YZZ05	VCA-1014	90915-10009	VO-175
16510-61A01	VO-40	08922-02011	VO-25	17801-0S020	VA-440	87139-YZZ08	VCA-1031	90915-10010	VO-40
16510-61A01	VO-40	11501-00530	VO-25	17801-0T030	VA-231	87139-YZZ09	VCA-1037	90915-20001	VO-25
16510-61A02	VO-40	11501-01100	VO-25	17801-0T040	VA-257	87139-YZZ16	VCA-1031	90915-20002	VO-25
16510-61A2MHL	VO-40	15600-54010	VO-145	17801-0V020	VA-309	87139-YZZ19	VCA-1014	90915-20003	VO-25
16510-61A20	VO-40	1560A-41010	VO-15	17801-0W010	VFAP-7859	87139-YZZ20	VCA-1031	90915-20004	VO-25
16510-61A21	VO-40	1560B-87305	VO-19	17801-02020	VA-84	87139-0D010	VCA-1031	90915-30002	VO-145
16510-61A30	VO-40	15600-01020	VO-40	17801-02030	VFAP-7892	87139-0D070	VCA-1031	91915-YZZD1	VO-25
16510-61A31	VO-40	15600-13051	VO-40	17801-03010	VA-102	87139-02090	VCA-1031	91915-YZZE1	VO-40
16510-73002	VO-25	15600-16010	VO-40	17801-07010	VA-146	87139-06030	VCA-1014	91915-YZZF2	VO-40
16510-73012	VO-25	15600-16020	VO-40	17801-07020	VA-125	87139-06040	VCA-1014	91915-10003	VO-40
16510-73013	VO-25	15600-25010	VO-95	17801-08010	VA-96	87139-06050	VCA-1031	TYC	
16510-78J00	VO-88	15600-33010	VO-15	17801-11080	VA-98	87139-07010	VCA-1031	800001P2	VCA-1012
16510-78J01	VO-88	15600-33020	VO-15	17801-15070	VFAP-7892	87139-07020	VCA-1031	800002P	VCA-1068
16510-82210	VO-106	15600-41010	VO-1	17801-16020	VA-414	87139-28010	VCA-1014	800003P	VCA-1063
16510-82211	VO-106	15600-44010	VO-95	17801-16020-83	VA-414	87139-28020	VCA-2035	800004C	VCA-1166
16510-82703	VO-40	15600-44011	VO-95	17801-16030	VA-84	87139-30010	VCA-1024	800005P	VCA-1014
16510-83010	VO-25	15600-61030	VO-1	17801-16040	VA-414	87139-30040	VCA-1031	800006P	VCA-1028
16510-83011	VO-25	15600-87320	VO-95	17801-20040	VA-163	87139-32010	VCA-1014	800008P	VCA-1014
16510-83012	VO-25	15600-96101	VO-25	17801-20050	VA-353	87139-33010	VCA-1133	800009P	VCA-1067
16510-84Z00	VO-16	15601-01010	VO-25	17801-21020	VA-399	87139-47010	VCA-1014	800010C	VCA-1162
16510-85FA0	VO-25	15601-10700-71	VO-1	17801-21030	VA-191	87139-48020	VCA-1067	800011P	VCA-1113
16510-85Z01	VO-16	15601-13010	VO-40	17801-21040	VA-251	87139-50030	VCA-1129	800012P	VCA-1031

CAUTION: For general references only. Check catalog for correct filter application. Any use of this interchange to determine filter application is done at the installers risk.

PRECAUCION: Solamente para referencias generales. Revise el catálogo para la correcta aplicación del filtro. Cualquier uso de la referencia cruzada para determinar la aplicación del filtro es riesgo del instalador. ATTENTION : Seulement pour les références d'ordre général. Contrôler l'application correcte du filtre avec le catalogue. Toute utilisation de moyens afin de déterminer l'application d'un filtre est faite aux risques de l'installateur.

Cross Reference

Table da equivalencias da fabricantes

Code de renvoi au fabricant

MFR'S NUMBER	REPLACEMENT NUMBER	MFR'S NUMBER	REPLACEMENT NUMBER	MFR'S NUMBER	REPLACEMENT NUMBER	MFR'S NUMBER	REPLACEMENT NUMBER	MFR'S NUMBER	REPLACEMENT NUMBER
TYC		800112P	VCA-1075	TRA-115-561	VO-64	06E-115-562B	VO-168	1K1-819-653A	VCA-1135
800013P	VCA-1040	800114C2	VCA-1096	TR3-115-561	VO-162	06E-115-562C	VO-92	1K1-819-653B	VCA-1135
800014P2	VCA-1041	800115C	VCA-1103	000-091-511A	VO-95	06E-115-562E	VO-168	168-115-561A	VO-15
800015C	VCA-1026	800117P	VCA-1038	021-115-351	VO-95	06F-133-843	VA-318	2D0-129-620	VA-380
800016P	VCA-1063	800118P2	VCA-1053	021-115-351A	VO-95	06F-133-843A	VA-318	2E0-129-620B	VA-349
800017P	VCA-1014	800119P2	VCA-1145	021-115-561	VO-144	06F-133-843B	VA-318	2E0-819-638	VCA-1142
800018P	VCA-1139	800120P2	VCA-1041	021-115-561A	VO-144	06H-115-403	VO-101	3C0-129-620A	VA-274
800019P	VCA-1002	800121C	VCA-1153	021-115-561B	VO-150	06H-115-561	VO-101	4A0-819-439A	VCA-1123
800022P	VCA-1102	800122P	VCA-1055	021-115-562	VO-144	06J-115-403C	VO-101	4B0-091-800	VCA-1123
800023P2	VCA-1046	800123P	VCA-1117	021-115-562A	VO-150	06J-115-403J	VO-101	4B0-819-439C	VCA-1124
800024P	VCA-1070	800125P	VCA-1061	021-115-562B	VO-150	06J-115-403M	VO-101	4F0-133-843	VA-329
800025P	VCA-1031	800126P	VCA-1034	021-116-351A	VO-95	06J-115-403Q	VO-101	4F0-133-843A	VA-329
800026P	VCA-1035	800131P	VCA-1116	027-133-843	VA-69	06J-115-561B	VO-101	5C0-129-620	VA-274
800027P	VCA-1146	800132P	VCA-1162	028-115-561B	VO-15	06K-115-466	VO-117	5C0-129-620B	VA-274
800028C2	VCA-1162	800133P	VCA-1144	028-115-561E	VO-15	06K-115-562	VO-117	5QM-129-620	VA-453
800029P	VCA-1047	800134P	VCA-1035	028-155-351	VO-15	06L-115-466	VO-117	5QM-129-620A	VA-453
800030P	VCA-1066	800135P	VCA-1051	03H-115-562	VO-133	06L-115-466C	VO-117	5C0-129-620	VA-453
800037P	VCA-1020	800136C	VCA-1131	03L-115-466	VO-132	06L-115-562	VO-117	5Q0-129-620B	VA-453
800038P	VCA-1037	800137C	VCA-1108	03L-115-562	VO-132	06L-115-561	VO-15	5Q0-129-620	VA-453
800039P	VCA-1065	800138P	VCA-1171	03N-115-562	VO-165	068-115-561A	VO-15	5Q0-819-644	VCA-1189
800040P2	VCA-1054	800139P	VCA-1104	030-115-561AA	VO-25	068-115-561B	VO-15	5Q0-819-644A	VCA-1189
800041P	VCA-1026	800140P	VCA-1031	030-115-561AB	VO-25	068-115-561C	VO-15	512-070-0509	VO-15
800042P	VCA-1014	800142P	VCA-1069	030-115-561D	VO-15	068-115-561F	VO-15	7B0-115-561A	VO-88
800043P	VCA-1014	800143P	VCA-1061	030-115-561E	VO-25	069-115-561	VO-15	7B0-129-620A	VA-286
800044P2	VCA-1048	800144P	VCA-1059	030-115-561F	VO-25	07C-115-562A	VO-94	7B0-819-644	VCA-1044
800045P	VCA-1122	800146P	VCA-1044	030-115-561K	VO-25	07K-129-620	VA-226	7L0-129-620	VA-204
800046P2	VCA-1089	800147P	VCA-1115	030-115-561P	VO-25	07Z-115-562	VO-139	7L0-129-620A	VA-204
800047P2	VCA-1167	800149C	VCA-1078C	030-115-561T	VO-25	070-115-561	VO-15	7P0-129-620A	VA-204
800048C2	VCA-1127	800151P	VCA-1118	034-115-561A	VO-15	071-115-562	VO-77	711-155-62B	VO-77
800049P	VCA-1024	800152P	VCA-1036	035-115-561	VO-15	071-115-562A	VO-77	711-156-2B	VO-77
800050P	VCA-1157	800156P	VCA-1076	037-115-561	VO-15	071-115-562B	VO-77	711-156-2C	VO-77
800051P	VCA-1047	800157P	VCA-1075	037-115-561A	VO-15	071-115-562C	VO-77	8E0-819-439	VCA-1124
800052C	VCA-1133	800158P	VCA-1062	037-115-561B	VO-15	074-115-561	VO-15	8K0-133-843	VA-448
800053C	VCA-1129	800159P	VCA-1071	037-115-561E	VO-15	074-115-562	VO-71	8K0-133-843D	VA-448
800057P	VCA-1106	800160P	VCA-1031	038-115-466	VO-71	075-115-561	VO-15	8K0-133-843E	VA-313
800059C	VCA-2033	800161P	VCA-1073	04E-115-561	VO-25	077-115-561E	VO-143	8K0-133-843M	VA-313
800060C	VCA-1165	800163P	VCA-1177	04E-115-561A	VO-25	077-115-561F	VO-119	8K0-819-439	VCA-1194
800061P2	VCA-1060	800165P	VCA-1077	04E-115-561B	VO-25	077-115-561G	VO-143	8R0-133-843C	VA-313
800062C	VCA-1168	800175P2	VCA-1093	04E-115-561C	VO-25	077-115-562	VO-150	8R0-133-843D	VA-313
800064P	VCA-1001	800176P2	VCA-1094	04E-115-561D	VO-25	077-155-561	VO-143	8R0-133-843E	VA-313
800065P	VCA-1008	800177P	VCA-1082	04E-115-561H	VO-25	077-155-561C	VO-143	8R0-133-843K	VA-313
800066P	VCA-1030	800178C	VCA-1080	045-115-466	VO-77	077-198-563	VO-119	892-018-08201	VO-15
800068P2	VCA-1160	800180P	VCA-1173	045-115-466A	VO-77	078-115-561B	VO-15	892-018-08900	VO-15
800069P2	VCA-1164	800181P	VCA-1184	045-115-466B	VO-77	078-115-561D	VO-15	911-901-107	VO-1
800072P2	VCA-1039	800182C	VCA-1183	045-115-561A	VO-15	078-115-561J	VO-93	VOLVO	
800074P	VCA-1017	800183P	VCA-1081	045-115-561B	VO-15	078-115-561K	VO-15	SA119530030	VO-106
800075P	VCA-1114	800184P	VCA-1176	045-115-561C	VO-15	079-115-561B	VO-94	SA821003720	VO-106
800077P2	VCA-1003	800185P	VCA-1175	046-133-843	VA-69	079-115-561F	VO-138	110200	VO-95
800079P	VCA-1013	800186C	VCA-1153	049-133-843	VA-69	079-115-561K	VO-138	11713228	VO-106
800080P	VCA-1002	800187P	VCA-1174	056-115-561	VO-15	079-198-405	VO-94	11713229	VO-106
800081P	VCA-1125	800189P	VCA-1051	056-115-561A	VO-15	079-198-405A	VO-94	11715829	VO-106
800082P	VCA-1029	800193P	VCA-1075	056-115-561B	VO-15	079-198-405B	VO-138	11715849	VO-106
800083C	VCA-1147	800194P	VCA-1188	056-115-561C	VO-15	079-198-405E	VO-138	1257492	VO-15
800084P	VCA-1050	800196P	VCA-1178	056-115-561G	VO-15	1H0-091-800	VCA-1166	12574927	VO-15
800085P2	VCA-1160	800197P	VCA-1186	057-115-561	VO-15	1H0-129-620	VA-124	12662862	VO-95
800086C	VCA-1031	800198P	VCA-1185	058-133-843	VA-157	1H0-819-644	VCA-1026	1275810	VO-66
800088P	VCA-1138	800199P	VCA-1179	059-115-561A	VO-15	1H0-819-644A	VCA-1026	12758108	VO-66
800089P2	VCA-1159	800201P	VCA-1189	059-115-561B	VO-15	1H0-819-644B	VCA-1026	12758116	VO-66
800091P	VCA-1044	800203P	VCA-1142	059-115-561C	VO-15	1JM-115-561BZ	VO-15	1318162	VO-15
800092P	VCA-1109	800205P	VCA-1190	06A-115-561	VO-15	1J0-129-620	VA-138	13281621	VO-15
800093P	VCA-1110	800213P	VCA-2035	06A-115-561B	VO-15	1J0-129-620A	VA-138	1343232	VCA-1161
800095P	VCA-1064	800214P	VCA-1181	06A-115-561D	VO-15	1J0-819-644	VCA-1166	13432323	VCA-1161
800096P2	VCA-1139	800216P	VCA-1191	06A-115-561E	VO-15	1J0-819-644A	VCA-1166	14523962	VO-106
800097P	VCA-1134	800217P	VCA-2055	06C-133-843	VA-325	1K0-129-620	VA-365	14525396	VO-106
800098P	VCA-1155	800218C	VCA-1195	06D-115-405	VO-85	1K0-129-620B	VA-365	14528387	VO-106
801011P	VCA-1052	800219P	VCA-1062	06D-115-466	VO-85	1K0-129-620D	VA-274	15155622	VO-64
801016P	VCA-1068	800221P2	VCA-1097	06D-115-562	VO-85	1K0-129-620E	VA-274	1526188	VO-15
801017P	VCA-1038	800222P	VCA-1064	06D-198-405	VO-85	1K0-129-620F	VA-274	15268956	VO-134
801019P	VCA-1170	VOLKSWAGEN		06E-115-466	VO-92	1K0-129-620G	VA-274	266286	VO-95
8010110C	VCA-1124	E51-207-00509	VO-15	06E-115-562	VO-92	1K0-129-620L	VA-274	2900776	VO-52
8010111P	VCA-1049	J90-915-20001	VO-25	06E-115-562A	VO-92	1K1-819-653	VCA-1135	30630752	VCA-1040

CAUTION: For general references only. Check catalog for correct filter application. Any use of this interchange to determine filter application is done at the installers risk.
 PRECAUCION: Solamente para referencias generales. Revise el catálogo para la correcta aplicación del filtro. Cualquier uso de la referencia cruzada para determinar la aplicación del filtro es riesgo del instalador. ATTENTION : Seulement pour les références d'ordre général. Contrôler l'application correcte du filtre avec le catalogue. Toute utilisation de moyens afin de déterminer l'application d'un filtre est faite aux risques de l'installateur.

Cross Reference

Table da equivalencias da fabricantes

Code de renvoi au fabricant

MFR'S NUMBER	REPLACEMENT NUMBER	MFR'S NUMBER	REPLACEMENT NUMBER	MFR'S NUMBER	REPLACEMENT NUMBER	MFR'S NUMBER	REPLACEMENT NUMBER	MFR'S NUMBER	REPLACEMENT NUMBER
VOLVO		9180596	VO-15	WAF2962	VA-200	WAF3955	VA-205	WAF4065	VA-257
30637444	VA-314	91805960	VO-15	WAF3054	VA-217	WAF3956	VA-179	WAF4067	VA-275
30650798	VO-111	9184130	VCA-1161	WAF3076	VA-360	WAF3957	VA-328	WAF4897	VA-253
30677533	VA-314	9186262	VFAP-7912	WAF3083	VA-225	WAF3958	VA-206	WAF4904	VA-284
30680293	VA-354	91862623	VFAP-7912	WAF3095	VA-219	WAF3959	VA-195	WAF5185	VA-265
30711616	VO-25	9186361	VA-350	WAF3096	VA-263	WAF3960	VA-359	WAF5186	VA-390
30731879	VO-25	91863613	VA-350	WAF3099	VA-388	WAF3961	VA-330	WAF5187	VA-283
30733893	VCA-1108	9192522	VCA-1161	WAF3128	VA-254	WAF3963	VA-386	WAF5189	VA-391
30745344	VA-315	9192523	VCA-1161	WAF3138	VA-255	WAF3965	VA-337	WAF5190	VA-273
30750013	VO-97	9204626	VCA-1040	WAF3139	VA-296	WAF3974	VA-207	WAF5191	VA-189
30757155	VA-314	92046267	VCA-1040	WAF3145	VA-285	WAF3975	VA-188	WAF5192	VA-319
30767022	VCA-1158	9445776	VFAP-7912	WAF3148	VA-327	WAF3977	VA-377	WAF5196	VA-291
30767024	VCA-1108	9454647	VA-333	WAF3171	VA-299	WAF3981	VA-340	WAF5197	VA-293
30777486	VO-25	991290710	VO-64	WAF3173	VA-280	WAF3982	VA-314	WAF5198	VA-286
30777487	VO-25	WARNER		WAF3174	VA-308	WAF3983	VA-251	WAF5199	VA-310
30780376	VCA-1172	G481	VG-14	WAF3178	VA-457	WAF3984	VA-198	WAF5200	VA-473
30792881	VA-288	G578	VG-33	WAF3184	VA-424	WAF3991	VA-379	WAF5201	VA-292
30850831	VA-90	G580	VG-30	WAF3195	VA-425	WAF3992	VA-202	WAF5205	VA-287
30852831	VA-90	G6367	VG-32	WAF3201	VA-468	WAF3993	VA-208	WAF5206	VA-300
30862730	VA-90	G800	VG-16	WAF3202	VA-471	WAF3994	VA-248	WAF5207	VA-301
30866266	VO-106	M1-113	VO-152	WAF3208	VA-459	WAF3996	VA-209	WAF5208	VA-297
30873414	VA-90	M1-210	VO-88	WAF3212	VA-467	WAF3997	VA-356	WAF5209	VA-426
3130907	VO-56	P985	VO-69	WAF3216	VA-183	WAF3998	VA-289	WAF5210	VA-307
3131412	VO-65	WAF10025	VA-502	WAF3217	VA-373	WAF3999	VA-226	WAF5211	VA-302
31366123	VCA-1108	WAF10031	VA-503	WAF3218	VA-364	WAF4	VA-321	WAF5212	VA-445
31366124	VCA-1158	WAF10032	VA-504	WAF3219	VA-316	WAF4000	VA-227	WAF5213	VA-392
31372212	VO-174	WAF1031	VA-69	WAF3220	VA-447	WAF4001	VA-228	WAF5216	VA-344
31390880	VCA-1108	WAF1032A	VA-205	WAF3226	VA-474	WAF4002	VA-210	WAF5217	VA-331
31449209	VCA-1158	WAF1042	VA-413	WAF3245	VA-184	WAF4003	VA-201	WAF5218	VA-393
31990880	VCA-1108	WAF1043	VA-66	WAF329	VA-403	WAF4004	VA-353	WAF5219	VA-303
3517857	VO-95	WAF1046	VA-70	WAF348	VA-2	WAF4006	VA-362	WAF5220	VA-312
35178573	VO-95	WAF1061	VA-88	WAF351	VA-84	WAF4007	VA-211	WAF5221	VA-427
3528093	VFAP-7912	WAF1096	VA-78	WAF355	VA-389	WAF4008	VA-212	WAF5222	VA-304
35280932	VFAP-7912	WAF1129	VA-269	WAF3588	VA-164	WAF4009	VA-374	WAF5223	VA-305
3827069	VO-16	WAF1236	VA-412	WAF3589	VA-185	WAF4010	VA-282	WAF5224	VA-311
3850559	VO-56	WAF1279	VA-91	WAF359	VA-408	WAF4011	VA-213	WAF5225	VA-460
3852412	VO-65	WAF1300	VA-92	WAF3590	VA-160	WAF4012	VA-229	WAF5230	VA-419
3854420	VO-1	WAF1301	VA-320	WAF3591	VA-363	WAF4014	VA-230	WAF5231	VA-437
418432	VO-95	WAF1518	VA-259	WAF3592	VA-237	WAF4015	VA-231	WAF5233	VA-434
4184321	VO-95	WAF1612	VFAP-1612	WAF3593	VA-325	WAF4017	VA-214	WAF5235	VA-438
419719	VO-95	WAF1613	VFAP-1613	WAF3594	VA-176	WAF4019	VA-242	WAF5239	VA-428
422994	VO-163	WAF1615	VA-94	WAF3595	VA-171	WAF4020	VA-343	WAF5240	VA-440
430143	VO-95	WAF1618	VA-120	WAF3598	VA-186	WAF4021	VA-240	WAF5244	VA-417
4301438	VO-95	WAF1624	VA-181	WAF3601	VA-249	WAF4022	VA-243	WAF5245	VA-418
6895003	VO-65	WAF1641	VFA-1641	WAF3604	VA-326	WAF4023	VA-244	WAF5246	VA-431
7410062	VO-106	WAF1643	VFAP-1643	WAF3605	VA-313	WAF4025	VA-258	WAF5248	VA-432
7413694	VO-95	WAF1658	VA-260	WAF3609	VA-446	WAF4026	VA-232	WAF5251	VA-334
7417534	VO-106	WAF1679	VA-142	WAF3612	VA-290	WAF4027	VA-252	WAF5252	VA-485
7699132	VA-288	WAF1688	VA-140	WAF3617	VA-423	WAF4028	VA-357	WAF5258	VA-455
7950975	VO-1	WAF1695	VA-162	WAF3618	VA-450	WAF4029	VA-238	WAF5259	VA-466
807180	VO-95	WAF1696	VA-149	WAF3621	VA-453	WAF4030	VA-233	WAF5260	VA-458
818511	VO-108	WAF1744	VA-322	WAF3626	VA-488	WAF4031	VA-234	WAF5263	VA-464
8185118	VO-108	WAF1754	VA-182	WAF372	VA-414	WAF4033	VA-235	WAF5264	VA-454
835440	VO-65	WAF178	VA-402	WAF3895	VA-194	WAF4034	VA-278	WAF5265	VA-465
8354409	VO-65	WAF1890	VA-241	WAF3896	VA-274	WAF4035	VA-372	WAF5266	VA-456
835779	VO-1	WAF2014	VA-161	WAF3897	VA-318	WAF4038	VA-332	WAF5271	VA-461
841750	VO-55	WAF2340	VA-175	WAF3898	VA-329	WAF4042	VA-236	WAF5273	VA-470
847741	VO-163	WAF2441	VA-247	WAF3899	VA-368	WAF4043	VA-351	WAF5277	VA-499
8477416	VO-163	WAF2442	VA-352	WAF3904	VA-180	WAF4044	VA-221	WAF5286	VA-500
861473	VO-40	WAF2548	VA-342	WAF3905	VA-199	WAF4045	VA-220	WAF5293	VA-498
8638600	VA-352	WAF2771	VA-197	WAF3906	VA-355	WAF4048	VA-245	WAF5296	VA-497
8642570	VO-85	WAF2780	VA-222	WAF3908	VA-367	WAF4049	VA-375	WAF5694	VA-371
8687389	VCA-1172	WAF2782	VA-382	WAF3910	VA-317	WAF4051	VA-294	WAF5696	VA-452
8692305	VO-85	WAF2785	VA-215	WAF3917	VA-444	WAF4052	VA-383	WAF5698	VA-435
872683	VO-95	WAF2786	VA-216	WAF3927	VA-443	WAF4054	VA-384	WAF5699	VA-442
897321	VO-95	WAF2883	VA-223	WAF3933	VA-204	WAF4055	VA-250	WAF5701	VA-490
9134577	VCA-1161	WAF2884	VA-224	WAF3935	VA-323	WAF4057	VA-358	WAF5848	VA-394
9141094	VFAP-7912	WAF2893	VA-246	WAF3936	VA-365	WAF4058	VA-385	WAF5857	VA-159
91410944	VFAP-7912	WAF293	VA-86	WAF3938	VA-309	WAF4062	VA-268	WAF602	VA-40
9171296	VCA-1161	WAF2944	VA-336	WAF3940	VA-448	WAF4063	VA-366	WAF6900	VA-267
91712968	VCA-1161	WAF2956	VA-203	WAF3954	VA-187	WAF4064	VA-378	WAF6908	VA-288

CAUTION: For general references only. Check catalog for correct filter application. Any use of this interchange to determine filter application is done at the installers risk.

PRECAUCION: Solamente para referencias generales. Revise el catálogo para la correcta aplicación del filtro. Cualquier uso de la referencia cruzada para determinar la aplicación del filtro es riesgo del instalador. ATTENTION : Seulement pour les références d'ordre général. Contrôler l'application correcte du filtre avec le catalogue. Toute utilisation de moyens afin de déterminer l'application d'un filtre est faite aux risques de l'installateur.

Cross Reference

Table da equivalencias da fabricantes

Code de renvoi au fabricant

MFR'S NUMBER	REPLACEMENT NUMBER	MFR'S NUMBER	REPLACEMENT NUMBER	MFR'S NUMBER	REPLACEMENT NUMBER	MFR'S NUMBER	REPLACEMENT NUMBER	MFR'S NUMBER	REPLACEMENT NUMBER
WARNER		WAF7958	VA-270	WCAF1795	VCA-1156	WCAF1896	VCA-1120	WPH253	VO-95
WAF6910	VA-298	WAF7959	VA-152	WCAF1797	VCA-1065	WCAF1897	VCA-1080	WPH2702	VO-60
WAF6928	VA-463	WAF7964	VA-191	WCAF1800	VCA-1135	WCAF1898	VCA-1077	WPH2801	VO-35
WAF6935	VA-501	WAF7965	VA-150	WCAF1801	VCA-1139	WCAF1899	VCA-1177	WPH2808	VO-106
WAF773	VA-38	WAF7973	VA-341	WCAF1802	VCA-1070	WCAF1900	VCA-1081	WPH2815	VO-15
WAF7819	VA-401	WAF7974	VA-166	WCAF1803	VCA-1096	WCAF1903	VCA-1082	WPH2817	VO-27
WAF7819	VA-96	WAF7975	VA-156	WCAF1803	VCA-1096	WCAF1904	VCA-1184	WPH2827	VO-25
WAF7823	VA-261	WAF7976	VA-346	WCAF1804	VCA-1048	WCAF1907	VCA-1175	WPH2835	VO-1
WAF7825	VA-97	WAF7977	VA-361	WCAF1805	VCA-2033	WCAF1908	VCA-1174	WPH2835	VO-118
WAF7826	VA-416	WAF7978	VA-399	WCAF1806	VCA-1170	WCAF1911	VCA-1097	WPH2835	VO-118
WAF7827	VA-158	WAF7981	VA-155	WCAF1807	VCA-1102	WCAF1914	VCA-1173	WPH2835	VO-15
WAF7828	VA-83	WAF7982	VA-172	WCAF1808	VCA-1145	WCAF1918	VCA-1176	WPH2835	VO-25
WAF7831	VA-370	WAF7983	VA-345	WCAF1809	VCA-1134	WCAF1921	VCA-1179	WPH2840	VO-40
WAF7832	VA-98	WAF7984	VA-154	WCAF1810	VCA-1103	WCAF1924	VCA-1193	WPH2855	VO-135
WAF7833	VA-99	WAF7985	VA-333	WCAF1810	VCA-1103	WCAF1925	VCA-1186	WPH2856A	VO-19
WAF7836	VA-101	WAF7989	VA-347	WCAF1811	VCA-1172	WCAF1941	VCA-1178	WPH2873	VO-123
WAF7841	VA-102	WAF7990	VA-165	WCAF1812	VCA-1074	WCAF1944	VCA-1181	WPH2876	VO-106
WAF7842	VA-103	WAF7991	VA-170	WCAF1813	VCA-1041	WCAF1945	VCA-1189	WPH2876	VO-106
WAF7843	VA-104	WAF7992	VA-279	WCAF1814	VCA-1035	WCAF1947	VCA-1191	WPH2876	VO-106
WAF7845	VA-105	WAF7996	VA-169	WCAF1815	VCA-1044	WCAF1948	VCA-1190	WPH2878	VO-175
WAF7849	VA-124	WAF7997	VA-400	WCAF1816	VCA-1031	WCAF1949	VCA-1188	WPH2892	VO-143
WAF785	VA-44	WAF7998	VA-192	WCAF1817	VCA-1075	WCAF1950	VCA-2035	WPH2903	VO-52
WAF7854	VA-404	WAF7999	VA-193	WCAF1818	VCA-1066	WCAF1953	VCA-1185	WPH2905	VO-86
WAF7854	VFAP-7854	WAF8248	VA-147	WCAF1820	VCA-1047	WCAF1957	VCA-1195	WPH2992	VO-124
WAF7857	VFAP-7857	WAF9010	VA-163	WCAF1821	VCA-1113	WCAF1961	VCA-2043	WPH44	VO-108
WAF7858	VA-106	WAF9098	VA-196	WCAF1823B	VCA-1101	WCAF7702	VCA-1026	WPH44	VO-58
WAF7859	VFAP-7859	WAF917	VFAP-917	WCAF1825	VCA-1138	WCAF7721	VCA-1162	WPH453	VO-93
WAF7861	VA-387	WAF925	VA-85	WCAF1829	VCA-1159	WCAF7721	VCA-1162	WPH454	VO-65
WAF7862	VA-107	WAF9546	VA-335	WCAF1830	VCA-1146	WCAF7722	VCA-1127	WPH454	VO-65
WAF7863	VA-108	WAF974	VA-65	WCAF1832	VCA-1155	WCAF7722	VCA-1127	WPH47	VO-16
WAF7867	VA-125	WAF9911	VA-429	WCAF1834	VCA-1089	WCAF7742	VCA-1165	WPH47	VO-55
WAF7872	VA-109	WAF9912	VA-306	WCAF1835	VCA-1054	WCAF7749	VCA-1168	WPH477	VO-122
WAF7873	VA-110	WAF9916	VA-451	WCAF1839	VCA-1046	WCAF7757	VCA-1164	WPH48	VO-200
WAF7874	VA-89	WAF9918	VA-430	WCAF1840	VCA-1158	WCAF7759	VCA-1131	WPH48	VO-201
WAF7875	VA-338	WCAF10004	VCA-2055	WCAF1844	VCA-1104	WCAF7782	VCA-1129	WPH48	VO-88
WAF7876	VA-128	WCAF10009	VCA-2051	WCAF1845	VCA-1069	WCAF7796	VCA-1124	WPH48	VO-88
WAF7877	VA-90	WCAF1700	VCA-1157	WCAF1846	VCA-1051	WCAF7796	VCA-1124	WPH488	VO-160
WAF7878	VA-111	WCAF1703	VCA-1001	WCAF1847	VCA-1142	WCAF7799	VCA-1133	WPH610	VO-101
WAF7879	VA-112	WCAF1704	VCA-1021	WCAF1848	VCA-1038	WCAF7799	VA-324	WPH820	VO-88
WAF7880	VA-113	WCAF1706	VCA-1002	WCAF1849	VCA-1034	WCAF7799	VA-93	WP1009	VO-114
WAF7882	VA-114	WCAF1707	VCA-1003	WCAF1850	VCA-1049	WCAF7799	VA-174	WP1014	VO-142
WAF7883	VA-395	WCAF1708	VCA-1167	WCAF1851	VCA-1110	WCAF7799	VA-410	WP1015	VO-153
WAF7884	VA-157	WCAF1713	VCA-1017	WCAF1852	VCA-1052	WCAF7799	VA-122	WP1016	VO-164
WAF7885	VFAP-7885	WCAF1716	VCA-1161	WCAF1855	VCA-1144	WCAF7799	VCA-239	WP1017	VO-117
WAF7892	VFAP-7892	WCAF1717	VCA-1123	WCAF1857	VCA-1194	WCAF7799	VA-218	WP1023	VO-174
WAF7893	VFAP-7893	WCAF1720	VCA-1060	WCAF1861	VCA-1036	WCAF7799	VA-381	WP1026	VO-167
WAF7905	VA-131	WCAF1726	VCA-1122	WCAF1862	VCA-1050	WCAF7799	VA-295	WP1028	VO-165
WAF7906	VA-132	WCAF1730	VCA-1039	WCAF1863	VCA-1114	WCAF7799	VA-469	WP1035	VO-166
WAF7907	VA-148	WCAF1739	VCA-1040	WCAF1864	VCA-1064	WCAF7799	VA-411	WP1037	VO-168
WAF7908	VFAP-7908	WCAF1742	VCA-1022	WCAF1865	VCA-1053	WCAF7799	VA-349	WP1051	VO-173
WAF7910	VA-129	WCAF1742K	VCA-1022K	WCAF1866	VCA-1153	WCAF7799	VA-177	WP1069	VO-172
WAF7911	VA-144	WCAF1743	VCA-1008	WCAF1867	VCA-1062	WCAF7799	VA-272	WP1070	VO-169
WAF7912	VFAP-7912	WCAF1745	VCA-1125	WCAF1868	VCA-1059	WCAF7799	VA-266	WP1072	VO-37
WAF7913	VA-135	WCAF1747	VCA-1160	WCAF1869	VCA-1055	WCAF7799	VA-462	WP2062	VO-115
WAF7914	VA-153	WCAF1751	VCA-1042	WCAF1870	VCA-1109	WCAF7799	VA-264	WP2129	VO-67
WAF7917	VA-116	WCAF1754	VCA-1029	WCAF1872	VCA-1078C	WCAF7799	VA-380	WP2224	VO-73
WAF7918	VA-136	WCAF1755	VCA-1020	WCAF1873	VCA-1061	WCAF7799	VA-167	WP2902	VO-144
WAF7919	VA-117	WCAF1756	VCA-1163	WCAF1874	VCA-1116	WCAF7799	VO-104	WP2923	VO-119
WAF7920	VA-118	WCAF1758	VCA-1012	WCAF1875	VCA-1171	WCAF7799	VO-63	WP3040	VO-77
WAF7922	VA-396	WCAF1762	VCA-1030	WCAF1876	VCA-1115	WCAF7799	VO-75	WP3244	VO-76
WAF7935	VA-138	WCAF1764	VCA-1028	WCAF1878	VCA-1094	WCAF7799	VO-170	WP3968	VO-137
WAF7937	VA-397	WCAF1765	VCA-1037	WCAF1879	VCA-1076	WCAF7799	VO-64	WP3969	VO-129
WAF7938	VA-146	WCAF1766	VCA-1014	WCAF1880	VCA-1072	WCAF7799	VO-46	WP3972	VO-130
WAF7939	VA-315	WCAF1767	VCA-1106	WCAF1882	VCA-1147	WCAF7799	VO-81	WP3986	VO-85
WAF7942	VA-354	WCAF1770	VCA-1013	WCAF1883	VCA-1117	WCAF7799	VO-56	WP4456	VO-78
WAF7943	VA-339	WCAF1771	VCA-1024	WCAF1884	VCA-1057	WCAF7799	VO-56	WP8170	LC-8170
WAF7944	VA-178	WCAF1774	VCA-1067	WCAF1885	VCA-1118	WCAF7799	VO-86	WP8198	VO-74
WAF7946	VA-137	WCAF1779	VCA-1043	WCAF1886	VCA-1093	WCAF7799	VO-86	WP833	LC-833
WAF7949	VA-350	WCAF1781	VCA-1063	WCAF1887	VCA-1071	WCAF7799	VO-108	WP834	LC-834
WAF7953	VA-190	WCAF1789	VCA-1056	WCAF1890	VCA-1073	WCAF7799	VO-95	WP837	VO-66
WAF7954	VA-151	WCAF1792	VCA-1068	WCAF1891	VCA-1098	WCAF7799	VO-95	WP838	VO-127

CAUTION: For general references only. Check catalog for correct filter application. Any use of this interchange to determine filter application is done at the installers risk.
 PRECAUCION: Solamente para referencias generales. Revise el catálogo para la correcta aplicación del filtro. Cualquier uso de la referencia cruzada para determinar la aplicación del filtro es riesgo del instalador. ATTENTION : Seulement pour les références d'ordre général. Contrôler l'application correcte du filtre avec le catalogue. Toute utilisation de moyens afin de déterminer l'application d'un filtre est faite aux risques de l'installateur.

Cross Reference

Table da equivalencias da fabricantes

Code de renvoi au fabricant

MFR'S NUMBER	REPLACEMENT NUMBER	MFR'S NUMBER	REPLACEMENT NUMBER	MFR'S NUMBER	REPLACEMENT NUMBER	MFR'S NUMBER	REPLACEMENT NUMBER	MFR'S NUMBER	REPLACEMENT NUMBER
WARNER		WA10339	VA-456	WP10320	VCA-2035	24765	VCA-1124	42096	VA-45
WP842	VO-97	WA10394	VA-466	WP10320	VCA-2051	24771	VCA-1157	42098	VA-2
WP843	VO-62	WA10403	VA-490	WP10367	VCA-1062	24773	VCA-1001	42101	VA-403
WP8445	LC-8445	WA10414	VA-459	WP10369	VCA-2055	24780	VCA-1002	42133	VA-69
WP845	VO-70	WA10416	VA-454	WP2100	VCA-1178	24782	VCA-1167	42164	VA-247
WP846	VO-150	WA10417	VA-464	WP9309	VCA-1108	24794	VCA-1053	42177	VFAP-7912
WP856	VO-71	WA10418	VA-453	24012	VCA-1171	24805	VCA-1003	42181	VA-270
WP907	VO-138	WA10420	VA-465	24013	VCA-1075	24807	VCA-1008	42188	VA-196
WP929	VO-128	WA10422	VA-488	24014	VCA-1076	24808	VCA-1163	42190	VA-342
WP960	VO-80	WA10646	VA-471	24015	VCA-1072	24811	VCA-1021	42214	VA-395
WP961	VO-94	WA10649	VA-461	24017	VCA-1073	24812	VCA-1022	42295	VA-157
WP962	VO-112	WA10650	VA-468	24020	VCA-1038	24813	VCA-1165	42306	VA-399
WP964	VO-82	WA10655	VA-485	24030	VCA-1055	24814	VCA-1169	42324	VA-321
WP966	VO-92	WA10679	VA-462	24036	VCA-1098	24815	VCA-1063	42329	VA-164
WP967	VO-84	WA10695	VA-469	24046	VCA-1094	24816	VCA-1020	42333	VA-408
WP968	VO-87	WA10697	VA-463	24048	VCA-1077	24817	VCA-1012	42341	VA-142
WP969	VO-91	WA10713	VA-498	24053	VCA-1120	24818	VCA-1040	42351	VA-380
WP972	VO-90	WA10718	VA-467	24065	VCA-1049	24821	VCA-1161	42384	VA-137
WP975	VO-120	WA10813	VA-497	24068	VCA-1118	24822	VCA-1026	42385	VA-149
WP978	VO-111	WA10831	VA-501	24080	VCA-1071	24823	VCA-1096	42389	VA-154
WP979	VO-96	WA10841	VA-499	24094	VA-111	24826	VCA-1089	42412	VA-333
WP980	VO-102	WL10001	VO-123	24103	VCA-1175	24829	VCA-1052	42461	VA-394
WP981	VO-98	WL10010	VO-114	24118	VCA-1106	24853	VCA-1139	42468	VA-371
WP982	VO-99	WL10010XP	VO-114	24148	VCA-1116	24854	VCA-1048	42472	VA-138
WP983	VO-140	WL10021	VO-153	24191	VCA-1078C	24855	VCA-1159	42476	VA-146
WP985	VO-103	WL10024	VO-117	24200	VCA-1109	24857	VCA-1068	42479	VA-146
WP986	VO-141	WL10032	VO-109	24201	VCA-1061	24863	VCA-1039	42484	VA-162
WP987	VO-131	WL10033	VO-167	24211	VCA-1183	24864	VCA-1168	42486	VA-397
WP989	VO-109	WL10050	VO-115	24212	VCA-1110	24865	VCA-1029	42487	VA-259
WP990	VO-110	WL10056	VO-165	24300	VCA-1062	24868	VCA-1164	42488	VA-271
WP992	VO-149	WL10058	VO-170	24302	VCA-1097	24869	VCA-1043	42524	VA-140
WP993	VO-116	WL10059	VO-151	24313	VCA-1069	24871	VCA-1037	42551	VA-193
WP995	VO-132	WL10060	VO-142	24322	VCA-1166	24872	VCA-1030	42564	VA-165
WP996	VO-121	WL10068	VO-25	24367	VCA-1059	24873	VCA-1028	42612	VA-207
WP997	VO-151	WL10078	VO-106	24400	VCA-1038	24875	VCA-1014	42625	VA-363
WP998	VO-133	WL10082	VO-109	24419	VCA-1081	24876	VCA-1017	42697	VA-411
WIX		WL10116	VO-106	24473	VCA-1162	24877	VCA-1122	42725	VA-160
WA10000	VA-344	WL10164	VO-109	24474	VCA-1022K	24878	VCA-1060	42727	VA-345
WA10005	VA-450	WL10223	VO-168	24475	VCA-1134	24879	VCA-1054	42728	VA-150
WA10006	VA-473	WL10224	VO-25	24477	VCA-1101	24881	VCA-1139	42729	VA-161
WA10008	VA-303	WL10241	VO-174	24478	VCA-1056	24882	VCA-1065	42731	VA-174
WA10022	VA-392	WL10255	VO-88	24479	VCA-1044	24883	VCA-1014	42737	VA-379
WA10036	VA-429	WL10286	VO-172	24482	VCA-1046	24884	VCA-1125	42740	VA-172
WA10048	VA-306	WL10290	VO-200	24483	VCA-1031	24893	VCA-1129	42749	VA-350
WA10053	VA-419	WL10331	VO-98	24484	VCA-1138	24894	VCA-1024	42750	VA-179
WA10058	VA-437	WL10332	VO-175	24488	VCA-1031	24897	VCA-1013	42752	VA-377
WA10085	VA-440	WL7155	VO-155	24489	VCA-1135	24899	VCA-1160	42793	VA-149
WA10095	VA-298	WL7323	VO-25	24517	VCA-1035	24900	VCA-1042	42797	VA-152
WA10096	VA-434	WL7509	VO-91	24524	VCA-1110	24901	VCA-1067	42799	VA-199
WA10127	VA-417	WL7515	VO-164	24526	VCA-1144	24902	VCA-1155	42800	VA-355
WA10135	VA-430	WL7522	VO-166	24569	VCA-1014	24903	VCA-1170	42822	VA-400
WA10164	VA-331	WP10009	VCA-1082	24579	VCA-1064	24905	VCA-1133	42823	VA-352
WA10212	VA-432	WP10074	VCA-1080	24579	VCA-1070	24907	VCA-1070	42825	VA-190
WA10215	VA-438	WP10083	VCA-1051	24590	VCA-1078	24909	VCA-2033	42826	VA-340
WA10253	VA-308	WP10084	VCA-1174	24600	VCA-1115	33046	VG-2	42831	VA-188
WA10254	VA-308	WP10105	VCA-1102	24619	VCA-1177	33097	VG-16	42834	VA-208
WA10255	VA-424	WP10129	VCA-1173	24673	VCA-1162	33097MP	VG-16	42838	VA-386
WA10256	VA-425	WP10142	VCA-1176	24682	VCA-1113	33296	VG-32	42839	VA-337
WA10257	VA-490	WP10155	VCA-1181	24683	VCA-1041	33296MP	VG-32	42843	VA-180
WA10261	VA-284	WP10178	VCA-1179	24684	VCA-1047	33311	VG-33	42844	VA-202
WA10268	VA-453	WP10179	VCA-1178	24685	VCA-1146	33311MP	VG-33	42846	VA-177
WA10269	VA-431	WP10192	VCA-1184	24686	VCA-1126	33481	VG-14	42859	VA-204
WA10271	VA-418	WP10195	VCA-1186	24687	VCA-1102	33481MP	VG-14	42863	VA-362
WA10296	VA-428	WP10207	VCA-1188	24688	VCA-1172	33484	VG-30	42864	VA-336
WA10312	VA-449	WP10234	VCA-1075	24689	VCA-1066	33484MP	VG-30	42879	VA-359
WA10313	VA-179	WP10263	VCA-1193	24725	VCA-1036	42013	VA-181	42885	VA-194
WA10315	VA-430	WP10265	VCA-1190	24752	VCA-1167	42015	VA-147	42891	VA-151
WA10316	VA-451	WP10266	VCA-1185	24753	VCA-1144	42020	VA-321	42897	VA-90
WA10317	VA-453	WP10277	VCA-2043	24756	VCA-1147	42023	VA-361	42972	VA-325
WA10335	VA-458	WP10316	VCA-1195	24757	VCA-1131	42086	VA-185	42993	VA-48
WA10337	VA-455	WP10319	VCA-1191	24761	VCA-1057	42088	VA-402	46006	VFAP-7859

CAUTION: For general references only. Check catalog for correct filter application. Any use of this interchange to determine filter application is done at the installers risk.

PRECAUCION: Solamente para referencias generales. Revise el catálogo para la correcta aplicación del filtro. Cualquier uso de la referencia cruzada para determinar la aplicación del filtro es riesgo del instalador. ATTENTION : Seulement pour les références d'ordre général. Contrôler l'application correcte du filtre avec le catalogue. Toute utilisation de moyens afin de déterminer l'application d'un filtre est faite aux risques de l'installateur.

Cross Reference

Table da equivalencias da fabricantes

Code de renvoi au fabricant

MFR'S NUMBER	REPLACEMENT NUMBER	MFR'S NUMBER	REPLACEMENT NUMBER	MFR'S NUMBER	REPLACEMENT NUMBER	MFR'S NUMBER	REPLACEMENT NUMBER	MFR'S NUMBER	REPLACEMENT NUMBER
WIX		46349	VFAP-1612	49022	VA-300	49211	VA-393	49825	VA-326
46017	VA-102	46358	VFAP-7908	49023	VA-278	49220	VA-184	49830	VA-457
46018	VA-321	46388	VA-135	49030	VA-234	49223	VA-214	49843	VA-318
46026	VA-103	46390	VA-120	49031	VA-292	49224	VA-351	49846	VA-329
46027	VA-97	46398	VA-338	49034	VA-442	49225	VA-244	49873	VA-375
46028	VA-104	46406	VFAP-1643	49038	VA-301	49229	VA-364	49876	VA-349
46030	VA-401	46416	VA-114	49040	VA-221	49230	VA-275	49883	VA-223
46035	VA-91	46417	VA-93	49041	VA-220	49235	VA-316	49886	VA-239
46036	VA-44	46418	VA-94	49042	VA-202	49240	VA-445	49888	VA-373
46040	VA-38	46419	VFA-1641	49043	VA-313	49244	VA-327	49890	VA-241
46043	VA-408	46425	VA-112	49048	VA-310	49247	VA-302	49893	VA-246
46044	VA-261	46428	VA-404	49049	VA-287	49250	VA-265	49894	VA-254
46051	VFAP-7854	46440	VA-92	49051	VA-328	49264	VA-427	49901	VA-267
46053	VA-370	46441	VA-320	49052	VA-227	49270	VA-366	49902	VA-266
46057	VA-99	46443	VA-117	49053	VA-216	49285	VA-396	49907	VA-341
46058	VA-158	46444	VA-118	49054	VA-211	49288	VA-299	49926	VA-154
46064	VA-83	46462	VA-178	49056	VA-223	49293	VA-354	49933	VA-232
46077	VA-90	46463	VA-136	49057	VA-233	49310	VA-309	49946	VA-272
46080	VA-107	46464	VA-339	49058	VA-252	49314	VA-295	51034	VO-15
46081	VA-129	46465	VA-159	49059	VA-372	49320	VA-257	51036	VO-55
46083	VA-98	46472	VA-116	49063	VA-184	49344	VA-315	51036MP	VO-55
46086	VA-321	46484	VA-410	49064	VA-217	49352	VCA-1034	51040	VO-16
46088	VA-269	46493	VA-279	49065	VA-212	49353	VCA-1050	51040MP	VO-16
46093	VA-88	46503	VA-65	49066	VA-360	49355	VCA-1158	51042	VO-58
46095	VFAP-7857	46573	VA-169	49067	VA-213	49357	VCA-1153	51042MP	VO-58
46097	VA-416	46646	VA-191	49069	VA-201	49358	VCA-1037	51045	VO-108
46098	VA-106	46648	VA-122	49070	VA-235	49359	VCA-1114	51046	VO-65
46105	VFAP-7893	46653	VA-335	49071	VA-360	49362	VA-332	51049	VO-108
46108	VA-101	46659	VA-114	49073	VA-312	49363	VCA-1068	51060	VO-56
46109	VA-125	46673	VA-163	49085	VA-374	49368	VCA-1075	51060MP	VO-56
46116	VA-86	46674	VA-166	49086	VA-242	49371	VCA-1103	51061	VO-56
46117	VA-108	46677	VA-155	49093	VCA-1093	49372	VCA-1127	51064	VO-106
46120	VA-40	46678	VA-324	49094	VA-335	49377	VCA-1051	51064MP	VO-106
46126	VA-66	46699	VA-156	49100	VA-383	49400	VA-268	51067	VO-136
46128	VA-413	46728	VA-167	49101	VCA-1061	49429	VA-219	51068	VO-95
46133	VA-69	46798	VA-347	49102	VA-236	49430	VA-273	51068MP	VO-95
46134	VA-205	46802	VA-192	49104	VA-231	49450	VA-265	51069	VO-65
46139	VA-65	46803	VA-270	49110	VA-378	49459	VA-388	51069MP	VO-65
46144	VFAP-917	46804	VA-182	49113	VA-230	49460	VA-250	51083	VO-52
46153	VA-78	46814	VA-205	49114	VA-215	49461	VA-317	51084	VO-95
46162	VA-96	46831	VA-183	49115	VA-200	49466	VCA-1104	51085	VO-95
46174	VA-70	46832	VA-184	49116	VA-251	49468	VA-423	51085MP	VO-95
46180	VA-85	46834	VA-171	49117	VA-203	49475	VA-280	51088	VO-15
46195	VA-144	46835	VA-330	49119	VA-210	49480	VA-334	51143	VO-134
46213	VA-105	46873	VA-206	49120	VA-237	49498	VA-263	51145	VO-62
46215	VA-153	46879	VA-189	49121	VA-202	49530	VA-297	51160	LC-834
46221	VA-389	46887	VA-175	49122	VA-365	49545	VA-367	51170	VO-144
46242	VA-414	46888	VA-195	49123	VA-357	49555	VA-444	51185	LC-833
46244	VA-84	46889	VA-187	49136	VA-382	49570	VA-391	51186	VO-74
46245	VA-148	46902	VA-176	49143	VA-448	49590	VA-426	51189	VO-95
46253	VA-260	46914	VA-198	49145	VA-222	49593	VA-446	51190	VO-55
46253	VA-322	46916	VA-356	49146	VA-289	49600	VA-384	51191	VO-159
46255	VA-411	46917	VA-269	49154	VA-381	49604	VA-284	51212	VO-150
46271	VA-387	46924	VA-197	49155	VA-248	49610	VA-390	51213	LC-8445
46272	VA-111	46930	VA-264	49156	VA-228	49630	VA-307	51215	VO-25
46273	VFAP-7892	46935	VA-224	49157	VA-343	49634	VA-225	51223	LC-8170
46288	VFAP-7859	46938	VA-314	49158	VA-296	49640	VA-319	51224	VO-143
46289	VA-89	46975	VA-186	49170	VA-202	49651	VA-280	51226	VO-69
46293	VA-111	49000	VA-238	49172	VA-209	49670	VA-311	51227	VO-119
46298	VA-132	49001	VA-282	49175	VA-243	49700	VCA-1117	51228	VO-86
46301	VA-110	49004	VA-358	49180	VA-247	49704	VA-452	51231	VO-86
46302	VA-109	49005	VA-368	49184	VA-218	49727	VA-255	51246	VO-70
46303	VA-113	49006	VA-378	49185	VA-353	49728	VA-447	51258	VO-108
46308	VA-128	49009	VA-291	49186	VA-226	49730	VA-285	51287	VO-135
46316	VA-412	49010	VA-234	49187	VA-249	49737	VA-286	51307	VO-95
46318	VA-131	49012	VA-198	49191	VA-240	49739	VA-296	51311	VO-95
46320	VFAP-7865	49014	VA-290	49192	VA-229	49746	VA-293	51312	VO-95
46322	VA-170	49016	VA-245	49200	VA-294	49750	VA-304	51315	VO-118
46327	VA-124	49017	VA-288	49201	VA-253	49756	VA-273	51316	VO-95
46339	VFAP-1613	49018	VA-258	49208	VA-443	49760	VA-305	51324	VO-19
46340	VA-346	49020	VA-274	49210	VA-283	49800	VA-385	51333	VO-15

CAUTION: For general references only. Check catalog for correct filter application. Any use of this interchange to determine filter application is done at the installers risk.
 PRECAUCION: Solamente para referencias generales. Revise el catálogo para la correcta aplicación del filtro. Cualquier uso de la referencia cruzada para determinar la aplicación del filtro es riesgo del instalador. ATTENTION : Seulement pour les références d'ordre général. Contrôler l'application correcte du filtre avec le catalogue. Toute utilisation de moyens afin de déterminer l'application d'un filtre est faite aux risques de l'installateur.

Cross Reference

Table da equivalencias da fabricantes

Code de renvoi au fabricant

MFR'S NUMBER	REPLACEMENT NUMBER	MFR'S NUMBER	REPLACEMENT NUMBER	MFR'S NUMBER	REPLACEMENT NUMBER	MFR'S NUMBER	REPLACEMENT NUMBER	MFR'S NUMBER	REPLACEMENT NUMBER
WIX		57038	VO-69	57510	VO-106				
51334	VO-106	57040	VO-106	57512	VO-111				
51334	VO-106	57040	VO-106	57521	VO-161				
51334	VO-52	57041	VO-96	57526	VO-110				
51342	VO-15	57042	VO-99	57530	VO-40				
51344	VO-106	57045	VO-88	57560	VO-140				
51347	VO-52	57046	VO-52	57561	VO-101				
51348	VO-25	57047	VO-84	57563	VO-150				
51348MP	VO-25	57050	VO-109	57620	VO-64				
51355	VO-93	57055	VO-106	57620MP	VO-64				
51356	VO-106	57059	VO-149	57674	VO-98				
51357	VO-106	57060	VO-88	57712	VO-106				
51361	VO-15	57060MP	VO-88	57806	VO-97				
51362	VO-95	57061	VO-90	57830	VO-106				
51364	VO-15	57062	VO-129	57899	VO-88				
51365	VO-106	57063	VO-88	WIX XP					
51365XP	VO-106	57064	VO-102	51223XP	LC-8170				
51366	VO-40	57073	VO-88	51226XP	VO-103				
51367	VO-25	57077	VO-120	57060XP	VO-152				
51369	VO-145	57078	VO-103	57082XP	VO-76				
51372	VO-88	57079	VO-78	57151XP	VO-104				
51372MP	VO-88	57082	VO-76	57202XP	VO-75				
51376	VO-163	57083	VO-77	57203XP	VO-80				
51378	VO-60	57090	VO-67	57327XP	VO-91				
51381	VO-19	57092	VO-106	57526XP	VO-110				
51389	VO-106	57099	VO-65						
51391	VO-25	57141	VO-106						
51392	VO-27	57143	VO-122						
51393	VO-15	57145	VO-40						
51394	VO-40	57148	VO-25						
51394MP	VO-40	57151	VO-104						
51395	VO-40	57162	VO-139						
51396	VO-40	57170	VO-144						
51452	VO-15	57171	VO-128						
51452MP	VO-15	57172	VO-143						
51512	VO-15	57173	VO-87						
51515	VO-1	57175	VO-112						
51515MP	VO-1	57181	VO-25						
51516	VO-118	57186	VO-85						
51516MP	VO-118	57187	VO-85						
51521	VO-95	57189	VO-131						
51522	VO-108	57202	VO-75						
51522MP	VO-108	57202XP	VO-75						
51525	VO-1	57203	VO-80						
51568	VO-106	57204	VO-92						
51607	VO-64	57210	VO-71						
51607MP	VO-64	57211	VO-127						
51626	VO-35	57241	VO-124						
51627	VO-156	57250	VO-99						
51630	VO-37	57254	VO-145						
51649	VO-162	57260	VO-121						
51673	VO-162	57262	VO-132						
51675	VO-146	57279	VO-141						
51734	VO-63	57301	VO-118						
51734MP	VO-63	57302	VO-86						
51742	VO-46	57303	VO-82						
51742MP	VO-46	57310	VO-96						
51762	VO-118	57311	VO-81						
51764	VO-118	57314	VO-81						
51775	VO-1	57323	No Attached Cap	VO-81					
51785	VO-25	57327	VO-91						
51798	VO-163	57328	VO-137						
51798MP	VO-163	57329	VO-94						
51833	VO-162	57330	VO-138						
57000	VO-25	57334	VO-106						
57002	VO-106	57341	VO-116						
57021	VO-66	57356	VO-106						
57023	VO-25	57371	VO-25						
57029	VO-99	57430	VO-95						
57032	VO-16	57462	VO-133						
57033	VO-73	57502	VO-88						

CAUTION: For general references only. Check catalog for correct filter application. Any use of this interchange to determine filter application is done at the installers risk.

PRECAUCION: Solamente para referencias generales. Revise el catálogo para la correcta aplicación del filtro. Cualquier uso de la referencia cruzada para determinar la aplicación del filtro es riesgo del instalador. ATTENTION : Seulement pour les références d'ordre général. Contrôler l'application correcte du filtre avec le catalogue. Toute utilisation de moyens afin de déterminer l'application d'un filtre est faite aux risques de l'installateur.

Installation Instructions

Instrucciones de instalación / Instructions d'installation

Number Número Nombre	Page Página Page	Number Número Nombre	Page Página Page	Number Número Nombre	Page Página Page	Number Número Nombre	Page Página Page
VCA-1001.....	3-3	VCA-1052.....	3-39	VCA-1098	3-74	VCA-1155.....	3-109
VCA-1002	3-4	VCA-1053	3-40	VCA-1101	3-75	VCA-1156.....	3-110
VCA-1003	3-5	VCA-1054	3-41	VCA-1102.....	3-76	VCA-1157	3-111
VCA-1008	3-6	VCA-1055	3-42	VCA-1103.....	3-77	VCA-1158.....	3-80
VCA-1010.....	3-7	VCA-1056	3-43	VCA-1104.....	3-78	VCA-1159.....	3-112
VCA-1012.....	3-8	VCA-1057.....	3-44	VCA-1106.....	3-79	VCA-1160.....	3-113
VCA-1013.....	3-9	VCA-1058	3-45	VCA-1108.....	3-80	VCA-1161	3-114
VCA-1017	3-10	VCA-1059.....	3-46	VCA-1109.....	3-81	VCA-1162	3-115
VCA-1020.....	3-11	VCA-1060	3-47	VCA-1110	3-82	VCA-1163.....	3-116
VCA-1021.....	3-12	VCA-1061.....	3-48	VCA-1113	3-83	VCA-1164.....	3-117
VCA-1022.....	3-13	VCA-1062	3-49	VCA-1114	3-84	VCA-1165.....	3-13
VCA-1022K	3-14	VCA-1063	3-50	VCA-1115	3-85	VCA-1166.....	3-16
VCA-1024.....	3-15	VCA-1064	3-51	VCA-1116	3-86	VCA-1167	3-118
VCA-1026.....	3-16	VCA-1065	3-52	VCA-1117	3-87	VCA-1168.....	3-7
VCA-1028.....	3-17	VCA-1066	3-53	VCA-1118	3-88	VCA-1169.....	3-61
VCA-1029.....	3-18	VCA-1067.....	3-54	VCA-1120.....	3-89	VCA-1170	3-119
VCA-1030	3-19	VCA-1068	3-55	VCA-1122.....	3-90	VCA-1171	3-120
VCA-1031.....	3-20	VCA-1069	3-56	VCA-1123.....	3-91	VCA-1172	3-121
VCA-1032	3-21	VCA-1070.....	3-57	VCA-1124	3-92	VCA-1173	3-122
VCA-1034	3-22	VCA-1071.....	3-58	VCA-1125.....	3-93	VCA-1174	3-123
VCA-1035	3-23	VCA-1072.....	3-59	VCA-1126.....	3-79	VCA-1175	3-124
VCA-1036	3-24	VCA-1073.....	3-60	VCA-1127	3-94	VCA-1176	3-125
VCA-1037.....	3-25	VCA-1074.....	3-61	VCA-1129.....	3-95	VCA-1177	3-126
VCA-1038	3-26	VCA-1075.....	3-62	VCA-1131	3-96	VCA-1178	3-127
VCA-1039	3-27	VCA-1076.....	3-63	VCA-1133.....	3-97	VCA-1179	3-128
VCA-1040	3-28	VCA-1077.....	3-64	VCA-1134.....	3-98	VCA-1181	3-129
VCA-1041.....	3-29	VCA-1078C.....	3-65	VCA-1135.....	3-99	VCA-1183.....	3-130
VCA-1042.....	3-30	VCA-1078.....	3-65	VCA-1138.....	3-100	VCA-1184.....	3-130
VCA-1043	3-31	VCA-1080	3-66	VCA-1139.....	3-101	VCA-1185.....	3-131
VCA-1044	3-32	VCA-1081.....	3-67	VCA-1142.....	3-102	VCA-1186.....	3-132
VCA-1046	3-33	VCA-1082	3-68	VCA-1144.....	3-103	VCA-1187	3-133
VCA-1047.....	3-34	VCA-1089	3-69	VCA-1145.....	3-104	VCA-1188.....	3-134
VCA-1048	3-35	VCA-1093	3-70	VCA-1146.....	3-105	VCA-1189.....	3-135
VCA-1049.....	3-36	VCA-1094	3-71	VCA-1147	3-106	VCA-1190.....	3-136
VCA-1050	3-37	VCA-1096	3-72	VCA-1150.....	3-107	VCA-1191	3-137
VCA-1051.....	3-38	VCA-1097.....	3-73	VCA-1153.....	3-108	VCA-1192.....	3-138

Installation Instructions

Instrucciones de instalación / Instructions d'installation

Number	Page
Número	Página
Nombre	Page
VCA-1193	3-139
VCA-1194	3-140
VCA-1195	3-141
VCA-2033	3-142
VCA-2035	3-143
VCA-2043	3-144
VCA-2051	3-145
VCA-2055	3-146



Application:

Ford Taurus | Mercury Sable

Tools:

Phillips Screwdriver & 5/16" Nut Driver

Location of cabin filter:

In front of the windshield under the cowl vent screen on the passenger side of the vehicle.

To remove existing filter:

1. Release and open hood.
2. Rotate and remove the four plastic cowl vent screws (**H007**) located on the cowl vent screen. (**Figure 1**).
3. Remove the three push-on clips (**H006**). (**Figure 2**).
4. Remove cowl vent by bowing upward in the center of the cowl vent and lift out. (**Figure 3**).
5. Remove the two screws (**H009**) retaining the cowl top inner panel shield. (**Figure 4**). Then remove shield by sliding shield toward middle of vehicle taking care not to damage the shield. (**Figure 5**).
6. Remove dirty cabin air filter. (**Figure 6**).
7. Reverse the procedure to install new cabin filter.



H006
cowl grille clip



H007
cowl grille screw



H008
cowl grille screw retainer



H009
filter splash guard screw



Figure 1



Figure 2



Figure 3



Figure 4



Figure 5



Figure 6



Application:

Buick Allure, Lacrosse, Century, Regal | Chevrolet Impala, Monte Carlo | Pontiac Grand Prix | Oldsmobile Intrigue (with automatic temperature control air conditioning)

Tools:

Standard Screwdriver

Location of cabin filter:

In front of the windshield under the cowl vent screen on the passenger side of the vehicle.

To remove existing filter:

1. Raise hood and turn off ignition switch when the windshield wipers are in the up position. **(Figure 1).**
2. Disconnect washer pump hose from fender rail and cowl screen. **(Figure 2).**
3. Reposition hood weather-strip from right side of vehicle (peel back half way to center).
4. Remove air inlet grill retainers **(H005 and H004).** **(Figure 3).**
5. Remove air inlet grill by bowing upward in the center of the inlet grill and lift out. **(Figure 4).**
6. Remove compartment air filter. **(Figure 5).**
7. Reverse procedures 2 thru 7 to install new filter.
8. Return windshield wipers to park position.



Figure 1



Figure 2



H004
push type cowl grille
retainer



H005
cowl grille
retainer



Figure 3



Figure 4



Figure 5

**Application:**

Cadillac Escalade | Chevrolet Silverado, Suburban, C3500, Avalanche, Tahoe | GMC Sierra, Yukon, Denali

Tools:

7mm & 9mm Socket

Location of cabin filter:

Under passenger side dash remove hush panel and behind access door.

To remove existing filter:

1. Locate and remove the hush panel (if equipped) under the passenger side dash panel.
2. After removal of the hush panel locate the filter access door.
3. Unclip the filter access door from the front of the housing.
4. Pivot door to the side to provide access to the filters.
5. Remove the front filter by pulling downward.
6. Slide the rear filter forward and remove by pulling downward.
7. Reverse the procedure to install the new filters.



**Application:**

Ford Freestar | Ford Windstar | Mercury Monterey

Tools:

Unknown or not required.

**Location of cabin filter:**

In front of the windshield under filter access cover on the passenger side of the vehicle.

To remove existing filter:

1. Release and open hood.
2. Remove cabin filter cover from along cowl vent screen on the passenger side of the vehicle. **(Figure 1).**
3. Remove filter by lifting straight up, then pull straight out through access door. **(Figure 2).**
4. When inserting new cabin filter into filter cavity, make sure that the edge with the foam rubber seal is facing down as shown in detail view. **(Figure 3).**
5. After cabin filter is placed into filter housing, gently press down on filter to insure that the seal is seated properly in filter housing. **(Figure 4).**
6. Reverse steps 1-5 to complete installation.



Figure 1



Figure 2



Figure 3



Figure 4

**Application:**

Dodge Caravan, Grand Caravan | Chrysler Pacifica, Town and Country, Voyager

Tools:

Unknown or not required.

Location of cabin filter:

Under the dash on the passenger side of the vehicle behind filter access door.

To remove existing filter:

1. Locate filter access cover and slide clip securing the filter cover forward (**Figure 1**) and remove cover (**Figure 2**).
2. Hold filter tightly and pull downward on the filter to remove dirty filter from the housing, bending filter at hinged area for ease of removal. (**Figure 3**).
3. Install new filter in housing paying close attention to air flow directional arrow on each side of the filter “shimmying” the new filter into filter housing. Bend as necessary at the hinged area for ease of installation.
4. Secure filter cover and clip.
5. Secure carpet in place.

**Figure 1****Figure 2****Figure 3**

**Application:**

Acura EL, RSX | Honda CRV, Civic, Element

Tools:

Unknown or not required.

Location of cabin filter:

Behind the glove compartment, behind an access door on the passenger side of the vehicle.

Removal of existing filter:

1. Open the glove compartment and locate and remove the hinge tabs on either side of the glove compartment. **(Figure 1, 2).**
2. Flip the glove compartment down and locate the access door. **(Figure 3).**
3. Open the access door to the right and remove. **(Figure 4).**
4. Remove the first filter and frame. **(Figure 5).**
5. Slide the second filter and frame to the left and remove. **(Figure 6).**
6. Remove the dirty filters from each frame and replace with clean filters in each frame according to the airflow direction arrows printed on the end of the filters. **(Figure 7).**
7. Reinstall both filters and frames into the filter housing.
8. Reattach the filter access door replace the hinge tabs and close the glove compartment.



Figure 1



Figure 2



Figure 3



Figure 4



Figure 5



Figure 6



Figure 7

**Application:**

Acura MDX | Honda Odyssey, Pilot

Tools:

Unknown or not required.

Location of cabin filter:

On the passenger side of the vehicle behind the glove compartment in the air conditioner evaporator assembly.

To remove existing filter:

1. Locate and remove the lower cover of the passenger side dashboard.
2. Locate and remove the lower cover located in the center of the dashboard.
3. Locate and remove the four screws at the bottom of the glove compartment.
4. Locate the hooks that secure the glove compartment, release the hooks by gently prying up on the cap.
5. To complete glove compartment removal, pull down on the striker and carefully disconnect the light connector.
6. Locate and remove the screws and bolt securing the glove compartment frame.
7. Locate and remove the filter cover and pull out the filter assembly.
8. Remove the dirty filter from the assembly and replace with clean filter.
9. Reinstall filter assembly and clean filter in housing.
10. Complete installation by reversing procedure



**Application:**

Ford Expedition, Pickup F150, F250, F350; Super Duty, F250, F350, F450, F550 | Lincoln Navigator, Blackwood

Dealer installed option (the vehicle must have dealer installed accessory kit F65Z 18D477 AA)

Tools:

Unknown or not required.

Location of cabin filter:

Under the dash behind the glove box assembly on the passenger side of the vehicle.

To remove existing filter:

1. Locate filter compartment lid under passenger side dash.
2. Remove five screws retaining the filter compartment lid.
3. Remove the filter compartment lid.
4. Slide the filter out of the compartment by the tab in the center of the filter.
5. Reverse procedure to install new filter.



**Application:**

Ford Escape | Mazda Tribute | Mercury Mariner

Tools:

Unknown or not required.

Location of cabin filter:

In front of the windshield under the cowl grille and the cabin filter housing cover on the passenger side of the vehicle.

To remove existing filter:

1. Turn off the ignition switch with the wipers in the vertical position.
2. With hood closed, gently remove the four plastic screw caps and screws at the base of the passenger side of the windshield retaining the cowl grille. **(Figure 1).**
3. Open the hood and remove the four plastic screw fasteners along the front edge of the cowl grille. **(Figure 2).**
4. Lift and hold open the cowl grille while disengaging the clips retaining the cabin filter housing cover and remove the cover by tilting the front edge up and pulling forward. **(Figure 3 & 4).**
5. When inserting the new filter into the filter cavity make sure the edge with the black rubber seal is facing down as shown in detailed view. **(Figure 5).**
6. After filter is placed into filter housing gently press down on the filter to insure that the filter is seated properly in the filter housing.
7. To complete installation reverse steps 1 thru 4.



Figure 1



Figure 2



Figure 3



Figure 4



Figure 5

**Application:**

Chevrolet Venture | Oldsmobile Silhouette | Pontiac Transport, Transport Montana

Tools:

Not required.

Location of cabin filter:

Inside of the glove compartment behind the air filter access door on the passenger side of the vehicle.

To remove existing filter:

1. Open the glove compartment door. **(Figure 1)**.
2. Inside the glove compartment: locate the removable panel on the left hand side of the glove compartment. **(Figure 2)**.
3. Pull out on the tab on the bottom of the panel to remove the panel as shown in **Figure 2** and **Figure 3**.
4. Located behind the panel is the filter access door. **(Figure 4)**.
5. Pull out on the latch on the left hand side of the filter access door and open the filter access door to the right as shown in **Figure 4**.
6. Remove the two filters from the filter compartment as shown in **Figure 5**.
7. Reverse procedure to install new filters.



Figure 1



Figure 2



Figure 3



Figure 4



Figure 5



Application:

Cadillac DeVille, Deville DHS, DTS

Tools:

Unknown or not required.

Location of cabin filter:

In front of the windshield under the filter access cover on the passenger side of the vehicle.

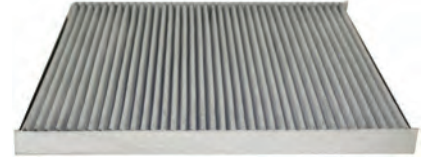

Removal of existing filter:

1. Release and open hood.
2. Locate and unsnap the filter cover located on the passenger side of the vehicle. **(Figure 1, 2).**
3. Open filter cover.
4. Locate the lever on the left side of the filter housing that retains the filter. Push the lever out and remove the filter. **(Figure 3, 4).**
5. Replace with a clean filter by pushing the lever on the filter housing out and sliding the clean filter into the housing as shown. **(Figure 5).**
6. Replace cover and close hood.



Figure 1



Figure 2



Figure 3



Figure 4



Figure 5



Application:

Buick LeSabre | Pontiac Bonneville

Tools:

Unknown or not required.

Location of cabin filter:

In front of the windshield under the filter access-cover on the passenger side of the vehicle.

Removal of existing filter:

1. Release and open hood.
2. Locate the cabin filter cover along the cowl vent screen on the passenger side of the vehicle.
3. Remove the cabin filter cover.
4. Lift up on the cabin filter and housing.
5. Install new filter and housing.
6. Complete installation by reversing steps 1-3.



**Application:**

Lexus GS300, GS400

Tools:

Unknown or not required.

Location of cabin filter:

Under the driver side dashboard on the side of the heater unit by the accelerator pedal behind the cabin filter access door.

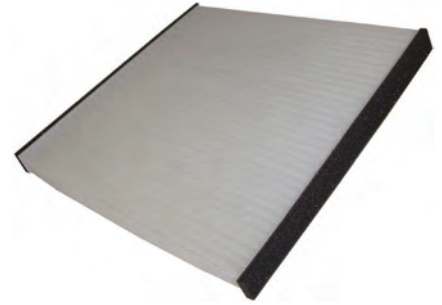
**Removal of existing filter:**

1. Pull the driver's side carpet (directly adjacent to the accelerator pedal) to expose the heater unit and cabin filter access door.
2. Locate the retaining tab on the top of cabin filter access door. Squeeze and pull out on the door and remove.
3. Remove the dirty cabin filter by pulling outward. Remove the second filter by pulling downward and then outward.
4. Install two new filters and complete installation by reversing the procedure.

**Application:**

Volkswagen Beetle, Cabrio, Golf III, Golf IV, Jetta, Passat | Audi TT, Quattro

Tools:

Phillips Screwdriver.

Location of cabin filter:

In front of the windshield under the cowl vent screen in the air intake box on the passenger side of the vehicle.

To remove existing filter:

1. Open Hood. **(Figure 1).**
2. Unscrew the plastic trim screws holding the cowl vent screen in place. **(Figure 2).**
3. Remove the sectional rubber cushion by raising and pulling back towards the middle of the vehicle. **(Figure 3).**
4. Remove the cowl vent screen. **(Figure 4).**
5. Open the retaining clips holding the filter frame in place. **(Figure 5).**
6. Remove the filter frame and used filter by lifting out of filter frame base. **(Figure 6).**
7. Insert the new filter in the filter frame by pushing the two ends of the filter frame into the outer pockets of the filter as shown in **Figure 7.**
8. To complete installation reverse steps 1 thru 5.



Figure 1



Figure 2



Figure 3



Figure 4



Figure 5



Figure 6



Figure 7

**Application:**

Toyota Corolla, Matrix

Tools:

Unknown or not required.

Location of cabin filter:

Behind the glove compartment, behind an access door on the passenger side of the vehicle.

Removal of existing filter:

1. Open the glove compartment and push in on the sides of the glove compartment and rotate glove compartment down.
2. Locate the cabin filter access door.
3. Open and remove the access door.
4. Remove the existing dirty filter.
5. Install new filter into the filter housing.
6. Reattach the filter access door.
7. Rotate glove compartment back into place by depressing in on sides and closing the compartment



**Application:**

Saturn LS, LW, L

Tools:

Standard Screwdriver

**Location of cabin filter:**

In front of the dash under the cowl vent screen on the passenger side of the vehicle.

To remove existing filter:

1. Raise Hood. **(Figure 1)**.
2. Remove sectional rubber cushion by raising and pulling back toward middle of vehicle. **(Figure 2)**.
3. Using a flat blade screwdriver, gently pry open (using an upward motion) the cowl to reveal the filter housing and element. **(Figure 3, 4)**.
4. Locate and unsnap (outward) the two tabs securing the cabin filter to the housing. **(Figure 5)**.
5. Remove the dirty filter **(Figure 6)** and install a new filter paying close attention to the airflow direction arrows.
6. Snap the tabs securing the filter to the housing inward making sure that the filter is properly secured.
7. Close the cowl cover and snap back into place (ensure that the cowl is secure).
8. Replace sectional rubber cushion.
9. Close hood.



Figure 1



Figure 2



Figure 3



Figure 4

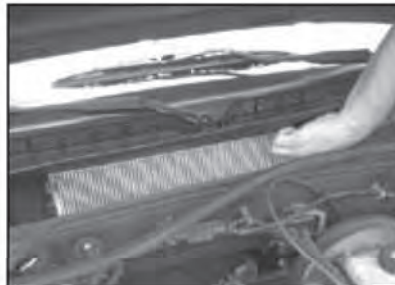

Figure 5

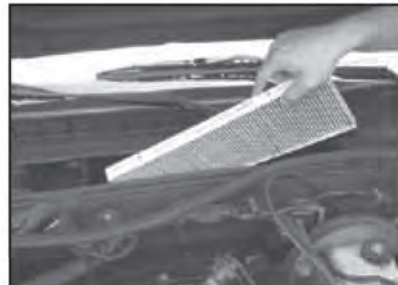

Figure 6



Application:

Chevrolet Equinox | Pontiac Torrent | Saturn Vue | Suzuki XL-7

Tools:

Flat head screwdriver

Location of cabin filter:

In front of the windshield under the cowl vent screen on the passenger side of the vehicle.

To remove existing filter:

1. Turn off ignition switch when the windshield wipers are in the up position. **(Figure 1).**
2. Raise hood. **(Figure 2).**
3. Remove the 4 push pins from the cowl cover. **(Figure 3).**
4. Lift cowl cover off and set aside. **(Figure 4, 5).**
5. Remove dirty cabin air filter and replace with new one. **(Figure 6, 7).**
6. Reverse steps 1-4 to complete installation.

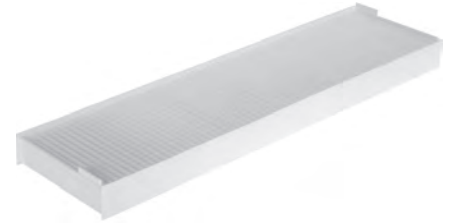

Figure 1



Figure 2



H012
push type cowl
grille retainer



Figure 3



Figure 4



Figure 5



Figure 6



Figure 7

**Application:**

Lexus ES350, GS300, GS350, GS430, GS450H, IS F, IS250, IS350 | Scion XD | Toyota Avalon, Camry, Highlander, RAV4, Tundra, Yaris

Tools:

Unknown or not required.

Location of cabin filter:

Under the dash on the passenger side of the vehicle behind the glove compartment.

**To remove existing filter:**

- *1. Set the air conditioning system to the RECIRCULATING mode. The air conditioning filter case CANNOT be removed with the system in the OUTSIDE AIR mode.
2. Turn the engine off.
3. Open the glove compartment.
4. Unclip the damper rod on the right side of the glove compartment. **(Figure 1).**
5. Push outward on both the front and rear of the glove compartment to disengage retainers and lower glove compartment. **(Figure 2 and 3).**
6. Through the glove compartment opening, locate the filter cover and remove.
7. Remove dirty filter and replace with clean filter.
8. Reverse steps 1-4 to complete installation.

*Step 1 pertains to Lexus GS and IS series.



Figure 1



Figure 2



Figure 3



Figure 4



Figure 5

**Application:**

Lexus ES330, GX470, RX350, RX400H, Toyota Avalon, Camry, Sienna, Solarao

Tools:

Phillips Screwdriver

Location of cabin filter:

Under the dash on the passenger side of the vehicle behind the glove compartment.

Removal of existing filter:

1. Open the glove compartment. **(Figure 1).**
2. Remove the screw securing the damper rod to the right side of the glove compartment. **(Figure 2).**
3. Push in on the sides of the glove compartment to disengage the retainers and lower glove compartment door. **(Figure 3).**
4. Through the glove compartment opening locate the filter housing and remove from the filter outlet. **(Figure 4 and 5).**
5. Remove dirty filter from the housing and replace with clean filter. **(Figure 6).**
6. Reverse steps 1-4 to complete installation.

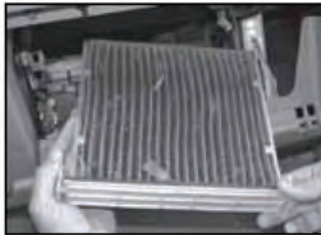
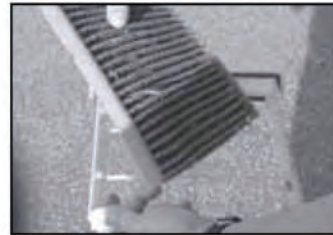
**Figure 1****Figure 2****Figure 3****Figure 4****Figure 5****Figure 6**

**Application:**

Nissan Sentra, Rogue

Tools:

Unknown or not required.

Location of cabin filter:

On driver side, inside the trim panel near the accelerator pedal, behind cabin filter cover.

To remove existing filter:

1. Locate and remove trim panel beside the accelerator panel.
2. Remove the cabin filter cover by pulling down on the clip securing it until it disengages.
3. Remove the dirty filter.
4. Install new filter with arrow printed on filter in up position.
5. Replace the cabin filter cover by hooking at the top and swing down and securing the clip in place.
6. Replace the trim panel.



**Application:**

Hyundai Azera, Santa Fe, Sonata, Magentis, Optima

Tools:

Unknown or not required.

Location of cabin filter:

Under the dash on the passenger side of the vehicle behind the glove compartment.

To remove existing filter:

1. Open glove compartment.
2. Unclip the damper rod on the right side of the glove compartment. On some models, it may be necessary to remove the panel to the right side of the glove compartment to remove the damper rod.
3. Push inward on both sides of the glove compartment to disengage retainers and lower glove compartment.
4. Through the glove compartment opening locate the filter cover and remove.
5. Remove dirty filter and replace with clean filter.
6. Reverse steps 1-4 to complete installation.



**Application:**

Chrysler PT Cruiser*

***Special note:** 2001 PT Cruisers do not have filter housing to install filter. On 2001 models the filter housing would have to be purchased from the dealer and installed on vehicle before filter can be installed. On all other models the housing should be in the vehicle but a filter may not be installed. On these vehicles you will just install a filter in the existing housing.

Tools:

Phillips-head screwdriver, possibly a flat blade screwdriver or blade; ratchet set or nut driver set.

Location of cabin filter:

Under the hood on the passenger side of the vehicle under the cowling.

**Removal of existing filter:**

1. Open hood and secure open using the prop rod on the right hand side of the vehicle.
2. Using the Phillips-head screwdriver, remove the 3 screw clips and bases from the passenger side cowling. **(Figure 1)**.
3. Using the Phillips-head screwdriver, remove the 1 screw and base on the left side of the passenger side cowling. **(Figure 2)**. You may need to gently pry the base loose with the flat blade screwdriver or blade.
4. Remove the rubber stop **(Figure 3)** on the left side of the cowling and pull up on the cowling to unclip it from the vehicle.
5. Slide the right side of the cowling out from under the driver side cowling to remove it **(Figure 4)**.
6. Using the proper size socket and ratchet or nut driver loosen the 2 bolts **(Figure 5)** on the left side of the washer fluid reservoir but do not remove them.
7. Using the proper size socket and ratchet or nut driver loosen the 1 bolt **(Figure 6)** on the right side of the washer fluid reservoir but do not remove it.
8. Tilt the reservoir forward to get to the cabin filter housing and remove the cover. **(Figure 7)**.
9. Remove the dirty filter if the vehicle has one; if not just install the new filter with air flow arrow printed on filter pointing towards the cab of the vehicle. **(Figure 8)**.
10. Reinstall the filter cover and make sure that the 2 tabs on the bottom of the cover **(Figure 9)** fit into the slots on the bottom of the housing and secure the cover at the top.
11. Tighten the 3 bolts on the right and left side of the washer fluid reservoir.
12. Reinstall the passenger side cowling making sure that the tabs on the top of the cowling fit into the slots on the vehicle under the windshield.
13. Make sure the cowling is completely seated and reinstall the rubber stop on the left side of the cowling.
14. The right side of the cowling slides under the driver side cowling to lock in place.
15. Tuck the front edge of the cowling under the weather stripping.
16. Reinstall the base on the left hand side of the cowling and then slide the screw into the base.
17. Reinstall the 3 bases along the front edge of the cowling and then slide the 3 screws into the bases.
18. Unhook the rod propping the hood open and secure back into position and close the hood.



Figure 1



Figure 2



Figure 3



Figure 4



Figure 5



Figure 6



Figure 7



Figure 8



Figure 9

**Application:**

Pontiac Vibe | Toyota Tacoma | Dodge Dart

Tools:

Unknown or not required.

Location of cabin filter:

Behind the glove compartment behind an access door on the passenger side of the vehicle

To remove existing filter:

1. Open the glove compartment and push in on the sides of the glove compartment and rotate glove compartment down.
2. Locate the cabin filter access door.
3. Remove the filter access door by lifting up on the two levers on the top edge of the cover.
4. Remove the existing dirty filter.
5. Install new filter.
6. Reattach the filter access door.
7. Rotate glove compartment back into place by depressing in on sides and closing the compartment

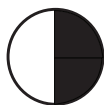

**Application:**

Nissan Altima 07-09

Tools:

Phillips screwdriver

Location of cabin filter:

Behind glove compartment; behind an access door on the passenger side of the vehicle.

To remove existing filter:

1. Open the glove compartment. **(Figure 1)**.
2. Remove the glove compartment assembly to access the blower assembly to the lower left. **(Figure 2)**.
3. Remove the access door to the filter by pulling downward on the clip and disengaging the snap **(Figure 3)**.
4. Remove the used filter by pulling on the pull tab on the side of the filter **(Figure 4)**.
5. Slide the new filter into the housing **(Figure 5)**.
6. Replace the access door by inserting the hook at the top first, then swing the bottom into place.
7. Reinstall the glove compartment assembly.



Figure 1



Figure 2



Figure 3



Figure 4



Figure 5

**Application:**

Nissan Pathfinder, Altima | Infiniti G20, QX4

Tools:

Unknown or not required

Caution or service label will be on glove box door if vehicle is equipped with cabin filter.

Location of cabin filter:

On the passenger side of the vehicle behind the glove compartment.

To remove existing filter:

1. With glove compartment closed, locate and remove the two screws at the bottom of the glove compartment securing the glove compartment frame to the dash panel.
2. Open the glove compartment and locate and remove the four screws at the top of the glove compartment securing the glove compartment frame to the dash panel.
3. Remove the glove compartment and assembly.
4. Locate and remove the screw securing the cabin filter cover and then remove the cover.
5. Remove the dirty cabin filters.
6. Replace the dirty filters by inserting the first clean filter in the housing and sliding to the right.
7. Insert the second filter in the housing and secure the cabin filter cover and screw.
8. To complete installation reverse steps 1-3.



**Application:**

Volvo C70, S60, S80, V70, XC70, XC90

Tools:

T25 Torx screwdriver

Location of cabin filter:

Beneath the trim panel under the glove compartment, behind the cabin filter panel cover on the passenger side of the vehicle

To remove existing filter:

1. Locate and remove the two T25 Torx screws securing the trim panel under the glove compartment and carefully snap out the trim panel and remove.
2. Locate and remove the four T25 Torx screws securing the cabin filter cover panel and remove that panel.
3. Slide the dirty filter from the filter housing and remove.
4. Replace with clean filter making sure that the narrow end of the filter is pointing upward.
5. Complete installation by replacing filter cover and screws, and panel trim and screws.

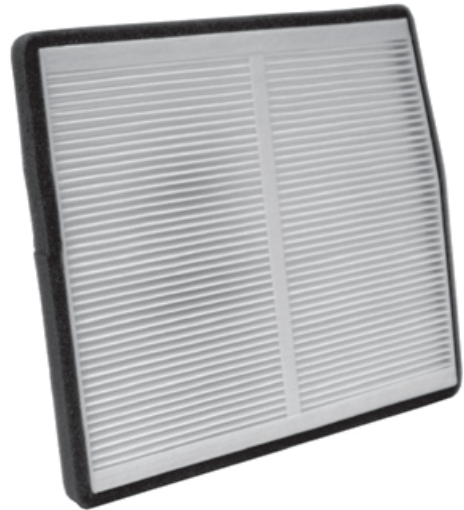

**Application:**

Nissan Frontier, Pathfinder and Xterra

Tools:

Unknown or not required.

Location of cabin filter:

Behind glove compartment, behind cabin filter access door on the passenger side of the vehicle.

To remove existing filter:

1. Open glove compartment.
2. Push in on both sides of the glove compartment door until the stop pins are clear of the glove compartment frame which allows the glove compartment door to swing completely downward.
3. Locate the cabin filter access door and unfasten the clasp securing the filter access door. Remove the door.
4. Remove the two dirty cabin filters and replace.
5. Reverse steps 1-3 to complete installation.



**Application:**

Toyota Echo, RAV4 | Scion TC, XA, XB

Tools:

Unknown or not required.

Location of cabin filter:

Under the dash on the passenger side of the vehicle behind the glove compartment.

To remove existing filter:

1. Open the glove compartment. **(Figure 1).**
2. To disengage the glove compartment, push in on each side of the glove compartment. Allow the glove compartment to swing downward. **(Figure 2).**
3. Locate the cabin filter housing and remove by pulling on the tabs on either side of the housing and remove. **(Figure 3, 4).**
4. Remove the dirty cabin filter from the housing (pay close attention to the flow direction of the filter in place in the housing). **(Figure 5).**
5. Place the new cabin filter in the housing (please make sure that the filter is placed in the housing with the same flow direction as the dirty filter). **(Figure 6).**
6. Reverse steps 1-3 to complete installation.

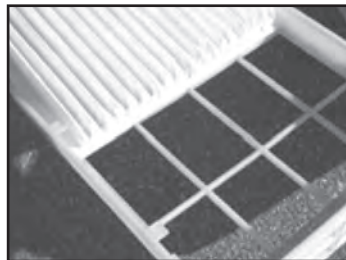
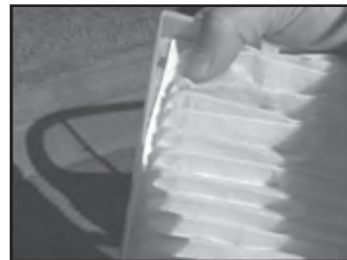
**Figure 1****Figure 2****Figure 3****Figure 4****Figure 5****Figure 6**

**Application:**

Cadillac CTS, SRX, STS

Tools:

Unknown or not required.

Location of cabin filter:

In front of the windshield under the cowl cover on the passenger side of the vehicle.

To remove existing filter:

1. Open hood and remove the weather stripping for the passenger side cowl cover.
2. Remove the 4 screws that secure the passenger side cowl cover.
3. Remove cowl cover.
4. Remove the pins that secure the filter cover and remove.
5. Remove the existing dirty filter.
6. Install new filter.
7. Reattach the filter access door and pins that secure it.
8. Replace passenger side cowl cover and secure with 4 screws.
9. Replace weather stripping and close hood.



**Application:**

Infiniti G35, M35 and M45

Tools:

Unknown or not required.

Location of cabin filter:

Behind glove compartment, behind cabin filter access door on the passenger side of the vehicle.

To remove existing filter:

1. Open glove compartment.
2. Locate and unclip the glove compartment hydraulic retaining device from the right hand side of the glove compartment.
3. Push in on both sides of the glove compartment door until the stop pins are clear of the glove compartment frame which allows the glove compartment door to swing completely downward.
4. Locate the cabin filter housing and remove by pulling on the tabs on either side of the housing and remove.
5. Remove the dirty cabin filter from the housing (pay close attention to the flow direction of the filter in place in the housing).
6. Place the new cabin filter in the housing (please make sure that the filter is placed in the housing with the same flow direction as the dirty filter).
7. Complete installation by reversing steps 1-4.



**Application:**

Mazda 3 and 5

Tools:

Unknown or not required.

Location of cabin filter:

Under the glove compartment on the passenger side of the vehicle.

To remove existing filter:

1. Remove the two panels under the glove compartment by unclipping the tabs securing the two panels (the top panel has two tabs and the side panel has one).
2. Find and remove the junction box by removing all harnesses connected to the box and unscrewing the two clips securing it.
3. Remove the bracket that held the junction box by unscrewing the nuts that secure it.
4. Find and remove the harness on the cabin filter access door.
5. Remove the cabin filter access door by removing the 4 screws securing it.
6. Remove the dirty filters and replace with clean filters making sure the foam is to the top of the filter marked "top" in the above picture and that filter is inserted in the top of the housing and the filter marked "bottom" is inserted in the bottom (just like the above picture).



**Application:**

Hyundai Tucson | Kia Rio and Sportage

Tools:

Unknown or not required.

Location of cabin filter:

Behind glove compartment, behind cabin filter access door on the passenger side of the vehicle.

To remove existing filter:

1. Open glove compartment.
2. Locate and unclip the glove compartment hydraulic retaining device from the right hand side of the glove compartment.
3. Push in on both sides of the glove compartment door until the stop pins are clear of the glove compartment frame which allows the glove compartment door to swing completely downward.
4. Locate the cabin filter housing and remove by pulling on the tabs on either side of the housing and remove.
5. Remove the dirty cabin filter from the housing.
6. Place the new cabin filter in the housing.
7. Complete installation by reversing steps 1-4.

Important: Re-install the hydraulic retaining device to the right side of the glove compartment.



**Application:**

Nissan Armada, Pathfinder, Titan | Infiniti QX56

Tools:

Unknown or not required.

Location of cabin filter:

On the passenger side of the vehicle behind the glove compartment.

Removal of existing filter:

1. With glove compartment closed locate and remove the two screws at the bottom of the glove compartment. **(Figure 1, 2, 3).**
2. Open the glove compartment and locate and remove the two upper glove compartment screws on either side. **(Figure 4, 5).**
3. Locate and remove the two lower screws on the glove compartment striker plate. **(Figure 6).**
4. Gently remove the glove compartment assembly.
5. Locate and remove the screw securing the cabin filter cover and then remove the cover. **(Figure 7, 8).**
6. Remove the dirty cabin filters. **(Figure 9).**
7. Replace the dirty filters by inserting the first clean filter in the housing and sliding to the right.
8. Insert the second filter in the housing and secure the cabin filter cover and screw.
9. To complete installation reverse steps 1-5.

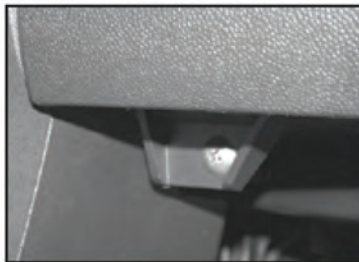

Figure 1



Figure 2



Figure 3



Figure 4

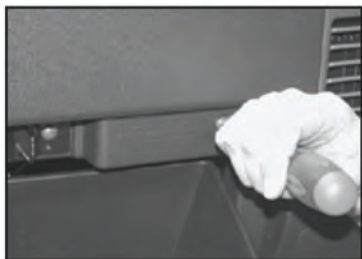

Figure 5



Figure 6



Figure 7



Figure 8



Figure 9



Application:

Ford Edge

Tools:

Unknown or not required.

Location of cabin filter:

Under the dash on the passenger side of the vehicle behind the glove compartment.

To remove existing filter:

1. Open glove compartment and release string hook on upper right hand corner of the glove compartment if your model has the string.
2. Push in on both sides of the glove compartment until the glove compartment comes forward and lift completely off.
3. Find the cabin filter access door and remove it.
4. Remove the dirty filter and replace with a clean filter.
5. Reverse steps 1-2 to complete installation.





Application:

Kia Spectra, Borrego

Tools:

Not required.

Location of cabin filter:

Behind glove box

To remove existing filter:

Spectra:

1. Open glove box. Lower the glove box down completely by removing the tension code (A) and the glove box stopper to the glove box (B). (Figure 1).
2. Remove the filter cover by pushing the knob. (Figure 2).
3. Replace the filter, install it after making sure of the direction of the air filter.
4. Reverse steps 1-2 to complete installation.

Borrego:

1. Open glove box. Lower the glove box down completely by removing the glove box stopper to the glove box (B). (Figure 3).
2. Remove the side damper (A) from the glove box (Figure 4).
3. Remove the filter cover by pushing the knob.
4. Replace the filter, install it after making sure of the direction of the air filter.
5. Reverse steps 1-3 to complete installation.

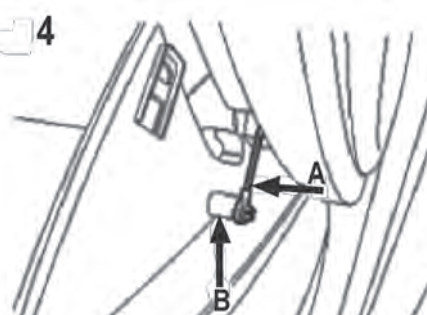
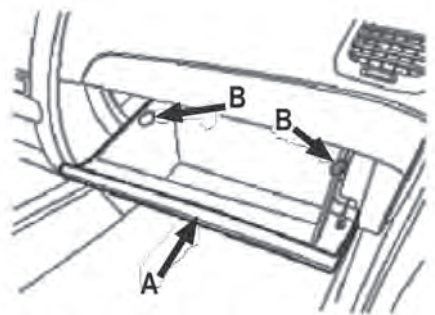
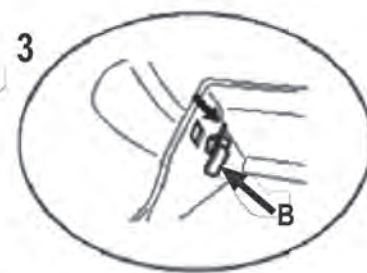
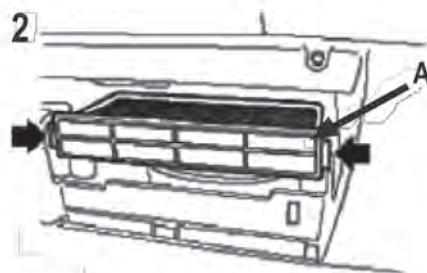
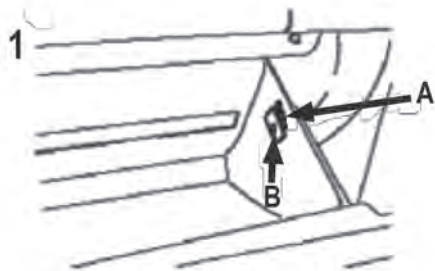



Application:

Hyundai Elantra

Tools:

Unknown or not required.

Location of cabin filter:

Under the dash on the passenger side of the vehicle behind the glove compartment.

To remove existing filter:

1. Open glove compartment.
2. Remove glove compartment clips.
3. Remove clip on right side glove compartment.
4. Pull down on filter cover and open.
5. Remove dirty filter and replace with clean filter.
6. Reverse steps 1-4 to complete installation.



**Application:**

Nissan Versa

Tools:

Unknown or not required.

Location of cabin filter:

Under the dash behind the glove compartment on the passenger side of the vehicle.

To remove existing filter:

1. Remove the glove compartment by unscrewing the 7 screws securing the glove compartment (3 at the top and 4 at the bottom).
2. Disconnect the electrical connector on the top of the glove compartment which will allow the glove compartment to be completely removed.
3. Remove the cabin filter access door by pulling on the tab at the top and pushing up slightly to release.
4. Remove the dirty filter by grabbing the tab on the filter and sliding to the right.
5. Replace with clean filter and complete installation by reversing steps 1-3.

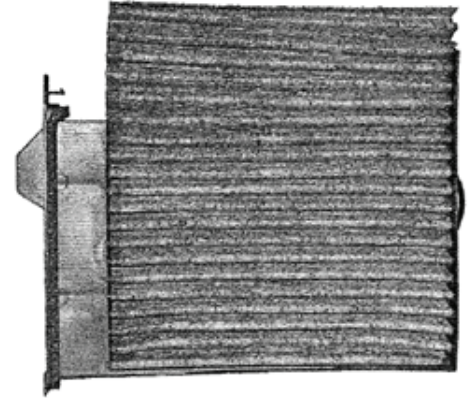

**Application:**

Kia Sorento

Tools:

Unknown or not required.

Location of cabin filter:

Behind glove box.

To remove existing filter:

1. Open glove box. Lower the glove box down completely by removing the glove box stopper **(B)** on the glove box **(A)**. (See **Figure 1**).
2. Remove the filter cover **(A)** by pushing the knob **(B)**. (See **Figure 2**).
3. Remove the dirty filter and replace with the clean filter.
4. Reverse steps 1-3 to complete installation.

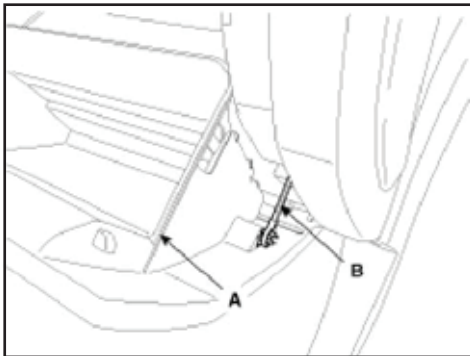

Figure 1

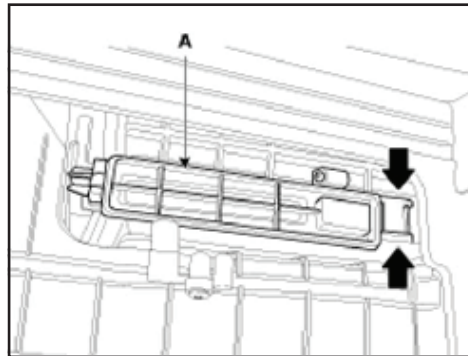

Figure 2



Application:
Hyundai Accent

Tools:
None required.

Location of cabin filter:
Behind glove box.

To remove existing filter:

1. Open the glove box.
2. Release glove box clips. **(See Figure 1).**
3. Remove filter cover. **(See Figure 2).**
4. Replace filter and repeat steps 1-3 in reverse order to complete. **(See Figure 3).**

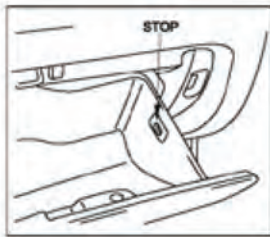

Figure 1

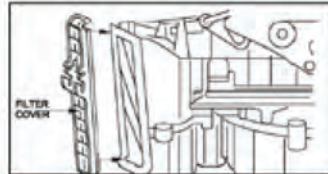

Figure 2

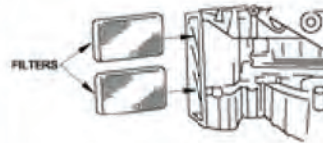

Figure 3

**Application:**

Subaru Forester, Impreza

Tools:

Unknown or not required.

Location of cabin filter:

On the passenger side of the vehicle behind the glove box.

To remove existing filter:

1. Open the passenger side door and open the glove box. Remove the retaining rod on the right hand side of the glove box.
2. Pull out on the glove box to disconnect the bottom hinges.
3. Look in the void left by the glove box and you will see the cabin filter cover.
4. Squeeze on the tabs securing the cabin filter cover and remove the cover and the filter.
5. Install the new filter and secure in place.
6. Re-engage the hinges on the bottom of the glove box.
7. Re-secure the retaining rod on the right of the glove box.
8. Close glove box.



**Application:**

Mini Cooper, Cooper S

Tools:

Unknown or not required.

Location of cabin filter:

Lower right hand side of the dash below the storage bin behind the cabin filter cover.

Removal of existing filter:

1. Locate the cabin filter cover on the lower right hand side of the vehicle beneath the storage bin and remove the 4 screws that secure it.
2. Remove the cover and unsnap the retaining clips securing the filter.
3. Remove the filter by pulling downward.
4. Replace with clean filter.
5. Reverse steps 1-3 to complete installation.

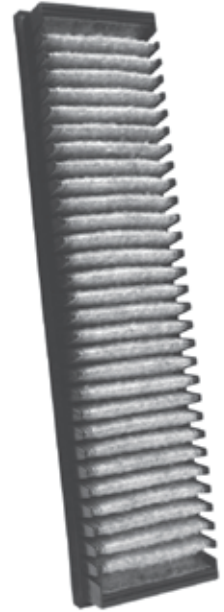

**Application:**

Hyundai Tucson

Tools:

None required.

Location of cabin filter:

Under dash on the passenger side of the vehicle behind the glove compartment.

**To remove existing filters:**

1. Open glove compartment and remove the support strap through the hole on right side of compartment.
 2. Lower the glove compartment completely by pushing in on the side of the glove compartment.
 3. Remove the cabin air filter cover by pressing the clips on both sides of the cover.
 4. Remove the cabin air filter by lifting it and replace with a new one.
 5. Reverse steps 1-3 to finish installation.
-

**Application:**

Mercedes E Class with 124 chassis

Tools:

Unknown or not required

Location of cabin filter:

Under the hood in front of the windshield in the center of the vehicle under the cowl vent.

To remove existing filter:

1. Open hood.
2. Remove the splash guard on the driver side of the vehicle.
3. Reposition the hood weather strip half way from the driver side of the vehicle.
4. Remove the four screws securing the cabin filter cover and remove the cover and two splash guards.
5. Unclip the clips securing the dirty filter and remove the dirty filters.
6. Replace with clean filters and secure in place with clips.
7. Complete installation by reversing steps 1-4.



**Application:**

Ford Fusion, Fusion Hybrid | Lincoln MKZ | Mercury Milan, Milan Hybrid

Tools:

Unknown or not required.

Location of cabin filter:

Behind the glove compartment.

To remove existing filter:

1. Open the glove box.
2. Push the side walls inward so the rubber stops clear.
3. Detach the retractable string by prying the tab outward. String will retract but it will be still accessible.
4. Pull box to the floor.
5. Insert a screwdriver in the two slots in each side of the access door and pull out. The right side of the door may need to be pulled downward to get past a non removable tubular part. The small vertical bolts you see are not a part of this process.
6. Reach in with your fingers, fold inward the paper tab at the top of the filter element on the right side and pull filter out. The filter needs to be pulled downward on the right side to get past the tubular part.
7. To insert the filter the right side tab again needs to be folded down and maneuvered past the tube.
8. Make sure the hinges at the bottom of the glove box have not detached.
9. Close the glove box, push the sides inward so the stops clear, reattach the retractable string, close the door.



**Application:**

Acura RL

Tools:

Unknown or not required.

Location of cabin filter:

Under the dash behind the glove compartment assembly on the passenger side of the vehicle.

Removal of existing filter:

1. Remove the glove compartment.
2. Remove the trunk opener main switch connector, the self-tapping screws and the glove compartment back cover.
3. Remove the filter lid.
4. Turn the ignition switch ON, and set the recirculation control switch on RECIRCULATE.
5. Pull the filter assemblies out of the recirculation housing. Separate the first filter assembly from the second filter assembly. Then remove the first filter assembly.
6. Remove the second filter from the recirculation housing.
7. Remove the filter from the filter housing.
8. Reverse the procedure to install new filter.
9. Make sure that there is no air leakage.

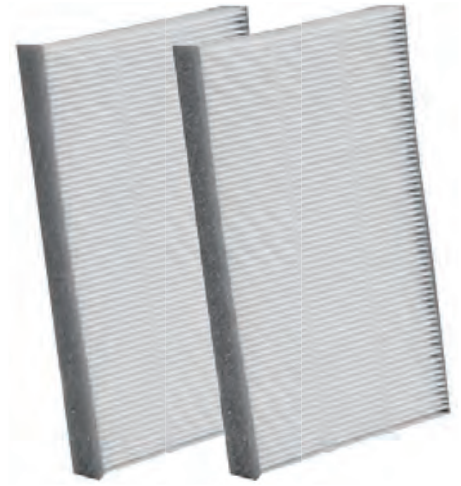

**Application:**

Honda Fit, Insight

Tools:

Unknown or not required.

Location of cabin filter:

Behind glove compartment, behind cabin filter access door on the passenger side of the vehicle.

To remove existing filter:

1. Open glove compartment.
2. Push in on both sides of the glove compartment door until the stop pins are clear of the glove compartment frame which allows the glove compartment door to swing completely downward.
3. Locate the cabin filter access door and unfasten the clasp securing the filter access door. Remove the door.
4. Remove the dirty cabin air filter and replace.
5. Reverse steps 1-3 to complete installation.



**Application:**

Hyundai | Genesis

Tools:

Unknown or not required.

Location of cabin filter:

Behind glove box.

To remove existing filter:

1. Open the glove compartment and remove the support rod. **(Figure 1).**
2. With the glove box open, remove the stoppers on both sides to allow the glove box to hang freely on the hinges. **(Figure 2).**
3. Remove the cabin air filter case by pulling out both sides of the cover. **(Figure 3).**
4. Replace the cabin air filter, making sure to note air flow direction.

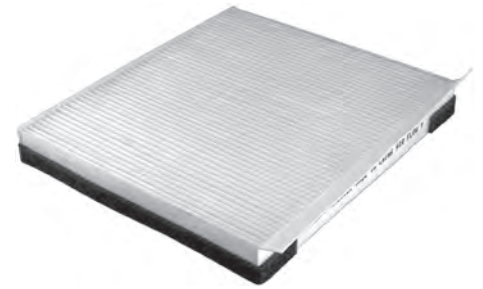

Figure 1



Figure 2



Figure 3

**Application:**

Acura RL, TL, TSX | Honda Accord, Civic, Ridgeline

Tools:

Unknown or not required.

Location of cabin filter:

Under the dash on the passenger side of the vehicle behind the glove compartment.

To remove existing filter:

1. Open the glove compartment and disconnect it by pushing forward on the stop on the right hand side of the glove compartment. Unhook the stop from the glove compartment. **(Figure 1, 2).**
2. Push in on both sides of the top of the glove compartment to disengage the retainers and lower the glove compartment allowing it to hang down. **(Figure 3).**
3. Remove the filter and filter frame. **(Figure 4, 5).**
4. Remove dirty filter from the frame and replace with clean filter.
5. Replace the filter frame with clean filter back in housing. **(Figure 6).**
6. Push in on the glove compartment sides and raise door into place.
7. Secure stop on right side of glove compartment and close glove compartment.



Figure 1

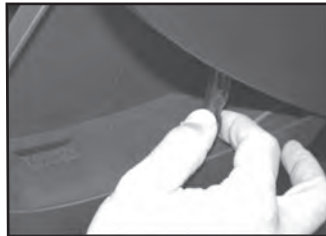

Figure 2



Figure 3



Figure 4



Figure 5

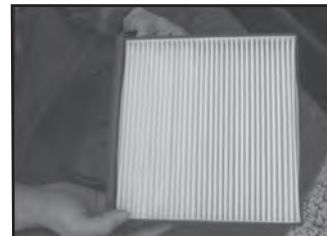

Figure 6

**Application:**

Mazda CX7

Tools required:

None.

Location of cabin filter:

Under dash on the passenger side of the vehicle behind the glove compartment.

To remove existing filters:

1. Open glove compartment and push in on sides to rotate the glove box down.
2. Push the dampener rod to the left until it clears the compartment. The glove compartment should come completely off. (See **Figures 1 & 2**).
3. Pull the door behind the glove compartment toward you. (See **Figure 3**).
4. Remove the dirty cabin air filter and replace with the new one. Reverse steps 1-3 to complete installation. (See **Figure 4**).

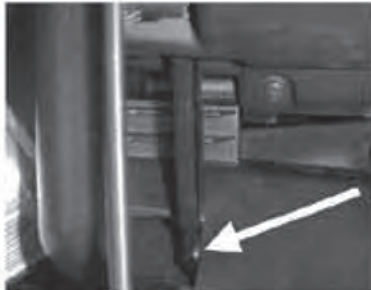
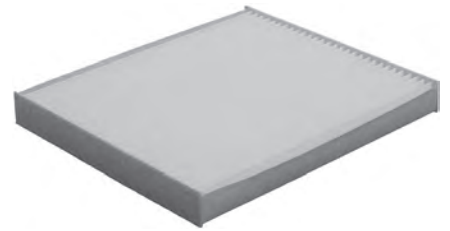

Figure 1

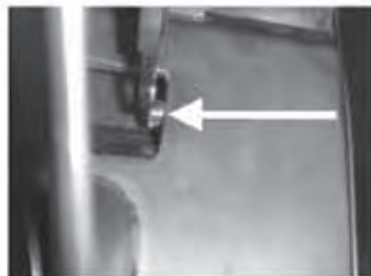

Figure 2



Figure 3



Figure 4

**Application:**

Chevrolet Cobalt, HHR Pontiac G5, Pursuit | Saturn Ion

Tools:

Unknown or not required.

Location of cabin filter:

Behind the glove compartment, behind the cabin filter access door on the passenger side of the vehicle.

To remove existing filter:

1. Open the glove compartment. **(Figure 1).**
2. Remove the rubber stops on each side of the glove compartment. **(Figure 2).**
3. Disengage glove compartment by pushing in on each side of the glove compartment until the glove compartment can swing downward completely. **(Figure 3 and 4).**
4. Locate the cabin filter door and raise the locking tab and open the door downward. **(Figure 5).**
5. Remove the dirty filter and replace with a new filter. **(Figure 6).**
6. Reverse steps 1-4 to complete installation



Figure 1



Figure 2



Figure 3



Figure 4



Figure 5



Figure 6

**Application:**

Hyundai Tiburon, Elantra, Entourage | Kia Sedona

Tools:

Phillips Screwdriver

Location of cabin filter:

Under the dash on the passenger side of the vehicle behind the glove compartment.

To remove existing filter:

1. Locate and remove the fixing pin on the right side of the glove compartment. **(Figure 1).**
2. Flip the glove compartment down by pressing firmly in on both sides of the glove box. **(Figure 2).**
3. Remove retaining bar covering the filter housing by removing the screws on either end. **(Figure 3).**
4. Open filter housing access door by pressing on both latches on bottom edge of door. **(Figure 4).**
5. Remove dirty filter by pulling straight out on handle and replace with clean filter. **(Figure 5).**
6. Reverse steps 1-5 to complete installation.

NOTE: Filter is keyed to ensure proper orientation. DO NOT FORCE.

Figure 1



Figure 2

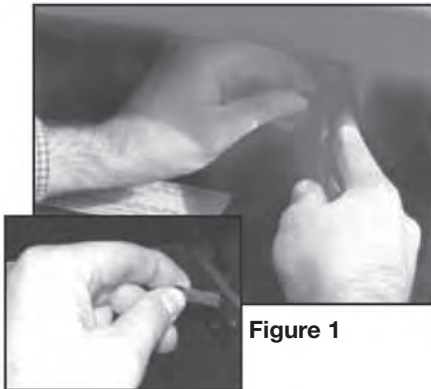

Figure 3



Figure 4



Figure 5

**Application:**

Lexus IS300, RX300 | Toyota Highlander

Tools:

Unknown or not required.

Location of cabin filter:

On the passenger side of the vehicle behind the glove compartment behind the cabin filter access panel.

To remove existing filter:

1. Open glove compartment and carefully press in on each side of the glove compartment allowing the stops to pull away and allow the glove compartment to swing down.
 2. Locate and remove the cabin filter door by pulling downward and towards you.
 3. Pull out dirty filter and housing.
 4. Remove dirty filter from housing by releasing the tabs to secure the filter to the housing.
 5. Replace filter in housing. Remember to secure filter to housing with tabs.
 6. Complete installation by reversing procedure.
-





Application:

Infiniti FX35, FX45, G35 | Nissan Altima, Maxima, Murano, Sentra

Tools:

Unknown or not required.

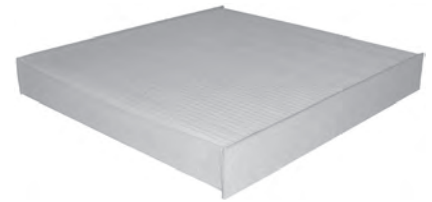

Location of cabin filter:

Under the dash behind the glove compartment on the passenger side of the vehicle.

A caution or service label will be on the glove box door if vehicle is equipped with a cabin filter.

To remove existing filter:

1. Locate and remove the two glove compartment lower hinge pins (**Figure 2**) by sliding outward from either side of the glove compartment. (**Figure 1**) See important note below.
2. Open the glove compartment and lower it out of the way.
3. Locate the cabin filter access door and unsnap the door and remove. (**Figure 3, 4**).
4. Remove the dirty filter and replace with clean filter. (**Figure 5**) (Please pay close attention to the air flow directional arrow when removing the dirty filter and installing the clean filter.)
5. Reverse steps 1 through 3 to complete installation.

Important note: On some models it may be necessary to remove the lower passenger panel and passenger side kick panel to remove the glove compartment. If this is the case:

- A. Remove the lower passenger panel by disconnecting the clips that secure it.
- B. Locate and remove the screw securing the passenger side kick panel to the floor and remove weather stripping on the kick panel. The kick panel can now be removed by pulling it away from the passenger door disconnecting the clips.
- C. For removal of the glove compartment in this case you will need to remove the 6 screws securing the glove compartment (4 at the top and 2 at the bottom). Continue the installation with step 3 at the top.



Figure 1



Figure 2

Please use caution and do not disconnect the yellow airbag connector or allow the glove box lid to hang by the yellow airbag wiring harness.



Figure 3



Figure 4



Figure 5

**Application:**

Dodge Caliber | Jeep Patriot, Compass

Tools:

None

Location of cabin filter:

Behind the glove compartment

To remove existing filter:

1. Open glove compartment
2. Squeeze sides of glove compartment to release past the stops. See **Figure 1**.
3. Remove the housing cover. See **Figure 2**.
4. Replace the old filter with the new one.
5. Repeat steps 1 - 3 to finish installation.

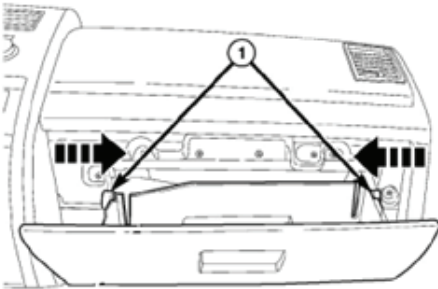

Figure 1

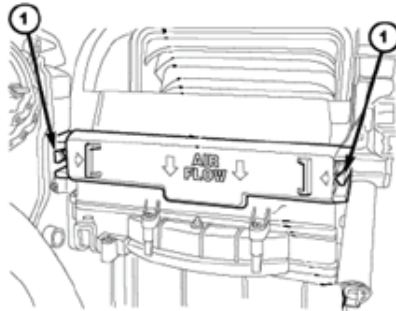

Figure 2



Application:
Mazda 6

Tools:
Unknown or not required.



Location of cabin filter:

Behind glove compartment, behind cabin filter access door on the passenger side of the vehicle

To remove existing filter:

1. Open glove compartment. **(Figure 1).**
2. Locate and unclip the glove compartment hydraulic retaining device from the right hand side of the glove compartment. **(Figure 2).**
3. Push in on both sides of the glove compartment door until the stop pins are clear of the the glove compartment frame which allows the glove compartment door to swing completely downward. **(Figure 3, 4).**
4. Locate the cabin filter access door and unfasten the clasp securing the filter access door. Remove the door. **(Figure 5, 6).**
5. Remove dirty filter as shown in **Figure 7** and replace with clean filter as shown in **Figure 7.**
6. Complete installation by reversing steps 1-4.

Important: Re-install the hydraulic retaining device to the right side of the glove compartment.



Figure 1



Figure 2



Figure 3



Figure 4



Figure 5



Figure 6



Figure 7



Figure 8

**Application:**

Kia Sorrento

Tools:

None required.

Location of cabin filter:

On the passenger side of the vehicle behind the glove box.

To remove existing filter:

1. Open the glove box and remove the two glove box stops on each side of the glove box. To remove the stops, twist them from the inside of the glove box and pull them out. **(Figure 1).**
2. Remove the glove box dampener cord on the right side of the glove box. **(Figure 2).**
3. Allow the glove box to swing down to the floor.
4. Unlatch and remove the cabin filter cover. **(Figure 3).**
5. Remove the dirty filter. **(Figure 4).**
6. Install the new filter.
7. Install the cabin filter cover and re-latch it.
8. Put the glove box back into position and reinstall the dampener cord to the right side of the glove box.
9. Partially close the glove box so you can reinstall the two glove box stops.
10. Close the glove box.



Figure 1



Figure 2



Figure 3



Figure 4

**Application:**

Hyundai Azera, Sante Fe, Sonata | Kia Optima

Tools:

Unknown or not required.

Location of cabin filter:

Under the dash on the passenger side of the vehicle behind the glove compartment

To remove existing filter:

1. Open the glove compartment.
2. Unclip the damper rod on the right side of the glove compartment. On some models it may be necessary to remove the panel to the right side of the glove compartment to remove the damper rod.
3. Push inward on both sides of the glove compartment to disengage retainers and lower glove compartment.
4. Through the glove compartment opening locate the filter cover and remove.
5. Remove dirty filter and replace with clean filter.
6. Reverse steps 1-4 to complete installation.



**Application:**

Dodge Durango and Jeep Grand Cherokee

Tools:

Standard screwdriver.

Location of cabin filter:

On the passenger side of the vehicle behind the glove box.

To remove existing filter:

1. Open the passenger side door. Open the glove box. **(Figure 1).**
2. Remove the dampener cord from the right hand side of the glove box **(Figure 2).**
3. Push in on each side of the glove box one side at a time until the glove box stops are disengaged. **(Figure 3).**
4. Once the stops are disengaged, allow the glove box to swing down towards the floor out of the way.
5. Carefully pull the glove box shelf from the instrument panel by carefully pulling it to you to disengage the 4 retainers **(Figure 4).**
6. Remove the cabin filter cover by disengaging the tab on the left and using a screw-driver to disengage the tab on the top in the middle. Remove the cover by opening it on its right side hinge and sliding the cover out from the hinge on the right side until it fully disengages. **(Figure 5).**
7. Remove the dirty filter by pulling it straight out **(Figure 6)** and replace it with a new filter.
8. Re-install the cabin filter cover by engaging the hinge on the right side and closing it and locking the tabs on top and left hand side.
9. Reinstall the glove box shelf.
10. Swing the glove box back into position and reinstall the dampener cord.
11. Re-engage the glove box stops.
12. Close the glove box.



Figure 1



Figure 2



Figure 3



Figure 4



Figure 5



Figure 6



Application:

Am General Hummer | Cadillac Escalade | Chevrolet Avalanche, Silverado | GMC Savana, Sierra, Yukon Denali XL

Tools:

Unknown or not required.

Location of cabin filter:

Under passenger side dash remove hush panel and behind access door.

To remove existing filter:

1. Locate and remove the hush panel under the passenger side dash panel.
2. After removing the hush panel, locate the filter access door.
3. Unclip the filter access door from the front of the housing.
4. Pivot door to the side to provide access to the filter.
5. Remove the dirty filter by pulling downward and replace with clean filter.
6. Complete installation by reversing steps 1-4.



**Application:**

Saturn Vue

Tools:

Phillips screwdriver.

Location of cabin filter:

Under the dash on the passenger side of the vehicle behind the glove compartment.

To remove existing filter:

1. Open glove compartment and remove the three screws securing the top of the assembly. **(Figure 1)**.
2. Close the glove compartment and remove the three screws securing the bottom of the assembly. **(Figure 2)**.
3. Gently pull outward on the glove compartment assembly until you release the three clips that secure it and the assembly aside. (The assembly is held in place by three metal clips - one on the left hand side and two on the right hand side.) **(Figure 3)**.
4. Locate the cabin filter door latches. Unlatch them and open door. **(Figure 4)**.
5. Remove dirty filter.
6. Replace with clean filter, close and latch cabin filter door. **(Figure 5)**.
7. Align the clips on the glove compartment assembly with the slots located on the frame surrounding the glove compartment and gently push into place.
8. With glove compartment open, align the holes and replace the top three screws.
9. Close glove compartment, align and replace the bottom three screws.



Figure 1



Figure 2



Figure 3



Figure 4



Figure 5

**Application:**

Chevrolet Camaro

Tools:

Unknown or not required.

Location of cabin filter:

In front of the windshield under the cowl cover on the passenger side of the vehicle.

To remove existing filter:

1. Open hood and remove the weather stripping for the passenger side cowl cover.
2. Remove the 4 screws that secure the passenger side cowl cover.
3. Remove cowl cover.
4. Remove the pins that secure the filter cover and remove.
5. Remove the existing dirty filter.
6. Install new filter.
7. Reattach the filter access door and pins that secure it.
8. Replace passenger side cowl cover and secure with 4 screws.
9. Replace weather stripping and close hood.

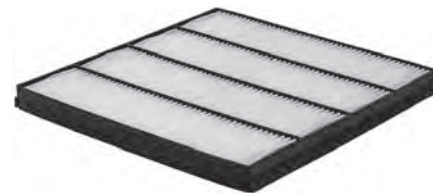

**Application:**

Chrysler 300, Dodge Challenger and Dodge Charger

Tools:

None

Location of cabin filter:

Under the hood on the passenger side of the vehicle.

To remove existing filter:

1. Open the hood.
2. Remove the panel from the passenger side cowl. **(Figure 1).**
3. Flip open the door on the top edge of the filter housing. **(Figure 2).**
4. Pull up on the old filter to remove it from the housing. **(Figure 3).**
5. Install the new filter into the housing with its airflow indicator arrow pointing towards the cab.
6. Close the door on the top edge of the housing.
7. Clip the panel back onto the passenger side cowl.



Figure 1



Figure 2



Figure 3

**Application:**

Buick LaCrosse

Tools:

Screwdriver.

Location of cabin filter:

Behind the glove compartment. Behind the access door on the passenger side of the vehicle.

To remove existing filter:

1. Open the passenger side door. Remove the end cover located on the side of the instrument panel in the top right corner. Remove the screw affixed to the side of the glove box.
2. Open the glove box door and remove the attached screws from around the glove box.
3. Lower the loosened glove box housing.
4. Unplug both wire cables and remove the glove box.
5. Pull the three tabs to release and open the filter door.
6. Remove the old air filter.
7. Install the new air filter.
8. Reinstall the air filter door. Reinstall the glove box.



**Application:**

Buick Enclave, Chevrolet Traverse, GMC Acadia and Saturn Outlook

Tools:

None.

Location of cabin filter:

Behind the glove box.

Removal of existing filter:

1. Open the glove box.
2. Unclip the dampener arm from the right side of the glove box. **(Figure 1)**.
3. Remove the two stops that secure the glove box by turning them counter clockwise. **(Figure 2)**.
4. Remove the glove box from its hinges.
5. Unclip the four tabs on the filter tray to remove it from the housing. **(Figure 3)**.
6. Install the new filter into the tray with the airflow indicator arrow pointing down. **(Figure 4)**.
7. Reinstall the tray and make sure it latches back onto the housing. **(Figure 1)**.



Figure 1

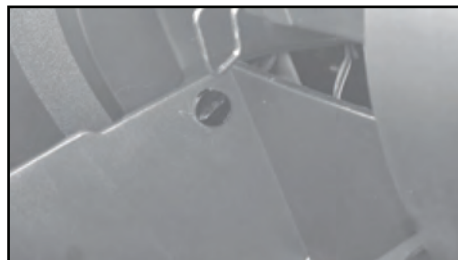

Figure 2



Figure 3

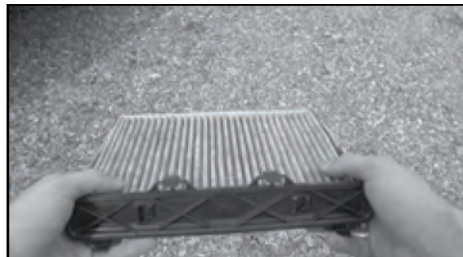

Figure 4

**Application:**

2013 Ford Escape

Tools:

7/64 Allen Wrench.

Location of cabin filter:

The filter is located under the glove box on the right side of the middle console.

To remove existing filter:

1. There is a cover under the glove box that must be removed to access the filter housing.
2. Squeeze the sides of the two screw clips to remove them from the cover. **(Figure 1).**
3. Pull down on the panel to remove it from the vehicle.
4. Using a 7/64 Allen Wrench remove the screw that secures the bottom of the housing cover to the housing. **(Figure 2).**
5. Push in on the two side clips to remove the filter housing cover. **(Figure 3).**
6. Pull out on the old filter to remove it from the housing. **(Figure 4).**
7. Pinch the middle of the new filter to maneuver it into the housing. **(Figure 5).**
8. Insert the new filter into the housing with its airflow indicator arrow pointing towards the cabin and make sure it expands back to fill the housing.
9. Clip the cover back onto the housing and make sure the tabs re-engage.
10. Reinstall the 7/64 screw that secures the housing cover to the housing.
11. Reinstall the bottom panel and attach the screw clips back onto the screws.



Figure 1



Figure 2



Figure 3



Figure 4



Figure 5

**Application:**

2013 Nissan Altima

Tools:

None.

Location of cabin filter:

Behind the glove compartment; behind an access door on the passenger side of the vehicle. **(Figure 1).**

To remove existing filter:

1. Remove the access door to the filter by pulling downward on the clip and disengaging the snap. **(Figure 2).**
2. Remove the used filter by pulling on the pull tab on the side of the filter. **(Figure 3).**
3. Slide the new filter into the housing.
4. Replace the access door by inserting the top first, then swing the bottom into place.

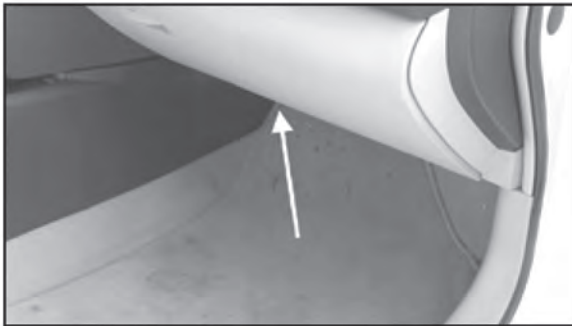

Figure 1



Figure 2



Figure 3

**Application:**

Mazda RX8, MPV

Tools:

Unknown or not required.

Location of cabin filter:

Under the dash behind the glove compartment on passenger side.

Removal of existing filter:

1. Locate slider on glove compartment door and release. **(Figure 1)**.
2. Push in on the sides of the glove compartment to disengage the retainers and lower glove compartment door. **(Figure 2)**.
3. Through the glove compartment opening locate the filter housing. Remove front cover of filter housing by pulling towards you. **(Figure 3)**.
4. Remove left filter first, followed by the right. **(Figure 4)**.
5. Remove the dirty filters from the filter housing and replace with clean filters.
6. Reverse steps 1-3 to complete installation.



Figure 1



Figure 2

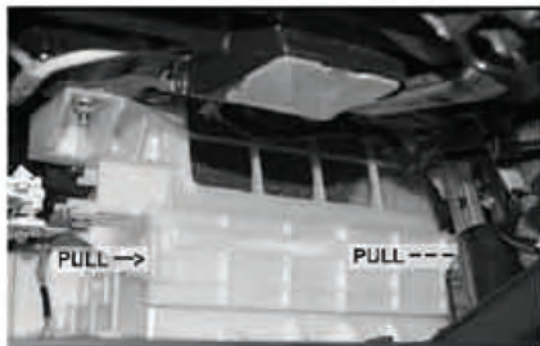

Figure 3



Figure 4

**Application:**

Dodge Nitro

Tools:

No tools necessary

Location of cabin filter:

Cabin filter located behind the glove compartment.

To remove existing filter:

1. Open glove compartment.
2. Press in on the sides of the glove compartment to release the stops and allow the glove compartment to hang down freely on its hinges. **(Figure 1)**.
3. Locate the cabin filter cover (straight ahead and slightly to the right). **(Figure 2)**.
4. Push out to release tabs on both sides of the cover and flip down. **(Figure 3)**.
5. Reach in and pull the first filter out, the second filter is to the right of the first filter, reach in and slide to the left align with opening and pull out. **(Figure 4)**.
6. The filter will have an air flow arrow on the side. Make sure the arrow is pointing down when installing. In the same location you pulled the dirty filter out, slide the first new filter all the way in and slide to the right. Then push in the second new filter. **(Figure 5)**.
7. Close the cover latch on both sides to secure.
8. Close the glove compartment door and the tabs will slide in place. You are done.



Figure 1



Figure 2



Figure 3

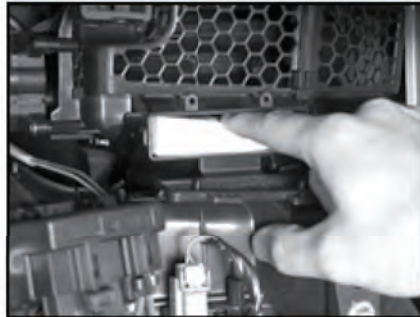

Figure 4



Figure 5

**Application:**

Mazda 3

Tools:

Phillips-head screwdriver

Location of cabin filter:

Under the dash on the passenger side of the vehicle.

To remove existing filter:

1. Look under the glove box and remove the plastic panel above the foot well. It is held in place by two clips nearest to the seat. The plastic panel may also have some lighting hooked to it, if so, un-clip that also.
2. Next pop out the center console panel. Do this by gently prying from the side closest to the shifter and slide it back towards the shifter once the clips are out.
3. Where you removed the center console panel, you should see the cabin filter cover. Remove the three Phillips-head screws securing the cover and remove the cover.
4. Remove the first filter by sliding the bottom filter out. Remove the second or top filter by sliding it out also.
5. Put the new filters in the housing so they stack like the filters you removed.
6. Replace the cabin filter door and replace the screws that secure it.
7. Replace the center console panel.
8. Replace the plastic panel above the foot well.



**Application:**

Nissan Maxima | Infiniti I30, I35

Tools:

Needle-nose pliers and a #2 Phillips Screwdriver

Caution or service label will be on glove box door if vehicle is equipped with cabin filter.

Location of cabin filter:

On the passenger side of the vehicle behind the glove compartment door.

To remove existing filter:

1. With glove compartment closed locate and remove the two screws and or the clips and lower glove compartment finisher located at the bottom of the glove compartment.
2. Open the glove compartment, locate and remove the four plastic screws at the top of the glove compartment frame including the screws securing the glove compartment latch.
3. Allow the glove compartment to swing downward and disconnect the glove compartment light by pushing in on the tab and removing.

DO NOT DISCONNECT THE YELLOW AIR BAG CONNECTORS FROM EACH OTHER OR ALLOW THE GLOVE COMPARTMENT TO HANG FROM OR STRESS THE YELLOW AIR BAG CONNECTION OR WIRES.

4. Do not disconnect the yellow air bag connectors, instead remove the whole connection assembly by squeezing the little plastic tabs securing the assembly to the bracket.
5. Locate the cabin filter cover and remove the cover by pushing down on the metal clip at the bottom of the cover until it pops off.
6. Remove the cabin filter cover by sliding the plastic cap up and remove the cover from the fixture at the top.
7. Remove the dirty filter.
8. Replace the dirty filter with the two filters making sure that the air flow directional arrows are in the correct direction and that the two filters stack in place correctly to replace the original filter.
9. Reverse steps 1-6 to complete installation.



**Application:**

2011-2014 Jeep Wrangler

Tools:

None

Location of cabin filter:

The cabin air filters come in a set and are located behind the glove box.

To remove existing filter:

1. Open the glove box.
2. Squeeze in on both sides of the glove box to lower it towards the floor.
3. Remove the glove box from its hinges to set it on the floor.
4. Un-clip the two tabs on the bottom of the two access doors to open them.
5. Remove the two old filters from the housing by pulling them straight out.
6. Install the two new filters into the housing with their airflow indicator arrows pointing down.
7. Clip the access doors back into place.
8. Hook the glove box back onto its hinges and close it to re-engage the stops.



**Application:**

Mazda 2

Tools:

Phillips-head screwdriver

Location of cabin filter:

On the passenger side of the vehicle beneath the glove box.

To remove existing filter:

1. The filter is located on the passenger side of the vehicle to the left of the floorboard.
2. Remove the four screws that secure the cover to the housing.
3. Remove the first filter.
4. Pull down the second filter and remove it.
5. Install the first new filter into the housing with its airflow indicator arrow pointing towards the cab and slide it up into the housing.
6. Install the second filter into the housing in the same orientation.
7. Line the housing cover back up to the housing and reinstall the four screws.



**Application:**

Ford Escape Hybrid, Mercury Mariner Hybrid

Tools:

None Required.

Location of cabin filter:

Rear cargo on the drivers side trim panel.

To remove existing filter:

1. Remove access panel.
2. Push the tabs that are located on each side of the filter cover while pulling gently to remove filter cover.
3. Install new filter.
4. Install filter cover (note arrows indicating top side).
5. Re-install the access panel into the trim panel.

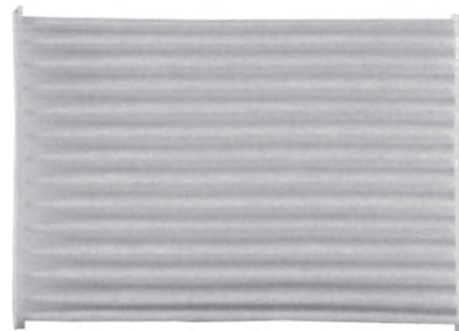

**Application:**

Ford Mustang

Tools:

Unknown or not required.

Location of cabin filter:

In front of the windshield on the passenger side of the vehicle under the cowl vent screen

To remove existing filter:

1. Open Hood.
2. Locate and remove the two screws (if present) securing the front of the cowl vent screen on the passenger side of the vehicle. **(Figure 1, 2).**
3. Carefully open the passenger side cowl vent screen by lifting the cowl straight up and releasing the four retaining clips. (Cowl may be secured by screws not clips.) **(Figure 3, 4).**
4. Holding the cowl out of the way, locate the cabin filter and remove. **(Figure 5).**
5. Remove filter from housing. **(Figure 6).**
6. Replace with clean filter and reverse steps to complete installation.



Figure 1



Figure 2



Figure 3



Figure 4



Figure 5

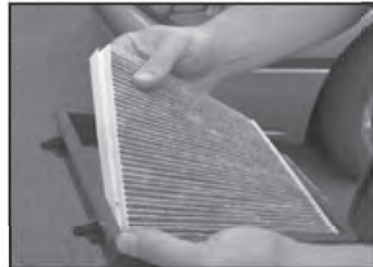
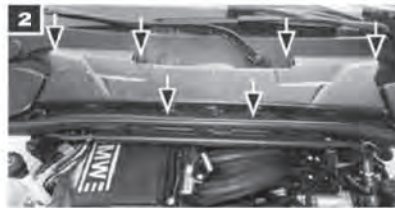

Figure 6



Application:
BMW 300 Series

Tools:
Unknown or not required.



**Application:**

Ford Escape | Mazda Tribute | Mercury Mariner

Tools:

Unknown or not required.

Location of cabin filter:

In front of the windshield under the cowl grille and the cabin filter housing cover on the passenger side of the vehicle.

To remove existing filter:

1. Turn off the ignition switch with the wipers in the vertical position.
2. With hood closed, gently remove the four plastic screw caps and screws at the base of the passenger side of the windshield retaining the cowl grille.
3. Open the hood and remove the four plastic screw fasteners along the front edge of the cowl grille.
4. Lift and hold open the cowl grille while disengaging the clips retaining the cabin filter housing cover and remove the cover by tilting the front edge up and pulling forward.
5. When inserting the new filter into the filter cavity make sure the edge with the black rubber seal is facing down.
6. After filter is placed into filter housing gently press down on the filter to insure that the filter is seated properly in the filter housing.
7. To complete installation reverse steps 1 thru 4.





Application:

Mercedes C Class (2011-2008)

Tools:

Standard screwdriver.

To remove existing filter:

1. Open the hood.
2. Open the three clips on the filter housing.
3. Remove the housing. Flip housing over and the filter is visible.
4. Disengage the filter from the housing and replace with a clean cabin air filter.
Replace the housing and relock the clips.



Figure 1



Figure 2



Figure 3



Figure 4

**Application:**

Volvo S80

Tools:25mm Torx bit
Screwdriver**Location of cabin filter:**

On the passenger side behind the lower left kick plate

**To remove existing filter:**

1. Move the passenger seat all the way back and remove all mats from the passenger floor.
2. Remove the left side kick plate. **(See Figure 1).**
3. Remove the two 25mm Torx screws holding the lower kick panel. **(See Figure 2).**
4. Remove the two screws holding the filter cover on the housing. **(See Figure 3).**
5. Draw out the filter element and replace with a new one. **(See Figure 4).**
6. Reverse steps 1-5 to complete.

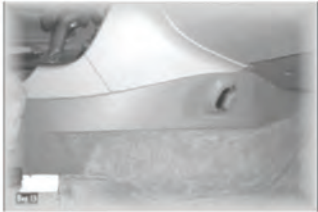

Figure 1



Figure 2



Figure 3



Figure 4

**Application:**

Suzuki Grand Vitara

Tools:

Unknown or not required.

Location of cabin filter:

Behind the glove compartment behind an access door on the passenger side of the vehicle.

To remove existing filter:

1. Open the glove compartment and push in on the sides of the glove compartment and rotate glove compartment down.
2. Locate the cabin filter access door.
3. Remove the filter access door.
4. Remove the existing dirty filter.
5. Install new filter.
6. Reattach the filter access door.
7. Rotate glove compartment back into place by depressing in on sides and closing the compartment.





Application:

Honda Fit

Tools:

Unknown or not required.

Location of cabin filter:

Under the dash on the passenger side of the vehicle behind the glove compartment.

To remove existing filter:

1. Open the glove compartment.
2. Push inward on both sides of the glove compartment to disengage retainers and lower glove compartment.
3. Through the glove compartment opening locate the filter cover and remove.
4. Remove dirty filter and replace with clean filter.
5. Reverse steps 1-3 to complete installation.



**Application:**

Mitsubishi Eclipse and Galant

Tools:

Not required.

Location of cabin filter:

Under the dash on the passenger side of the vehicle behind the glove compartment.

To remove existing filter:

1. Open glove compartment.
2. To disengage the glove compartment, push in on each side of the glove compartment. Allow the glove compartment to swing downward.
3. Locate the cabin filter housing and remove.
4. Remove the dirty cabin filter from the housing.
5. Place the new cabin filter in the housing.
6. Reverse steps 1-3 to complete installation.



**Application:**

Subaru Forester

Tools:

Phillips Screwdriver

**To remove existing filter:**

1. Using a phillips head screwdriver, remove the 9 screws holding the glove box in place.
2. Remove the filter cover as shown.
3. Remove the dirty filter and replace with the clean one making sure to note the arrow direction is pointed up.

Reverse steps 1 and 2 to complete installation.

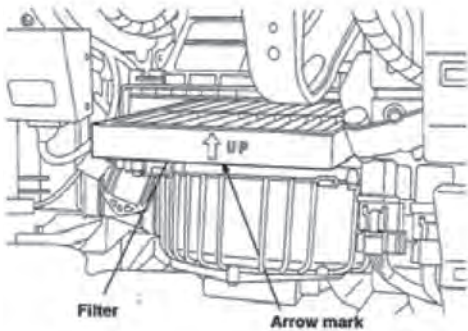
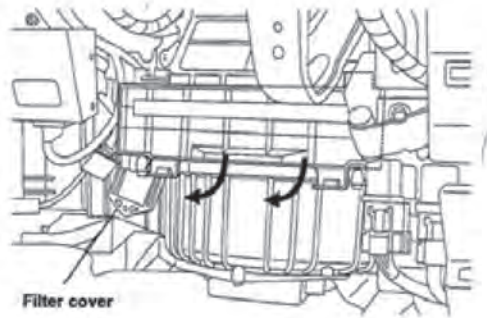
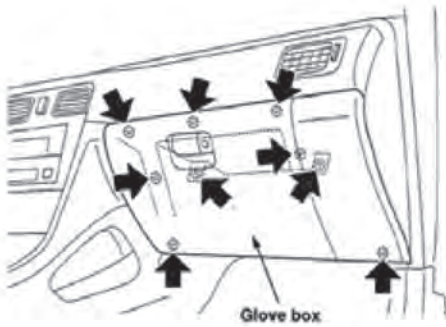

**Application:**

Kia Soul

Tools:

Phillips-head screwdriver.

Location of cabin filter:

On the passenger side of the vehicle behind the glove box.

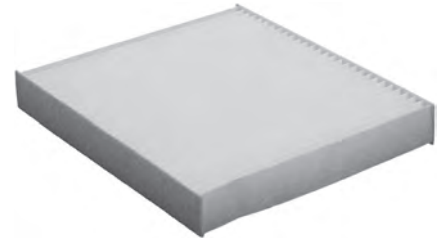
**To remove existing filter:**

1. Open the passenger side door and open the glove box.
2. Remove the 6 screws securing the glove box assembly and remove the assembly.
3. Locate the cabin filter cover and remove it.
4. Remove the dirty cabin filter and replace with new cabin filter.
5. Re-install cabin filter cover.
6. Re-position glove box assembly and re-install the 6 screws to secure it.
7. Close glove box.

**Application:**

Mazda 6

Tools:

None required.

Location of cabin filter:

Behind the glove box on the passenger side of the vehicle.

To remove existing filter:

1. Open the glove box and disconnect the dampener rod on the right side of the glove box. Disconnect the rod by pulling it towards the passenger side door.
2. Push in on both sides of the glove box until the glove box disengages from each side and the glove box can swing down on its bottom hinge.
3. Disengage the glove box completely from the dashboard.
4. Remove the cabin filter door.
5. Remove the dirty filter.
6. Install the clean filter.
7. Reinstall the cabin filter door.
8. Reengage the glove box to the dashboard.
9. Re-attach the dampener rod to the right side of the glove box.

(Caution – if the glove box is closed without being joined to the dampener rod, the dampener rod may be damaged. Verify that the dampener rod is joined to the glove box before closing the glove box).

10. Close the glove box.



**Application:**

Suzuki SX4

Tools:

Not required.

Location of cabin filter:

Under the dash on the passenger side of the vehicle behind the glove compartment.

To remove existing filter:

1. Open the glove compartment.
2. To disengage the glove compartment, push in on each side of the glove compartment. Allow the glove compartment to swing downward.
3. Locate the cabin filter housing and remove by pulling on the tabs on either side of the housing and remove.
4. Remove the dirty filter and replace with clean filter.
5. Reverse steps 1 through 3 to complete installation.



**Application:**

Ford Flex and Taurus | Lincoln MKS and MKT

Tools:

None required.

Location of cabin filter:

Under the dash on the passenger side of the vehicle behind the glove compartment.

To remove existing filter:

1. To remove the glove box, there are two hinge pins (**Figure 1**) that must be removed from the bottom of the glove box. Pull the pins towards the center of the glove box to remove them.
2. Open the glove box.
3. There is a dampener cord on the left side of the glove box that must be released. (**Figure 2**) Pull down on the dampener cord to free it from the glove box, then push from the inside of the glove box to release it.
4. Pull up on the glove box to remove it from its hinges and set it aside. (**Figure 3**).
5. Unhook the tabs at the bottom of the cabin filter housing cover to remove it. (**Figure 4**).
6. Remove the old filter from the housing by pulling it straight out. (**Figure 5**).
7. Insert your new filter into the housing with its airflow indicator arrow pointing down.
8. Reinstall the filter cover by hooking the top tabs into the housing and latching the bottom tabs.
9. Pull the dampener cord out so that you can reconnect it to the glove box.
10. There are three hooks on the bottom edge of the glove box that hook onto three tabs on the bottom of the assembly. Re-hinge the glove box and make sure it is completely secured to the assembly.
11. Close the glove box.
12. Reinstall the two hinge pins on the bottom of the glove box.



Figure 1



Figure 2



Figure 3



Figure 4

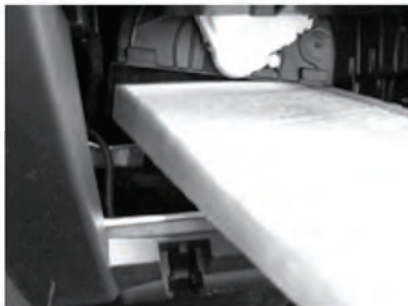

Figure 5

**Application:**

Fiat 500

Tools:

T-25 Torx wrench, standard screwdriver, 7/32 socket and ratchet

Location of cabin filter:

On the passenger side of the vehicle behind the kick panel on the center console.

Removal of existing filter:

1. Open the passenger side door and use your T-25 Torx driver. Remove the screw securing the kick panel to the center console. **(Figure 1)**.
2. Remove the panel from the vehicle by un-clipping it. **(Figure 2)**.
3. Using a flat-head screwdriver, remove the push clips from the panel that is below the glove box. **(Figure 3)**. The push clips have a groove that the screwdriver fits into. Remove the bottom panel from the vehicle.
4. Disconnect the electrical connector that hangs in front of the housing by un-clipping the back. **(Figure 4)**.
5. The housing cover has two screws that must be removed. **(Figure 5)**. Use your 7/32 ratchet to remove the two screws that hold the housing cover in place. Remove the housing cover.
6. Remove the old filter by pulling it out of the housing top first. **(Figure 6)**
7. Install your new cabin filter into the housing. The filter will fit snugly into the housing.
8. Reinstall the housing cover and the two screws that secure it.
9. Reconnect the electrical connector.
10. Place the panel you removed from the bottom of the glove box back into the vehicle and make sure it sits on top of the foot panel frame.
11. You must reset the clips before using them to secure the panel. Reinstall the two push clips that secure the panel to the vehicle.
12. Reinstall the kick panel to the center console. It has a tab at the bottom that hooks a screw near the front of the vehicle and a tab on the side that snaps the vehicle. The tab is at the top that slides into the frame and two tabs that snap the closest part of the panel to the vehicle.
13. Reinstall the screw that secures the panel to the vehicle using a T-25 Torx driver.

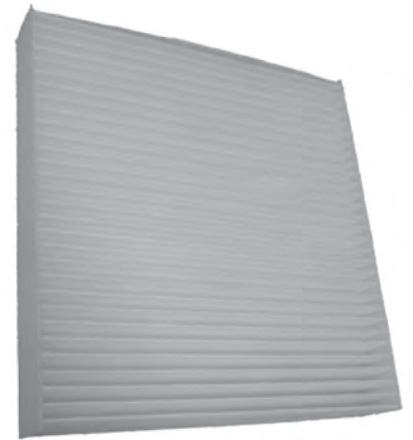

Figure 1



Figure 2



Figure 3



Figure 4



Figure 5



Figure 6

**Application:**

Honda CR-V, Insight

Tools:

Unknown or not required.

Location of cabin filter:

Under the dash on the passenger side of the vehicle behind the glove compartment in the evaporator assembly

Removal of existing filter:

1. Locate and remove the dashboard center and lower covers.
2. Locate and remove the four screws that secure the glove compartment back cover.
3. Remove the back cover.
4. Removal of the glove compartment frame is necessary to access the cabin filter cover. Remove the frame by releasing the hooks and pulling downward on the striker. Disconnect the glove compartment light connection and remove the bolt and screws that are securing the frame.
5. Remove the frame.
6. Locate the cabin filter cover on the evaporator assembly and remove.
7. Remove the filter assembly by pushing on the tabs that secure the assembly and pulling outward.
8. Remove the dirty filter from the frame and replace with a clean filter.
9. Reverse steps 1-7 to complete installation.

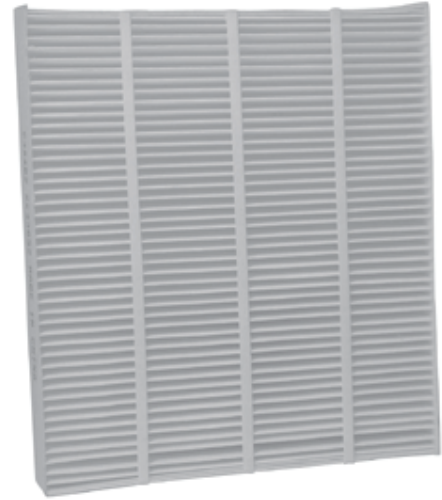

**Application:**

Audi A6, Quattro

Tools:

Unknown or not required.

Location of cabin filter:

The filter is located on the right under the cover of the heater fan.

**Removal of existing filter:**

1. Remove the windshield wiper arms.
2. Remove the four mounting screws from the cowl trim.
3. If necessary, remove the battery holder and push the battery in the direction of the wing or remove (depending on battery size).
4. Raise clamp A and remove filter B from adapter.
5. Insert new filter and reverse procedure to complete installation.

Important note: To prevent water from running onto the filter, make sure when re-installing the cover that the cover is not damaged and is properly mounted.



Application:

Audi A4, A4 Quattro, A6, A6 Quattro, Allroad Quattro, RS4, RS6, S4, S6

Tools:

Unknown or not required.

Location of cabin filter:

In front of the windshield under the cowl vent screen on the passenger side of the vehicle.

Removal of existing filter:

1. Open hood.
2. Remove sectional rubber cushion on the passenger side of the vehicle by raising and pulling back toward the middle of the vehicle.
3. Locate the cabin filter cover and remove by pulling up and sliding out.
4. Locate and unclip the retaining clip securing the filter in place.
5. Remove the dirty filter and replace with clean filter.
6. Reverse steps 1-4 to complete installation.





Application:

Ford Thunderbird | Jaguar S-Type | Lincoln LS

Tools:

Flat head screwdriver

Location of cabin filter:

In front of the windshield on the passenger side of the vehicle under the cowl vent screen.

Removal of existing filter:

1. Open hood.
2. Locate the six push type (H011) retainers securing the cowl vent screen on the passenger side of the vehicle. Push in on the center of the retainer and remove. **(Figure 1, 2).**
3. Carefully remove the passenger side cowl vent screen. **(Figure 3).**
4. Locate the cabin filter and unclip hooks on either side securing filter in place and remove dirty cabin filter. **(Figure 4).**
5. Replace with clean cabin filter and reverse steps to complete installation. **(Figure 5).**



H011
push type cowl
grille retainer

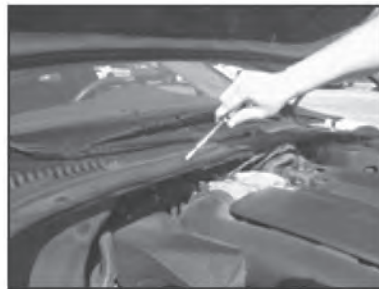

Figure 1



Figure 2



Figure 3

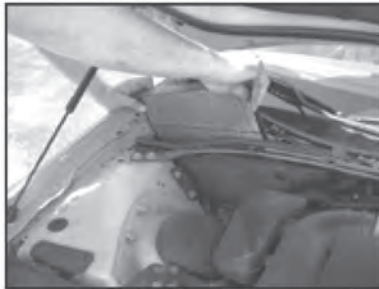

Figure 4



Figure 5

**Application:**

BMW 525i, 528i, 528iT, 530i, 540i, 540iT, M5

Tools:

Unknown or not required.

Location of cabin filter:

On the passenger and driver side of the vehicle under two filter cover panels in the cowl vent screen.

To remove existing filter:

1. Open hood and locate the two filter covers on either side of the vehicle (they are in front of the windshield in the cowl vent cover).
2. Unhook the wire latch located on the front of the filter cover by pulling forward.
3. Lift open the cover and carefully clean debris from the housing.
4. Remove dirty filter and install clean filter.
5. Repeat 2-4 on the other side of the vehicle.
6. Replace and secure filter covers.
7. Close hood.

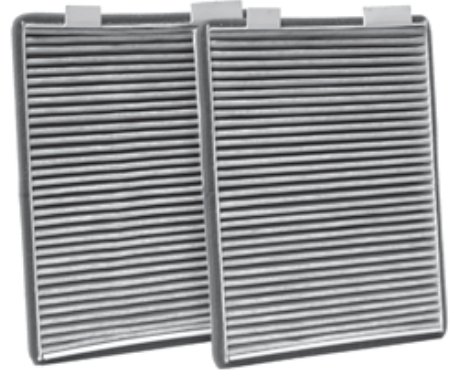

Figure 1



Figure 2



Figure 3



Figure 4



Figure 5

**Application:**

Lexus LS430, GS430, GS300, SC430

Tools:

Unknown or not required.

Location of cabin filter:

Behind the glove compartment, behind the cabin filter access door on the passenger side of the vehicle.

To remove existing filter:

1. Open glove compartment and locate the mini-shock or cable located on the right side of the glove compartment.
2. Remove the mini-shock or cable and push in on both sides of the glove compartment to release the glove compartment stops and swing the glove compartment downward.
3. Locate and remove the cabin filter access door by pushing in on the clips on both sides of the door.
4. Remove the dirty filter and replace with clean filter.
5. Reverse steps 1 thru 4 to complete installation.



**Application:**

Ford Thunderbird | Lincoln LS from 2002 | Jaguar S Type

Tools:

Standard screwdriver

Location of cabin filter:

On the passenger side of the vehicle in front of the windshield under the cowl vent screen.

To remove existing filter:

1. Open hood and locate the leaf screen panel on the passenger side of the cowl.
2. Using a standard screwdriver locate and pop out the six snap-on fasteners that secure the panel in place. Please note that one of the fasteners is located on the upper left side of the panel near the base of the hood hinge.
3. Once all fasteners are removed gently remove the leaf screen.
4. Unlatch and open the hinged lid under the panel.
5. The dirty filter is now visible remove the dirty filter and replace with clean filter.
6. Complete installation by reversing the procedure.



**Application:**

2002-2003 Lexus ES300 | Lexus ES300, GX470, RX330

Tools:

Unknown or not required.

Location of cabin filter:

Behind the glove compartment in the cabin filter housing

To remove existing filter:

1. Open the glove compartment.
2. Locate and remove the screw securing the glove compartment brace.
3. Locate and remove the glove compartment stops and lower the glove compartment.
4. Locate and remove the cabin filter housing and remove filter and housing.
5. Remove dirty filter from housing, pay close attention to the position of the filter.
6. Place clean filter in housing.
7. Reverse steps 1-4 to complete the installation.



**Application:**

Suzuki Grand Vitara and XL-7

Tools:

Unknown or not required.

Location of cabin filter:

Behind glove compartment, behind cabin filter access door on the passenger side of the vehicle.

To remove existing filter:

1. Open glove compartment.
2. Locate and unclip the glove compartment hydraulic retaining device from the right hand side of the glove compartment.
3. Push in on both sides of the glove compartment frame which allows the glove compartment door to swing completely downward.
4. Locate the cabin air filter housing and remove by pulling on the tabs on either side of the housing and remove.
5. Remove the dirty cabin filter from the housing.
6. Place the new cabin filter in the housing.
7. Complete installation by reversing steps 1-4.



Important: re-install the hydraulic retaining device to the right side of the glove compartment.

**Application:**

Audi A3 | Volkswagen EOS, Jetta, Passat

Tools:

Standard screwdriver.

Location of cabin filter:

Under the dash behind the glove compartment on the passenger side of the vehicle.

To remove existing filter:

1. Locate the panel covering the cabin filter access door under the passenger side dash.
2. Locate and remove the two screws securing the panel.
3. Locate the cabin filter access door.
4. Pull the center console trim piece that is covering the cabin filter access door down.
5. Open the cabin filter access door and remove.
6. Pull out dirty filter by the center of the filter.
7. Install clean filter.
8. Complete installation by reversing steps 1-5.





Application:

Hyundai Accent

Tools:

Unknown or not required.

Location of cabin filter:

Under the dash on the passenger side of the vehicle behind the glove compartment.

To remove existing filter:

1. Open glove compartment.
2. Remove the two clips on the inside of the glove compartment to allow the glove compartment to swing downward.
3. Locate and remove the cabin filter access panel.
4. Remove the dirty filter and replace with clean filter.
5. Reverse steps 1-3 to complete installation.

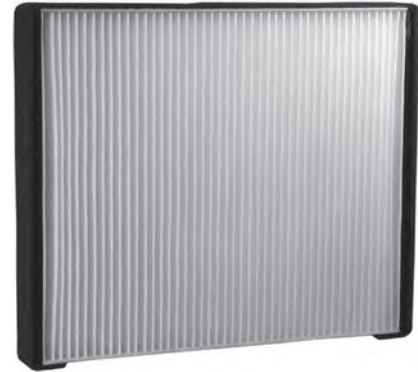

**Application:**

Hyundai Sonata, Santa Fe, Grandeur XG, Trajet and Optima

Tools:

Unknown or not required.

Location of cabin filter:

Under the dash on the passenger side of the vehicle behind the glove compartment.

To remove existing filter:

1. Open glove compartment.
2. Remove the three clips on the inside of the glove compartment to allow the glove compartment to swing downward.
3. Locate and remove the cabin filter access panel.
4. Remove the dirty filters and replace with clean filters.
5. Reverse steps 1-3 to complete installation.





Application:

Dodge Sprinter Van, Mercedes Sprinter, Volkswagen Crafter

Tools:

Not required.





Application:

Hyundai Veracruz

Tools:

None.

Location of cabin filter:

Behind glove compartment.

To remove existing filter:

1. Open glove compartment.
2. Remove glove compartment clips to access filter case.
3. Remove filter case.
4. Replace filter and repeat steps 1-3 in reverse order to complete installation.



Figure 1



Figure 2



Figure 3



Figure 4

**Application:**

Subaru Baja, Legacy, Outback

Tools:

Standard and Phillips screwdriver.

Location of cabin filter:

Under the dash on the passenger side of the vehicle behind the glove compartment.

To remove existing filter:

1. Open glove compartment and push in on both sides of the glove compartment until the glove compartment retainers are disengaged and the glove compartment can swing downward.
2. Locate and remove the glove compartment installation screws.
3. Remove the passenger side console side panel located left of the glove compartment.
4. Locate and disconnect the glove compartment light harness and remove the glove compartment assembly. Remove the glove compartment retainers and save for later reinstallation.
5. Locate and disconnect the resistor connector found on the cabin filter cover.
6. Insert the tip of a standard screwdriver into the top of each of the four clips securing the cabin filter cover and remove the clips by gently prying loose. (Make sure that the screwdriver is inserted into the top of the clip. Do not insert the screwdriver in the middle of the clip.)
7. Remove the cabin filter cover.
8. Remove the upper and lower filter. (Pay close attention to which filter was upper and which filter was lower).
9. Install the upper filter first. (Make sure the arrow molded in the end of the frame is pointing up.)
10. Install the lower filter. (Make sure the arrow molded in the end of the frame is pointing up. Also ensure the filter frame tongue and grooves fit properly in the matching tongue and grooves in the filter housing and matching filter frame tongue and grooves.)
11. Reverse steps 1-7 to complete installation.

Check the filter cover once installed to ensure that it is properly closed without the chance for air leaks. Reconnect the resistor connector and glove compartment light harness. Make sure that the glove compartment retainers are properly inserted in the glove compartment.



**Application:**

Chevrolet Aveo, Pontiac Wave

Tools:

Unknown or not required.

Location of cabin filter:

Under the dash on the passenger side of the vehicle behind the glove compartment

To remove existing filter:

1. Open the glove compartment.
2. Push inward on both sides of the glove compartment to disengage retainers and lower glove compartment.
3. Through the glove compartment opening locate the filter cover and remove.
4. Remove dirty filter and replace with clean filter.
5. Reverse steps 1-3 to complete installation.



**Application:**

Mitsubishi Lancer, Outlander

Tools:

Screwdriver.

Location of cabin filter:

Under the dash on the passenger side of the vehicle behind the glove compartment.

To remove existing filter:

1. Open the glove compartment
2. To disengage the glove compartment, push in on each side of the glove compartment. Allow the glove compartment to swing downward.
3. If vehicle is equipped with cabin filter unscrew the two screws on opposite corners and remove dirty filter and replace with clean filter.
4. Complete installation by reversing steps 1-2.



**Application:**

Cadillac Catera

Tools:

Unknown or not required.

Location of cabin filter:

In front of the windshield under the cowl vent screen on the passenger side of the vehicle.

**To remove existing filter:**

1. Open hood
2. Lift the engine compartment rear seal and pull it back far enough to be able to lift and open the grill flap.
3. Unhook both retaining clips that secure the filter in place.
4. Slide the filter toward the front of the car and then pull the filter straight out.
5. Reverse procedure to install new filter.

**Application:**

Mercedes-Benz C250, C300, C350, C63AMG and GLK350

Tools:

Not required.

Location of cabin filter:

Under the dash on the passenger side of the vehicle behind filter access door.

To remove existing filter:

1. Look under the glove box and remove the panel by removing the three clips securing it at the front.
2. You may want to place something on the floorboard to catch any debris that may fall out of the filter during removal.
3. Once the panel is removed, remove the cover from the bottom of the cabin filter housing. It is held in place by a locking clip that will slide towards the rear of the vehicle.
4. To remove the old filter, pull straight down and out of the housing.
5. Slide the new filter into place.
6. Replace the housing cover and slide the locking clip toward the front of the vehicle.



**Application:**

Suzuki Forenza and Reno

Tools:

Unknown or not required.

Location of cabin filter:

On passenger side of the vehicle below glove compartment behind cabin filter access door under dash.

To remove existing filter:

1. Locate and remove the four screws securing the cabin filter access door.
2. Using the tab on the filter, pull out the dirty filter bending (breaking at the perforations) the filter to the right as necessary to remove from the housing.
3. Complete installation by reversing steps 1 and 2.





Application:

BMW X5

Tools:

Unknown or not required.

Location of cabin filter:

In front of the windshield under the hood behind the filter access panel in the center of the vehicle.

Removal of existing filter:

1. Open the hood.
2. Locate the cabin filter access panel.
3. Remove the filter access door by turning the (2) two screws that secure the panel.
4. Remove the filter access panel by lifting upward.
5. Remove the existing dirty filter.
6. Install new filter into the filter housing.
7. Reattach the filter access panel and secure with spring screws.
8. Close hood.





Application:

Ford Contour | Mercury Mystique | Mercury Cougar

Tools:

Standard and Phillips Screwdriver; Torx T30

Location of cabin filter:

In front of the windshield under the vent grille on the passenger side of the vehicle.

To remove existing filter:

1. Turn off ignition switch with the wipers in the vertical position. **(Figure 1)**.
2. With the hood closed use a flat blade screwdriver to gently pry off the two plastic caps (part # H001) covering the screws securing the passenger side vent grille. **(Figure 2)**.
3. Using a Phillips head screw driver remove the two screws (part # H002) securing the passenger side vent grille. **(Figure 3)**.
4. Open hood. Gently pull back the weather-strip from the passenger side vent grille. **(Figure 4)**.
5. Using a Torx driver remove the two Torx head screws (part # H003) that secure the bottom portion of the vent grille. **(Figure 5)**.
6. Gently remove the vent grille. To make this step easier remove the plastic cap and screw securing the center portion of the driver side vent grille. **(Figure 6)**.
7. Unsnap the two clips that secure the filter housing from both sides of the housing. **(Figure 7)**.
8. Slide out the filter and the housing. **(Figure 8 & 9)**.
9. Install new filter and housing. **(Figure 10)**.
10. Reverse steps 1-7 to complete installation.



Figure 1



Figure 2



Figure 3



H001
cowl grille
screw retainer
cap



Figure 4



Figure 5



Figure 6



H002
cowl grille
retainer



H003
cowl grille
screw



Figure 7



Figure 8



Figure 9



Figure 10

**Application:**

Nissan Quest

Tools:

Unknown

Location of cabin filter:

Behind glove compartment, behind cabin filter access door on the passenger side of the vehicle.

To remove existing filter:

1. Open glove compartment and remove the bottom three screws and top four screws securing the glove compartment.
2. Remove the glove compartment and set aside.
3. There is an electrical connector that may need to be unplugged to access the screws securing the cabin filter access door. Unplug if needed and remove the screws securing the cabin filter access door and the door itself.
4. Pull first filter out. To remove the second filter, lift up and slide out.
5. Install the first new filter by sliding in and pushing down.
6. Install the second new filter by sliding it on top of the first filter.
7. Complete installation by reversing steps 1 through 3. Remember to reconnect the electrical connection if you unplugged it.



**Application:**

Chevrolet Tracker | Suzuki Grand Vitara, Vitara, XL7

Tools:

Unknown or not required.

Location of cabin filter:

Behind glove compartment behind cabin filter access door on the passenger side of the vehicle.

Removal of existing filter:

1. Open hood and disconnect the battery ground cable.
2. Allow 2 minutes for the air bag back up system to discharge.
3. Locate and remove the air bag fuse from the fuse panel located on the driver side of the vehicle.
4. Locate and disconnect the air bag electrical connector on the driver side by lifting up on the locking lever.
5. Open the glove compartment and push in on both sides of the glove compartment releasing the glove compartment stops. Swing the glove compartment downward.
6. Locate the passenger side air bag connector through the opening left by the glove compartment and disconnect it by lifting up on the locking lever.
7. Locate and remove the cabin filter access door.
8. Remove the two dirty cabin filters and replace.
9. Complete installation by reversing steps 1-7.

Make sure you reconnect the air bag connector on both the passenger and driver side of the vehicle. Make sure that you replace the air bag fuse located on the driver side of the vehicle.



**Application:**

Volvo 850, C70, S70, S90, V70, V90

Tools:

Unknown or not required.

Volvo 850: (in some cases, the cabin filter may not be fitted as standard in 850 models. The vehicle manufacturer's installation kit is required for first-time installation of the cabin filter in the vehicle.)

Location of cabin filter:

Inside the filter compartment behind the strut mounting on the passenger side of the vehicle.

To remove existing filter:

1. Remove the drain hose and the three screws.
2. Unfold the upper section of the filter cover and insert a support to hold up filter cover.
3. Remove the dirty filter and replace with new filter.
4. Reverse the procedure to install new filter.



**Application:**

BMW 320i, 323i, 323iC, 323Ci, 323iS, 325i, 325Ci, 325Xi, 328i, 328Ci, 328iC, 328iS, 330i, 330Ci, 330Xi, M3, X3

Tools:

Unknown or not required.

Location of cabin filter:

In front of the windshield under the hood behind the filter access panel in the center of the vehicle.

Removal of existing filter:

1. Open the hood.
2. Locate the cabin filter access panel.
3. Remove the filter access door by turning the (3) three spring screws that secure the panel left until they pop up and are no longer securing the access panel.
4. Remove the filter access panel by lifting upward.
5. Remove the existing dirty filter.
6. Install new filter into the filter housing.
7. Reattach the filter access panel and secure with spring screws.
8. Close hood.





Application:

Ford Escort, Focus, ZX2

Tools:

Unknown or not required.

Location of cabin filter:

In front of the windshield under the cowl vent screen behind the filter service flap.

To remove existing filter:

1. Position wiper arms in the vertical position.
2. Unclip the cowl vent screw caps and remove the screws securing the passenger side cowl vent.
3. Remove the passenger side cowl vent.
4. Open the filter service flap and remove the filter.
5. Clean the rubber edging between the wiper motor and the filter housing.
6. Clean the cowl vent gasket.
7. Install the new filter maintaining the proper flow direction.
8. Reverse steps 1-4 to complete installation.



**Application:**

Buick Rendezvous, Terraza | Chevrolet Venture, Uplander | Oldsmobile Silhouette | Pontiac Aztek, Montana | Saturn Relay

Tools:

Not required.

Location of cabin filter:

Inside of the glove compartment behind the air filter access door on the passenger side of the vehicle.

Removal of existing filter:

1. Open the glove compartment door (**Figure 1**).
2. Inside the glove compartment: locate the removable panel on the left hand side of the glove compartment. (**Figure 2**).
3. Pull out on the tab on the bottom of the panel to remove the panel as shown in (**Figure 2**).
4. Located behind the panel is the filter access door. (**Figure 3**).
5. Pull out on the latch on the left hand side of the filter access door and open the filter access door to the right as shown in (**Figure 4**).
6. Remove the two filters from the filter compartment as shown in (**Figure 5**).
7. Reverse procedure to install new filters.

**Figure 1****Figure 2****Figure 3****Figure 4****Figure 5**

**Application:**

Honda Accord 1998-2002 | Acura CL, Acura TL

Tools:

Standard and Phillips screwdriver

Location of cabin filter:

Under the dash behind the glove compartment on passenger side of vehicle.

To remove existing filter:

1. Open the glove compartment and remove the two locking tabs from either side of the glove compartment.
2. Remove four screws from the left, center and right of the glove compartment and close the glove compartment. **(Figure 1, 2).**
3. Remove the access panel from the right side of the glove compartment.
4. Remove the two bottom screws under the access panel. **(Figure 3).**
5. Remove the access panel in center of the console under the radio and remove the screw on the right side of this panel. **(Figure 4).**
6. Remove the access panel under the glove compartment.
7. Remove two screws on the underside of the glove compartment and one screw on the metal bar. **(Figure 5).**
8. Remove the glove compartment, carefully disconnecting the light wire on the left side. **(Figure 6, 7).**
9. Remove the remaining two screws on either side of the metal bar and remove bar. **(Figure 8, 9).** (Do not remove the ground screw.)
10. The cabin filter access door is now visible, pull up on the door to release and remove. **(Figure 10).**
11. Pull out the first filter in housing and slide the second into the opening and remove. **(Figure 11, 12).**
12. Remove the dirty filters from the filter housing and replace with clean filters, paying careful attention to the air flow direction arrows. **(Figure 13).**
13. Reverse steps to complete filter change out.

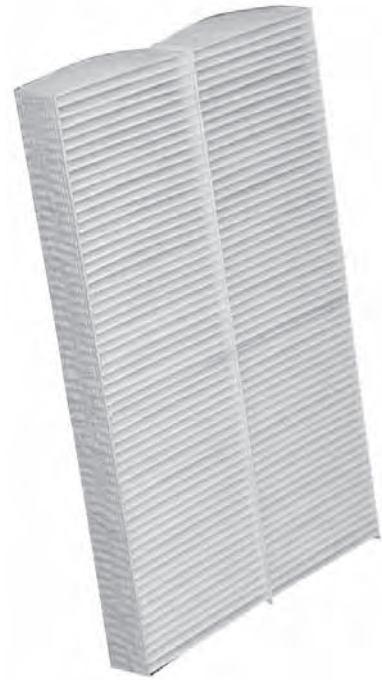

Figure 1



Figure 2



Figure 3



Figure 4



Figure 5



Figure 6



Figure 7



Figure 8



Figure 9



Figure 10



Figure 11



Figure 12



Figure 13

**Application:**

Jeep Grand Cherokee

Tools:

Unknown or not required.

Location of cabin filter:

In front of the windshield under the cowl vent screen on the passenger side of the vehicle.

Removal of existing filter:

1. Open the hood.
2. Grasp the cowl weather-strip on the passenger side and pull it outward to remove it approximately halfway across the firewall.
3. Remove the 3 plastic fasteners securing the cowl vent screen (to ease with removal of the fasteners, gently lift on the end of the cowl vent screen to help get the fasteners started).
4. Gently lift the cowl vent screen enough to locate the plastic air inlet cover or filter housing depending on if this is initial installation. If initial installation, follow the steps below (****for first time installation - a filter housing is required****); if repeat installation, skip these steps and continue with step "5". Locate the plastic tabs that secure the air inlet cover in place. Pull the thin side of the cover out first which is secured by one clip then rock the cover back and forth to remove the "rosebud" clip securing the center of the cover. Remove the cover and disregard or keep so you can install later if desired. The cover will not be needed once new housing and filter is installed.
5. Insert the new filter housing into the inlet opening and secure in place.
6. Reseat the cowl vent screen in place and secure with the cowl vent screen fasteners. (Make sure fasteners are securely in place; if needed, bend the locking tabs out on the fasteners to help them stay in place.)
7. Re-install the cowl weather-strip.



**Application:**

Nissan Cube

Tools:

Phillips-head screwdriver and possibly a razor knife.

Location of cabin filter:

On the passenger side of the vehicle behind the glove compartment behind the cabin filter access panel.

**To remove existing filter:**

1. With glove box closed remove the two screws at the bottom and each end of the glove box. **(Figure 1)**. If this is first time replaced, you may need to use the razor knife and cut zip ties at the bottom of the glove box where you removed the screws. **(Figure 2)**. If you do not have the zip ties just move to the next step.
2. Open the glove box and remove the four screws securing the top of the glove box. **(Figure 3)**. Also remove the two screws inside the glove box toward the bottom. **(Figure 4)**.
3. Remove complete glove box assembly. **(Figure 5)**.
4. In the void left by the glove box assembly, look towards the center console and locate the cabin filter housing cover. Unlatch and remove the cover. **(Figure 6)**.
5. Remove the dirty filter.
6. Install new filter.
7. Re-install the cabin filter cover and make sure it is secure.
8. Reposition the glove box assembly.
9. With glove box open, re-install the four screws at the top and the two screws inside the glove box toward the bottom.
10. Close the glove box and re-install the two screws at the bottom of the glove box.



Figure 1



Figure 2



Figure 3



Figure 4



Figure 5



Figure 6





Application:
Volvo C30, C70, S40, V50

Tools:
Unknown or not required.

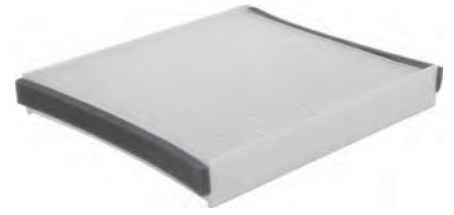

**Application:**

2014 Chevrolet Sierra, Silverado

Tools:

Standard and Phillips screwdriver

Location of cabin filter:

The filter is located behind the glove box.

To remove existing filter:

1. Remove the two screws that secure the bottom of the glove box to the vehicle.
2. Open the glove box.
3. Remove the two screws that secure the top of the glove box to the vehicle.
4. Gently pull out on the glove box to release the four retainer clips.
5. Unclip the top of the filter housing cover and remove the old filter.
6. Install the new filter into the housing with its airflow indicator arrow pointing down.
7. Clip the cover back onto the housing and reinstall the glove box.



**Application:**

2014 Ford Fusion

Tools:

7mm socket wrench, Phillips screwdriver

Location of cabin filter:

Behind the glove box.

To remove existing filter:

1. Open the glove box and remove the piece of trim on the right side. **(Figure 1).**
2. Remove the trim above the glove box by unhooking it starting with the right side. **(Figure 2).**
3. Close the glove box.
4. Using a 7mm wrench remove the two bolts that secure the bottom of the glove box assembly. **(Figure 3).**
5. Using a 7mm wrench remove the two bolts that secure the top of the glove box assembly. **(Figure 4).**
6. Open the glove box.
7. Pull out on the glove box assembly to unclip it from the vehicle. **(Figure 5).**
8. Tilt the glove box assembly and set it on its side to expose the connector on the back.
9. There is a tab on the top of the light connector that will disconnect it from the light. **(Figure 6).**
10. Remove the two Phillips screws from the sides of the filter cover to open it. **(Figure 7).**
11. Pull out on the old filter to remove it from the housing. **(Figure 8).**
12. Install your new filter into the housing with its airflow indicator arrow pointing down.
13. Sit the glove box assembly on its side and reconnect the light connector to the back of the glove box.
14. Clip the glove box assembly back onto the vehicle and make sure it is secure.
15. Reinstall the two bolts at the top of the glove box assembly.
16. Reinstall and close the glove box.
17. Reinstall the two bolts at the bottom of the glove box assembly.
18. Open the glove box.
19. Clip the trim panel above the glove box back onto the vehicle.
20. Clip the trim panel to the right of the glove box back onto the vehicle.
21. Close the glove box.



Figure 1



Figure 2



Figure 3



Figure 4



Figure 5



Figure 6



Figure 7



Figure 8

**Application:**

Mazda 3, 6, CX5

Tools:

Unknown or not required.

Location of cabin filter:

Under the hood on the passenger side of the vehicle.

Removal of existing filter:

1. Remove the glove compartment (**Figure 1**).
2. Remove the cabin air filter.

Installation of new filter:

1. Install in the reverse order of removal.

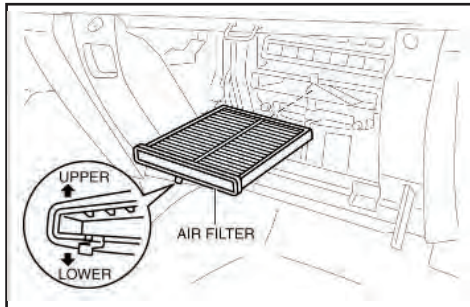

Figure 1

**Application:**

Chrysler 200 | Jeep Cherokee

Tools:

None.

Location of cabin filter:

Under the glove box on the passenger side of the vehicle.

**To remove existing filter:**

1. Remove the passenger side console closeout cover. **(Figure 1)**.
2. Pull the console closeout cover rearwards to disengage the front retaining tab. **(Figure 2)**.
3. Place your left hand on the top of the console closeout cover and your right hand on the right of the console closeout cover. Now pull the closeout cover towards the passenger side of the car. This will cause the rear tabs on the closeout cover to come undone and allow the cover to be removed. **(Figure 3)**.
4. Remove the filter door by pushing down on the tab on the bottom of the door to release the cover, then rotate the door out and lift up. **(Figure 4)**.
5. Remove the cabin filter by pulling it straight out of the housing. Take note of the air filter position indicators. **(Figure 5)**.
6. Install the cabin filter with the air filter position indicators pointing in the same direction as old filter. **(Figure 6)**.
7. Install the filter door. **(Figure 7)**.
8. Install the console closeout cover. **(Figure 8)**.



Figure 1



Figure 2



Figure 3



Figure 4



Figure 5



Figure 6



Figure 7



Figure 8

**Application:**

Ford Fiesta

Tools:

None required.

Location of cabin filter:

In the passenger side footwell behind the fascia panel on the center console.

To remove existing filter:

1. Open the passenger side door and look in the footwell area at the center console and remove the retainer securing the center console side fascia panel against the center console.
2. Remove the side fascia panel. **(Figure 1)**.
3. Now find the rectangular cabin filter cover that was behind the panel you just removed.
4. Using your T-20 Torx wrench, remove the five screws securing the cover and remove the cover. **(Figure 2)**.
5. Remove the dirty cabin filter. **(Figure 3)**.
6. Install the new cabin filter.
7. Reinstall the cabin filter cover and secure it with the five screws.
8. Reinstall the center console side fascia panel and secure it with the screw.



Figure 1

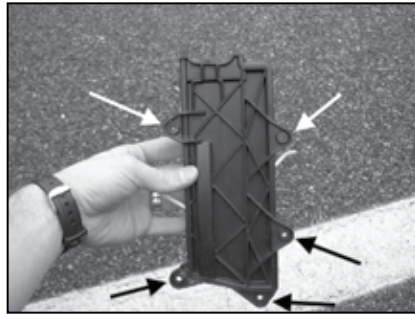

Figure 2

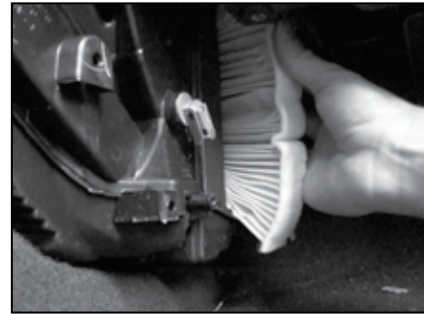

Figure 3

**Application:**

Nissan Rogue

Tools:

None.

Location of cabin filter:

Behind the glove compartment; behind an access door on the passenger side of the vehicle.

**To remove existing filter:**

1. The filter is located on the passenger side of the vehicle.
2. Remove the foot panel closest to the front of the vehicle by pulling it straight out.
3. Pull on the ring located on the front of the filter cover to remove it.
4. Remove the old filter from the housing.
5. Install your new filter into the housing.



Application:

Kia Soul

Tools:

None.

Location of cabin filter:

Behind the glove box.

To remove existing filter:

1. Open the glove box.
2. Remove the upper panel at the back of the glove box by pulling it straight down.
3. Unclip the two clips on the bottom of the filter cover to remove.
4. Remove the old filter by pulling it straight out of the housing.
5. Install your new filter into the housing with its airflow indicator arrow pointing down.
6. Hook the tabs at the top of the filter cover back onto the housing and re-secure the two bottom clips.



**Application:**

Hyundai Sonata

Tools:

None required.

Location of cabin filter:

Glove compartment.

To remove existing filter:

1. Open glove compartment.
2. Remove the two stoppers inside the glove compartment by turning them counterclockwise.
3. Disconnect the support rod on the right side of the glove box and lower the glove box.
4. Unclip the cabin filter access door to remove it.
5. Remove the old cabin filter.
6. Install the new cabin filter.
7. Replace the access door and glove compartment.





Application:

Chevrolet Impala | Cadillac XTS and ATS

Tools:

Phillips-head screwdriver

Location of cabin filter:

Behind the glove box.

To remove existing filter:

1. Open the glove box.
2. Disconnect the dampener arm from the right side of the glove box.
3. Push-in on the glove box to disengage the stops and lower it towards the floor.
4. Remove the panel from behind the glove box by removing the seven Phillips-Head screws.
5. Unclip both sides of the filter cover to remove it.
6. Pull straight out on the old filter to remove it.
7. Install your new filter with the airflow indicator arrow pointing down.
8. Clip the filter cover back onto the housing and make sure it is clipped into place.
9. Reinstall the panel behind the glove box by reinstalling the seven Phillips-Head screws.
10. Pull out on the dampener arm and reattach it to the glove box.
11. Close the glove box. The stops will re-engage.





Application:
2016-18 Ford F150

Tools:
Unknown or not required.

Location of cabin filter:
Behind the glove box.



Open glove box



Disconnect Damper

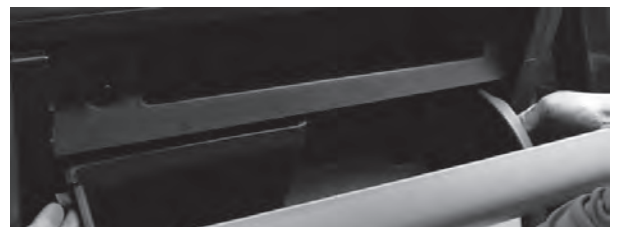

Push in tabs on both sides to cover

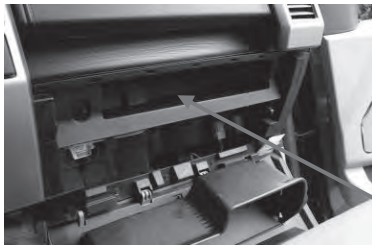

Cover to cabin filter housing located in back of box



Remove cover to expose screws



Remove screws



Drop unit out and disconnect wiring at back of unit



Cover to air filter housing is now exposed and can be removed.



Remove cabin air filter.

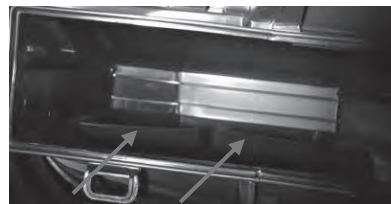

Fins in the bottom of housing.



Replace filter not to catch it on the fins in the housing. Reverse process to re-assembly glove box.

**Application:**

Ford Mustang

Tools:

Unknown or not required.

Location of cabin filter:

Passenger side of the vehicle under the glove box.

To remove existing filter:

1. Remove the retainers and the RH lower instrument panel insulator. See **Figure 1**.
2. Remove the retainer and the cabin air filter cover. See **Figure 2**.
3. Remove the cabin air filter. See **Figure 3**.

Installation:

1. Reverse the removal procedure.



Figure 1

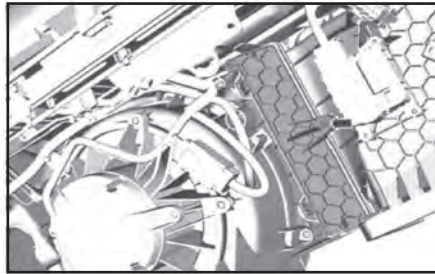

Figure 2

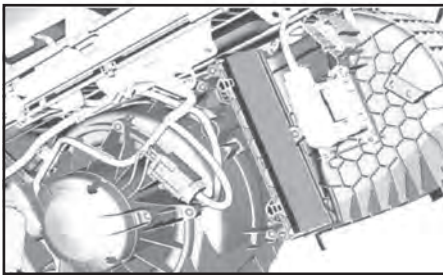

Figure 3

**Application:**

Fiat 500, 500L, 500X | Jeep Compass, Renegade

Tools:

Unknown or not required.

Location of cabin filter:

Passenger side behind the glovebox.



WARNING: To avoid serious or fatal injury on vehicles equipped with airbags, disable the Supplemental Restraint System (SRS) before attempting any steering wheel, steering column, airbags, airbag curtains, knee blocker, seat belt tensioner, impact sensor or instrument panel component diagnosis or service. Disconnect the Intelligent Battery Sensor (IBS)/negative battery cable assembly from the negative battery post, then wait two minutes for the system capacitor to discharge before performing further diagnosis or service. This is the only sure way to disable the SRS. Failure to take the proper precautions could result in accidental airbag deployment.

To remove existing filter:

1. Disconnect and isolate the negative battery cable. If equipped with an Intelligent Battery Sensor (IBS), disconnect the IBS connector first before disconnecting the negative battery cable.
2. Remove the glove box.
3. Release the retainer **(1a)** and remove the cover **(1b)** for the cabin filter. **(Figure 1).**
4. Make note of the air flow direction **(1b)**. Remove the cabin air filter **(1a)** from HVAC housing by pulling the filter element straight out of the housing.

Installation:

1. Make note of the air flow direction **(1b)**. Install the cabin air filter **(1a)** into the HVAC housing.
2. Install the cabin air filter cover **(1b)** into the HVAC housing **(2)** and engage the retaining clip **(1a)**. **(Figure 2).**
3. Install the glove box.
4. Connect the negative battery cable. If equipped with an Intelligent Battery Sensor (IBS), connect the IBS connector.

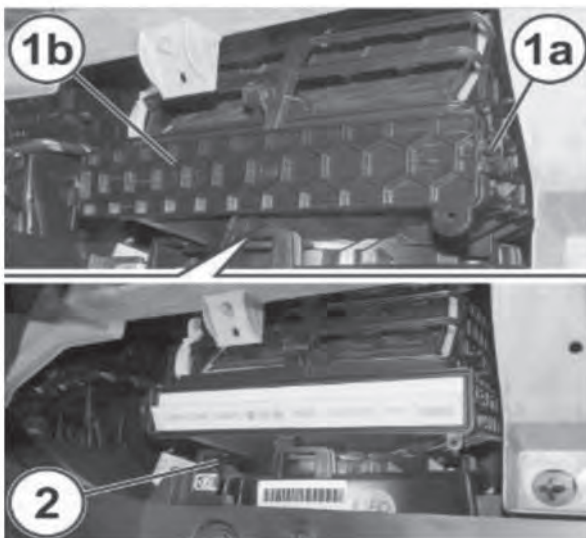

Figure 1



Figure 2

**Application:**

Kia Sorento

Tools:

Unknown or not required.

Location of cabin filter:

The climate control air filter should be replaced according to the maintenance schedule. If the vehicle is operated in severely air-polluted cities or on dusty rough roads for a long period, it should be inspected more frequently and replaced earlier. When you replace the climate control air filter, replace it performing the following procedure, and be careful to avoid damaging other components.

**Removal of existing filter:**

1. Open the glove box and remove the support strap. **(Figure 1).**
2. With the glove box opened, remove the stoppers on both sides. **(Figure 2).**
3. Remove the climate control air filter case by pulling out both sides of the cover. **(Figure 3).**
4. Replace the climate control air filter. **(Figure 4).**
5. Reassemble in the reverse order of disassembly.

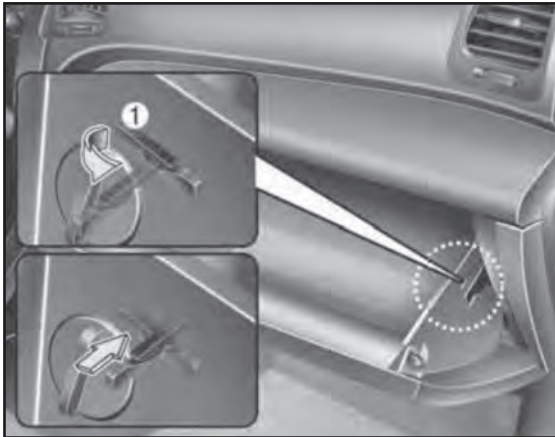

Figure 1

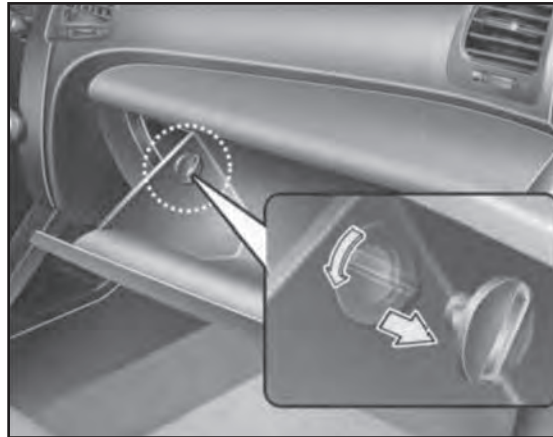

Figure 2

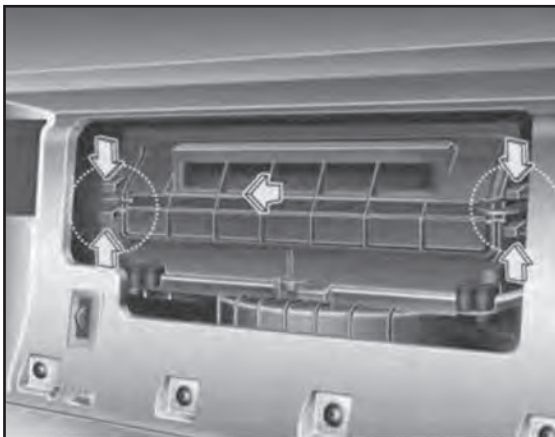

Figure 3

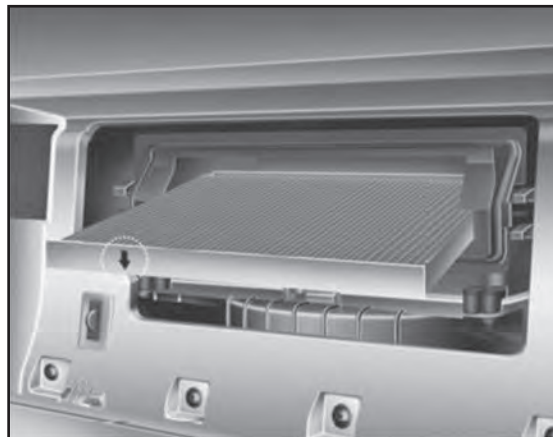

Figure 4



Application:

Audi A3, RS3, TT Quattro | Volkswagen Atlas

Tools:

Hook Tool - T40207- (only necessary if the hook (E) on the service cover (A) is not present. See **Figure 1**). Cover Plate - T10532 - Only for vehicles exposed to high dust and pollution. Standard Vacuum Cleaner - Only for vehicles exposed to high dust and pollution.

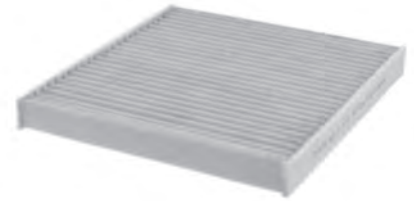

Location of cabin filter:

Passenger side of the vehicle under the glove box.

To remove existing filter:

1. Clean the glove compartment and lay out paper.
2. Unclip the service cover (1) in the glove box by releasing the retainer. (**Figure 2**).
3. Release the retaining tabs (**Arrow A**). (**Figure 2**).
4. Tilt the cover (2) to the rear (**Figure 3**) - when doing this, the guides are disengaged out of the mounts.
5. On a vehicle exposed to higher dust and dirt pollution, push the cover plate-T10532-2 stop under the dust and pollen filter (1) in the shaft for the dust and pollen filter. (**Figure 3**).
6. Remove dust and pollen filter (1) (using the hook on the service cover or the hook tool (**Arrow B**) (**Figure 3**) while doing this). If necessary, hold the pushed cover plate in the dust and pollen shaft.
7. If necessary, clean the dust and the dirt with a vacuum cleaner from the top of the cover plate.

To install new filter:

1. Install in reverse order of removal. Note the following - installation position of the dust and pollen filter (**Figure 4** arrow for the air flow direction on the filter).
2. Switch on the ignition and check the fresh air blower (**V2**) function.

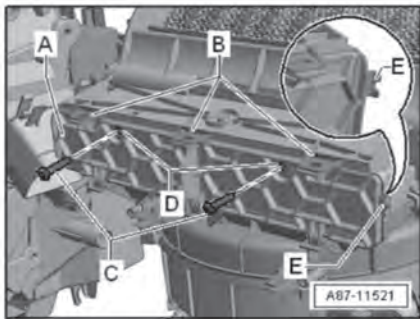

Figure 1

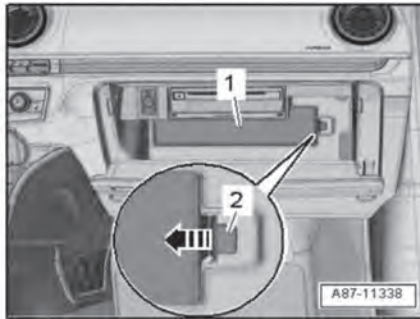

Figure 2

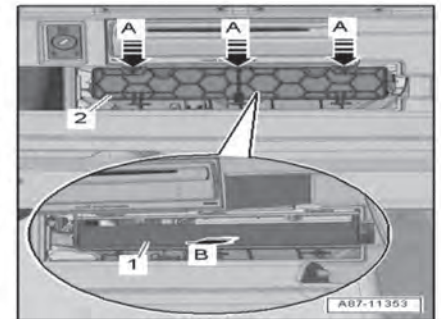

Figure 3

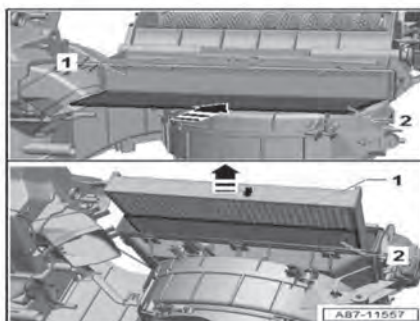

Figure 4



Application:

Hyundai Tucson | Kia Sportage

Tools:

Unknown or not required.



To remove existing filter:

1. Remove the stopper (B) from the glove box (A). See Figure 1.
2. Remove the air damper (A) from the glove box (B). See Figure 2.
3. Remove the filter cover (A) by pressing the knob. See Figure 3.
4. Replace the air filter (A) according to the replacement cycle on the user manual. When replacing it, mind the direction of the air filter. See Figure 4.

Notice:

- To remove the filter easily, press the right-hand side inward and then pull out the filter.
- When driving in an air-polluted area or on rugged terrain, check and replace the air filter as frequently as possible.

5. Install in the reverse order of removal.

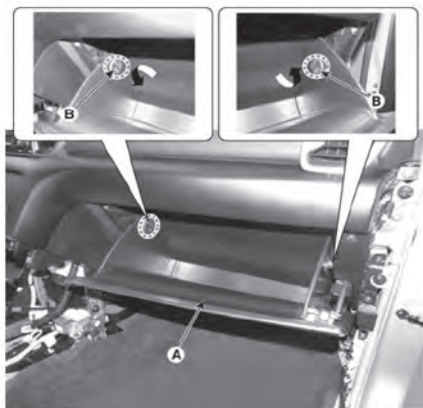

Figure 1

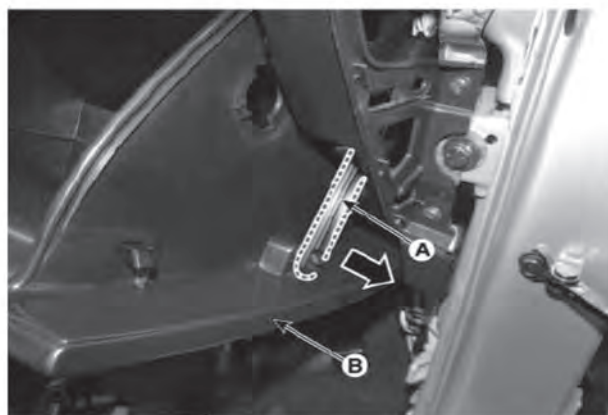

Figure 2

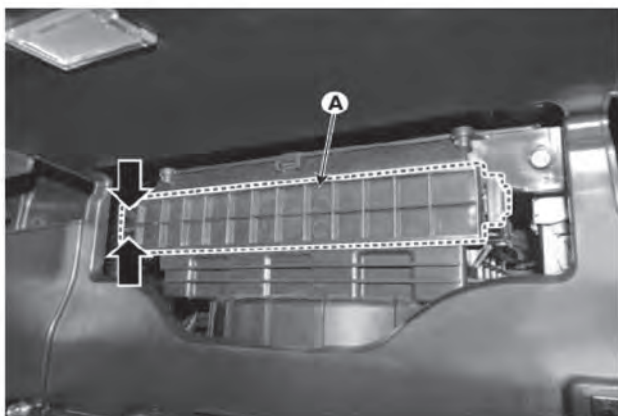

Figure 3

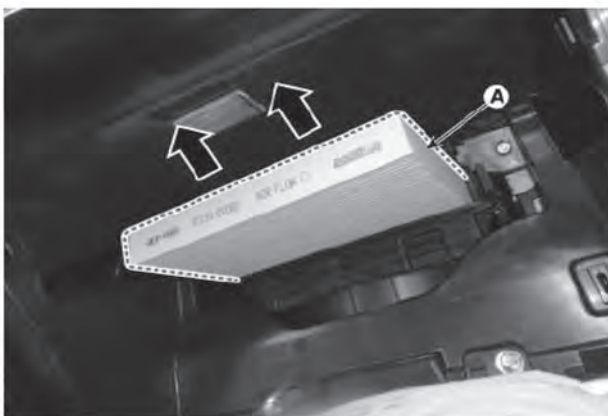

Figure 4



Application:
2017 Hyundai Elantra

Tools:
Unknown or not required.

Location of cabin filter:
Behind glove compartment assembly.

To remove existing filter:

1. Open the glove compartment door assembly.
2. Remove the stopper (**B**) from the glove compartment. (**Figure 1**).
3. Disconnect the damper (**A**) from the door assembly (**Figure 2**).
4. Remove the filter cover by pushing the knob. (**Figure 3**).
5. Replace the filter with a new one taking note of air flow direction. (**Figure 4**).
6. Press the right side of the filter inward then pull filter out.
7. Reverse the process to install the new filter.

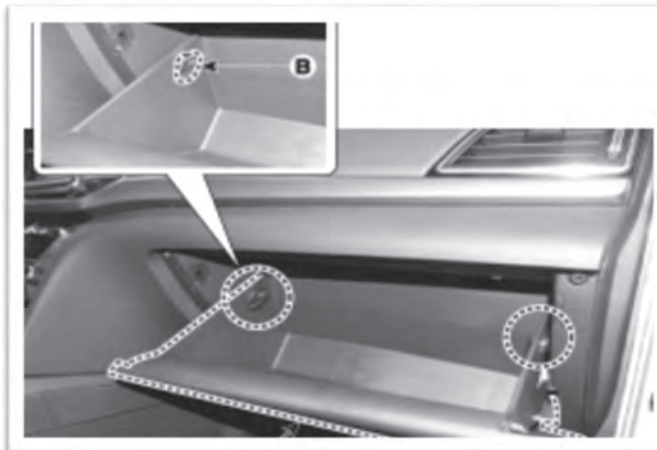

Figure 1

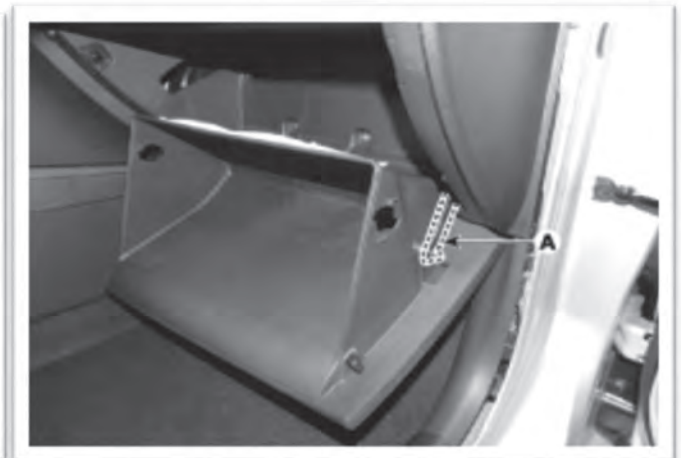

Figure 2

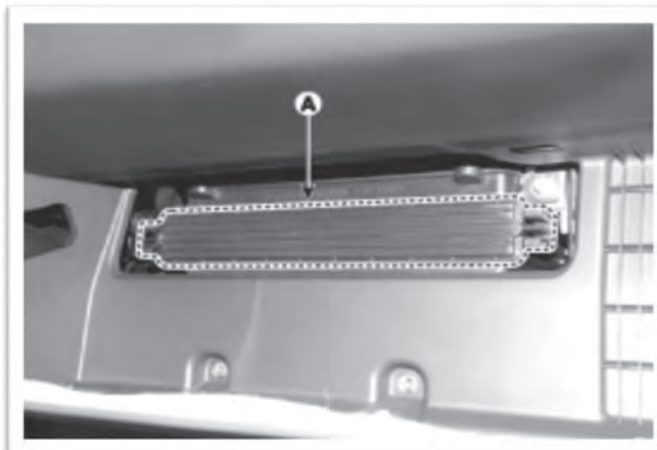

Figure 3



Figure 4

**Application:**

Kia Optima

Tools:

Unknown or not required.

To remove existing filter:

1. Open the glove box and remove contents and set aside. Remove the stoppers on both sides. Carefully lower the glove box. See **Figure 1**.
2. With the glove box open, pull the support strap **(1)**. See **Figure 2**.
3. Pinch the expansion tabs on the right side and remove the cabin air filter door. Remove the used filter and discard. See **Figure 3**.
4. Replace the cabin air filter with the arrow facing up. See **Figure 4**.
5. Reassemble in the reverse order of disassembly.

NOTICE: When replacing the climate control air filter, install it properly. Otherwise, the system may produce noise and the effectiveness of the filter may be reduced.



Figure 1

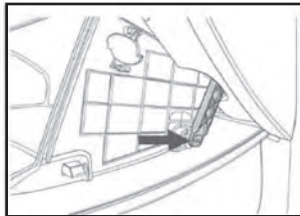

Figure 2

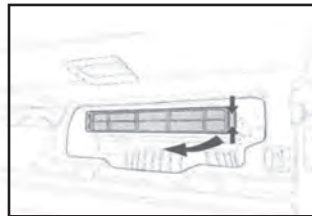

Figure 3

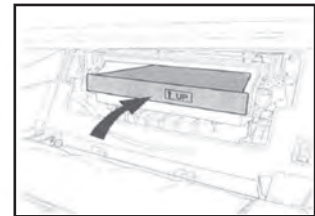

Figure 4

**Application:**

Ram ProMaster 1500, 2500, 3500

Tools:

Unknown or not required.

Location of cabin filter:

Passenger side under the hood.

To remove existing filter:

1. Open the hood to access the air inlet housing.
2. Remove the two fasteners **(1)** that secure the cabin air filter to the air inlet housing. **(Figure 1)**.
3. Remove the cabin air filter **(1)** from the air distribution housing by dropping the filter down, then pulling the filter element straight out of the housing. **(Figure 2)**.

Installation:

1. Install the cabin air filter **(1)** into the filter opening in the air inlet housing. **(Figure 2)**.
2. Position the cabin air filter to the air inlet housing and install the two fasteners **(1)** that secure the filter to the housing. **(Figure 1)**.

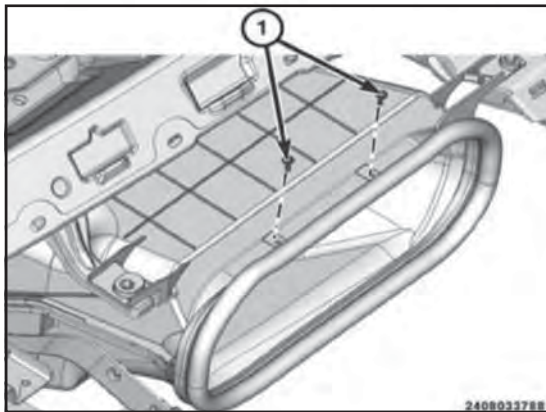

Figure 1

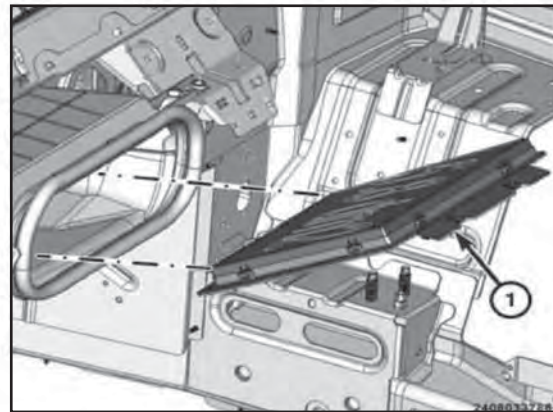

Figure 2

**Application:**

Audi A4, A5, Q5, S4 and S5

Tools:

None required.

Location of cabin filter:

On the passenger side of the vehicle beneath the glove box.

To remove existing filter:

1. Open the passenger door and move the passenger seat as far back as possible.
2. Look under the glove box and remove the three screw clips securing the panel under the glove box. **(Figure 1)**. Remove the panel. **(Figure 2)**.
3. Locate the cabin filter cover and gently slide the cover to remove it. **(Figure 3)**.
4. Remove the dirty cabin filter and replace it with a new cabin filter. **(Figure 4)**.
5. Reinstall the cabin filter cover by sliding it gently back into place.
6. Reinstall the panel and secure it by reinstalling the spring clips.

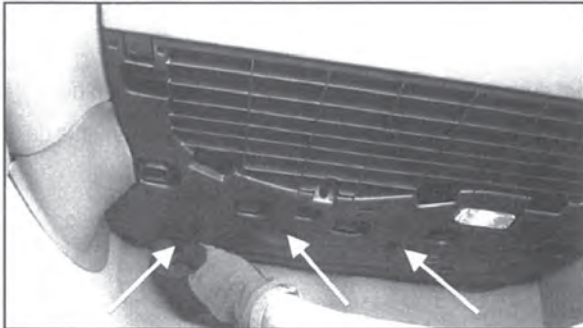

Figure 1

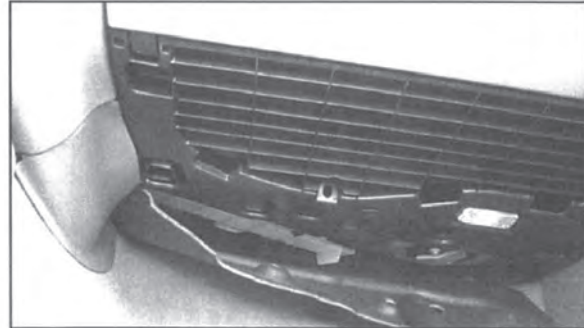

Figure 2

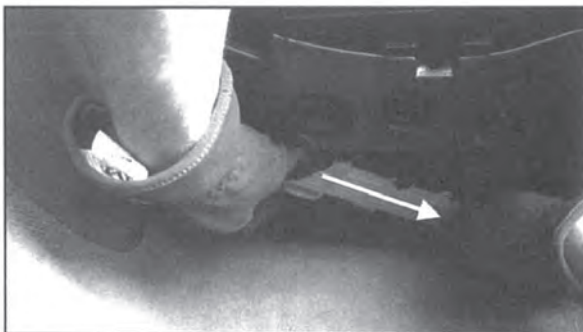

Figure 3

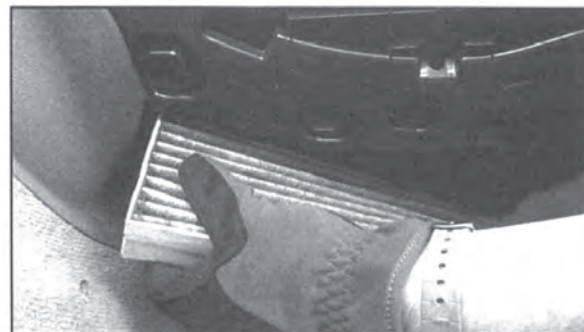

Figure 4

**Application:**

Chrysler Pacifica

Tools:

Unknown or not required.

WARNING:

Always make sure the A/C-heater system is turned off and that the ignition switch is in the OFF position prior to servicing the cabin air filter. Never place fingers or other objects into the filter opening of the HVAC housing. Failure to follow this warning may result in serious injury.

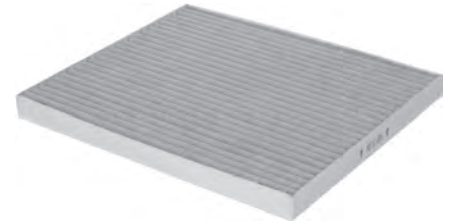
**Removal of existing filter:**

1. Remove the glove box.
 - a. Open the glove box door (2).
 - b. Remove the support strap and retainer from the glove box door. See **Figure 1**.
 - c. Push in on the glove box door stops (1), then rotate the glove box door down and remove. See **Figure 2**.
2. Remove the five hush panel fasteners (2) and remove the hush panel (1). See **Figure 3**.
3. Disengage the two retaining tabs (1) that secure the cabin air filter cover (2) to the passenger side of the HVAC air distribution housing and remove the cover. See **Figure 4**.
4. Remove the cabin air filter (1) from the air distribution housing (2) by pulling the filter element straight out of the housing. See **Figure 5**.

NOTE: The cabin air filter is labeled with “Airflow” and an arrow to indicate air flow direction through the filter. This arrow should always be oriented towards the floor of the vehicle. Make sure to properly install the cabin air filter. Failure to properly install the filter will result in the need to replace the filter sooner than required by design.

5. Reassemble in the reverse order of disassembly.

NOTE: Instrument panel removed for clarity.

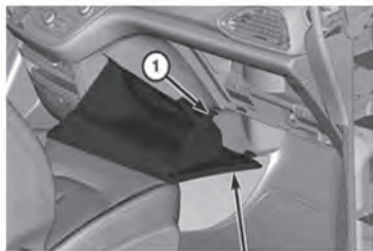

Figure 1



Figure 2



Figure 3

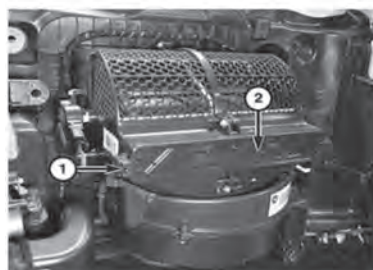

Figure 4

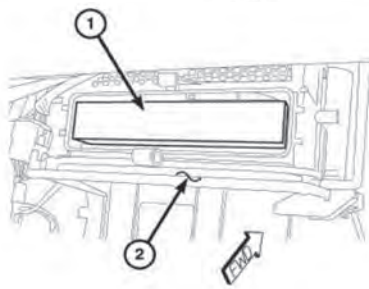

Figure 5

**Application:**

Chrysler 300 | Dodge Charger, Magnum

Tools:

Not required.

Location of cabin filter:

Under the hood, in front of the windshield, under the cabin filter cover, on the passenger side of the vehicle.

To remove existing filter:

1. Open hood.
2. Locate, unsnap and remove cabin filter door on passenger side of the vehicle. **(Figure 1, 2).**
3. Locate in the opening the cabin filter housing cover and flip the cover open. **(Figure 3).**
4. Remove the dirty filter and replace with clean filter. **(Figure 4).**
5. Reverse steps 1 through 3 to complete installation.



Figure 1



Figure 2

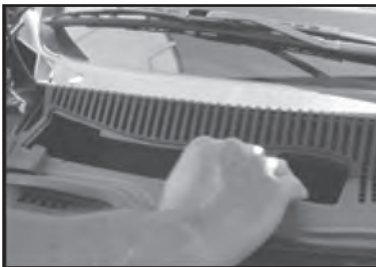

Figure 4



Figure 5



Application:

Lexus RX350, RX450h | Toyota Prius

Tools:

Unknown or not required.

Location of cabin filter:

Behind the glove compartment.

Removal of existing filter:

1. Remove glove compartment door assembly.
2. Remove cabin air filter cover plate.
 - a. Disengage the claw and 2 guides as indicated by the arrows, in the order shown in **Figure 1** to remove the cabin air filter cover plate.
3. Remove Cabin air filter
 - a. Remove the cabin air filter sub assembly as shown in **Figure 2**.
 - b. Disengage the 4 guides to remove the cabin air filter from the cooling unit parts. **Figure 3**.



Installation of new filter:

1. Install cabin air filter
 - a. Engage the 2 guides on the cutout side of the cooling unit parts and then engage the 2 guides as shown in **Figure 4** to install the cabin air filter.

***NOTICE:** Make sure that the “UP” marks are facing the correct direction before installing the cabin air filter. Make sure there is no clearance between the cabin air filter and cooling unit parts and that the clean air filter is not deformed.
 - b. Install the air filter sub-assembly as shown in **Figure 5**.

***NOTICE:** Make sure that the “UP” mark is facing the correct direction before installing the cabin air filter sub-assembly.
2. Install air filter cover plate.
3. Install glove compartment door assembly.



Figure 1

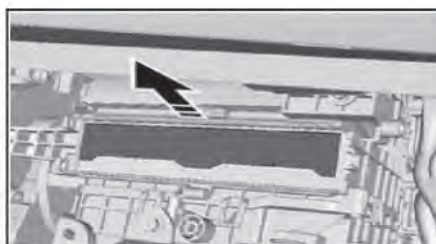

Figure 2

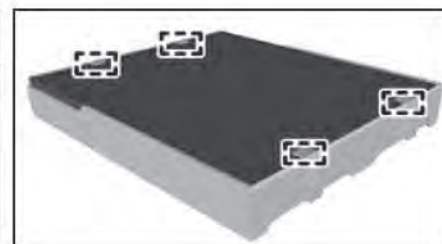

Figure 3

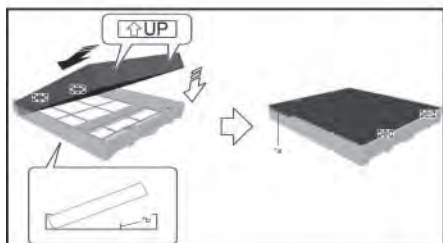

Figure 4

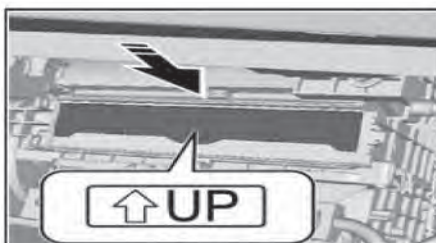

Figure 5



Application:
Nissan Versa

Tools:
Unknown or not required.

Location of cabin air filter:
Behind the console and is accessible from the passenger side.

To remove the existing filter:

1. Locate the cover to the housing behind the console. **(Figure 1)**.
2. Lift the clip at the bottom and pull. **(Figure 2)**.
3. Pull filter out. It may or may not need to be compressed as it comes out of the housing. **(Figure 3)**.
4. Replace cover. **(Figure 4)**.



Figure 1



Figure 2



Figure 3



Figure 4



Application:

Subaru Crosstrek

Tools:

Unknown or not required.

Removal of existing filter:

1. Disconnect the ground cable from battery.
2. Remove the pocket assembly.
 - (1) Remove the damper COMPL - pocket.
 - (2) Release the stoppers and remove the pocket assembly by pulling it toward you.
3. Remove the back panel - pocket.
 - (1) Release the clips, and remove the under cover assembly - passenger.
 - (2) Remove the clips, and remove the cover - instrument panel side RH.
 - (3) Release the clips, and remove the ornament - panel assembly passenger.
 - (4) Remove the glove box light LED, and remove the back panel - pocket.
 - (5) Release the claws and remove the screws, then disconnect the connector.
4. Remove the filter.
 - (1) Release the lock and guide, and remove the filter cover.
 - (2) Remove the filter as shown in the figure.
5. Install new filter and filter cover.
6. Install the pocket assembly in reverse order.

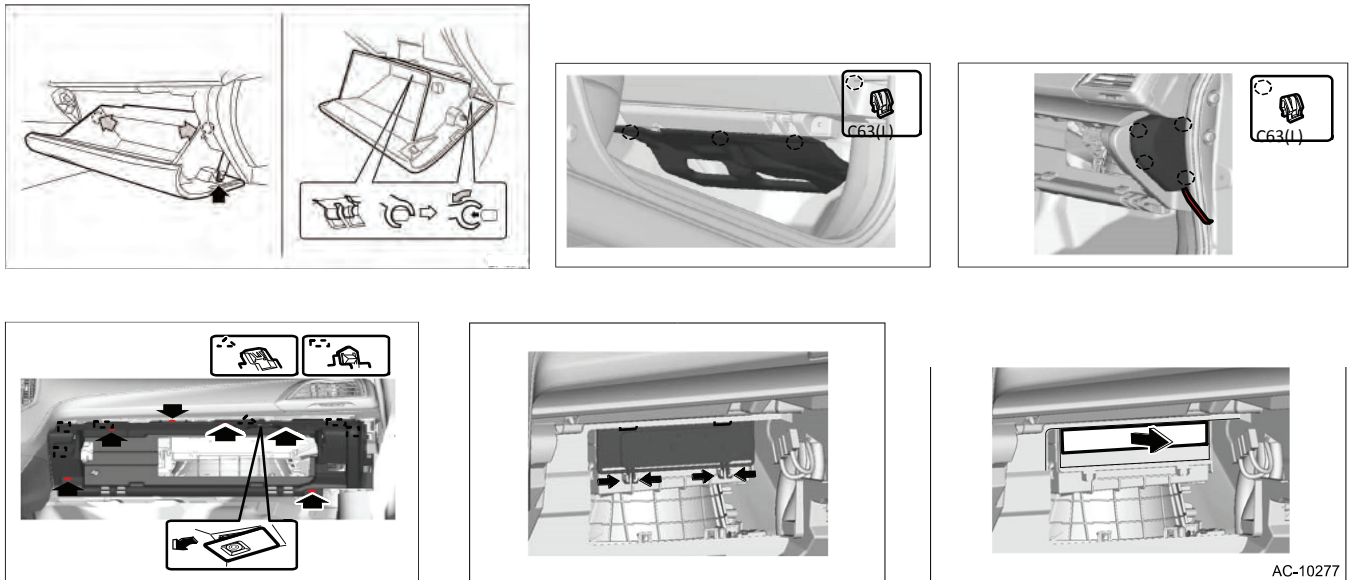
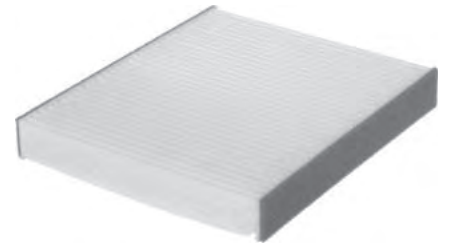

**Application:**

Toyota C-HR

Tools:

Unknown or not required.

Location of cabin air filter:

Behind glove compartment assembly.

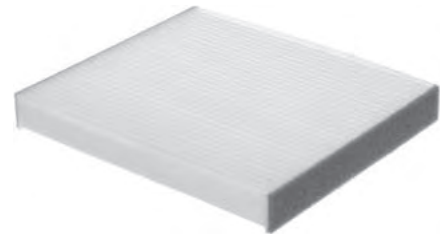
**To remove the existing filter:**

1. Open the glove compartment door assembly.
2. Disengage claw to disconnect door stopper assembly (**Figure 1**).
3. Disengage the stoppers by pushing in and lower the door assembly until it is level. (**Figure 2**).
4. Disengage the hinges to remove the glove compartment door assembly. (**Figure 3**).
5. Disengage the claw and guides on the cabin air filter door. (**Figure 4**).
6. Remove the used filter. (**Figure 5**).
7. Reverse the process to install the new filter.



Figure 1

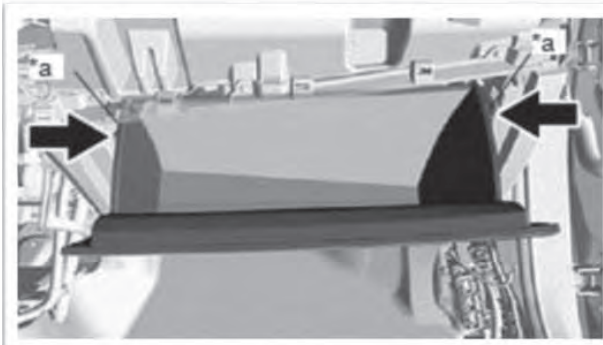

Figure 2

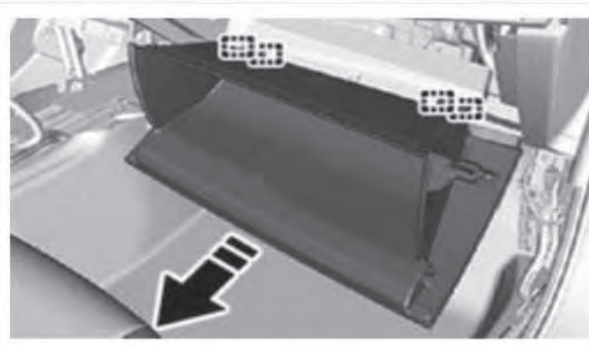

Figure 3

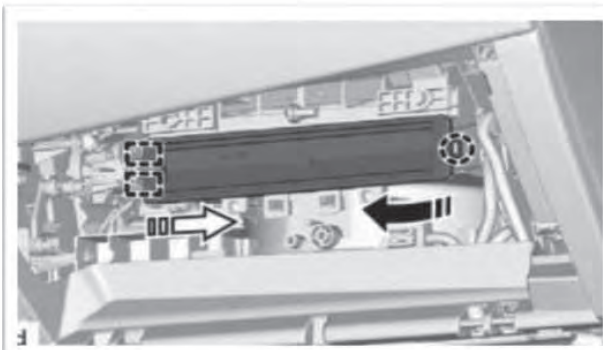

Figure 4

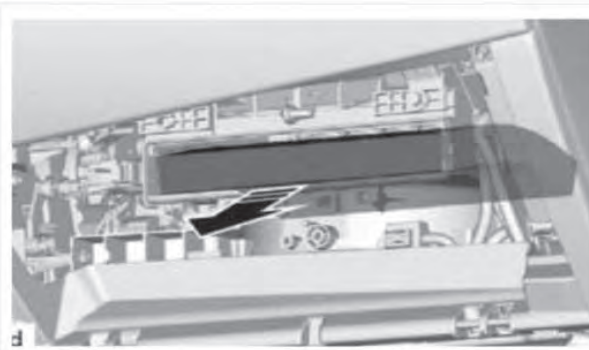

Figure 5

Over-Pressurized Lube Oil Filters

Over-pressurized oil filters: the causes, the solutions.

The oil pressure drops, The red “CHECK ENGINE” light flicks on or the oil gauge drops to zero. You stop your car and check under the hood: your oil filter looks like it has burst. Understandably, you think the filter has failed. You send it back to the manufacturer. He denies any responsibility. You’re upset, of course. If the filter didn’t fail, what did happen?

Lube oil system problems are usually invisible. After they occur, a burst or deformed oil filter is often the only “evidence” you have. Yet it’s misleading. Just as a blown fuse is not the cause of an electrical failure, a burst oil filter isn’t the cause of excessive system pressure. Rather, it is the result of a faulty regulating valve located in the engine.

Fig. 1

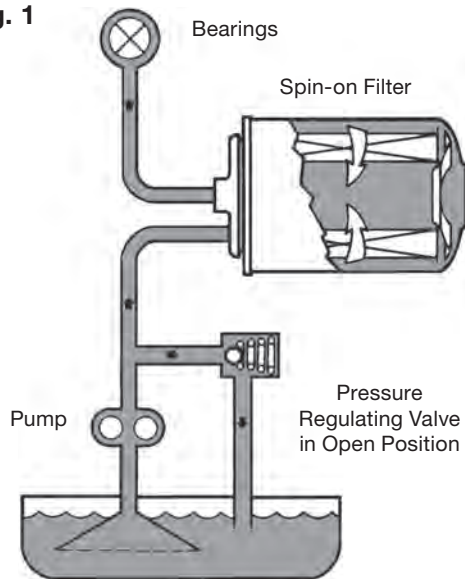
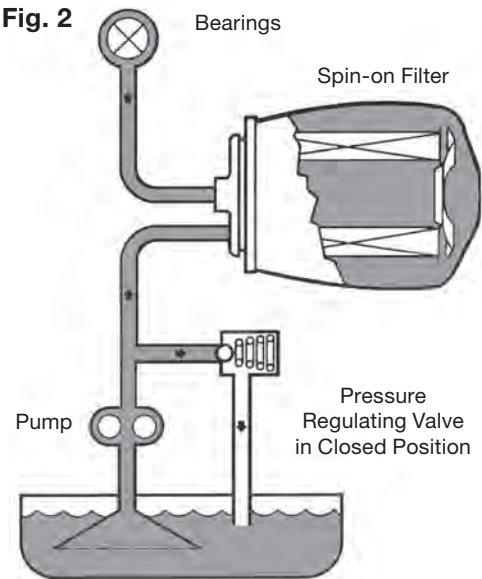

Fig. 2



How your lube system works.

Figure 1 is a simplified diagram of the lube oil system showing the oil pump, regulating valve, and bearings. To properly separate the engine parts and prevent excessive wear, the oil must be under pressure. The pump supplies oil at volumes and pressures greater than what the system requires to lubricate the bearings and other moving parts. The regulating valve opens to allow excessive volume and pressure to be diverted back to the oil pan without causing damage to the filter or engine.

On most automobiles, the regulating valve maintains an oil system pressure of 40 to 60 psi.

What causes over-pressurization?

Excessive engine pressure is the result of a faulty oil pressure regulating valve. There are two ways that the valve fails to operate correctly: either it sticks in the closed position, or it is slow to move to the open position after the engine has started.

Unfortunately, a stuck valve can free itself after filter failure, leaving no evidence of any malfunction.

Figure 2 shows the system operating with the regulating valve stuck in the closed position. Pressure builds up equally on all components. If the regulating valve remains stuck, the pressure will increase dramatically. **Normal pressure plus 100 psi causes filter deformation.** If the regulating valve still remains stuck, the gasket between the filter and the base can blow out, or the filter seam will open. The system will then lose all its oil and pose significant risk to the engine. If you continue to run the engine without oil, considerable damage will occur.

How to minimize the risk of an over-pressurized system.

1. Change the oil and filter often, according to the engine manufacturer’s instructions for frequency, viscosity, and type.
2. Warm the engine on cold mornings before starting to drive to allow oil to flow properly.

Filtros de aceite de lubricación sobrepresurizados

Filtros de aceite sobrepresurizados: las causas, las soluciones.

La presión de aceite disminuye. La luz roja "CHECK ENGINE" (REVISE EL MOTOR) se enciende, o la indicación del instrumento de presión de aceite cae a cero. Usted detiene su auto y revisa el compartimiento del motor: su filtro de aceite parece haber estallado. Comprensiblemente, usted piensa que el filtro falló. Usted lo envía de vuelta al fabricante. Este rechaza toda responsabilidad. Usted, por supuesto, se enoja. Si el filtro no falló ¿qué sucedió?

Los problemas del sistema de aceite de lubricación son normalmente invisibles. Después de que ocurren, a menudo la única "evidencia" que usted tiene es un filtro de aceite roto o deformado. Así y todo, esto es engañoso. Del mismo modo que un fusible quemado no es la causa de una falla eléctrica, un filtro de aceite roto no es la causa de la excesiva presión del sistema. Por el contrario, es el resultado de una válvula reguladora defectuosa ubicada dentro del motor.

Figura 1



Figura 2



Cómo funciona su sistema de lubricación

La figura 1 es un diagrama simplificado del sistema de aceite de lubricación. Se muestran en ella la bomba de aceite, la válvula reguladora y los cojinetes. Para separar adecuadamente las partes del motor y evitar el desgaste excesivo, el aceite debe estar bajo presión. La bomba suministra aceite en volúmenes y presiones mayores que los que el sistema necesita para lubricar los cojinetes y otras piezas móviles. La válvula reguladora se abre para permitir que el volumen y la presión excesivos sean desviados de vuelta hacia el colector de aceite sin causar daños al filtro o al motor.

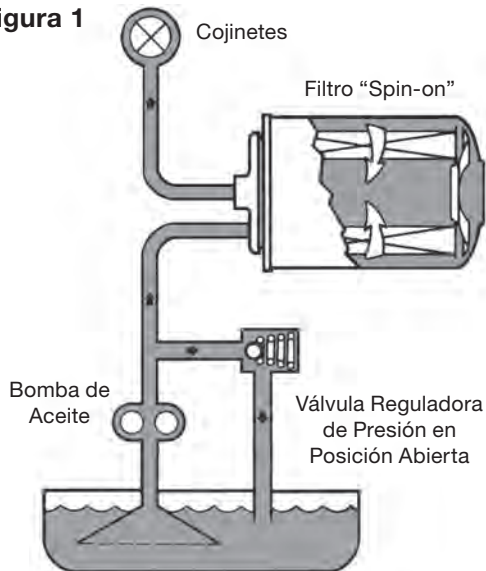
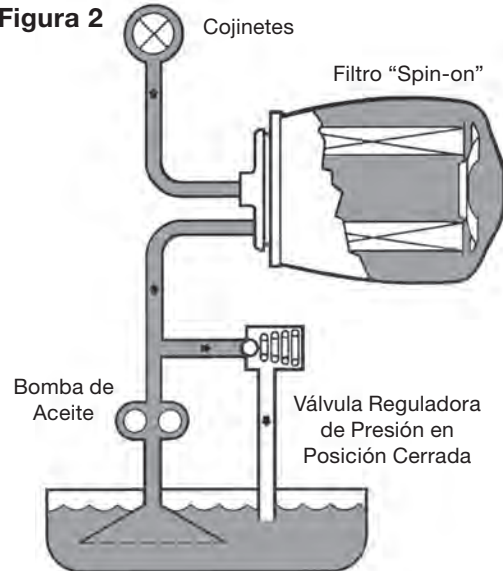
En la mayoría de los automóviles, la válvula reguladora mantiene en el sistema de aceite una presión comprendida entre 40 y 60 psi.

¿Cuál es la causa de la sobrepresurización?

La excesiva presión en el motor es el resultado de una falla en la válvula reguladora de la presión de aceite. Hay dos maneras en que la válvula puede operar incorrectamente: puede trabarse en la posición abierta, o bien, puede moverse muy lentamente hacia la posición abierta una vez que el motor ha arrancado.

Desafortunadamente, una válvula trabada puede liberarse por sí sola después de la rotura del filtro, y así no dejaría evidencia de su mal funcionamiento.

La figura 2 muestra el sistema operando con la válvula reguladora trabada en la posición cerrada. La presión aumenta uniformemente en todos los componentes. Si la válvula reguladora permanece trabada, la presión aumentará dramáticamente. **El incremento de 100 psi por encima de la presión normal origina la deformación del filtro.** Si la válvula reguladora todavía permanece trabada, la junta situada entre el filtro y la base puede estallar, o la costura del filtro puede abrirse. El sistema perderá entonces todo su aceite, presentando así un peligro significativo para el motor. Si usted continúa manejando con el motor sin aceite, se producirá un daño considerable.

Cómo minimizar el riesgo de la sobrepresurización del sistema

1. Cambie el aceite y el filtro a menudo, de acuerdo con las instrucciones del fabricante del motor en todo lo referente a frecuencia del cambio, viscosidad del aceite y tipo de filtro.
2. Caliente el motor en las mañanas frías antes de comenzar a andar, para permitir que el aceite circule adecuadamente.

Surpression des filtres à huile de lubrification

Surpression des filtres à huiles : les causes et les solutions

La pression d'huile baisse, le voyant rouge « CHECK ENGINE » (INSPECTER LE MOTEUR) s'allume et la jauge de pression d'huile tombe à zéro. Vous arrêtez votre véhicule et regardez sous le capot : votre filtre à huile semble avoir éclaté. Vous pensez, c'est bien compréhensible, que le filtre à huile est en faute. Vous le renvoyez à son fabricant. Il décline toute responsabilité. Vous êtes mécontent, bien sûr. Si le filtre n'est pas en cause, qu'est-ce qui s'est passé ?

Les problèmes du circuit de lubrification sont habituellement invisibles. Une fois qu'ils se manifestent, un filtre à huile éclaté ou déformé est la seule « preuve » dont vous disposez. Mais c'est trompeur. Tout comme un fusible fondu n'est pas la cause d'une défaillance électrique, un filtre à huile éclaté n'est pas la cause d'une surpression excessive du système. C'est plutôt la conséquence d'une défaillance du régulateur de pression situé dans le moteur.

Figure 1

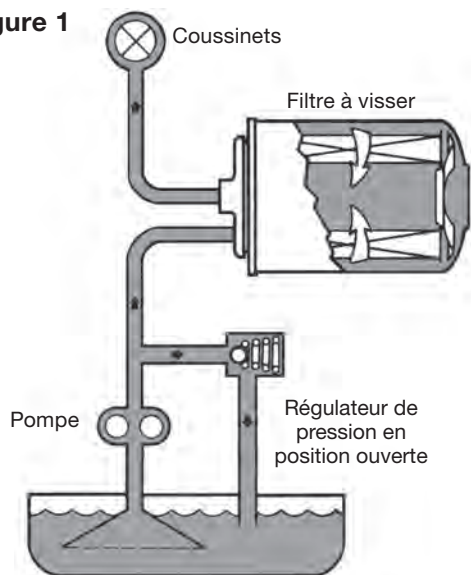
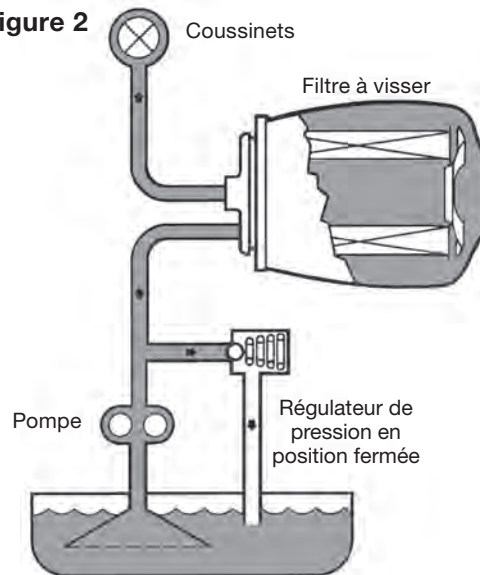

Figure 2



Comment fonctionne votre circuit de lubrification.

La figure 1 est un schéma simplifié du circuit de lubrification montrant la pompe à huile, le régulateur de pression et les coussinets. Pour éviter un contact direct entre les pièces du moteur et prévenir une usure excessive, l'huile doit être sous pression. Le débit et la pression d'huile fournis par la pompe sont supérieurs à ce que requiert la lubrification des paliers et des autres pièces en mouvement. Le régulateur s'ouvre pour envoyer l'excédent de volume et de pression au carter d'huile et ainsi ne pas endommager le filtre ou le moteur. Dans la plupart des automobiles, le régulateur maintient la pression d'huile entre 40 et 60 psi (276 et 414 kPa).

Qu'est ce qui cause la surpression ?

Une surpression excessive dans le moteur est due à une défaillance du régulateur de pression d'huile. Le mauvais fonctionnement du régulateur survient pour deux raisons : soit il se coince en position fermée, soit son ouverture est trop lente lors de la mise en marche du moteur.

Malheureusement, un régulateur coincé peut se décroincer de lui-même après une défaillance du filtre, ce qui efface toute preuve de son mauvais fonctionnement.

La figure 2 montre un système fonctionnant avec un régulateur bloqué en position fermée. La pression augmente uniformément au niveau de tous les organes du moteur. Si le régulateur reste bloqué, la pression va augmenter de manière dramatique. La pression normale plus 100 psi (690 kPa) va déformer le filtre. Si le régulateur reste bloqué, le joint entre le filtre et la base risque d'éclater, ou bien le joint de soudure du filtre va s'ouvrir. Le circuit va alors perdre toute son huile, ce qui présente des risques certains pour le moteur. Si le moteur continue à tourner sans huile, il subira des dégâts considérables.

Comment réduire les risques de surpression du système

1. Changer fréquemment l'huile et le filtre, conformément aux recommandations du constructeur du moteur en ce qui concerne les intervalles de vidange, ainsi que la viscosité et le type de l'huile utilisée.
2. Faire chauffer le moteur les matins froids avant de prendre la route pour permettre un écoulement normal de l'huile.

Oil Pressure Warning Light Problems

Most present day cars use a warning light mounted on the instrument panel to provide the driver with a visual signal of low oil pressure. Low oil pressure is **serious**, since oil under pressure is necessary to properly separate the highly loaded parts of the engine and prevent excessive wear.

The warning light is wired in series with an oil pressure switch as shown in Figure 1. The pressure switch contains electrical contacts which are in the closed position when the oil pressure is below 5 PSI.

When the engine is not running and the ignition switch is turned on, the warning light comes on. When the engine is started, oil pressure will compress the diaphragm in the pressure switch, opening the contacts and causing the light to go out.

If the warning light remains on for more than one or two seconds after the engine has been started, **shut it down immediately**. Then the oil level should be checked and brought up to normal. If the warning light remains on when the oil level is normal, there are a number of possible problems:

1. The pressure switch could be faulty.
2. The wiring between the pressure switch and the warning light could be grounded.
3. The pump could have lost its prime due to either a faulty pump or a clogged suction strainer.
4. A faulty pressure regulating valve could be dumping all the oil back into the crankcase.

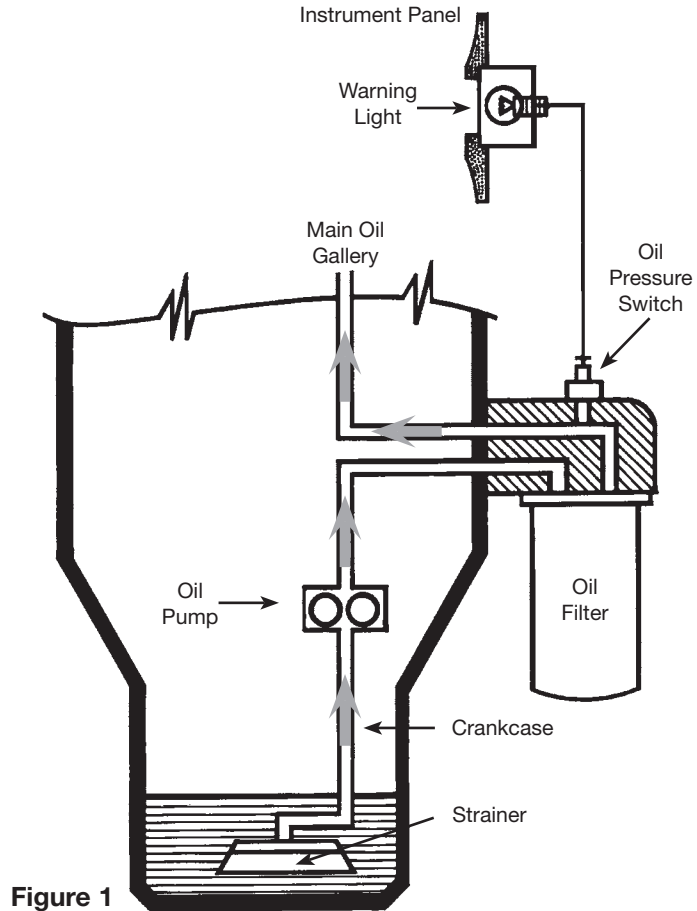

Figure 1

On some engines the filter is mounted in a position which allows the oil in the filter to drain back to the crankcase when the engine is stopped. This would be the case for the filter mounting shown in Figure 2 where the filter is horizontal and is above the level of the oil in the crankcase. Since a filter holds up to a quart of oil, it takes about 5 seconds for the pump to fill the filter after the engine has been started during which time the warning light will remain on.

To prevent the engine from operating without oil pressure for this period of time after startup, the filters designed for these special mounting positions contain an anti-drain back valve. This valve is usually in the form of a rubber gasket which allows the free flow of oil through the filter in the normal direction, but when the engine is shut down it prevents the oil in the filter from draining back to the crankcase. If the warning light remains on for longer periods after the filter has been on the car for some time, replacing the filter is recommended.

Under some conditions the warning light may flicker when the engine is running. This usually happens when the car is going around a corner or is on a relatively steep hill. If flickering occurs under these conditions, it is because the oil level is low and the pump strainer is no longer fully submerged in the oil. The oil level should be immediately brought up to normal.

In summary, the oil pressure warning light provides vital information to the driver. If the light remains on or even flickers when the engine is running, it should be shut off immediately and the cause investigated.

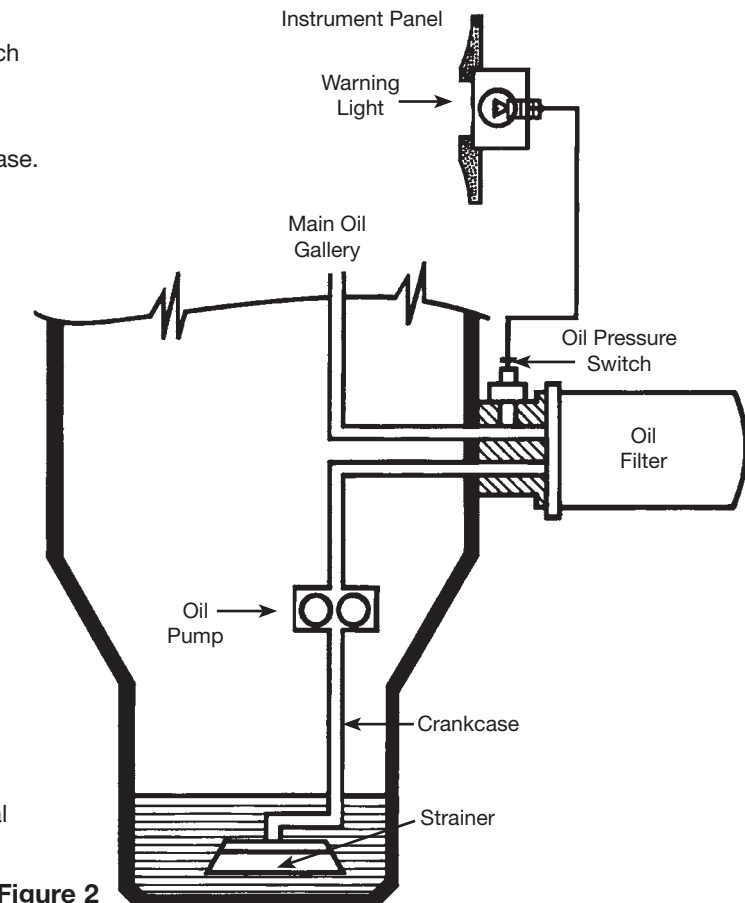

Figure 2

Problemas de la luz de alarma de presión de aceite

La mayoría de los autos actuales usan una luz de alarma, montada en el panel de instrumentos, que le brinda al conductor una señal visual de baja presión de aceite. Esta condición de baja presión de aceite es **seria**, porque la presión de aceite es necesaria para separar debidamente las partes del motor sometidas a altas cargas, y evitar así el desgaste excesivo.

La luz de alarma está conectada en serie con un interruptor de presión de aceite, como muestra la Figura 1. El interruptor de presión contiene contactos eléctricos que están en posición cerrada cuando la presión de aceite es menor de 5 psi.

Cuando el motor no está funcionando y la llave de encendido hace contacto, la luz de alarma se enciende. Cuando el motor arranca, la presión de aceite comprimirá el diafragma del interruptor de presión, abriendo así sus contactos y haciendo que la luz se apague.

Si la luz de alarma permanece encendida por más de uno o dos segundos después de que el motor ha arrancado, **deténgalo inmediatamente**. Luego, debe verificarse el nivel de aceite y –si fuera necesario– hacerlo volver a su nivel normal. Si la luz de alarma permanece encendida cuando el nivel de aceite es normal, varios son los problemas posibles:

1. El interruptor de presión puede haber fallado.
2. El cable de conexión entre el interruptor de presión y la luz de alarma podría estar cortocircuitado a tierra.
3. La bomba podría haber perdido su cebado, debido ya sea a una falla propia o a la obstrucción del filtro de succión.
4. Una válvula de regulación de presión defectuosa podría estar descargando todo el aceite de vuelta al cárter.



Figura 1

En algunos motores, el filtro está montado en una posición que permite que el aceite contenido en el filtro se drene de vuelta al cárter cuando el motor se detiene. Este sería el caso para el montaje de filtro que muestra la Figura 2, donde el filtro es horizontal y está por encima del nivel del aceite en el cárter. Debido a que un filtro almacena hasta un cuarto de galón (aproximadamente 0,95 litros) de aceite, la bomba tarda alrededor de 5 segundos para llenar el filtro después de que el motor ha arrancado. Durante ese intervalo de tiempo, la luz de alarma permanecerá encendida.

Para evitar que el motor opere sin presión de aceite durante este período a partir del arranque, los filtros diseñados para trabajar en estas posiciones de montaje especiales contienen una válvula antidrenaje de retorno. Esta válvula tiene normalmente la forma de una junta de goma que permite el flujo libre de aceite a través del filtro en la dirección normal, pero cuando el motor se detiene impide que el aceite contenido en el filtro se drene de vuelta al cárter. Si la luz de alarma permanece encendida por períodos mayores después de que el filtro ha estado en el auto por un tiempo, se recomienda cambiar el filtro.

Bajo ciertas condiciones, la luz de alarma puede destellar mientras el motor está en marcha. Esto ocurre normalmente cuando el auto está doblando una esquina, o está sobre una camino de montaña de pendiente relativamente alta. Si se observa que en esas condiciones la luz destella, es porque el nivel de aceite es bajo y el filtro de la bomba ha dejado de estar sumergido totalmente en aceite. Se debería llevar el nivel de aceite a la normalidad inmediatamente.

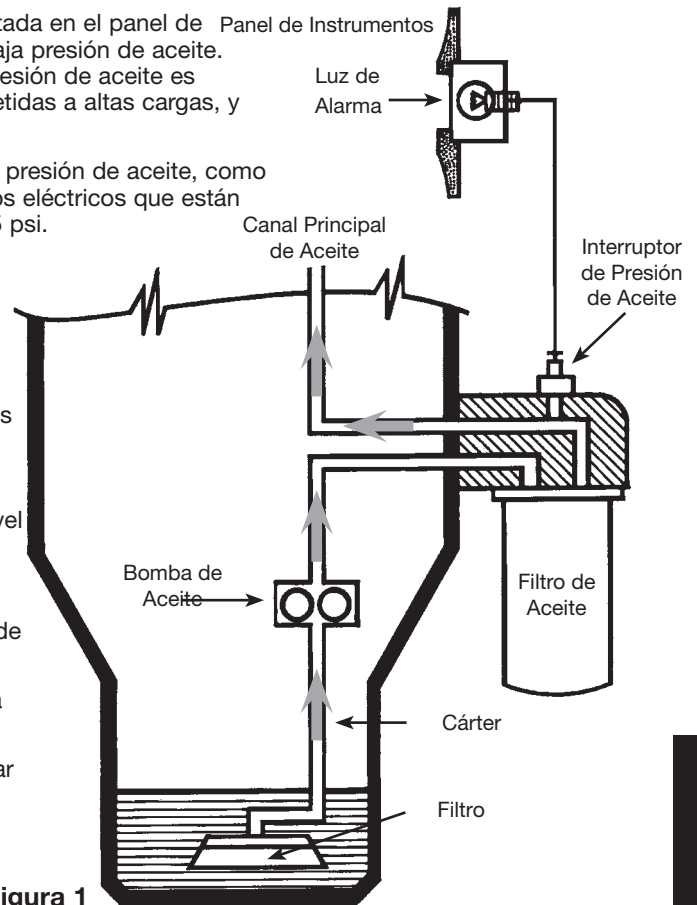
En resumen, la luz de alarma de presión de aceite provee una información que es vital para el conductor. Si la luz permanece encendida o parpadea mientras el motor está en marcha, éste debe ser detenido inmediatamente y la causa debe ser investigada.



Figura 2

Problèmes relatifs au témoin de pression d'huile

La plupart des automobiles possèdent de nos jours, sur leur tableau de bord, un témoin lumineux avertissant le conducteur lorsque la pression d'huile est basse. Une basse pression d'huile est un **grave** problème si l'on considère que l'huile sous pression sert à séparer les pièces très sollicitées du moteur et à prévenir l'usure excessive.

Le témoin est branché en série à un manocapteur de pression d'huile, tel qu'illustré à la figure 1. Le manocapteur de pression comporte des contacts électriques qui se trouvent en position fermée lorsque la pression d'huile est inférieure à 5 psi. Quand le moteur n'est pas en marche et que l'on tourne le commutateur de contact, le témoin s'allume. Une fois le moteur en marche, la pression d'huile comprime le diaphragme du manocapteur de pression, ce qui entraîne l'ouverture des contacts et fait s'éteindre le témoin.

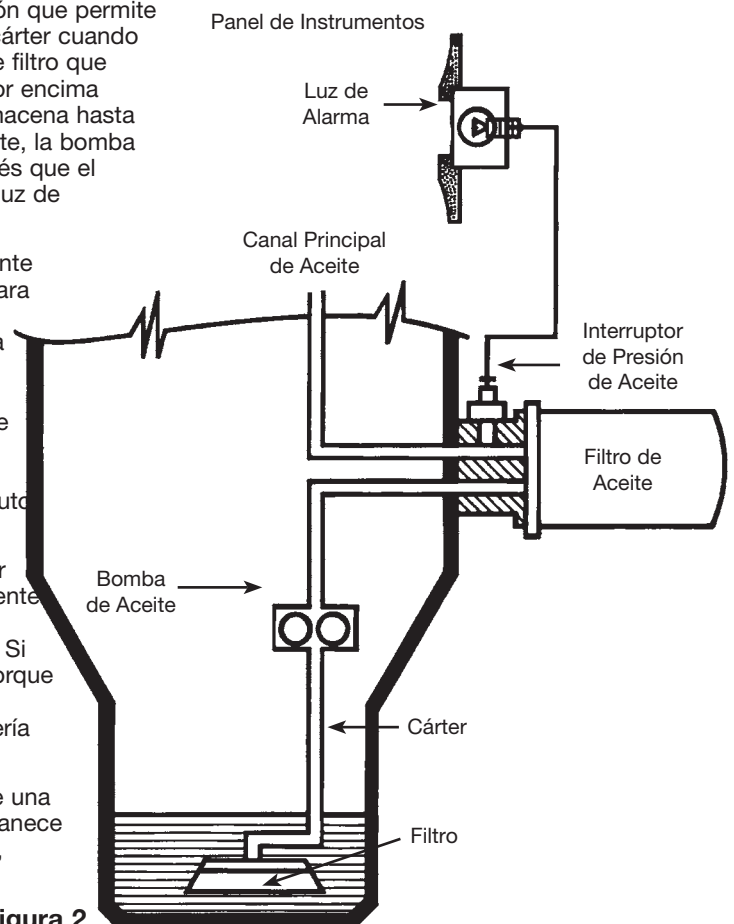
Si le témoin demeure allumé pendant plus d'une ou de deux secondes après la mise en marche du moteur, **éteignez-le immédiatement**. Il faut alors vérifier le niveau d'huile et le ramener à son niveau normal. Si le témoin demeure encore allumé, plusieurs problèmes peuvent en être la cause :

1. Le manocapteur de pression peut être défectueux.
2. Le câblage entre le manocapteur de pression et le témoin est peut-être mis à la terre.
3. La pompe peut être désamorcée, en raison d'une défectuosité ou d'une crépine d'aspiration encrassée.
4. Une soupape de régulation défectueuse peut renvoyer toute l'huile au carter.

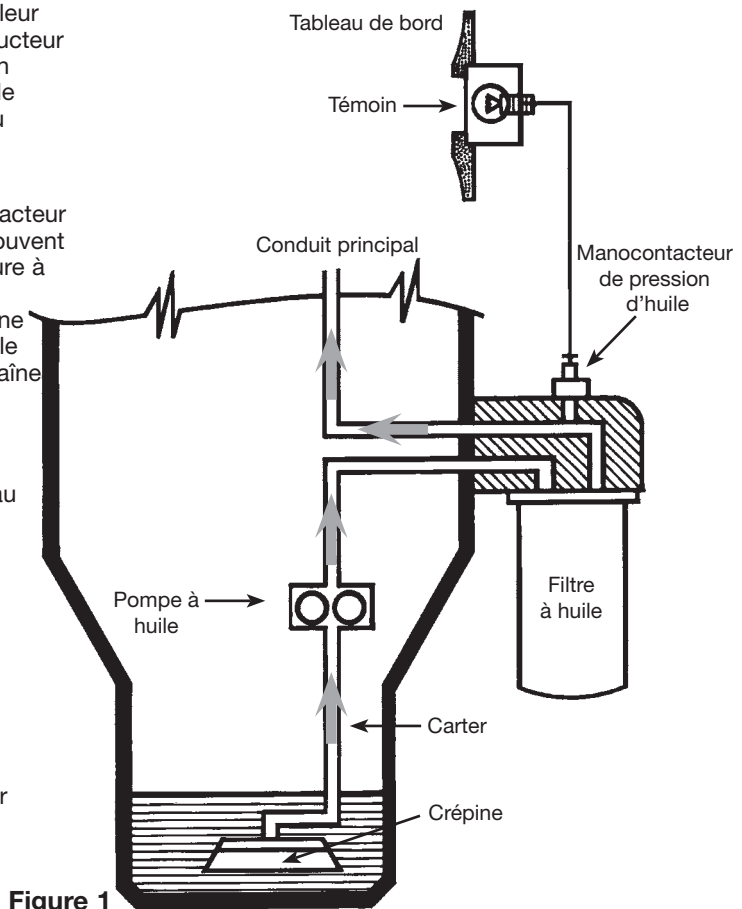

Figure 1

Sur certains moteurs, le filtre est installé d'une façon permettant à l'huile qui s'y trouve de retourner au carter lorsqu'on éteint le moteur. L'installation montrée à la figure 2, où le filtre est placé à l'horizontale et au-dessus du niveau de l'huile du carter, en est un exemple.

Comme un filtre peut contenir jusqu'à un litre d'huile environ, la pompe prend autour de 5 secondes pour remplir le filtre une fois que le moteur a démarré. Pendant ce temps, le témoin reste allumé.

Pour éviter que le moteur ne fonctionne sans pression d'huile durant cette période, les filtres ainsi conçus comportent une soupape empêchant le retour d'huile. Cette soupape consiste souvent en un joint de caoutchouc permettant la circulation d'huile dans le filtre dans la direction normale, mais empêchant l'huile de retourner au carter une fois que le moteur est éteint. Si le filtre est installé depuis un certain temps et que le témoin reste allumé plus longtemps qu'à l'habitude, il est recommandé de remplacer le filtre.

Il peut arriver que le témoin vacille pendant que le moteur est en marche. Cela se passe généralement quand le véhicule tourne un coin ou se trouve sur une pente relativement prononcée. Dans ces cas, cela se produit parce que le niveau d'huile baisse et que la crépine de la pompe n'est plus complètement submergée d'huile. Le niveau d'huile devrait revenir à la normale immédiatement.

Pour résumer, le témoin de pression d'huile fournit de l'information indispensable au conducteur. S'il demeure allumé ou même qu'il vacille quand le moteur est en marche, il faut éteindre le moteur et en trouver la cause.

Figure 2

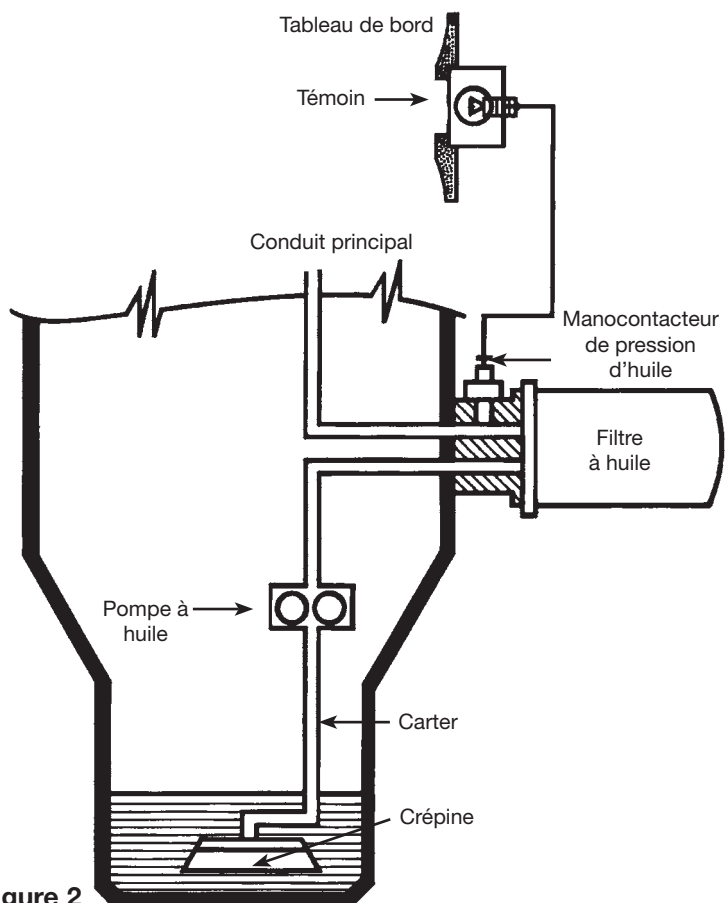

Standard vs. Metric Threads

Vehicle manufacturers such as Chrysler, Mitsubishi, and Renault have applications listed in this catalog that utilize either a METRIC 20mm or a STANDARD 3/4-16 threaded filter mounting adapter (the threaded spud that holds the filter onto the engine).

It is very important that the oil filter adapter size be verified prior to the selection and installation of a replacement oil filter. Use of a METRIC threaded filter on the STANDARD threaded mounting adapter will result in loss of oil and possible engine damage.

To ensure that you select the correct replacement filter you must first determine the correct threaded adapter for your vehicle. Provided that you have a high-quality 3/4 inch open-end wrench with an accurate 3/4 inch opening, follow these simple steps:

1. Drain oil and remove the existing filter.
2. Using a high quality 3/4 inch open-end wrench try to slip the open end of the wrench over the adapter threads.
3. If the 3/4" wrench fits around the threads your vehicle is equipped with the STANDARD 3/4-16 filter adapter.
4. If the 3/4" wrench does not fit over the threads your vehicle is equipped with a METRIC 20mm filter adapter.

The final responsibility of the oil filter selection and installation rests with the installer. If you are still unsure of the correct replacement filter for your vehicle consult your local dealer.

Roscas estándar y métricas

Algunos fabricantes de vehículos tales como Chrysler, Mitsubishi y Renault tienen aplicaciones incluidas en este catálogo que utilizan un adaptador de montaje para filtro (el perno roscado que sujeta el filtro sobre el motor) con rosca METRICA de 20 mm, o bien con rosca STANDARD 3/4-16.

Es muy importante verificar el tamaño del adaptador del filtro de aceite, antes de seleccionar e instalar un filtro de aceite de repuesto. El uso de un filtro con rosca METRICA sobre un adaptador de montaje con rosca STANDARD resultará en pérdida de aceite y posible daño al motor.

Para asegurarse de seleccionar el filtro de reemplazo correcto, usted debe determinar previamente el adaptador roscado que corresponde a su vehículo. Si usted cuenta con una llave abierta de 3/4" de alta calidad, con una abertura exacta de 3/4", siga estos sencillos pasos:

1. Drene el aceite y remueva el filtro existente.
2. Usando una llave abierta de 3/4" de alta calidad, trate de deslizar el extremo abierto de la llave sobre los filetes de la rosca del adaptador.
3. Si la llave de 3/4" se ajusta debidamente sobre la rosca, su vehículo está equipado con un adaptador para filtro con rosca STANDARD 3/4-16.
4. Si la llave de 3/4" no se ajusta debidamente sobre la rosca, su vehículo está equipado con un adaptador para filtro con rosca METRICA de 20 mm.

La responsabilidad final por la selección e instalación del filtro de aceite recae sobre el instalador. Si usted no está todavía seguro sobre el filtro de reemplazo correcto para su vehículo, consulte a su proveedor local.

Standard / Métrique

Les constructeurs automobiles comme Chrysler, Mitsubishi et Renault, ont des applications listées dans ce catalogue qui utilisent un adaptateur de montage de filtre au filetage soit MÉTRIQUE 20 mm, soit STANDARD 3/4-16 (l'embase fileté qui maintient le filtre sur le moteur).

Il est très important que la taille de l'adaptateur du filtre à huile soit vérifiée avant la sélection et l'installation du filtre de rechange. L'utilisation d'un filtre au filetage MÉTRIQUE sur un adaptateur de montage au filetage STANDARD entraînera une perte d'huile et la possibilité de dommages au moteur.

Pour vous assurer que vous avez choisi le bon filtre de remplacement, vous devez d'abord déterminer le bon adaptateur fileté convenant à votre véhicule. En supposant que vous disposiez d'une clé à fourche de bonne qualité taille 3/4" très précisément, suivez ces étapes très simples :

1. Vidangez l'huile et enlevez le filtre existant.
2. En utilisant la clé à fourche de précision à 3/4", essayez de glisser son ouverture sur les filets de l'adaptateur.
3. Si la clé arrive juste à entourer les filets, votre véhicule est équipé d'un adaptateur de filtre STANDARD 3/4-16.
4. Si la clé n'arrive pas à entourer les filets, votre véhicule est équipé d'un adaptateur de filtre MÉTRIQUE 20 mm.

La responsabilité finale de la sélection et de l'installation du bon filtre à huile incombe à l'installateur. Si vous n'êtes toujours pas certain du bon filtre pour un remplacement sur votre véhicule, veuillez consulter votre concessionnaire local.

Loss of Oil Pump Prime

Immediately after an oil change one of the most confusing issues to face the typical do-it-yourselfer or professional mechanic is failure to get oil pressure back into the operating range.

Although not a common occurrence, it is very possible that the oil pump may lose its prime during the oil change.

When the used motor oil is drained from the engine the oil may also drain from the oil pump pickup tube and possibly from the oil pump itself. When new motor oil is installed the pump's pickup tube inlet again becomes submerged trapping air in the tube on the suction side of the oil pump. The trapped air will cause cavitation of the pump and prevent it from producing oil flow and subsequent oil pressure.

Many installers tend to blame this on the oil filter and assume that the filter is blocking the flow of oil. Since the filter is now suspect the installer will install a second filter. Sometimes this solves the problem because the trapped air was released when the first filter was removed. Of course, the installer's suspicion that the oil filter was at fault has increased.

The point being made is the oil filter was not the problem and in most cases there is a simple solution.

If after the oil and filter change, the red light or low oil pressure remains for ten seconds, shut the engine off, remove the oil filter and, using an oil squirt can with 30 weight motor oil, squirt oil several times into the oil filter base outlet on the engine. (This will be the opening beside the threaded stud; it will not do any good to squirt oil into the threaded stud.) Next, fill the filter with new motor oil and reinstall. Start the engine and check for oil pressure. In most cases the problem will be solved. DO NOT allow the engine to run for more than ten seconds without oil pressure. Use a watch to time the ten seconds and be sure of the elapsed time. In some instances the full ten seconds is needed for the pump to recover oil flow. If this fails, again remove the filter and crank the engine until oil spills from the engine base. DO NOT crank the oil level and restart the engine. Oil pressure should now be back to normal.

Note: Sometimes this problem can be avoided by limiting the time the oil is drained.

Perdida de empuje de la bomba de aceite

Uno de los hechos más confusos que debe enfrentar todo aficionado a la mecánica o mecánico profesional, es la dificultad para conseguir que la presión de aceite vuelva a sus valores normales de operación inmediatamente después de un cambio de aceite.

Aunque esto no es muy común, es posible que la bomba de aceite pierda su empuje durante el cambio de aceite.

Cuando se drena el aceite usado del motor, puede también drenarse aceite del tubo de recolección de la bomba de aceite, y posiblemente de la bomba de aceite misma. Cuando se instala el nuevo aceite de motor, la entrada del tubo de recolección de la bomba queda nuevamente sumergida, quedando así aire atrapado en el tubo en el lado de succión de la bomba de aceite. El aire atrapado causará cavitación en la bomba, e impedirá que la misma produzca la circulación, y la presión, de aceite.

Muchos instaladores tienden a culpar de esto al filtro de aceite, suponiendo que es el filtro el que bloquea la circulación de aceite. Dado que ahora el filtro está bajo sospecha, el instalador colocará un segundo filtro. En algunas ocasiones esto resuelve el problema, debido a que el aire atrapado fue liberado al quitar el primer filtro. Por supuesto, la sospecha del instalador de que el filtro de aceite tenía una falla parece confirmarse.

Es importante tener en cuenta que el filtro de aceite no era el problema, y que en la mayoría de los casos hay una solución simple.

Si luego del cambio de aceite y filtro la luz roja de baja presión de aceite permanece encendida por diez segundos, apague el motor, quite el filtro de aceite y, usando una jeringa de aceite cargada con aceite de motor grado 30, haga chorrear aceite varias veces dentro del orificio de salida de la base del filtro de aceite, situado en el motor. (Debe ser en la abertura que está junto al perno roscado; no es conveniente echar aceite en la rosca misma). Luego, llene el filtro con nuevo aceite de motor, y reinstálelo. Arranque el motor y verifique la presión de aceite. En la mayoría de los casos el problema habrá quedado resuelto. NO permita que el motor funcione por más de diez segundos sin presión de aceite. Use un cronómetro para controlar los diez segundos, asegurándose exactamente del tiempo transcurrido. En algunos casos se necesitan los diez segundos completos para que la bomba haga reanudar la circulación de aceite. Si esto fallara, quite nuevamente el filtro y arranque el motor hasta que el aceite se derrame de la base del motor. NO haga durar esta maniobra más de diez segundos por vez. Cuando el aceite se haya derramado, reinstale el filtro de aceite, corrija el nivel de aceite y vuelva a arrancar el motor. La presión de aceite debe haber vuelto ahora a su valor normal.

Nota: A veces puede evitarse este problema limitando el tiempo de drenaje del aceite.

Perte d'amorçage de pompe à huile

Immédiatement après un remplacement d'huile, un des problèmes les plus troublants à affronter pour le mécanicien bricoleur ou professionnel est l'impossibilité de ramener la pression d'huile dans sa plage normale de fonctionnement. Bien que cela ne soit pas systématique, il est fort possible que la pompe à huile se désamorçe pendant la vidange de l'huile.

Quand l'huile moteur usagée est vidangée du moteur, il se peut qu'elle se vidange aussi du tube plongeur de la pompe à huile, et éventuellement de la pompe elle-même. Quand une nouvelle huile moteur est versée, le tube plongeur devient submergé et de l'air est emprisonné dans le tube du côté de l'aspiration de la pompe à huile. Cet air prisonnier va créer une cavitation dans la pompe et l'empêcher de débiter l'huile, d'où une montée en pression insuffisante.

Beaucoup d'installateurs ont tendance à blâmer pour cela le filtre à huile, en pensant que c'est lui qui bloque le débit d'huile. Comme le filtre est suspecté, l'installateur va le remplacer par un second filtre. Parfois cela solutionne le problème parce que cela peut relâcher de l'air prisonnier en démontant le premier filtre. Et bien sûr la suspicion de l'installateur que le problème venait du filtre s'en trouve renforcée. Ce qu'il faut bien retenir est que le filtre à huile n'est généralement pas la cause du problème et qu'il y a une solution simple pour l'éliminer.

Si après un remplacement d'huile et de filtre, le voyant rouge de pression d'huile basse reste allumé dix secondes après le démarrage moteur, coupez-le, enlevez le filtre à huile, et en utilisant une burette avec de l'huile moteur indice 30, envoyez plusieurs fois de l'huile dans l'orifice de base de filtre à huile du moteur (visez l'ouverture à côté du goujon fileté, il ne sert à rien de mettre de l'huile dans le goujon). Ensuite, remplissez le filtre avec de l'huile moteur et remettez-le en place. Démarrez le moteur et surveillez la pression d'huile. Dans la plupart des cas, le problème aura été solutionné. NE LAISSEZ PAS le moteur tourner plus de dix secondes avec une pression d'huile insuffisante. Utilisez votre montre pour chronométrer avec certitude le temps écoulé après le démarrage. Dans certains cas, il faut ce délai au complet pour que la pompe reprenne son débit normal. Si cela a échoué, enlevez de nouveau le filtre et lancez le moteur jusqu'à ce que de l'huile coule de sa base. NE faites PAS tourner le moteur plus de dix secondes à la fois. Quand l'huile se déverse, remettez le filtre, refaites le niveau d'huile et redémarrez le moteur. La pression d'huile doit être redevenue normale.

Remarque : Parfois, le problème peut être évité en limitant le temps de vidange de l'huile.

Manufacturers' Warranty

Garantías de los Fabricantes

Garantie du fabricant

Consumer purchasers of filters are sometimes told that an aftermarket brand of replacement filter cannot be used in the consumer's vehicle during the warranty period. The claim is made that use of an aftermarket brand will "void the warranty," with the statement or implication that only the original equipment brand of filters may be used. This tends to cast doubt on the quality of the aftermarket filter.

That claim is simply not true. If the consumer asks for the statement in writing, they will not receive it. Nevertheless, the consumer may feel uneasy about using replacement filters that are not original equipment. With the large number of consumers who prefer to use an aftermarket filter this misleading statement should be addressed.

Under the federal Magnuson-Moss Warranty Act, the Clean Air Act and general principles of the U.S. Federal Trade Commission Act, a manufacturer may not require the use of any brand of filter (or any other article) unless the manufacturer provides the item free of charge under the terms of the warranty.

If the consumer is told that only the original equipment filter will not void the warranty, they should request that the OE filter be supplied free of charge. If they are charged for the filter, the manufacturer may be violating the Magnuson-Moss Warranty Act or other applicable law.

By providing this information to consumers, the members of the Filter Manufacturers Council (FMC) intend to combat the erroneous claim that the use of a brand of replacement filter other than original equipment will "void the warranty."

It should be noted that the Magnuson-Moss Warranty Act is a U.S. federal law that applies to consumer products. The U.S. Federal Trade Commission has authority to enforce the Magnuson-Moss Warranty Act, including obtaining injunctions and orders containing affirmative relief. In addition, a consumer can bring suit under the Magnuson-Moss Warranty Act.

Algunas veces, los jefes del departamento mecánico o de servicio de las agencias les dicen a los consumidores que compran filtros automotrices, que no puede usarse, en el vehículo del consumidor, una marca de reemplazo durante el período de garantía. La exigencia es hecha en el sentido de que el uso de tal marca "anulará la garantía" y con la implicación de que sólo la marca original puede ser usada. Esto, por supuesto, tiende a sembrar una duda acerca de la calidad del filtro de reemplazo.

Esto simplemente no es cierto. Si el consumidor pide esto por escrito no lo recibirá. No obstante, el consumidor pudiera no sentirse a gusto al usar filtros de reemplazo que no sean marca original. Con el gran número de consumidores que prefieren hacer ellos mismos el cambio de filtros, esta engañosa exigencia debe ser aclarada.

Bajo el Acta de Garantías Magnuson-Moss y los principios generales del Acta de la Comisión Federal de Comercio, un fabricante no puede exigir el uso de cualquier marca de filtro (o cualquier otro artículo) a menos que el fabricante proporcione el artículo libre de cargo bajo los términos de la garantía.

De esta forma, si al consumidor se le dice que sólo el uso del filtro original no anulará la garantía, él debe exigir que el filtro original sea suministrado sin costo. Si a él se le cobra el filtro, el fabricante del vehículo estará violando el Acta de Garantías Magnuson-Moss u otras leyes aplicables.

Al proporcionar esta información a los consumidores, el FMC puede ayudar a combatir la errónea exigencia de que un filtro de reemplazo, diferente al original, "anulará la garantía".

Debe hacerse notar, que el Acta de Garantías Magnuson-Moss es una ley federal que aplica a productos de consumo. La Comisión Federal de Comercio tiene la autoridad para hacer cumplir el Acta de Garantías Magnuson-Moss, incluyendo la liberación de órdenes. Además, un consumidor puede solicitar un juicio amparado en el Acta de Garantías Magnuson-Moss.

Il arrive parfois chez un concessionnaire automobile qu'un préposé à la clientèle ou un mécanicien dise aux acheteurs de filtres d'automobiles de ne pas utiliser une certaine marque de filtre de rechange sur leur véhicule pendant la période de garantie, à l'effet que l'utilisation de cette marque «annulera la garantie», signifiant ou insinuant ainsi que seul l'emploi de la marque de filtre de l'équipement d'origine est acceptable. Il va sans dire que cette affirmation est de nature à semer le doute sur la qualité des filtres de rechange.

En fait, cette affirmation est tout simplement fausse. Si le consommateur en demandait une version écrite, il n'en recevrait aucune. Cependant, il peut se demander s'il fait un mauvais choix en utilisant des filtres de rechange qui ne sont pas de l'équipement d'origine. Comme il y a un nombre élevé de bricoleurs qui préfèrent poser leurs propres filtres, cette affirmation erronée doit être rectifiée.

Selon la loi sur la garantie Magnuson-Moss Warranty Act et les principes généraux de la U.S. Federal Trade Commission Act, un fabricant ne peut exiger l'utilisation d'une marque de filtre quelconque (ou d'un autre article) à moins d'offrir cet article gratuitement en vertu de la garantie.

Donc, si le consommateur se fait dire que seul le filtre d'équipement d'origine n'annulera pas la garantie, il devrait exiger que ce filtre d'équipement d'origine lui soit offert gratuitement. Si on lui demande de payer ce filtre, le fabricant devient alors en infraction à la loi sur la garantie Magnuson-Moss ou à une autre loi qui s'applique.

En fournissant ce renseignement aux consommateurs, le Conseil des fabricants de filtres désire aider à combattre l'affirmation mensongère qu'une marque de filtre de rechange autre que celle offerte sur l'équipement d'origine «annule la garantie».

Il est important de noter que la loi sur la garantie Magnuson-Moss est une loi fédérale américaine concernant les produits de grande consommation. La U.S. Federal Trade Commission est habilitée à appliquer la loi sur la garantie Magnuson-Moss, y compris à demander des injonctions ou des ordonnances dans lesquelles il y a des mesures réparatrices. De plus, un consommateur peut entamer des poursuites en vertu de la loi sur la garantie Magnuson-Moss.

VALVOLINE OIL FILTERS

Valvoline™ knows clean, quality engine oil is essential to the life of the engine. As one of the few motor oil companies to offer a comprehensive filter line, we understand the importance the oil filter makes in the life of your vehicle.

An oil filter is essential to keeping the vehicle's engine supplied with clean, lifesaving lubricating oil. While engine oil keeps the moving parts in an engine lubricated, the oil filter stops harmful dirt and contaminants from circulating in the oil system, which can cause premature wear and damage. The oil filter not only traps these particles, but it contains them, ensuring a continuous and clean oil flow to your engine.

VALVOLINE OIL FILTERS MEET THE OE FIT AND FUNCTION REQUIREMENTS FOR OVER 97% OF VEHICLES ON THE ROAD TODAY.

VALVOLINE AIR FILTERS

Dirty, clogged air filters choke off vital engine air which the combustion process needs to make power most efficiently. A new Valvoline Air Filter can help increase airflow, horsepower, fuel efficiency, and improve overall engine performance and longevity. Valvoline Air Filters help prevent harmful debris from entering the engine through the air intake system.

VALVOLINE AIR FILTERS ARE GUARANTEED* TO MEET THE OE FIT AND FUNCTION REQUIREMENTS FOR OVER 95% OF VEHICLES.

VALVOLINE CABIN AIR FILTERS

DID YOU KNOW AIR QUALITY INSIDE A VEHICLE CAN BE WORSE THAN THE OUTSIDE AIR?

Poorly maintained heating, air conditioning and vent systems can have the effect of concentrating contaminants inside the passenger cabin. Valvoline Cabin Air Filters work with the vehicle's HVAC system to trap dust, pollen, pet dander, dust mites and their feces, many bacteria, auto exhaust, mold spores and other airborne contaminants to stop them from entering the passenger compartment. Valvoline Cabin Air Filters also help prevent leaves, bugs and other debris from entering the HVAC system.

VALVOLINE CABIN AIR FILTERS MEET THE QUALITY OE FIT AND FUNCTION REQUIREMENTS FOR OVER 95% OF VEHICLES EQUIPPED WITH A CABIN AIR FILTER.

HOW DO OIL FILTERS WORK?

1. Oil filter quality is measured in two primary ways

The total design is a balance of high efficiency and capacity to meet OE recommended drain intervals. Capacity is important for determining the drain interval. The higher capacity, the longer the filter will work. Efficiency and capacity are equally important and are the inverse of each other. For example, a less efficient filter allows for greater capacity but it lowers the engine protection. Valvoline filters protect engines from the harmful particles that can cause engine damage by using high quality synthetic blended media with 94% efficiency at 20 microns.

2. What are filters protecting?

Dirt particles in the 10-20 micron range may be tiny, but can do serious damage to bearings, cylinders, and other engine parts. Dirt particles are the #1 enemy for gasoline engines!

TOP REASONS TO RECOMMEND / REPLACE AN AIR FILTER:

1. Help the engine breathe easier

Clogged filters can choke off the air flow to the engine which causes it to work harder to perform. Long-term, hampered air flow may cause engine wear and costly repairs. A new Valvoline Air Filter helps filter out road debris, leaves, water, bugs, and improves air flow and quality to the engine.

2. Help the vehicle perform better

Dirty air filters create an incorrect air-fuel mixture which may lead to fouled spark plugs resulting in hesitations, engine misses and rough idle. In older vehicles with carburetors, this fouling can reduce fuel economy. Improving air flow to the engine allows it to operate properly.

TOP REASONS TO RECOMMEND / REPLACE A CABIN AIR FILTER:

1. Help the customer breathe easier

A new Valvoline Cabin Air Filter helps improve the air quality in the passenger cabin by filtering the air of known allergens such as dust, pollen and debris (1 micron or larger). A dirty cabin air filter can cause musty odors and allow contaminants to become so concentrated that passengers breathe in more fumes and particles than normal.

2. Help the vehicle perform better

When a cabin air filter becomes clogged or reaches capacity, it may pass less air through the filter to the HVAC. A lowered air flow negatively impacts the performance of heating and cooling and may impact the life span of the entire HVAC system. Just like the filter in a home's HVAC, cabin air filters need to be changed regularly to keep the system functioning properly.

* Valvoline filters meet OE recommended drain intervals regardless of make, model, or year of the vehicle. Valvoline guarantees workmanship on all of its filters.



FILTER HOTLINE:

PHONE: 1-800-TEAM-VAL

EMAIL: productsupport@valvoline.com

HOURS:

Monday - Friday 7:30a – 10:00p

Saturday 7:30a – 9:00p

Sunday 9:00a – 8:00p

Eastern Standard Time

www.valvolinefilters.com

www.valvoline.com

Minimum Information Required: Year, Make, Model, Engine

VALVOLINE'S SERVICE PARTS APP AVAILABLE:

