

An aerial photograph of New York City, showing a dense urban landscape with numerous skyscrapers and buildings. A semi-transparent blue rectangular overlay covers the central portion of the image, serving as a background for the title text.

2020 NYC ENERGY CONSERVATION CODE HOW-TO GUIDE

Duncan Brown, RA, CEM
Jean Kim, RA, CEM, CPHD, LEED AP BD+C



Course no. **S060121**

Title **2020 NYC Energy Conservation Code How-to Guide**

Date **August 26, 2021**

Presented by **Duncan Brown, RA, CEM**
Jean Kim, RA, CEM, CPHD, LEED AP BD+C

Copyright Materials

This presentation is protected by US and International Copyright laws. Reproduction, distribution, display and use of the presentation without written permission of the speaker is prohibited.

© 2021 New York City Department of Buildings



Course Description

This course will review the 2020 NYCECC and the Supporting Documentation How-to Guide with regards to compliance requirements and common questions received by the NYC Department of Buildings Energy Code subject matter experts (submitted to energycode@buildings.nyc.gov). The presentation will focus on new envelope requirements, clarifying mechanical and lighting control mandates, along with significant information published through Buildings Bulletins.

The 2020 NYCECC - Supporting Documentation How-to Guide is available on the DOB website:

https://www1.nyc.gov/assets/buildings/pdf/h2g_all_2020_nycecc.pdf

The Buildings Bulletins are available on:

<https://www1.nyc.gov/site/buildings/codes/building-bulletins.page>

Learning Objectives

1. Participants will review the scope of the Supporting Documentation How-to Guide for the 2020 NYC Energy Conservation Code in order to provide a better understanding of compliance requirements with the 2020 NYCECC, which impacts the health and welfare of building occupants.
2. Participants will review and be able to identify major changes between the 2016 NYCECC and 2020 NYCECC that will affect the safety and welfare of building occupants.
3. Participants will review compliance documentation requirements for envelope, lighting, and mechanical through examples.
4. Participants will identify NYCECC reference materials on the Department of Buildings Website that will aid in improving their design submissions and the safety and welfare of building occupants and the surrounding neighborhood.

SPANDRELS

Spandrel panel: an opaque assembly within a fenestration framing system in a wall that is part of the building thermal envelope. Such panels are considered to be a portion of the opaque thermal envelope assembly.

(Appendix CA – Definitions)

SPANDREL PANEL EFFECTIVE U-FACTORS

TABLE C402.1.4.2
EFFECTIVE U-FACTORS FOR SPANDREL PANELS^a

FRAME TYPE	SPANDREL PANEL	RATED R-VALUE OF INSULATION BETWEEN FRAMING MEMBERS						
		R-4	R-7	R-10	R-15	R-20	R-25	R-30
Aluminum without Thermal Break ^b	Single glass pane, stone, or metal panel	0.242	0.222	0.212	0.203	0.198	0.195	0.193
	Double glass with no low-e coatings	0.233	0.218	0.209	0.202	0.197	0.194	0.192
	Triple or low-e glass	0.226	0.214	0.207	0.200	0.196	0.194	0.192
Aluminum with Thermal Break ^c	Single glass pane, stone, or metal panel	0.211	0.186	0.173	0.162	0.155	0.151	0.149
	Double glass with no low-e coatings	0.200	0.180	0.170	0.160	0.154	0.151	0.148
	Triple or low-e glass	0.191	0.176	0.167	0.159	0.153	0.150	0.148
Structural Glazing ^d	Single glass pane, stone, or metal panel	0.195	0.163	0.147	0.132	0.123	0.118	0.114
	Double glass with no low-e coatings	0.180	0.156	0.142	0.129	0.122	0.117	0.114
	Triple or low-e glass	0.169	0.150	0.138	0.127	0.121	0.116	0.113
No framing or Insulation is Continuous ^e	Single glass pane, stone, or metal panel	0.148	0.102	0.078	0.056	0.044	0.036	0.031
	Double glass with no low-e coatings	0.136	0.097	0.075	0.054	0.043	0.035	0.030
	Triple or low-e glass	0.129	0.093	0.073	0.053	0.042	0.035	0.030

C402.1.4.2
5.5.3

- NOTE 1: To demonstrate compliance, provide COMcheck envelope analysis by:
 - entering the Proposed Spandrel panel U-factor value identified from the Table C402.1.4.2; and
 - choosing the Baseline U-factor of metal-framed walls (U-0.061).
- NOTE 2: If the Proposed Spandrel panel type is not found in the Table - e.g., Assembly with backpans, Assembly with no insulation - THERM Analysis must be performed and documented on drawings.

Info for THERM is found in the link below.
<https://windows.lbl.gov/software/therm>

**6" mineral wool
@ R-4.2 an inch**

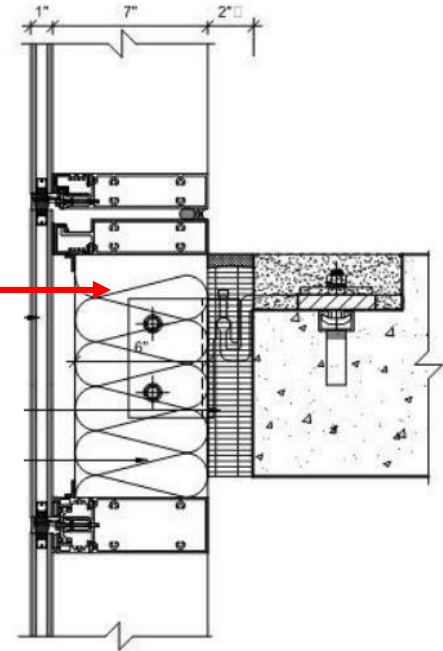

**TABLE C402.1.4.2
EFFECTIVE U-FACTORS FOR SPANDREL PANELS^a**

FRAME TYPE	SPANDREL PANEL	RATED R-VALUE OF INSULATION BETWEEN FRAMING MEMBERS						
		R-4	R-7	R-10	R-15	R-20	R-25	R-30
Aluminum without Thermal Break ^b	Single glass pane, stone, or metal panel	0.242	0.222	0.212	0.203	0.198	0.195	0.193
	Double glass with no low-e coatings	0.233	0.218	0.209	0.202	0.197	0.194	0.192
	Triple or low-e glass	0.226	0.214	0.207	0.200	0.196	0.194	0.192
<u>Aluminum with Thermal Break^c</u>	Single glass pane, stone, or metal panel	0.211	0.186	0.173	0.162	0.155	0.151	0.149
	Double glass with no low-e coatings	0.200	0.180	0.170	0.160	0.15	0.151	0.148
	Triple or low-e glass	0.191	0.176	0.167	0.159	0.153	0.150	0.148
Structural Glazing ^d	Single glass pane, stone, or metal panel	0.195	0.163	0.147	0.132	0.123	0.118	0.114
	Double glass with no low-e coatings	0.180	0.156	0.142	0.129	0.122	0.117	0.114
	Triple or low-e glass	0.169	0.150	0.138	0.127	0.121	0.116	0.113
No framing or Insulation is Continuous ^e	Single glass pane, stone, or metal panel	0.148	0.102	0.078	0.056	0.044	0.036	0.031
	Double glass with no low-e coatings	0.136	0.097	0.075	0.054	0.043	0.035	0.030
	Triple or low-e glass	0.129	0.093	0.073	0.053	0.042	0.035	0.030

Aluminum with Thermal Break^c	Single glass pane, stone, or metal panel	0.211	0.186	0.173	0.162	0.155	0.151	0.149
	Double glass with no low-e coatings	0.200	0.180	0.170	0.160	0.15	0.151	0.148
	Triple or low-e glass	0.191	0.176	0.167	0.159	0.153	0.150	0.148

Component	Assembly	Building Area Type	Orientation	Fenestration Details	Construction Details	Gross Area or Slab Perimeter	Units	Cavity Insulation R-Value	Continuous Insulation R-Value	U-Factor	UA	SHGC
▼ Building												
▼ Regular Opaq	Steel-Framed, 16" o.c.	1 - Multifamily ...	North			1000	ft2	20.0	10.0	0.052	5	
Window 1	Curtain Wall:Fixed			Product ID: Gene... ---		900	ft2			0.400	360	0.30
Spandrel Panel	Other Steel Framed Wall	1 - Multifamily ...	North			200	ft2			0.151	30	

Assembly

Assembly	Gross Area or Perimeter	Cavity R-Value	Cont. R-Value	Proposed U-Factor	Budget U-Factor ^(a)
----------	-------------------------	----------------	---------------	-------------------	--------------------------------

NORTH

Regular Opaque Wall: Steel-Framed, 16" o.c., [Bldg. Use 1 - Multifamily]	1000	20.0	10.0	0.052	0.061
Window 1: Curtain Wall:Fixed, Perf. Specs.: Product ID Generic, SHGC 0.30, < 95' above-grade, [Bldg. Use 1 - Multifamily] (c)	900	---	---	0.400	0.360
Spandrel Panel: Other Steel Framed Wall, [Bldg. Use 1 - Multifamily] (b)	200	---	---	0.151	0.061

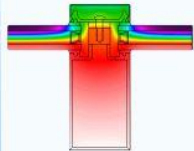

THERM

THERM's two-dimensional conduction heat-transfer analysis is based on the finite-element method, which can model the complicated geometries of building products.

[Therm - https://windows.lbl.gov/software/therm](https://windows.lbl.gov/software/therm)

OVERVIEW

WINDOW

THERM

- Download
- Documentation
- Knowledge Base
- Forum

COMPEN

Two-Dimensional Building Heat-Transfer Modeling

THERM is a state-of-the-art computer program developed by building component manufacturers, engineers, educators, and researchers. With THERM, you can model two-dimensional heat-transfer through roofs, doors, and windows; appliances; and other products when you need to evaluate a product's energy efficiency and local condensation, moisture damage, and structural integrity.

THERM's two-dimensional conduction heat-transfer analysis is based on the finite-element method, which can model the complicated geometries of building products.

THERM can be used with the Berkeley Lab WINDOW program for optical and thermal models to determine total window energy performance. THERM can also be used, in turn, with the RESFEN program, which calculates energy efficiency.

Sample Screen Shots

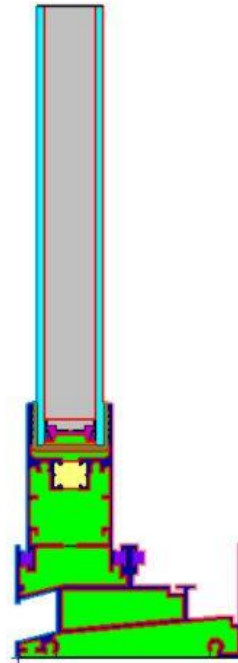

Sample Cross Section
(Aluminum Slider Window Frame)

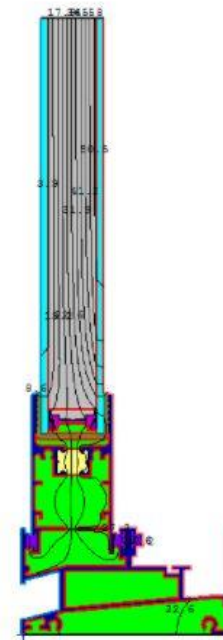

Sample Isotherm Results
(Aluminum Slider Window Frame)

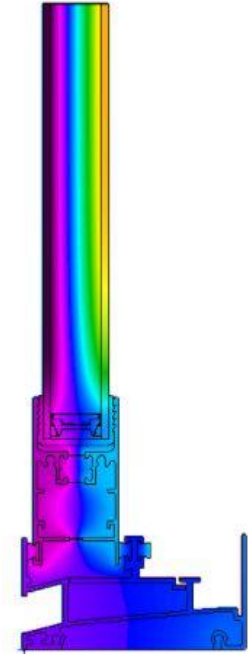

Sample Color Infrared Results
(Aluminum Slider Window Frame)

***Less than R-4 or
Includes a backpan =
Therm documentation
required.***

AIR LEAKAGE TESTING

C402.5.1.3 Air barrier testing. New buildings and additions of a certain size must comply with the following requirements and the rules of the department:

1. New buildings and additions 10,000 square feet (929 m²) and greater, but less than 50,000 square feet (4 645.2 m²), and less than or equal to 75 feet (22.86 m) in height must show compliance through testing in accordance with ASTM E779 or other approved standards. R-2 buildings may alternatively show compliance through testing in accordance with Section R402.4.1.3 of this code.
2. New buildings and additions 10,000 square feet (929 m²) and greater, but less than 50,000 square feet (4 645.2 m²), and greater than 75 feet (22.86 m) in height, shall test or inspect each type of unique air barrier joint or seam in the building envelope for continuity and defects, as per an Air Barrier Continuity Plan developed by a registered design professional. Alternatively, such buildings and additions may show compliance through testing in accordance with Item 1 of this section.
3. New buildings and additions 50,000 square feet (4 645.2 m²) and greater shall test or inspect each type of unique air barrier joint or seam in the building envelope for continuity and defects, as per an Air Barrier Continuity Plan developed by a registered design professional. Alternatively, such buildings and additions may show compliance through testing in accordance with Item 1 of this section.

Reference:
BUILDING ENVELOPE [BE - 8]

<input type="checkbox"/>	<input type="checkbox"/>	Air barrier – visual inspection	(IA6), (IIA6)
<input type="checkbox"/>	<input type="checkbox"/>	Air barrier – testing	(IA7), (IIA7)
<input type="checkbox"/>	<input type="checkbox"/>	Air barrier continuity plan testing/inspection	(IIA8)

▪ **Commercial Buildings** – See C202 for the definition of Commercial Building

1 RCNY §5000-01 (g)(5)(iv)

Building types	Required Testing/Inspection	Required Progress Inspections	Reference code
• New buildings with conditioned space < 10,000 sf	(A)	IIA6	1 RCNY §5000-01 (g)(5)(iv) 5.9
• New buildings with conditioned space ≥ 10,000 sf and < 50,000 sf, and Height ≤ 75'	(A) AND (E)	IIA6 AND IIA7	C402.5.1.3 5.4.3.1.3 5.9
• R-2 occupancy Only: New Buildings with conditioned space ≥ 10,000 sf and < 50,000 sf, and Height ≤ 75'	(A) AND (E) or (D)	IIA6 AND IIA7	C402.5.1.3 5.4.3.1.3 5.9
• New buildings with conditioned space ≥ 10,000 sf and < 50,000 sf, and Height > 75'	(A) AND (F) or (D) or (E)	IIA6 AND IIA8 or IIA7	C402.5.1.3 5.4.3.1.3 5.9
• New buildings with conditioned space ≥ 50,000 sf			
• R-3 occupancy Only: all New Buildings	(A) AND (B) or (C)	IIA6 AND IIA7	C401.2.1

TR-8 Inspections

1. 10k < 50k sf
 < 75' (7-8 stories)
 = Visual and Testing – IIA6 + IIA7

2. R-2 occupancy only
 10k < 50k sf
 < 75' (7-8 stories)
 = Visual and Testing, or Sampling- IIA6 + IIA7

3. 10k < 50k sf
 > 75' (7-8 stories)
 = Visual and ABC Plan, or Sampling, or Testing
 – IIA6 + IIA8 or IIA7

4. > 50k sf
 = Visual and ABC Plan, or Sampling, or Testing
 – IIA6 + IIA8 or IIA7

Air Barrier Continuity Plan

(F) Testing/Inspection conducted per Air Barrier Continuity (ABC) Plan

Air Barrier Continuity Plan must be developed to specify the below.

- List (Schedule of Details) of each unique assembly, joint, seam and penetration, keyed to building thermal/air boundary section diagrams (on Architectural Plans)
 - Testing/Inspection standards (e.g., ASTM E1186) and performance criteria for each assembly, joint, seam and penetration type (on Architectural Plans)
 - Specifications of sealing (continuity-ensuring) materials/measures and Remediation procedures
 - Sampling protocol, if applicable, and Test reporting/submittal guidelines
- ABC Plan, and Final Reports of Testing/Inspection conducted per the ABC shall be provided to DOB upon request

**TABLE R402.4.1.1
AIR BARRIER AND INSULATION INSTALLATION^a**

COMPONENT	AIR BARRIER CRITERIA	INSULATION INSTALLATION CRITERIA
General requirements	<p>A continuous air barrier shall be installed in the building envelope.</p> <p>The exterior thermal envelope shall contain a continuous air barrier.</p> <p>Breaks or joints in the air barrier shall be sealed.</p>	<p>Air-permeable insulation shall not be used as a sealing material. Insulation installed in a cavity must uniformly fill each cavity side-to-side and top-to-bottom, without substantial gaps or voids around obstructions, and shall be split or fitted tightly around wiring and other penetrations in the cavity. Not more than 2 percent of the total insulated area shall be compressed below the thickness required to attain the labeled R-value or contain gaps or voids in the insulation.</p>
Ceiling/attic	<p>The air barrier in any dropped ceiling or soffit shall be aligned with the insulation and any gaps in the air barrier shall be sealed.</p> <p>Access openings, drop down stairs or knee wall doors to unconditioned attic spaces shall be sealed.</p>	<p>The insulation in any dropped ceiling/soffit shall be aligned with the air barrier.</p>
Walls	<p>The junction of the foundation and sill plate shall be sealed.</p> <p>The junction of the top plate and the top of exterior walls shall be sealed.</p> <p>Knee walls shall be sealed.</p>	<p>Cavities within corners and headers of frame walls shall be insulated by completely filling the cavity with a material having a thermal resistance, R-value, of not less than R-3 per inch.</p> <p>Exterior thermal envelope insulation for framed walls shall be installed in substantial contact and continuous alignment with the air barrier.</p>

AIR BARRIER COMMISSIONING

C408.4 Air barrier commissioning. For new buildings or additions that are 10,000 gross square feet (929 m²) and greater, prior to passing final inspection, the approved agency shall provide evidence of air barrier commissioning and substantial completion in accordance with the provisions of Sections C408.4.1 through C408.4.3.

C408.4.1 Documentation. Construction documents shall include documentation of the continuous air barrier components included in the design and a field inspection checklist that includes all requirements necessary for maintaining air barrier continuity and durability in accordance with Section C402.5.1.

C408.4.2 Field inspections. Reports from field inspections during project construction showing compliance with continuous air barrier requirements including proper material handling and storage, use of approved materials and material substitutes, proper material and surface preparation, and air barrier continuity shall be provided to the owner and, upon request, to the building official. Air barrier continuity shall be determined by testing or inspecting each type of unique air barrier joint or seam in the building envelope for continuity and defects.

C408.4.3 Report. A Final Commissioning Report indicating compliance with the continuous air barrier requirements shall be provided to the building owner and, upon request, to the building official.

Even though a building (+10,000 sf) may not fall within the requirement for full documentation of an ABC plan, detail components, field inspection checklist and a note as part of the commissioning statement are required.

“We would like to confirm if separate, tandem ‘commissioning’ services are needed for the ‘air barrier’ or can this section of the code be satisfied under the TR-8 inspections per 1 RCNY 5000-01.”

From: [REDACTED]
Sent: [REDACTED]
To: [REDACTED]
Cc: Energy Code (Buildings) <energycode@buildings.nyc.gov>
Subject: RE: 2020 NYCECC - Section C408.4

Good afternoon.

If the TR8 inspection reports satisfy the individual requirements of C408.4, then ‘tandem’ commissioning services would not be required, i.e:

- Documentation of the air barrier components and a completed field inspection checklist.
- Detailed TR-8 Inspection reports.
- A report of same to the owner indicating compliance with the requirements.

Please don’t hesitate to ask if you require any further clarification.

Thank you.

The Energy Code Compliance Team

EnergyCode@buildings.nyc.gov
NEW YORK CITY DEPARTMENT OF BUILDINGS
280 Broadway, 7th Floor • New York, NY 10007

THERMAL BRIDGES

R402.6 Thermal bridges (Mandatory). Applications for construction document approval shall include documentation of thermal bridges.

R402.6.1 Clear field thermal bridges. Where otherwise not included in pre-calculated assembly *U*-factors, *C*-factors, or *F*-factors outlined in Appendix A of ASHRAE 90.1—2016 (as amended), as set forth in Appendix CA of this code, clear field thermal bridges in a wall, roof, or floor assembly shall be noted as such in the drawings.

R402.6.2 Point thermal bridges. Point thermal bridges greater than or equal in area to 8 in² (5161 mm²) and not associated with HVAC or electrical systems shall be noted as thermal bridges in the drawings.

R402.6.3 Linear thermal bridges. Construction documents shall include the following documentation in tabular format for linear thermal bridges listed in Table R402.6:

1. Linear thermal bridge type.
2. Aggregate length of each type of linear thermal bridge.
3. Relevant detail in the construction documents showing a cross-section through the thermal bridge.
4. Ψ -value for each thermal bridge from Table R402.6.

Exception: Where linear thermal bridges have been tested or modeled using methods approved by the department, alternate values may be used as long as supporting documentation is provided.

C402.6 Thermal bridges (Mandatory). Applications for construction document approval shall include the following documentation of thermal bridges:

C402.6.1 Clear field thermal bridges. Where otherwise not included in pre-calculated assembly *U*-factors, *C*-factors, or *F*-factors outlined in Appendix A of ASHRAE 90.1-2016 (as amended), as set forth in Appendix CA of this code, clear field thermal bridges in a wall, roof, or floor assembly shall be noted as such in the drawings.

C402.6.2 Point thermal bridges. Point thermal bridges greater than or equal in area to 12 in² (7744 mm²) and not associated with HVAC or electrical systems shall be noted as thermal bridges in the drawings.

C402.6.3 Linear thermal bridges. Construction documents shall include the following documentation in tabular format for linear thermal bridges listed in Table C402.6:

1. Linear thermal bridge type.
2. Aggregate length of each type of linear thermal bridge.
3. Relevant detail in the construction documents showing a cross-section through the thermal bridge.
4. Ψ -value for each thermal bridge from Table C402.6.

Exception: Where linear thermal bridges have been tested or modeled using methods approved by the department, alternate values may be used.

**TABLE R402.6
AVERAGE THERMAL TRANSMITTANCE
FOR UNMITIGATED LINEAR THERMAL BRIDGES**

TYPE OF THERMAL BRIDGE	Ψ -value ^a [Btu/hr · ft · °F]	Ψ -value ^a W/mK
Steel Frame, Steel Stud, Poured-in-place Concrete, Concrete Block, Curtain-wall		
Balcony	0.50	0.871
Floor ^b	0.44	0.755
Slab to Ground	n/a	n/a
Fenestration Perimeter Transition ^c	0.32	0.550
Parapet	0.42	0.735
Eaves	n/a	n/a
Shelf Angle	0.41	0.713
Wood Frame Construction		
Balcony	n/a	n/a
Floor ^b	0.336	0.582
Slab to Ground	n/a	n/a
Fenestration Perimeter Transition ^c	0.15	0.26
Parapet	0.032	0.056
Eaves	n/a	n/a
Shelf Angle	0.186	0.322

- a. Psi-values are derived from the ASHRAE Research Project 1365 and BC Hydro Building Envelope Thermal Bridging Guide Version 1.2 - September 2018, and are based on poor performing details.
- b. This value is for an intermediate floor. Ground to Slab thermal bridging is applicable for all buildings.
- c. Fenestration Perimeter Transition is the thermal bridge between any fenestration frame and the typical wall, roof or floor assembly it abuts or is mounted within. For each unique window or door installation type, provide a minimum of one typical-installation detail showing either the head, jamb or sill detail of the window or door frame and the abutting wall, roof or floor construction, including all structural and insulation layers, blocking, flashing, and cladding.

**TABLE C402.6
AVERAGE THERMAL TRANSMITTANCE
FOR UNMITIGATED LINEAR THERMAL BRIDGES**

TYPE OF THERMAL BRIDGE	Ψ -VALUE ^a [Btu/hr · ft · °F]
Balcony	0.50
Floor Slab	0.44
Fenestration Perimeter Transition ^b	0.32
Parapet	0.42
Shelf Angle	0.41

- a. Psi-values are derived from the BC Hydro Building Envelope Thermal Bridging Guide Version 1.2—September 2018, and are based on poor performing details.
- b. Fenestration Perimeter Transition is the thermal bridge between any fenestration frame and the typical wall, roof or floor assembly it abuts or is mounted within.

Table 5.4.4 Average Thermal Transmittance for Unmitigated Linear Thermal Bridges

Type of Thermal Bridge	Ψ -value ^a [Btu / hr ft °F]
Balcony	0.50
Floor Slab	0.44
Fenestration Perimeter Transition ^b	0.32
Parapet	0.42
Shelf Angle	0.41

- a. Psi-values are derived from the BC Hydro Building Envelope Thermal Bridging Guide Version 1.2 –September 2018, and are based on poor performing details.
- b. Fenestration Perimeter Transition is the thermal bridge between any fenestration frame and the typical wall, roof or floor assembly it abuts or is mounted within.

THERMAL BRIDGES IN BUILDING ENVELOPE

Documentation of Thermal Bridges

1 RCNY §5000-01
(g)(1)(iii)
R402.6
C402.6
5.4.4

- Architectural plan set drawings must report all thermal bridges in the building thermal envelope in **three categories** below.
- Documentation requirements apply to Residential and Commercial buildings for all New buildings, Additions, and Alterations to the building envelope work scope.

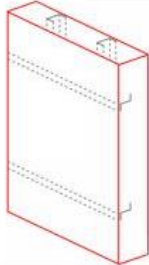
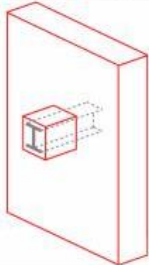
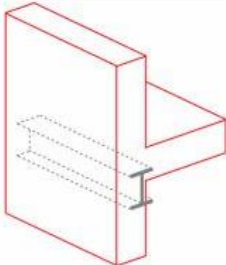
Category	CLEAR FIELD Thermal Bridge	POINT Thermal Bridge	LINEAR Thermal Bridge
Definition	<p>Area-based thermal transmittance associated with elements of a building envelope assembly which repeat at regular intervals.</p> <p>Most clear field thermal bridges are taken into account in the assembly types found in ASHRAE 90.1-2016 Appendix A.</p>	<p>Element-based thermal transmittance associated with a discrete element that penetrates the building envelope.</p> <p>Point thermal transmittance is heat flow divided by the temperature difference between the interior and exterior sides of the assembly, represented by a X-value (Chi-Value) in units Btu/hr • °F.</p>	<p>Length-based thermal transmittance associated with horizontal, vertical, or diagonal elements within the building envelope</p> <p>Linear thermal transmittance is heat flow divided by length and by the temperature difference between the interior and exterior sides of the assembly, represented by a Ψ-value (Psi-Value) in units Btu/hr • ft • °F.</p>
Typical Assemblies	Wall assembly with metal studs, or brick ties, or z-girts	A beam penetrating a wall, A column penetrating a roof or floor, An anchor or connection used to attach an element to the building	Balcony, Floor, Fenestration perimeter transition, Parapet, Floor slab edge, Shelf angle
Sample Illustration			
Documentation Requirements on Architectural Plan Set	<ul style="list-style-type: none"> - List of CLEAR FIELD Thermal Bridges - How they are entered in Envelope energy analysis - Reference section detail locations 	<ul style="list-style-type: none"> - List of POINT Thermal Bridges ≥ 8 in² for Residential buildings, and ≥ 12 in² for Commercial buildings - Size and quantity of each thermal bridge type - Reference section detail locations 	<ul style="list-style-type: none"> - List of LINEAR Thermal Bridges - Ψ-value of each thermal bridge type and its source - Total length of each thermal bridge - How they are entered in Envelope energy analysis - Reference section detail locations

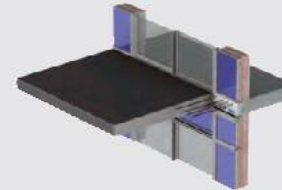
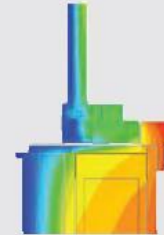
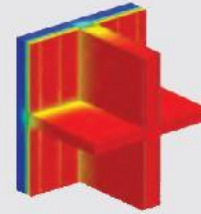

Building Envelope Thermal Bridging Guide

VERSION 1.2

2018



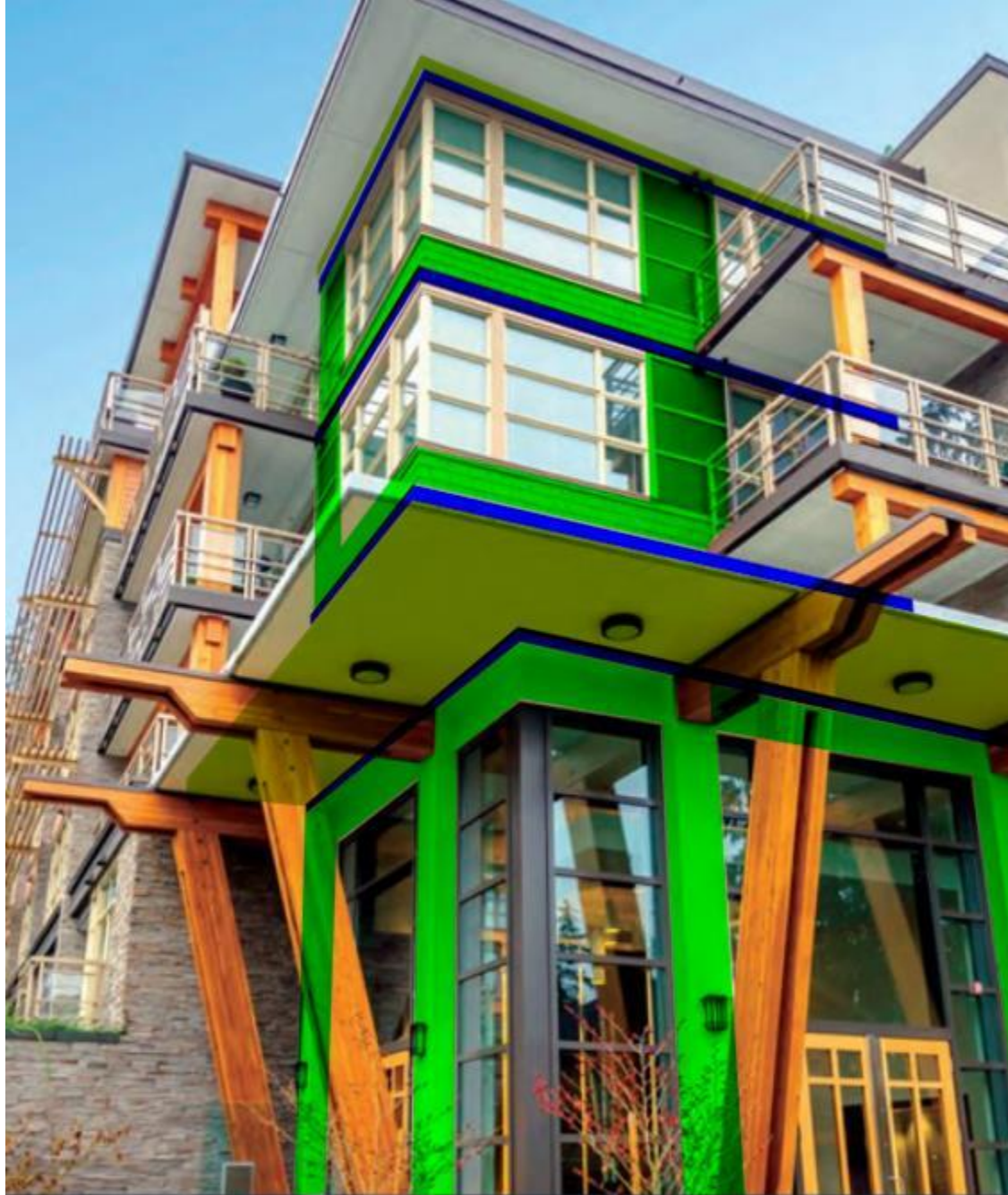



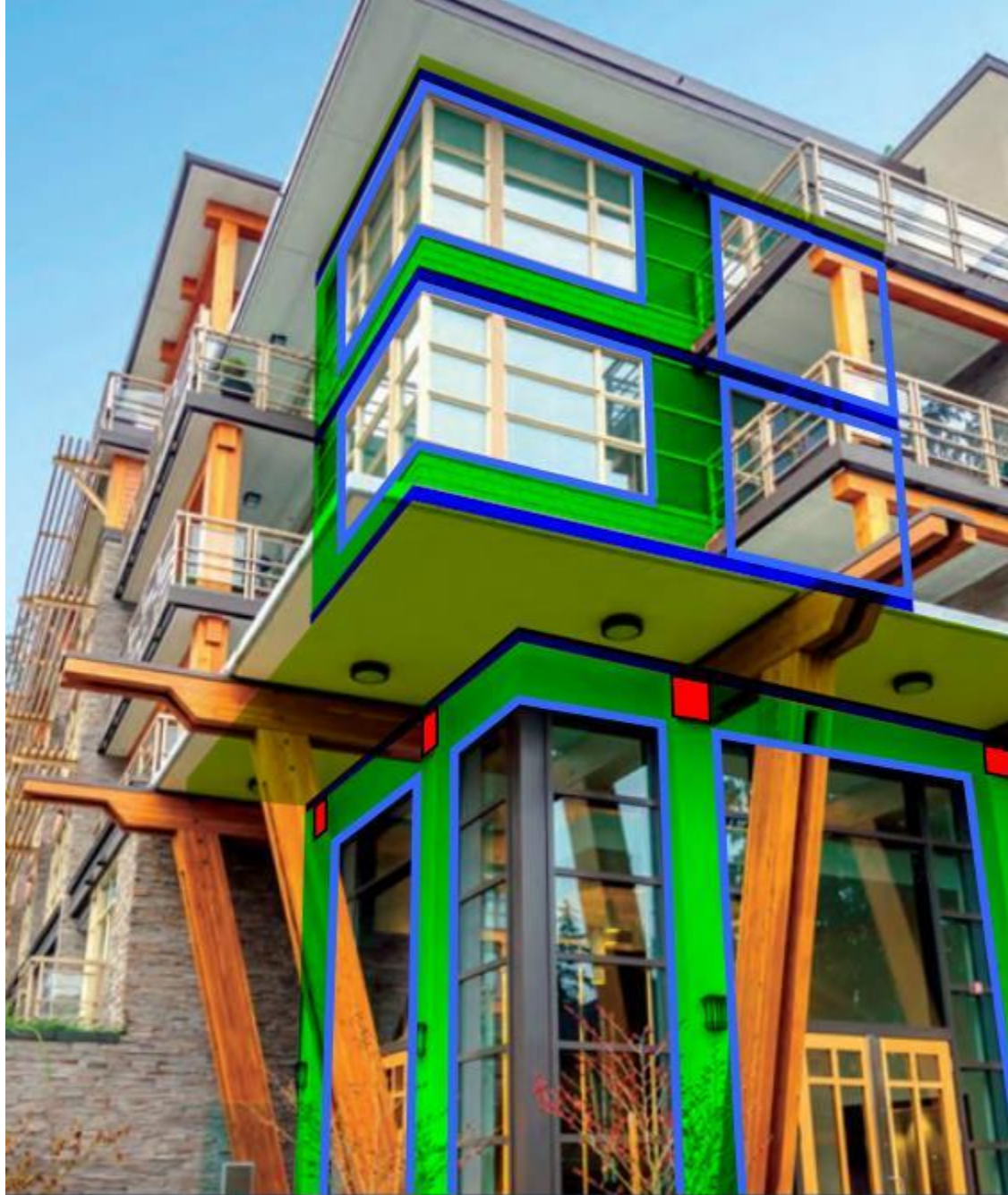

[EXAMPLE] DOCUMENTATION OF THERMAL BRIDGES (REQUIRED IN ARCHITECTURAL PLANS)

CLEAR FIELD Thermal Bridges			
CFTB.no	Assembly/Thermal Bridge Description	Assembly ID in Energy Analysis ¹	Section Detail Location
CFTB.1	Concrete roof deck with R-33ci	RF-1	A-502/4
CFTB.2	Concrete roof deck with R-30ci	RF-2	A-502/5
CFTB.3	CMU wall, EIFS finish	WT-1	A-501/1
CFTB.4	CMU wall, Metal panel cladding	WT-2	A-501/2
CFTB.5	Spandrel wall - Aluminum frame w. thermal break, Single pane glass, Metal panel	WT-3	A-508/4
CFTB.6	Mass floor over parking garage	FL-1	A-503/5
CFTB.7	Mass floor over unconditioned space at courtyard	FL-2	A-503/6

1. Envelope COMcheck report on EN-004

POINT Thermal Bridges				
PTB.no	Assembly/Thermal Bridge Description	Size [sq. inches]	Number of Occurrence	Section Detail Location
PTB.1	Structural beam penetration on walls @ courtyard	14	6	A-502/7
PTB.2	Structural column (pilotis) penetrating 2nd floor slab/soffit @ courtyard	21	4	A-504/1
PTB.3	Main entrance canopy structural member penetration on walls	9	2	A-504/2

LINEAR Thermal Bridges						
LTB.no	Type of Thermal Bridge	Ψ - Value [Btu/hr.ft. °F]	Ψ - Value Source/ Calculation	Total Length [ft]	Assembly ID in Energy Analysis ¹	Section Detail Location
LTB.1	Parapet	0.42	Default value from Table C402.6	284	n/a	A507/1
LTB.2	Balcony	0.45	Ψ - Value of better performing details per BC Hydro Building Envelope Thermal Bridging Guide v.1.2	34	WT-B	A507/7
LTB.3	Floor Slab Edge-1	0.44	Default value from Table C402.6	72	WT-SE1	A507/2
LTB.4	Floor Slab Edge-2	0.40	Ψ - Value of better performing details per BC Hydro Building Envelope Thermal Bridging Guide v.1.2	21	WT-SE2	A507/3
LTB.5	Fenestration Perimeter	0.32	Default value from Table C402.6	617	n/a	A702/1, A702/2, A702/5, A702/6
LTB.6	Shelf Angle	0.41	Default value from Table C402.6	65	n/a	A508/2, A508/3

1. Envelope COMcheck report on EN-004

DOCUMENTING THERMAL BRIDGES IN BALCONY SLAB

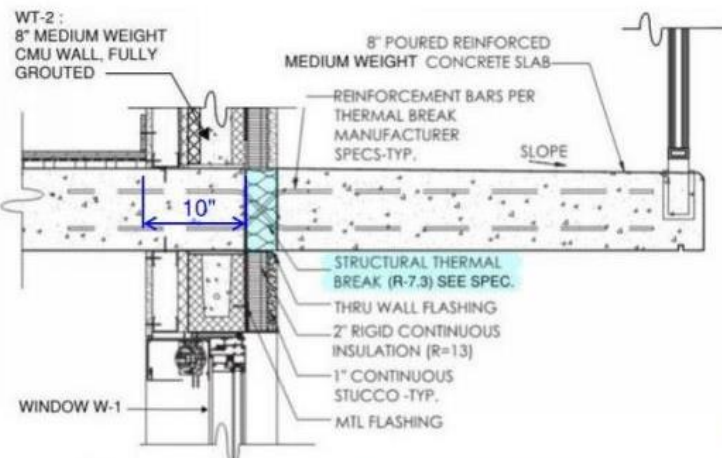

1 BALCONY CONNECTION WITH THERMAL BREAK

Envelope Assemblies

Assembly	Gross Area or Perimeter	Cavity R-Value	Cont. R-Value	Proposed U-Factor	Budget U-Factor _(a)
NORTH					
Exterior Wall 1: Concrete Block:8", Solid Grouted, Medium Density, Furring: None, [Bldg. Use 1 - Multifamily]	3780	---	13.0	0.066	0.086
Window 1: Metal Frame:Fixed, 95' above-grade, Perf. Specs.: Product ID WT1, SHGC 0.36, < 95' above-grade, [Bldg. Use 1 - Multifamily] (b)	580	---	---	0.380	0.300
Window 2: Metal Frame:Fixed, >= 95' above-grade, Perf. Specs.: Product ID WT2, SHGC 0.36, >= 95' above-grade, [Bldg. Use 1 - Multifamily] (b)	720	---	---	0.380	0.360
Slab edge1: Solid Concrete:10" Thickness, Medium Density, Furring: None, [Bldg. Use 1 - Multifamily]	255	---	7.3	0.103	0.086

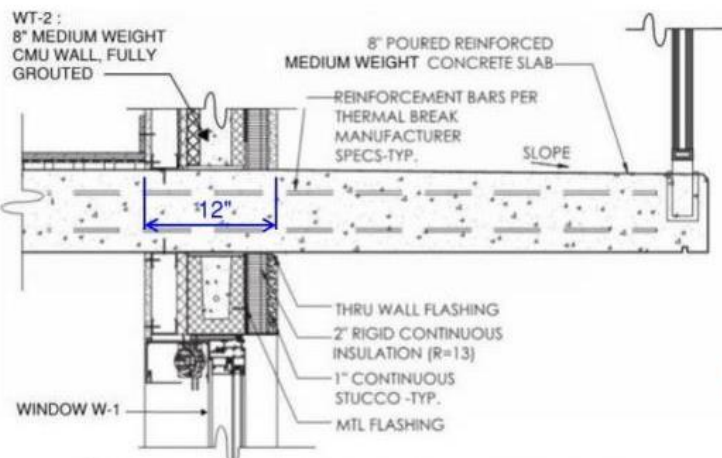

2 BALCONY CONNECTION WITHOUT THERMAL BREAK

Envelope Assemblies

Assembly	Gross Area or Perimeter	Cavity R-Value	Cont. R-Value	Proposed U-Factor	Budget U-Factor _(a)
NORTH					
Exterior Wall 1: Concrete Block:8", Solid Grouted, Medium Density, Furring: None, [Bldg. Use 1 - Multifamily]	3780	---	13.0	0.066	0.086
Window 1: Metal Frame:Fixed, 95' above-grade, Perf. Specs.: Product ID WT1, SHGC 0.36, < 95' above-grade, [Bldg. Use 1 - Multifamily] (b)	580	---	---	0.380	0.300
Window 2: Metal Frame:Fixed, >= 95' above-grade, Perf. Specs.: Product ID WT2, SHGC 0.36, >= 95' above-grade, [Bldg. Use 1 - Multifamily] (b)	720	---	---	0.380	0.360
Slab edge1: Solid Concrete:12" Thickness, Medium Density, Furring: None, [Bldg. Use 1 - Multifamily]	255	---	0.0	0.450	0.086

Figure BE-11. Sample Balcony Edge Details & Matching Envelope COMcheck Reports

ENERGY TRUSS

Approximately
25% of Heat Loss
 Through Roof
 of a Home

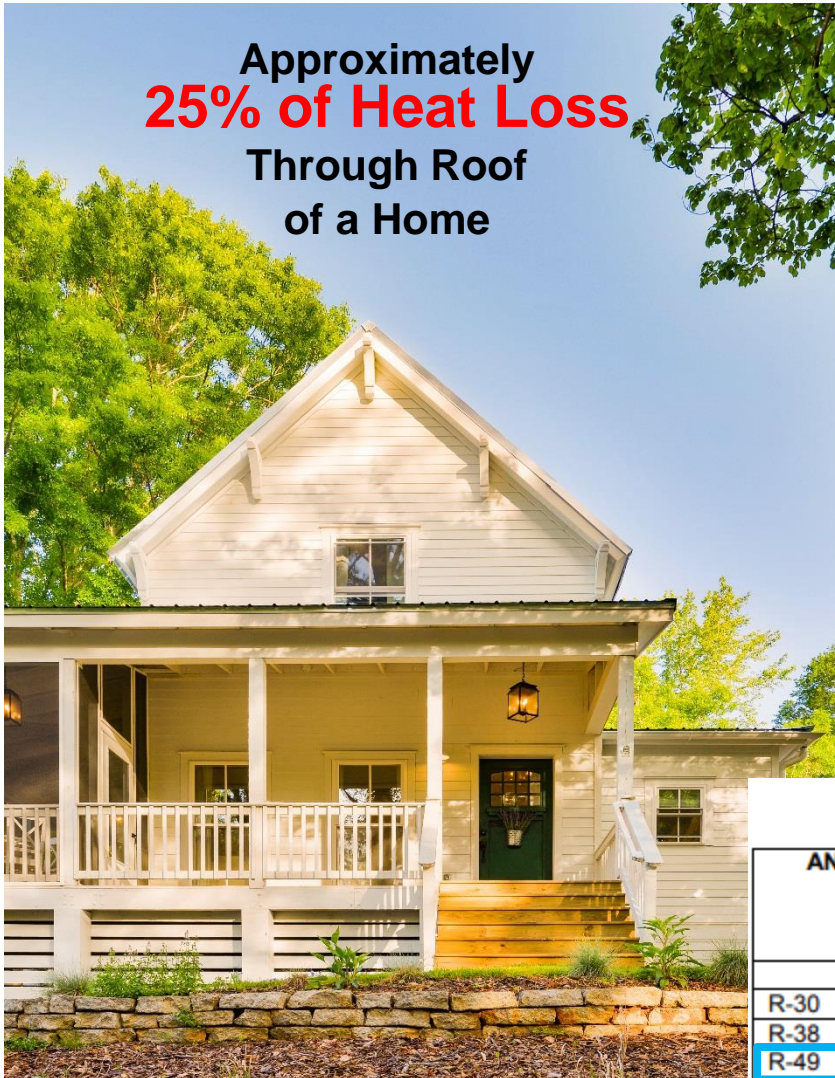

**TABLE R402.1.2
 INSULATION AND FENESTRATION REQUIREMEN**

CLIMATE ZONE	FENESTRATION U-FACTOR ^b	SKYLIGHT ^b U-FACTOR	GLAZED FENESTRATION SHGC ^{b,c}	CEILING R-VALUE	WOOD FRAME WALL R-VALUE	MASS WALL R-VALUE ^d
4	0.27	0.50	0.40	49	20+5 or 13+10 ^h	15/20

**TABLE R402.1.4
 EQUIVALENT U-FACTORS^a**

CLIMATE ZONE	FENESTRATION U-FACTOR	SKYLIGHT U-FACTOR	CEILING U-FACTOR	FRAME WALL U-FACTOR	MASS WALL U-FACTOR
4	0.27	0.50	0.026	0.045	0.0

**TABLE R402.2.6
 STEEL-FRAME CEILING, WALL**

AND FLOOR INSULATION R-VALUES WOOD FRAME R-VALUE REQUIREMENT	COLD-FORMED STEEL-FRAME EQUIVALENT R-VALUE ^a
	Steel Truss Ceilings^d
R-30	R-38 or R-30 + 3 or R-26 + 5
R-38	R-49 or R-38 + 3
R-49	R-38 + 5

Source: basc.pnnl.gov/images

R402.2.1 Ceilings with attic spaces. Where Section R402.1.2 requires R-38 insulation in the ceiling, installing R-30 over 100 percent of the ceiling area requiring insulation shall satisfy the requirement for R-38 wherever the full height of uncompressed R-30 insulation extends over the wall top plate at the eaves. Where Section R402.1.2 requires R-49 insulation in the ceiling, installing R-38 over 100 percent of the ceiling area requiring insulation shall satisfy the requirement for R-49 insulation wherever the full height of uncompressed R-38 insulation extends over the wall top plate at the eaves. This reduction shall not apply to the *U-factor* alternative approach in Section R402.1.4 and the Total UA alternative in Section R402.1.5.

Raised-Heel Truss (a.k.a. Energy Truss)

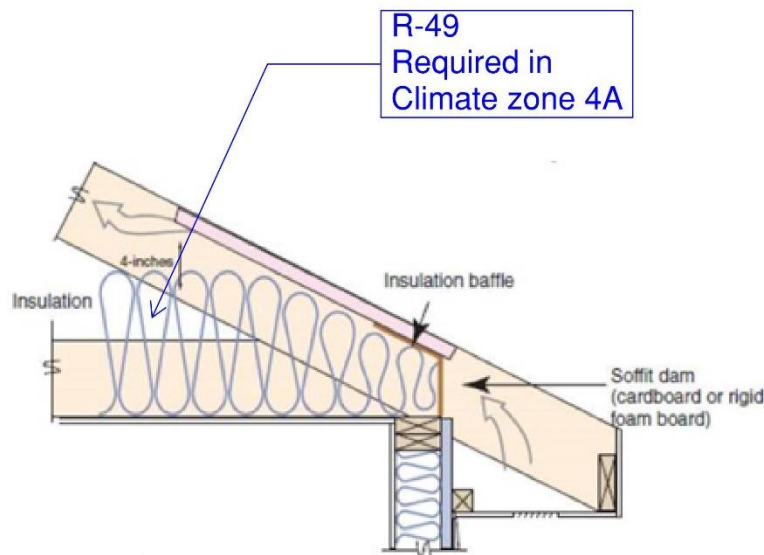

Standard rafter and top plate with tapered insulation depth

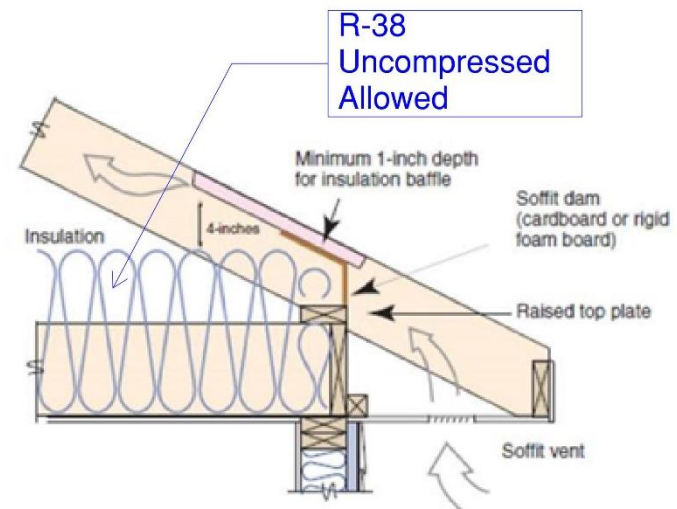

Rafter on raised top plate with full height insulation (recommended)

Source: basf.pnnl.gov/images

RESIDENTIAL BUILDING ENVELOPE

Insulation in Ceilings

- **Ceiling with Attic Spaces:** Minimum R-49; or *Uncompressed R-38* covering 100% of ceiling and extended over the wall top plate at the eaves (See Figures below).
- **Ceiling without Attic Spaces:** When installation of required minimum R-49 insulation in 100% of the ceiling is unachievable, R-38 insulation is allowed for a maximum 500 sf or maximum 20% of the total insulated ceiling area, whichever is less. If partial R-38 insulation is proposed, provide roof area calculations with roof plan diagrams.

R402.2.1
R402.2.2

Access Hatches and Doors

Access doors to unconditioned spaces such as attics and crawl spaces must be weatherstripped and insulated to a level equivalent to the insulation on the surrounding surfaces (e.g., adjacent ceiling surface).

R402.2.4

Sunroom Insulation and Fenestration

- Sunrooms enclosing conditioned space must meet the Residential building envelope insulation and fenestration requirements.
- Sunrooms *with thermal isolation* and enclosing conditioned space must meet the following insulation and fenestration requirements:
 - **Ceiling Insulation:** Min. R-19
 - **Wall Insulation:** Min. R-13
 - **Vertical Fenestration:** Max. U-0.45
 - **Skylight:** Max. U-0.70
- Conditioned space *with thermal isolation* must be controlled as a separate zone for heating and cooling, or conditioned by separate equipment.

R402.2.13
R402.3.5

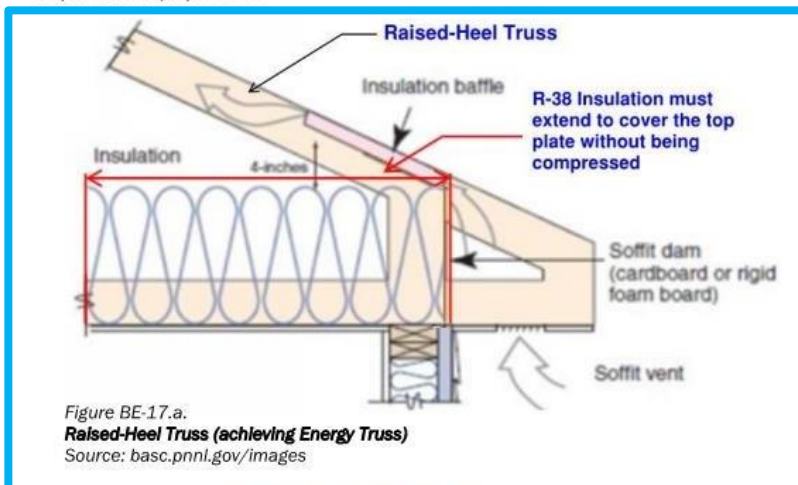

**BALANCED
VENTILATION
SYSTEM**

Reference:

MECHANICAL SYSTEMS [MS - 6]

RESIDENTIAL-BUILDING-SPECIFIC REQUIREMENTS

The relevant construction drawings (e.g., M-, P- labeled drawings) must clearly document – through equipment schedules, notes, narratives, drawings, and/or diagrams, etc. – how the proposed system will comply with the applicable Code requirements, and where the proposed means and measures will be located.

▪ Service Water Heating

- **Heat Trace Temperature Control:** Any electric heat trace systems must be provided with controls that automatically adjust the energy input to the heat tracing to maintain the desired water temperature in response to the occupant's hot water use.
- **Demand Recirculation Systems:** Any *circulation pump* must be equipped with *controls* that automatically start/turn off the pump in response to the hot water demand and water temperature in the system.
- **Insulation:** Hot water pipes must be insulated with a minimum thermal resistance value of R-3.
- **Supply of Heated Water:** Service hot water supply piping must be designed in accordance of with one of the following:
 - (a) Maximum allowable pipe length method
 - (b) Maximum allowable pipe volume method
 - (c) Drain water heat recovery units
 - (d) Recirculation systems

R403.5.1
R403.5.2
R403.5.3
R403.5.5

▪ Ventilation

- **Dampers:** Outdoor air intakes and exhausts must have *automatic or gravity* dampers that close when the ventilation system is not operating.
- **Fan Efficacy:** Fans used to provide whole-house mechanical ventilation must meet or exceed the minimum system efficacies of Table R403.6.1.
- **Ventilation System Design:**

In new Residential buildings, 'exhaust-only' ventilation is No Longer accepted for energy code compliance.
Instead, ventilation system of every dwelling unit must be designed with:

 - (a) Supply and exhaust ventilation with heat recovery ventilator (**HRV**) or energy recovery ventilator (**ERV**), Or
 - (b) Balanced ventilation system satisfying air flow rates of Table R403.6.2(1), and fan capacities adjusted per Table R403.6.2(2).

R403.6

R403.6.1

R403.6.2

Ventilation

- **Dampers:** Outdoor air intakes and exhausts must have *automatic or gravity* dampers that close when the ventilation system is not operating.
- **Fan Efficacy:** Fans used to provide whole-house mechanical ventilation must meet or exceed the minimum system efficacies of Table R403.6.1.
- **Ventilation System Design:**

In new Residential buildings, 'exhaust-only' ventilation is No Longer accepted for energy code compliance.

Instead, ventilation system of every dwelling unit must be designed with:

- Supply and exhaust ventilation with heat recovery ventilator (**HRV**) or energy recovery ventilator (**ERV**), Or
- Balanced ventilation system satisfying air flow rates of Table R403.6.2(1), and fan capacities adjusted per Table R403.6.2(2).

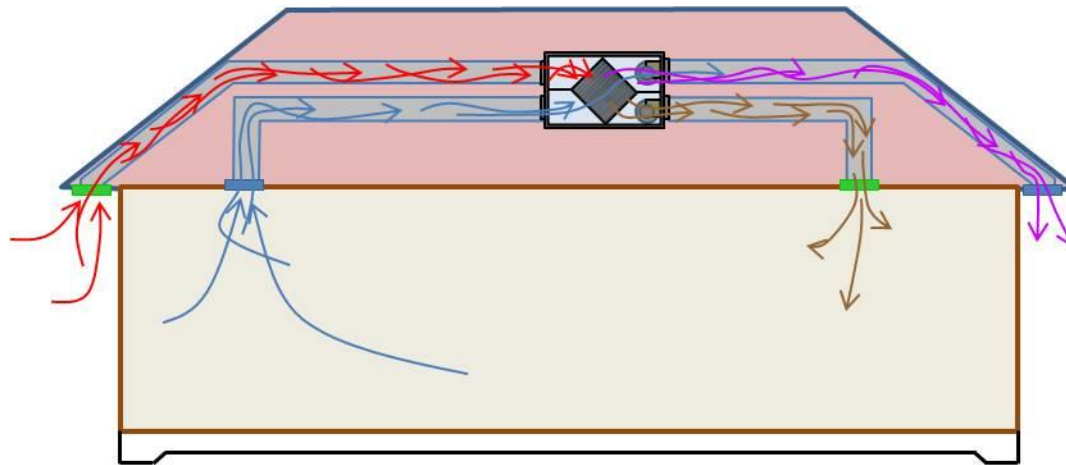

source: <https://basc.pnnl.gov>

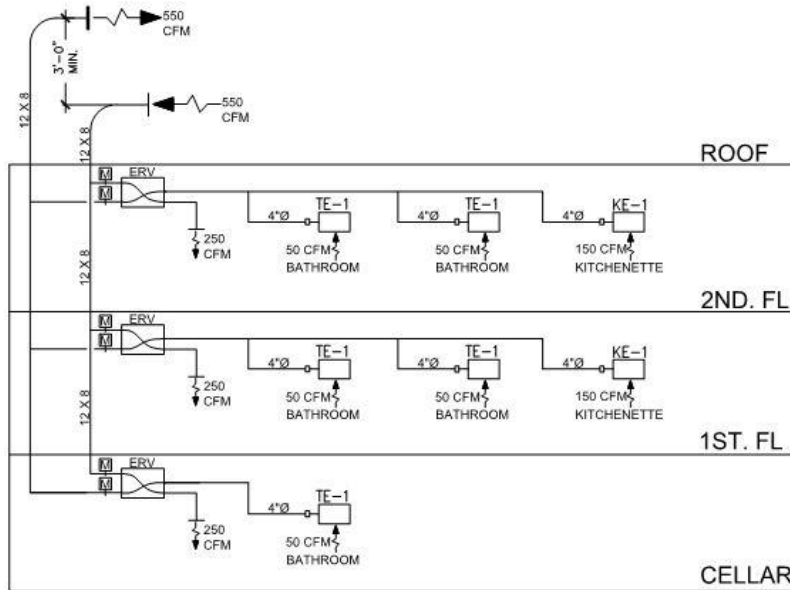

AIR RISER DIAGRAM

SCALE: N.T.S.

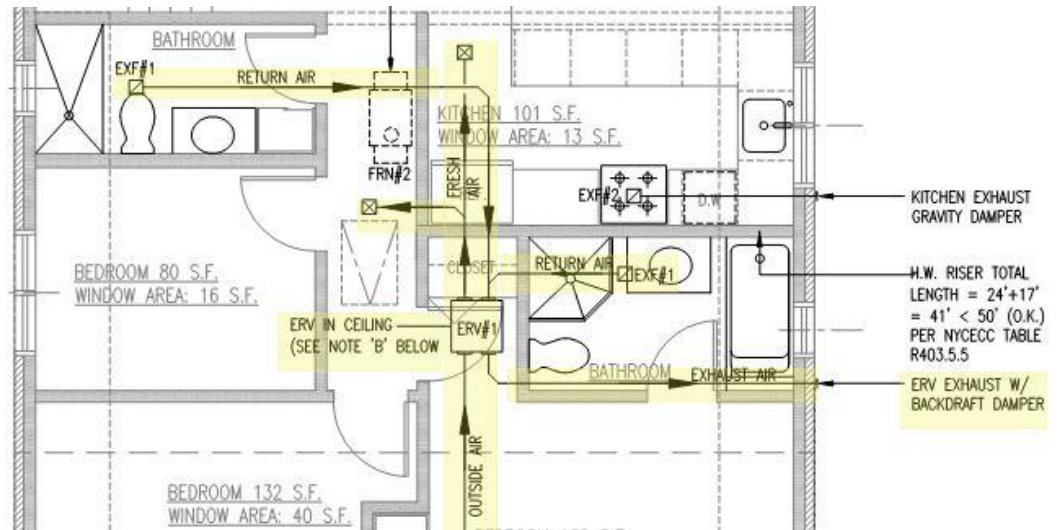
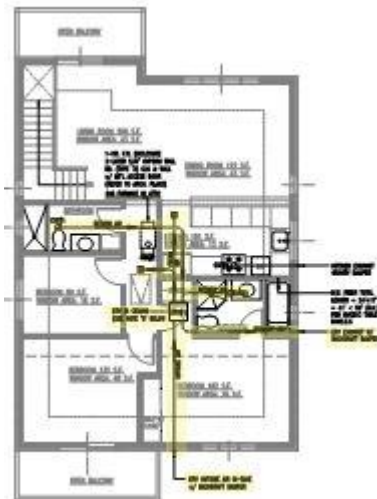

ECONOMIZERS

ECONOMIZERS

The relevant construction drawings (e.g., M-, P- labeled drawings) must clearly document – through equipment schedules, notes, narratives, drawings, and/or diagrams, etc. – how the proposed system will comply with the applicable Code requirements, and where the proposed means and measures will be located.

Requirement for Each Cooling System

- Most commercial buildings have spaces that need cooling all year long. If it is colder outside than inside, economizers provide “free cooling” by bringing in the outdoor air to cool the space in lieu of activating mechanical cooling equipment.
- Air or water economizer must be provided on individual fan-cooling units **≥ 270 kBtu/h for Group R** occupancies, and **≥ 54 kBtu/h for all other** occupancies
- For **ECC-following jobs**:
 - Even if each fan cooling unit serving **Group R** occupancies is < 270 kBtu/h, the total supply capacity of all fan cooling units not provided with economizers must be ≤ 20 % of the total supply capacity, or **1,500 kBtu/h**, whichever is greater.
 - Even if each fan cooling unit serving **all other** occupancies is < 54 kBtu/h, the total supply capacity of all fan cooling units not provided with economizers must be ≤ 20 % of the total supply capacity, or **300 kBtu/h**, whichever is greater.

C403.5
6.5.1

(• NOTE: For split systems or VRF systems, the indoor cooling unit capacity must be used to calculate the total supply capacity.)

High-Efficiency Exemption

- **ECC**-following jobs: Individual cooling systems with minimum **20%** efficiency improvement (IPLV or EER) are exempt from providing economizers.
- **ASHRAE**-following jobs: Individual cooling systems with minimum **42%** efficiency improvement (IPLV, IEER, SEER, or alternatively EER) are exempt from providing economizers.

Table C403.5(2)
Table 6.5.1-2

Cooling Stage Requirements

Cooling systems with economizers are required to have two-, three- or four-stage cooling, depending on the size of the cooling system. The economizers are required to provide partial cooling even if the outdoor air is not cool enough to satisfy the entire cooling load.

C403.5.1

High-Limit Shutoff

Economizers in lieu of mechanical cooling can save energy significantly when the outdoor air is cool and has low humidity. The Code sets the temperature and enthalpy limits when economizers are to shut off; these high-limit shutoffs must be noted in the construction documents.

C403.5.3.3
6.5.1.1.3

Economizer Fault Detection and Diagnostics (FDD)

Systems equipped with an economizer must include a *fault detection and diagnostics* (FDD) system equipped with specific sensors that detect and reports faults.

C403.5.5
6.4.3.12

Requirement for Each Cooling System

- Most commercial buildings have spaces that need cooling all year long. If it is colder outside than inside, economizers provide “free cooling” by bringing in the outdoor air to cool the space in lieu of activating mechanical cooling equipment.
 - Air or water economizer must be provided on individual fan-cooling units ≥ 270 kBtu/h for **Group R** occupancies, and ≥ 54 kBtu/h for **all other** occupancies
 - For **ECC-following jobs**:
 - Even if each fan cooling unit serving **Group R** occupancies is < 270 kBtu/h, the total supply capacity of all fan cooling units not provided with economizers must be ≤ 20 % of the total supply capacity, or **1,500 kBtu/h**, whichever is greater.
 - Even if each fan cooling unit serving **all other** occupancies is < 54 kBtu/h, the total supply capacity of all fan cooling units not provided with economizers must be ≤ 20 % of the total supply capacity, or **300 kBtu/h**, whichever is greater.
- (NOTE: For split systems or VRF systems, the indoor cooling unit capacity must be used to calculate the total supply capacity.)

2016 Code > 300,000 Btu/h for Residential.

PTAC or a heat pump = 12,000 Btu/h > 300,000/ 12,000 = 25 pieces of equipment = 2 pieces an apt means **12 unit** 1 bedroom

2020 Code > 1,500,000 Btu/h for Residential.

PTAC or a heat pump = 12,000 Btu/h > 1,500,000/ 12,000 = 125 pieces of equipment = 2 pieces an apt means **62 unit** 1 bedroom apt building.

For split systems or VRF systems, the indoor cooling capacity has to be used to calculate the total supply capacity. And the limit is 270,000 Btu/h per individual indoor unit without an economizer.

Split or VRF (cooling) = 5,000 Btu/h > 1,500,000/5,000 = 300 pieces of equipment = 2 pieces/apt means **150 unit** 1bdm apt building.

LIGHTING CONTROLS

OCCUPANT SENSOR CONTROLS*

Where Required

- Occupant sensor controls are required in spaces including: classrooms, conference rooms, copy rooms, lounges/ break rooms, enclosed offices, open plan offices, restrooms, storage rooms, locker rooms, warehouse storage areas, janitor closets, corridors/transition areas, cafeteria/fast food dining areas, egress illumination (stairways, exit access), and other spaces ≤ 300 sf.
- Light fixture layout plans, fixture schedules, and the controls narrative must clearly identify the location of occupant-sensor-controlled light fixtures and the connected sensor/control devices.

C405.2.1
Table 9.6.1

Occupant Sensor (OS) Control Function (NOT for Open Plan Offices, Cafeteria and Fast Food Dining Areas ≥ 300 sf)

- **Automatic-Off:** Drawings must specify that occupant sensor controlled luminaires are *automatically turned off* within 15 minutes of all occupants leaving the space.
- **Manual-On or Maximum 50% Automatic-On:** Lights turned off by occupant sensor controls must be either *manually on*, or controlled to be *automatically on maximum 50%* of the lighting power in the space.
- **Manual-On ONLY:** Lights turned off by occupant sensor controls must be *only manually on* – i.e., max. 50% automatic-on is *not* allowed – in the following spaces: classrooms, conference/meeting rooms, employee break rooms, and offices < 200 sf. The sensors and controls in these spaces must *not* have an override switch that converts *from manual-on to automatic-on* functionality.
- **Full Automatic-On:** Only in the following spaces, occupant sensors with full automatic-on are allowed: open plan offices, public corridors, stairways, restrooms, primary building entrance areas and lobbies, and areas where manual-on operation would endanger the safety or security of the building occupants.
- **Manual Control to Turn Off:** Occupant-sensor-controlled luminaires must also be equipped with manual controls that allow occupants to turn lights off.

C405.2.1.1
9.4.1.1.b
9.4.1.1.c

OS Controls in Open Plan Offices, Cafeteria and Fast Food Dining Areas ≥ 300 sf

- The maximum control zone area controlled by one (1) occupant sensing device is 600 sf.
- A minimum of 80% of all lighting must be automatically turned off within 15 minutes of all occupants leaving the space.
- Daylight responsive control shall not activate general lighting controls when no occupancy is detected in these spaces.
- See page [LE-4] for required Time-switch and Light-reduction controls.

C405.2.1.1
C405.2.1.3
9.4.1.1.h

OS Controls for Egress Illumination

- Luminaires servicing Exit access and providing Means of Egress illumination must have controls that automatically reduce the lighting power by 50 % when unoccupied for more than 15 minutes.
- OS with Full Automatic-On of the lighting are allowed
- Means of Egress illumination of < 0.02 watt/sf and the Building-Code-designated Emergency lighting are exempt from this requirement.

C405.2.1.4
9.4.1.1

*For complete controls requirements on ASHRAE 90.1 per space type, refer to Section 9.4.1 and Table 9.6.1.

TIME-SWITCH & LIGHT-REDUCTION CONTROLS*

Where Required

- Spaces where “Occupant Sensor Control Function” in page [LE-3] are not provided, and
- Open Plan Offices, Cafeteria and Fast Food Dining Areas ≥ 300 sf

C405.2.2

Both Time-switch controls and Light-reduction controls must be provided. The controls’ function and locations must be clearly specified on drawings.

Time-Switch Controls (Programmed)

Time-switch controls must be designed to:

- 1) Have a minimum 7-day clock,
- 2) Allow to program 7-different day types/week,
- 3) Have an automatic holiday ‘shutoff’ feature,
- 4) Have program backup capabilities in case of power interruption, and
- 5) Include a manually-controlled override switch that, when initiated, permits the controlled lighting to remain on for a maximum of 2 hours, and that individually controls a maximum area of 5,000 sf.

C405.2.2.1

Light-Reduction Controls (Manual)

- Spaces with time-switch controls must also be provided with manual light-reduction controls that allow the occupant to reduce the connected lighting load by minimum 50%.
- Light fixture layout plans must clearly indicate the light-reduction control method, the options of which are as follows:
 - 1) Control of all lamps/luminaires
 - 2) Dual switching of alternate rows of luminaires
 - 3) Switching middle lamp luminaires independently
 - 4) Switching each lamp/luminaire

C405.2.2.2

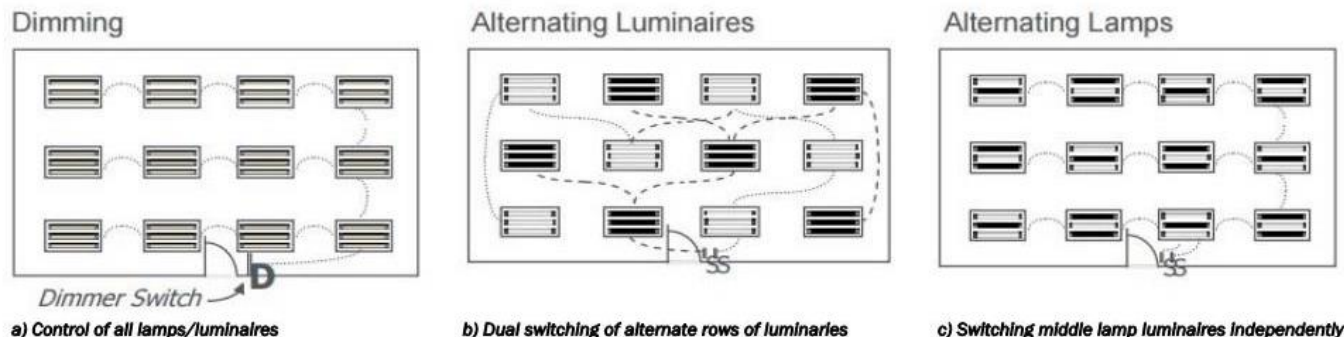

Figure LE-4.
Light-Reduction
Controls Method by

*For complete controls requirements on ASHRAE 90.1 per space type, refer to Section 9.4.1 and Table 9.6.1.

TIME-SWITCH & LIGHT-REDUCTION CONTROLS*

Where Time-Switch Controls are Exempt

If the spaces listed below are provided with *manual lighting-reduction controls*, time-switch controls are *not* required: C405.2.2

- 1) Sleeping units
- 2) Spaces where patient care is directly provided
- 3) Spaces where an automatic shutoff would endanger occupant safety or security
- 4) Lighting intended for continuous operation
- 5) Shop and laboratory classrooms

Where Light-Reduction Controls are Exempt

Light reduction controls are *not* required in *daylight zones with daylight responsive controls* complying with Section C405.2.3. C405.2.2.2

- For areas/rooms where exemptions of certain lighting controls are sought, the lighting plans and narratives must provide clear information to satisfy the exemption requirements.



Figure LE-5.a. **Patient care area Exempt from Time-Switch Controls**
Source: energy.gov/eere



Figure LE-5.b. **Daylight zone with automatic controls Exempt from Light-Reduction Controls**
Source: energycodes.gov/training

*For complete controls requirements on ASHRAE 90.1 per space type, refer to Section 9.4.1 and Table 9.6.1.

Table 9.6.1 Lighting Power Density Allowances Using the Space-by-Space Method and Minimum Control Requirements Using Either Method

<p><i>Informative Note:</i> This table is divided into two sections; this first section covers space types that can be commonly found in multiple building types. The second part of this table covers space types that are typically found in a single building type.</p>			<p>The control functions below shall be implemented in accordance with the descriptions found in the referenced paragraphs within Section 9.4.1.1. For each space type: (1) All REQs shall be implemented. (2) At least one ADD1 (when present) shall be implemented. (3) At least one ADD2 (when present) shall be implemented.</p>								
			Local Control (See Section 9.4.1.1[a])	Restricted to Manual ON (See Section 9.4.1.1[b])	Restricted to Partial Automatic ON (See Section 9.4.1.1[c])	Bilevel Lighting Control (See Section 9.4.1.1[d])	Automatic Daylight Responsive Controls for Sidelighting (See Section 9.4.1.1[e] ⁶)	Automatic Daylight Responsive Controls for Toplighting (See Section 9.4.1.1[f] ⁶)	Automatic Partial OFF (See Section 9.4.1.1[g] [Full Off complies])	Automatic Full OFF (See Section 9.4.1.1[h])	Scheduled Shutoff (See Section 9.4.1.1[i])
Common Space Types ¹	LPD Allowances, W/ft ²	RCR Threshold	a	b	c	d	e	f	g	h	i
Atrium											
<20 ft in height	0.03/ft total height	NA	REQ	ADD1	ADD1		REQ	REQ		ADD2	ADD2
≥20 ft and ≤40 ft in height	0.03/ft total height	NA	REQ	ADD1	ADD1	REQ	REQ	REQ		ADD2	ADD2
>40 ft in height	0.40 + 0.02/ft total height	NA	REQ	ADD1	ADD1	REQ	REQ	REQ		ADD2	ADD2
Audience Seating Area											
Auditorium	0.63	6	REQ	ADD1	ADD1	REQ	REQ	REQ		ADD2	ADD2
Convention center	0.65	4	REQ	ADD1	ADD1	REQ	REQ	REQ		ADD2	ADD2
Gymnasium	0.43	6	REQ	ADD1	ADD1	REQ	REQ	REQ		ADD2	ADD2
Motion picture theater	0.64	4	REQ	ADD1	ADD1	REQ	REQ	REQ		ADD2	ADD2
Penitentiary	0.28	4	REQ	ADD1	ADD1		REQ	REQ		ADD2	ADD2
Performing arts theater	2.03	8	REQ	ADD1	ADD1	REQ	REQ	REQ		ADD2	ADD2
Religious facility	1.53	4	REQ	ADD1	ADD1	REQ	REQ	REQ		ADD2	ADD2
Sports arena	0.42	4	REQ	ADD1	ADD1		REQ	REQ		ADD2	ADD2
All other audience seating areas	0.40	4	REQ	ADD1	ADD1		REQ	REQ		ADD2	ADD2
Banking Activity Area	0.79	6	REQ	ADD1	ADD1	REQ	REQ	REQ		ADD2	ADD2
Breakroom (See Lounge/Breakroom)											
Classroom/Lecture Hall/Training Room^{9,10}											
Penitentiary	1.06	4	REQ	ADD1	ADD1	REQ	REQ	REQ		REQ	
All other classrooms/lecture halls/training rooms	0.74	4	REQ	REQ		REQ	REQ	REQ		REQ	
Conference/Meeting/Multipurpose Room ^{9,10}	0.93	6	REQ	REQ		REQ	REQ	REQ		REQ	
Confinement Cells	0.52	6	REQ	ADD1	ADD1	REQ	REQ	REQ		ADD2	ADD2
Copy/Print Room	0.50	6	REQ	ADD1	ADD1	REQ	REQ	REQ		REQ	

From: [REDACTED]
Sent: [REDACTED]
To: 'Energy Code (Buildings)'
Subject: 2020 NYCECC

I have a question about lighting controls in open offices. Based on the 2020 NYCECC it does not seem like manual controls are required in Chapter C4.

In 2016 version, Open offices were required to meet C405.2.1 (occupant sensor controls.) They then needed to meet the requirements of C405.2.1.1 of auto off, manual of 50%, and have a manual control.

In 2020 version, open offices, cafeteria dining areas and fast food dining areas need to meet section C405.2.1.3, but does not say they need to meet items 1-3 under C405.2.1.1. "Occupant sensor controls for all other spaces specified in Section C405.2.1 shall comply with the following:". There is nothing about manual controls in C405.2.1.3

Is this interpretation correct?

Thanks.

C405.2.1.1 Occupant sensor control function. Occupant sensor controls in warehouses shall comply with Section C405.2.1.2. **Occupant sensor controls in open plan office areas, cafeteria dining areas, and fast food dining areas, 300 square feet (28 m²) or greater in area, shall comply with Section C405.2.1.3.** Occupant sensor controls for all other spaces specified in Section C405.2.1 shall comply with the following:

Open plan office areas
< 300 sf

1. They shall automatically turn off lights within 15 minutes after all occupants have left the space.
2. They shall be manual-on or controlled to automatically turn on the lighting to not more than 50-percent power.

Exceptions:

1. Full automatic-on controls shall be permitted to control lighting in public corridors, stairways, restrooms, primary building entrance areas and lobbies, and areas where manual-on operation would endanger the safety or security of the room or building occupants.
2. Manual-on controls shall be required for classrooms (not including shop classrooms, laboratory classrooms, and preschool classrooms), conference/meeting rooms, employee lunch and break rooms, and offices smaller than 200 square feet (18.5 m²) in area. Such sensors and controls shall not have an override switch that converts from manual-on to automatic-on functionality, and may have a grace period of up to 30 seconds to turn on the lighting automatically after the sensor has turned off the lighting if occupancy is detected.
3. They shall incorporate **a manual control** to allow occupants to turn off lights.

Exception: Remote location of this local *control device* or devices shall be permitted for reasons of safety or security when each remote *control device* has an indicator pilot light as part of or next to the *control device* and the light is clearly *labeled* to identify the controlled lighting.

C405.2.1.3 Occupant sensor control function in open plan office areas, cafeteria dining areas, and fast food dining areas. Occupant sensor controls in open plan office spaces, cafeteria dining areas, and fast food dining areas less than 300 square feet (28 m²) in area shall comply with Section C405.2.1.1. Occupant sensor controls in all other open plan office spaces, cafeteria dining spaces, and fast food dining spaces shall comply with all of the following:

1. The controls shall be configured so that general lighting can be controlled separately in control zones with floor areas not greater than 600 square feet (55 m²) within the open plan office space or dining space.
2. The controls shall automatically turn off general lighting in all control zones within 15 minutes after all occupants have left the open plan office space or dining space.
3. The controls shall be configured so that general lighting power in each control zone is reduced by not less than 80 percent of the full zone general lighting power in a reasonably uniform illumination pattern within 15 minutes of all occupants leaving that control zone. Control functions that switch control zone lights completely off when the zone is vacant meet this requirement.
4. The controls shall be configured such that any daylight responsive control will activate open plan office space general lighting or control zone general lighting only when occupancy for the same area is detected.

Open plan office areas
≥ 300 sf

C405.2.2 Time-switch controls. Each area of the building that is not provided with occupant sensor controls complying with Section C405.2.1.1 shall be provided with time-switch controls complying with Section C405.2.2.1.

Open plan office areas
≥ 300 sf

C405.2.2.1 Time-switch control function. Each space provided with time-switch controls shall be provided with a manual control for light reduction in accordance with Section C405.2.2.2. Time-switch controls shall include an override switching device that complies with the following:

1. Have a minimum 7-day clock.
2. Be capable of being set for seven different day types per week.
3. Incorporate an automatic holiday “shutoff” feature, which turns off all controlled lighting loads for not fewer than 24 hours and then resumes normally scheduled operations.
4. Have program backup capabilities, which prevent the loss of program and time settings for not fewer than 10 hours, if power is interrupted.
5. Include an override switch that complies with the following:
 - 5.1. The override switch shall be a manual control.
 - 5.2. The override switch, when initiated, shall permit the controlled lighting to remain on for not more than 2 hours.
 - 5.3. Any individual override switch shall control the lighting for an area not larger than 5,000 square feet (465 m²).

<p><i>Informative Note:</i> This table is divided into two sections; this first section covers <i>space</i> types that can be commonly found in multiple <i>building</i> types. The second part of this table covers <i>space</i> types that are typically found in a single <i>building</i> type.</p>			<p>The <i>control</i> functions below shall be implemented in accordance with the descriptions found in the referenced paragraphs within Section 9.4.1.1. For each <i>space</i> type:</p> <p>(1) All REQs shall be implemented. (2) At least one ADD1 (when present) shall be implemented. (3) At least one ADD2 (when present) shall be implemented.</p>								
			Local Control (See Section 9.4.1.1[a])	Restricted to Manual ON (See Section 9.4.1.1[b])	Restricted to Partial Automatic ON (See Section 9.4.1.1[c])	Bilevel Lighting Control (See Section 9.4.1.1[d])	Automatic Daylight Responsive Controls for Sidelighting (See Section 9.4.1.1[e] ⁶)	Automatic Daylight Responsive Controls for Toplighting (See Section 9.4.1.1[f] ⁶)	Automatic Partial OFF (See Section 9.4.1.1[g] [Full Off complies])	Automatic Full OFF (See Section 9.4.1.1[h])	Scheduled Shutoff (See Section 9.4.1.1[i])
Common Space Types ¹	LPD Allowances, W/ft ²	RCR Threshold	a	b	c	d	e	f	g	h	i
Lobby											
Facility for the visually impaired (and not used primarily by the staff) ³	2.03	4	REQ				REQ	REQ	REQ	ADD2	ADD2
Elevator	0.52	6	REQ				REQ	REQ		ADD2	ADD2
Hotel	0.68	4	REQ				REQ	REQ		ADD2	ADD2
Motion picture theater	0.38	4	REQ				REQ	REQ		ADD2	ADD2
Performing arts theater	0.82	6	REQ				REQ	REQ	REQ	ADD2	ADD2
All other lobbies	0.90	4	REQ				REQ	REQ	REQ	ADD2	ADD2
Locker Room	0.45	6	REQ	ADD1	ADD1	REQ	REQ	REQ		REQ	
Lounge/Breakroom^{9, 10}											
Healthcare facility	0.53	6	REQ	REQ		REQ	REQ	REQ		REQ	
All other lounges/breakrooms	0.44	4	REQ	REQ		REQ	REQ	REQ		REQ	
Office											
Enclosed and ≤ 250 ft ² (^{9, 10})	0.85	8	REQ	REQ		REQ	REQ	REQ		REQ	
Enclosed and > 250 ft ²	0.85	8	REQ	ADD1	ADD1	REQ	REQ	REQ		ADD2	ADD2
Open plan < 300 ft ²	0.78	4	REQ	ADD1	ADD1	REQ	REQ	REQ		REQ	
Open plan ≥ 300 ft ² (¹¹)	0.78	4	REQ	ADD1	ADD1	REQ	REQ	REQ	REQ		

Open plan < 300 sf: requirements of Appendix CA – comparable to provisions in C405.2.1.1

Open plan ≥ 300 sf: requirements of Appendix CA – comparable to provisions in C405.2.1.3 and C405.2.2

**ELECTRIC VEHICLE
SERVICE READY**

R404.3 Electrical vehicle service equipment capable (Mandatory). One or two-family dwellings and townhouses with parking area provided on the building site shall provide a 208/240V 40-amp outlet for each dwelling unit or panel capacity and conduit for the future installation of such an outlet. Outlet or conduit termination shall be adjacent to the parking area. For residential occupancies where there is a common parking area, provide either:

1. Panel capacity and conduit for the future installation of 208/240V 40-amp outlets for 5 percent of the total parking spaces, but not less than one outlet, or
2. 208/240V 40-amp outlets for 5 percent of the total parking spaces, but not less than one outlet.

ELECTRICAL VEHICLE SERVICE READY

- **This Requirement Applies to**

- One or Two-family dwellings with Parking area
- Low-rise Multi-family buildings with Parking area
- Townhouses with Parking area

- **For Each Dwelling Unit, provide:**

- 208/240V 40-amp outlet, or
- Panel capacity and conduit for the future installation of such an outlet adjacent to the parking area.

- **For Residential occupancies with Common Parking Area, provide:**

- Panel capacity and conduit for the future installation of 208/240V 40-amp outlets for 5 percent of the total parking spaces, but not less than one outlet, or
- 208/240V 40-amp outlets for 5 percent of the total parking spaces, but not less than one outlet.



Figure OR-7.
Electrical Outlet Ready for Electrical Vehicle Service
 Source: basc.pnnl.gov/images

“A new detached 1-car garage built as accessory to a new Group R3 single-family detached residence...

...The garage has no lighting fixtures, no electrical outlets, no wiring for future lighting, heating, or motorized overhead door, and no electric panel is installed in the garage...

Is compliance with the R404.3 required?”

YES, the requirement applies.

- **“One or two-family dwellings and townhouses with parking area provided on the building site shall provide a 208/240V 40-amp outlet for each dwelling unit or...”**
- **R404.3 applies regardless of whether electrical wiring for the parking space is intended.**
- **R404.3 applies regardless of whether the new garage is exempt from the envelope, lighting, and/or HVAC portions of the NYCECC.**

“An existing 2-story, 1-family residence is enlarged (via alteration and addition) to a 3-story, 2-family dwelling, but this job application is not required to meet New Building requirement.

The existing detached 1-car garage will remain as is (not part of the alteration), yet an additional open parking space is planned on site.

a. Is compliance with R404.3 required for the existing garage?

b. Is compliance with R404.3 required for the open parking space?”

YES, compliance with R404.3 is required for both the existing garage and the new open parking space.

Additional electrical service is called for in this Alteration (enlargement) job application, i.e., amperage to the existing electrical panel is increased to service the two-family residence. This triggers compliance requirement for the existing detached garage for one-family. The new open parking space also is required to be EV service capable for the other family in the two-family residence.

BUILDINGS BULLETINS

ADDITIONAL RESOURCES ONLINE



BUILDINGS 2020-007 BULLETIN TECHNICAL

ISSUANCE DATE
May 12, 2020

SUPERSEDES
Buildings Bulletin 2017-006



ISSUER: Gus Sirakis, P.E. *G. Sirakis*
First Deputy Commissioner

PURPOSE: This document clarifies conditions under which an addition, alteration, or repair to a building envelope may not be required to comply with the 2020 New York City Energy Conservation Code (NYCECC), pursuant to section NYCECC Chapters R5, C5, or Appendix CA (amendments to ASHRAE 90.1-2016).

SUBJECT(S): Additions, building envelope; Alterations, building envelope; Repairs, building envelope; Energy Code, existing building thermal envelope; Energy Code, existing roof assembly; Energy Code, existing exterior wall; Energy Code, existing curtain wall; Energy Code, existing frame wall; Energy Code, existing masonry wall; Energy Code, existing basement wall; Energy Code, existing slab-on-grade; Energy Code, existing doors; Energy Code, existing windows; Energy Code, existing skylights; New York City Energy Conservation Code; Energy Code.

In accordance with Section R402, Chapter R5, Section C402, and Chapter C5 of the NYCECC, and Section 5 of ASHRAE 90.1, additions, alterations, and/or repairs made to a building envelope shall comply with this bulletin, provided that the energy use of the building is not increased.

I. DEFINITIONS

Terms used in this bulletin shall have the same meanings as set forth in Chapters R2 and C2 of the NYCECC, 1 RCNY 5000-01 and, for the purposes of this bulletin only, as follows:

- A. Roof plane.** A single plane of a roof assembly, whether at the top of a building or a roof setback, limited by a ridge, edge, wall, parapet or rail. Such roof plane is part of the envelope system and encloses conditioned space.
- B. Wall plane.** A single plane of an exterior wall assembly, from exterior corner to exterior corner, and foundation to roof plate or deck, inclusive of defining structural elements.

II. EXCEPTIONS

Exceptions to the requirement to comply with the provisions of the NYCECC related to building envelopes.

Refer to Exceptions 1 through 6 under Section R503.1.1, Items 1, 2 and 4 under Section R504.2, Exceptions 1 through 7 under Section C503.1, and Items 1 through 4 under Section C504.2 of the NYCECC for relief for certain alterations and/or repairs to the existing building thermal envelope from the requirement to comply with the NYCECC provisions for new buildings, provided that the energy use of the building is not increased.



BUILDINGS 2020-008 BULLETIN TECHNICAL

ISSUANCE DATE
May 12, 2020

SUPERSEDES
Buildings Bulletin 2017-004



ISSUER: Gus Sirakis, P.E. *G. Sirakis*
First Deputy Commissioner

PURPOSE: This document clarifies conditions under which an addition, alteration, or repair to a lighting or electrical power system or control equipment may not be required to comply with the New York City Energy Conservation Code (NYCECC), pursuant to NYCECC Chapter R5, Chapter C5, and Appendix CA (amendments to ASHRAE 90.1-2016).

SUBJECT(S): Additions, lighting systems; Alterations, lighting systems; Repairs, lighting systems; Replacement, lighting systems; Lighting systems, luminaires; Lighting systems, lighting fixtures; Lighting systems, lighting fixtures, lamps; Lighting systems, lighting fixtures, ballasts; Lighting systems, lighting power density; Interior lighting; Exterior lighting; Lighting systems, commissioning; Electrical, electrical or control equipment; Electrical, energy use; New York City Energy Conservation Code; Energy Code

In accordance with NYCECC Chapter R5, Chapter C5, R404, C405, C408, and ASHRAE 90.1 sections 8, 9 and 10, additions, alterations, and/or repairs to lighting and/or power systems and equipment shall be as follows, provided that energy use of the building is not increased:

I. DEFINITIONS

In accordance with NYCECC Chapter R5, Chapter C5, R404, C405, C408, and ASHRAE 90.1 sections 8, 9 and 10, additions, alterations, and/or repairs to lighting and/or power systems and equipment shall be as follows, provided that energy use of the building is not increased:

A. High-efficacy. Lighting fixtures having lamps with an efficacy of at least 65 lumens per watt, or having a total luminaire efficacy of at least 45 lumens per watt.

II. INTERIOR LIGHTING SYSTEMS

Lighting fixtures having lamps with an efficacy of at least 65 lumens per watt, or having a total luminaire efficacy of at least 45 lumens per watt:

A. Luminaires. When following the NYCECC Chapter C5, and 10 percent or more of the luminaires within a space are being replaced, the alteration or repair in each case shall comply with the lighting provisions of the NYCECC as applicable. When following the NYCECC Chapter R5, and 20 percent or more of the luminaires within a space are being replaced, the alteration or repair in each case shall comply with the lighting provisions of the NYCECC as applicable. When following ASHRAE 90.1, and more than 10 percent of the connected lighting load within a space or area is being replaced, the alteration or repair in each case shall comply with the lighting provisions of ASHRAE 90.1 as applicable.



BUILDINGS 2020-009 BULLETIN TECHNICAL

ISSUANCE DATE
May 12, 2020

SUPERSEDES
Buildings Bulletin 2017-005



ISSUER: Gus Sirakis, P.E. *Chirali*
First Deputy Commissioner

PURPOSE: This document clarifies conditions under which an addition, alteration, or repair to HVAC and/or service water heating systems may not be required to comply with the 2020 New York City Energy Conservation Code (NYCECC), pursuant to NYCECC Chapters R5, C5, and Appendix CA (amendments to 90.1-2016).

SUBJECT(S): Additions, mechanical system; Alterations, mechanical system; Repairs, mechanical system; Replacement, mechanical system; Additions, service water heating system; Alterations, service water heating system; Repairs, service water heating system; Replacement, service water heating system; Additions, HVAC; Alterations, HVAC; Repairs, HVAC; Replacement, HVAC; Commissioning, HVAC; Insulation, HVAC; New York City Energy Conservation Code; Energy Code

In accordance with NYCECC Chapter R5, Chapter C5, sections R403, C403, C404, C408 and ASHRAE 90.1 sections 6, 7 and 10, additions to mechanical and/or service water heating systems shall comply with such sections for new construction. Alterations and/or repairs to mechanical, service water heating systems, and/or insulation shall be as follows, provided that energy use of the building is not increased:

I. EQUIPMENT

Replacement of head-end or terminal equipment, ductwork and/or piping regulated by sections NYCECC R403, C403, C404 and/or ASHRAE 90.1 sections 6, 7 and/or 10 shall be required to comply with the NYCECC, except where there is insufficient space or access to meet ductwork and/or piping requirements. Replacement of equipment parts, such as tubes within a boiler, is not regulated by the NYCECC. Any deviation from the Energy Code due to existing building conditions must be indicated in the energy analysis of the construction documents.

Exception for Terminal Unit

Where replacement equipment is a terminal unit of a non-compliant system and there is no compliant equipment that would fulfill the function of the equipment, the replacement equipment need not comply, provided the energy use of the building is not increased.

II. SYSTEMS INCLUDING BUT NOT LIMITED TO CONTROL SYSTEMS AND DEVICES

Alterations and/or repairs to systems, including heating systems, cooling systems, ventilation systems and/or service water heating systems, shall be required to comply with the NYCECC as follows:

A. Whole system replacement. Replacement of an entire building system, or of a whole system serving a portion of the building, shall comply with the provisions of the NYCECC.

USEFUL LINKS

Energy Conservation Code

<https://www1.nyc.gov/site/buildings/codes/energy-conservation-code.page>

2020 New York City Energy Conservation Code

How-to Guide: Supporting Documentation

https://www1.nyc.gov/assets/buildings/pdf/h2g_all_2020_nycecc.pdf

Buildings Bulletins

<https://www1.nyc.gov/site/buildings/codes/building-bulletins.page>

Energy Code Technical Questions?

email to: EnergyCode@buildings.nyc.gov

QUESTIONS ???



This concludes the
American Institute of Architects
Continuing Education Systems Course.

Department Contact for AIA:
Melanie Guzman
Melaguzman@buildings.nyc.gov, 212-393-2163

© 2021 New York City Department of Buildings