



# **223 Ford**

## **Compressor/Alternator Bracket Kit**

### **(131138)**

**Fits:**  
**1961-64 Ford F-100 and Others**

**May Be Used With or Without**  
**Power Steering Bracket Add-On Kit 131140**

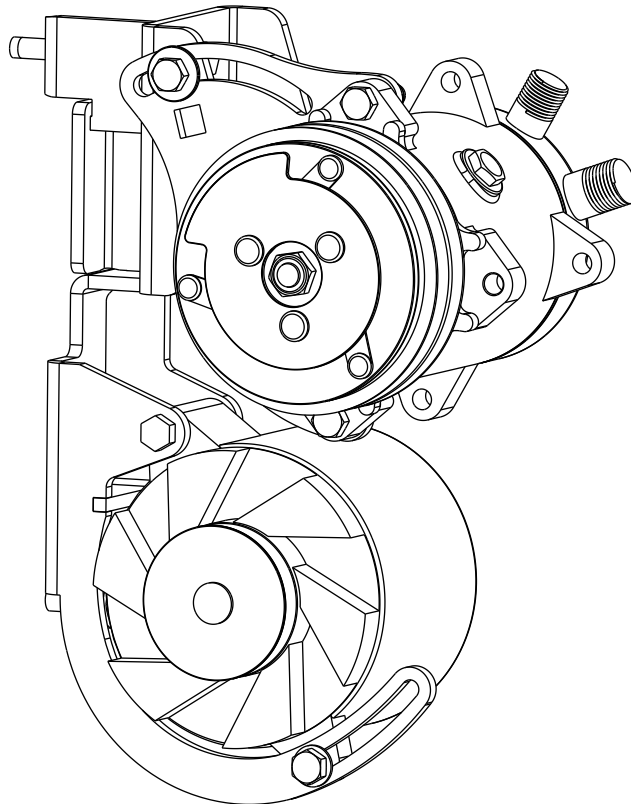

**18865 Goll St. San Antonio, TX 78266**  
**Phone: 800-862-6658**  
**Sales: [sales@vintageair.com](mailto:sales@vintageair.com)**  
**Tech Support: [tech@vintageair.com](mailto:tech@vintageair.com)**  
**[www.vintageair.com](http://www.vintageair.com)**



www.vintageair.com

# Table of Contents

Cover..... 1

Table of Contents..... 2

Additional Information..... 3

Packing List/Parts Disclaimer..... 4

Engine Compartment Disassembly & Add-On Pulley Installation..... 5

Compressor/Alternator Bracket Assembly Installation (Without Power Steering)..... 6

Compressor/Alternator Bracket Assembly Installation (With Power Steering)..... 7

Alternator Installation..... 8

Compressor Installation..... 9

Power Steering Hose Fitting Installation (with Power Steering Add-On Kit).....10

Power Steering Pulley & Pump Installation (with Power Steering Add-On Kit)..... 11

Belt Routing, Tightening Belts, Compressor Warnings..... 12

Packing List..... 13



www.vintageair.com

## Additional Parts & Accessories

Because of the variety of available applications, Vintage Air does not make specific recommendations for power steering fittings, hoses or adapters for 1961-64 Ford F-100s. However, listed below are fittings and hoses available through Vintage Air that may be suitable for your application.

**NOTE: AN and JIC fittings are interchangeable in most aftermarket automotive hydraulic applications. When adapting from an inverted flare fitting to an AN or JIC fitting, be sure to use an adapter suited for this purpose and NOT an NPT to AN or JIC adapter.**

### Power Steering Accessories

#### **DSE Hose Kit**

**852008** Early GM (1965-81)

**852009** Mustang II

**852012** Ford Fox Body (1979-2004)  
(Fox Body rack & pinion has external hardlines)



#### **DSE Steering Hardline**

**852000** TiteFit Hardline



**NOTE: Pump not included with hardline (Shown for reference only).**

#### **Flow Control Valve**

**852001** For Mustang II Rack & Pinion  
(Reduces flow to 2.0 GPM)



#### **Banjo Fitting**

**852010** For DSE Hose Kit  
(High-pressure outlet)

#### **Banjo Fitting**

**852011** For -6AN Fitting



## Additional Info: Please Read Before Beginning

### **Alternator Requirements:**

This bracket kit is designed for use with GM 10SI and 12SI alternators only. The following 12SI alternators are available from Vintage Air:

- 09100-VUA**—100-Amp GM Standard Finish
- 09100-VUQ**—100-Amp GM All Chrome Finish
- 09140-VUA**—140-Amp GM Standard Finish
- 09140-VUQ**—140-Amp GM All Chrome Finish



www.vintageair.com

# Packing List: Bracket Kit (131138)

No.	Qty.	Part No.	Description
1.	1	730010	Add-on Pulley, Black Hardcoat
2.	1	131136	Bracket Assembly, Compressor/Alternator
3.	1	146006-SCR	Bracket, Compressor Adjustment
4.	1	191046	Hardware Kit

**\*\* Before beginning installation, open all packages and check contents of shipment. Please report any shortages directly to Vintage Air within 15 days. After 15 days, Vintage Air will not be responsible for missing or damaged items.**

1

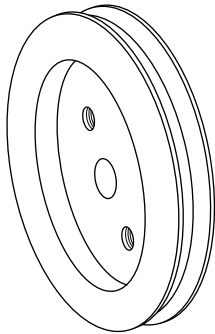

2

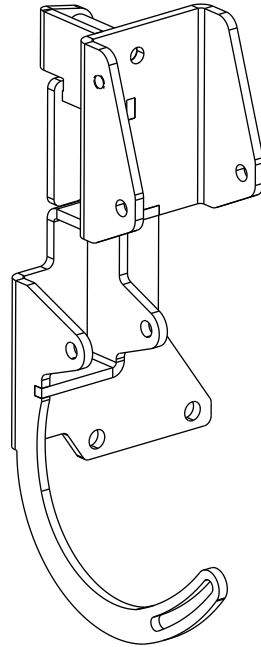

3

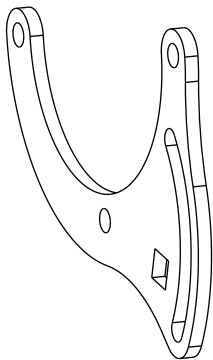

4

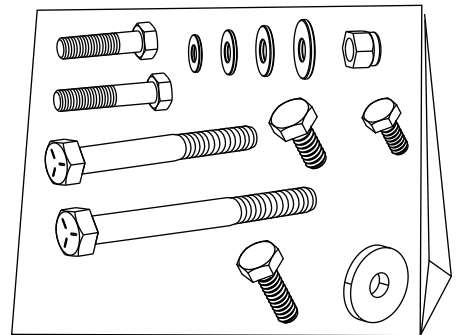

**NOTE: Images may not depict actual parts and quantities. Refer to packing list for actual parts and quantities.**

# Engine Compartment Disassembly & Add-On Pulley Installation

1. Disconnect the battery.
2. Remove the alternator or generator, power steering pump (if equipped), and brackets (See Photo 1, below).
3. Remove the center bolt and washer from the crankshaft pulley (retain, but discard washer) (See Photo 2, below).
4. Using (2) 3/8-16 x 1 1/2" hex bolts and (2) 3/8" washers, install the supplied add-on pulley in front of the crankshaft pulley (See Photo 3, below). Do not tighten the bolts at this time. **NOTE: Once the add-on pulley is installed, clearance between the motor mount and pulley will be tight. Because of this, Vintage Air recommends slipping the drive belts over the crankshaft pulley prior to add-on pulley installation.**
5. Reinstall the crankshaft pulley center bolt with a 9/16" flat washer (See Photo 3, below). Torque to 70-90 lb ft. Tighten the (2) 3/8" bolts installed in Step 2, above.
6. Remove the top bolt from the driver side front motor mount as shown in Photo 4, below. **NOTE: With the motor mount bolt removed, it is possible for the engine to shift out of alignment with the bolt hole on the mount. To prevent this, Vintage Air recommends safely supporting the engine prior to motor mount bolt removal.**

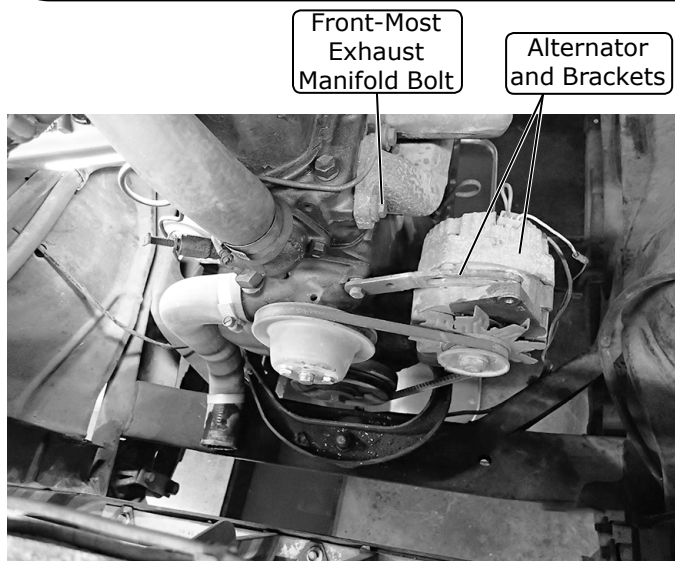

Photo 1

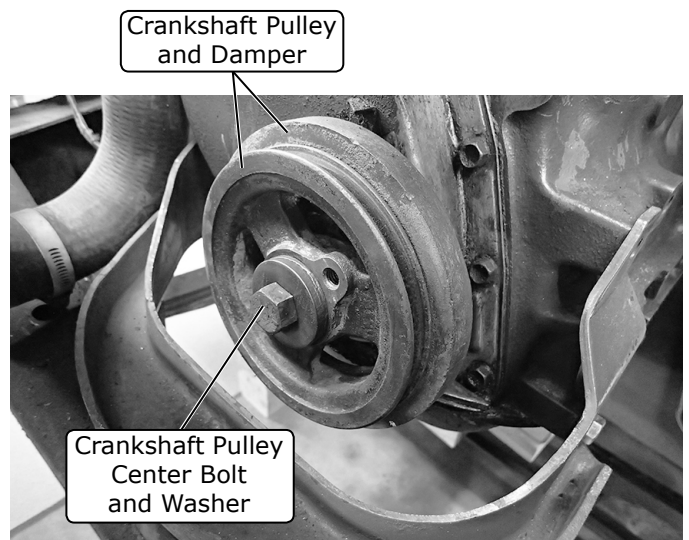

Photo 2

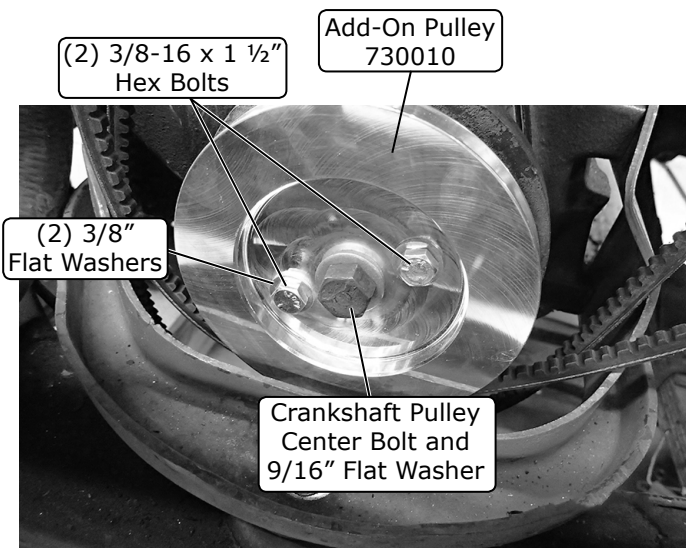

Photo 3

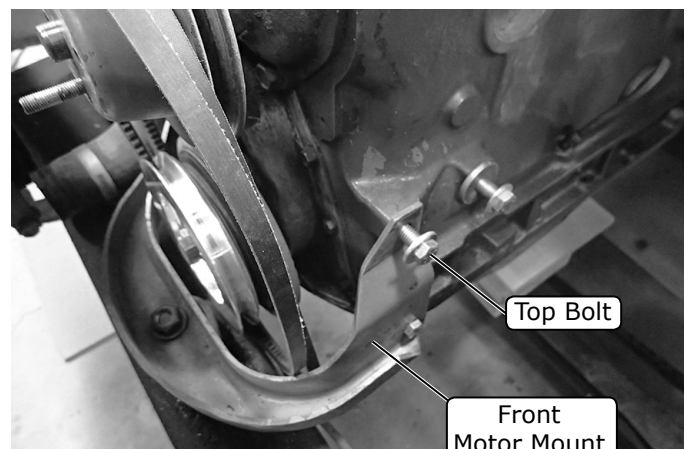
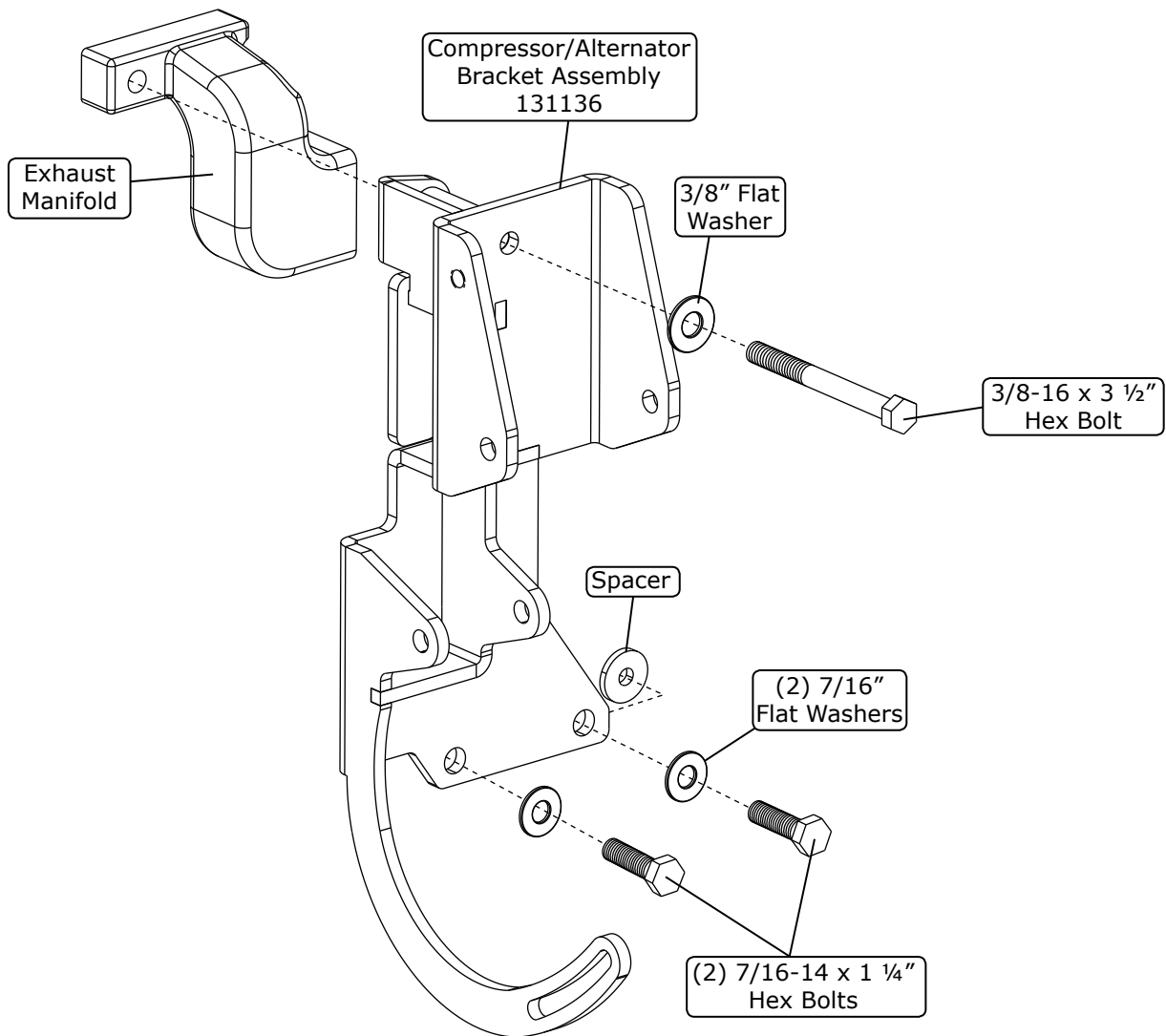

Photo 4

**NOTE:** Before tightening bolts, assemble all brackets loosely to engine. This will ensure proper alignment of all brackets.

## Compressor/Alternator Bracket Assembly Installation (without Power Steering)

1. Remove the front-most bolt from the exhaust manifold (See Photo 1, Page 5). **NOTE: Vintage Air recommends applying penetrating oil to the exhaust manifold bolt before removal.**
2. Insert a 3/8-16 x 3 1/2" hex bolt with a 3/8" flat washer through the top mounting hole of the compressor/alternator bracket assembly and into the exhaust manifold as shown in Figure 1, below. Torque to 23 lb ft.
3. Insert a 7/16-14 x 1 1/4" hex bolt with a 7/16" flat washer into the bottom front hole of the compressor/alternator bracket assembly, through the motor mount bracket, and into the engine boss (See Figure 1, below). Torque to 37 lb ft.
4. Locate the spacer supplied with the hardware kit. Insert a 7/16-14 x 1 1/4" hex bolt with a 7/16" flat washer into the bottom rear hole of the compressor/alternator bracket assembly, through the spacer, and into the engine boss (See Figure 1, below). Torque to 37 lb ft.

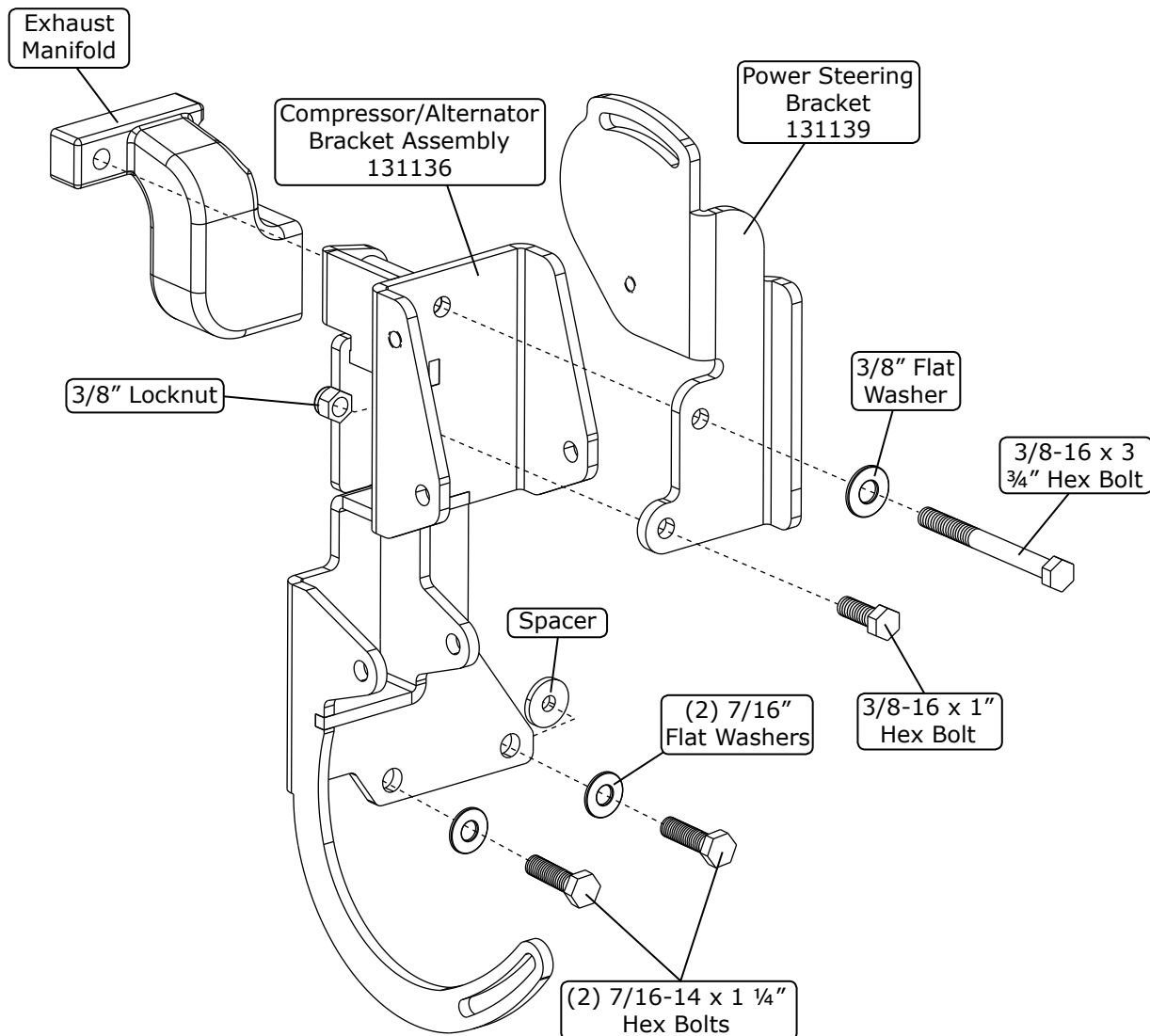

**Figure 1**

**NOTE: Before tightening bolts, assemble all brackets loosely to engine. This will ensure proper alignment of all brackets.**

## Compressor/Alternator Bracket Assembly Installation (with Power Steering)

1. Remove the front-most bolt from the exhaust manifold (See Photo 1, Page 4). **NOTE: Vintage Air recommends applying penetrating oil to the exhaust manifold bolt before removal.**
2. Insert a 3/8-16 x 3 3/4" hex bolt with a 3/8" flat washer into the top hole of the power steering bracket, through the compressor/alternator bracket assembly, and into the exhaust manifold bolt hole as shown in Figure 2, below. Torque to 23 lb ft.
3. Insert a 3/8-16 x 1" hex bolt into the bottom hole of the power steering bracket, through the compressor/alternator bracket assembly, and into a 3/8" locknut as shown in Figure 2, below. Torque to 23 lb ft.
4. Insert a 7/16-14 x 1 1/4" hex bolt with a 7/16" flat washer into the bottom front hole of the compressor/alternator bracket assembly, through the motor mount bracket, and into the engine boss (See Figure 2, below). Torque to 37 lb ft.
5. Locate the spacer supplied with the hardware kit. Insert a 7/16-14 x 1 1/4" hex bolt with a 7/16" flat washer into the bottom rear hole of the compressor/alternator bracket assembly, through the spacer, and into the engine boss (See Figure 2, below). Torque to 37 lb ft.



**Figure 2**

## Alternator Installation

1. Install the alternator onto the compressor/alternator bracket assembly using a 3/8-16 x 3" hex bolt, a 3/8" locknut, a 5/16-18 x 3/4" hex bolt, and a 5/16" flat washer as shown in Figure 3, below.
2. Reconnect the alternator wiring.

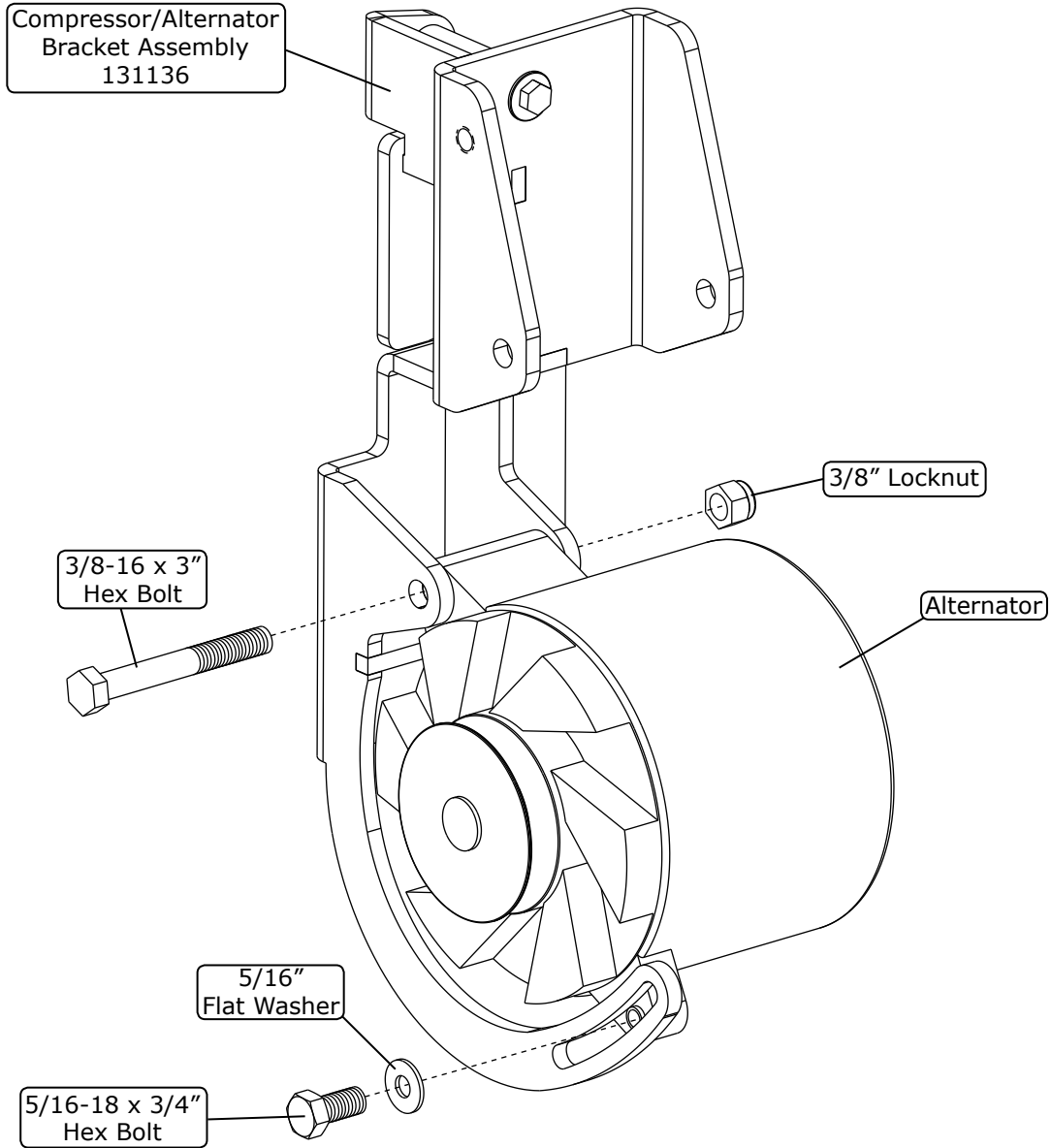
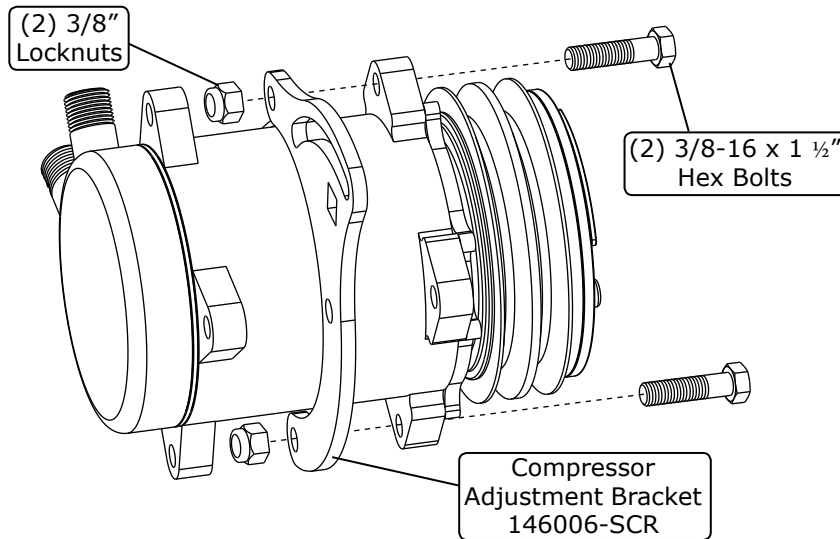

**Figure 3**



## Compressor Installation

1. On a workbench, install the compressor adjustment bracket onto the compressor using (2) 3/8-16 x 1 1/2" bolts and (2) 3/8" locknuts as shown in Figure 4, below. Torque bolts to 23 lb ft.
2. Install the compressor assembly onto the compressor/alternator bracket assembly using a 3/8-16 x 1 3/4" hex bolt, a 3/8-16 x 1 1/2" hex bolt, (2) 3/8" locknuts, a 3/8-16 x 3/4" hex bolt, and a 3/8" flat washer as shown in Figure 5, below. Torque bolts to 23 lb ft.



**Figure 4**

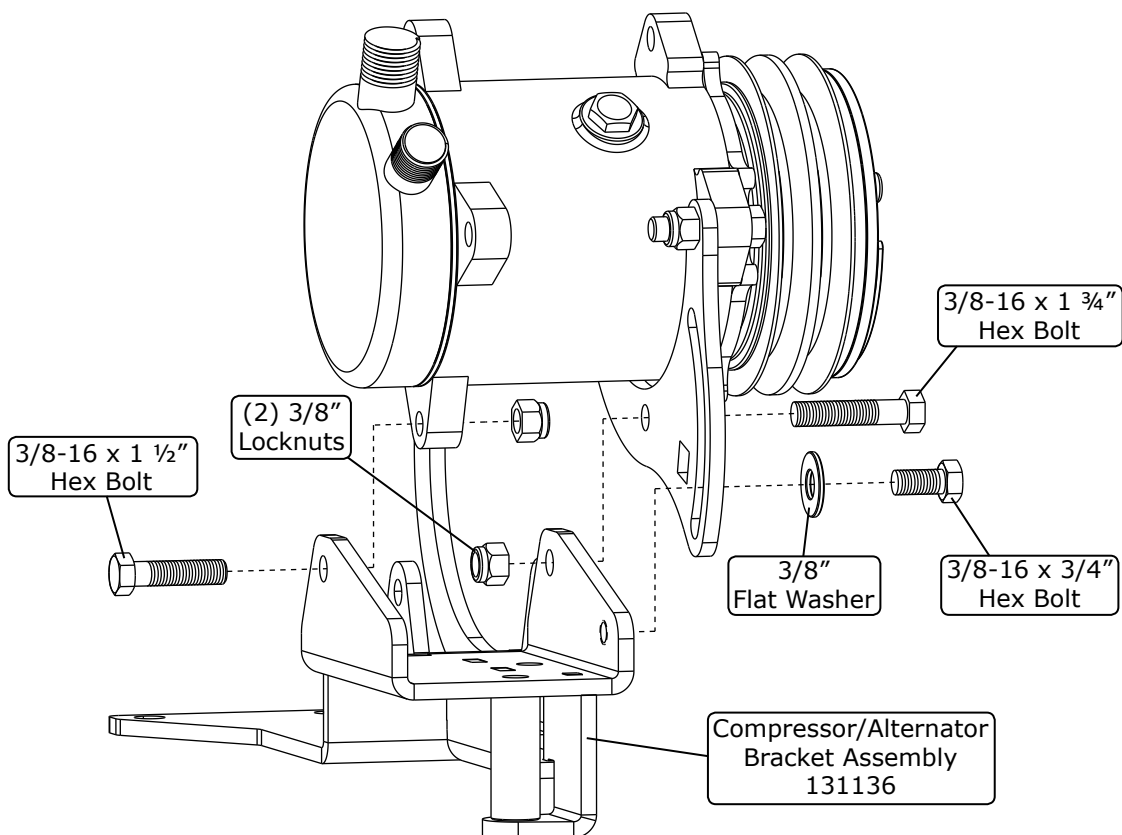
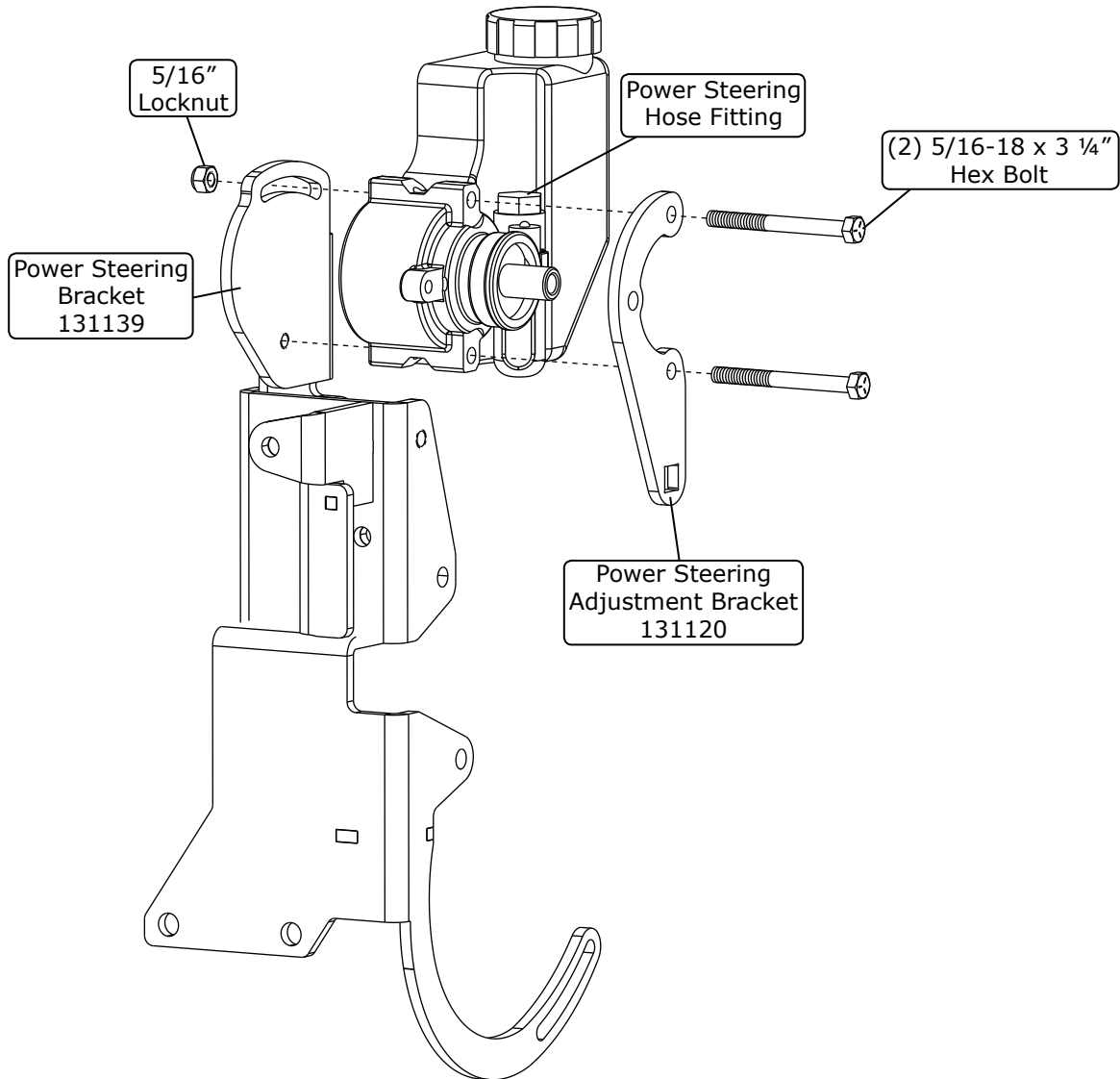

**Figure 5**

# Power Steering Hose Fitting Installation (with Power Steering Add-On Kit)

**NOTES:**

- A high-pressure fitting (not included with this kit) is required for hose connection. Several options are available through Vintage Air (See Additional Accessories on Page 3 of this instruction booklet).
  - TC power steering pump flow rate is 3.0 to 3.4 gallons per minute at 1500 RPM. For rack-and-pinion systems that require a lower flow rate, a flow control valve (Vintage Air Part # 852001) may be purchased to reduce the flow to 2.0 GPM (See Additional Accessories on Page 3). Consult with the rack manufacturer to determine flow rate requirements.
1. Install the hose fitting onto the power steering pump (See Figure 6, below). In order to properly tighten the fitting, Vintage Air recommends temporarily mounting the pump onto the bracket (See Figure 6, below).  
**NOTE: Do not apply any pressure or torque to the power steering pump reservoir, as this may damage the reservoir.**
  2. After installing the hose fitting, remove the pump from the bracket.



**Figure 6**

# Power Steering Pulley & Pump Installation (with Power Steering Add-On Kit)

**WARNING:** The pulley must be installed with the proper tool (K-D Tool #2897 or equivalent). Do not attempt to hammer or press the pulley onto the power steering pump shaft! Failure to use the proper tool will destroy the pump.

**NOTE:** Some Type-II GM power steering pumps (non-Vintage Air pumps only) have threaded mounting bases. These must be drilled out to allow the mounting bolts to pass through the holes and thread into the bracket (See Figure 7, below).

1. On a workbench, using a power steering pump pulley installer, install the pulley onto the power steering pump (See Figure 8, below, and video demonstration at [bit.ly/vapulley](http://bit.ly/vapulley)). Ensure that the pulley is installed to the proper specifications as shown in Figure 8, below.
2. Install the power steering pump and adjustment bracket onto the power steering bracket using (2) 5/16-18 x 3 1/4" hex bolts and a 5/16" locknut as shown in Figure 9, below. Torque bolts to 13 lb ft.
3. Install the supply and return power steering hoses.

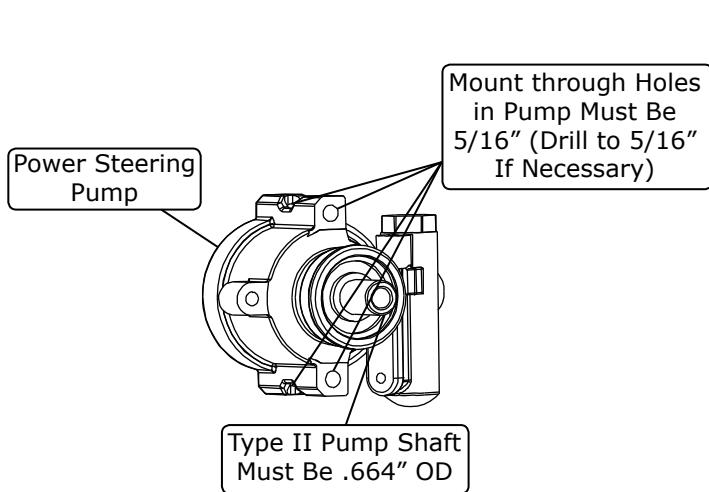

**Figure 7**

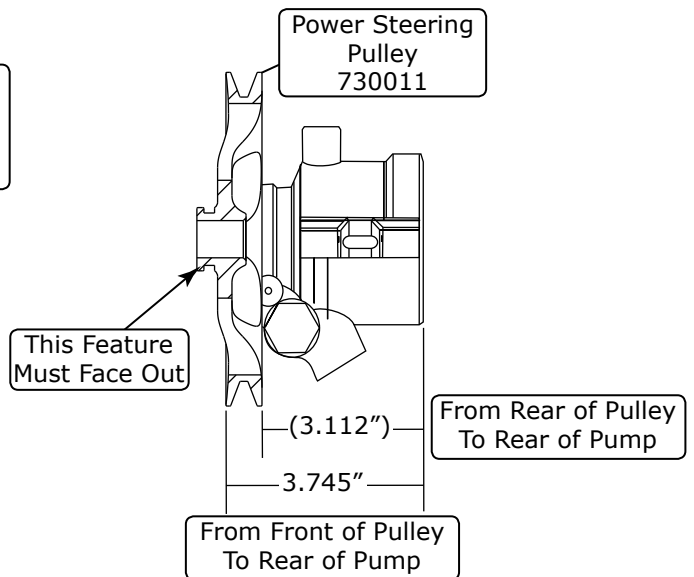

**Figure 8**

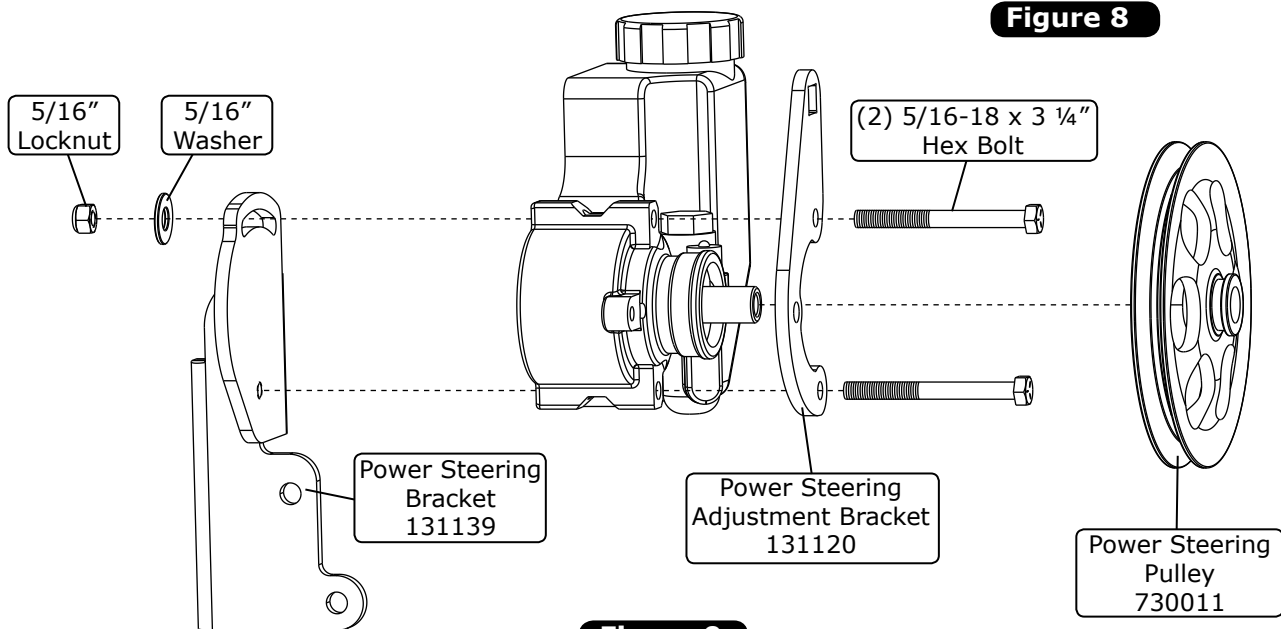
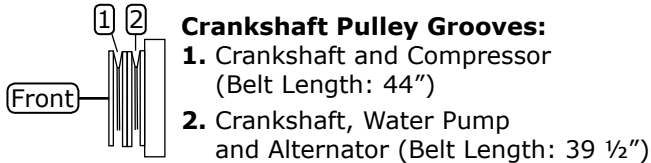
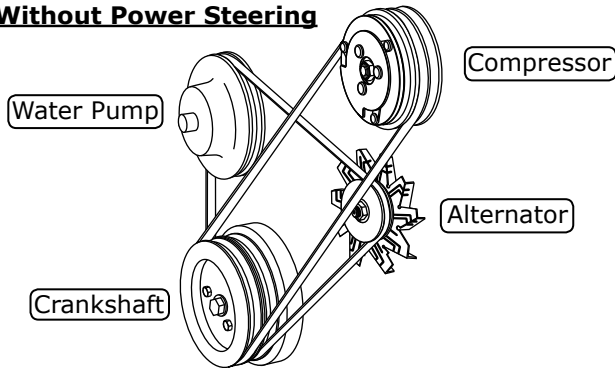

**Figure 9**

## Belt Routing

1. Route belts as shown below. Vintage Air recommends using only Dayco, Gates or Goodyear brand reinforced V-belts with this bracket kit. **NOTE: Place all belts on pulleys before tensioning.**

### Without Power Steering



### With Power Steering

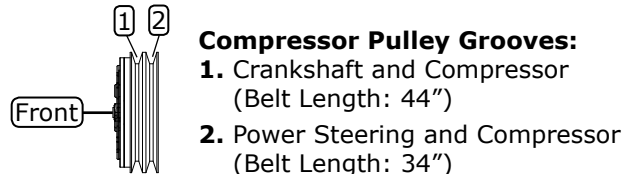
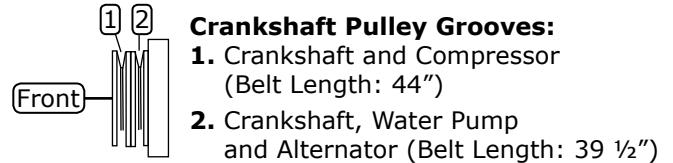
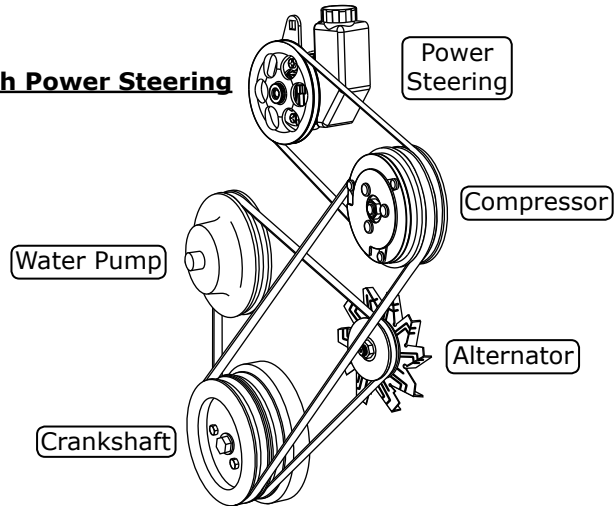

## Tightening Belts

1. Using a pry bar, adjust the belt tension on the alternator.
2. Using a 1/2" square-slot ratchet, adjust the belt tension on the compressor. **NOTE: The compressor bracket has a 1/2" square slot for adjusting belt tension.**
3. Using a 1/2" square-slot ratchet, adjust the belt tension on the power steering pump. **NOTE: The power steering bracket has a 1/2" square slot for adjusting belt tension. Do not apply pressure or torque to the power steering reservoir when tightening belts.**

## Compressor Warnings

**NOTE: Failure to follow these procedures may void all warranties.**

1. With compressor kit installed, and belt tightened, check angle of oil plug on compressor. As shown below, oil plug must not exceed 90° beyond vertical centerline.
2. Do not connect compressor clutch wire until system is being charged with refrigerant. Running compressor without refrigerant charge may result in compressor failure.

## IMPORTANT NOTICE:

- Do not connect compressor clutch wire until system is being charged with refrigerant. Since an A/C system relies on refrigerant to circulate lubricant, running the compressor without refrigerant may destroy the compressor and void the warranty.
- Proper compressor orientation is important. Sanden compressors may be rotated from vertical (oil fill plug at top) up to 90° in either direction (See illustration).

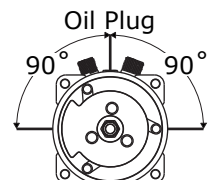





www.vintageair.com

# Packing List: Bracket Kit (131138)

No.	Qty.	Part No.	Description
1.	1	730010	Add-on Pulley, Black Hardcoat
2.	1	131136	Bracket Assembly, Compressor/Alternator
3.	1	146006-SCR	Bracket, Compressor Adjustment
4.	1	191046	Hardware Kit

Checked By: \_\_\_\_\_  
 Packed By: \_\_\_\_\_  
 Date: \_\_\_\_\_

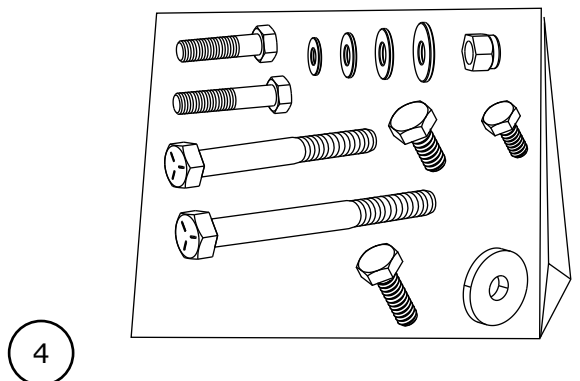
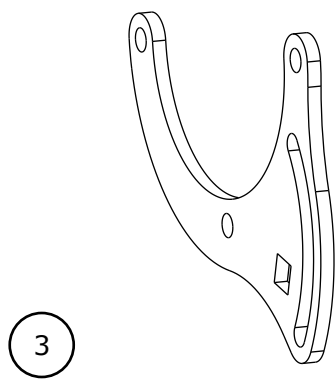
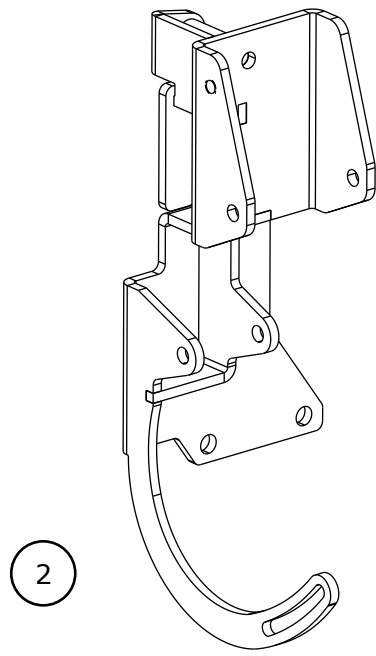
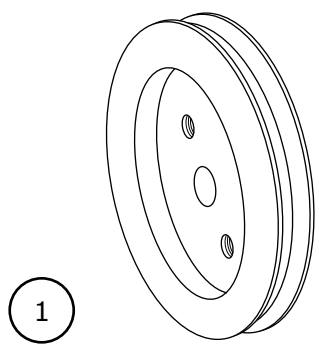

**NOTE: Images may not depict actual parts and quantities.  
 Refer to packing list for actual parts and quantities.**