



# 25L MICROWAVE OVEN WITH GRILL

KAMWO25GRLA



# SAFETY & WARNINGS

- Do not attempt to operate this oven with the door open, since open-door operation can result in harmful exposure to microwave energy. It is important not to defeat or tamper with the safety interlocks.
- Do not place any object between the oven front face and the door or allow soil or cleaner residue to accumulate on sealing surfaces.
- Do not operate the oven if it is damaged. It is particularly important that the oven door close properly and that there is no damage to the door, the hinges and latches, or the door seals and sealing services.
- The oven should not be adjusted or repaired by anyone except properly qualified service personnel.

**WARNING:** To reduce the risk of burns, electric shock, fire, injury to persons or exposure to excessive microwave energy, basic safety precautions should be followed, including those listed below.

- Read all instructions before using the appliance.
- Use this appliance only for its intended use as described in this manual. Do not use corrosive chemicals or vapours in this appliance. This type of oven is specifically designed to heat, cook, or dry food. It is not designed for industrial or laboratory use.
- Do not operate the oven when empty.
- Do not operate this appliance if it has a damaged cord or plug, if it is not working properly or if it has been damaged or dropped. If the supply cord is damaged, it must be replaced by Kogan.com to avoid a hazard.

**WARNING:** Only allow children to use the oven without supervision when adequate instructions have been given so that the child can safely use the oven and understands the hazards of improper use.

**WARNING:** It is hazardous for anyone other than a trained person to carry out any service or repair operation which involves the removal of any cover which gives protection against exposure to microwave energy.

- To reduce the risk of fire in the oven cavity:
  - When heating food in plastic or paper container, keep an eye on the oven due to the possibility of ignition.
  - Remove wire twist-ties from paper or plastic bags before placing the bag in oven.
  - If smoke is observed, switch off or unplug the appliance and keep the door closed to stifle any flames.
  - Do not use the cavity for storage purposes. Do not leave paper products, cooking utensils or food in the cavity when not in use.

**WARNING:** Liquid or other food must not be heated in sealed containers since they are liable to explode.

- Microwave heating of beverage can result in delayed eruptive boiling; care must be taken when handling the container.
- Do not fry food in the oven. Hot oil can damage oven parts and utensils and even result in skin burns.
- Eggs in their shell and whole hard-boiled eggs should not be heated in microwave ovens since they may explode even after microwave heating has ended.
- Pierce foods with heavy skins such as potatoes, whole squashes, apples, and chestnuts before cooking.
- The contents of feeding bottles and baby jars should be stirred or shaken, and the temperature should be checked before serving to avoid burns.
- Cooking utensils may become hot because of heat transferred from the heated food. Potholders may be needed to handle the utensil.
- Utensils should be checked to ensure that they are suitable for use in a microwave oven.
- This appliance is not intended for use by persons (including children) with reduced physical, sensory or mental capabilities or lack of experience and knowledge unless they have been given supervision or instruction concerning use of the appliance by a person responsible for their safety.
- Children should be supervised to ensure that they do not play with the appliance.

# OVERVIEW

## Part Name

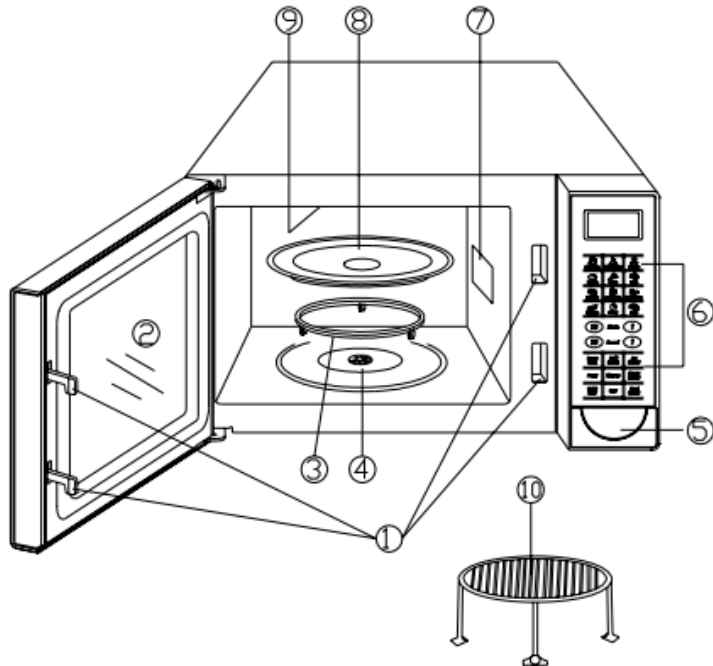

1	Door Safety Lock System	6	Control Panel
2	Oven Window	7	Wave guide
3	Roller Ring	8	Glass Tray
4	Shaft	9	Heater
5	Door Release Button	10	Metal Rack

## Control Panel

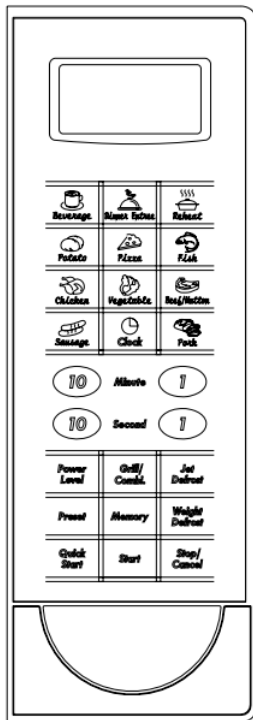

### Menu action screen:

Cooking time, power, action indicators and clock time are displayed.

### Number pads:

Touch to set the clock, cooking time or enter food weight.

### Quick cook buttons:

Instant settings to cook popular foods.

### Clock:

Touch to set the digital clock.

### Power level:

Used to set a microwave-cooking program.

**Grill/combi:**

Press up to three times to choose a cooking mode.

**Weight defrost:**

Programmed defrosting based on the weight of the foods to be defrosted.

**Jet defrost:**

Jets defrost function that alternates defrosting and standing times to defrost foods quickly and effectively.

**Preset:**

Preset control allows you to put food into the oven and program it to start cooking at a later time.

**Memory:**

Used for setting a multistage cooking program

**Start:**

Touch to start

**Quick start:**

Touch to start cooking or start the oven quickly.

**Stop/cancel:**

- Touch to clear entry before setting a cooking program
- Touch once to temporarily stop cooking or twice to cancel cooking.
- Touch and hold to set child lock.

# INSTRUCTIONS

If the oven fails to operate:

1. Check to ensure that the oven is plugged in securely. If it is not, remove the plug from the outlet, wait 10 seconds and plug it in again securely.
2. Check for a blown circuit fuse or a tripped main circuit breaker. If these seem to be operating properly, test the outlet with another appliance.
3. Check to ensure that the control panel is programmed correctly, and the timer is set.
4. Check to ensure that the door is securely closed engaging the door safety lock system. Otherwise, the microwave energy will not flow into the oven.

If none of the above rectifies the situation, contact Kogan.com. Do not try to adjust or repair the oven yourself.

## Grounding instructions

This appliance must be grounded. This oven is equipped with a cord having a grounding wire with a grounding plug. It must be plugged into a wall receptacle that is properly installed and grounded. In the event of an electrical short circuit, grounding reduces the risk of electric shock by providing an escape wire for the electric current. It is recommended that a separate circuit serving only the oven be provided. Using high voltage is dangerous and may result in a fire or other accident causing oven damage.

**WARNING:** Improper use of the grounding plug can result in a risk of electric shock.

### Note:

If you have any questions about the grounding or electrical instructions, consult a qualified electrician or service person.



## Setting the oven controls

To enter the digital clock time, touch the CLOCK button once and then press the number pads to set the time of day.

1. Touch CLOCK button,
2. Touch number pads to set the clock time.
3. Touch CLOCK button again to confirm.

### Note:

You can check the clock time when cooking is in progress by touching the CLOCK button.

## Microwave cooking

To cook with microwave, time and power level should be set. The longest cooking time to be set by touching the number pads is 99 min. 99 sec.

1. Touch Power Level button several times to set power level.
2. Touch number pads to set the cooking time.
3. Touch "Start" button.

### Note:

During cooking, press POWER LEVEL to show the cooking power level for 3 sec.

Microwave power levels:

Press	Power Level	Description
Once	100% of total	High
Twice	80%	M. High
Thrice	60%	Medium
4 times	40%	M. Low
5 times	20%	Low
6 times	0%	Zero

## Grill cooking

Grill cooking is particularly useful for thin slices of meat, steaks, chops, kebabs, sausages or a piece of chicken. It is also suitable for hot sandwiches and au gratin dishes.

1. Touch Grill/COMBI. button once.
2. Touch number pads to set the cooking time.
3. Touch START button.

## Combination cooking

The longest cooking time to be set by touching the number of pads is 99 min. 99 sec.

Combination 1:

35% time for microwave cooking and 65% for grill cooking. It is recommended for fish, potatoes, or au gratin.

Combination 2:

55% time for microwave cooking and 45% for grill cooking. Use for puddings omelettes, baked potatoes and poultry.

1. Touch Grill/COMBI. button twice or 3 times.
2. Touch number pads to set the cooking time.
3. Touch START button.

## Auto cook

For food or the following cooking mode, it is not necessary to program the duration and the cooking power. It is sufficient to indicate the type of food that you wish to cook as well as the weight of this food.

For example, to cook a certain amount of baked potato.

1. Place Potato in the oven.
2. Press POTATO several times to select weight.
3. Press the START button.

## Auto Cook Menu

Beverage (each 200ml)	For some food, at the middle of cooking time, beeps can be heard to remind you to open the door and check its doneness and turn food over to obtain uniform cooking, but be careful to handle hot food in the oven with care. To resume cooking, just close the door, the oven will cook for the remaining time.
Dinner entrée	
Reheat	
Fish	
Pizza	
Vegetable	
Potato	
Sausage	
Pork	
Beef/mutton	
Chicken	

## Weight defrosting

The oven allows the defrosting of meat, poultry, and seafood. The time and the defrosting power are adjusted automatically once the weight of food is programmed. The maximum allowable weight for each category is shown below.

Food Category	Maximum Weight	Display
Meat	2300g	d1
Poultry	4000g	d2
Seafood	900g	d3

1. Place food to be defrosted into the oven.
2. Touch WEIGHT DEFROST pad to select the food category (d1, d2 or d3)
3. Touch the 1 min. number pad to select the weight.

### Note:

Press the 10 min number pad to enter weight in 1kg increments, 1 min for 100g increments, 10 sec for 10g increments, and 1 sec for 1g increments.

During defrosting, the system will pause and sound to remind you to turn over the food. After turning the food, press START to resume.

4. Touch START pad.

## Jet defrosting

1. Touch JET DEFROST button.
2. Touch number pads to enter the defrosting time.
3. Touch START button.

### Note:

During defrosting, the system will pause and sound to remind you to turn over the food. After turning the food, press START to resume.

## Multi-stage cooking

The oven can be programmed to perform several consecutive functions.

Suppose you want to set the following cooking program:

- ① Jet defrost;
- ② Microwave cooking;
- ③ Grill cooking.

Steps:

1. If necessary, touch STOP/CANCEL pad once to reset the oven.
2. Input JET DEFROST program.
3. Press MEMORY pad.
4. Input microwave and power level cooking program.
5. Touch MEMORY pad.
6. Input grill cooking program.
7. Touch START pad.

### Note:

Jet Defrost or Weight Defrost should be included only when it is set foremost in a multistage cooking program.

The respective lights will come on to indicate which stage the oven is operating in. After the total time has elapsed, 4 beeps sound.

## Preset

The preset function allows the oven to start up in a later time.

1. Set a cooking program
2. Touch PRESET pad.
3. Use the number pads to enter the time when cooking should start.
4. Touch START pad.

### Note:

Make sure that the food is placed into the oven in advance before any cooking starts.

## Quick start

This feature allows you to start the oven quickly. Just touch QUICK START to set the cooking time, and the oven starts working immediately at full power.

## Child lock

Used to prevent unsupervised operation of the oven by little children. The child lock indicator will show up on the display screen and the oven cannot be operated while the child lock is set.

To set the child lock: Press and hold the STOP/CANCEL button for 3 seconds, a beep sounds and the LOCK indicator illuminates.

To cancel the CHILD LOCK: Press and hold the STOP/CANCEL button for 3 seconds until the lock indicator on display dims.

# INSTALLATION

- Make sure that all the packing materials are removed from the inside of the door.

**WARNING:** Check the oven for any damage, such as a misaligned or bent door, damaged door seals and sealing surfaces, broken or loose door hinges and latches, and dents inside the cavity or on the door. If there is any damage, contact [Kogan.com](http://Kogan.com) and refrain from operating the oven.

- This microwave oven must be placed on a flat, stable surface to hold its weight and the heaviest food likely to be cooked in the oven.
- Do not place the oven where heat, moisture or high humidity are generated or near combustible materials.
- For correct operation, the oven must have sufficient airflow. Allow 20cm of space above the oven, 10cm at back and 5cm at both sides. Do not cover or block any openings on the appliance. Do not remove the feet.
- Do not operate the oven without glass tray, roller support and shaft in their proper positions.
- Make sure that the power supply cord is undamaged and does not run under the oven or over any hot or sharp surface.
- The socket must be readily accessible so that it can be easily unplugged in an emergency.
- Do not use the oven outdoors.

# OPERATION

## Radio interference

Operation of the microwave oven can cause interference to your radio, TV, or similar equipment.

When there is interference, it may be reduced or eliminated by taking the following measures:

1. Clean door and sealing surface of the oven.
2. Reorient the receiving antenna of the radio or television.
3. Move the microwave oven away from the receiver.
4. Plug the microwave oven into a different outlet so that microwave oven and receiver are on different electrical circuits.

## Microwave cooking tips

1. Arrange food carefully. Place thickest areas towards outside of the dish.
2. Watch cooking time. Cook for the shortest amount of time indicated and add more as needed. Food severely overcooked can smoke or ignite.
3. Cover foods while cooking. Covers prevent spattering and help foods to cook evenly.
4. Turn foods over once during microwaving to speed cooking of such foods as chicken and hamburgers. Large items like roasts must be turned over at least once.
5. Rearrange foods such as meatballs halfway through cooking both from top to bottom and from the centre of the dish to the outside.

## Utensils guide

1. The ideal material for a microwave utensil is transparent to microwaves, allowing energy to pass through the container and heat the food.
2. Microwave cannot penetrate metal, so metal utensils or dishes with metallic trim should not be used.
3. Do not use recycled paper products when microwave cooking, as they may contain small metal fragments which may cause sparks and/or fires.
4. Round/oval dishes rather than square/oblong ones are recommended, as food in corners tends to overcook.
5. Narrow strips of aluminium foil may be used to prevent overcooking of exposed areas. Be careful not to use too much and keep a distance of 2.5cm between foil and the cavity.

Cookware	Microwave	Grill	Combination
Heat-resistant glass	Yes	Yes	Yes
Non heat-resistant glass	No	No	No
Heat-resistant ceramics	Yes	Yes	Yes
Microwave-safe plastic dish	Yes	No	No
Kitchen paper	Yes		No
Metal tray	No	Yes	No
Metal rack	No	Yes	No
Aluminium foil & foil containers	No	Yes	No

## SPECIFICATIONS

Power consumption	230V~50Hz, 1400W (microwave)
	1000W (grill)
Rated power output	900W
Operation frequency	2450MHz
Outside dimensions	281mm (H) x 483mm (W) x 396mm (D)
Oven cavity dimensions	220mm (H) x 340mm (W) x 344mm (D)
Oven capacity	25 litres
Cooking uniformity	Turntable system
Net weight	Approx. 14.5kg



# CLEANING & CARE

1. Turn off the oven and remove the power plug from the wall socket before cleaning.
2. Keep the inside of the oven clean. When food splatters or spilt liquids adhere to oven walls, wipe with a damp cloth. Mild detergent may be used if the oven gets very dirty. Avoid the use of spray and other harsh cleaners as they may stain, streak, or dull the door surface.
3. The outside surfaces should be cleaned with a damp cloth. To prevent damage to the operating parts inside the oven, water should not be allowed to seep into the ventilation openings.
4. Wipe the door and window on both sides, the door seals, and adjacent parts frequently with a damp cloth to remove any spills or splatters. Do not use abrasive cleaners.
5. Do not allow the control panel to become wet. Clean with a soft, damp cloth. When cleaning the control panel, leave the oven door open to prevent the oven from accidentally turning on.
6. If steam accumulates inside or around the outside of the oven door, wipe with a soft cloth. This may occur when the microwave oven is operated under high humidity conditions and is normal.
7. It is occasionally necessary to remove the glass tray for cleaning. Wash the tray in warm sudsy water or a dishwasher.
8. The roller ring and oven floor should be cleaned regularly to avoid excessive noise. Simply wipe the bottom surface of the oven with mild detergent. The roller ring may be washed in mild sudsy water or dishwasher. When removing the roller ring from the cavity floor for cleaning, be sure to replace it in the proper position.
9. Remove odours from your oven by combining a cup of water with the juice and skin of one lemon in a deep microwaveable bowl, then microwaving for 5 minutes. Wipe thoroughly and dry with a soft cloth.
10. When it becomes necessary to replace the oven light, please consult [Kogan.com](http://Kogan.com) to have it replaced.
11. The oven should be cleaned regularly, and any food deposits removed. Failure to maintain the oven in a clean condition could lead to deterioration of the surface that could adversely affect the life of the appliance and possibly result in a hazardous situation.
12. Please do not dispose of this appliance into the domestic rubbish bin; it should be taken to the disposal centre provided by your local municipality.





### **Need more information?**

We hope that this user guide has given you the assistance needed for a simple set-up. For the most up-to-date guide for your product, as well as any additional assistance you may require, head online to **[help.kogan.com](http://help.kogan.com)**

kogan