



CONSOLIDATED STERILIZER SYSTEMS

Consolidated Sterilizers *Designed to Transform Your Laboratory*

Models	
3AV (20" x 20" x 38")	
26AV (26" x 26" x 39")	
26BV (26" x 26" x 49")	
26CV (26" x 26" x 67")	

Small Lab Series Steam Sterilizers EZ-Glide™ Series General Specifications

General Specification

Consolidated EZ-Glide™ Series Sterilizers are designed to sterilize at temperatures between 212° F and 275° F (100° C and 135° C) through the use of steam. Choose from a stainless steel vessel construction in a variety of sizes and programmable control options for pre-vacuum or gravity operation. Consolidated sterilizers offer a range of performance options to meet the most demanding applications in clinical, animal and life science, biotechnology, pharmaceutical, and commercial/industrial applications.

Features and Benefits

Simplified Maintenance, Low Cost of Ownership.

All Consolidated sterilizers are manufactured in the USA and built from commonly available parts to allow quick and cost effective field-level service and maintenance.

Serviceability.

Easy access to replaceable components, local component availability and common electrical and plumbing parts permit qualified facility or area service companies to maintain the sterilizer.

Control Flexibility.

A choice of programmable controllers allows a broad range of performance functions, complete with alarm, monitoring and communications required for internal or third-party compliance.

Performance Cycles—Basic to Advanced.

The fully-jacketed sterilizer design permits vacuum and pressure control when configured for pre-vacuum, post-vacuum, and more sophisticated functions such as air-over-pressure. Consolidated sterilizers are ideal for sterilizing wrapped and unwrapped goods, liquids, waste, and other applications.

Green and Environmentally Friendly.

Unique, new technologies reduce water and energy consumption without compromising performance.

Cloud-Enabled

Consolidated sterilizers connect to the internet and are pre-configured for cloud-based monitoring, alerting and data collection.

Table of Contents

- Model Sizes and Weights.....2
- Sterilizer Construction.....2
- Sterilization Cycles.....6
- Options & Accessories.....8
- Installation.....9
- Footprint Drawings.....10
- Utility Information.....12



Consolidated EZ-Glide™ Series Sterilizers are available in single door models. A versatile control system offers a range of performance options to meet the most demanding applications in clinical, life science, biotechnology, pharmaceutical, and commercial/industrial applications. Model 3AV-ADV-PRO shown with ADV-PRO programmable logic controller.

MODEL SIZES & WEIGHT

Summary Selection Chart

Model	Chamber Dimensions (w x h x f-b)	Volume (cu. ft./liters)	Ship Weight (lbs/kg)	Overall Dimensions (w x h x f-b)
Sliding Door Model				
				
3AV	20" x 20" x 38" 50.8 x 50.8 x 96.5 cm	8.8 cu. ft. 249 liters	1650 lbs 750 kg	39.375" x 71" x 47" 100 x 180.3 x 119.4 cm
26AV	26" x 26" x 39" 66.04 x 66.04 x 99.1 cm	15.25 cu. ft. 431.8 liters	2600 lbs 1179 kg	46.375" x 77.25" x 54" 117.8 x 196.2 x 137.2 cm
26BV	26" x 26" x 49" 66.04 x 66.04 x 124.5 cm	19.2 cu. ft. 543.7 liters	2850 lbs 1293 kg	46.375" x 77.25" x 64" 117.8 x 196.2 x 162.6 cm
26CV	26" x 26" x 67" 66.04 x 66.04 x 170.2 cm	26.2 cu. ft. 742 liters	3350 lbs 1520 kg	46.375" x 77.25" x 82" 117.8 x 196.2 x 208.3 cm

High Performance Sterilization

Consolidated sterilizers are used in a wide range of applications including clinical, animal and life science, biotechnology, pharmaceutical, and commercial/industrial markets. Consolidated sterilizers are suitable for conventional or pre-vacuum sterilization for quality control, safety and regulatory compliance. In addition, all units can be customized to suit any unique requirements and applications of a particular facility.

Consolidated uses only commonly-available, open-source parts in all phases of sterilizer design and construction, thereby permitting quick, economical and locally-managed service throughout the life of the product. With maximum uptime engineered into the product, Consolidated sterilizers offer a superior return on investment as demonstrated through thousands of installations worldwide.

STERILIZER CONSTRUCTION

Sterilizer Chamber

Consolidated steam sterilizer vessels are manufactured with an inner chamber and a full outer jacket. The inner chambers are available in either Type 316L stainless steel or nickel-clad steel construction. Jacket construction is available in carbon steel, Type 304L stainless steel or Type 316L stainless steel. Material selection is directly related to the chemical properties of available water supply and intended application. All vessels with Type 316L stainless steel inner chambers are polished to a high luster finish and passivated. Pressure vessels are welded in compliance with ASME Section VIII, Division I.

EZ-Glide™ Sliding Door

- The EZ-Glide™ sliding door steam sterilizer simplifies chamber access with a sliding counterbalanced door that seals safely against an air actuated non-stick gasket.
- The gasket is recessed into a precision-machined slot and will maintain a secure seal even in the event of a total utility loss. The gasket is easy to replace and does not require special tools or lubrication.
- The door sealing mechanism includes redundancy for added security; a safety lock prevents the door from opening if the chamber is under pressure.

- Ergonomic benefits include a wide-grip handle and smooth, vertical open/close action on a counterbalanced assembly that is easy-to-operate with one-hand access.
- Standard configuration is manual operation. One-touch, automatic power door configuration is available as an option.
- Safety features
 - Low closing force, can be stopped with minimal pressure.
 - Powered door is closed using a push and hold button.

Chamber Door and Gasket System.

Consolidated's sterilizer doors are designed with redundant, and independent mechanical and software features to ensure maximum safety. Door design specifications meet all ASME code requirements.

- Door engagement is clearly visible to confirm closure.
- An electrical door switch ensures that the door is fully closed and locked prior to the start of the cycle. If the signal is lost during a sterilizing cycle, the cycle is automatically aborted.
- The door is mechanically locked during a cycle to prevent inadvertent opening.
- Abrasion resistant, low-friction sealant on gasket prevents door jams and extends gasket life.

Components

- Piping, fittings, and valves are available in stainless steel or brass/bronze. All parts and components subject to repair are publicly available (i.e. non-proprietary) from open market sources, including controls, valves and fittings.
- Safety relief valves and drains are integral to the plumbing configuration.
- Baffled steam inlets minimize direct condensate on the load, reduce load wetting, and help assure proper steam uniformity within the chamber.
- Cabinet insulation retains heat and minimizes heat loss (see Table 10) to the room. The sterilizer jacket and all steam service piping include a minimum 1" fiberglass-based insulation.
- An integral wastewater cooling function reduces discharge temperature to the drain to less than 140° F (60° C).
- On units equipped with steam generators, a manual reset pressure switch is included to back up the safety relief valve by automatically shutting down the steam generator if an overpressure condition exists.
- Easy-to-read pressure gauges ensure simple and safe operation.
- Other components required for the intended application may include a steam generator, vacuum pump, water ejector, etc. depending on the options chosen.

Control and Monitoring System

Consolidated offers a variety of control system options for programmed, automatic and semi-automatic operation. Controllers are built from industry standard, open source components for international availability of parts and service. Consolidated's Advantage Series™ controllers offer proven reliability. Controllers are based on the Allen-Bradley® PLC platform specifically programmed for Consolidated sterilizers, complete with intuitive touchscreen displays and real-time operating systems (see chart on page 4).

- Permits industry standard and custom sterilizer cycles.
- Simplifies operation with intuitive operator interfaces.
- Assures quality control and process integrity.
- Features sterilizer cycle quality reporting and printed documentation.

- Audible and visual alarms warn of cycle or other deviations.

Cloud-Based Monitoring and Data Collection

All Consolidated sterilizers have the ability to connect to the internet (via Ethernet or Wi-Fi) to allow remote monitoring, alerting and data collecting. All data is secured using HTTPS/TLS encryption and protected using 2-factor authentication. This system has the following capabilities:

- View the real-time status of the autoclave from any computer, smart phone or tablet using a standard web browser.
- Subscribe to and receive SMS/text and email alerts regarding cycle completion, cycle abort, alarm conditions, PM reminders and usage tips.
- View and download historical cycle data showing User ID, cycle name, cycle time, cycle completion status and all errors or alarms, as applicable.

Calibration

Sterilizers can be calibrated using three-point calibration method.

Printer

An impact printer or thermal printer can be integrated into the main control panel. Printout includes all important information regarding the sterilization cycle recorded at user-defined intervals. Information includes: operator identification code, cycle type, cycle phase, time, chamber and jacket pressure and/or temperature, alarms or messages and cycle completion status.

Alarms

Detailed performance and function alarms are based on the control system selection. Regardless of control system used, however, standard safety alarms are included in all Consolidated sterilizers.

Cycle Safeguards

The following cycle safeguards help assure safe operation.

- No cycle can start unless the door is properly closed and locked.
- Control inputs automatically reject incorrect cycle parameters.
- Chamber gauges are installed on the operating end of the sterilizer to display pressure in psig and vacuum in inches-Hg.
- Exhaust is automatically condensed and cooled to a safe drainage temperature.
- Multi-rate liquid exhaust allows users to select an exhaust rate above and below an adjustable temperature set-point. Prevents boil-over of liquids and reduces total cycle time.

Steam Sources

Consolidated sterilizers can operate on house steam or steam produced by integral or remote steam generators. Incoming water quality is always a primary consideration in selection of a steam generator (see Table 9).

Selection of the steam source is based on facility steam availability and other factors associated with sterilizer use and throughput.

House Steam

In most situations standard house steam, when available, is adequate. An inlet steam filter may be required to clean the steam prior to injection into the sterilizer plumbing system.

Electric Steam Generator

When house steam is not available, an electric boiler must serve as the steam source. Higher wattage generators produce a higher rate of steam to the chamber. Standard voltages available are 208, 240, 380, 480. Three-phase or single-phase voltage connections are available.

- **Integrated Boiler.**

Consolidated can provide an integral (fits under the sterilizer chamber) steam generator up to 45 kW.

A standard steam boiler, constructed of carbon steel, is utilized on units fed with tap, softened or RO water. (See Table 9 for water quality requirements).

A clean steam boiler, constructed of type 316L stainless steel, is required when the water quality feed is >1 MΩ•cm. This option typically requires that the sterilizer be constructed with a stainless-steel chamber, jacket, and plumbing.

- **Remote Boiler.**

Steam generators >45 kW are typically too large to fit beneath the sterilizer chamber and must be remote mounted.

Electric/Steam Combination

Sterilizers can be configured to accommodate both house steam and an integral electric generator. This feature allows for easy switching between either steam sources.

Steam-to-Steam Generator

A steam-to-steam generator delivers clean steam to the sterilizer. Contact Consolidated for details and ordering information.

Generator Blowdown

In facilities where water quality is poor, a generator blowdown function is required to flush impurities from the system and prevent collection of contaminants on the heating elements. The blowdown function can be initiated manually or ordered as an automatic blowdown function if desired.

Air Removal

Depending on the application and required cycle, air removal may be achieved by gravity displacement or mechanical assistance through vacuum for pre- and post-cycle use as required.

- For gravity air removal, the control system automatically opens and closes valves on demand.
- For pre-cycle vacuum, Consolidated offers a choice of a water-ejector vacuum system, or a water-minimizing liquid ring pump.
- For post-cycle vacuum where drying assistance is desired, the sterilizer can use a water-ejector vacuum system or a water-minimizing liquid ring pump.
- Following completion of the post-vacuum function and throughout return to ambient pressure equilibrium, the returning air is filtered through a 0.3 micron bacteria-retentive HEPA filter.

Consolidated Sterilizer Systems Controller Options— The Advantage Series™ Programmable Logic Controllers

Controllers	ADV-PRO™	ADV-PLUS™	ADV-PB™
Description	Color Touchscreen Display	Monochrome Touchscreen Display	Monochrome Touchscreen Display w/ Push Buttons

Operator Interfaces

Display	6" 18 bit color	10" 18 bit color	7" Monochrome	3" Monochrome
Resolution	320 x 240 pixels	640 x 480 pixels	800 x 400 pixels	128 x 64 pixels
Mounting Options	Front and Remote Panel		Front and Remote Panel	Top, Front and Remote Panel
Chamber Process Gauges	Pressure (psig, kg/cm ²) Vacuum (inHg, mmHg)		Pressure (psig, kg/cm ²) Vacuum (inHg, mmHg)	Pressure (psig, kg/cm ²) Vacuum (inHg, mmHg)

Industry Standard and Custom Sterilizer Cycles

Gravity	Standard	Standard	Standard
Liquids w/Auto Jacket Blowdown	Standard	Standard	Standard
Liquids w/Controlling Load Probe	Optional	Optional	
Pre-Vacuum	Optional	Optional	
Post-Vacuum Drying	Optional	Optional	Optional
Low Temperature (Isothermal)	Optional	Optional	
Bowie-Dick (Air Removal Test)	Optional	Optional	
Vacuum Leak Test	Optional	Optional	
Air-Over-Pressure	Optional		
Effluent Decontamination	Optional		
F ₀ w/ Controlling Load Probe	Optional		
Total Programmable Cycles	Up to 22	Up to 12	2

Green Features

Energy Saver Eco Calendar for Scheduled ON/OFF Steam Supply	Standard	Standard	
WaterEco™ System for Reduced Water Consumption	Optional	Optional	Optional

Sterilizer Control and Process Integrity

Configurable Cycle Parameters	Standard	Standard	Standard
Improper Parameter Rejection	Standard	Standard	Standard
Multi-layered Password Security for Configuration Protection	Standard	Standard	
Two-Point Calibration of Sensors	Standard	Standard	Standard
Automatic Condensate Exhaust Management for all Cycles	Standard	Standard	Standard
Memory Backup of Configuration	Standard	Standard	Standard

Sterilizer Cycle Quality Reporting

Graphic Display of Cycle Progress	Standard	Standard	Standard
Thermal Printer (48 characters/line)	Standard		
Impact Printer (48 characters/line)	Optional	Standard	Standard

Printed Documentation of Sterilizer Cycles

User Defined Cycle Name	Standard		
Start Time and Date	Standard	Standard	Standard
Cycle Type	Standard	Standard	Standard
Chamber Temperature/Pressures	Standard	Standard	Temperature Only
Cycle Summary	Standard	Standard	Standard

Audible Alarms (Also Displayed on Touchscreen)

Cycle Completed, Recycle, Over Temperature, Over Pressure, Time Limit, Chamber Drain, Jacket/Chamber Flow Failure	Standard	Standard	Standard
---	----------	----------	----------

Connectivity

Cloud-Based Monitoring & Data Collection	Standard	Standard	Standard
SteriNET® Connex (Remote Troubleshooting)	Optional	Optional	Optional
SteriNET® Dataport	Standard Ethernet, Optional RS-232	Standard Ethernet, Optional RS-232	Standard Ethernet



- A. Hinged front panels for easy access
- B. EZ-Glide™ vertical sliding door
- C. ProGEN™ electric steam generator (optional)
- D. Advantage Series™ control column

Model 3AV (Front View) Service access panels on left- and right-hand hinges place all interior components and plumbing within easy reach and front access. Controls, printers, communications, electrical, mechanical and plumbing circuits are positioned for proactive maintenance.

Shelving

Shelves, carts and other accessories are available to suit specific applications. Shelves and racks are constructed of electro-polished Type 316L stainless steel. Interior shelving options include:

- Standard: One (1) stationary full-length wire-grid bottom shelf and one (1) upper stationary shelf suspended in the middle of the chamber on shelf brackets.
- Option 1: One (1) stationary full-length wire-grid bottom shelf and one (1) upper extendable shelf suspended in the middle of the chamber on shelf brackets.
- Option 2: One (1) stationary full-length wire-grid bottom shelf and two (2) upper extendable shelves suspended on two evenly spaced supports.

Sterilizer Mounting

Consolidated sterilizers are available for installation as floor-standing cabinet-enclosed units with a stainless-steel superstructure to conceal plumbing and wiring. These sterilizers are also available for installation as recessed in one wall. Hook-ups for utility connections can be located anywhere on the unit as required, however house connections must be within 5 feet of the unit unless otherwise specified prior to installation.

Water Quality Compatibility (Stainless Steel vs. Non-Stainless Selection)

Materials that contact the water supply to the sterilizer, including the steam generator, water-cooled devices, water-actuated accessories, valves and piping must be compatible with the purity of the water.

- If deionized or distilled water or water with a purity greater than 1 MΩ•cm is supplied, then all such points of contact must be of stainless steel construction.
- If softened water, water purified by reverse osmosis or tap water with purity of less than 0.2 MΩ•cm is supplied, then such points of contact must be of carbon steel, bronze or brass construction, as appropriate.

Compliance and Certifications

Depending on desired application, Consolidated sterilizers can be certified for compliance to the following standards for performance and safety.

- ASME (American Society of Mechanical Engineers): Section VIII, Division I (Unfired Pressure Vessel) code.
- ASME: Section I Code (Miniature Boilers).
- CRN (Canadian Registration Number): requirements for pressure vessels.
- IEC (International Electrotechnical Commission):
 - EN 61010-1:96—Safety requirements for electrical equipment for measurement, control, and laboratory use.
 - EN 61010-2-041:96—Specific requirements for steam autoclaves.
- UL and cUL (Underwriters Laboratory): Standard 61010-1 and 61010-2.
- US NEC (National Electrical Code) and National Plumbing Code; NFPA-70.
- EN ISO 111345-R-8/93—AAMI (Association for the Advancement of Medical Instrumentation) Industry Standard for Moist Heat Sterilization.
- 21 CFR Part 11 (US Code of Federal Regulations, Section 21—Food and Drugs; Electronic Records; Electronic Signatures).
- ANSI/AAMI ST-8: Hospital Steam Sterilizers.

Extra pressure is achieved using a house air source. Available on gravity and pre-vacuum units. Useful for rapidly cooling liquid media via an interior water spray mechanism or jacket quench, post-sterilization.

F₀ Cycle

Available on gravity and pre-vacuum units. Useful for heat-sensitive liquid media. Sterilization begins when temperature reaches 212°F and is completed when the F₀ set-point is reached. F₀ is adjustable.

Temperature/Pressure Ramping

Available on gravity and pre-vacuum units. Allows the user to specify a) the amount of time it takes for the load to rise to sterilization temperature/pressure and b) the amount of time it takes to exhaust the sterilizer chamber post-cycle. Ideal for loads that are sensitive to rapid pressure changes.

Continuous

Any sterilization cycle can be programmed to be continuously repeated (number of times is adjustable) without any input from the operator. Used for product lifecycle testing.

Steam-Air Mix

Useful for liquid-filled syringes or other sealed containers. Sterilization occurs at an elevated pressure relative to temperature. Extra pressure is achieved using a house air source.

Sterilization Cycles

Consolidated sterilizers can be easily configured for numerous cycles and functions. Each cycle is customizable to meet user specific requirements. All cycle parameters are easily viewed prior to and during the cycle run. The following cycles are pre-configured and installed on all sterilizers:

Gravity

The gravity cycle uses gravity to displace the air in the chamber with pressurized steam. This cycle is used mainly for unwrapped goods. The operator may select a sterilization temperature anywhere between 212° F and 275° F (100° C and 135° C), as well as sterilization time and dry time (see Figure 1).

Liquids

The liquid cycle prevents boil-over when vented liquids are sterilized. The controller is factory-configured to automatically release steam pressure at an adjustable exhaust rate. The operator may select a sterilization temperature anywhere between 212° F and 275° F (100° C and 135° C), as well as sterilization time (see Figure 2).

Additional Sterilization Cycles (available upon request)

Gravity with Post-Vacuum Drying

Available on gravity and pre-vacuum units. This cycle draws a vacuum following sterilization and significantly decreases drying time. Post-vacuum is usually used for wrapped goods, fibers, rubber, bedding, glassware and similar loads. The operator may select a sterilization temperature anywhere between 212° F and 275° F (100° C and 135° C), as well as sterilization time and dry time (see Figure 4).

Liquids with Load Probe

Available on gravity and pre-vacuum units. This cycle uses a temperature probe placed within the liquid load to detect, display and print temperature. Applications include sterilization of temperature-sensitive liquids or large volume liquid sterilization (i.e. >2 liter flasks).

Pre-Vacuum

Available only on pre-vacuum units. This cycle performs a series of steam pulses and vacuum draws prior to sterilization to assure that air has been removed from the load. This also permits the ability to vacuum dry. The number of pulses, pulse steam pressure, vacuum pulse pressure, sterilization time and temperature, and dry time are customizable for each cycle (see Figure 3).

Bowie-Dick (Air Removal Test)

Available on pre-vacuum units. This air-removal test cycle validates the vacuum function using ad hoc test packs as per requirements listed in AAMI ST-8.

Vacuum Leak Test

Available on pre-vacuum units. This cycle provides easy verification of vacuum depth, vacuum seal and chamber piping integrity. Detects leaks greater than 1 mmHg (1 Torr) per minute.

Effluent Decontamination

Available on gravity and pre-vacuum units. Retains liquid effluent, if any, within the chamber for the duration of the sterilization cycle. Aerosol effluent passes through a 0.2 micron hydrophobic HEPA filter with >99.999% efficiency; the filter is located within the chamber and is sterilized *in situ* to eliminate the need for disposal after each cycle. The filter is easily replaced by the user when required without special tools or service personnel.

Air-Over-Pressure

Available on gravity and pre-vacuum units. This cycle uses compressed air to maintain chamber pressure at the sterilization pressure until the liquid has cooled to a user adjustable temperature. This is useful for small volumes of liquid susceptible to boil-over (see Figure 5).

Low Temperature

Available on gravity and pre-vacuum units. Typically used for temperature-sensitive goods, this function creates a zero-pressure, temperature only cycle between 190° F and 212° F (88° C and 100° C). Often referred to as an isothermal or inspissation cycle.

Rapid Cooling

Available on gravity and pre-vacuum units. Useful for rapidly cooling liquid media via an interior water spray mechanism or jacket quench, post-sterilization.

F₀ Cycle

Available on gravity and pre-vacuum units. Useful for heat-sensitive liquid media. Sterilization begins when temperature reaches 212°F and is completed when the F₀ set-point is reached. F₀ is adjustable.

Temperature/Pressure Ramping

Available on gravity and pre-vacuum units. Allows the user to specify a) the amount of time it takes for the load to rise to sterilization temperature/pressure and b) the amount of time it takes to exhaust the sterilizer chamber post-cycle. Ideal for loads that are sensitive to rapid pressure changes.

Continuous

Any sterilization cycle can be programmed to be continuously repeated (number of times is adjustable) without any input from the operator. Used for product lifecycle testing.

Steam-Air Mix

Useful for liquid-filled syringes or other sealed containers. Sterilization occurs at an elevated pressure relative to temperature. Extra pressure is achieved using a house air source.

Sterilizer Cycle Selection

Gravity. (Figure 1)

Steam flows through the sterilizer; temperature and pressure ramps slightly to a continuous flow purge.

The controller closes the exhaust valve and interior temperature and pressure ramp up to desired setpoint.

The program maintains dwell until desired time is reached, when pressure is released.

The interior is restored to ambient pressure although contents remain relatively hot.

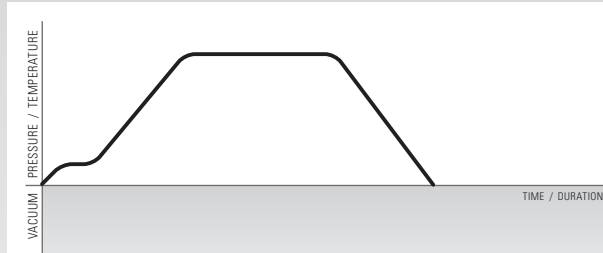

Liquid. (Figure 2)

Steam flows through the sterilizer; temperature and pressure ramps slightly to a continuous flow purge.

The controller closes the exhaust valve and interior temperature and pressure ramp up to desired setpoint.

The program maintains dwell until desired time is reached. Pressure is gradually released to allow dissolved gases to reach equilibrium to prevent boil-over.

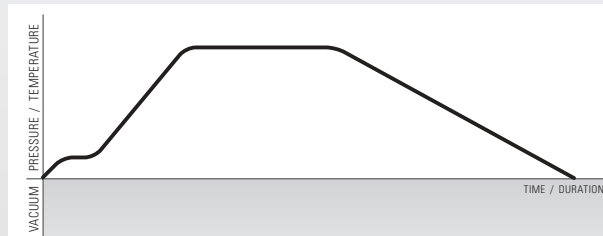

Pre-Vacuum with Post-Vacuum Drying. (Figure 3)

Steam flows through the sterilizer; temperature and pressure ramps slightly to a continuous flow purge.

The controller closes the exhaust valve and interior temperature and pressure ramp to an intermediate setpoint without dwell.

A vacuum system draws the interior atmosphere to negative pressure to remove latent air from concealed pockets within the load.

The process is repeated per program and protocol. Following the final pre-vacuum pulse, the sterilizer ramps to desired setpoint.

The program maintains dwell until desired time is reached, when pressure is released.

If a post-vacuum program is used, a vacuum system draws the interior atmosphere through ambient to negative pressure, accelerating drying time as programmed, after which the vacuum is released and the load is restored to ambient pressure.

If a post-vacuum program is not used, the load is restored to ambient pressure.

Pre-Vacuum with Post-Vacuum Drying. (Figure 3)

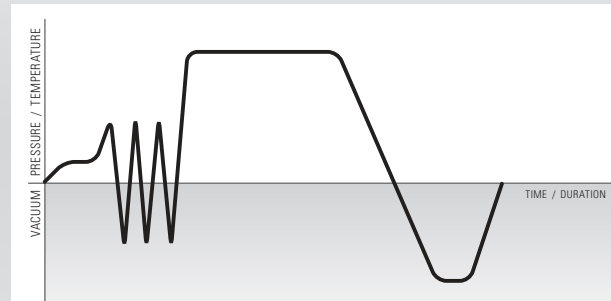

Gravity with Post-Vacuum Drying. (Figure 4)

Steam flows through the sterilizer; temperature and pressure ramps slightly to a continuous flow purge.

The controller closes the exhaust valve and interior temperature and pressure ramp up to desired setpoint.

The program maintains dwell until desired time is reached, when pressure is released.

A vacuum system draws the interior atmosphere through ambient to negative pressure, accelerating drying time as programmed.

Once completed the vacuum is released and the load is restored to ambient pressure.

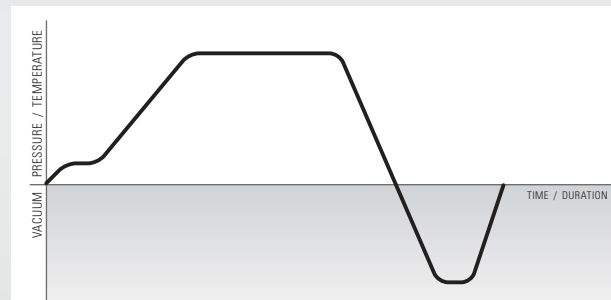

Liquid, Air-Over-Pressure. (Figure 5)

Usually used with smaller amounts of media to prevent liquid loss.

The air-over-pressure function operates identical to the liquid cycle except that pressurized air is injected to cool the load while maintaining pressure to displace steam.

After sterilization, air is injected, pressure is maintained, this prevents boil-over and minimizes evaporation.

Air pressure is then released and the load is restored to ambient pressure.

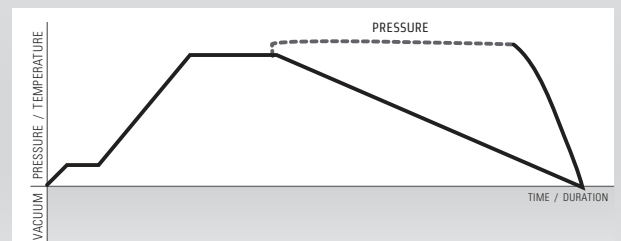

Options & Accessories

Consolidated offers a range of options and accessories to optimize and customize your sterilizer, to meet requirements for internal or third-party compliance, and to improve workflow. Some options are factory installed and must be specified when ordering. Contact Consolidated for detailed information on any of the following:

WaterEco® Water Saving Systems

The Consolidated WaterEco® Water Saving Systems reduce water consumption to the autoclave by up to 99%. Factory or field installed. Available on gravity and pre-vacuum units in the following configurations:

- **WaterEco® Basic:** Reduces cooling water by up to 90% without the use of electricity. This system functions by collecting autoclave drainage into a cooling reservoir. This effluent is cooled using a combination of air, previously cooled effluent and a minimal amount of cold water.
- **WaterEco® Plus:** Reduces water consumption by up to 99% through a stainless steel heat exchanger that utilizes facility chilled water supply. This system virtually eliminates once-through cooling water.
- **WaterEco® Vac Plus:** This full recovery system reduces water consumption by the vacuum system by up to 99%. Designed to integrate with pre-vacuum autoclaves when facility chilled water is readily available. This system is the best solution to minimize water consumption.

Water Purification System

High-purity water purification systems are available for facilities that do not meet the minimum water purity requirements (see Table 9) or that require clean steam. Option 1: A reverse osmosis (RO) water filtration system designed to pre-treat autoclave feed-water can be supplied (Model WPS-1200-RO). Option 2: If deionized water is required for clean steam generation, an RO/DI system that incorporates extra filtration to produce Type II deionized water (>1 MΩ resistivity) can be supplied (Model WPS-1200-DI).

Steam Generator

For installations where house steam is not available, a variety of integral or remote mounted steam generators is available. Consolidated will assist with selection according to site preparation requirements. Generators are available in electric, or steam-powered configurations. Integral generators are factory installed and must be specified when ordering.

Automatic Generator Blowdown

Recommended to remove accumulated impurities from the steam generator when used with low quality incoming water. Factory installed. Specify when ordering.

Steam Inlet Filter

Recommended to clean dirty steam (i.e. remove particulates) from facility steam sources. Specify when ordering.

Nickel-Clad Chamber

Recommended chamber material for sterilizing high-concentration salt solutions or if the feed-water or tap-water for steam generation has high chloride content. Specify when ordering.



SteriNET® Remote Monitoring and Troubleshooting

SteriNET® Connex permits Consolidated engineers to provide quick, accurate and economical offsite diagnosis of operation problems through a standard phone line or Ethernet connection. This option is ideal for facilities located

in remote areas where service assistance is hours or days away. This option includes one year of free, remote-transmitted software upgrades from the Consolidated technical support center.

RS-232 Port

Connects the control system to data logging/monitoring equipment. Factory installed. Specify when ordering.

Steril-Q™ Validation Services & Documentation

Protocols and templates are available for Factory Acceptance Testing (FAT), Installation Qualification (IQ), Operation Qualification (OQ), Performance Qualification (PQ) and steam Quality (SQ) testing. Specify when ordering.

Load Probe

Includes a temperature probe with lead wire permitting placement in the load to be sterilized such as liquid, red-bag or other. Sterilization cycle time is based on load temperature instead of chamber temperature. Factory installed. Specify when ordering.

Multi-Probe Sealing Gland

Multi-port gland permits safe installation of thermocouples or other probes inside the chamber. Factory installed. Specify desired quantity and location when ordering.

Automatic Jacket Blowdown

Recommended for liquid cycles. This option is used to exhaust steam in the chamber as well as the jacket to prevent liquid loads from boiling over. Factory installed. Specify when ordering.

Seismic Anchorage Details

May be required to meet building codes in seismically active areas. Contact your facility manager to determine if required. If ordered, Consolidated will provide anchor attachment points and suggested seismic anchorage details. Specify when ordering.

Sump Pump

Required when gravity drain is not available. Provides positive pump to remove condensate effluent to hard-plumbed drain. Specify when ordering.

Form C Dry Contacts

Offers direct connection to building monitoring system (120 VAC output). Specify desired outputs when ordering: door open/close, power on/off or sterilize alarm conditions. Specify when ordering.

Chamber Finish

- High polish (mirror finish), less than 10Ra.
- Passivation and Electropolish.

Stainless Steel Piping

- Upgrade from brass/bronze piping & components to type 316 stainless steel for all product wetted surfaces.

Flood Switch

In the event of excessive liquid in the chamber or jacket, an alarm will sound and a message will be displayed warning the user about the flood condition. Factory installed. Specify when ordering.

Uninterruptible Power Supply (UPS)

Allows the control system to remain on in the event of a brief power loss or brownout. Specify when ordering.

Loading Cart & Transfer Carriage

A loading cart, mounted on rollers, with two stainless steel shelves and a wheeled transfer carriage. The transfer carriage mates to interior guide rails to ease loading and unloading of sterilization loads up to 500 lbs evenly distributed.



Site Preparation and Utilities

General

Utilities of ample capacity required for operation of the sterilizer shall be provided at the place of installation at the facility. Key considerations include electric power availability, steam source, water type and flow capacity, and compressed air (if air-over-pressure cycle is desired). For information on required utilities and locations refer to the sterilizer architectural drawing.

- Drain and ventilation considerations include wastewater and the facility HVAC system.
- Clearances include door and cart allowances, recommended 18–24" for access to plumbing, adequate load-bearing capacity of floor at installation site, and biointegrity.
- Consider the location of sprinklers, smoke detectors, and canopy capture hoods.
- Contact Consolidated or your Consolidated sales representative for planning and selection assistance.

Installation

Consolidated offers a choice of installation options to accommodate the facility schedule. In general, Consolidated can arrange for any of the following installation preferences:

- **Level 1:** Sterilizer start-up and user training.
- **Level 2:** Sterilizer uncrating, setting in place, leveling, final assembly, start-up, and user training.
- **Level 3A:** Sterilizer uncrating, setting in place, leveling, final assembly, final utility connections, start-up, and user training.
- **Level 3B:** Receiving the shipment, sterilizer uncrating, setting in place, leveling, final assembly, start-up, and user training.
- **Level 4 (Turnkey):** Receiving the sterilizer, uncrating, setting in place, leveling, final assembly, final utility connections, start-up, and user training.
- **Installation Supervision:** Consolidated will supervise on-site installation work performed by facility designated labor.

Standard Mounting Configurations

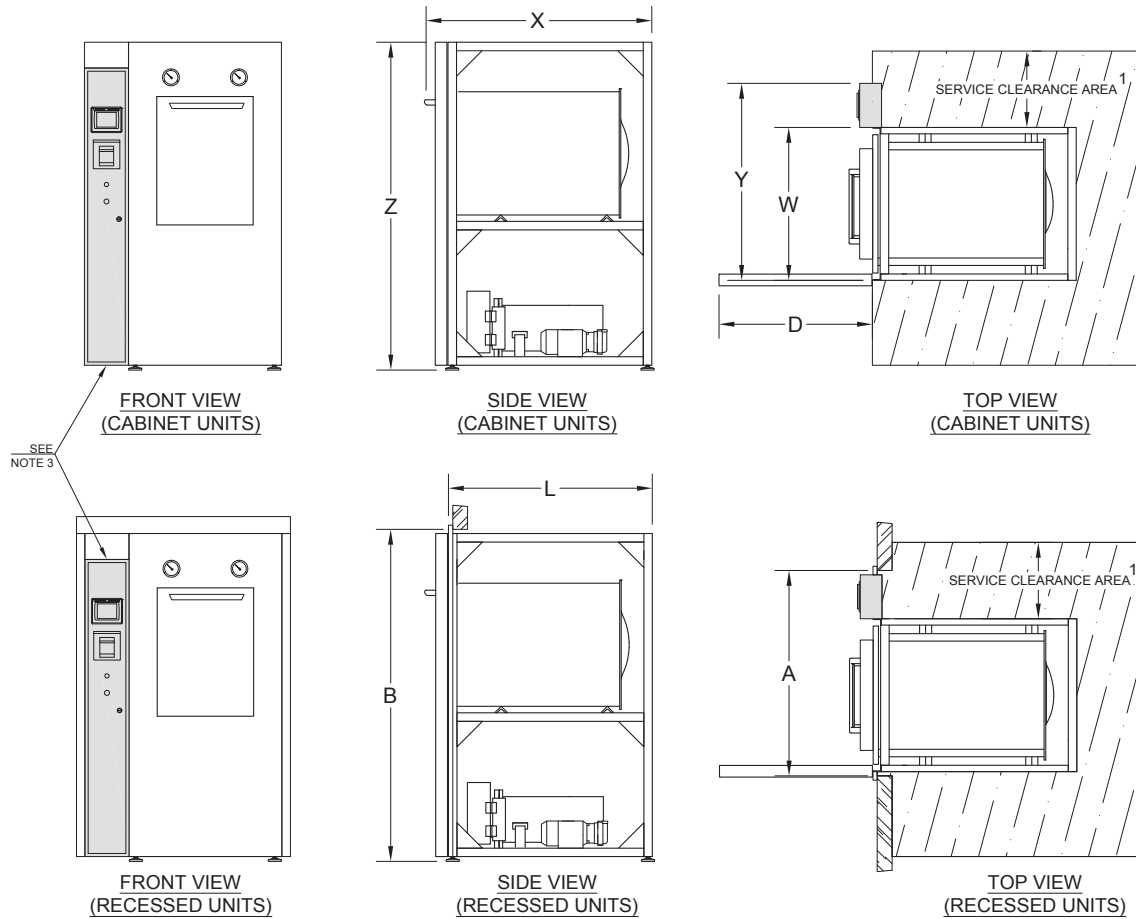

Table 1: Sterilizer Dimensions²

Model	3AV	26AV	26BV	26CV
Chamber Dimensions (w x h x f-b)	20" x 20" x 38" 50.8 x 50.8 x 96.5 cm	26" x 26" x 39" 66 x 66 x 99 cm	26" x 26" x 49" 66 x 66 x 124.5 cm	26" x 26" x 67" 66 x 66 x 170.2 cm
Volume	8.8 cu. ft (249 L)	15.3 cu. ft (433L)	19.2 cu. ft (543L)	26.2 cu. ft (742L)
Overall Length (X)	47" 119.4 cm	54" 137.2 cm	64" 162.6 cm	82" 208.3 cm
Overall Width (Y)	39.375" 100 cm	46.375" 117.8 cm	46.375" 117.8 cm	46.375" 117.8 cm
Overall Height (Z) ⁵ <i>Includes leveling feet</i>	71" 181.6 cm	77" 195.6 cm	77" 195.6 cm	77" 195.6 cm
Frame Length (L)	45" 114.3 cm	48" 121.9 cm	58" 121.9 cm	76" 193 cm
Frame Width (W)	29" 73.7 cm	36" 91.4 cm	36" 91.4 cm	36" 91.4 cm
Wall Opening Width (A)	41.5" 105.4 cm	48.5" 123.2 cm	48.5" 123.2 cm	48.5" 123.2 cm
Wall Opening Height (B)	74" 189.2 cm	80" 203.2 cm	80" 203.2 cm	80" 203.2 cm
Access Door Swing ⁷ (D)	29" 73.7 cm	36" 91.4 cm	36" 91.4 cm	36" 91.4 cm

- 1) Recommended service clearance is 18-24" both sides and back. If necessary, service clearance can be decreased to accommodate facility space requirements but some access on both sides is necessary for door service.
- 2) Additional options may require a larger footprint.
- 3) The control housing is shipped detached from the sterilizer to allow passage through doorways, reducing pre-installation Overall Width (Y) by 10.375". When the sterilizer is installed, the control housing and electrical connections are easily attached.
- 4) All views contain configuration specific components. These are for illustrative purposes only, actual configuration may vary.
- 5) After adjustment, leveling feet may add up to 1 inch to the Overall Height (Z).
- 6) Left side control housing with vertical sliding door is standard.
- 7) Service panel swings open at front for ease of access to components.
- 8) Power door only available on ADV-PRO.

This page shows a variant recessed mounting to allow a sterilizer to fit into an existing narrow wall opening.

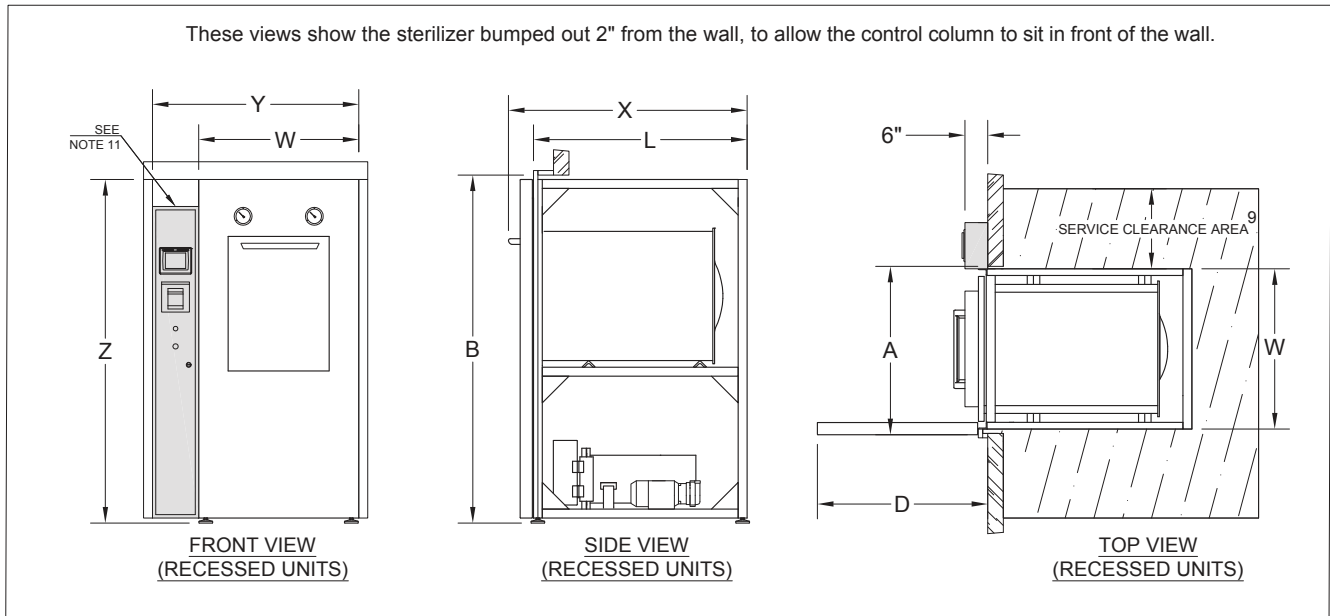

Table 2: Sterilizer Dimensions¹⁰

Model	3AV	26AV	26BV	26CV
Chamber Dimensions (w x h x f-b)	20" x 20" x 38" 50.8 x 50.8 x 96.5 cm	26" x 26" x 39" 66 x 66 x 99 cm	26" x 26" x 49" 66 x 66 x 124.5 cm	26" x 26" x 67" 66 x 66 x 170.2 cm
Volume	8.8 cu. ft (249 L)	15.3 cu. ft (433L)	19.2 cu. ft (543L)	26.2 cu. ft (742L)
Overall Length (X)	47" 119.4 cm	54" 137.2 cm	64" 162.6 cm	82" 208.3 cm
Overall Width (Y)	39.375" 100 cm	46.375" 117.8 cm	46.375" 117.8 cm	46.375" 117.8 cm
Overall Height (Z) <i>Includes leveling feet</i>	71" 181.6 cm	77" 195.6 cm	77" 195.6 cm	77" 195.6 cm
Frame Length (L)	45" 114.3 cm	48" 121.9 cm	58" 121.9 cm	76" 193 cm
Frame Width (W)	29" 73.7 cm	36" 91.4 cm	36" 91.4 cm	36" 91.4 cm
Wall Opening Width (A)	30" 76.3 cm	37" 94.1 cm	37" 94.1 cm	37" 94.1 cm
Wall Opening Height (B)	74" 189.2 cm	80" 203.2 cm	80" 203.2 cm	80" 203.2 cm
Access Door Swing ⁷ (D)	29" 73.7 cm	36" 91.4 cm	36" 91.4 cm	36" 91.4 cm

9) Recommended service clearance is 18-24" both sides and back.

10) Additional options may require a larger footprint.

11) The control housing is shipped detached from the sterilizer to allow passage through doorways, reducing pre-installation Overall Width (Y) by 10.375". When the sterilizer is installed, the control housing and electrical connections are easily attached.

Typical Utility Requirements

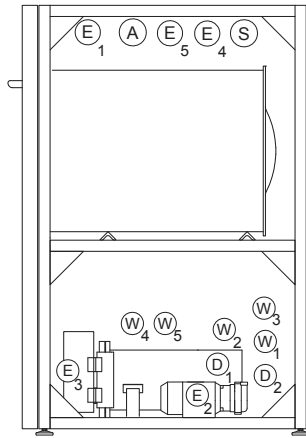

**SIDE VIEW
(CABINET UNITS)**

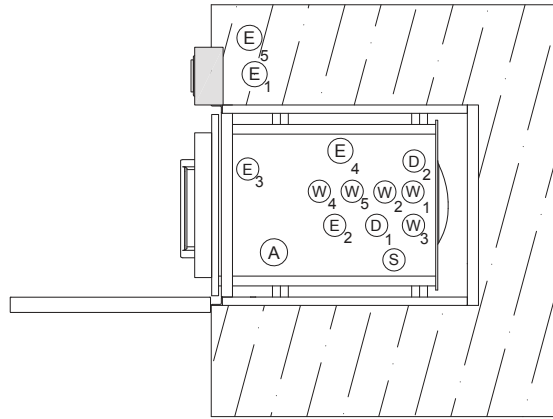

**TOP VIEW
(CABINET UNITS)**

UTILITY LEGEND

- E Electrical
- D Drain
- W Water
- S Steam
- A Air

Table 3: General Connections

Name	Symbol	Connection on Sterilizer	MEP Requirements ¹⁴
Wastewater Cooling	W ₁	½" NPT	45 psig dynamic min, 80 psig static max, ¾"-1" NPT, 12 GPM capacity, with shut off valve and union ¹²
Controls System	E ₁	NEMA 3-Prong Plug	110V/220V, 20 Amp minimum
Ethernet Port	E ₅	RJ-45	Standard RJ-45 ethernet cable with internet access
Sterilizer Drain	D ₁	1 ½" Sweat (NPT on units with WaterEco)	2 ½" air gap, 3" diameter minimum funnel required, location external to unit footprint recommended
Direct Steam (Optional)	S	½" NPT	50-80 psig dynamic, ¾" NPT, 180 lbs/hr capacity, insulated line with shut-off valve and union
Dry Contacts (Optional)	E ₄	2-Wire Terminal	Signal wires compatible with Form C Dry Contacts
Compressed Air (Optional)	A	½" NPT	50 psi dynamic min, 10-35 SCFM, 99% dry & oil free, backflow preventer not provided by CSS

Table 4: Optional Vacuum Systems (maximum one per unit)

Name	Symbol	Connection on Sterilizer	MEP Requirements ¹⁴
Economy Post-Vac	W ₂	½" NPT	45 psig dynamic min, 80 psig static max, ¾"-1" NPT, 12 GPM capacity, with shut off valve and union ¹²
Hi-Vac with Water Ejector	W ₂	½" NPT	45 psig dynamic min, 80 psig static max, ¾"-1" NPT, 12 GPM capacity, with shut off valve and union ¹²
Booster Pump	E ₂	Hard Wire	115V/208-230V, single phase, minimum 20 Amp circuit required
Vacuum Pump - Electrical	E ₂	Hard Wire	208/240/480V, 3-phase, minimum 20 Amp circuit required
Vacuum Pump- Water	W ₂	½" NPT	45 psig dynamic min, 80 psig static max, ¾"-1" NPT, 12 GPM capacity, with shut off valve and union ¹²

12) W₁ and W₂ cold water connections can be from a single source for a combined 12GPM capacity. Water quality must comply with the General Vacuum Device & Quench specification in Table 9. Backflow preventer not provided by CSS.

Table 5: Optional Electric Steam Generator

Name	Symbol	Connection on Sterilizer	MEP Requirements ¹⁴
Power Supply	E ₃	Hard Wire	Available in 208/240/380/480V, 3-phase, see Table 7 for Amp Draw
Generator Water Feed	W ₃	½" NPT	45 psig dynamic min, 80 psig static max, ¾"-1" NPT, 5 GPM capacity, with shut off valve and union ¹³
Manual Generator Drain	D ₂	½" NPT	Route to facility drain

13) Generator water feed must comply with the Generator Water Feed specification in Table 9. Backflow preventer not provided by CSS.

Table 6: Optional Chilled Water (WaterEco Plus and Vac Plus Units Only)

Name	Symbol	Connection on Sterilizer	MEP Requirements ¹⁴
Chilled Water Feed	W ₄	1" NPT	20 psi dynamic min, 35°F-50°F max temperature, 10 GPM capacity
Chilled Water Return	W ₅	1" NPT	-5 psi drop on return side, +15°F max rise

14) For a more detailed list of MEP requirements and specifications see "Autoclave Installation and Utility Overview" document #92006-01.

Table 7: Power and Steam Usage¹⁵

Power and Steam Usage			Electrically Heated					Steam Heated		
Model	Chamber Dimensions (w x h x f-b)	Air Removal Method	Generator Size (KW)	Generator Current (amps) ¹⁶				Steam Consumption		
				208V	240V	380V	480V	Peak (lb/hr)	Per Cycle (lb/cycle)	Idle (lb/hr)
3AV	20" X 20" X 38" 50.8 X 50.8 X 96.5 cm	Gravity	25	69	60	37	30	180	20	7
		Vacuum	25	69	60	37	30	180	35	7
26AV	26" x 26" x 39" 66 x 66 x 99 cm	Gravity	25	69	60	37	30	180	35	9
		Vacuum	30	83	108	46	36	180	55	9
26BV	26" x 26" x 49" 66 x 66 x 124.5 cm	Gravity	30	83	108	46	36	180	40	9
		Vacuum	45	125	108	68	54	180	70	9
26CV	26" x 26" x 67" 66 x 66 x 170.2 cm	Gravity	30	83	108	46	36	180	45	10
		Vacuum	45	125	108	68	54	180	75	10

15) Assuming 30 Minute sterilizing time at 250°F (121°C) and 5 minute drying time.

16) Nominal current drawn by a 3-phase generator. Local codes and regulations may affect breaker size. Single phase available if required.

Table 8: Water Consumption (Per Chamber)¹⁷

Model	Chamber Dimensions (w x h x f-b)	Air Removal Method	Water Consumption							
			Cold Water					Hot/Treated Water		
			Peak (gpm)	Per Cycle (gal/cycle)	Per Cycle With WaterEco™ Basic (gal/cycle)	Idle (gph)	Idle With WaterEco™ Basic (gph)	Peak (gpm)	Per Cycle (gal/cycle)	Idle (gph)
3AV	20" X 20" X 38" 50.8 X 50.8 X 96.5 cm	Gravity	6	58	46	9	1	1	3	1
		Ejector	6	93	87	9	1	1	4	1
		Vac Pump	6	34	27	9	1	1	4	1
26AV	26" x 26" x 39" 66 x 66 x 99 cm	Gravity	6	69	48	10	1	1	4	1
		Ejector	6	116	104	10	1	1	7	1
		Vac Pump	6	50	38	10	1	1	7	1
26BV	26" x 26" x 49" 66 x 66 x 124.5 cm	Gravity	6	75	49	10	1	1	5	1
		Ejector	6	130	115	10	1	1	9	1
		Vac Pump	6	60	45	10	1	1	9	1
26CV	26" x 26" x 67" 66 x 66 x 170.2 cm	Gravity	6	87	50	11	1	1	6	1
		Ejector	6	154	134	11	1	1	9	1
		Vac Pump	6	77	57	11	1	1	9	1

17) Assuming 30 minute sterilizing time at 250°F (121°C) and 5 minute drying time.

Table 9: Nominal Water Quality Requirements

Characteristic	Carbon Steel Steam Generators ¹⁸		General Vacuum Device & Quench	
	Recommended Condition	Maximum Condition	Recommended Condition	Maximum Condition
Temperature [°F (°C)]	As Supplied	140 (60)	40-60 (4-16)	70 (21)
Total Hardness (mg/L)	17	85	10-85	171
Alkalinity (mg/L)	50-180	350	50-180	350
Total Dissolved Solids (mg/L)	50-150	250	50-200	500
pH	7.5-8.5	7.5-9.0	6.8-7.5	6.5-9.0
Total Silica (mg/L)	0.1-1.0	2.5	0.1-1.0	2.5
Resistivity (Ω•cm)	2,000-6,000	26,000 ¹⁹	2,000-26,000	500,000

18) Stainless-steel generators require deionized water with resistivity ≥ 1MΩ•cm.

19) If water supplied is greater than 26,000 Ω•cm contact Consolidated for recommendation.

Table 10: Weight & Heat Loss Data

Model	Heat Source Options	Max. Operating Weight ²⁰	Peak Heat Loss (BTU/hr at 70°F [21°C])		
			Cabinet		Back of Wall
			To Room	Front of Wall	
3AV	Steam	1800 lbs	7000	2500	4500
	Electric	1975 lbs	8750	3300	5450
26AV	Steam	2700 lbs	11950	4300	7650
	Electric	2875 lbs	14200	5100	9100
26BV	Steam	2950 lbs	14390	4300	10090
	Electric	3125 lbs	16640	5100	11540
26CV	Steam	3450 lbs	18800	4300	14500
	Electric	3625 lbs	21050	5100	15950

20) Assuming chamber fully loaded with flasks filled 25% with water.



P.O. BOX 297 | 76 ASHFORD ST. | BOSTON, MA 02134-0003
P: 617.782.6072 | F: 617.787.5865 | INFO@CONSTERIL.COM | CONSTERIL.COM

Featuring Green Technology  for Energy Savings and Minimal Environmental Impact



©2017 Consolidated Machine Corporation V1 8/17