

SOUTHWEST ASSOCIATION OF TURNERS

26TH

ANNUAL SYMPOSIUM

Demonstration Handbook



TABLE OF CONTENTS

Welcome	3
Event Schedule	4
Symposium Floor Plan	5
Friday Rotation	7
Saturday Rotation.....	9
Sunday Rotation.....	11
Family Programs	12
Women in Turning.....	12
Beads of Courage	12
Executive Committee Members	13
Supporting Chapters	16
About the Artists.....	17
List of Demonstrations	27
Surface Carving w/Sandblaster.....	29
Light & Shadow - Photographing Wood Objects	31
Revelations in Hollowing	35
Sunburst Platter.....	35
Vessels of Illusion - Hollow Form, Carving & Wood Bending.....	35
Between Centers Pens & Other Applications.....	43
Turning Old & Antique Wood Pulleys	47
Hawaiian Calabash Bowl.....	51
Natural Edge Nested Sets.....	53
Sunny-side Up Egg on a Platter	55
Curves in All the Right Places: <i>Designing Attractive Forms</i>	57
Illusions - Unique Decorative Four Center Turning	61
Traditional Kaleidoscopes	63
Make a Button Cylinder Pendant.....	67
The Airbrush Demystified.....	73
Airbrush Art - How to Successfully Transfer Images.....	73
Wood Choices for Woodturning Projects	79
Snowflakes & Beyond - Doing More with Spindles	85
Natural Edge Bowl from a Crotch.....	89
Sand Carving - Design & Create Images	95
Turning Triangles - Unique Multi-Center Turning	97
My Friend the Skew.....	101
Bangle, Pendant, and Earrings	107
The Fine Art of Finials	109
Skew Skills - Making the Cuts	113
Square Rimmed Bowls.....	115
Use of Ground Plastic Beads as Enhancements	117
Crush Grind Pepper Mills	123
The Science & Art of Stabilizing Wood & Other Porous Materials	127
How to Turn Natural Edge End Grain Mesquite Bowls	131
Making Mini Vessels & Carving Texture.....	133
Pyrography Tips & Tricks	133

2017 SWAT VENDORS

2TreeBoyz	James Kessler Wood
AAW	John Jordan Woodturning
Airbrush On Wood	Kallenshaan Woods
Alan Lacer Tools	Lyle Jamieson
Amalgam Mutt Blanks	Nave's Sawmill
AZ Carbide	Niles Bottle Stoppers
Best Wood Tool	Oneway Manufacturing
Big Monk Lumber	Peach Tree Wood Working Supply
Buffalo Woodturning Products	Rising 3B Wood
Canyon Studios	Robust Lathe and Tool
Carter and Son Tool	Starbond CPH
Century Tree Turnings	Ten Second Studio
Chef Ware & Turning Tools	Thompson Lathe Tools
Chucks Plus	Trend Routing
Cindy Drozda Tools	Turn Texas Wood Works
Conestoga	Turning Wood
Craft Supplies	Vinces Wood N Wonders
Design In Wood	Wildwood Design
Doug Baldwin Photography	Woodpeckers Inc.
Easy Wood Tools	Wood Turners Wonders
Flute Master	Wood Turning Tool Store
Frugal Vacuum Chuck	Wood Workers Emporium
Heritage Wood School	Wood World of Texas
Hill Country Wood	Woodturners Pro
J T Turning Tools	Woodturning with Tim Yoder
James Johnson Bowls	

Support SWAT Vendors

Many come from halfway across the country to bring you their products. Show them our Southwest Hospitality

WELCOME
to the
26TH ANNIVERSARY
of the
**SouthWest Association of Turners
Annual Symposium**

This is the 26th Anniversary of Southwest Association of Turners. On behalf of the Board of Directors from each of our 27 member clubs, the Executive Committee, the Committee Chairs and all of the many volunteers who work to make this the best Woodturning Symposium in existence, I would like to thank you for your support of the SWAT Symposium for the past 26 years. Hopefully, this will be a great learning experience to all attending.

There are approximately 51 different vendors who will offer tools and accessories, lathes and lathe accessories, woods of all species, finishing, dyeing and enhancement items, sanding materials, new tools and turning items, stabilizing equipment, etc. Once you have purchased that new tool, there will be a Sharpening Booth where you can put the edge on the tool that you desire and then you can go to the Hands On or Pen Turning Booth and try out the new tool(s).

We will have the famous and ever popular Two-For-One Raffle where there are opportunities to win beautiful art pieces and tools, lathes (a Robust American Beauty, and 3 Jet 1221VS). The 2 for 1 Raffle tickets will first be drawn on Saturday night after the banquet. This will be for art pieces donated by peer selected turners, as well as, an Arrowmont tuition for a week, and a AAW membership. All tickets drawn Saturday night are returned to the bin earning the Two-for-One name. The second half of the 2 for 1 Raffle will occur after lunch on Sunday. This second drawing will be for tools, wood, turning accessories donated from our vendors, with the penultimate prizes being the 3 Jet mini lathes and the ultimate prize being the Robust Black Beauty, which will then conclude the festivities of the 2017 Symposium.

Our Art Gallery is second to none. It is the largest of its kind in the U.S.A. and is such a special area that we dedicate an entire room for art pieces that are displayed by turners that are attending the Symposium. Any turner has the availability to display (some are for sale) up to ten items in our ART GALLERY. Also, a section in the Art Gallery will be dedicated to the Beads of Courage exhibit of boxes that will be donated to various hospitals to be given to youngsters that are struggling through various treatments for serious life threatening diseases. You can also check the SWAT website for more information and a link to the Beads of Courage website.

For a very small registration fee of \$140 you will be exposed to 6 internationally known Lead Demonstrators (Trent Bosch, Andy Cole, James Duxbury, Al Hockenbery, Eric Lofstrom, Molly Winton) and 15 Regional demonstrators, which create 54 turning rotations. You will receive an electronically generated or printed handbook, access to a tremendous Art Gallery, Demonstration by Trent Bosch & Al Hockenbery on Friday night, various vendors and two separate drawings for art and tool items. Women in Turning will gather during lunch on Friday, and World of Woodturning meets after lunch on Saturday.

None of the above would be possible without your participation and the efforts of many volunteers that work hard and long to bring the SWAT Symposium to you each year. **So welcome and may you have an outstanding experience at the 26th Anniversary of the SouthWest Association of Turners Symposium.**

Stormy Boudreaux
President, SouthWest Association of Turners
Email: sbdx71@gmail.com

EVENT SCHEDULE

Thursday

7:00 AM Doors Open for Vendors
(Tables Not Available Until Unloading Complete)
Registration Set-up (Staff Only)

3:00 PM Registration & Logo Ware Sales Open
(Drawing Ticket Sales @ Window #4)

3:00 - 6:00 PM Gallery Open for Check-in

5:30 PM Vendor Unloading Closes

5:30 - 7:00 PM Meet & Greet in Brazos South
(Introduction of Demonstrators + Cash Bar)

6:00 PM Registration & Logo Ware Sales Close

Friday

7:30 AM Gallery Opens

8:00 AM Registration & Sales Open

9:00 AM Opening Ceremonies in Chisholm Hall

10:30 AM Demonstration Rotations Begin

12:00 - 1:30PM Women in Turning

5:00 PM Gallery Closes

6:00 - 7:30 PM Friday Dinner (Joe Blane Catering)
Note: Tickets must be purchased in Advance

7:30 - 9:00 PM Entertainment Extravaganza in Brazos North & South Rooms
(See Rotation Schedule)

Saturday

7:30 AM Gallery Opens

8:00 AM Registration & Sales Open
Demonstration Rotations Begin

1:00 - 1:30 PM World of Woodturners (WOW) Gathering

5:00 PM Gallery Closes

6:00 - 8:00 PM Cash Bar

6:30 - 7:30 PM Banquet Dinner

7:30 - 9:00 PM 2-for-1 Drawing

Sunday

7:30 AM Gallery Opens

8:00 AM Demonstration Rotations Begin

11:00 AM Gallery Closes for Disassembly
(Artist Pick-up Turnings)

12:00 PM Demonstration Rotations for 2017 End
Lunch
Tool Drawing

Note: Vendor Checkout Begins Approximately 15 minutes after Tool Drawing finishes

WACO CONVENTION CENTER

Upper Level

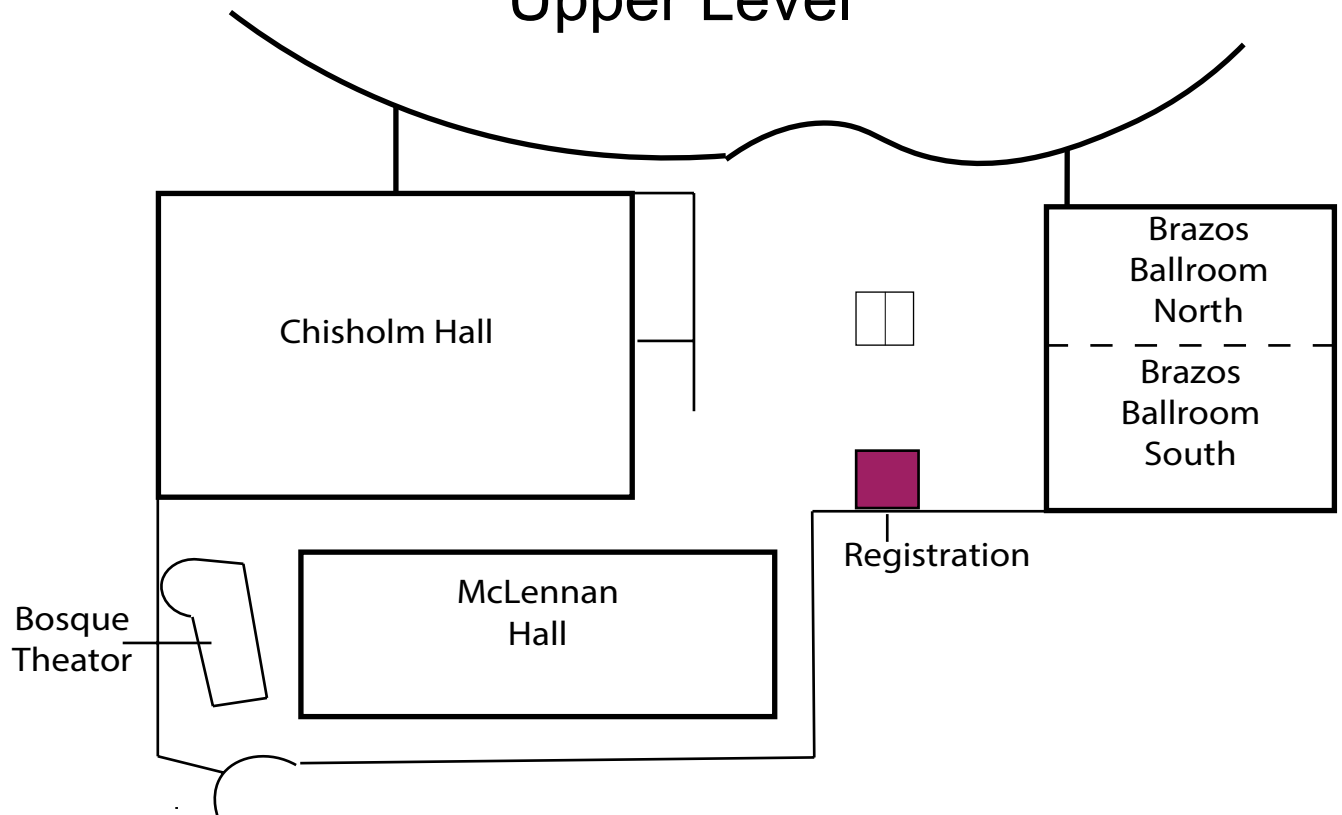

Lower Level

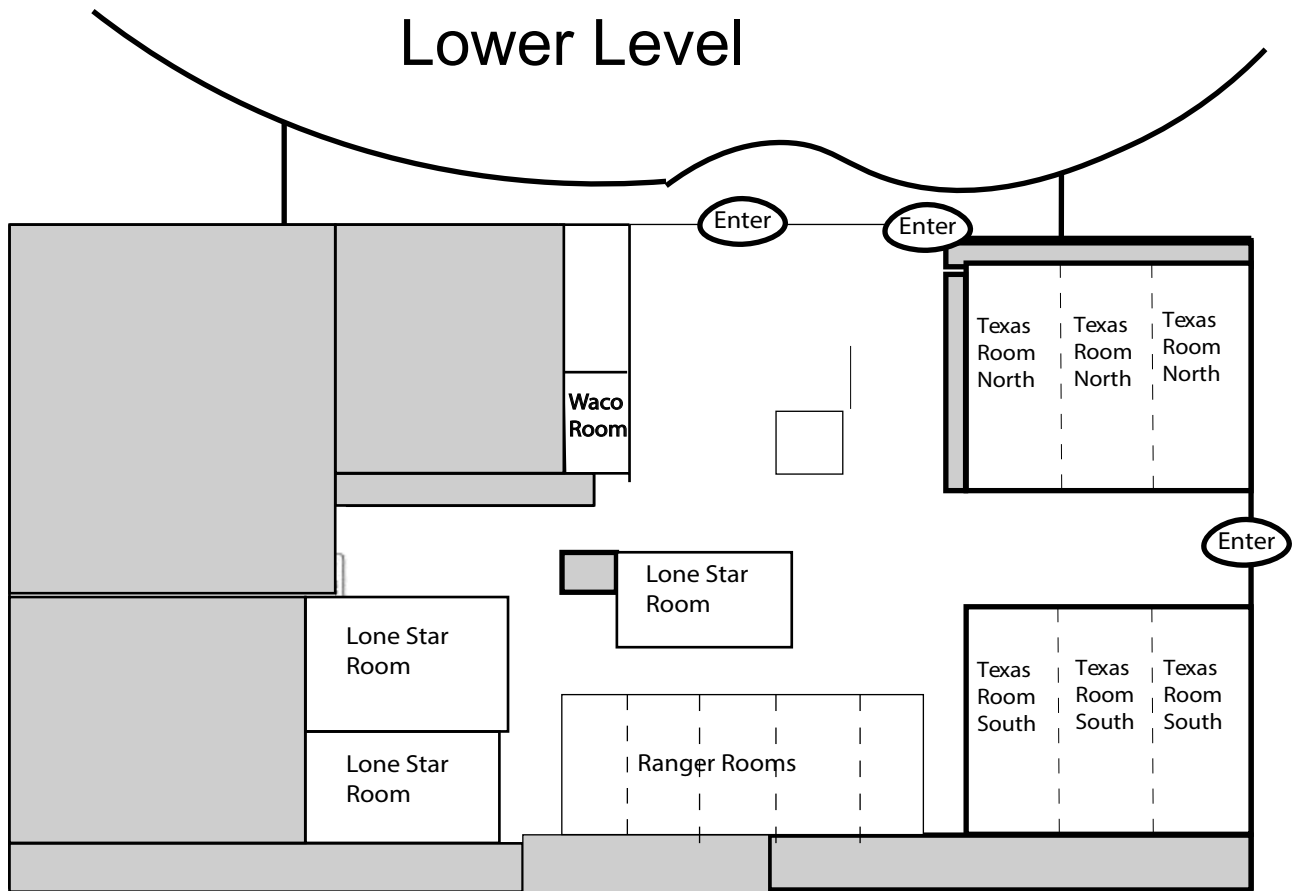

2017 Rotation Schedule

ROOM	TEXAS NORTH POWERMATIC	BRAZOS NORTH VICMARC	TEXAS SOUTH 116/117 POWERMATIC	BRAZOS SOUTH ROBUST	TEXAS SOUTH 118 POWERMATIC	RANGER POWERMATIC
SPONSOR	CTWA	HUNT COUNTY	GCWA	WNT	HILL COUNTY	DAW
Friday - August 25, 2017						
9:00-10:00	Opening Ceremonies - Chisholm Hall					
10:30 - 12:00	LINDA FERBER Button Cylinder Pendant	TRENT BOSCH Revelations in Hollowing	ANDY COLE Natural Edge Nested Sets	JIM TANKSLEY Natural Edge End Grain Mesquite Bowls	LES CASTELL Turning Old & Antique Wood Pulleys	MOLLY WINTON Pyrography Tips & Tricks
12:00 - 1:30	WOMEN IN TURNING GATHERING LUNCH					
1:30 - 3:00	JAMES DUXBURY Traditional Kaleidoscopes	GEORGE FREEMAN Wood Choices for Turning	JEANNE DOUPHRADE Curves in all the Right Places	ERIC LOFSTROM Skew Skills - Making the Cuts	AL HOCKENBERY Sand Carving - Design & Create Images	ROBERT HENRICKSON Doing More with Spindles - Snowflakes
3:00 - 4:00	Break					
4:00 - 5:30	CURTIS SEEBECK Science & Art of Stabilizing Wood	JIM BOB BURGOON Between Centers - Pens	ANDY COLE Hawaiian Calabash Bowl	JANICE LEVI Fine Art of Finales	SALLY AULT Surface Carving with a Sandblaster	MOLLY WINTON Making Mini Vessels & Carving Textures
6:00 - 7:30	Special Pre-Demo Dinner -- Chisholm Hall					
*****Special Demonstration by Trent Bosch & Al Hockenbery*****						
7:30 - 9:00		DEMO Trent Bosch		DEMO Al Hockenbery		

2017 Rotation Schedule

ROOM	TEXAS NORTH	BRAZOS NORTH	TEXAS SOUTH	BRAZOS SOUTH	TEXAS SOUTH 118	RANGER
SPONSOR	CTWA	HUNT COUNTY	GCWA	WNT	HILL COUNTY	DAW
Saturday - August 26, 2017						
8:00 - 9:30	JAMES DUXBURY Illusions - Unique Decorative Four Center Turning	JOE FLEMING Airbrush Demystified: Getting Started in Airbrushing	JOSH REID Crush Grind Pepper Mills	ERIC LOFSTROM Square Rimmed Bowls	SALLY AULT Surface Carving with a Sandblaster	MOLLY WINTON Pyrography Tips & Tricks
9:30 - 10:30	Break					
10:30 - 12:00	ALAN LACER My Friend the Skew	TRENT BOSCH Revelations in Hollowing	JEANNE DOUPHRADE Curves in all the Right Places	JANICE LEVI Bangle, Pendant, & Earrings	AL HOCKENBERY Sand Carving - Design & Create Images	DAVID MUELLER Ground Plastic Beads as Enhancements
12:00 - 1:30	Lunch					
1:00 - 1:30 World of Woodturners (WOW) Gathering						
1:30 - 3:00	CURTIS SEEBECK Science & Art of Stabilizing Wood	GEORGE FREEMAN Wood Choices for Turning	ANDY COLE Sunny-side Up Egg on a Platter	ERIC LOFSTROM Square Rimmed Bowls	DOUG BALDWIN Light & Shadow - Photographing Wood Objects	LINDA FERBER Button Cylinder Pendant
3:00 - 4:00	Break					
Executive Committee Meeting - Brazos South Demonstration Room						
4:00 - 5:30	JAMES DUXBURY Traditional Kaleidoscopes	TRENT BOSCH Sunburst Platter	JOSH REID Crush Grind Pepper Mills	JIM TANKSLEY Natural Edge End Grain Mesquite Bowls	AL HOCKENBERY Natural Edge Bowl from a Crotch	DAVID MUELLER Ground Plastic Beads as Enhancements
6:00 - 8:00	Cash Bar					
6:30 - 7:30	Banquet Dinner					
7:30 - 9:00	2 - For - 1 Drawing					

2017 Rotation Schedule

ROOM	TEXAS NORTH	BRAZOS NORTH	TEXAS SOUTH	BRAZOS SOUTH	TEXAS SOUTH 118	RANGER
SPONSOR	CTWA	HUNT COUNTY	GCWA	WNT	HILL COUNTY	DAW
Sunday - August 27, 2017						
8:00 - 9:30	JOE FLEMING Transferring Images for Airbrushing	ROBERT HENRICKSON Doing More with Spindles - Snowflakes	ANDY COLE Natural Edge Nested sets	ERIC LOFSTROM Skew Skills - Making the Cuts	AL HOCKENBERY Turning Triangles - Unique Multi-Center Turning	MOLLY WINTON Making Mini Vessels & Carving Texture
9:30 - 10:30	Break					
10:30 - 12:00	JAMES DUXBURY Illusions - Unique Decorative Four Center Turning	TRENT BOSCH Vessels of Illusion - Hollow Form, Carving & Wood Bending	JIM BOB BURGON Between Center Pens	DOUG BALDWIN Light & Shadow - Photographing Wood Objects	LES CASTEEL Turning Old & Antique Wood Pulleys	ALAN LACER My Friend the Skew
12:00 - 1:30	Lunch and Tool Drawings					

Note: Schedule subject to change as needed. Changes will be posted to the website as soon as they are available!

Travel Safe & Have a Safe and Productive Turning Year.....

FAMILY PROGRAMS

This year's selection of programs, demonstrations and trips is designed to provide fun activities for the family members of the SWAT attendees. We will have a full day of Genealogy on Friday (some refresher classes, some new topics) and a variety of crafting classes and demonstrations on all three days. We will have our annual favorites; Zentangle, Fused Glass Jewelry, the Book Club Discussion, Spinning and Dyeing Demonstration and our Saturday morning "Share Time". We also have some classes repeating from last year as well as brand new topics! If you'd like to escape, check out the two trips; one on Friday to visit local museums (for art and culture enthusiasts) and one on Saturday to enjoy the Homestead Heritage Village (and to eat at the Cafe Homestead).

This year, our main room will be available as our "Community Store - to Shop, Sit, and Socialize"; bring your favorite unfinished projects to work on or if finished, to share or to sell! Come ready to spend time with friends! Check the event schedule and register early! All fee-based activities will require payment to the instructor (or trip captain) with cash only.

WOMEN IN TURNING

The Southwest Association of Turners Symposium 2015 hosted its first *Women in Turning* gathering. *Women in Turning* is a virtual chapter of the American Association of Woodturners, that had its start at the 2014 AAW Symposium in Phoenix, AZ when Betty Scarpino organized a meeting of women to see if there was interest in forming a group focused on the support of women woodturners.

If you are attending the SWAT Symposium this year, please plan to join our meeting. The time and place will be posted throughout the Convention Center and on the Rotation Schedule.

BEADS OF COURAGE



The SWAT Symposium took on the Beads of Courage program in 2010 inspired by Craig Fyock, owner of Wood World, Texas. Each year the contributions for the Beads of Courage by SWAT attendees and support of our vendors has exceeded the previous year, with 149 boxes in 2014. If you are not familiar with the program, visit the Beads of Courage web site <http://www.beadsofcourage.org/pages/about.htm/>, it is really a heart-warming experience.

If you are considering turning or making a box for Beads of Courage, the guidelines can be found on their website at <http://www.beadsofcourage.org/pages/woodworkers.htm/>.

Note: Beads-of-Courage entries are not judged.

EXECUTIVE COMMITTEE MEMBERS

PRESIDENT, STORMY BOUDREAU

My father was a carpenter contractor and I was always holding the end of a board that he was sawing or he had me close but out of the way, bending nails, pounding them into a chunk of 2x4 that he gave me to keep me occupied. He always built our homes, selling them as they were finished, and then building another, so on weekends I helped. During high school and college summers, he taught me the intricacies of finish carpentry. However when I graduated from college and joined the US Air Force as a pilot, my apprenticeship ended. Most military bases at the time had a DIY shop where I built really pitiful tables and other utility works of non-art. I did some carving and pyrography on going-away presents for members of my squadron, ultimately making a lot of picture frames. Then, when I retired from USAF, I opened an art gallery and picture framing business, but that wasn't viable. I finally found a real job with Lockheed, first in Palmdale CA and then in Fort Worth TX. In summer of 2003, while visiting the local Woodcraft store, I was invited to a Saturday demo at the Woodturners of North Texas (WNT) facility. Dick Sing was teaching how to turn an egg. Never having been near a lathe before, I wasn't ready for that, so Dick showed me some of the basics of woodturning and had me practice some spindle work. I was hooked. I bought a used Jet mini-lathe, and before I knew it, I was President of WNT. Seems like I blinked and suddenly I was President of SWAT. The people you meet and the things you can learn at the SWAT Symposium are priceless!



VICE PRESIDENT, CLYDE LITTLE

After 37 years experience in the electronics/computer world (mainly IBM), I decided to take up woodworking. Built a 24 x 60 shop and equipped it with woodworking tools, including a lathe that set idle for a year-didn't know what to do with it. I went to a Central Texas Woodturning meeting, where Stacey Hager was presenting. It turned out that Stacey and I had run around together at UT in the mid 60's and had not seen each other until the meeting. I subsequently became active in CTWA, learning woodturning from the best and eventually became president. I now have three lathes and lots of wood. I enjoy turning mesquite the most. Pat (my wife who is a past president) and I sponsor/host many classes in our shop, to include beginner's classes and national turners every year. It is a pleasure to be involved in a discipline with so many people that care about others and unselfishly share their knowledge. Because of that, I hope to help SWAT to continue to be the best symposium in the world, educating and sharing. I consider it an honor to be involved in such a community.



2ND VICE PRESIDENT, GORDON GRAVES

I was first introduced to a wood lathe in 1960, in 7th Grade wood Class. Mr. McDonald, my instructor, helped me attach a face plate to a chunk of maple. Took me three weeks of class to turn my Dad an ashtray. I still have that ashtray. After high school and college I started farming, forty-two years later I retired. During that 42 years I put together a good woodworking shop. Farming was always my first love, but woodworking came a close second. I bought my first lathe in 1992, a small Craftsman bowl lathe. In 2013 I decided I needed a bigger lathe, but during the hunt I found something much more valuable, The Southplains Woodturners



Club. Mr. Glenn Williamson, one of the founding fathers of our club, sold me a lathe and sold me on the club. I joined the club shortly after and have attended many classes, beginners and intermediate. I am now helping to teach these same classes as well as serving as the club treasurer. I attended my first SWAT symposium in August of 2016 and was amazed at the number of people who were interested in woodturning. Everyone I met was friendly and helpful. I am looking forward to helping to carry on the proud tradition of SWAT.

SECRETARY, BETTY HAGER

Woodturning is not my primary hobby, but being married to Stacey Hager; I have had some quality lessons and have turned several art objects. When I turned these I was using a Delta Midi lathe or Stacey's 2436 One Way. I have attended this woodturning symposium since it was called TTT (Texas Turn or Two) and was held at the Maricopa Camp Ground. I remember the first time we attended a TTT symposium. The Maricopa location offered a few motel rooms and plenty of camp sites. There was a large barn where two demonstrations were staged and two smaller buildings for the other two demos; four choices at each rotation. The vendors were in tents! There were two to three tables where turners could display their work



called the "Instant Gallery!" These early get-togethers were held in October. When the weather was great it was a perfect time of year...but we had two cold rainy years in a row. Something had to change. So we tried other locations – San Angelo, Temple, Wichita Falls...finally finding our current venue at Waco. Stacey and I were representatives from our Club (Central Texas Woodturners) when we transitioned from TTT to Southwest Association of Turners (SWAT). In 2008, I served as secretary to Steven Gottlieb when he was President of SWAT. I wrote a manual for the organization to provide some continuity from one year to the next. I have attended AAW and the Utah Woodturning Symposium and they are both wonderful, but what impressed me early on about our gathering was the spirit of friendship and willingness to share. The name tags at TTT always had your first name in large type...for everyone, turners and presenters. So everyone was on a first name basis. I watched David Ellsworth shoot long streamers of wood from his hollowing project, targeting friends in the audience. Rude Osolnik, gave me my first tuning lesson in a tent at the Powermatic booth. We have come a long way from those days, but I believe in this organization. Whether you are a beginning turner or an advanced artist, you will meet some great people at this Symposium and every time you attend you will learn something that will improve your skills.

TREASURER, DAVE MARSHALL

Raised in a small cabin on the plains of Kansas, I started my woodworking and woodturning career early in life. After building my first, small lathe, I began my woodturning career by selling hand-turned toothpicks to local farmers and businessmen. My skill set grew tremendously during this period which culminated in my ability to use a scraper to turn almost any product on the lathe. When I was thirteen, I read with lust about turner David Ellsworth in in an old black and white edition of Fine Woodworking. That article vaulted me to turn (scrape) my first box and lid. A beauty of a specimen in black walnut. Form and function – perfect. The bottom lacking just somewhat as not being completely flat and bearing the hallmark of three screw holes that attached the faceplate. Still stunning today.



Thirteen was the age a young student began his first year in Industrial Arts class in junior high school. After sweet-talking my Industrial Arts teacher, Mr. Anderson, he allowed me to come to shop before classes started for the day and turn all I wanted. He showed me the very basics of

some of the limited tools we had available for turning. For some reason I don't ever recall a lesson in sharpening these tools though... that probably explains my expertise with the scraper. I turned my heart out that year; sock darns, miniature baseball bats, candlesticks, miniature baseball bats, boxes, small plates, miniature baseball bats to name a few. Something happened. I think life, girls, schooling, college, my masterplan to escape Kansas tapered my turning time. Now don't get me wrong, I tried to design, woodwork and woodturn as much as possible. I've always loved the design and then build and then re-design cycle of creation. Maybe that's why I became an Aerospace engineer. After graduation and landing in sunny Burbank, California, I got my first paycheck. I bought my first Shopsmith for my single-car garage/shop. I was on my way! Years later, and hundreds of projects later, we ending up in panther-sleepy Fort Worth. After starting a family, I began to look for a woodworking club to join, similar to ones I belonged to in California and Georgia. Not finding anything close by in the Metroplex, I ran across a magazine article featuring Devore Burc and its mentioning of a bunch of ragtags called the Woodturners of North Texas. Whoa... they met only three miles from my home! Their next meeting, I snuck in and grabbed a seat and was blown away by the demo. I was hooked again. I know that this is fascinating as all get-out, but long-story short, I joined that ragtag bunch and haven't looked back. After a while, I was president of the Woodturners of North Texas. The glamour and prestige went to my head and I ruled the Club with an iron fist for four years. That group of ragtags became a lean, mean turning machine, I say. As a Club member, I became familiar with the South West Association of Turners and attended my first SWAT symposium. Blown away, again! Unbelievable talent...and some of the other turners weren't that bad either. I've been Treasurer of SWAT for a few years now and can almost make the budget numbers add up - between turning projects. The remainder of my free time is spent....wait, I have no free time outside of SWAT. Other activities I do between SWAT projects are spending quality time with my wife, devotion to my new career in the Oil and Gas business, I'm also Treasurer of a professional organization (North Texas Measurement Association), eating, sleeping... well, you get the drift. I am truly honored to be associated with SWAT and every year look forward to the unbelievable talent and skill that you all bring to Waco! Onward to our 26th anniversary!

PAST PRESIDENT, CLINTON "BUDDY" COMPTON

Introduced to woodturning by Larry Roberts in 2002, I became enamored with the craft of turning wood and creating a usable piece of art. (It really wasn't art at that time). I started this wood turning journey on a Shopsmith. Graduated to a Powermatic 3520B in 2002 and obtained a Robust (American Beauty) in 2006. I spent 8 to 10 hours a day in the shop (and visits to Larry Roberts shop and this relationship has continued through the years) turning objects to hone the skills that I was developing. Numerous books, videos, observing demos, along with annual visits to SWAT have been a large part of my evolvment and are the reason that I have tried many different turning ideas that were far more advanced than my talent level. The time spent in this endeavor has been greatly rewarding and brought many new friendships to my life. I joined AAW, Comanche Trail Woodturners and South Plains Woodturners. Each of these has given me an opportunity to watch and learn from very experienced turners who are willing to help and assist in all areas of the woodturning journey that I have been on.



I really enjoy SWAT and the value I receive from attending the Annual Symposium, and I look forward to serving SWAT on the Executive Committee and keeping the tradition going.

SUPPORTING CHAPTERS



Abbr	Chapter	Area
AW	Alamo Woodturners	San Antonio, TX
ALT	Ark-La-Tex Woodturners traderdon55@hotmail.com	Texarkana, TX
BW	Bayou Woodturners	New Orlenas, LA
BLT	Borderline Woodturners cwieters@elp.rr.com	El Paso, TX
BVW	Brazos Valley Woodturners	Waco, TX
CAW	Central Arkansas Woodturners	Hot Springs, AR
COW	Central Oklahoma Woodturners Assn	Oklahoma, OK
CTWA	Central Texas Woodturners	Austin, TX
CBW	Coastal Bend Woodturners	Corpus Christi, TX
CTW	Comanche Trail Woodturners	Midland, TX
CVW	Concho Valley Woodturners	San Angelo, TX
DAW	Dallas Area Woodturners	Dallas, TX
DSW	Diamond State Woodturners	Jacksonville, AR
ETW	East Texas Woodturners Association	Tyler, TX
GTW	Golden Triangle Woodturners	Denton, TX
GCW	Gulf Coast Woodturners Association	Houston, TX
HCT	Hill Country Turners	Kerrville, TX
HCW	Hunt County Woodturners, Inc.	Greenville, TX
LWT	Lone Star Woodturners	Spring, TX
NEOWTA	Northeastern Oklahoma Woodturners Assn	Tulsa, OK
NWOW	Northwest Oklahoma Woodturners	Enid, OK
PAT	Panhandle Area Turners Society celsea@yahoo.com	Amarillo, TX
SEOW	Southeast Oklahoma Woodturners engelwilson@fullnet.net	Idabel-Broken Bow, OK
SPW	South Plains Woodturners	Lubbock, TX
STW	South Texas Woodturners	Victoria, TX
WFW	Wichita Falls Woodturners handlebarsturner@aol.com	Wichita Falls, TX
WNT	Woodturners of North Texas	Ft. Worth, TX

ABOUT THE ARTISTS

SALLY AULT

Website: sallyault.com

Born and raised in San Diego, California, Sally graduated with a BA degree in Art with a Crafts emphasis from San Diego State. Her work there focused on Weaving, Jewelry Design and Ceramics. During a furniture class, she discovered woodturning. After a break of a number of years, she resumed woodturning in 2004.

She enjoys all types of wood turning but her current focus is on lidded containers including the sea Urchin series, open bowls, embellished pieces and jewelry.

Her work is shown in the Dunn Gallery in Hawaii, Hawaii, The Real Mother Goose in Portland, Oregon, The gift shop at Anderson Ranch Arts Center in Snowmass, Colorado, at The A Store in Albuquerque, New Mexico and in the gallery at Studio 38 in Spanish Village Art Center in Balboa Park, San Diego.

Sally has won several prizes at the Design in Wood Show at the Del Mar Fair. In 2010, she was awarded a "Best in Class" ribbon for a Myrtle Wood Platter, and in 2011, a Maple Hollow Vessel was awarded the San Diego Woodturners Special Award. Her Sea Urchin Box won a special purchase award at the 2012 Small Image Show at Spanish Village. Her Box Elder Burl and Coral piece won an award at the 2014 Small Image Show.

She was a demonstrator at the 2012 Utah Woodturning Symposium in Orem, Utah, the 2012 Wisconsin woodturning Symposium and at a number of woodturning clubs across the country. In fall of 2013 Sally was accepted for a 10 week Artist in Residency program at Anderson Ranch Arts Center.

Sally is a member of the San Diego Woodturners Association, American Association of Woodturners, Point Loma Artists Association and Spanish Village Art Center in San Diego.

DOUG BALDWIN

Email: info@dougbaldwinphoto.com

Website: dougbaldwinphoto.com

Doug was given his first 35mm camera, an Exakta 500, upon graduation from the 8th grade. Two years later he received his first Nikon. He graduated from the Art Center College of Design in 1979 with his BFA in Photography.

For 35 years Doug Baldwin Photography has offered creative solutions for a range of clients for individual artists to corporate and advertising clients nationwide. His technical expertise includes all camera formats: digital SLR, high resolution digital scanning back 35mm, 2-1/4 and 4x5.

Doug has extensive experience in Product Color Matching, Photo Illustration, Digital Imaging, Digital Retouching & Special Effects.

Doug shoots in the studio as well as on location, and produces projects ranging from manufacturing and marketing to health and high tech.

TRENT BOSCH

Trent Bosch Studios Inc.
10520 North County Rd 17
Fort Collins, Colorado 80524
Phone: 970 218-6453
Email: info@trentbosch.com
trent@trentbosch.com
Website: trentbosch.com

Working with wood is part of my everyday life. It is my connection to the earth and the environment in which I live. While pursuing my Bachelor of Fine Arts degree in photography and sculpture, I became interested in the art of woodturning.

My philosophy has always been to work in harmony with our environment and not to destroy something in order to create something. In all my art, I use only recycled and easily sustainable woods. Being conscious of this has allowed me to work with the subtle beauty and dimension this discarded wood possesses.

My intent as an artist is to express my feelings about nature, my family and natural processes. I work in series or bodies of work, which allows me to explore these issues in depth. Throughout the creative process, I am continually reminded that I have not and will not ever be content. I will continue to create and strive for that body of work that has yet to be conceived.

JIM BOB BURGOON

Facebook: [jimbob.burgoon](https://www.facebook.com/jimbob.burgoon)

Jim Bob is a graduate of West Texas State University with a degree in Industrial Education. He oversaw the Woodworking class at Levelland High School from 1983 to 1998. He then served the Lubbock Independent School District, teaching Technology Education at two middle schools until his retirement in 2011. During his teaching tenure, numerous students competed in the Technology Students Association's regional and state project competitions. He was named Regional Outstanding Teacher by the South Plains Industrial Teacher Association three times during his teaching career.

Burgoon joined the South Plains Woodturners upon its inception in 2006. Since then he has served in the capacities of club librarian, Treasurer, 1st Vice-President, President, and Past President. With his extensive background in woodworking, Jim Bob has demonstrated numerous times for his local club. He has also demonstrated for the Panhandle Area Turners Society (PATS) in Canyon, Mountain Top Turners in Ruidoso, New Mexico, Woodturners of North Texas in Fort Worth, Comanche Trail in Midland, and SWAT. Jim Bob is the lead teacher in the South Plains Woodturners beginner and intermediate classes held 6 times annually.

Since retirement in 2011, Jim Bob has opened a woodworking shop. He does a wide variety of woodworking activities from custom turning to flat work! His work can be viewed on Facebook by searching @jimbobburgoonwoodworks. Jim Bob annually turns commemorative baby rattles for Monterey Church of Christ's Family Commitment Sunday. He has lived in Lubbock since 1985. Burgoon is married, with two children.

LES CASTEEL

Email: lescasteel@gmail.com

Les Casteel was born and raised in Seminole County, Oklahoma. He began his college career in the field of design engineering. Later, in life he earned a degree in Computer Science. Les worked for several major American corporations and worked on projects where a working knowledge of ergonomics was needed. Attending a workshop with Sam Maloof in 1997 set him onto the path of leaving the corporate world and transitioning into building fine sculpted rockers.

Les learned the basics of woodworking while helping to build barns, gates, fences, and tree houses on his parent's farm when he was young. He has crafted toys, tables, clocks, cradles, beds, bookcases, bowls, entertainment centers, racks and now rockers and chairs.

Influenced by the German craftsmen of the Amana Colonies in Iowa has left a deep appreciation of fine, old world craftsmanship using cherry and walnut woods. Having the chance to work and learn at the Shaker villages of South Union near Bowling Green, Kentucky, gave Les a strong appreciation of Shaker furniture and life. It instilled an appreciation of the beauty of simplicity when applied to pieces of furniture. The simple lines and design of the sculpted rockers and other furniture produced therefore tend to be very "Shaker like". Finally, Les has received training and mentoring from several prestigious chair makers including the legendary Sam Maloof of California, Hal Taylor of Virginia, and Robert Hensarling of Texas.

Les is an award winning wood carver having held memberships in several woodcarving clubs and guilds as he lived in different areas of the country. He has studied under several accomplished woodcarvers including the legendary Harold Enlow as well as Gerald Sears, Branson's Peter Engler and others. Occasionally, Les will carve a full size carousel horse or rocking horse for a client. These rocking horses satisfy the urge to do things freehand and further express creativity through woodcarving. Les also produces woodturnings and has belonged to several turning clubs over the years. He is particularly fond of turning polychromatic-segmented turnings, especially bowls.

Les now spends the majority of his time crafting fine hardwood rocking chairs in his mountaintop workshop located near historic Harrison, Arkansas, 30 miles south of Branson, Mo. All skills must come into play in order to build a rocker of this type. Woodworking, woodcarving, sculpting, and wood turning skills are all needed to create these heirloom quality rocking chairs.

Artist Statement

The sculpted rocking chairs, music stands and tables, I build are heavily influenced by designs of Sam Maloof, Wendall Castle and George Nakishima. I choose to sculpt and assemble from native hardwoods. Much effort is given to the use of color and grain of each piece. The majority of my furniture is made of walnut. This however, does not blind me to the beauty of cherry's grain, the color of purple heart or the wonderful cream color of maple. The techniques used to build this furniture are tried and true. Intricate often hand tooled joinery is used to enhance both the strength and beauty of this furniture. Great importance is placed on the ergonomics of each piece so that although beautiful they are very human friendly.

Developing the intricate curves of such furniture often leave hundreds of pieces of precious hardwood that normally would go to waste. I've developed a use for this wood by designing and turning polychromatic segmented woodturnings. The hardwood is cut into small pieces, glued into rings, stacked together and turned on a lathe. These become vessels, bowls, platters and such whimsical pieces such as chess sets. This allows me to waste very little material and makes it much easier to justify the cutting of beautiful native hardwoods.

Awards & Acknowledgements

2004 Wonderful World Of Wood, Tulsa, OK (1st Place Furniture)

2107 SWAT

2004 Wonderful World Of Wood, Tulsa, OK (2nd Place Woodcarving)

2004 Wonderful World Of Wood, Tulsa, OK (3rd Place Wood Turning)

2010 Inclusion in "Arts & Artists Of The Ozarks", One of my woodturnings was included on the front cover.

ANDY COLE

Andy Cole

1534 Bertram St.

Honolulu, HI 96816

Phone: 808-778-7036 (cell)

Email: andycolewood@gmail.com

Website: andycolewoodturning.com

Throughout his life, the intricate beauty of wood grains and the amazing works of wood art have fascinated Andy. After learning the basics in woodturning about fifteen years ago through a class at the local Woodcraft store, he was hooked! What started as a hobby soon blossomed into a full time passion and profession.

Andy was soon introduced to the Honolulu Woodturners Club, a local chapter of the AAW, where he owes much of his success to the local members who coached and encouraged him in the early days of turning. The club has grown significantly over the years and Andy enjoys giving back by organizing and promoting a variety of turning events around the state. He founded and organized the Honolulu Symposium as a way of bringing a taste of the national symposiums to the locals who found it hard to travel thousands of miles for such an event. He finds much joy and satisfaction in helping others to learn the skills to transform pieces of firewood into heirloom works of art. Finding balance between time spent in the studio and energy focused on promoting turning is always a challenge.

While he enjoys many aspects of turning, producing natural edge bowls gives Andy the ability to integrate the organic beauty of wood into an aesthetically pleasing form. Not wanting to waste the inside of the vessel, he learned how to core multiple natural edge nested pieces from one piece of wood. Andy's nested set demonstrations are always very popular with turners who have attempted coring with varying degrees of success. He rejects the notion of being a master, but has learned many tips that he is eager to share with others.

JEANNE DOUPHRATE

Helotes, Texas

Phone: 970-988-9854

Email: jdouph@gmail.com

Website: <http://collectorsofwoodart.org/artist/portfolio/222>

In 2013, when Jeanne Douphrate was first introduced to the lathe, she knew at that moment she had found her artistic medium. Though her professional career is in healthcare administration, since childhood, she has desired to pursue art as an avocation. With her three sons nearly all school-age, she had reached the right time in her life to begin learning the art of woodturning. In a few short years, with the help and encouragement of several local and nationally-known woodturners, she has made great strides. Like many new turners, she began with pens and bottle stoppers, which were given away to family and friends. She moved on to bowls and vessels for a short period of time, but now concentrates on sculpture. Her art examines the human spirit in visual metaphors. By creating sculptural representations of common objects, such as water, vessels, and plants, she interprets thoughts and emotions that are common to the human experience. Jeanne's first sculpture, *Conflicting Desires* (2015), was awarded Best

in Show in her first ever juried exhibit. In 2016, she was awarded the Excellence in Education Award from Marc Adams School of Woodworking for her sculpture *Sharing Spirit*. Her works have been selected for various juried exhibitions over the past two years. Wood is Jeanne's medium of choice because of its warmth, smells, textures, and natural beauty. However, she finds the most enjoyable aspect of woodturning is the people and the incredible friendships she has made.

JAMES DUXBURY

Elegant Creations

Division of Duxterity LLC

Home of the Resp-O-Rator™

Website: www.duxterity.com/ec

Jim Duxbury is an artisan with over 50 years of experience who “thinks out of the box.” An active member of the American Association of Woodturners, Carolina Mountain Woodturners, Piedmont Triad Woodturners, and North Carolina Woodturners Guild, he has won numerous awards and ribbons with his original kaleidoscope designs.

Although Jim has claimed to be retired since 1996, the abundance of dust from woodturning evolved into the invention of the Resp-O-Rator™ of which he holds two U.S. patents. He and his wife Rita operate Duxterity LLC for the manufacture and marketing of both the Resp-O-Rator™ and his gallery quality wooden objects.

Jim resides in Graham, North Carolina. With the help of his wife Rita and Parrotlet “Bean” he creates all sorts of fine turnings from small bottle stoppers to bowls, bud vases, trays, furniture, wooden hats, chandeliers, and, of course, his fine kaleidoscopes.

LINDA FERBER

Facebook: [linda.ferber.9](https://www.facebook.com/linda.ferber.9)

Linda Ferber has been turning for over twelve years and enjoys the creative possibilities and personal challenges woodturning provides. The opportunity to try woodturning presented itself back in 1999 when her dad had an auction including his shop equipment. Linda choose to purchase the lathe thinking with this one piece of equipment she could continue working with wood. With no previous experience with a lathe she took a bowl turning class and found the local chapter of the AAW. Looking back that one impulse purchase at an auction has made a big impact on her life.

JOE FLEMING

11717 Caminito Vantana

San Diego, CA 92131-2109

Phone: (858) 395-0562

AirbrushingWood.com

Joe Fleming has been an amateur woodworker for over 40 years and an amateur woodturner for more than 15 years. His skills are primarily self-taught with assists from various class work, from woodworking publications, and through participation in various woodworking clubs. Joe has studied with many noted wood artists including, Allan Batty, Stuart Batty, Christian Burchard, Jimmy Clewes, Don Derry, Michael, Hosaluk, John Jordan, Binh Pho, Richard Raffan, Merryll Saylan, and Susan Working. His dad gets the credit for instilling in him a passion for hand-made wood items.

2107 SWAT

Joe is a member of: San Diego Woodturners, San Diego Fine Woodworkers Association and American Association of Woodturners.

Artist's Statement

Woodworking provides me with an outlet for my creativity. I enjoy finding a piece of wood, envisioning what it can become, and then transforming it into a beautiful art or craft piece. I make both art pieces and functional pieces, but I always strive for beauty. My woodturning consists all types of turning disciplines including bowls, hollow forms, platters, vases, boxes and furniture components. I use a variety of wood species in my work including local urban-forested woods like eucalyptus, and other reclaimed wood. I also use wood from certified forestry projects in the Pacific Northwest, Mexico and Australia.

GEORGE FREEMAN

7151 Sandy Lake Rd

Quinlan, Texas 75474

Phone: 903-356-0859 (Home)

214-334-4035 (Cell)

Email: woodchipper2011@hotmail.com

George Freeman grew up in Boyd, Texas on the Trinity River Bottoms farmland and woods. He was the owner of Creative Concepts in Landscaping in Dallas for several years, which was a complete design/landscape/irrigation/stone laying business. He also had a companion nursery growing operation for trees and shrubs in East Texas at the same time.

George was a Dallas Fireman for 45 years and retired in June 2015. He enjoys woodworking and woodturning in his shop. George owns a sawmill and chainsaw mill used to cut specialty lumber sizes. He spends a lot of the time in the woods gathering trees for the sawmill and logs to turn into turning blanks. Currently, George has 33 different species of trees he uses for woodturning blanks.

Member: Hunt County Woodturners and Dallas Area Woodturners

ROBERT HENRICKSON

264 Burke Road

Lexington, KY 40511

Phone: (859) 252-9334 (Home)

(859) 492-3330 (Cell)

Email: R.C.Henrickson@twc.com

Turning first intrigued me while I was a grad student in archaeology, although some years passed before I actually began. The departmental collections included window lattice-screens (mashrabiya) from Egyptian houses and palaces in 15th-18th century Cairo. These panels consisted of literally hundreds of turned wooden spindles and small connectors, assembled densely along either a rectilinear or hexagonal grid. They were striking in their intricacy, yet simple in their components. They appealed to my interest in geometric patterns and drew me to explore their construction. It was some time even after I began turning that I finally starting working from this basic inspiration.

In turning, my goal is to highlight the natural colors, grain, and texture of the wood through the shape used for each piece. Kentucky is rich in beautiful hardwoods; I prefer to turn local rather than imported woods. Simple finishes, usually satin or matte, let the wood show its colors and character. I may enhance natural colors subtly, such as darkening oak by fuming with ammonia.

I am an exhibiting juried member of the Kentucky Guild of Artists and Craftsmen, member of the American Association of Woodturners, Bluegrass Area Woodturners, Ohio Valley Woodturners Guild, and Louisville Area Woodturners, and have done woodturning demonstrations on a wide range of topics.

AL HOCKENBERY

<http://swat.hockenbery.net/>

When I get near a lathe, I like to make chips and watch good things happen.

I bought my first lathe in 1975, got serious about turning in 1987, and I've been learning to turn ever since. My work reflects my interest in math, nature, and ancient cultures. I have had success with natural edge hollow forms, suspended spherical forms, ball in a ball, and recently, sand-carved forms. Along the way, Sherry Hockenbery became a fine turner and we have been able to teach classes together and have joint shows in galleries. In 2004, Sherry and I moved from Maryland to rural Florida. We have a great big shop where we do some teaching and host workshops. Through the AAW, Sherry and I have been surrounded by friends with a passion for woodturning, an appreciation of turned objects and a genuine interest in our respective journeys in woodturning.

ALAN LACER

299 Plainview Drive
River Falls, WI, 54022
Phone: 715-426-9451
Fax: 715-426-9451
Email: alan@alanlacer.com
www.alanlacer.com

Alan Lacer has been involved in the turning field for over 40 years as a turner, teacher, writer, exhibition coordinator, expert witness, demonstrator and past president of the American Association of Woodturners. His work has appeared in a number of regional and national exhibitions. Alan has been a regular instructor and demonstrator of the craft--having worked in all 50 states as well as 5 foreign countries. He has published over 150 articles, columns and tips, covering technical aspects of woodturning, many specific projects, stories related to both contemporary and historical woodturning and the turning traditions of Japan and Germany. He has also produced five videos on his own, with three of them winning a total of five national awards. He has published one book with another in progress. In 1999, the American Association of Woodturners awarded him their Lifetime Honorary Member Award for his contributions to the field. He has also appeared on national TV woodturning programs on PBS and DIY.

JANICE LEVI

204 Private Road 5822
Groesbeck, TX 76642
Phone: 254-729-2542
Email: jlevi@rightturnonly.net
Website: www.janicelevi.com

I have been turning wood for 15 years and am a member of Gulfcoast Woodturners Association (Houston area) and Brazos Valley Woodturners (Waco area). I have also been involved with Southwest Association of Turners (SWAT) and served as president in 2012. I demonstrate and

2107 SWAT

teach classes in several areas including ornaments/finials, pyrography, jewelry, purses, and basic turning skills. My background is in education and I have taught high school journalism and drama. I then served as a counselor for at risk and discipline problem students.

As a child, I was blessed with parents and brothers who constantly challenged me to try new things, to experiment, to explore, to analyze, to create. As an adult, I entered the field of secondary education, and have taught journalism, photography, and drama. I then became a counselor, working with at risk and discipline problem students in alternative school settings.

A few years from retirement, I revived an old interest from my childhood—my father's old Sears lathe and those times that he would let me hold a turning tool to a scrap of wood. I wanted to do that again, so in 2001, my husband gave me a lathe for my birthday. I immediately joined the local Houston area woodturner's organization and found that I had just entered a man's world. But the men were gracious and two who lived nearby became my mentors, insisting that I learn toolmanship and safety.

I was fortunate to serve as president of the Houston area club, the Waco club and SWAT 2012. Although I was honored to serve those organizations, it has always been the turning, the teaching and the demonstrating that I have really loved. In recent years, I have begun turning purses and jewelry, a great way to wear those wonderful pieces of turned art out in public. Today, woodturning has become more than a hobby—it has become my passion. After fourteen years, it is as new and as challenging as it was when I first started.

ERIC LOFSTROM

PO Box 517

Enumclaw, WA 98022

Phone: 253-320-4788 (cell)

Email: Eric@EricLofstrom.com

Website: EricLofstrom.com

Elementary teacher by day, woodturning artist by night, Eric Lofstrom is a dynamic and passionate instructor. Conscious of the importance tool control plays in the process of creating, Eric's unique expertise in biomechanics and understanding of tool design permeates his teaching with a constant focus on technique. As a seasoned teacher, Eric communicates complex concepts in easily understood language. He believes it is important to understand the "why" and "how" of technique, not just the "what". Eric's passion and exuberance will inspire your world of woodturning with confidence to develop your own artistic voice!

DAVID MUELLER

Website: www.aggieturner.com

I am Dave Mueller (a.k.a. AggieTurner), a retired executive who enjoys wood turning, computer gaming and gardening (in that order). I have been turning for about five years and am still trying to find my favorite style. You can see what I have learned so far by going to the My Turnings webpage.

Also, on the Useful Links webpage, please visit the BV Turners website to see what the turners in the College Station area are doing.

JOSH REID

No contact information available

No information available

CURTIS SEEBECK

TurnTex Woodworks
531 Hunter Ridge
San Marcos, TX 78666
Email: Curtis@TurnTex.com
Website: TurnTex.com

CURTIS SEEBECK is a recognized pioneer in the field of casting and stabilizing wood. As the original inventor and producer of the "Worthless Wood" resin and wood hybrid concept, he has made significant innovations in the field of stabilizing and casting. This includes the creation of Cactus Juice Stabilizing Solutions as well as providing technical advice on the formulations used by the Alumilite Corporation for their proprietary casting resins. He is a member of American Association of Woodworkers (AAW), the Central Texas Woodturning Association, and the International Association of Pen Turners. He has demonstrated at The Southwest Association of Turners (SWAT), the Utah Woodturning Symposium, numerous woodturning clubs and craft schools across America. Curtis works full time in his company, TurnTex Woodworks, building vacuum chambers and providing technical support for craftspeople who are stabilizing and casting, and is world renowned in his field.

JIM TANKSLEY

No contact information available

I began woodturning in 1969 in 9th grade woodshop. All I can remember is we laminated maple and mahogany together to turn a lamp. I don't remember if I used a gouge or a crow bar. My mom loved it.

I didn't turn again until 1995 to turn some 6" diameter white oak legs for a dining room table. To turn the table legs I purchased a lathe from Big Lots. The lathe had the capacity but not the power; I ended up burning up 3 lathes before they told me to not come back. To finish the project I purchased a Sears lathe at a garage sale. The experience wasn't that much fun because the lathe shook all over the place and was constantly staling.

My next opportunity to turn happened in 2005. I worked at the same company as another club member and noticed he had a good-looking pen. I asked him where he got the pen and he said he made it. He told me all I had to do was to go to Rockler or Woodcraft and buy a mandrel and pen kit to make my own. I wish it were that easy and cheap. It turned out the Sears lathe didn't have a number 2 morse taper so I couldn't make a pen without buying a new lathe. I bought a Jet Mini and was making pens in no time after attending a few club meetings and getting some tips from the old timers.

It wasn't long and I was getting bored with turning pens. A member was selling his Nova 3000 for \$800 to buy a Powermatic. I purchased the Nova to turn bowls. The Nova is a good variable speed lathe with 1 ½ hp DC motor. I especially liked the rotating head to make it easier turning bowls. At first I did everything wrong and scrapped over 50%. It took me the longest time to learn the lingo, in fact I could turn a bowl before I knew a live center from a banjo. The Nova 3000 would turn up to a 16" bowl and my wife loved everything I turned. I became inspired to learn more.

Instead of taking lessons I bought a bigger lathe, thinking a bigger lathe would allow me to turn better – ha ha! The first day I got the 3520B I turned the biggest log I could find, a piece of Sycamore approximately 18" by 12". Within 90 days I broke the banjo on the Powermatic. I called them up and told them what had happened (a bad catch) and they replaced it for free. I

2107 SWAT

continued to go to club meetings, asked questions, paid attention during the demos and took lessons every year when the club brought in professional demonstrators.

My turning has continued to improve over time. The most impactful lessons I have taken were from Stuart Batty. In 2015, I purchased the Robust American Beauty to have 25" capacity between centers. I primarily use the push cut with 5/8" or 3/4" bowl gouges. I prefer turning green wood. Mesquite is my favorite but have turned large bowls out of Silver Maple, Bradford Pear, Oak, Pecan, Black Walnut and Hackberry.

Previous Demos and Exhibits

January 2017 - Demonstrated how to turn Natural edge end grain bowls from Mesquite Logs. Golden Triangle Woodturners

November 2016 – How to turn Christmas Trees from Mesquite. I have a unique way of turning Christmas Trees from Mesquite that gives the appearance of snowy branches. Dallas Area Woodturners

August 2015 - How to turn a Large End Grain Natural Edge Mesquite Winged Bowl. SWAT

September 2014 - How to turn Christmas Trees from Mesquite. I have a unique way of turning Christmas Trees from Mesquite that gives the appearance of snowy branches. Woodturners of North Texas

October 2012 – Large Bowls. Discuss how to cut the log and techniques on turning a natural edged mesquite bowl (end grain and side grain). Woodturners of North Texas

October 2016- Displayed a collection of large turnings at the Fort Worth Arts Goggle

December 2014 - Exhibit at Fort Worth Community Art Center. Held Reception with 7 other wood turners and discussed displayed turnings, methods and materials to a large number of visitors

MOLLY WINTON

5517 160th PI SW

Edmonds, WA 98026 USA

Phone: (425) 743-3770

Email: TurningMaven@hotmail.com

Website: turningmaven.com

I was introduced to woodturning while in high school, but it wasn't until 22 years later that I again stepped in front of a lathe. In 1998, I sold my Vocational Rehabilitation business so I could be home with my growing family. At the time, my husband presented me with a lathe of my own, but I wouldn't have the opportunity to work with it regularly until my children reached school age.

A brief exploration in pottery introduced me to the importance of form and design, the foundation to any embellishment of my turning, be it branding, pyrography, coloring, texturing, or carving. I endeavor to make wood pieces that pursue excellence of form and beg to be picked up and caressed.

When exploring a source of inspiration for my surface enhancements, I looked to my interests in Native American and prehistoric art. Since childhood I have been fascinated by the creative expression of native North American cultures, petroglyphs (prehistoric rock carving) of the Columbia Plateau of the Northwest, as well as the cave art of Lascaux, France and Altamira, Spain. My artwork reflects their influences.

LIST OF DEMONSTRATIONS

Demonstrator	Project	Page
Sally Ault	Surface Carving w/Sandblaster	29
Doug Baldwin	Light & Shadow - Photographing Wood Objects	31
Trent Bosch	Revelations in Hollowing	35
	Sunburst Platter	35
	Vessels of Illusion - Hollow Form, Carving & Wood Bending	35
Jim Bob Burgoon	Between Centers Pens & Other Applications	43
Les Casteel	Turning Old & Antique Wood Pulleys	47
Andy Cole	Hawaiian Calabash Bowl	51
	Natural Edge Nested Sets	53
	Sunny-side Up Egg on a Platter	55
Jeanne Douphrate	Curves in All the Right Places: Designing Attractive Forms	57
James Duxbury	Illusions - Unique Decorative Four Center Turning	61
	Traditional Kaleidoscopes	63
Linda Ferber	Make a Button Cylinder Pendant	67
Joe Fleming	Airbrush Art - How to Successfully Transfer Images	73
	The Airbrush Demystified	73
George Freeman	Wood Choices for Woodturning Projects	79
Robert Henrickson	Snowflakes & Beyond - Doing More with Spindles	85
Al Hockenbery	Natural Edge Bowl from a Crotch	89
	Sand Carving - Design & Create Images	95
	Turning Triangles - Unique Multi-Center Turning	97
Alan Lacer	My Friend the Skew	101
Janice Levi	Bangle, Pendant, and Earrings	107
	The Fine Art of Finials	109
Eric Lofstrom	Skew Skills - Making the Cuts	113
	Square Rimmed Bowls	115
David Mueller	Use of Ground Plastic Beads as Enhancements	117
Josh Reid	Crush Grind Pepper Mills	123
Curtis Seebeck	The Science & Art of Stabilizing Wood & Other Porous Materials	127
Jim Tanksley	How to Turn Natural Edge End Grain Mesquite Bowls	131
Molly Winton	Making Mini Vessels & Carving Texture	133
	Pyrography Tips & Tricks	133



TURNING 26 WITH SALLY AULT



Surface Carving w/Sandblaster

Sand Sculpting wood..."let the grain shine"

I use sandblasting (more accurately called Abrasive blasting) to allow the landscape of the wood grain to become much more pronounced than it would be if it was sanded smooth. I choose the wood for its grain patterns and growth rings and accentuate the characteristics of the wood by sandblasting.

You can sandblast any wood but soft wood with very distinct growth rings will give you the best result.

Growth rings are created during different parts of the growing season. Early wood (beginning of the growth season) is faster growing, has larger cells and is lighter in color than late wood (at the end of the growing season) which is slower growing, has denser cells and is darker in color.

Growth rings occur because of seasonal temperature difference or in some areas because of wet and dry seasons.

Ring shape can be affected by factors such as growing in a windy area, which causes faster growth on the side away from the wind as the tree attempts to grow straight. A tree that is stressed by lack of light or water or by insects or fungus may also have uneven growth rings.

A species, which has distinct differences in the soft and hard wood and in the size of the rings, is a great choice for sandblasting.

Some of the woods I like to sandblast are Redwood, Douglas fir, some varieties of pine, Ash, Cedar and Russian olive.

The media you use for sandblasting will give you different effects. I use ground or crushed glass. It is very abrasive and does a great job of removing the soft wood.

Other types of media used in sandblasting are Aluminum Oxide, glass beads and walnut shells.

I prefer the crushed or ground glass because each tiny particle has sharp edges which erode the soft grain well. The ground glass does not color the wood.

Aluminum oxide tends to leave dark particles in the soft grain. Walnut shells and glass beads are not aggressive enough for the amount of erosion I like to do.

DO NOT use sand. As the sand breaks down the particles in the air can cause silicosis of the lung....which can be deadly.

I buy "Ballotini" ground glass in a 50-pound bucket from Amazon but some areas may have a local source. Harbor Freight also sells it in small containers.

Grain erosion alone is often enough to make an otherwise ordinary piece more interesting but I also like to mask areas to be left proud of the surface and erode the wood around the masked area.

My preference for a mask resist is a thick slightly flexible material with a sticky back called Anchor Blast Lite Stencil T226. It is available from USCutter.com.

2107 SWAT

I have tried many other materials as a resist...blue tape, green tape, duct tape, electrical tape, Gorilla tape, shelf paper...and double thicknesses of all the above. Most either peel up easily during the blasting process or they allow the pressure of the blasting to dent the soft wood under the tape.

The Anchor Blast lite mask is easily cut with an exacto blade or with a vinyl cutter.

An enclosed blast cabinet is ideal....but people have been known to use a gravity feed sandblaster with the piece in a box or plastic bag.

Sandblasting cabinets are available in several sizes and an entry level cabinet is not too expensive. Having an enclosed cabinet allows much more efficiency since the media recycles continually. A blasting cabinet should seal well and have a shop vac attached to draw out the cloud of particles, which can obscure your view of what you are doing.

Good light is important. Some cabinets have a reasonable light inside the cabinet. I add a light in a shop light fixture pointing down through the glass window.

Care should be taken to avoid having the blast stream point toward the window....it will become very difficult to see what you are doing if it gets blasted. You can get "tear-offs" to put on the inside of the window to protect the glass.

While you are sandblasting you should always wear a respirator.

Sandblasting requires a big compressor. My Harbor Freight freestanding cabinet has a requirement of 9.5 CFM at 90 psi. I have a large compressor but I still have to stop occasionally and let the compressor build up pressure. The delay is a good time to open the cabinet and inspect your work.

When you are directing the stream of abrasive at a masked piece of wood, it is really important to aim the blast from the center of the mask toward the edge. If you move the stream toward the edge, the mask will very likely start to peel up and you will lose your crisp edge. I like to go over the whole piece fairly lightly to start with and then look at how the grain of that particular piece of wood reacts to the abrasive. That will allow you to make a design decision about where you need to concentrate your blasting.

One cool effect is to hold the nozzle in one spot to create a dimple.

If your wall thickness is thin enough you can actually blast through the soft grain....but be sure the wood has medullary rays to hold it together...or make sure that your mask creates enough structure that going all the way through the grain doesn't make the piece collapse.

There are other ways to erode the grain on a piece. A stiff wire brush held against the piece as it spins on the lathe gives good erosion with a different look. The hard wood becomes scratched as the soft wood is eroded which it can be a very good looking surface. A wire brush can be held in a drill and worked across the grain as well. That technique gives you a bit more control of where you erode. You will get a different look by going one way or both.

Treatment of the eroded wood can take many different directions. You can use an oil finish, spray with lacquer, stain it, dye it, paint it, use ebonizing liquid (especially on woods with strong tannic acid) or whatever else you can think of.

Have fun!



TURNING 26 WITH DOUG BALDWIN



Light & Shadow - Photographing Wood Objects

Objective Criteria for Successful Photographs

1. Overall Exposure
2. Highlight Detail
3. Shadow Detail
4. Edge Separation
5. Color Balance
6. Lighting for Shape
7. Area of Focus
8. Background
9. Photo is Part of a Portfolio of Work



1. **Overall Exposure** - The overall light and dark balance of the photo.



Correct Exposure

2. Highlight Detail - Sufficient or resolvable detail in the lightest parts of the art piece in the photograph.



Top: Blown Out Highlights
Bottom: Correct Exposure

3. Shadow Detail - Sufficient or resolvable detail in the darkest parts of the art piece in the photograph.



Top: Shadows Too Dark
Bottom: Correct Lighting & Exposure

4. Edge Separation - The edges of the art piece must clearly separate from the background. The piece must not blend in along its edges.



Top: Top Rear Edge Too Dark
Bottom: Correct Lighting & Exposure

5. Color Balance - The photograph must be properly color balanced to display the items correctly. No color shifts should be evident.



Top: Overall Color to Warm
Bottom: Correct Color

6. Lighting for Shape - The lighting must support the dimensionality of the piece being photographed. The object being photographed should have highlights and shadows to maintain the shape of the item.



7. Area of Focus - The most important part of the item being photographed must be in sharp focus. Sufficient depth-of-field must be maintained for all relevant parts of the item being photographed.



8. Background - The background should support the item being photographed and not detract or call unnecessary attention to the background. Avoid the use of strong colors or textures in the background.



9. Portfolio of Work - Each photo should be a part of a cohesive portfolio. Similarly styled photos support the artist's vision of their creative endeavors.



Creating the Photograph

1. Camera Choice
2. Lens Choice
3. Exposure Setting
4. ISO Setting
5. White Balance
6. Quality or File Size Setting
7. Shutter Speed
8. Aperture or f-stop
9. Picture style
10. Lighting



To view more photos,
purchase lightboxes and
see the upcoming class
schedule, go to:
DougBaldwinPhoto.com





TURNING 26 WITH TRENT BOSCH



Revelations in Hollowing

Sunburst Platter

Vessels of Illusion - Hollow Form, Carving & Wood Bending

Objective

Over the past 15 years, I have been exploring the creative possibilities and the unlimited potential that turning and sculpting wood has. This information sheet is to be used as a supplement to my hands on classes and demonstrations. My objective is to broaden your knowledge base and to expand your potential creative possibilities. There are many ways to approach woodturning, below are some that work for me, you need to find what works best for you and, as always, enjoy the creative process.

Materials

I use mainly green (the wetter the better) domestic hardwoods, acquired from arborists or individuals removing trees due to development, old age or storm damage. My favorites in my area include silver maple, ash, honey locust, elm, etc. I rarely turn down a piece of wood even if it is not one of my favorites (you never know).

Cutting the Material

Starting with the log allows you to have complete control over the process giving you the ability to lay out the grain in any manner you see fit. I usually begin by removing the pit (center of the tree). This will remove an area that is prone to cracking. Although this is a general rule, there are certain situations where the pith being included will create interesting grain patterns.

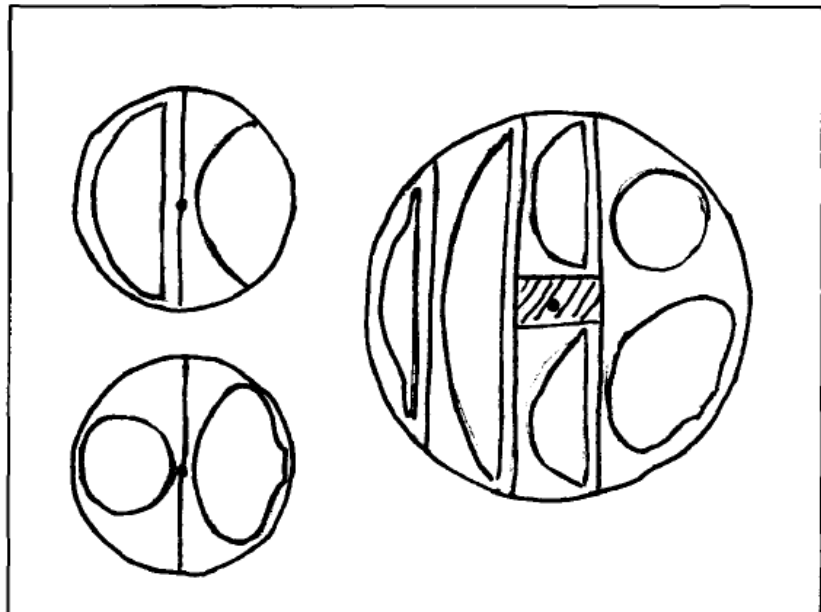

Layout of various forms in small and large logs

Grain Structure

Paying attention to the grain structure of the wood is important for two reasons. 1) The aesthetic success of the piece relies on thoughtful layout. 2) Cutting the wood the proper direction will allow for much cleaner cuts, which, in turn, cuts down on sanding time.

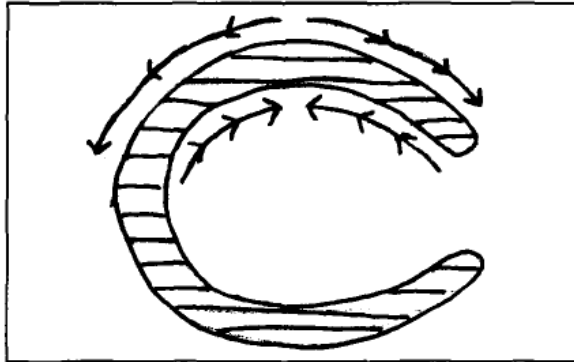

End Grain Direction of Cut

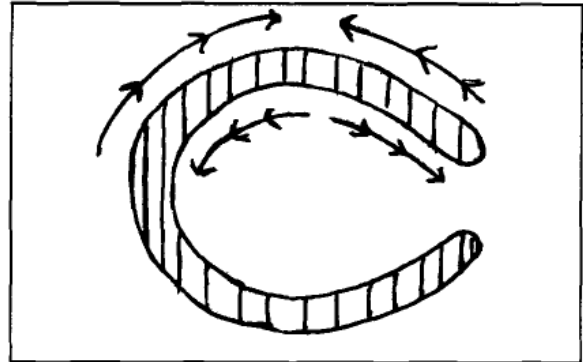

Face Grain Direction of Cut

Tools

My basic tools include: 5/8" bowl gouge, swept back grind, 3/8" bowl gouge finish cut grind, 3/8" spindle gouge, fingernail grind, double ended scraper, and hollowing tools.

I use the sweptback grind bowl gouge about 85%-90% of the time I am on the lathe.

Sharpening

- Wheels: 60 grit works best (bread knife theory).
- Grind very carefully like you are grinding your fingernail. It does not take much pressure at all.
- Jigs are great if they get you the grind you want. To get the best results with jigs, do not change the set up. Consistency is a very important part of using jigs.

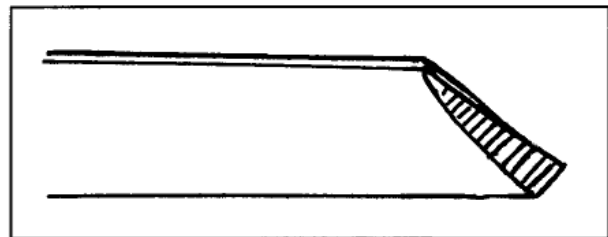
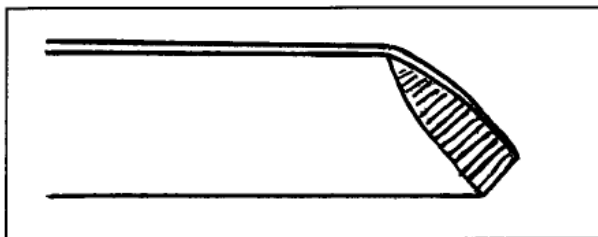

Best grinds for the sweptback grind gouge, with a 60-degree bevel angle.

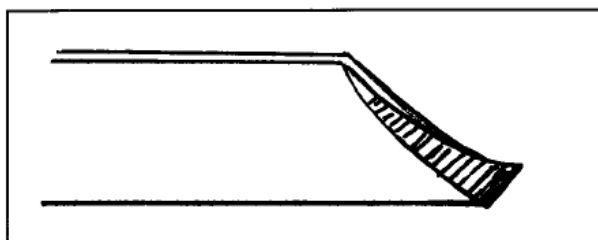

Grinding too much on the sides.

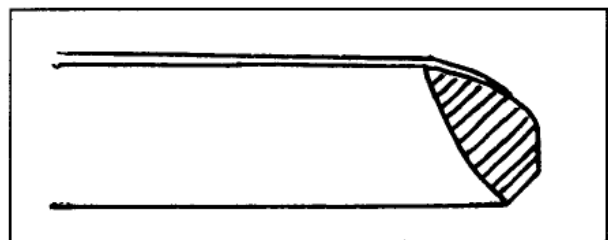

Grinding too much on the front.

Slow Speed versus Fast Speed

Slow speed (1725) is better to learn on or for doing grinding by hand.

Fast speed (3250) is for use with jigs and more experienced grinding.

The height of the grinder is important. Get it up higher so you can see what you are doing. I set the height of my lathes to about 2" above my elbow. This is also, where I put my grinder.

Tool Usage

Ride the bevel, ride the bevel, and ride the bevel!

Doing so gives increased control and will slice the wood off rather than rip it off.

Riding the back of the bevel will make the tool cut out – riding the front of the tool will make it cut in. This is controlled by the movement of the tool handle. This is what allows you to shape the wood into the desired shape.

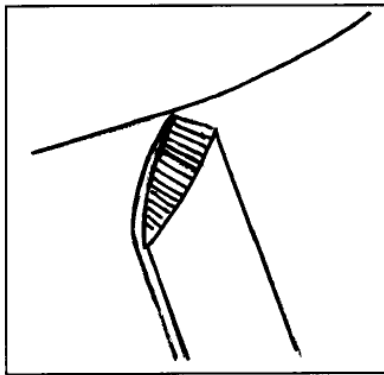

Riding the Front

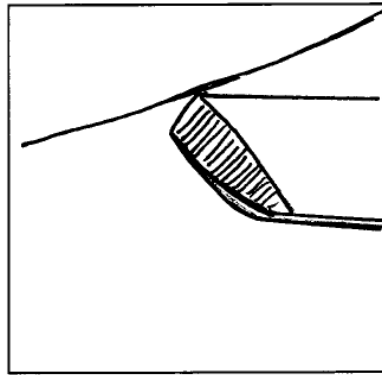

Riding the Back

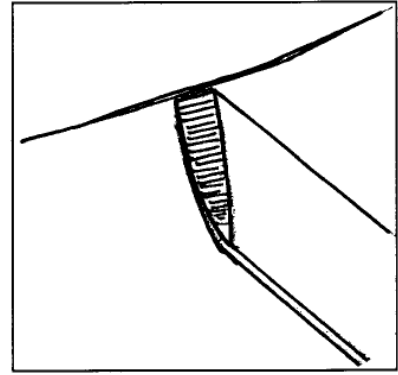

Just Right

Use the tool you are most comfortable with and from which you can get the form you like.

Sheer Scraping Cut versus Shearing Cut

Sheer scraping is still scraping. It is just at an extreme angle that allows the tool to get more of a shearing cut reducing tear out.

A shearing cut will always produce a very clean cut if used properly. But, it is hard to get into some locations and getting a good fair curve takes some effort.

Lathe

- A good stout lathe is important and will not hamper the creative process.
- Set up the lathe so the center of the spindle is about 2" above your elbow. This will allow you to turn for extended periods of time without fatigue.
- Variable speed is great and should be considered a necessity.
- Cast iron is an ideal machine tool material.
- I would make the same object on any lathe of good quality (a \$6,000.00 lathe will not make your work better than a \$2,000.00 lathe).

Safety

When using machinery of any kind you need to always be focused on the task at hand – do not let your mind wander. Accidents happen when you are not paying attention to what you are doing. If you find yourself getting fatigued or tired mentally or physically, it may be time for a break.

Eye protection, face shield, ear protection, no loose clothing or hair, etc.

You should go through a safety checklist before you turn on the lathe.

- Proper personal safety equipment
- Tailstock in place and tight
- Lathe on the lowest speed
- Tool rest won't hit the piece when the power is applied
- Material is suitable for turning
- Area is clear of others

Lathe Speed

There is no super easy formula for figuring out the best speed. The speed on a large piece will be much slower than the speed on a small piece. The best approach is not to turn the speed up any higher than a speed with which you feel comfortable.

Hollow Forms

Mount the piece between centers to allow you to change the axis of the piece if needed for design considerations or removal of a defect. I do both face grain and end grain hollow forms. Tooling – you will need tools to allow you to remove the inside. Long and strong are important. The tool will have to hang far off the tool rest. Find a set of tools with which you feel comfortable and use them a lot. There is no substitute for practice.

Shape the exterior to its final shape first. Leave the bottom with extra material for support of the hollowing process.

Do not begin hollowing until you are totally satisfied with the exterior shape. Once hollowing begins, you will not want to go back to the outside.

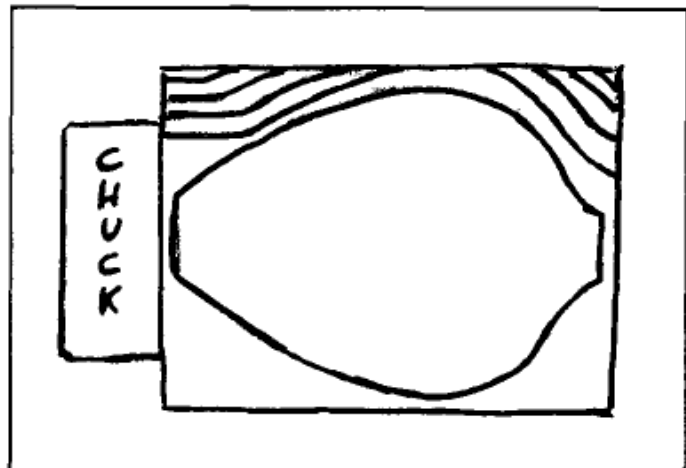

Shaping the Outside

Steps in hollowing:

- 1) Drill a hole down the center to ½” above the expected outside depth.
- 2) Open up the vessel all the way down to the bottom of the hole.
Note: steps 1 and 2 could be accomplished with a forstner bit in the tailstock. (I prefer to do it as described in step one and two.
- 3) and 4) Open up the hold, further allowing more room in the vessel.
- 5) Get around the top corner starting to refine the final wall thickness.
- 6) Saved for last to allow support for the other steps.

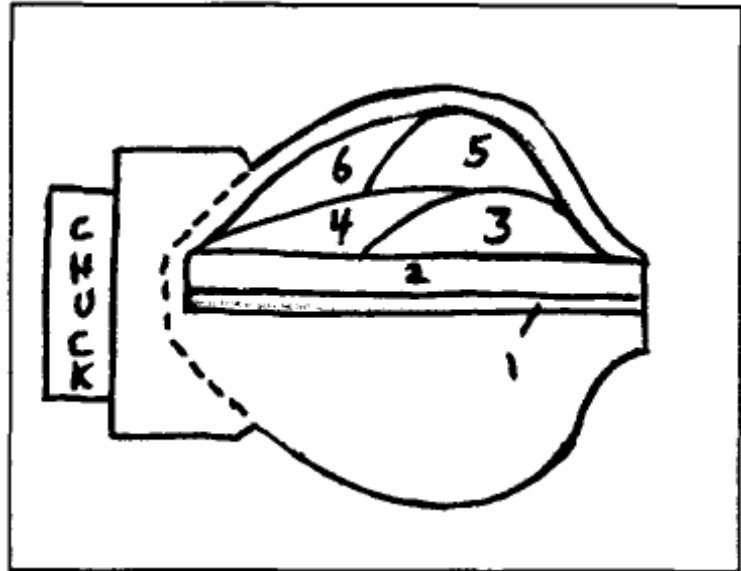

Steps in Hollowing

Steps 2-4 Straight Tools

Steps 5-6 Bent Tools

Hollowing Tool Tips

- The bent tool needs to be used with the bent part in front of the tool rest.
- A good bent tool will have the cutter on center with the shaft.
- Smaller scraper tips will allow you to cut more aggressively without the risk of the tool grabbing.

Bowls

Primarily face grain.

Mount on a faceplate, screw chuck or between centers.

Start after your final shape right away. Don't worry about truing the blank up. This will allow you to develop your final shape all through the process.

Try using a left-handed cut. This will allow you to throw the shavings away from you rather than in you face.

(Ride the Bevel)

Get the shape on the outside exactly how you want it before flipping it around.

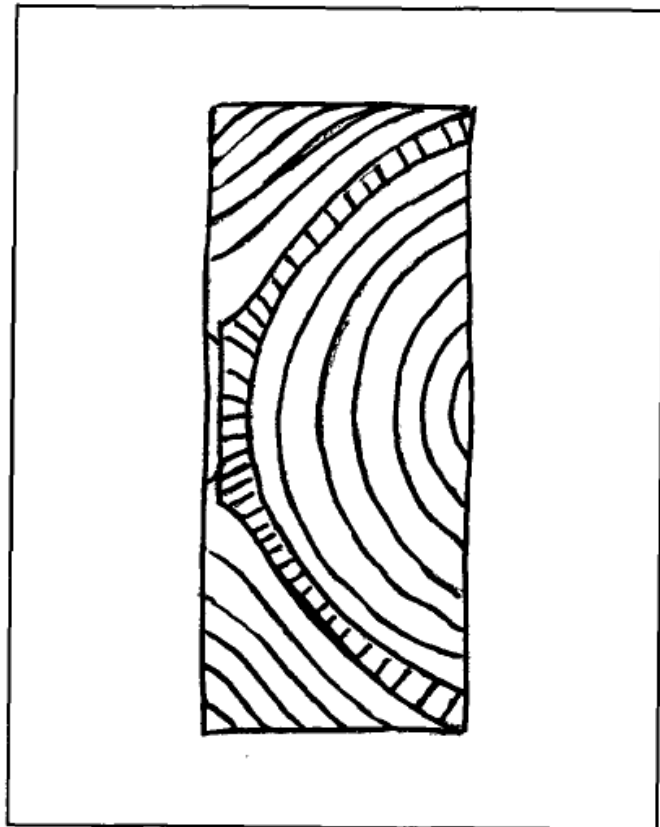

The bowl inside is done very similarly to the outside starting with your bowl shape from the beginning. This will allow you to shape the inside without a lot of funky transitions.

If it is a large bowl, you may have to take it down to a heavy version of your final shape. Then you will work down the bowl in steps as shown, refining them and blending them together.

Bowl Profile for a Utility Bowl

I prefer thick around the rim for strength and thinning out below for a lighter feel.

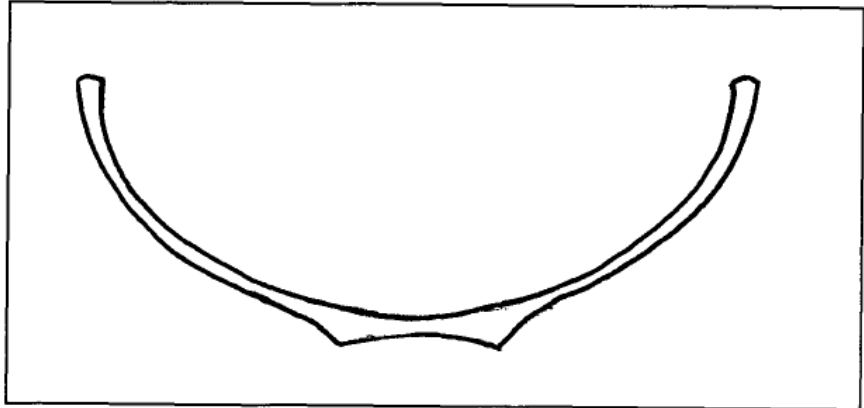

Chucking

Know the type of tenon your chuck requires.

- Chucking diameter
- 4 things to which to pay attention:
 - 1) Right diameter for the size jaws you are using.
 - 2) Create a flat for the face of the jaw to register up against – can also be slightly faced in.
 - 3) Make the tenon the right length – you want the face of the jaw to register up against the flat of the bowl. This is where you get all your support.
 - 4) Cut a sharp clean tenon if you leave a small radius in the corner of your tenon, it will not allow it to register up to the part appropriately.

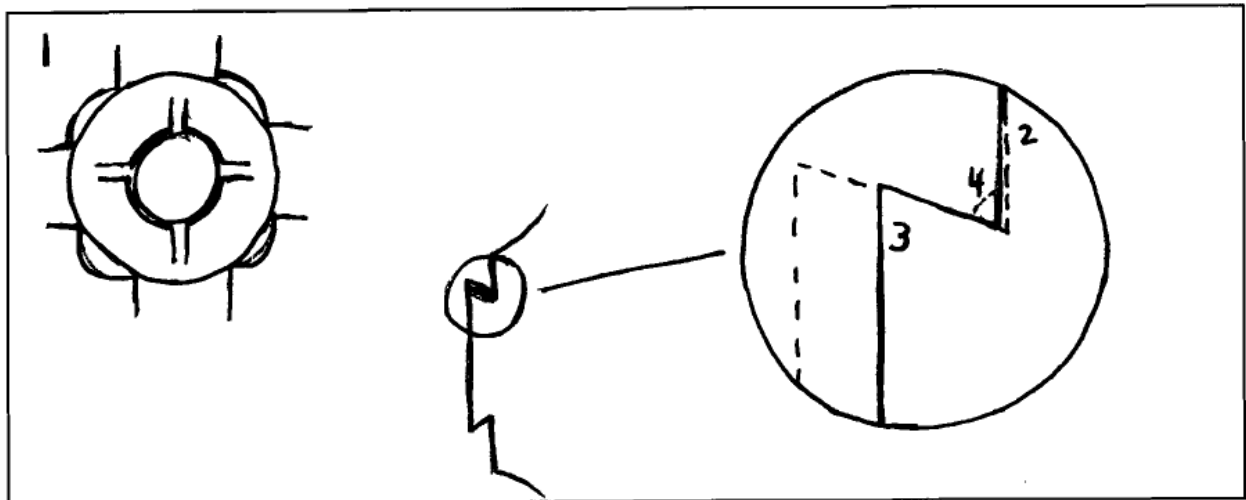

Sanding Tips

Sand with the lathe at a slow speed. This allows the paper to cut without as much heat and lets you actually cut with the paper not just glaze over the surface.

Start with coarse paper that will make larger scratches and work down to finer and finer grits until it gets down to scratches you can't even see.

Take your time. Do a good job. This is one of the final steps and, if it is done right, will help the piece succeed.

Carving and Sculpting on Turnings

When you plan to carve on a piece, make sure you leave enough material to allow you to develop the effect you are after.

Often I will use a softer material such as clay or a foam that sculpts easily such as floral foam. Use these materials will allow you to refine and make decisions about the carving before working in the harder material.

Use of a carving stand or work holder allows you to focus your attention more on the carving and less on holding the piece. Making the use of sharp tools much safer.

Carving Tools I Use Frequently

Reciprocating:

- Air body saw uses an 18tpi hacksaw blade, roughs out work very quickly.
- Reciprocating carver using flexcut cutters. V shape cutter is my favorite.

Rotary:

- Die grinders using various burs. I like the Kutzall extreme and the foredoom typhoon burs in various shapes.
- Micro die grinders small version of the die grinder for use in tighter location with smaller burs.
- Flex shaft tools.
- Angle Grinders with various attachments

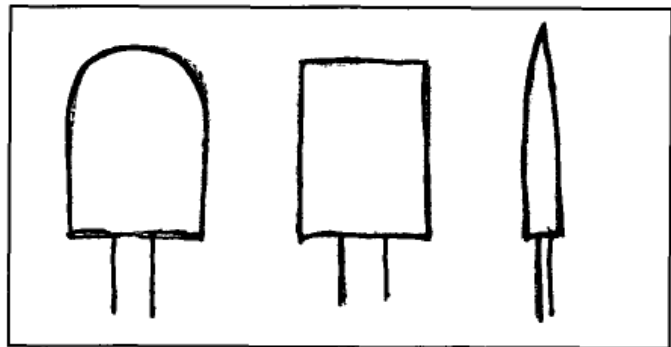

My favorite burr shapes

Surface Treatments

The possibilities are endless. The list below is not even close to a complete list but can be used as a starting point.

Inlays, Carved textures, Pyrography, Metal Leaf, Piercing, Sandblasting, Indentions, Paints, Dyes, Airbrushing, Burning, etc., etc., etc...

Finishing

I look for a few different things in a finish. I want it to be fast, easy to apply, and appropriate for the piece.

One of my favorites for utility pieces includes mineral oil/walnut oil – they are easy to use and non-toxic. They can also be refinished by the end user and give the piece a nice subtle look. I also use beeswax/mineral oil or walnut oil/beeswax mixture on the pieces as well.

For more decorative pieces, I use a spray lacquer such as Deft. It works fast and easy. Also, Waterlox transparent works great. It is a wipe on oil that dries fast and builds up a nice sheen. The more coats, the glossier the finish. I usually put on 3-4 coats and cut it back with 0000 steel wool until it has the desired sheen for me.

If I am sandblasting or want to leave the wood feeling, looking natural, I will use a spray fixative (used to seal charcoal or pastel drawings so they won't smear). It leaves a very thin coat on the surface of the wood to protect it from the oil of your hands, but leaves the wood looking almost unfinished.

Design

Spend as much time as you need getting the shape you are after. A piece that you spend the extra time shaping will show and stand the test of time. It is never a waste of time to do so.

Look at the top edge of the piece when doing the final shaping. It gives you a better sense of the true shape.

Work the piece as a whole when doing the final shaping. This allows you to see the complete form better.

Leave the piece in the chuck, but take it off the lathe, and look at the piece in the orientation it will be when finished.

When shaping start from the point you believe to be the largest diameter and work from there.

The Golden Mean (rectangle) can be used for developing proportions in your work. These proportions can be found in nature and the human body as well as in art and architecture dating back centuries. You can use this as a guide in developing these shapes.

Doing research on the elements and principals of design will give you a better understanding of the way we see objects and what is most pleasing to the viewer.

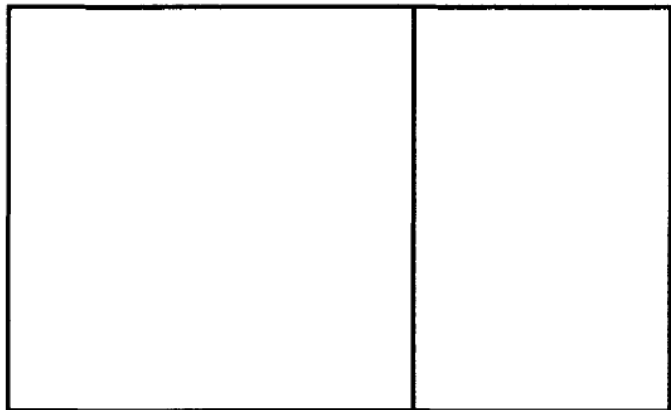

Conclusion

I hope this information gives you a starting point for creating your own unique turnings. As always, just have fun with your turning and it will show!



TURNING 26

WITH

JIM BOB BURGEOON



Between Centers Pens & Other Applications

TURNING PENS BETWEEN CENTERS

Materials needed:

- 60° dead center, carbide tipped
- 60° live center, carbide tipped
- Turn between centers bushings (TBC)
- Wet or dry sandpaper
- 3M Polishing paper or Micromesh
- Plastic polishing liquid, Meguires or Novus
- CA thin and medium
- Beall buff system
- Optional items:
- Disc sander or stationary belt sander
- Transfer punch set
- Aluminum v-block



Material Prep:

Cut blanks 1/8" longer than the brass tubes provided with the kit. Drill appropriate size hole, using a drill press equipped with a jig to hold the blank in the correct position. Scuff brass tubes with sandpaper prior to gluing. Some experts recommend plugging the ends of the tubes with wax or potato to prevent glue from getting on the inside of the tube. Apply medium ca or epoxy to the brass tube and insert it into the blank. Square both ends of blank to the brass tube. I prefer to disc sand, using the v-block and transfer punch, rather than using a barrel trimmer. Material prep instructions are included in most kit instructions. If your kit comes without instructions, they can be downloaded from supplier's sites.

TBC Bushings:

Turning Between Centers bushings differ from traditional pen bushings by having a 60° countersink on the end. This countersink matches the cone angle on the dead and live centers. A recent product which has come on the market is adapter bushings. These bushings can be inserted into the ends of traditional pen bushings to transform them into TBC bushings!



Turning:

Insert the appropriate TBC bushings into the ends of the blank. The dead center is the drive center and should be installed into the headstock. The live center goes in the tailstock. Mount the blank between centers and turn. I will generally finish turning with a negative rake scraper to fine tune the shape. I turn much closer to the bushing using TBC techniques than turning on a mandrel, thus reducing sanding time.



Sanding for CA finish:

Slow the lathe speed down for sanding. Sand the blank with 150, 220 grits. The goal is to be even with the bushings when finished with 220. Remove the bushings and return the blank between centers. You only need enough tailstock pressure to drive the blank during the remaining sanding process. Continue sanding with 320, 400. Remove the blank, reinsert the bushings on each end to assure the amount of material removed is equivalent to a thickness of a sheet of paper below the bushings. Remove the bushings and remount the blank between centers. Sand through 600, 800, 1200 grits, and burnish with brown paper.



Finishing with CA:

This process is what works for me. There are other procedures that work! Prep paper towels (any brand will work) by making a doubled 1" x 1" along with a 1/3 sheet folded multiple times. Cover the ways of the lathe with a board for protection. Apply accelerator on the 1x1 and wipe over the blank with the lathe running slowly (1000 rpm or less). Apply 2 coats of thin CA by applying the CA to the folded paper towel, then wiping from one end of the blank to the other. Reapply accelerator between coats. There is no need to reapply accelerator to the 1x1 each time you wipe the over the blank. The residual accelerator in the paper is usually sufficient to cure the CA. If CA dry times get extended, refresh the 1x1 with accelerator. Remaining coats of CA will be medium viscosity. Apply CA by dribbling from the top with the



folded paper towel following on the underneath side of the blank. Wait 2 minutes before applying next coat of accelerator and finish. Repeat process until finish is higher than the bushings. 7 coats are generally sufficient, but that is determined by how much the blank was under sanded below the bushings. The CA will extend beyond the end of the tubes. Trim it back flush with the ends of the tubes. Replace bushings and mount between centers. All sanding is wetsanding from this point on. Begin with 320 to remove the ridges from the finish. Follow with 400 grit, to bring finish to level with bushings. Follow with polishing paper or micromesh, to highest grit. Apply plastic polishing liquid. Remove polishing liquid and remove from lathe. Buff blank using Beall buff system with the Tripoli and White Diamond wheels. Assemble components.

MAKING TBC BUSHINGS FROM ORDINARY BUSHINGS

Materials:

4 jaw chuck with pin jaws
 Jacobs chuck on morse taper shaft
 Center drill
 Cutting oil



Procedure:

This process works for all bushings except slimline. Mount 4 jaw chuck onto headstock. Insert the small end of the bushing into the 4 jaw chuck. Insert center drill into Jacobs chuck and mount in tailstock. Bring tailstock up until center drill is almost touching the bushing. Lock tailstock down. Apply cutting oil to center drill. With the lathe running on the slowest speed, advance the center drill into the bushing slowly. Repeat for other bushing.

SOURCES

Centers – zlivecenter.com
 TBC Bushings
 The Classic Nib <http://www.classicnib.com/between-center-steel-bushings>
 Lazerlinez <https://www.lazerlinez.com/products.php?cat=25&pg=2>
 Beartoothwoods http://www.beartoothwoods.com/catalog/index.php?cPath=35_37
 3M polishing paper
 The Sanding Glove <http://thesandingglove.com/3M-WetOrDry-Polishing-Papers.asp>
 Transfer punch set – Harbor Freight
 Aluminum v-block
http://www.beartoothwoods.com/catalog/product_info.php?cPath=35_41&products_id=2709

ADDITIONAL INFORMATION

http://content.penturners.org/library/techniques/turn_between_centers.pdf



TURNING 26 WITH LES CASTEEL



Turning Old & Antique Wood Pulleys

INTRODUCTION

Wood items have been used in various ways to decorate our homes, businesses and outdoor spaces for many years. Wooden pulleys designed for industrial use in times past, are becoming very popular today, as functional, decorative art. A new-old wooden pulley is suitable for use in a light duty situation such as hanging a light fixture, plant, or some form of lighting.

This demonstration will provide ideas on designing and building a new, "ancient" pulley. I will touch on repairing your favorite old ones. We will begin briefly with a history of pulleys, and they're usage through the ages. We will then discuss the various parts of a wooden pulley such as the wheel, shaft, frame, hook, and rope. Examples of both antiques and new re-creations, will be shown and discussed. I will demonstrate how to safely, turn pulley wheels and shafts. Methods for creating a suitable frame will be explained and demonstrated as well as fitting the pulley into its wooden body.

Finally, techniques for "aging" the turnings both wood and metal will be discussed and demonstrated. This technique makes a new creation appear to be very old and used.

WHAT IS A PULLEY?

A pulley is a supported wheel with a groove (cove), along its edge, which is used for holding a rope or cable. It is a simple machine that changes the direction of a pulling force. Pulleys in the "non-decorative" world, are usually used in sets (called a "block & tackle"). This allows for the reduction of the amount of force needed to lift a load,

HISTORY OF THE PULLEY

As is the case with all the simple machines, the origin of the pulley is unknown. Early people lifted heavy objects by throwing vines or other crude ropes over tree limbs. This essentially is the same as using a single fixed pulley to change the direction of a force.

The wheeled pulley was an advancement on the technology of the time that allowed great weights to be lifted with little force. Although nobody can say for certain when or where the pulley was invented. There is evidence of use all over the Mediterranean and in Egypt as well. The Greeks can claim credit for the earliest known written mention of such a device, in a text from the 4th century B.C., as recorded by Plutarch. Plutarch describes how Archimedes used a system of compound pulleys to enable himself to move a three-masted merchant ship that had been placed on dry land and then loaded down with passengers and freight. Archimedes is supposed to have made his famous remark, that he could move the entire earth if given the right place to stand.

PARTS OF A PULLEY

FRAME: Often called a BLOCK, BODY, SHELL, or HUB. It is the wood and/or steel structure that holds all the working parts. The top of the FRAME is called the CROWN. The bottom is called the TAIL.

On early ships near America, or the upper Eastern Atlantic, the wood used was often Elm or Oak. The wood used for construction varied drastically in other parts of the world, but was normally any tough, durable, easily obtained hardwood.

WHEEL: or STROP-WHEEL. The WHEEL will have a ROPE or LINE on it. The RIM, is the perimeter of the WHEEL where the GROOVE, or SHEAVE, is located. (woodturners would call it a COVE). In early times the WHEEL was made from soft metals, wood, or stone. Later it was made from Iron or Steel. The holes that exist between the WHEEL and the FRAME on top are called SWALLOWS. The holes on the bottom of the WHEEL and the FRAME are called the BREECH.

PIN: The AXLE, PIN or SHAFT "contains" the WHEEL in place on the FRAME. In early times it was manufactured from bone, metals such as bronze or copper, and later iron. And of course turned wood.

STROP: The ROPE or LINE that lays on the wheel

HOOK: The hook is attached to the top of the pulley.

THIMBLE: The hook or ring attached to the bottom of the FRAME.

DESIGNING PULLEYS

There are no definitive set of steps that come into play when designing a wooden pulley. But there are some thoughts.

1. Define the purpose for the pulley.
How much weight will it hold?
What wood will be used?
What finish should you apply?
2. Where/How will it be installed?
Determine the location, outside or inside?
What hardware is needed to safely support it?
Think safety....will it be too low...too high?...is it sturdy?
Will you need to move it due to seasonal change?
Do you want this to be a focal point or functional only?
3. Scale/size? big, small, brightly colored, or un-assuming?
4. Finish? UV protection, color or stain, authenticity, rusty iron old or new look, type of rope or cord for the wheel

BUILDING A 18TH CENTURY SHIP'S PULLEY

The 18th century common ship's pulley is easy to construct, it is scalable and always welcome!

STEPS:

1. Study the guidelines for designing a pulley (above).
2. The pulley generally looks more authentic if the wood is all the same thickness. I used 1" thick wood for the example. Cut 3 pieces of wood into the following sizes:
 - (2) 3 1/2" wide x 7" long
 - (1) 3 1/2" wide x 3" long
3. Stack the two 7" pieces on top of each other and tape them together with painter's tape on one end. On the other end cut a 1 3/4" arc, with a bandsaw, and sand if desired (rustic "not sanded, or smooth, your choice).
4. Decide what material you will use for the wheel pin. Generally, this pulley is more "authentic" if a steel bolt is used as a wheel pin. However, this is your project, so of course you could use a wooden turned pin! The diameter of the hole you drill next depends on which you use, the diameter of the bolt, or the diameter of the turned pin. Make a mark down the center of one of the 7" boards on the lower half (the end where you cut the arc).

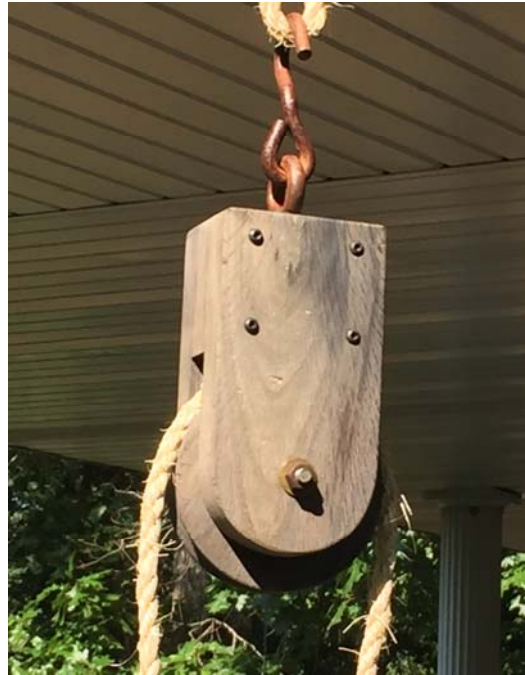

Measuring from the end where you cut the arc, cross the center mark 1 1/2" from the arc. This should locate the pin hole for drilling. Stack the two boards together and drill the hole through both boards.

5. Put some glue on both faces of the small board and sandwich it between the 7" boards. Make certain the small board is flush with the square end of the 7" boards. This should leave a place to install a wheel later at the opposite end where you cut the arc and drilled the hole for the pin. Clamp the 3 boards and let the glue cure.
6. Cut a board 4 1/2" square. This is your wheel blank. It should be the same or slightly less thick than the middle board. Draw lines from corner to corner to achieve a mark that is in the middle of the square. Repeat on the opposite side. Use an awl and tap in a shallow hole on both sides where the lines cross. Mount this onto your lathe. I would suggest a stebcenter on the headstock end, and a normal point on the tail stock end. Tighten it up and spin it slowly. You will see a circle appear, and you can use a pencil to mark it on one side. Remove the wheel blank, and bandsaw off the corners. Do not touch the lines!

Remount and use whatever tool you are comfortable with to square up the edge. Once it is square, use either a spindle gouge or scraper to turn a cove in the center of the wheel about 3/8" deep. Check your rope to see if it lays in the cove. (I recommend 3/8" sisal rope as it looks authentic) Do not sand the cove. Remove the wheel and check to see if it fits into the frame of the pulley. If so drill a hole in the middle of the wheel. It should be the diameter of the bolt or the pin that you've turned. Tidy up by sanding the wheel on both sides and the corners of the cove gently. Remove the wheel and check to see if it fits in the pulley body. You should be able to slide it in and out easily, as well as seeing the center holes lined up. When all is well apply finish of your choice to the wheel.

2107 SWAT

7. When the glue on the body pieces have cured, sand the body lightly to remove any excess glue. Check inside and remove any glue with a chisel or sand paper. Sand the flush end gently. At this time you could distress the body, to make it appear that it has been heavily used. You could also install round head screws, square nails, bolts or whatever you choose to make it appear that they are securing the body for heavy use.
8. I purchase 1/4" diameter screws that are already attached to 1/4" eyebolts. These are available at hardware stores. The eyebolts have threads like a screw.

With the top of the pulley's body up, use the corners to determine the center point of the body. Mark the center with an awl. Use whatever drill bit is needed to drill a pilot hole for the eyebolt screw. Screw in the hook & eyebolt into the body. Make sure the eyebolt does not protrude into the wheel notch. Apply finish to the body. If you decide to alter the hook and make it look rusty, do that before you install it.

9. Slide in the wheel and install either the wooden pin you turned or a bolt. Usually, a wooden pin is turned to be a friction fit and tapped into place. The bolt would most likely be secured with a nut and washer.
10. Hang the pulley and insert the rope through the swallows and test the wheel. Its okay if its tight but with slight downward pressure the wheel should turn. If not, remove the wheel and sand it a bit on both sides making it thinner.



TURNING 26 **WITH ANDY COLE**



Hawaiian Calabash Bowl

One of the most recognized shapes in wood bowls today is the Hawaiian Calabash. The shape itself is pleasing and is one that anyone would be proud to own. In this demonstration we will cover the process from blank selection to finished bowl.

We will first start with a bowl blank with a diameter about twice the thickness. After examining the blank we will determine the best side to be the top (or bottom). Once on the lathe we will determine the basic shape using a bowl gouge and cut a tenon on the bottom for holding in a four jaw chuck.

After the basic shape is determined the blank will be secured in the chuck to fine tune the outside shape and clean up any gouge marks on the outside. The next step is to begin the process of cutting out the inside of the bowl. Calabash bowls are often very thin walled so we will start by thinning the upper portions first and then proceeding to work our way to the bottom. This is very important as the walls may begin to warp and will become less stable as the bottom gets thinned. We will use a variety of gouges and scrapers to get the optimum cuts along the way. Chatter can become a problem when the bowl gets thin so careful attention will be given to minimize this problem.

Once the bowl is cut to its final thickness it will be sanded to 600 grit in order to achieve the smoothest possible finish. Attention will be given to any problem areas that need attention or additional sanding.

With the bowl nearly complete it will be time to determine the best way to finish the bottom. We will examine the shape and thickness of the bowl bottom to determine if it will be given a foot or be made flat. Since perfectly flat may not be the best option we will opt for either slightly concave so it sits flat or give it a rounded bottom and let it rock a little. Various chucking methods will be discussed and demonstrated.

The final phase will be to oil the bowl and buff using the Beall system, which will give the piece a glassy smooth finish.



TURNING 26 WITH ANDY COLE



Natural Edge Nested Sets

One thing better than turning a beautiful natural edge bowl is to convert the inside into a nested set rather than a pile of shavings.

There are several types of coring systems on the market today, but the Kelton (aka Kel McNaughton) system is probably the most versatile. It is also one of the toughest to master, but the range of shapes that can be removed makes the system worth learning how to use. Many people have attempted to use this system and encountered much frustration in the process. During my demonstration I will address many of those problems.

The basic process of turning a natural edge nested set starts with blank selection. I always work with green wood with bark firmly attached. For those who live in Northern climates, wood cut later in the season (Fall) tends to work best.

After cutting the blank to a round shape on the band saw it is important to saturate any cavities in the bark with very thin viscosity CA glue. This will help to keep the bark in place once the coring process begins.

The next step is to shape the outside of the bowl as if you were going to make a single natural edge bowl. It is very important to leave room for a large tenon on the bottom of the bowl for chucking. The coring process involves very high levels of intermittent resistance as the blades are entering the wood. It is really easy to break the bowl free from the tenon with a catch while coring. On a 16" diameter bowl it is important to leave a tenon about 6" in diameter to assure a good hold.

Once the outside of the bowl is shaped, you are ready to begin the coring process. I always start my cuts with the straight blade as this gives much greater control and minimizes the possibility of accidentally nicking the bark during tool entry and extraction. It is best to start your cuts at the outside about 1" from the edge of the largest bowl. You can go in with the straight blade until it becomes obvious that a curved blade is needed to round your way in. The re-application of CA glue throughout the coring cuts on the bark areas will help to assure that fewer pieces of bark come flying off.

After making your first cut on the outer most bowl with the straight blade you can progress your way into the next bowl. The number of bowls that can be extracted depends on a number of factors. The diameter of the bowl will make things pretty obvious as you make your way to the center and run out of space. It is also important to keep in mind the depth of the bowl as a shallow bowl will not allow as many cored pieces due to the lack of wood on the bottoms.

Once all initial cuts are made with the straight blade you can switch to using the curved blades. It will take some experimentation to learn which radius blades work for each size. Practice on junk wood before attempting to work on the good stuff. You will most likely wreck a few before becoming a master. Just remember that any accident you can walk away from unharmed is a good learning experience!



TURNING 26 WITH ANDY COLE



Sunny-side Up Egg on a Platter

Ingredients needed:

- Yellow wood such as Osage Orange (2x2 end grain stock)
- Light colored wood such as Maple (6x6x1)
- Dark colored wood for plate (10x10x1 walnut or cherry work well)

Turning the yolk:

- Turn a dome shape about 1 ¾" in diameter which will be the top of egg yolk
- Cut a slight inward taper on side about 1/8" deep to fit in the egg white
- Finish with friction polish and part off with slight hollow recess on underside

Shaping and turning the egg white:

- Select location for egg yolk (off center, but at least 2 ¼" from outside edge)
- Cut tenon channel (at bottom of yolk area) ½" wide x ¼" deep for chuck jaws
- Note: tenon must be slightly larger than diameter of yolk
- Grip blank by tenon and reduce thickness to about ½"
- Drill ¼" release hole in center of egg white (optional)
- Sand center area slightly and draw template circle the size of egg yolk
- Carefully cut recess to hold egg yolk being careful not to cut too large
- Remove egg white wood from lathe and draw creative shape for finished egg
- Cut basic shape on band saw
- Remount on lathe and taper to 1/16" on outer most edge
- Note: only the outermost tip of white will be nice and thin
- Shape white to 1/16" on outer perimeter using sanding discs or rotary burrs
- Power and hand sand as needed to achieve silky smooth egg white

Turning the plate

- Cut tenon on what will be the top of plate and mount in chuck
- Shape bottom including expansion grip recess
- Sand and finish all bottom areas of plate
- Reverse plate and hold by bottom to finish top of plate
- Use finished egg white to get proper size and fit on inside of plate
- Finish components and season to taste!

Alternate method:

- Go to kitchen and start with small frying pan on the stove



TURNING 26

WITH JEANNE DOUPHRATE



Curves in All the Right Places: *Designing Attractive Forms*

“In design very small differences make all the difference. The difference between the thing which sings and the thing which is forever silent is often very slight indeed.”
-David Pye

Whether making pens, bowls, balusters, ice cream scoop handles, or art, the key element that separates the good from the great is form. When I was a new turner, I asked my club president how long he had been turning. He replied, “Over 30 years”. I was awestruck, and remarked, “You must be able to turn just about anything on the lathe!”. He humbly responded, “Yes, I guess so. I just don’t know how to make it look pretty.” This comment struck me like a thunderbolt and has driven me to discover the secrets of making woodturnings “look pretty”. The professionals say that recognizing good form should be intuitive. However, like learning a new language, for most people, it is not intuitive at first. Just like any other skill, developing an eye for form takes study and practice. I don’t claim to have mastered it yet, but I would like to share the lessons that have accelerated my success at the lathe over the past few years.

Get Familiar with Good Form

- Look around the produce section of the grocery store for interesting and attractive shapes.
- On a walk, inspect the contour of leaves, plants, and flowers.
- Go to museums or look on-line for classical forms, which have stood the test of time.
- Be inspired by what professional woodturners are doing (but resist the temptation of copying if you plan to sell or exhibit your work).
- Take a look at professional work in other craft media, such as glass, ceramics, basketry, and fiber arts.
- Make a series of small forms and paint them white or black. Take time to consider which is best and why.



Lines/Curves

- Imperfections in form can’t be hidden by embellishments, any more than imperfections in form can be hidden by a bikini.
- Abrupt changes in direction and flat spots can be a “turn off”. The eye loses interest and moves to look at other things.

2107 SWAT

- No matter the embellishments added to your piece, always start with good form. The eye will connect the dots along the surface to “read” the original form.

Proportion

- When in doubt, use the Golden Ratio or Fibonacci Sequence. These proportions are known to be universally eye appealing.
- Trim blanks to the desired height and width before turning. Maximizing size to minimize waste does not increase your chances of turning an attractive form.
- When turning bowls and vessels, the inside curve should compliment the outside curve. Don't be afraid to cut a bowl or vessel in half, once in a while. This will help improve your forms!
- Be aware of what is happening in the negative space.

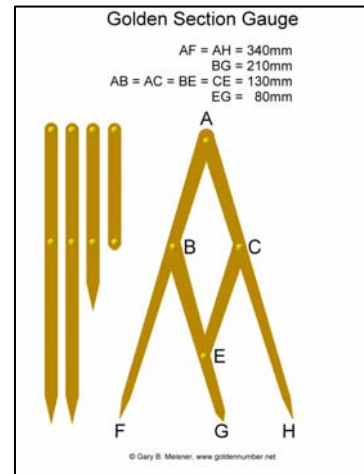

Rim

- Consider proportion of the rim in relation to the proportion of the foot. Fibonacci calipers can be helpful.
- Curved surfaces are generally more appealing than flat surfaces to both the eyes and the hands.
- Natural and asymmetrical rims can add dramatic visual interest to simple forms.
- Done right, the rim can lead the eye toward a desired focal point.

Foot

- Every woman knows she'll turn more heads in high heels than tennis shoes. Vessels and bowls that have an appearance of “floating” are particularly eye appealing.
- A woman who falls down while wearing high heels turns heads for the wrong reason. The foot of should elevate the piece to look its best, while being both elegant and supportive.

Practical Tools and Tricks

- Fibonacci Calipers
- Golden Rectangle
- French Curves
- Graph paper and mirror
- String and pin, or trammel bar
- Chains for catenary curves
- Flexible plastic rods
- Storyboards
- Squint method
- Maquettes
- Computer aided design



Squint Method

Good form is always the basis for successful work. Learning to recognize good forms is like learning to read a language. Learning to make good forms is like learning to speak it. Guidelines and tools are the dictionary of this language. After much study and practice, fluency is achieved, and reliance on tools and tricks will disappear. Form becomes an intuitive part of the making process.

Bendable Compressed Hardwoods

Time permitting, Jeanne Douprhate will also discuss the use of bendable compressed hardwoods to add handles and other sculptural elements to turned objects.

Cold-Bend Hardwoods™ are straight-grained woods, such as Maple, Walnut and Beech, that have been through a special steaming and compression process. No chemicals are used in this process. Compressed wood can be cut, carved, turned, dyed, stained, burned, finished, joined, glued, etc., like any other wood.



On a cellular level, compressed wood has accordion folds, similar to a “bendy” straw. This allows the wood to bend gently without splitting or breaking. When wet, compressed woods can be bent. When allowed to dry in the desired position, the shape is retained.



*Gratitude
Jeanne Douprhate (2016)
Photo by Raleigh Mead*



Before Compression



After Compression

- Soaking in cold water will cause compressed wood to become bendable.
- Wood needs to be wet through the full diameter in order to bend. This may take minutes for small, thin pieces to hours or overnight for thicker pieces.
- Don't oversoak. Compressed wood will expand and lose its ability to bend.
- Compressed woods are less prone to breaking than other woods. This makes them ideal for thin and delicate work. Jeanne has dropped numerous carved pieces without breaking them!
- Thick pieces are difficult to bend, and may require a jig.
- Long pieces may flex on the lathe, causing chatter.
- Long pieces may experience slight drift over time.
- Compressed hardwoods can be purchased from Pure Timber LLC, <http://www.puretimber.com/>.

Recommended Reading:

Cummings, Frank E. III (1991, December). Design – A practical approach. *American Woodturner*. 6(4), 2-5.

Ellsworth, David (2008). *Ellsworth on woodturning: How a master creates bowls, pots and vessels*. East Petersburg, PA: Fox Chapel Publishing.

Hayes, Derek (2011). *Woodturning Design*. Newtown, CT: The Taunton Press.

Holzapfel, Michelle (1995, December). Getting a feeling for form: Seeing is believing, but touching is knowing. *American Woodturner*. 10(4), 34-37.

Huntley, H. E. (1970). *A Divine Proportion: A study in mathematical beauty*. Courier Corporation.

Key, Ray (2001, Summer). From...Design thoughts. *American Woodturner*. 16(2), 13.

Patterson, Freeman (2004). *Photography and the Art of Seeing*. Toronto, ON: Key Porter Books.

Pye, David (1968). *The Nature and Art of Workmanship*. New York, NY: Bloomsbury Academic.

Raffan, Richard (1987). *Turned-Bowl Design*. Newtown, CT: The Taunton Press.

Sing, Dick (2000, Winter). Pitfalls for beginners: Crawl before you walk—Learn the basics. *American Woodturner*. 15(4), 40-41.



TURNING 26

WITH JAMES DUXBURY



Illusions - Unique Decorative Four Center Turning

Illusions – This unique decorative four center turning creates a spatial third dimension, revealing depth as the lighting and viewing angle change. This basic design allows for much more complicated and fascinating possibilities. Designs can be the same cuts on both sides, just offset as shown here, or a more complicated design can be achieved with 12 or more centers involved. The pieces are drawn first to get precision and accuracy.

The square stock piece is mounted on a flat faceplate with two screws seated at opposite corners. The piece starts out mounted on center, dished down and sanded on both sides leaving about a 3/8" thickness in the center. Bring the tailstock up and mark the center.

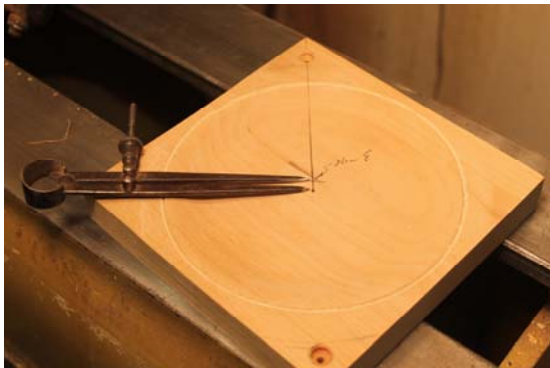

The piece is then removed from the lathe. Draw a line from one corner to the center of the piece. Then from the design drawing locate the new offset center.

Remount the piece on the face plate using the new center.



2107 SWAT

Remember to offset the piece center on the other side in the opposite direction and be very careful making the final cuts. The rings are very delicate and not real strong. From here remove the piece, trim off corners with screw holes, final sand and finish as desired.



A completed four center piece



TURNING 26 WITH JAMES DUXBURY



Traditional Kaleidoscopes

HISTORY OF KALEIDOSCOPES

Sir David Brewster (Dec. 11, 1781 - Feb. 10, 1868) was Scottish born. At a young age he was recognized as an outstanding scholar who was admitted for the study of ministry at the University of Edinburgh at the age of 13. Although he did not complete the prescribed degree, he was awarded an honorary MA and was licensed to preach in the Church of Scotland. Even though Brewster was never ordained a minister, he became a very devout evangelical Presbyterian.

He believed in the unity of truth and felt that such unbridled speculation in physics had profoundly serious implications for religion. To him, "speculation engendered doubt, and doubt is frequently the parent of apathy or impiety." He was a brilliant mathematician and experimenter in astronomy, polarization of light and spectroscopy, but had a conflict with theories that required him to abandon his deep convictions about man's ability to know the world and man's duty to God.

The University training prepared Brewster as a skillful writer and editor, which became the main source of income throughout his lifetime. Shortly after his career on the pulpit, he turned his studies and interests to optics although his income depended on his literary, rather than his scientific efforts. Brewster built sundials, microscopes, and telescopes and later, the stereoscope. His reputation on the popular level was established with his invention of the kaleidoscope in 1816 while experimenting with prisms and other optical tools.

During the early 1870's, **Charles Green Bush** began developing kaleidoscopes in the United States. His parlor type scopes of 1873 were the trendsetters of that era and very profitable for Bush. These scopes are sought after as collectors' items even today. **Cozy Baker**, 'First Lady of Kaleidoscopes,' founded the Brewster Society in 1986 to provide communications among artists, designers, retailers, collectors, and lovers of kaleidoscopes throughout the world. In recent years, the kaleidoscope has again renewed popularity as an object of interest to collectors and those who simply appreciate the beauty and creative array of its many designs.

WHAT'S INSIDE A KALEIDOSCOPE

The interior of a kaleidoscope can consist of 2,3,4 or more first-surface mirrors that run full-length of the inside of the scope. The angles of the mirrors will determine the number of reflections viewed. (Smaller angle = More reflections of object viewed.)

The quantity of mirrors determines the shape and style of the image seen. A two-mirror system will make a cathedral window or mandala-like image (circular design of geometric forms). There are no side reflections, only a single circular pattern. A three-mirror set will reflect the pattern throughout the inside of the scope. A four-mirror system will result in either a series of rectangular images, or a symmetry pattern that has a double center point.

A teleidoscope is exactly the same as a kaleidoscope except that the object case is a lens. The lens will show whatever you are pointing the scope at around you and the mirrors will reflect that image. Sometimes a plain glass or crystal ball is used as the lens.

2107 SWAT

This tube-like instrument containing mirrors set at different angles to reflect the image of loose pieces of glass and various other colorful objects created symmetrical patterns when viewed through the eyepiece of the tube.

Thousands of these devices were sold as toys or instruments of amusement in London and Paris within the first few months. Sir David Brewster was immediately delighted with his fascinating device and named it using the Greek words:

kalos (beautiful) +
eidos (form) +
scopos (watcher) =

**KALEIDOSCOPE:
THE BEAUTIFUL FORM-WATCHER.**

TURNING HOLLOW GLUED UP FORMS

This is a fast, low cost way to turn a hollow centerless staved type cylinder

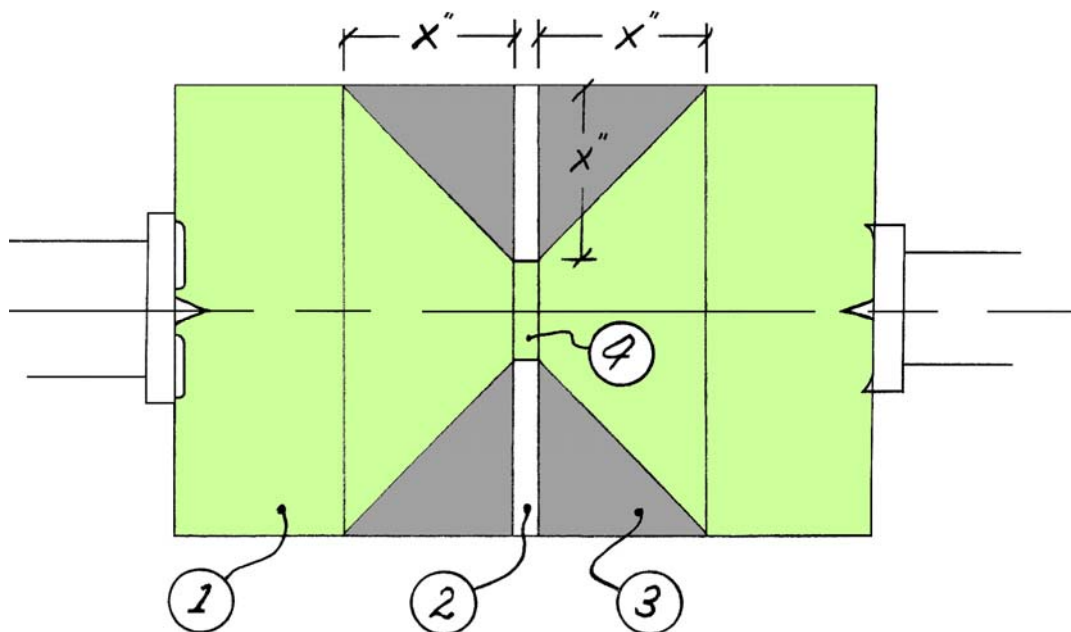

1. Select a block about 1" larger than the hollow center opening and about 3" long.
2. Mount block between regular spindle centers.
3. Turn blank round.
4. Part in the center down about 75% of the way (Cut #2)
5. Mark the depth of that cut on both sides of it. (X")
6. Remove the stock forming a V. (Cut #3)
7. Part in center and catch both #1 pieces (Cut #4)

KALEIDOSCOPE DEMONSTRATION HANDOUT

For Reference Only

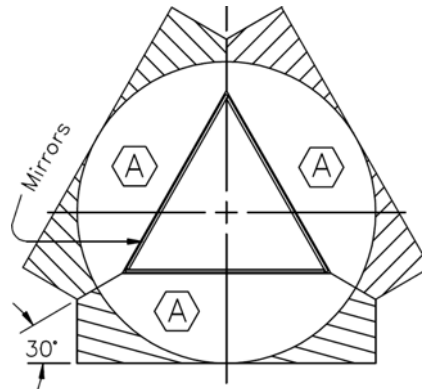

Figure 1

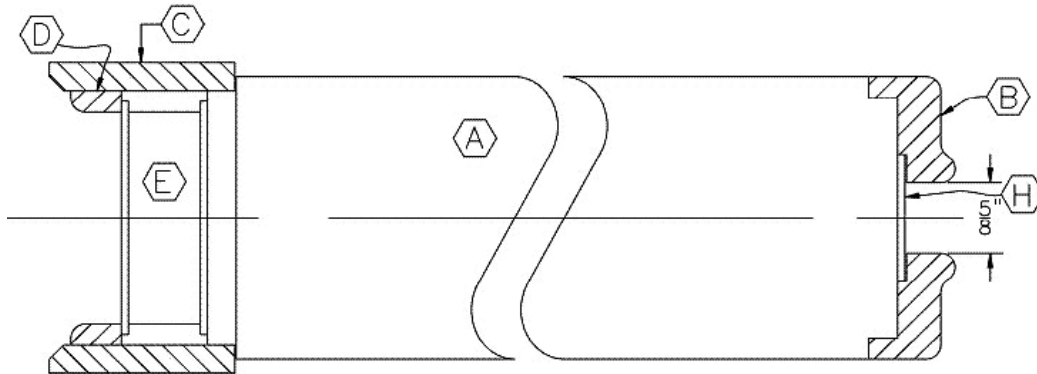

Figure 2

- A Main Barrel, houses the reflective mirrors.
- B End Cap, seals the end with an eye hole opening for viewing.
- C Rotating Barrel, houses the object box.
- D Retainer Ring, holds the object box in place.
- E Object Box, contains the colorful objects to be viewed.
- H Eye Piece, protects user's eye if mirrors get broken and seals opening from dust.





TURNING 26 WITH LINDA FERBER



Make a Button Cylinder Pendant

My father and grandfather, both woodworkers, were the key influences in nurturing my interest in the art of working with wood. I have been using the lathe to transform nature's gift of wood into new forms for fifteen years, I enjoy the creative process and the challenges of expressing an idea or vision through a turned piece of wood. My work uses simple lines and allows the viewer to discover the meaning for themselves.

Utilizing the simple, yet elegant, cylinder shape, a person at any woodturning skill level can create a unique version of this button cylinder pendant. Woodturning is a 3D art and a cylinder is one of the first items a turner learns how to create on a lathe. I used basic cylinder shapes in this project and incorporated off-center techniques in a manner different than most eccentric turning. I invite you to work on design details with the thought that simplicity does not occur without consideration. This project emphasizes that successful simplicity does not just happen; it comes with clean lines and precision.

Equipment used:

- Spindle roughing gauge
- Skew chisel
- Detail gouge
- EEE Ultra Shine paste wax
- Pen turning jaws
- Blue tape
- Abrasives
- Jacobs chuck
- Eye screw
- Necklace chain
- PPE: latex gloves, facemask, respirator/dust mask

choice. Normally I don't like shiny finishes, but with this project I prefer the highly polished presentation on pieces of burl

Selecting the wood

Pen blanks are a perfect fit to use to start this project. The bonus is you are able to get two pendants from each blank. Also, those small pieces of expensive, or highly figured woods left over from previous projects but too good to throw away, are potential resources for this project. Of course, any plain wood can be used as a canvas or to add a small decorated accent to the work. The design is meant to be straightforward and simple, so this is an opportunity for the wood to be the main feature. When selecting the blank stock, examine the grain of the wood - grain running the length of the piece or at an angle will be best for turning. A piece of burl is an excellent

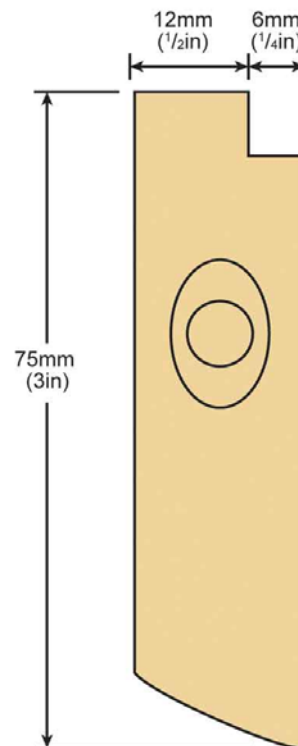

2107 SWAT

STEP 1

After selecting your wood stock, set up the lathe for traditional spindle turning. Start by using a spindle roughing gouge to make quick work of turning the cylinder. When turning the cylinder shape, watch the horizon to get a true line. Crisp, clean lines are essential to the final look of the piece.



STEP 2

With the lathe still in this setup, finish sand the cylinder to at least 800 grit. The finish is critical for a jewelry project. All tool or sanding marks must be removed. The EEE Ultra Shine paste wax is useful to create a nice shine if an exotic wood is used.



STEP 3

After turning and sanding the cylinder, set up your chuck with extended pen turning jaws. They allow a longer reach for the piece and give you the ability to place the piece at an angle to create an interesting turned button - bead. Turn the cylinder over, looking for the side you think will look best in the front and select the most interesting side. The placement of the button position is important to the finished design. I prefer the button higher on the piece more towards the top, roughly following the golden rule of one-third and two-thirds on the bottom. To set up the angle, use blue tape placed on two sides of the cylinder, leaving the desired front open.



STEP 4

This offers protection from jaw marks. You can then select a top and a bottom. The area you will turn is in the centre of the jaws, so place the top of the piece flush with the top of the jaws, angling out the bottom of the cylinder towards you.



STEP 5

Here is the piece mounted and viewed from the side.



STEP 6

When the piece is set up, the results will be a turned button that has a longer swoop - or plunge - at the bottom, which helps to add an interesting detail. Before you turn on the lathe, always test to make sure the wood is secure in the jaws. While turning, the gouge should be in the same position as you use for turning a bead. Start with the flute up and end with the flute on the side.



STEP 7

The button - bead - can vary in size and diameter. When making a narrow or wide bead shape, always ensure to check depth: too deep and the bottom overpowers the cylinder; too shallow and the proportions are off. When you've finished turning with the detail gouge, turn a small detail at the bottom of the button using a skew chisel. Smooth up the edges with abrasives when necessary. Inspect to make sure no tool marks are showing and sand as needed - with the lathe switched off.



STEP 8

Now set the button back up for spindle turning in the same exact position as your first spindle set up. You should inspect and fix any imperfections that you find. Then, proceed to sand, starting at about 400 grit, then use the paste wax to put on a finish.



STEP 9

The next step is to set up to turn the offset accent by positioning the top of the pendant so that the button is a little higher on the piece. If looking at the tailstock, move the piece of wood one centre point width away from you to create the off-center accent.



STEP 10

You can then begin to turn the off-center accent at the top of the pendant. Then, using a skew chisel, turn the top off-center accent piece.



STEP 11

In this photo, you can clearly see the offset turned cut.



STEP 12

Clean up the top edge with a skew chisel slicing cut and on the bottom, make a clean slice, also using the skew. These cuts take off the wood where the live centre has left marks. Then, shape the top and bottom. Change the setup of the lathe, putting a Jacobs chuck into the headstock and with a sanding pad inserted into the Jacobs chuck. You could also use the drill press with a sanding pad or a belt sander. Sand and shape the top to be flat, leaving one slight indent in the centre as a mark for the next step. I like an angle to add interest, which also provides the person wearing the piece with a place to handle.



STEP 13

You now need to fit an eye screw on top of the cylinder. Correct proportions in selecting an eye screw size is critical here: too large or small will quickly spoil the look of the piece, as will its position. Test fit in a scrap piece of wood before drilling into your piece. Once drilled to suit the eye screw selected, apply adhesive to the eye screw and fix in place. Pliers are handy here and will help to hold the eye screw in place.

STEP 14

Decide on the desired drop distance from the neck the pendant will hang and choose a chain that will best suit the wood, the size and design characteristics of the piece. The finished pendant should look something like this

Handy Hints

1. Pay attention to details, especially when working on a small project.
2. Using your four-jaw chuck in a non-traditional way, think outside the box with everyday tools and accessories.
3. Have fun and do not worry about the items that do not work out.
4. It has been said hundreds of times, but make a half dozen or more of items such as this – that is the best way to learn. I find the small refinements you make to the project really matter and ultimately, make you a better turner.
5. This is a project that is an exercise in simple lines. Use your imagination to modify the shape and accent features. Enjoy the process and the results you create. As always, a simple project takes many steps, but I believe it to be true that the simple subtle shapes exhibit an infinite amount of precision and planning to achieve.





TURNING 26 **WITH JOE FLEMING**



The Airbrush Demystified and **Airbrush Art -** **How to Successfully Transfer Images**

Session #1: Airbrushing Demystified

In this session, I will focus on the basics of airbrushing. The main topics will be:

1. Airbrushing equipment and accessories
2. Airbrush types and options
3. Wood selection and preparation
4. Training and educational resources
5. Paint and dye selection
6. Basic painting skills
7. Intermediate skills of perspective, shading and tinting
8. Considerations for transferring an image to your wooden project
9. Color blending for effect
10. Cosmic cloud technique
11. Cleaning and maintaining your airbrush

Why Airbrush?

Many turners wonder why anyone would want to add surface enhancements to their wooden art pieces. This is a fair question and one with many answers. First, I select wood for the effect that it will provide in the final piece. I consider grain type (open or closed cell), grain orientation, grain pattern/figure, and wood color when designing a piece. If I am making a utilitarian piece, I rarely color or carve because I live the simplicity of the form for the function. If I am turning an art piece from an exotic wood, or a highly-figured wood, again, I usually let the wood stand on its own without additional enhancement. Too much enhancement can be worse than a bland piece of wood.

Session #2: Airbrush Art – How to Successfully Transfer and Paint Images on Your Project

In this session, I will present the tools and techniques to transfer an image to a wooden project, then paint it using the airbrush. Discussion will include:

1. Recommended supplies needed for image transfer
2. How to select the image
3. Preparation for transfer including color selection, tinting and shading, taping, and painting sequences
4. Painting a plate demo
5. Cleaning and maintaining your airbrush

If, however, I decide to color the wood, I want to control the effect to the maximum benefit of the final piece. The airbrush is my main choice of coloring tool because I can control the intensity of the colors, the placement of the colors, and the penetration of the material much more precisely than you can with a rag or bristle brush. Additionally, the choice of airbrush mediums available today offers the highest quality of material for art pieces.

What You Need: Required and Optional

Required for airbrushing:

- An airbrush
- Airbrush quality paint, ink or dye
- A regulated air source
- Something to color

Optional for airbrushing:

- Airbrush holder
- Masking materials
- Lacquer or other finish
- Stencils and pre-fab designs
- Drafting supplies
- Training videos
- Books and literature

There is a wealth of YouTube videos available and other materials. Keep in mind that there are 50 ways to accomplish everything, so you will find conflicting information.

A Few Definitions

Before diving into the coloring process, I will offer a few definitions:

- **Dye** – Dyes are colorants that are usually mixed in a solvent such as mineral spirits, oil, water or alcohol. Metal acid dyes are sometimes mixed with MEK or other “nasty” solvents. The dyes used in woodworking are actually very similar to those used for dyeing cloth and other materials. Dyes are characterized as transparent, as they bring about color changes in wood without obscuring the figure. The molecular size of the dye particles is so small they allow light to pass through virtually unhindered. In simple terms, the pigment in stain and paint is colored dirt ground up into small particles. Dyes are typically soluble salts or metals. Once mixed with their proper solvent, dye crystals dissociate into individual molecules, which are vastly smaller than ground up pigment particles. Thus, dye can get into spaces where pigment cannot.
- **Stain (Transparent Paint)** - Stains are really nothing more than very thin oil or water-based paints. Whereas dye stains are typically comprised of only dye and a carrier, stains are comprised of pigment, a carrier and a binder. Using a thin varnish (oil-based) or acrylic latex (water-based) as a binder, ground particles of natural and synthetic minerals are added to make stains. Stains should be stirred often to insure an even dispersion of pigment because the particles tend to settle on the bottom.
- **Airbrush** – An airbrush is a spray painting tool that uses compressed air to atomize the coloring medium and project it onto a surface in an even consistency. It is the smaller sibling to an air gun used by automotive and wood finishers.

Coloring Overview - Dyes

I primarily color wood in two ways. If I use dyes, my colors are bold and flowing. I usually select the colors for the complementary effect the color fields and overlap the dyed areas to create blended colors. Dye is a completely transparent medium. You can think of dye like colored filters for a camera. If you hold up blue and red filters together, you will see purple.

The issue is that the color of the wood will blend with the dye too. If you look at the majority of dyed pieces on the blog sites, you will almost never see a true blue or a true red piece. They

are almost always a shade of teal and orange, respectively. Wood tends to have yellow and red in it. Poplar has green. When I plan to dye a piece, I usually bleach it with two-part wood bleach. I apply the bleach three to five times to get the color out.

The other issue with dye is that it will penetrate end grain much more readily than side grain. This means that wipe-on dye will soak into the end grain and darken that color more than the side grain. When this happens, you will have a white-ish zone where the side grain is located.

You can see both the color shift and the “white ring of death” in these old photos (Figure 1 and Figure 2). Both are ash vessels. One is dyed with blue and one with red.



Figure 1: "Blue" dyed ash vessel



Figure 2: "Red" dyed ash vessel

Now, dye process is as follows:

- Sand to 180 or maybe 220 - no finer
- Wet the surface (raise the grain), then re-sand to last grit
- Bleach three to five times
- Seal with vinyl sanding sealer or lacquer
- Sand back the sealer
- Airbrush dye – do not soak the surface or you will get runs
- Seal with a light lacquer spray – not too wet or you will get runs, or reactivate the dye and cause it to run
- Apply additional lacquer coats to achieve build and desired gloss effect (Figure 3)



Figure 3: Figured maple vessels, dye and gloss lacquer

I refer to this whole process as the “Don Derry Finishing Technique” and I’ve documented it on my website – AirbrushingWood.com. He taught me how to build this type of finish. He learned it finishing electric guitars.

Coloring Overview – Transparent Paint

For the demonstration, I will be focusing on completing a piece using transparent paint and masking techniques. Transparent paint is really just stain. What that means is that if you apply enough of the material, it will become opaque. You can see the grain through the paint if you have not over-applied the paint to your project.



Figure 4: Oak platter, carved, burned and painted



Figure 5: Birch plate, painted

In the red oak piece (Figure 4), I used yellow, red, purple, blue and gray transparent paint. In the birch piece (Figure 5), I used transparent black, purple, blue and gray. As soft as the grain pattern is in the birch, you can still see it in all of these colors. The white is opaque paint and the grain is pretty well hidden.

With transparent paint, I am less concerned about the color of the wood because the paint will obscure the wood color so bleaching is not usually necessary.

Coloring With Transparent Paint – The Details

Here are the steps I generally follow when painting with transparent paint:

- Sand to 180 or maybe 220 - no finer
- Wet the surface (raise the grain), then re-sand to last grit
- Seal with sanding sealer or lacquer, if wood grain is fragile
- Sand back the sealer
- Layout the design directly on the wood or on the mask
- Cut the mask with a knife
- Lift mask and paint the selected areas in desired sequence
- Peel remaining mask
- Seal with a light lacquer spray – not too wet or you will get runs
- Apply additional lacquer coats to achieve build and desired gloss effect

Sanding:

When sanding for dye or paint, do not sand past 220 grit. Even 180 grit is fine. Why? Over sanding burnishes the wood fibers. Your sealers and paints will not have enough tooth to mechanically grip the surface and you can get a failure in the finish. Dyes will not penetrate as well.

What is more important is regular sanding patterns. On a vessel, if you are using a rotary sander, the sanding scratches need to be consistent over the entire surface. They do not need to be invisible. Optically, inconsistent scratch patterns are very noticeable under finish. Regular scratch patterns are not.

As part of my sanding protocol, I wet the surface of almost everything with a damp paper towel to raise the grain. Once dry, I sand to the last grit I used during the sanding process. Finishes can raise the grain. On a clear finish, you get the chance to sand it back and apply more finish. On a dyed or painted surface, sanding raised grain can damage the dye or paint treatment. Prevent the problem from occurring by raising the grain ahead of time.

Sealing:

I usually seal the wood surface with either vinyl sanding sealer or lacquer. This keeps dye penetration more even across end grain and side grain on a given piece. For paint, if the wood fibers are prone to lifting, the sealer hardens the surface. Once sealed, I sand back the sealer down to the wood.

Design Layout:

I have had very little success when trying to mask for dye. Dye is so runny, it will follow the wood grain and flow under the mask. My recommendation is to use dye for broad, flowing and overlapping colors.

If you are going to have painted and unpainted surfaces, you will need to mask the unpainted areas. You can use masking tape for this such as painter's tape. Try to avoid leaving the tape on the piece for too many days in a row or you could have tape residue issues. You can block large areas with paper scraps.

For the painted areas that are to have distinct colors, use frisket film to cover the whole areas and a sharp hobby knife to cut the color zones for painting.

For example, on Figure 4, the door and the bottom section were masked with tape and paper, as was the outside edge of the platter's rim. The colored area was painted from yellow to gray with no additional masking. The turned moon crescents were turned after the painting was complete.

On Figure 5, the rim was taped with flexible automotive masking tape and painter's masking tape, and then the entire inner portion of the plate was covered with frisket. Once covered, the entire image was transferred to the frisket using transfer/tracing/carbon paper. Next, the black areas were cut as one piece, the moon was cut as two pieces (small piece on the right side of the large cactus), and the sky as six pieces (large section on top, four small pieces next to the ground between the two cacti, and one small piece between the arms of the small cactus).

It is very important that you take care when cutting the frisket. Every cut line needs to intersect with adjacent cut lines. Failure to have the cuts meet will lead to stretching and tearing of the frisket which will show up in your painting. It is worthwhile to practice cutting. If you press too lightly, you will have stretching and tearing. If you press too hard, you can end up with deep cuts in your wood.

Painting:

Painting on Figure 4 was done in a five color sequence: Transparent yellow was sprayed for about the first two inches. Transparent red was sprayed from approximate one inch to about four inches. Transparent purple was next from about three inches to the top. Transparent blue from four inches to the top, and finally, transparent gray was sprayed from about five inches to the top. By overlapping the colors, I created oranges, magentas, and violet-blues.

Painting on Figure 5 was more elaborate. I carefully lifted the two moon frisket pieces and placed them on a clean piece of paper, sticky side down, for later use. Then, I firmly press the remaining frisket edges to make sure that no paint can blow under the edge.

I sprayed opaque white to fill in the moon. Less paint is better than too much. If you spray heavily, you will have puddles and it will take a long time to dry. If you paint too little, you can always add more paint in successive coats of paint.

Aim the airbrush so that it sprays over the edge of the tape or frisket as shown in Figure 6 – not into the edge of the frisket. This helps prevent the airbrush from blowing paint under the edge of the mask. Then, let the paint dry. You can use a hairdryer to speed up the process.

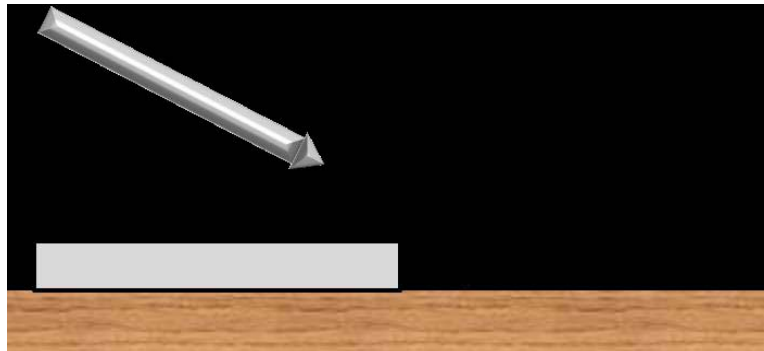

Figure 6: Airbrush over the edge of the mask

Once the paint was dry, I CAREFULLY replaced the moon sections back on the plate exactly where they were previously. Any deviations will show up as overspray, shadowing or unpainted edges. If you choose to draw in the lines after painting with a fine Sharpie marker, for example, these deviations can be subtly hidden.

Next, I lifted the frisket from black zone. It was less important to retain this frisket piece because I did not intend to reuse it. It is still a good idea to set it aside for reuse, just in case it is needed. As you lift the frisket, if you find corners of sections where the knife did not through, re-cut the frisket with the knife before lifting it. If you try to pull it apart, you will get little nibs where the frisket stretched and tore. I then firmly pressed all of the exposed edges. Keep in mind that the white paint on the sky frisket might still be wet or tacky. You can dry this with a hair dryer too.

I then painted the black sections with transparent black. I kept the airbrush well back from the plate so the color was even. If you are too close, you will get hot spots and puddles.

Next, I lifted all of the sky sections so that the only frisket remaining was the moon. I pressed the moon edges to seal them down, and then used three colors for the moon's aura: transparent gray, transparent blue and transparent purple. Each color radiated away from the moon in successive rings. I did not mask between the colors. Instead, I overlapped them for a blended effect.

Once the sky colors were dry, I lifted the moon and the rim tape. Finally, I sealed the plate with two coats of satin lacquer.

Summary

An airbrush can add a significant component to your arsenal of woodworking tools. You can create so many different effects with a brush from broad colors to fine detail. It allows you to precisely control the amount of color you are applying to a specific location, but it also allows you to seamlessly blend colors for very nice color gradients.



TURNING 26 WITH GEORGE FREEMAN



Wood Choices for Woodturning Projects



Discussion Topics

- Native Hard Woods
- Other Woods
- Regional differences in woods due to climate of that area
- Hardness and workability of various woods
- Intarsia / Marquetry use of colored woods
- Good woods for segmenting
- Spalting Wood
- Burls





Native Hard Woods: Number of species in Texas

Hickory – 10

Pecan – 3

Walnut – 5

Mesquite – 2

- Shagbark Hickory – *Carya ovata*
- Pecan – *Carya illinoensis*
- Black Walnut – *Juglans nigra*
- Honey Mesquite – *Prosopis juliflora*





Shagbark Hickory

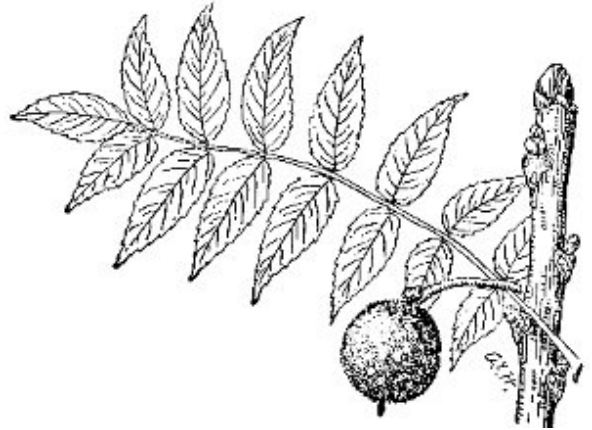

Black Walnut

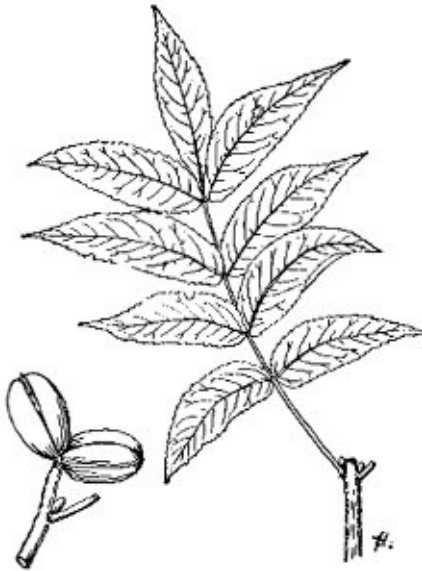

Pecan



Honey Mesquite



Hickory Bowl

Native Hard Woods

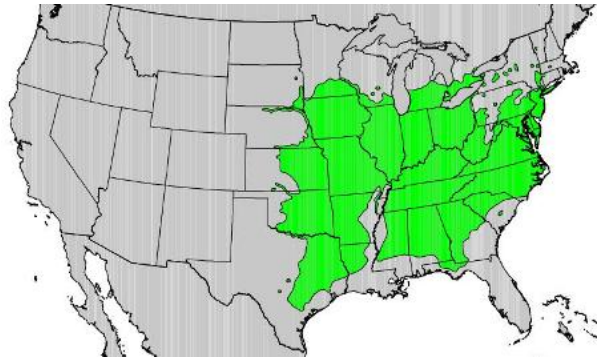

Black Walnut - *Juglans nigra*: The wood has a whitish sapwood and the heartwood is a chocolate or purple-brown, which is unique among commercial hardwoods of the United States. The wood is heavy, hard, strong and shock resistant. It is free from warping and checking. It has distinct growth rings, a mild characteristic odor, and is rated one of the finest domestic cabinet woods. Walnut is prized for veneer and furniture construction. It has a good texture and can be polished to a high finish. Walnut has a high tannin content. Walnut has crotches, burls, fiddle back, and stripes and makes a unique and beautiful bowl.

Its durability make it highly prized for turning, carving, furniture and cabinet work. European and some American walnut is prized for gunstocks.



Related Species:

Claro Walnut (*Juglans hindsii*)

Butternut (*Juglans cinerea*)

English Walnut (*Juglans regia*)

Peruvian Walnut (*Juglans* spp.)

Bastogne Walnut (*Juglans* x *paradox*)



Honey Mesquite - *Prosopis grandulosa* : The wood is heavy, hard, and strong with a dark reddish-brown heartwood and a very distinctive yellowish sapwood. Has a distinctive pleasant odor when turned. Mesquite burls are prized for their unique grain when turned. The wood is often crooked with pitch pockets and bark inclusions.

It is much used for smoking meats and because it is durable in the ground for fence posts. Wagon wheels, hubs and spokes were also made from mesquite. Recently it has come into its own for such things as attractive flooring, gunstocks, tables and furniture as well as turned objects. The seedpods were fermented into an alcoholic beverage by Indians.

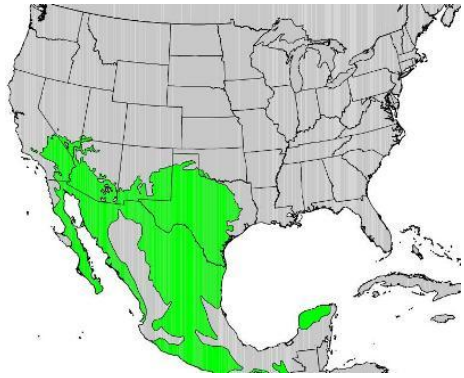

Screw Bean Mesquite - *Prosopis Pubescens*: A smaller Mesquite that grows in the Big Bend region of far west Texas.



The following other woods will be presented in this demonstration.

Live Oak
Red Oak
Water Oak
Post Oak
White Oak
Blackjack Oak

Loblolly Pine
Longleaf Pine
Slash Pine
Pecan
Hickory
Walnut

The Colored Woods

Red Cedar
Black Walnut
Bois-d'-Arc
Mulberry

Silver Maple
Red Maple
Hard Sugar Maple
Box Elder
Cedar Elm

Mesquite
Texas Ebony
Persimmon
Sycamore
Sweetgum
Hackberry

Fine Grain Woods

Catalpa
Bradford Pear
Black Cherry
American Holly
Crape Myrtle

American Elm
Honey Locust
American Beech
Magnolia
Bald Cypress

Ash
Eastern Cottonwood
Yellow Poplar
Yaupon Holly

Shining Sumac
Western Soapberry
Eastern Redbud
Black Willow



TURNING 26

WITH ROBERT HENRICKSON

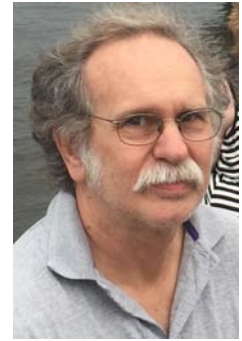

Snowflakes & Beyond - Doing More with Spindles

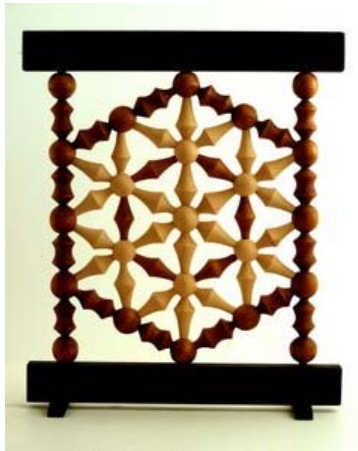
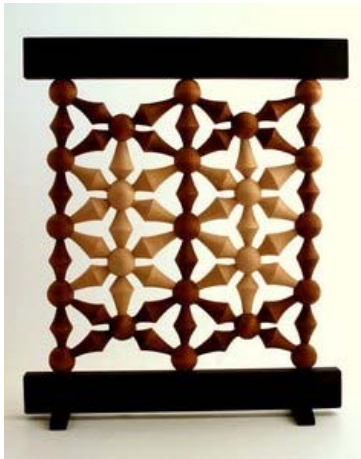
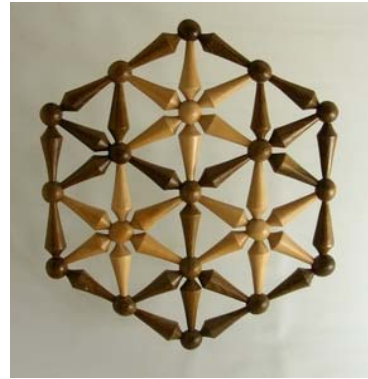
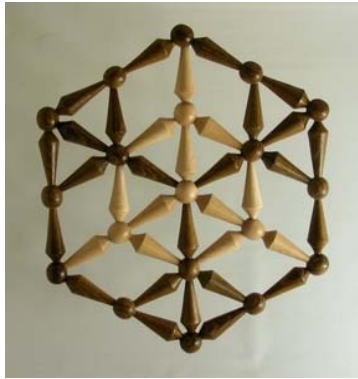
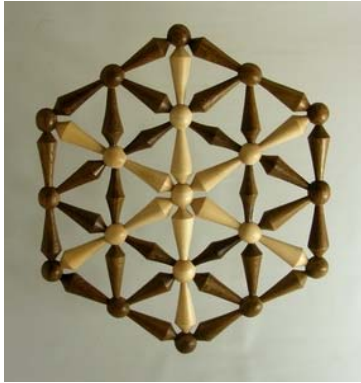

2107 SWAT

In the past spindle work played a much more complex and elaborate role in turning. In some cultures, spindles were ubiquitous. For example, in 15th-19th century Cairo, spindles were used in huge numbers to construct window screens, furniture, doors, room dividers, cabinets, balustrades, and much else; a single window lattice could cover several hundred square feet and incorporate tens of thousands of pieces. Today, multiple spindles tend to appear only utilitarian roles, such as staircases or chair frames and the like. Spindle turning now tends to focus more on individual pieces.

I will concentrate here on two-dimensional flat panels or lattices; this simplifies the drilling of holes since only opposed faces are involved; three-dimensional structures involve compound angles. Although both rectilinear and triangular/hexagonal grids may be used, I will concentrate on the hexagonal since that provides an good introduction to the various problems. Such grids have several advantages – only a single angle is involved (60°), interlocking is more secure, the structure is thus more rigid, and adequate space is left between holes so central nodes are stronger.

While each segment of a design could be a separate piece – think Tinkertoys – it is much better structurally to combine elements into longer individual spindles. Interlocking, so that one piece captures others, and opposed forces, from spindles joining at 60°, mean that a well-planned panel can hold itself together without glue. The panel is a web.

Work from centuries past can provide inspiration, as can geometry, tilework, and nature. The original inspiration for my hexagonal panels were snowflakes. Varying profiles within the panel can create embedded or interwoven motifs, which can be highlighted by using different colors of wood. Combination of colors with profile arrangements can also yield dynamic designs or three-dimensional effects.

TOOLS

- Spindle roughing gouge
- Spindle gouge, detail gouge, skew, bedan – personal preference
- 3/8" bedan or parting tool
- BRAD-POINT drill bits (usually 5/16", sometimes 1/4")
- School kid pencil sharpener (the cheap plastic things)
- Open end crescent wrenches (1", 5/16", perhaps 7/8", 3/4", 1/4")
- Story sticks based on each design
- Rubber bands, string (and perhaps bar or parallel clamps)

MATERIAL (typically 1" x 1")

Maple, cherry, beech, walnut, oak (preferably white), or any straight-grained, relatively fine-grained hardwood.

PRECISION / MEASUREMENT

Only a limited number of dimensions require close measurement. The only really critical one is the distance between the bases of the tenons at the end(s) of the piece; if this is off significantly, assembly will be flawed or impossible. Second to that is tenon diameter. An oversize tenon cannot fit the holes for assembly; slightly undersize will aid assembly.

In order to create a coherent pattern, the positions of important features along the profile and the distances between them must be uniform. A story stick can provide the locations. Diameters at any point along the profile are not critical – slight variation is not a problem. Your eye is entirely adequate to judge. If it looks right, it is! Remember – there is a lot going on in these panels – some variability in the details will not be noticed. ALIGNMENT is more important than diameter – it is much more easily seen. The ‘trees’ will get lost in the ‘forest’ – the individual details meld for the overall impact.

TURNING

For projects of this type, especially longer spindles, I prefer to hold one end in a chuck for better grip and greater stability. This applies especially to longer spindles (up to 1x1x18); the repeated alternation between relatively large and small diameters is easier to turn if one end is held solidly. I have yet to need a spindle steady, even with the longer pieces; cradling the spindle with your second hand is sufficient.

LEAVE A SHORT LENGTH OF STOCK SQUARE AT EACH END OF THE SPINDLE – THIS AIDS ALIGNMENT OF HOLES DURING DRILLING.

Rough the stock to round (the 1" wrench provides a strong and simple measuring tool) and mark landmarks from the story stick. After this, no further measurements are crucial – simply turn shapes and sizes by eye. One or two prototypes / trial pieces may help train your eye and provide a visual guide. On longer pieces, begin shaping at the MIDDLE, work toward the TAILSTOCK, then finally back toward the HEADSTOCK. This will result in less trouble with whipping and chatter. Nodes – points where spindles intersect – should be spherical. This aids both drilling holes and fitting multiple spindles.

When using 1x1 stock, a 3/8" bedan / parting tool provides an appropriate length tenon in a single cut. Use an open-end wrench to measure the diameter. Do NOT leave a distinct or pronounced shoulder at the transition from tenon to spindle profile; this will ease assembly and improve appearance. Several shorter pieces can be turned from a single piece of stock and cut apart.

Before removing the spindle from the lathe, mark the 'equator' of the nodes with a pencil line. This will help with positioning for drilling.



DRILLING

Use a BRAD-POINT bit, since almost all holes are likely to be drilled at angle and/or into a curved surface. Rigid concern with precise holes will make assembly difficult or even impossible – a small amount of ‘slop’ is essential for assembly. A slightly oversize hole will not be a problem once assembly is complete.

The square ends automatically align holes along the spindle, and assure that holes on opposite faces are truly 180° apart in two-dimensional work. DO NOT drill holes through – drill inward from each face.

Holes can be drilled several ways. Traditional artisans may do it entirely handheld. On the lathe, a platform sitting on the lathe bed, with its surface at a height so that the drill bit meets the middle of the spindle, allows the spindle to be pushed onto the bit. A drill press offers various options. Tilt the platform to the appropriate angle and drill the holes; a larger platform could be added for better support. I have found that using one hand to hold the spindle (remember the square ends!) and the other to control the drill works well, and is simple. A jig could be designed to hold the spindle for drilling, but is not necessary.

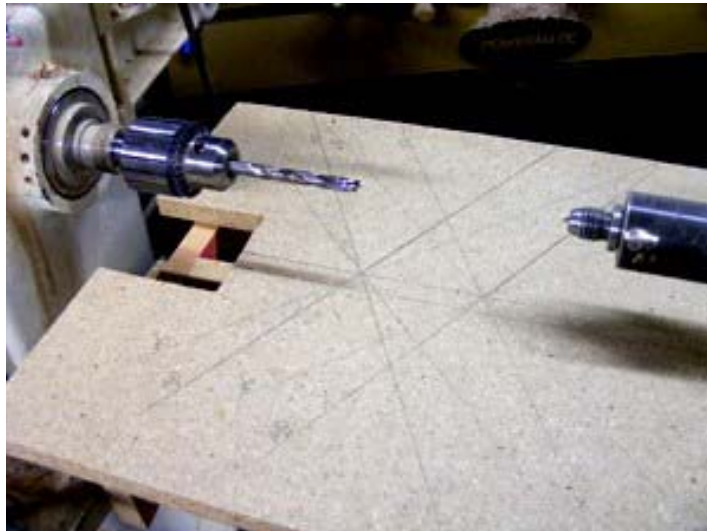

ASSEMBLY

Remove the square ends from the spindles, and finish the node ends. Remove any pencil marks, etc. Taper the tenons along part of their length with a pencil sharpener (the school kid plastic type is ideal). This eases assembly. Do not create a sharp point – it may scar the surface during assembly.

Assemble sector by sector – the smaller pieces framed by larger. Use rubber bands to hold things together, especially in the early stages. As assembly proceeds, the structure will become more rigid. Some creaking and groaning may occur (both you and the wood). Once the basic assembly is complete, small adjustments (push her, twist there) may be needed to gradually improve the fit. Especially with triangular/hexagonal lattices, this may take some time. Sometimes bar clamps may be used to help push the assembly together.



TURNING 26 WITH AL HOCKENBERY



Natural Edge Bowl from a Crotch



Natural edge crotch bowls are fun to turn and offer design opportunities, including heart shapes, while displaying pretty grain patterns.

Rough or stitched bark often indicates a bark inclusion which makes the blank unsafe to turn.



Cutting the blank begins by ripping the crotch with the chainsaw through the three piths. Ripping parallel to the pith about an inch or so will provide waste wood for the chuck or faceplate and yield one blank with great grain instead of two with average grain.

Blank Layout

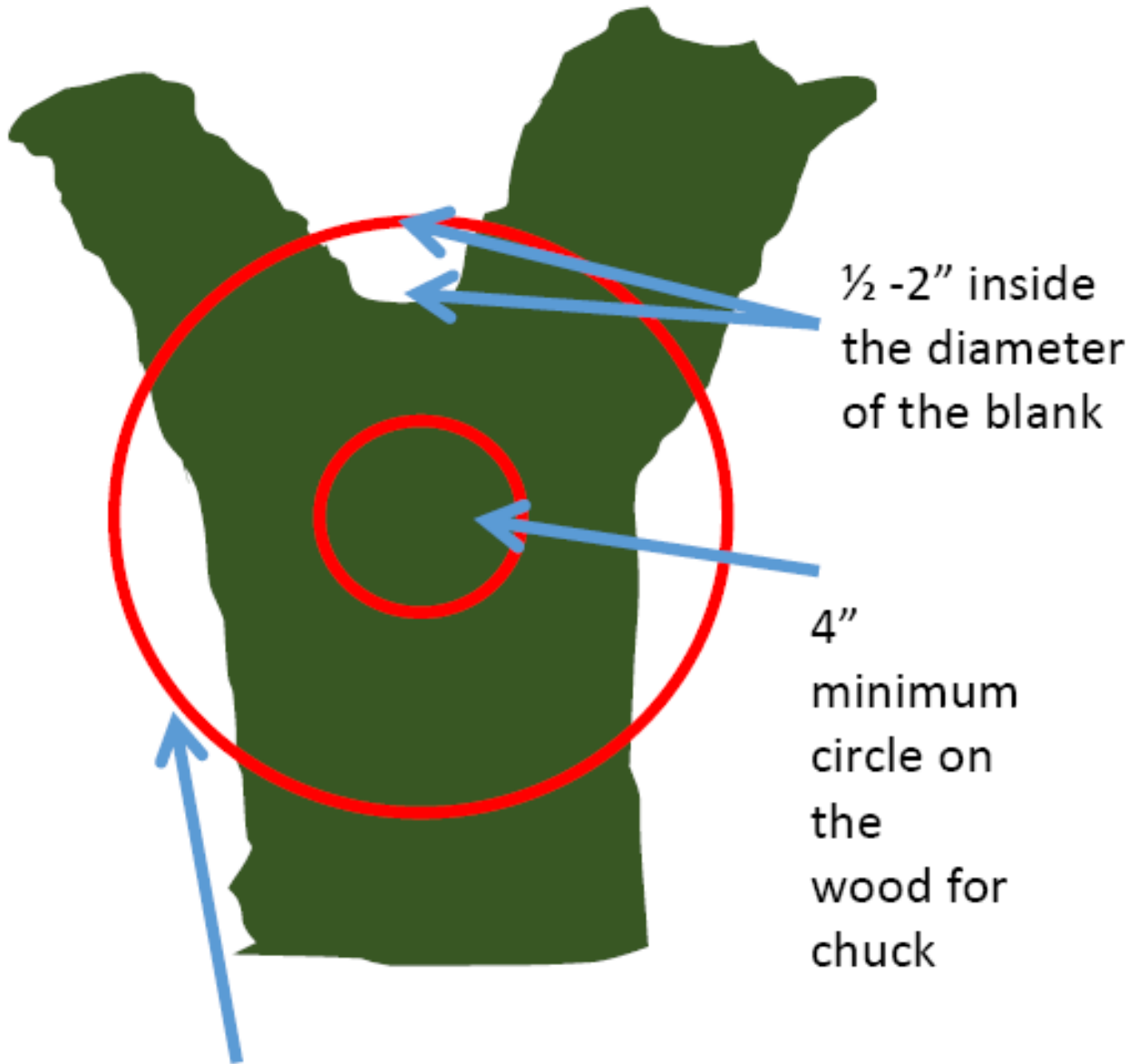

½ -2" inside
the diameter
of the blank

4"
minimum
circle on
the
wood for
chuck

11-10" diameter blank a good
size for the first one

Checking Rim Alignment

Thumb on the tool rest to mark where the edge of the wood meets the bark on one of the Y ends of the crotch.



Keeping the thumb in place rotate the blank to another end of the Y for a comparison measure.



In this example, the second Y has to move to the right. Usually 1/2 the distance work since the other part of the Y will be moving the other way.



Align the rim high points that are closest together

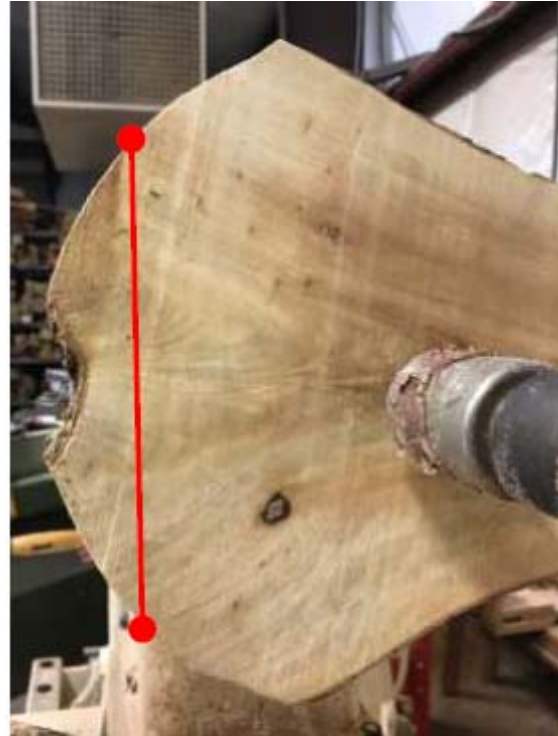

After checking the alignment, position the two closest together high points so they are in vertical alignment when viewed from the tailstock.



Keeping the two points in vertical alignment when viewed from the tailstock, loosen the tailstock and rotate the blank to align the two points so they are in true vertical alignment.

Align the third rim with the first two



Position the two aligned ends at the top so that they are aligned horizontally.

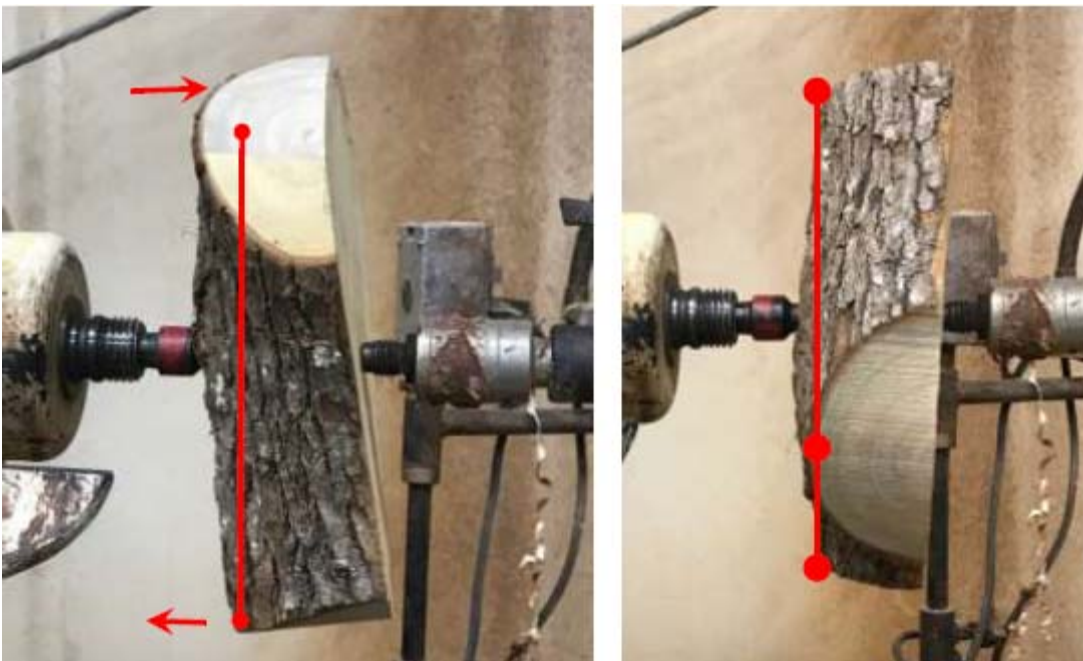

Loosen the tailstock and move the top to align the third end with the first two. Move the first two together keeping them horizontal and not twisting the blank left or right.

Additional information at: <http://swat.hockenbery.net/>



TURNING 26 WITH AL HOCKENBERY



Sand Carving - Design & Create Images



Sand carving is done by blasting a surface with images cut from resist material on it and removing the resist to show images defined by the textured background created by the blast media.

The process of sand carving has lots of small steps...

Cutting images in the resist

- Make or find image
- Convert to B&W in photo editor
- Refine lines and size in photo editor
- Copy the image to the resist
- Cut the images and weed the waste

Turned form

- Choose wood – consider the blasted area look
- Turn form
- Plan layout and numbers of images
- Create the surface you want in the resist covered areas
- Apply finish, paint, stain, dye etc.
- Make any alignment marks with watercolor pencil you know will come off with water
- Apply the resist images
- Squeegee the images in place
- Do the sandblasting
- Apply any finish/color to the blasted area using the resist to mask the unblasted areas
- Remove the resist
- Remove any adhesive
- Finish form

Sand carving the form

You can get started and do all the sand carving with the essential equipment and supplies listed below. If you decide to do a lot of sand carving the “nice to have” become essential.

Getting started equipment

- Compressor – 27 gallon
- Sandblast cabinet – HF
- Dust mask – n100 or p100
- Eye and hearing protection

Essential supplies

- Blast media – coarse ground glass
- Sandblast resist – Anchor BlastLite™ Stencil #T226, 22 mil
- Exacto knife

Nice to have equipment

- Vinyl cutter – titan 15”
- Computer with photo editor
- Compressor 60 gallon or larger
- Airbrush
- Pressure pot – ALC

Nice to have supplies

- Transfer tape – ORATAPE HT55 High Tack
- Air brush paints
- Spirit stains
- Leather dye

A small medallion is created in steps illustrated below:

Turn and sand the object. Finish the surface.

Draw and cut the image in the resist. Don't cut the backing.

Weed the waste from the resist.

Apply the resist and sandblast.

Remove the resist and apply the finish of your choice.



Blast Media

There are many choices of blast media. Ground glass and glass beads are good choices for woodturners. Coarse ground glass (25-40 grit) has a good aggressiveness for most woods. Glass beads (with less aggressiveness) are available in extra coarse (50-70 grit), coarse (60-120 grit), medium (70-140 grit), fine (100-170 grit), and extra fine (170-325 grit). Glass is not known to pose a health hazard and does not contain the free silica or carcinogens found in other blast media. The glass media can be reused as many as a dozen times and it does not tend to imbed itself in wood.

Additional reference: American Woodturner, December 2016, pp32-36, *Blast Carving* by Al Hockenbery

Sources

USCutter.com

- Sandblast resist – Anchor BlastLite™ Stencil #T226, 22 mil (15”x30 ft roll about \$60)
- Transfer tape – ORATAPE HT55 High Tack
- Vinyl Cutter

Grainger.com I order online and pick up at the store (check your local sandblast supply stores)
BALLONTINI Blast Media, Groud Glass (50lbs about \$55)

Harbor Freight

- Blast cabinet (\$90 on sale with a 20% off coupon from the Sunday paper)

Additional information at: <http://swat.hockenbery.net/>



TURNING 26

WITH AL HOCKENBERY



Turning Triangles - Unique Multi-Center Turning



Three sides from 3 centers

Five sides from 5 centers

Two sides from 2 centers

- Lamps
- Weed Pots
- Pedestals
- Napkin Rings
- Tool Handles
- Bowls
- Legs
- Boxes
- Pepper Mills
- Ornaments



Napkin Rings

Matching set

- Common theme
- Individual identifier
- Historically napkins ere not laundered between meals



Hole 1.5 inches

The layout goal is to have three centers marked on each end directly opposite the centers on the other end.

A reference line (corner line) lines up the centers on each end.



Three Center Layout

- Turn a 2.5" diameter cylinder
- Pick the grain orientation you want. I pick a face I like. then draw a line opposite for one corner.

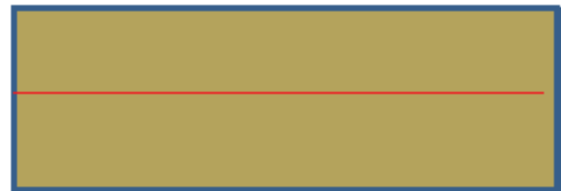

- Use index wheel or trifold paper to make the other two corner lines.
- Using a compass, mark a circle 2" diameter on each end.

Napkin Ring Layout

- Use a straight edge from each corner line to the center of the cylinder to mark the three center points on each end.

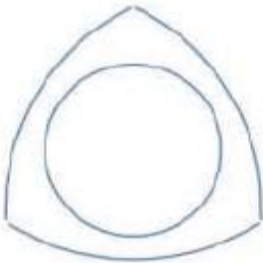
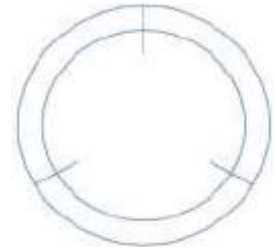

- Using the cylinder center, part in to less than 1.5" to define the napkin rings.
- Using the 3 centers, turn each face to the corner line. Be sure the faces meet at a sharp corner.
- Drill 1.5" hole.

Two Sided

- Turn cylinder 2.5"
- Mark two centers 1/2" to 3/4" from the original center

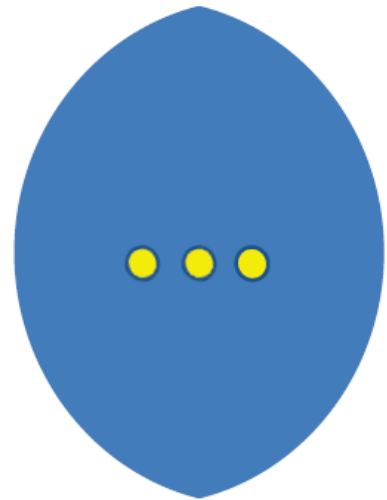

Additional information at: <http://swat.hockenbery.net/>



TURNING 26 WITH ALAN LACER



My Friend the Skew

Skew Chisels

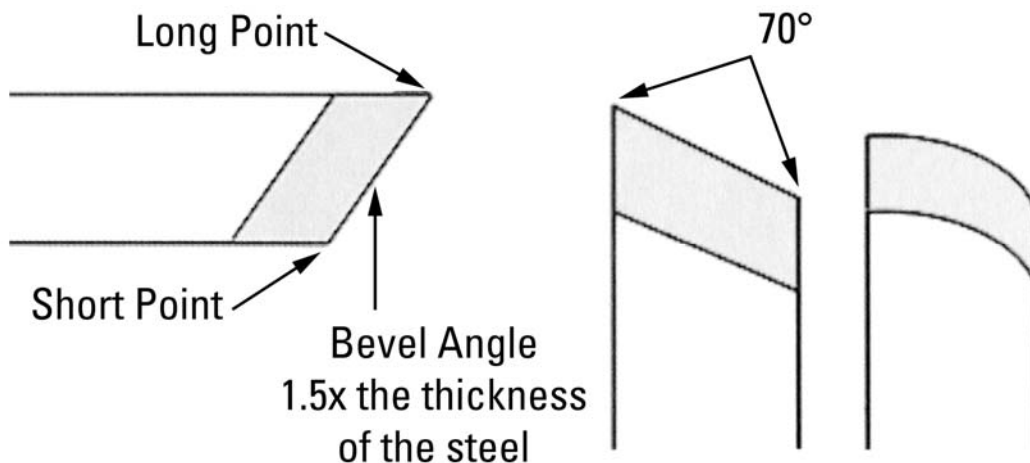

SKREW CHISEL SELECTION: I prefer rectangular sectioned skews, the heavier the better (at least 1/4" thick, better yet, 5/16" or 3/8") with the short point side corners rounded back to the ferrule, the long point side corners chamfered (slight rounding) back to the ferrule. I do not like the oval sectioned skews: they are overly thinned out, rock on the tool rest when grinding, nearly impossible to do the peeling cut (which I use a great deal), and presents a changing angle to the wood as presented in several of the cuts below – such as the rolling cut.

Sizes: I primarily work with two sizes: a smaller one that is 1/2" or 5/8" and a larger one that is 1 1/4" or 1 3/8". These sizes work well on all the cuts below on stock 4" in diameter down to miniature sizes.

Preparation: get it sharp through grinding, refine the edge through hand honing (I prefer a diamond hone) and as an option, power hone using power honing on a MDF wheel charged with buffing compound that cuts high speed steel. Make sure the tool rest is filed flat and clean, wax the top surface of the rest. Drive the work with a cup/ring center rather than a spur – especially if you are in a learning phase.

CUTS:

PLANING: most commonly done with the short point down and leading the cut – but cutting anywhere along the area just above the short point to just above center of tool, handle is positioned at about 45 degrees to the axis of lathe. Problems: skating, dig-in, ribbing, chip-out.

ROUGHING: using the tool in the same position as the planing cut, the skew can be used to round smaller diameters (usually under 2 1/2") and shorter pieces (generally under 18" in length). Is very much a pushing off of the corners to reach the cylinder. In chippy woods like red oak or ash, I either use the planing approach but shorten the length of each cut or use a peeling approach – followed by a planing cut to clean the surface.

PEELING: using the skew like a veneer peeler's action on a log. The cutting edge is held parallel to the lathe's axis, but with the handle low in back to provide a cutting edge that has bevel support – not a scraping action with just a sharp edge. Place the long point against the side of the wood you intend to keep. I normally use only a portion of the tool's edge as too heavy of a cut is hard to make or control. This is a sizing and rough cut – not for finishing. It can be used to take the corners off of a square, cut tenons, or remove large amounts of waste material.

VEE: long point down, cutting with an arcing motion. For the first cut, the point is at a right angle to the axis of the lathe. To deepen or widen the "V" that is created, come from the side of the original cut, being sure to clear the long cutting edge away from the area just cut. Problems: skating, burning, "stalling out."

SHOULDER or FACING-OFF: long point is down, long cutting edge is tilted away from the face of the shoulder only a few degrees (2 to 5). Cut is performed high on the work, using an arcing motion and ending above the center axis of the lathe. Problems: skating on entry or at any time on the face of the shoulder, dig-in, "stalling out," torn grain.

SAUCER: done very much like the shoulder cut, except the action is now concave. Since this is cutting somewhat against the grain, don't take the cut too deeply into the end-grain. Useful in doing the bottom of projects like a goblet, vase, toothpick holder, lidded box, etc. or for cutting rings free on a shaft.

PARTING: done with the long point down, a series of vee cuts to part a small work pieces / projects off at the headstock side. Tends to avoid many of the problems of parting tools: cleaner cut on the end-grain and seldom snaps the piece off near the conclusion to create a small hole in the end of the project.

PUMMEL: the process of turning square elements that transition into round. I prefer to cut these with the long point down – especially square shouldered pummels. Layout the placement with a single 90-degree line (using a square or protractor). Cut to the waste side with a Vee cut – then turn away material on the waste side until you reach a cylinder (using either a peeling or planning cut). Make the cut to the line using the same method as for a shoulder cut (for the square shouldered pommel). For a curved pommel, make two 90-degree lines – one for the ending point (meets the rounded area of your project) and one for the starting point of the pommel. I usually go ahead and create a square pommel at the end point. Then in a series of light cuts, add a curving motion to create the curved surface until you reach the line that marks the starting point of the pommel. If a relatively friendly wood, I lead with the long point through the entirety of the cut. If a difficult wood (usually very soft or easily torn on the end grain), I start with the long point in the wood, then raise the handle with my back hand to allow cutting in the area just above the long point.

ROLLING: using the skew to produce a convex shape, such as a bead. For small beads (under 3/8" wide or less) I often use the long point. For most beads and other convex shapes of a larger size I make the cut with the short point down. You may cut with the short point in the wood (to assist with keeping the tool against the side of the bead and with a bevel rubbing) or with the area above the short point but not above the center of the tool's long cutting edge. Problems: skating (creating slashes in the bead), dig ins (getting the trailing edge/point pulled into the wood), shapes that are not rounded – but were intended to be convex.

COVING: using the skew to produce a concave shape. Usually done with the short point down, moving the tool with a scooping action. Here the curved edged skew certainly performs better. Problems: skating and failure to produce a curved surface in the cove.

ROUGH-GRAIN: using the skew as the final tool to work an area of twisted grain, severe chip-out or even a knot. First the area is lightly cut with a roughing gouge, cutting edge at a 90 angle to the lathe's axis, with bevel support. Make the cuts across the difficult area lighter and lighter

until almost dust like in their action. Next, be sure the tool rest is almost touching the wood, cutting edge of the skew is held parallel to the lathe's axis, tool handle is horizontal, edge is presented in a scraping approach with no bevel support. Make very light passes across the difficult area, completing with only the lightest of cuts.

END-GRAIN SCRAPE: using the skew for scraping directly across end – grain as found on the rims or bases of such projects as lidded boxes, goblets, toothpick holders, etc. Get the tool extremely sharp by honing, place the tool rest as close to the work as possible, present the tool facing the end-grain area, the tool handle should be horizontal (to present the edge in a scraping approach with no bevel support) and lightly scrape across the area. You should be getting tiny ribbons rising from the edge – if not, you may be tearing the grain.

SHARPENING OF THE LACER SKEWS

First, let me describe the shape of the cutting edge. About one-fourth to one-third of the edge from the long point is a straight line – and 90 degrees to the long point edge. The balance of the edge is a curved shaped. Two other aspects of the edge are critical: try to maintain an angle of approximately 70 degrees from point to point, and grind the bevel length to approximately one-and-one half times the thickness of the steel.

Once these shapes and dimensions have been achieved, actual sharpening of the edge is next. Set the tool rest of a dry wheel grinder to the preferred bevel angle (achieved by grinding the length of the bevel to the one-and one half times formula). Start with the straight part of the edge held horizontally (or parallel to the axis of the grinder) and grind that region. Next, with a pivoting/fan motion, grind the curved section when it is moved into a horizontal position on the wheel. I try to maintain the same position on the tool rest and simply pivot or rotate the tool from a single point. Grind until sparks just appear over the top edge of the tool. Turn the tool over and grind the other side in the same fashion. The objective is to grind a slight hollow-ground edge with a single facet.

Work slowly and keep the skew **flat on the tool rest** of the grinder. Next, I hone four faces of the skew. This is best done with a diamond honing stone in a “fine grit” of 500 or 600. Since there is now a hollow-ground edge, simply touch the stone at the back of the bevel, close the angle towards the cutting edge until you have a **two-point contact**: (1) at the back of the bevel and (2) just below the cutting edge. Work the honing stone along both of the long cutting edges in this manner – lengthwise with a “back and forth” motion.

Then place the stone on the long flat edge behind the long point of the skew.

Hone this area with the same back and forth motion, being sure to keep the stone flat on this surface. Finally, hone the area behind the short point in a similar fashion – even though that section has been rounded all the way to the ferrule, you can still refine the short point by keeping the hone flat on the edge behind the short point. Honing is excellent following grinding to refine the edges, but also is used to keep the edges sharp while working. **Rule:** hone frequently and thereby avoid excessive trips to the grinder.

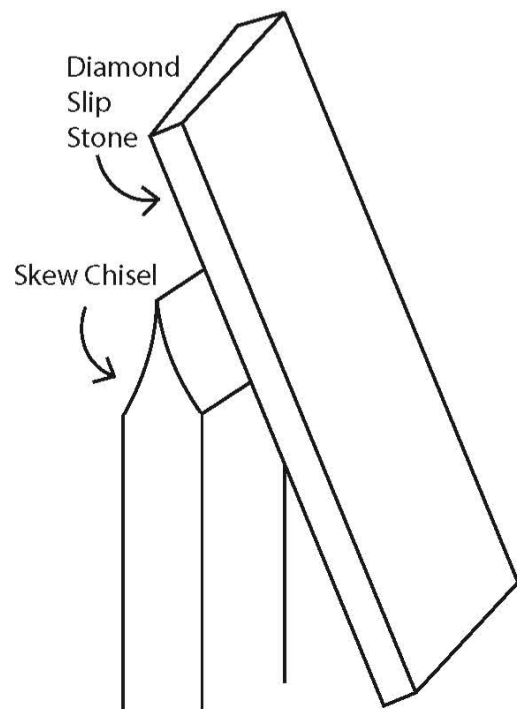

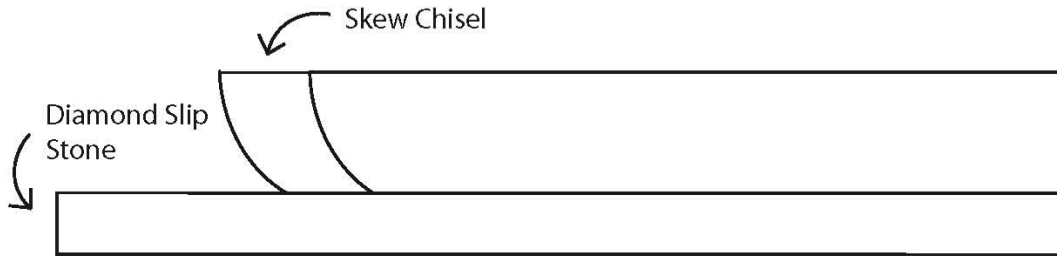

Thoughts on this grind: I have tried a variety of grinds for the skew and prefer this style. I have found this grind – or similar grinds – being used by woodturners in North America over much of the last century. The advantages of it as I see it are several: the straight section is excellent for peeling cuts (much like a large parting tool), slicing rounded pommels with the long point down and as my scraping area; the straight section also serves as a warning to stay clear of when doing planing and rolling cuts (such as beads) with the short point leading the cut **AND** provides additional clearance of the trailing point in these cuts; the curved section works well for planing cuts in “chippy” woods; the curved edge wraps over a curve better than a straight section (as in convex shapes); the curved area can be used to scoop concave shapes; creates 15 to 20% more cutting edge than a traditional grind of the same width of steel; when a dig-in occurs it is far less violent than the traditional grind.

LACER'S SKEW WARM-UPS

(Go to www.alanlacer.com for more information)

Suggested wood type and dimensions: something soft and dry such as alder, poplar or pine, approximately 1 3/4" square and 5" to 6" in length.

BLOCK #1:

- Remove corners from 1/2 the length of the first square block using a planing method, the other half by peeling.
- Turn the block to an even cylinder using a planing cut.
- From the middle, taper the block down to a straight taper just slightly larger than the drive center; do the same to the other half.
- Turn the block back into a small cylinder.
- Avoid hitting the drive centers (leave larger diameters at the ends); turn as small a cylinder as possible.

BLOCK #2:

- Turn a cylinder from the block.
- For 1/3rd of the length create V's that are below the diameter of the cylinder.
- For another 1/3rd of the length create V's that are proud of the surface.
- For the remaining portion of the cylinder create several individual micro beads, then a grouping of three or four micro beads.
- Face off both ends of the cylinder with shoulder cuts.

BLOCK #3:

- Create a square-shouldered pommel on one end of the square, a rounded shouldered pommel on the other end.
- Peel into the middle to create space for two more pommels. Do a rounded pommel on the left side, a lamb's tongue/ogee shouldered pommel on the other.

BLOCK #4

- Turn the block into a cylinder.
- Starting at the left, lay out (using V-cuts) three beads approximately 1" wide, then three 7/8" wide, then three 3/4" wide, then three 1/2" wide.

BLOCK #5

- Turn the block to a cylinder.
- In the middle turn a 3/8" wide bead that is proud of the cylinder. Using saucer cuts, cut the bead free of the cylinder.
- Using a coving cut, trap the bead within a deep cove.
- On the side near the headstock, about 1/2 " from the end, make a series of V cuts.
- Round over the end of the remaining stock that is close to the V cut.
- With a series of V cuts, part off the stock leaving a nice rounded end.

BLOCK #6

- Find a blank with one or more large, solid knots.
- Plane the square into a rounded shape being careful around the knots.
- Try to cut the knots as cleanly as possible by using a planing method.
- Vary the angle of presentation and a very slow feed rate.
- Complete by light scraping across the knot.



TURNING 26

WITH JANICE LEVI



Bangle, Pendant, and Earrings



This is a beautiful set to make and it is an excellent gift—if you can get the wrist size of the lady. Because you'll be making a bracelet, select a good hardwood. Maple, mesquite, and pecan are a few local woods that make beautiful sets. The exotics are also good choices and because this set takes such a small amount of wood, you can splurge. Purple heart, blood wood, ebony, mahogany, yellow heart and others are good choices.

Your blank will need to be about 3 ½" X 3 ½" X 1" thick. To determine the size of the interior opening, ask the lady to wad up her hand as if she were going to put on a bangle bracelet. Then use a soft tape measure (like a seamstress' tape) to measure the circumference of her hand at the widest point. Now for a little math. Divide that circumference by 3.14 (pi) and you will get the diameter of the interior opening. The opening will generally lie between 2 3/8" for a small hand to 2 ¾" for a larger hand.

To make turning easier, remove the corners of the blank on a bandsaw. If the flat surfaces of the blank are rough, sand one of the surfaces smooth and flat on a belt sander. Mark the center of the unsanded side with a pencil.

You will need a wasteblock to hold the blank. It should have a 3" diameter at the outside. True the outer edge. Use double-sided tape to hold the blank to the waste block. Before pressing the sanded side of the blank into the tape, bring up the tailstock and center the point on the pencil mark. Use a ruler to mark the interior diameter of the finished bracelet.

To avoid puncturing the wood with the center point, use a spacer to protect the wood's surface. Use a bowl gouge to true the outside edge. The finished thickness of the bracelet will be about 1/4" and the profile of the exterior is open for artistic interpretation. I like a simple slightly domed profile.

Because the blank is attached to the waste block on one side, you are limited to how much shaping you can do, but you can work on that more later. When the overall thickness is about 1/4" from the pencil line marking the interior diameter, it's time to part off the bracelet from the interior wood which will become the pendant and earrings. I use a parting tool with a low height profile. Be sure to line up the parting tool with the bed of your lathe and go straight in on your cut. Keep going until the bracelet is free of the center wood.

Set the bracelet aside for now. It's time to work on the earrings and pendant. You are left with a blank attached to the wasteblock that is about 2 1/4" wide and 1" thick. With a bowl gouge, true the outside surface then shape the face so that it is slightly convex. This will become your pendant, so you may choose to add some enhancements. First, sand the surface through all grits, then using a three-point tool or a skew, you can add little grooves that dress up the surface.

Use the tip of a skew to lightly cut the fibers about 1/8" from the edge. Then use a parting tool angled slightly to the left and begin parting off the pendant. Before the pendant is completely parted off, sand the outside edge to a smooth curve. Rather than part the pendant off, I like to use a fine-toothed saw to cut through the last 1/4" or so.

Even though the back side is rough, set it aside for now. The remaining wood on the lathe will become your earrings. The outside edge has already been trued so use your bowl gouge to turn the surface slightly convex, just as you did with the pendant. Sand the surface and add enhancements with a skew or three-point tool. Use a skew to lightly cut the fibers about 1/8" from the edge, just as with the pendant, then use the parting tool and angle it so that the back side will be slightly convex, just as with the pendant. Before parting it off completely, sand the edge to a rounded surface, then use the saw to cut it off the waste block. Both the pendant and the earring blank will be about 3/16" –1/4" thick at the thickest point.

To finish the back side of the pendant and the earrings, you have two choices. You can mount them on a small diameter waste block with double-sided tape and turn and sand the back side on the lathe. Or, you can mount a sanding disk holder in your drill press and sand through all the grits to finish the back side. When the earring disk has been completed, use a scroll saw to saw it in half. You can mark a straight line or a slightly curvy line. Sand the cut edge.

Now it's time to get back to the bracelet. Remove any wasteblocks and expand the jaws of your scroll chuck into the bracelet. Use a bowl gouge to gently round over the outside edge. If the inside is quite rough or has been cut on a light angle, you can use your spindle or detail gouge and lightly sheer scrape the inside down to the jaws. Sand the exterior, edges and as much of the inside as you can reach.

Turn the bracelet around and repeat the process for the other side. You may choose to add enhancements with a skew or three-point tool at this time. If there are some rough areas inside the bracelet, you may use a Dremel sanding bit to smooth the area or you can hand sand it. It's now time to apply the finish of your choice.

To assemble your pendant and earrings, add the jewelry findings of your choice. You now have a beautiful matching set to show off to your friends.

RESOURCES:

- Double-sided tape (SpecTape from Wood Craft is a good choice. Do not use carpet or mounting tape)
- Jewelry Findings—Michaels, Hobby Lobby, JoAnn, Rio Grande (online)
 - Chain or cord for necklace
 - Jump rings
 - Neck clasp
 - Crimps to attach cord to clasp
 - Ear wires



TURNING 26 WITH JANICE LEVI



The Fine Art of Finials

TOOLS:

- 3/8" spindle gouge
- Roughing gouge
- 1/2" skew
- Detail gouge
- Parting tool
- Thickness gauge/caliper



A treatise on turning finials

You have selected a beautiful piece of wood and turned a globe for your Christmas ornament. Next you select two different species of wood—one for the top finial and one for the bottom finial, or icicle. You want this to be a special ornament so you add all the feature items that you have learned to turn over the past several years—captured rings, beads, coves, “V” cuts. You finally put it all together and it’s not quite what you had envisioned. It’s not “terrible,” but it’s not “wonderful,” either. Of course, the ornament will be appreciated and loved because you made it, but let’s look at a few simple steps that might make the ornament even better.

First, what is the goal in turning the ornament? Usually, the obvious goal is to turn a keep-sake to give to a friend or loved one. But beyond that, the goal is to turn an ornament that will be pleasing to the eye. If you have selected a beautifully spalted or figured piece of wood for the globe then you want the finial to complement, rather than argue with, that globe. So keep the wood species for finials to one. Don’t overload the eye with too many types of wood all jumbled together.

If we go back to art class, you might recall that dark and light colors create different visual responses. Light colors, such as white or yellow, visually jump forward and call attention to themselves while dark colors, like black or dark brown, visually recede into the background. If

the wood for the globe is highly figured and you want that to be the focus of our attention then selecting a dark wood that visually recedes will be more complementary than a light color that visually calls attention to itself. Conversely, if the globe is rather plain, then perhaps a more figured or colorful finial would be in order.

If the globe wood has several colors represented in it, you are always safe to choose a finial that matches one of those colors. Keep in mind that the darker wood will visually recede while the lighter wood will visually forge ahead. I like to turn spalted wood and I almost always choose a dark wood like African ebony or blackwood as the finial. For one thing, there is black represented in the globe, and for another thing, I want the globe to be the focus of attention and the black finial will complement while visually receding.

So, you have chosen your globe wood and a complementary wood for the finials. What should you consider next? All too often, I see finials that overwhelm the globes in both size and feature items. Let's look at the size of the finial first. We turners often like to impress others with our turning skills and so we go about turning a two inch globe with a twelve inch icicle! Well, that may be impressive, but it is probably not very aesthetically pleasing. How does one go about achieving "aesthetically pleasing?" The ancient Greeks figured that out about 2500 years ago. We call it the "Golden Mean." Basically, it is a ratio applied to height and width and length. (I'm not the expert here and a whole lot of you mathematicians may be cringing, but I'll do the best I can.) The ratio of 1:1.618, when applied to a bowl, a hollow form, a lidded box, or a Christmas ornament, will result in an aesthetically pleasing appearance. So, if my globe is two inches in diameter then the bottom finial should be about three and one-fourth inches long. However, I prefer to stretch that ratio a bit and use the "rule of thirds." Applying that rule would allow for a two inch globe to have a four inch finial. Well, I am a woodturner; I like to be a bit flamboyant.

At any rate, our goal in turning our ornament and finials is to have an end product that looks good. The last thing that we need to consider, then, is the number and type of feature items that appear on the finials. To begin with, the lower finial, or icicle, is often turned way too thick. You are not turning a ball point pen here; you are turning an icicle. It should look delicate, like an icicle. Remember that the finials are to complement, not steal the show, in the completed ornament. I apply the Golden Mean or the "rule of thirds" to the icicle itself. If it is four inches long, I divide that into thirds and the lower two-thirds should be relatively free of beads, coves, and "V" cuts. If there are features at the end of the icicle, they should not be larger than one-third the total width of the largest feature that will appear in the top one-third of the icicle (I am not including the base of the icicle in this measurement).

The top finial needs to look like it is related to the bottom finial, or icicle. You have chosen the same type of wood, now choose similar cuts. If you use sharp angle cuts on the bottom finial, use some sharp angle cuts on the top finial. If you use beads on the bottom, use beads on the top. You get it!

Finally, you have made all the right decisions and the final result is a beautiful ornament that appears balanced and aesthetically pleasing. The woods you have selected complement each other. And, the finials are of a delicate size that is not too clunky nor overwhelming. Congratulations on an ornament well turned!

Procedure for turning the bottom finial, or icicle

- 1 To fit a 2" globe, begin with a blank that measures about 1" x 5 1/2". Insert the square stock into small jaws and use a roughing gouge or spindle gouge to turn the last 2" round. To avoid vibration, do not turn the entire blank round.
- 2 Use a 3/8" detail gouge or a skew to create the bottom point. The widest part of the bottom feature should not be larger than 1/8" to 3/16".
- 3 Since you have mentally divided the icicle into thirds, use a spindle gouge to work toward the first one-third mark. A general rule to follow is that there should not be any

straight lines in the icicle, so gently increase the diameter above the point from about 3/32" to about 1/8" at the one-third point.

- 4 Sand as you go, supporting the back of the icicle with your finger. Don't try to go back to an area that has been turned because you may break the icicle.
- 5 At the one-third point, you may choose to add a very small feature item such as an inverted "V" or a small bead. Use your skew to turn the "V" or your detail gouge to turn the bead. Or, you may choose to continue toward the two-thirds point without adding any additional feature items.
- 6 At the two-thirds point, begin adding turning features, but don't overdo it. The features should get larger and larger, ending with the base that will attach to the globe. You may choose sharp angles or beads, or a combination of both.
- 7 Use a thin parting tool to undercut the base. (This involves angling the tool away from the headstock to create some relief area under the base so it will fit onto the curved globe.)
- 8 Continue using the parting tool to form a tenon that is 1/2" in diameter by about 1/8" in length. (I always drill a 1/2" hole all the way through my globes in preparation for hollowing. This way, both top and bottom finials always require a 1/2" tenon.)
- 9 Before parting off the icicle, sand the last portion. You may choose to add a finish at this point. Often, all that is needed is a friction polish or wax.

Procedure for top finial

- 1 Using the same wood as the bottom icicle, select a design that will complement that finial but in a much shorter size. Mount the square stock into small jaws. This time, I begin with the tenon first. After rounding the blank, use a parting tool to undercut the base and form the tenon. (Note: Some turners like to start with the top of the finial so they can drill a tiny hole in the top to accept the screw eye used for hanging the ornament. This option works well.)
- 2 Use a skew or detail gouge to create feature items that are similar to those in the icicle. The top of the finial should be wide enough to be drilled for the tiny hole that will accept the screw eye used for hanging.
- 3 Sand the top finial and apply finish, if desired.
- 4 Carefully part off or saw off the top finial. Use an awl to mark where the hole will be drilled for the screw eye.
- 5 A large drill press will work to drill the tiny hole for the screw eye but if you have a Dremel drill press, that works even better. Insert the tiny screw eye with a bit of wood glue on the tip.
- 6 If the finials fit snugly into the globe, use wood glue and attach both at the same time. If the fit is a bit "sloppy," attach one at a time, allowing for each to dry overnight. I don't recommend using cyanoacrylate (CA) glue, especially if the fit is loose. I've ruined several ornaments by attaching an icicle off center due to a loose fit. (That's why I always use a 1/2" hole in the ornament and tenons on the finials now.)
- 7 Your beautiful ornament is now truly an heirloom.

RESOURCES:

1. Screw eyes—Woodworks, Ltd. At www.craftparts.com (\$2-4 per 100, 1/32 or 1/8" interior dimension; brass and silver)
2. Screw eyes—Divine Beads and Findings on Etsy 9X3mm, 150 for \$3.50



TURNING 26

WITH ERIC LOFSTROM



© Photo by Fred Abeles

Skew Skills - Making the Cuts

During this demonstration, I will share how to "make the cuts" using only a skew! Learning this foundational tool will make cutting with ALL tools easier. In addition to reviewing basic spindle turning techniques, I will emphasize simple sharpening methods used to create a razor's edge and key "dance moves" to help you finesse ultra-clean cuts with control! My demonstration will showcase a foundational progression of skew cuts and will end with my favorite skill-honing projects; eggs and my version of elegantly-embellished finger-tip spinning tops.



© Photo by Fred Abeles





TURNING 26

WITH ERIC LOFSTROM



Square Rimmed Bowls

During this demonstration, I will create a bowl with an outward flowing rim using a square-cornered blank. My techniques will showcase the fingernail bowl gouge, negative-rake scraper, and methods of mounting a facegrain blank to the lathe for turning. I will emphasize tool control and efficient biomechanics to create a graceful form. I will demonstrate how to get an ultra clean cut from the tools and will complete the piece with simple, yet elegant embellishments!

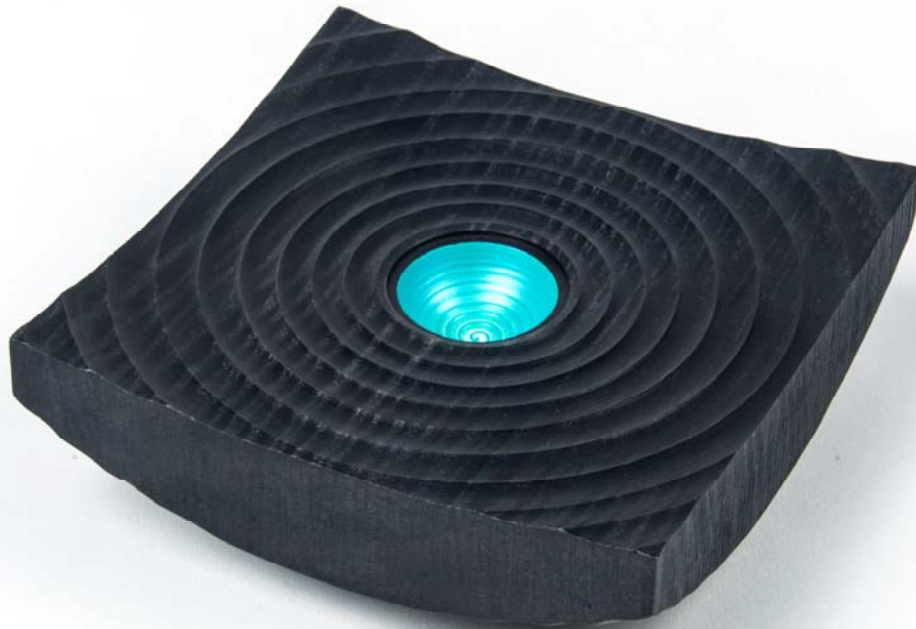

© Photo by Fred Abeles



TURNING 26 WITH DAVID MUELLER



Use of Ground Plastic Beads as Enhancements

Background

After unsuccessfully trying to use minerals for enhancements and filling voids, I started using ground pony beads as an alternative. Pony beads were chosen for several reasons. They are inexpensive and come in about 150 different colors. You can easily prepare them by grinding in a small coffee grinder or an inexpensive food processor. Best of all, they can be turned just like wood with any of your turning tools. Minerals, on the other hand, must be crushed with some difficulty, come in limited color choices, are expensive, and will destroy your tools if you try to turn them.

Examples

Over a couple of years of using them, it became clear that there are many different applications for ground pony beads. They can be used for the obvious application of filling voids and worm holes, much like Inlax and turquoise. Alternatively, they can produce images cut into the surface of a turning with a carbide burr (Figure 1). You can fill grooves turned in bowls (Figure 2), decorate pendants (Figure 3), cast pen blanks using Alumilite or epoxy (Figure 4), make rings (Figure 5) and decorate Christmas ornaments and boxes. Although the application details may vary slightly, the technique for each is basically the same.



Figure 1. Tree Image



Figure 2. Bowl with Filled Grooves



Figure 3. Decorated Pendant



Figure 4. Cast Pen



Figure 5. Rings

Equipment/Materials Needed

Pony beads - They come in two sizes, 6X9 and 4X7 (width X diameter in mm) and can be purchased on-line and at any craft store. They come in transparent colors, opaque colors and pearlescent colors (Figure 6). You can also use solid plastic beads, however, the pony beads with a large center hole seem to grind much easier and faster. Pony beads typically are sold on-line in packs of 100 beads (about 25 grams) for about \$1.25, or 500 beads for about \$2.65. They can also be purchased in craft stores like Michaels or Hobby Lobby at slightly higher prices and fewer color choices.

Grinder - Beads can be ground in a small coffee grinder or a larger food processor (a 2 cup size with a sharp curved blade). It is unnecessary to buy an expensive grinder. Grinding the beads is pretty hard on a grinder, so purchasing an inexpensive machine that can easily be replaced may be the best choice. Not all grinders or food processors will effectively grind beads, so when you find a good one buy a couple.

Sorting - After grinding the beads you should sort them into two or three groups based on size. I sort into three groups – coarse for larger areas for a crystalline look, medium for most applications and fine to fill in the space between the medium and coarse particles so there are no voids. When applying them, I try to keep the maximum particle size less than half of the smallest dimension I am filling. Sorting the bead particles can be done with cheap strainers of different sizes (Figure 7). Sorting is much easier using calibrated sieves (Figure 8) purchased on-line, although the sieve cost is about 4 – 5 times more expensive than a cheap strainer. Links to vendors are at the end of this document.



Figure 6. Pony Beads



Figure 7. Cheap Strainers



Figure 8. Calibrated Sieves

Glue - The bead particles are generally applied in a recess or turned groove using thin CA glue. You can also use clear epoxy, but the wait for it to cure slows down your progress, and can't be used effectively when the bead inlay is on the outer circumference of a bowl or spindle like Figure 2.

Turning/Finishing - No special tools are needed to turn or sand the bead inlay and most any finish is compatible. However, before using a new finish I would try it on a small test piece to make sure the finish sticks and cures.

Grinding and Straining the Beads

When you grind the beads try small amounts first (1/4th of a 500 bead bag) until you see how well your specific grinder works. The longer you grind, the more fine particles you produce. Pulse the grinder and do not run it for longer than 5 seconds per pulse. Be careful of grinding too long, as it will melt the beads. Even with short grinding periods, over time you will see a buildup of bead material around the inside of the grinder that you can remove by scraping. After grinding for a total of about 20 - 30 seconds, you will have a distribution consisting of whole beads, partial beads and coarse to fine powder.

Dump the material into the coarsest strainer and shake until all the finer pieces go through into a collection container below. The hole size in the coarse strainer should be small enough to retain any bead particles that still look like a part of a bead or larger. These are then put back into the grinder with additional new beads and reground. Particles that pass through the first strainer are poured into a second finer strainer. Anything that remains in the second strainer is saved as coarse particles. Whatever passes through is filtered by a third finer strainer. Particles retained in the third strainer are saved as medium and those that pass through are saved as fine. Bag and label each in plastic ziplock bags.

If you use calibrated sieves, you just stack the three sieves with the coarsest on top going to the finest on bottom followed by the pan. Then just pour the ground beads in the top sieve, shake and the particles will automatically distribute among the four containers, as long as you don't overload them with too much material. Remember that the particles retained in the top sieve go back in the grinder.

Take care in handling the fine particles, because static electricity will cause them to stick to everything they touch. They can become airborne if you blow on them – also not good to breathe them. When you are done, clean up the grinder and filters with a shop vacuum and then an air hose so different colored particles don't carry over and mix with the next batch.

Cutting the Recess for the Bead Particles

Prepare a recess for the bead particles by turning with a parting tool or cutting with a rotary tool with a carbide burr. Make the sides of the recess as vertical as possible so the dimensions will not change as you turn the bead particles flush with the surface. If you are cutting an accent ring, cut with a parting tool about 1/16" to 1/8" deep. If the bottom of the recess will be exposed by turning away the back side to expose the bead particles, such as in the side of a bowl (see Figure 2), you will have to cut the recess deeper so the bottom of the recess can be exposed before the turning gets too thin. Although it might seem that having both the recess exposed on both sides would make the piece fragile, I have made three pieces this way and none have failed.

Applying the Bead Particles

IMPORTANT - Before applying the particles, seal the recess with shellac or CA. If you do not seal the recess, the CA will soak into the wood and not bond the particles to the wood, so when you turn the particles flush, they will break out in large pieces. Try CA on a part of the wood that will be turned away to see if it will stain the wood deeply. Shallow stains can be turned or sanded away when you level the surface of the applied ground bead particles.

Stephen Hatcher suggested sealing the recess with black paint, which enhances the boundary between the inlay and the wood. Before spraying with the black paint from a spray can, I seal the entire face of the turning wherever the black spray will hit. This prevents the black paint from going into the wood grain, requiring you to sand or turn more aggressively.

If the back side of the recess will not be exposed later by turning, you can start filling the recess with larger particles, followed by finer particles as you get close to the top surface. If the back side is turned to expose the particle inlay, start filling the recess with fine particles, then add the larger particles, filling in the spaces between the larger particles with fine. Gently patting the fine particles with your finger will push them into the spaces between the larger particles to prevent voids. Then apply thin CA by dropping it on the particles until the particles in the recess are glued in place. This is easy to see as the CA makes the particles darker. If the recess is greater than 1/8" deep, fill it in multiple passes. If you apply CA to bead material greater than 1/8" thick the CA at the bottom may not cure, even though the top is cured. As a final pass, I add fine until they are proud of the surface and apply thin CA until the surface is "wet" and then cure with accelerator. Until you gain some experience with applying the particles, voids can be

a problem. Preventing voids is a learned technique, so practice on a test piece until you become proficient. You can always fill a void with more CA, either thin or thick, depending on the void size. However, if the void is large, it will produce a clear area with no particles, which is not attractive. It is better to add more fine ground bead particles, then apply thin CA.

As you fill the recess and apply CA, you must mist each layer of the CA with accelerator. Slight foaming is OK, since this can add visual interest.

Turning the Bead Particles

To turn the bead particles, use any turning tool to level the particles with the wood surface. **Be careful of accidentally touching the proud particle surface while the piece is turning** – it is like a 10 grit sandpaper and will cut you very easily. On the first cut you can scrape, but may find that this will pull or chip out larger particles leaving a surface void that will have to be filled. I have had better results with a bevel rubbing push cut started just before the recess, which seems less likely to break out particles that are proud of the surface. After the initial leveling cut, shear scraping works well.

Finishing the Piece

I have not had any problems with finishes on the CA/particle surface, although I often use a CA finish on smaller pieces. I have also had good results using water based urethanes and oil based wipe on poly finishes. For a high gloss finish, I apply several coats of finish and sand gently by hand with the finest grade of sandpaper that removes the dust nits and produces a uniformly frosty finish. I then use finer grade sandpaper up through 4000 grit and burnish with brown paper bag. Be careful that you do not sand through the finish. If you want a higher gloss, finish buff with white diamond.

Selecting Bead Colors

You can simulate lapis using a mixture of blue transparent or opaque mixed with a small amount of blue pearlescent and by randomly adding a few white, clear or black particles. Turquoise colored particles look more natural if a small amount of fine black is added randomly to simulate natural variations rather than having a single, uniform color. Black and purple produce an interesting granite appearance. Accent bands in platter rims and box tops look nice as a black band flanked by two smaller clear or white bands or vice versa. An irregular joint between a box top and an inserted wooden accent can be made uniform by cutting a ring that goes into both parts and fill it with fine black particles. Larger areas of a single color look more realistic by mixing small amounts of another slightly different color, again to simulate natural variations. Images can be created by applying realistic colors for each part of the image. The tree platters that Stephen Hatcher does are an outstanding example. By applying all the different colors before adding the CA, you can determine if you like it. If you don't like it, dump it out and start over. Worst case you have wasted a few minutes of your time and a couple of cents worth of ground beads.

Links to Vendors

Pony beads – www.ponybeadstore.com. Be sure and write the bead part number on the bag of beads. Because there are so many colors, this will make it easier to purchase replacement beads in the future.

Grinder - KRUPS F203 Electric Spice and Coffee Grinder with Stainless Steel Blades - https://www.amazon.com/KRUPS-Electric-Grinder-Stainless-3-Ounce/dp/B00004SPEU/ref=sr_1_4?s=kitchen&ie=UTF8&qid=1466173352&sr=1-4&keywords=coffee+grinder.

This grinder seems to grind beads reliably for me. However, I found that the beads broke out the bottom edge of the plastic top on the Krups unit. I tried coating the inside with a layer of epoxy, but it did not stick. I got the best results by putting a couple of layers of thick clear packing tape or duct tape around the inside as small pieces that overlapped so that the leading edge was covered by the trailing edge of the prior piece of tape (apply the tape in the opposite direction of the blade rotation). Otherwise the leading edge of the tape will peel up when it the beads circulate around the container.

Small food processors can also be used, although I have seen one food processor that looked similar to the one successfully used, but for some reason it absolutely would not grind beads. So, try a cheap one and if it works buy a couple more for future use. Grinding plastic beads is pretty tough on the processor or coffee grinder, so having a replacement is worthwhile.

Alumilite/Epoxy – Alumilite can be purchased from turntex.com. Smooth-On Epoxacast 690 from smooth-on.com or amazon.com. Actually most any clear epoxy should work.

Cheap strainers – Search Wal-Mart for strainers. Tea strainers for fine and sink strainers or anything else you can find for medium and coarse. Just remember that the holes in the first strainer must be small enough to stop any particles that look like a whole or partial beads.

Calibrated sieves – They can be purchased from www.affordablesieves.com/3-inch-sieves/. The three sizes I use are #8, #12 and #20. I also purchased a bottom pan. All the parts are 3” diameter, full height with a skirt so they stack. This will cost about \$100 for the set.

This is a very easy and inexpensive technique to try, so see what you can do with it.



TURNING 26

WITH JOSH REID

No
Photo
Available

Crush Grind Pepper Mills

Required Tools

- 4 jaw self-centering chuck
- Drive center
- Live center
- Spindle roughing gouge (or square carbide rougher)
- Diamond parting tool
- Thin parting tool
- 3/8" spindle gouge (or round or diamond point carbide)
- Sand paper (120-600 grit)
- 1/2" Skew
- Hack saw
- 2 part epoxy
- Drill chuck
- Drill bit extender
- Forstner bits: 15/16", 1", 1-9/16", 1-3/4"
- Sanding Pad with 120 grit
- Finish of choice (I prefer 3-6 coats of Waterlox, then buff with carnauba wax)
- Waste blocks
- Center finder or ruler
- Pencil
- Awl or center punch

Mounting the Blank

1. Mount a blank (2-3/4" square, 1" longer than the mechanism) between centers and rough turn the blank to round. Layout the Mill Head and Mill Body on the blank and part a 1/2" deep groove. (See Figure 1.)
2. Cut dovetail tenons #1, #2, and #3 as shown in Figure 1 for mounting in a chuck.
3. Part the Mill Head from the Mill Body.

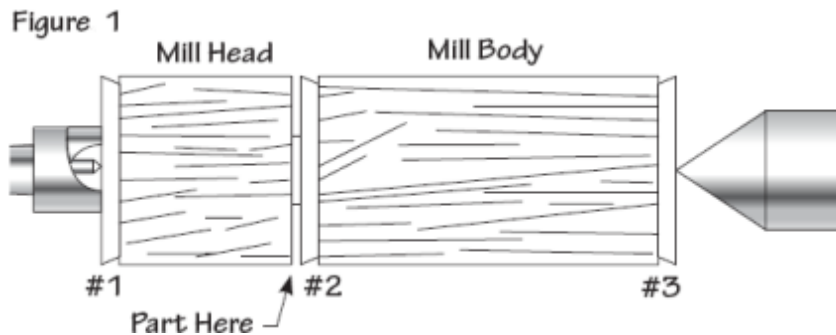

Drilling the Mill Head

1. Mount the Mill Head in a chuck using Tenon #1 and square the end of the blank.
2. Drill a 15/16" dia. hole 1-1/4" deep in the Mill Head.
3. Remove the Mill Head from the chuck.

Drilling the Mill Body

1. Mount the Mill Body in a chuck using Tenon #3 and square the end of the blank.
2. Drill a 1-1/16" dia. hole half way through the Mill Body.

3. Remove the Mill Body from the chuck and remount the Mill Body using Tenon #2. Square the end of the blank removing Tenon #3.
4. Drill a 1-3/4" dia. hole the depth of the forstner bit head.
5. Drill a 1-9/16" dia. hole the depth of the shaft on the forstner bit. (See Figure 2)
6. Finish drilling the 1" dia. hole completely through the rest of the Mill Body.
7. Sand the 1" dia. hole just a touch.
8. Remove the Mill Body from the lathe.

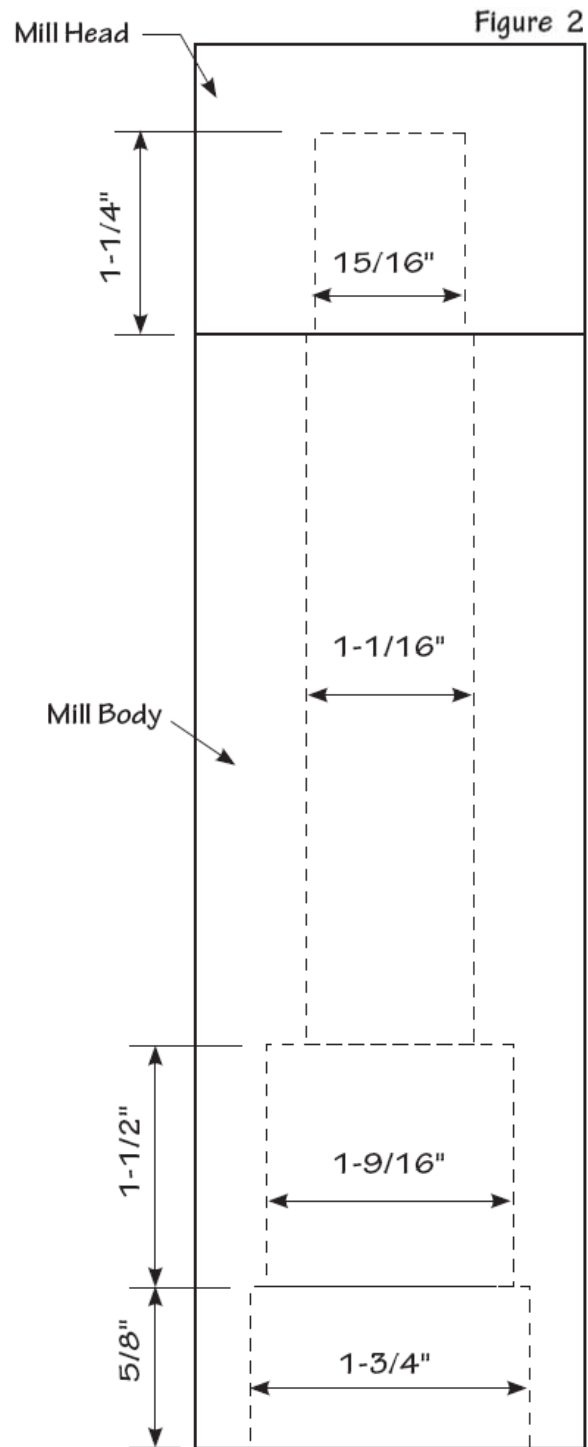

Finish Turning the Blank

1. Mount a 2" to 3" diameter by 2" thick waste block on the lathe with a chuck or faceplate. (See Figure 3)
2. Turn a $3/4\text{'}$ long tenon to fit very snugly into the $1\text{-}3/4\text{'}$ hole in the base of the Mill Body. Leave a small shoulder at the base of the tenon. Frequently test the fit of the tenon to the hole in the Mill Body until you have a snug fit.

3. Mount the Mill Body onto the drive tenon and bring the revolving center into the 1-1/16" hole for support. (See Figure 3)

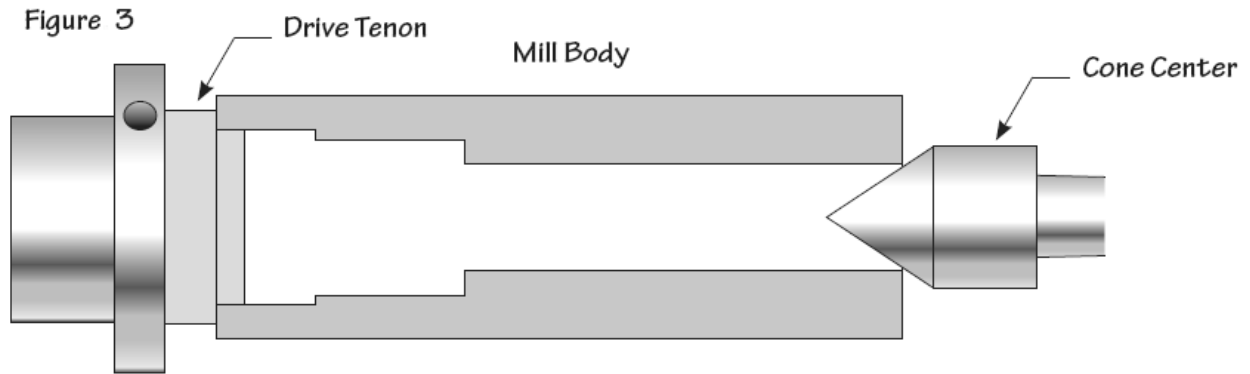

4. Turn the body to shape making sure not to run the wall too thin. Sand and finish the blank. (See Sample Shapes)

Turning the Mill Head

1. Mount a 2" to 3" diameter by 2" thick waste block on the lathe with a chuck or faceplate.
2. Turn a 3/4" long tenon to fit very snugly into the 15/16" dia. hole in the mill head. Leave a small shoulder at the base of the tenon. Frequently test the fit of the tenon to the hole in the Mill Body until you have a snug fit.
3. Mount the head onto the drive tenon and bring the revolving center up against the blank for support. (See Figure 4)

Sample Shapes

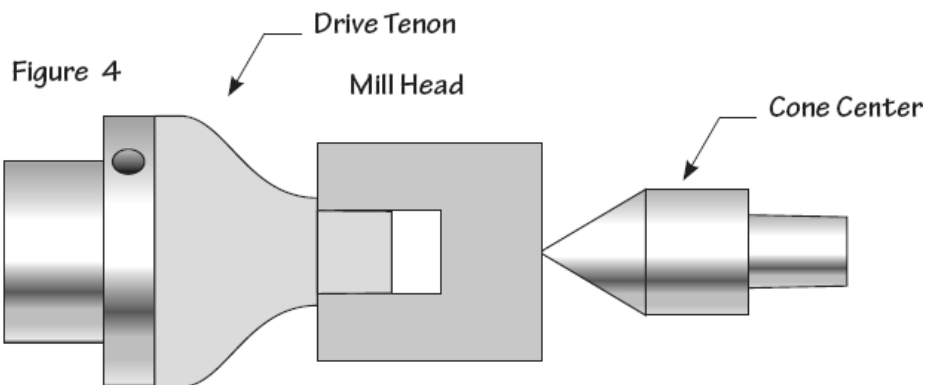
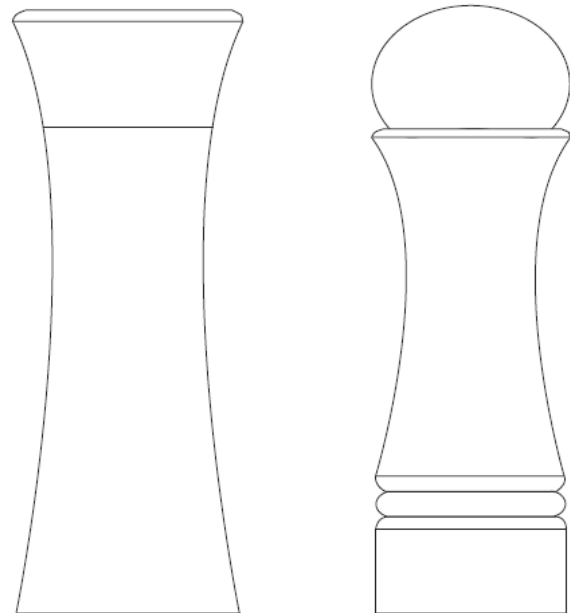

4. Turn the Mill Head to shape. Remove the revolving center, then sand and finish.

Assembly

1. In order to ensure a secure fit during assembly we recommend that the mechanism be glued in place with epoxy.
2. Lightly coat the inside wall of the hole in the Mill Head with epoxy. Press the stopper into the hole and set it aside until the epoxy cures.
3. Cut off the two clips on the top of the mechanism. (See Figure 5)
4. Lightly coat the inside wall of the 1-9/16" hole in the Mill Body base with epoxy. Press the mechanism into the hole and set it aside until the epoxy cures. Make sure that the epoxy does not interfere with any moving parts. Using a hacksaw, cut the hex shaft to length leaving 1-1/8" of the shaft extending out of the Mill Body.
5. Press the stopper and head onto the hex shaft until the head and body are touching. The shoulder of the stopper will center the head with the body of the mill.

How the Mill Works

The mill coarseness is adjusted by turning the small wheel on the bottom of the mechanism. To fill the mill with pepper or salt, pull the mill top off and fill from the top.

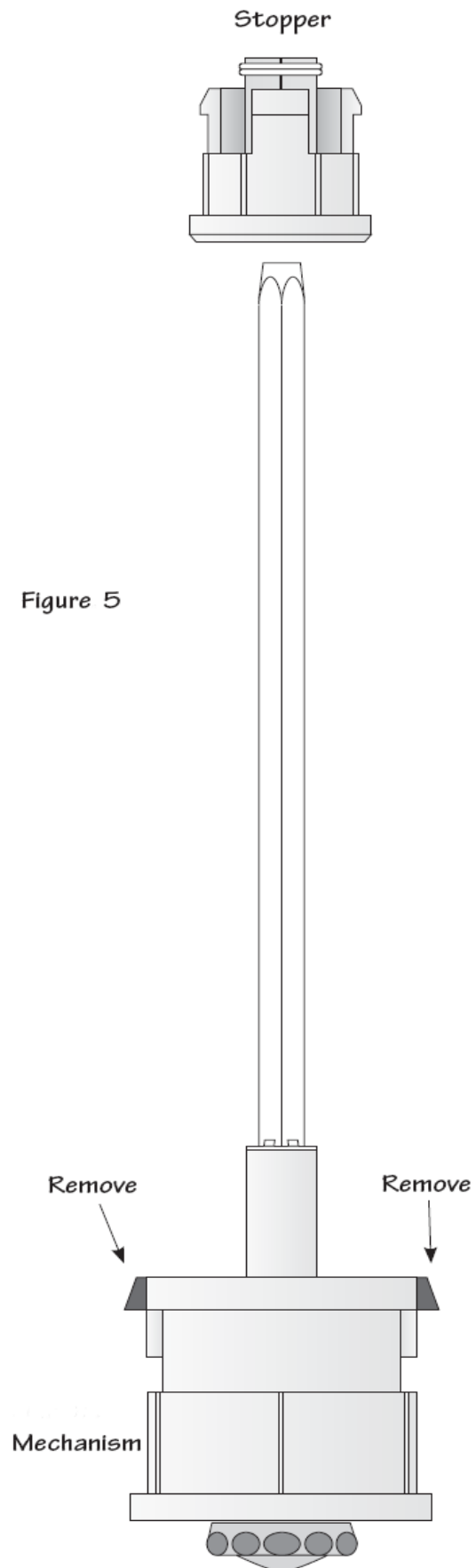

Figure 5



TURNING 26 WITH CURTIS SEEBECK



The Science & Art of Stabilizing Wood & Other Porous Materials

Stabilizing is the process of impregnating wood or other porous material with a resin to improve its density, durability, hardness, and resistance to moisture as well as adding color. Adding stabilizing to your woodturning bag of tricks can help you salvage punky wood and reduce tear out while also adding color. Stabilizing can be attempted with various different resins but the generally accepted best method is with a heat cured resin and vacuum. This demonstration will focus on vacuum and how it relates to stabilizing, vacuum pump selection, vacuum chambers, and procedures for stabilizing wood and other porous materials to improve their workability and durability.

Items Needed

- Heat cured stabilizing resin
- Vacuum chamber
- Vacuum pump capable of achieving a minimum of 29" Hg at sea level or 100 microns. Higher vacuum will produce better stabilized blanks. (I highly recommend an electric rotary vane vacuum pump since it may take over an hour of vacuum to fully evacuate the blanks of air)
- Small toaster oven (often available at second hand stores for around \$10)
- Aluminum foil
- Material to be stabilized (10% moisture content or less, preferably 0%)
- Personal protection equipment including latex or nitrile gloves and eye protection

Quick Start Basics

1. Prepare blanks
2. Place blanks in vacuum chamber and weight down
3. Add resin to completely cover blanks
4. Apply full vacuum to chamber until bubbles stop
5. Remove blanks
6. Wrap in foil
7. Cure at 200° F (93° C) for 1 - 1.5 hours
8. Remove foil
9. Allow to cool at room temperature

Preparation

The first thing is to make sure your material is less than 10% moisture content and clean. Oven dry (0% moisture) blanks are best if possible. If you do not have a moisture meter, don't worry! An easy way to assure your wood blanks are as dry as possible is to place your air-dried material in your toaster oven at 217° for 24 hours. Then remove the blanks from the oven and place them in a ziplock bag or sealed container to cool to room temperature. Placing them in the sealed container prevents them from picking up moisture from the air as they cool down. **If**

your blanks are hot when you add the resin, it will cause premature polymerization and you will have complete failure!

Add Resin

Next, place your blanks in a vacuum chamber and weigh them down so they won't float. Vacuum chambers are available on the internet or you can make your own from pickle jars all the way up to large stainless steel pots with a clear lid. Add the necessary amount of resin to the stabilizing chamber so that the blanks are completely submerged with about 1" (25.4 mm) of resin covering the blanks. Make sure your stabilizing chamber is in a secure, stable location. A vacuum chamber under vacuum may implode if exposed to sudden shock such as hitting the floor!

Coloring the Resin

Most stabilizing resins can be dyed when you want to add color to the wood. I have tried various different dyes and have had the best success with Alumilite reactive dyes. They are very concentrated and produce nice, vivid colors that mix and work well with the resin. Some dyes such as Transtint can be used in small amounts but if you add too much, it can affect the way the resin cures. With Alumilite dyes, I have not had any issues with it affecting the cure of the resin. When adding dyes, remember, you have to overcome the color of the wood so be sure to add plenty of dye. For example, if you are doing a white colored wood such as spalted hackberry with blue dye, in order to get a nice rich blue, the dyed resin will need to be very dark with a high concentration of dye to the point it looks black.

Apply Vacuum

After the resin has been added to the chamber, place the lid on the chamber and turn on your vacuum pump. When you initially start the vacuum, you will be pulling an extraordinary amount of air out of the blanks which will cause the resin to foam up considerably. It is best to have a valve to control the amount of vacuum in the beginning. Open the control valve completely before starting the pump and slowly close it, keeping the foam under control. After the major foaming has subsided, apply full vacuum.

Depending on the wood you are stabilizing and the vacuum pump you are using, it could take anywhere from 30 minutes to many hours to fully evacuate the air. Having a clear chamber is best but a chamber with a clear lid will also work and will allow you to see what is going on inside. Keep the vacuum going until you see very few bubbles coming from the blanks. I do not recommend shutting off the pump and trying to hold vacuum. The pump needs to keep going so it continues to pull the air from the wood and evacuate it from the chamber. Don't worry, if you are using a rotary vane pump, they are made to run continuous and you will not hurt it!

After the bubbles have stopped, release the vacuum and turn off your pump. (It is really important to not shut off your pump while under vacuum if you are using a rotary vane pump. You may cause premature wear on your pump.) Allow the blanks to soak without vacuum for twice as long as you pulled vacuum, minimum. Some woods will benefit from an even longer soak time. Remember, the majority of the resin uptake occurs AFTER you release the vacuum. If you want to allow your blanks to soak longer, you can remove them from the chamber and soak them in a different container or a zip lock bag. This will also free up your chamber for further use.

Curing the Blanks

Remove the blanks from the resin after they soak. Allow the excess resin to drain from the blanks and then wrap them in aluminum foil. It is a good idea to wrap the blanks individually so that they don't become one solid mass once the resin cures. An easy way to do this is to roll

out a 2' (60 cm) piece of foil and start at one end, wrapping the first blank with one layer. Then add the second blank next to the first and wrap all of it again. Then add the third and repeat until all blanks are wrapped. Fold the ends over and you are ready for the oven. Wrapping in foil is not absolutely required but will help contain any resin that bleeds out of the material.

Now place the wrapped blanks in an oven pre - heated to 200° F (93° C). Be sure to check the actual temperature of you toaster oven with an oven thermometer. The dials on toaster ovens are notoriously inaccurate. Too hot will not harm the resin but will cause more of it to "bleed" out of the blank before it cures. The internal temperature of the blank needs to reach 200° F (93° C) for a minimum of 10 minutes for the resin to cure. This usually takes around 1 - 1.5 hours for the typical pen blank but may take longer for thicker material. It does not hurt to leave the blanks in the oven even longer. I have left blanks in the oven for 5 days by accident with no ill effects. Be aware that if you take them out too soon and allow them to cool and find the resin has not cured, you have basically wasted that piece of wood. Once you interrupt the polymerization process by letting it cool down, you cannot successfully re-start it by putting it back in the oven. It is best to err on the side of caution and cure them longer until you get a better feel for the process. One way to be sure of proper polymerization is to put on some good gloves and remove the blanks from the oven. Peel back some of the foil and if you see any liquid resin, immediately wrap them back up and put them back in for another hour without allowing them to cool down.

Finishing Up

Once the blanks are finished curing, remove them from the oven with gloves and un - wrap the foil. I find the foil comes off easier while they are still hot. Allow the blanks to cool to room temperature and then you can scrape off the resin that has bled out of the blank or clean it up on a saw. This step is not required, but it will help you see the finished blank better to determine how you want to use it. A belt sander also does a great job.

Cleaning the Chamber and Storing Your Resin

When finished with the stabilizing process, pour the excess resin from the chamber and save it for later use. Most heat-cured resins are reusable over and over. I use quart plastic paint mixing cups with lids that you can buy in the paint section at your local home improvement store to store my resin. Be sure to store any unused resin in a cool place below 85° F. A shop refrigerator will greatly increase the shelf life and keep your resin fresh. Once the excess resin has been removed, simply wash out the chamber with dish soap, water, and a rag. Be sure to allow it to dry completely before your next use.



TURNING 26 **WITH JIM TANKSLEY**



How to Turn Natural Edge End Grain Mesquite Bowls



Finding the log

I cut my wood on a large ranch in West Texas. I prefer cutting the tree before they leaf out in January or February. I think it improves the chances of the bark staying on when turning a bowl. I look for large trees with character and possible burls. I avoid trees that are mostly dead already full of bores.

Cutting the log

I cut up the log in the field to various lengths depending on the size of the branch or trunk. Small branches 4 to 6 inches' diameter are used for turning Christmas Trees or Snow Men. Medium sizes 8 to 12 inches are cut for vases or urns. Larger sizes 13 inches and up are cut either for side grain or end grain bowls.

Storing the log

I seal the ends with anchor seal and spray the wood with Tim-bor or Termite Insecticide to kill the bores. I store the wood in a barn with a dirt floor. It will stay green for at least 2 years.

Determining bowl design

I look at the wood and envision a bowl based on the inclusions, cracks, bark, and shape.

Tools needed

I use many tools to turn an end grained bowl. Four jaw chuck, face plate, various tool rest with the main tool is a 5/8" bowl gouge with a 40 /40 grid. I also use a spindle roughing gouge to remove the bark, hollowing tools, beading /parting tool, and various scrapers are sometimes necessary depending on the shape and complexity of the bowl.



Turning the bowl

- a. Attach the face plate to what will be the top of the bowl
- b. Shape the bottom of the bowl
- c. Prepare the tendon for the four jaw chuck
 1. Ensure the live center indentation in center of the bowls tendon
 2. Shape to match jaws (straight or dovetail)
 3. Avoid bottoming out
- d. Cut the top edge of the bowl and rim
- e. Hollow the inside of the bowl
- f. Scape and sand smooth
- g. Remove the bowl from the chuck
- h. Using a jam chuck reverse the bowl and secure with live center in the center of tendon.
- i. Using very delicate cuts remove the tendon and turn a feature on the bottom of the bowl.
- j. Sand the bottom on the lathe
- k. Sand or chisel off the nub once the bowl is off the lathe

Finishing

- a. Soak the bowl in Danish Oil and let dry over night
- b. Spray bowl with Deft Clear Wood Finish





TURNING 26 WITH MOLLY WINTON



Making Mini Vessels & Carving Texture Pyrography Tips & Tricks

- Pyrography Tips and tricks—Using commercially made pyrography pens as well as nichrome wire and making a brand out of a copper rivet.
- Making Mini Vessels and Carving Textures— using a spindle gouge, detail gouge, and homemade allen wrench hollowers, then carved and textured.

Bibliography of Reference Material Equipment & Supply Recommendations

Form/Design

Ceramic Form, Design and Decoration, Revised Edition; Lane, Peter; ISBN 0-8478-2113-7

Art Forms in Nature; Haeckel, Ernst; ISBN 0-486-22987-4

Artist's Photo Reference, Reflections, Textures & Backgrounds; Greene, Gary;
ISBN 1-58180-377-X

Fourteen Families in Pueblo Pottery; Dillingham, Rick; ISBN 0-8263-1499-6

Seven Families in Pueblo Pottery; Maxwell Museum of Anthropology, University of New Mexico;
ISBN 0-8263-0388-9

1000 Great Motifs for Crafters; ISBN 978-1-843403-95-1

1000 Great Glass Painters Motifs; ISBN 978-843403-96-8

Great Book of Tattoo Designs; Lora Irish

www.doverpublications.com for pattern books

www.tanglepatterns.com for Zentangle designs

Pyrography

The Complete Pyrography; Poole, Stephen; ISBN 0-946819-76-9

Great Book of Woodburning; Irish, Lora; ISBN-10: 1-56523-287-9

Pyrography Workbook: A Complete Guide to the Art of Woodburning; Walters, Sue;
ISBN-10: 1565232585

Gourd Pyrography; Widess, Jim; ISBN-10: 1402745028

Wood Carving Illustrated, How to Magazine for Carvers; Issue No. 31, Summer 2005
(available while supplies last from Treeline USA 1-800-598-2743)

www.pyrographyonline.com

Pyrography Special Issue; pyrographyonline.com, Fox Chapel Publishing *My FAVORITE!!

Pyrography 2012; pyrographyonline.com, Fox Chapel Publishing

Gourd Art

The Gourd Magazine; The American Gourd Society; www.americangourdsociety.org

Beyond the Basics, Gourd Art; Macfarlane, David; ISBN 1-4027-1060-7

Glorious Gourd Decorating; Baskett, Mickey; ISBN 0-8069-6945-8

Carving

Carving on Turning; Pye, Chris; ISBN 0-946819-88-2

Wildlife Carving in Relief, Carving Techniques and Patterns; Irish, Lora; ISBN 1-56523-136-8

Equipment & Supply Recommendations

Nichrome Wire source: http://jacobs-online.biz/nichrome_wire.htm (20 & 22 gauge)

Recommended pyrography unit: **Burnmaster Eagle or Hawk** Source: www.packardwoodworks.com; www.woodworldtx.com and www.woodcarverssupply.com

Commercially made tip for line drawing and outlining (skew): (with little to no gap between the wires at the tip of the pen). It should look like a scalpel/knife. Looks like this:



The one pictured is made by Detail Master, which is no longer made, however all pen manufacturers have tips with similar profiles. You can buy just the tip at a significant price break as compared to tips that come fixed to a pen body. Source for the skew, and various other specialty tips: Razertip.com; woodburning.com (Colwood); woodcarverssupply.com

Burnmaster Replaceable Tip Pen, (available from www.packardwoodworks.com; www.woodworldtx.com; and www.woodcarverssupply.com)

Benchtop Solder Smoke Absorber www.amazon.com

Solder Smoke Fume Absorber **Replacement Filters** www.amazon.com

Rotary carver: Mastercarver Micro-Pro Source: www.packardwoodworks.com ; www.woodworldtx.com & www.woodcarverssupply.com

Reciprocating carver: Proxxon, Automach. Flexcut Detail Gouge Set & Roughing Gouge Set

Dremel engraver for texturing

Calipers for small vessels and Christmas ornaments: johntolly@austin.rr.com

Micro-Mark, The Small Tool Specialists: www.micromark.com Specialty pliers, mandrels, etc.

Rotary carving burrs:

www.riogrande.com or 1-800-545-6566

- Steel ball cutters
- Diamond ball cutters
- 3M Scotch-Brite Radial Bristle Discs
- Cup burrs

www.mdiwoodcarvers.com

- Stump cutter #20-B5
- Mini stump cutters #21-SET 36 & #21-SET 39
- Typhoon bur #37-3F1Y

Embellishment Supplies

www.**welburngourdfarm.com** and www.**gourdmasterproducts.com**

- Formula 49 (Ink dye medium); ink dyes; heat activated glue; fine tip applicators

www.**rangerink.com** also found at Michaels, JoAnn Fabrics, Hobby Lobby

- Distress Stain; Perfect Pearls Mist; Liquid Pearls

www.**tsukineko.com** also found at Michaels and JoAnn Fabrics

- DewDrop Brilliance Ink pads **must be heat set to dry

www.**clearsnap.com** also found at Michaels and JoAnn Fabrics

- Color Box ink pads **must be heat set to dry

www.**jacquardproducts.com** also found at Michaels and JoAnn Fabrics

- Pearl Ex powder pigments

www.**stewartsuperior.com** (may be able to arrange group purchase rather than buying through Welburn or GourdMaster Products—see above)

- Memories Dye Ink **must be heat set to dry

www.**decoart.com** also Hobby Lobby, Michaels

- Texture Terra Cotta; other faux finishes

www.**gilderspaste.com** also in many art stores, Craft Supplies USA, and Amazon

- Baroque Art Gilders Paste

Gesso by Golden or Liquitex found anywhere acrylic paints are sold (i.e., Michaels/Hobby Lobby/JoAnn Fabrics.) Black, white, and clear (to mix with acrylic paint for unlimited color varieties.

- Copper rivets or nails (solid copper, not plated) can be found at marine supply; roofing supply; and farrier supply.