

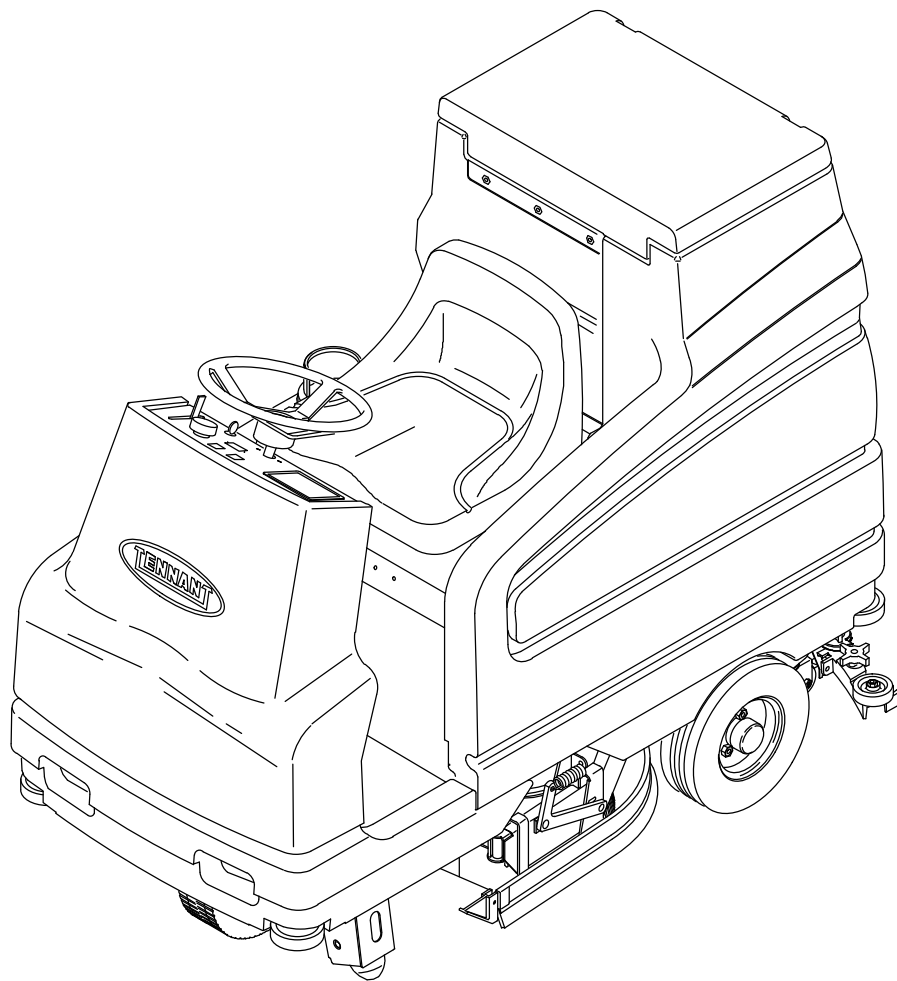

# 7100

Service Manual



330695  
Rev. 02 (8-11)



This service manual is intended to be an aid for the disassembly and reassembly of your TENNANT Model 7100.

The set is organized into Four major groups: General Information, Chassis, Scrubbing, and Electrical.

**General Information:** Safety precautions, machine transport, machine jacking, machine storage, chassis lubrication, machine specifications, and machine maintenance chart.

**Chassis:** Tire/wheel replacement, brake adjustment and replacement, steering adjustment and replacement, and machine cab information.

**Scrubbing:** Scrub head repair/replacement, brush repair/replacement, skirt/seal repair/replacement, squeegee repair/replacement, solution and recovery tank repair/replacement, and scrubbing troubleshooting.

**Electrical:** Battery maintenance and replacement, electrical schematics, and electrical troubleshooting.

Manual Number – 330695

Revision: 02

Published: 8-11

Copyright © 2011 TENNANT, Printed in U.S.A.

**CONTENTS**

	Page
SAFETY PRECAUTIONS .....	1-3
SPECIFICATIONS .....	1-7
GENERAL MACHINE	
DIMENSIONS/CAPACITIES .....	1-7
GENERAL MACHINE PERFORMANCE	1-7
POWER TYPE .....	1-8
TIRES . . . . .	1-8
MACHINE DIMENSIONS .....	1-9
MAINTENANCE .....	1-10
MAINTENANCE CHART .....	1-11
PUSHING, TOWING, AND TRANSPORTING	
THE MACHINE .....	1-12
PUSHING OR TOWING THE	
MACHINE .....	1-12
TRANSPORTING THE MACHINE	1-12
MACHINE JACKING .....	1-14
STORAGE INFORMATION .....	1-15
FREEZE PROTECTION .....	1-15
HARDWARE INFORMATION .....	1-16
STANDARD BOLT TORQUE CHART	1-16
METRIC BOLT TORQUE CHART ...	1-16
BOLT IDENTIFICATION .....	1-16
THREAD SEALANT AND LOCKING	
COMPOUNDS .....	1-16



## SAFETY PRECAUTIONS

The following symbols are used throughout this manual as indicated in their description:



**WARNING: To warn of hazards or unsafe practices that could result in severe personal injury or death.**

**FOR SAFETY: To identify actions that must be followed for safe operation of equipment.**

This machine is designed solely for scrubbing dirt and dust in an indoor environment. Tennant does not recommend using this machine in any other environment.

The following information signals potentially dangerous conditions to the operator or equipment. Read this manual carefully. Know when these conditions can exist. Locate all safety devices on the machine. Then, take necessary steps to train machine operating personnel. Report machine damage or faulty operation immediately. Do not use the machine if it is not in proper operating condition.



**WARNING: Batteries emit hydrogen gas. Explosion or fire can result. Keep sparks and open flame away. Keep covers open when charging.**



**WARNING: Flammable materials can cause an explosion or fire. Do not use flammable materials in tank(s).**



**WARNING: Flammable materials or reactive metals can cause explosion or fire. Do not pick up.**

## FOR SAFETY:

## 1. Do not operate machine:

- Unless trained and authorized.
- Unless operation manual is read and understood.
- Unless mentally and physically capable of following machine instructions.
- If not in proper operating condition.
- In flammable or explosive areas unless designed for use in those areas.

## 2. Before starting machine:

- Make sure all safety devices are in place and operate properly.
- Follow safety guidelines concerning wet floors.

- Check brakes and steering for proper operation (if so equipped).

## 3. When using machine:

- Go slow on inclines and slippery surfaces.
- Use care when backing machine.
- Report machine damage or faulty operation immediately.
- Keep children and unauthorized persons away from the machine when in use.
- Do not allow children to play on or around machine.
- Follow mixing and handling instructions on chemical containers.

## 4. Before leaving or servicing machine:

- Stop on level surface.
- Set parking brake (if equipped).
- Turn off machine and remove key.

## 5. When servicing machine:

- Avoid moving parts. Do not wear clothing or jewelry.
- Block machine tires before jacking machine up.
- Jack machine up at designated locations only. Block machine up with jack stands.
- Use hoist or jack that will support the weight of the machine.
- Wear protective gloves and eye protection when handling batteries and battery cables.
- Wear protective gloves and eye protection when handling vinegar.
- Disconnect battery connections before working on machine.
- Avoid contact with battery acid.
- All work must be done, having enough visibility and/or appropriate lighting.
- All repairs must be performed by a qualified service person.
- Do not power spray or hose off machine. Electrical malfunction may occur.
- Do not modify the machine from its original design.
- Use Tennant supplied or equivalent replacement parts.

### SAFETY PRECAUTIONS

6. When loading/unloading machine onto/off truck or trailer:
  - Turn off machine.
  - Use truck or trailer that will support the weight of the machine.
  - Use winch. Do not drive the machine onto/off the truck or trailer unless the load height is 380 mm (15 in) or less from the ground.
  - Set parking brake after machine is loaded.
  - Block machine tires.
  - Tie machine down to truck or trailer.

The safety labels appear on the machine in the locations indicated. If these or any label becomes damaged or illegible, install a new label in its place.

**BATTERY CHARGING LABEL – LOCATED ON AND UNDERNEATH THE SEAT SUPPORT.**



**FLAMMABLE MATERIALS LABEL – LOCATED ON THE UNDERSIDE OF THE TANK COVER AND ON THE LEFT SIDE OF THE OPERATOR COMPARTMENT.**



**FLAMMABLE SPILLS LABEL – LOCATED ON THE SEAT SUPPORT.**



**FOR SAFETY LABEL – LOCATED ON THE SEAT SUPPORT.**

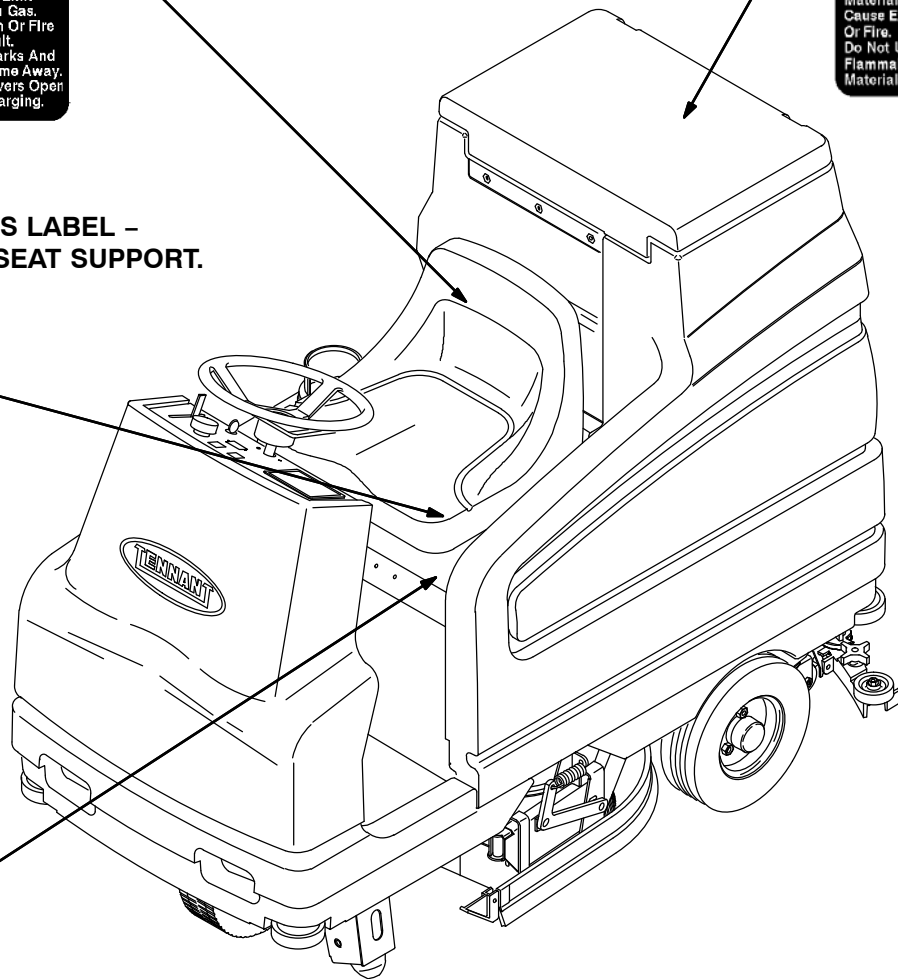

## GENERAL INFORMATION

### SPECIFICATIONS

#### GENERAL MACHINE DIMENSIONS/CAPACITIES

Item	Dimension/capacity
Length	1690 mm
Width (less squeegee)	820 mm
Height	1372 mm
Height with overhead guard	NA
Disk brush diameter for 700 mm (28 in) scrub head	355 mm
Disk brush diameter for 800 mm (32 in) scrub head	400 mm
Cylindrical brush diameter	150 mm
Cylindrical brush length for 700 mm (28 in) scrub head	700 mm
Cylindrical brush length for 800 mm (32 in) scrub head	800 mm
Squeegee width for 700 mm (28 in) scrub head	850 mm
Squeegee width for 800 mm (32 in) scrub head	1015 mm
Scrubbing path width for 700 mm (28 in) scrub head	700 mm
Scrubbing path width for 800 mm (32 in) scrub head	800 mm
Solution tank capacity	130 L
Recovery tank capacity	130 L
Sound level at operator ear	75 dBA
Vibration level at steering wheel does not exceed	2.5 m/s <sup>2</sup>
Vibration level at operator seat does not exceed	0.5 m/s <sup>2</sup>
Weight/net less batteries	387 Kg
Weight/with standard battery package	583 Kg
GVWR	930 Kg

#### GENERAL MACHINE PERFORMANCE

Item	Measure
Aisle turnaround width	1840 mm
Minimum Turning Radius	2527 mm
Travel Speed	7.2 Km
Maximum rated climb and descent angle with full tanks	4°/7%
Maximum rated climb and descent angle with empty tanks	11°/19%



**POWER TYPE**

Type	Quantity	Volts	Ah Rating	Weight
Batteries	6	6	244 @ 20 hr rate	32 kg (72 lb)

Type	Use	VDC	kW (hp)
Electric Motors	Scrub brush (disk)	36	0.60 (0.80)
	Scrub brush (cylindrical)	36	0.56 (0.75)
	Vacuum fan	36	0.6 (0.8)
	Propelling	36	1.2 (1.6)

Type	VDC	amp	Hz	Phase	VAC
Chargers (Smart)	36	30	60	1	120
	36	25	50	1	230
	36	25	50	1	245

**TIRES**

Location	Type	Size
Front (1)	Solid	90 mm wide x 300 mm OD (3.5 in wide x 11.8 in OD)
Rear (2)	Solid	90 mm wide x 310 mm OD (3.5 in wide x 12.3 in OD)

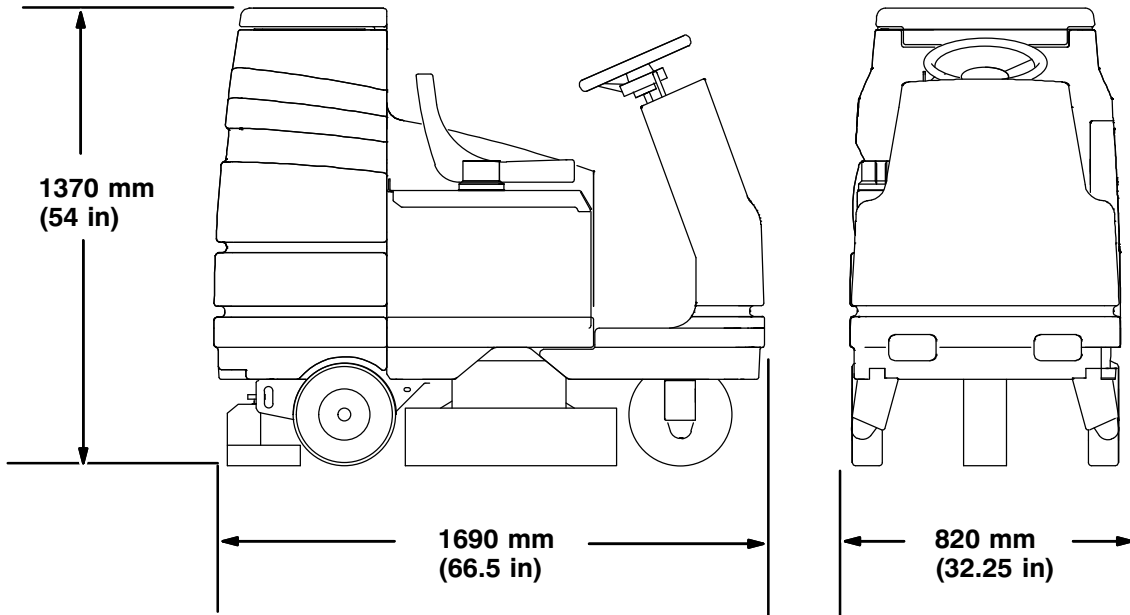
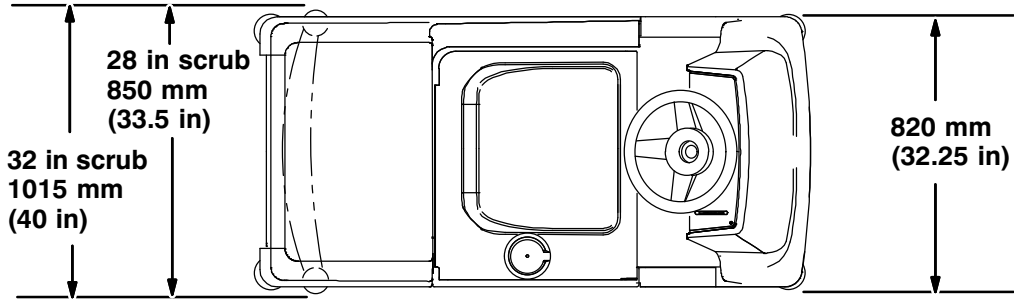

**MACHINE DIMENSIONS**

353475

MAINTENANCE

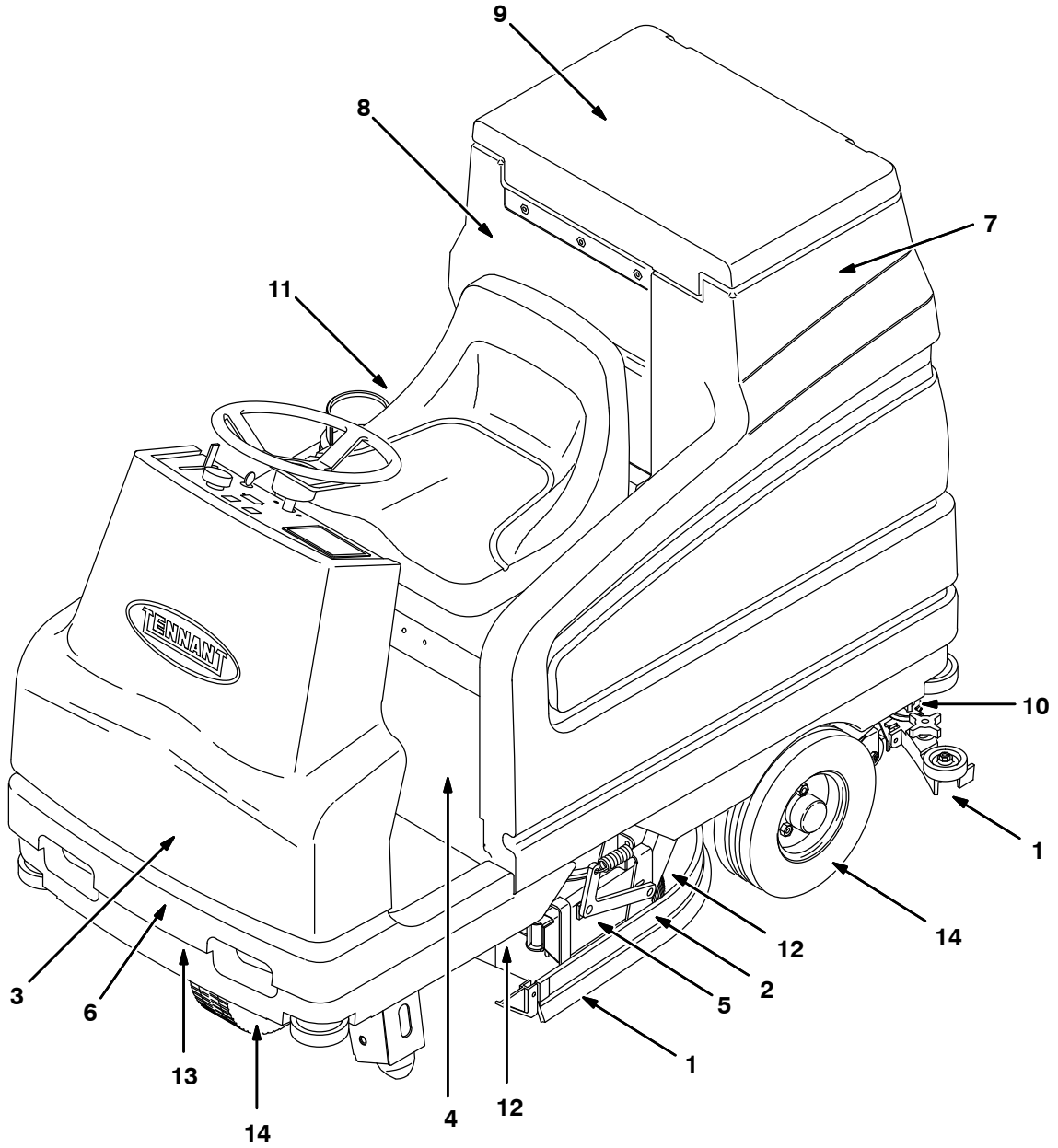

353450

# GENERAL INFORMATION

## MAINTENANCE CHART

Interval	Key	Description	Procedure	Lubricant/ Fluid	No. of Service Points
Daily	1	Side and rear squeegees	Check for damage and wear	–	3
			Check deflection and leveling	–	6
	2	Scrub brushes	Check for damage, wear, debris	–	2
	8	Recovery tank	Clean tank	–	1
	8	Recovery tank, ES™ mode	Clean ES™ filter	–	1
	7	Solution tank, ES™ mode	Clean solution supply filter	–	1
	9	Vacuum fan inlet filter	Clean	–	1
	–	Machine	Check for leaks	–	3
11	Cylindrical brushes only: debris trough	Clean	–	1	
50 Hours	5	Cylindrical brushes	Check taper and rotate front to rear	–	2
	10	Squeegee caster wheels and pivot points	Lubricate	SPL	4
	4	Battery cells	Check electrolyte level	DW	3
	12	Disk scrub head floor skirts	Check for damage and wear	–	2
100 Hours	5	Cylindrical scrub brush drive belts	Check tension	–	2
	3	Steering caster pivot bearing	Lubricate	SPL	1
	5	Scrub head lift bearings (option)	Lubricate	SPL	2
	9	Vacuum Fan and tank seals	Check for damage and wear	–	3
	14	Tires	Check for damage and wear	–	3
200 Hours	4	Battery terminals and cables	■ Check and clean	–	12
	13	Brake	Check adjustment	–	1
	6	Steering gear chain	Lubricate	GL	1
500 Hours	9	Vacuum fan motor(s)	Check motor brushes	–	1
		Steering gear chain	■ Check deflection	–	1
1000 Hours	5	Scrub brush motors	Check motor brushes	–	2
	6	Propelling motor	Check motor brushes	–	1

### LUBRICANT/FLUID

DW . . . Distilled water

SPL . . . Special lubricant, Lubriplate EMB grease (TENNANT part no. 01433–1)

GL . . . SAE 90 weight gear lubricant

*NOTE: Also check procedures indicated (■) after the first 50 hours of operation.*

---

## PUSHING, TOWING, AND TRANSPORTING THE MACHINE

---

### PUSHING OR TOWING THE MACHINE

If the machine becomes disabled, it can be pushed from the front or rear, but only tow it from the front.

Only push or tow the machine for a *very short distance* and do not exceed 3.2 kp/h. It is NOT intended to be pushed or towed for a long distance or at a high speed.

**ATTENTION! Do not push or tow machine for a long distance or damage may occur to the propelling system.**

### TRANSPORTING THE MACHINE

1. Position the front of the machine at the loading edge of the truck or trailer.

**FOR SAFETY: Use a truck or trailer that will support the weight of the machine.**

*NOTE: Empty the recovery and solution tanks before transporting the machine.*

2. If the loading surface is not horizontal or is higher than 380 mm from the ground, use a winch to load machine.

If the loading surface is horizontal AND is 380 mm or less from the ground, the machine may be driven onto the truck or trailer.

3. To winch the machine onto the truck or trailer, attach the winching chains to the front tie down locations. The front tie-down locations are on the front sides of the machine. Make sure the machine is centered.

**FOR SAFETY: When loading machine onto truck or trailer, use winch. Do not drive the machine onto the truck or trailer unless the loading surface is horizontal AND is 380 mm or less from the ground.**

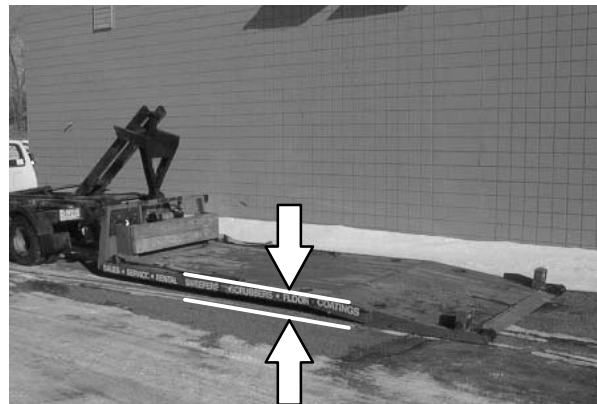

## GENERAL INFORMATION

4. Position the machine onto the truck or trailer as far as possible. If the machine starts to veer off the centerline of the truck or trailer, stop and turn the steering wheel to center the machine.
5. Set the parking brake, lower the scrub head and block the machine tires. Tie down the machine to the truck or trailer before transporting.

The front tie-down locations are on the front jack supports.

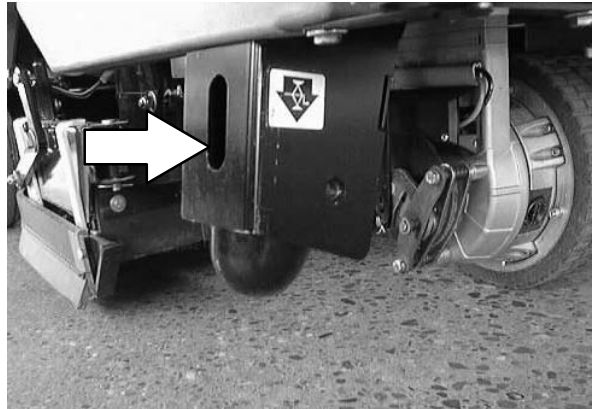

The rear tie-down locations are on the rear corners of the machine.

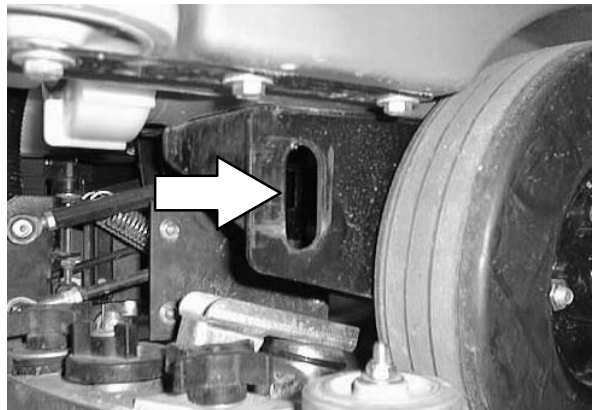

6. If the loading surface is not horizontal or is higher than 380 mm from the ground, use a winch to unload machine.

If the loading surface is horizontal AND is 380 mm or less from the ground, the machine may be driven off the truck or trailer.

**FOR SAFETY: When unloading machine off truck or trailer, use winch. Do not drive the machine off the truck or trailer unless the loading surface is horizontal AND 380 mm or less from the ground.**

### MACHINE JACKING

Jack up the machine from underneath all four corners of the machine. Use a piece of wood between the jack and frame to distribute the machine weight load.

Always stop the machine on a flat level surface and block the tires before jacking the machine up.

**FOR SAFETY: When servicing machine, block machine tires before jacking machine up.**

**FOR SAFETY: When servicing machine, jack machine up at designated locations only. Block machine up with jack stands.**

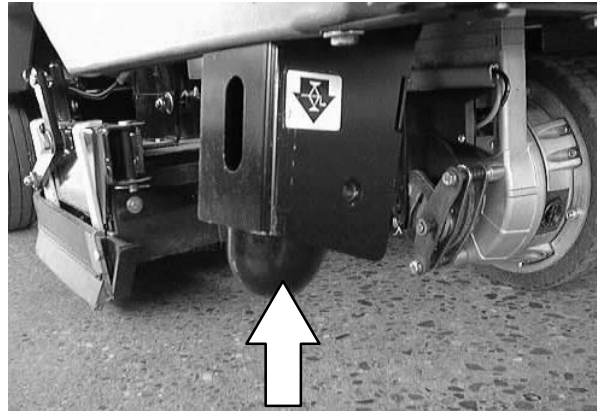

Jack up the rear of the machine from underneath the rear corners. Use a piece of wood between the jack and the frame to distribute the machine weight load.

**FOR SAFETY: When servicing machine, block machine tires before jacking machine up.**

**FOR SAFETY: When servicing machine, jack machine up at designated locations only. Block machine up with jack stands.**

### STORAGE INFORMATION

---

The following steps should be taken when storing the machine for extended periods of time.

1. Drain and clean the solution and recovery tanks.

ES™ machines: Run clean water through the solution system and the ES™ solution pump.

2. Park the machine in a cool, dry area.
3. Remove the batteries, or charge them every three months.

### FREEZE PROTECTION

1. Be sure the solution tank is empty.
2. Pour 3.8 L (1 gal) of pre-mixed automotive-type windshield washer solution into the solution tank.
3. Turn the machine power on.
4. Start the solution flow. Start the power wand solution system and ES™ system to circulate the washer solution through the components.
5. The washer solution does not need to be drained from the solution tank.



**HARDWARE INFORMATION**

The following charts state standard plated hardware tightening ranges for normal assembly applications. Decrease the specified torque by 20% when using a thread lubricant. Do not substitute lower grade hardware for higher grade hardware. If higher grade hardware than specified is substituted, tighten only to the specified hardware torque value to avoid damaging the threads of the part being threaded into, as when threading into speed nuts or weldments.

*NOTE: Decrease torque by 20% when using a thread lubricant.*





Exceptions to the above chart:

Check the machine for exceptions!

**STANDARD BOLT TORQUE CHART**

Thread Size	SAE Grade 5 Torque ft lb (Nm)	SAE Grade 8 Torque ft lb (Nm)
0.25 in	7–10 (9–14)	10–13 (14–38)
0.31 in	15–20 (20–27)	20–26 (27–35)
0.38 in	27–35 (37–47)	36–47 (49–64)
0.44 in	43–56 (58–76)	53–76 (72–103)
0.50 in	65–85 (88–115)	89–116 (121–157)
0.62 in	130–170 (176–231)	117–265 (159–359)
0.75 in	215–280 (291–380)	313–407 (424–552)
1.00 in	500–650 (678–881)	757–984 (1026–1334)

**BOLT IDENTIFICATION**

Identification Grade Marking	Specification and Grade
	SAE–Grade 5
	SAE–Grade 8
	ISO–Grade 8.8
	ISO–Grade 10.9

01395

**THREAD SEALANT AND LOCKING COMPOUNDS**

Thread sealants and locking compounds may be used on this machine. They include the following:

Loctite 515 sealant – gasket forming material. TENNANT Part No. 75567, 15 oz (440 ml) cartridge.

Loctite 242 blue – medium strength thread locking compound. TENNANT Part No. 32676, 0.5 ml tube.

Loctite 271 red – high strength thread locking compound. TENNANT Part No. 19857, 0.5 ml tube.

*NOTE: Decrease torque by 20% when using a thread lubricant.*

**METRIC BOLT TORQUE CHART**

Thread Size	Class 8.8 Torque ft lb (Nm)	Class 10.9 Torque ft lb (Nm)
M4	2 (3)	3 (4)
M5	4 (5)	6 (8)
M6	7 (9)	10 (14)
M8	18 (24)	25 (34)
M10	32 (43)	47 (64)
M12	58 (79)	83 (112)
M14	94 (127)	133 (180)
M16	144 (195)	196 (265)
M20	260 (352)	336 (455)
M24	470 (637)	664 (900)



## CONTENTS

	Page
INTRODUCTION .....	2-3
—BRAKES AND TIRES .....	2-4
SERVICE/PARKING BRAKE .....	2-4
TO ADJUST SERVICE/PARKING BRAKE (Serial Numbers 00000000–10160409) ...	2-4
TO REPLACE BRAKE PADS .....	2-5
TO DISASSEMBLE SERVICE/PARKING BRAKE (Serial Numbers 10160410–) .	2-6
REAR TIRES AND WHEELS .....	2-7
TO REPLACE REAR WHEEL HUB BEARINGS .....	2-7
—FRONT DRIVE WHEEL, AND WHEEL HOUSING SUPPORT .....	2-10
TO REMOVE FRONT DRIVE ASSEMBLY	2-10
TO INSTALL FRONT DRIVE ASSEMBLY	2-14
TO REPLACE FRONT TIRE .....	2-18
TO ADJUST STEERING CHAIN .....	2-24
TO REPLACE STEERING CHAIN .....	2-26
TO REPLACE STEERING HOUSING BEARINGS .....	2-29
TO REPLACE STEERING U-JOINT ....	2-35
TO REPLACE SMALL STEERING SPROCKET .....	2-37
TO REPLACE LARGE STEERING SPROCKET .....	2-40
TO REPLACE FRONT WHEEL PIVOT NEEDLE BEARING/THRUST WASHERS .....	2-44
TO REPLACE FRONT WHEEL HOUSING CONE BEARING .....	2-49



**INTRODUCTION**

This section includes information on the main chassis related components for example the front drive, steering, brakes and tires.

## BRAKES AND TIRES

### SERVICE/PARKING BRAKE

The service brake on the model 7100E consists of a single disc and caliper (serial numbers 00000000–10160409) or a friction–band style brake (serial numbers above 10160409). The service brake is located on the front tire and wheel assembly. The parking brake uses the same mechanism as the service brake. The service brake and parking brake are each actuated with a foot pedal.

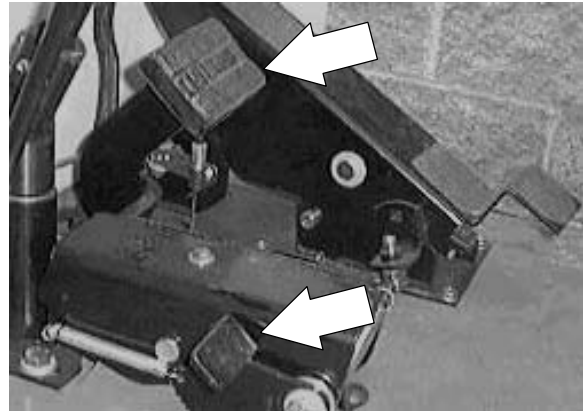

### TO ADJUST SERVICE/PARKING BRAKE (Serial Numbers 00000000–10160409)

**FOR SAFETY: Before Leaving Or Servicing Machine; Stop On Level Surface, place blocks in front and back of back wheels.**

1. If the service brake pedal has excessive movement before the brake is activated, the service brake needs to be adjusted.
2. Go under the front of the machine on the right side and locate the disc brake caliper assembly.



3. Remove the cotter pin from the brake lever pin. Move the brake arm to the next hole. Reinstall the cotter pin. Test the brake pedal for correct movement (less than an inch) to activate the brake caliper.

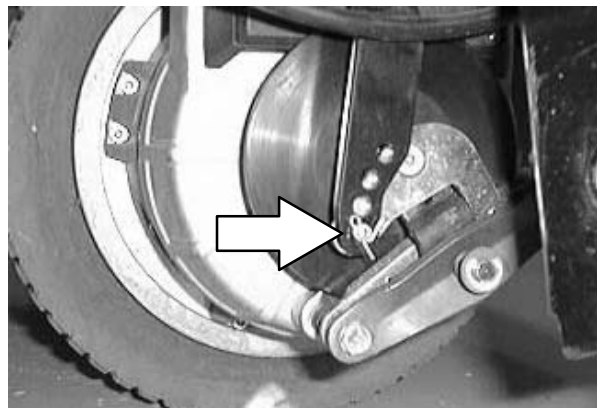

**TO REPLACE BRAKE PADS**

1. Go under the front of the machine on the right side and locate the disc brake caliper assembly. *Make sure the parking brake is NOT activated.*

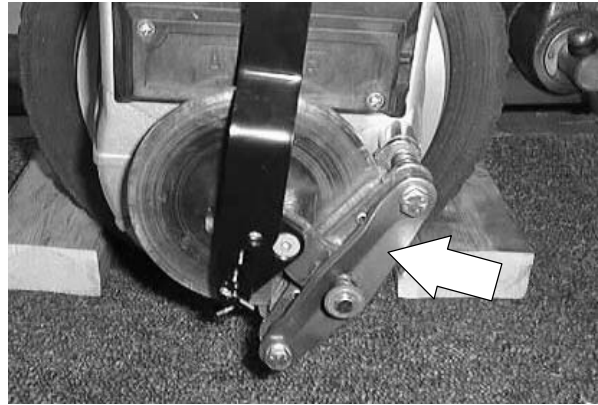

2. Remove the brake arm from the caliper arm.

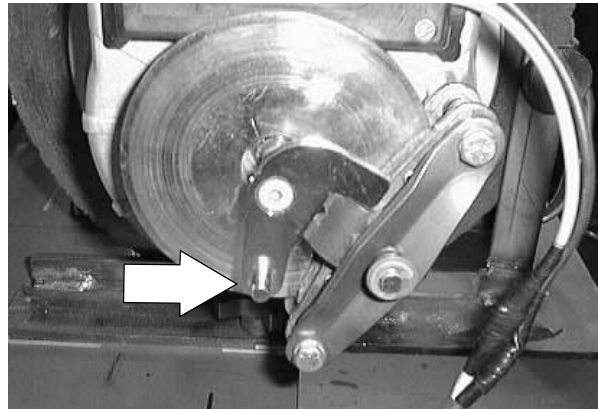

3. Remove the two hex screws holding the brake caliper assembly to the drive assembly.

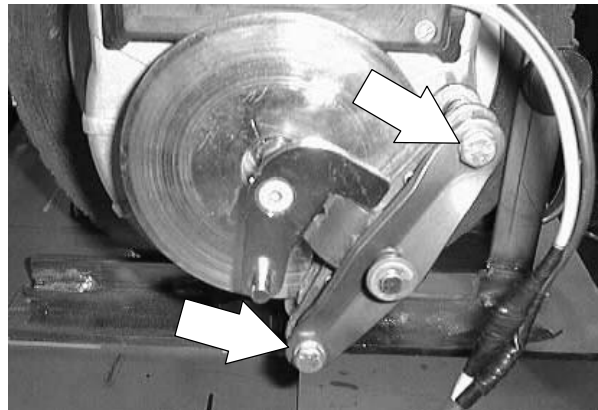

4. Remove the existing brake pads from the caliper assembly. Position the new brake pads onto the caliper assembly. *Make sure to reinstall the compression springs.*

5. Reinstall the brake caliper assembly onto the drive assembly. Reinstall the two hex screws and tighten to 18 – 24 Nm (15 – 20 ft lb.).

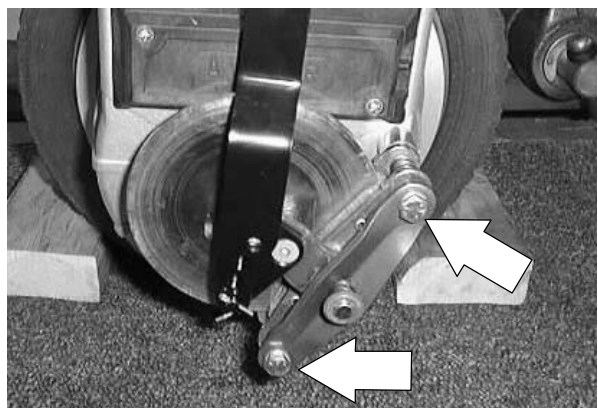

# CHASSIS

## TO DISASSEMBLE SERVICE/PARKING BRAKE (Serial Numbers 10160410- )

**FOR SAFETY: Before Leaving Or Servicing Machine; Stop On Level Surface, place blocks in front and back of back wheels.**

1. Remove left support with puller.
2. Remove 4 retaining rings and 2 pins.

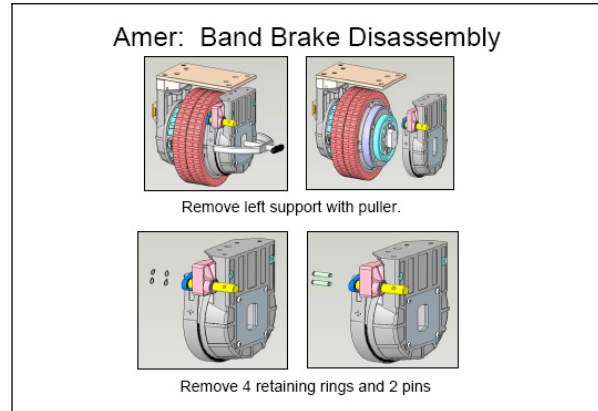

3. Make sure when assembling the new brake that the reference point is in the right position.
4. Check that the brake is correctly working, internally to the gearbox disk shoulder.

*NOTE: Clean carefully all the removed components and clean the gearbox disk where the break acts.*

*NOTE: Execute the operation in reverse for the new brake assembly, eventually using a plastic hammer to help the right insertion in the gearbox ball bearing seat.*

*NOTE: Check periodically that the working area of the break is clean from dust and dirt.*

*NOTE: Brake must be changed when it reaches a thickness of 2 mm.*

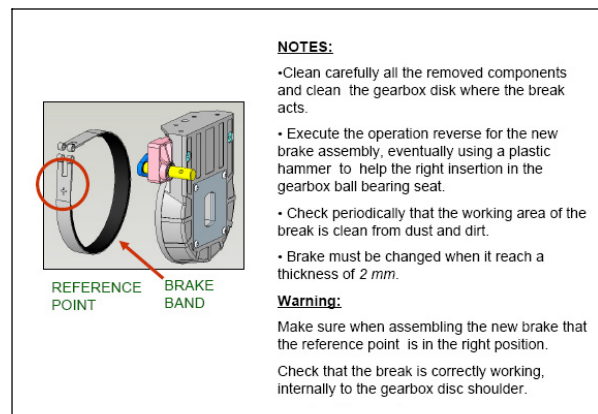



## REAR TIRES AND WHEELS

The rear tires on the 7100E are semi-pneumatic. The rear tires are free wheeling and have no braking capabilities.

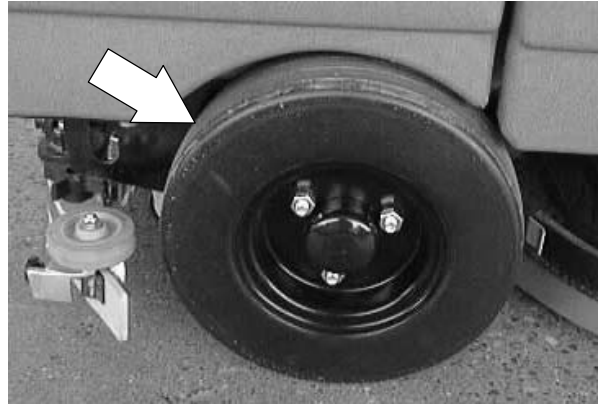

## TO REPLACE REAR WHEEL HUB BEARINGS

**FOR SAFETY: Before Leaving Or Servicing Machine; Stop On Level Surface, Set Parking Brake.**

1. Jack up the rear corner of the machine where the tire needs to be removed. Place a jack stand under the machine frame.

*NOTE: Do not raise both rear wheels off the floor at the same time. The machine will become unstable because of the single front tire.*



2. Remove the rubber boot covering the wheel bearing.

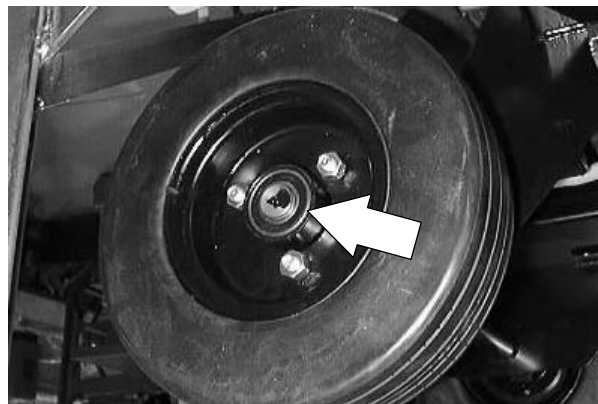

## CHASSIS

3. Remove the retainer ring holding the wheel hub and bearing to the axle shaft. Pull the tire and hub assembly off the axle shaft.

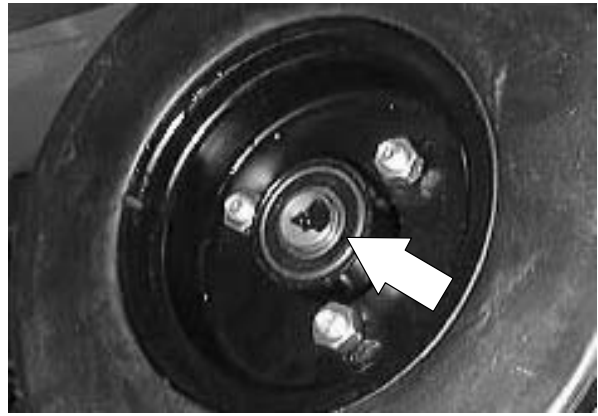

4. Remove the three nuts holding the tire and wheel to the hub. Remove the tire and wheel from the hub.



5. Use a hammer and punch to remove the existing hub bearings.

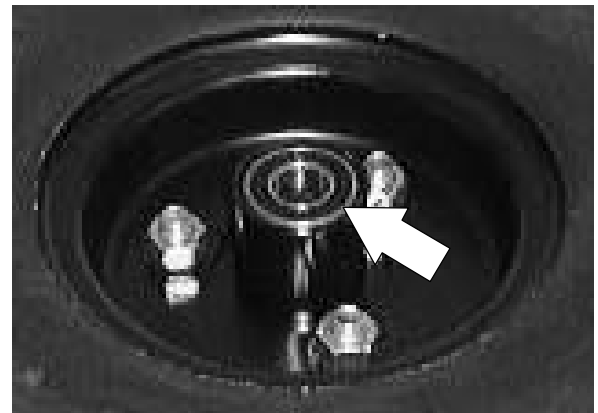

6. Use an arbor press to install the new hub bearings.

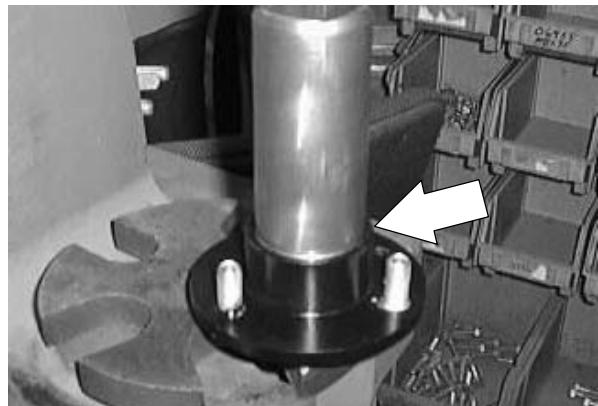

7. Reinstall the tire and wheel onto the hub (coining on wheel facing lug nuts). Tighten the three lug nuts to 58 – 76 Nm (43 – 56 ft lb).

*NOTE: The lug nuts must face the outside of the machine.*



8. Reinstall the wheel and hub assembly onto the axle shaft. *Make sure the axle shaft has a coating of grease applied before installing hub.* Reinstall the retaining ring onto the axle shaft.



9. Reinstall the rubber boot onto the wheel hub.



10. Remove the jack stand and lower the machine. Check the new wheel bearings for proper operation.

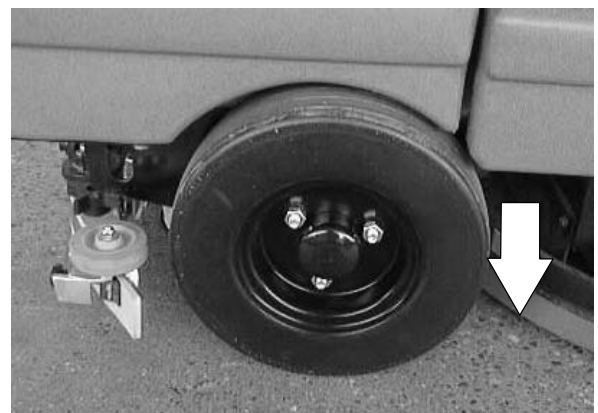

## CHASSIS

### FRONT DRIVE WHEEL, AND WHEEL HOUSING SUPPORT

The model 7100E is propelled forward and reverse by the front wheel assembly. An electric motor powers the front tire assembly.

The steering on the model 7100E is controlled by a steering wheel which turns a chain that is connected to the front wheel housing. The front wheel housing turns on a large bearing and rubber seal.

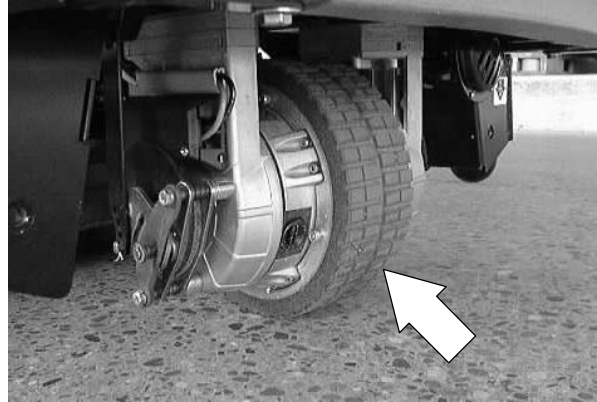

### TO REMOVE FRONT DRIVE ASSEMBLY

**FOR SAFETY: Before Leaving Or Servicing Machine; Stop On Level Surface, place blocks in front and back of the rear tires.**

1. Jack up the front of the machine at the jack point. Install jack stands under the machine frame.

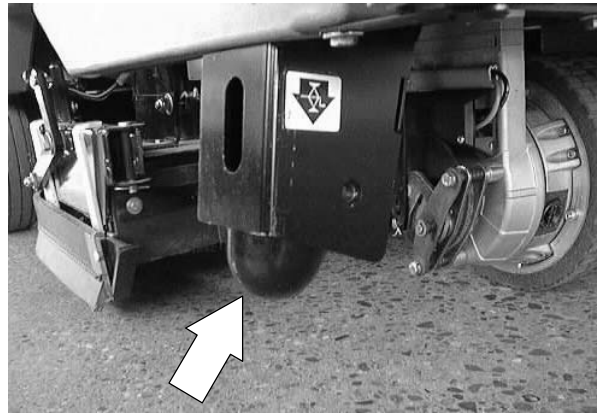

2. Raise the seat support and engage the prop rod.

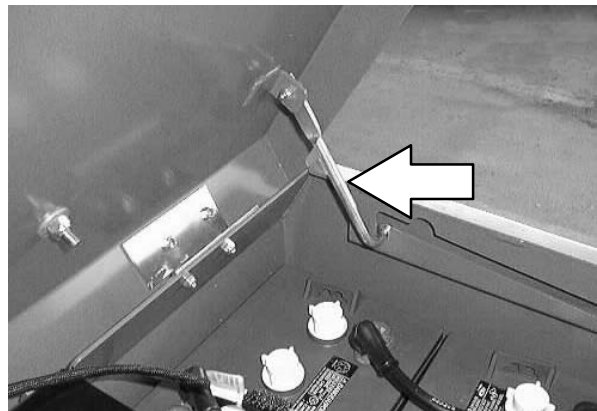

3. Disconnect the battery connector from the machine.

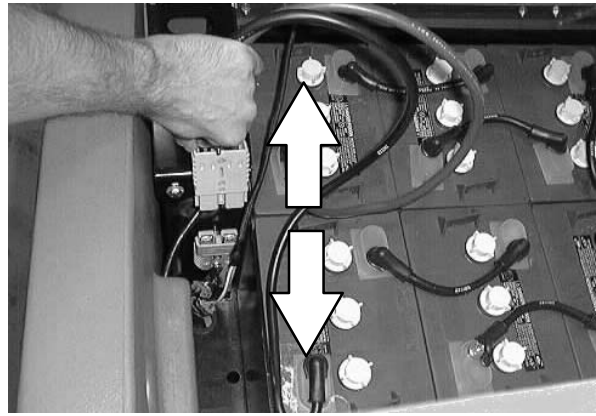

4. Go to the operators compartment and locate the two hex screws holding the steering bearing housing to the machine frame. Loosen the two screws and push the bearing housing back in the slots. *This will loosen the steering chain.*

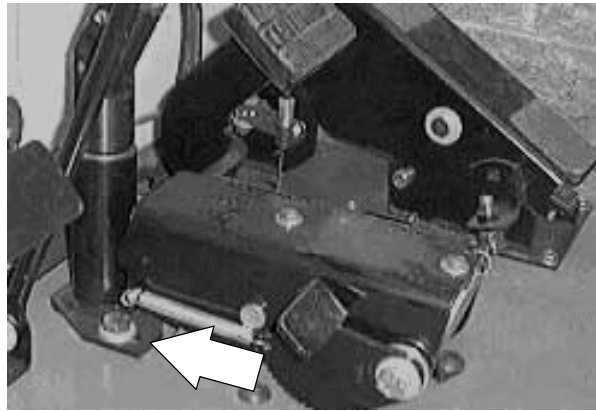

5. Locate the master link on the steering chain. Remove the master link from the steering chain. Remove the steering chain from the machine.

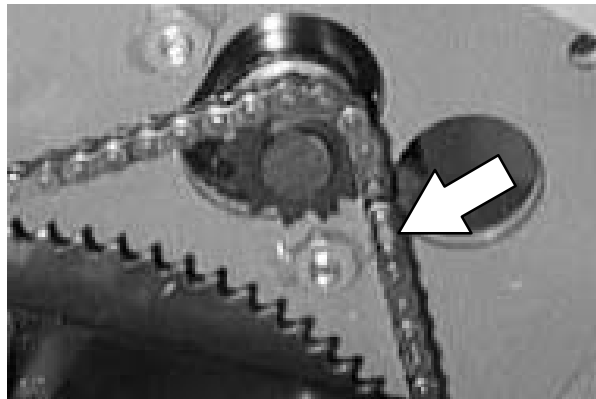

6. Remove the power wire cover from the side of the drive assembly.

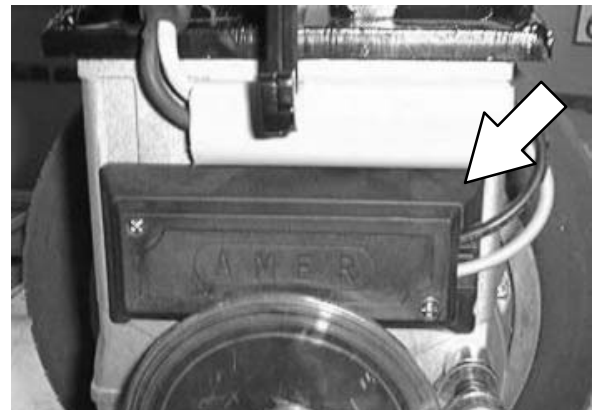

## CHASSIS

7. Mark then disconnect the wires leading to the drive assembly motor.

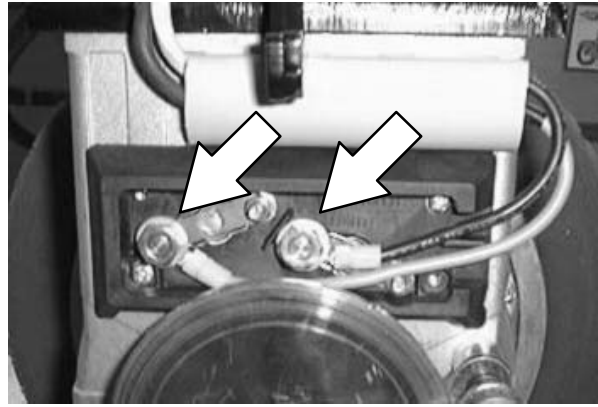

8. Remove the motor wire clamp. Pull the wire out of the plastic sleeve. Remove the wire from the drive assembly.

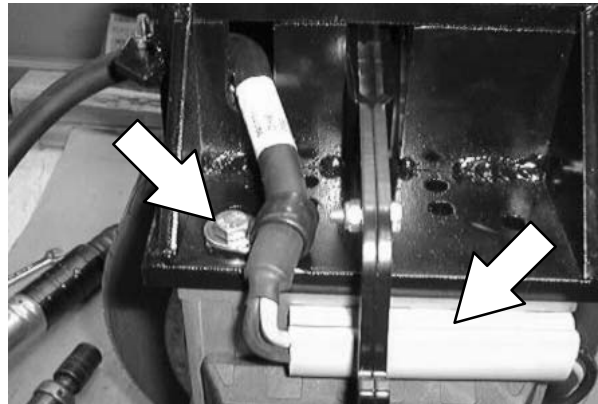

9. Go to the operators compartment and locate the clevis pin holding the brake pedal assembly to the floor plate. Remove the clevis pin and tension spring from the brake pedal.

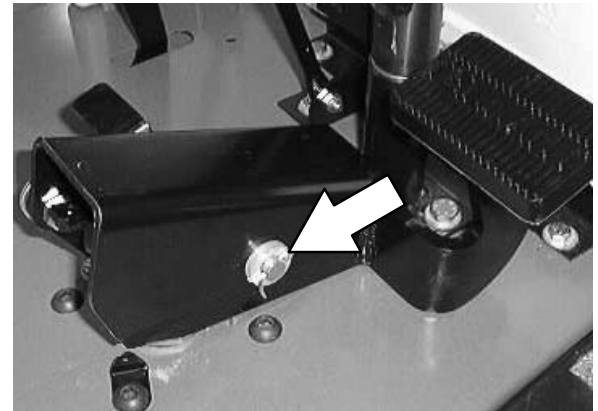

10. Pull the brake pedal up and disconnect the clevis end of the short brake rod where it attaches to the brake pedal assembly.

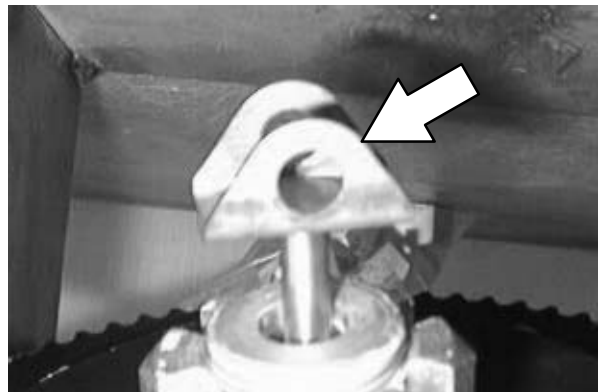

11. Support the front drive assembly with a jack or blocks. Remove the four button head screws holding the front drive assembly in the machine.

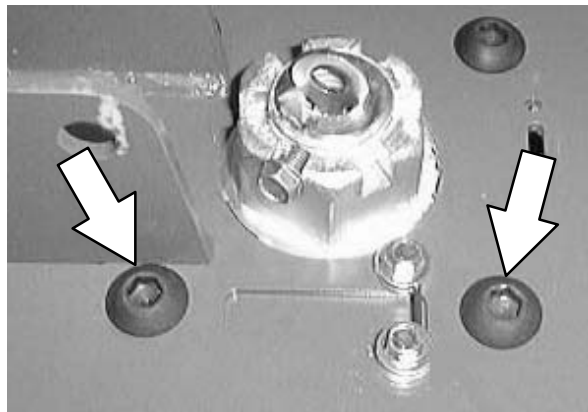

12. Lower the drive assembly down and out of the machine.

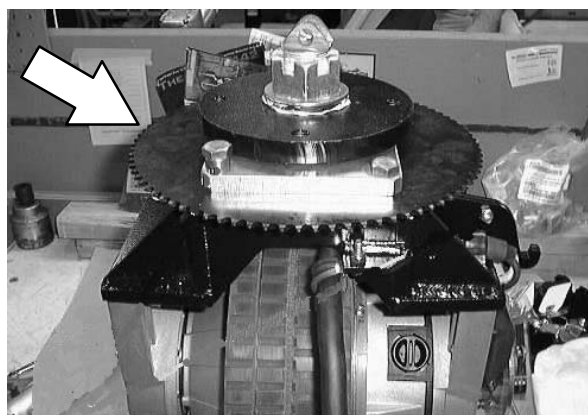

## CHASSIS

### TO INSTALL FRONT DRIVE ASSEMBLY

**FOR SAFETY: Before Leaving Or Servicing Machine; Stop On Level Surface, place blocks in front and back of the rear tires.**

1. Use a floor jack to position the drive assembly into the machine.

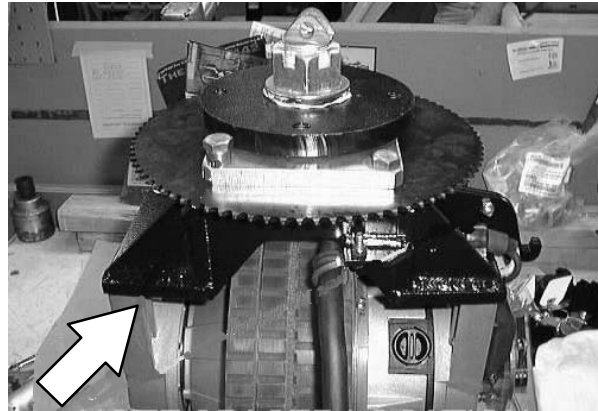

2. Line up the four threaded holes in the swivel plate weldment with the mount holes in the machine frame. Reinstall the four button head screws and tighten to 64 – 83 Nm (47 – 61 ft lb). *Make sure the brake assembly is on the right side of the machine.*

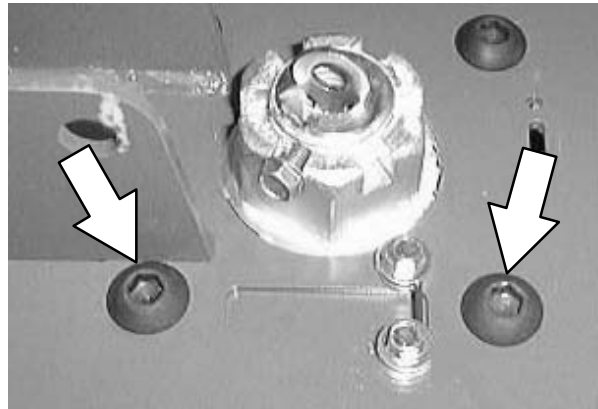

3. Reinstall the steering chain onto both steering sprockets. Reinstall the master link.

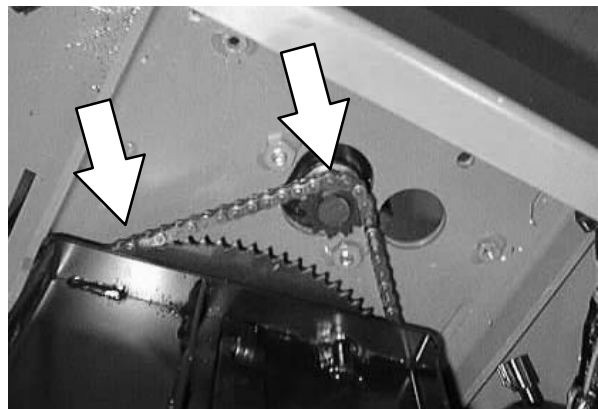



4. Go back to the operators compartment. Push the steering housing forward in the slots. This will remove any slack in the steering chain. Tighten the two hex screws to 37 – 48 Nm (26 – 34 ft lb).

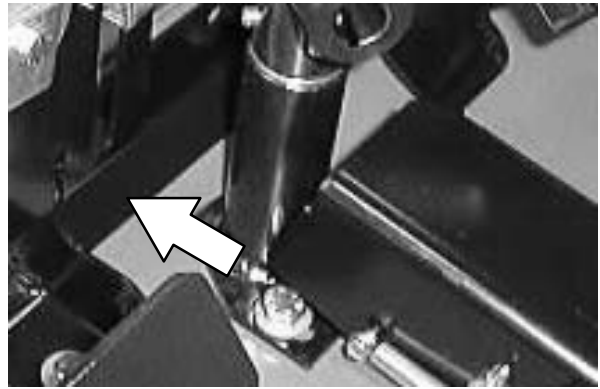

5. Reconnect the short brake rod to the brake pedal.



6. Reinstall the brake pedal and clevis pin.

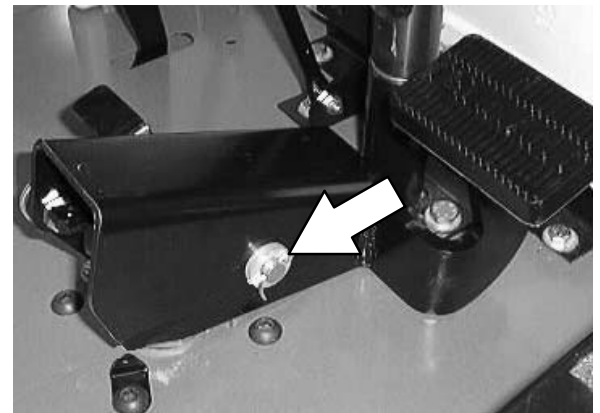

7. Route the drive motor wire onto the drive assembly.



## CHASSIS

8. Reconnect the wires to the drive motor.

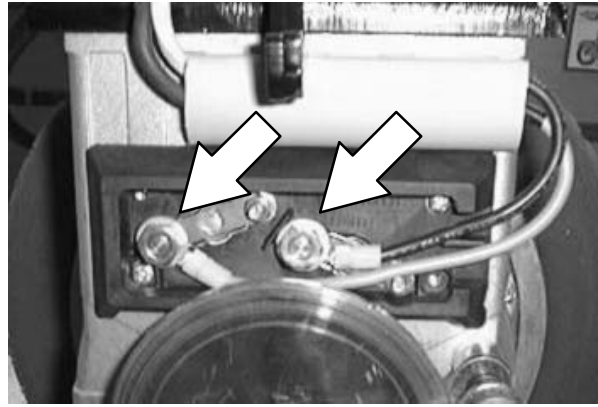

9. Reinstall the wire clamp and position the wires into the plastic sleeve.

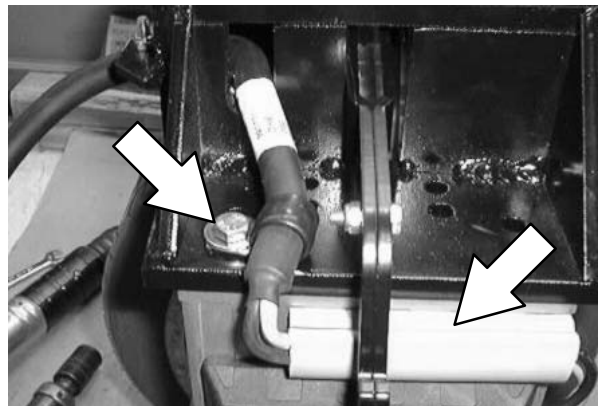

10. Reinstall the drive motor wire cover.

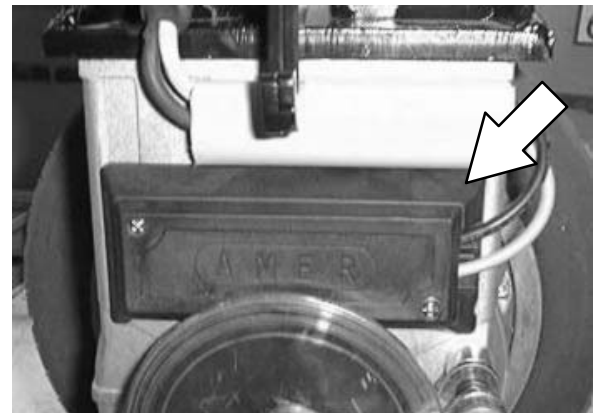

11. Reconnect the battery connector to the machine.

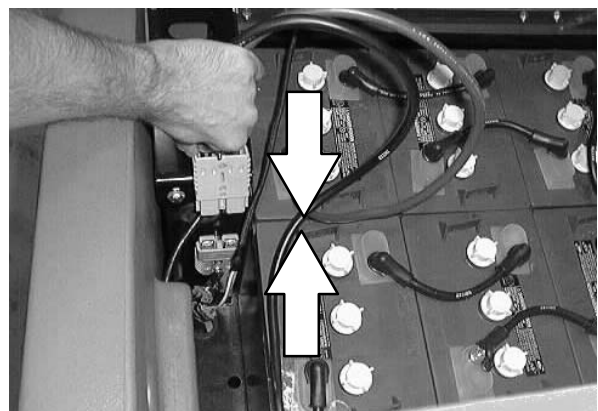

12. Close the seat support.

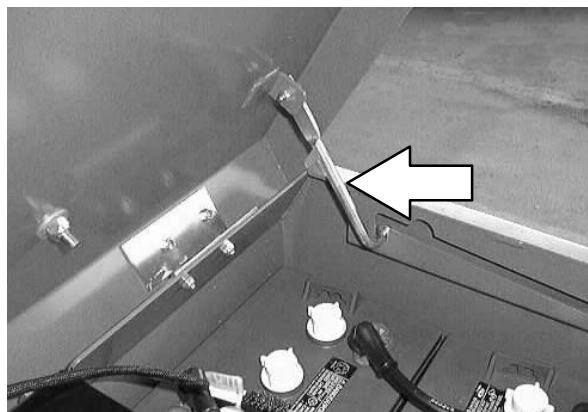

13. Lower the machine to the floor.

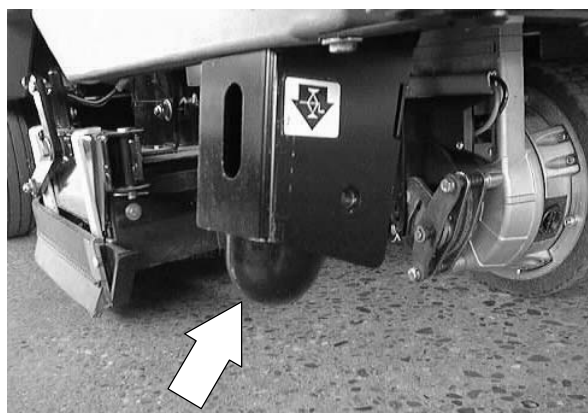

14. Operate the machine. Check the front drive for proper operation.

## CHASSIS

### TO REPLACE FRONT TIRE

**FOR SAFETY: Before Leaving Or Servicing Machine; Stop On Level Surface, place blocks in front and back of the rear tires.**

1. Remove the front drive assembly. See TO REMOVE FRONT DRIVE ASSEMBLY instructions in this section.

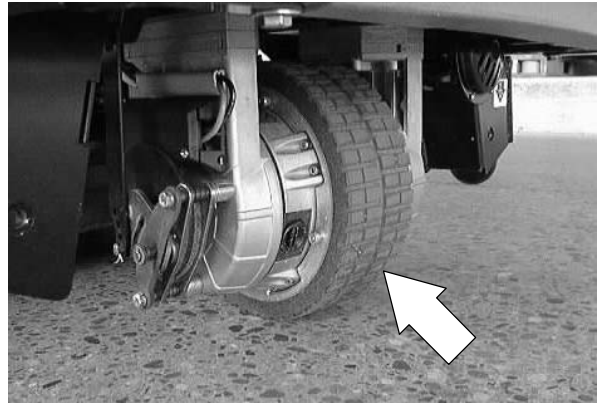

2. Remove the eight hex screws holding the steering weldment to the top of the drive assembly. Remove the steering weldment from the top of the drive assembly.

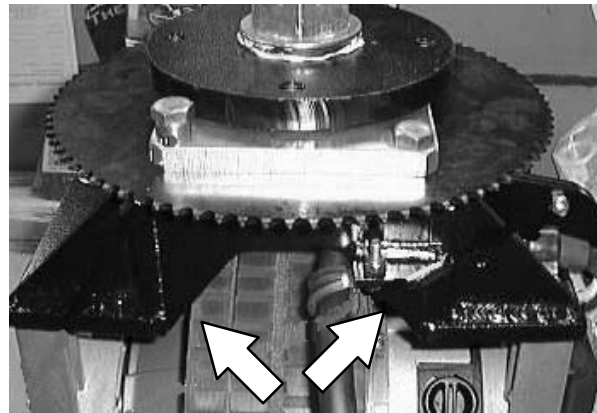

3. Position the drive assembly (*gearbox end facing down*) onto a work bench.

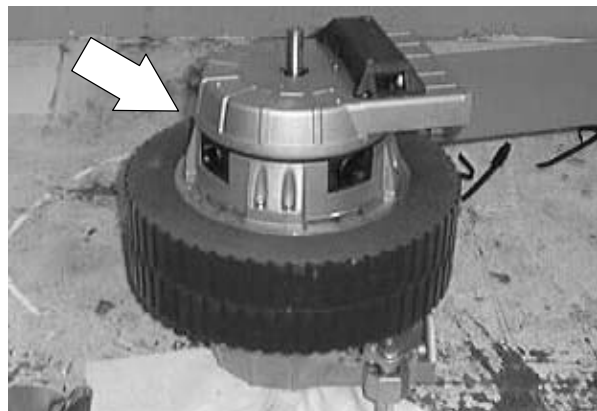

4. Remove the eight M5 cap screws holding the motor armature cap onto the drive assembly.

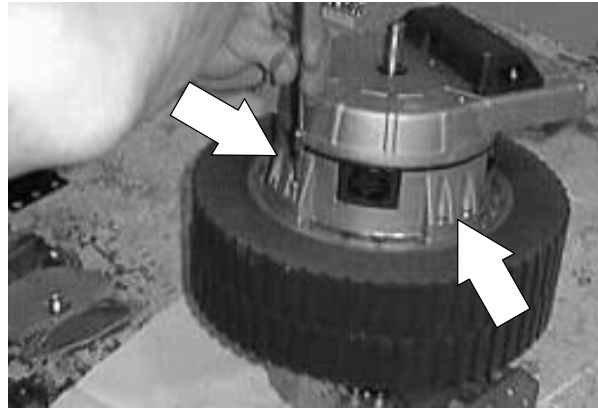

5. Mark a line on the side of the motor armature cap and the drive assembly. *This will allow proper re-assembly.*

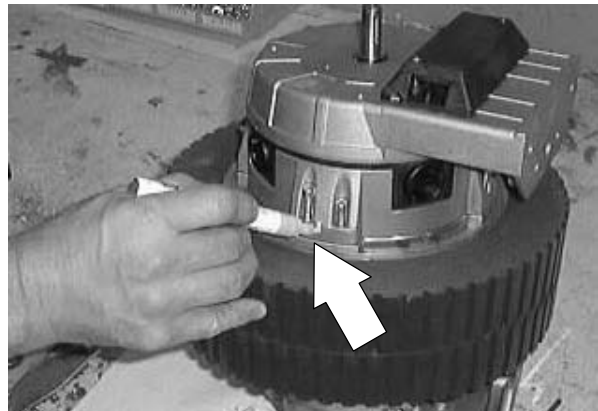

6. Remove the motor armature cap from the drive assembly. *You may have to pry the cap off with a screw driver.*

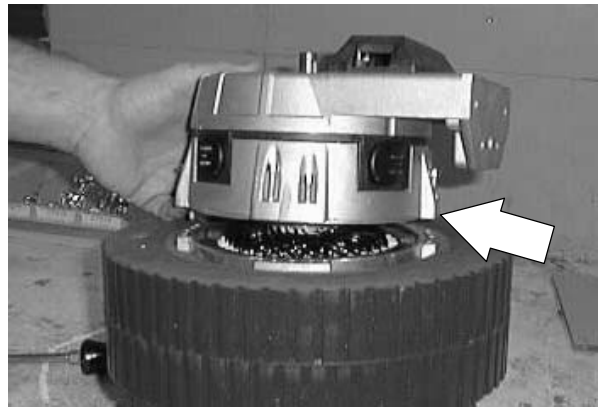

7. Set the motor armature cap to the side for now.

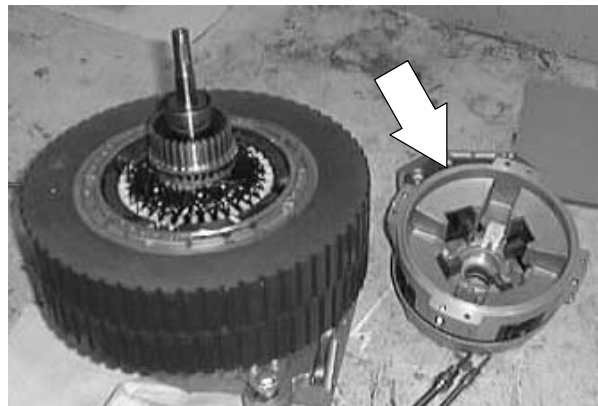

## CHASSIS

8. Make sure the wavy washer is in position inside the motor brush housing.

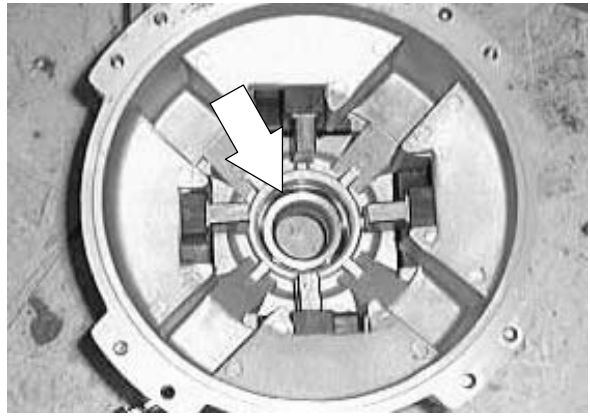

9. Remove the eight M6 cap screws holding the wheel to the gear box assembly.

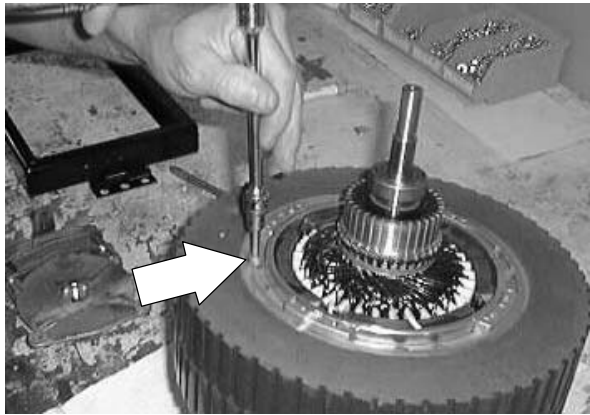

10. Lift up on the wheel.

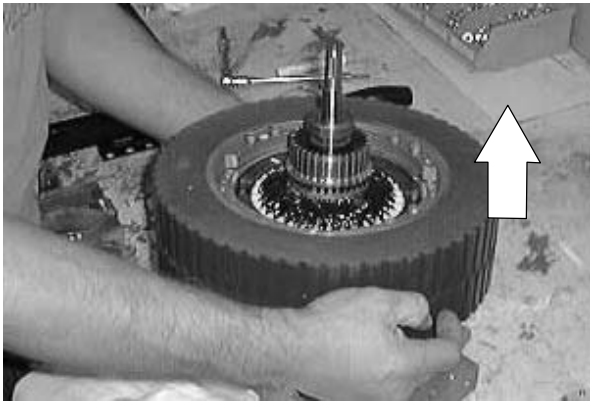

11. Remove the wheel from the gear box.

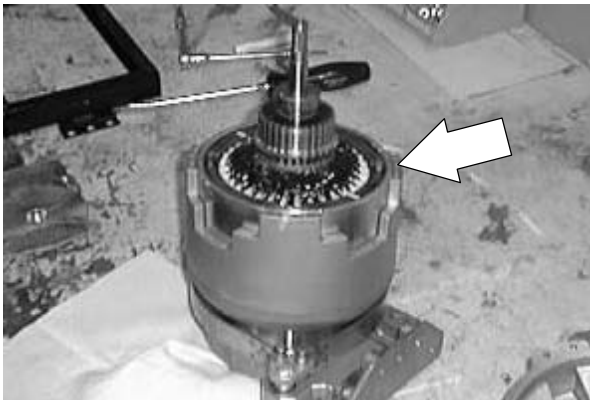

12. Position the new front tire assembly with the tabs inside the wheel rim pointing up.

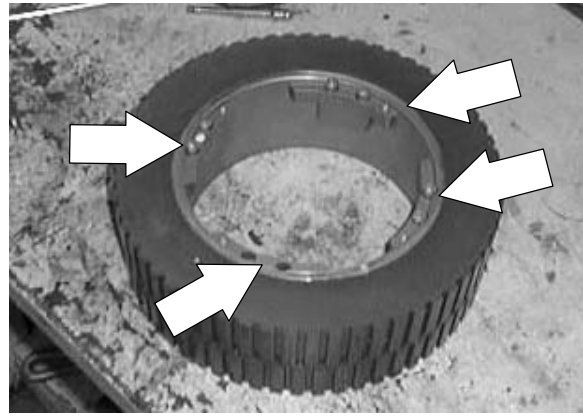

13. Place the new front tire onto the gear box.

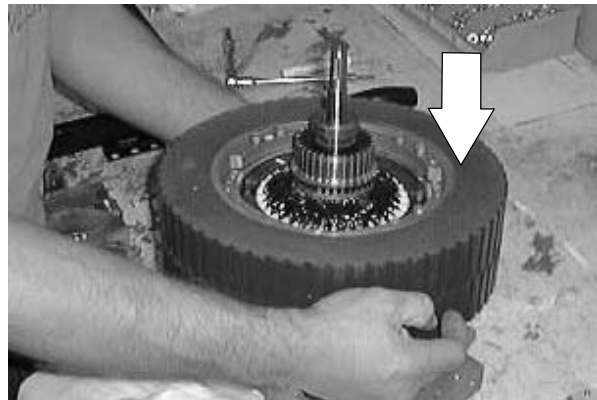

14. Reinstall the eight M6 cap screws. Tighten to 8 – 10 Nm (6 – 8 ft lb).

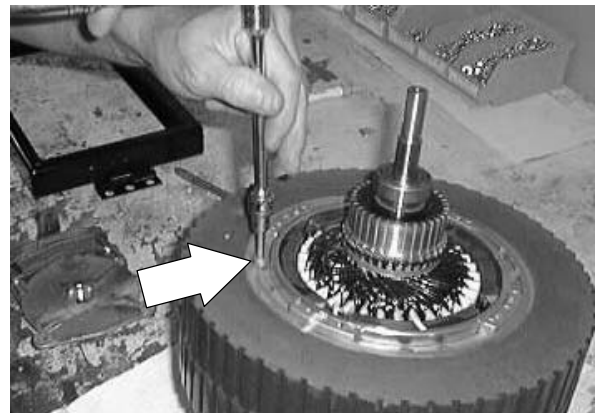

15. Before the motor end cap can be reinstalled, the four motor brushes must be removed. First, remove the black, plastic cap by turning and pulling out.



## CHASSIS

16. Remove the motor brush cover and rubber "O" ring.

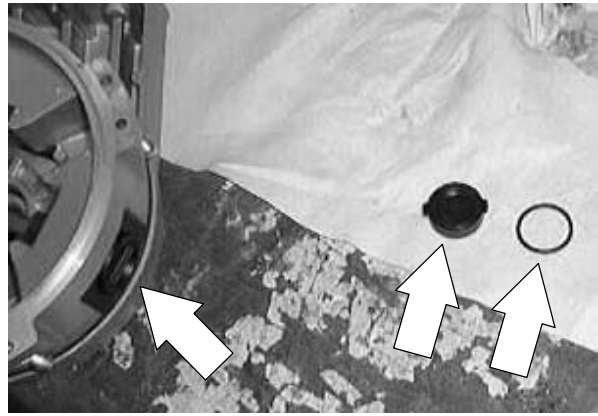

17. Remove the two screws holding the motor brush to the housing. Remove the motor brush from the housing.



18. Position the motor cap housing onto the wheel/armature assembly. *Make sure to line up the line marked on the housing.*



19. Reinstall the eight M5 cap screws. Tighten to 443 – 575Ncm (40 – 50 inch lbs).

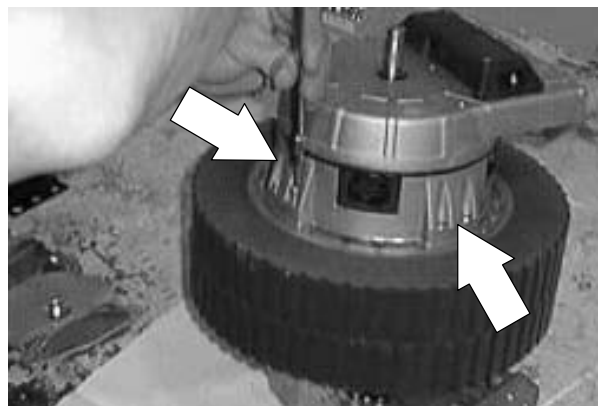



20. Reinstall the motor brushes and caps.

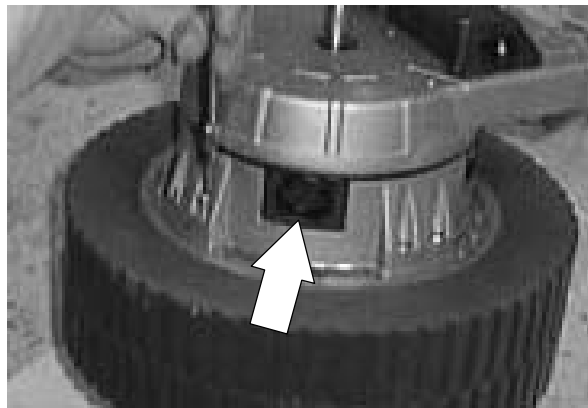

21. Reinstall the eight hex screws holding the steering weldment to the top of the drive assembly. Tighten to 18 – 24 Nm (15 – 20 ft lb).

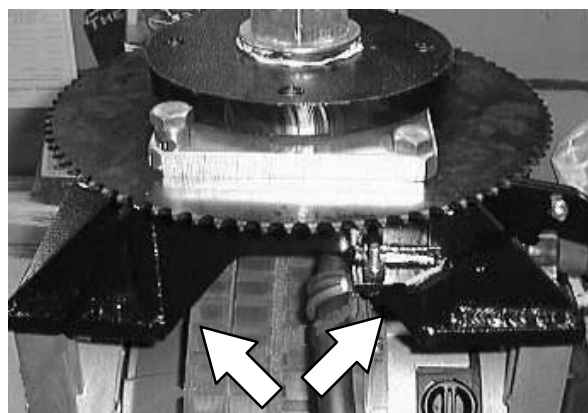

22. Reinstall the front drive assembly into the machine. See TO INSTALL FRONT DRIVE ASSEMBLY instructions in this section.

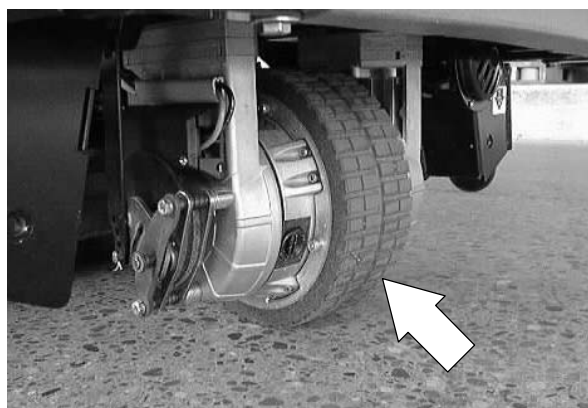

## CHASSIS

### TO ADJUST STEERING CHAIN

**FOR SAFETY: Before Leaving Or Servicing Machine; Stop On Level Surface, Set Parking Brake.**

1. Jack up the front of the machine at the jack point. Install jack stands under the machine frame.

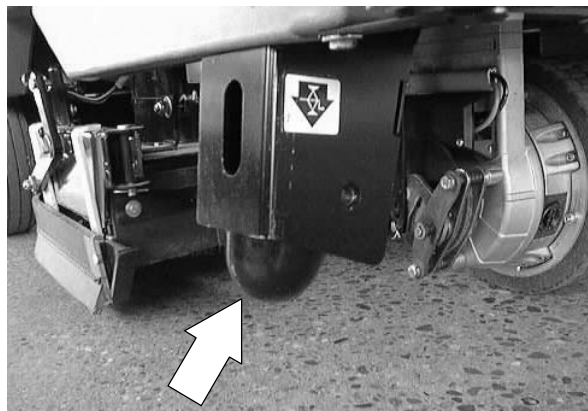

2. Go to the operators compartment and locate the two hex screws holding the steering bearing housing to the machine frame. Loosen the two screws.

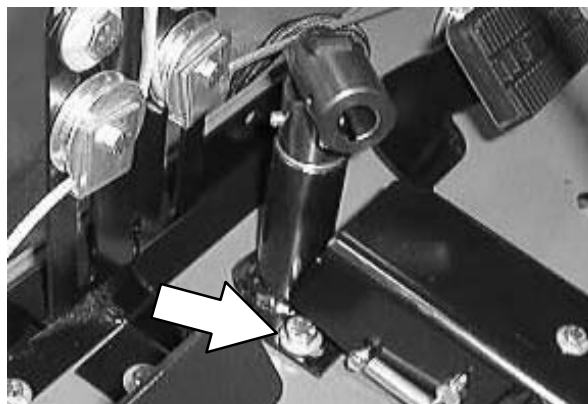

3. Turn the steering wheel all the way to the left and then to the right. Find the point in the rotation where the steering chain is the most tight.

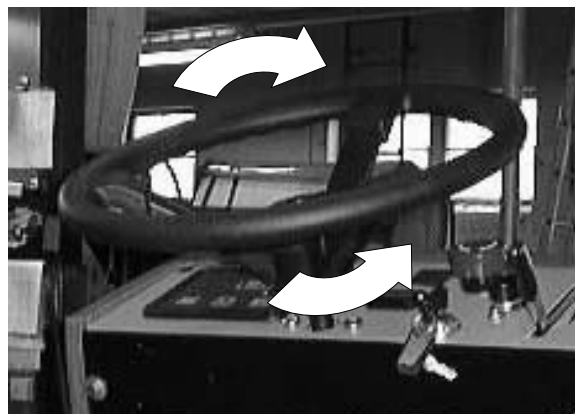

4. Push the bearing housing forward in the slots. This will remove any excess slack in the steering chain. Tighten the two hex screws to 37 – 48 Nm (26 – 34 ft lb).

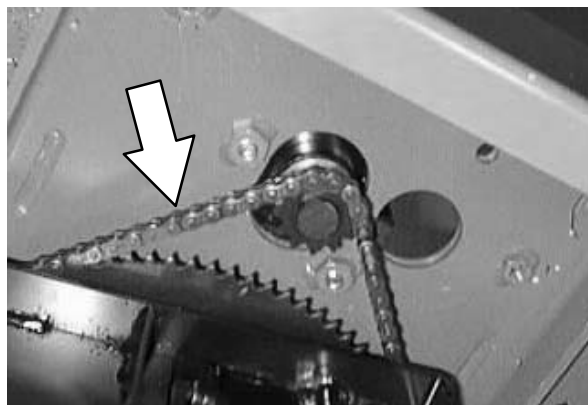

5. Remove the jack stands and lower the machine to the floor. Operate the machine and check the steering chain for proper operation.

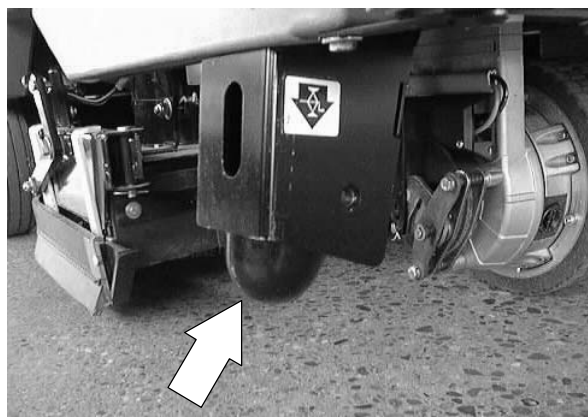

## CHASSIS

### TO REPLACE STEERING CHAIN

**FOR SAFETY: Before Leaving Or Servicing Machine; Stop On Level Surface, place blocks in front and back of the rear tires.**

1. Jack up the front of the machine at the jack point. Install jack stands under the machine frame.

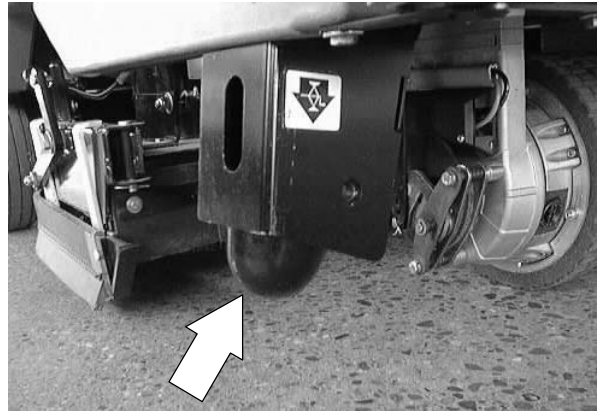

2. Turn the steering wheel all the way to the left.

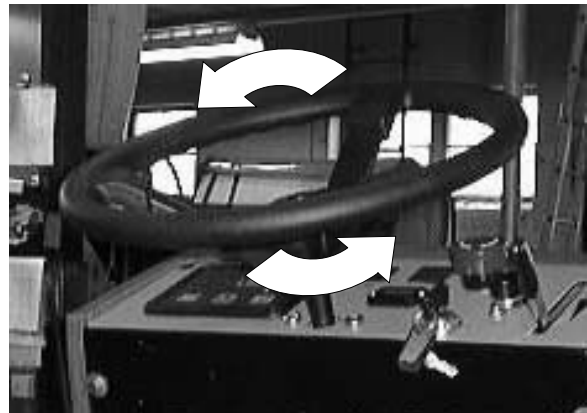

3. Go to the operators compartment and locate the two hex screws holding the steering bearing housing to the machine frame. Loosen the two screws and push the bearing housing back in the slots.

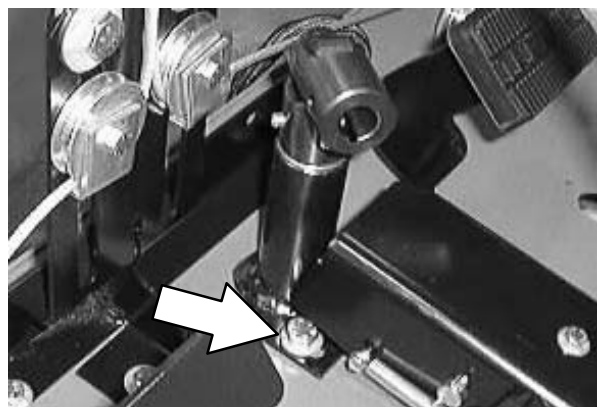

4. Go under the machine and locate the small steering chain sprocket.

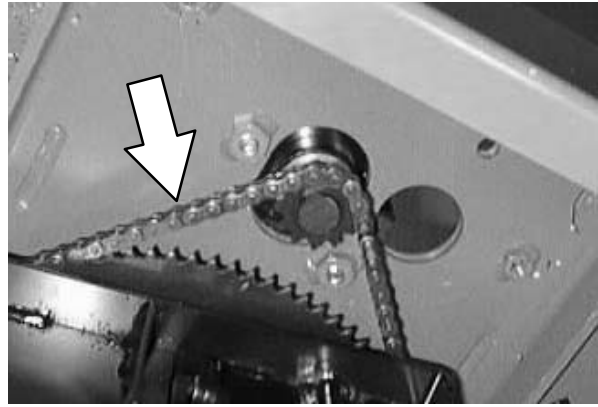

5. Locate the master link on the steering chain. Remove the master link and steering chain.

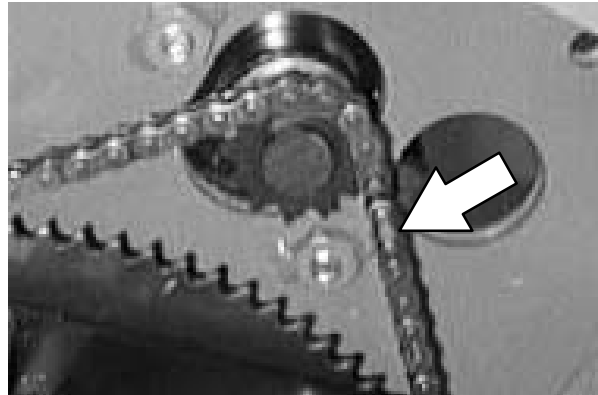

6. Position the new steering chain around both the large steering sprocket and small sprocket. Install a new master link in the new chain.

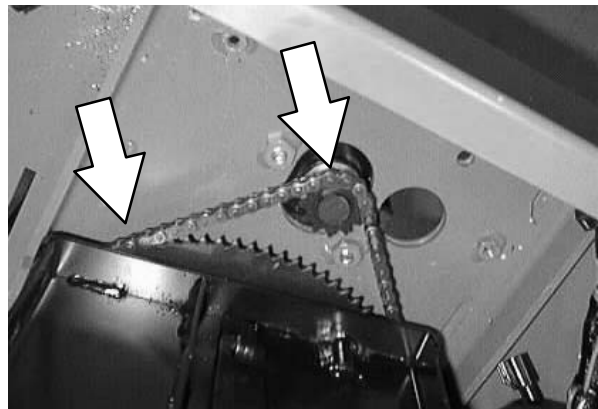

7. Turn the steering wheel all the way to the left and then to the right. Find the point in the rotation where the steering chain is the most tight.

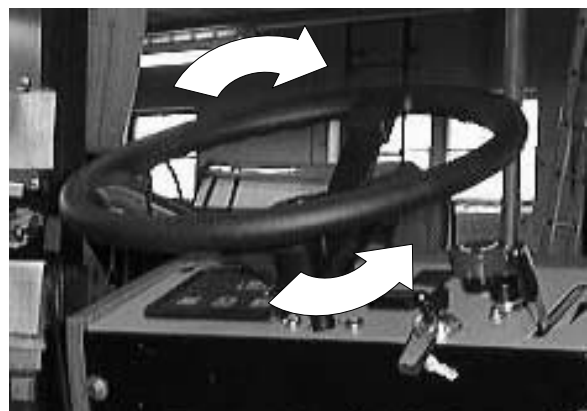

## CHASSIS

8. Push the bearing housing forward in the slots. This will remove any excess slack in the steering chain. Tighten the two hex screws to 37 – 48 Nm (26 – 34 ft lb).

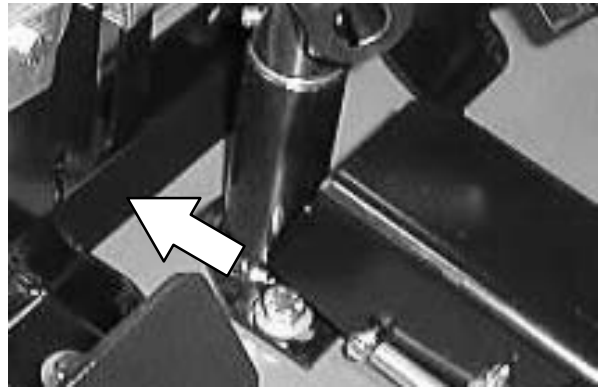

9. Remove the jack stands and lower the machine to the floor. Operate the machine and check the steering chain for proper operation.

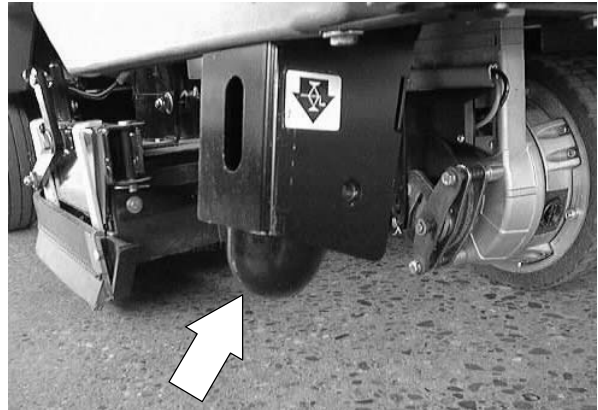

**TO REPLACE STEERING HOUSING BEARINGS**

**FOR SAFETY: Before Leaving Or Servicing Machine; Stop On Level Surface, Set Parking Brake.**

1. Jack up the front of the machine at the jack point. Install jack stands under the machine frame.

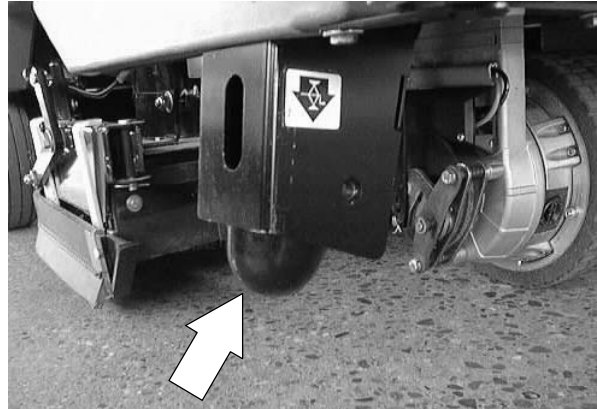

2. Turn the steering wheel all the way to the left.

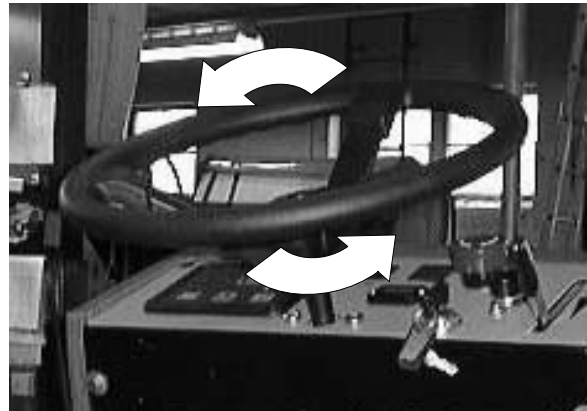

3. Go to the operators compartment and locate the steering U-joint. Loosen the two set screws on the top of the steering U-joint.

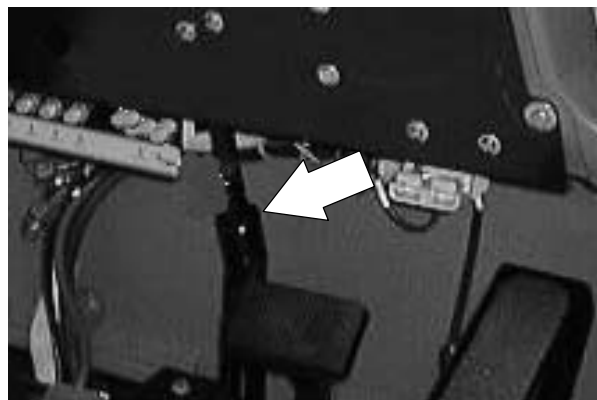

## CHASSIS

4. Pull the steering wheel and long steering shaft up and out of the top of the steering U-joint.

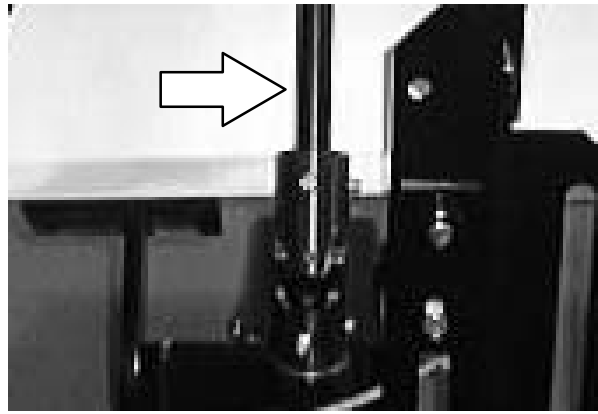

5. Remove the two hex screws holding the steering bearing housing to the machine frame. Push the bearing housing back in the slots.

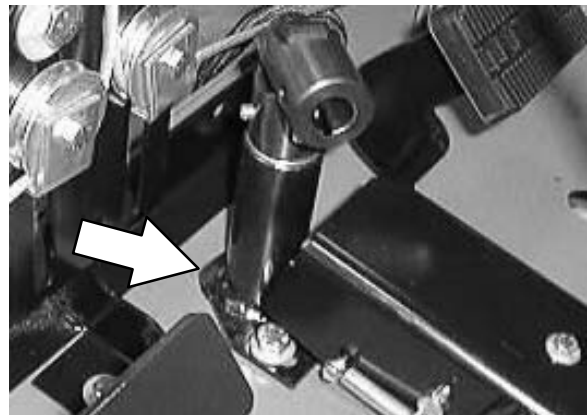

6. Go under the machine and locate the small steering chain sprocket.

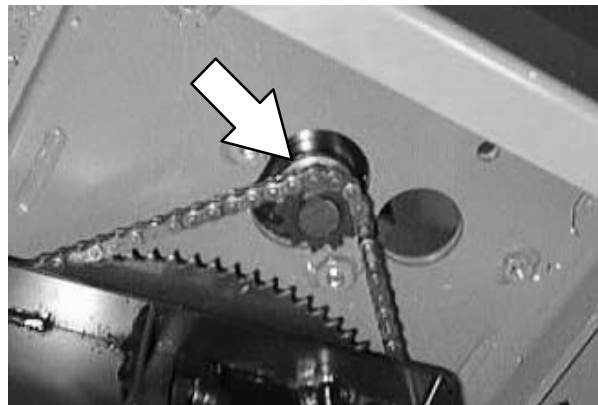

7. Locate the master link on the steering chain. Remove the master link and steering chain from the small steering sprocket.

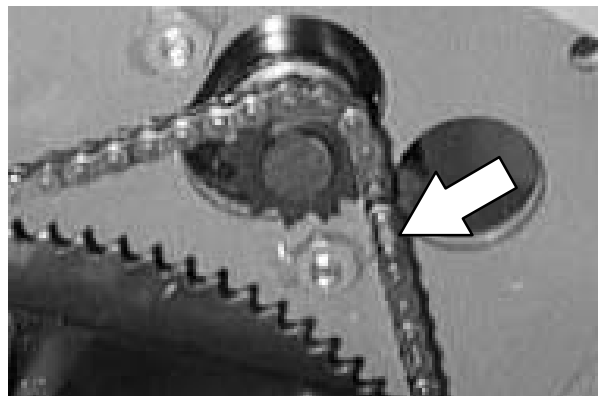



8. Remove the steering housing from the machine.

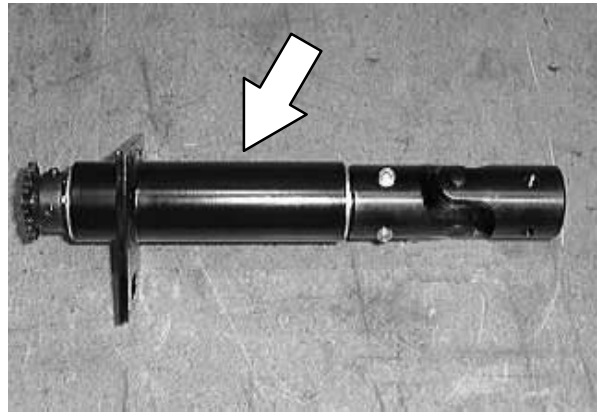

9. Loosen the two set screws holding the U-joint to the top of the short steering shaft. Remove and retain the U-joint and square key.

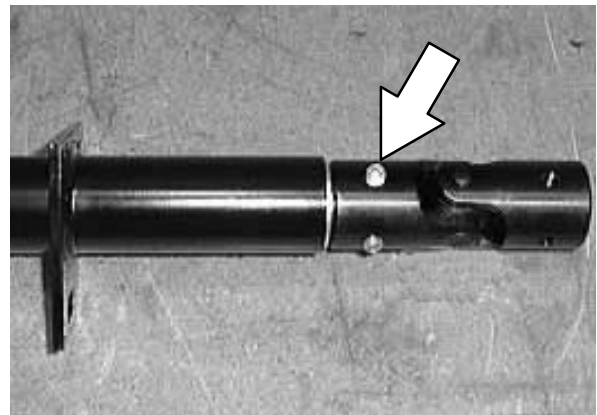

10. Loosen the set screw holding the small steering sprocket to the bottom of the short steering shaft. Remove and retain small sprocket and woodruff key.

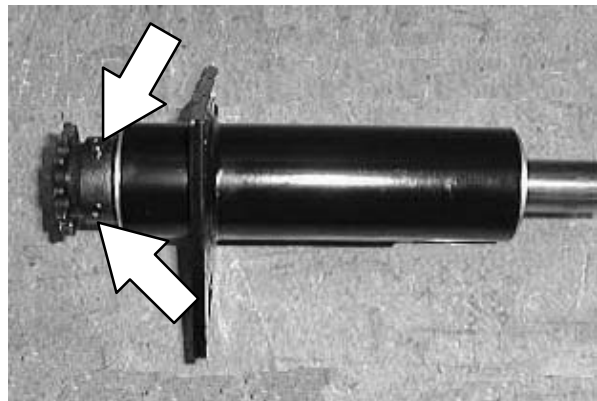

11. Use an arbor press to press the short steering shaft and two bearings out of the housing. Discard the bearings. Retain the short shaft. *Note the orientation of the shaft in the housing.*

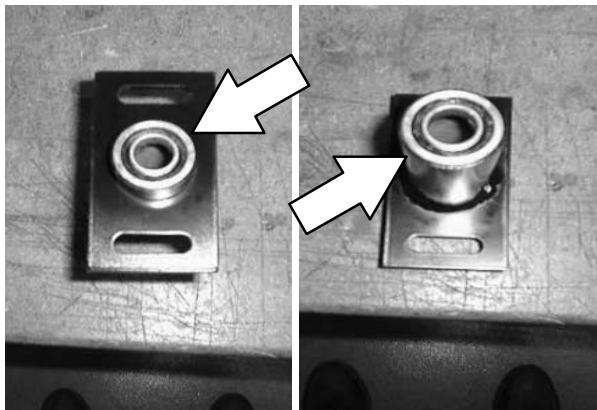

## CHASSIS

12. Use the arbor press to install the new bearings into the steering housing.

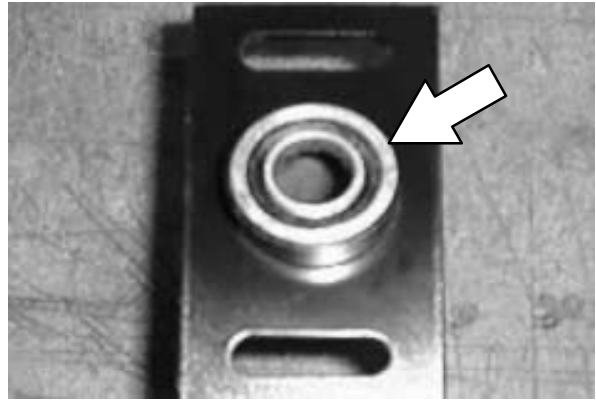

13. Use the arbor press to install the short steering shaft into the new bearings.

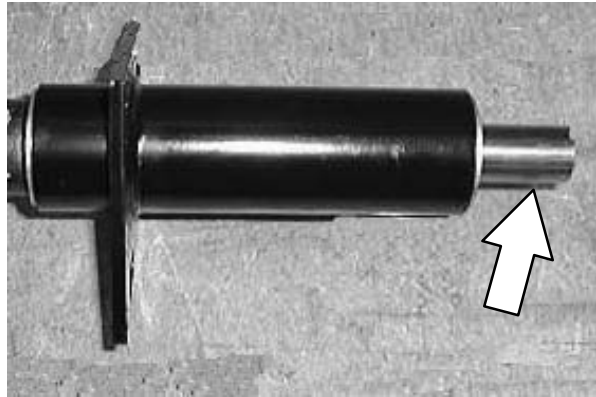

14. Reinstall the small steering sprocket and woodruff key on the bottom of the steering housing. Tighten the set screws tight.

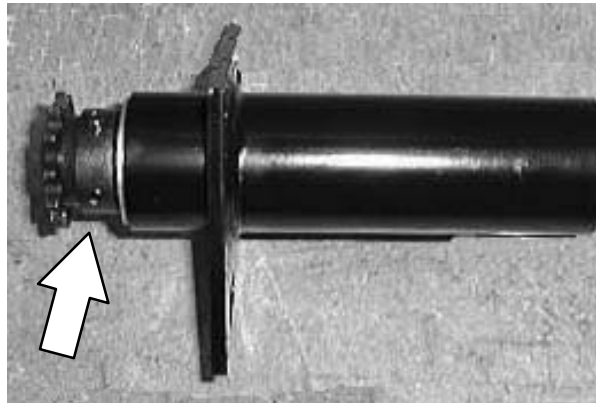

15. Reinstall the U-joint and square key on the top of the steering housing. Tighten the set screws tight.

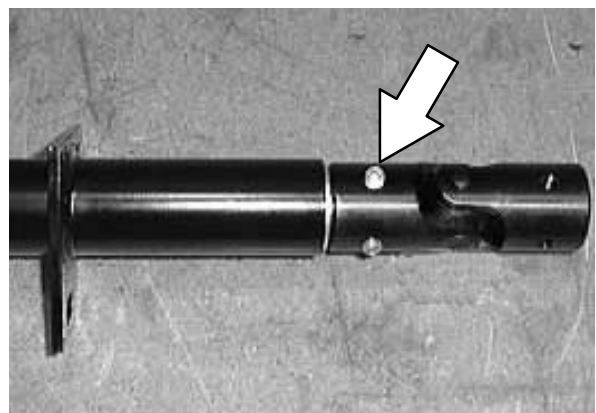

16. Reinstall the steering housing in the machine. Reinstall the two hex screws. Leave loose for now.

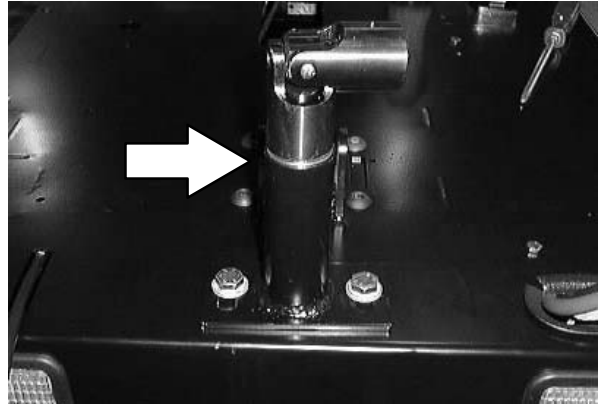

17. Position the long steering shaft and steering wheel into the top of the steering U-joint. Tighten the set screws tight.

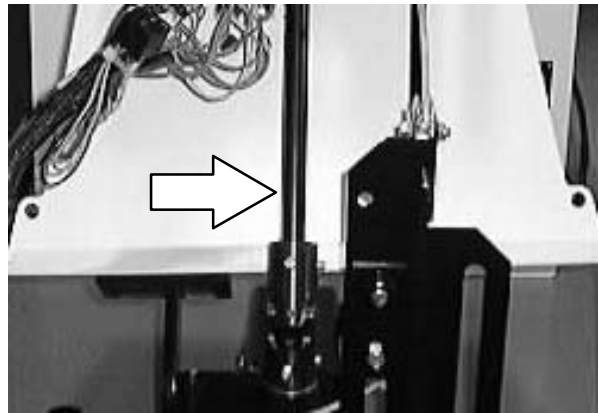

18. Go under the machine and reinstall the steering chain around the small steering sprocket. Reinstall the master link.

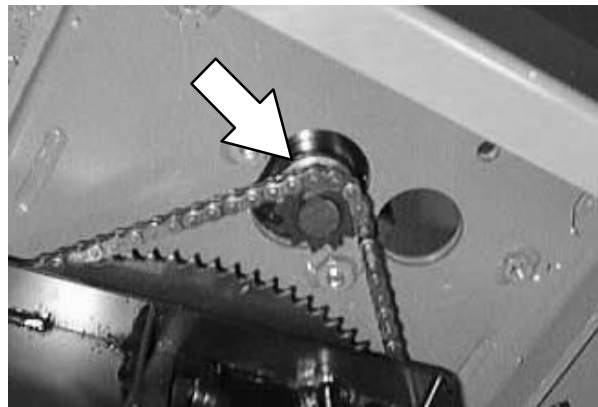

19. Turn the steering wheel all the way to the left and then to the right. Find the point in the rotation where the steering chain is the most tight.

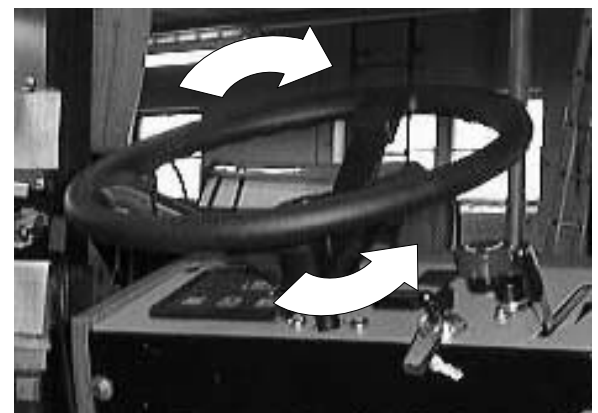

## CHASSIS

20. Push the bearing housing forward in the slots. This will remove any excess slack in the steering chain. Tighten the two hex screws to 37 – 48 Nm (26 – 34 ft lb).

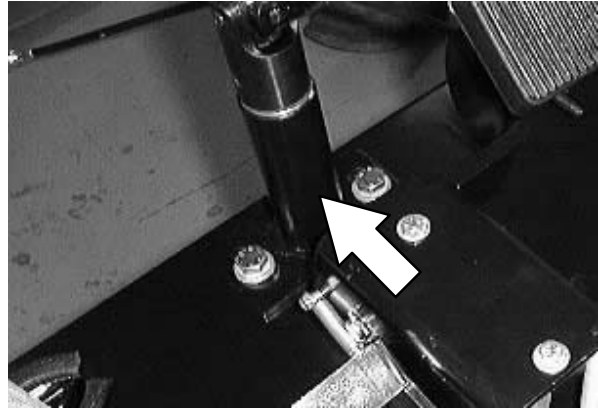

21. Remove the jack stands and lower the machine to the floor. Operate the machine and check the steering chain for proper operation.

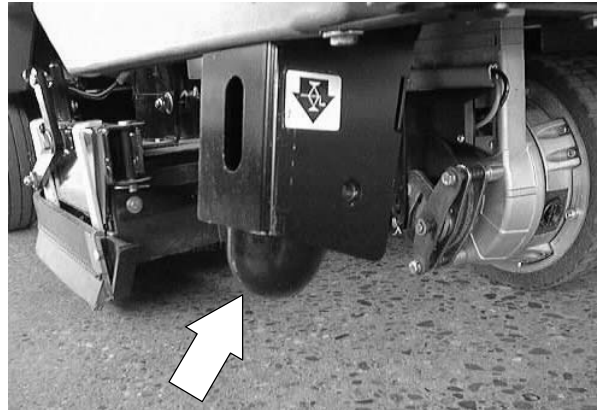

**TO REPLACE STEERING U-JOINT**

**FOR SAFETY: Before Leaving Or Servicing Machine; Stop On Level Surface, Set Parking Brake.**

1. Jack up the front of the machine at the jack point. Install jack stands under the machine frame.

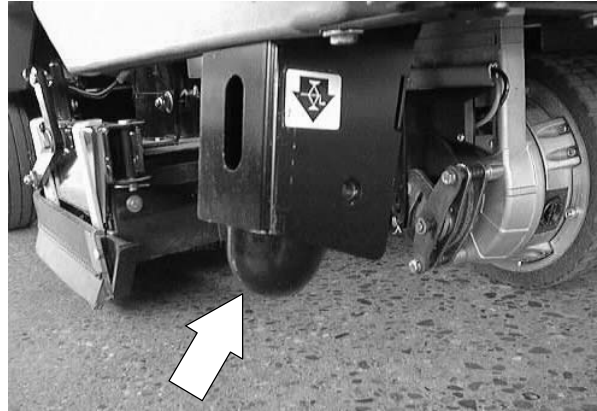

2. Go to the operators compartment and locate the steering U-joint. Loosen the two set screws on the top of the steering U-joint.

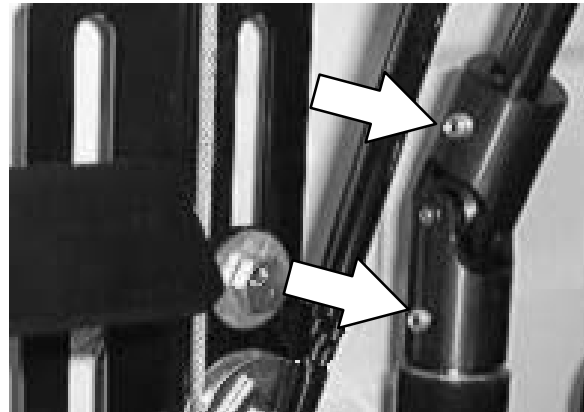

3. Pull the steering wheel and long steering shaft up and out of the top of the steering U-joint.

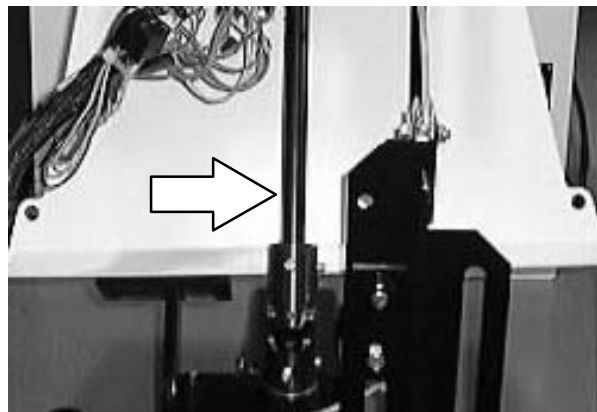

## CHASSIS

4. Loosen the two set screws holding the U-joint to the top of the short steering shaft. Remove and discard the U-joint and square key.

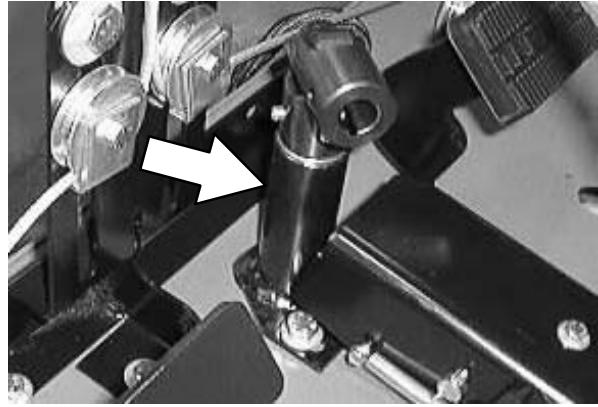

5. Install the new U-joint and square key on the top of the steering housing. Tighten the set screws tight.

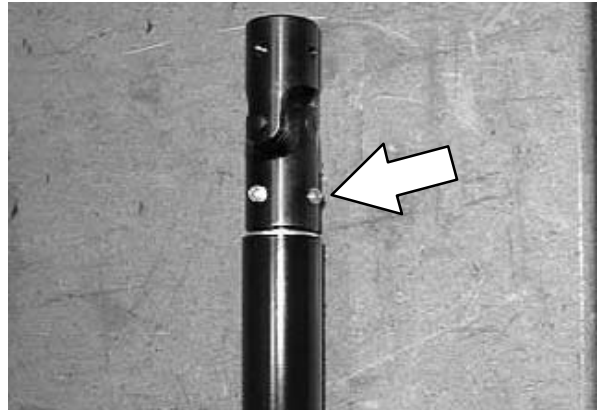

6. Position the long steering shaft and steering wheel into the top of the steering U-joint. Tighten the set screws tight.

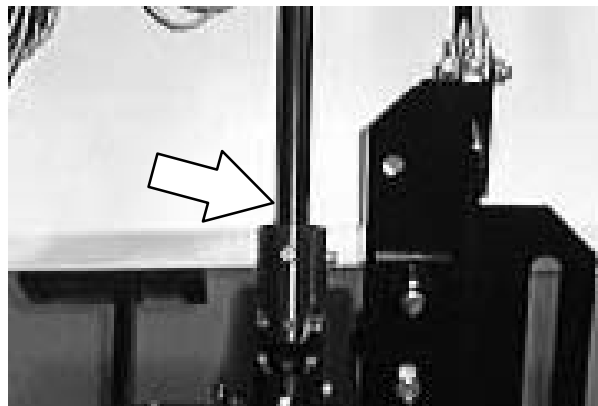

7. Operate the machine and check the steering U-joint for proper operation.

**TO REPLACE SMALL STEERING SPROCKET**

**FOR SAFETY: Before Leaving Or Servicing Machine; Stop On Level Surface, Set Parking Brake.**

1. Jack up the front of the machine at the jack point. Install jack stands under the machine frame.

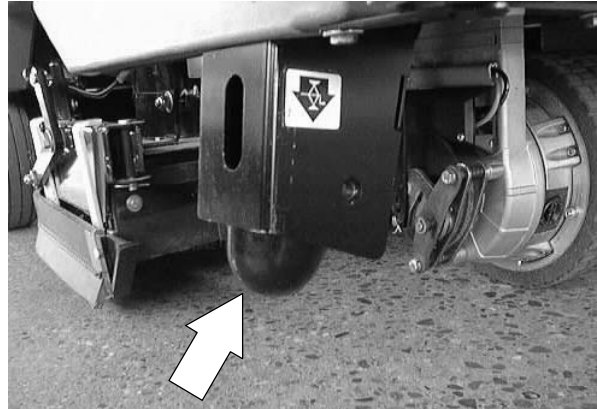

2. Turn the steering wheel all the way to the left.

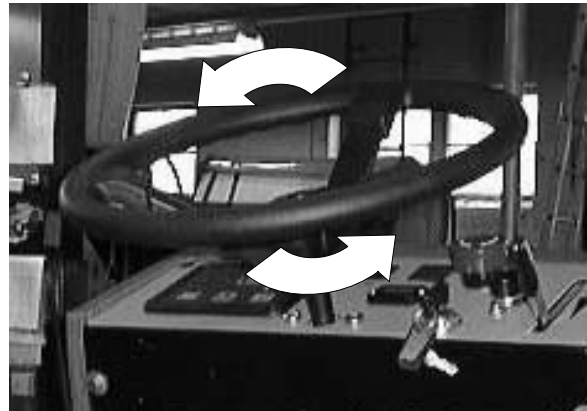

3. Go to the operators compartment and locate the two hex screws holding the steering bearing housing to the machine frame. Loosen the two screws and push the bearing housing back in the slots. *This will loosen the steering chain.*

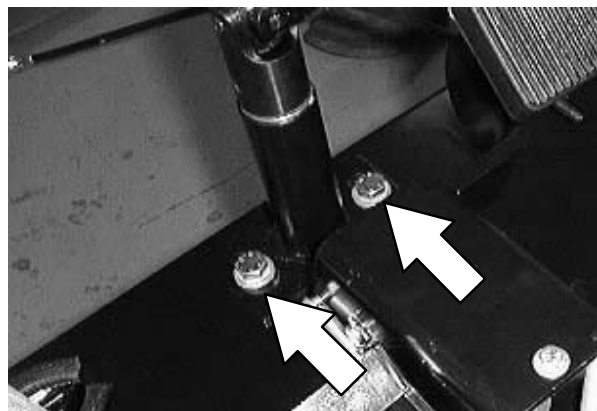

## CHASSIS

4. Go under the machine and locate the small steering chain sprocket.

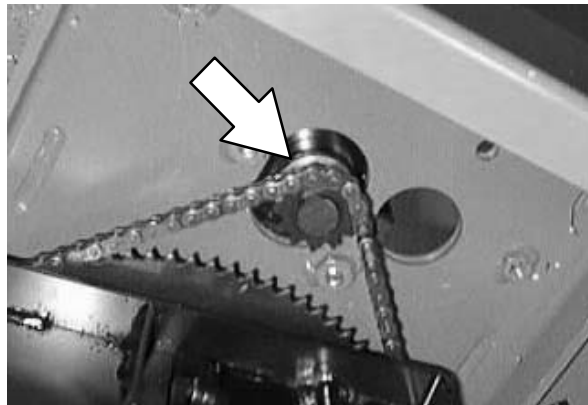

5. Locate the master link on the steering chain. Remove the master link from the steering chain.

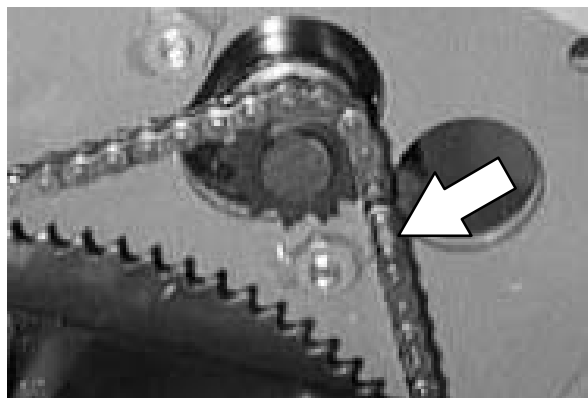

6. Loosen the set screw holding the small steering sprocket to the bottom of the short steering shaft. Remove and discard the woodruff key. Retain the woodruff key.

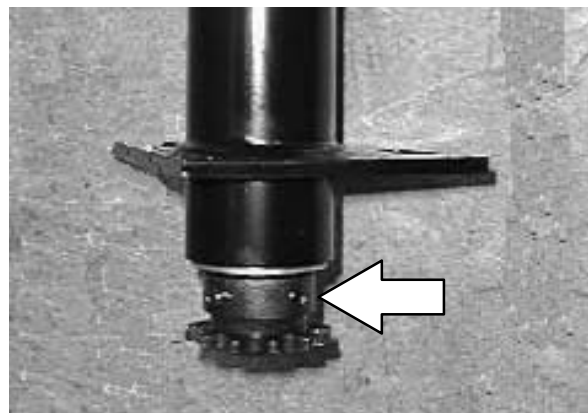

7. Install the new small sprocket and woodruff key onto the steering shaft. The teeth of the new sprocket face down. Position the sprocket in the same location as the old one. Tighten the two set screws tight.

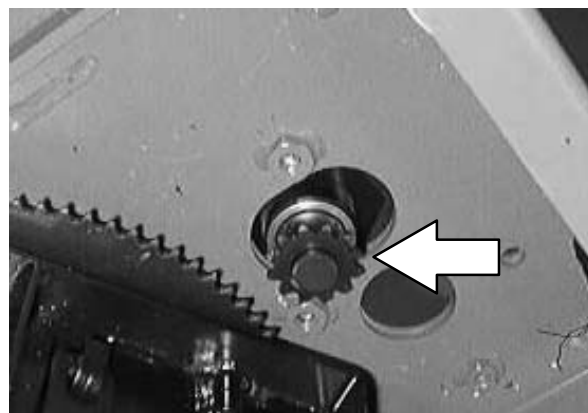



- Place the steering chain around the new sprocket. Reinstall the master link.

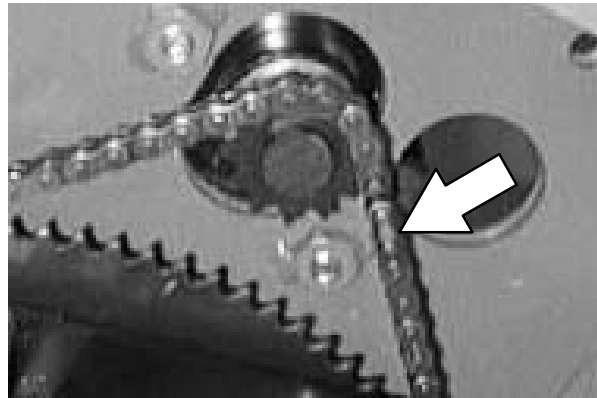

- Turn the steering wheel all the way to the left and then to the right. Find the point in the rotation where the steering chain is the most tight.

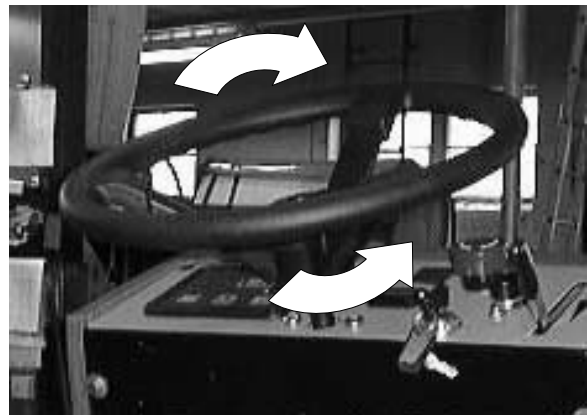

- Push the bearing housing forward in the slots. This will remove any excess slack in the steering chain. Tighten the two hex screws to 37 – 48 Nm (26 – 34 ft lb).

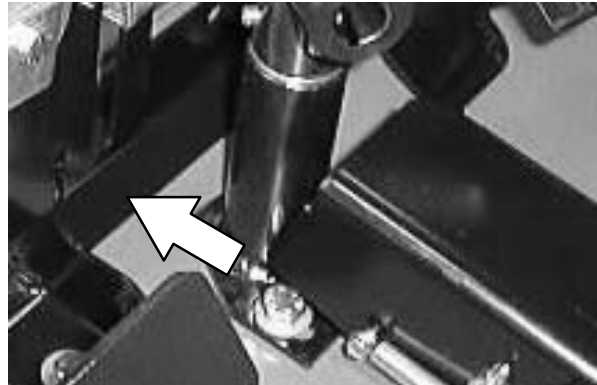

- Remove the jack stands and lower the machine to the floor. Operate the machine and check the steering for proper operation.

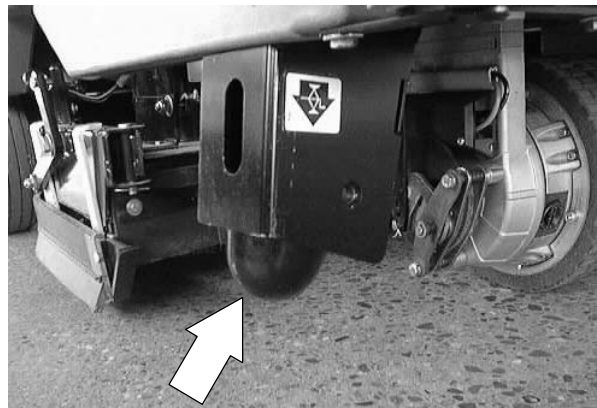

## CHASSIS

### TO REPLACE LARGE STEERING SPROCKET

**FOR SAFETY: Before Leaving Or Servicing Machine; Stop On Level Surface, place blocks in front and back of the rear tires.**

1. Jack up the front of the machine at the jack point. Install jack stands under the machine frame.

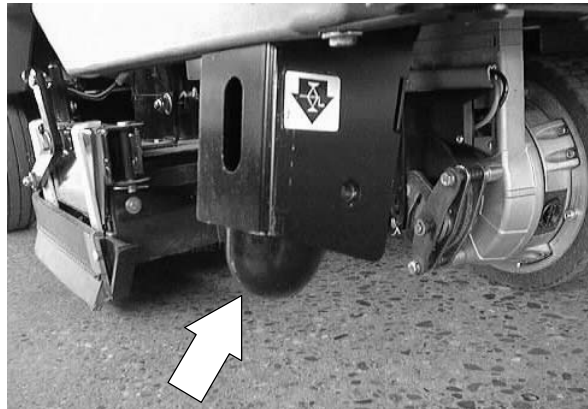

2. Turn the steering wheel all the way to the left.

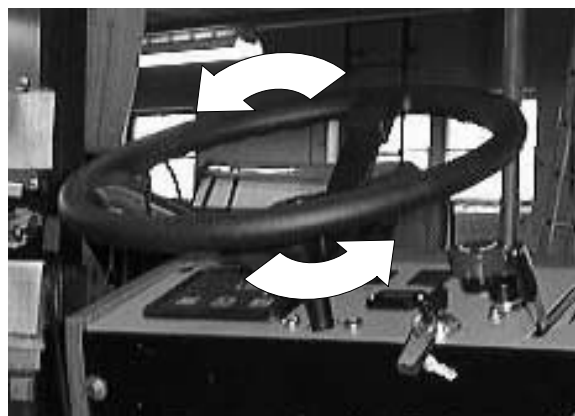

3. Go to the operators compartment and locate the two hex screws holding the steering bearing housing to the machine frame. Loosen the two screws and push the bearing housing back in the slots. *This will loosen the steering chain.*

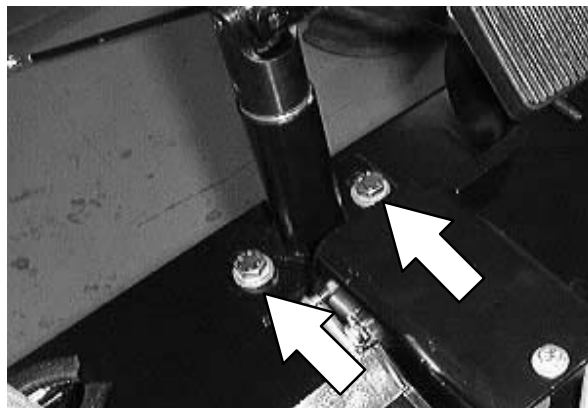

4. Locate the master link on the steering chain. Remove the master link from the steering chain. Remove the steering chain from the machine.

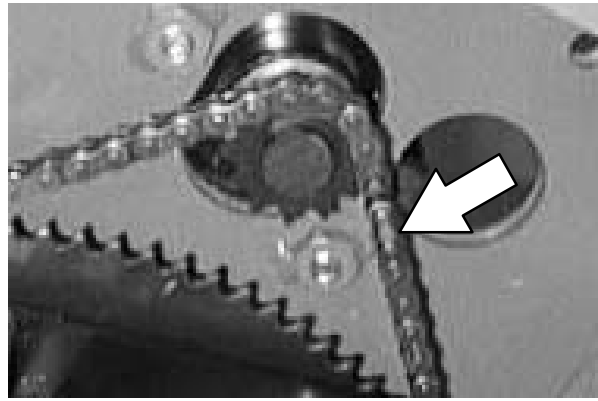

5. Remove the front drive assembly. See TO REMOVE FRONT DRIVE ASSEMBLY instructions in this section.

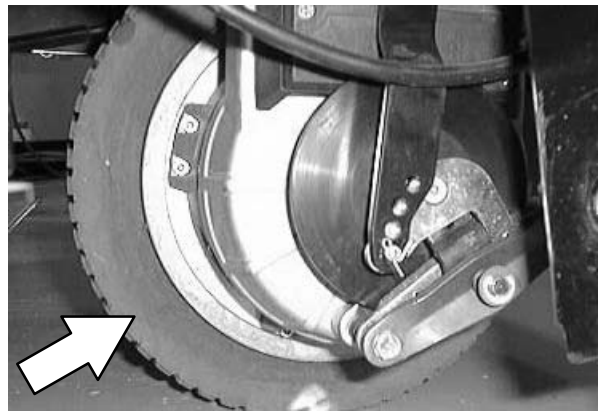

6. Remove the four hex screws holding the front drive pivot assembly to the upper drive casting. *Note the location of the spacers.*

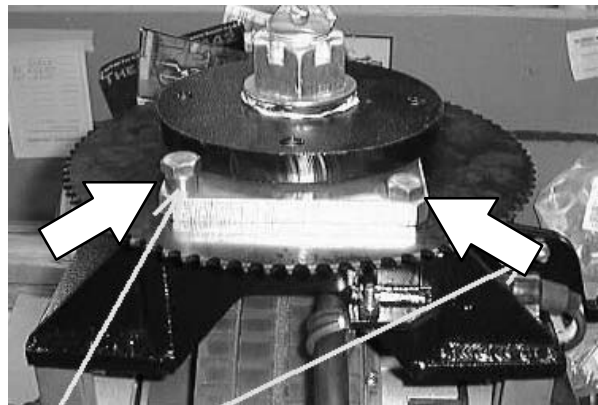

7. Remove the pivot assembly and large sprocket from the upper casting.

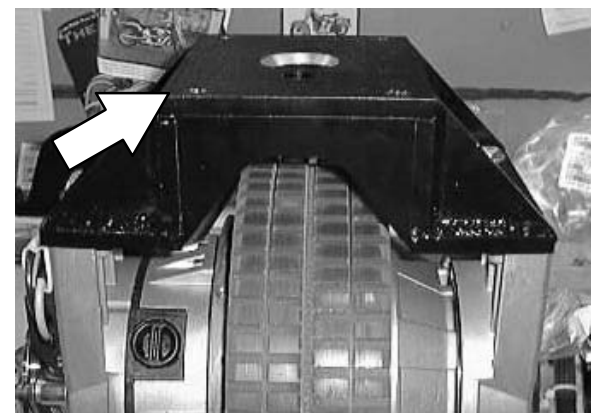

## CHASSIS

8. Position the new large steering sprocket onto the upper casting.

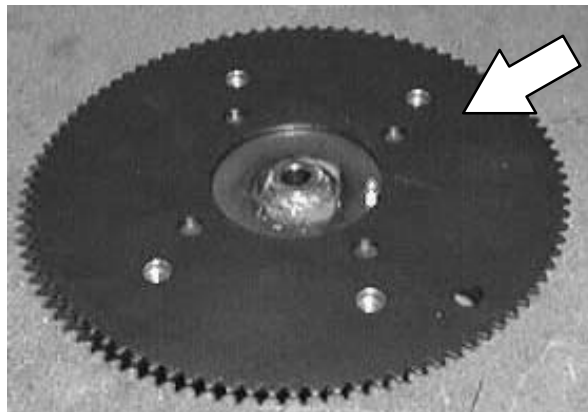

9. Position the front drive pivot assembly onto the new large sprocket. Install the four hex screws and one spacer. Use blue loctite 242 on the threads. Tighten to 37 – 48 Nm (26 – 34 ft lb).

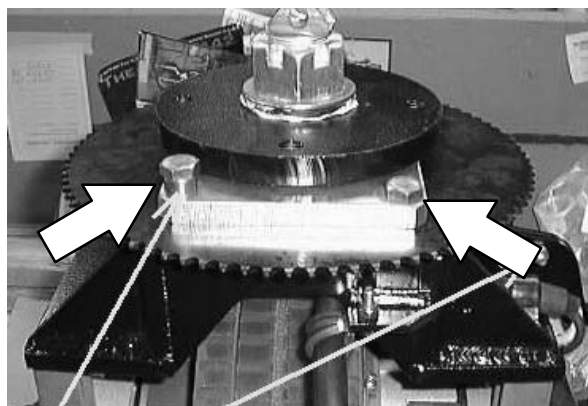

10. Reinstall the front drive assembly. See TO INSTALL FRONT DRIVE ASSEMBLY instructions in this section.

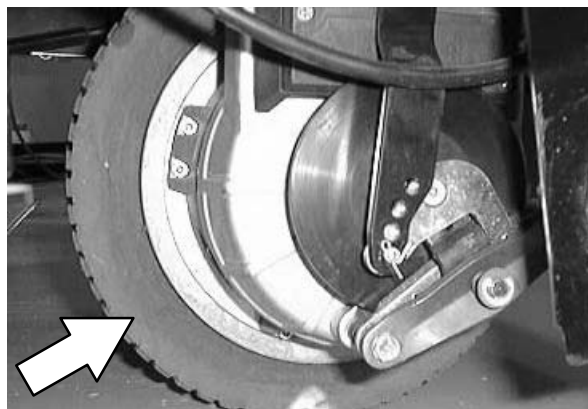

11. Reinstall the steering chain onto both steering sprockets. Reinstall the master link.

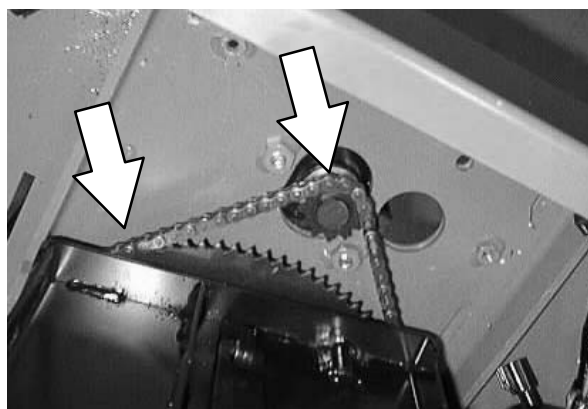

- Turn the steering wheel all the way to the left and then to the right. Find the point in the rotation where the steering chain is the most tight.

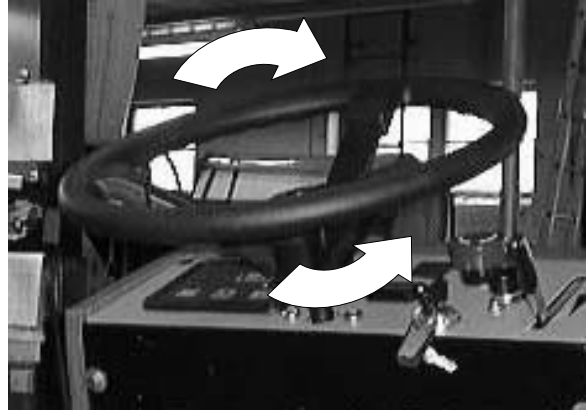

- Push the bearing housing forward in the slots. This will remove any excess slack in the steering chain. Tighten the two hex screws to 37 – 48 Nm (26 – 34 ft lb).

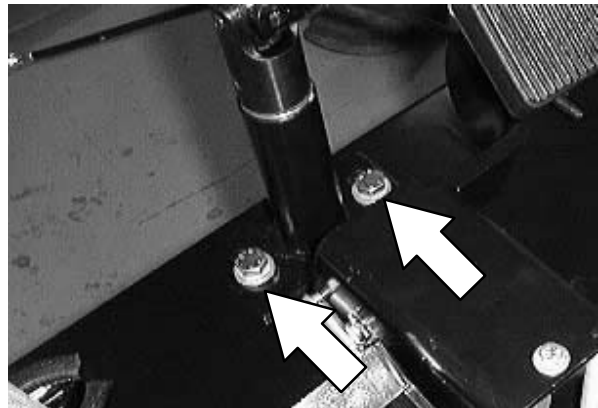

- Remove the jack stands and lower the machine to the floor. Operate the machine and check the steering for proper operation.

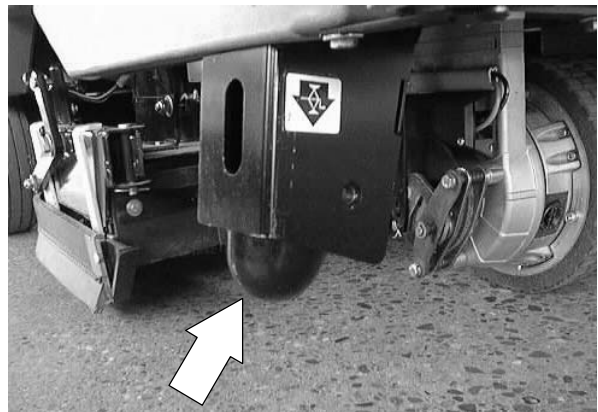

## CHASSIS

### TO REPLACE FRONT WHEEL PIVOT NEEDLE BEARING/THRUST WASHERS

**FOR SAFETY: Before Leaving Or Servicing Machine; Stop On Level Surface, place blocks in front and back of the rear tires.**

1. Jack up the front of the machine at the jack point. Install jack stands under the machine frame.

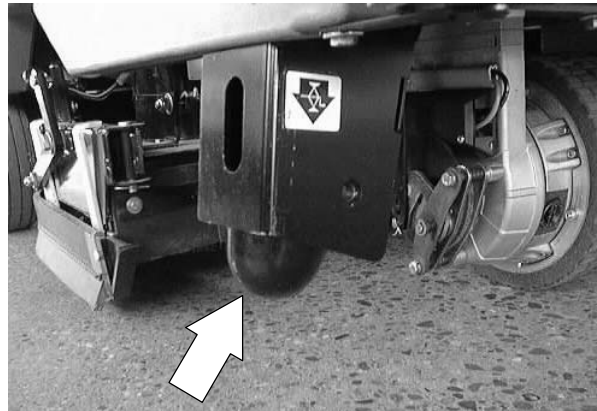

2. Turn the steering wheel all the way to the left.

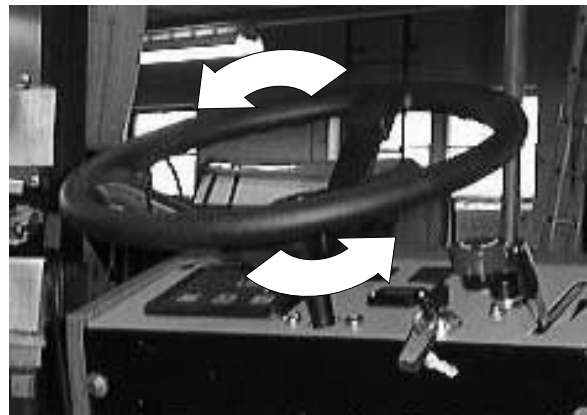

3. Go to the operators compartment and locate the two hex screws holding the steering bearing housing to the machine frame. Loosen the two screws and push the bearing housing back in the slots. *This will loosen the steering chain.*

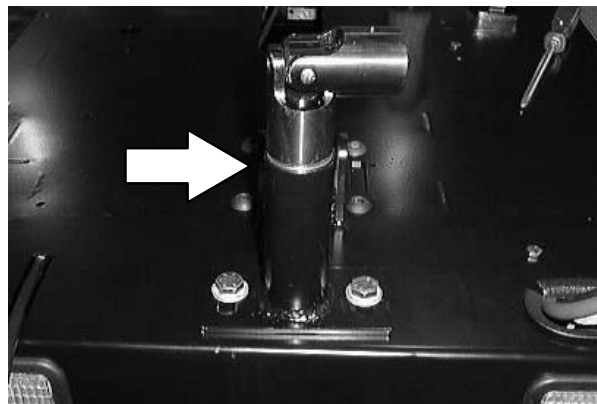

4. Locate the master link on the steering chain. Remove the master link from the steering chain. Remove the steering chain from the machine.

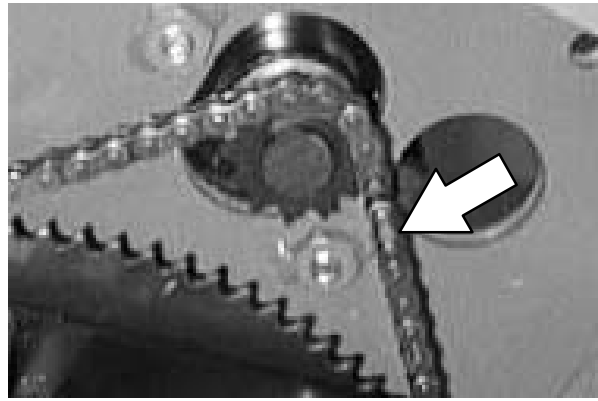

5. Remove the front drive assembly. See TO REMOVE FRONT DRIVE ASSEMBLY instructions in this section.

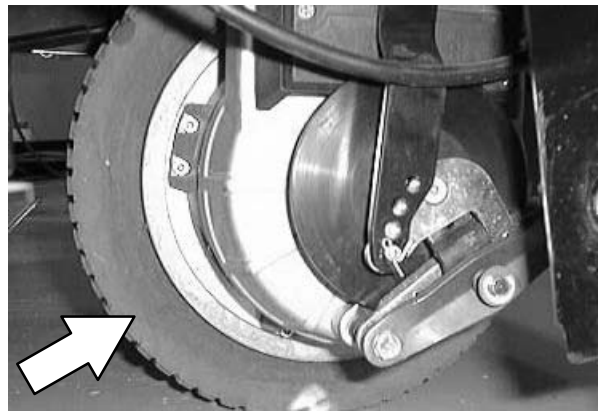

6. Remove the four hex screws holding the front drive pivot assembly to the upper drive casting. *Note the location of the spacers.*

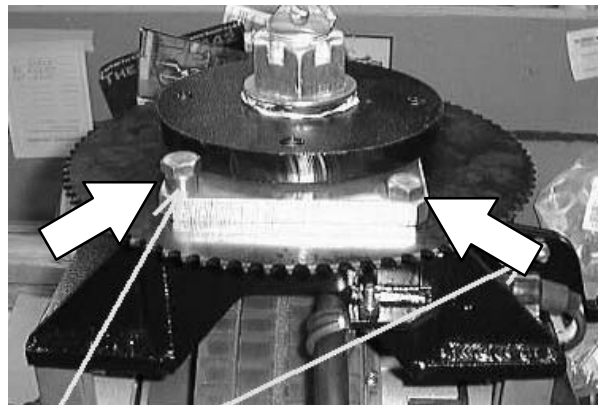

7. Remove the small thread roller screw holding the castle nut to the pivot shaft. Remove the castle nut and flat washer.

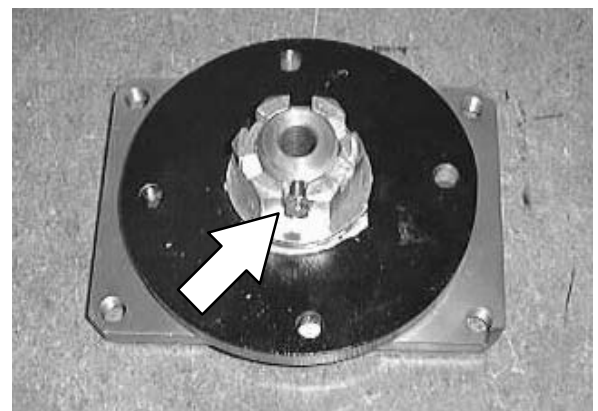

## CHASSIS

- Pull the cone bearing out of the swivel plate.

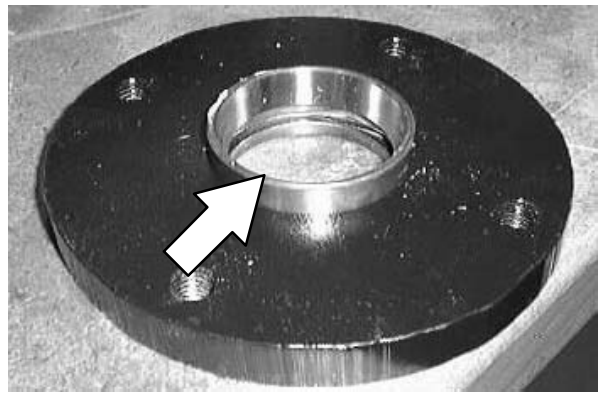

- Pull the swivel plate off the swivel plate weldment. Make sure to retain the rubber seal ring.

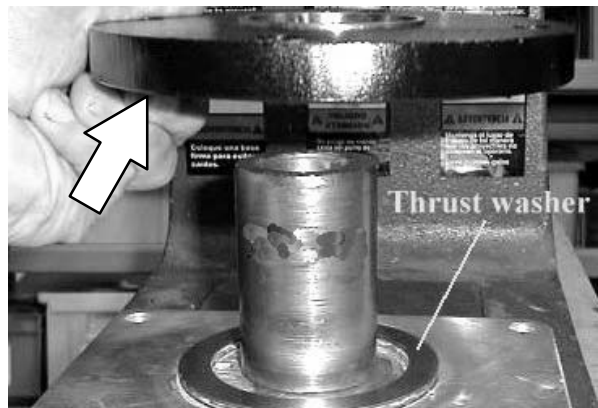

- Remove and discard the upper thrust washer. Remove and discard the needle bearing and lower thrust washer.

- Install the new thrust washer onto the swivel plate weldment.

- Grease the new needle bearing and position on top of the new thrust washer. Install the second thrust washer on top of the needle bearing.

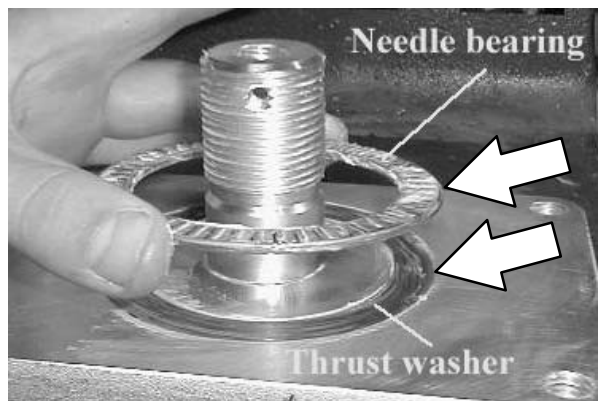

- Reinstall the swivel plate onto the swivel plate weldment. **Make sure the rubber seal ring is in place on the swivel plate before installing.**

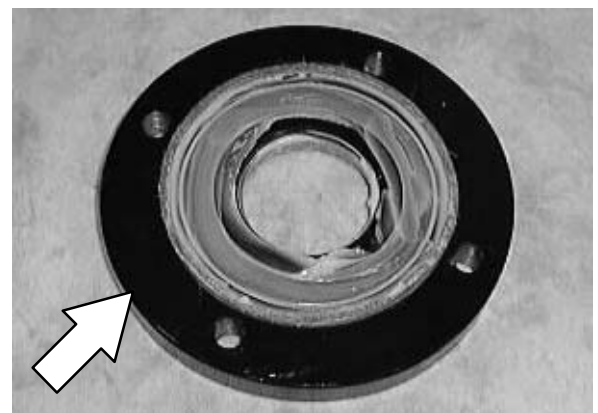



14. Reinstall the cone bearing in the swivel plate. *Grease the bearing if needed.*

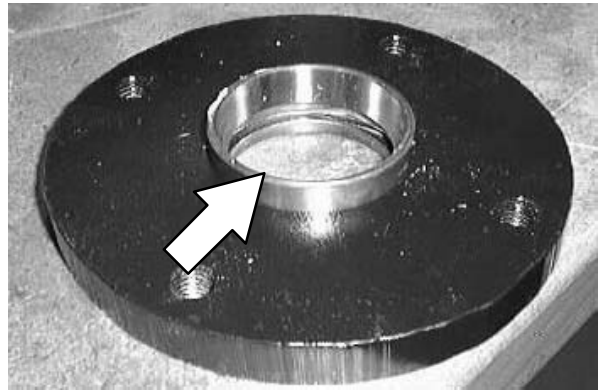

15. Reinstall the large flat washer and castle nut. Tighten to 37 – 48 Nm (26 – 34 ft. lb). Reinstall the small thread roller into the cross hole. *Back off the castle nut if needed to align cross hole.*

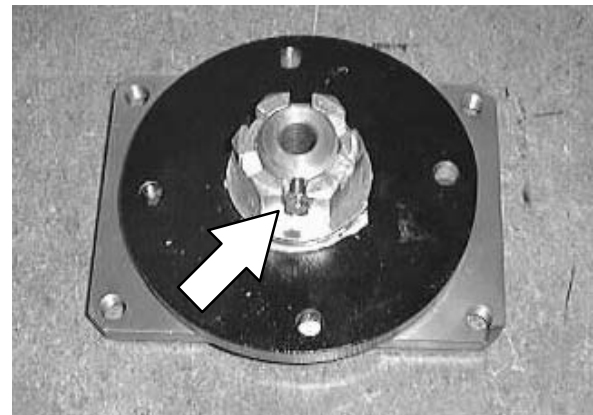

16. Position the front drive pivot assembly onto the large sprocket. Install the four hex screws and one spacer. Use blue loctite 242 on the threads. Tighten to 37 – 48 Nm (26 – 34 ft lb).

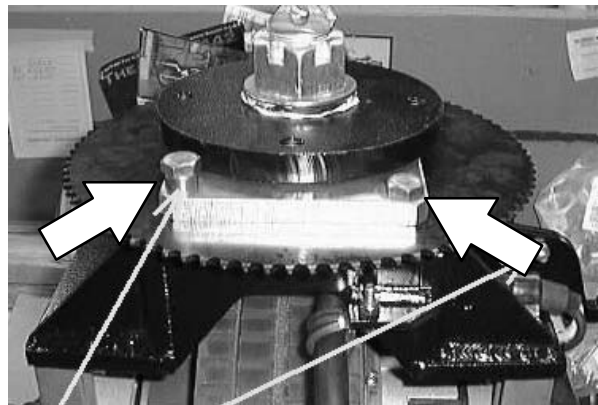

17. Reinstall the front drive assembly. See TO INSTALL FRONT DRIVE ASSEMBLY instructions in this section.

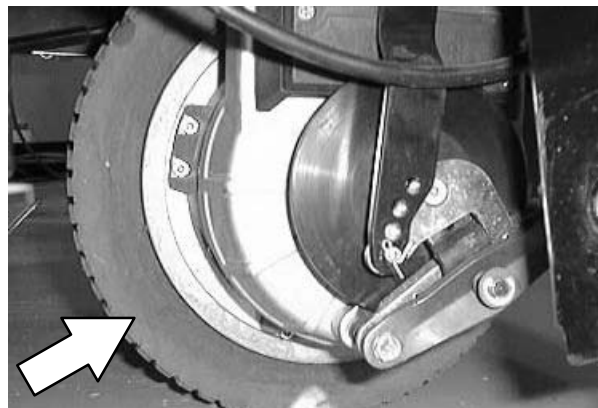

## CHASSIS

18. Reinstall the steering chain onto both steering sprockets. Reinstall the master link.

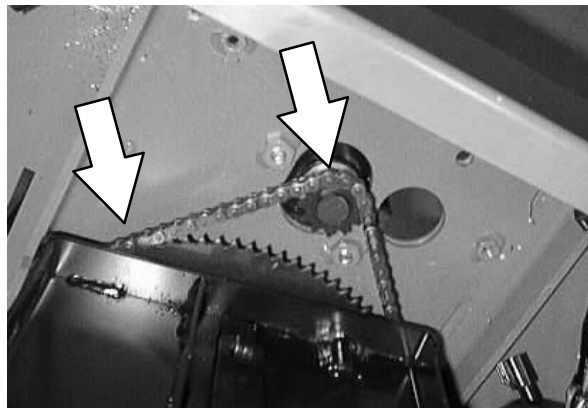

19. Turn the steering wheel all the way to the left and then to the right. Find the point in the rotation where the steering chain is the most tight.

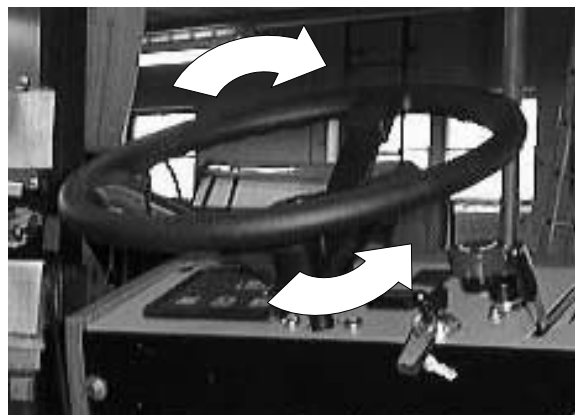

20. Push the bearing housing forward in the slots. This will remove any excess slack in the steering chain. Tighten the two hex screws to 37 – 48 Nm (26 – 34 ft lb).

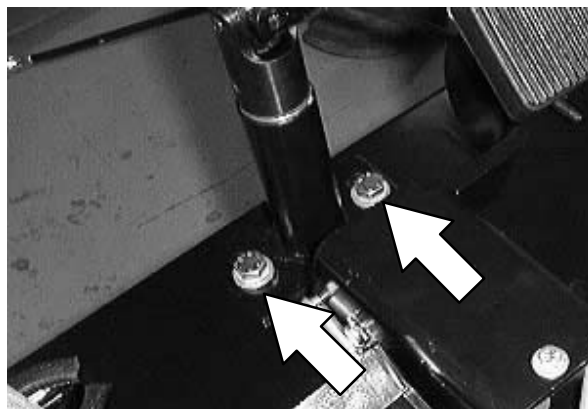

21. Remove the jack stands and lower the machine to the floor. Operate the machine and check the steering for proper operation.

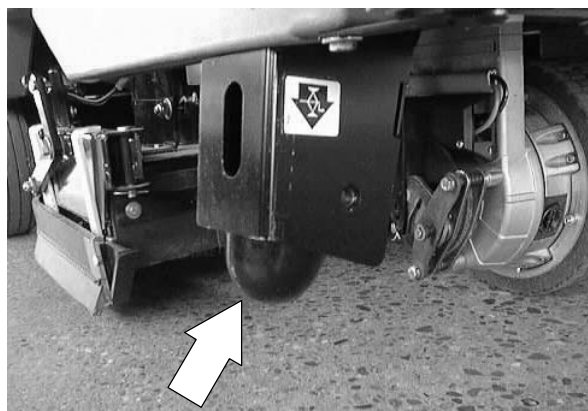

**TO REPLACE FRONT WHEEL HOUSING  
CONE BEARING**

**FOR SAFETY: Before Leaving Or Servicing Machine; Stop On Level Surface, place blocks in front and back of the rear tires.**

1. Jack up the front of the machine at the jack point. Install jack stands under the machine frame.

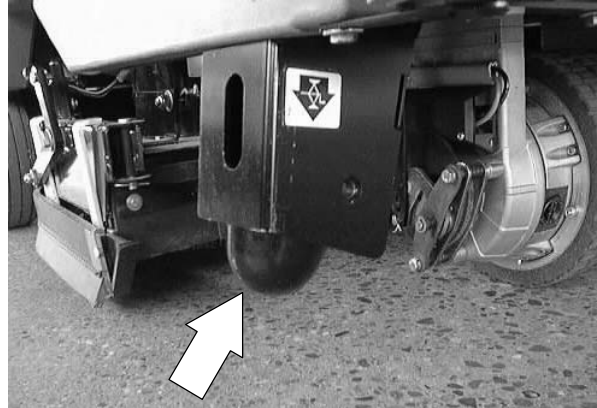

2. Turn the steering wheel all the way to the left.

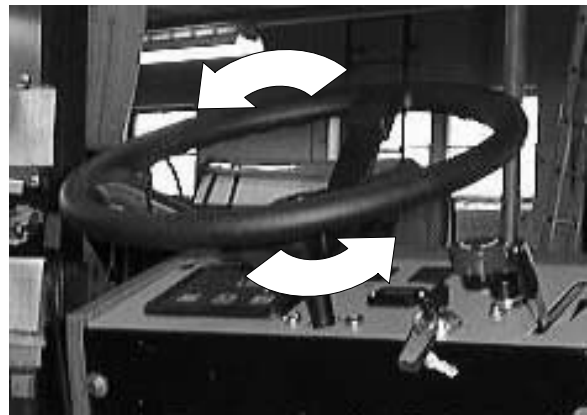

3. Go to the operators compartment and locate the two hex screws holding the steering bearing housing to the machine frame. Loosen the two screws and push the bearing housing back in the slots. *This will loosen the steering chain.*

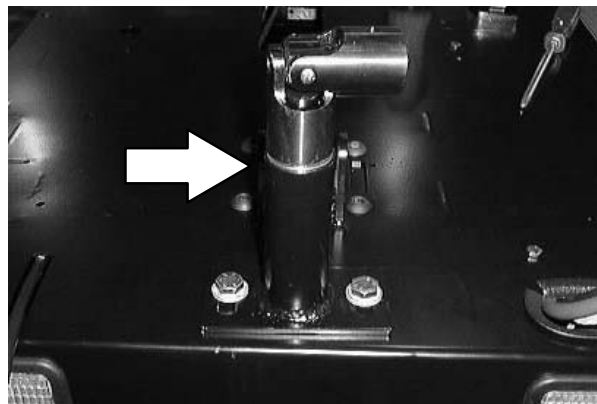

## CHASSIS

4. Locate the master link on the steering chain. Remove the master link from the steering chain. Remove the steering chain from the machine.

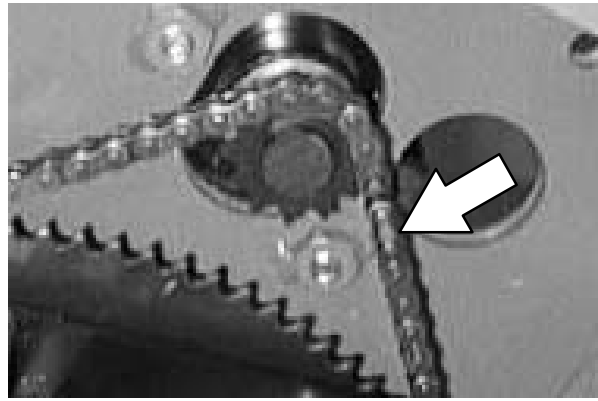

5. Remove the front drive assembly. See TO REMOVE FRONT DRIVE ASSEMBLY instructions in this section.

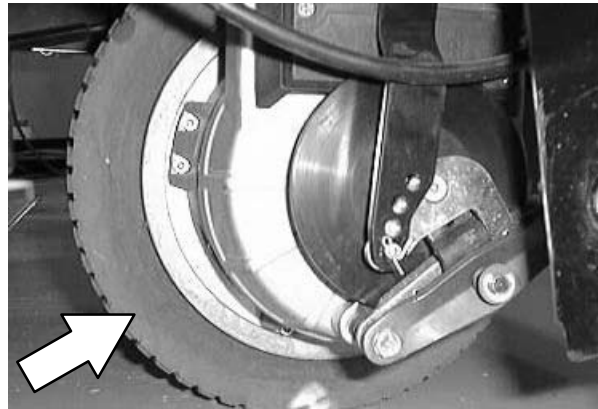

6. Remove the four hex screws holding the front drive pivot assembly to the upper drive casting. *Note the location of the spacers.*

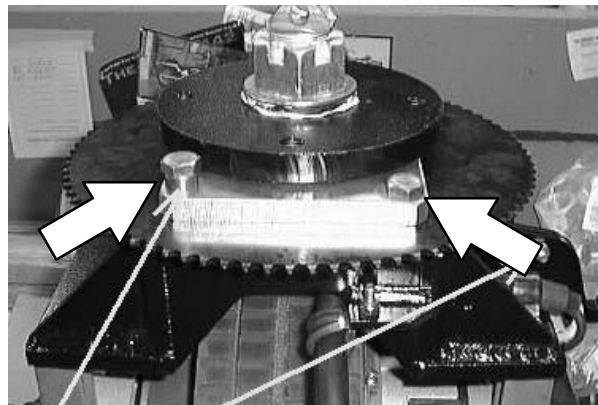

7. Remove the small thread roller screw holding the castle nut to the pivot shaft. Remove the castle nut and flat washer.

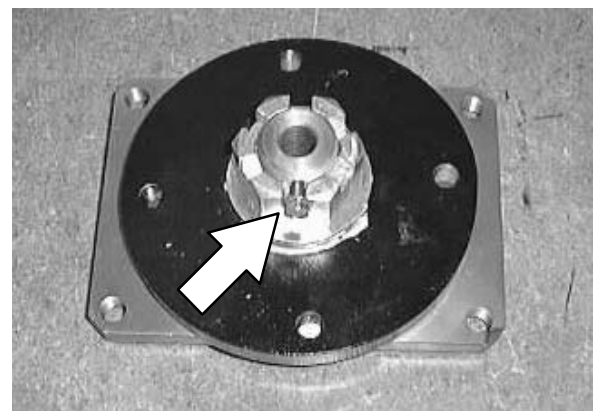

8. Pull the cone bearing out of the swivel plate.

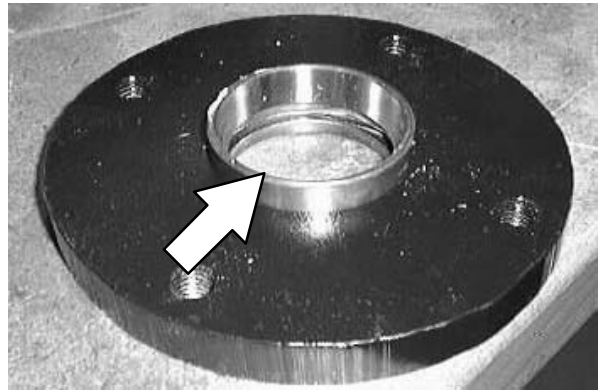

9. Pull the swivel plate off the swivel plate weldment. Make sure to retain the rubber seal ring.

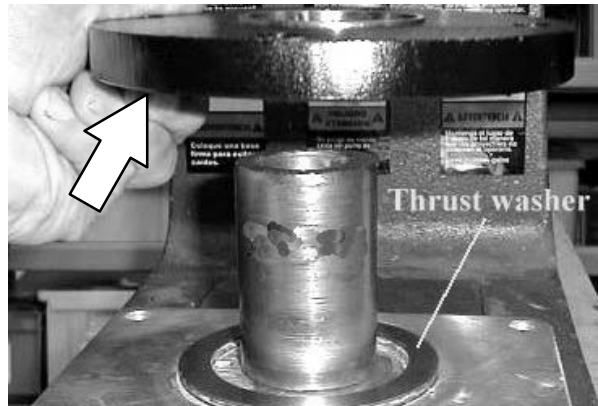

10. Reinstall the swivel plate onto the swivel plate weldment. **Make sure the rubber seal ring is in place on the swivel plate before installing.**

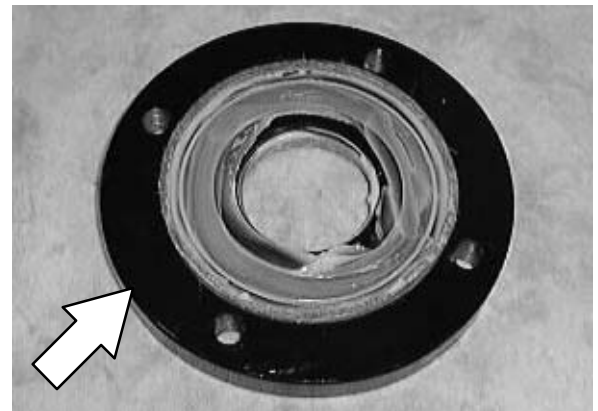

11. Reinstall the cone bearing in the swivel plate. *Grease the bearing if needed.*

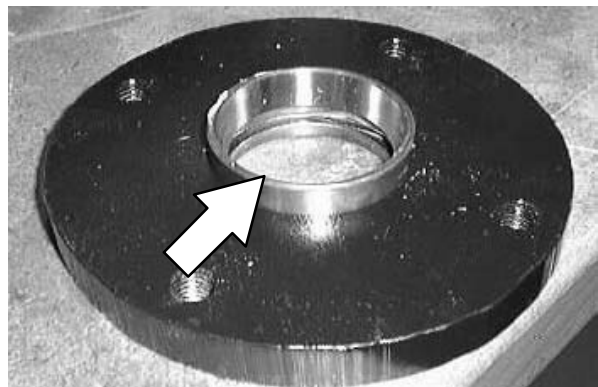

## CHASSIS

12. Reinstall the large flat washer and castle nut. Tighten to 37 – 48 Nm (26 – 34 ft. lb). Reinstall the small thread roller into the cross hole. *Back off the castle nut if needed to align cross hole.*

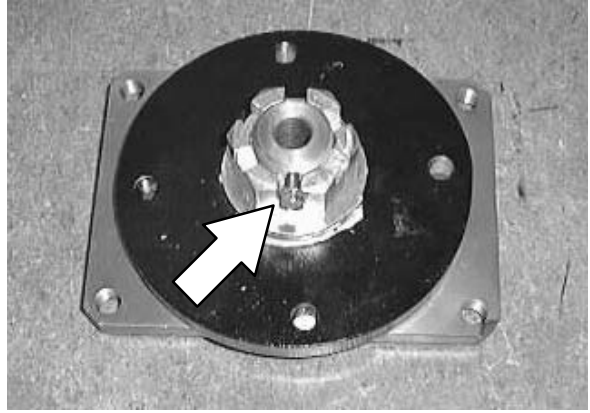

13. Position the front drive pivot assembly onto the large sprocket. Install the four hex screws and one spacer. Use blue loctite 242 on the threads. Tighten to 37 – 48 Nm (26 – 34 ft lb).

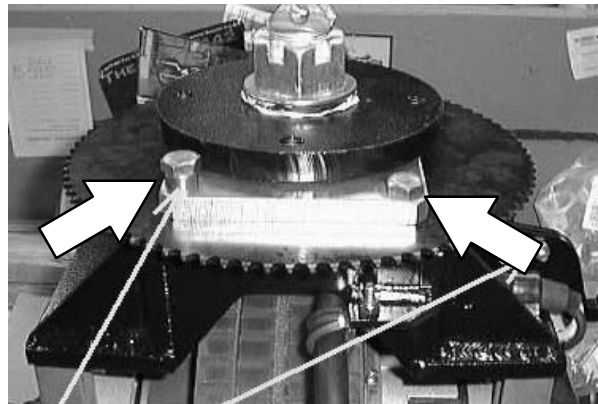

14. Reinstall the front drive assembly. See TO INSTALL FRONT DRIVE ASSEMBLY instructions in this section.

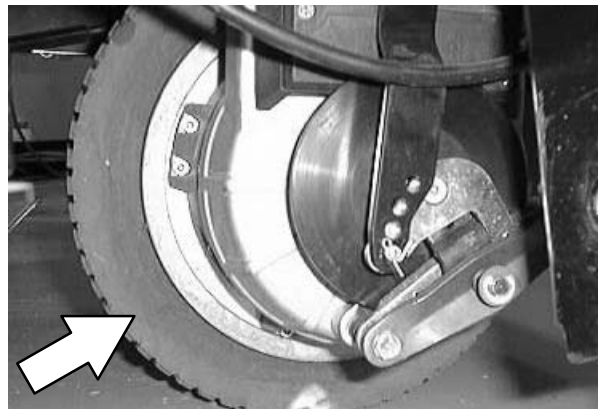

15. Reinstall the steering chain onto both steering sprockets. Reinstall the master link.

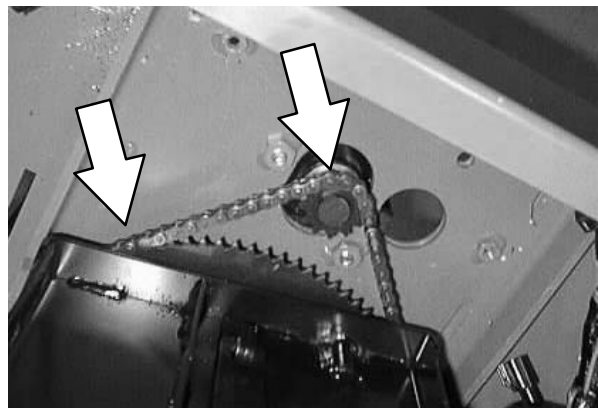

16. Turn the steering wheel all the way to the left and then to the right. Find the point in the rotation where the steering chain is the most tight.

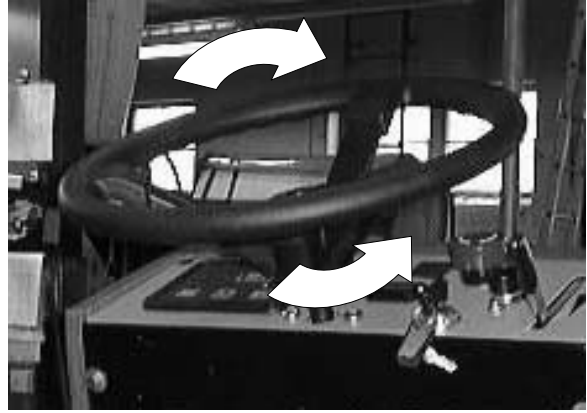

17. Push the bearing housing forward in the slots. This will remove any excess slack in the steering chain. Tighten the two hex screws to 37 – 48 Nm (26 – 34 ft lb).

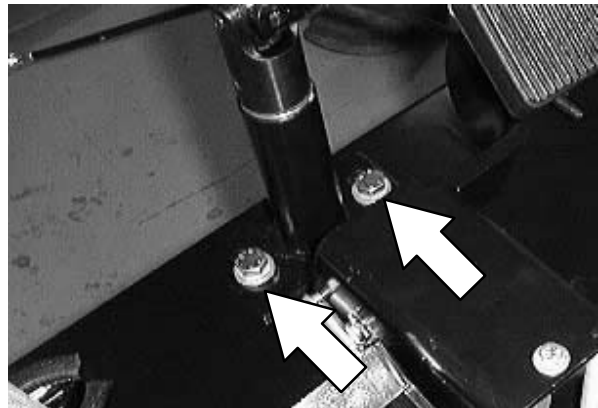

18. Remove the jack stands and lower the machine to the floor. Operate the machine and check the steering for proper operation.

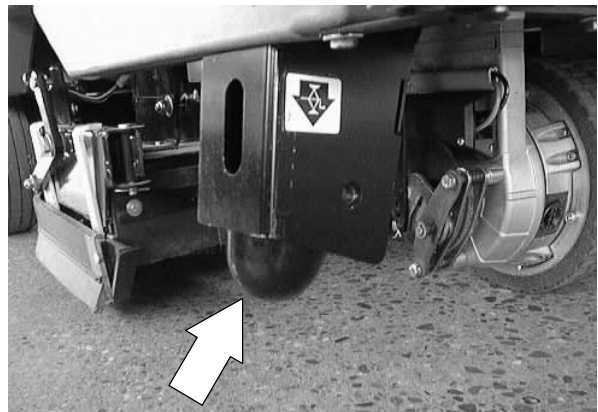





**CONTENTS**

	Page		Page
INTRODUCTION .....	3-3	TO REMOVE REAR SQUEEGEE	
SOLUTION TANK .....	3-4	ASSEMBLY .....	3-75
TO DRAIN AND CLEAN SOLUTION		TO INSTALL REAR SQUEEGEE	
TANK WITH ES™ .....	3-5	ASSEMBLY .....	3-77
TO REMOVE SOLUTION TANK .....	3-8	TO LEVEL REAR SQUEEGEE .....	3-79
TO INSTALL SOLUTION TANK .....	3-12	TO ADJUST REAR SQUEEGEE BLADE	
RECOVERY TANK .....	3-17	DEFLECTION .....	3-81
TO DRAIN AND CLEAN RECOVERY		REAR SQUEEGEE CASTERS .....	3-83
TANK .....	3-18	TO ADJUST REAR SQUEEGEE GUIDE	
TO REMOVE RECOVERY TANK .....	3-21	ROLLER .....	3-83
TO INSTALL RECOVERY TANK .....	3-26	REAR SQUEEGEE SPRINGS .....	3-83
SCRUB HEAD .....	3-31	REAR SQUEEGEE BLADES .....	3-84
SCRUB HEAD LINKS .....	3-32	TO REPLACE OR ROTATE REAR	
TO REPLACE SCRUB HEAD LINKS .....	3-33	SQUEEGEE (REAR) BLADE ..	3-84
TO REMOVE DISC SCRUB HEAD ..	3-34	TO REPLACE OR ROTATE REAR	
TO INSTALL DISC SCRUB HEAD ...	3-36	SQUEEGEE (FRONT) BLADE	3-86
TO REMOVE CYLINDRICAL SCRUB		SIDE SQUEEGEE BLADES .....	3-89
HEAD .....	3-38	TO REPLACE SIDE SQUEEGEE	
TO INSTALL CYLINDRICAL SCRUB		BLADES .....	3-90
HEAD .....	3-40	VACUUM FAN .....	3-92
DISC SCRUB HEAD SKIRTS .....	3-42	TO REMOVE VACUUM FAN	
SCRUB HEAD FLOOR SKIRTS .....	3-42	ASSEMBLY .....	3-92
TO ADJUST DISC SCRUB		TO INSTALL VACUUM FAN	
HEAD SKIRTS .....	3-42	ASSEMBLY .....	3-94
TO REPLACE DISC SCRUB HEAD		MACHINE TROUBLESHOOTING .....	3-96
SKIRTS .....	3-44		
CYLINDRICAL BRUSH HEAD			
DEBRIS TRAY .....	3-45		
TO REMOVE DEBRIS TRAY .....	3-45		
TO INSTALL DEBRIS TRAY .....	3-47		
TO REPLACE DEBRIS TRAY SKIRT	3-48		
SCRUB BRUSHES .....	3-49		
DISC SCRUB BRUSHES .....	3-49		
TO REPLACE DISC SCRUB			
BRUSHES .....	3-49		
CYLINDRICAL SCRUB BRUSHES ..	3-51		
TO REPLACE CYLINDRICAL SCRUB			
BRUSHES .....	3-51		
TO CHECK AND ADJUST CYLINDRICAL			
BRUSH PATTERN .....	3-54		
CYLINDRICAL BRUSH DRIVE BELT ...	3-57		
TO REPLACE BRUSH DRIVE BELT ..	3-57		
TO REPLACE BRUSH DRIVE PLUG			
BEARINGS .....	3-62		
TO REPLACE BRUSH IDLER PLUG ..	3-64		
TO REPLACE SCRUB HEAD LIFT ARM			
BEARINGS (ROLL-OUT BATTERY			
OPTION MACHINES ONLY) ..	3-67		
MANUAL SOLUTION VALVE .....	3-70		
TO REPLACE SOLUTION VALVE ...	3-70		
SQUEEGEES .....	3-74		
SQUEEGEE WHEEL CAMS .....	3-74		
SQUEEGEE LEVELING KNOB .....	3-74		



**INTRODUCTION**

When scrubbing, the water flows from the solution tank, through the solution valve, and down to the scrub brushes. The brushes scrub the floor. As the machine moves forward the rear squeegee wipes the dirty solution off the floor, which is then picked up and drawn into the recovery tank by the vacuum fan.

## SOLUTION TANK

The solution tank supplies the brushes with a water and detergent solution. The solution tank is located to the right of the recovery tank and behind the operators seat.

Access to the solution tank is through the opening at the top of the tank, reached by lifting up the tank cover.

The solution tank requires no regular maintenance. If detergent cakes on the bottom of the tank, remove the deposits with a strong blast of warm water. Do not use water hotter than 130° F (54° C) or use steam to clean the tank because damage may occur. A tank drain hose has been provided to allow the tank to be drained for cleaning.

The solution tanks with ES™ should be drained and cleaned after every work shift.



**TO DRAIN AND CLEAN SOLUTION TANK WITH ES™**

1. Close the solution tank water valve.

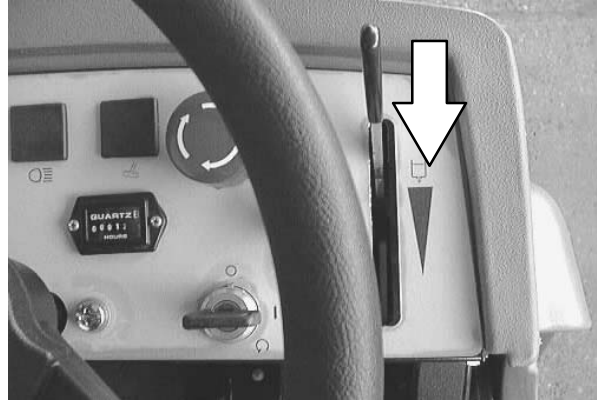

2. Raise the scrub head and rear squeegee.

3. Stop the machine next to a floor drain.

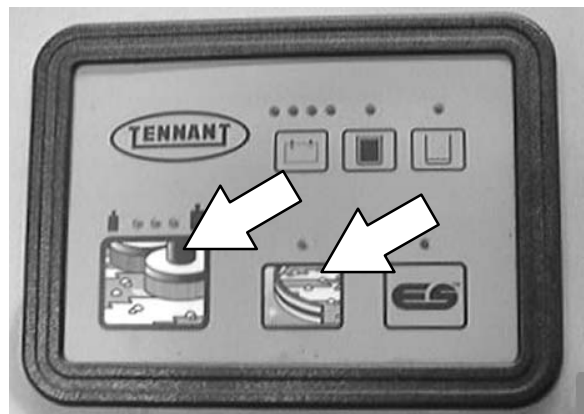

4. Shut off the machine and set the parking brake.

**FOR SAFETY: Before Leaving Or Servicing Machine; Stop On Level Surface, Set Parking Brake.**



## SCRUBBING

5. Remove the drain hose cap from the access caps at the rear of the solution tank.

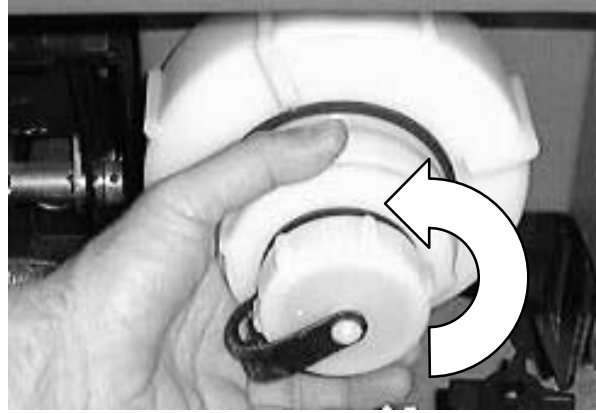

6. Pull the tank drain hoses out and place them over the floor drain. Remove the drain cap from the end of the hose. Drain the tanks.

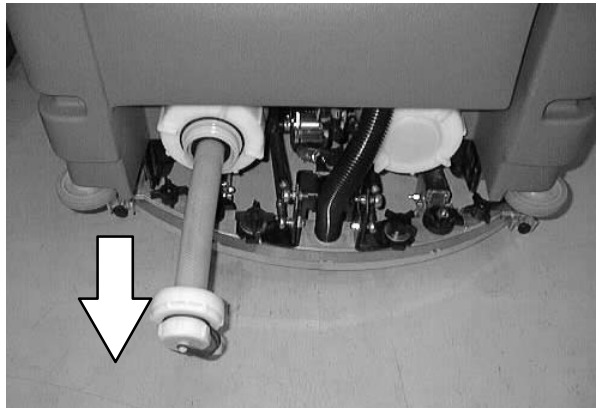

7. Open the tank cover.

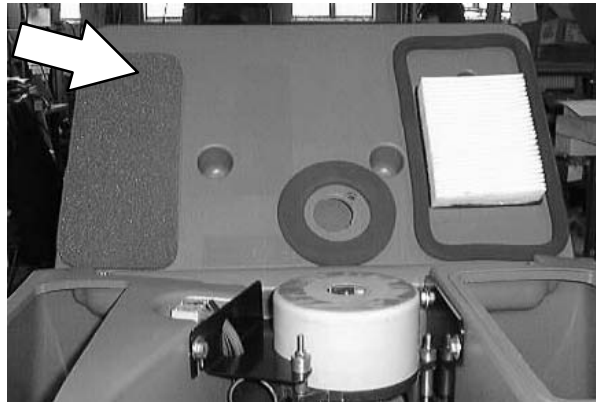

8. Spray the inside of the solution and recovery tanks with a strong blast of warm water. Do not use water hotter than 130° F (54° C) or use steam to clean the tank because damage may occur. Remove the ES™ outlet filter, clean, reinstall.

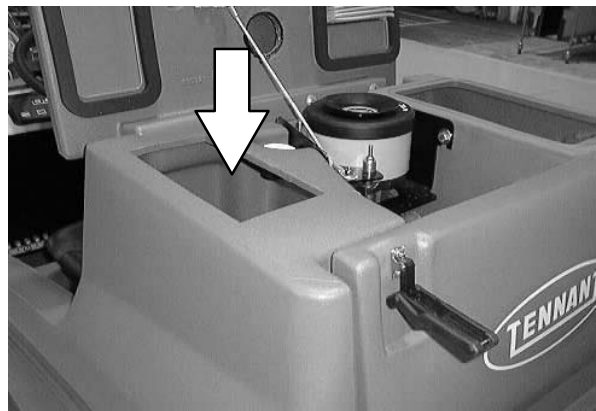

9. Check the vacuum fan filter on top of the recovery tank. Clean or replace if necessary.

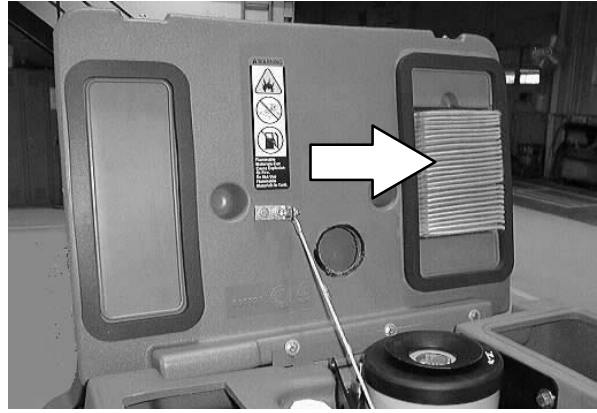

10. Close the tank cover.



11. Replace the drain hose in the tank.

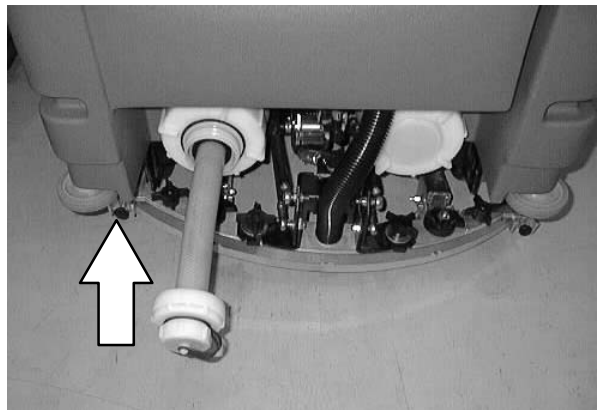

## SCRUBBING

### TO REMOVE SOLUTION TANK

**FOR SAFETY: Before Leaving Or Servicing Machine; Stop On Level Surface, Set Parking Brake.**

1. Make sure the solution tank has been drained.
2. Raise the seat support and engage the prop rod.

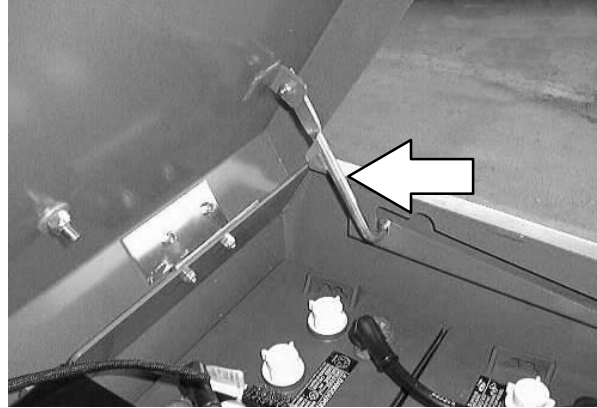

3. Disconnect the battery connector from the machine.

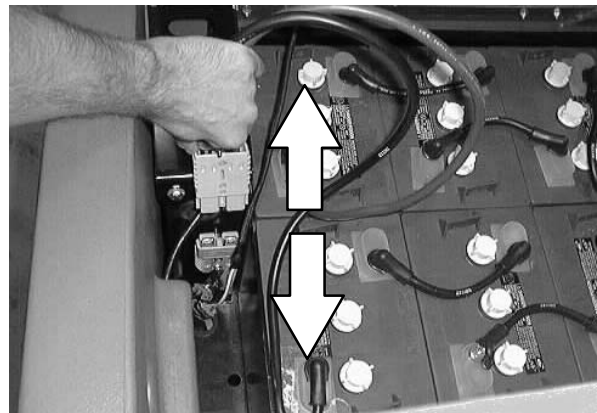

4. Remove the battery cables leading to the middle battery on the left side of the machine. Remove the middle, left battery from the machine.

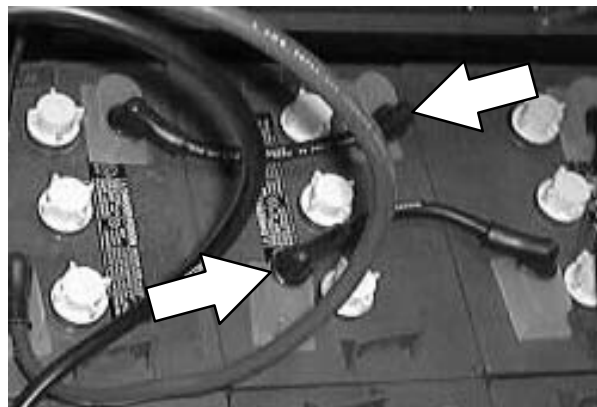



5. Push the left, front battery back for access to the lower solution tank hardware. *Note: If machine is equipped with the roll-out battery option--roll the battery tray out far enough to access the solution tank hardware. See TO REMOVE ROLL OUT BATTERY instructions in the ELECTRICAL section.*



6. Remove the three hex screws holding the solution tank to the frame.

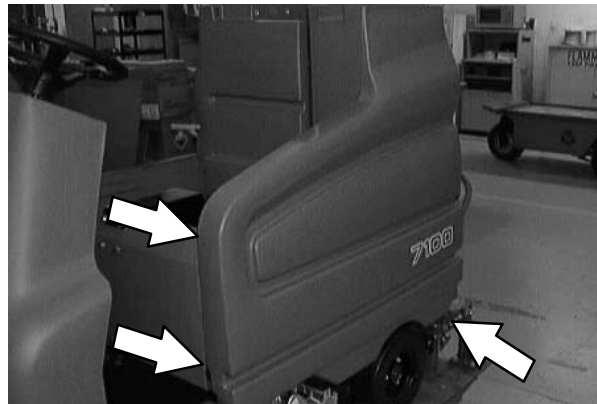

7. Open the tank cover.

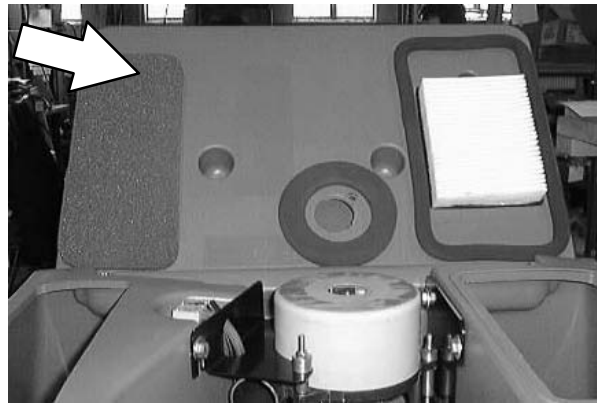

8. Remove the three hex screws holding the vacuum fan assembly to the solution and recovery tanks. Lift the vacuum fan up and disconnect the electrical plug from the main harness. remove the vacuum fan from the machine.

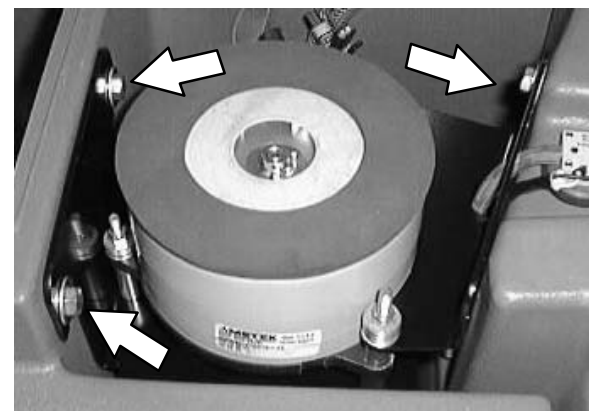

## SCRUBBING

9. If the machine is equipped with the ES option--remove the check valve and hose from the top of the solution tank.

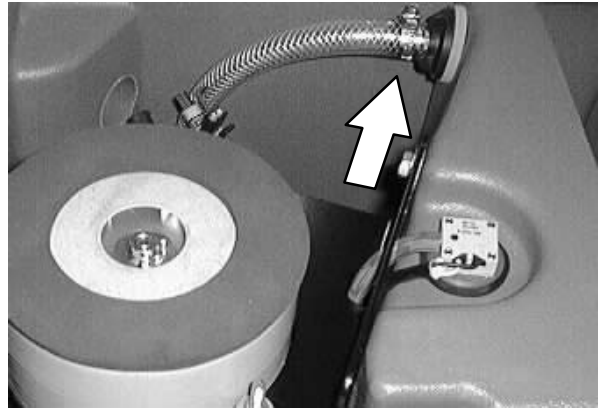

10. Remove the clamp holding the wire harness to the side of the solution tank.

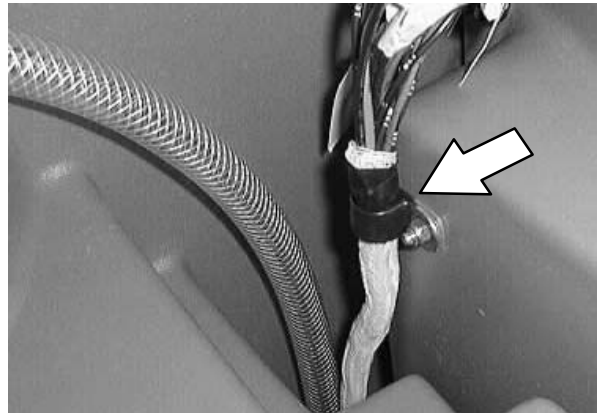

11. If the machine is equipped with the ES option--disconnect the float switch.



12. Remove the hex screws holding the "L" bracket to the solution and recovery tanks.

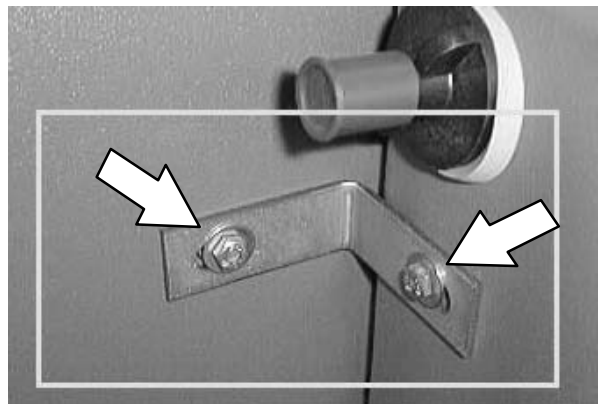

13. Remove both drain hoses from the tanks.

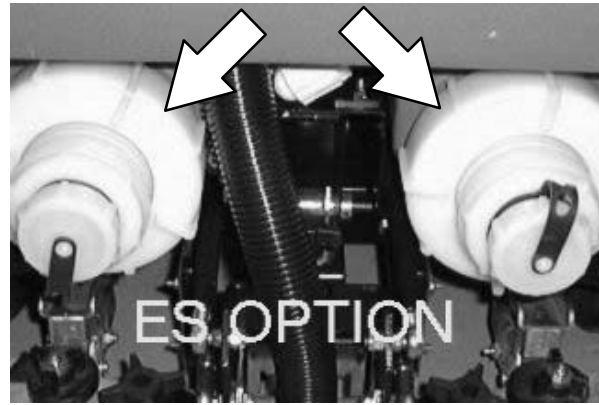

14. Remove the hardware holding the drip tray to the back of the tanks. Remove the drip tray from the machine.

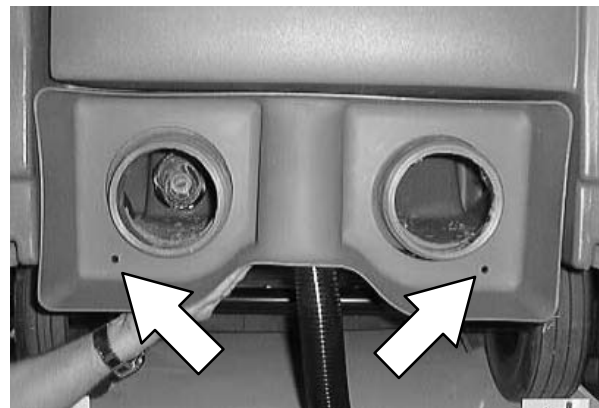

15. Lift the solution tank up far enough to access the clamp on the hose running from the bottom of the solution tank to the water valve. Loosen this clamp and remove the hose from the solution tank.

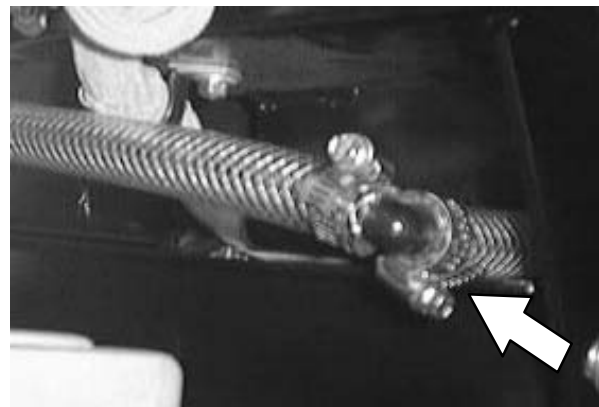

16. The solution tank can now be removed from the machine.

## SCRUBBING

### TO INSTALL SOLUTION TANK

**FOR SAFETY: Before Leaving Or Servicing Machine; Stop On Level Surface, Set Parking Brake.**

1. Position the solution tank on the left side edge of the machine frame.

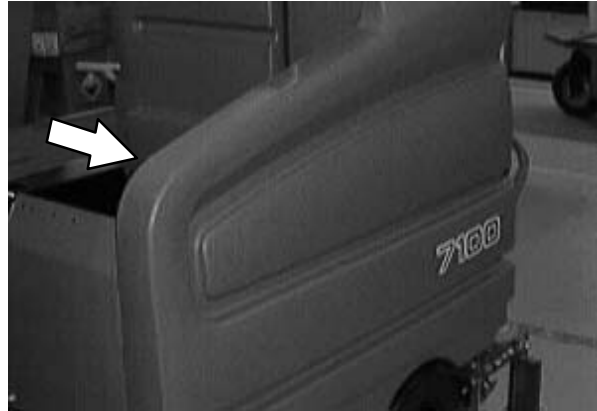

2. Drop the solution tank down in place. *Be careful to route the electrical harness properly. Route the tank hose through the cut out in the frame.* Reinstall the three hex screws holding the solution tank to the machine frame. Tighten the screws to 18 – 24 Nm (15 – 20 ft lb).

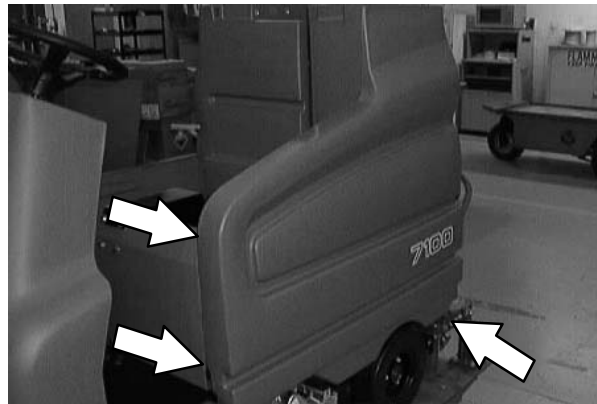

3. Connect the hose coming from the solution tank to the hose leading to the water valve. Tighten the worm drive clamp.

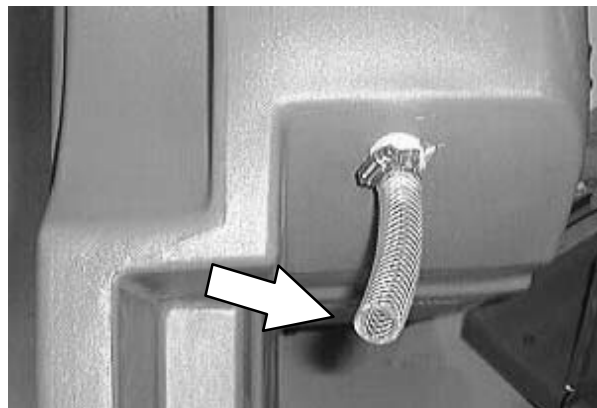

4. Reinstall the “L” bracket to the solution and recovery tanks. Tighten the screws to 18 – 24 Nm (15 – 20 ft lb).

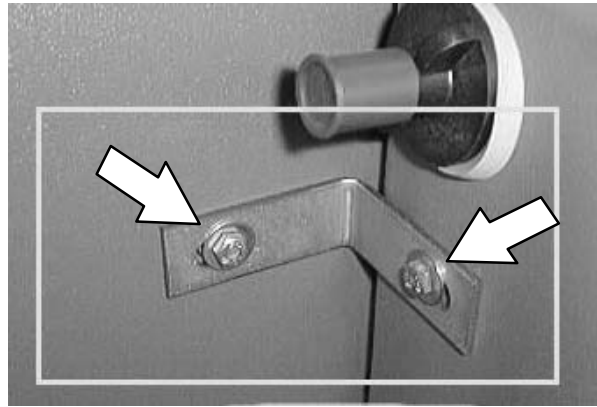

5. Reinstall the check valve and hose in the solution tank.

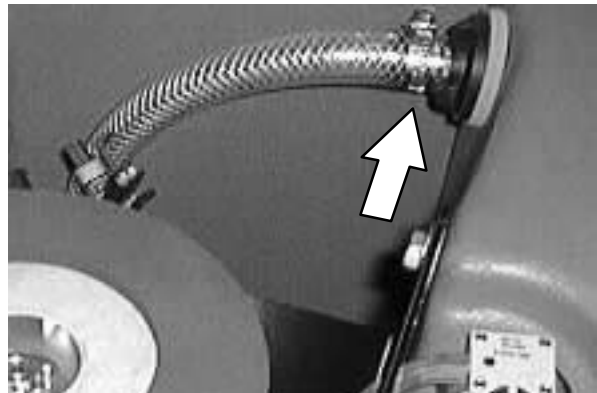

6. If the machine is equipped with the ES option--reconnect the float switch.



7. Reinstall the clamp holding the wire harness to the side of the solution tank.

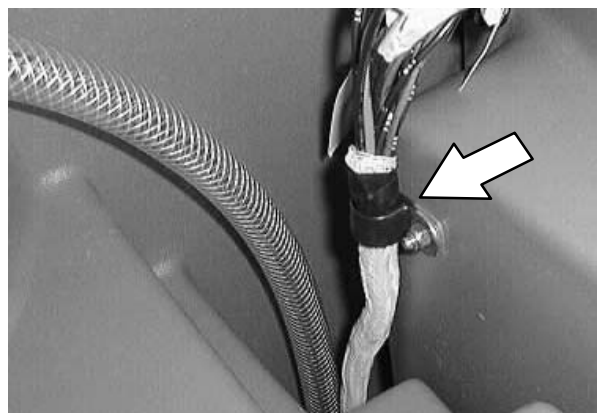

## SCRUBBING

8. Reinstall the vacuum fan assembly. Connect the vacuum fan to the main harness before installing the hardware. Tighten the three hex screws to 18 – 24 Nm (15 – 20 ft lb).

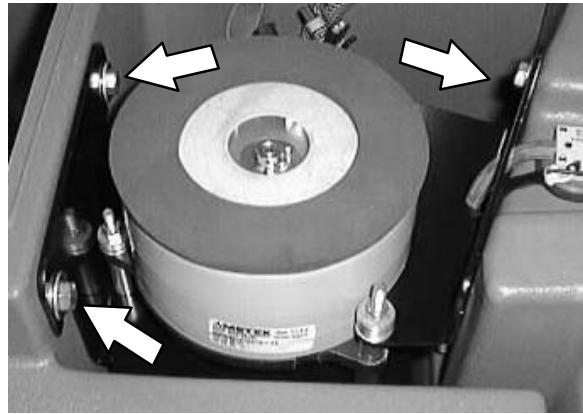

9. Close the tank cover and engage the cover latches.

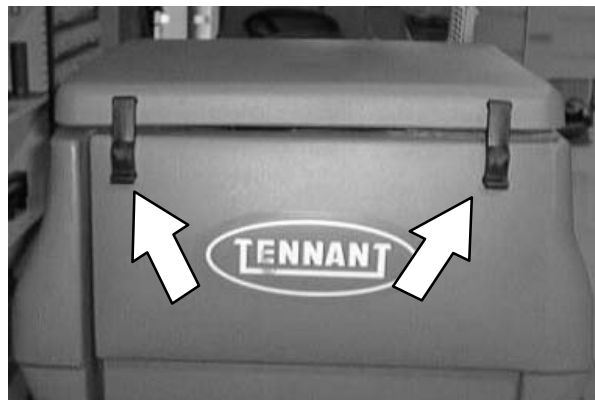

10. Push the front, left battery forward in the battery tray.

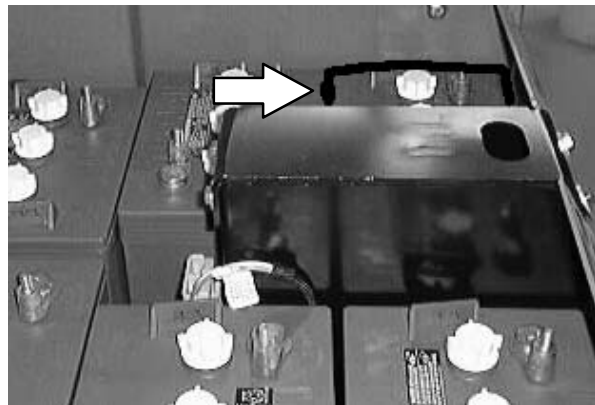

11. Reinstall the battery in the left, middle space in the battery tray. Reconnect the two battery cables.

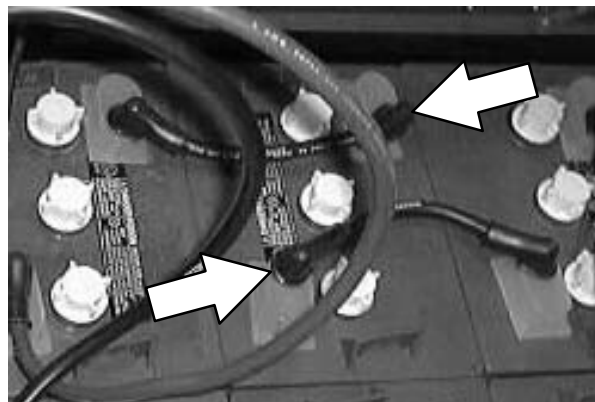

12. Reconnect the battery connector.

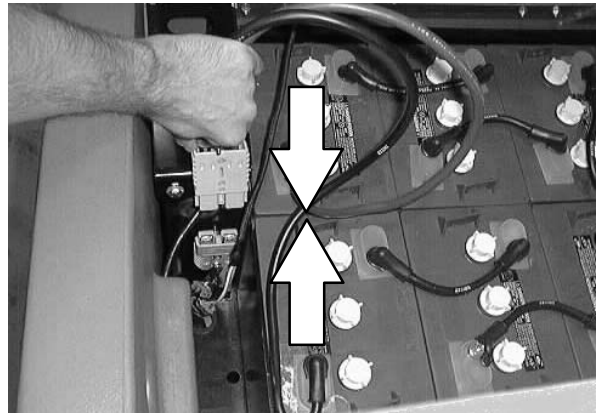

13. Close the seat support.



14. Reinstall the drip tray. Tighten the two hex screws to 18 – 24 Nm (15 – 20 ft lb).

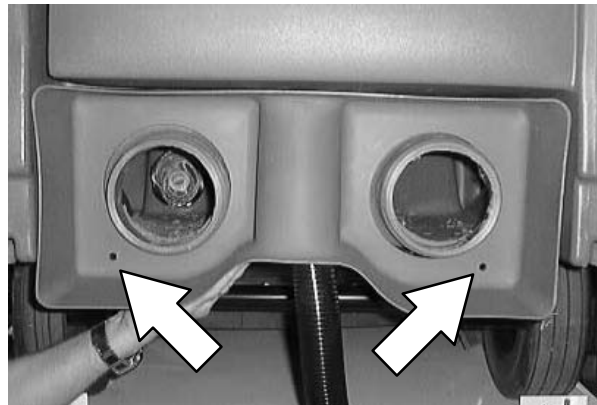

15. Replace both drain hoses in the tanks.

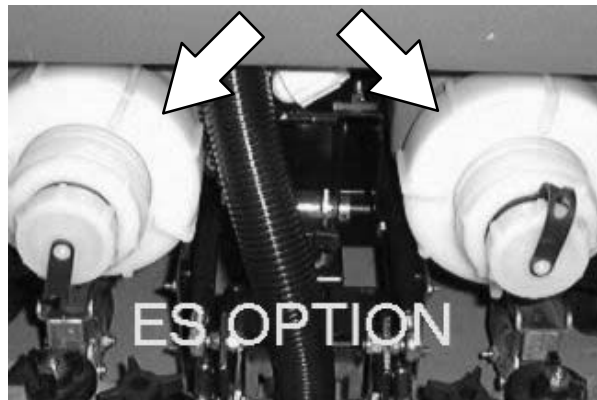

## SCRUBBING

16. Start the machine. Fill the solution tank with water and check the hose connections for leaks.

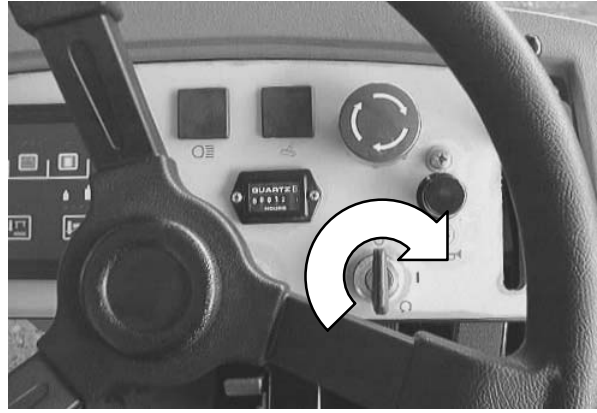



---

**RECOVERY TANK**

---

The recovery tank stores the water solution picked up by the squeegees and vacuum fan. The recovery tank is located at the left, rear corner of the machine, on the left of the solution tank.

The recovery tank should be drained and cleaned after the solution tank is empty and whenever the float switch stops the vacuum fan or the recovery full light comes on.



## SCRUBBING

### TO DRAIN AND CLEAN RECOVERY TANK

1. Close the solution tank water valve.

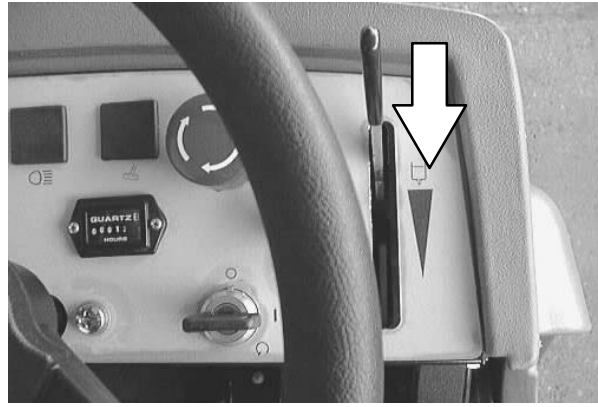

2. Raise the scrub head and rear squeegee.

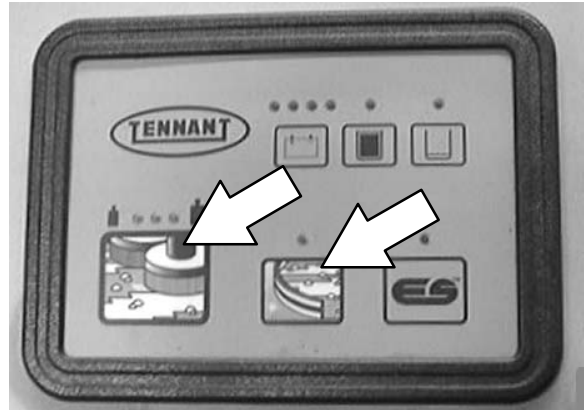

3. Stop the machine next to a floor drain.

4. Shut off the machine and set the parking brake.

**FOR SAFETY: Before Leaving Or Servicing Machine; Stop On Level Surface, Set Parking Brake.**



5. Remove the drain hose cap from the access caps at the rear of the solution tank.

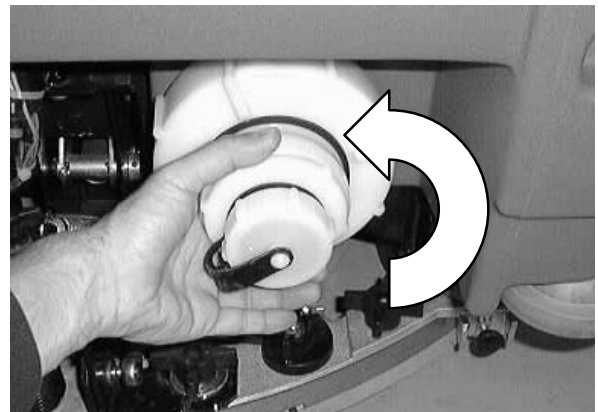

- Pull the tank drain hoses out and place them over the floor drain. Remove the drain cap from the end of the hose. Drain the tanks.

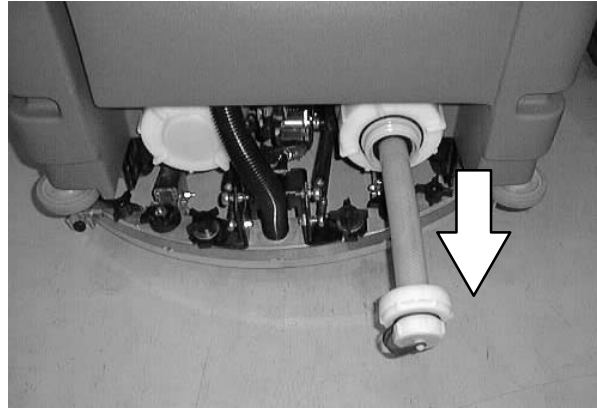

- Open the tank cover.

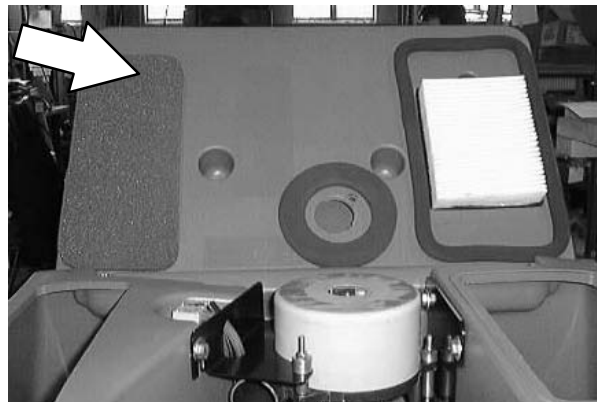

- Spray the inside of the solution and recovery tanks with a strong blast of warm water. Do not use water hotter than 130° F (54° C) or use steam to clean the tank because damage may occur. Remove the ES™ outlet filter, clean, reinstall.

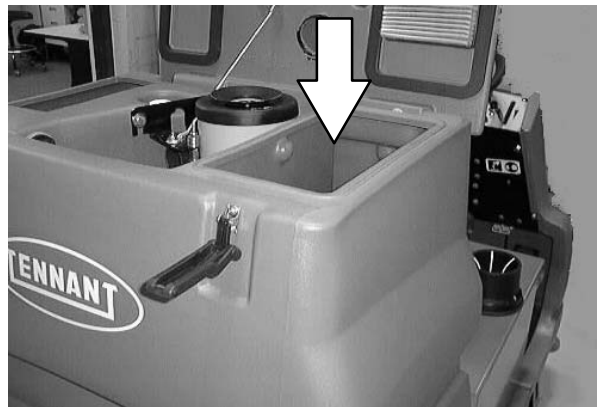

- Check the vacuum fan filter on top of the recovery tank. Clean or replace if necessary.

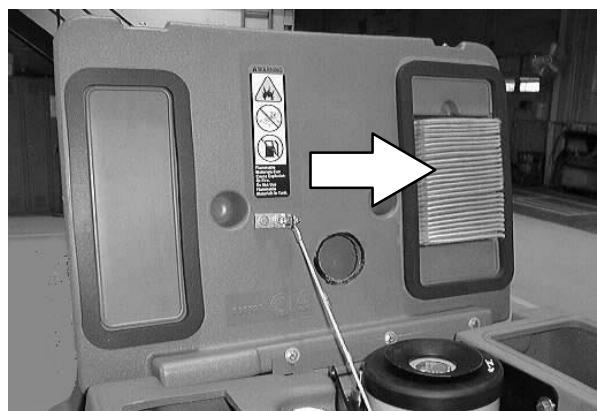

## SCRUBBING

10. Close the tank cover.

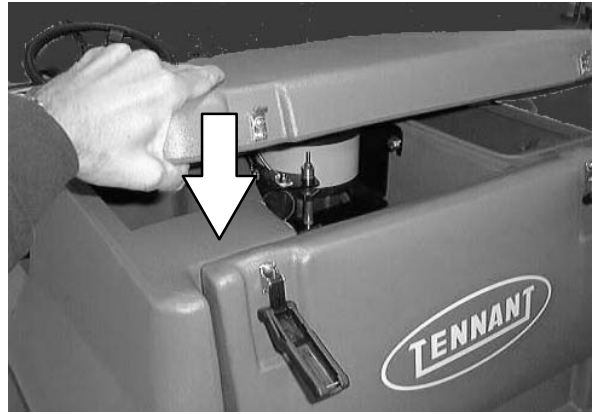

11. Reinstall the drain hose in the tank.

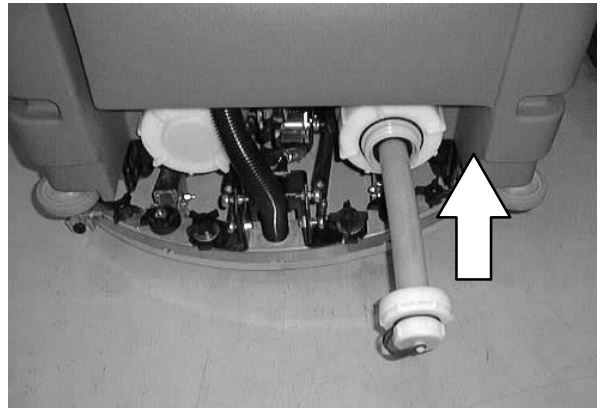

**TO REMOVE RECOVERY TANK**

**FOR SAFETY: Before Leaving Or Servicing Machine; Stop On Level Surface, Set Parking Brake.**

1. Make sure the recovery tank has been drained.
2. Raise the seat support and engage the prop rod.

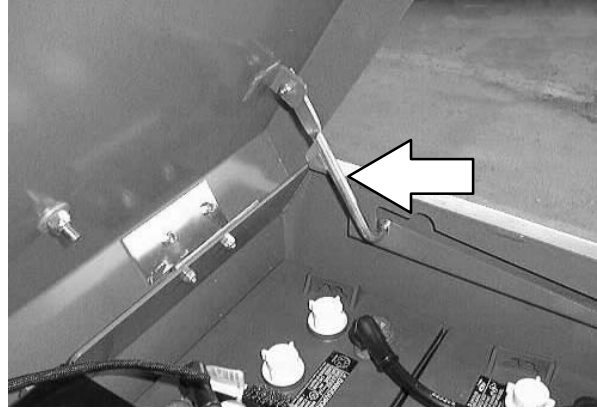

3. Disconnect the battery connector from the machine.

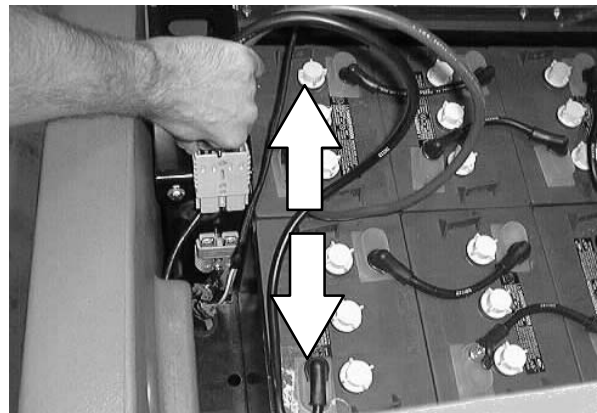

4. Remove the battery cables leading to the middle battery on the right side of the machine. Remove the middle, right battery from the machine.

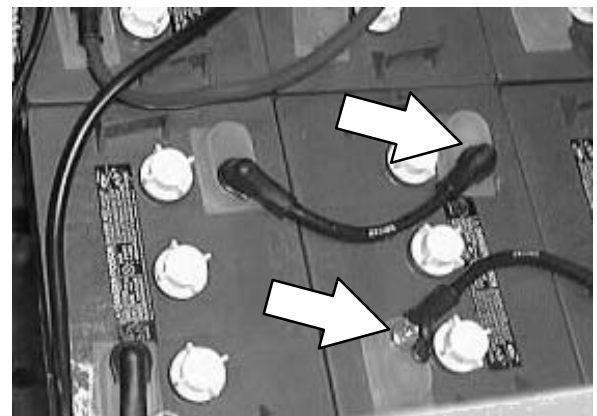

## SCRUBBING

5. Push the right, rear battery forward for access to the lower recovery tank hardware.

*NOTE: If machine is equipped with the roll-out battery option—roll the battery tray out far enough to access the solution tank hardware. See TO REMOVE ROLL OUT BATTERY instructions in the ELECTRICAL section.*



6. Remove the three hex screws holding the recovery tank to the machine frame.

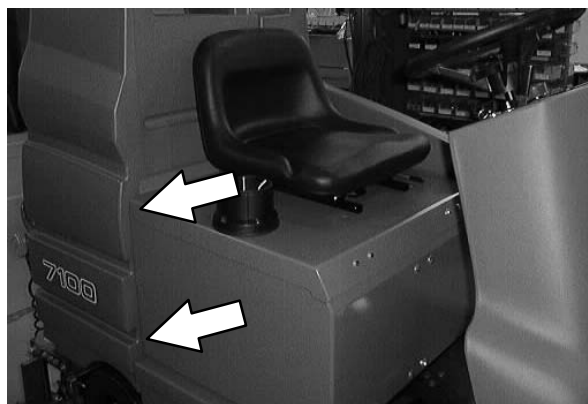

7. Open the tank cover.

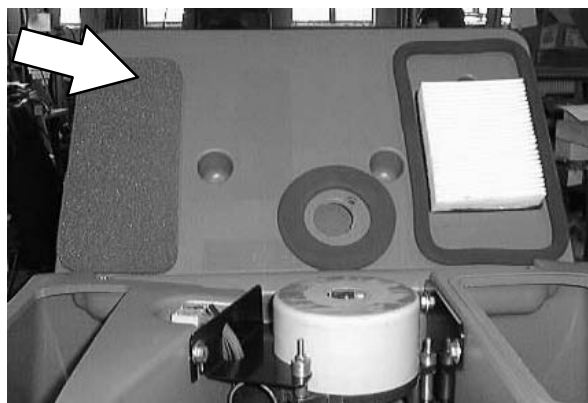

8. Remove the hex screw from the end of the cover cable where it attaches at the vacuum fan mount plate.

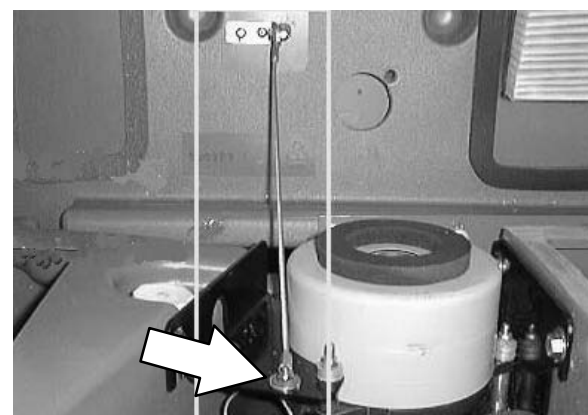

9. Remove the three hex screws holding the tank cover hinge to the recovery tank.  
Remove the tank cover from the machine.

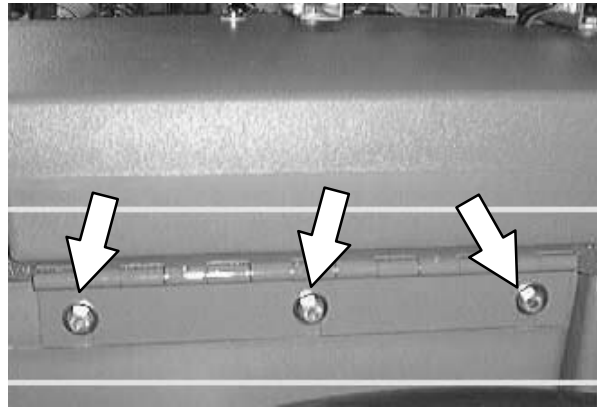

10. Remove the three hex screws holding the vacuum fan assembly to the solution and recovery tanks. Lift the vacuum fan up and disconnect the electrical plug from the main harness. remove the vacuum fan from the machine.

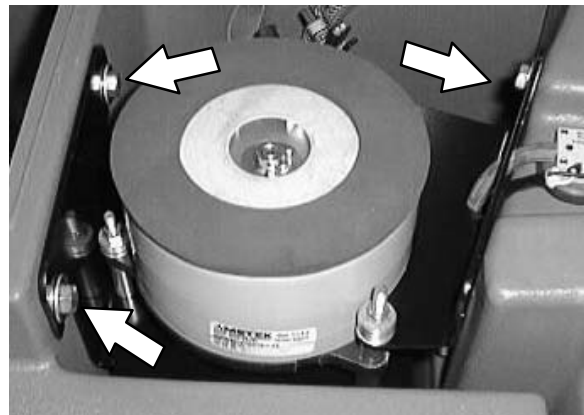

11. Remove the squeegee vacuum hose from the recovery tank.

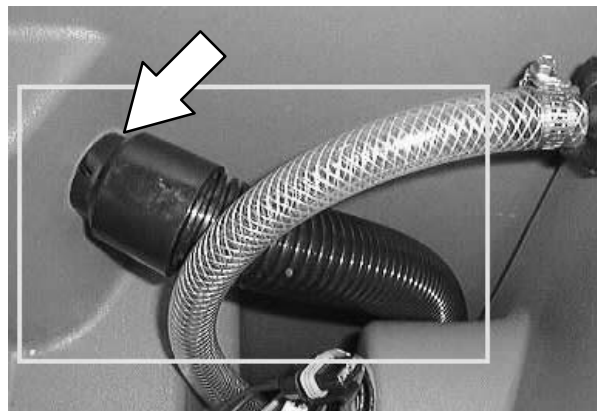

12. Disconnect the recovery tank level switch from the main harness.

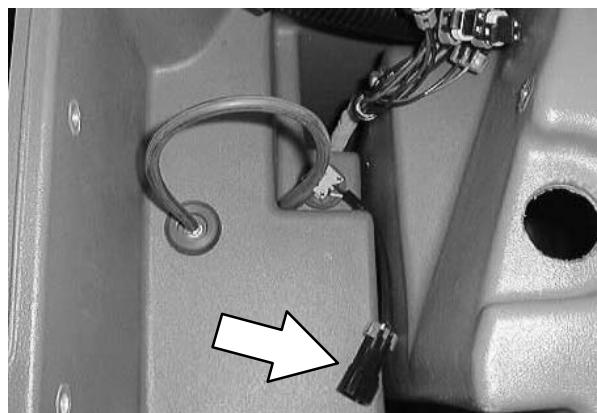

## SCRUBBING

13. If the machine is equipped with the ES option--remove the check valve and hose from the top of the solution tank.

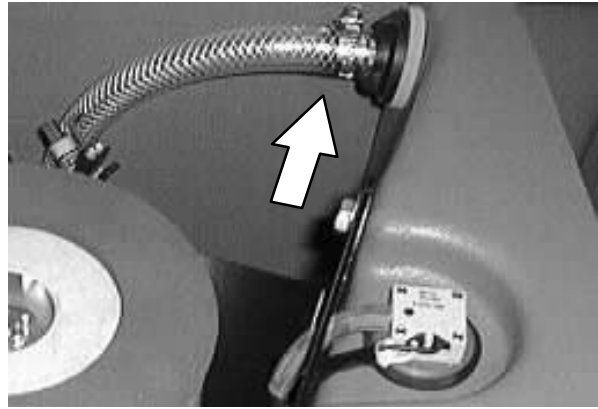

14. Remove the hex screws holding the "L" bracket to the solution and recovery tanks.

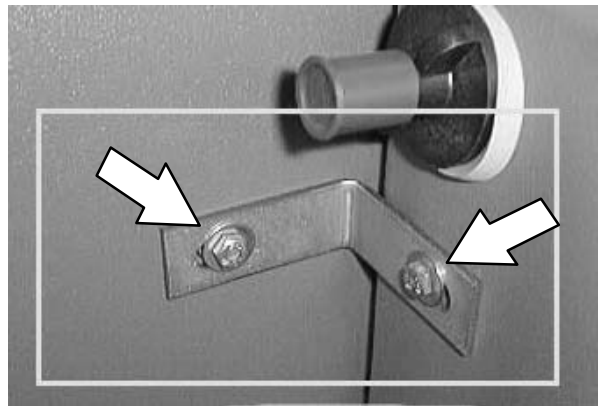

15. Remove both drain hoses from the tanks.

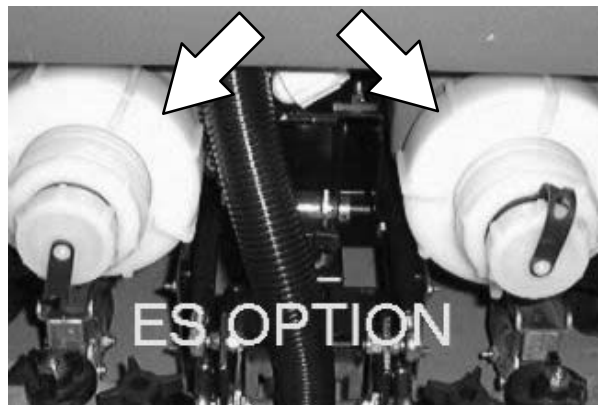

16. Remove the hardware holding the drip tray to the back of the tanks. Remove the drip tray from the machine.

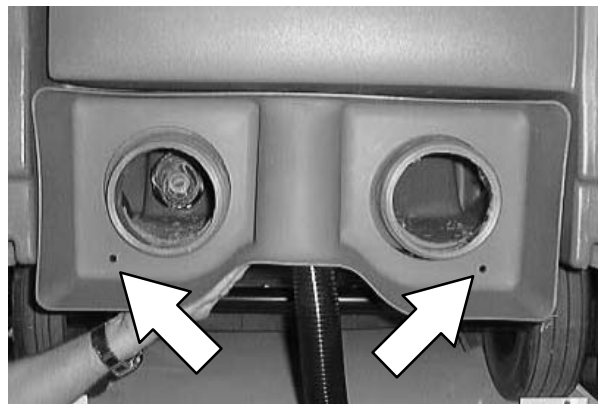



17. Pull the recovery tank up and out of the machine frame.



## SCRUBBING

### TO INSTALL RECOVERY TANK

**FOR SAFETY: Before Leaving Or Servicing Machine; Stop On Level Surface, Set Parking Brake.**

1. Position the recovery tank on the right side edge of the machine frame.

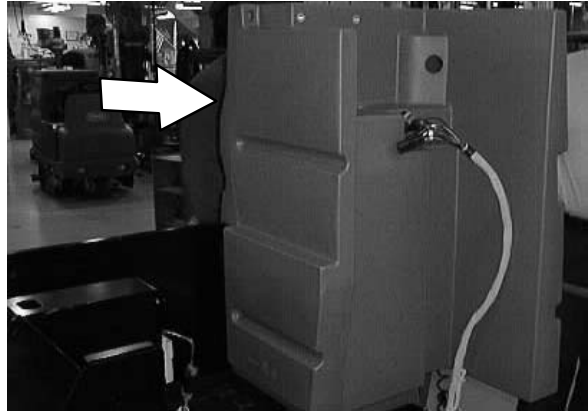

2. Drop the recovery tank down in place. *Be careful to route the electrical harness properly.* Reinstall the three hex screws holding the recovery tank to the machine frame. Tighten the screws to 18 – 24 Nm (15 – 20 ft lb).

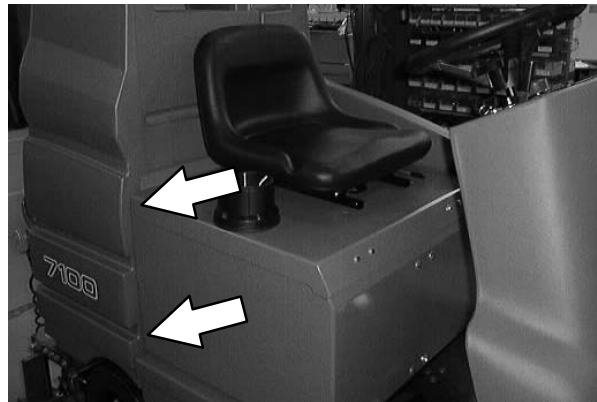

3. Reinstall the “L” bracket to the solution and recovery tanks. Tighten the screws to 18 – 24 Nm (15 – 20 ft lb).

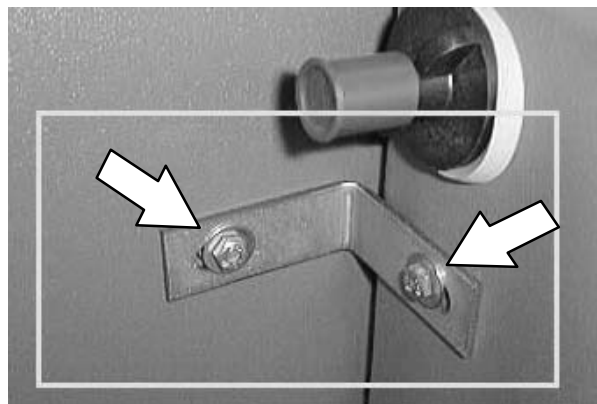

4. Reinstall the check valve and hose in the solution tank.

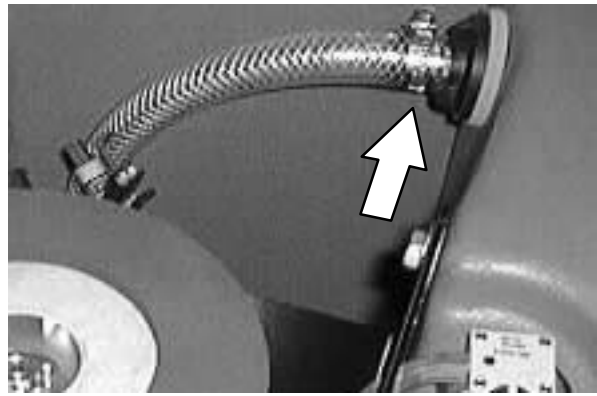

5. Reconnect the recovery tank level switch to the main harness.

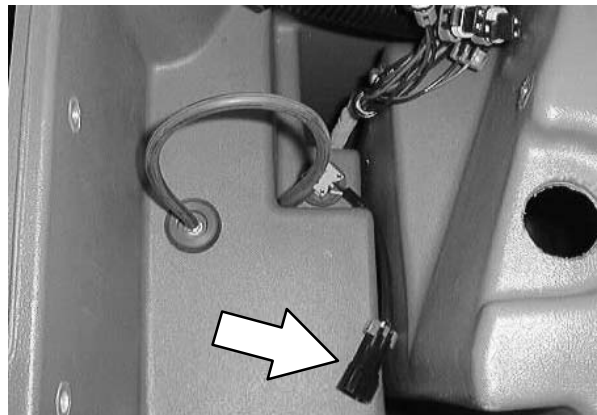

6. Reinstall the squeegee vacuum hose into the recovery tank.

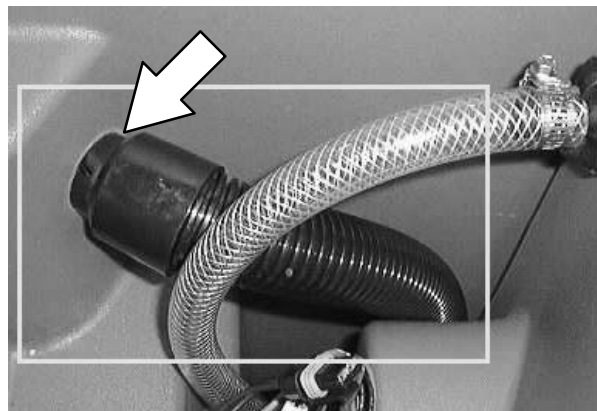

7. Reinstall the vacuum fan assembly. Connect the vacuum fan to the main harness before installing the hardware. Tighten the three hex screws to 18 – 24 Nm (15 – 20 ft lb).

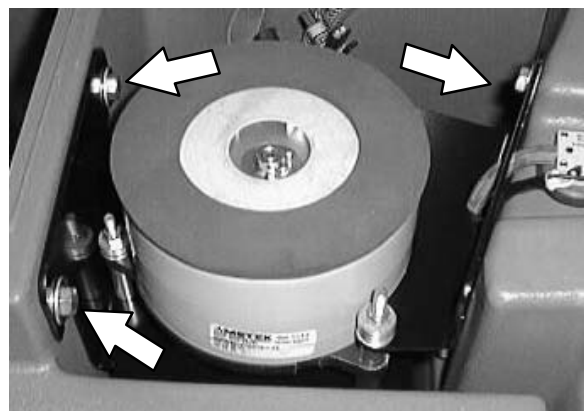

## SCRUBBING

8. Reinstall the tank cover hinge to the recovery tank. Reinstall the three hex screws and tighten to 18 – 24 Nm (15 – 20 ft lb).

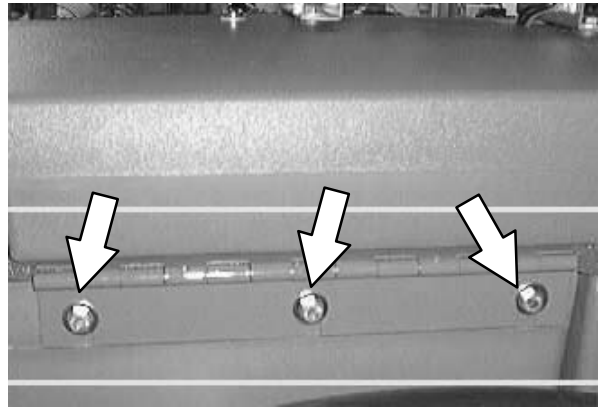

9. Reinstall the cover cable where it attaches to the vacuum fan mount plate. Reinstall the hex screw and tighten to 18 – 24 Nm (15 – 20 ft lb).

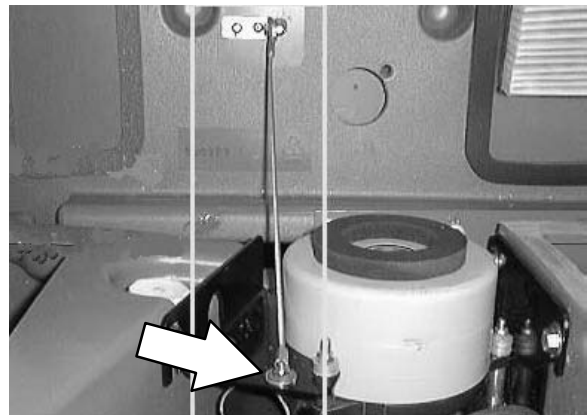

10. Close the tank cover and engage the cover latches.

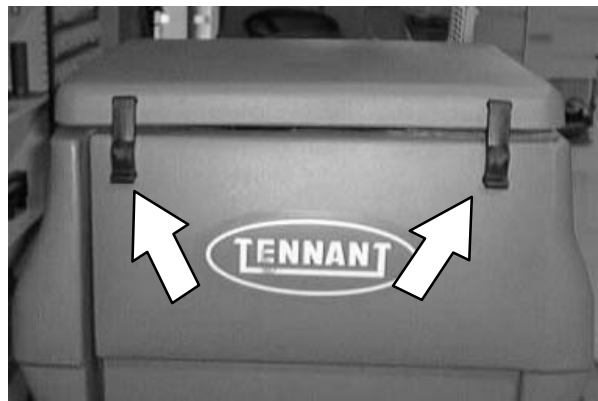

11. Push the right, rear battery backward in the battery tray.

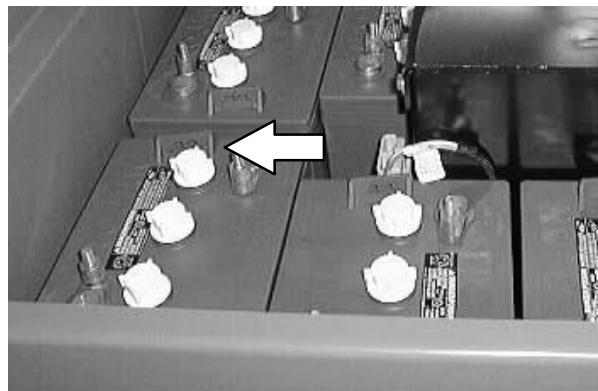

12. Reinstall the battery in the right, middle space in the battery tray. Reconnect the two battery cables.

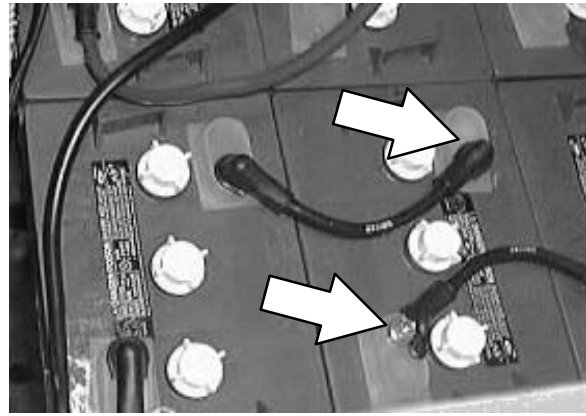

13. Reconnect the battery connector.

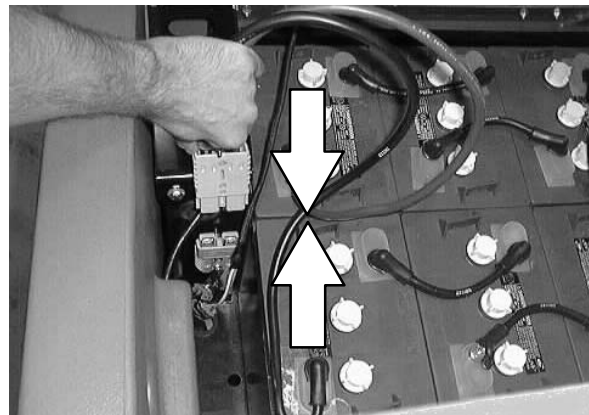

14. Close the seat support.



15. Reinstall the drip tray. Tighten the two hex screws to 18 – 24 Nm (15 – 20 ft lb).

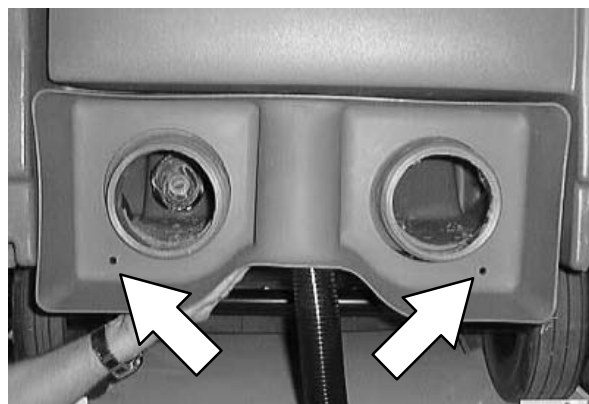

## SCRUBBING

16. Replace both drain hoses in the tanks.

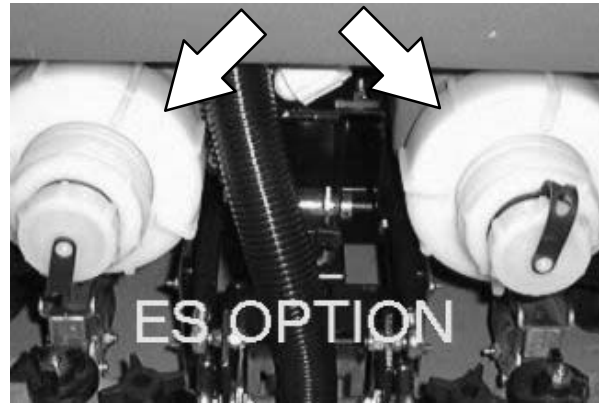

17. Start the machine. Fill the recovery tank with water and check the hose connections for leaks.



**SCRUB HEAD**

The model 7100 can be equipped with either a cylindrical or a disc style scrub head. The scrub head houses the scrub brushes and their drive mechanisms.

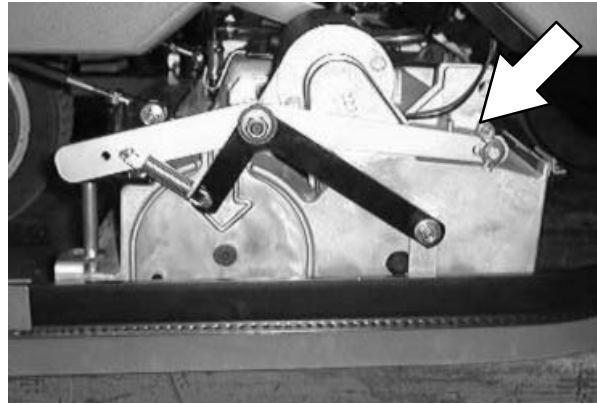

The scrub head adjustments are factory set and should not be changed unless scrub head parts are damaged or replaced.

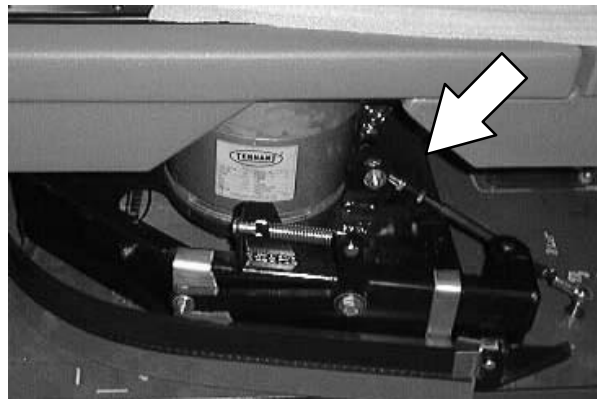

The scrub head also includes floor skirts to control water spray. These skirts can be adjusted and need to be replaced if worn or damaged.

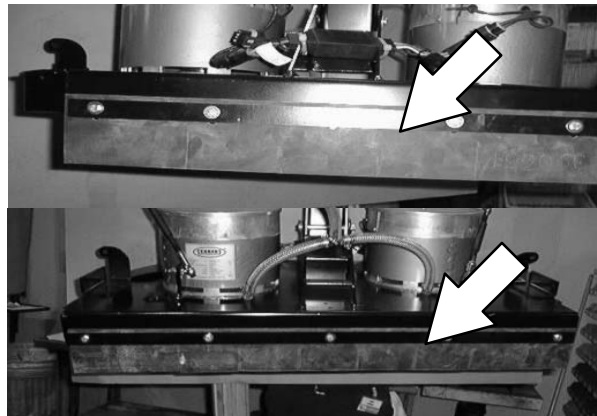

## SCRUBBING

### SCRUB HEAD LINKS

The scrub head links attach the scrub head frame to the machine frame. The two scrub head links allow the scrub head to follow the contour of the floor. The links have a pivot point on each end. The links need no regular lubrication.

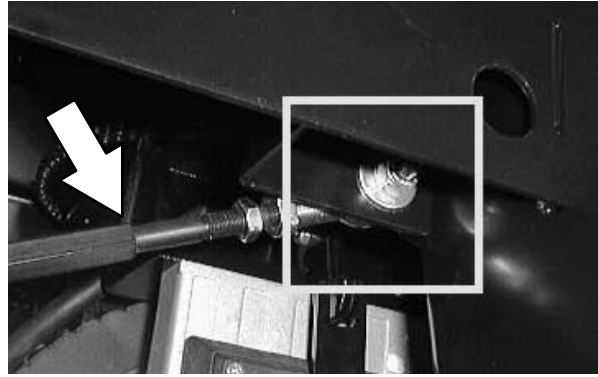



**TO REPLACE SCRUB HEAD LINKS**

1. Start the machine and lower the scrub head to the floor. Shut off the key.

**FOR SAFETY: Before Leaving Or Servicing Machine; Stop On Level Surface, Set Parking Brake.**



2. Go under the machine on each side and remove the nyloc nut holding the scrub head links to the machine frame and scrub head frame. Remove the scrub head links from the machine.

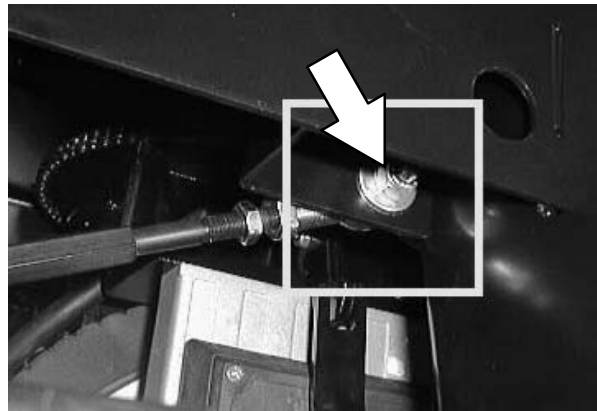

3. The measurement for the new scrub head links should be **11.25 inches** from the center of the front ball joint to the center of the rear balljoint.

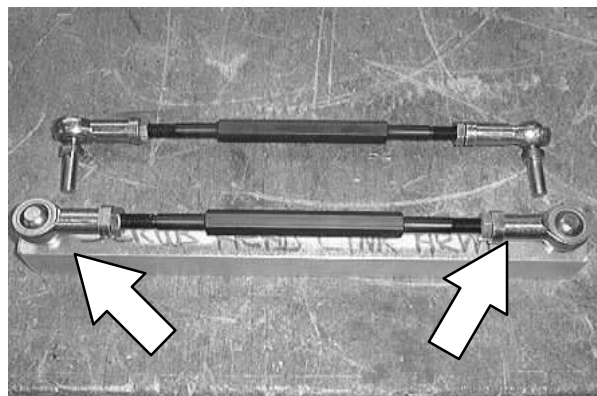

4. Install the new scrub head links on the machine with the ball joints facing the inside of the machine frame. Firmly tighten the four nyloc nuts.

**NOTE:** Use the **front** frame hole for the **cylindrical** scrub head and the **rear** frame mount hole for the **disc** scrub head.

5. Start the machine and raise the scrub head. Check the scrub head links for proper operation.

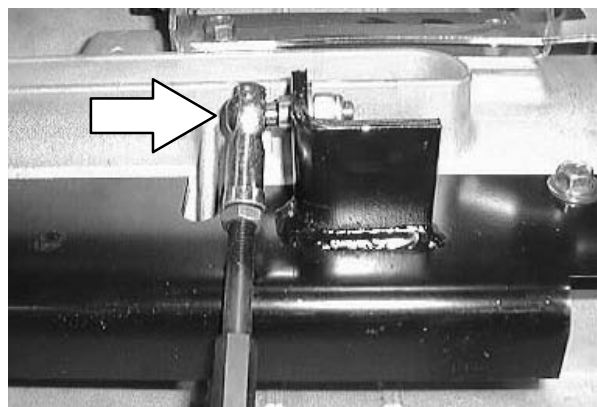

## SCRUBBING

### TO REMOVE DISC SCRUB HEAD

1. Start the machine and lower the scrub head to the floor. Shut off the key.

**FOR SAFETY: Before Leaving Or Servicing Machine; Stop On Level Surface, Set Parking Brake.**



2. Disconnect the water line leading from the shut-off valve to the scrub head.

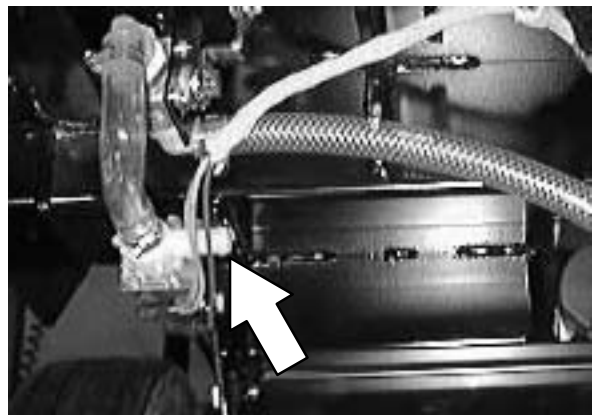

3. Disconnect the scrub brush motors shunt from the main electrical harness. *Mark the connectors for proper re-assembly.*

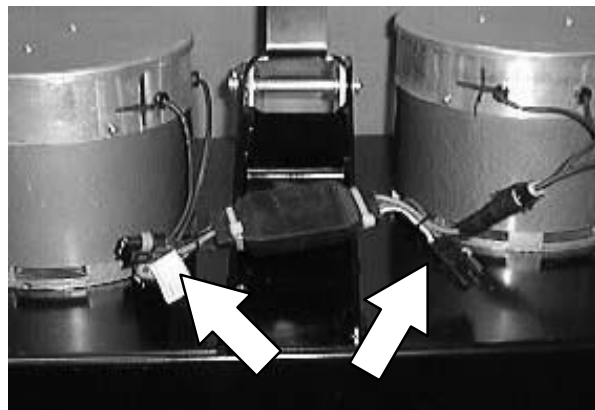

4. Remove the cotter pin and clevis pin from the scrub head lift mechanism where it attaches to the frame and actuator.

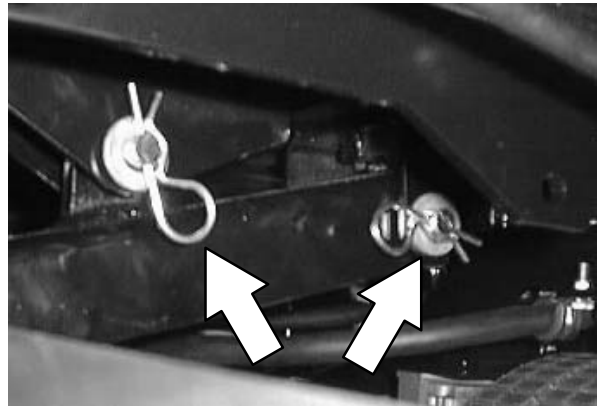

5. Remove the nyloc nut holding the ball joint to the mount bracket on the scrub head. Do this on both sides of the scrub head.

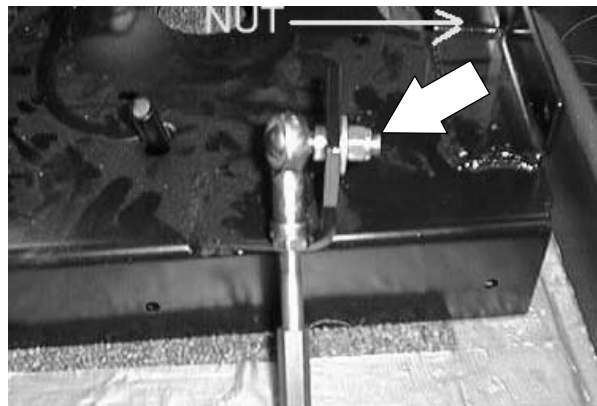

6. Jack up the front of the machine far enough to slide the scrub head out. Install jack stands under the machine frame.

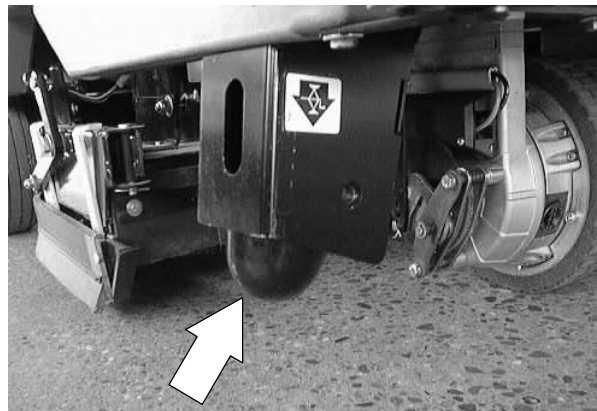

7. The scrub head can now be pulled out from under the machine frame.

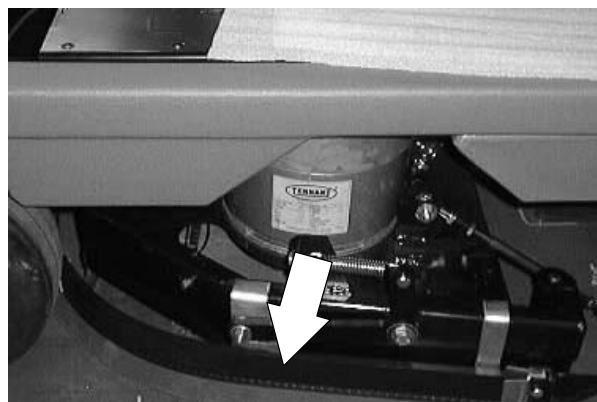

## SCRUBBING

### TO INSTALL DISC SCRUB HEAD

**FOR SAFETY: Before Leaving Or Servicing Machine; Stop On Level Surface, Set Parking Brake.**

1. Slide the scrub head under the machine frame with the scrub head link mount holes facing the front.

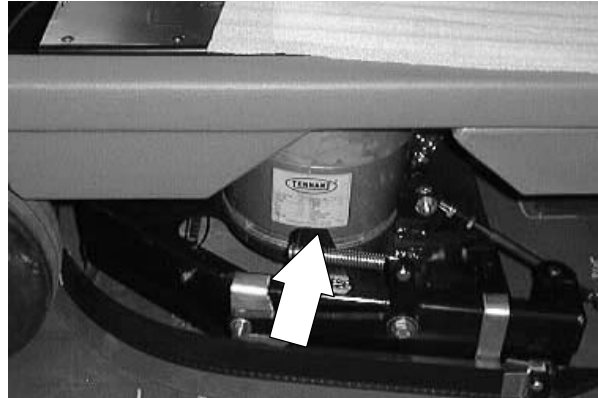

2. Install the ball joint on the end of the scrub head link into the mount hole on the scrub head. The ball joint should be positioned so it is facing the inside of the machine frame. Do this on both sides of the machine.

*NOTE: The measurement for the scrub head links should be **11.25 inches** from the center of the front ball joint to the center of the rear balljoint.*

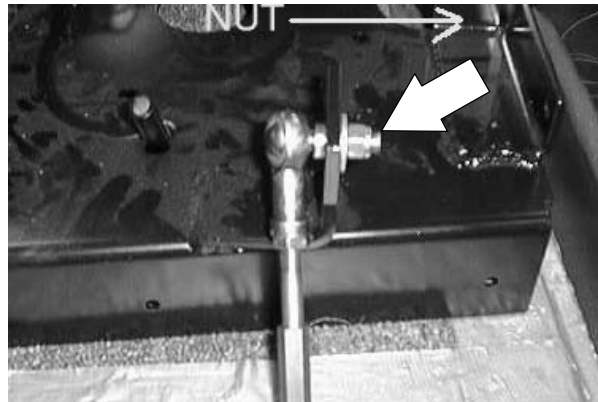

3. Position the scrub head as close as possible to the center. Remove the jack stands and lower the machine until the clevis pins can be reinstalled in the front of the scrub head lift bracket and the bottom of the lift actuator.

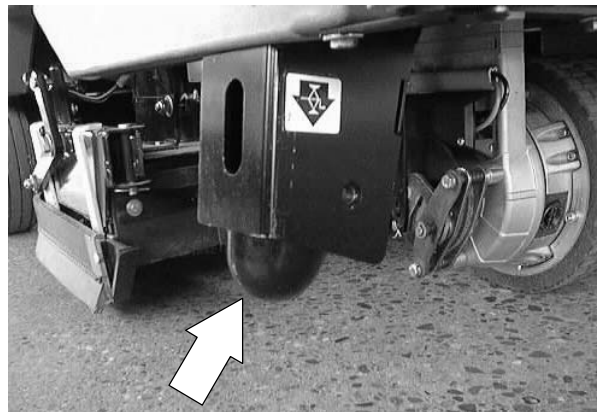

4. Reinstall the clevis pins in the front of the scrub head lift bracket and the bottom of the lift actuator.

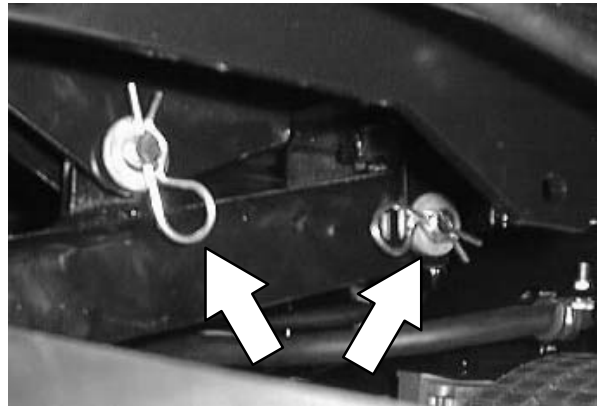

5. Reconnect the brush drive motors to the main electrical harness.

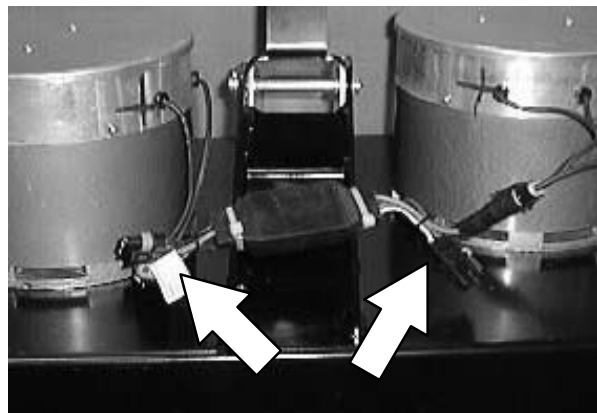

6. Reconnect the water line to the scrub head

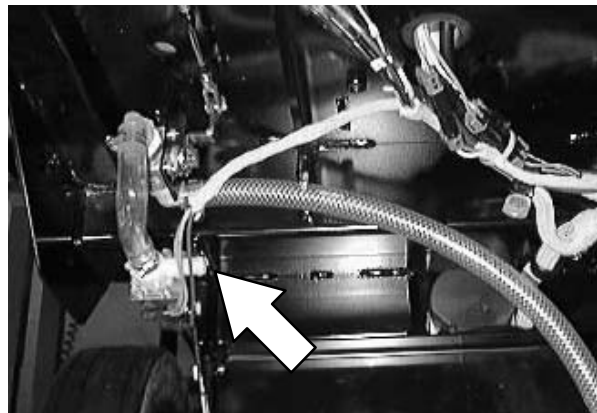

7. Start the machine and raise the scrub head. Operate the machine and check the scrub head for proper operation. Check the scrub brushes for proper rotation (*the brushes should rotate toward each other at the front of the scrub head*).



## SCRUBBING

### TO REMOVE CYLINDRICAL SCRUB HEAD

1. Start the machine and lower the scrub head to the floor. Shut off the key.

**FOR SAFETY: Before Leaving Or Servicing Machine; Stop On Level Surface, Set Parking Brake.**



2. Disconnect the water line leading from the shut off valve to the scrub head.

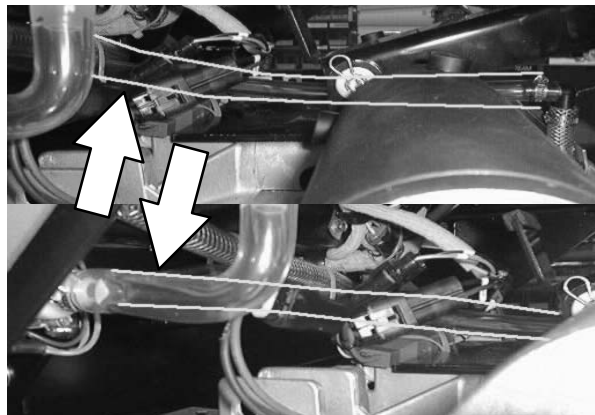

3. Disconnect the two scrub brush motors from the main electrical harness. Mark the connectors for proper re-assembly.



4. Remove the cotter pin and clevis pin from the scrub head lift mechanism where it attaches to the scrub head.

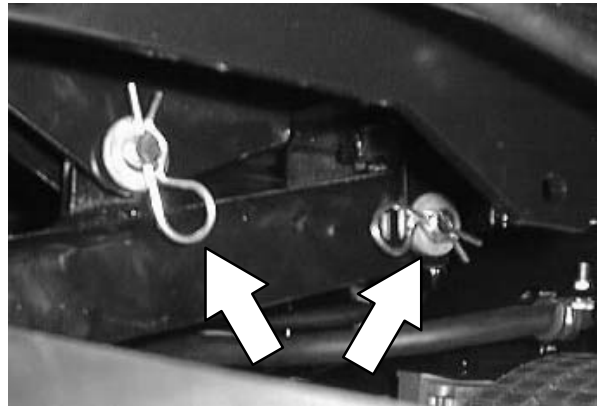

5. Remove the nyloc nut holding the ball joint to the mount bracket on the scrub head. Do this on both sides of the machine.

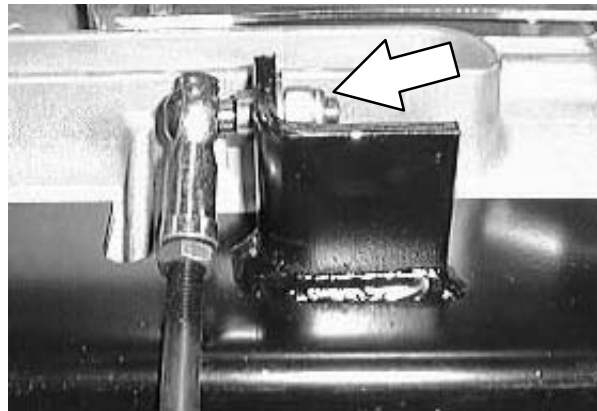

6. Jack up the front of the machine far enough to slide the scrub head out. Install jack stands under the machine frame.

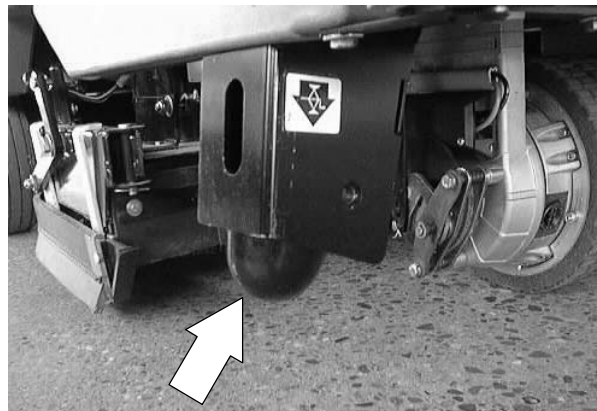

7. The scrub head can now be pulled out from under the machine frame.

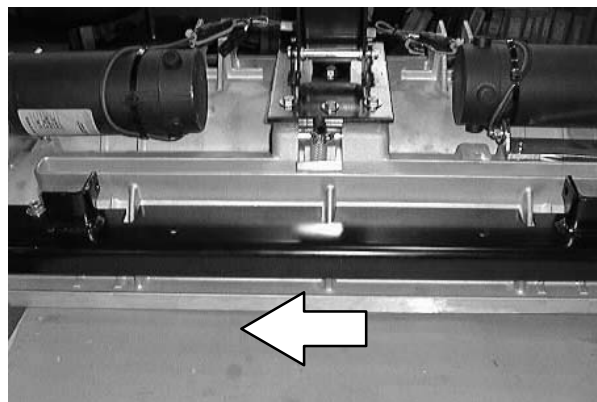

## SCRUBBING

### TO INSTALL CYLINDRICAL SCRUB HEAD

**FOR SAFETY: Before Leaving Or Servicing Machine; Stop On Level Surface, Set Parking Brake.**

1. Slide the scrub head under the machine frame with the scrub head link mount holes facing the front.

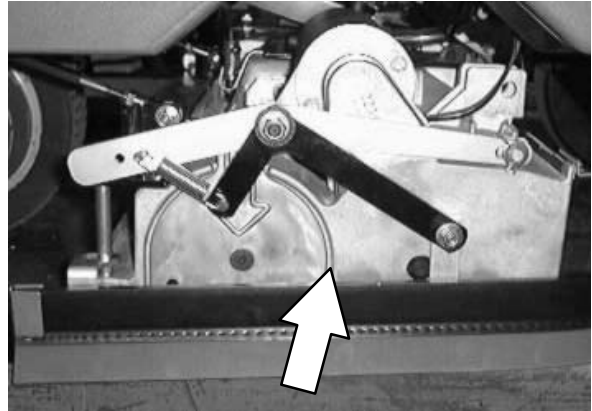

2. Install the ball joint on the end of the scrub head link into the mount hole on the scrub head. The ball joint should be positioned so it is facing the inside of the machine frame. Do this on both sides of the machine.

*NOTE: The measurement for the scrub head links should be **11.25 inches** from the center of the front ball joint to the center of the rear balljoint.*

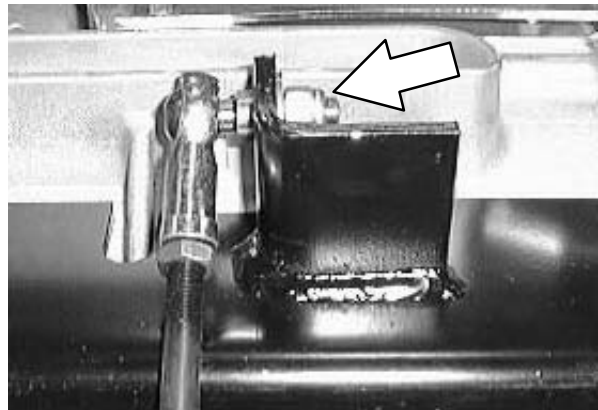

3. Position the scrub head as close as possible to the center. Remove the jack stands and lower the machine until the clevis pins can be reinstalled in the front of the scrub head lift bracket and the bottom of the lift actuator. Reinstall the clevis pin and cotter pin.

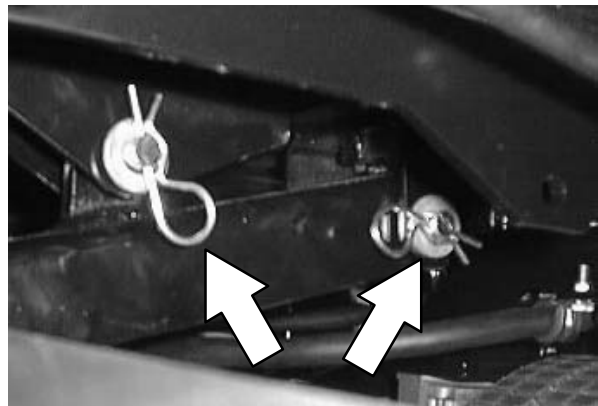



4. Reconnect the brush drive motors to the main electrical harness.

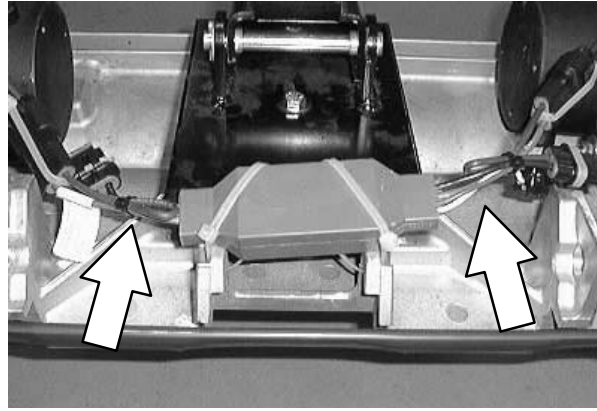

5. Reconnect the water line to the scrub head

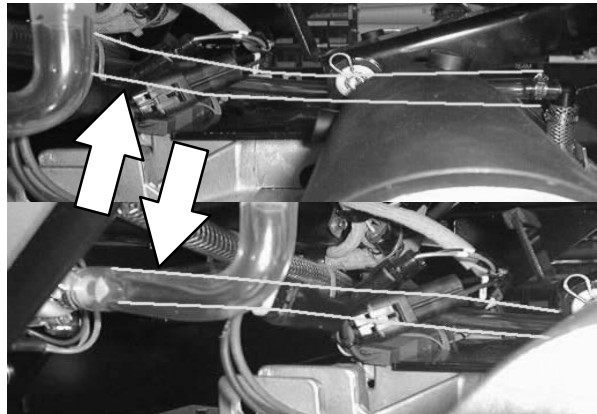

6. Start the machine and raise the scrub head. Operate the machine and check the scrub head for proper operation. Check the scrub brushes for pattern and proper rotation (*the brushes should rotate away from each other at the top of the scrub head*). See TO CHECK AND ADJUST CYLINDRICAL BRUSH PATTERN instructions.

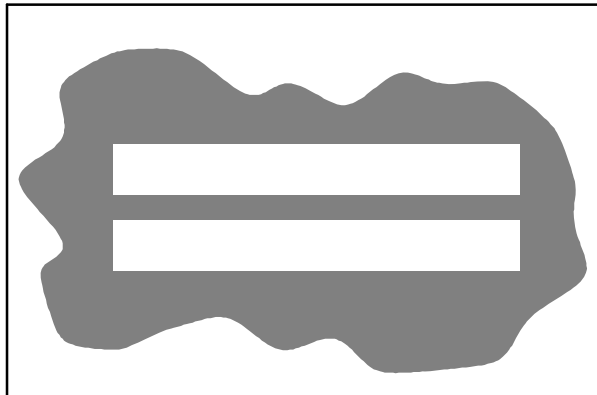

## DISC SCRUB HEAD SKIRTS

### SCRUB HEAD FLOOR SKIRTS

The scrub head floor skirts control water spray from the brushes. The skirts are located in front and rear of the scrub head. Check these skirts for wear and damage after every 50 hours of operation.

The skirts should clear the floor by 0 to 0.25 in. (0 to 6mm) when the scrub head is down. Check the floor skirt adjustment after every 50 hours of operation.

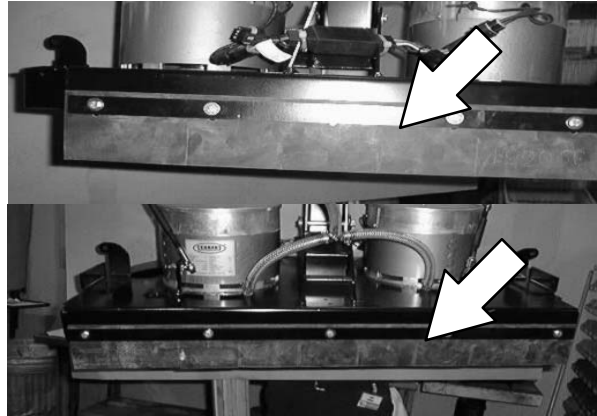

### TO ADJUST DISC SCRUB HEAD SKIRTS

1. Start the machine and lower the scrub head to the floor. Shut off the key.

**FOR SAFETY: Before Leaving Or Servicing Machine; Stop On Level Surface, Set Parking Brake.**



2. Loosen the screws holding the retainer and skirt to the scrub head frame.

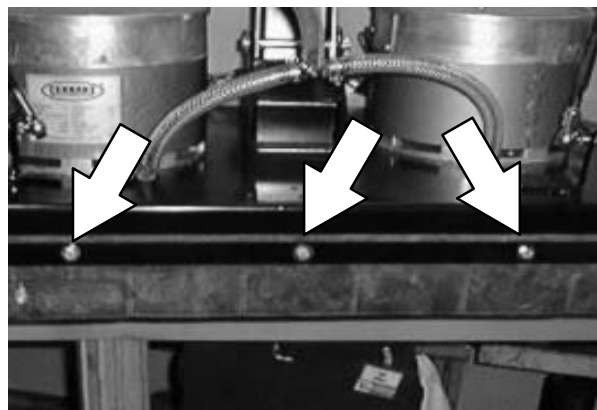

3. Position the up or down as needed to achieve 1/8 to 1/4 inch clearance from the bottom of the skirt to the floor.

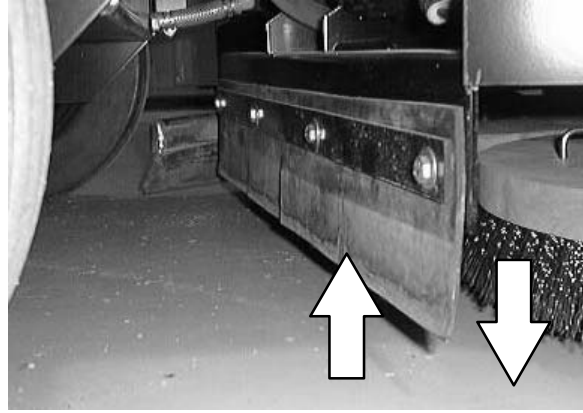

4. Re-tighten the retainer screws. Operate the machine and check the scrub head skirts for proper water spray control.

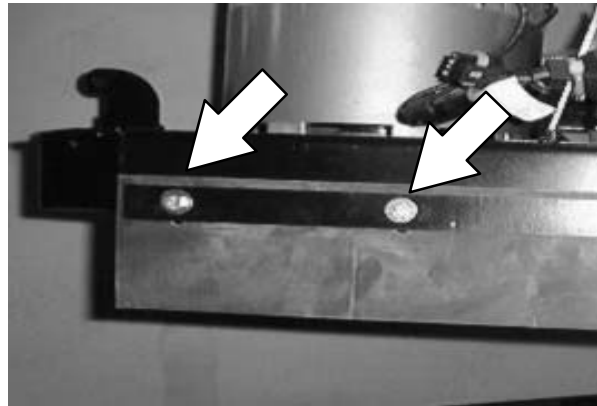

## SCRUBBING

### TO REPLACE DISC SCRUB HEAD SKIRTS

1. Start the machine and lower the scrub head to the floor. Shut off the key.

**FOR SAFETY: Before Leaving Or Servicing Machine; Stop On Level Surface, Set Parking Brake.**



2. Remove the screws holding the retainer and skirt to the scrub head frame. Remove and discard the skirt.

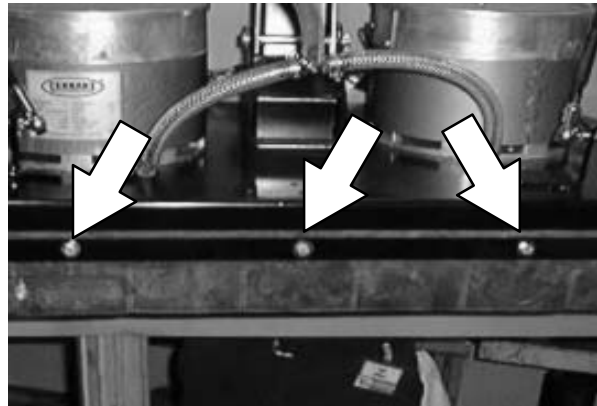

3. Position the new skirt and existing retainer on the scrub head. Adjust the skirt and tighten the retainer screws. See TO ADJUST DISC SCRUB HEAD SKIRTS instructions.

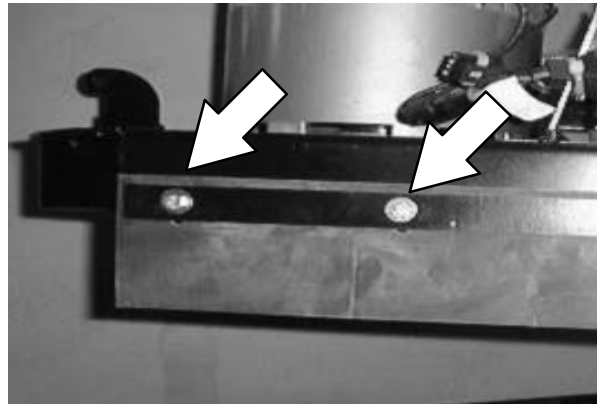

4. Operate the machine and check the scrub head skirts for proper water spray control.

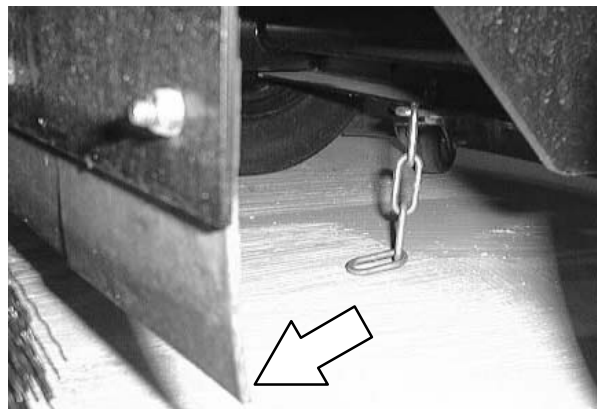

## CYLINDRICAL BRUSH HEAD DEBRIS TRAY

The cylindrical style scrub head is equipped with a rear mounted debris tray. Small debris is picked up by the two cylindrical scrub brushes and deposited in the debris tray located behind the rear scrub brush. The debris tray can be easily removed and emptied.

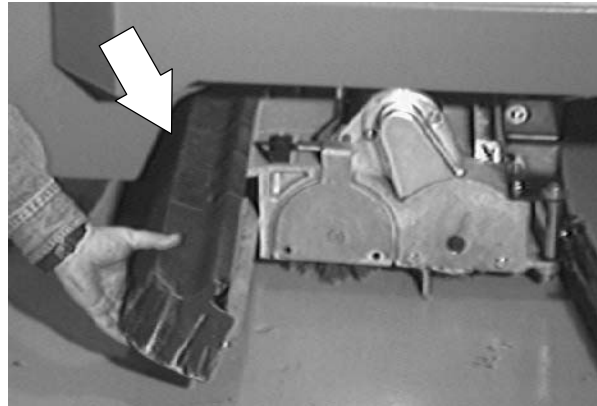

## TO REMOVE DEBRIS TRAY

1. Start the machine and touch the scrub button. Shut off the key when the scrub head is near the floor. *Do not touch the directional pedal.*

**FOR SAFETY: Before Leaving Or Servicing Machine; Stop On Level Surface, Set Parking Brake.**



2. Go to the right side of the machine. Locate the scrub head side squeegee. Pull the hair pin out of the squeegee lock pin.

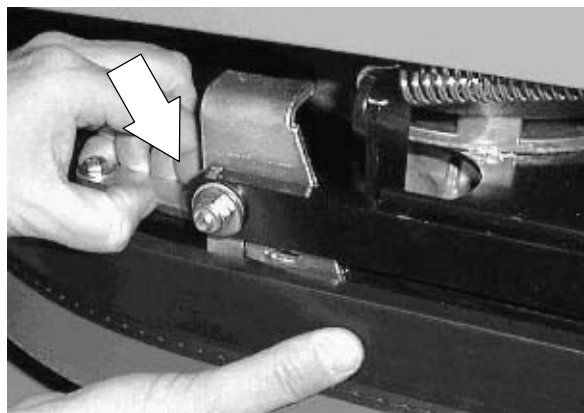

## SCRUBBING

3. Pivot the side squeegee out, away from the scrub head.

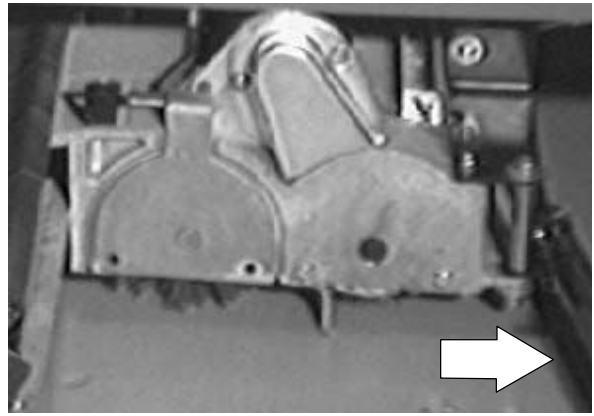

4. Grasp the plastic debris tray and pivot the bottom up, away from the back of the scrub head. Pivot the debris tray far enough to allow the rubber skirt to clear the scrub head.

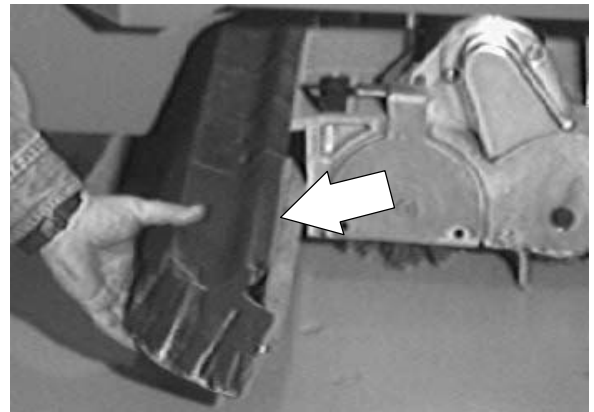

5. Pull the debris tray straight out to the right until it is free of the scrub head lip. Empty the debris tray.

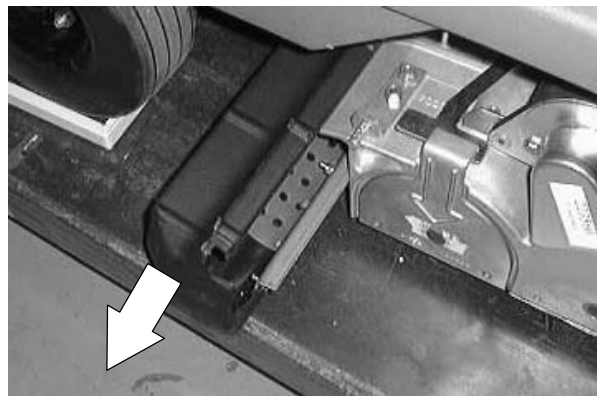

**TO INSTALL DEBRIS TRAY**

1. Lower the scrub head to the floor.

**FOR SAFETY: Before Leaving Or Servicing Machine; Stop On Level Surface, Set Parking Brake.**

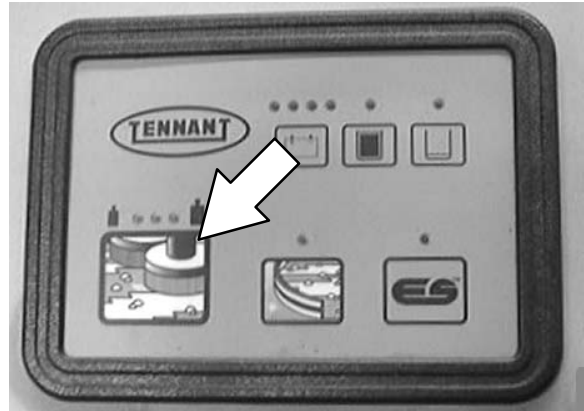

2. Position the debris tray, opening facing forward, on the lip on the back of the scrub head. Push the debris tray in until it stops.

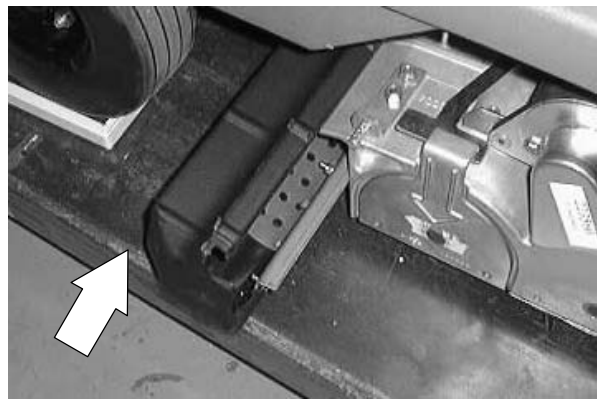

3. Swing the right hand side squeegee back to the side of the scrub head. Make sure the lock pin is positioned in the mount hole. Reinstall the hair pin.

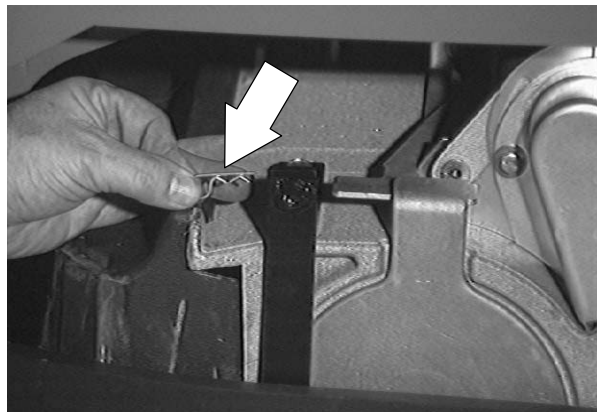

4. Start the machine and raise the scrub head.

## SCRUBBING

### TO REPLACE DEBRIS TRAY SKIRT

1. Remove the debris tray. See TO REMOVE DEBRIS TRAY instructions.

**FOR SAFETY: Before Leaving Or Servicing Machine; Stop On Level Surface, Set Parking Brake.**

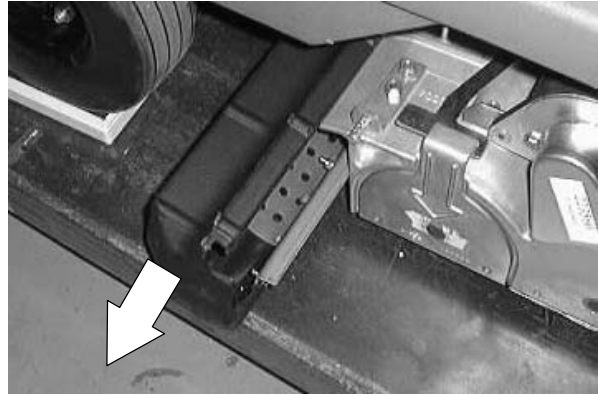

2. Remove the six screws, washers, and nuts holding the debris tray skirt and retainer to the top lip of the tray. Remove the retainer and skirt. Discard the skirt.
3. Position the new debris tray skirt and existing retainer on the top lip of the tray.
4. Reinstall the hardware and hand tighten lightly.

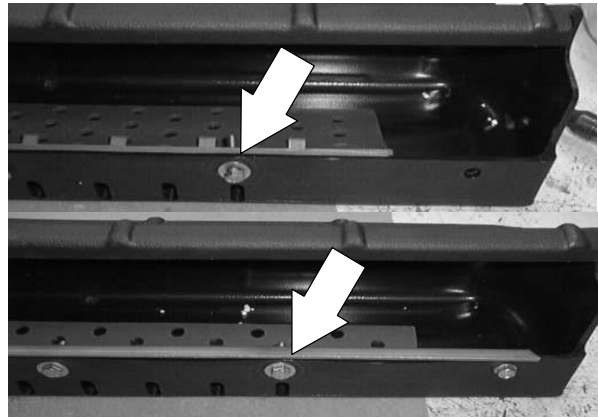

5. Reinstall the debris tray in the machine. See TO INSTALL DEBRIS TRAY instructions.

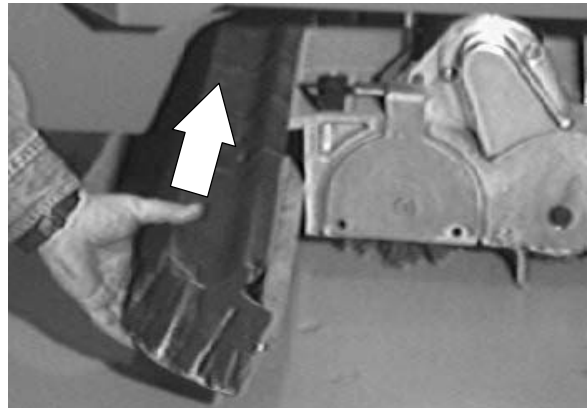



## SCRUB BRUSHES

The machine can be equipped with either *disk* or *cylindrical* scrub brushes. Check scrub brushes daily for wire or string tangled around the brush or brush drive hub. Also check for brush damage and wear.

### DISC SCRUB BRUSHES

The disk brushes should be replaced if a large number of bristles are missing or if bristle length is less than 10 mm (0.38 in).

*NOTE: Replace worn brushes in pairs. Scrubbing with brushes of unequal bristle length will result in diminished scrubbing performance.*

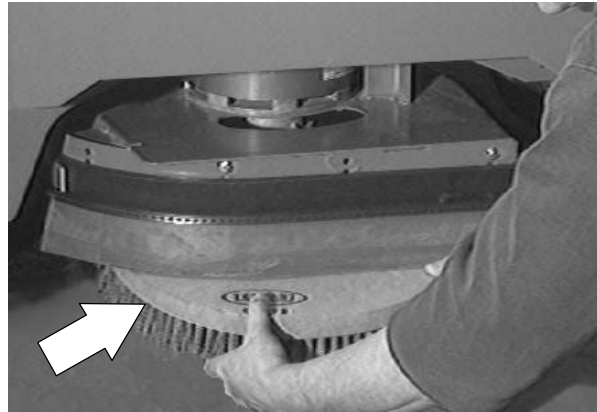

### TO REPLACE DISC SCRUB BRUSHES

1. Make sure the scrub head is in the raised position.

**FOR SAFETY: Before Leaving Or Servicing Machine; Stop On Level Surface, Set Parking Brake.**



2. Turn the brush until you can see the brush spring clip.

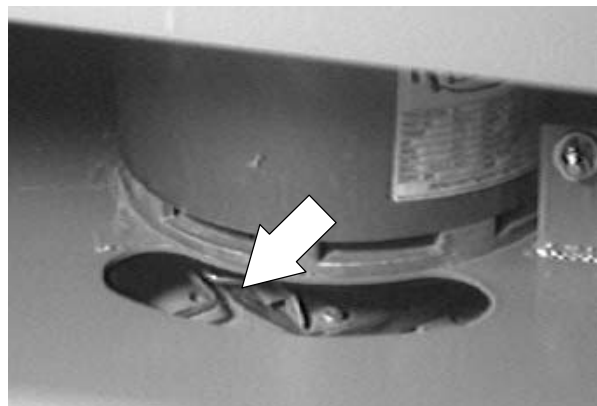

## SCRUBBING

3. Press the brush spring clip together with your thumb and index finger. The brush will drop off of the brush drive hub. Pull the brush out from under the scrub head.

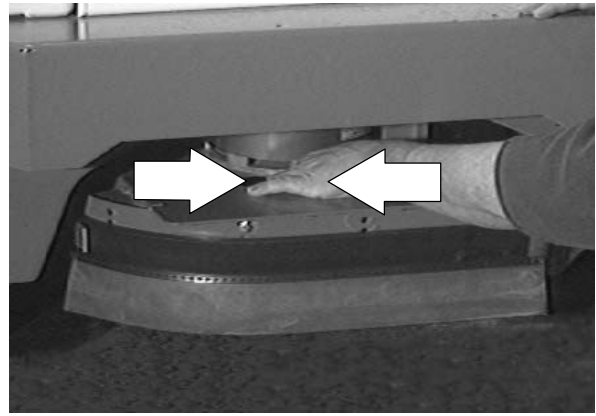

4. Place the new scrub brush on the floor in front of the scrub head. Push the brush under the scrub head.
5. Line up the brush drive socket with the drive plug.

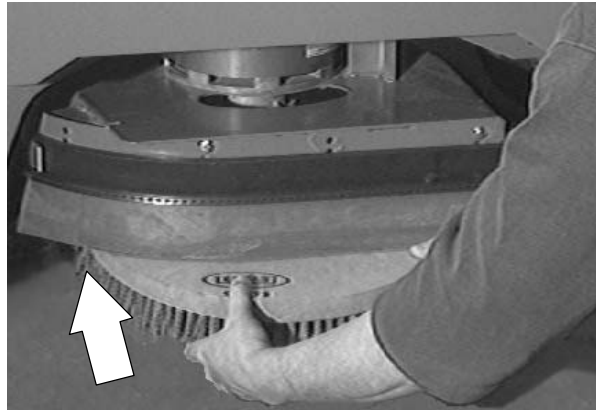

6. While pressing the brush spring clip together with your thumb and index finger, lift the scrub brush onto the drive plug.
7. Check to make sure the brush is securely mounted on the brush drive hub.
8. Repeat for the other brush.

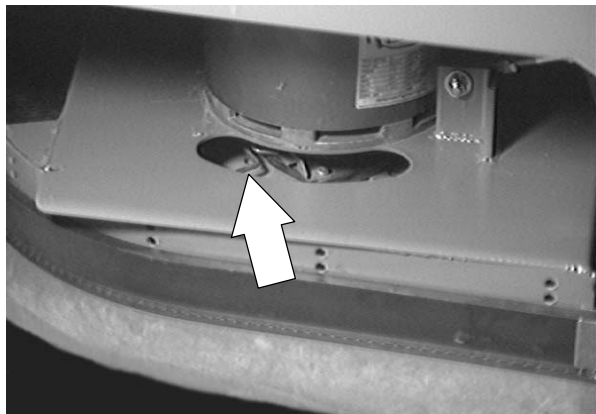

## CYLINDRICAL SCRUB BRUSHES

Check the brush taper and rotate the brushes from front-to-rear every 50 hours of machine operation for maximum brush life and best scrubbing performance.

The cylindrical brushes should be replaced if large amounts of bristles are missing, or if the remaining bristle length is less than 10 mm (0.38 in).

*NOTE: Replace worn brushes in pairs. Scrubbing with brushes of unequal bristle length will result in diminished scrubbing performance.*

*NOTE: Fill the solution tank before checking or adjusting the brush pattern.*

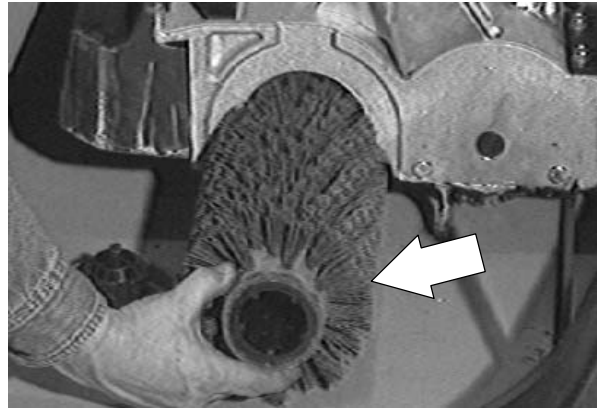

## TO REPLACE CYLINDRICAL SCRUB BRUSHES

1. Press the scrubbing switch. When the scrub head is approximately 25 mm (1 in) from the floor, turn the machine power off.

**FOR SAFETY: Before Leaving Or Servicing Machine; Stop On Level Surface, Set Parking Brake.**



2. Remove the cotter pin that holds the side squeegee in place. Swing the squeegee away from the scrub head.

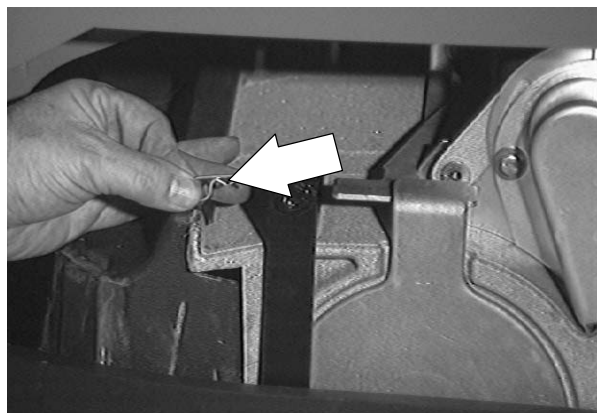

## SCRUBBING

3. Push downward on the mounting spring and idler door until the top of the door releases from the scrub head. Pull the bottom of the door outward, then pull the idler door and idler plug off of the brush.

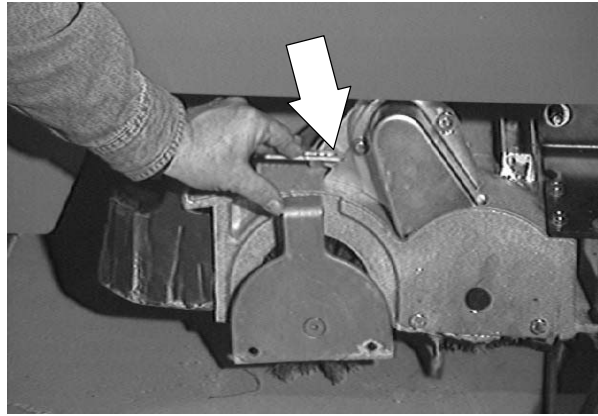

4. Pull the old brush out of the scrub head.

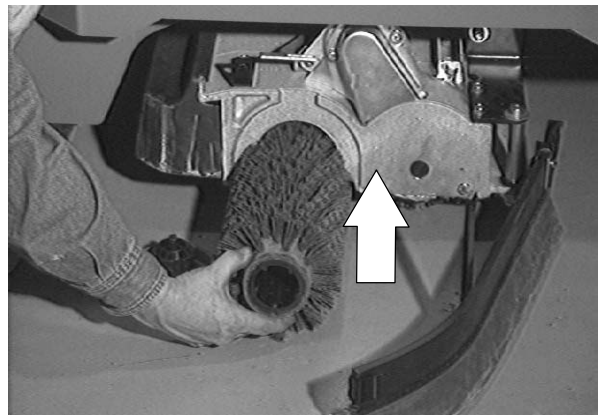

5. Position the brush with the *double row end towards you*. Guide the new brush onto the drive hub.

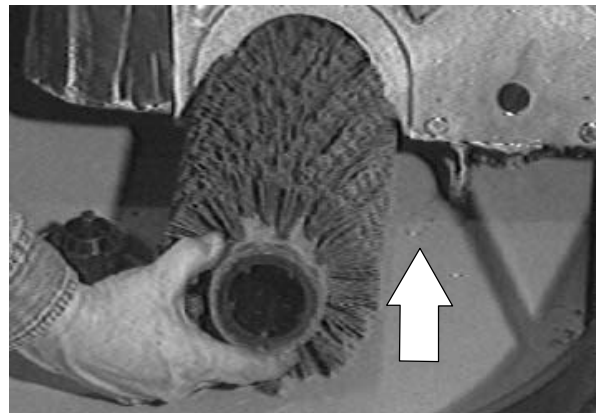

6. Insert the Idler plug (on the inside of the idler door), into the brush.

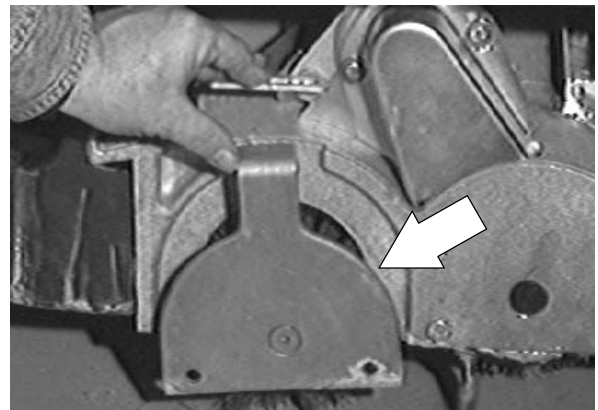

7. Push down on the door to catch the door in the scrub head, then pull up on the door to latch it into the spring.

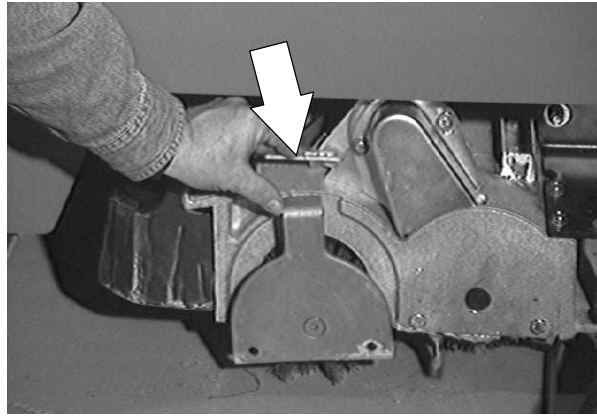

8. Swing the right hand side squeegee back to the side of the scrub head. Make sure the lock pin is positioned in the mount hole. Reinstall the hair pin.

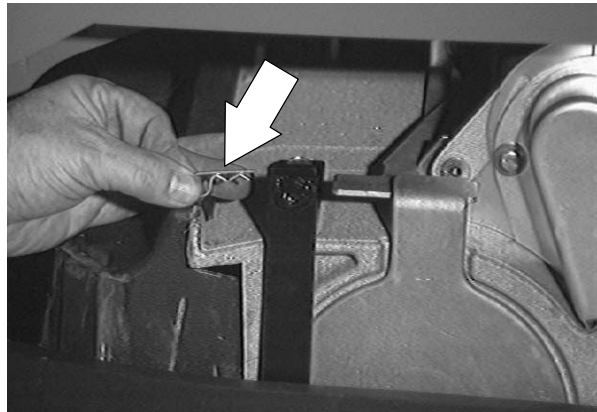

9. Start the machine and raise the scrub head.

10. Repeat for the other brush on the other side of the scrub head.

~~NOTE: Each side of the scrub head is stamped with a letter. The idler door of that side of the scrub head is stamped with the same letter. Make sure the letter on the door matches the letter on the scrub head when replacing the doors.~~



## SCRUBBING

### TO CHECK AND ADJUST CYLINDRICAL BRUSH PATTERN

1. Apply chalk (or another material that will not easily blow away), to a smooth, level section of the floor.
2. Set the parking brake.

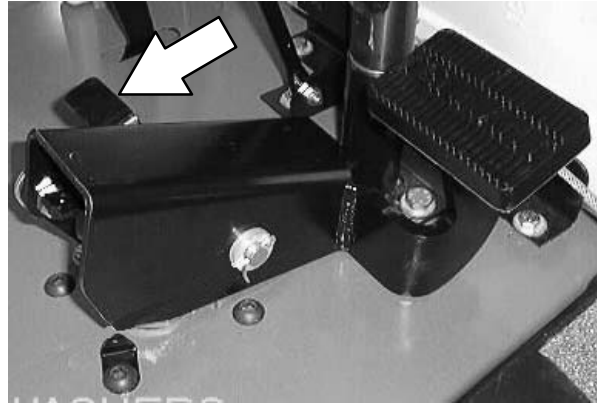

3. Lower the scrub head in the chalked area. Allow the machine to scrub in the same place for 15 to 20 seconds.

*NOTE: If chalk or other material is not available, allow the brushes to spin on the floor for two minutes. A polish mark will remain on the floor.*



4. Raise the scrub head and move the machine away from the chalked area. Turn the machine power off.



5. Observe the shape of the brush patterns. If the brush patterns have parallel sides, the brushes do not need adjustment.

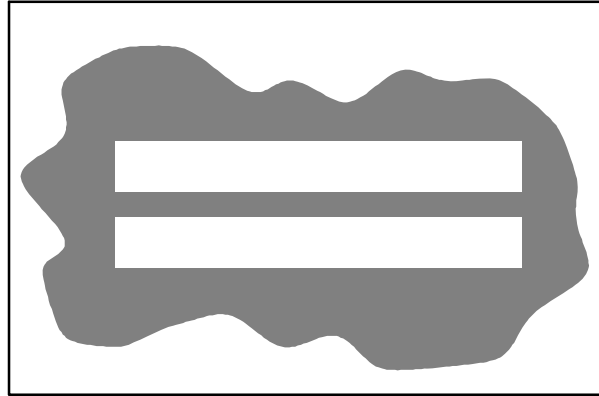

10355

- If one, or both of the brush patterns are tapered, the brushes need adjustment to straighten the brush pattern.

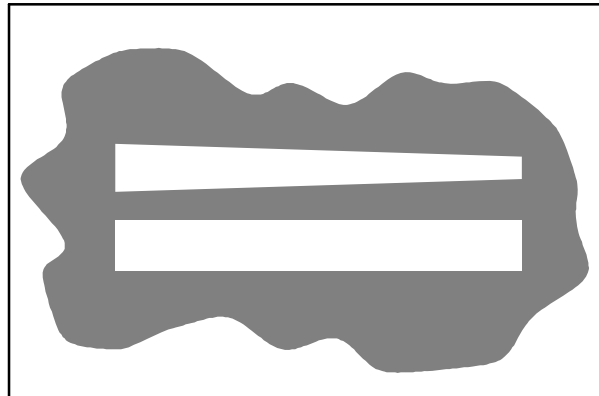

10356

1. To adjust brush taper, push downward on the mounting spring and idler door until the top of the door releases from the scrub head. Pull the bottom of the door outward, then pull the idler door and idler plug off of the brush.

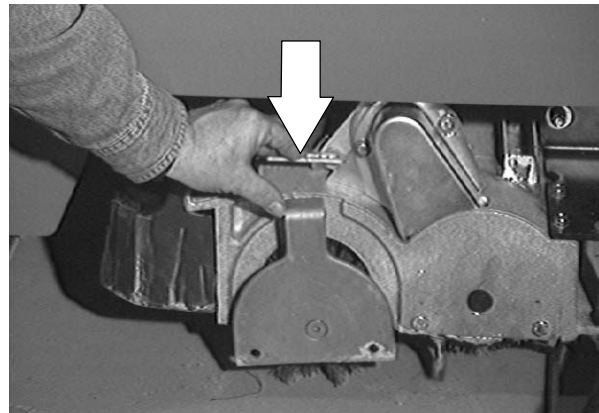

2. While holding the flat end of the idler shaft with a wrench, loosen the mounting screw on the outside of the idler door.

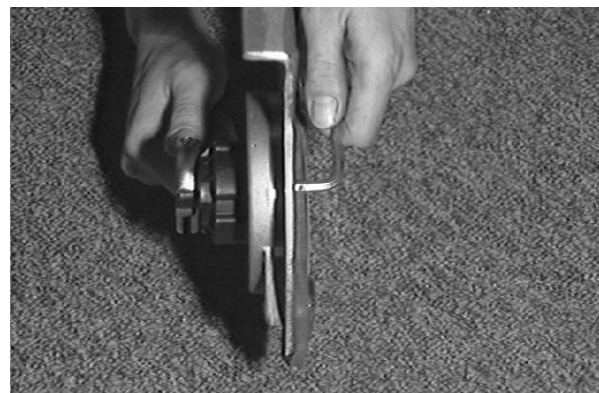

## SCRUBBING

3. Turn the idler shaft to raise or lower the end of the brush as needed to straighten the brush pattern. Tighten the mounting screw.
4. Check the brush patterns again and readjust as necessary until both patterns are the same.

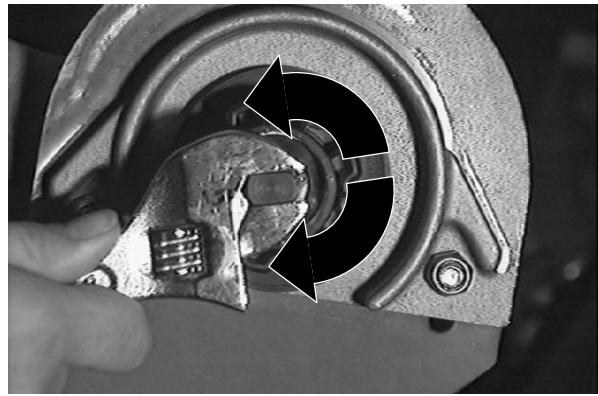

6. If one brush pattern is wider than the other, the scrub head needs to be leveled.

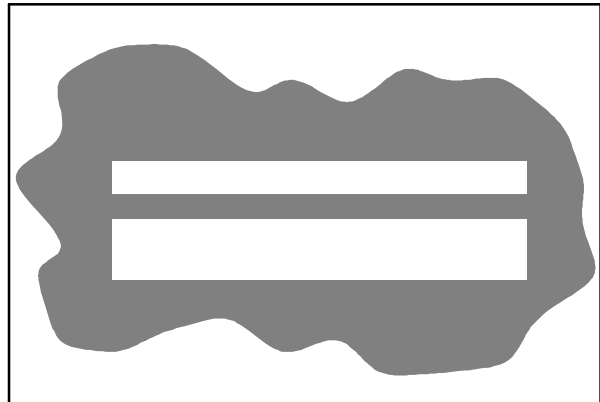

Level the scrub head by turning the scrub head links. Both scrub head links should be adjusted equally.

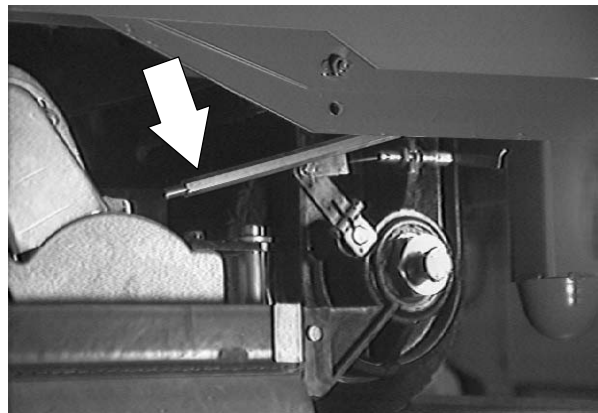

Check the brush patterns again and readjust as necessary until both patterns are the same.

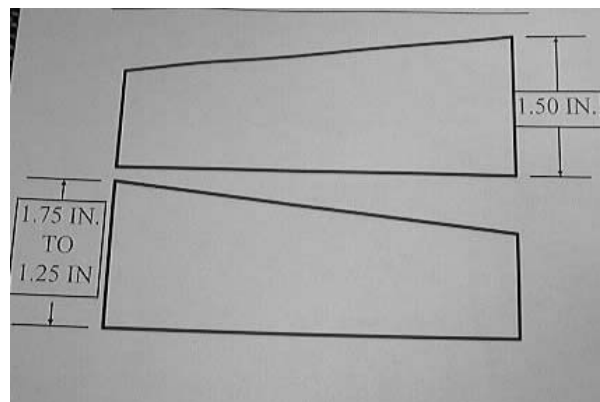



## CYLINDRICAL BRUSH DRIVE BELT

The two brush drive belts are located on the cylindrical brush scrub head. The belts drive the cylindrical brushes. Proper belt tension is a 3 mm (0.1 in) deflection from a force of 1.1 to 1.2 kg (2.5 to 2.7 lb) at the belt midpoint.

Check and adjust the belt tension every 100 hours of operation.

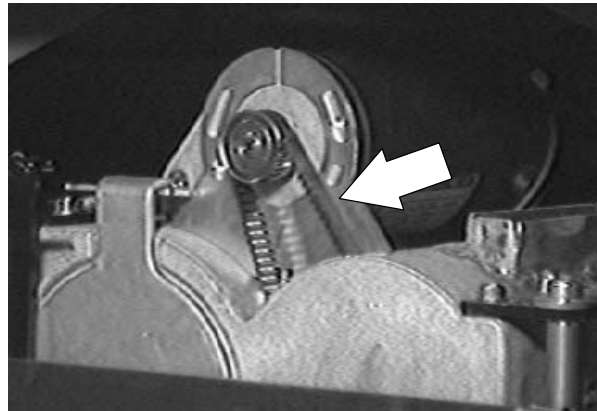

## TO REPLACE BRUSH DRIVE BELT

1. Start the machine and lower the scrub head near the floor. Shut off the key.

**FOR SAFETY: Before Leaving Or Servicing Machine; Stop On Level Surface, Set Parking Brake.**



2. Remove the scrub brushes. See TO REPLACE CYLINDRICAL SCRUB BRUSHES instructions.

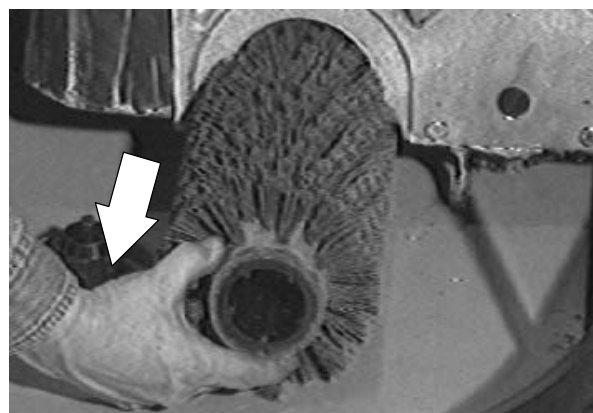

## SCRUBBING

3. Remove the two screws holding the belt cover to the scrub brush motor. Remove the belt cover from the scrub head.

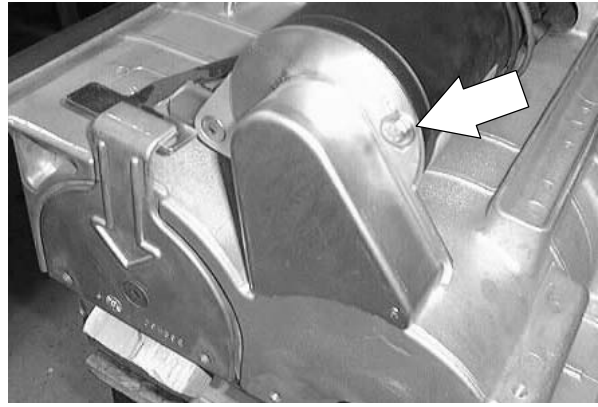

4. Loosen the two pivot bolts on the bottom of the brush motor.

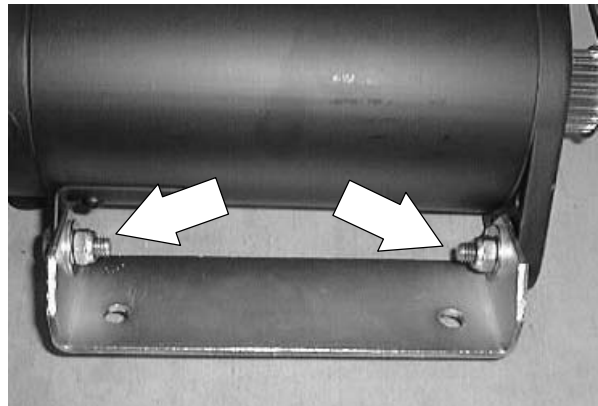

5. Loosen the belt tension bolt under the brush motor. Turn the bolt down far enough to allow the belt to be slipped off the motor pulley. Push the drive belt down toward the lower brush drive plug.

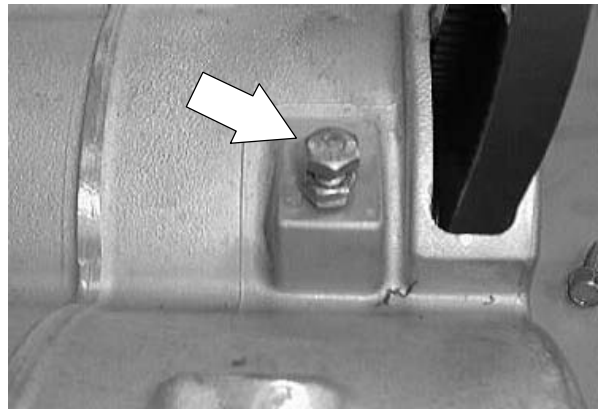

6. Remove the drive plug from the scrub head. Use a wrench on the flats of the hub shaft. Turn the shaft counter-clockwise.

*NOTE: Make sure the scrub head is slightly off the floor before attempting to remove the drive plug rubber seal.*

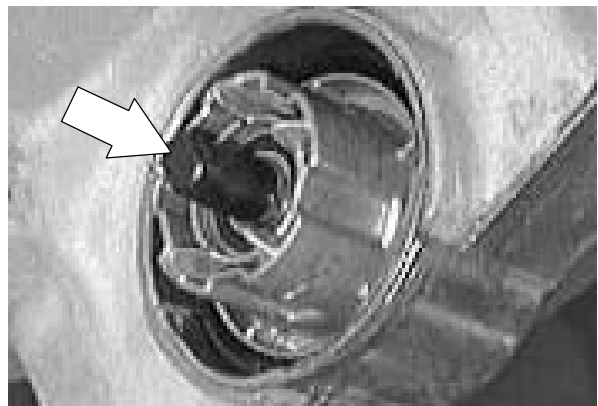

- Use a needle-nose pliers to remove the rubber seal from the scrub head. Remove the drive plug from the scrub head.

*NOTE: RTV sealant is used to seal the drive plug from scrub head water. Use a knife to remove any RTV sealant. DO NOT remove the bottom seal plate.*

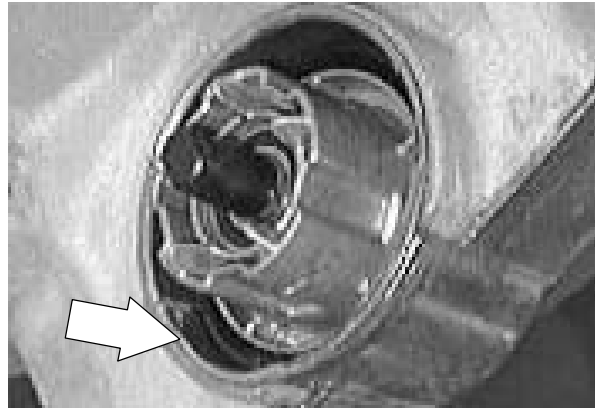

- Remove the brush drive belt from the machine.

*NOTE: It is a tight fit for the belt in the area of the lower belt cover and bottom drive plug. Carefully work the belt past the lower cover--DO NOT remove the lower cover.*

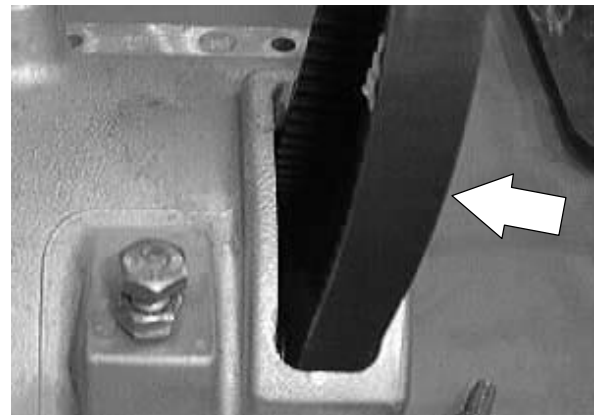

- Slip the new drive belt into position. Push the rest of the drive belt up toward the motor belt pulley. Slip the drive belt over the motor belt pulley.



- Position the brush drive plug and shaft into the belt area. Install the drive belt over the drive plug. Turn the shaft clockwise to tighten. *Use loctite blue 242 on the threads of the shaft before installing.*

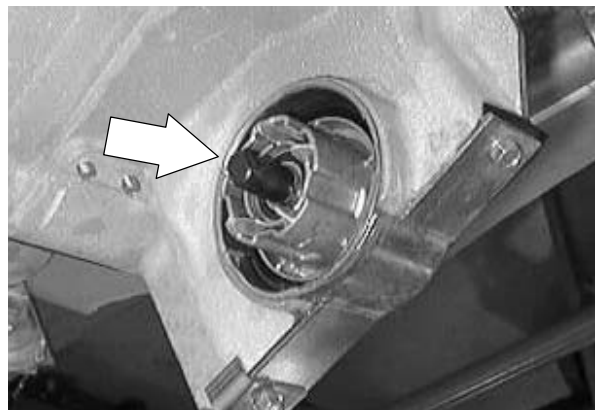

## SCRUBBING

11. Reinstall the rubber seal over the drive plug. Note the orientation of the seal. Use *RTV-Blue sealant* all around the seal when installing.

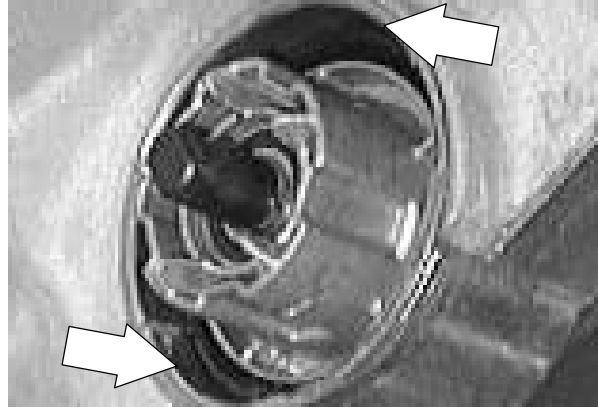

12. Use the tension bolt under the drive motor to tighten the drive belt. Apply 3.0 – 5.0 lbs of force to the drive belt in the middle of the span. The belt should deflect 0.10 inch.

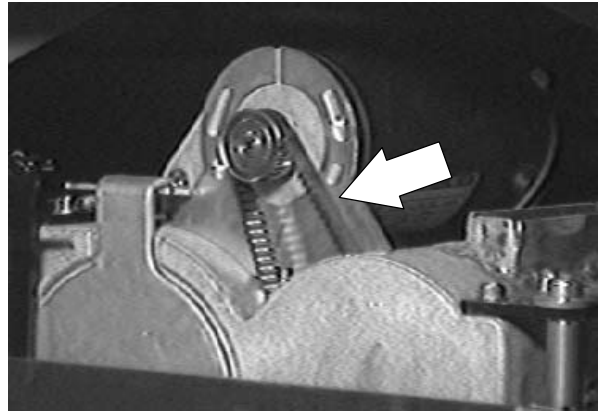

13. Tighten the drive motor pivot bolts to 18 – 24 Nm (15 – 20 ft lb). Re-check the belt tension. Tighten the two motor pivot screws to 18 – 24 Nm (15 – 20 ft lb). Re-check the belt tension.

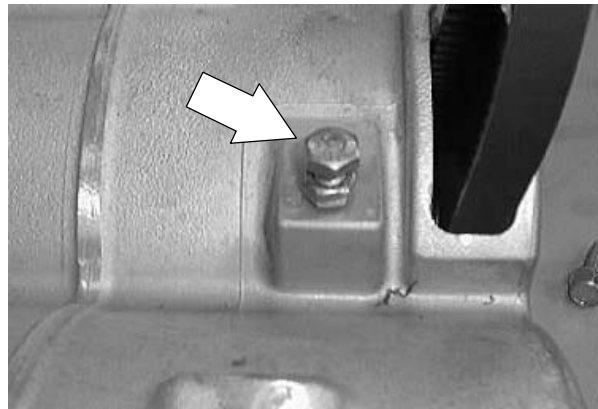

14. Reinstall the belt cover. Tighten the screws to 11 – 14 Nm (7 – 10 ft lb).

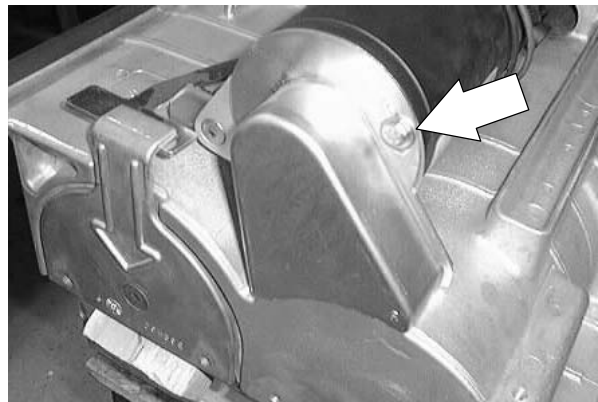

15. Reinstall the scrub brushes. See TO REPLACE CYLINDRICAL SCRUB BRUSHES instructions.

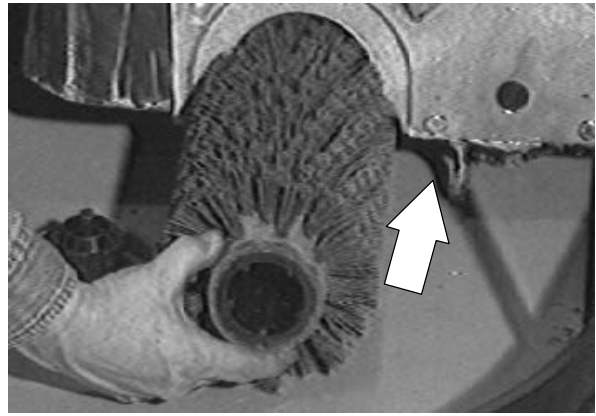

16. Operate the machine and check the scrub brushes for proper operation.



## SCRUBBING

### TO REPLACE BRUSH DRIVE PLUG BEARINGS

**FOR SAFETY: Before Leaving Or Servicing Machine; Stop On Level Surface, Set Parking Brake.**

1. Remove the scrub brush drive plug. See TO REPLACE BRUSH DRIVE BELT instructions in this section.

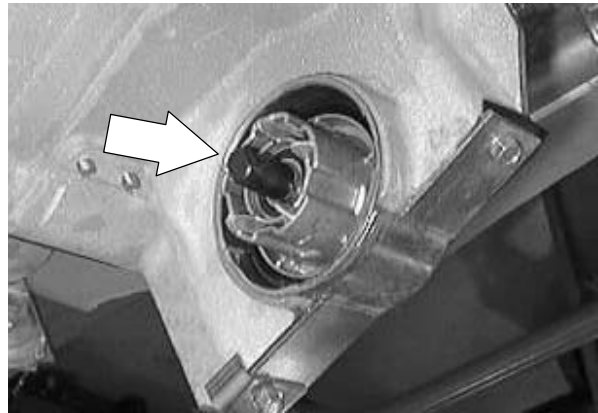

2. Remove the retainer ring from the drive plug shaft.

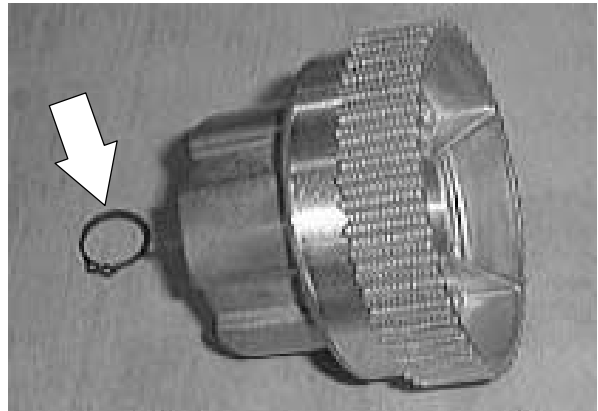

3. Use an arbor press to remove the shaft from the drive plug.

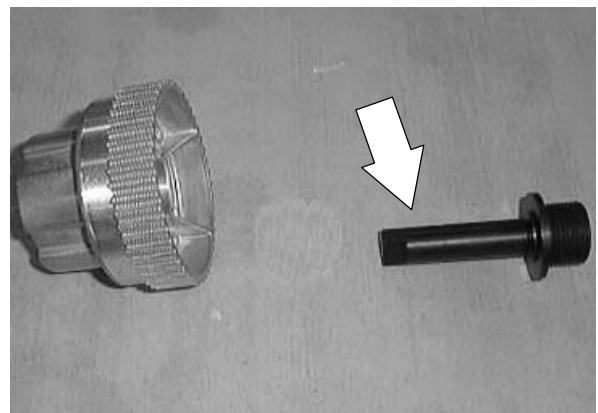

4. Use a punch and hammer to remove both bearings from the drive plug.

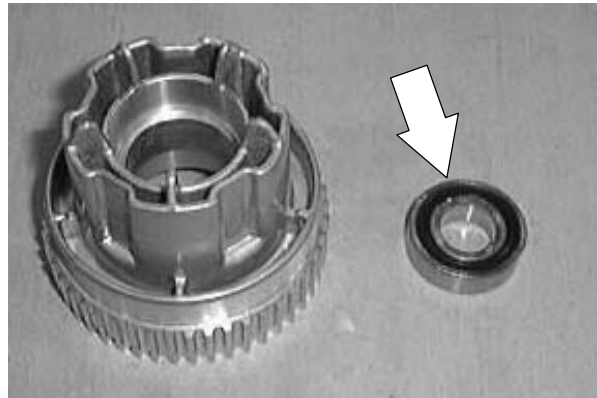

5. Use an arbor press to install new bearings into each end of the drive plug.

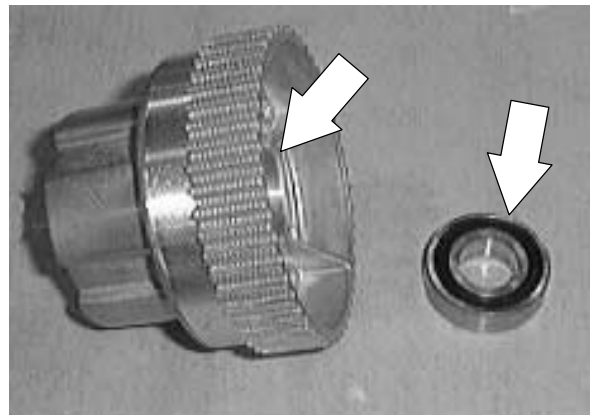

6. Use an arbor press to install the shaft into the new bearings and drive plug.

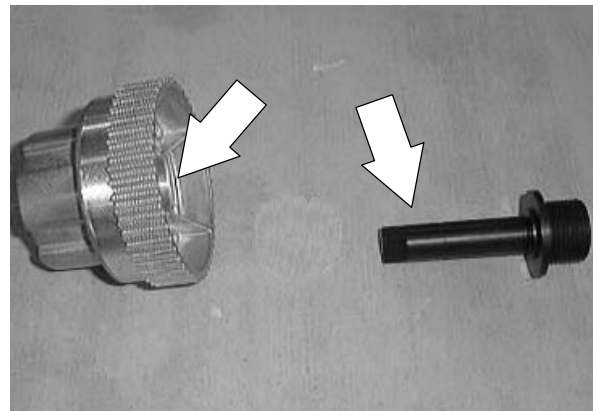

7. Reinstall the retainer ring onto the end of the drive plug shaft.

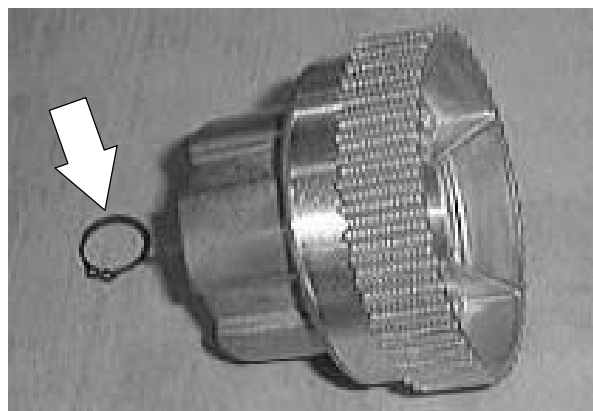

8. Reinstall the scrub brush drive plug. See TO REPLACE BRUSH DRIVE BELT instructions in this section.

## SCRUBBING

### TO REPLACE BRUSH IDLER PLUG

**FOR SAFETY: Before Leaving Or Servicing Machine; Stop On Level Surface, Set Parking Brake.**

1. Remove the scrub brushes. See TO REPLACE CYLINDRICAL SCRUB BRUSHES instructions in this section.

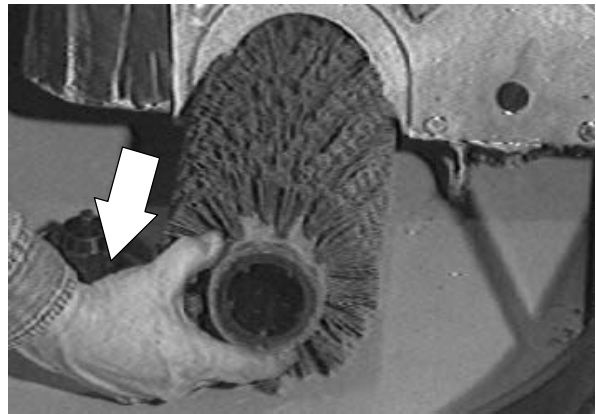

2. Remove the idler plate from the scrub head.

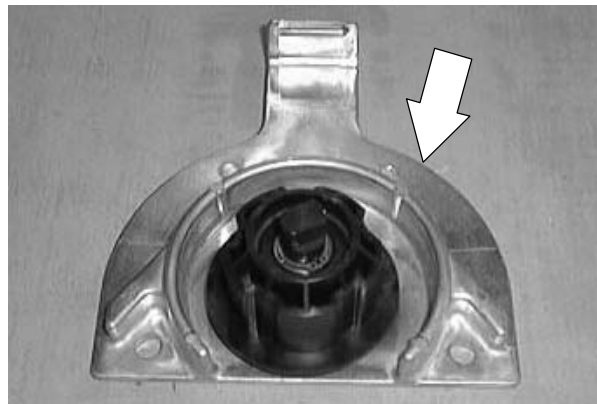

3. Remove the flat screw from the back of the brush idler plate. Remove the idler plug from the plate.





4. Remove the retaining ring from the idler shaft.

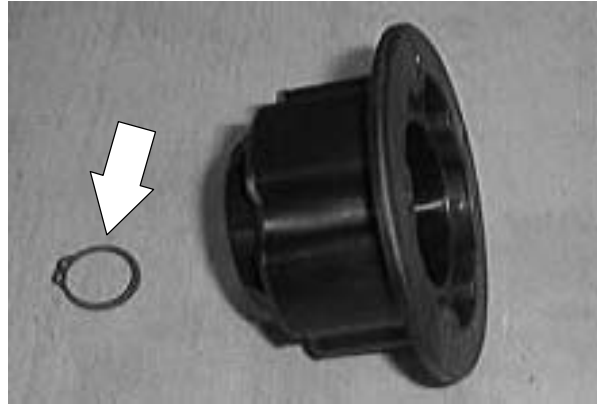

5. Use an arbor press to remove the shaft from the idler plug. Discard the existing idler plug.

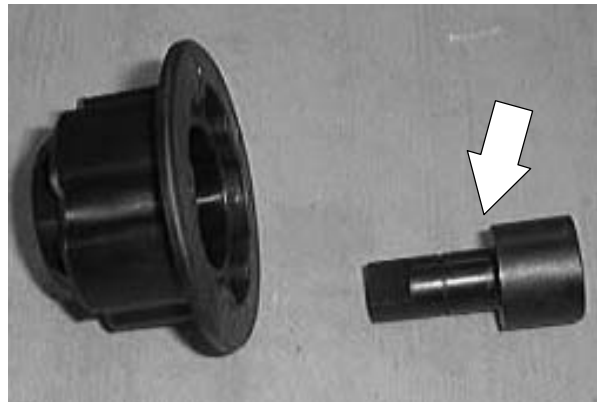

6. Use an arbor press to install the idler shaft into the new idler plug.

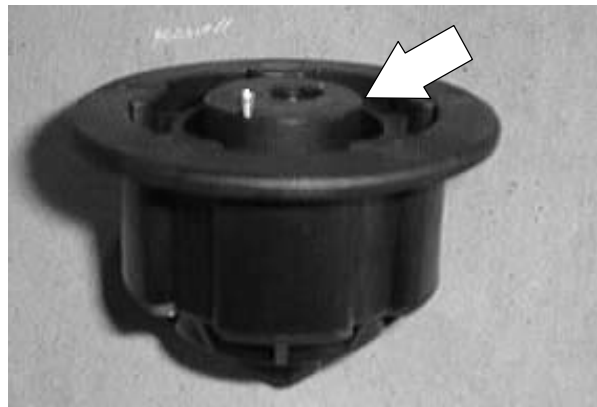

7. Reinstall the retaining ring onto the idler shaft.



## SCRUBBING

8. Reinstall the idler plug onto the brush door plate. Make sure the roll pin in the shaft lines up with the slot in the door plate. Reinstall the flat screw. Position the edge of the idler .06 inch to .09 inch from the bottom edge of the door plate. Tighten the flat screw to 37 – 48 Nm (26 – 34 ft lb).

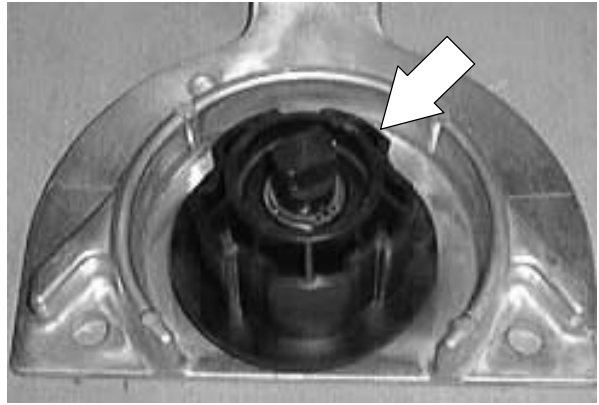

9. Reinstall the scrub brush and idler plate. See TO REPLACE CYLINDRICAL SCRUB BRUSHES instructions in this section.



**TO REPLACE SCRUB HEAD LIFT ARM BEARINGS (ROLL-OUT BATTERY OPTION MACHINES ONLY)**

**FOR SAFETY: Before Leaving Or Servicing Machine; Stop On Level Surface, Set Parking Brake.**

1. Remove the scrub head. See TO REMOVE CYLINDRICAL/DISC SCRUB HEAD instructions in this section.

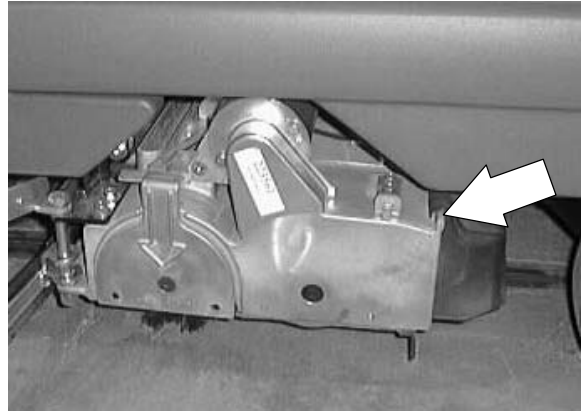

2. Remove the cotter pin and clevis pin from the bottom of the scrub head lift actuator where it attaches to the scrub head lift arm.

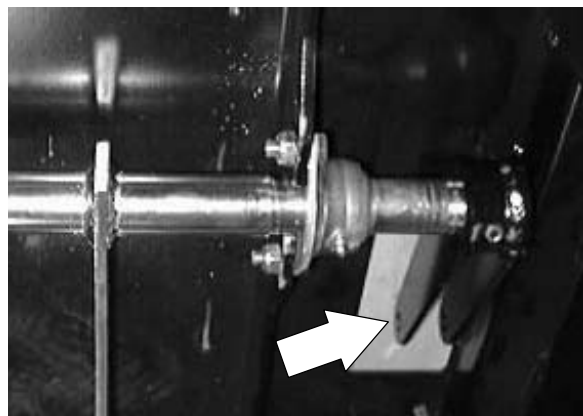

3. Remove the four hex screws holding the two left arm bearings to the machine frame. Remove the scrub head lift arm from the machine.



## SCRUBBING

4. Locate the roll pin holding the actuator lever to the end of the left arm. Remove the actuator lever from the lift arm. *NOTE the orientation of the lever to the arm.*

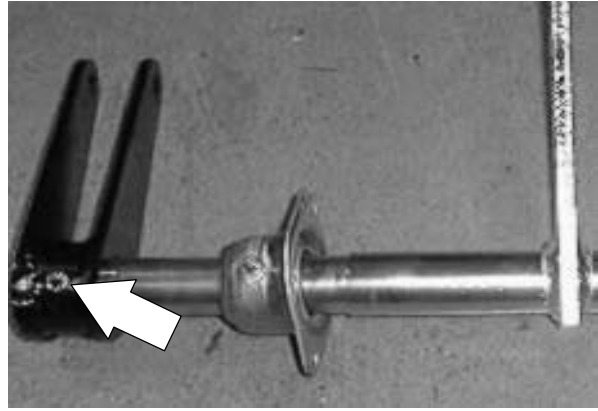

5. Slip the bearing off the end of the lift arm. Discard the existing bearing. Install the new bearing in the same orientation.

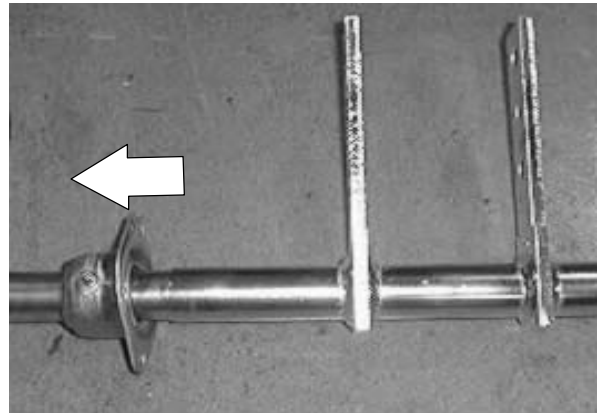

6. Position the actuator lever onto the end of the lift arm in the same orientation it was removed. Use a hammer to reinstall the roll pin.

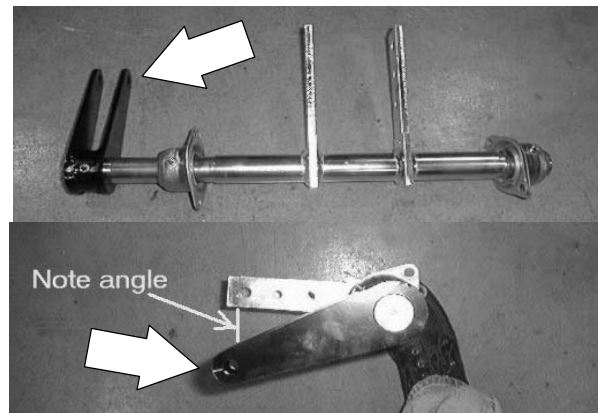

7. Go to the other end of the lift arm. Remove the outside retainer ring from the end of the lift arm.



- Slip the bearing off the end of the lift arm. Discard the existing bearing. Install the new bearing in the same orientation. Reinstall the retainer ring on the end of the lift arm.

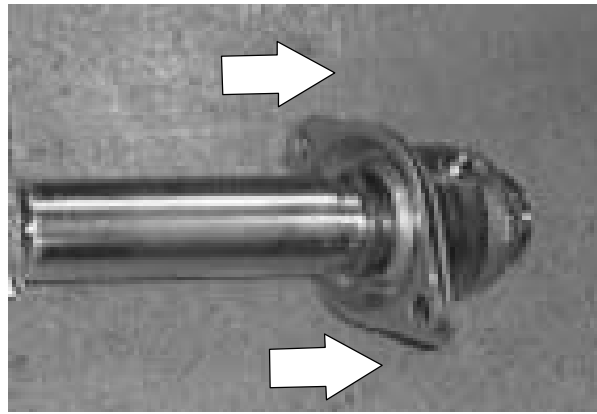

- Reinstall the lift arm assembly back under the machine frame. *NOTE: The bearings are positioned on the outside of the machine frame rails.*

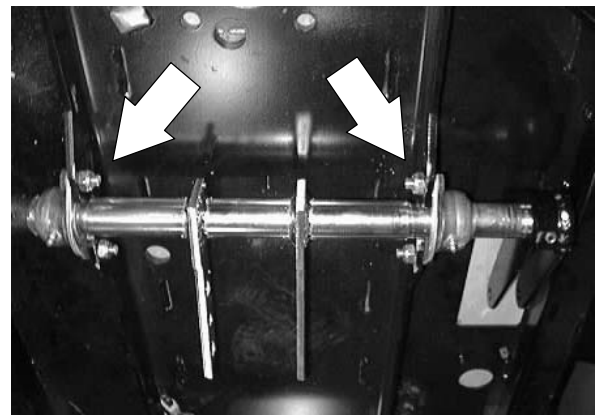

*NOTE: Make sure to position the grease zerk pointing down. Pump 6 pumps of grease into each new bearing.*

- Reinstall the four hex screws and nuts. Tighten to 37 – 48 Nm (26 – 34 ft lb).

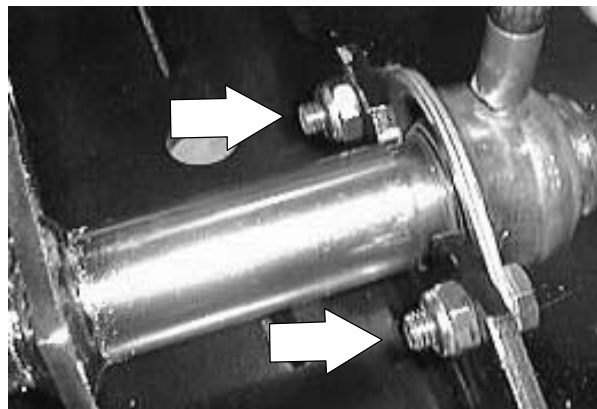

- Reconnect the scrub head lift actuator to the lift arm. Reinstall the clevis pin and cotter pin.

- Reinstall the scrub head. See TO INSTALL CYLINDRICAL/DISC SCRUB HEAD instructions in this section.

- Operate the machine. Check the scrub head lift for proper operation.

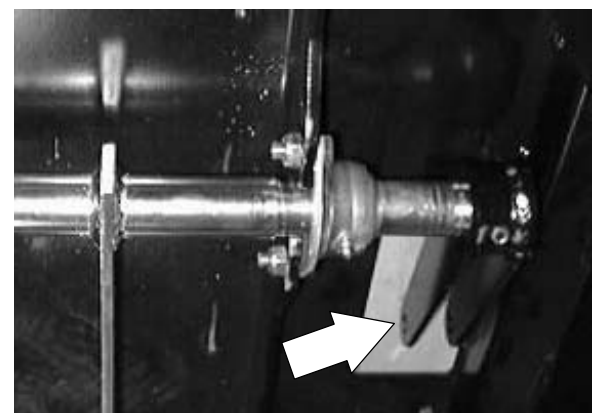

## MANUAL SOLUTION VALVE

The manual solution valve is located under the floor plate on the left side of the machine. This valve controls the amount of water being sent to the scrub brushes. The control lever is located in the operators compartment, next to the operators left leg.

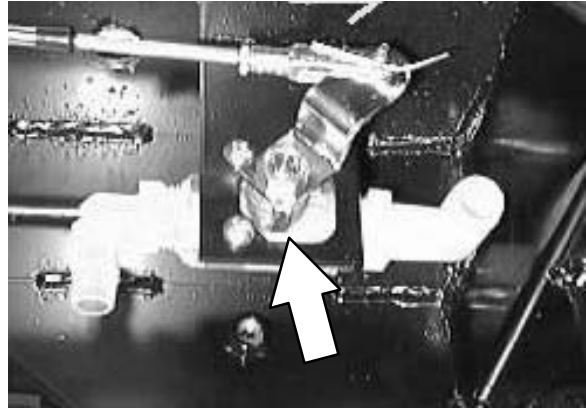

## TO REPLACE SOLUTION VALVE

1. Drain the solution tank.

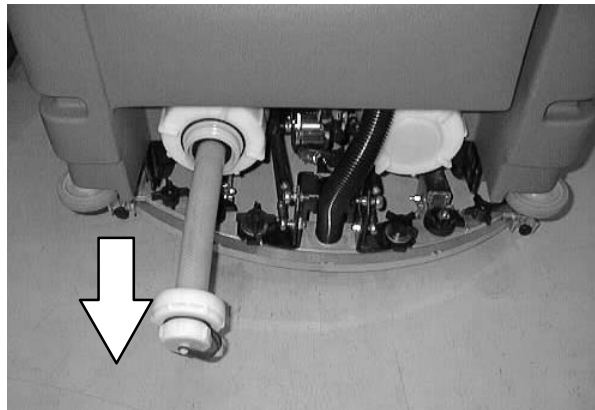

2. Lower the scrub head to the floor.

**FOR SAFETY: Before Leaving Or Servicing Machine; Stop On Level Surface, Set Parking Brake.**

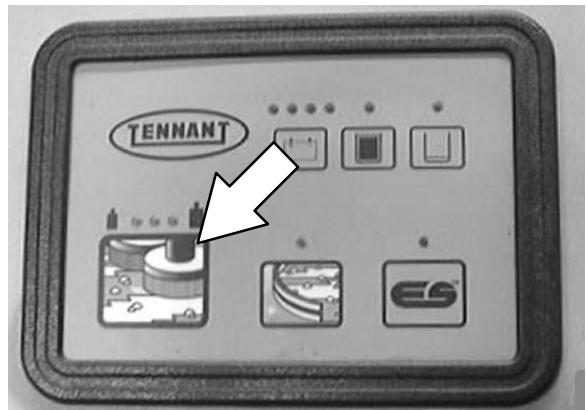

3. Go under the machine on the left side.

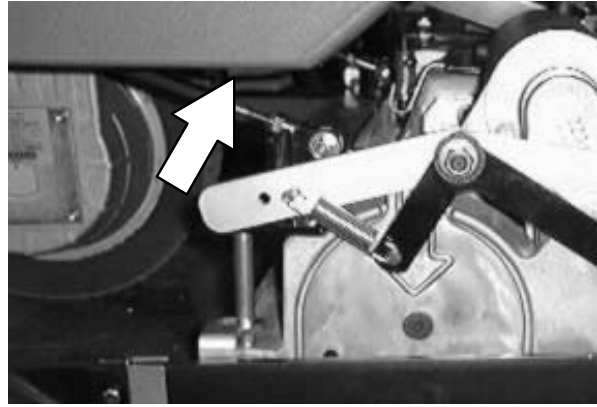

4. Locate the manual solution valve above the scrub head.

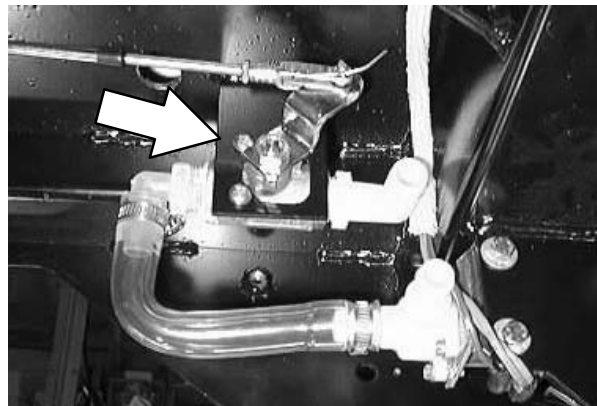

5. Remove the cotter pin from the control lever rod where it attaches to the valve. Pop the rod out of the mount hole.

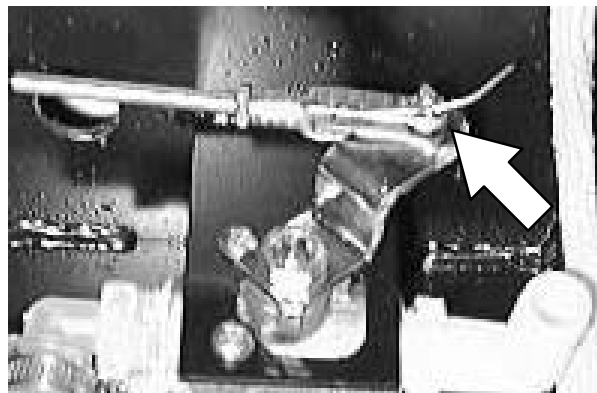

6. Loosen the worm drive clamps holding the two solution hoses to the valve fittings. Pull the hoses off the fittings.

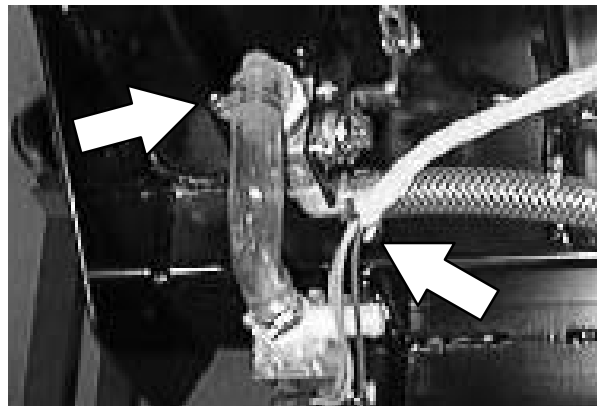

## SCRUBBING

7. Remove the two screws holding the valve to the machine frame. Remove the manual valve from the machine.



8. Remove the fittings from the old valve and install in the new valve in the same orientation.

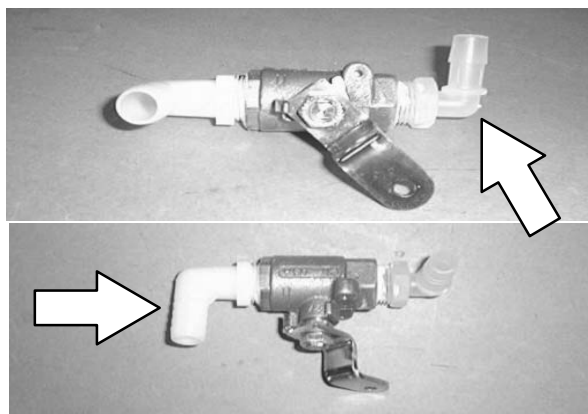

9. Remove the lever from the old valve and install it on the new valve in the same orientation.

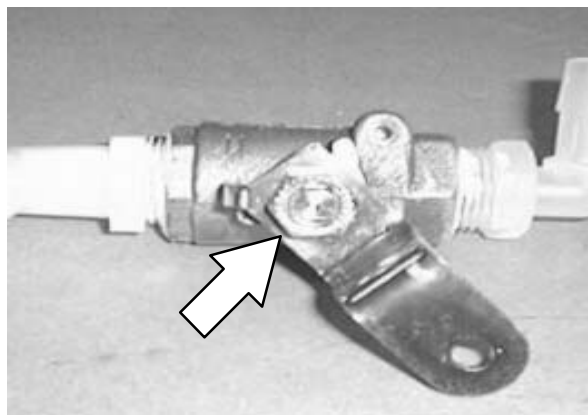

10. Install the new valve on the machine. Hand tighten the screws.

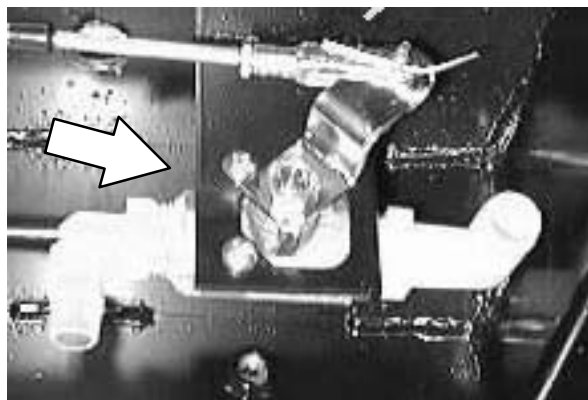



11. Reconnect the two solution hoses. Hand tighten the worm drive clamps.

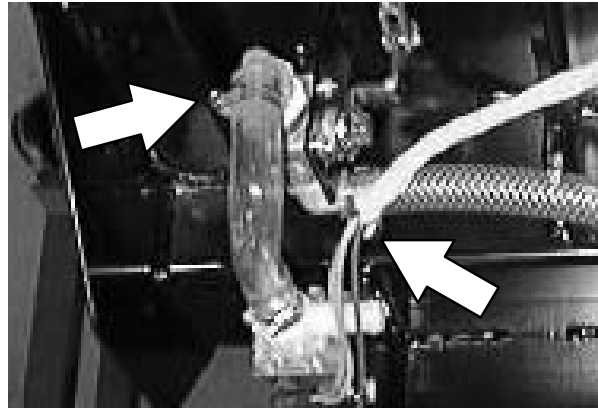

12. Place the control lever rod in the mount hole and install the cotter pin.

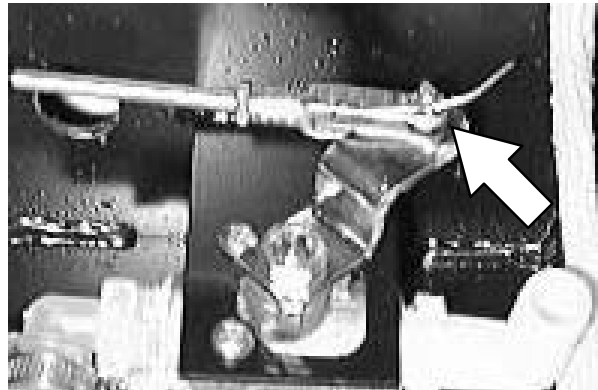

13. Operate the machine and check the water valve for proper operation.

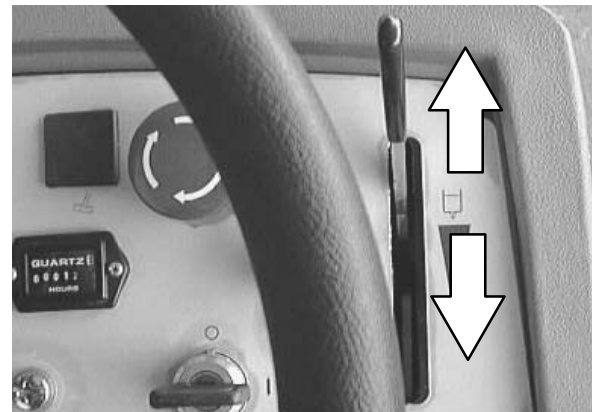

# SCRUBBING

## SQUEEGEES

The rear squeegee assembly channels water into the vacuum fan suction. The front blade channels the water, and the rear blade wipes the floor.

Check the squeegee blades for damage and wear daily. Rotate or replace either of the squeegee blades if the leading edge is torn or worn half-way through the thickness of the blade.

The squeegee can be adjusted for leveling and deflection. The deflection and leveling of the squeegee blades should be checked daily, or when scrubbing a different type of floor.

The squeegee assembly can be removed from the squeegee pivot to prevent damage during transport of the machine.

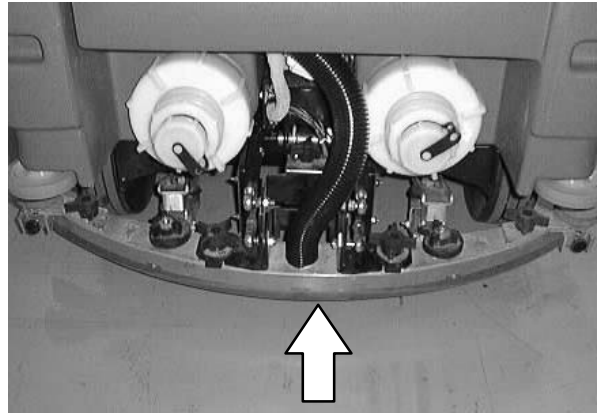

## SQUEEGEE WHEEL CAMS

The *squeegee wheel cams* adjust the rear squeegee deflection along the entire length of the rear squeegee. There are wheel cams at either end of the squeegee.

*Increase deflection:* Turn the cams counterclockwise.

*Decrease deflection:* Turn the cams clockwise.

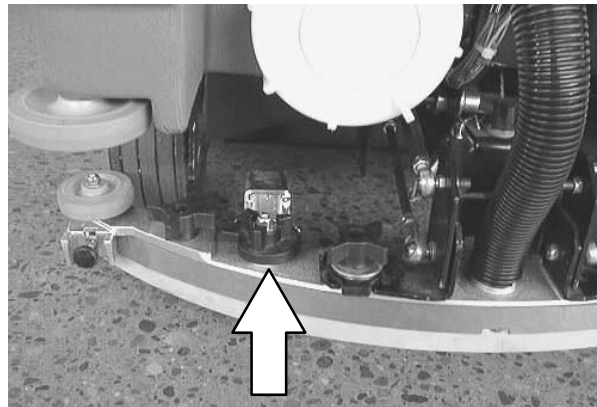

## SQUEEGEE LEVELING KNOB

The *squeegee leveling knob* adjusts the deflection at the ends of the rear squeegee.

The *squeegee leveling knob* is located directly behind the squeegee suction hose. **DO NOT** disconnect the suction hose from the squeegee frame when leveling the squeegee.

*Increase end deflection:* Turn the *squeegee leveling knob* counterclockwise to increase the deflection at the end of the squeegees.

*Decrease end deflection:* Turn the *squeegee leveling knob* clockwise to decrease the deflection at the end of the squeegees.

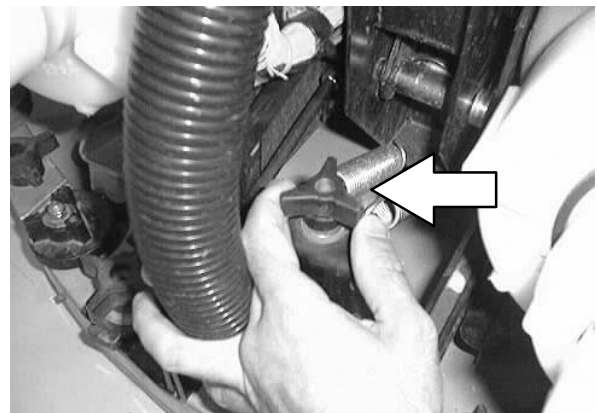

**TO REMOVE REAR SQUEEGEE ASSEMBLY**

1. Lower the squeegee to approximately 25 mm (1 in.) from the floor.

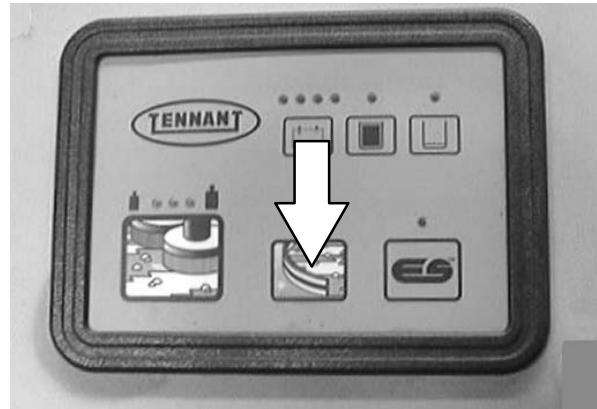

2. Turn the machine power off and set the parking brake.

**FOR SAFETY: Before Leaving Or Servicing Machine; Stop On Level Surface, Set Parking Brake.**



3. Remove the squeegee suction hose from the squeegee.

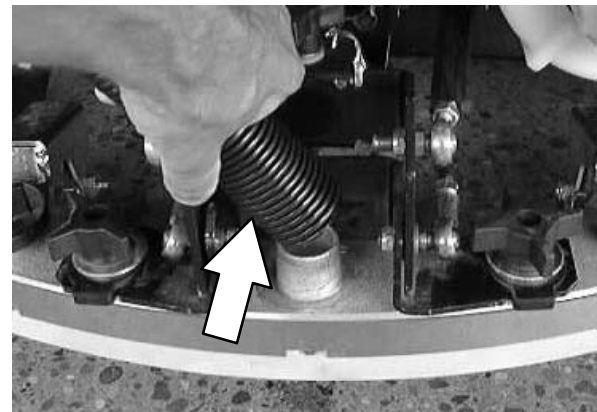

## SCRUBBING

4. Remove both squeegee mounting knobs.

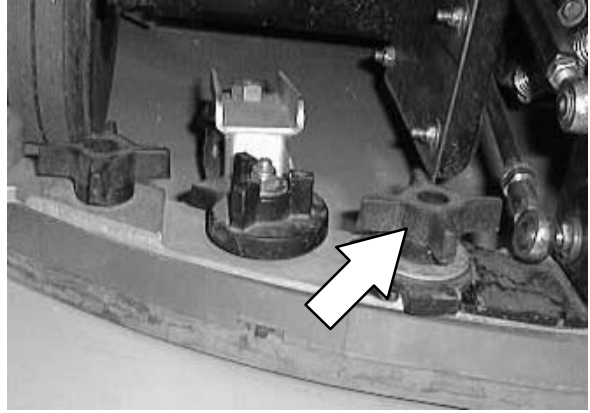

5. Pull the squeegee assembly off the machine.

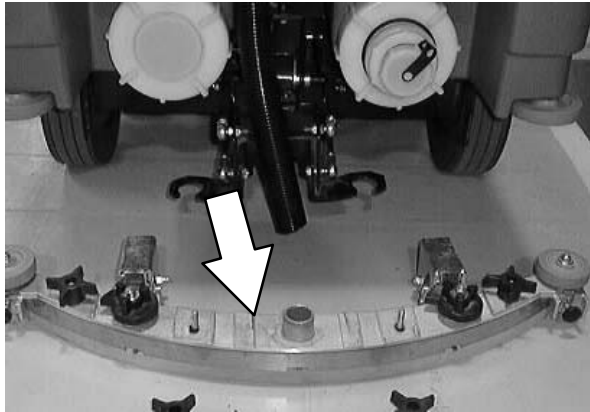

**TO INSTALL REAR SQUEEGEE ASSEMBLY**

1. Make sure the squeegee pivot is lowered.

**FOR SAFETY: Before Leaving Or Servicing Machine; Stop On Level Surface, Set Parking Brake.**

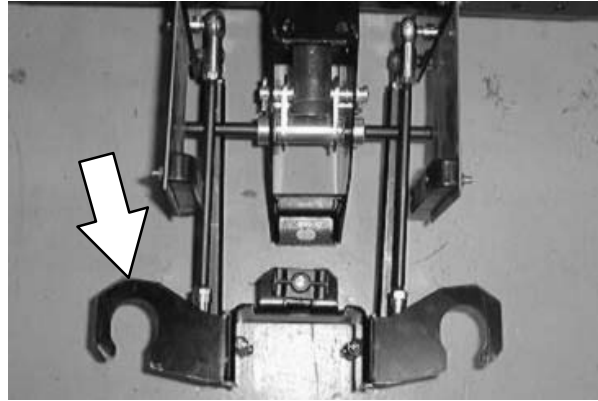

2. Place the squeegee under the squeegee pivot.

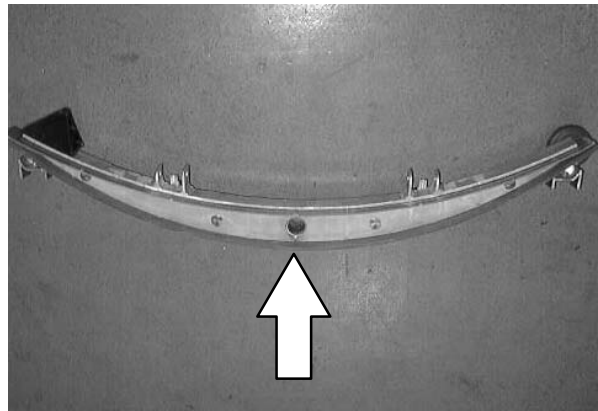

3. Push the squeegee frame onto the squeegee pivot.

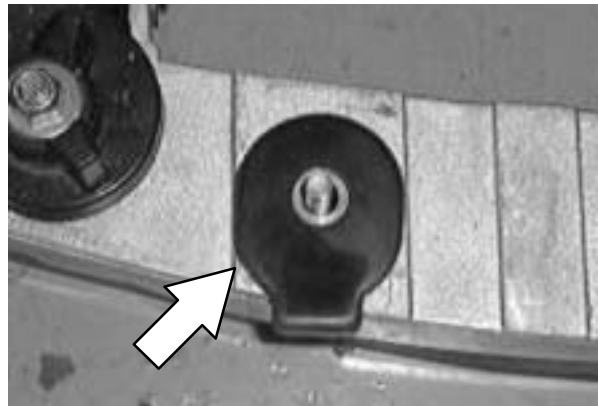

## SCRUBBING

4. Tighten the mounting knobs.

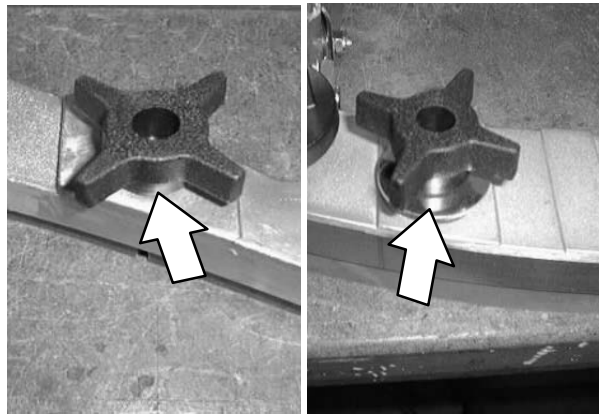

5. Push the squeegee suction hose onto the squeegee fitting.

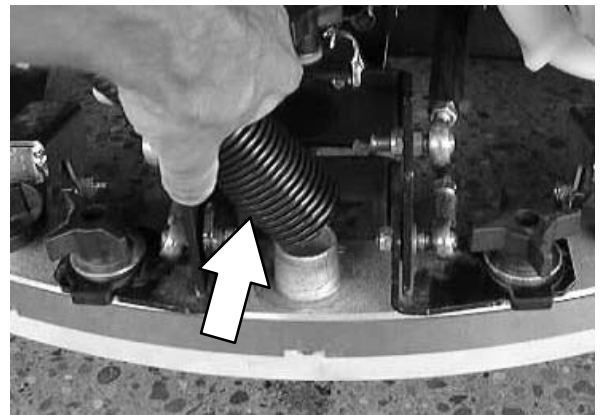

6. Operate the machine. Check the rear squeegee for proper roll-out and levelness.

*NOTE: Make sure the rear squeegee upper and lower links are adjusted to the proper length. **(10.5 inches)** from the center lines of the rod ends.*

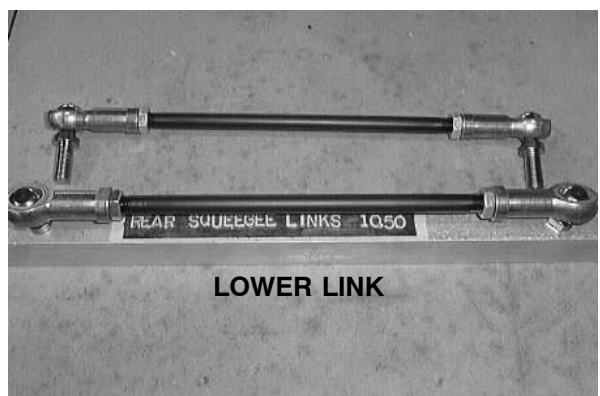

## TO LEVEL REAR SQUEEGEE

Leveling of the squeegee assures even contact for the length of the squeegee blade with the surface being scrubbed. Make sure this adjustment is done on an even, level floor.

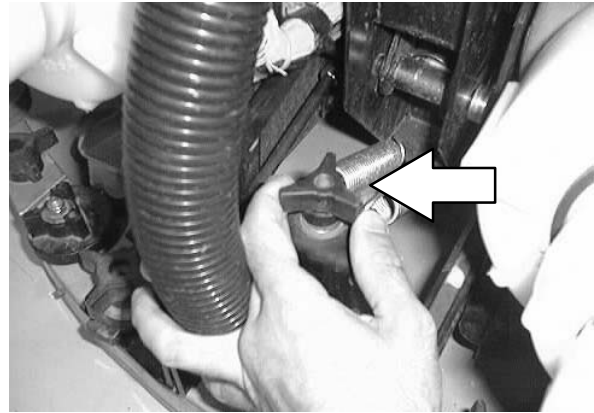

1. Turn the machine power on.



2. Lower the squeegee.

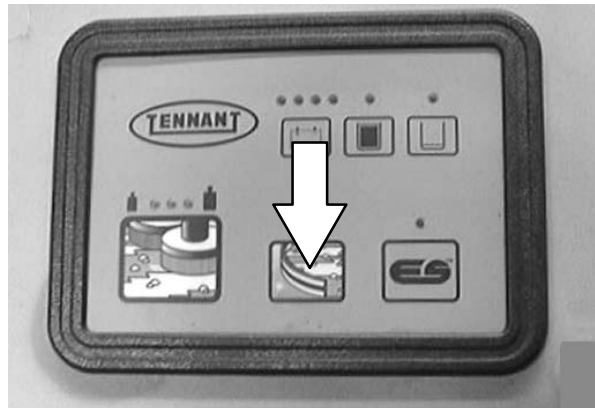

3. Drive the machine forward a few feet, then set the parking brake. Shut off the machine.

**FOR SAFETY: Before Leaving Or Servicing Machine; Stop On Level Surface, Set Parking Brake.**

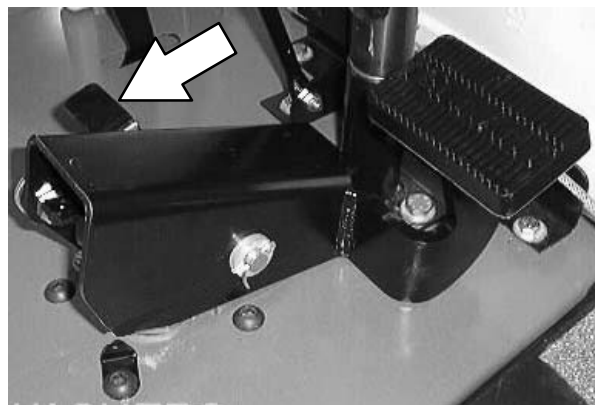

## SCRUBBING

4. Check the deflection of the squeegee over the full length of the squeegee blade.

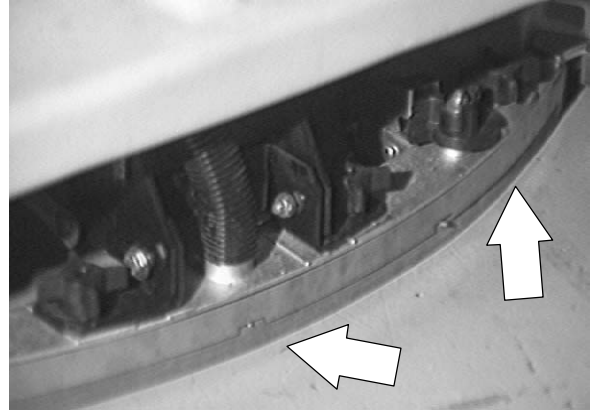

5. If the deflection is NOT the same over the full length of the blade-- turn the squeegee leveling knob to make adjustments.

The squeegee leveling knob is located directly behind the squeegee suction hose. **DO NOT** disconnect the suction hose from the squeegee frame when leveling squeegee.

-Turn the squeegee leveling knob **counter-clockwise to increase** the deflection at the ends of the squeegee.

-Turn the squeegee leveling knob **clockwise to decrease the deflection** at the ends of the squeegee blade.

6. Drive the machine forward with the squeegee down to check the squeegee blade deflection.

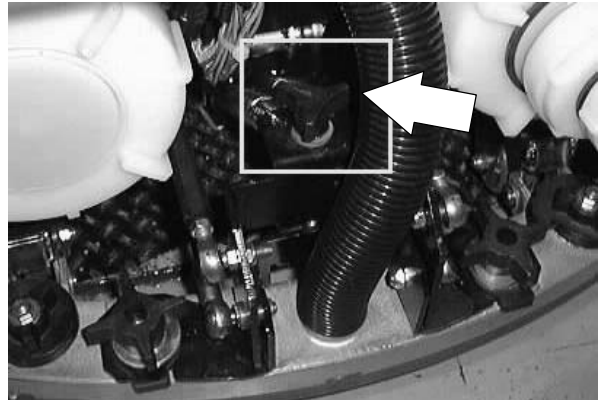

7. Readjust the squeegee blade deflection if necessary.

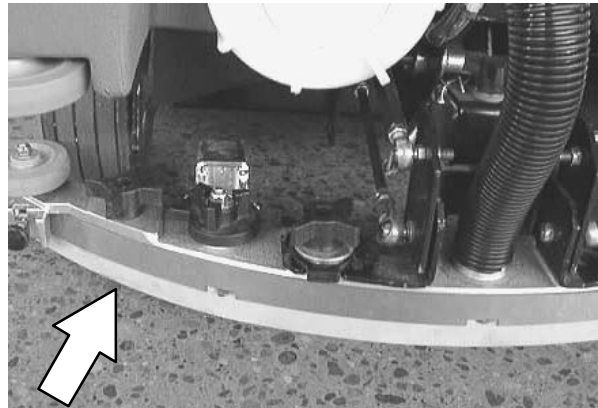



**TO ADJUST REAR SQUEEGEE BLADE DEFLECTION**

Deflection is the amount of curl the squeegee blade has when the machine moves forward while the squeegee lowered to the floor. The best deflection is when the squeegee wipes the floor just dry with a minimum amount of deflection.

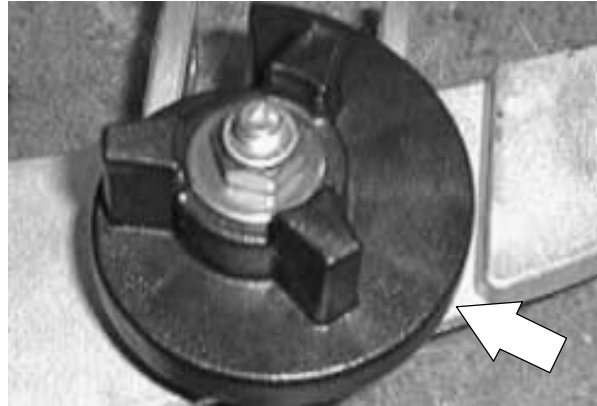

1. Turn the machine power on.



2. Lower the squeegee.

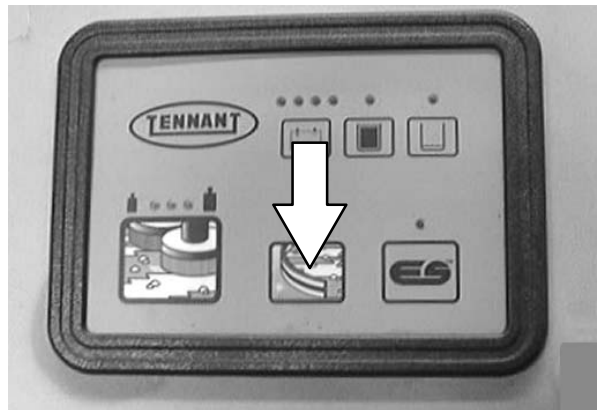

## SCRUBBING

3. Drive the machine forward, and look at the deflection of the squeegee blade. The correct amount of deflection is 12 mm (0.50 in) for scrubbing smooth floors and 15 mm (0.62 in) for rough floors.

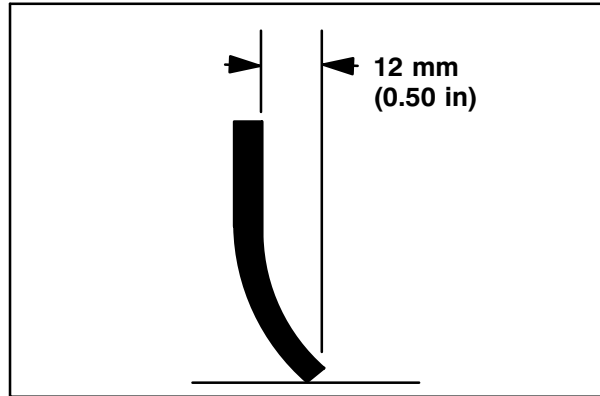

03719

4. To adjust the amount of deflection, turn the squeegee deflection cams clockwise to decrease the blade deflection.

*Turn the squeegee deflection cams counter-clockwise to increase blade deflection.*

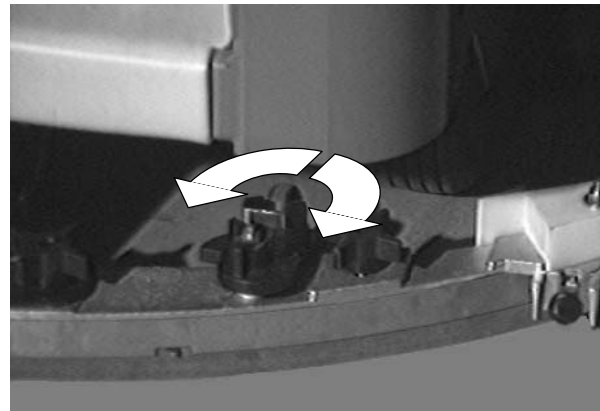

5. Drive the machine forward again to check the squeegee blade deflection.

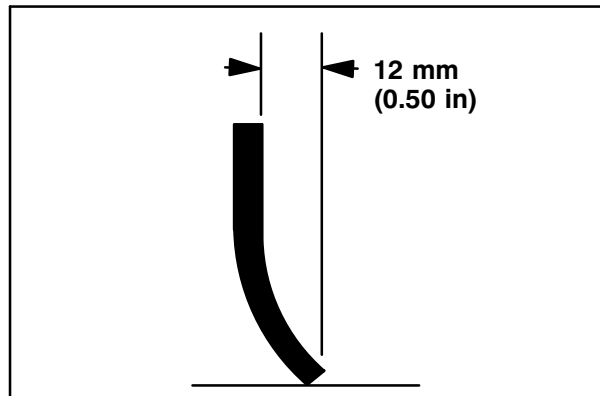

03719

6. Readjust the squeegee blade deflection if necessary.

**REAR SQUEEGEE CASTERS**

The rear squeegee casters each have two grease fittings. Lubricate the pivot point and caster bearing on each squeegee caster with Lubriplate EMB grease (TENNANT part no. 01433-1) every 50 hours

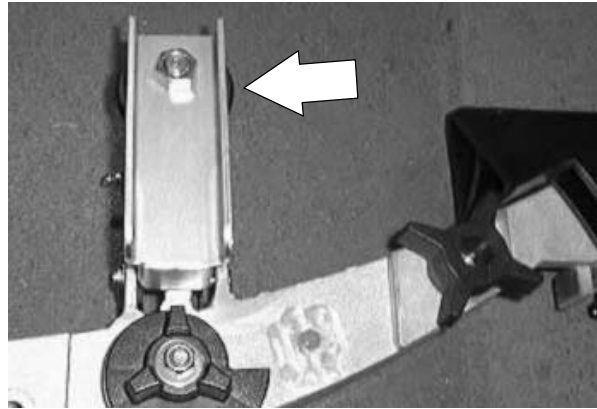

**TO ADJUST REAR SQUEEGEE GUIDE ROLLER**

On the left end of the squeegee is a guide roller that guides the squeegee blade end along a wall. Loosen the nut at the top of the guide roller and move the roller in or out to adjust how close the end of the squeegee blade is to the wall. The squeegee blade end should be further away from the wall when the floor curves up into the wall.

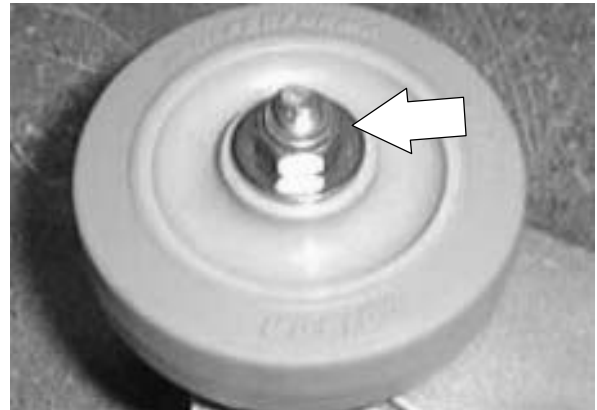

**REAR SQUEEGEE SPRINGS**

The rear squeegee springs are used to bring the squeegee assembly back to center after it comes in contact with an object.

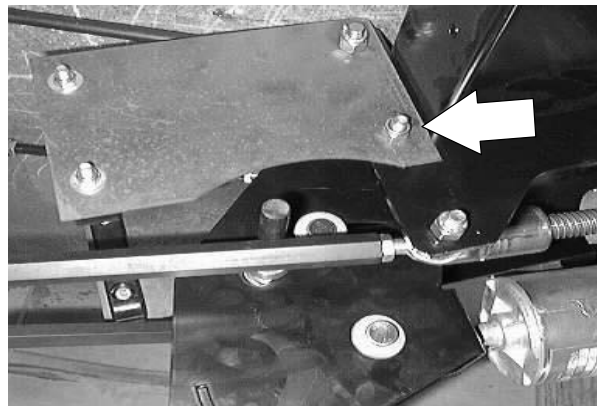

## REAR SQUEEGEE BLADES

The rear squeegee has two squeegee blades, the front and rear. Each blade has four wiping edges. To use them all, start with one wiping edge. To use the next wiping edge, rotate the blade end-for-end. To use the next wiping edge, rotate the top edges down, bottom edges up. To use the last edge, rotate the blade end-for-end. Rotate squeegee blades when they become worn half-way through the thickness of the blade.

Replace damaged squeegee blades.

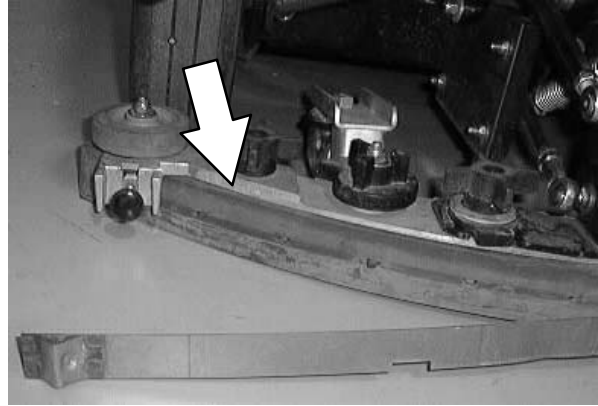

## TO REPLACE OR ROTATE REAR SQUEEGEE (REAR) BLADE

1. Make sure the squeegee is in the raised position.

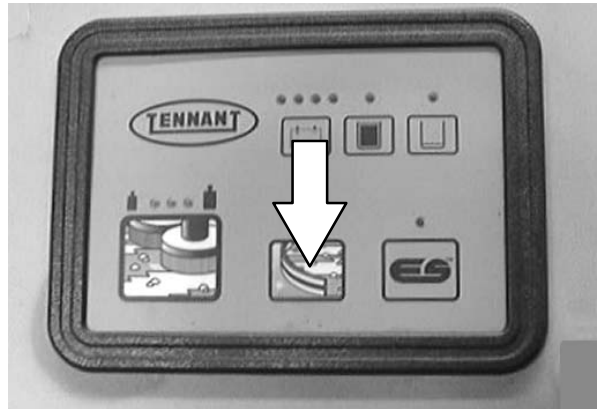

2. Turn the machine power off and set the parking brake.

**FOR SAFETY: Before Leaving Or Servicing Machine; Stop On Level Surface, Set Parking Brake.**

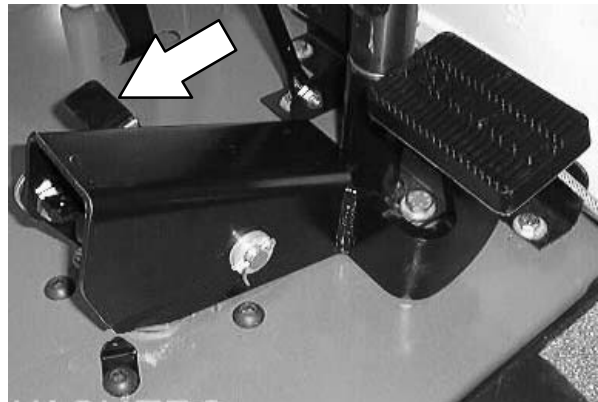

- Loosen the two retainer knobs, one at each end of the squeegee.

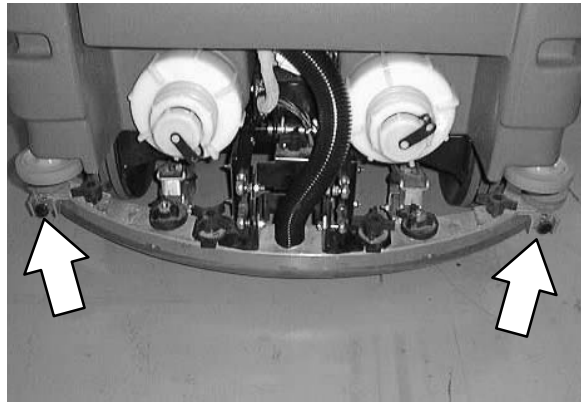

- Pull off the rear retaining band.

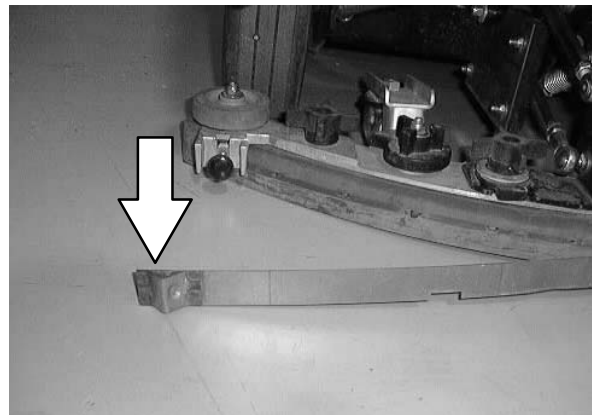

- Pull off the rear squeegee blade.

- Insert the rotated or new squeegee blade and then insert the retainer band.

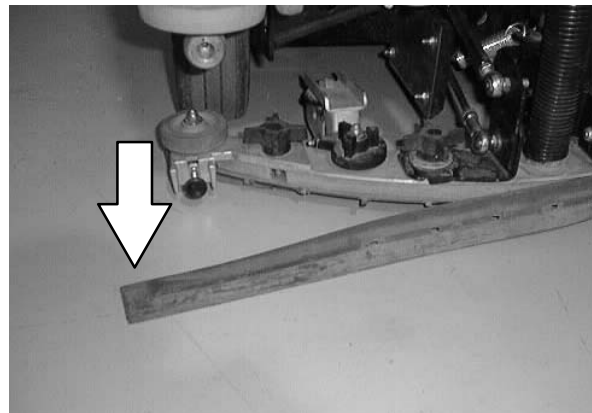

- Tighten the two retainer knobs until the ends of the front and rear squeegee blades touch. Do not over-tighten.

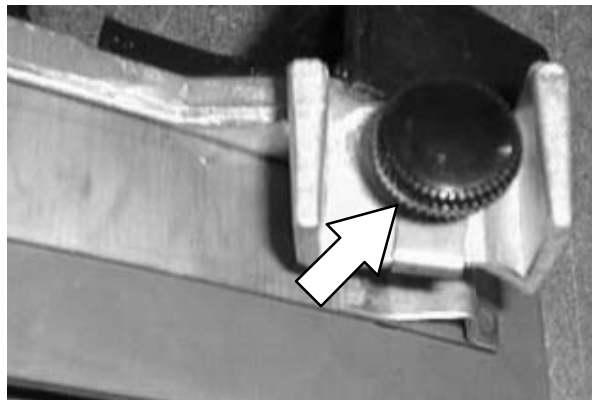

## SCRUBBING

### TO REPLACE OR ROTATE REAR SQUEEGEE (FRONT) BLADE

1. Make sure the squeegee is in the raised position.

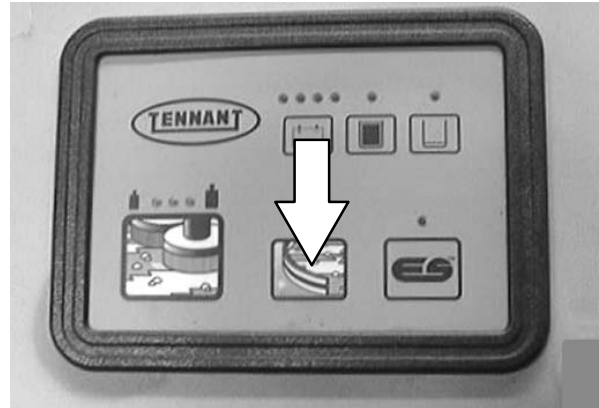

2. Turn the machine power off and set the parking brake.

**FOR SAFETY: Before Leaving Or Servicing Machine; Stop On Level Surface, Set Parking Brake.**

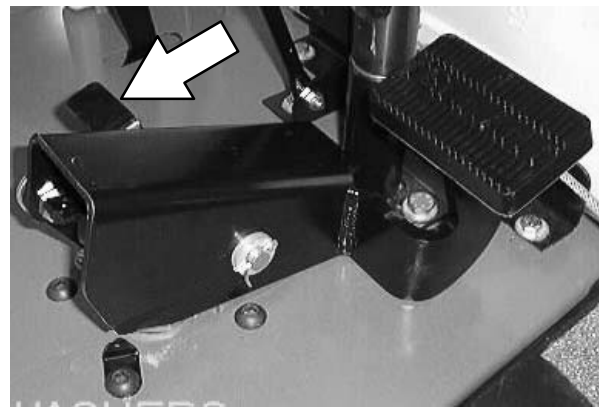

3. Remove the squeegee from the machine. See TO REMOVE SQUEEGEE ASSEMBLY instructions.

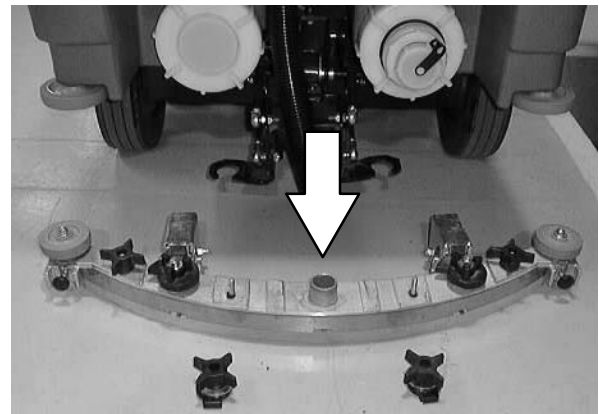

4. Remove the rear squeegee blade and retainer. See TO REPLACE OR ROTATE REAR SQUEEGEE (REAR) BLADE.

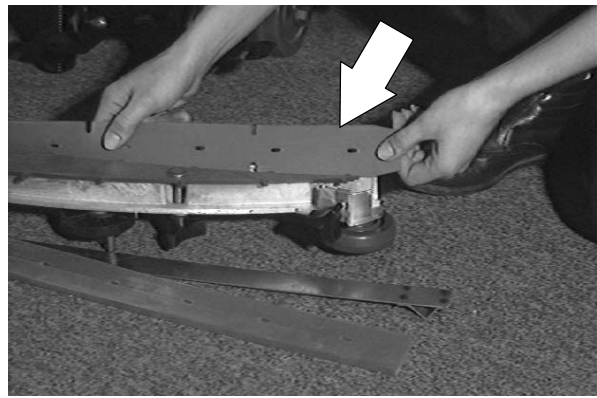

5. Loosen the two remaining knobs on top of the squeegee assembly.

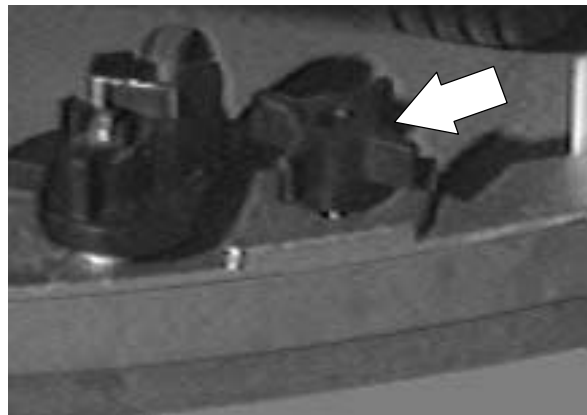

6. Pull the retainer plate back and pull the front squeegee blade out of the squeegee frame.

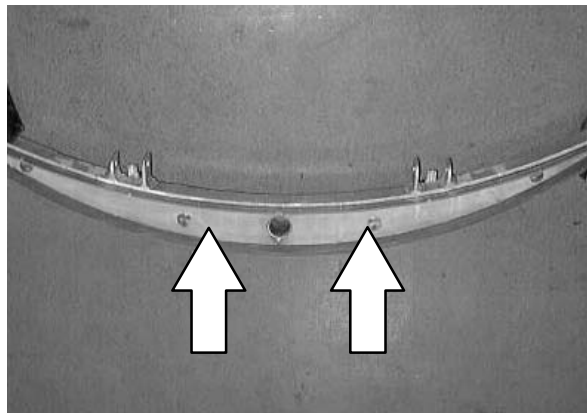

7. Insert the rotated or new squeegee blade in the squeegee frame, lining up the slots in the blade with the tabs on the retainer plate.

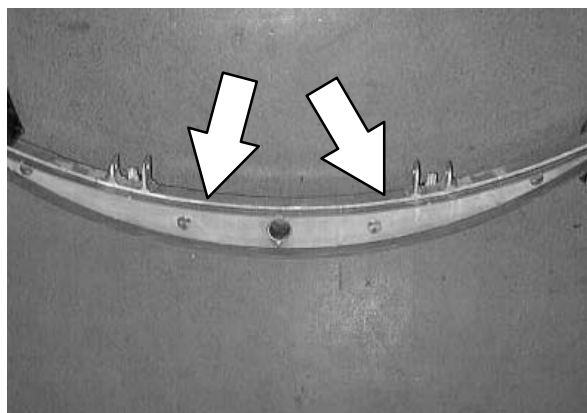

## SCRUBBING

8. Push the retainer plate forward. Tighten the two outside knobs on top of the squeegee assembly.

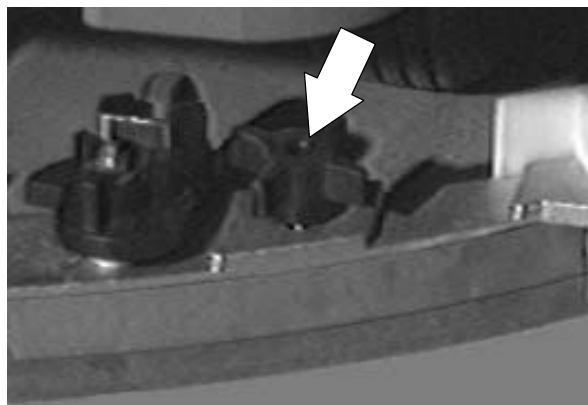

9. Insert the rear squeegee blade and retainer. Tighten the two rear blade retainer knobs until the ends of the front and rear squeegee blades touch. Do not over-tighten.



10. Install the squeegee assembly on the squeegee pivot. See TO INSTALL SQUEEGEE ASSEMBLY instructions.

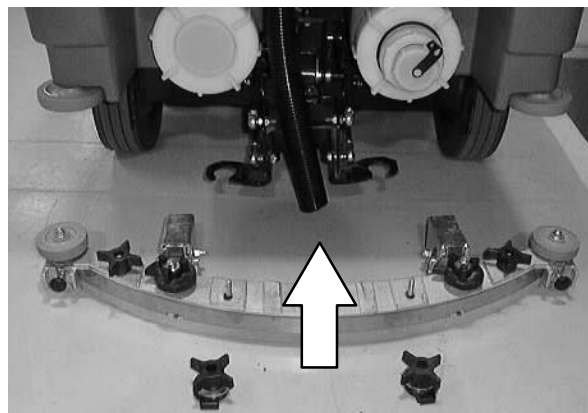

11. Adjust the squeegee blade leveling and deflection as stated in TO LEVEL SQUEEGEE and ADJUST SQUEEGEE BLADE DEFLECTION instructions.

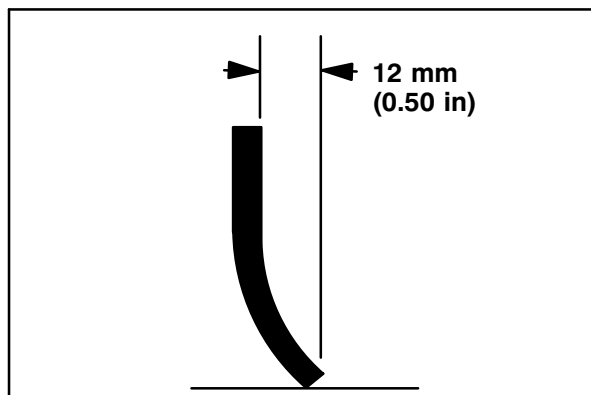

03719



**SIDE SQUEEGEE BLADES**

The side squeegees control water spray and channel water into the path of the rear squeegee. Check the side squeegees for damage and wear daily.

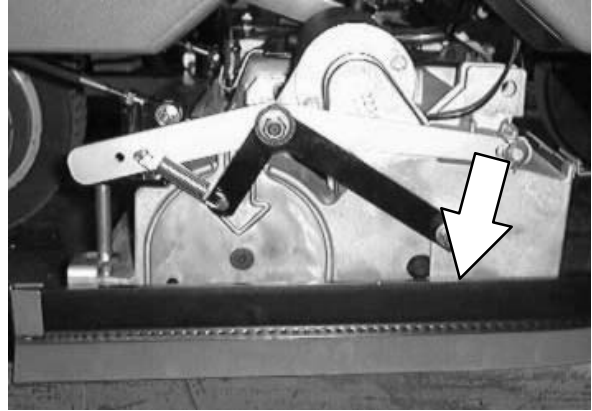

Replace the side squeegee blades if they become damaged or lose their shape. Replace the squeegee deflectors if they become worn.

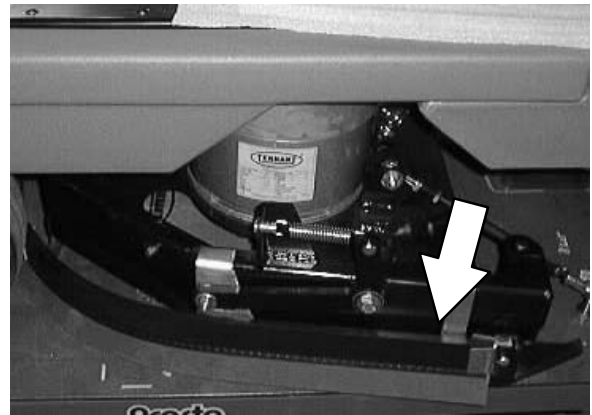

## SCRUBBING

### TO REPLACE SIDE SQUEEGEE BLADES

1. Raise the scrub head.

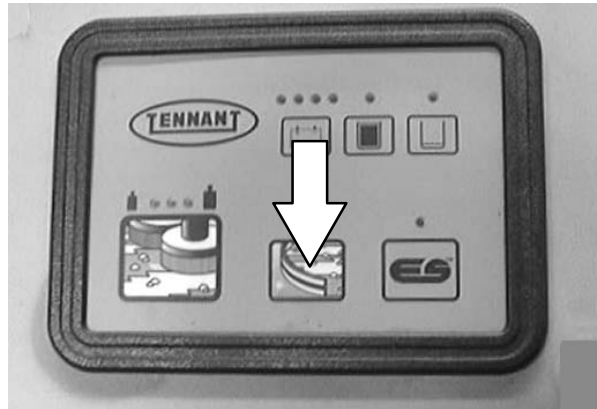

2. Turn the machine power off and set the parking brake.

**FOR SAFETY: Before Leaving Or Servicing Machine; Stop On Level Surface, Set Parking Brake.**

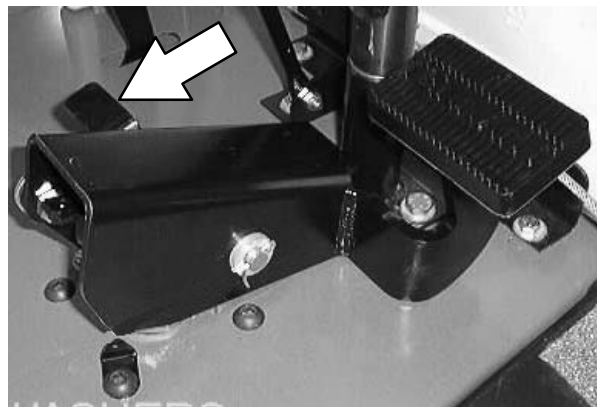

3. Remove the cotter pin, clevis pin, deflector and the retainer bracket from the side squeegee.

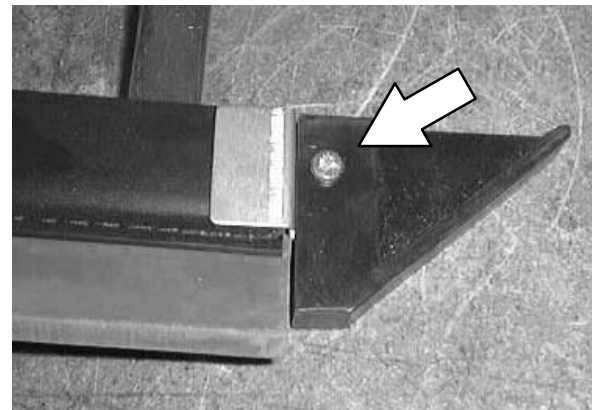

4. Pull the squeegee out of the squeegee frame.

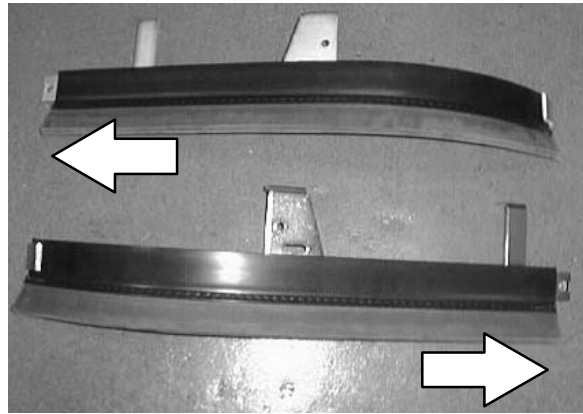

5. Slide a new squeegee blade into the frame.

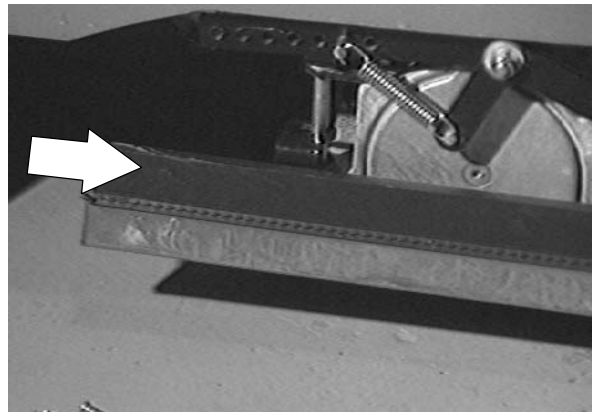

6. Replace the retainer bracket, deflector, clevis pin, and cotter pin.

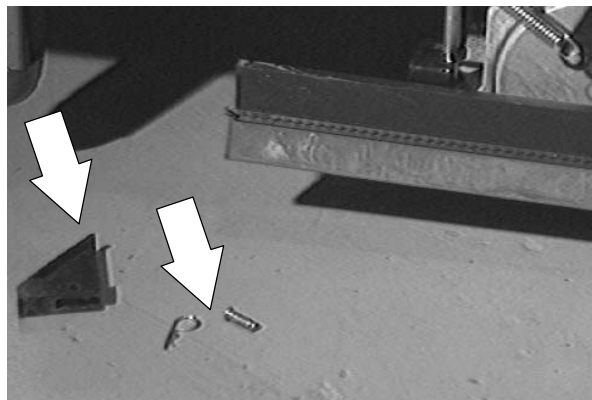

7. Repeat for the side squeegee on the other side of the scrub head.

## VACUUM FAN

The vacuum fan, when activated, creates air flow in the recovery tank. With the recovery tank cover closed, the air flow from the vacuum fan creates vacuum at the squeegee vacuum hose. This vacuum pulls water from the lowered squeegee into the recovery tank. The vacuum fan is equipped with a easily serviceable air filter.

### TO REMOVE VACUUM FAN ASSEMBLY

**FOR SAFETY: Before Leaving Or Servicing Machine; Stop On Level Surface, Set Parking Brake.**

1. Open the recovery/solution tank cover.

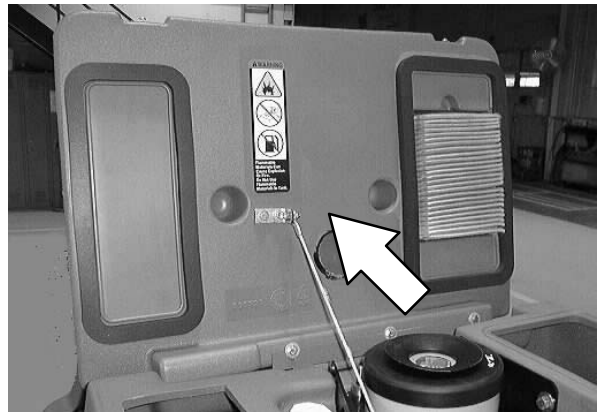

2. Locate the vacuum fan between the solution and recovery tanks.



3. Remove the three screws holding the vacuum fan to the top of the tanks. Pull the vacuum fan assembly out of the top of the tank. Let it rest on the edge of the tank.

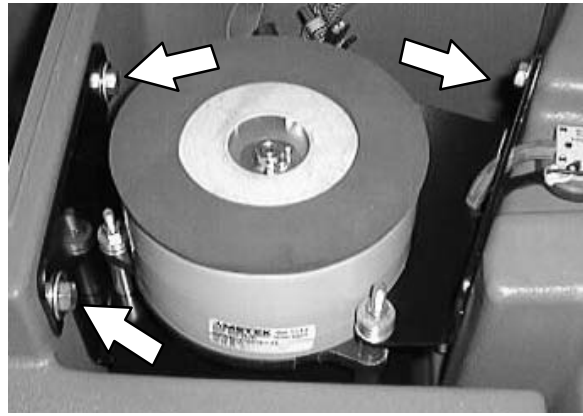

4. Disconnect the vacuum fan exhaust hose from the bottom of the fan outlet port.

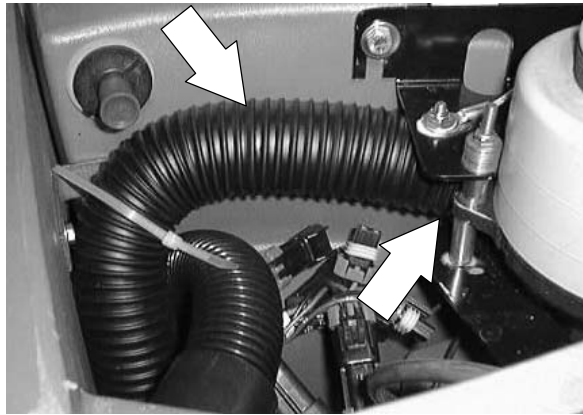

5. Disconnect the vacuum fan motor from the main electrical harness.

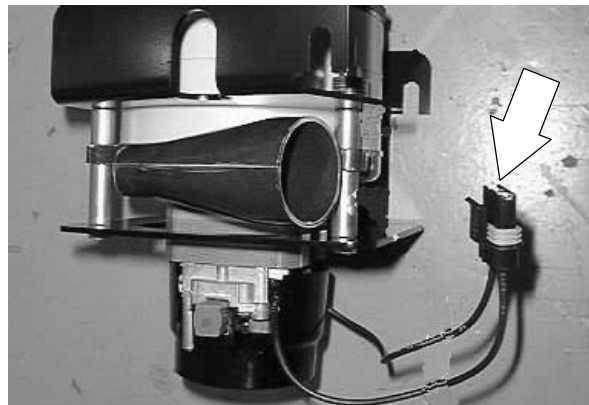

6. Remove the vacuum fan assembly from the machine. Be careful not to lose the rubber seal on the outlet of the vacuum housing.

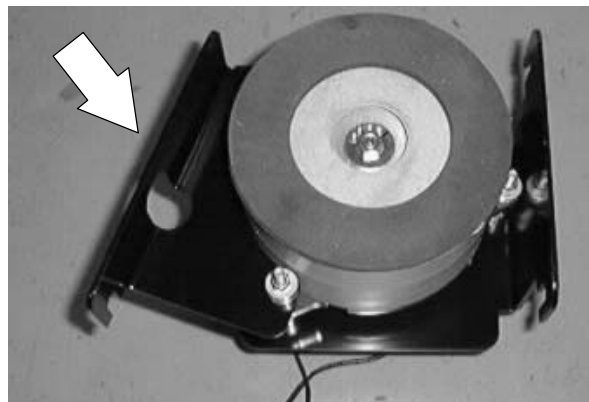

## SCRUBBING

### TO INSTALL VACUUM FAN ASSEMBLY

**FOR SAFETY: Before Leaving Or Servicing Machine; Stop On Level Surface, Set Parking Brake.**

1. Open the recovery/solution tank cover. Position the vacuum fan to the edge of the tanks.

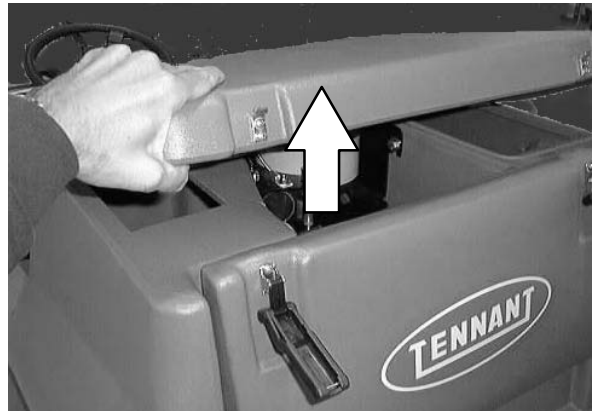

2. Reconnect the vacuum fan exhaust hose to the bottom of the fan outlet port.

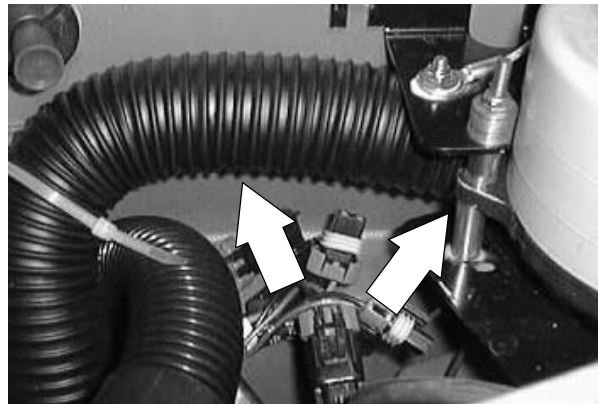

3. Reconnect the plug from the vacuum fan motor into the main electrical harness. See schematic in the ELECTRICAL section.

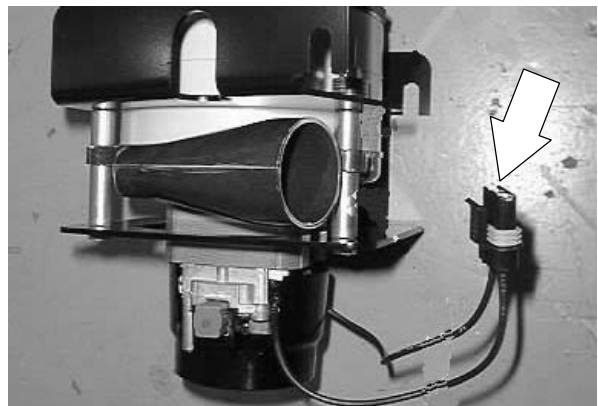

- Drop the vacuum fan assembly straight down into the tank mounting area. Make sure the rubber seal is in place on the outlet of the vacuum housing.

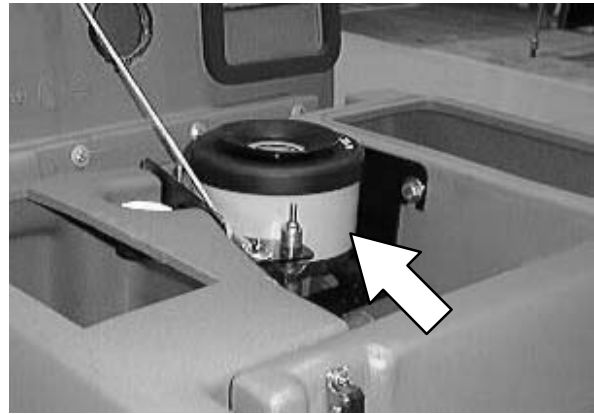

- Reinstall the three screws holding the vacuum fan to the top of the tanks. Tighten to 18 – 24 Nm (15 – 20 ft lb).

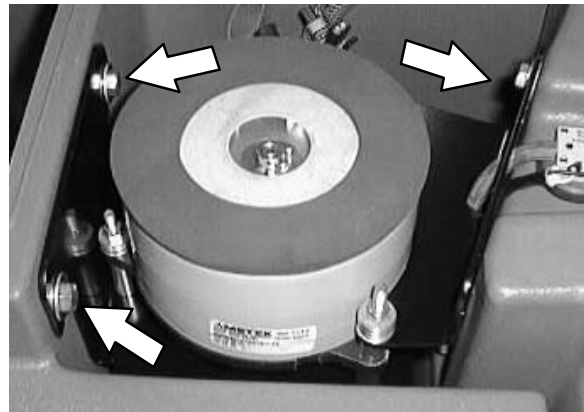

- Close the tank cover and operate the machine. *Make sure the top of the vacuum fan seal contacts the bottom of the tank cover.* Check the vacuum fan for proper operation.

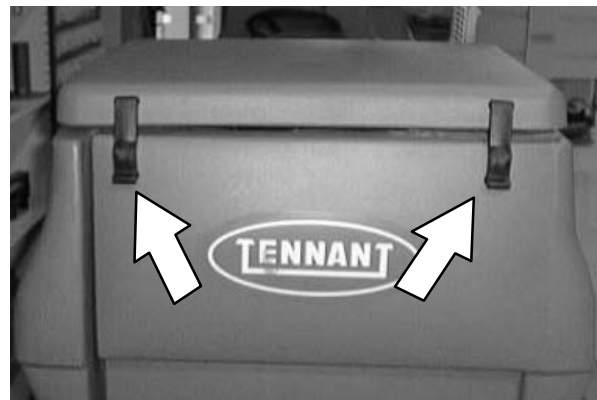

# SCRUBBING

## MACHINE TROUBLESHOOTING

Problem	Cause	Remedy
Trailing water – poor or no water pickup	Worn squeegee blades	Rotate or replace squeegee blades
	Squeegee out of adjustment	Adjust squeegee
	Vacuum hose clogged	Flush vacuum hoses
	Vacuum fan inlet filter dirty or wet	Clean and dry inlet filter
	Debris caught on squeegee	Remove debris
	Vacuum hose to squeegee or recovery tank disconnected or damaged	Reconnect or replace vacuum hose
	Tank cover not completely closed	Check for obstructions
	Torn seals on recovery tank	Replace seals
Vacuum fan will not turn on	Recovery tank full	Drain recovery tank
	Foam filling recovery tank	Empty recovery tank
		Use less or change detergent
		Use a defoamer
Vacuum fan circuit breaker tripped	Reset circuit breaker	
Little or no solution flow to the floor	Solution tank empty	Fill solution tank
	Solution control rod broken or out of adjustment	Replace and/or adjust rod
	Solution flow turned off	Turn solution flow on
	Solution supply lines plugged	Flush solution supply lines
	Solution solenoid clogged or stuck	Clean or replace
	ES™ mode (option): ES™ switch off	Turn ES™ switch on
Poor scrubbing performance	Debris caught on scrub brushes	Remove debris
	Improper detergent or brush used	Check with TENNANT representative for advice
	Worn scrub brush(es)	Replace scrub brush(es)
	Scrub brush motor circuit breaker(s) tripped	Reset circuit breaker(s)
		Reduce scrub brush down pressure
		Uneven brush pressure, level scrub head
		Broken brush drive belts on cylindrical scrub head, replace belt
		Check with TENNANT representative for advice
	Low battery charge	Charge batteries until the charger automatically turns off



	Page		Page
INTRODUCTION .....	4-3	WIRE HARNESS GROUP	
ELECTRICAL SYSTEM .....	4-4	(S/N 7100XXX02700- ) .....	4-80
BATTERIES .....	4-4	WIRE HARNESS GROUP	
TO CHARGE BATTERIES .....	4-5	(S/N 7100XXX02700- ) .....	4-81
TO REPLACE BATTERIES .....	4-7	WIRE HARNESS GROUP	
INSTRUMENT PANEL .....	4-10	(S/N 7100XXX02700- ) .....	4-82
TO REPLACE TOUCH PANEL .....	4-10	WIRE HARNESS GROUP	
CONTROL PANEL .....	4-15	(S/N 7100XXX02700- ) .....	4-83
TO ACCESS CONTROL/INSTRUMENT		WIRE HARNESS GROUP	
PANEL .....	4-15	(S/N 7100XXX00001-02699) .....	4-84
TO REPLACE CIRCUIT BOARD .....	4-18	WIRE HARNESS GROUP	
CIRCUIT BREAKERS .....	4-22	(S/N 7100XXX00001-02699) .....	4-85
RESETABLE CIRCUIT BREAKERS ..	4-22	WIRE HARNESS GROUP	
TO REPLACE CIRCUIT BREAKER ..	4-23	(S/N 7100XXX00001-02699) .....	4-86
FUSES .....	4-26	WIRE HARNESS GROUP	
TO REPLACE FUSE .....	4-26	(S/N 7100XXX00001-02699) .....	4-87
DIRECTIONAL PEDAL .....	4-28	FAST ELECTRICAL SCHEMATIC	
TO REMOVE DIRECTIONAL PEDAL		(S/N 7100XXX01709- ) .....	4-88
ASSEMBLY .....	4-29	OPERATING MODES .....	4-89
TO INSTALL DIRECTIONAL PEDAL		NORMAL MODE .....	4-90
ASSEMBLY .....	4-31	SCRUB BUTTON .....	4-90
TO REPLACE DIRECTIONAL PEDAL		SCRUB PRESSURE	
POTENTIOMETER .....	4-33	DOWNSHIFT FEATURE .....	4-91
TO SET POTENTIOMETER		SQUEEGEE BUTTON .....	4-91
NEUTRAL .....	4-36	ES™ BUTTON .....	4-92
TO REPLACE MOTOR		OVERFLOW FLOAT SWITCH .....	4-92
CONTROLLER .....	4-39	SOLUTION LOW FLOAT SWITCH .....	4-92
ELECTRIC MOTORS .....	4-42	BATTERY GAUGE .....	4-93
TO REPLACE DRIVE MOTOR		HOUR METER .....	4-93
ASSEMBLY .....	4-42	INTERLOCKS .....	4-94
TO REPLACE DISC SCRUB HEAD		SELF TEST MODE .....	4-96
BRUSH MOTOR .....	4-43	SELF TEST ERROR CODES .....	4-98
TO REPLACE CYLINDRICAL SCRUB		ACTUATOR GROUP,	
HEAD BRUSH MOTOR .....	4-47	SQUEEGEE BUTTON PRESSED .	4-98
LIFT ACTUATORS .....	4-52	BRUSH MOTOR GROUP,	
TO REPLACE SCRUB HEAD LIFT		SCRUB BUTTON PRESSED .....	4-98
ACTUATOR .....	4-52	ACCESSORY OUTPUT GROUP	
TO REPLACE REAR SQUEEGEE LIFT		SQUEEGEE AND SCRUB BUTTONS	
ACTUATOR .....	4-56	PRESSED .....	4-98
ES™ PUMP .....	4-61	NO BUTTONS PRESSED .....	4-99
TO REPLACE ES™ PUMP .....	4-61	ES™ OUTPUT GROUP,	
SOLUTION SOLENOID VALVE .....	4-65	ES™ BUTTON PRESSED .....	4-99
TO REPLACE SOLUTION SOLENOID		MANUAL MODE .....	4-100
VALVE .....	4-65	SCRUB BUTTON .....	4-100
VACUUM FAN .....	4-68	SQUEEGEE BUTTON .....	4-101
TO REPLACE VACUUM FAN .....	4-68	ES™ BUTTON	
TO REMOVE ROLLOUT BATTERY ..	4-70	(TENNANT MACHINES ONLY) .	4-101
ELECTRICAL SCHEMATIC		INTERLOCKS .....	4-102
(S/N 7100XXX02700- ) .....	4-74	SCRUB BRUSH OPERATION .....	4-102
ELECTRICAL SCHEMATIC		SQUEEGEE AND VACUUM	
(S/N 7100XXX02700- ) .....	4-75	FAN OPERATION .....	4-102
ELECTRICAL SCHEMATIC		ES™ PUMP OPERATION .....	4-103
(S/N 7100XXX02700- ) .....	4-76	INPUT DISPLAY MODE .....	4-104
ELECTRICAL SCHEMATIC		RESTRICTED DOWN	
(S/N 7100XXX00001-02699) .....	4-77	PRESSURE MODE .....	4-106
ELECTRICAL SCHEMATIC		SOFTWARE DATE DISPLAY MODE ..	4-107
(S/N 7100XXX00001-02699) .....	4-78	CIRCUIT BOARD PIN FUNCTIONS ..	4-108
ELECTRICAL SCHEMATIC		SCRUB BRUSH MOTOR CURRENT DRAW	
(S/N 7100xxx00001-02699) .....	4-79	SPECIFICATIONS: .....	4-108

	Page
CURTIS® PROPEL CONTROL	
LED OPERATION .....	4-108
CURTIS® PROPEL CONTROLLER	
TROUBLESHOOTING .....	4-109
ES™ SYSTEM .....	4-111
(NOTE: ONCE THE ES PUMP IS TURNED ON, IT WILL KEEP RUNNING UNTIL SWITCH S6 OPENS FOR 30 SECONDS) .....	4-111
ES™ SYSTEM .....	4-112
HORN .....	4-113
SHROUD LIGHT/HEAD	
LIGHTS .....	4-115
PROPEL CONTROLLER .....	4-117
PROPEL CONTROLLER .....	4-118
POWER WAND &	
BACKUP ALARM .....	4-119
POWER-UP TESTING .....	4-121
SCRUB SYSTEM .....	4-123
SCRUB SYSTEM .....	4-125
SOLUTION EMPTY .....	4-127
SOLUTION VALVE .....	4-129
SQUEEGEE SYSTEM .....	4-131
TOUCH PANEL .....	4-133
VACUUM FAN .....	4-135
VACUUM FAN .....	4-136

**INTRODUCTION**

The 7100 electrical system consists of the batteries, instrument panel, drive motor, switches, relays, and circuit breakers.

## ELECTRICAL SYSTEM

---

The model 7100 is a battery powered, all electric machine. The batteries are used to power the front drive motor, vacuum fan motor, scrub brush motors, and lift actuators.

## BATTERIES

---

The batteries are unique in that they hold their power for long periods of time. The lifetime of the batteries is limited by the number of charges the batteries receive. To get the most life from the batteries, charge them when the last battery discharge indicator segment flashes (20% charge left). Use an automatic charger with the proper rating for the batteries.

Periodically clean the top surface of the batteries and the terminals, and check for loose connections. Use a strong solution of baking soda and water. Brush the solution sparingly over the battery tops, terminals, and cable clamps. Do not allow any baking soda solution to enter the batteries. Use a wire brush to clean the terminal posts and the cable connectors. After cleaning, apply a coating of clear battery post protectant to the terminals and the cable connectors. Keep the tops of the batteries clean and dry.

Keep all metallic objects off the top of the batteries, which may cause a short circuit. Replace any worn or damaged wires.

Check the electrolyte level in each battery after charging, and after every 50 hours of operation. Never add acid to the batteries, only distilled water. Always keep the battery caps on, except when adding water or taking hydrometer readings.

Measuring the specific gravity, using a hydrometer, is a way to determine the charge level and condition of the batteries. If one or more of the battery cells test lower than the other battery cells (0.050 or more), the cell is damaged, shorted, or is about to fail.

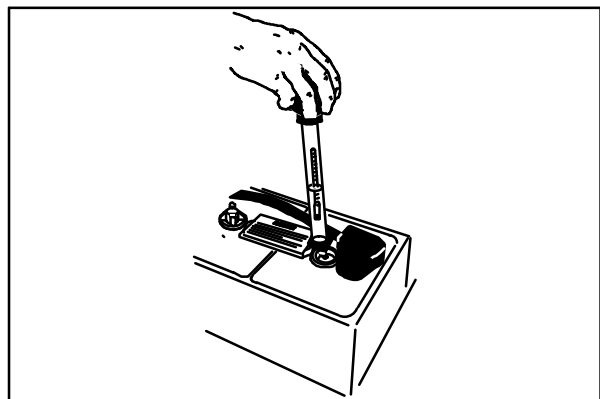

04380

*NOTE: Do not take readings immediately after adding distilled water. If the water and acid are not thoroughly mixed, the readings may not be accurate. Check the hydrometer readings against the following chart to determine the remaining battery charge level:*

Spec. Gravity at 27° C (80° F)	
Charge Level	220 AH Battery
100 %	1.265
75 %	1.223
50 %	1.185
25 %	1.148
Discharged	1.110

*NOTE: If the readings are taken when the battery electrolyte is any temperature other than shown, the reading must be temperature corrected. Add or subtract to the specific gravity reading 0.004, 4 points, for each 6° C (10° F) above or below 25° C (77° F).*

### TO CHARGE BATTERIES

1. Drive the machine to a flat, dry surface in a well-ventilated area.
2. Stop the machine, set the parking brake and turn the machine power off.

**FOR SAFETY: Before leaving or servicing machine, stop on level surface, set parking brake, turn off machine, and remove key.**

3. Open the seat support.
4. Check the water level in all the battery cells. If the level is low, add just enough distilled water to cover the plates. **DO NOT OVERFILL.** The batteries can overflow during charging due to expansion.

*NOTE: Make sure the battery caps are in place while charging.*

**FOR SAFETY: When maintaining or servicing machine, avoid contact with battery acid.**

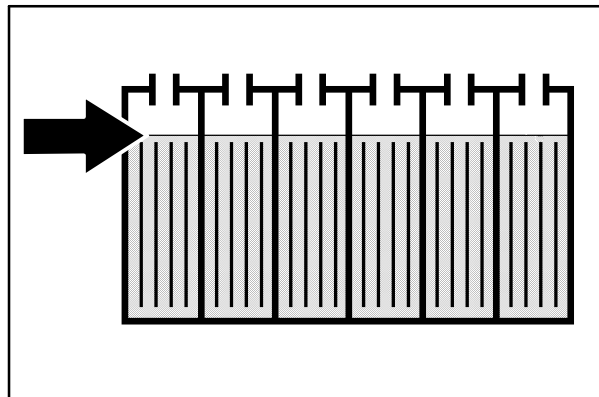

## ELECTRICAL

5. Plug the connector from the batteries into the battery charger connector.

**⚠ WARNING: Batteries emit hydrogen gas. Explosion or fire can result. Keep sparks and open flame away. Keep covers open when charging.**

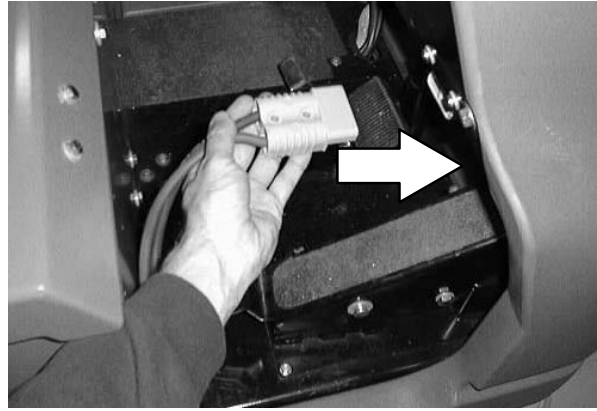

*NOTE: Plug the charger connector into connector that runs to the batteries. Do not plug charger into mounted connector. Damage may occur to the machine.*

*NOTE: If the red "ABNORMAL CYCLE" lamp lights when the batteries are plugged into the TENNANT charger, this indicates that something is wrong with the battery. The charger can not charge the battery when this happens.*

6. The Tennant charger will start automatically. When the batteries are fully charged, the Tennant charger will automatically turn off.

*NOTE: Use a charger with the proper rating for the batteries to prevent damage to the batteries or reduce the battery life.*

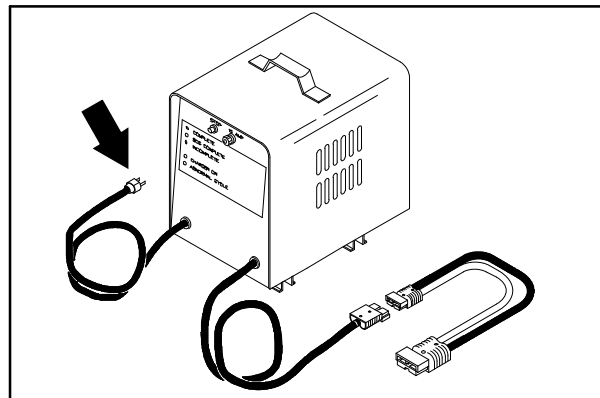

*NOTE: If the charger needs to be disconnected from the machine before the batteries are fully charged and the charger has not automatically shut off, turn off the charger before disconnecting it.*

7. After the charger has turned off, unplug the charger connector from the battery connector on the machine.
8. Reconnect the battery connector to the machine connector.
9. Check the electrolyte level in each battery cell. Add just enough distilled water to bring the electrolyte level up to the bottom of the fill rings.

**FOR SAFETY: When maintaining or servicing machine, avoid contact with battery acid.**

10. Close the seat support.



**TO REPLACE BATTERIES**

**FOR SAFETY: Before Leaving Or Servicing Machine; Stop On Level Surface, Set Parking Brake.**

1. Open the seat support and engage the prop rod.

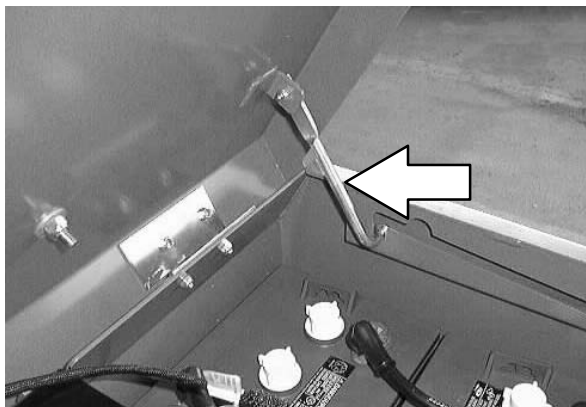

2. Disconnect the machine batteries.

**FOR SAFETY: Disconnect Battery Connections Before Working On machine.**

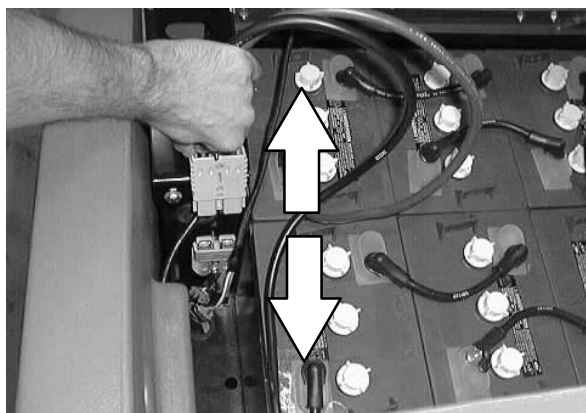

3. Remove the five small battery cables from the batteries.

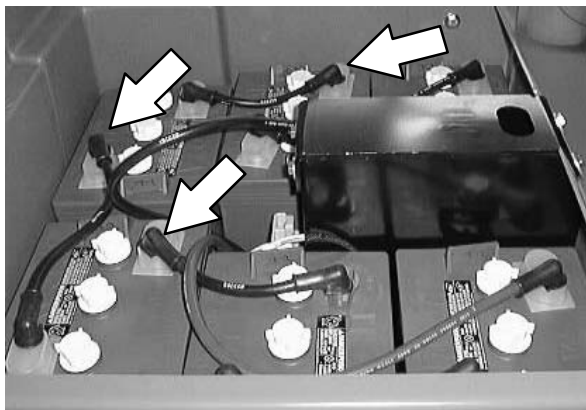

## ELECTRICAL

4. Disconnect the connector assembly from the batteries.

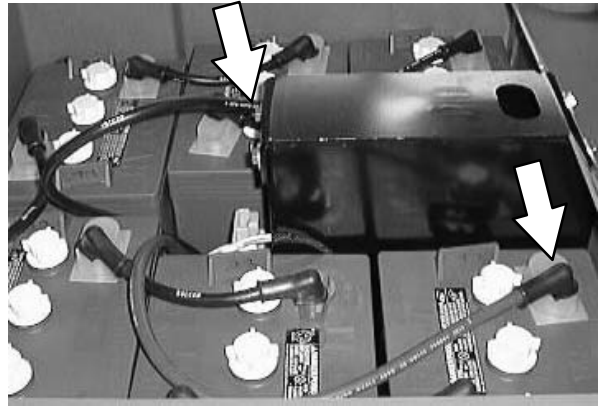

5. Remove the batteries one at a time. *Note the orientation of the battery neg and pos.*

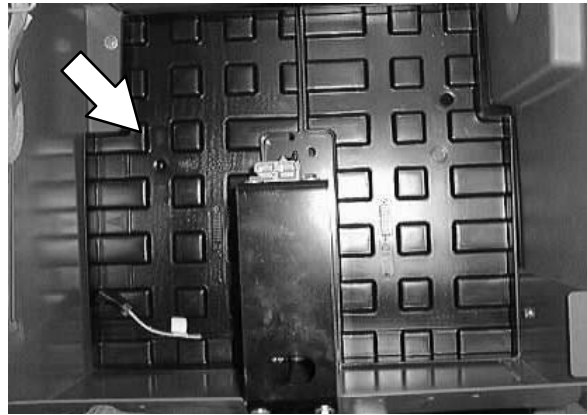

6. Install the new batteries into the battery tray. *Note the orientation of the battery neg and pos.*

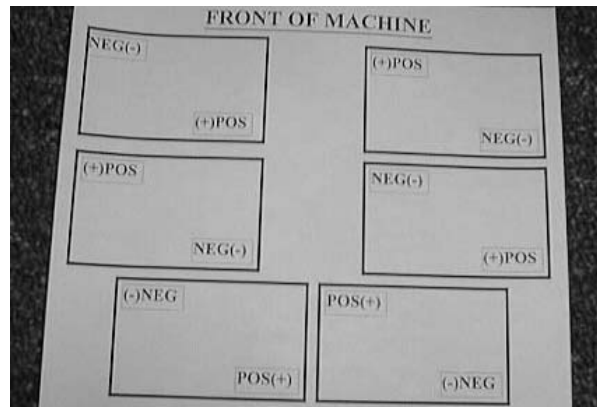

7. Reinstall the five small battery cables onto the new batteries.

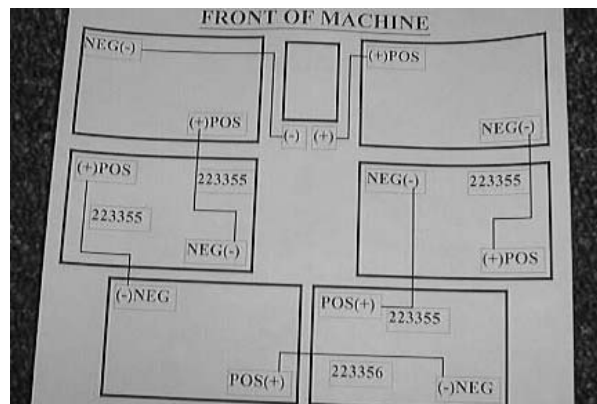



8. Reinstall the connector assembly onto the batteries.

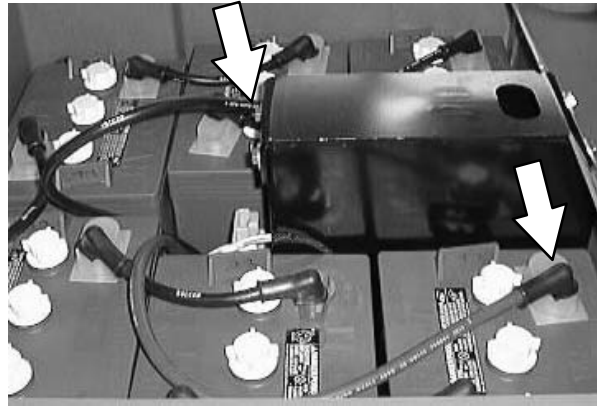

9. Reconnect the battery connect to the machine connector.

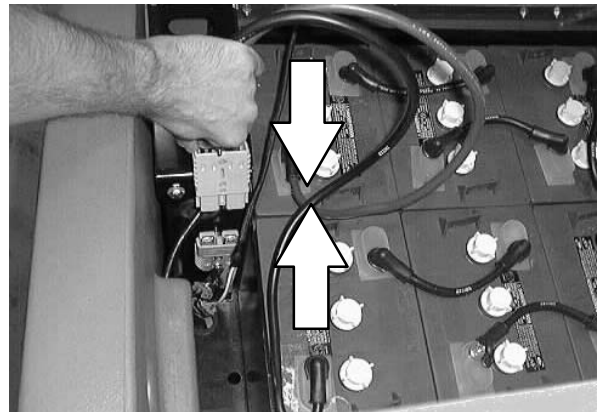

10. Disengage the prop rod and lower the seat support.



11. Start the machine and check the new batteries for proper operation.

## INSTRUMENT PANEL

The instrument panel consists of a touch panel, circuit board, switches, and key switch. The touch panel controls various machine functions. The indicator lights keep the operator informed on machine performance.



### TO REPLACE TOUCH PANEL

**FOR SAFETY: Before Leaving Or Servicing Machine; Stop On Level Surface, Set Parking Brake.**

1. Open the control panel. See TO ACCESS CONTROL PANEL instructions. *Make sure to disconnect the machine batteries.*

**FOR SAFETY: Disconnect Battery Connections Before Working On machine.**

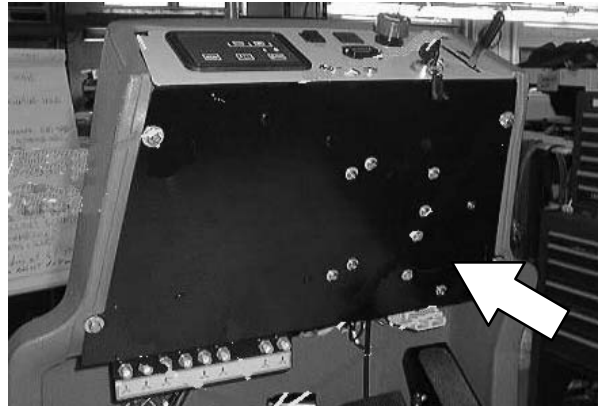

2. Locate the circuit board cover on the inside, front wall of the control panel.

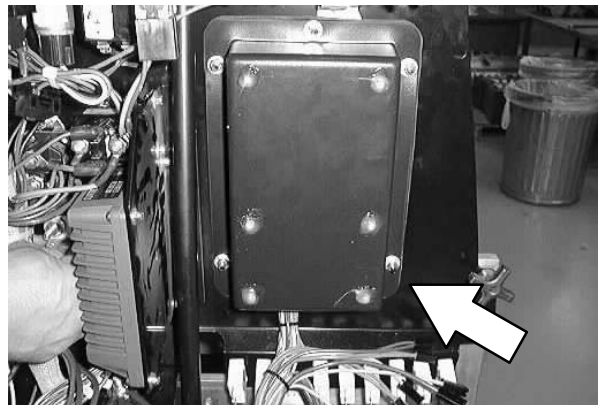

3. Remove the six nuts holding the circuit board cover onto the frame.

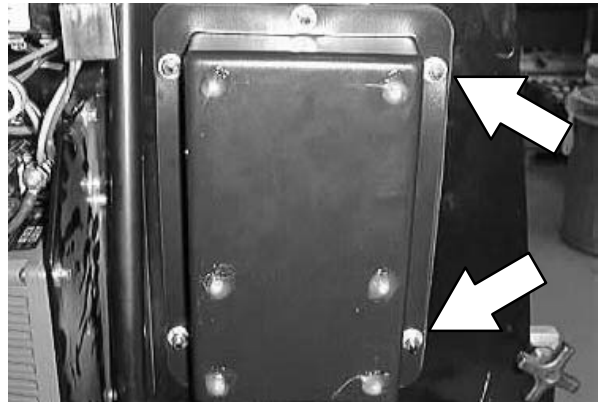

4. Pull the circuit board cover back to access the circuit board.

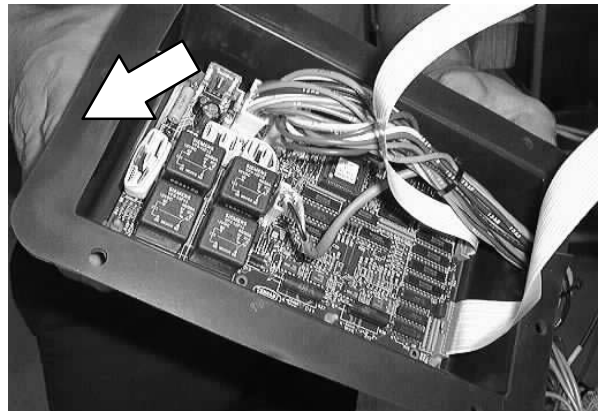

5. Un-plug the ribbon cable from the circuit board.

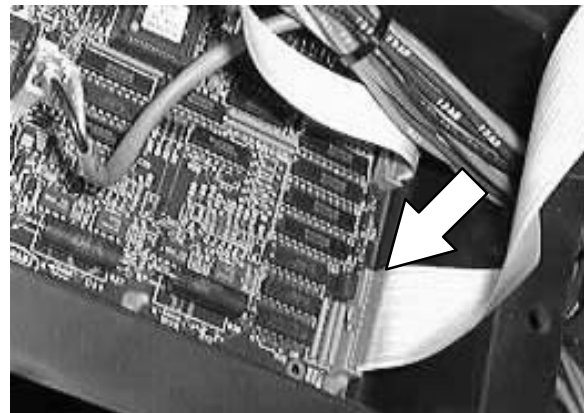

6. Locate the six touch panel lock clips on the under side of the dash panel. Remove the lock clips.



## ELECTRICAL

7. Pull the touch panel bezel up and remove from the machine.

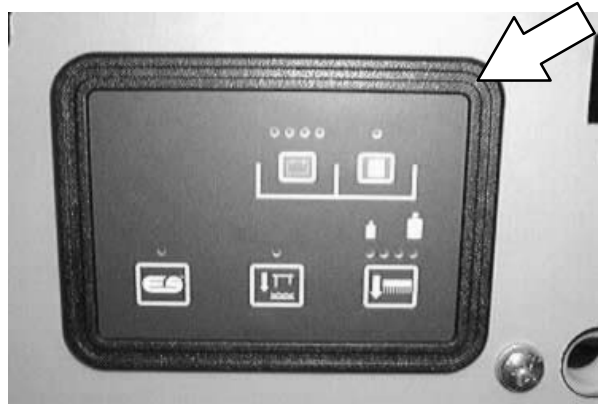

8. Remove the touch panel from the machine. *Be careful when removing the ribbon cables from the slot in the dash panel.*

9. Position the new touch panel on the machine. Route the ribbon cable through the slot in the dash panel.



10. Place the touch panel bezel over the touch panel. Line up the posts on the bezel with the mount holes in the dash panel.

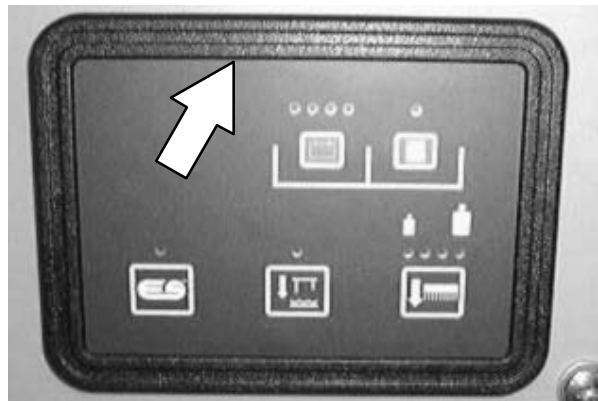

11. Install the six lock clips on the bezel posts.

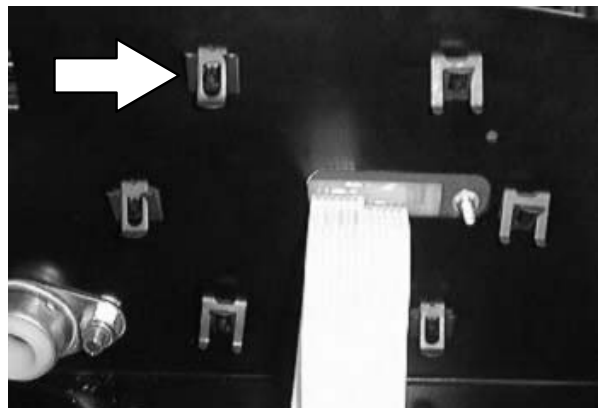

12. Connect the ribbon cable to the circuit board.

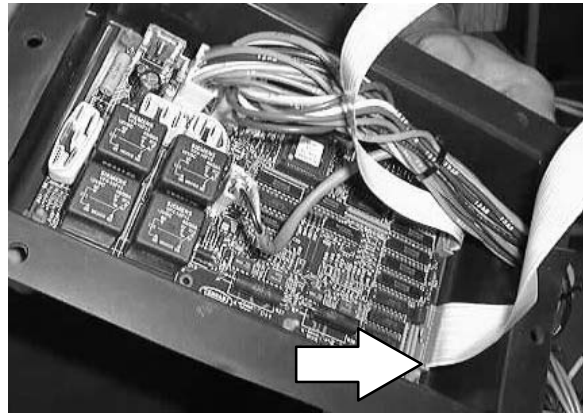

13. Position the circuit board cover back to the inside, front wall of the control panel.

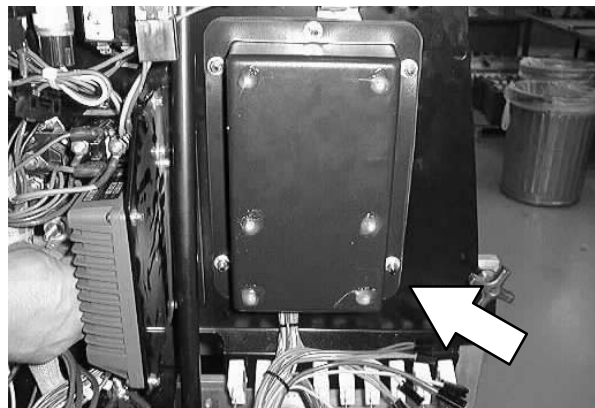

14. Reinstall the six nuts on the circuit breaker cover. Hand tighten lightly.

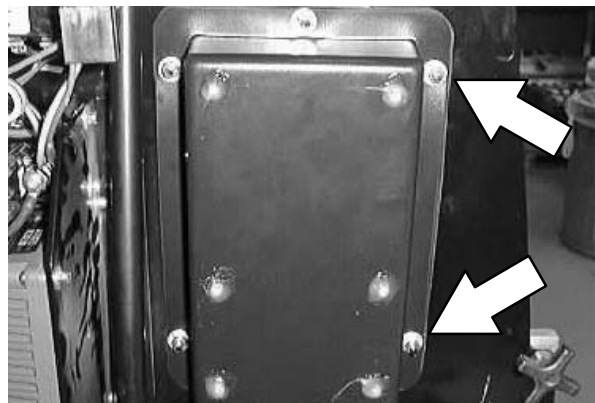

15. Pivot the control panel back in position. Reinstall the four screws and tighten to 18 – 24 Nm (15 – 20 ft lb).

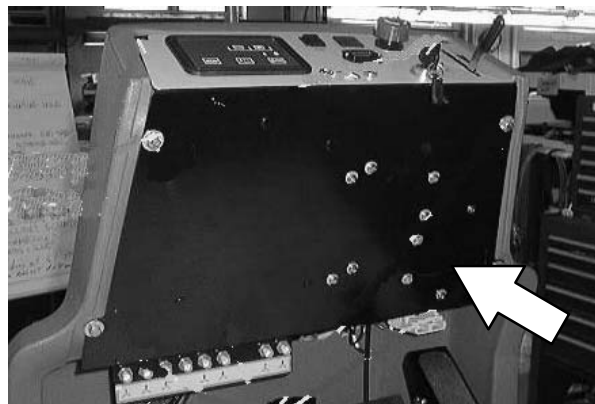

## ELECTRICAL

16. Open the operator seat and reconnect the battery connector at the front of the solution tank.

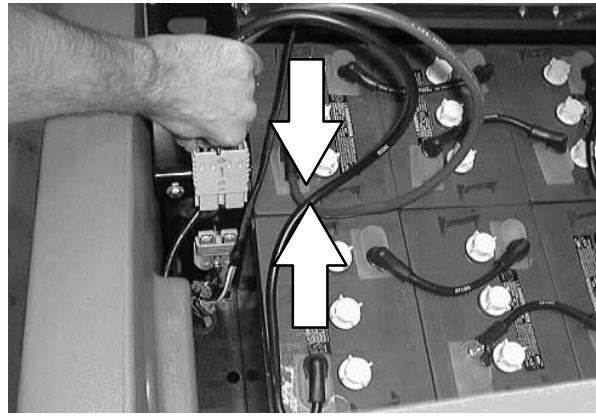

17. Close the seat support. Start the machine and check for proper operation.



## CONTROL PANEL

The control panel houses the directional controller, relays, contactors, circuit breakers, and fuses. These components can be accessed by pivoting the control panel mount plate down against the seat support.

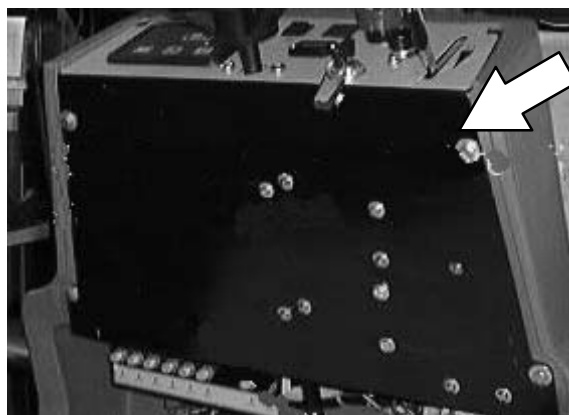

### TO ACCESS CONTROL/INSTRUMENT PANEL

**FOR SAFETY: Before Leaving Or Servicing Machine; Stop On Level Surface, Set Parking Brake.**

1. Lift the operator seat to access the batteries. The support arm automatically engages when the seat is lifted all the way up.

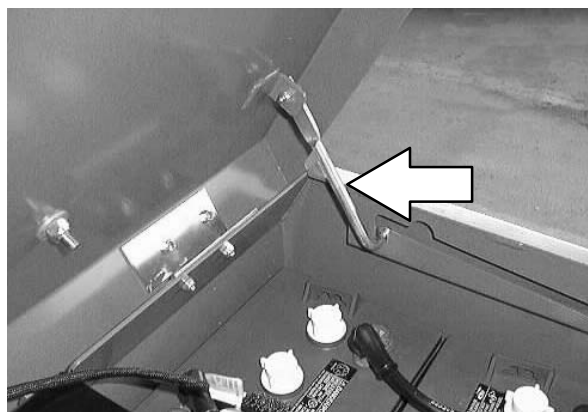

2. Disconnect the battery connector from the machine.

**FOR SAFETY: Disconnect Battery Connections Before Working On machine.**

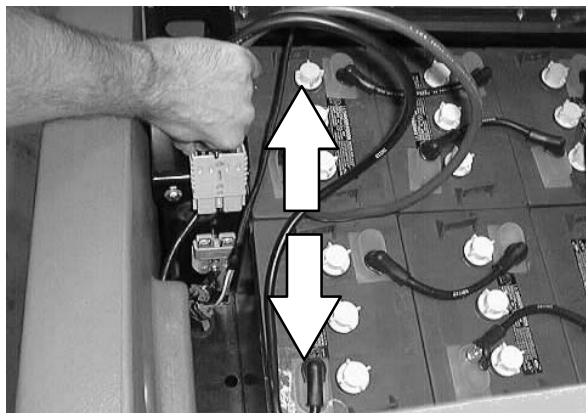

3. Lower the seat support.



4. Remove the two screws at the top of the instrument panel mount plate and the four screws at the sides of the control panel plate.

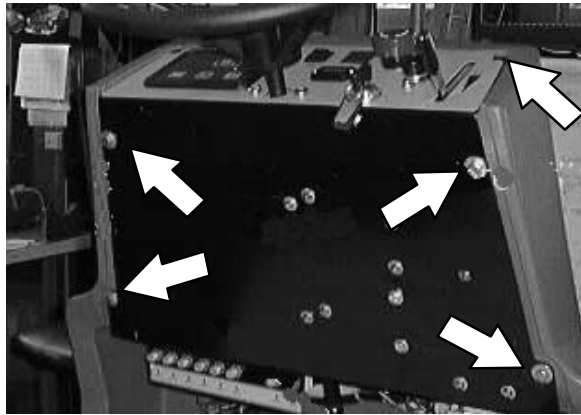

5. Pivot the control panel plate and steering wheel down until it is resting against the seat support.

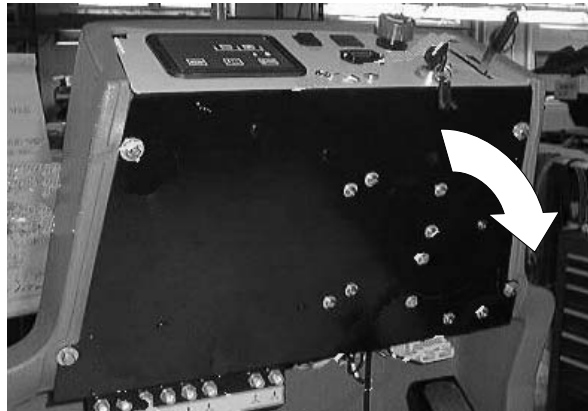

6. Make any necessary repairs to the electrical components.

7. Pivot the control panel plate and steering wheel up until it is positioned into the front shroud.

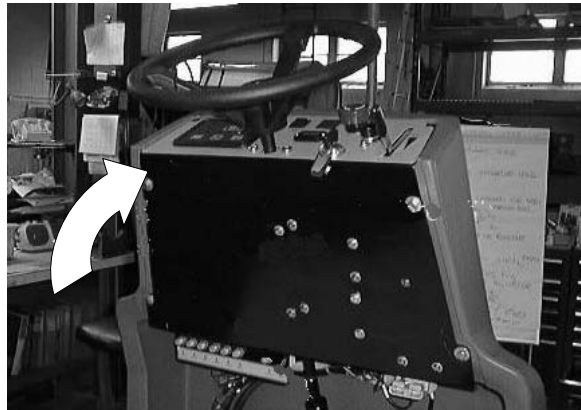



8. Reinstall the two screws at the top of the instrument panel mount plate and the four screws at the sides of the control panel plate.

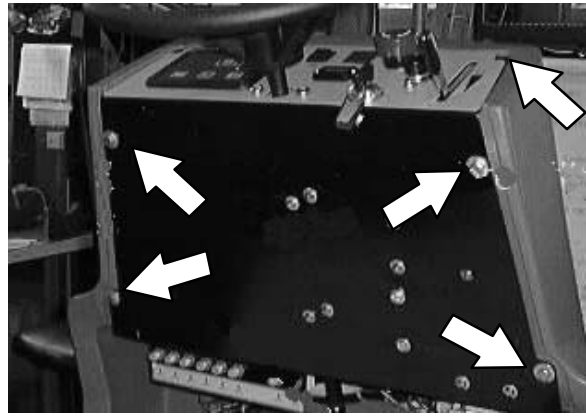

9. Open the operator seat and reconnect the battery connector at the front of the solution tank.

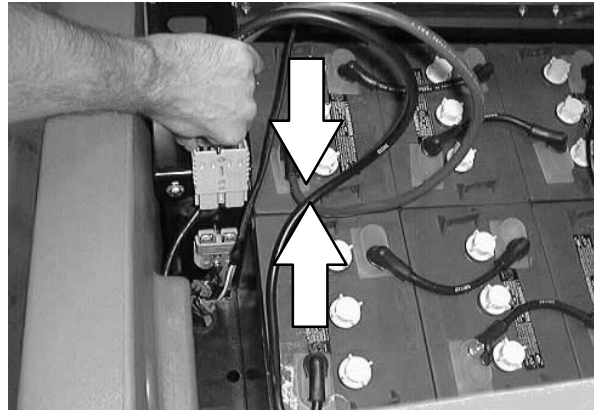

10. Close the seat support. Start the machine and check for proper operation.



## ELECTRICAL

### TO REPLACE CIRCUIT BOARD

**FOR SAFETY: Before Leaving Or Servicing Machine; Stop On Level Surface, Set Parking Brake.**

1. Open the control panel. See TO ACCESS CONTROL/INSTRUMENT PANEL instructions. *Make sure to disconnect the machine batteries.*

**FOR SAFETY: Disconnect Battery Connections Before Working On machine.**

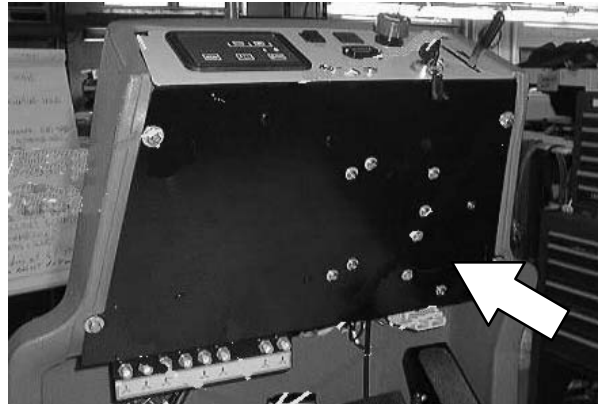

2. Locate the circuit board cover on the inside, front wall of the control panel.

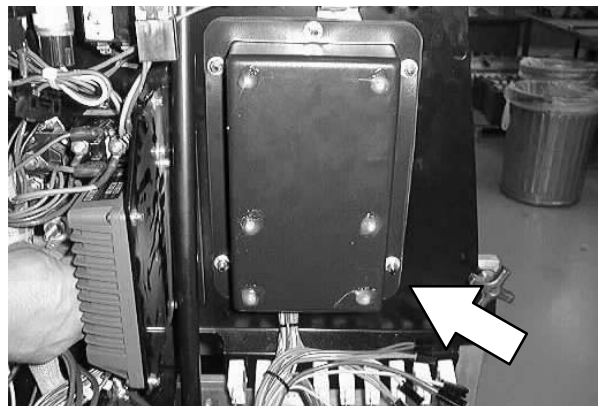

3. Remove the six nuts holding the circuit board cover onto the frame.

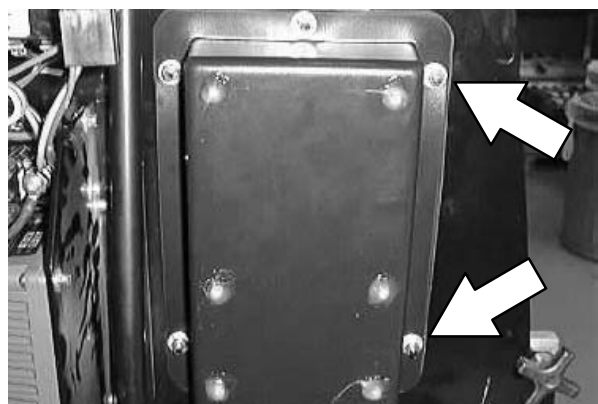

4. Pull the circuit board cover back to access the circuit board.

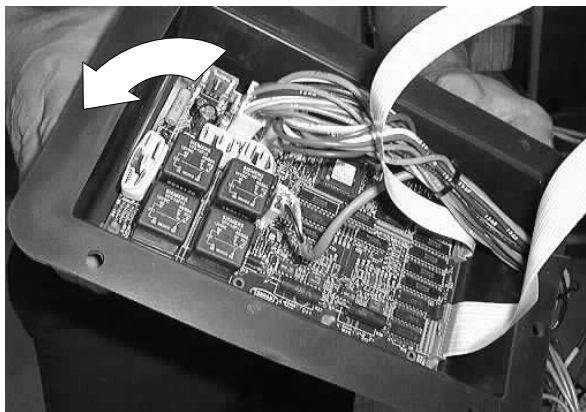

5. Un-plug the ribbon cable from the circuit board.

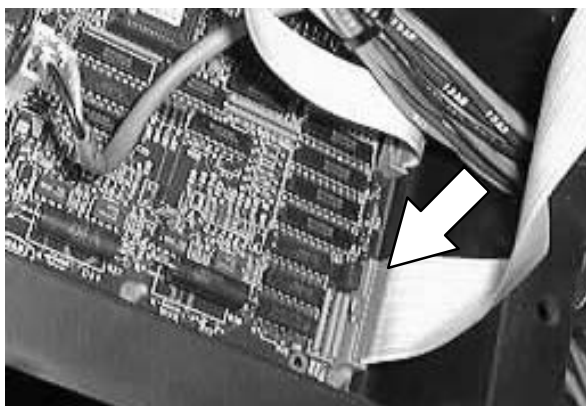

6. Un-plug the three wire connectors from the circuit board.

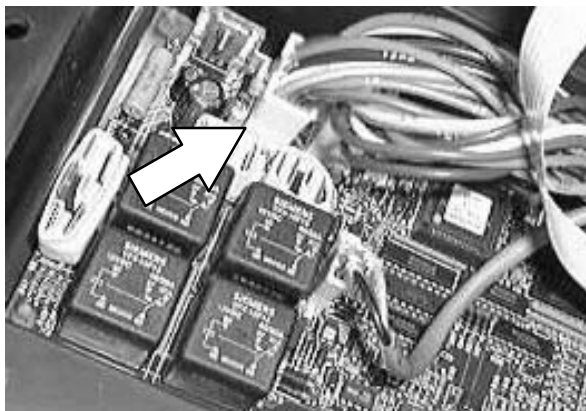

7. Pop the circuit board off the six plastic stand-offs. Remove the circuit board from the machine. Note the orientation of the circuit board.

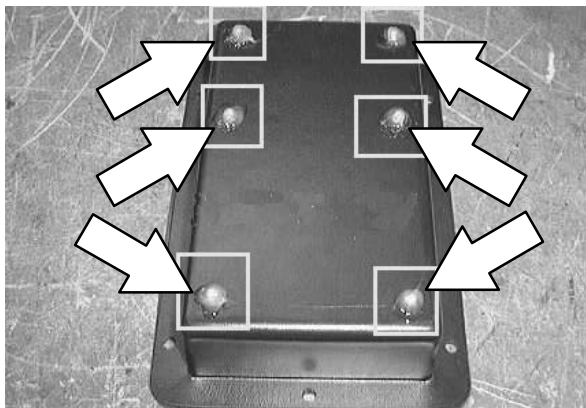

## ELECTRICAL

8. Position the new circuit board onto the six plastic stand-offs. Gently push the board down until the stand-off snaps in place.

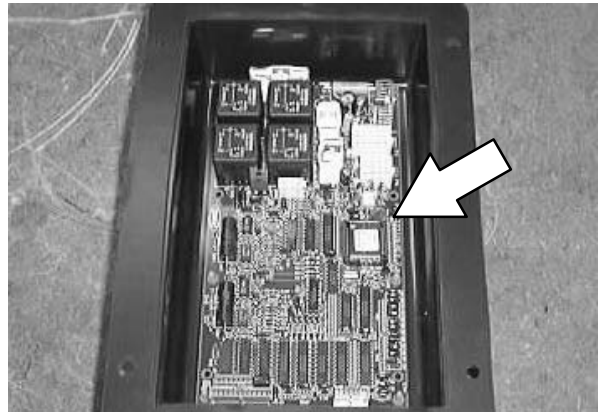

9. Reconnect the three wire connectors and two ribbon cables to the new circuit board. See schematic in this section.

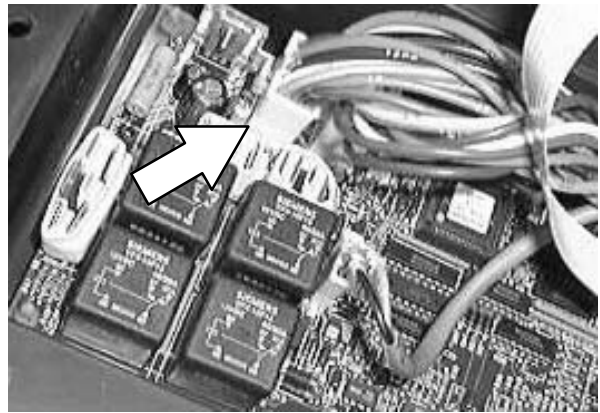

10. Reconnect the ribbon cable to the new circuit board.

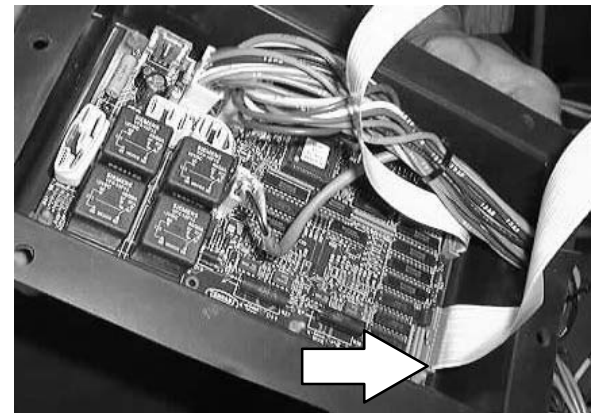

11. Position the circuit board cover back to the inside, front wall of the control panel.

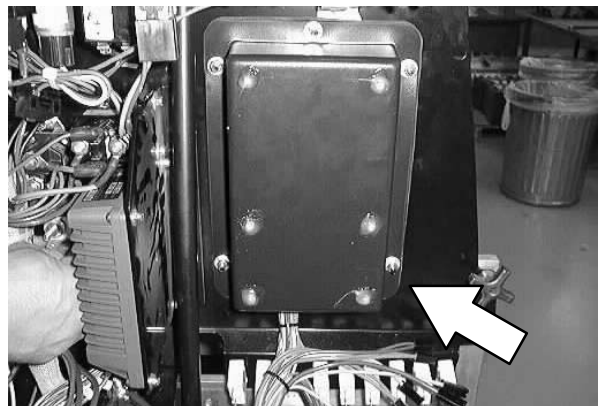

12. Reinstall the six nuts on the circuit breaker cover. Hand tighten lightly.

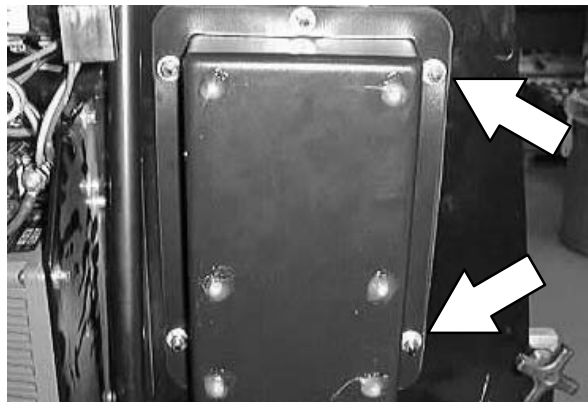

13. Pivot the control panel back in position. Reinstall the six screws and tighten. See TO ACCESS CONTROL/INSTRUMENT PANEL instructions.

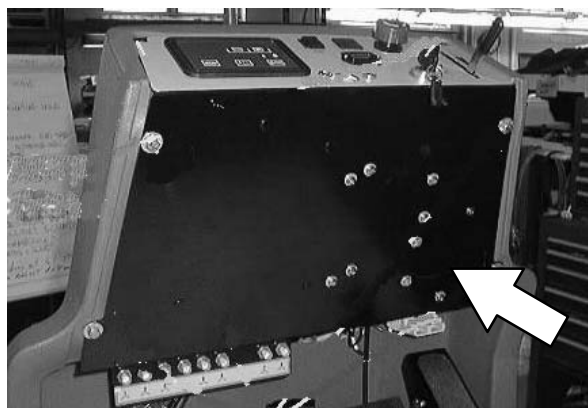

14. Open the operator seat and reconnect the battery connector at the front of the solution tank.

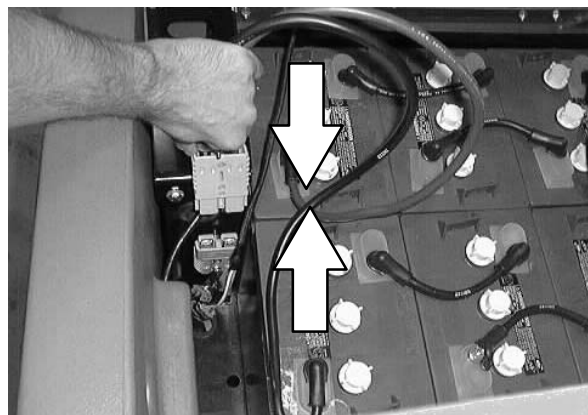

15. Close the seat support. Start the machine and check for proper operation.

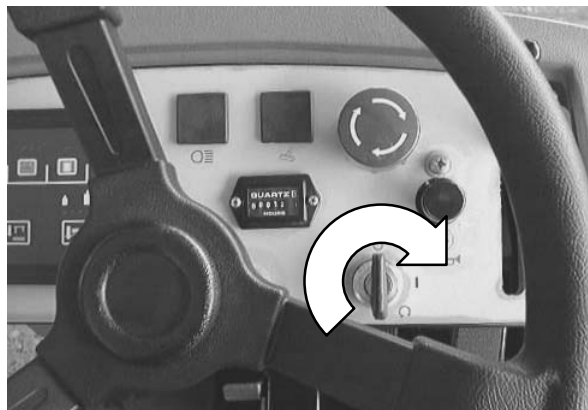

## CIRCUIT BREAKERS

### RESETABLE CIRCUIT BREAKERS

Circuit breakers are resettable electrical circuit protection devices designed to stop the flow of current in the event of a circuit overload. Once a circuit breaker is tripped, reset it manually by pressing the reset button after the breaker has cooled down.

If the overload that caused the circuit breaker to trip is still present, the circuit breaker will continue to stop current flow until the problem is corrected.

The circuit breakers are located at the lower, left corner of the control panel.

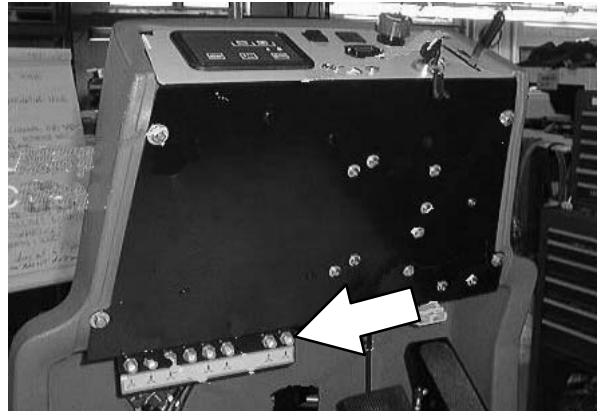

The chart below shows the circuit breakers and the electrical components they protect.

<b>Circuit Breaker</b>	<b>Rating</b>	<b>Circuit Protected</b>
CB1	2.5 A	Machine power
CB2	2.5 A	Lights
CB3	10 A	Horn
CB4	10 A	Power wand/ Back up alarm
CB5	10 A	Control panel
CB6	20 A	Vacuum Fan (single)
CB6	40 A	Vacuum Fan (dual)
CB7	10 A	ES System (option) FaST System (option)
CB8	25 A	Left Brush Motor
CB9	25 A	Right Brush Motor
CB10	2.5 A	ec-H2O (option)
CB11	2.5 A	ec-H2O (option)

**TO REPLACE CIRCUIT BREAKER**

**FOR SAFETY: Before Leaving Or Servicing Machine; Stop On Level Surface, Set Parking Brake.**

1. Lift the operator seat to access the batteries. The support arm automatically engages when the seat is lifted all the way up.

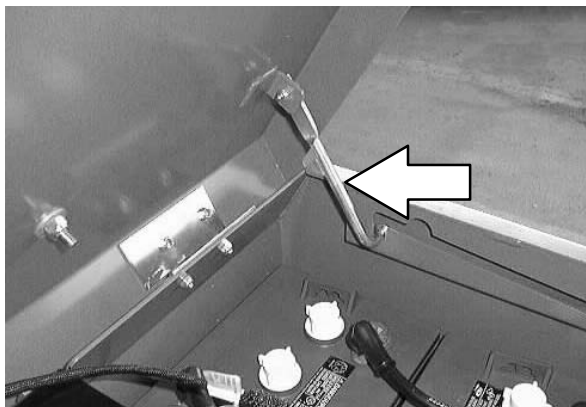

2. Disconnect the battery connector from the machine.

**FOR SAFETY: Disconnect Battery Connections Before Working On machine.**

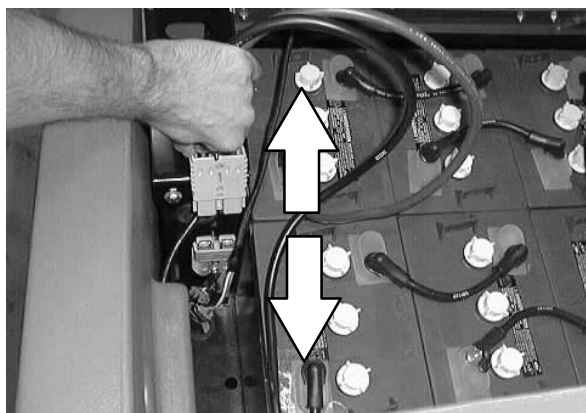

3. Locate the circuit breakers on the lower, left corner of the control panel.

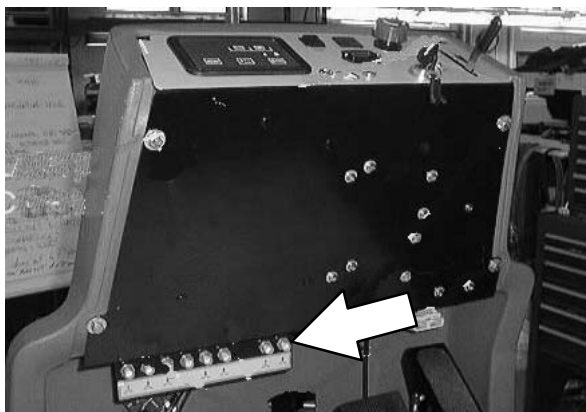

## ELECTRICAL

4. Use the circuit breaker chart to locate the circuit breaker that needs to be changed.

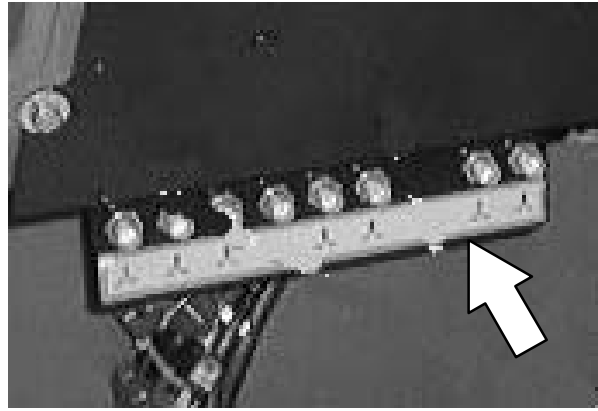

5. Disconnect the wires from the back of circuit breaker.

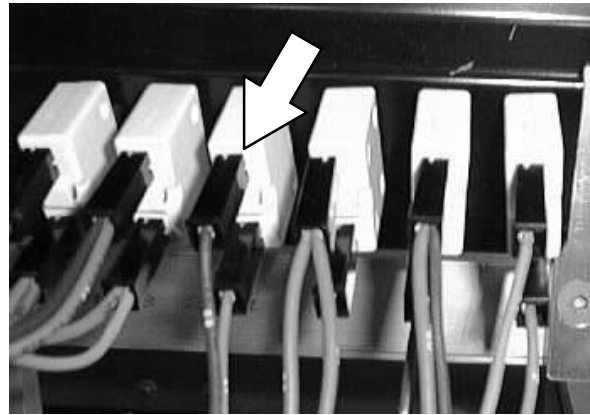

6. Remove the nut/boot from the front of the circuit breaker.

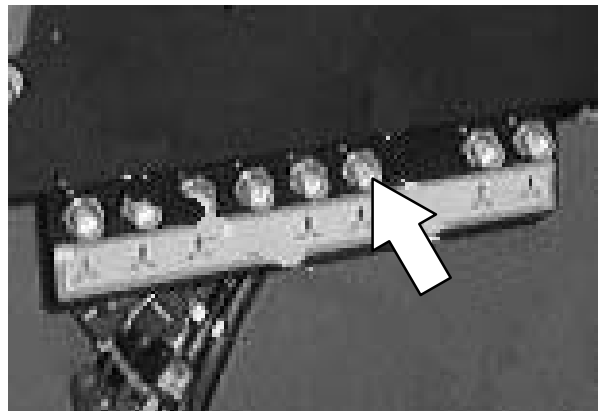

7. Push the circuit breaker out of the mount hole from the back of panel.

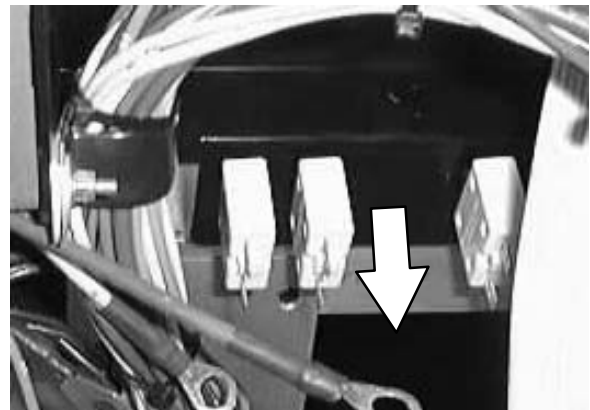



8. Position the new circuit breaker in the mount hole.

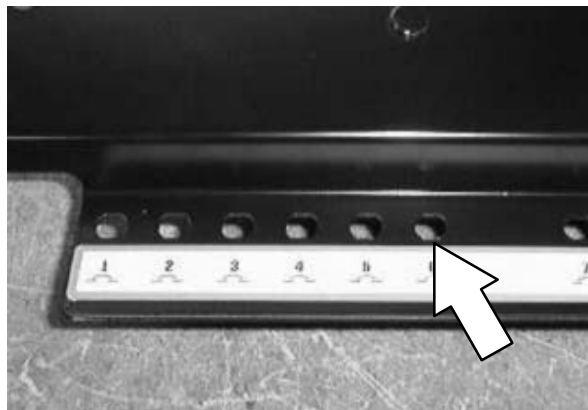

9. Install the nut/boot onto the new circuit breaker.

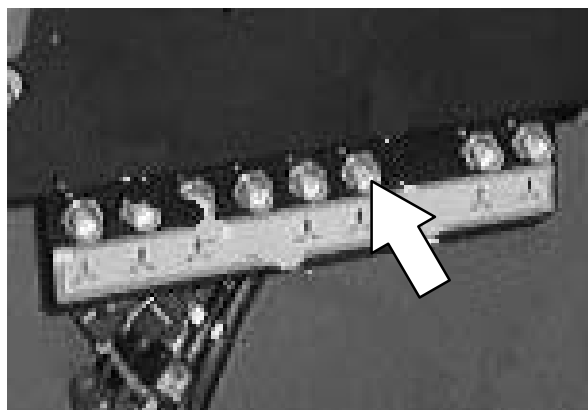

10. Reconnect the wires to the back of the new circuit breaker. See the schematic in this section.

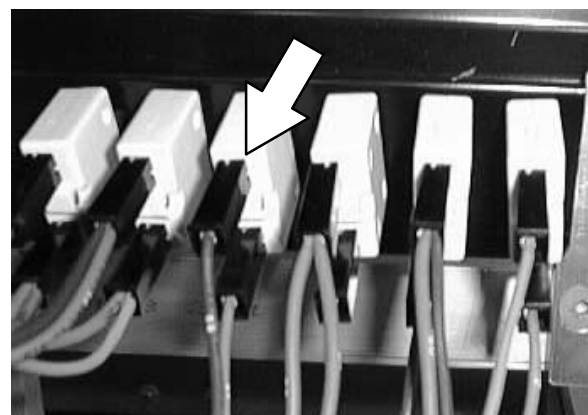

11. Lift the operator seat and reconnect the battery connector at the front of the solution tank.

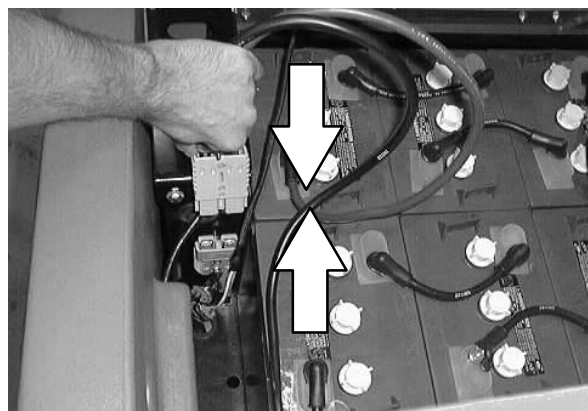

12. Close the seat support. Start the machine and check for proper operation.

# ELECTRICAL

## FUSES

The fuse is a one-time protection device designed to stop the flow of current in the event of a circuit overload.

*NOTE: Always replace the fuse with a fuse of the same amperage.*

The fuse is located behind the operator console. Access the fuse by lowering the operator console.

Fuse	Rating	Circuit Protected
FU-1	40 A	Propelling

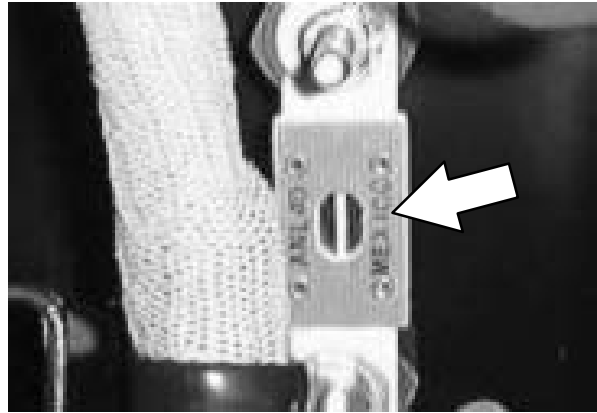

## TO REPLACE FUSE

**FOR SAFETY: Before Leaving Or Servicing Machine; Stop On Level Surface, Set Parking Brake.**

1. Open the control panel. See TO ACCESS CONTROL/INSTRUMENT PANEL instructions in this section.

**FOR SAFETY: Disconnect Battery Connections Before Working On machine.**

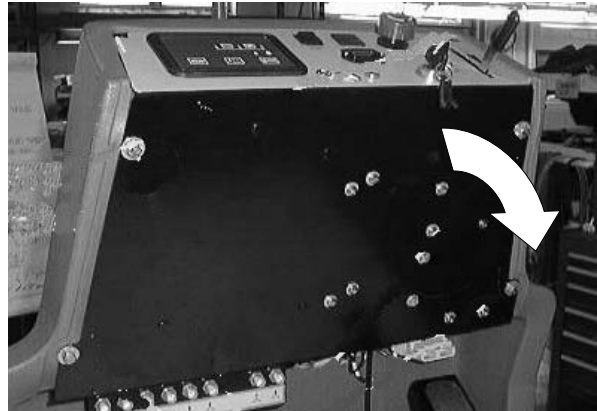

2. Locate the electrical fuse on the bottom, left side of the control panel.

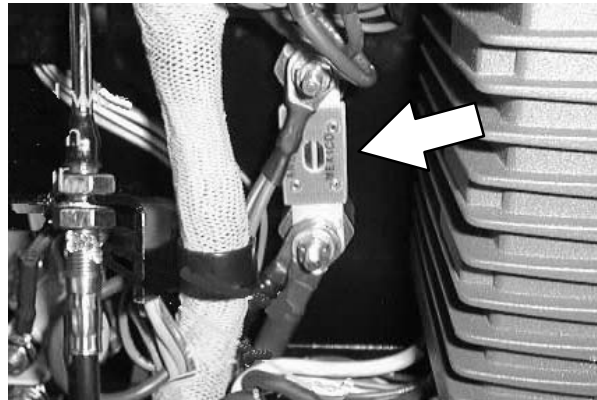

- loosen both bolts holding the two power cables to the top and bottom of the fuse and red stand-offs.
- The fuse has slots on the top and bottom. Slide the fuse up and to the side and remove.

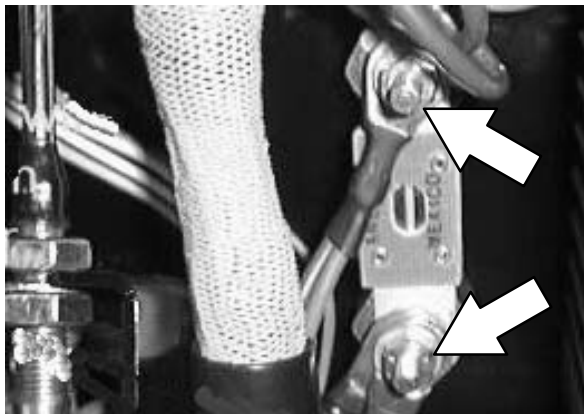

- Position the new fuse on the two red stand-offs, under the two bolts and power cables. Hand tighten the hardware. See the schematic in this section.

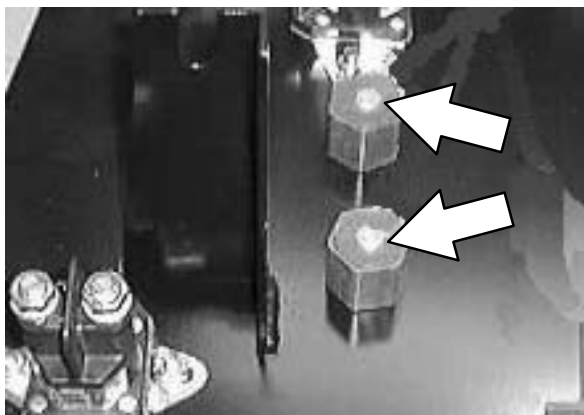

- Pivot the control panel back in position. Reinstall the six screws and tighten to 18 – 24 Nm (15 – 20 ft lb).

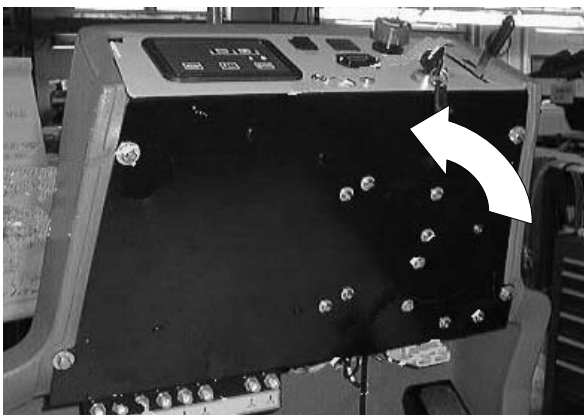

- Lift the operator seat and reconnect the battery connector at the front of the solution tank.

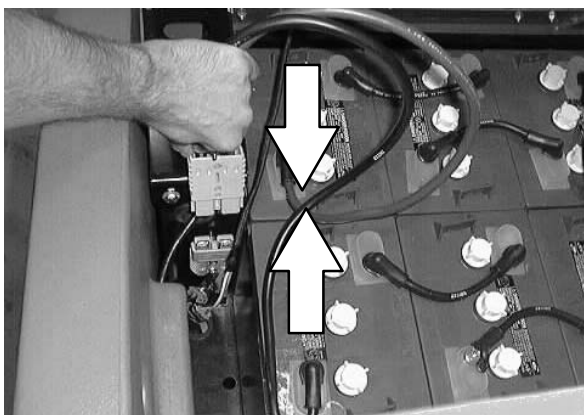

- Start the machine and check for proper operation.

## DIRECTIONAL PEDAL

The directional pedal controls the machine's direction of travel and propelling speed. The machine's speed is controlled by the amount of pressure placed on the pedal; the farther the pedal is pressed, the faster the machine will travel.

When the machine is moving forward and the directional pedal is reversed, the machine will coast for a short distance before changing direction. Use the brake pedal to stop the machine.

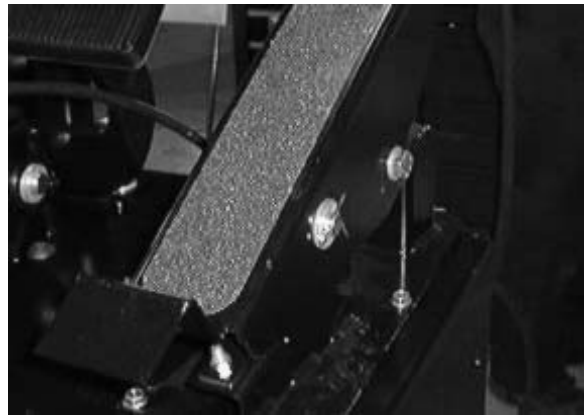

**Forward:** Press the top of the directional pedal with the upper part of your foot.

*NOTE: A machine power shut-off switch is located under the operator seat. If there is no weight on the operator seat, the machine WILL NOT propel in any direction.*

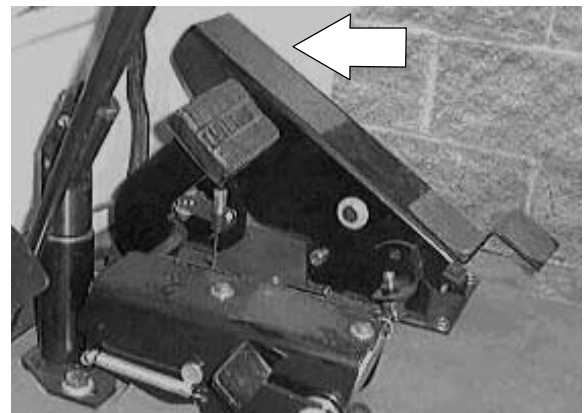

**Reverse:** Press the bottom of the directional pedal with the heel of your foot.

*When the directional pedal is placed into the reverse position, the rear squeegee will automatically raise. After a short delay, the vacuum will stop.*

**Neutral:** The machine will automatically return to the Neutral position when you take your foot off of the directional pedal.

*When the directional pedal returns to the neutral position the scrub head will stop. After a short delay, the scrub head will also raise.*

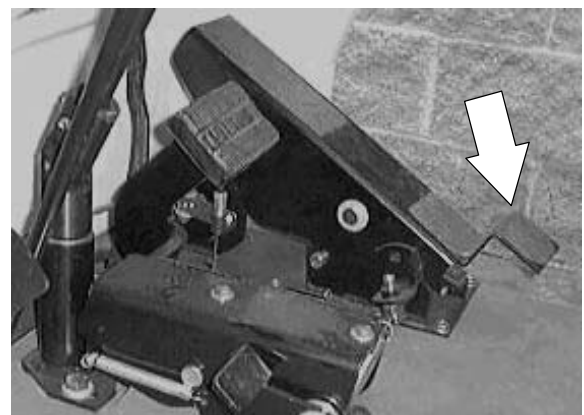

**TO REMOVE DIRECTIONAL PEDAL ASSEMBLY**

**FOR SAFETY: Before Leaving Or Servicing Machine; Stop On Level Surface, Set Parking Brake.**

1. Open the seat support and engage the prop rod.

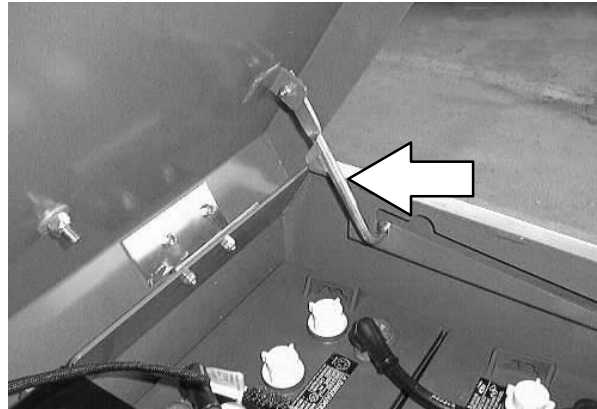

2. Disconnect the machine batteries.

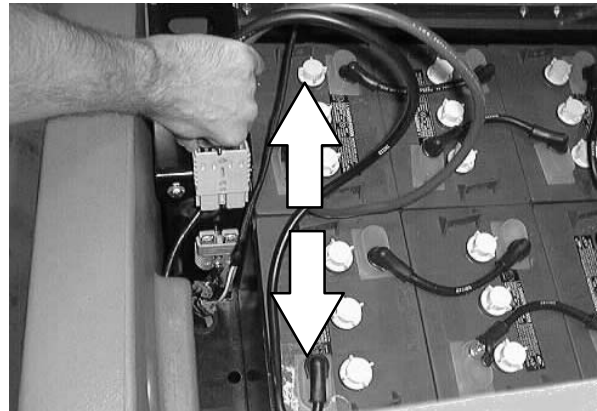

3. Go under the machine in the area of the right hand side brush. Locate the wires and connector leading from the directional pedal.

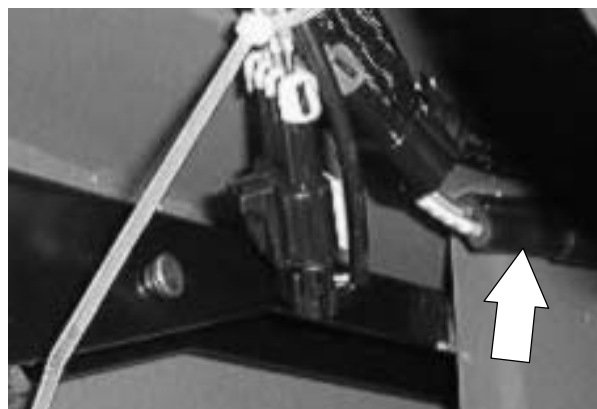

## ELECTRICAL

4. Disconnect the directional pedal connector from the main harness. Remove any plastic ties holding the directional pedal harness to the main harness.

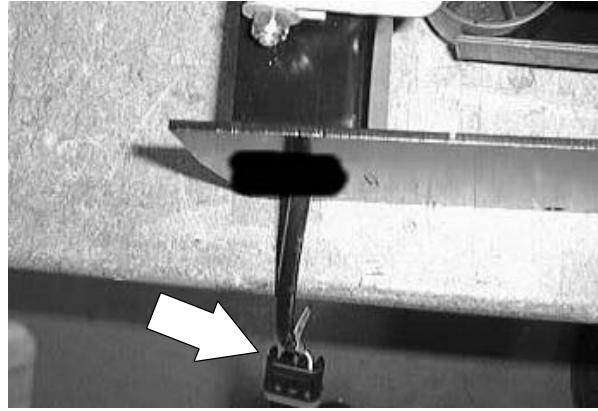

5. Go to the operators compartment and locate the directional pedal assembly. Remove the four thread rolling screws holding the directional pedal to the floor plate.

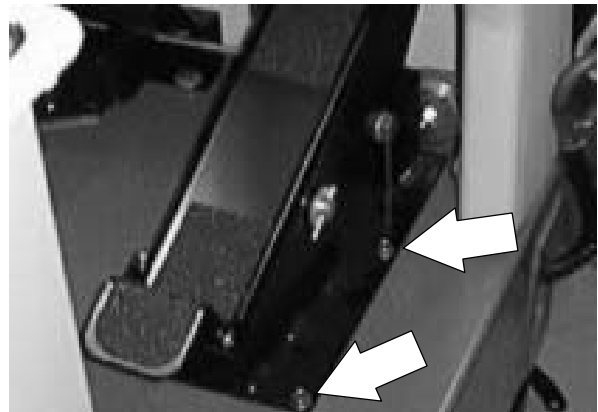

6. Remove the pedal assembly from the machine.

**TO INSTALL DIRECTIONAL PEDAL ASSEMBLY**

**FOR SAFETY: Before Leaving Or Servicing Machine; Stop On Level Surface, Set Parking Brake.**

1. Position the directional pedal assembly in the machines operators compartment.

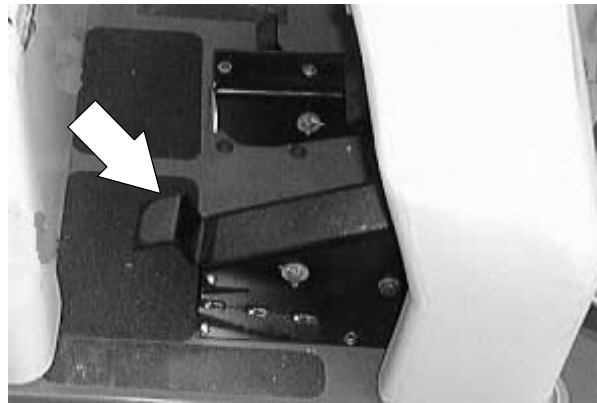

2. Feed the pedal harness down through the access hole in the floor plate.

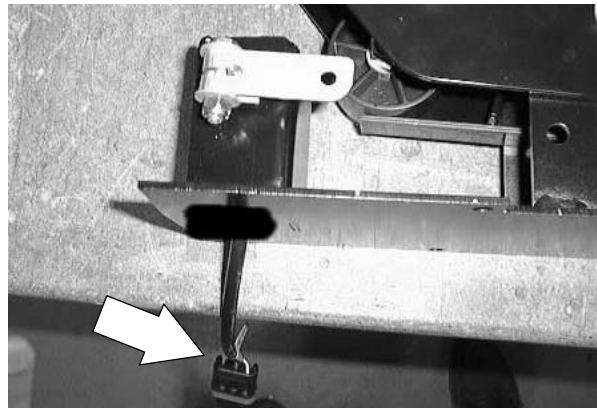

3. Line up the mount holes in the pedal assembly plate with the mount holes in the machines floor plate. Reinstall the four thread rolling screws and tighten to 8 – 10 Nm (6 – 7 ft lb).

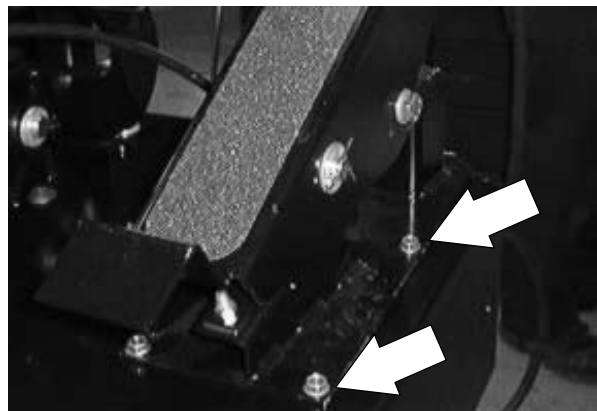

## ELECTRICAL

4. Go under the machine in the area of the right hand side brush. Locate the wires and connector leading from the directional pedal.
5. Reconnect the directional pedal connector to the main harness. Reinstall any plastic ties that were holding the directional pedal harness to the main harness.

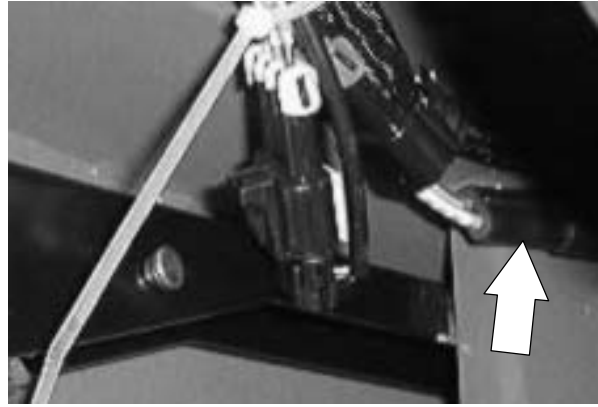

6. Reconnect the batteries.

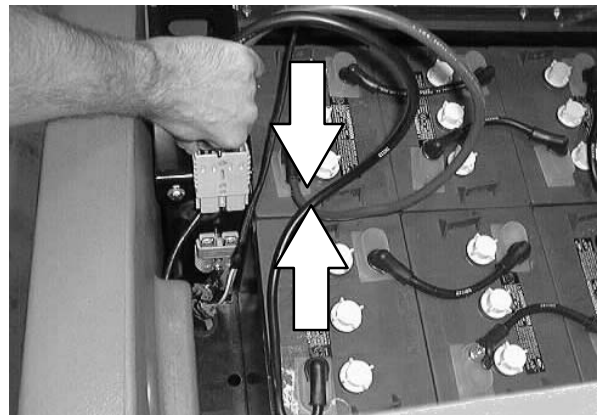

7. Disengage the prop rod and lower the seat support.



8. Start the machine and check for proper operation. Set the pedal neutral if needed. See TO SET POTENTIOMETER NEUTRAL instructions in this section.

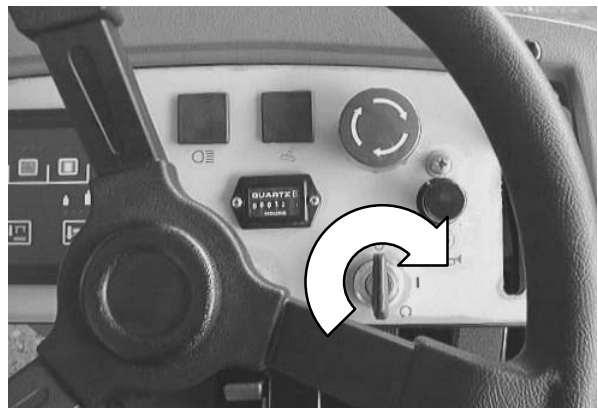



**TO REPLACE DIRECTIONAL PEDAL POTENTIOMETER**

**FOR SAFETY: Before Leaving Or Servicing Machine; Stop On Level Surface, Set Parking Brake.**

1. Remove the directional pedal assembly from the machine. See TO REMOVE DIRECTIONAL PEDAL ASSEMBLY instructions in this section.

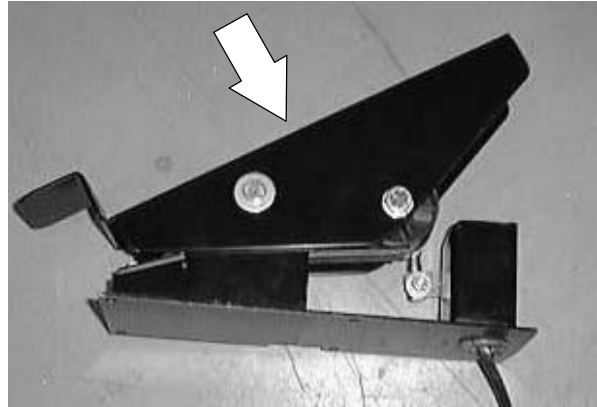

2. Loosen the hex screw and nut holding the accelerator lever to the potentiometer. Remove the accelerator lever from the potentiometer shaft.

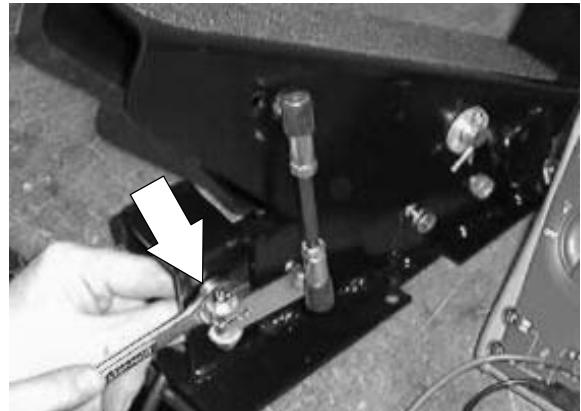

3. Remove the thin hex nut from the potentiometer shaft.

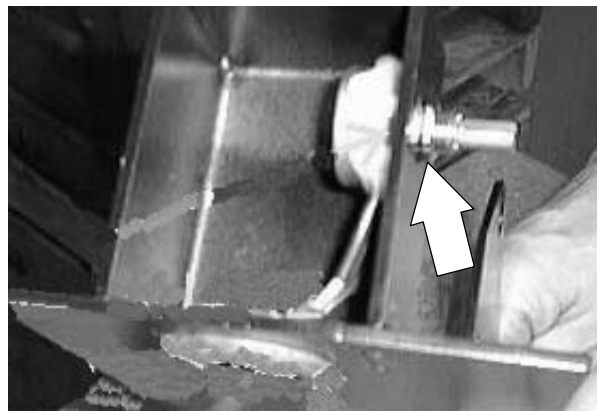

## ELECTRICAL

- Note the orientation of the existing potentiometer and remove it from the pedal assembly.
- Install the new potentiometer onto the pedal assembly in the same orientation as the old one. Reinstall the thin hex nut and **tighten lightly**.

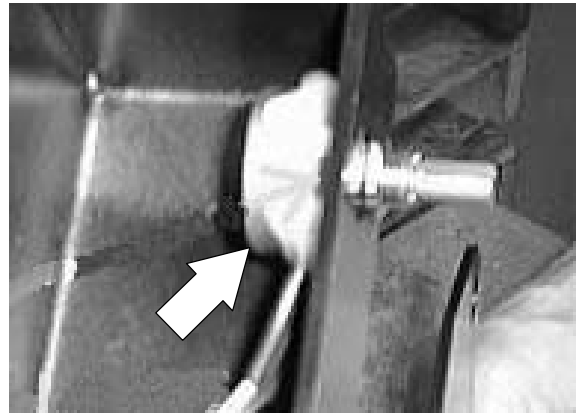

- With the directional pedal in the neutral position, reinstall the accelerator lever onto the shaft of the potentiometer. Hand tighten the hex screw and nut.

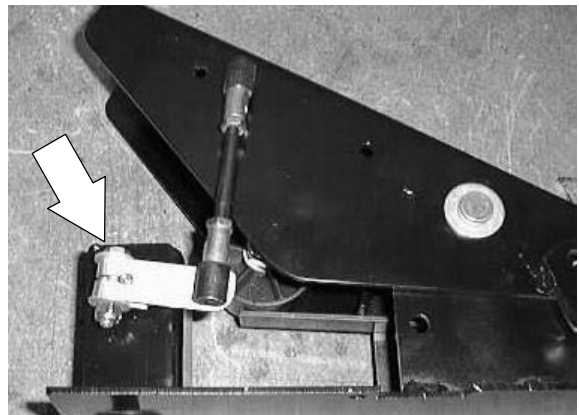

- Check the length of the threaded rod/ball joint assembly. Measure the distance between the ball joint centers. The dimension should be approximately 4 inches. If an adjustment needs to be made, loosen the upper jam nut and turn the rod. Re-tighten the jam nut.

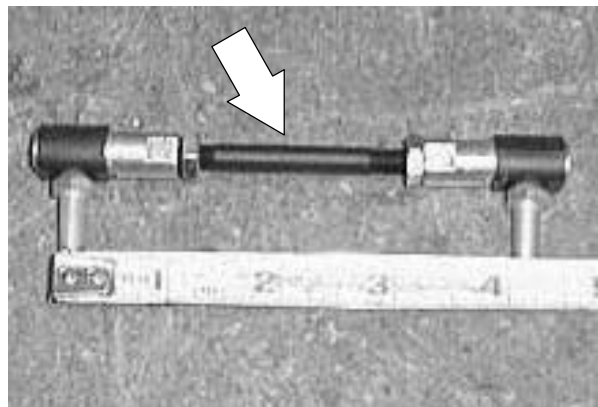

- Reinstall the directional pedal assembly into the machine. See TO INSTALL DIRECTIONAL PEDAL ASSEMBLY instructions in this section.



9. Check the new potentiometer for neutral.  
See TO SET POTENTIOMETER NEUTRAL instructions in this section.

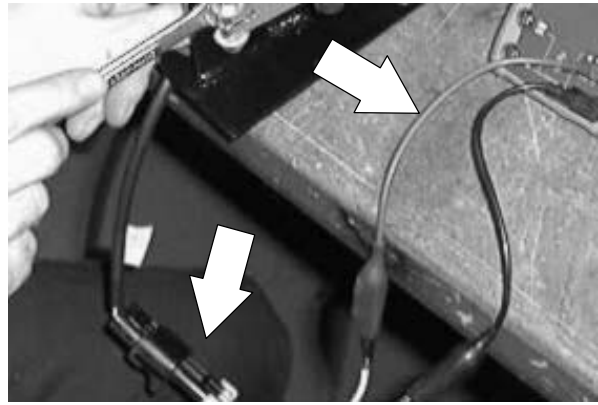

10. Operate the machine. Check the new potentiometer for proper operation.



## ELECTRICAL

### TO SET POTENTIOMETER NEUTRAL

**FOR SAFETY: Before Leaving Or Servicing Machine; Stop On Level Surface, Set Parking Brake.**

1. Open the seat support and engage the prop rod.

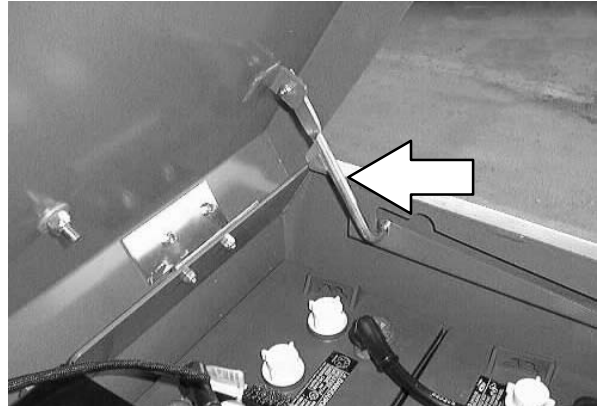

2. Disconnect the machine batteries.

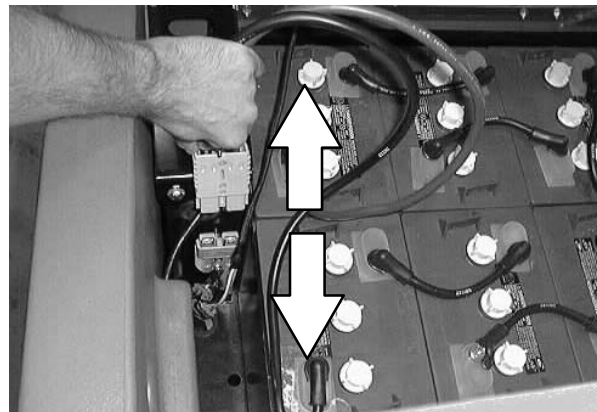

3. Go under the machine in the area of the right hand side brush. Locate the wires and connector leading from the directional pedal.

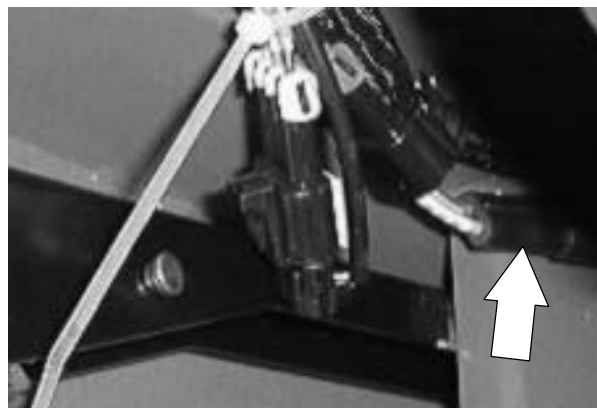

4. Disconnect the directional pedal connector from the main harness. Remove any plastic ties holding the directional pedal harness to the main harness.



5. Use a multimeter, set to the OHMS setting. Check the red (B) and white (A) of the connector with the meter.
6. The meter reading should be 2500 OHMS ( $\pm$  50 OHMS).

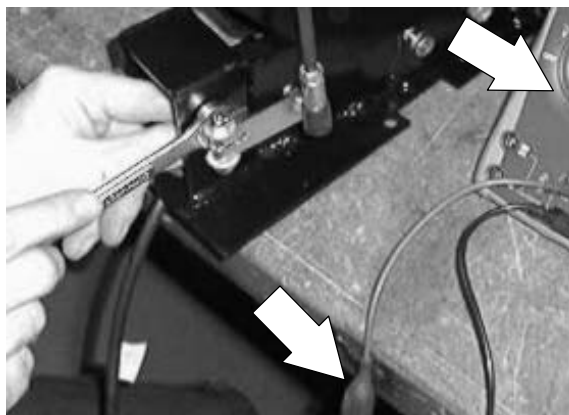

7. Loosen the upper jam nut on the threaded rod. Turn the rod to achieve the proper OHM reading. Tighten the jam nut.

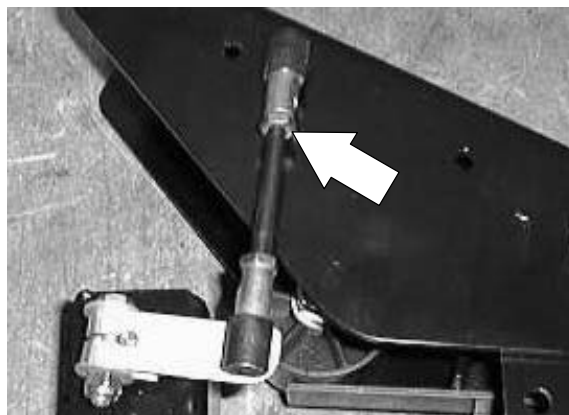

8. Reconnect the batteries.

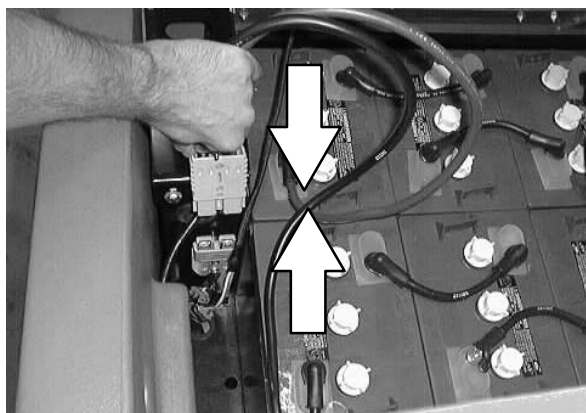

## ELECTRICAL

9. Disengage the prop rod and lower the seat support.



10. Operate the machine. Check the machine for proper neutral operation.



**TO REPLACE MOTOR CONTROLLER**

**FOR SAFETY: Before Leaving Or Servicing Machine; Stop On Level Surface, Set Parking Brake.**

1. Open the control panel. See TO ACCESS CONTROL PANEL instructions.

**FOR SAFETY: Disconnect Battery Connections Before Working On machine.**

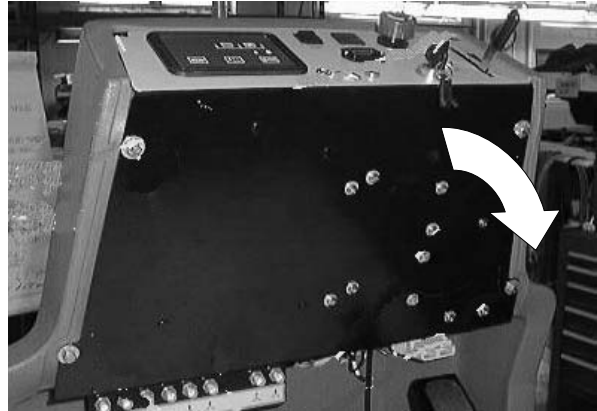

2. Locate the controller box in the center of the control panel.

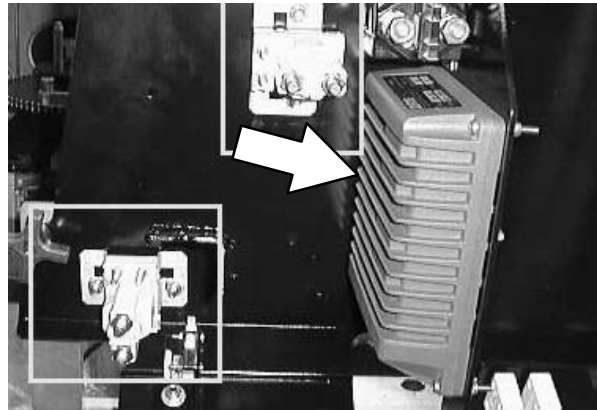

3. Disconnect the wires and power cables leading to the controller.

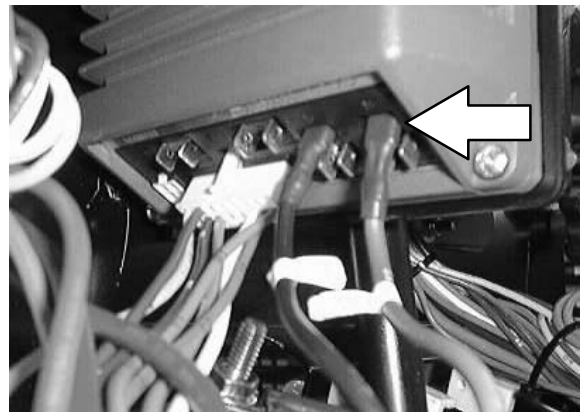

## ELECTRICAL

4. Remove the three screws and nuts holding the controller to the panel. Remove the controller from the machine.

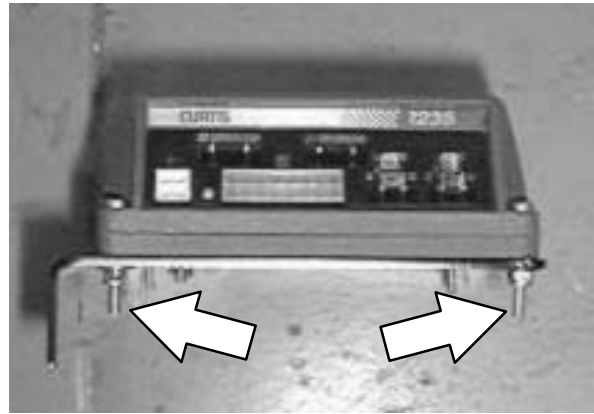

5. Position the new controller on the panel. Reinstall the screws and nuts. Hand tighten.

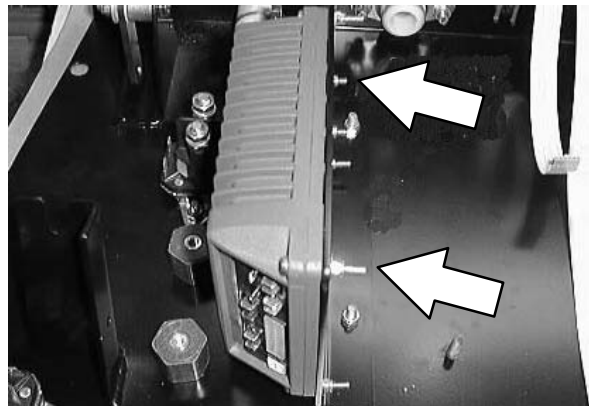

6. Reconnect the power cables and electrical wires to the controller. See the schematic in this section.

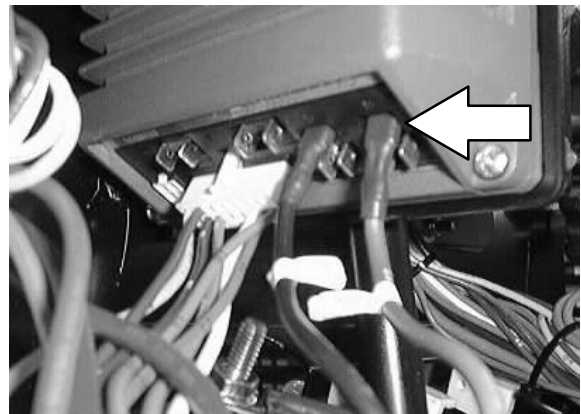



- Pivot the control panel back in position. Reinstall the two screws and tighten to 18 – 24 Nm (15 – 20 ft lb).

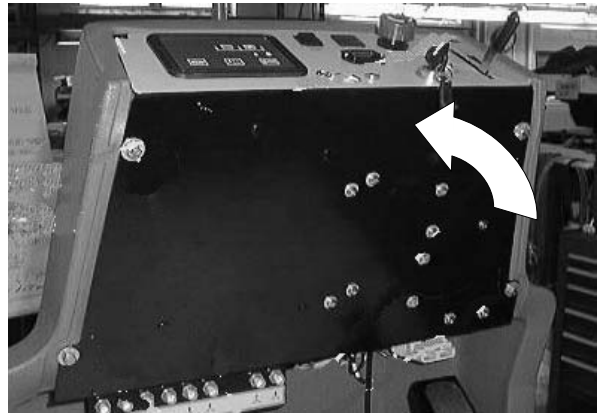

- Lift the operator seat and reconnect the battery connector at the front of the solution tank.

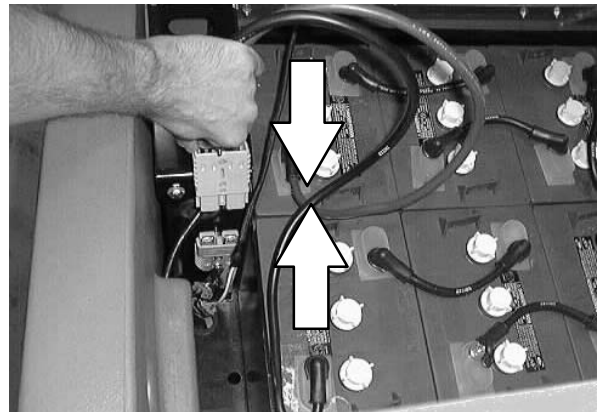

- Start the machine and check for proper operation of the propelling.



### ELECTRIC MOTORS

---

The carbon brushes on the vacuum fan motor should be inspected after every 500 hours of machine operation. The carbon brushes on the scrub brush motors and propelling motor should be inspected after every 1000 hours of machine operation.

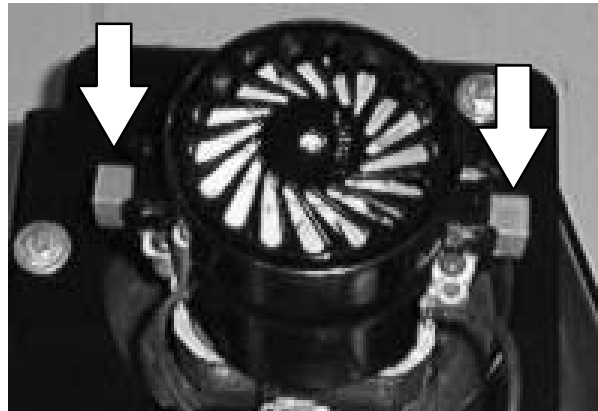

### TO REPLACE DRIVE MOTOR ASSEMBLY

**FOR SAFETY: Before Leaving Or Servicing Machine; Stop On Level Surface, Set Parking Brake.**

The front drive motor is part of the front drive assembly. See TO REMOVE FRONT DRIVE ASSEMBLY instructions in the CHASSIS section if the front drive motor needs repair.



**TO REPLACE DISC SCRUB HEAD BRUSH MOTOR**

**FOR SAFETY: Before Leaving Or Servicing Machine; Stop On Level Surface, Set Parking Brake.**

1. Remove the side squeegees. See TO REPLACE SIDE SQUEEGEE BLADES instructions in the SCRUBBING section.

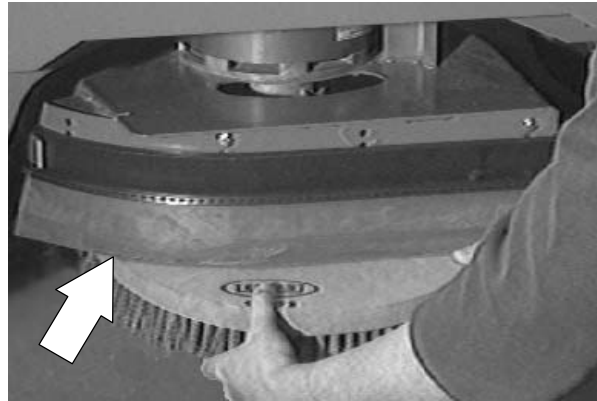

2. Remove the scrub brushes. See TO REPLACE DISC SCRUB BRUSHES instructions in the SCRUBBING section.

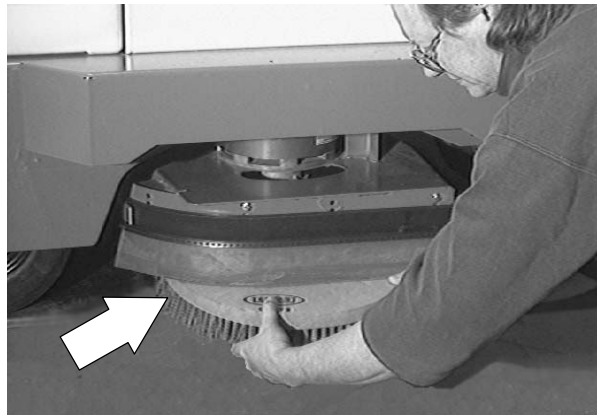

3. Go in under the scrub head and remove the screw and washer from the center of the brush drive plug.

4. Drop the drive plug down off the motor shaft. Make sure to retain the square key.

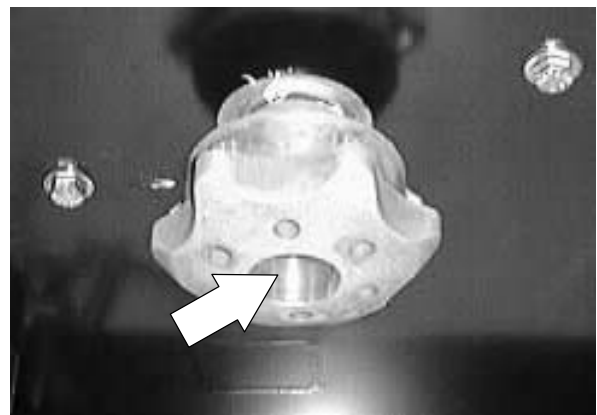

## ELECTRICAL

5. Remove the four screws holding the brush motor to the scrub head.

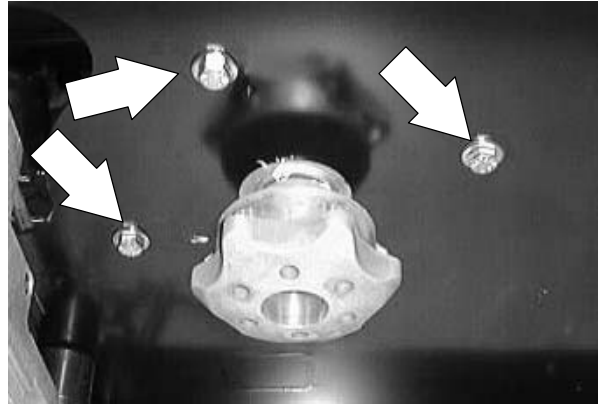

6. Start the machine and lower the scrub head. Shut off the key.



7. Go in on top of the scrub head and disconnect the scrub brush motor from the main harness. Note the orientation of wire to motor.

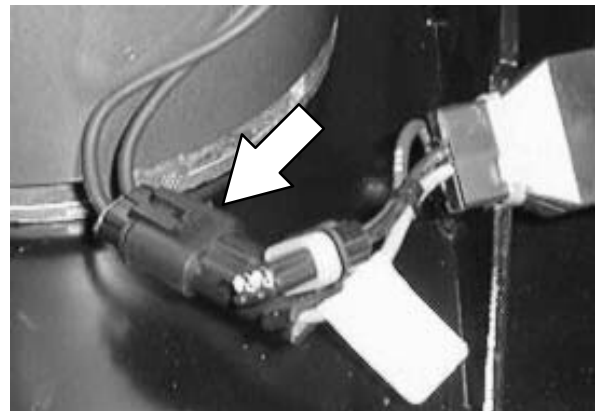

8. Lift the brush motor off the deck of the scrub head and remove it from the machine. Note the orientation of the brush motor power cable. The new motor must be orientated the same direction.

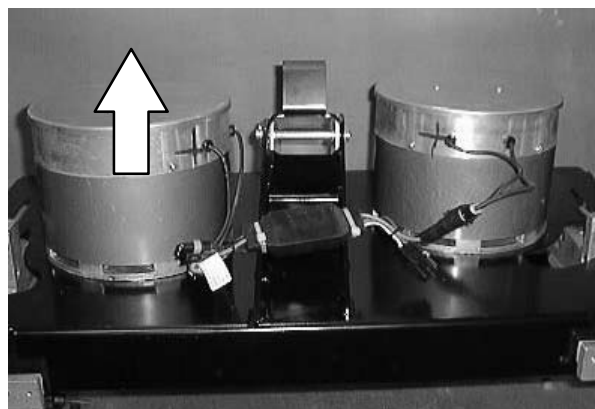

9. Position the new motor on the scrub head.

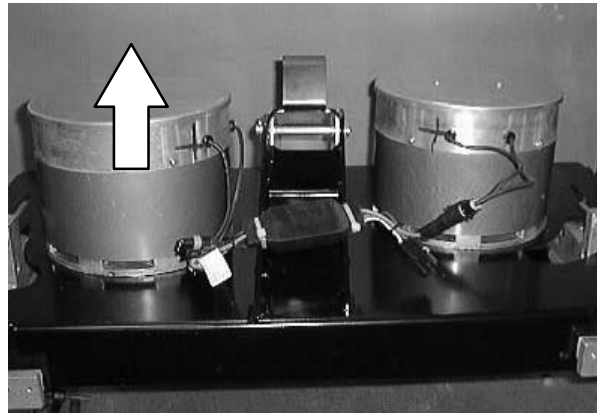

10. Reconnect the motor wires to the main electrical harness. See schematic in this section.

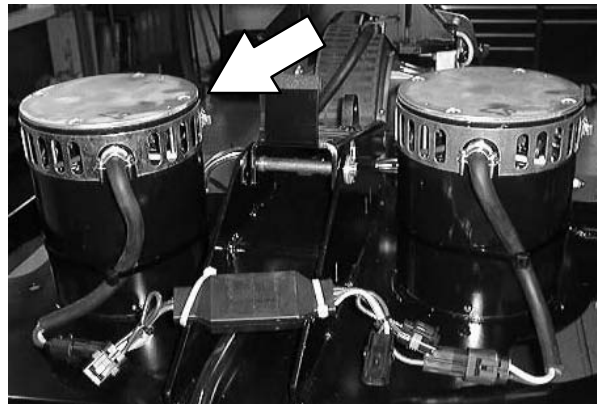

11. Start the machine and raise the scrub head. Shut off the key.



12. Rotate the brush motor until it is orientated properly and the mount holes line up with the holes in the deck of the scrub head. Install the four screws and tighten to 11 – 14 Nm (7 – 10 ft lb).

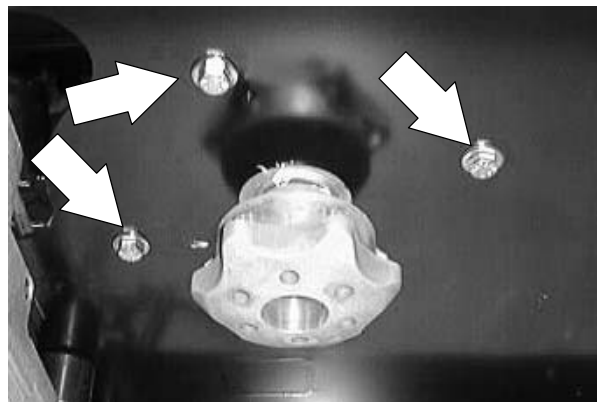

## ELECTRICAL

13. Install the square key and drive plug on the brush motor shaft. Install the screw and washer in the center of the drive plug. Tighten to 18 – 24 Nm (15 – 20 ft lb).

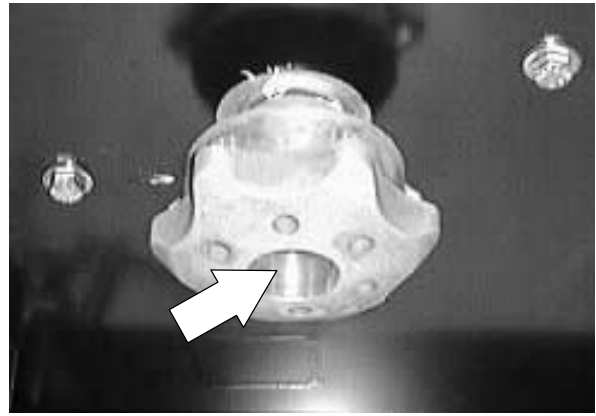

14. Reinstall the scrub brush. See TO REPLACE DISC SCRUB BRUSHES instructions in the SCRUBBING section.

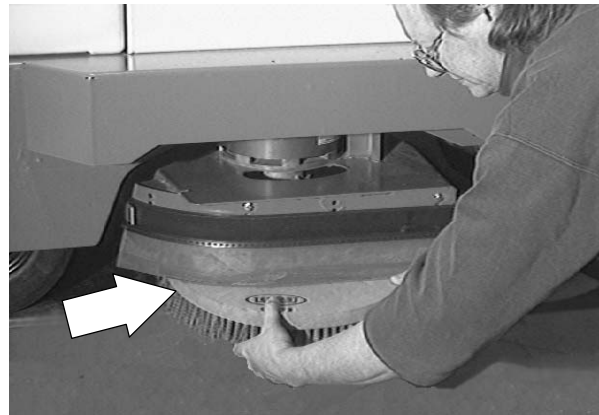

15. Reinstall the side squeegees. See TO REPLACE SIDE SQUEEGEE BLADES instructions in the SCRUBBING section.

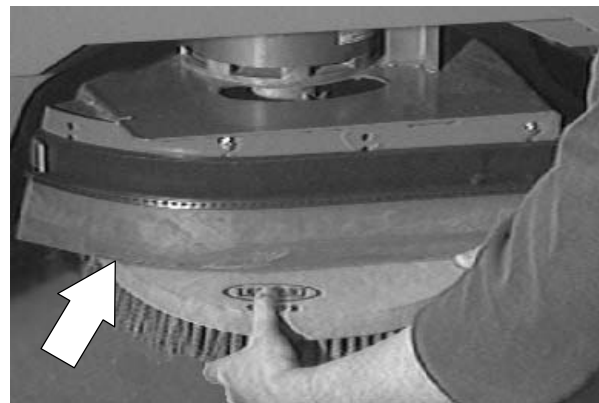

16. Start the machine and operate the scrubbing function. Check for proper operation and rotation of the new motor.

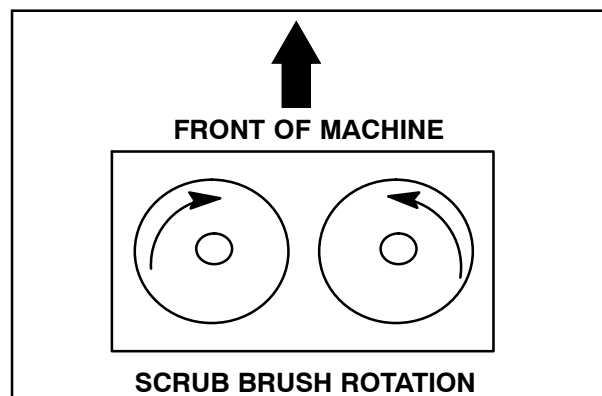

**TO REPLACE CYLINDRICAL SCRUB HEAD BRUSH MOTOR**

**FOR SAFETY: Before Leaving Or Servicing Machine; Stop On Level Surface, Set Parking Brake.**

1. Remove the side squeegees. See TO REPLACE SIDE SQUEEGEE BLADES instructions in the SCRUBBING section.

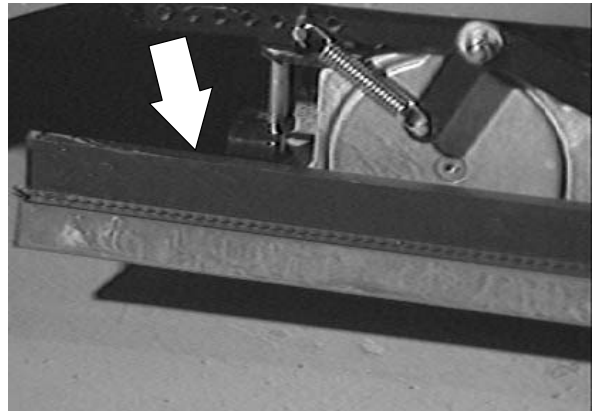

2. Remove the scrub brushes. See TO REPLACE DISC SCRUB BRUSHES instructions in the SCRUBBING section.

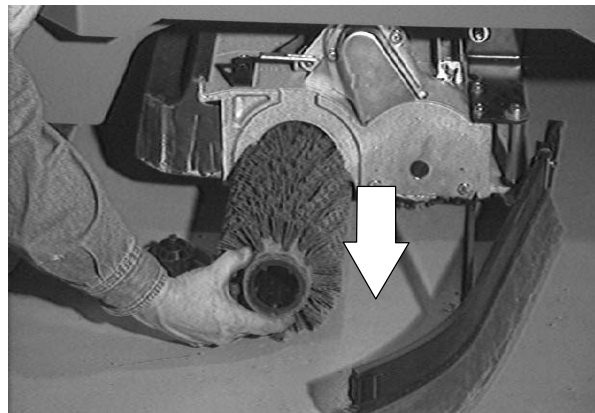

3. Start the machine and lower the scrub head. Shut off the key.



## ELECTRICAL

4. Go in on top of the scrub head and disconnect the scrub brush motor from the main harness. *Note the orientation of wire to motor.*

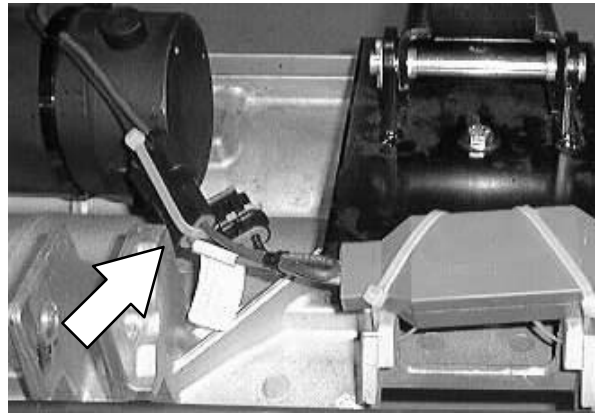

5. Loosen the pivot mount bolts on the brush motor.

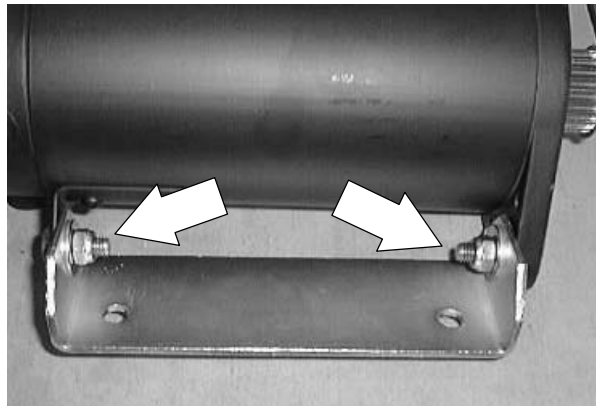

6. Remove the two screws holding the brush motor belt cover to the brush motor. Remove the belt cover from the scrub head.

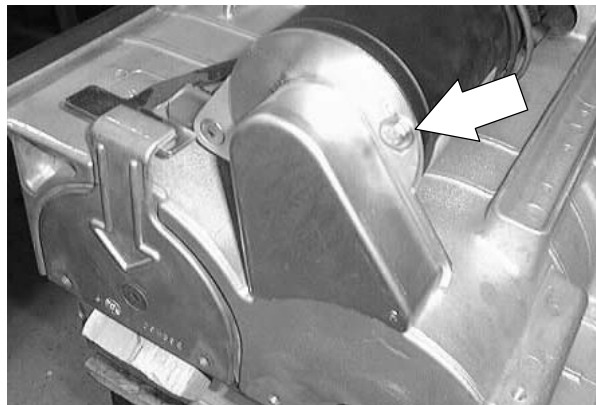

7. Loosen the jam nut on the belt tension bolt under the brush motor. *Turn the tension bolt down far enough to slip the the belt off the cogged pulley.*

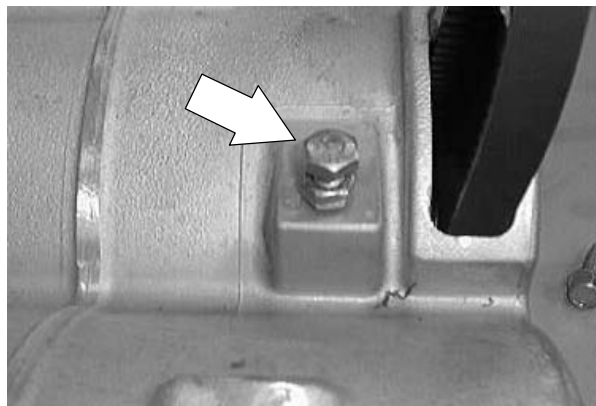



- Remove the two screws holding the brush motor to the pivot bracket. Remove the brush motor from the machine.

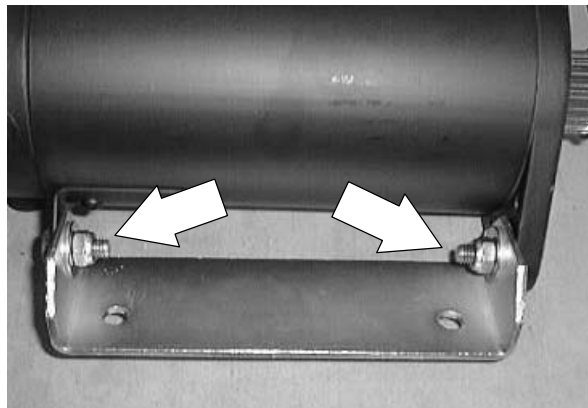

- Loosen the set screws holding the cogged pulley to the brush motor shaft. Slide the pulley off the shaft. *Do not lose the square key.*

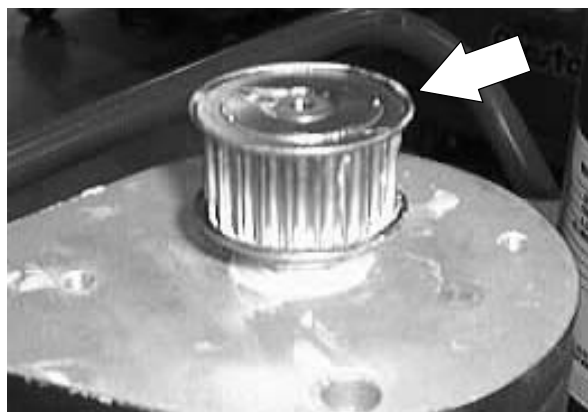

- Install the cogged pulley and square key onto the shaft of the new brush motor. *Leave the set screws loose for now.*

- Position the new brush motor on the scrub head. Align the mounting holes on the motor with the holes in the pivot mount bracket. Install the two screws. Snug the hardware for now.



- Slip the brush belt over the cogged pulley.

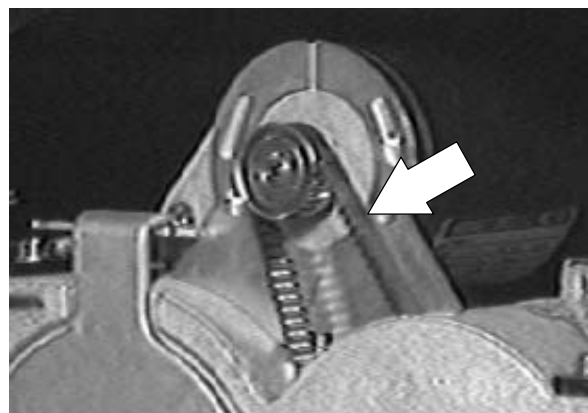

## ELECTRICAL

- Align the top pulley with the bottom drive plug. Make sure the belt is in the center of the top pulley. Tighten the set screws tight. *Use loctite 242 blue on the threads.*

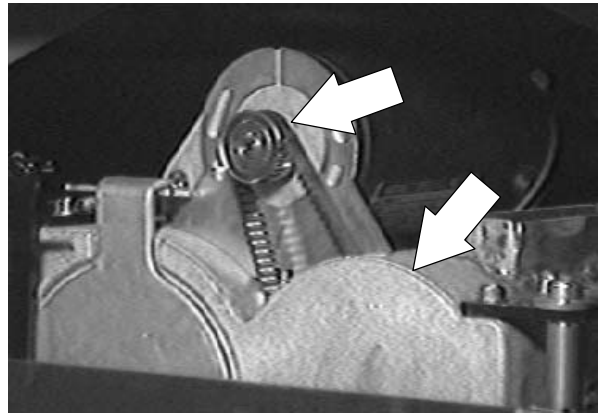

- Use the hex screw under the brush motor to tension the belt. Apply 2.5–2.7 lbs. of force at the middle of the span that is opposite belt travel. There should be 0.10 inch of deflection.

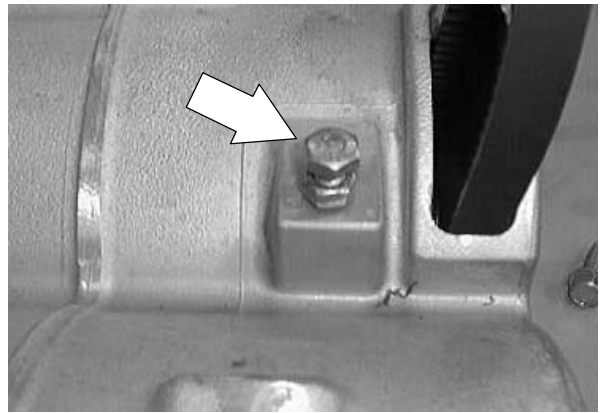

- Tighten the two motor pivot screws to 18 – 24 Nm (15 – 20 ft lb). Re-check the belt tension.

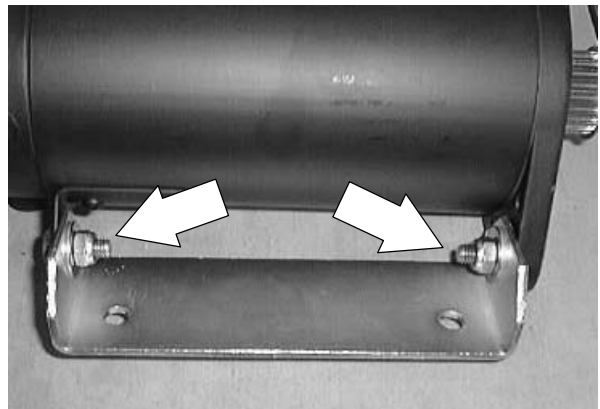

- Reconnect the brush motor into the main harness. See schematic in this section.

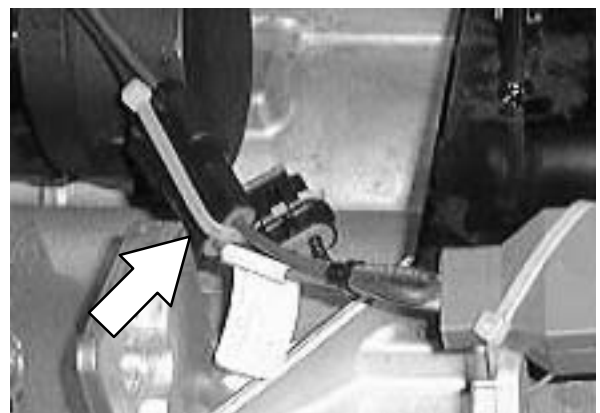

17. Reinstall the belt cover. Tighten the screws to 11 – 14 Nm (7 – 10 ft lb). Apply a small amount of RTV sealant on the flange of the belt cover to keep dust out of the cogs of the belt.

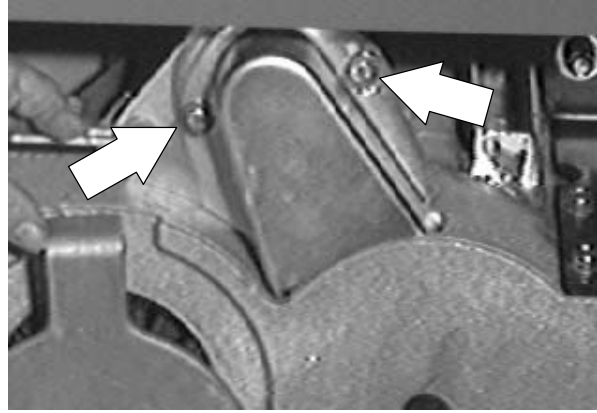

18. Reinstall the scrub brushes. See TO REPLACE CYLINDRICAL SCRUB BRUSHES instructions in the SCRUBBING section.

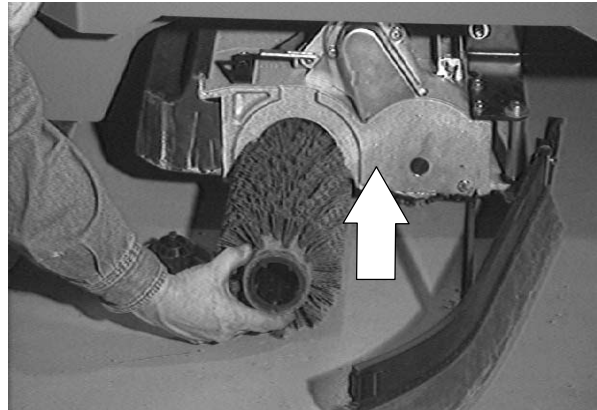

19. Operate the machine and check the scrub brush motor for proper operation.

## LIFT ACTUATORS

The lift actuators are electric devices that, with a push of a switch, raise and lower either the scrub head or the rear squeegee.

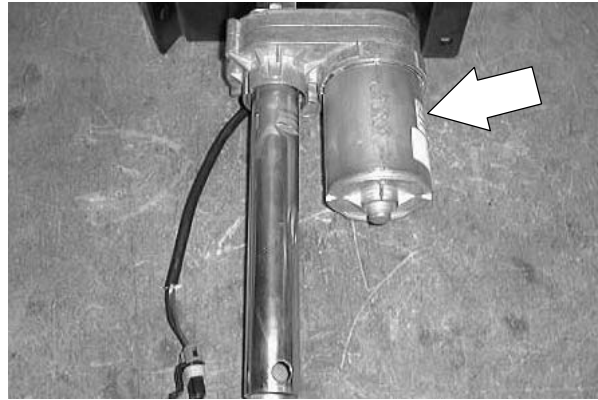

### TO REPLACE SCRUB HEAD LIFT ACTUATOR

1. Start the machine and lower the scrub head to the floor. Shut off the machine.

**FOR SAFETY: Before Leaving Or Servicing Machine; Stop On Level Surface, Set Parking Brake.**



2. Go in on top of the scrub head and remove the cotter pin and clevis pin from the bottom of the scrub head lift actuator tube.

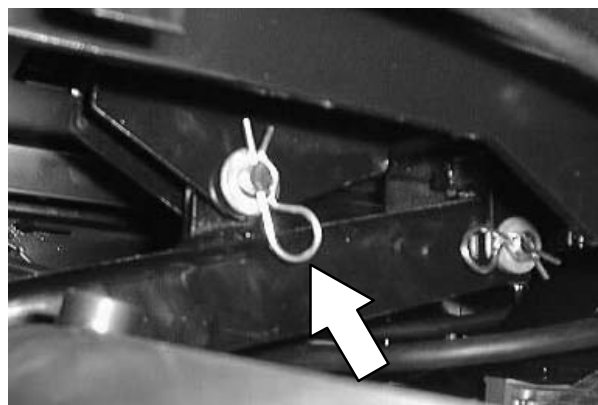

3. Raise the seat support and unplug the battery connector.

**FOR SAFETY: Disconnect Battery Connections Before Working On machine.**

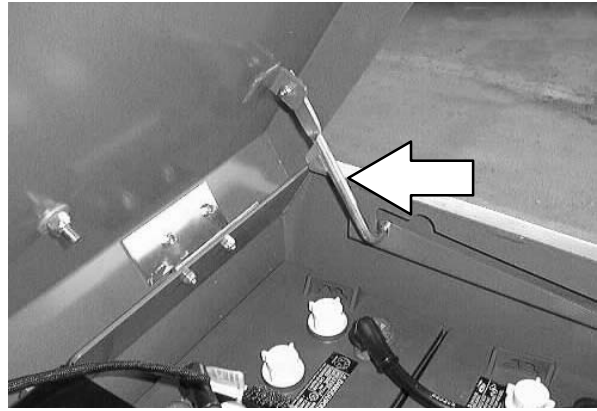

4. Locate the four screws holding the lift actuator mount bracket to the front of the seat support and the back of the actuator mount tower. Remove the four screws.

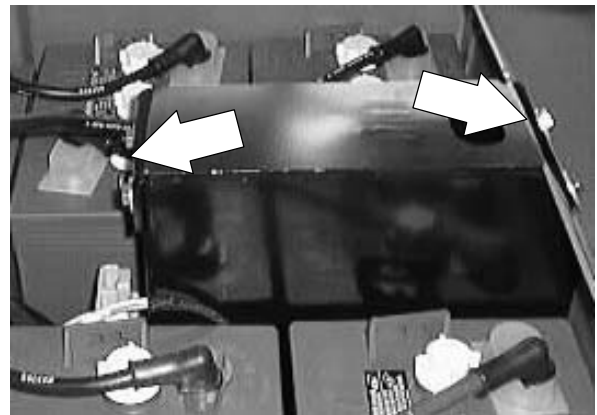

5. Lift the actuator and spring mount bracket up far enough to disconnect the actuator from the main harness.

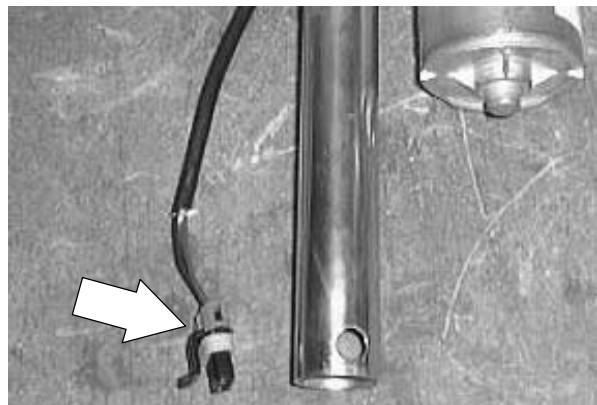

6. Lift the actuator and spring mount bracket out of the assembly and remove from the machine.

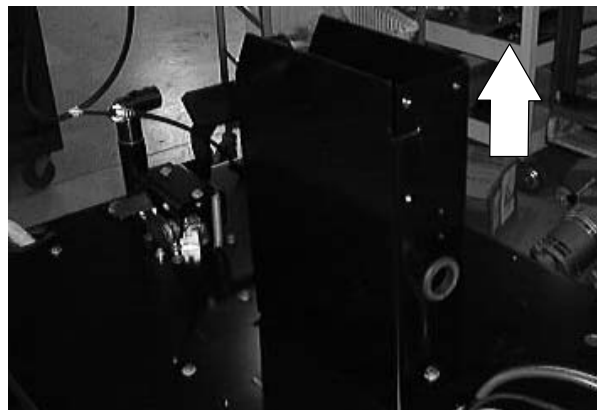

## ELECTRICAL

7. Remove the cotter pin and clevis pin holding the actuator to the spring mount bracket. Remove the spring bracket.

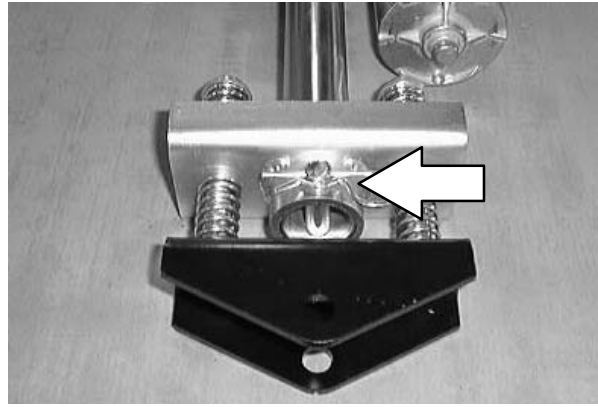

8. Position the spring mount bracket onto the new actuator. Install the clevis and cotter pins.

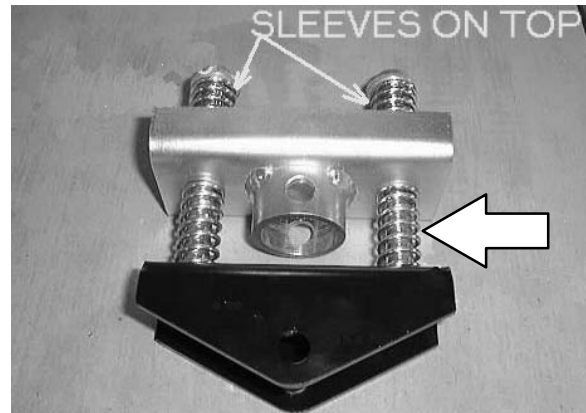

9. Remove the cotter pin and clevis pin holding the top mount bracket to the existing lift actuator. Install the mount plate onto the new actuator.

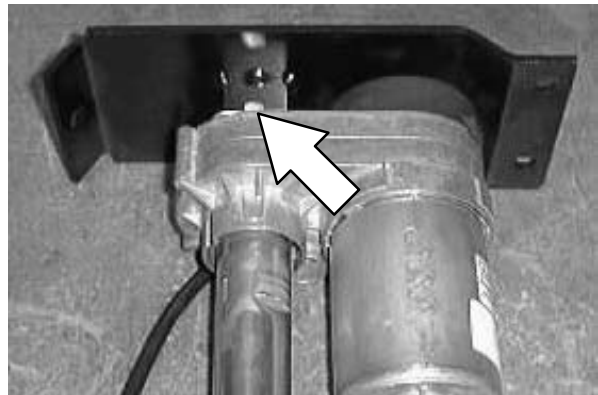

10. Position the new actuator and spring mount bracket in the machine. Slide the assembly down into the mount tower. Route the actuator wire and plug the connector into the main harness.

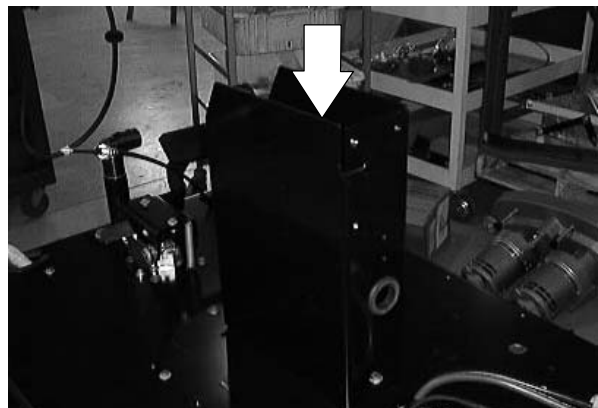

11. Reinstall the four screws in the actuator mount bracket. Tighten the four screws to 18 – 24 Nm (15 – 20 ft lb).

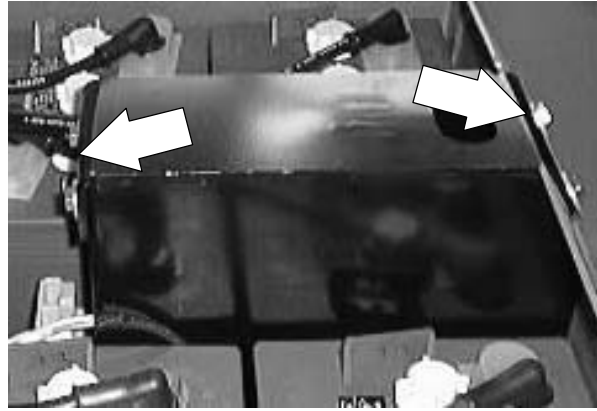

12. Go in on top of the scrub head and install the clevis and cotter pin in the bottom of the scrub head lift actuator tube and scrub head lift bracket.

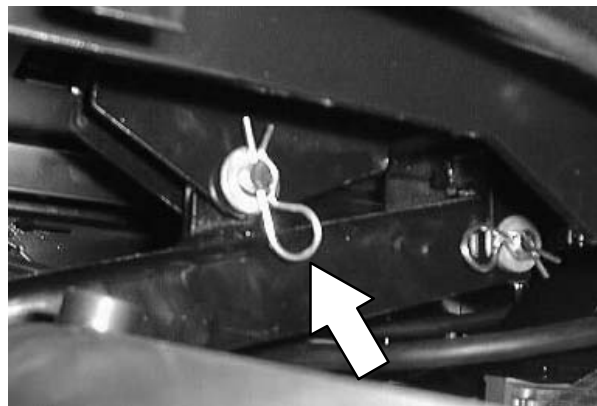

13. Plug in the battery connector. Lower the seat assembly.

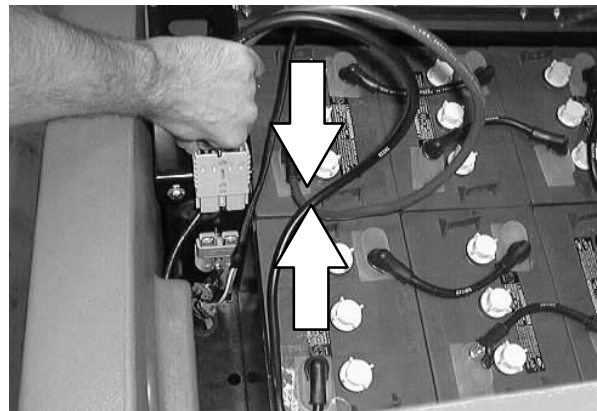

14. Operate the machine and check the scrub head lift actuator for proper operation.

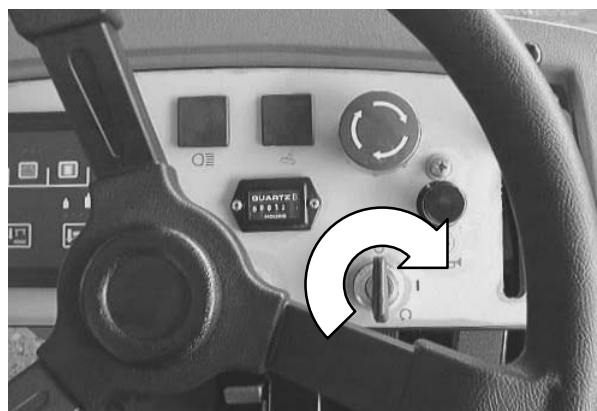

## ELECTRICAL

### TO REPLACE REAR SQUEEGEE LIFT ACTUATOR

1. Make sure the solution and recovery tanks have been drained.
2. Start the machine and lower the rear squeegee. Shut off the machine.

**FOR SAFETY: Before Leaving Or Servicing Machine; Stop On Level Surface, Set Parking Brake.**

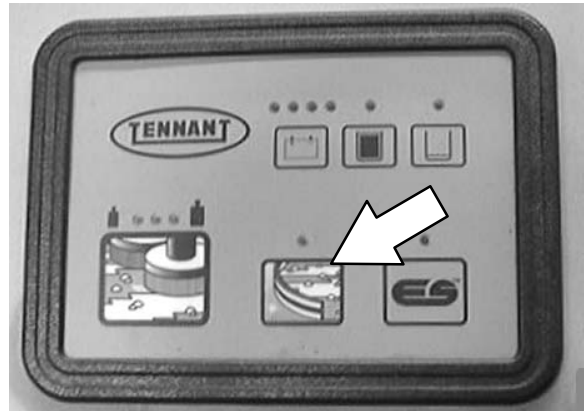

3. Remove the hardware holding the drip tray to the back of the tanks. Remove the drip tray from the machine.

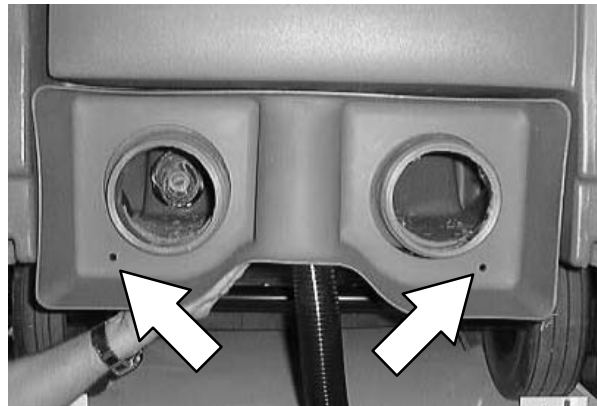

4. Remove the rear squeegee assembly. See TO REMOVE REAR SQUEEGEE ASSEMBLY instructions in the SCRUBBING section.

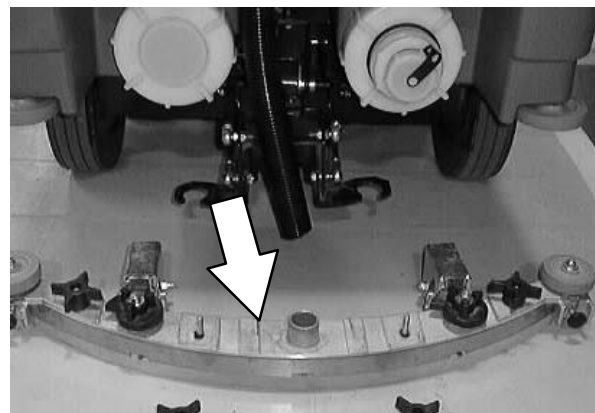



5. Disconnect the rear squeegee lift actuator from the main harness.

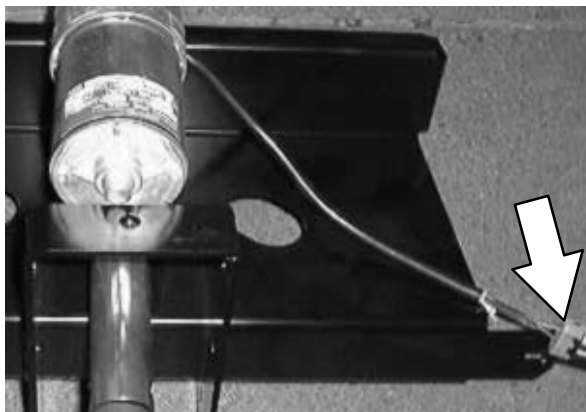

6. Remove the three screws holding the squeegee mount channel to the back of the machine.

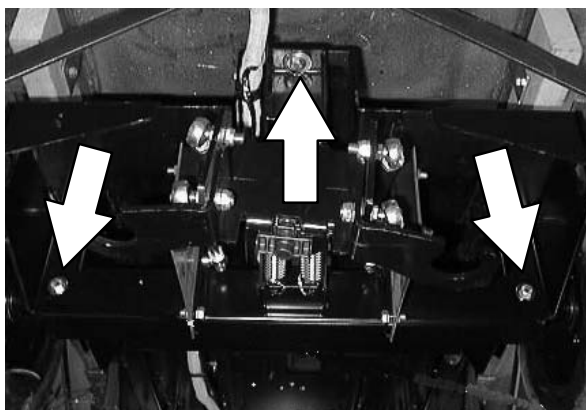

7. Remove the two remaining screws (located in front of the rear tires).

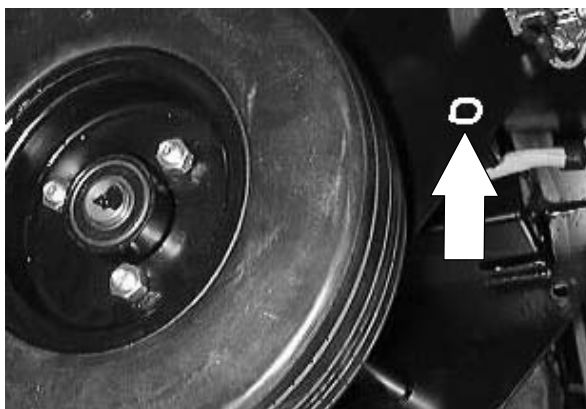

8. Let the squeegee mount channel and squeegee assembly drop down to access the lift actuator.

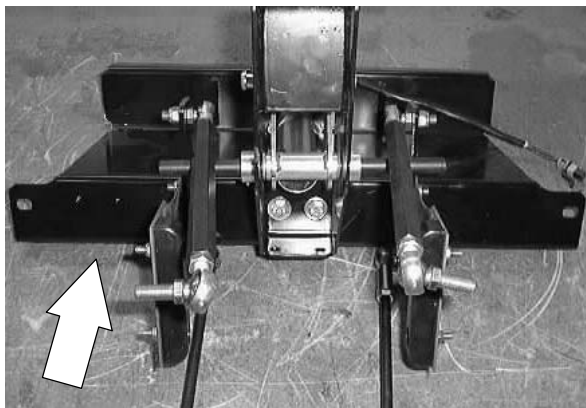

## ELECTRICAL

9. Remove the cotter pin and clevis pin from the tube end of the lift actuator.

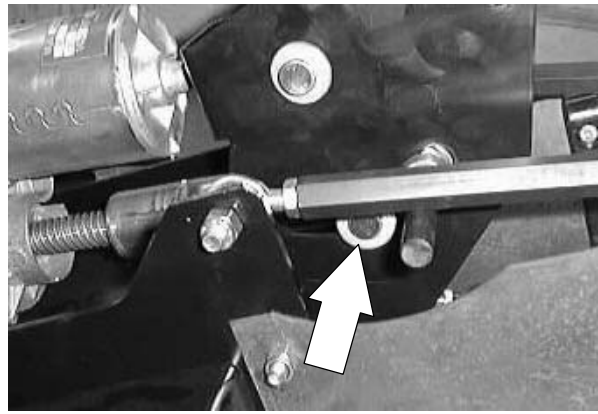

10. Remove the cotter pin and clevis pin from the motor end of the lift actuator. Remove the actuator from the squeegee frame.



11. Install the new actuator into the squeegee frame in the same orientation as the old one was removed. Reinstall the two clevis pins and cotter pins.

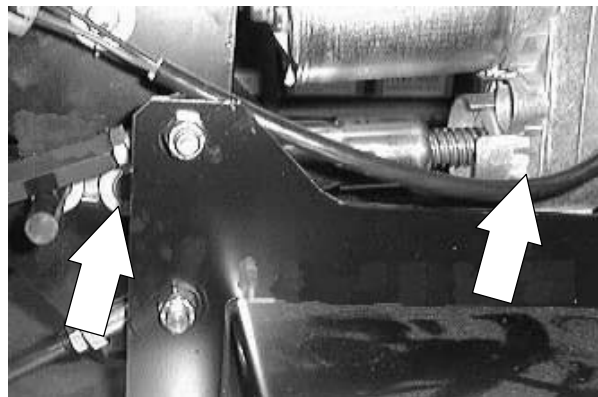

12. Position the squeegee frame assembly back onto the rear of the machine frame.

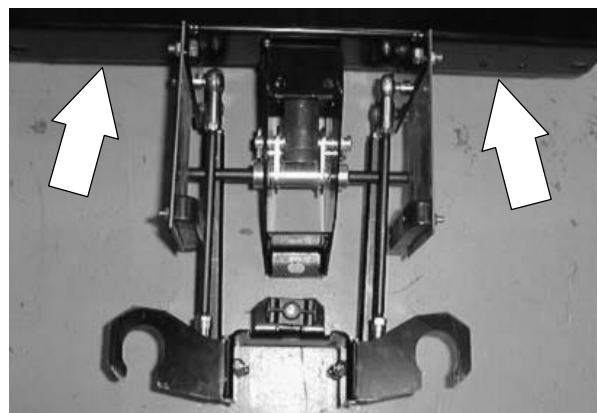

13. Reinstall the three screws holding the squeegee mount channel to the back of the machine. Tighten to 18 – 24 Nm (15 – 20 ft lb).

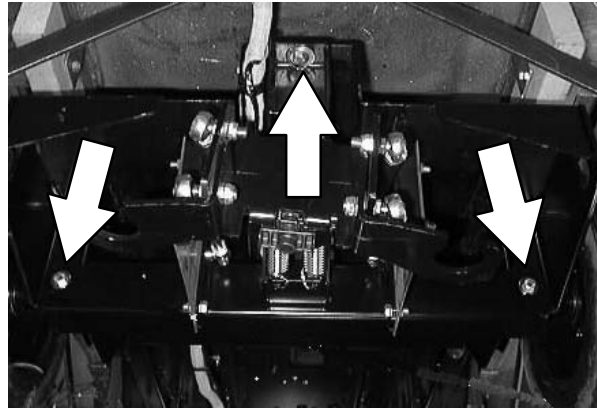

14. Reinstall the two remaining screws (located in front of the rear tires). Tighten to 18 – 24 Nm (15 – 20 ft lb).

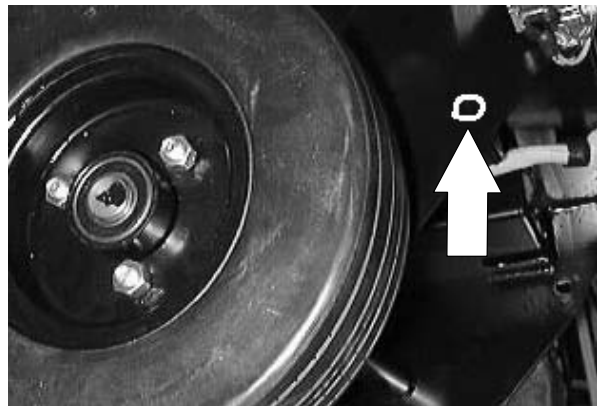

15. Reconnect the squeegee lift actuator to the main electrical harness. See schematic in this section.

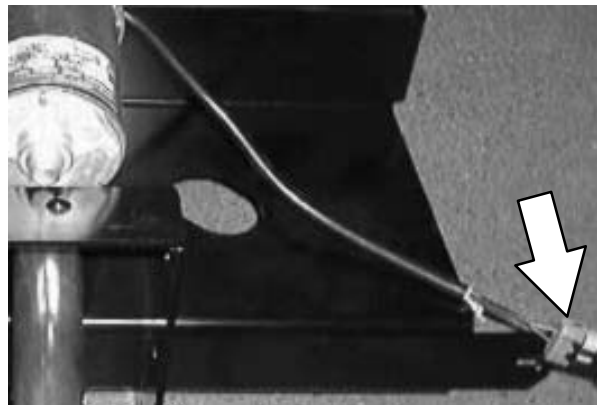

16. Reinstall the drip tray. Tighten the two hex screws to 18 – 24 Nm (15 – 20 ft lb).

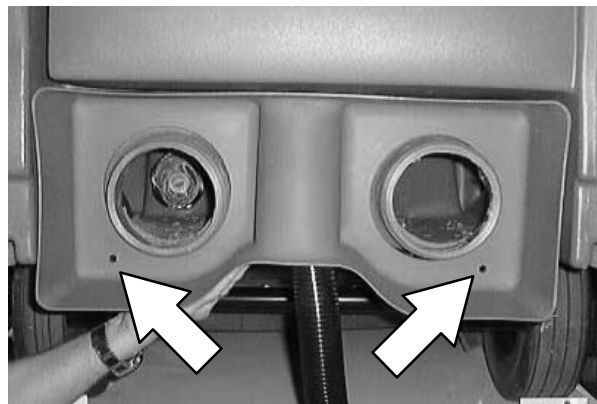

## ELECTRICAL

17. Reinstall the squeegee assembly. See TO INSTALL REAR SQUEEGEE ASSEMBLY instructions in the SCRUBBING section.

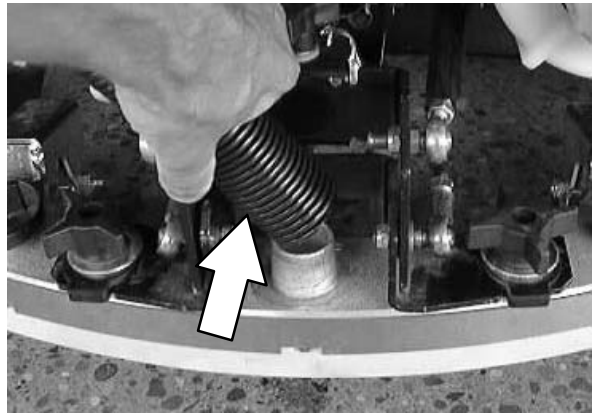

18. Start the machine and check the rear squeegee actuator for proper operation.



## ES™ PUMP

The ES™ pump is used to transfer filtered water from the recovery tank to the solution tank. With the ES™ system activated, float switches in the recovery tank and solution tank are used to turn the pump on and off automatically.

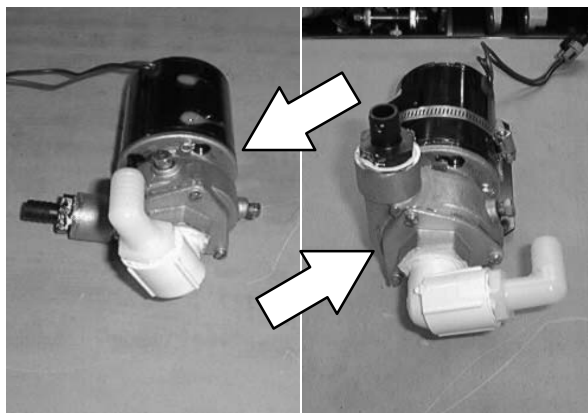

## TO REPLACE ES™ PUMP

**FOR SAFETY: Before Leaving Or Servicing Machine; Stop On Level Surface, Set Parking Brake.**

1. Make sure the solution and recovery tanks are empty.

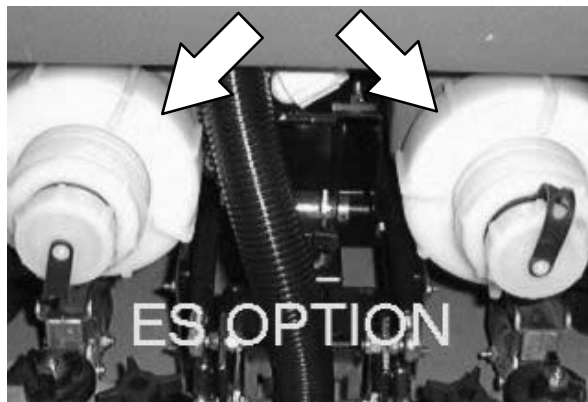

2. Remove the solution tank. See TO REMOVE SOLUTION TANK instructions in the scrubbing section.



## ELECTRICAL

3. Locate the ES™ pump next to the center, bottom edge of the recovery tank.

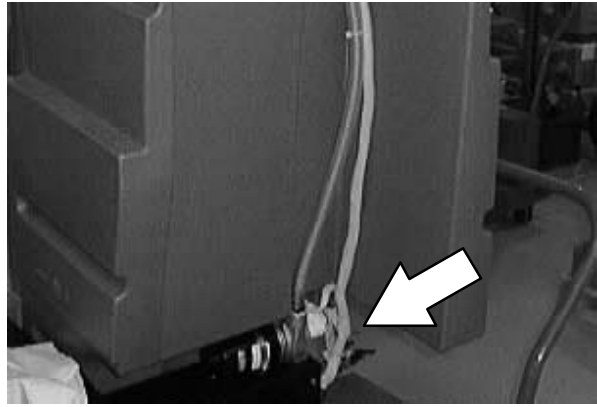

4. Disconnect the ES™ pump from the main electrical harness.

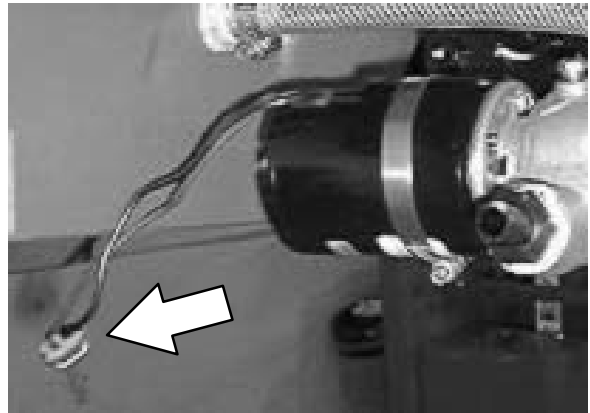

5. Loosen the worm drive clamps holding the solution hoses to the ES™ pump. Pull the hoses off the pump fittings.

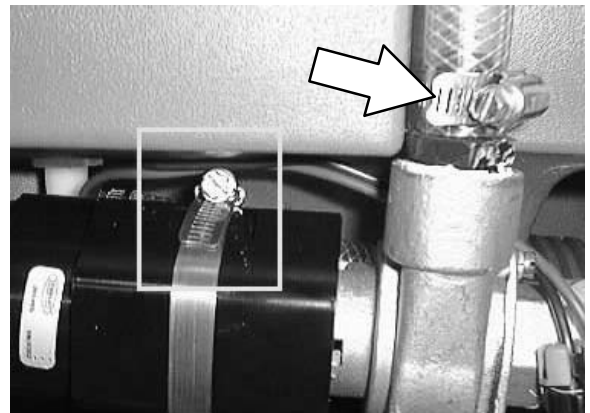

6. Loosen the worm drive clamp holding the ES™ pump to the mount bracket.

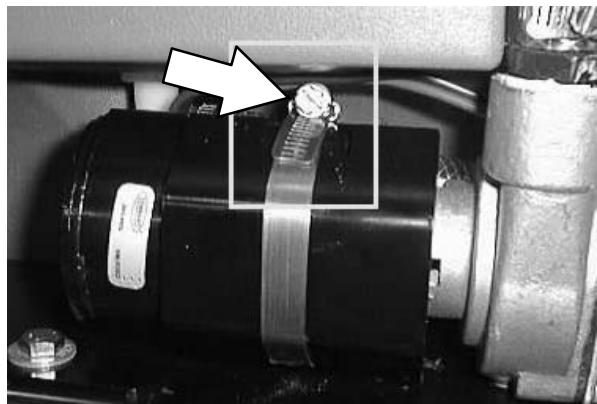

7. Pull the ES™ pump assembly out of the machine.

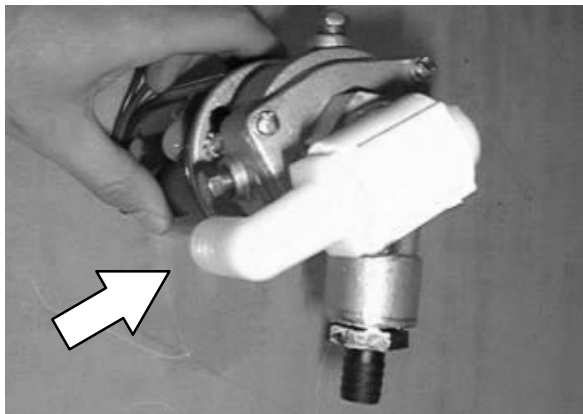

8. Remove the plastic fittings from the old pump and install in the new pump in the same orientation.

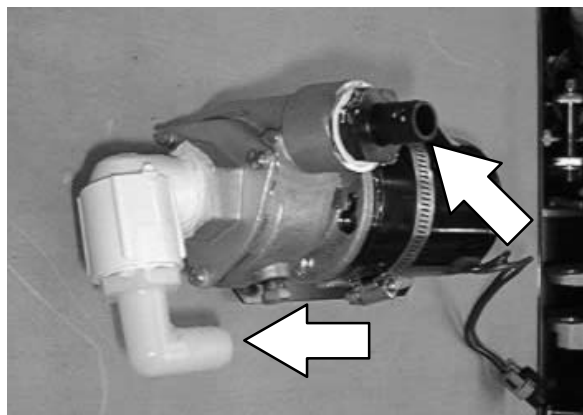

9. Install the new ES™ pump on the mount plate. Hand tighten the worm drive clamp.

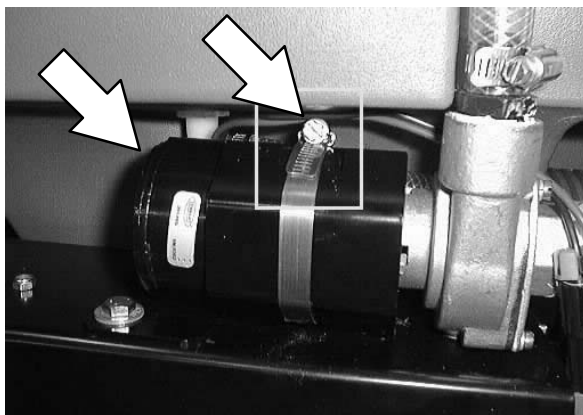

10. Reinstall the hoses onto the inlet and outlet ports on the new pump.

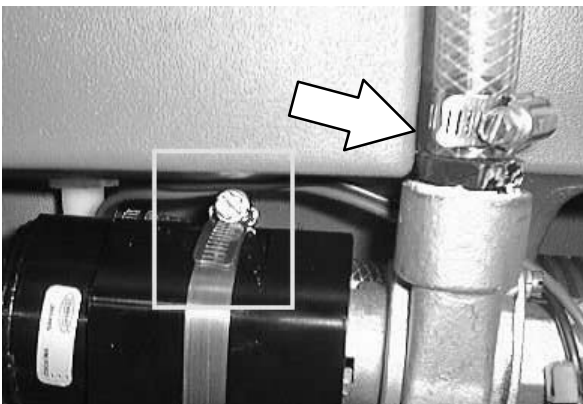

## ELECTRICAL

11. Reconnect the pump to the main electrical harness. See schematic in this section.

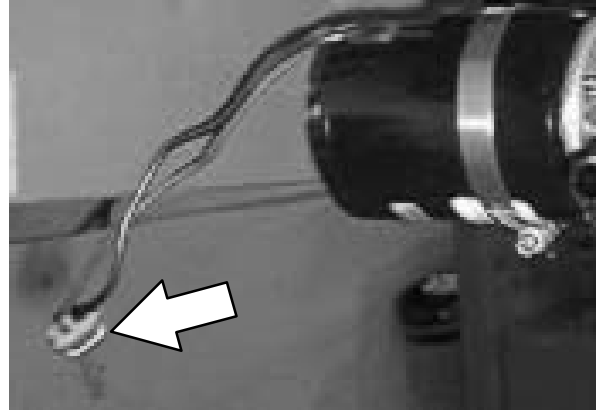

12. Reinstall the solution tank. See TO INSTALL SOLUTION TANK instructions in the scrubbing section.



13. Operate the machine and check the ES™ pump for proper operation.



---

**SOLUTION SOLENOID VALVE**

---

The solution solenoid valve is used to start and stop the flow of water to the scrub head when the machine is either propelling forward or in neutral. This valve is used along with the manual valve, which controls the amount of water that flows to the scrub head.

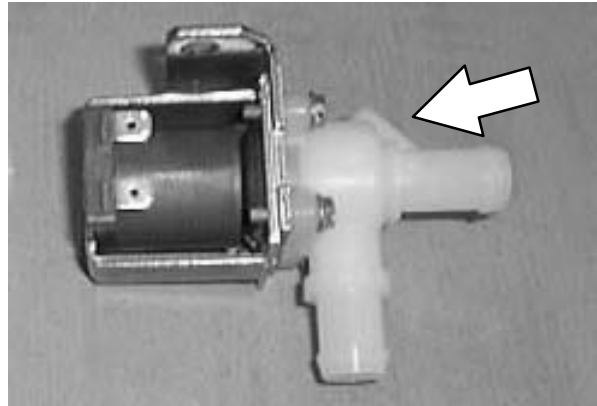
**TO REPLACE SOLUTION SOLENOID VALVE**

1. Drain the solution tank.

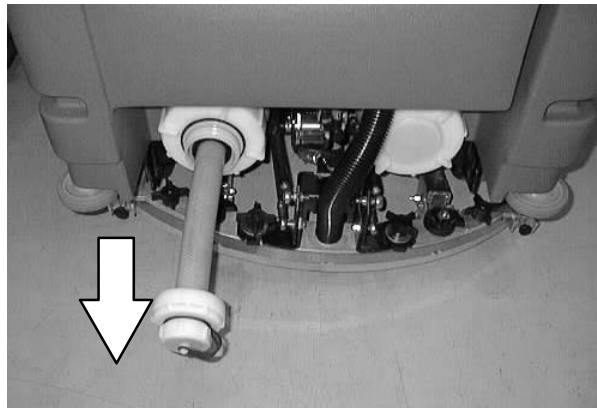

2. Lower the scrub head to the floor.

**FOR SAFETY: Before Leaving Or Servicing Machine; Stop On Level Surface, Set Parking Brake.**



## ELECTRICAL

3. Go under the machine on the right side, in front of the rear tire.



4. Locate the solution solenoid valve in the area of the manual valve.

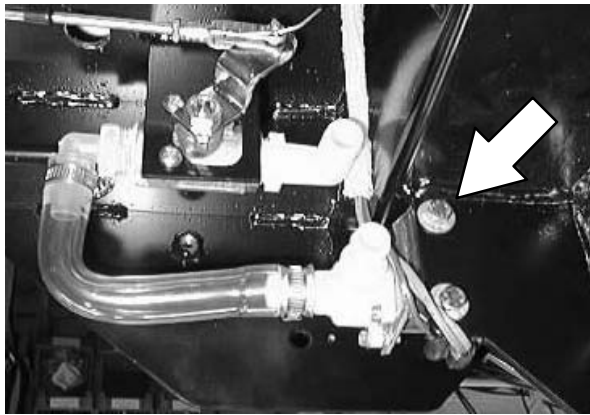

5. Mark and disconnect the wires leading to the solenoid valve.

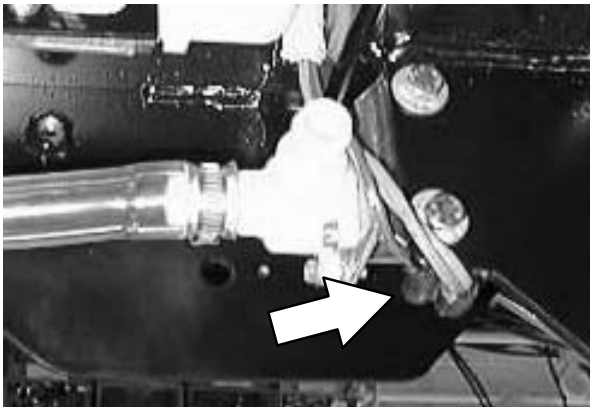

6. Loosen the two worm drive clamps holding the water hoses to the valve. Mark the hoses and pull them off the fittings.

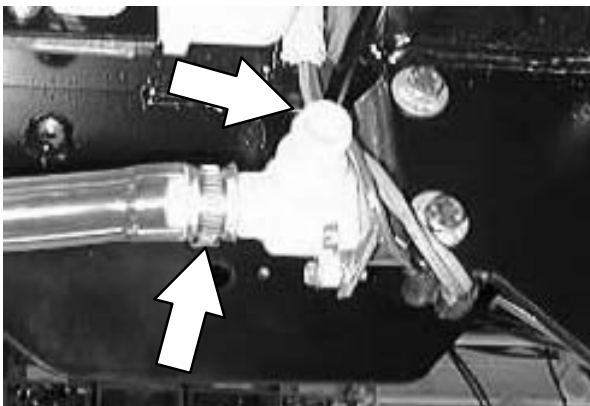

7. Remove the two screws holding the valve to the machine frame. Remove the valve from the machine.

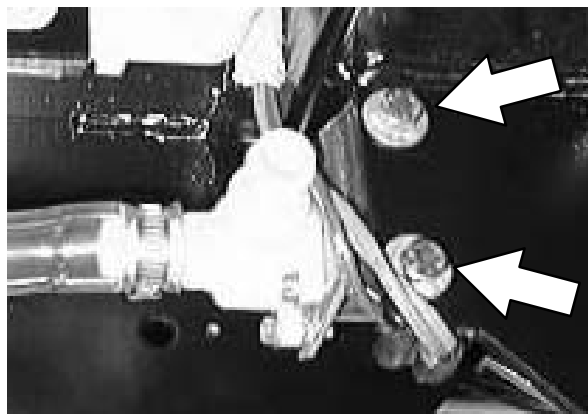

8. Position the new solenoid valve in the machine. Reinstall the hardware and lightly hand tighten.

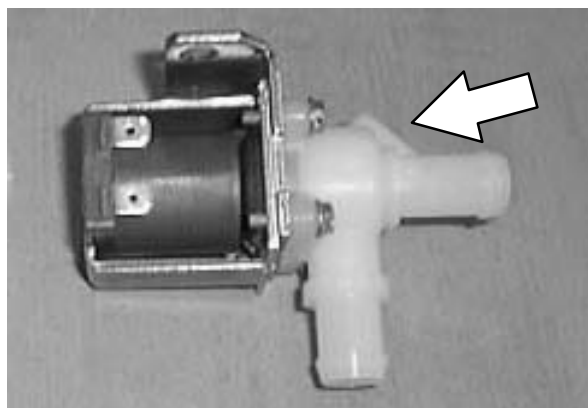

9. Re-connect the two water hoses to the new valve. Hand tighten the two worm drive clamps.

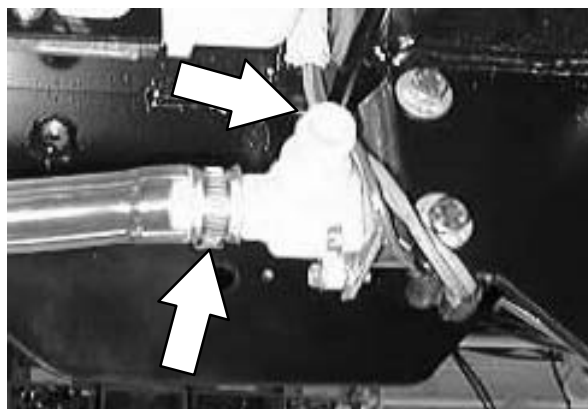

10. Re-connect the wires to the new solenoid valve. See schematic in the section.

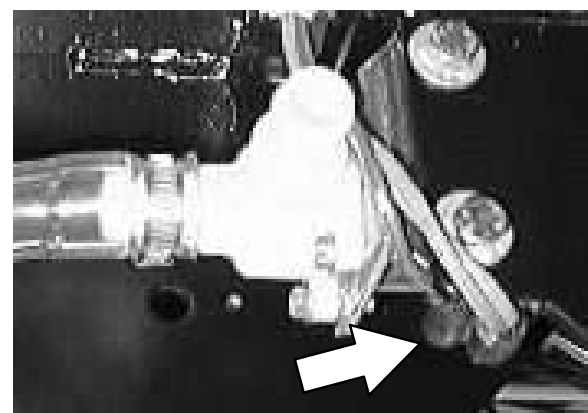

11. Start the machine and operate. Check the new valve for proper operation.

## VACUUM FAN

The vacuum fan, when activated, creates air flow in the recovery tank. With the recovery tank cover closed, the air flow from the vacuum fan creates vacuum at the squeegee hose. This vacuum pulls water from the lowered squeegee into the recovery tank.

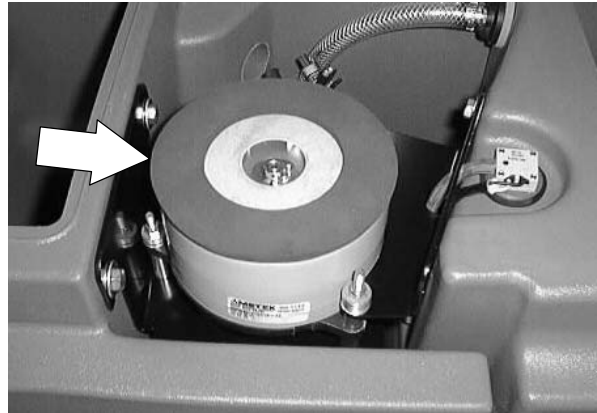

### TO REPLACE VACUUM FAN

**FOR SAFETY: Before Leaving Or Servicing Machine; Stop On Level Surface, Set Parking Brake.**

1. Remove the vacuum fan assembly from the machine. See TO REMOVE VACUUM FAN ASSEMBLY instructions in the SCRUBBING section.

*NOTE: Make sure to note the position of the vacuum fan exhaust outlet when removing the fan from the housing.*

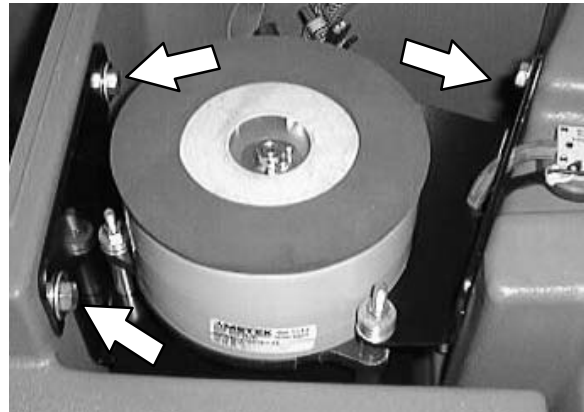

2. Remove the three screws and sleeves holding the vacuum fan to the mount bracket. Remove the vacuum fan.

*NOTE: Make sure to install a gasket on the bottom of the new fan.*

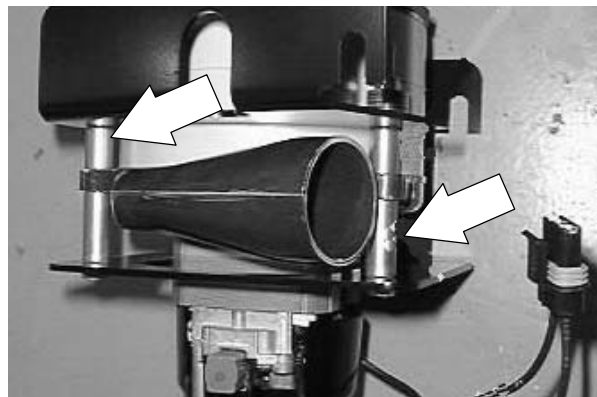

3. Position the new fan on the housing in the same orientation as the old fan.

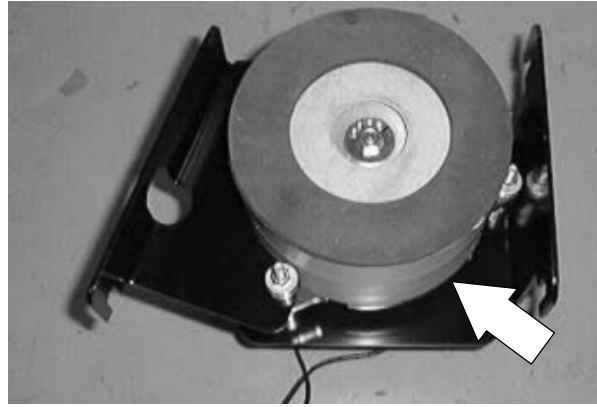

4. Reinstall the three screws and sleeves. Tighten to 8 – 10 Nm (6 – 7 ft lb).

*NOTE: On a machine equipped with the HD vacuum fan option, there are two fans.*

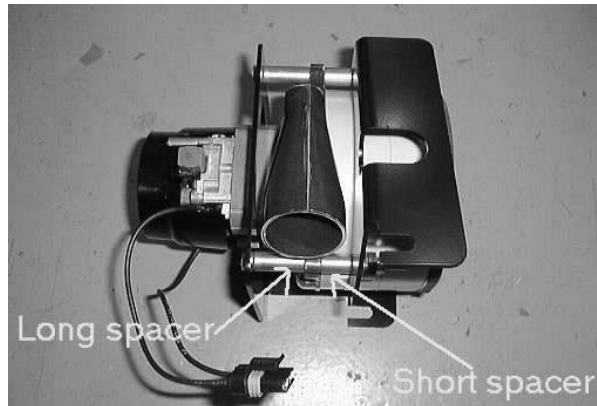

5. Reinstall the vacuum fan assembly in the machine. See TO INSTALL VACUUM FAN ASSEMBLY instructions in the SCRUBBING section.

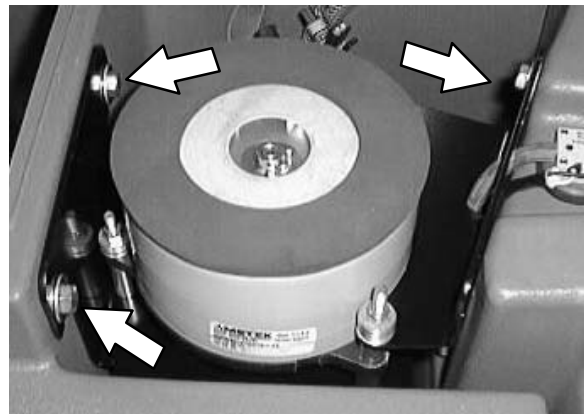

## ELECTRICAL

### TO REMOVE ROLLOUT BATTERY

The *rollout battery* allows the operator a quick and easy way to remove and replace the batteries from the machine.

1. Drive the machine to a flat, dry surface.
2. Turn the machine power off and set the parking brake.

**FOR SAFETY: Before leaving or servicing machine, stop on level surface, set parking brake, turn off machine, and remove key.**

3. Lift the operator seat to access the batteries. The support arm automatically engages when the seat is lifted all the way up.
4. Unplug the machine connector from the batteries.

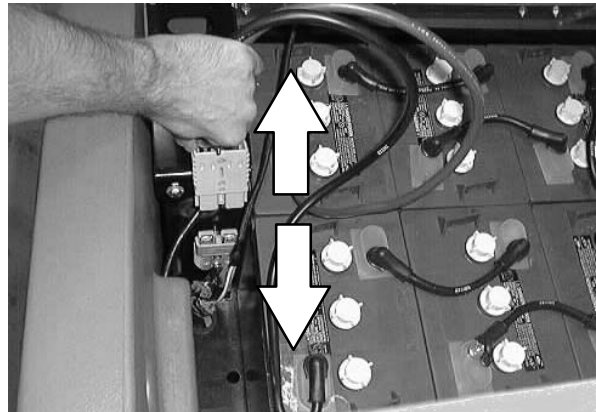

5. Push the battery cart to the right hand side of the machine. Line up the battery cart locks and the tabs on the machine. Push the battery cart forward.

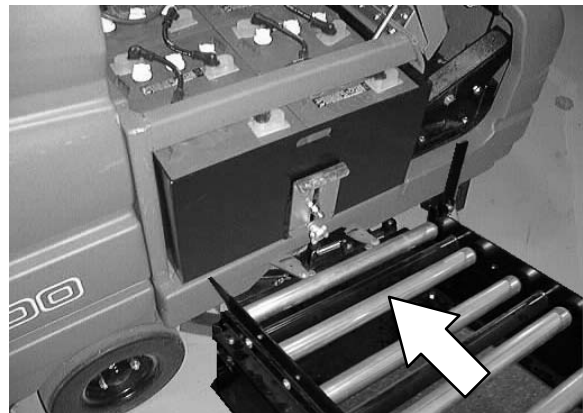

6. Lock the battery cart to the machine by closing the battery cart locks around the machine tabs.

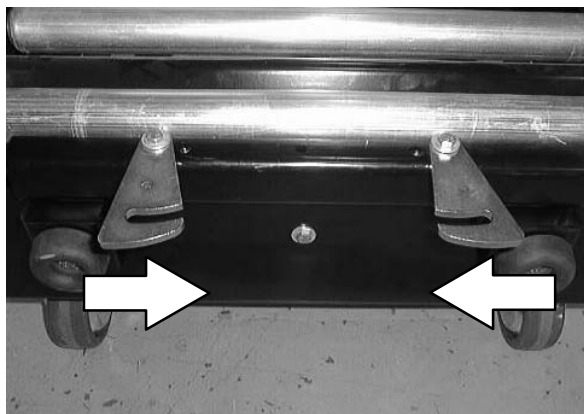

7. Set the battery cart floor lock by stepping down on the left side of floor lock.



8. Adjust the battery cart rollers before rolling out the batteries. The battery cart rollers must be the same height as the machine battery rollers.

Raise battery cart rollers: With a wrench, loosen the jam nut and turn the bolt clockwise. Then tighten the jam nuts.

Lower battery cart rollers: With a wrench, loosen the jam nut and turn the bolt counter-clockwise. Then tighten the jam nuts.

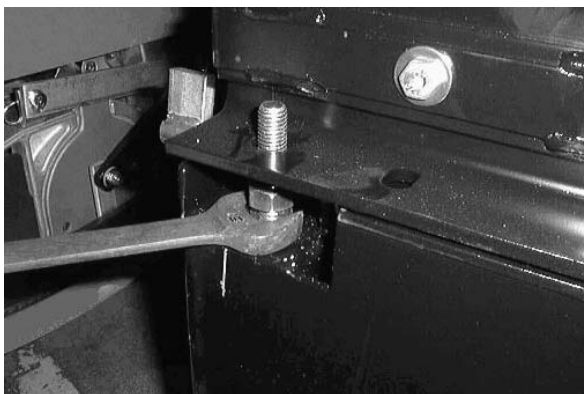

9. Turn the knob on the machine's battery latch plate counter-clockwise until the latch plate is free to move.

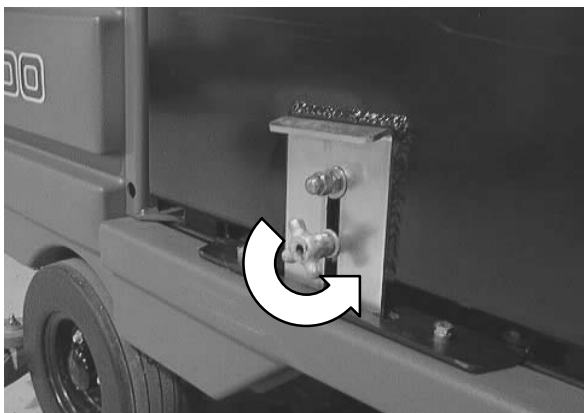

## ELECTRICAL

10. Raise the battery latch plate up out of the securing slot.

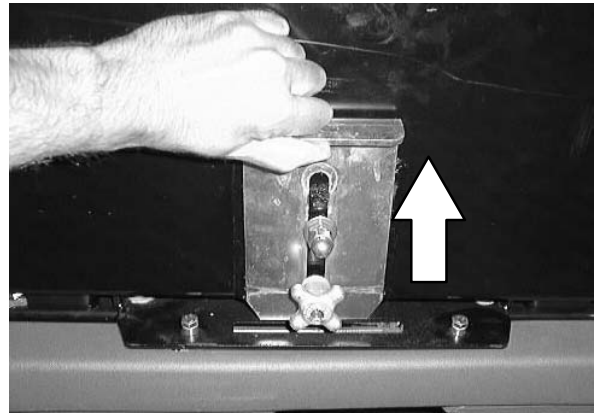

11. Raise the cart's battery stop bar by pushing down on the handle.



12. Grab the battery case slot and pull the battery case onto the battery cart.

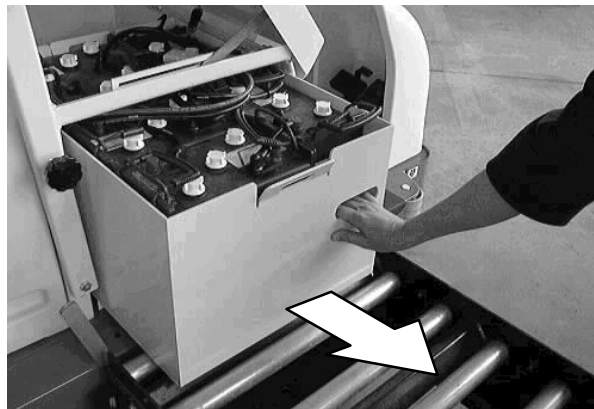

13. Lower the cart's battery stop bar by pulling up on the handle. This will keep the batteries from rolling off the cart when moving.

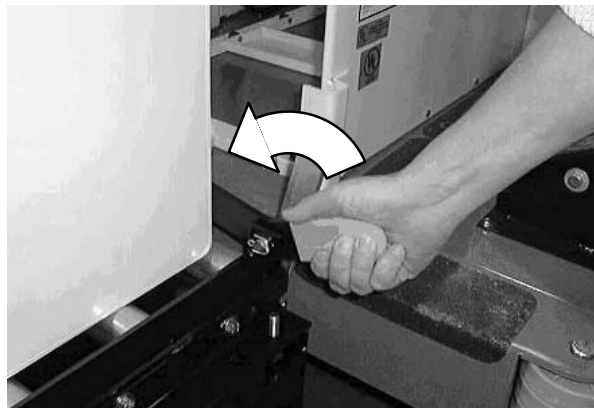



14. Release the battery cart from the machine by pushing the battery cart locks towards the outside of the battery cart.



15. Release the battery cart floor lock. To release floor lock, step down on the right side of floor lock.

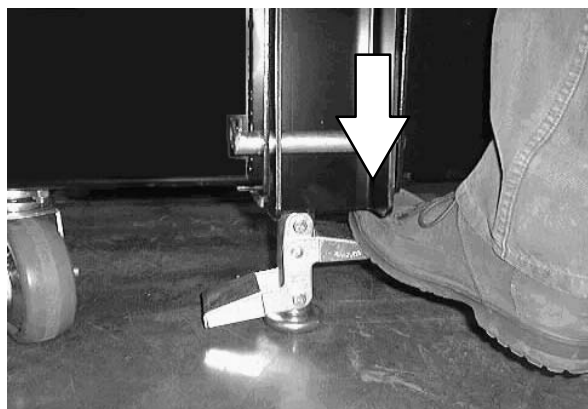

16. Pull the battery cart away from the machine.

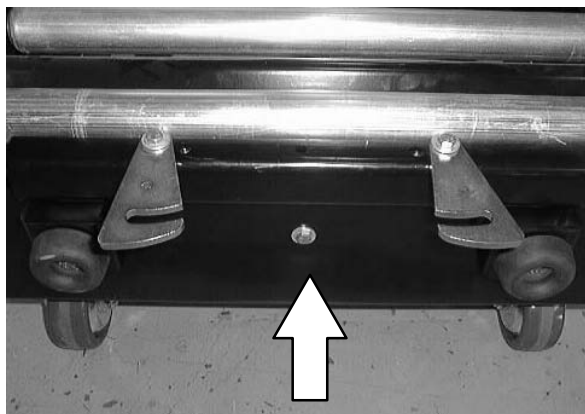

17. Reverse the previous steps to re-install batteries in the machine.



Fig. 1 - Electrical Schematic (S/N 7100xxx02700- )

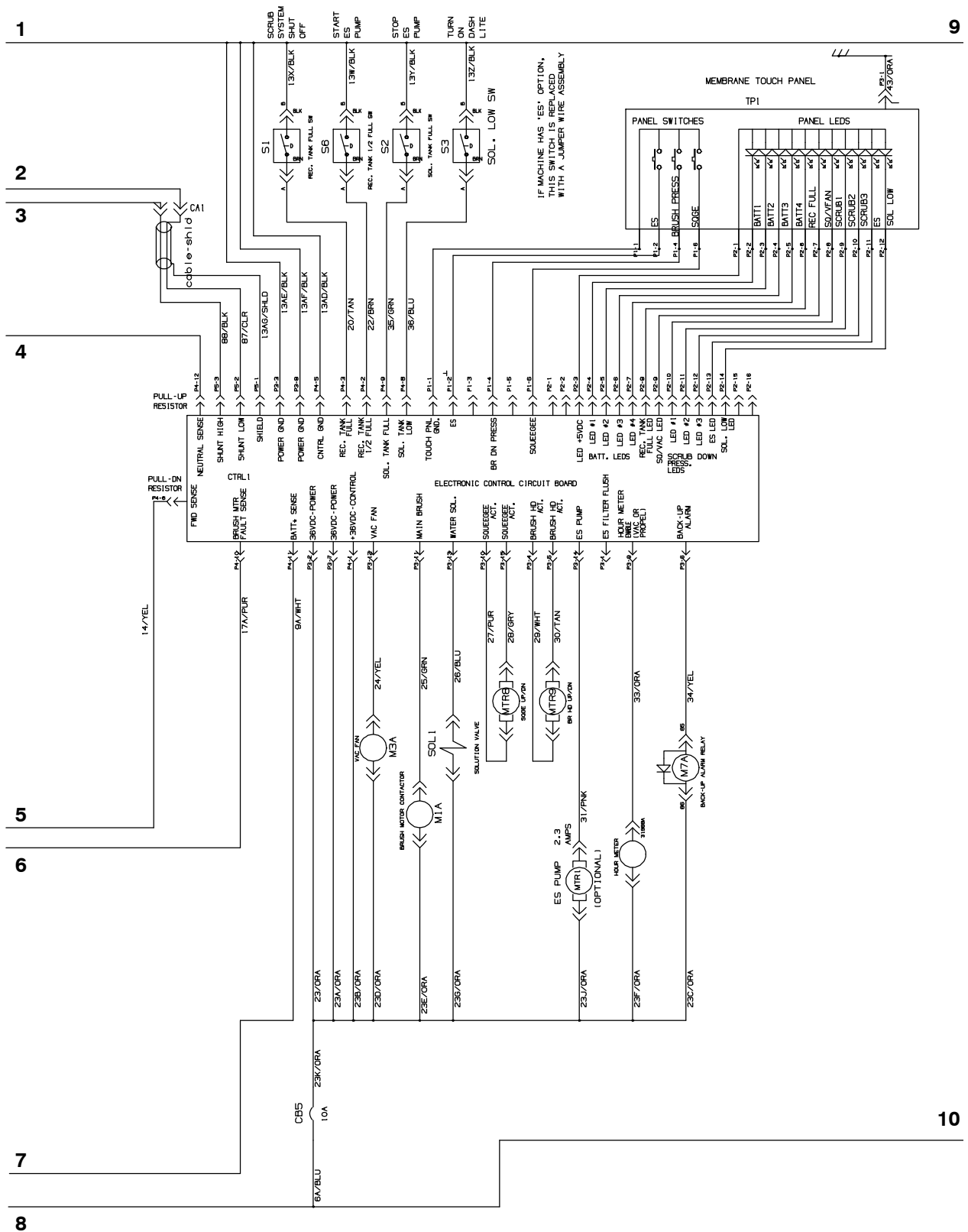
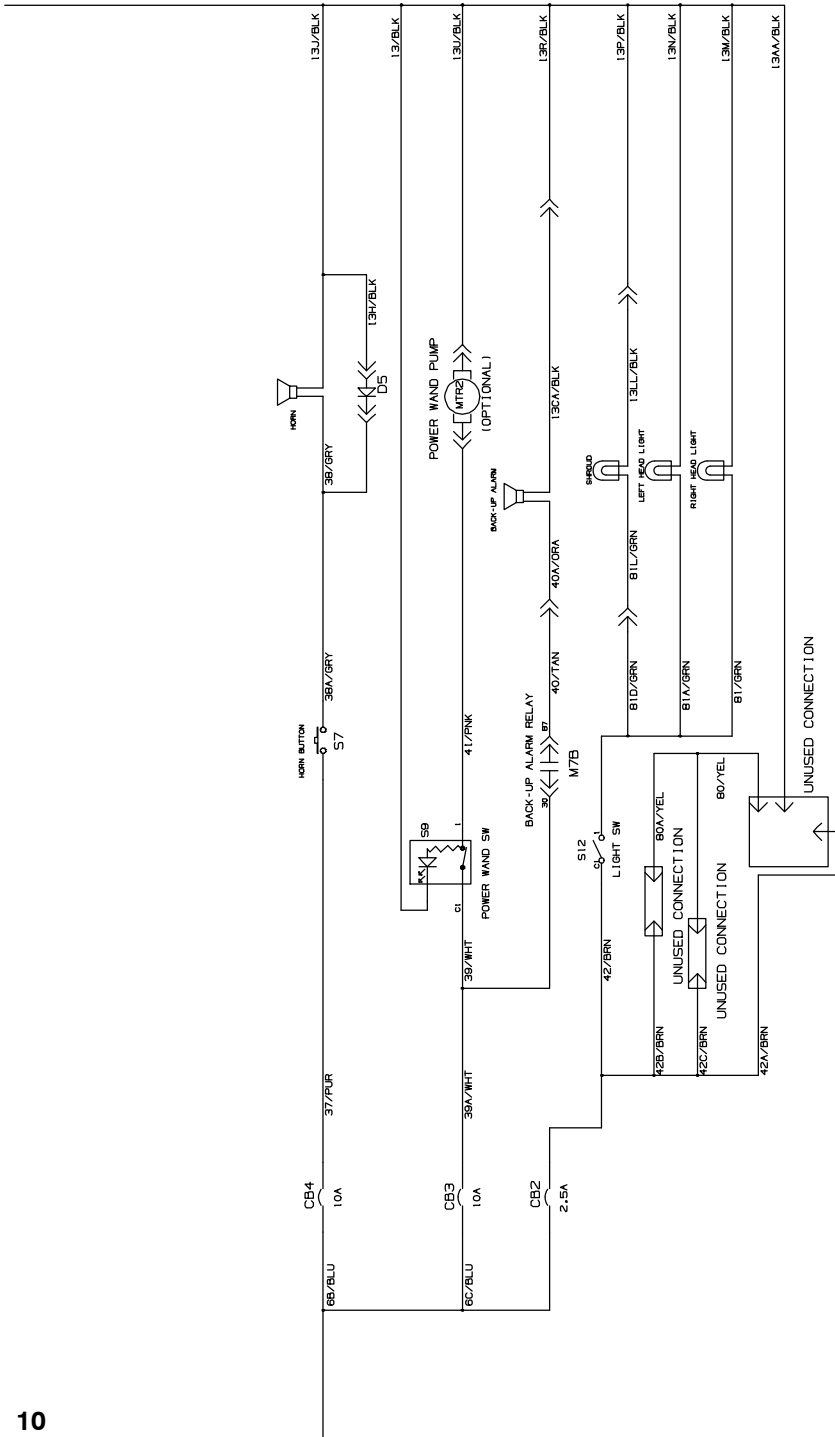

Fig. 1 – Electrical Schematic (S/N 7100xxx02700– )

9



10

Fig. 2 – Electrical Schematic (S/N 7100xxx00001–02699)

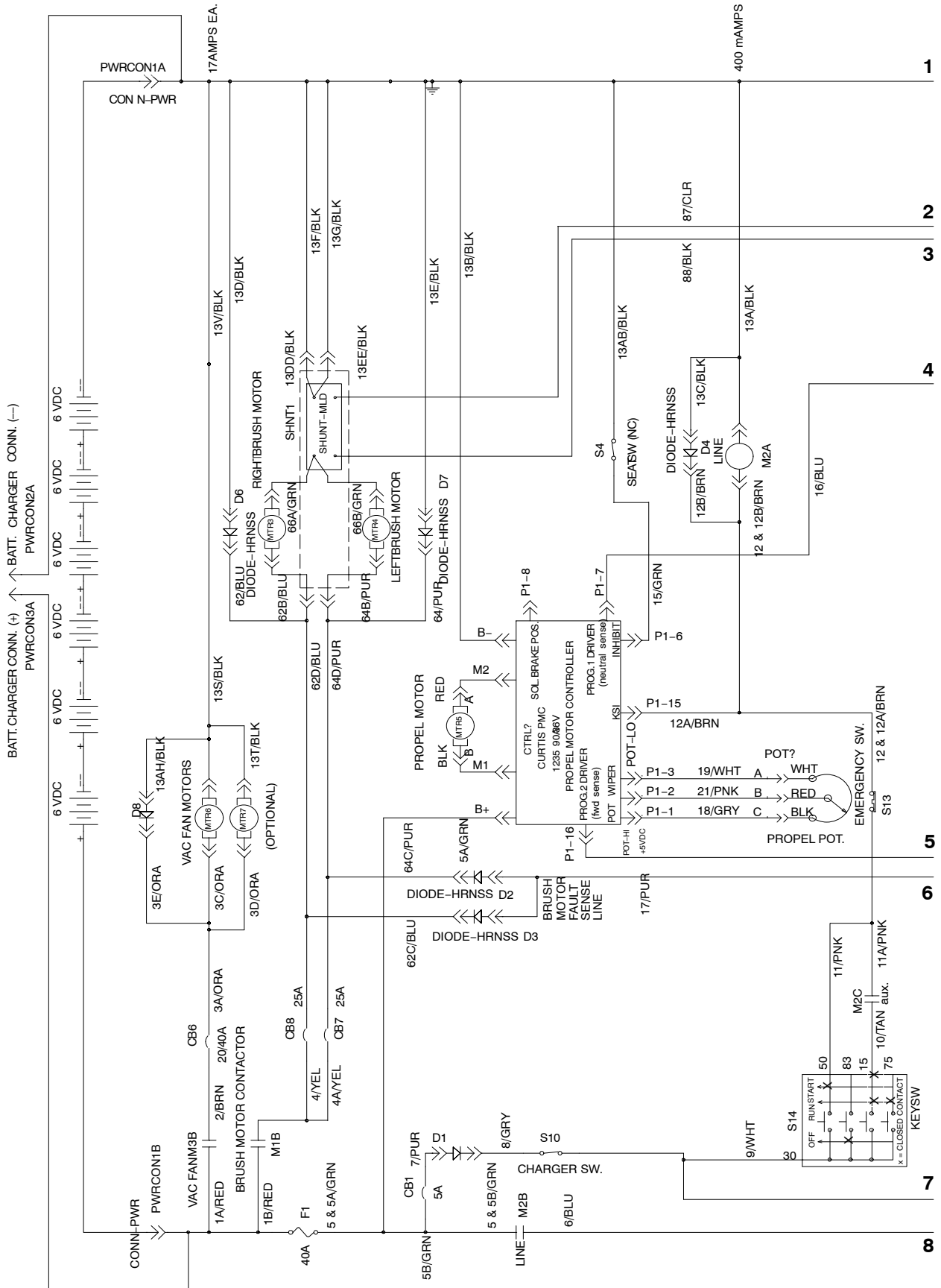

Fig. 2 - Electrical Schematic (S/N 7100xxx00001-02699)

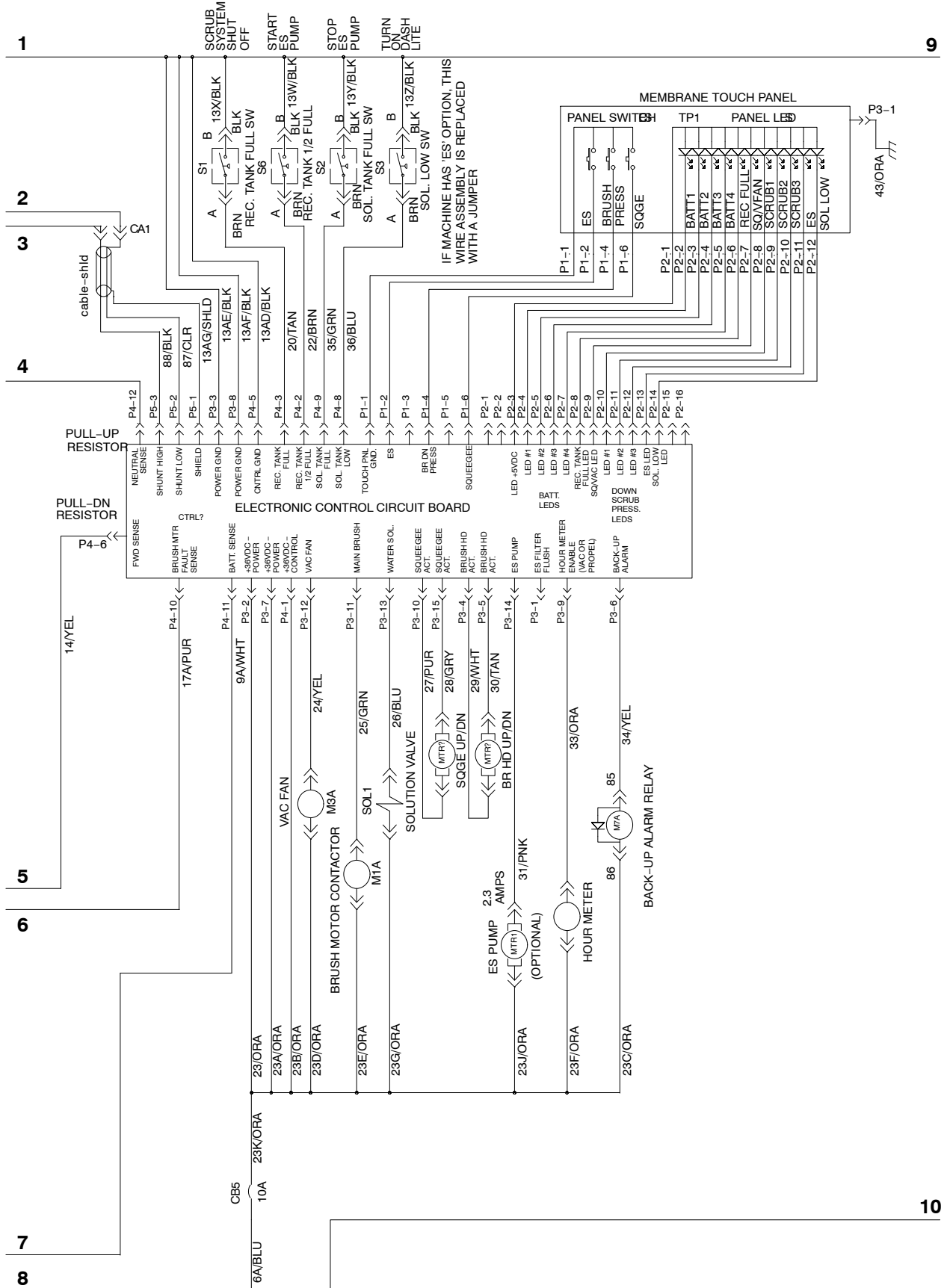
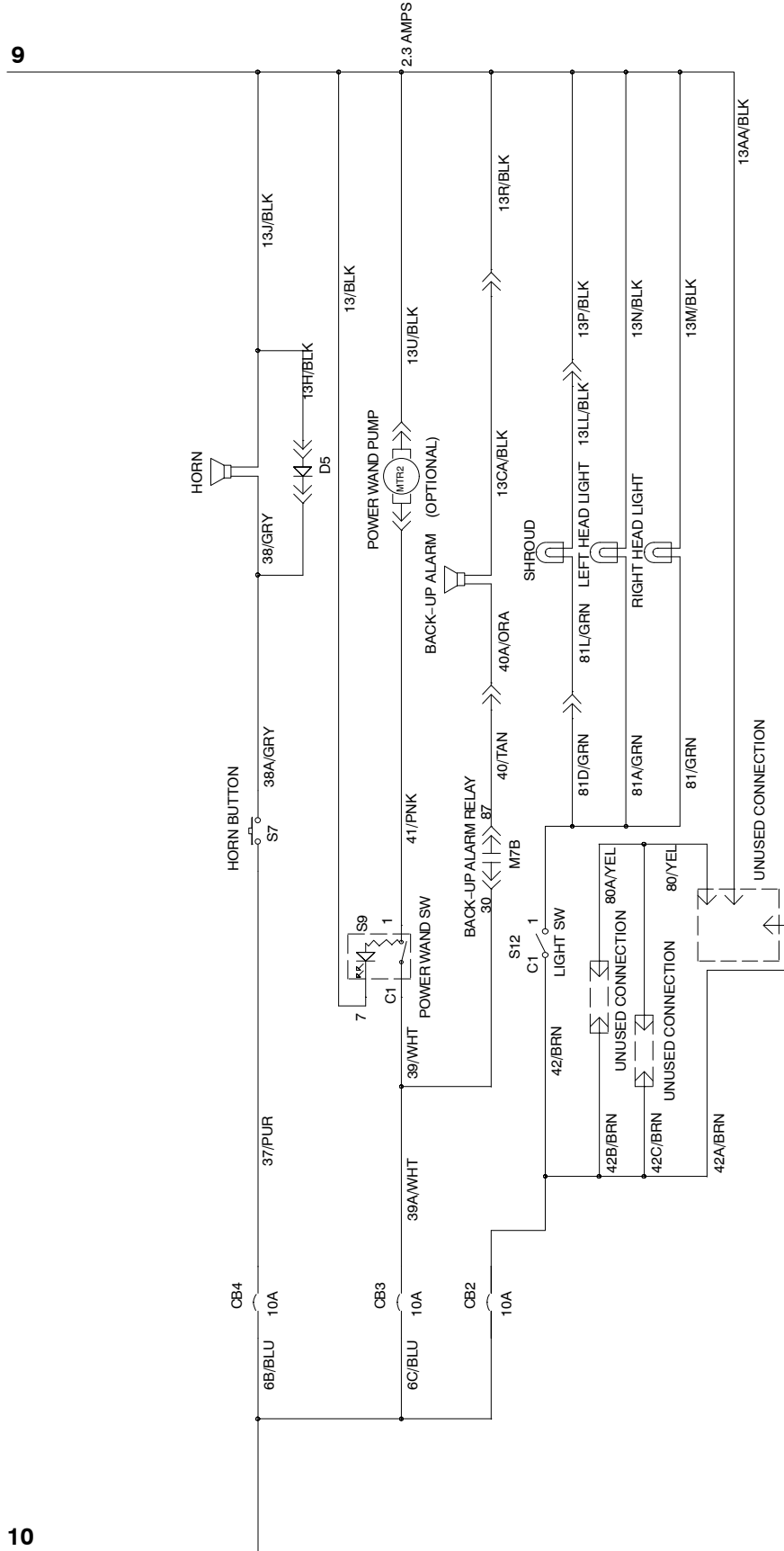

Fig. 2 – Electrical Schematic (S/N 7100xxx00001–02699)



9

10





Fig. 3 - Wire Harness Group (S/N 7100xxx02700- )

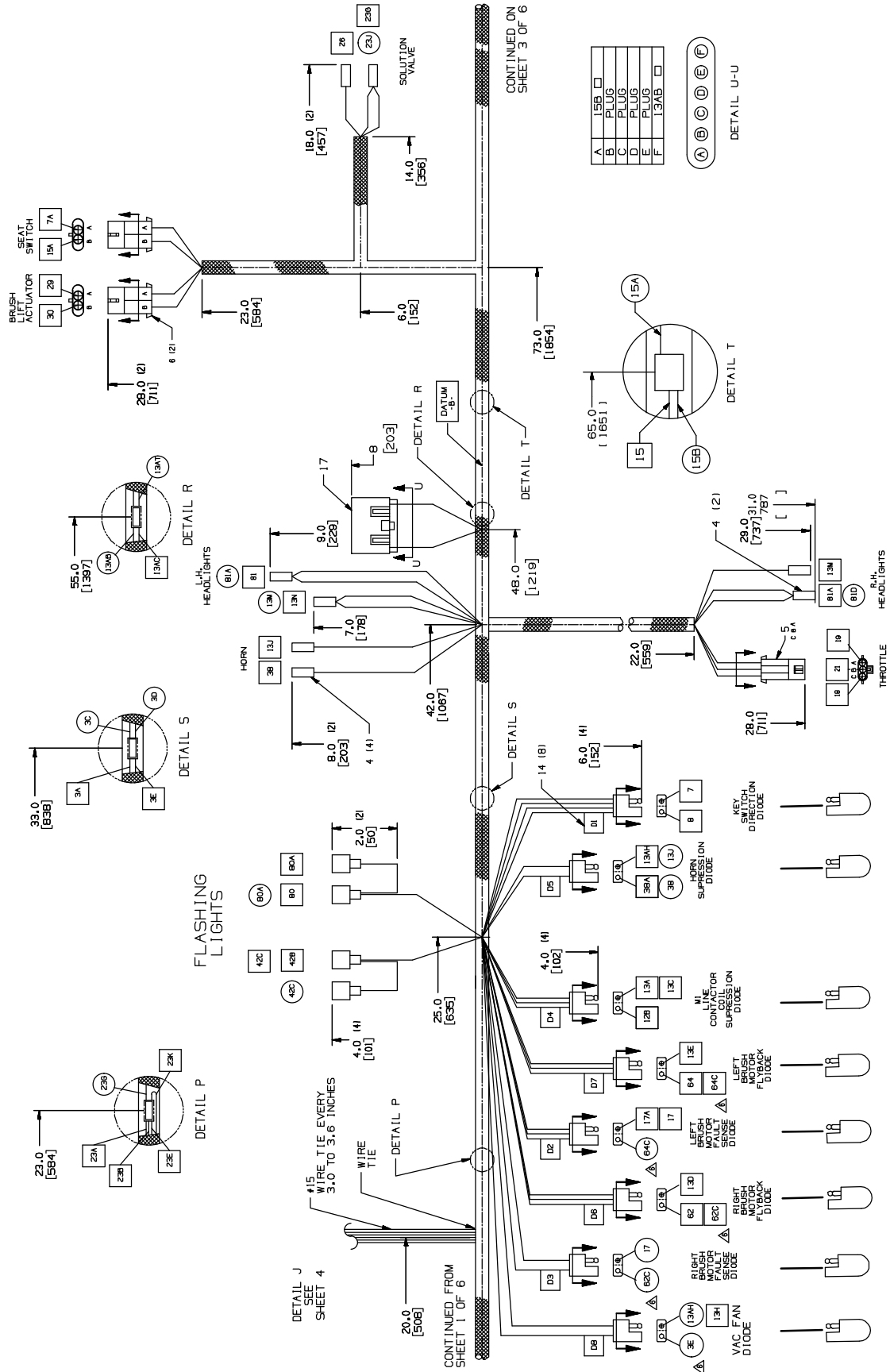

Fig. 3 - Wire Harness Group (S/N 7100xxx02700- )

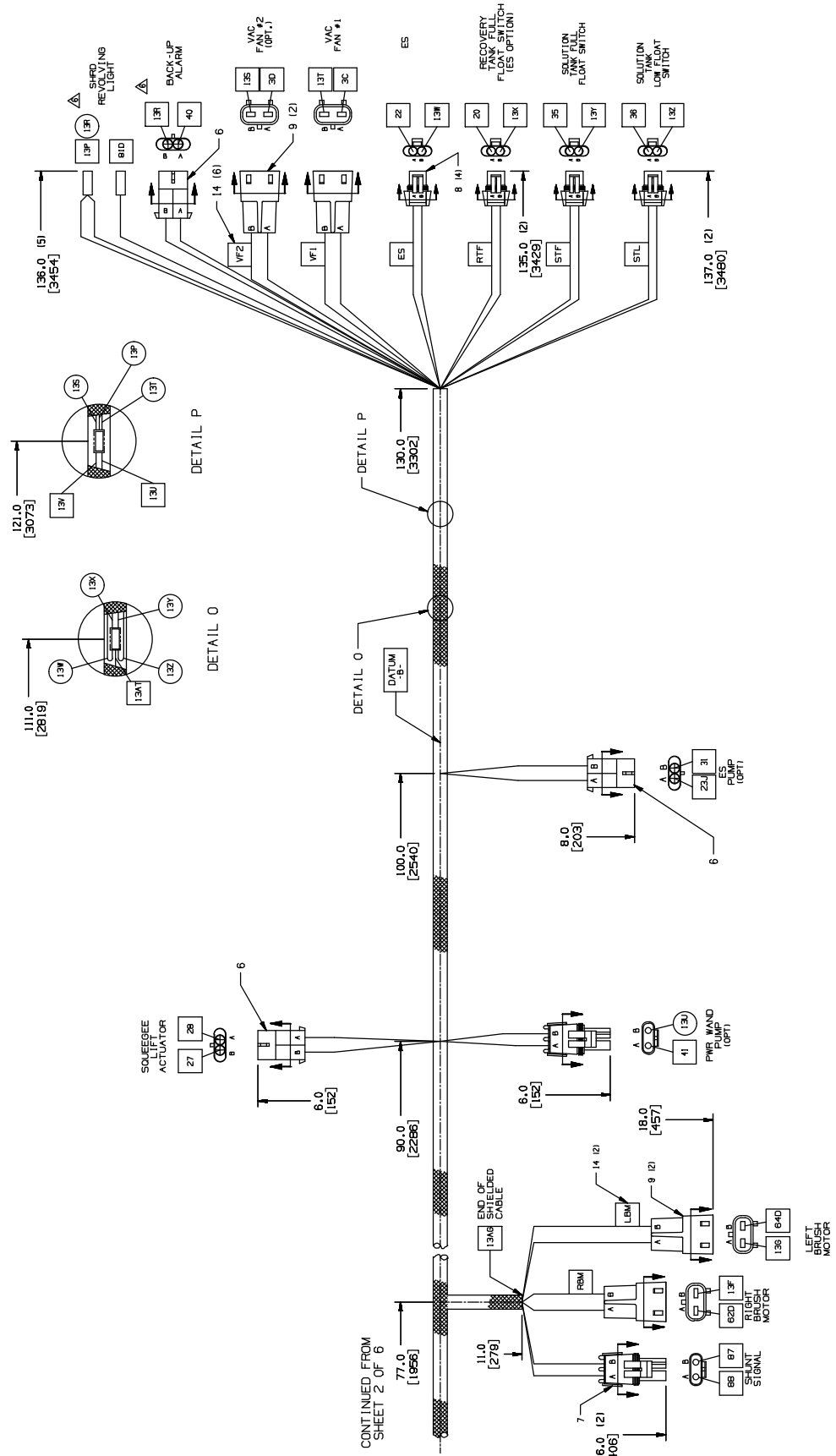

Fig. 3 - Wire Harness Group (S/N 7100xxx02700- )

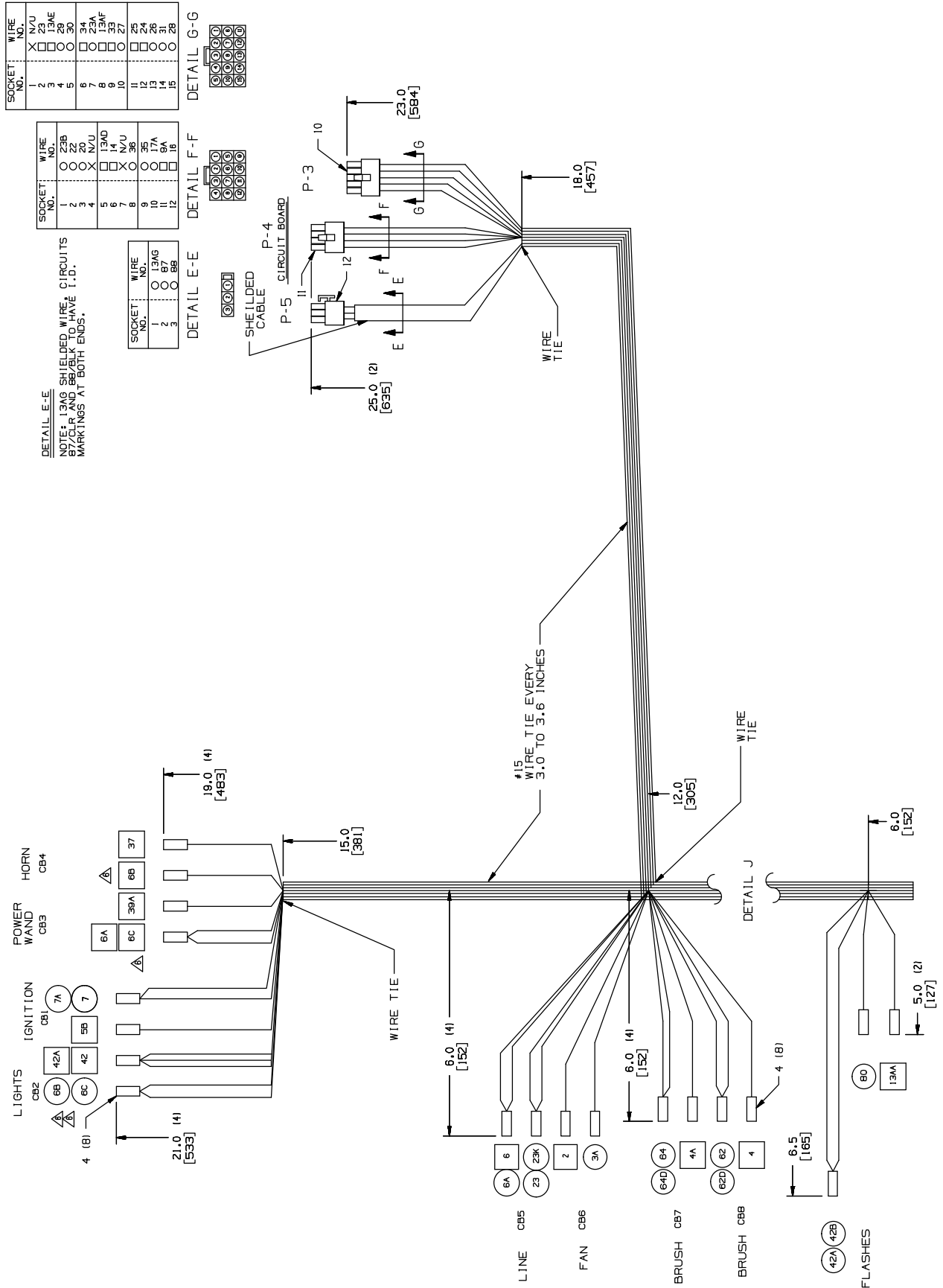



Fig. 4 - Wire Harness Group (S/N 7100xxx00001-02699)

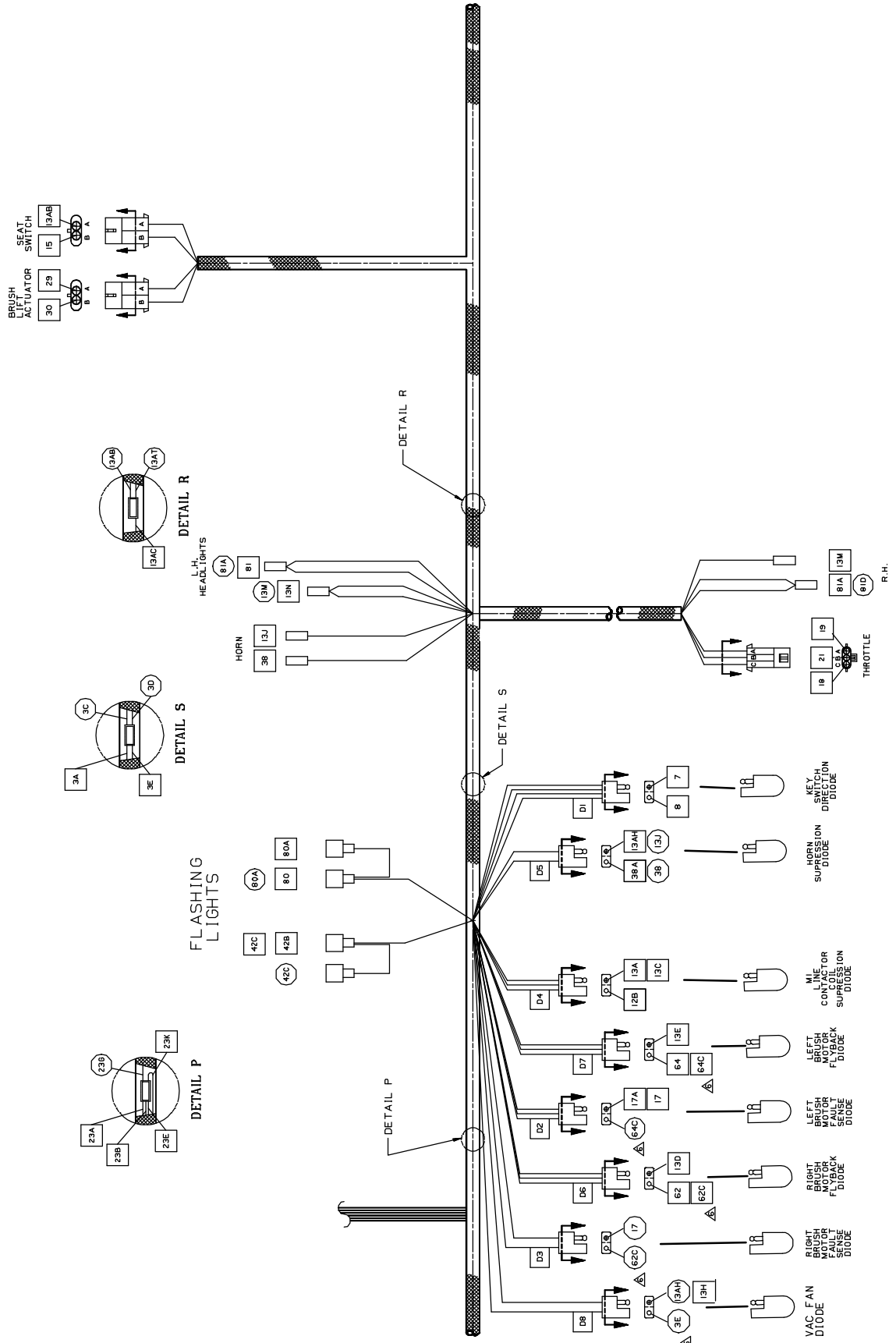

Fig. 4 - Wire Harness Group (S/N 7100xxx00001-02699)

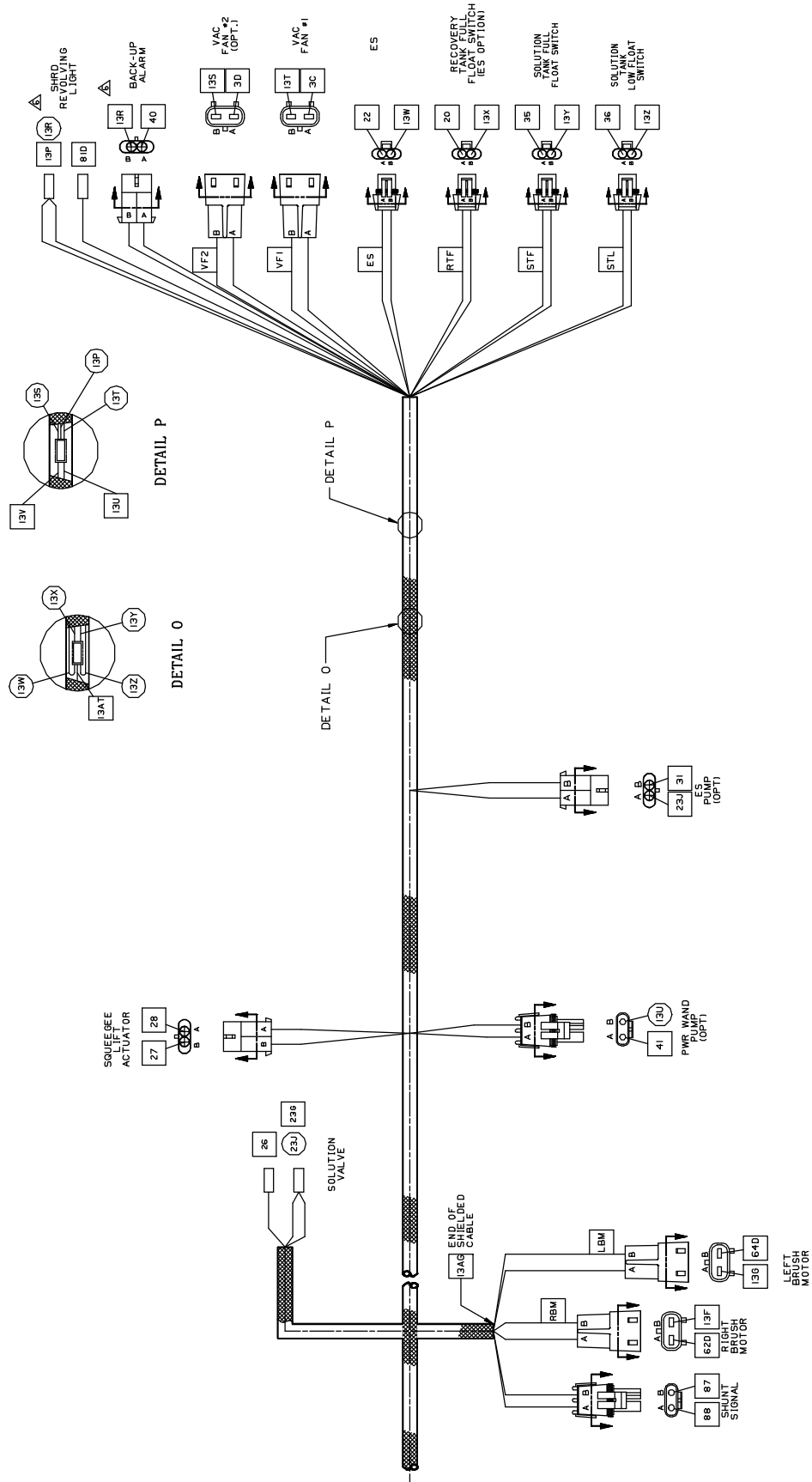

Fig. 4 - Wire Harness Group (S/N 7100xxx00001-02699)

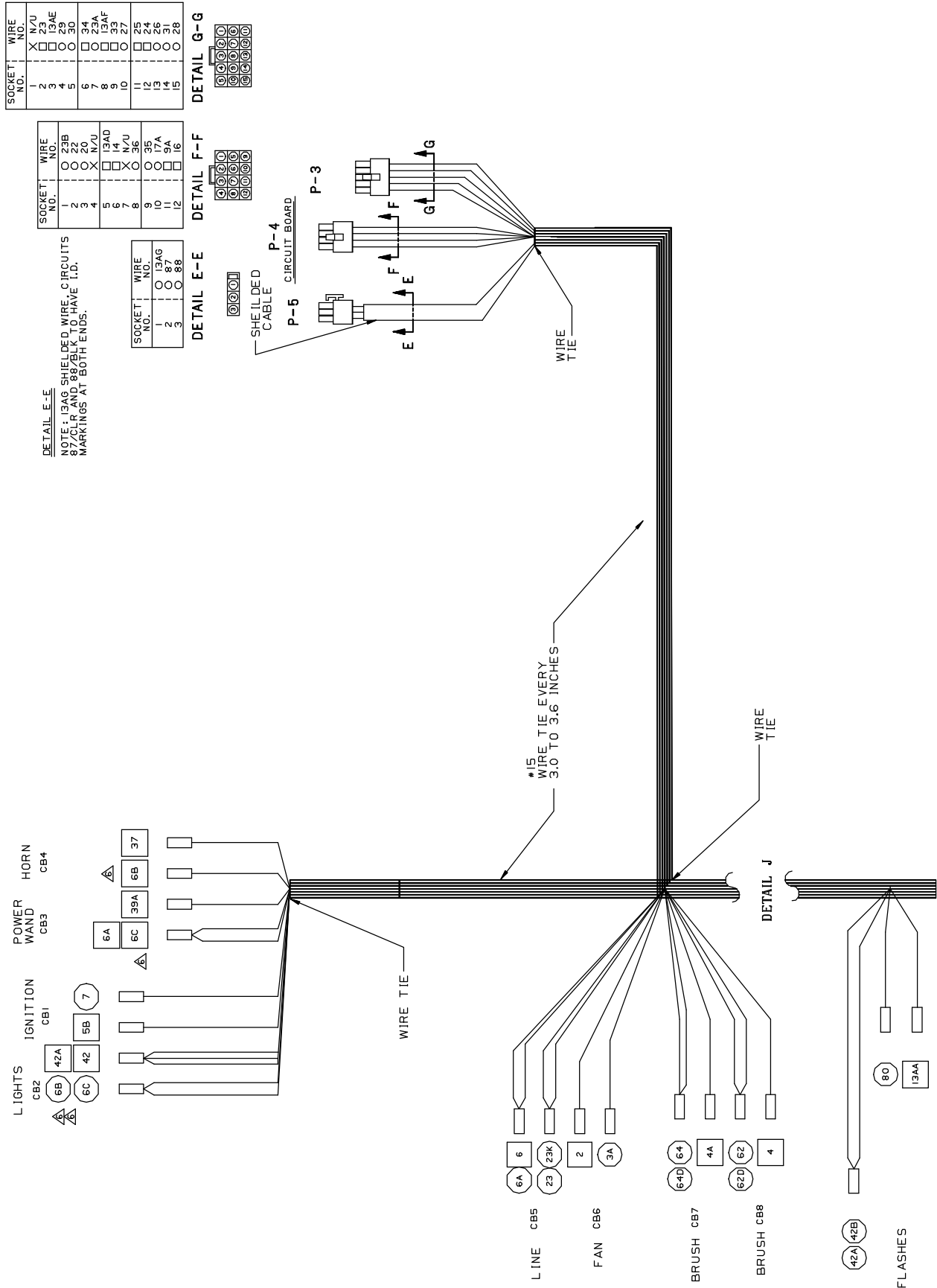
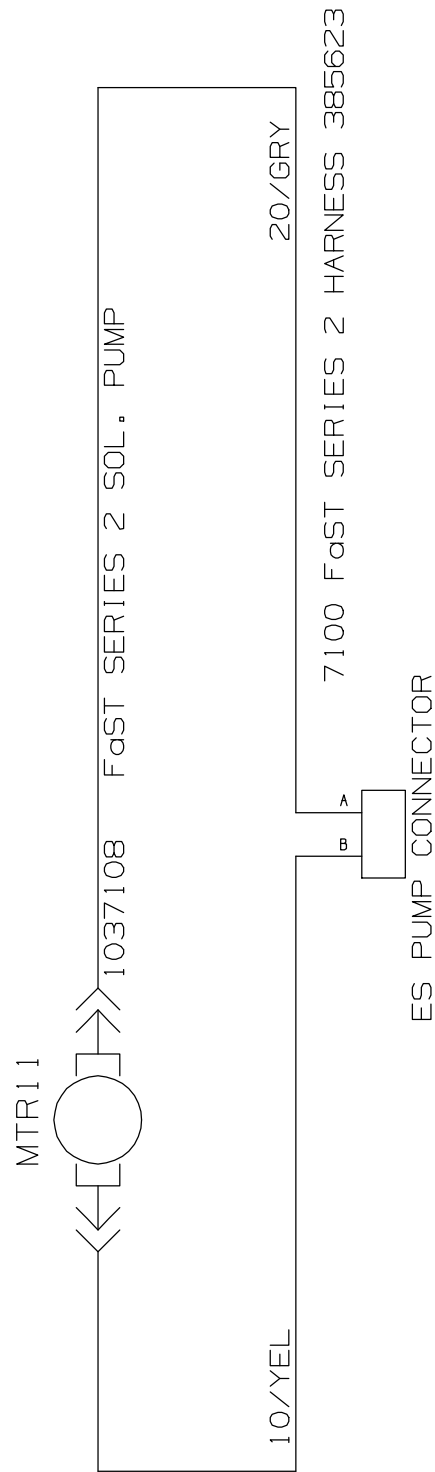

Fig. 5 - FaST Electrical Schematic (S/N 7100xxx01709- )





## OPERATING MODES

The Model 7100 has 7 different operating modes. The machine operator can access each mode by pressing various buttons on the control panel, holding them, and turning on the key. The common operating modes are detailed in the following charts.

The 7100 can be powered up in two different modes: normal mode (default), and maintenance mode. The normal mode is used for primary operation of the machine. The maintenance mode is used to select from 4 maintenance operations.

Operating Modes	Entry Sequence (how to activate)
* <b>Normal Mode</b> ; <i>Normal operation.</i> More info pages 4–82 thru 4–87	Default (when key is turned on)
* <b>Maintenance Mode</b> ; <i>Put machine into one of 4 maintenance modes.</i>	<ol style="list-style-type: none"> <li>1. While holding the squeegee button, turn the key to the start position and then release it.</li> <li>2. Keep holding the squeegee button until scrub pressure LED #3 is lit and then release it.</li> </ol>
* <b>Self Test Mode</b> ; <i>Test controller, actuators, and scrub brush motor operation. In this mode, the scrub pressure LED #3 will blink.</i> More info pages 4–88 thru 4–91	<ol style="list-style-type: none"> <li>1. Place the machine in maintenance mode</li> <li>2. Press and release the scrub button until pressure LED #3 is on.</li> <li>3. Press and release the squeegee key.</li> </ol>
* <b>Manual Mode</b> ; <i>Manually operate discrete functions without interlocks. In this mode, the battery LED #3 will blink.</i> More info pages 4–92 thru 4–95	<ol style="list-style-type: none"> <li>1. Place the machine in maintenance mode</li> <li>2. Press and release the scrub button until pressure LED #2 is on.</li> <li>3. Press and release the squeegee key</li> </ol>
* <b>Input Display Mode</b> ; <i>Display the state of floats, limit switches, and sensors. In this mode, battery LED #1 will blink.</i> More info pages 4–96 and 4–97	<ol style="list-style-type: none"> <li>1. Place the machine in maintenance mode</li> <li>2. Press and release the scrub button until both scrub pressure LED's #2 &amp; #3 are on.</li> <li>3. Press and release the squeegee key</li> </ol>
* <b>Restricted Down Pressure Mode</b> ; <i>Toggles the machine between a normal and a restricted down pressure setting.</i> More info pages 4–98	<ol style="list-style-type: none"> <li>1. Place the machine in maintenance mode</li> <li>2. Press and release the scrub button until scrub pressure LED #1</li> <li>3. Press and release the squeegee key</li> </ol>
* <b>Software Date Display Mode</b> ; <i>Flashes the current software date code via the touchpanel LED's</i> More info pages 4–99	<ol style="list-style-type: none"> <li>1. Place the machine in maintenance mode</li> <li>2. Press and release the scrub button until both scrub pressure LED's #1 &amp; #3 are on.</li> <li>3. Press and release the squeegee key</li> </ol>

Operating Mode	Entry Sequence (how to activate)
Normal Mode; <i>Normal operation.</i>	Default (when key is turned on)

## NORMAL MODE

The purpose of the normal mode is for the general operation of the machine. The machine will normally start in this mode. What follows is a brief description of each of the operations in the normal mode.

## SCRUB BUTTON

The purpose of the scrub button is to turn the scrubbing operations on and off and adjust the scrubbing down pressure. Pressing the scrub button while the scrubbing operation is currently inactive will initiate the following actions:

1. Illuminate the LED's that indicate the default down pressure.
2. **If the machine is not in reverse**, the vacuum fan will turn on, the squeegee will drop, and the brushes will drop. Putting the machine into reverse will raise the squeegee and, after a slight delay, turn off the vacuum fan.
3. **If the machine is in forward**, the brush head will drop, water valve will turn on, and the brushes will start turning. Putting the machine into neutral while scrubbing will turn off the brushes, turn off water, and, after a short delay, slightly raise the scrub head.
4. If the operator holds the scrub button after the LED's become illuminated, the machine will begin to scroll through the different scrub down pressures. The controller stores the pressure displayed as the new default after the user releases the scrub button.

Pressing and releasing the scrub button while the machine is currently in the scrub mode will initiate the following actions.

1. The scrub motors will turn off, the water valve will close, and the scrub head will start to raise.
2. The machine will delay a few seconds and the squeegee will start to raise.
3. The vacuum fan will turn off after a slight delay.

## SCRUB PRESSURE DOWNSHIFT FEATURE

This machine has a scrub pressure downshift feature. This feature is designed to protect the scrub actuator in the event that the scrub brushes cannot be loaded enough to satisfy the minimum currents for downpressure 2 or 3.

This feature will be invoked automatically if the circuit board detects a stall condition for the scrub head actuator while adjusting down to meet the minimum current condition. When in this mode, the controller will reload the scrub pressure levels to the next lightest down pressure.

1. If the machine is in down pressure 3, the system will downshift to down pressure 2.
2. If the controller cannot meet the minimum current to down pressure 2, it will downshift to down pressure 1.
3. The current down pressure level is indicated using blinking LED's. If the machine was operating in downpressure 3 and downshifts to downpressure 2, all three LED's will be lit, and the lower two will blink.
4. If the system downshifts to downpressure 1, the lowest down pressure LED will blink.

This system will reset itself each time the machine goes into neutral. If the system had downshifted into pressure 2 and the machine goes into neutral, the original down pressures will be re-loaded, and the panel LED's will go into there normal non-blinking state.

## SQUEEGEE BUTTON

Pressing the squeegee button will start or stop the water pickup operation. If the operator presses the squeegee button while the squeegee LED is currently not illuminated will cause the following actions:

1. The squeegee LED will be illuminated.
2. **If the machine is not in reverse**, the squeegee will drop and the vacuum fan will turn on. If the machine goes into reverse while the squeegee is active, the squeegee will rise. If the machine remains in reverse long enough, the vacuum fan will shut off.

Pressing the squeegee button while the squeegee LED is on will cause the following actions:

1. The squeegee LED will turn off.
2. The squeegee will raise.
3. The vacuum fan will turn off after a slight delay.

### ES™ BUTTON

Pressing the ES™ button will enable or disable the ES™ system. The ES™ system will draw water from the recovery tank, through a filter and pump it into the solution tank. If the operator has turned on the ES™ system, the recovery tank ES™ float becomes continuously active (about 3 sec), and the solution tank full float is open, the ES™ pump will begin to run. The ES™ pump will continue to run for about 30 seconds after the ES™ float becomes uncovered, or until the solution tank full float turns on.

### OVERFLOW FLOAT SWITCH

If the recovery tank becomes full, the overflow system will shut off the scrub and vacuum up system. If the overflow float switch becomes continuously active (about 3 seconds), the overflow light will turn on and latch. If the scrub or squeegee functions are active, they will become deactivated and the vacuum fan will turn off after a slight delay. If the operator presses the squeegee button, the squeegee will drop and the vacuum fan will run for about 30 seconds to pick up any excess water. The overflow indicator will not turn off by simply emptying the recovery tank. The overflow indicator will remain illuminated until at least one of the following action occur:

1. The overflow float switch becomes inactive and the scrub button is pushed.
2. The overflow float switch becomes inactive and an on/off/on keyswitch cycle is performed.

### SOLUTION LOW FLOAT SWITCH

When the solution low float switch is uncovered for more than three seconds, the solution low indicator will turn on. To turn off the solution low LED, the key switch must be cycled or the scrub function can be toggled on or off. At this point, if the solution low float switch remains ungrounded for more than three seconds, the solution low indicator will turn on again.

## BATTERY GAUGE

The battery gauge displays the state of charge of the batteries with a 4 segment LED display. When the last segment is blinking, the battery voltage is about 31-1/2 volts (80% discharge), and the batteries need charging. The scrub and squeegee functions will shut off if the operator is scrubbing at this point. If the user selects the squeegee button, squeegee will lower, and the vacuum fan will run for about 30 seconds to allow the operator to pick up any excess water. The squeegee will then lift, and the vacuum fan will shut off after a slight delay.

## HOUR METER

The hour meter logs hours if the machine is in one of the following modes.

1. Propelling
2. Vacuum fans running.

## INTERLOCKS

The 7100 has several interlocks which can inhibit or cancel machine functions.

- REVERSE – If the board does not sense an active forward sense (P4–6) or neutral sense (P4–12), the controller board will assume reverse. When this happens the following function will become inhibited:
  - SQUEEGEE will rise. When the operator disengages reverse, the squeegee function will resume.
- NEUTRAL –When the neutral input is active (P4–12), the machine will detect neutral. At this point, the following actions will occur. When the machine detects the forward switch, the functions will resume.
  - WATER VALVE will turn off.
  - 5 SECOND delay.If the machine is still in neutral after the 5 second delay:
  - SCRUB BRUSHES will turn off.
  - SCRUB HEAD will raise slightly.
- LOW BATTERY – The machine will cancel the following functions when the last battery LED is blinking (about 31.5 volts).
  - SCRUB FUNCTION– The scrub function will cancel as if someone toggled the scrub button. The operator cannot restart the scrub functions until the meter is reset. The operator can reset the battery gauge by unplugging the main battery connector.
  - SQUEEGEE AND VACUUM FAN–The machine will cancel squeegee operation, as if someone toggled the squeegee button. If the operator presses the squeegee button after being canceled, the squeegee and vacuum fan will resume operation for about 30 seconds.

**The operator will reset the battery meter each time the main battery connector is removed.**

Each time the operator powers down the controller, the machine will store the current state of battery charge. When the operator powers up the machine, it will recall the last state of charge, and display it on the touch panel. If the operator disconnects the main power connector, the controller will assume the machine has been charged. The battery meter will be reset the next time the key is turned on.

- **FULL RECOVERY TANK** – The 7100 will cancel the following functions if the recovery tank float switch is turned on:  
THE CONTROLLER will cancel scrub and squeegee operations, as if someone toggled the scrub or squeegee buttons.  
THE TANK FULL LED will start to blink. This message will not turn off by simply emptying the recovery tank. The LED will remain blinking until the machine is powered down, or the scrub button is pushed.
- **BRUSH MOTOR ERROR** – The controller will cancel the following functions if an open breaker opens during scrub motor operation:  
THE CONTROLLER will cancel scrub and squeegee operations, as if someone toggled the scrub or squeegee buttons. If the operator presses the squeegee button, squeegee and vacuum fan operation will resume. ALL THREE BRUSH PRESSURE LED'S will begin to blink, alerting the operator to the open breaker condition.

Operating Mode	Entry Sequence (how to activate)
<b>Self Test Mode;</b> <i>Test controller, actuators, and scrub brush motor operation. In this mode, the scrub pressure LED #3 will blink.</i>	<ol style="list-style-type: none"><li>1. Place the machine in maintenance mode</li><li>2. Press and release the scrub button until pressure LED #3 is on.</li><li>3. Press and release the squeegee key.</li></ol>

## SELF TEST MODE

The purpose of the Self Test Mode is to test the operation of the control board and to exercise all of its outputs. **When this mode is engaged, various motors and accessories will be engaged at full power as part of the test. Extreme care must be taken to be sure that technicians and bystanders are not injured as a result of this test.**

- **TO PREVENT INJURY, ALWAYS TURN THE MACHINE OFF AFTER THE DIAGNOSTIC MESSAGES HAVE BEEN DISPLAYED.**
- **IF THE DIAGNOSTIC MESSAGES DO NOT APPEAR, DO NOT ATTEMPT TO SERVICE THIS MACHINE WITHOUT FIRST TURNING IT OFF AND RETURNING TO ANOTHER MODE.**

The Self Test Mode tests each of the following controller board functions:

1. Squeegee actuator.
2. Scrub head actuator.
3. Scrub brush motor current.
4. Hour meter output.
5. Water valve output.
6. ES™ pump output.
7. Scrub brush contactor output.



When the operator releases the squeegee button, the controller will run the squeegee and the brush head actuators to the up positions. It will then run the following procedure:

1. Turn on the vacuum fan and lower the squeegee actuator.
2. Wait for the actuator to stall, flag error for always stalled, early stall, or never stalled.
3. Raise squeegee.
4. Drop scrub head about 2 inches.
5. Run head actuator up.
6. Wait for the actuator to stall, flag error for always stalled, early stall, or never stalled
7. Check brush motor current with brush motors off. Flag error for current sensed.
8. Turn on the brush motors.
9. Flag error for zero current, low current, or high current.
10. Turn off the brush motors.
11. Cycle and test the ES™ pump output.
12. Cycle and test the Vacuum fan output.
13. Cycle and test the Scrub brush motor output.
14. Cycle and test the Hour meter output.
15. Cycle and test the water valve output.
16. The ES/FaST and squeegee LEDs will flash green for system passed, turn on the overflow light (red) or solution empty LED (red) for system failed.

**SELF TEST ERROR CODES**

To interrogate the machine to determine the nature of a diagnostic failure, the operator must use the buttons on the instrument panel. We have associated a group of error codes to each button on the instrument panel. If the operator presses the button assigned to a group that has sensed an error, the controller will display the error code using the brush pressure LED's. If the operator presses a button assigned to a group that has not sensed an error, the controller will display no error code on the brush pressure LED's.

The error code assignments are as follows:

**ACTUATOR GROUP,  
SQUEEGEE BUTTON PRESSED**

PRESSURE 1	PRESSURE 2	PRESSURE 3	ERROR
-	-	On steady	No H-bridge, zero current
On steady	-	-	Early squeegee stall
-	On steady	-	No squeegee stall
Blinking		-	Early brush stall
-	Blinking	-	No brush stall
Blinking	Blinking	Blinking	Fuse is blown

**BRUSH MOTOR GROUP,  
SCRUB BUTTON PRESSED**

PRESSURE 1	PRESSURE 2	PRESSURE 3	ERROR
-	-	On steady	No brush motor zero current
On steady	-	-	Zero brush motor current
-	On steady	-	Low brush motor current
Blinking	Blinking	-	High brush motor current

**ACCESSORY OUTPUT GROUP  
SQUEEGEE AND SCRUB BUTTONS PRESSED**

SQUEEGEE LED	PRESSURE 1	PRESSURE 2	PRESSURE 3	ERROR
On steady	-	-	-	Hour meter output
-	On steady	-	-	Water valve output
-	-	On steady	-	Fan contactor output
-	-	-	On steady	Brush contactor output
-	Blinking	-	-	Backup alarm output

## NO BUTTONS PRESSED

SQUEEGEE LED (green)	ES™ LED (green)	OVERFLOW LED (red)	EMPTY SOLUTION LED (red)	ERROR
Blinking	-	-	-	Systems other than ES™ Self test passed
-	Blinking	-	-	ES™ self test passed
-	-	Blinking	-	Self test failed
-	-	-	Blinking	ES™ self test failed

## ES™ OUTPUT GROUP, ES™ BUTTON PRESSED

PRESSURE 1	PRESSURE 2	PRESSURE 3	ERROR
On steady	-	-	ES™ pump output

Operating Mode	Entry Sequence (how to activate)
<b>Manual Mode;</b> <i>Manually operate discrete functions without interlocks. In this mode, the battery LED #3 will blink.</i>	<ol style="list-style-type: none"><li>1. Place the machine in maintenance mode</li><li>2. Press and release the scrub button until pressure LED #2 is on.</li><li>3. Press and release the squeegee key</li><li>4. Battery LED#3 will begin to blink.</li></ol>

## MANUAL MODE

The purpose of the manual mode is to allow the operator to exercise individual functions on the machine. **This mode disregards the effects of various interlocks. Do not scrub with the machine in this mode.**

**FOR SAFETY: When Servicing Machine, Avoid Moving Parts. Do Not Wear Loose Jackets, Shirts, Or Sleeves.**

After entering the Manual Mode, the control buttons assume the following functions:

### SCRUB BUTTON

Pressing and releasing the scrub button in the normal way will toggle the scrub system on or off. If the scrub system is off and the user presses and holds the scrub button, the scrub head actuator will move downward.

**The head will continue down as long as the technician holds the scrub button. Care must be exercised by the technician not to hold the button too long. The actuator can stall when fully extended. Damage to the controller board and the actuator can result from continuing to provide power to a stalled actuator.**

Releasing the scrub button will cause the head to stop where it is. With the scrub system on, pressing and holding the scrub button will NOT send the scrub head downward but will turn the brush motor off. The motor will turn on again when the button is released. The head will stay down with the brushes running regardless of the direction signal from the propel pedal. The head will automatically raise when the user turns off the scrub system by pressing and releasing the scrub button in the normal way. Once the scrub system is turned off, pressing and holding the scrub button will again move the head actuator downward as described above.

**SQUEEGEE BUTTON**

Pressing the Squeegee button will toggle the vac fan on or off. It will also raise or lower the squeegee. In the manual mode, the squeegee and vac fan will remain active regardless of the state of the propel pedal reverse switch.

**ES™ BUTTON (Tennant machines only)**

Pressing the ES™ button will toggle the ES™ pump on or off. In the on position, the ES™ pump will run regardless of the state of the floats. Care should be taken not to run the ES™ pump dry for more than a few seconds.

## INTERLOCKS

The operator can start and stop the various functions of the 7100 scrubber using a variety of closures and interlocks. What follows are two tables for each of the three basic scrubbing functions (Scrub brushes, Squeegee/vacuum fan, and ES™ pump). One table lists the actions required for the basic function to be running. The other table lists the actions that would prevent the operation from running. If the operator satisfies all of the requirements from the first table, and none of the situations of the second table exist, the operator could expect the function to operate.

## SCRUB BRUSH OPERATION

<i>SCRUB BRUSH OPERATION ENABLED BY:</i>	<i>INDICATOR</i>
● Scrub button	● One or more scrub pressure LED's on
● Forward or reverse propel	● Forward or reverse engaged

<i>SCRUB BRUSH OPERATION INHIBITED BY:</i>	<i>INDICATOR</i>
● Scrub button	● All scrub pressure LED's off
● Neutral	● Forward and reverse disengaged
● Low battery	● Battery 1 LED blinking
● Open brush motor circuit breaker	● All three scrub pressure LED's blinking
● Full recovery tank	● "Recovery tank full" LED blinking

## SQUEEGEE AND VACUUM FAN OPERATION

<i>SQUEEGEE FUNCTION ENABLED BY:</i>	<i>INDICATOR</i>
● Scrub button or squeegee button	● Squeegee LED on
● Forward or neutral	● Reverse disengaged

<i>SQUEEGEE FUNCTION INHIBITED BY:</i>	<i>INDICATOR</i>
● Scrub button or squeegee button	● Squeegee LED off
● Reverse	● Reverse engaged
● Low battery	● Battery 1 LED blinking
● Full recovery tank	● "Recovery tank full" LED blinking

**ES™ PUMP OPERATION**

<i>ES™ PUMP ENABLED BY:</i>	<i>INDICATOR</i>
<ul style="list-style-type: none"> <li>● ES™ button</li> </ul>	<ul style="list-style-type: none"> <li>● ES™ LED on</li> </ul>
<ul style="list-style-type: none"> <li>● ES™ float covered, or ES™ 30 second timer running. The ES™ 30 second timer starts when the ES™ pump brings the solution level below the ES™ float.</li> </ul>	

<i>ES™ PUMP INHIBITED BY:</i>	<i>INDICATOR</i>
<ul style="list-style-type: none"> <li>● ES™ button</li> </ul>	<ul style="list-style-type: none"> <li>● ES™ LED off</li> </ul>
<ul style="list-style-type: none"> <li>● More than 30 seconds has passed since the ES™ float has become uncovered</li> </ul>	
<ul style="list-style-type: none"> <li>● Solution tank full float covered for more than 5 seconds</li> </ul>	

<b>Operating Mode</b>	<b>Entry Sequence (how to activate)</b>
<b>Input Display Mode;</b> <i>Display the state of floats, limit switches, and sensors. In this mode, battery LED #1 will blink.</i>	1. Place the machine in maintenance mode 2. Press and release the scrub button until both scrub pressure LED's #2 & #3 are on. 3. Press and release the squeegee key

### **INPUT DISPLAY MODE**

The purpose of the Input Display Mode is for the technician to observe the effectiveness of various inputs and sensors on the controller board. When in this mode, the operator can scrub with the machine as normal and observe the operation of the various inputs.

When in the Input Display Mode, each of the control panel LED's are associated with one board input. When the operator activates an input, the corresponding LED will become illuminated.

The operator may activate scrub functions in this mode. The LED's on the instrument panel no longer correspond to the control status while in the Input Display Mode. For instance, in the normal mode, if the squeegee LED is on, this means that the squeegee and vacuum fan are active. In the Input Display Mode, this LED indicates that the solution tank full float is active. The buttons however, retain their normal functions. Pressing the squeegee button will turn on the squeegee, even though the LED may not turn on. The controller will temporarily display scrub pressure when the operator presses and holds the scrub button. If the operator holds the scrub button long enough, the machine will scroll slowly through the down pressures.

The assignments of LED's to inputs are as follows:

- Battery 1.– When battery 1 LED is blinking, the controller is in the input display mode.
- Battery 2.–When the battery 2 LED is on, the controller senses forward. (P4–6 high)
- Battery 3.–When the battery 3 LED is on, the controller senses neutral. (P4–12 low)
- Battery 4.–When the battery 4 LED is on, there is power sensed on the outputs of both brush motor circuit breakers. (P4–10 high)



Squeegee – When the squeegee LED is on, the solution tank full float is active.

(P4–9 low)

Overflow – When the overflow LED is on, the recovery tank full float is active.

(P4–3 low)

ES™ – When the ES™ LED is on, the ES™ float is active. (P4–2 low)

Solution – When the solution empty LED is on, the solution tank empty float is active. (P4–8 high) (Tennant only)

Pressure 1.–When the pressure 1 LED is on, the scrub is active, and the brush current detected is below the minimum level for the selected pressure setting.

Pressure 2.–When the pressure 2 LED is on, the scrub mode is active.

Pressure 3.–When the pressure 3 is on, the scrub mode is active, and the brush current detected is above the maximum level for the selected pressure setting.

Operating Mode	Entry Sequence (how to activate)
<b>Restricted Down Pressure Mode;</b> <i>Toggles the machine between a normal and a restricted down pressure setting.</i>	<ol style="list-style-type: none"><li>1. Place the machine in maintenance mode</li><li>2. Press and release the scrub button until scrub pressure LED #1</li><li>3. Press and release the squeegee key</li></ol>

## RESTRICTED DOWN PRESSURE MODE

This mode is used to restrict the machine to the two lower down pressures. Each time the machine enters this mode, the machine will toggle in and out of the reduced down pressure mode.

1. While holding the squeegee button, turn the key to the start position and then release it.
2. Keep holding the squeegee button until scrub pressure LED#3 is lit and then release it.
3. Press and release the scrub button until scrub pressure LED#1 is on.
4. Press and release the squeegee key.

Operating Mode	Entry Sequence (how to activate)
<b>Software Date Display Mode;</b> <i>Flashes the current software date code via the touchpanel LED's</i>	<ol style="list-style-type: none"> <li>1. Place the machine in maintenance mode</li> <li>2. Press and release the scrub button until both scrub pressure LED's #1 &amp; #3 are on.</li> <li>3. Press and release the squeegee key</li> </ol>

### SOFTWARE DATE DISPLAY MODE

In this mode, the date of the current software will be flashed on the touch panel.

1. While holding the squeegee button, turn the key to the start position and then release it.
2. Keep holding the squeegee button until scrub pressure LED#3 is lit and then release it.
3. Press and release the scrub button until scrub pressure LED#1 and #3 are on.
4. Press and release the squeegee key.

The date of the current software will be flashed on the touch panel as follows:

1. The number of times the center pressure LED flashes is the month of the software change date. *(i.e. – if it flashes 7 times, the month is July)*
2. The number of times the squeegee LED flashes is the day of the month of the software changes. *(i.e. – if it flashes 20 times, the day of the month is the 20th)*
3. The number of times the overflow LED flashes is the year of the software change date. *(i.e. – if it flashes 0 times, the year is 2000 and if it flashes 1 time, the year is 2001)*
4. This sequence of 2 or 3 LEDs will continue flashing until the key switch is turned off.

# ELECTRICAL

## CIRCUIT BOARD PIN FUNCTIONS

PIN #'S	FUNCTION	ACTIVE VOLTAGE	INACTIVE VOLTAGE
P4-10	INPUT	B-, CB7 OR CB8 RESET (OPEN)	B+, CB7 AND CB8 SET (CLOSED)
P4-11	INPUT	B+	B-, BATTERY DISCONNECTED, RESET BATTERY GAUGE
P3-2, P3-7, P4-1	POWER	B+	B-
P3-12, P3-11, P3-13, P3-14, P3-9	OUTPUTS	B-	B+
P3-10, P3-15, P3-4, P3-5	BI-DIRECTIONAL H-BRIDGE OUTPUTS	REVERSIBLE, 0-36V	B+
P4-3, P4-2, P4-9, P4-8	INPUTS	B-	+2 to +5V
P4-7, P4-12,	INPUTS	B-	B+
P4-6	INPUTS	B+	B-
P5-3, P5-2	SHUNT INPUTS	1.44mv/A	B-
P3-3, P5-1, P3-8, P4-5	GROUND	B-	

### SCRUB BRUSH MOTOR CURRENT DRAW SPECIFICATIONS:

Brush motor current draw at #3 down pressure:  
16 – 19 amps per motor

### CURTIS® PROPEL CONTROL LED OPERATION

During normal operation, with no faults present, the Status LED is steadily on. If the controller detects a fault, the status LED flashes a 2-digit fault identification code continuously until the fault is corrected (see table below).

## CURTIS® PROPEL CONTROLLER TROUBLESHOOTING

LED CODE	PROGRAMMER LCD DISPLAY	EXPLANATION	POSSIBLE CAUSE
1,1	Hardware Failsafe 2	output fault	1. Short in motor or in motor wiring. 2. Controller failure.
	Hardware Failsafe 4	overcurrent fault	1. Short in motor or in motor wiring. 2. Controller failure.
1,2	Hardware Failsafe 1	EEPROM fault	1. EEPROM failure or fault.
	Hardware Failsafe 3	main contactor fault	1. Main contactor welded. 2. Main contactor driver fault. 3. Main contactor coil fault.
	Precharge fault	precharge fault	1. Internal controller fault. 2. Low battery voltage.
	HW Failsafe	motor voltage fault	1. Motor voltage does not correspond to throttle request. 2. M1 or M2 output shorted to B- or B+. 3. Internal motor short. 4. Controller failure.
2,1	SRO	SRO fault	1. Improper sequence of KSI, power enable, and direction inputs. 2. Wrong SRO type selected. 3. Direction switch circuit open.
2,2	HPD	HPD fault	1. Improper sequence of KSI, power enable, and throttle inputs. 2. Misadjusted throttle pot.
2,3	Proc/Wiring fault	HPD fault present for > 5 sec	1. Misadjusted throttle. 2. Broken throttle pot. 3. Broken throttle mechanism.
2,4	SPD Limit Pot fault	speed limit pot fault	1. Speed limit pot wiper wire broken. 2. Broken speed limit pot.
3,1	BB Wiring Check	emerg. reverse wiring fault	1. BB wire open. 2. BB check wire open.
3,2	EM Brake Drvr fault	electromag. brake driver fault	1. Electromagnetic brake coil shorted or open. 2. Electromagnetic brake wiring open.
3,3	Throttle Fault 1	throttle fault	1. Throttle input wire open. 2. Throttle input wire shorted to B- or B+. 3. Throttle pot defective. 4. Wrong throttle type selected.
4,1	Low Battery Voltage	low battery voltage	1. Battery voltage <16 volts (24V models), <21V (36V models), or <27V (48V models). 2. Corroded or loose battery terminal. 3. Loose controller terminal.
4,2	Overvoltage	overvoltage	1. Battery voltage >36 volts (24V models), >48V (36V models), or >60V (48V models). 2. Vehicle operating with charger attached.
4,3	Thermal Cutback	over-/under-temp. cutback	1. Temperature > 95°C or < -25°C 2. Excessive load on vehicle. 3. Improper mounting of controller. 4. Operation in extreme environments.

## TROUBLESHOOTING

---

The following troubleshooting section should be used to diagnose and repair the electrical system on the model 7100.

ES™ SYSTEM

OPERATION:

WITH RECOVERY TANK SWITCH 1/2 FULL = S6 CLOSED AND SOLUTION TANK SWITCH NOT FULL = S2 OPEN THE ES SYSTEM IS SELECTED ON THE TOUCH PANEL, THE ES LED TURNS ON AND CIRCUIT 31/PNK (P3-14) IS SWITCHED TO GND THRU THE CONTROL BOARD, TURNING ON THE ES™ PUMP

NOTE: ONCE THE ES PUMP IS TURNED ON, IT WILL KEEP RUNNING UNTIL SWITCH S6 OPENS FOR 30 SECONDS (= RECOVERY TANK LESS THAN 1/2 FULL)  
OR  
SWITCH S2 CLOSES (= SOLUTION FULL)

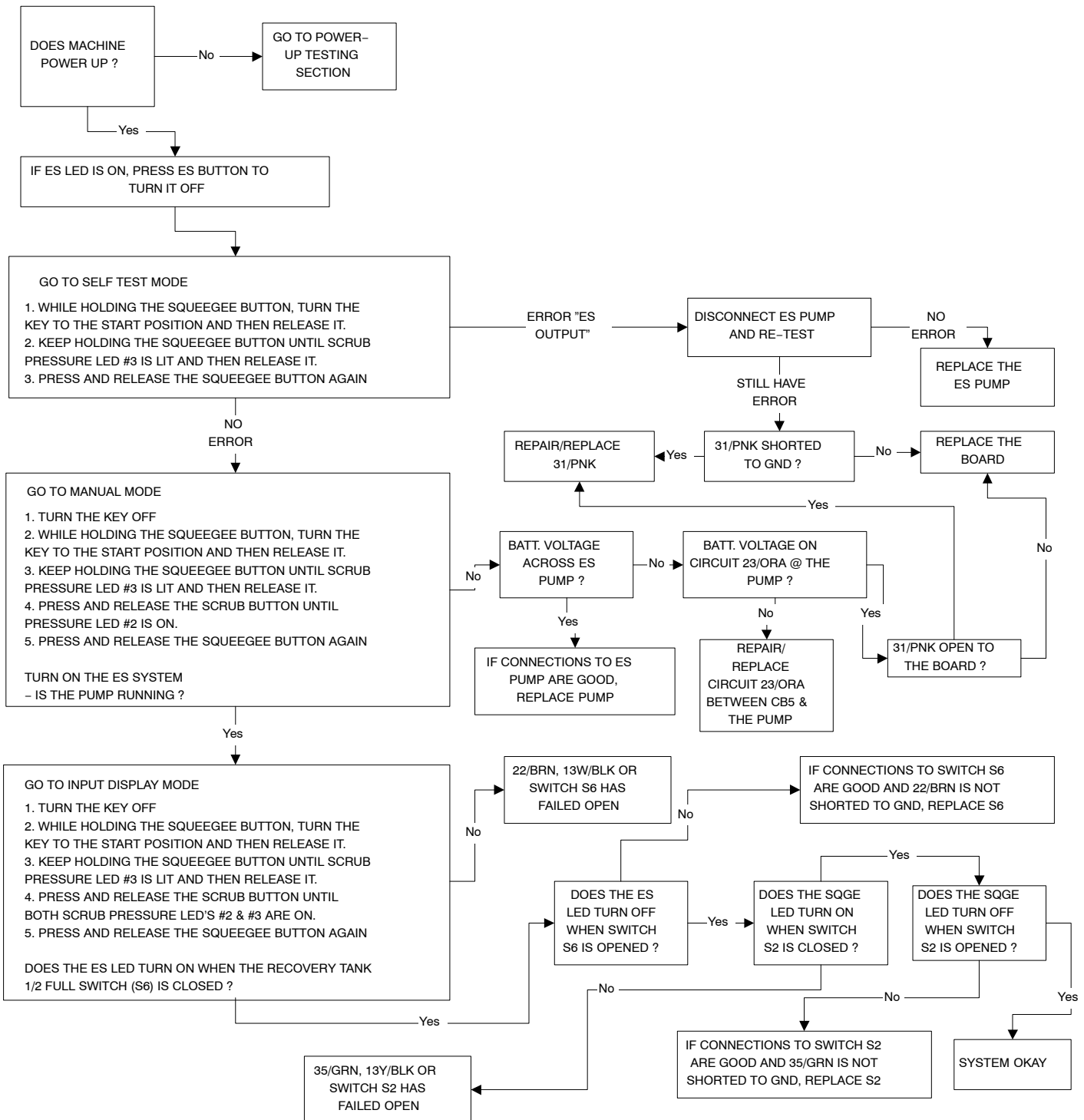

ES™ SYSTEM

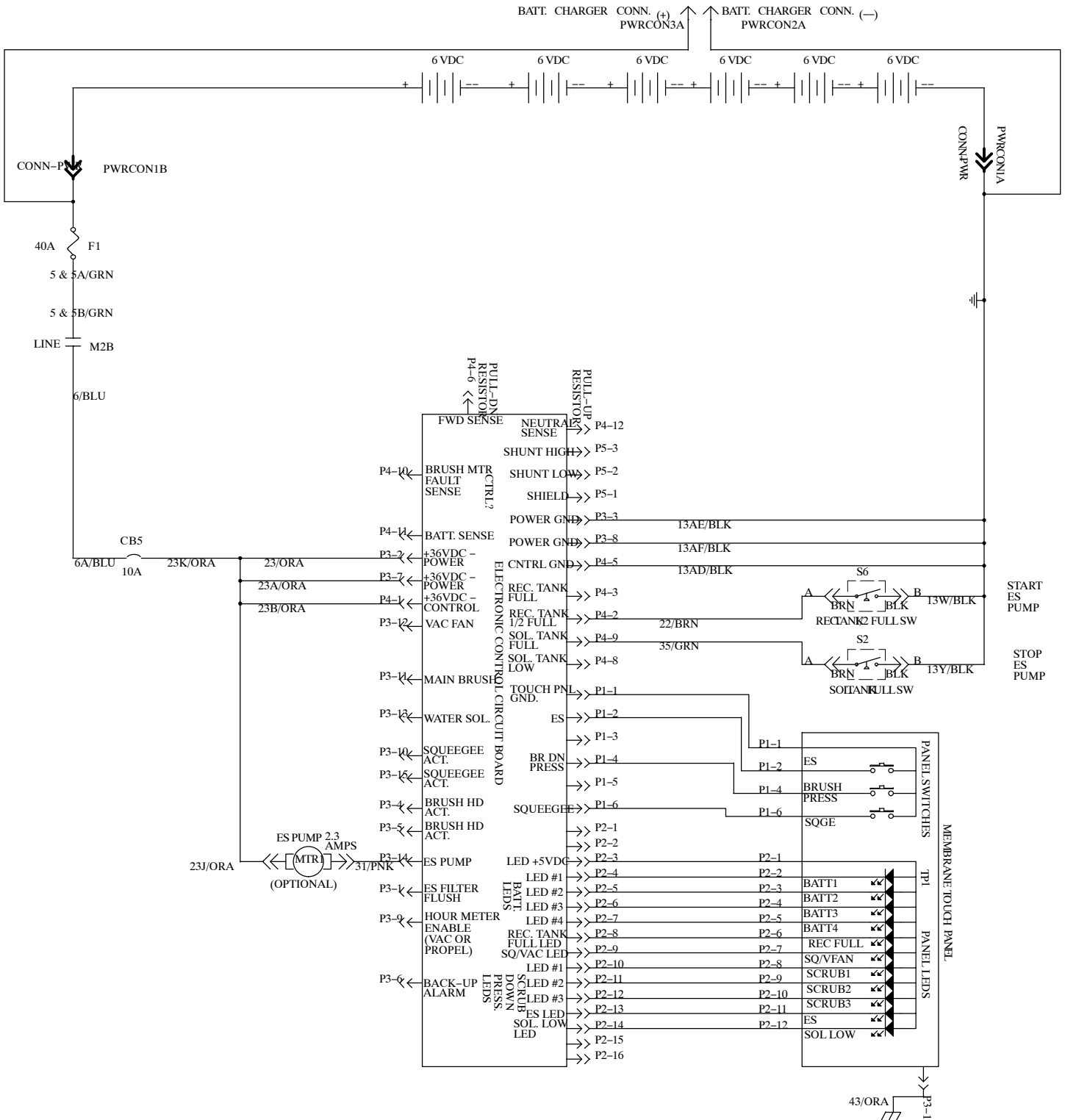



## HORN

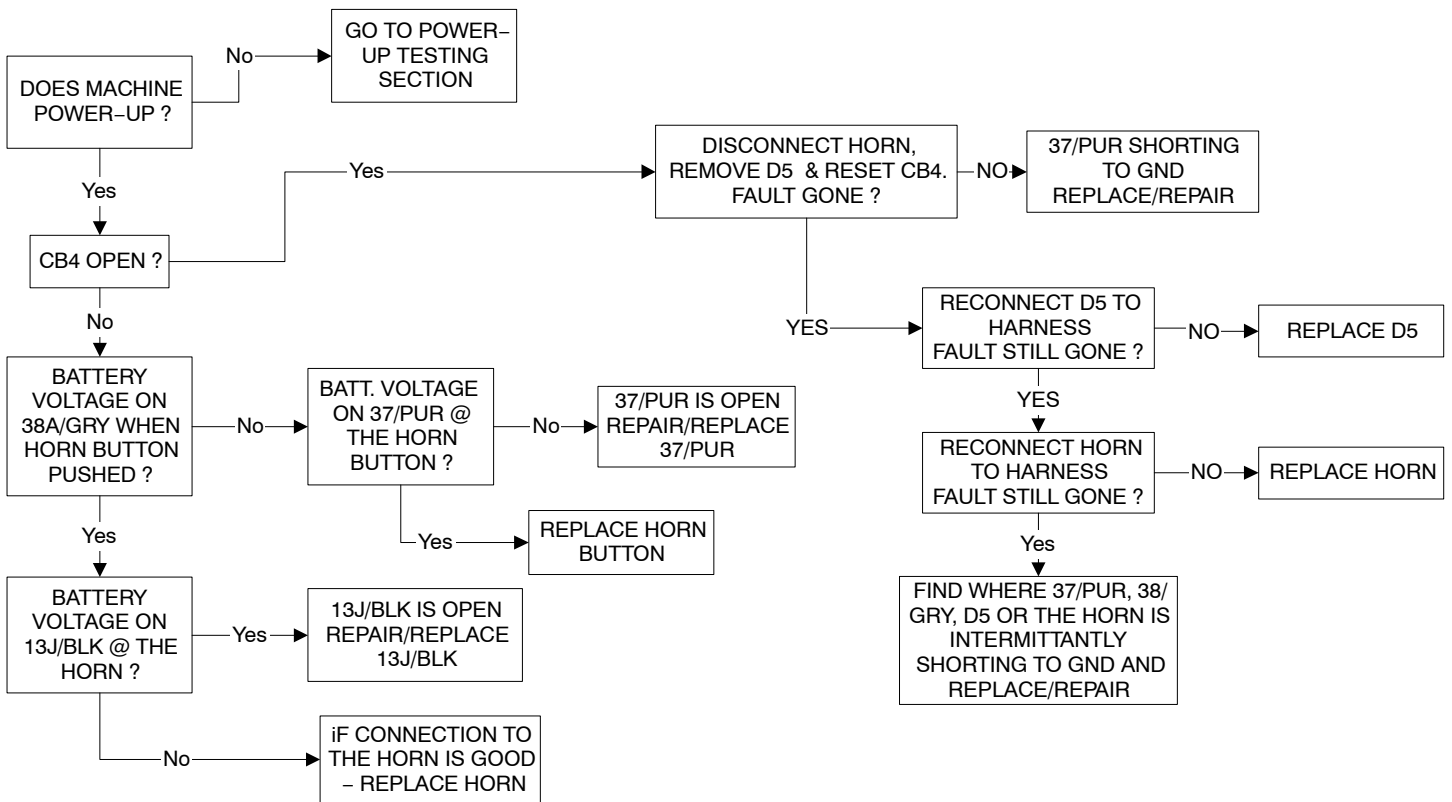



## SHROUD LIGHT/HEAD LIGHTS

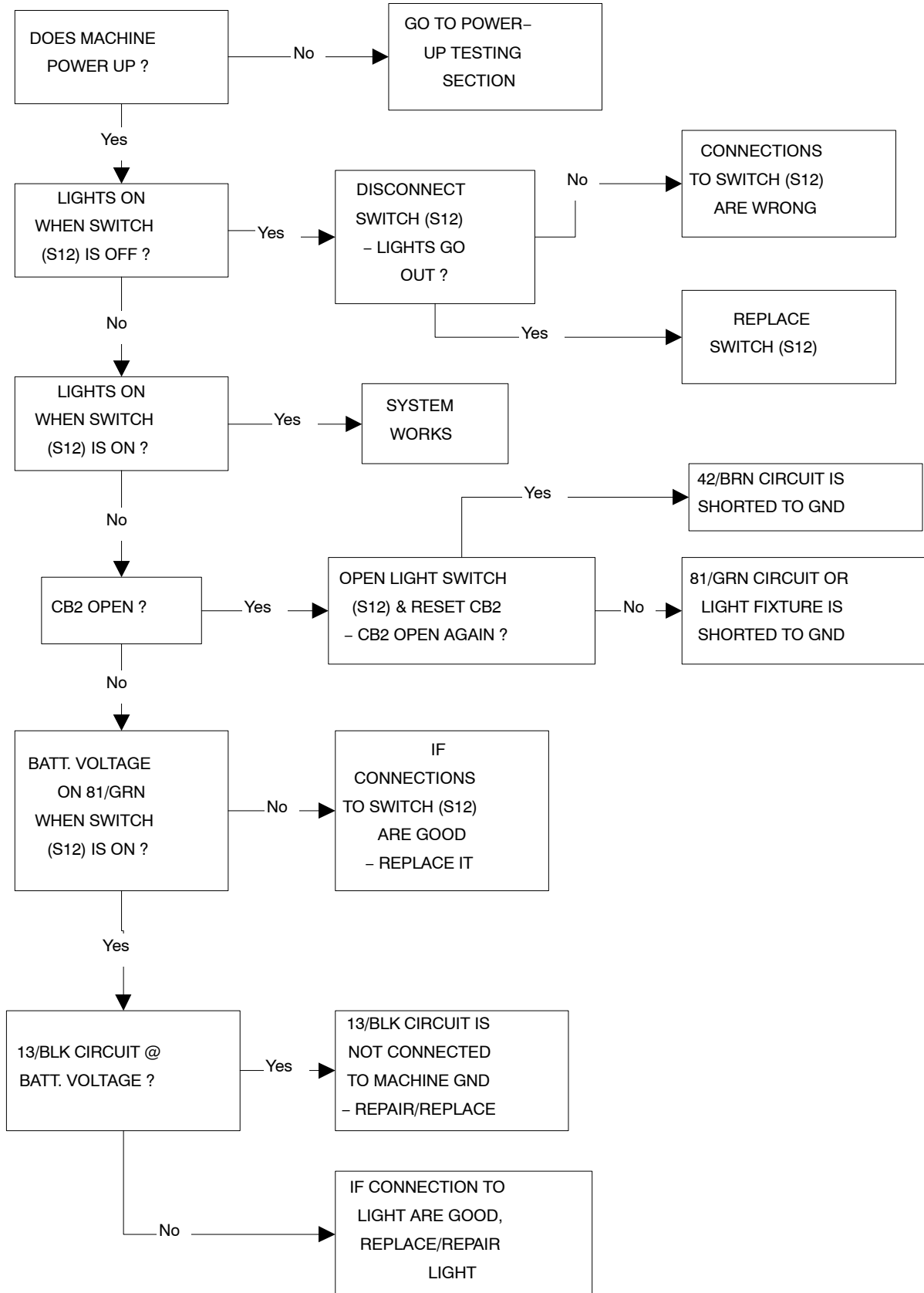

**SHROUD LIGHT/HEAD LIGHTS**

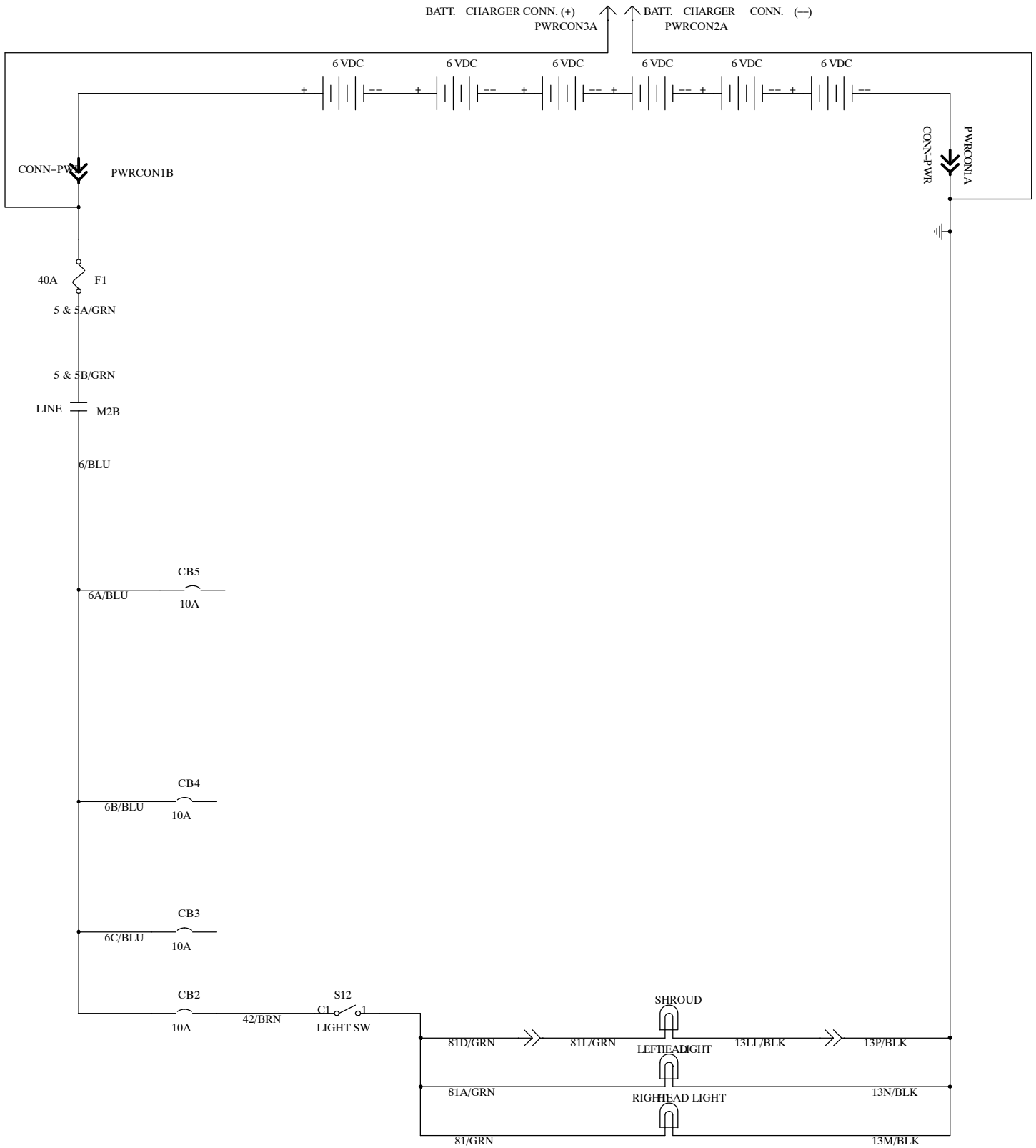

## PROPEL CONTROLLER

OPERATION: (VIEWING THE CONNECTIONS ON THE PROPEL CONTROLLER)

1. WITH THROTTLE POTENTIOMETER IN THE NEUTRAL POSITION (2.5V @ P1-2), M1 & M2 ARE BOTH HELD @ B+ VOLTAGE AND THE PROPEL MOTOR DOES NOT MOVE.
2. WITH THROTTLE POTENTIOMETER IN THE FORWARD POSITION (2.5V TO 5.0V @ P1-2), M1 IS HELD @ B+ VOLTAGE AND M2 IS PULSED TO GND. THE VOLTAGE APPLIED TO THE MOTOR IS PROPORTIONAL TO HOW HIGH THE THROTTLE VOLTAGE GOES ABOVE 2.5VDC.
3. WITH THROTTLE POTENTIOMETER IN THE REVERSE POSITION (2.5V TO 0V @ P1-2), M2 IS HELD @ B+ VOLTAGE AND M1 IS PULSED TO GND. THE VOLTAGE APPLIED TO THE MOTOR IS PROPORTIONAL TO HOW LOW THE THROTTLE VOLTAGE GOES BELOW 2.5VDC.

NOTE: AT POWER-UP, THE PROPEL CONTROLLER MUST SEE A NEUTRAL SIGNAL (2.5V @ P1-2) AND THE SEAT SWITCH MUST BE OPEN (4.5V-5.0V @ 15/GRN) OR IT WILL NOT PROPEL FORWARD OR REVERSE

**CAUTION:** MACHINE COULD RUN AWAY IF YOU DON'T LIFT THE PROPEL WHEEL OFF THE FLOOR BEFORE PROCEEDING

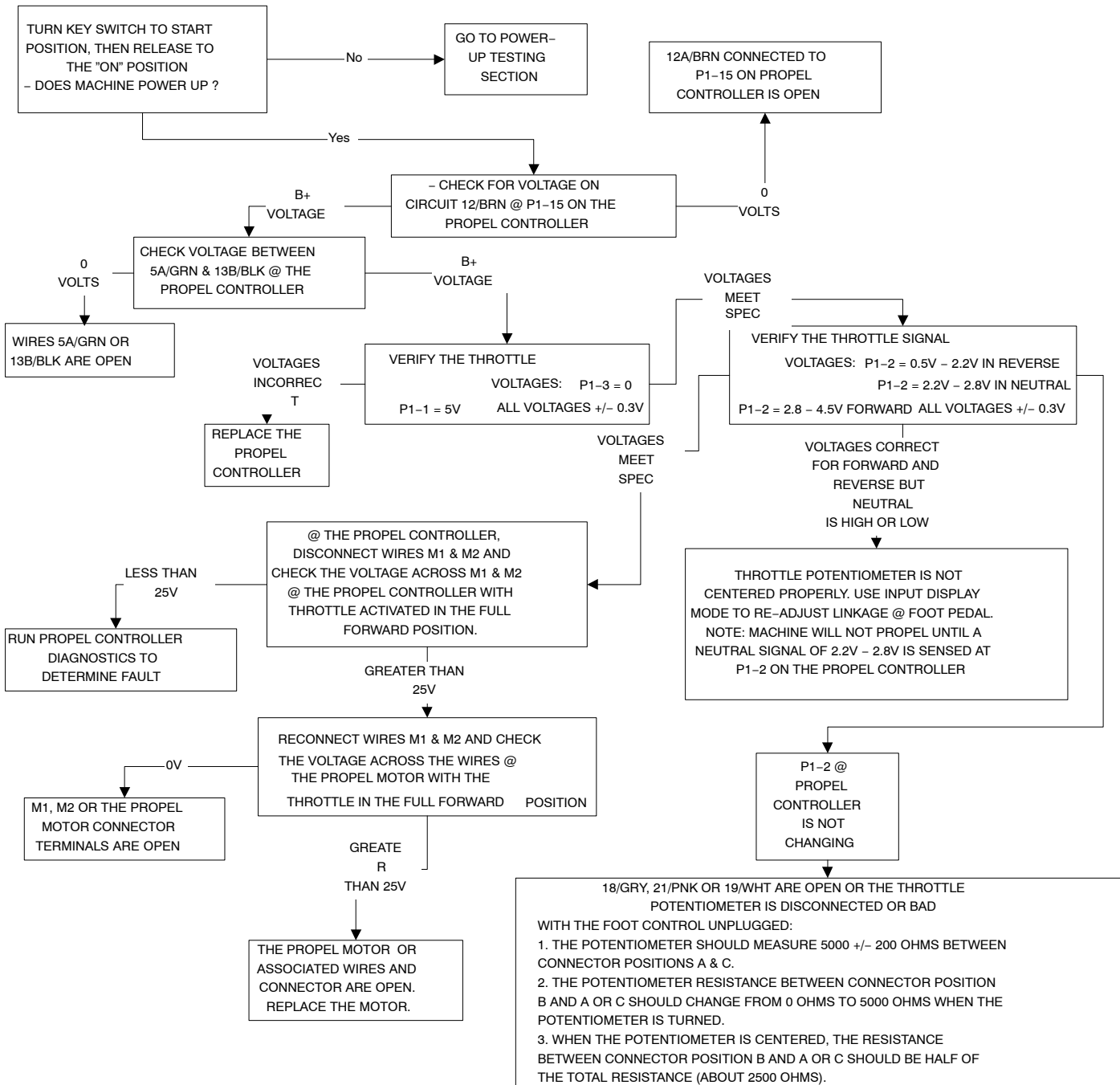

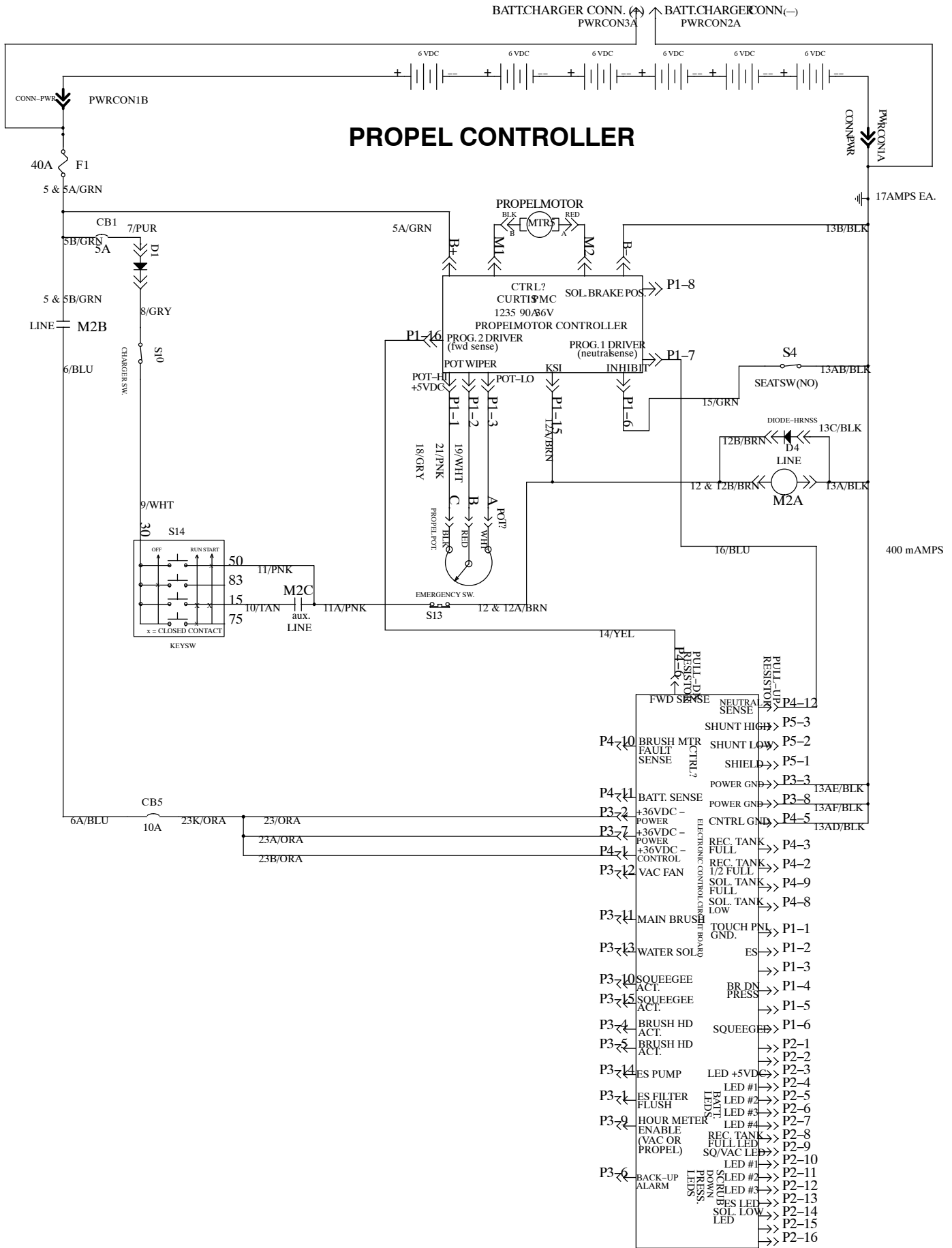

**POWER WAND & BACKUP ALARM**

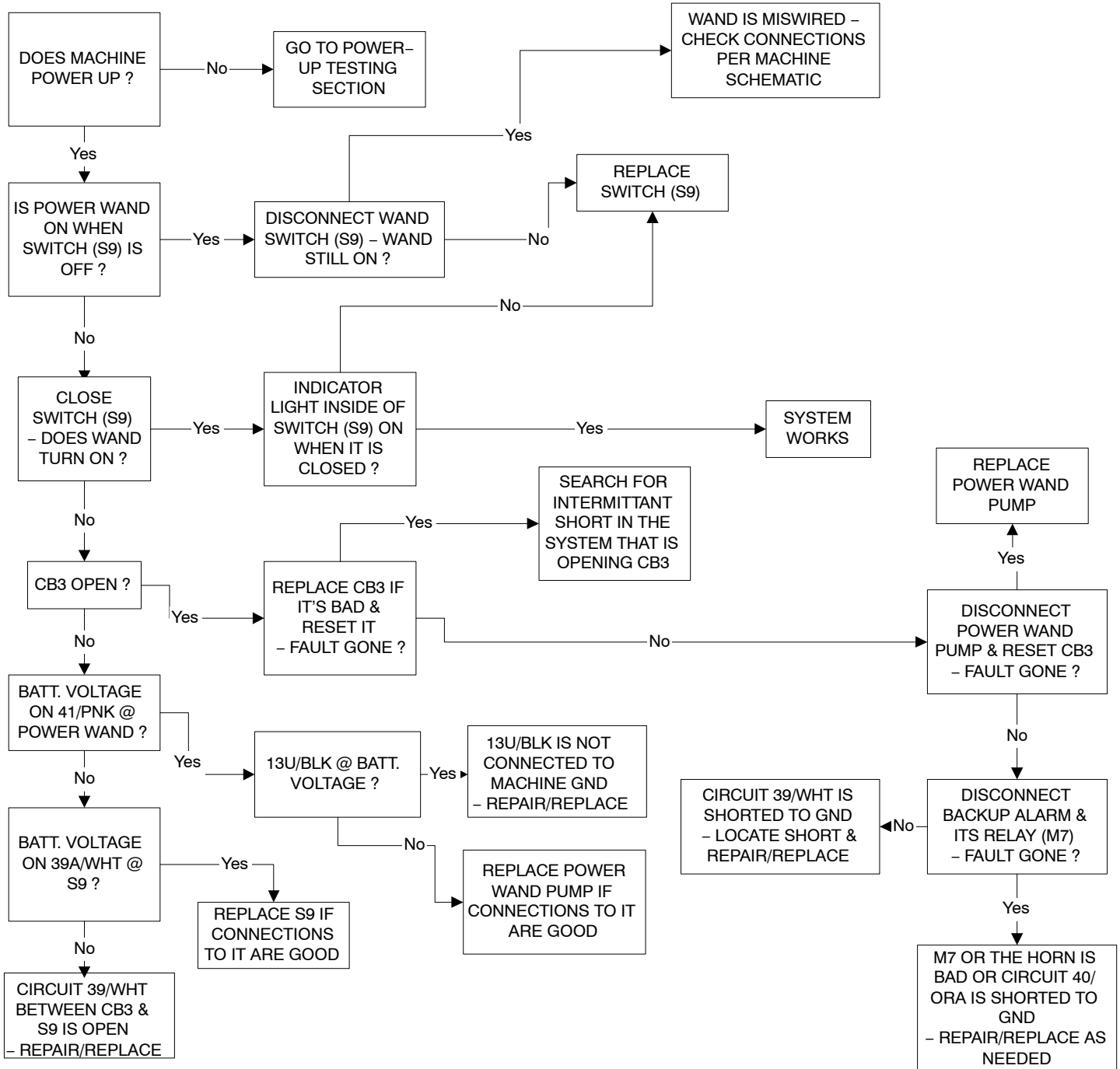

**POWER WAND & BACKUP ALARM**

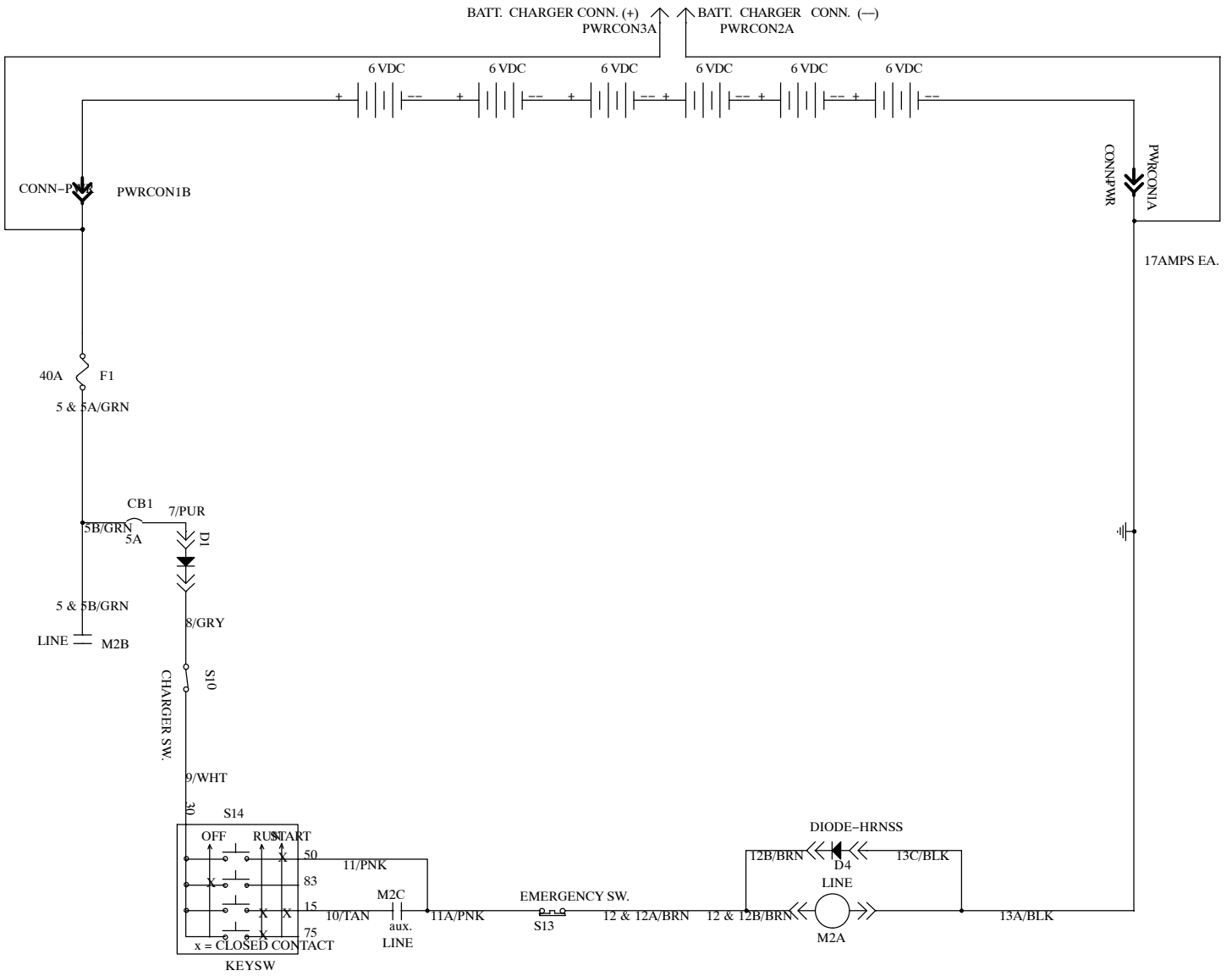



## POWER-UP TESTING

## OPERATION:

- ASSUMING THAT THE EMERGENCY & THE CHARGER SWITCHES ARE BOTH CLOSED, THE KEY SWITCH IS TURNED TO 'START' POSITION, POWER FLOWS THRU THE CHARGER SWITCH, INTO KEYSWITCH TERMINAL 30, OUT OF TERMINAL 50, THRU THE EMERGENCY SWITCH, TURNING ON M2 CONTACTOR AND POWERING UP THE MACHINE.

- KEY IS RELEASED TO THE 'RUN' POSITION, POWER NOW FLOWS THRU THE CHARGER SWITCH, INTO KEY SWITCH TERMINAL 30, OUT OF TERMINAL 15, THRU M2 AUX. CONTACTS & THE EMERGENCY SWITCH, THUS HOLDING M1 CONTACTOR ON AND KEEPING THE MACHINE POWERED UP.

- KEY SWITCH IS TURNED TO THE OFF POSITION OR THE EMERGENCY OR CHARGER SWITCH OPENS, POWER THRU THE M2 COIL IS CUT OFF, M2 CONTACTS OPEN AND THE MACHINE TURNS OFF.

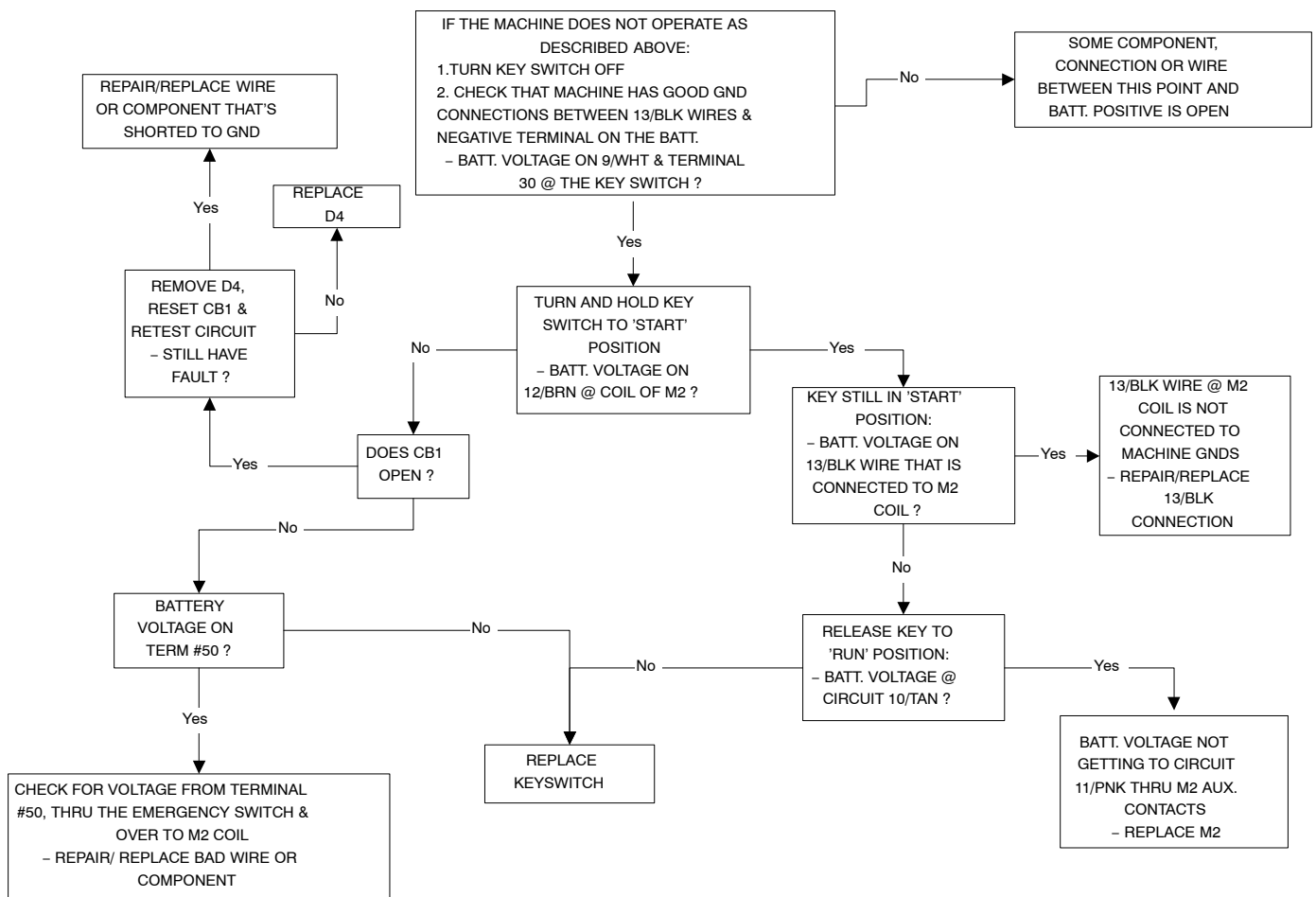

**POWER-UP TESTING**

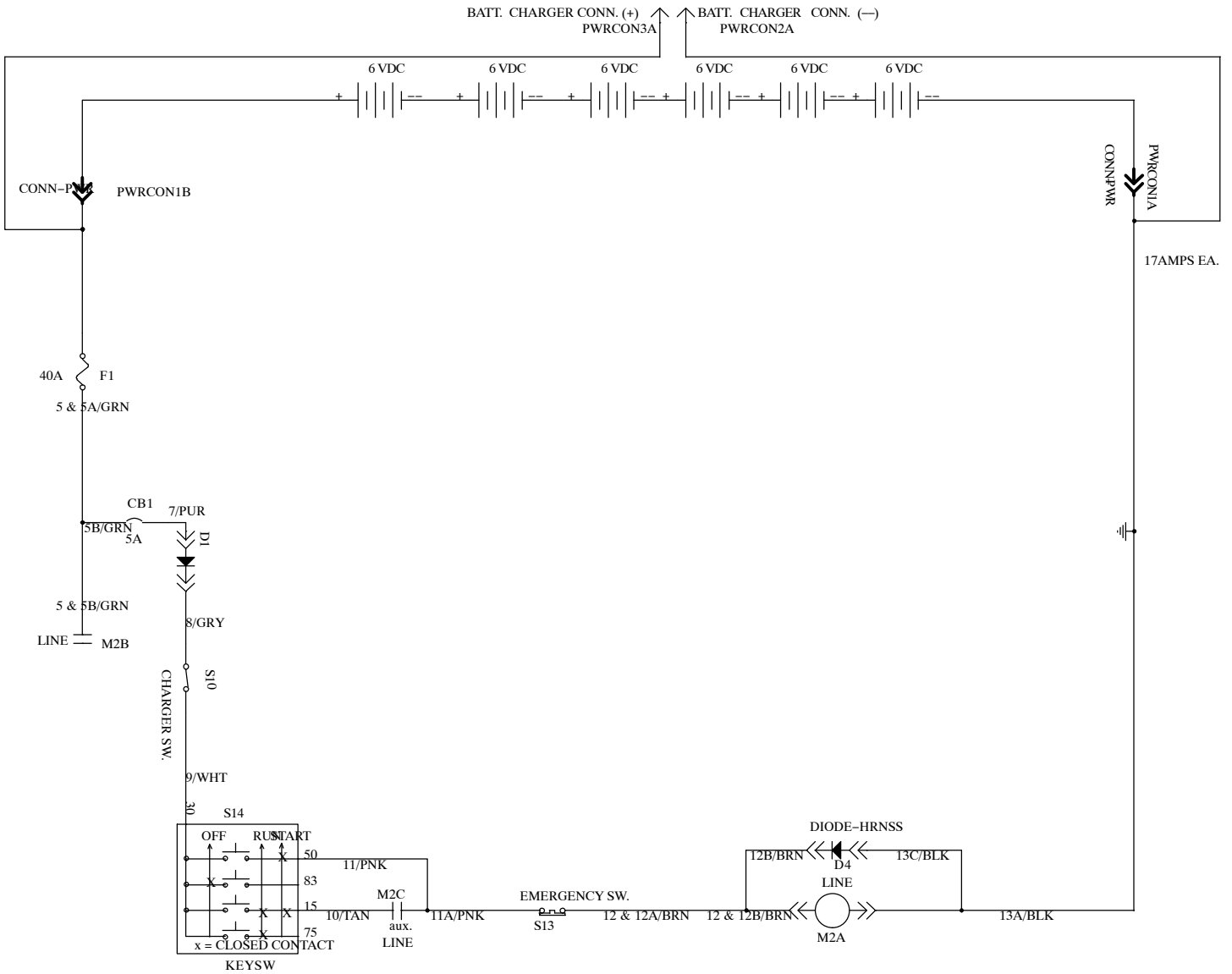

# SCRUB SYSTEM

**OPERATION: WHEN THE SCRUB BUTTON IS PUSHED, THE MACHINE ACTIVATES THE ONE TOUCH SCRUB SYSTEM:**

- THE SQUEEGEE LOWERS
- THE VAC FAN TURNS ON
- THE SCRUB HEAD COMES DOWN
- THE ES SYSTEM TURNS ON IF IT PREVIOUSLY WAS ON.

**WHEN NOT IN NEUTRAL:**

- THE BRUSHES TURNS ON
- THE SOLUTION VALVE TURNS ON AND IS REGULATED BY THE FLOW CONTROL LEVER ON THE CONTROL PANEL WHILE THE WHILE THE SCRUB ACTUATOR LOWERS OR LIFTS:
- TO LOWER, 29/WHT (P3-4) RECEIVES POSITIVE VOLTAGE WHILE 30/TAN (P3-5) IS PULSED LOW
- TO LIFT, 30/TAN (P3-5) RECEIVES POSITIVE VOLTAGE WHILE 29/WHT (P3-4) IS PULSED LOW

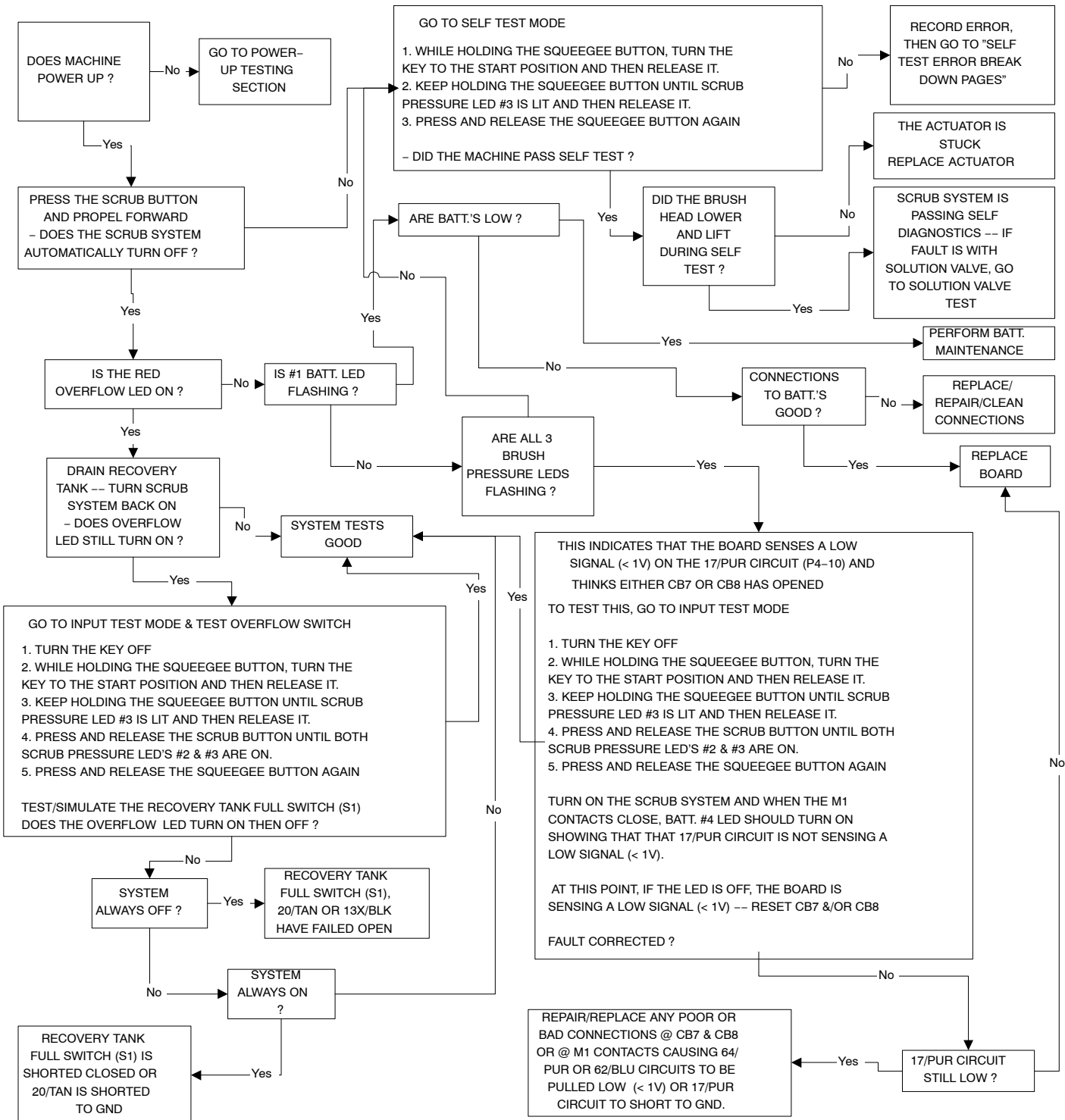

**SCRUB SYSTEM****SELF TEST ERROR  
BREAKDOWN**

IF ERROR READS = "BRUSH CONTACTOR OUTPUT"  
(BOTH SQUEEGEE AND BRUSH BUTTONS HELD, DOWN PRESSURE LED #3 LIT)  
- DISCONNECT 25/GRN AT M1 AND RERUN SELF TEST  
- NO ERROR NOW = REPLACE M1  
- SAME ERROR STILL: DISCONNECT CONTROL BOARD, IF 25/GRN IS NOT SHORTED TO GND, REPLACE CONTROL BOARD

IF ERROR READS = "NO H-BRIDGE ZERO CURRENT"  
(SQUEEGEE BUTTON HELD, DOWN PRESSURE LED #3 LIT)  
- REPLACE CONTROL BOARD

IF ERROR READS = "EARLY BRUSH STALL"  
(SQUEEGEE BUTTON HELD, DOWN PRESSURE BLINKING LED #1 LIT)  
- DISCONNECT BRUSH HEAD ACTUATOR AND RE-RUN SELF TEST  
- SAME ERROR: 29/WHT & 30/TAN ARE SHORTED OR CONTROL BOARD IS BAD  
- NOW GET "NO BRUSH STALL" ERROR: REPLACE BRUSH HEAD ACTUATOR

IF ERROR READS = "NO BRUSH STALL"  
(SQUEEGEE BUTTON HELD, DOWN PRESSURE BLINKING LED #2 LIT)  
- 30/TAN, 29/WHT OR THE BRUSH HEAD ACTUATOR IS OPEN

IF ERROR READS = "NO BRUSH MOTOR ZERO CURRENT"  
(SCRUB BUTTON HELD, DOWN PRESSURE LED #3 LIT)  
- IF THE BRUSHES ARE ALWAYS ON WHEN THE KEY SWITCH IS ON: REPLACE M1 CONTACTOR  
- IF THE BRUSHES TURN ON AND OFF DURING SELF TEST: REPLACE THE CONTROL BOARD

IF ERROR READS = "ZERO BRUSH MOTOR CURRENT"  
(SCRUB BUTTON HELD, DOWN PRESSURE LED #1 LIT)  
- WHEN THE BRUSHES MOMENTARILY TURNED ON DURING THE SELF TEST, THE BRUSH MOTOR SHUNT SIGNAL DID NOT GET TO THE CONTROL BOARD.  
- CHECK THE SHUNT & ITS CONNECTIONS AND THE CONNECTIONS FOR WIRES 88/BLK, 87/CLR & 13AG/SHLD @ CONTROL BOARD

IF ERROR READS = "LOW BRUSH MOTOR CURRENT"  
(SCRUB BUTTON HELD, DOWN PRESSURE LED #2 LIT)  
- GO TO MANUAL MODE, TURN ON SCRUB BRUSHES -- VERIFY THAT BOTH BRUSHES ARE TURNING  
- IF ONLY ONE MOTOR IS OPERATING: REPAIR/REPLACE THE OPEN WIRE OR MOTOR THAT IS CAUSING THE PROBLEM  
- IF BOTH BRUSHES ARE TURNING -- IGNORE THIS ERROR -- SYSTEM TESTS GOOD  
- NOTE: CHECK FOR BROKEN BELTS ON CYLINDRICAL HEAD

IF ERROR READS = "HIGH BRUSH MOTOR CURRENT"  
- GO TO MANUAL MODE, TURN ON SCRUB BRUSHES  
- MEASURE BRUSH CURRENT WITH AMP PROBE  
- REPLACE MOTOR(S) WITH EXCESSIVE AMP DRAW

- IF NONE OF THESE ERRORS ARE FOUND: THE SCRUB SYSTEM IS PASSING SELFTEST DIAGNOSTICS  
- DETERMINE WHAT OTHER ERROR IS CAUSING THE SELFTEST FAILURE AND TROUBLESHOOT THAT SECTION

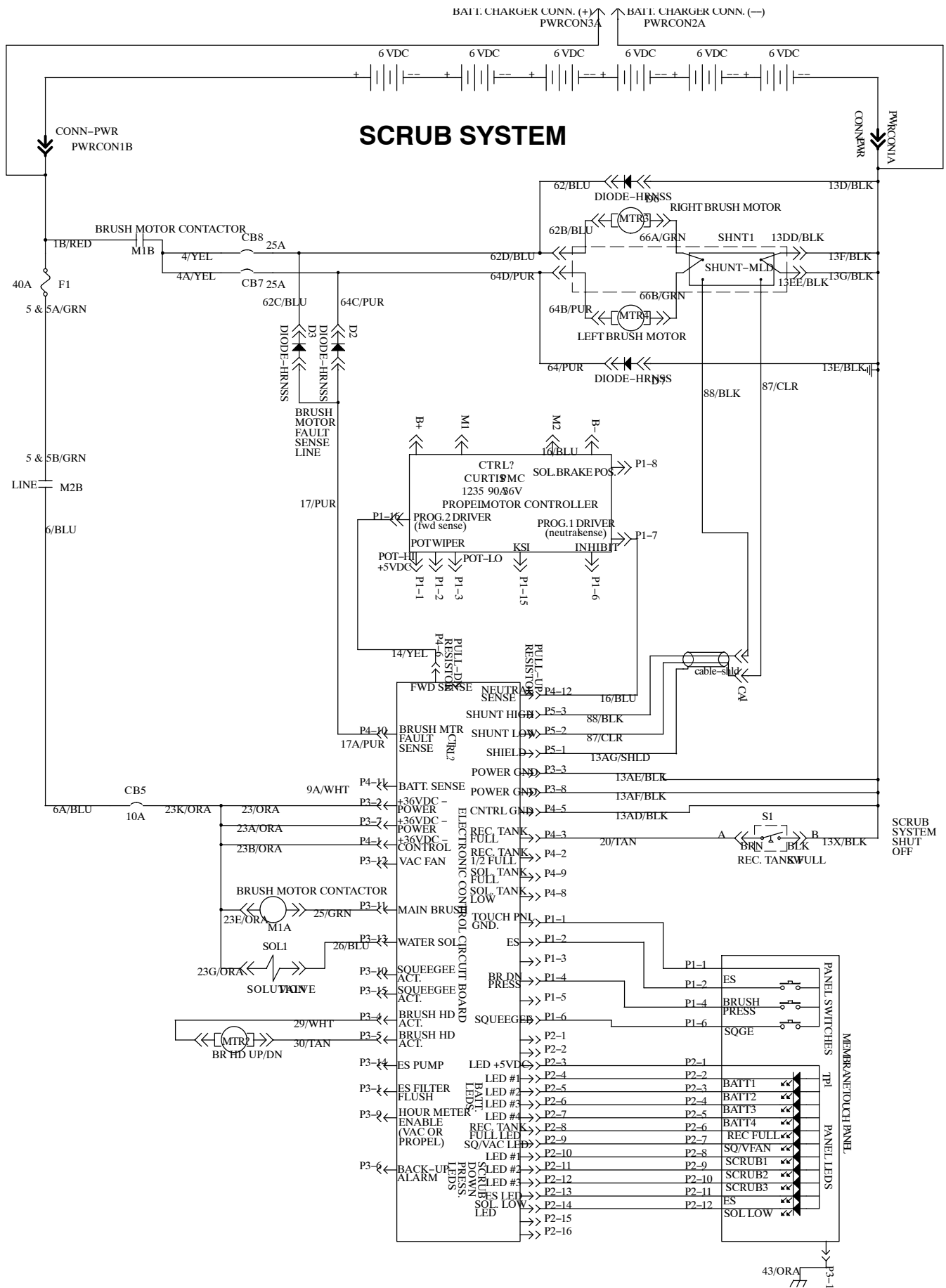



## SOLUTION EMPTY

### OPERATION:

WHEN THE MACHINE IS POWERED UP AND THE SOLUTION EMPTY SWITCH (S3) IS OPEN, DISCONNECTING 36/BLU FROM GND FOR 10 - 15 SEC.'S, THE SOLUTION EMPTY LIGHT TURNS ON AND STAYS ON UNTIL SWITCH (S3) OPENS AGAIN AND EITHER:

- POWER TO THE BOARD IS TURNED OFF AND THEN BACK ON AGAIN
- OR
- THE SCRUB FUNCTION IS TURNED OFF AND THEN BACK ON AGAIN

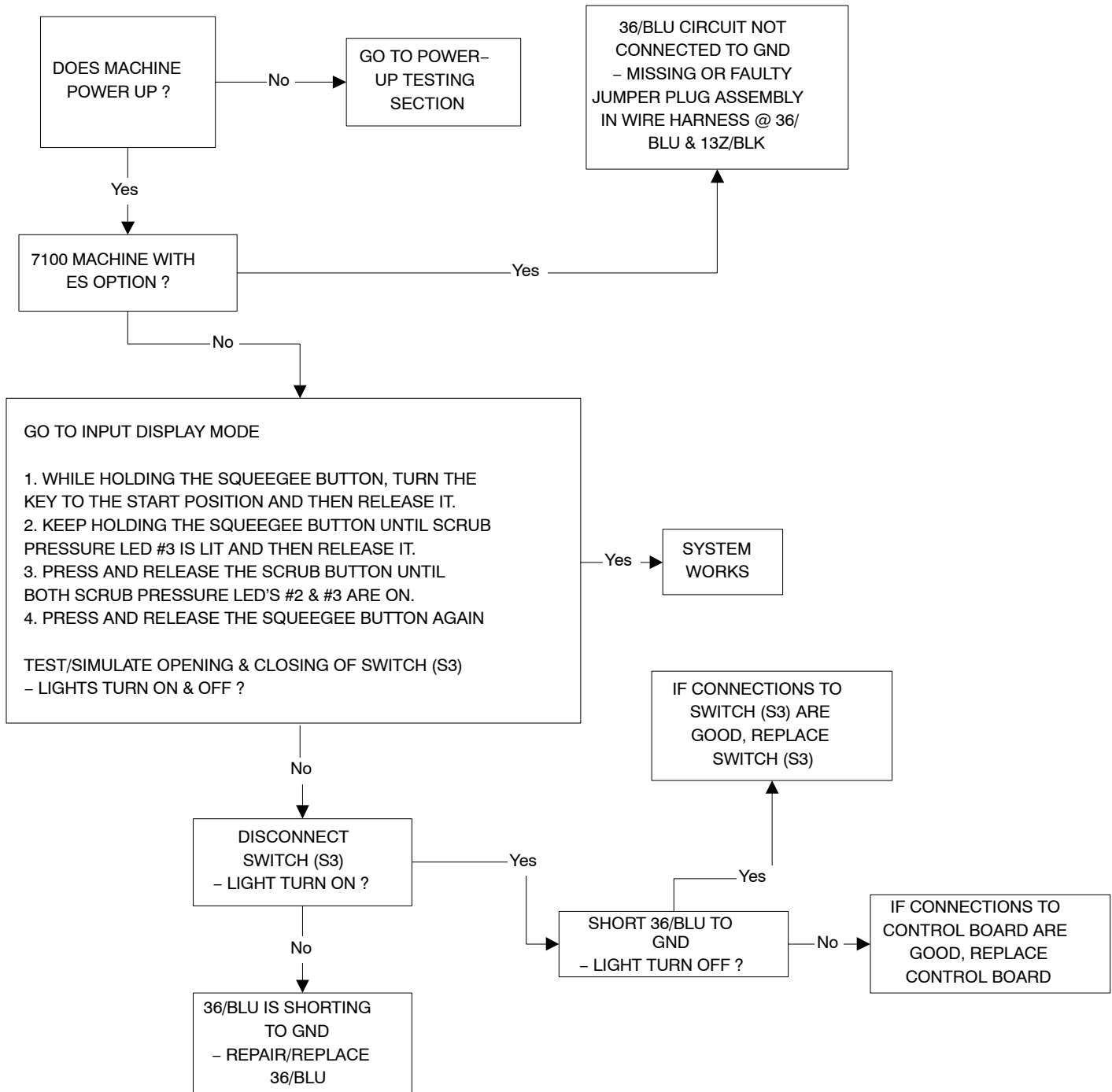

SOLUTION EMPTY

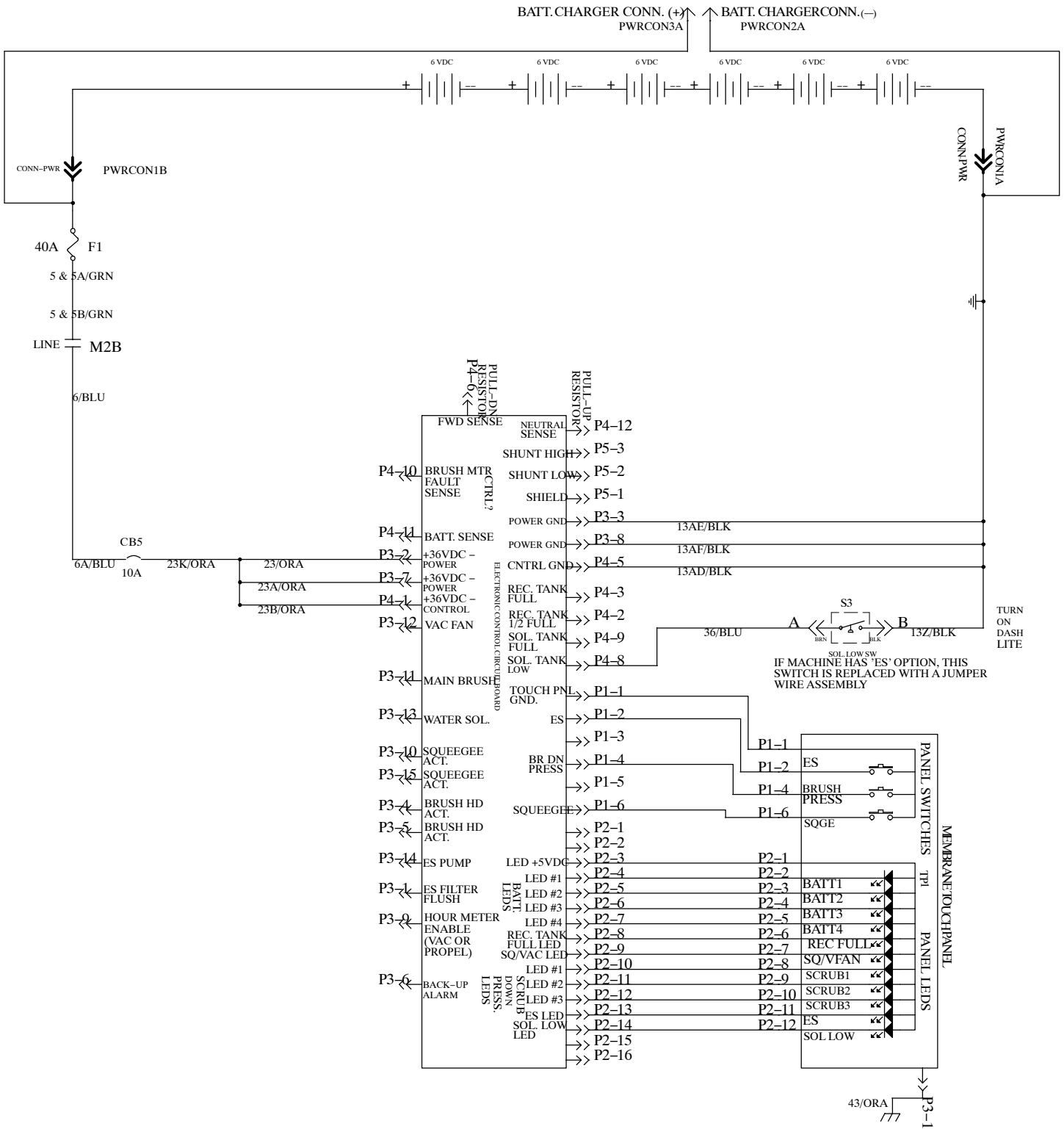



## SOLUTION VALVE

### OPERATION:

WHEN THE SCRUB BUTTON IS PUSHED, THE MACHINE ACTIVATES THE ONE TOUCH SCRUB SYSTEM:

- THE SQUEEGEE LOWERS AND THE VAC FAN TURNS ON
- THE SCRUB HEAD COMES DOWN
- THE ES SYSTEM TURNS ON IF IT PREVIOUSLY WAS ON.

WHEN THE MACHINE PROPELS FORWARD:

- THE BRUSHES TURNS ON
- THE SOLUTION VALVE TURNS ON AND IS REGULATED BY THE FLOW CONTROL LEVER ON THE CONTROL PANEL

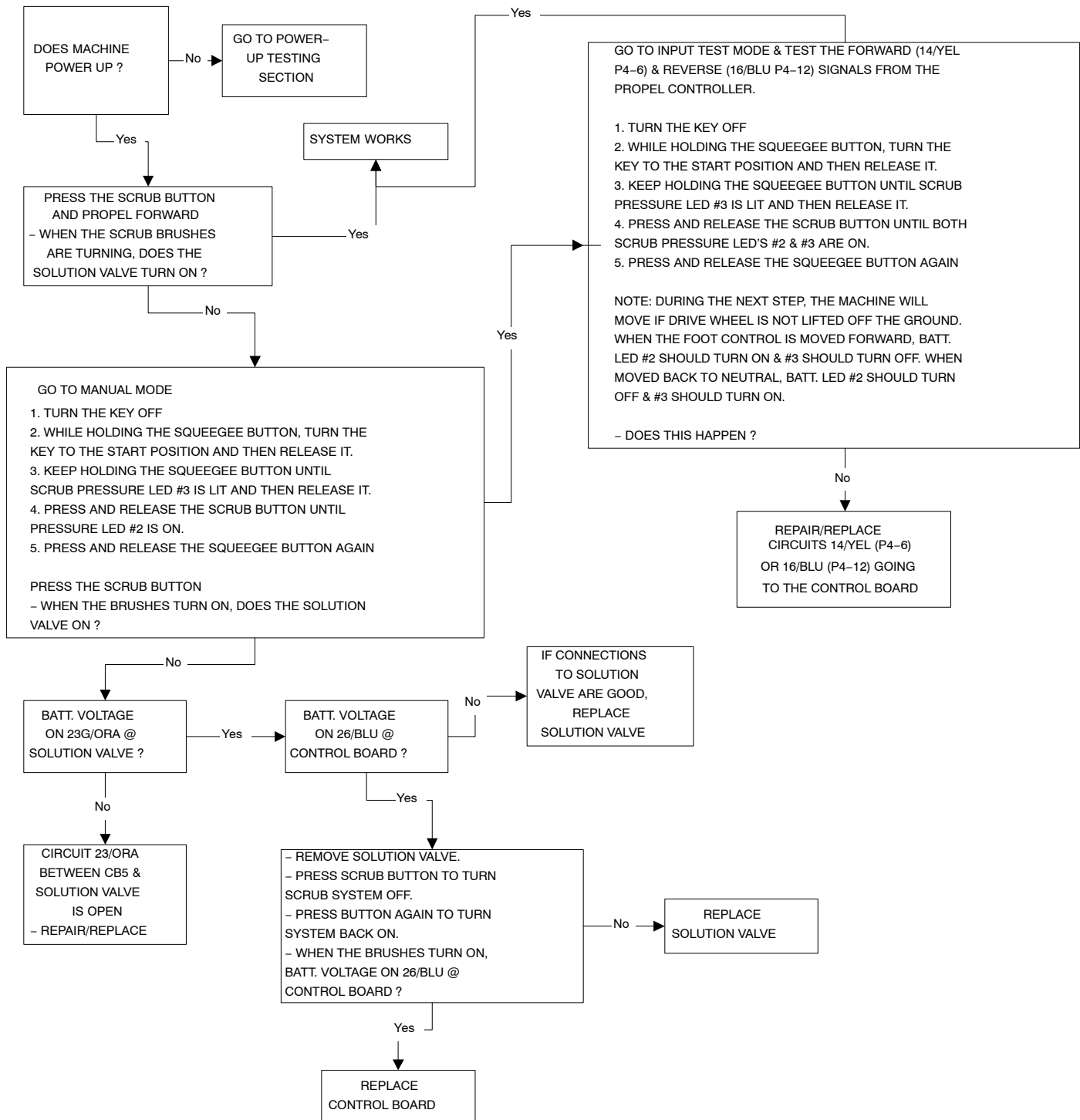

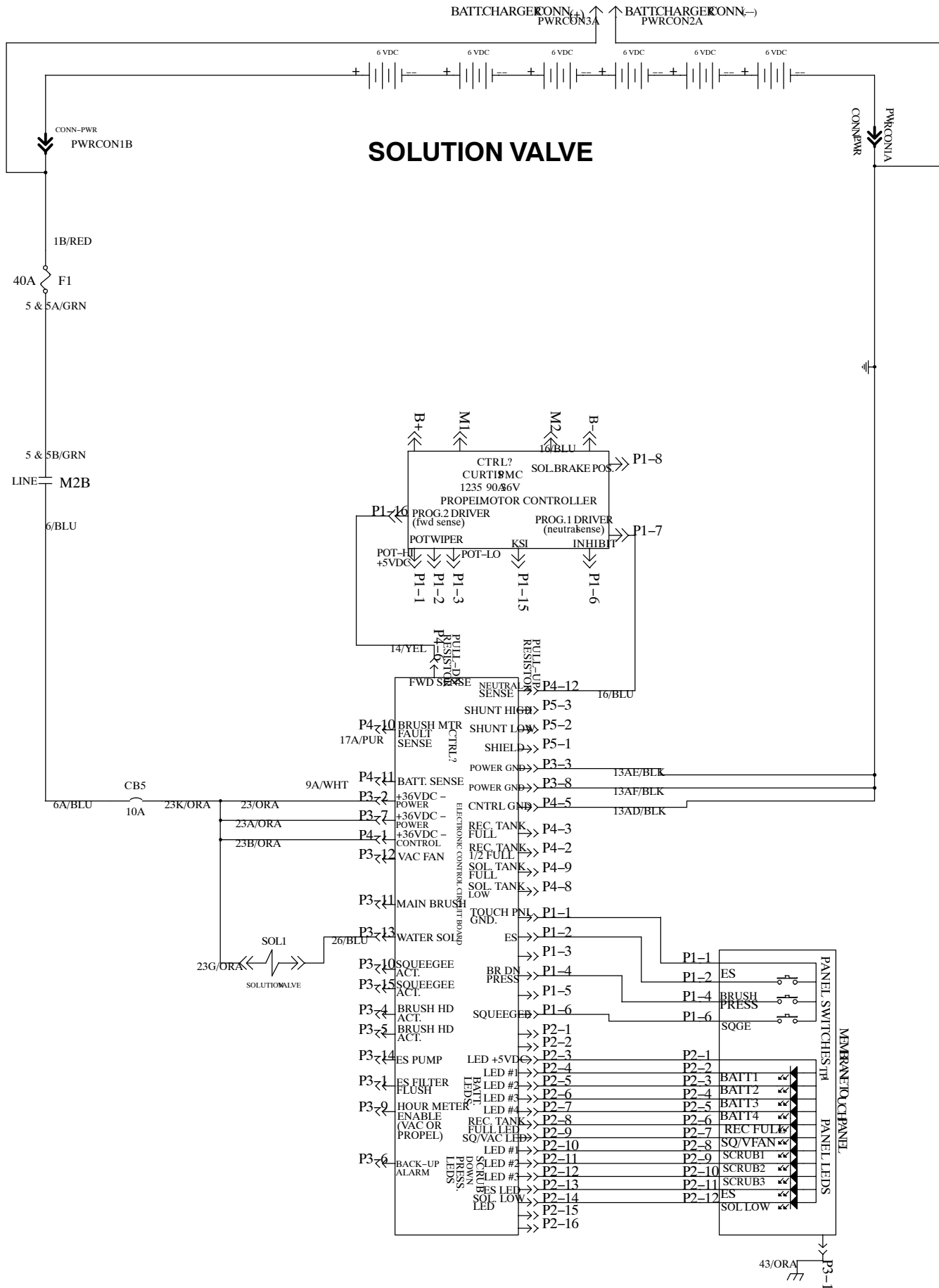

## SQUEEGEE SYSTEM

### OPERATION:

TO LOWER THE SQUEEGEE ACTUATOR, THE FOLLOWING CONDITIONS MUST OCCUR:

- VACUUM FAN/SQUEEGEE SYSTEM SELECTED ON THE TOUCH PANEL
- MACHINE IN NEUTRAL OR FORWARD POSITION
- NO "LOW BATTERY" CONDITION SENSED
- NO "FULL RECOVERY TANK" CONDITION SENSED

WHILE THE SQUEEGEE ACTUATOR LOWERS OR LIFTS:

- TO LOWER, 27/PUR (P3-10) RECEIVES POSITIVE VOLTAGE WHILE 28/GRY (P3-15) IS PULSED LOW
- TO LIFT, 28/GRY (P3-15) RECEIVES POSITIVE VOLTAGE WHILE 27/PUR (P3-10) IS PULSED LOW

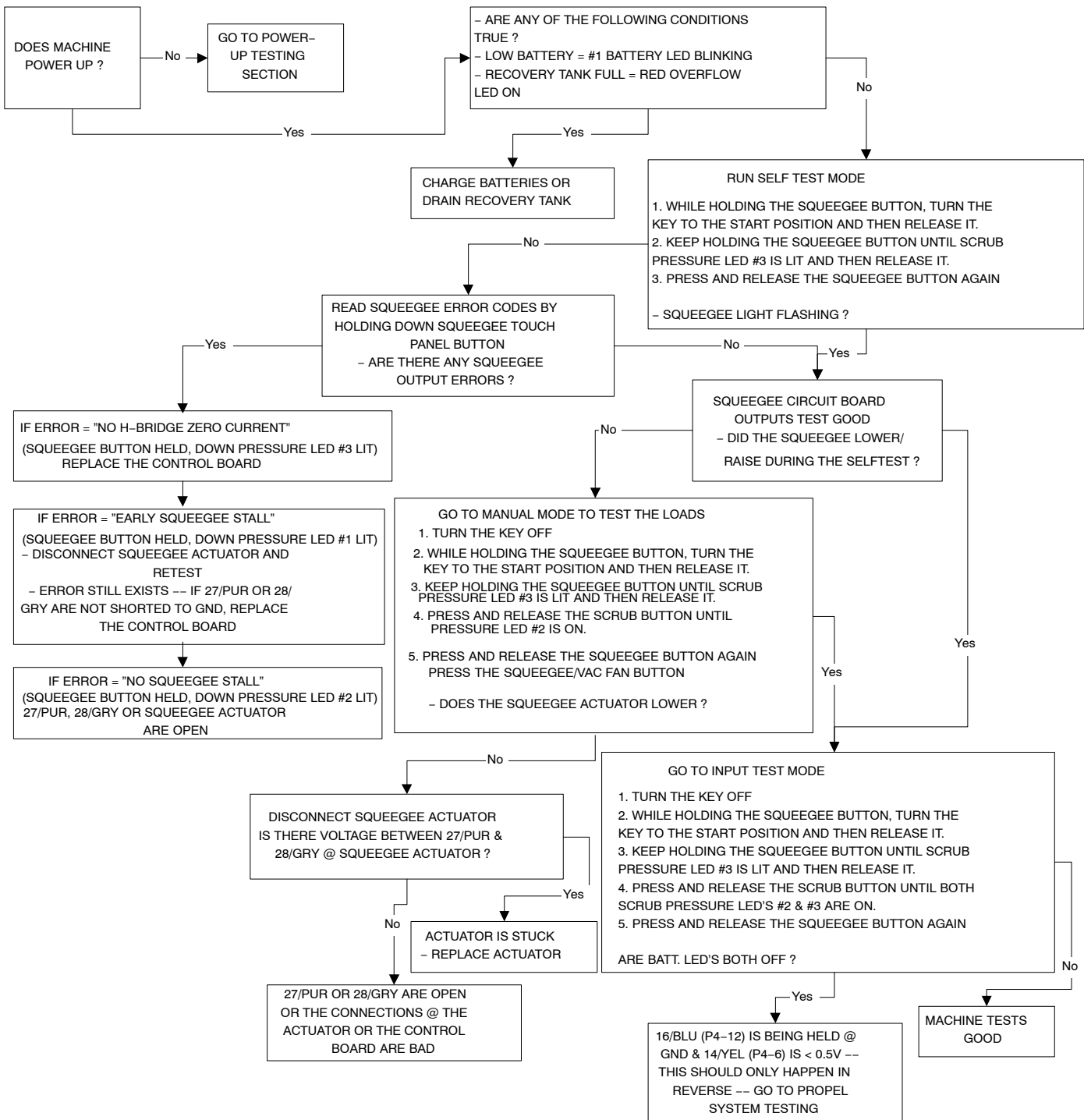

SQUEEGEE SYSTEM

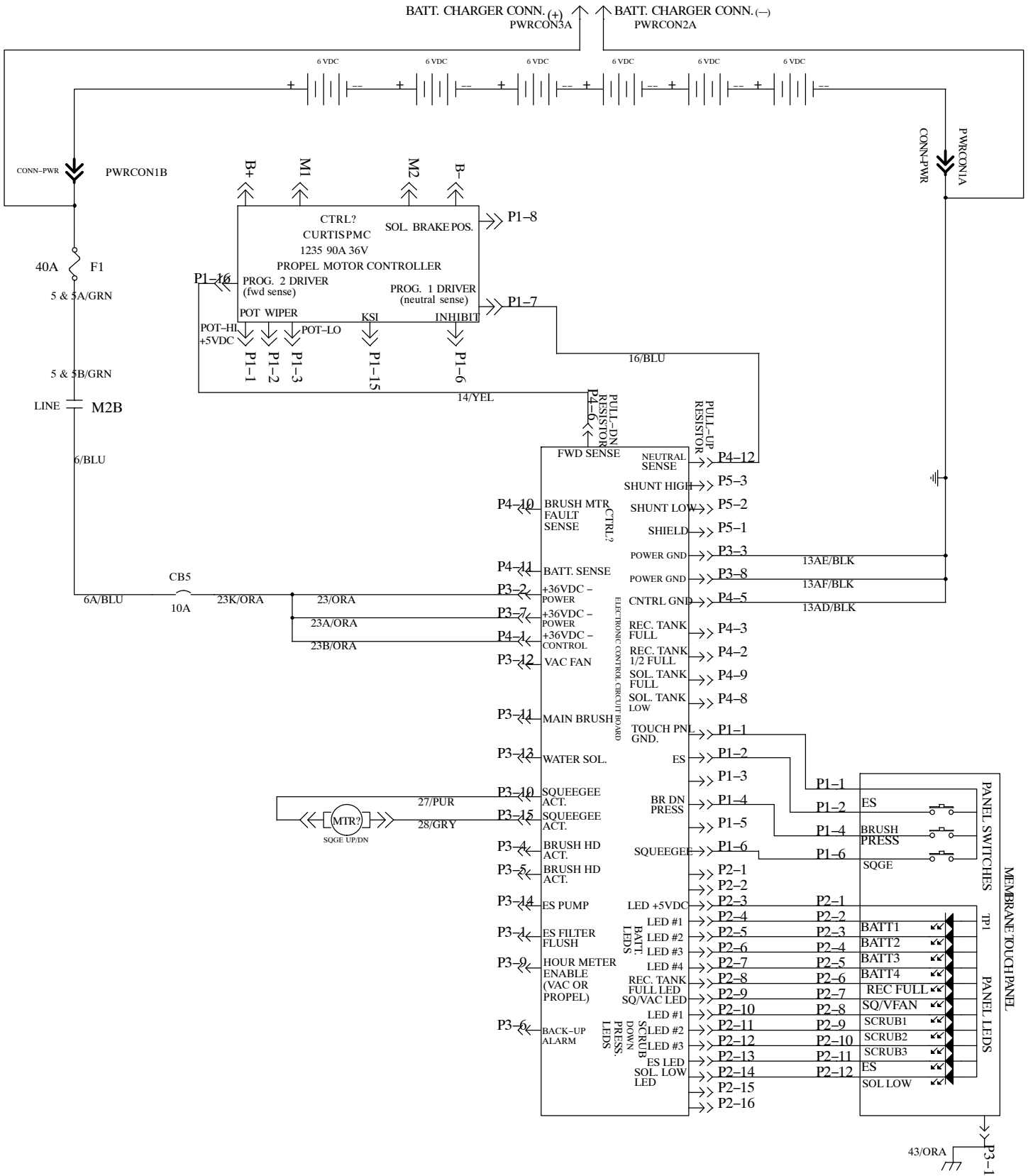

## TOUCH PANEL

## OPERATION OF LEDS: (MEASUREMENTS TAKEN @ 12 CONDUCTOR TOUCH PANEL CONNECTOR)

P2-1 = +5VDC TO EACH LED

P2-2 - P2-12 = WITH RIBBON CABLE CONNECTED, CONTROL BOARD WILL DROP VOLTAGE @ THESE PINS RANGING FROM 3.6V-5V, WHEN AN LED IS NOT LIT, DOWN TO 3V, WHEN IT IS.

## OPERATION OF SWITCHES: (MEASUREMENTS TAKEN @ 6 CONDUCTOR TOUCH PANEL CONNECTOR)

P1- 1 = SUPPLIES GND PATH TO EACH MEMBRANE SWITCH

P1- 2 = CONNECTED TO GND WHEN ES SWITCH IS PUSHED

P1- 4 = CONNECTED TO GND WHEN SCRUB SWITCH IS PUSHED

P1- 6 = CONNECTED TO GND WHEN SQUEEGEE SWITCH IS PUSHED

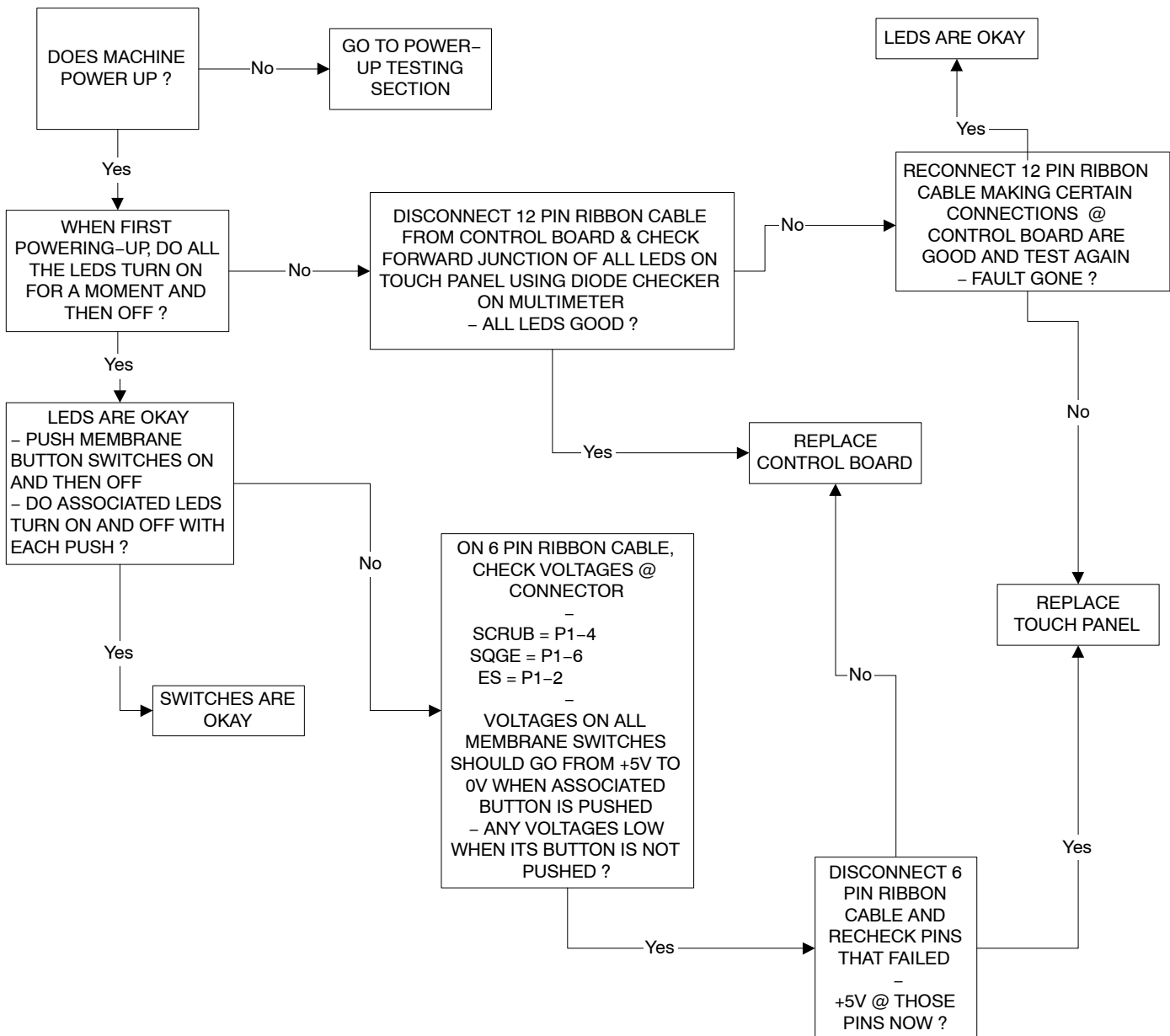

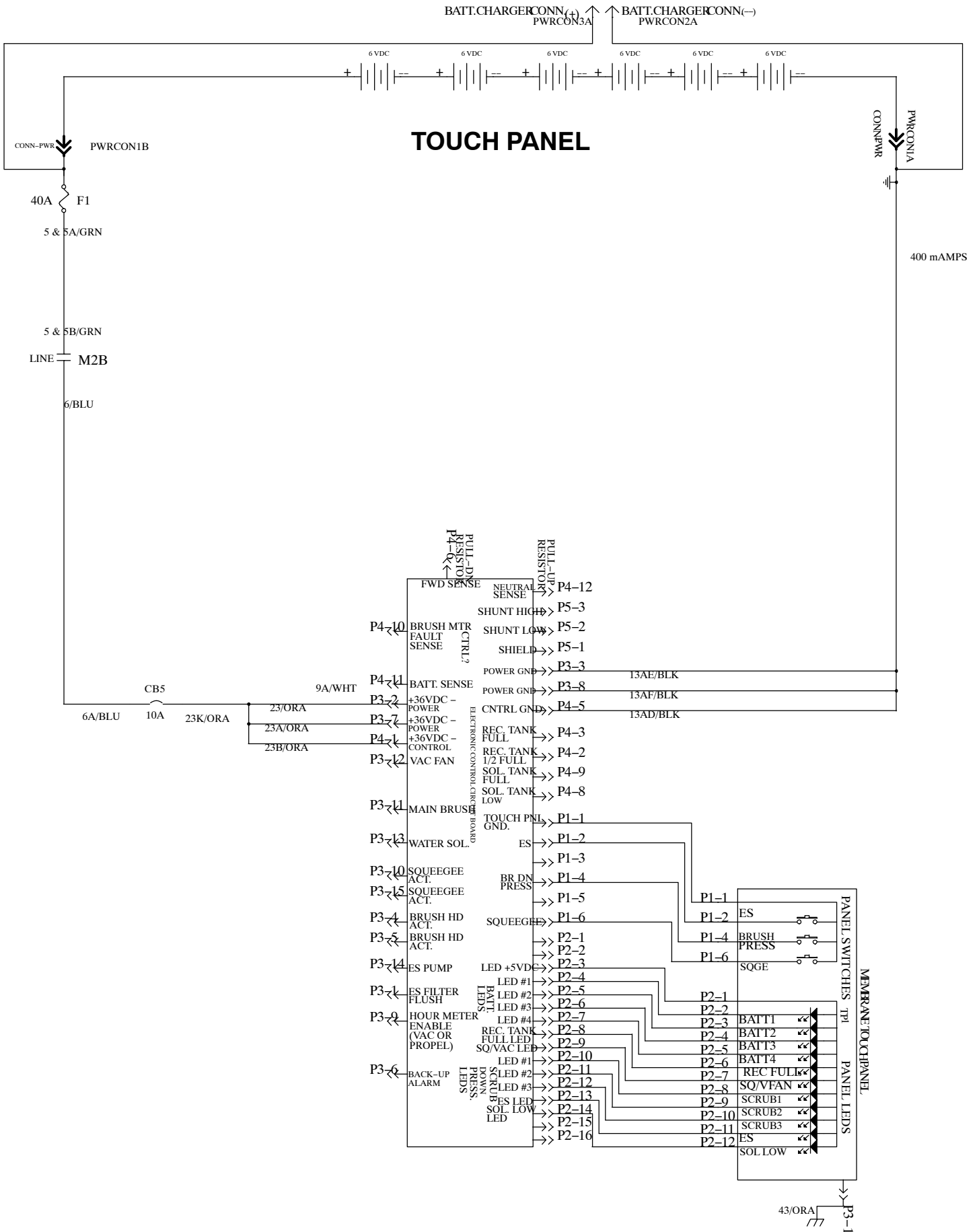

## VACUUM FAN

### OPERATION:

TO ENABLE THE VACUUM FAN, THE FOLLOWING CONDITIONS MUST OCCUR:

1. VACUUM FAN/SQUEEGEE SYSTEM IS SELECTED ON THE TOUCH PANEL
2. MACHINE IS IN NEUTRAL OR FORWARD POSITION
3. "LOW BATTERY" CONDITION NOT PRESENT
4. "FULL RECOVERY TANK" CONDITION NOT PRESENT

FOR VACUUM MOTOR(S) TO TURN ON:

1. 24/YEL MUST BE CONNECTED TO GND THRU CONTROL BOARD CONNECTION (P3-12), TURNING ON M3 CONTACTOR
2. THE NOW CLOSED CONTACTS OF M3 CONTACTOR SUPPLY BATTERY POWER TO THE VACUUM FAN MOTOR(S)

