

# Consolidated\* Valves

# 3900 MPV Series

## Pilot-Operated Safety Relief Valve

A unique design that combines enhanced performance, capabilities and features within an economical, modular assembly.



# Table of Contents

Conversion Table.....	3
Scope of Design - 3900 Flanged Series Overview.....	4-5
Scope of Design - Valve Selection.....	6-8
Main Valve Materials.....	9-11
Soft Goods Selection Chart.....	12
Pressure and Temperature Limits.....	13
Pop Pilot Product Operation.....	14-15
Pop Pilot Materials (PV).....	16-17
Modulating Pilot Product Operation.....	18-19
Modulating Pilot Materials.....	20-22
Pilot Design Options.....	23-24
Dirty Service Option.....	25
Piping Configurations.....	26-50
Dimensions and Weights.....	51-55
Pressure / Temperature.....	56
Capacities - Air.....	57-59
Capacities - Water.....	60-62
Capacities - Steam.....	63-65
Valve Installation.....	66
Valve Configuration Code.....	67-70
Ordering a 3900 Series MPV Safety Relief Valve.....	71

GE provides a full range of Consolidated\* pressure relief valve styles, sizes, options and configurations for multiple industries, applications, environments, and media. From spring-actuated to pilot-operated, each pressure relief valve is configured to offer safer process flow control in harsh environments.

## Conversion Table

All the USCS values are converted to metric values using the following conversion factors:		
Metric values using the following conversion factors:	Conversion Factor	Metric Unit
in.	25.4	mm
lb.	0.4535924	kg
in <sup>2</sup>	6.4516	cm <sup>2</sup>
ft <sup>3</sup> /min	0.02831685	m <sup>3</sup> /min
gal/min	3.785412	L/min
lb/hr	0.4535924	kg/hr
psig	0.06894757	barg
ft lb	1.3558181	Nm
°F	5/9 (°F-32)	°C

# Scope of Design

## 3900 Flanged Series Valve Overview

Pressure Limits <sup>1</sup>						
Product Type	Pilot Type	Minimum		Maximum		Service
		psig	barg	psig	barg	
3900	39PV	15	1.03	3750	258.55	gas/liquid
3900	39MV	15	1.03	3750	258.55	gas/liquid
3900	39PVSS	15	1.03	750	51.71	steam
3900	39MVSS	15	1.03	750	51.71	steam

Temperature Limits <sup>1 and 2</sup>						
Product Type	Pilot Type	Minimum		Maximum		Service
		°F	°C	°F	°C	
3900	39PV	-40	-40.0	505	262.8	gas/liquid
3900	39MV	-40	-40.0	505	262.8	gas/liquid
3900	39PVSS	212	100.0	505	262.8	steam
3900	39MVSS	212	100.0	505	262.8	steam

Soft Goods Guide <sup>3</sup>																	
Service	Material	Pilot Valve and Modulator								Main Valve							
		Temperature Range				Pressure Range				Temperature Range				Pressure Range			
		°F		°C		psig		barg		°F		°C		psig		barg	
		min.	max.	min.	max.	min.	max.	min.	max.	min.	max.	min.	max.	min.	max.	min.	max.
liquid/gas	nitrile (Buna-N)	-40	250	-40.0	121.1	15	3750	1.03	258.55	-40	250	-40.0	121.1	15	1500	1.03	103.42
liquid/gas	fluorocarbon (Viton)	-15	400	-26.1	204.4	15	3750	1.03	258.55	-15	400	-26.1	204.4	15	1500	1.03	103.42
liquid/gas	ethylene propylene	-40	400	-40.0	204.4	15	3750	1.03	258.55	-40	500	-40.0	260.0	15	1500	1.03	103.42
liquid/gas	Kalrez®	-40	400	-40.0	204.4	15	3750	1.03	258.55	-40	505	-40.0	262.8	15	1500	1.03	103.42
liquid/gas	Teflon	212	505	100.0	262.8	50	3750	3.45	258.55	-40	505	-40.0	262.8	50	3750	3.45	258.55
liquid/gas	neoprene	N/A	N/A	N/A	N/A	N/A	N/A	N/A	N/A	-45	300	-42.8	148.9	15	800	1.03	55.16
liquid/gas	silicone	N/A	N/A	N/A	N/A	N/A	N/A	N/A	N/A	-40	437	-40.0	225.0	15	400	1.03	27.58
liquid/gas	Chemraz®	N/A	N/A	N/A	N/A	N/A	N/A	N/A	N/A	-20	450	-28.9	232.2	15	1500	1.03	103.42
steam	ethylene propylene	212	500	100.0	260.0	15	49	1.03	3.38	212	500	100.0	260.0	15	49	1.03	3.38
steam	Teflon®	212	505	100.0	262.8	50	3750	3.45	258.55	212	505	100.0	262.8	50	750	3.45	51.71

### Notes:

1. The above table is general in nature and is to be used as a guideline only.
2. Refer to the "Pressure/Temperature" Chart on page 3900.56 for actual pressure limits at a given temperature by pressure class and materials of construction.
3. Refer to the "Soft Goods Selection" Chart on page 3900.12 for material selection for a given pressure, temperature, fluid type, durometer hardness, and orifice size.

# Scope of Design

## 3900 Flanged Series Valve Overview

Options		
Options	39PV	39MV
Manual Blowdown Valve (standard for steam service)	Yes	Yes
Backflow Preventer	Yes	Yes
Remote Sensing	Yes	Yes
Remote Pilot Mounting	Yes	Yes
Optional Sensing Line	Yes	Yes
Dual Pilots	Yes	Yes
Dual Filters	Yes	Yes
Pressure Differential Switch	Yes	Yes
Bonnet (vented)	Yes	Yes
Metal Spring Cover (encloses yoke and spring)	Yes	Yes
High Capacity Line Filter (with flush valve)	Yes	Yes
Remote Actuated Blowdown	Yes	Yes

Applications				
		Options	39PV	39MV
Type				
Pop Action - Non Flowing			Yes	No
Modulating - Non Flowing			No	Yes
Media				
Air, Gas			Yes	Yes
Vapor			Yes	Yes
Dirty Vapor (filter required)			Yes	Yes
Steam			Yes	Yes
Liquid			Yes	Yes
Operational Conditions				
Icing			Yes	Yes
Pulsations			Yes	Yes
Reduces Water Hammer (when valve closes)			Yes	Yes
Operational Performance				
Pressure Range:		15 - 3750 psig (1.03 - 258.55 barg) (Gas/Liquid/Steam)	Yes	Yes
		15 - 750 psig (1.03 - 51.71 barg) (Steam)	Yes	Yes
Blowdown:		3 percent		Yes
		5 percent	Yes	
Main Valve Seat Tightness:				
		Bubble tight at 99 percent of set pressure	Yes	Yes
Back Pressure (vent piped to main valve outlet) <sup>1</sup> :				
		Variable - percent of Set Pressure	15 percent	65 percent
		Constant - percent of Set Pressure	Note 2	65 percent
Back Pressure (with pilot vented to atmosphere) <sup>1</sup> :				
		Variable - percent of Set Pressure	65 percent	65 percent
		Constant - percent of Set Pressure	65 percent	65 percent
Back Pressure (with pilot vented to body bowl) <sup>1</sup> :				
		Variable - percent of Set Pressure	15 percent	65 percent
		Constant - percent of Set Pressure	65 percent	65 percent
Back Pressure (vent not piped to main valve outlet) <sup>1</sup> :			Note 3	Note 3

### Notes:

1. Review the outlet flange rating and review the capacity correction factor.
2. A cold differential test pressure (CDTP) must be applied for a 39PV with constant back pressure over 15 percent of set pressure.
3. Contact factory for permissible backpressure limits when pilot vent is piped to valve outlet.

# Scope of Design

## Valve Selection

Standard Bore Valve Connections										
Valve Size		Valve Type	Orifices	Inlet Flange			Outlet Flange			Outlet Type
				Size		Class	Size		Class	
in.	mm			in.	mm			in.		mm
1.00	25.4	3905	D, E & F	1.00	25.4	150	2.00	50.8	150	Single
1.00	25.4	3910	D, E & F	1.00	25.4	300	2.00	50.8	150	Single
1.00	25.4	3912	D, E & F	1.00	25.4	600	2.00	50.8	150	Single
1.00	25.4	3914	D, E & F	1.00	25.4	900	2.00	50.8	300	Single
1.00	25.4	3916	D, E & F	1.00	25.4	1500	2.00	50.8	300	Single
1.00	25.4	3918	D, E & F	1.00	25.4	2500	2.00	50.8	300	Single
1.50	38.1	3905	D, E & F	1.50	38.1	150	2.00	50.8	150	Single
1.50	38.1	3910	D, E & F	1.50	38.1	300	2.00	50.8	150	Single
1.50	38.1	3912	D, E & F	1.50	38.1	600	2.00	50.8	150	Single
1.50	38.1	3914	D, E & F	1.50	38.1	900	2.00	50.8	300	Single
1.50	38.1	3916	D, E & F	1.50	38.1	1500	2.00	50.8	300	Single
1.50	38.1	3918	D, E & F	1.50	38.1	2500	2.00	50.8	300	Single
1.50	38.1	3905	G & H	1.50	38.1	150	3.00	76.2	150	Single
1.50	38.1	3910	G & H	1.50	38.1	300	3.00	76.2	150	Single
1.50	38.1	3912	G & H	1.50	38.1	600	3.00	76.2	150	Single
1.50	38.1	3914	G & H	1.50	38.1	900	3.00	76.2	300	Single
1.50	38.1	3916	G & H	1.50	38.1	1500	3.00	76.2	300	Single
1.50	38.1	3918	G & H	1.50	38.1	2500	3.00	76.2	300	Single
2.00	50.8	3905	G, H & J	2.00	50.8	150	3.00	76.2	150	Single
2.00	50.8	3910	G, H & J	2.00	50.8	300	3.00	76.2	150	Single
2.00	50.8	3912	G, H & J	2.00	50.8	600	3.00	76.2	150	Single
2.00	50.8	3914	G, H & J	2.00	50.8	900	3.00	76.2	300	Single
2.00	50.8	3916	G, H & J	2.00	50.8	1500	3.00	76.2	300	Single
2.00	50.8	3918	G, H & J	2.00	50.8	2500	3.00	76.2	300	Single
3.00	76.2	3905	J, K & L	3.00	76.2	150	4.00	101.6	150	Single
3.00	76.2	3910	J, K & L	3.00	76.2	300	4.00	101.6	150	Single
3.00	76.2	3912	J, K & L	3.00	76.2	600	4.00	101.6	150	Single
3.00	76.2	3914	J, K & L	3.00	76.2	900	4.00	101.6	300	Single
3.00	76.2	3916	J, K & L	3.00	76.2	1500	4.00	101.6	300	Single
3.00	76.2	3918	J, K & L	3.00	76.2	2500	4.00	101.6	300	Single
4.00	101.6	3905	L, M, N & P	4.00	101.6	150	6.00	152.4	150	Single
4.00	101.6	3910	L, M, N & P	4.00	101.6	300	6.00	152.4	150	Single
4.00	101.6	3912	L, M, N & P	4.00	101.6	600	6.00	152.4	150	Single
4.00	101.6	3914	L, M, N & P	4.00	101.6	900	6.00	152.4	300	Single
4.00	101.6	3916	L, M, N & P	4.00	101.6	1500	6.00	152.4	300	Single
6.00	152.4	3905	Q & R	6.00	152.4	150	8.00	203.2	150	Single
6.00	152.4	3910	Q & R	6.00	152.4	300	8.00	203.2	150	Single
6.00	152.4	3912	Q & R	6.00	152.4	600	8.00	203.2	150	Single
8.00	203.2	3905	T	8.00	203.2	150	10.00	254.0	150	Single
8.00	203.2	3910	T	8.00	203.2	300	10.00	254.0	150	Single
8.00	203.2	3912	T	8.00	203.2	600	10.00	254.0	150	Single

# Scope of Design

## Valve Selection

Full Bore Valve Connections											
Valve Size		Valve Type	Orifices	Inlet Flange			Outlet Flange			Outlet Type	
				Size		Class	Size		Class		
in.	mm			in.	mm		in.	mm			
1.50	38.1	3905B	1.5 - FB	1.50	38.1	150	2.00	50.8	150	Single	
1.50	38.1	3910B	1.5 - FB	1.50	38.1	300	2.00	50.8	150	Single	
1.50	38.1	3912B	1.5 - FB	1.50	38.1	600	2.00	50.8	150	Single	
1.50	38.1	3914B	1.5 - FB	1.50	38.1	900	2.00	50.8	300	Single	
1.50	38.1	3916B	1.5 - FB	1.50	38.1	1500	2.00	50.8	300	Single	
1.50	38.1	3918B	1.5 - FB	1.50	38.1	2500	2.00	50.8	300	Single	
2.00	50.8	3905B	2.0 - FB	2.00	50.8	150	3.00	76.2	150	Single	
2.00	50.8	3910B	2.0 - FB	2.00	50.8	300	3.00	76.2	150	Single	
2.00	50.8	3912B	2.0 - FB	2.00	50.8	600	3.00	76.2	150	Single	
2.00	50.8	3914B	2.0 - FB	2.00	50.8	900	3.00	76.2	300	Single	
2.00	50.8	3916B	2.0 - FB	2.00	50.8	1500	3.00	76.2	300	Single	
2.00	50.8	3918B	2.0 - FB	2.00	50.8	2500	3.00	76.2	300	Single	
3.00	76.2	3905B	3.0 - FB	3.00	76.2	150	4.00	101.6	150	Single	
3.00	76.2	3910B	3.0 - FB	3.00	76.2	300	4.00	101.6	150	Single	
3.00	76.2	3912B	3.0 - FB	3.00	76.2	600	4.00	101.6	150	Single	
3.00	76.2	3914B	3.0 - FB	3.00	76.2	900	4.00	101.6	300	Single	
3.00	76.2	3916B	3.0 - FB	3.00	76.2	1500	4.00	101.6	300	Single	
3.00	76.2	3918B	3.0 - FB	3.00	76.2	2500	4.00	101.6	300	Single	
4.00	101.6	3905B	4.0 - FB	4.00	101.6	150	6.00	152.4	150	Single	
4.00	101.6	3910B	4.0 - FB	4.00	101.6	300	6.00	152.4	150	Single	
4.00	101.6	3912B	4.0 - FB	4.00	101.6	600	6.00	152.4	150	Single	
4.00	101.6	3914B	4.0 - FB	4.00	101.6	900	6.00	152.4	300	Single	
4.00	101.6	3916B	4.0 - FB	4.00	101.6	1500	6.00	152.4	300	Single	
6.00	152.4	3905B	6.0 - FB	6.00	152.4	150	8.00	203.2	150	Double	
6.00	152.4	3910B	6.0 - FB	6.00	152.4	300	8.00	203.2	150	Double	
6.00	152.4	3912B	6.0 - FB	6.00	152.4	600	8.00	203.2	150	Double	
8.00	203.2	3905B	8.0 - FB	8.00	203.2	150	10.00	254.0	150	Double	
8.00	203.2	3910B	8.0 - FB	8.00	203.2	300	10.00	254.0	150	Double	
8.00	203.2	3912B	8.0 - FB	8.00	203.2	600	10.00	254.0	150	Double	
10.00	254.0	3905B	10.0 - FB	10.00	254.0	150	10.00	254.0	150	Double	
10.00	254.0	3910B	10.0 - FB	10.00	254.0	300	10.00	254.0	150	Double	
10.00	254.0	3905XB	10.0 - FB	10.00	254.0	150	14.00	355.6	150	Single	
10.00	254.0	3910XB	10.0 - FB	10.00	254.0	300	14.00	355.6	150	Single	
12.00	304.8	3905XB	12.0 - FB	12.00	304.8	150	16.00	406.4	150	Single	
12.00	304.8	3910XB	12.0 - FB	12.00	304.8	300	16.00	406.4	150	Single	

# Scope of Design

## Valve Selection

Valve Bore Orifice Areas					
Bore Type	Orifice Designation	ASME		API	
		in <sup>2</sup>	cm <sup>2</sup>	in <sup>2</sup>	cm <sup>2</sup>
Standard Bore	D	0.128	0.825	0.110	2.794
	E	0.228	1.470	0.196	4.978
	F	0.366	2.360	0.307	7.798
	G	0.585	3.774	0.503	12.776
	H	0.913	5.888	0.785	19.939
	J	1.496	9.652	1.287	32.690
	K	2.138	13.794	1.838	46.685
	L	3.317	21.400	2.853	72.466
	M	4.186	27.006	3.600	91.440
	N	5.047	32.561	4.340	110.236
	P	7.417	47.852	6.380	162.052
	Q	12.850	82.903	11.050	280.670
	R	18.600	120.000	16.000	406.400
T	30.210	194.903	26.000	660.400	
Full Bore	1.5 - FB	1.622	10.464	N/A	N/A
	2.0 - FB	2.764	17.832	N/A	N/A
	3.0 - FB	6.321	40.781	N/A	N/A
	4.0 - FB	10.760	69.419	N/A	N/A
	6.0 - FB	24.950	160.967	N/A	N/A
	8.0 - FB	44.180	285.032	N/A	N/A
	10.0 - FB	69.940	451.225	N/A	N/A
	12.0 - FB	111.930	722.128	N/A	N/A



# Main Valve Materials

## 3900 Series Valve Materials Overview

The main valve has six basic components. Assembly and disassembly are accomplished through top entry. As long as there is no pressure in the system, routine maintenance, such as replacement of O-rings and seals, can be done with the valve in place, eliminating the need for cranes and additional manpower.

### Base

The base is cast with integral flanges. It forms the main structure and is a pressure boundary component, as it is exposed to process media. To ensure integrity and reliability, all base castings are manufactured to the latest ASME Boiler & Pressure Vessel Codes. The standard materials are Grade WCC carbon steel, and Grade CF8M 316 stainless steel. Other materials such as Monel, Hastelloy, and additional code-approved materials are available to satisfy more demanding requirements. The discharge side of the body is drilled and tapped for pilot venting. If the pilot is vented to the atmosphere, a pipe plug is installed to secure this area.

### Nozzle

The 316 stainless steel nozzle performs two functions: It forms the lower sealing surface, and it controls the capacity. The orifice is machined into the nozzle, ensuring that rated flow capacities will be obtained should an overpressure condition occur. The nozzle is threaded or bolted into the body and sealed with an O-ring. Threading or bolting the nozzle facilitates easy removal for repair or replacement.

### Guide

This one-piece 316 stainless steel guide ensures true alignment of the disc and nozzle for positive, bubble-tight sealing. The heavy guide construction is designed to prevent warping or egging when the valve is in service.

### Disc

The disc is 316 stainless steel. An O-ring (part 10) is used for isolating the dome chamber when used on air, gas or liquid service. A spring energized Teflon® seal (part 17) is used on the top side of the disc for steam service. A graphite impregnated Teflon® guide ring (or rings) (part 16) provides a low coefficient of friction for the guiding function between the disc and guide. An O-ring seat (part 12) performs the primary sealing function for the disc to ensure bubble tightness. The metal-to-metal stop for the seat allows the valve to function even if the O-ring is damaged or destroyed.

Two unique features distinguish GE's O-ring seat seal safety relief valve from other designs. These features are the 50 degree metal-to-metal load bearing seats and the slotted O-ring retainer.

There are three essentials to a tighter and more secure seal:

- 1. Concentric Alignment**  
The nozzle bore and O-ring retainer are both machined to an angle of 50 degrees. This ensures that as the valve disc opens and closes the O-ring is aligned concentrically against the lip of the nozzle. Close tolerance between the nozzle and the body also helps to ensure a tight seal when the valve is closed.
- 2. Maximum Sealing Force**  
On the back side of the O-ring retainer, there are two small slots. When the valve is closed, process media enters between the machined seat of the nozzle and the O-ring retainer, and proceeds up the slots behind the O-ring. This pressure forces the O-ring against the lip of the nozzle and the curved recess of the disc.  
  
As the pressure within the valve rises to the set point, the O-ring is pressed tightly against the nozzle to maintain maximum sealing force until valve set pressure is reached.
- 3. O-ring Retention**  
When the valve opens, the pressure behind the O-ring escapes from these same two slots on the O-ring retainer. This prevents the O-ring from being ejected. Additionally, the O-ring encapsulating retainer prevents the O-ring from being ejected by the high velocity, low pressure discharge inside the upper valve body.

### Cover Plate

The cover plate secures the guide and seals the main body. Each cover plate is drilled and tapped for eye bolts which are used for ease of assembly or disassembly of the main valve and for handling the assembled valve.

### Sensing Tube

The sensing tube is machined from 316 stainless hex bar stock and is threaded into the main body at a location below the nozzle. The sensing tube picks up media pressure and feeds this pressure through the sensing line to the pilot. To ensure proper orientation, one side of the hex is marked UP. This marking is to be oriented upward when the valve is sitting on its inlet flange. The pilot valve can also be installed in applications where remote sensing of pressure is used to actuate the pilot. In this case, the sensing tube is installed at the desired sensing location and connected by the sensing line to the pilot. The sensing tube port in the main valve is then sealed with a pipe plug.

### Other

The remaining parts -- studs, nuts, spring, nameplate, and lead seal -- complete the assembly of the main valve. A wire and lead seal are affixed to the pilot to protect the pilot valve adjustments.

# Main Valve Materials

3900 MPV Series Safety Relief Valve - Metal Seat

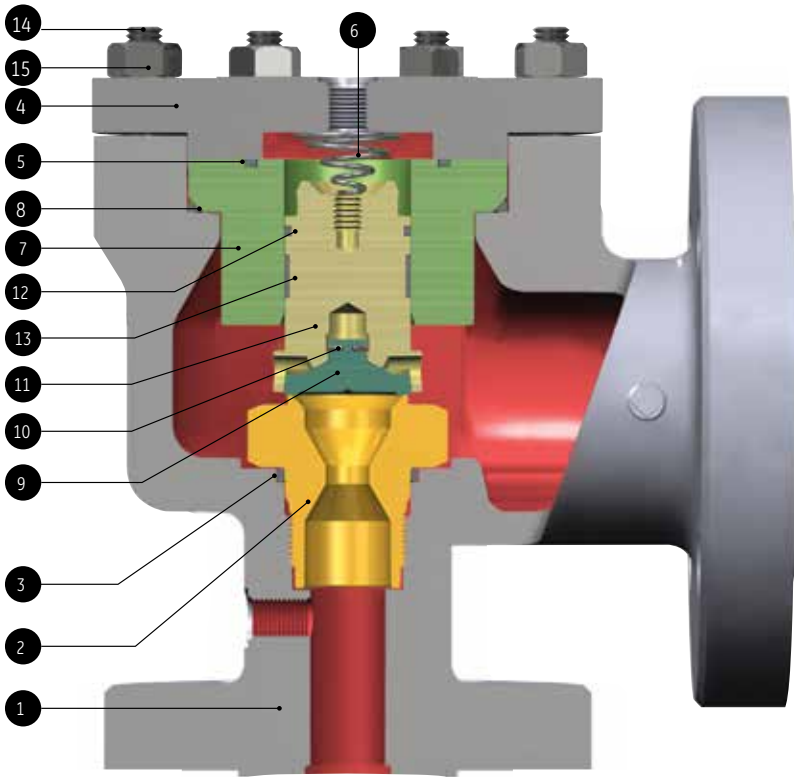

3900 MPV Series Safety Relief Valve - Soft Seat Liquid, Gas, and Air Service<sup>1</sup>

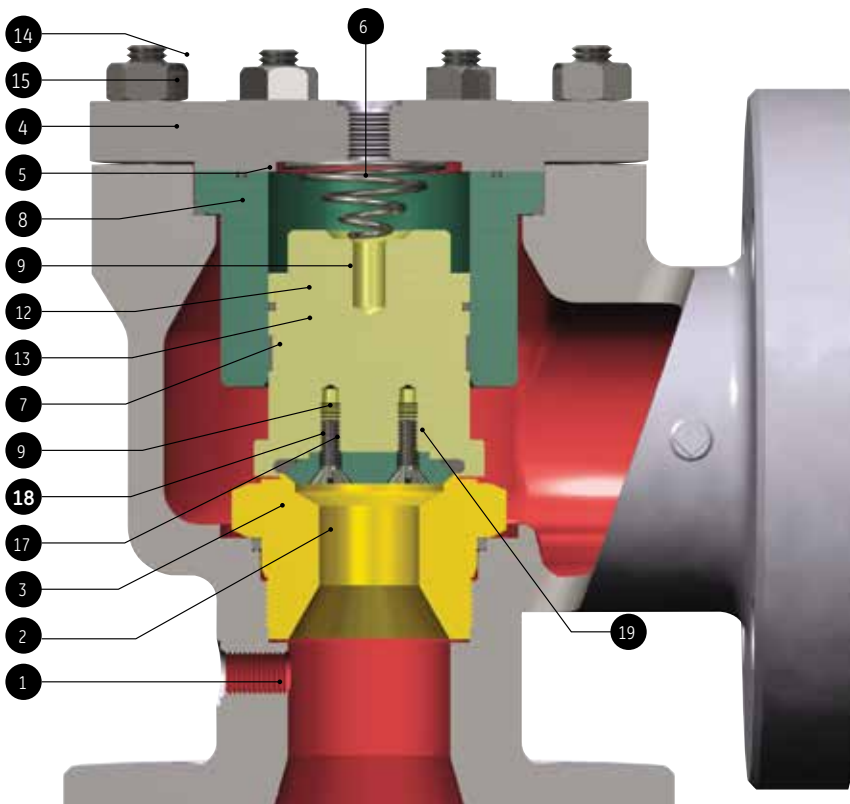

Steam Service<sup>2</sup>  
Liquid, Gas and Air Service<sup>3</sup>

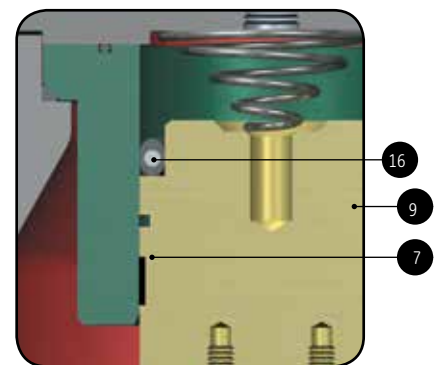

- Notes:**
1. Except when O-ring seat (12) is Teflon<sup>®</sup> and steam service below 50 psig (3.45 barg)
  2. for 50 psig (3.45 barg) and above.
  3. when O-ring Seat (18) is Teflon<sup>®</sup>

# Main Valve Materials

Main Valve Materials <sup>1</sup>					
Ref. No.		Part	Standard Material (CC)	Entirely Stainless (S4)	NACE (SG) - Internal Service Only
Metal Seat	Soft Seat				
1	1	Base	ASME SA216 WCC CS	ASME SA351 CF8M St.St.	ASME SA216 WCC CS
2	2	Nozzle	316 Stainless Steel	316 Stainless Steel	316 Stainless Steel
3	3	Nozzle O-ring	Teflon	Teflon	Teflon
4	4	Coverplate			
		(3905-3916) <sup>2</sup>	ASME SA299 Gr. A <sup>4</sup>	ASME SA479 316/316L St.St.	ASME SA299 Gr. A <sup>4</sup>
		(3918) <sup>3</sup>	ASME SA105 CS <sup>5</sup>	ASME SA240 316 St.St.	ASME SA105 CS <sup>5</sup>
5	5	Coverplate O-ring	Teflon	Teflon	Teflon
6	6	Spring	Inconel	Inconel	Inconel
7	7	Guide	316 Stainless Steel	316 Stainless Steel	316 Stainless Steel
8	8	Guide O-ring	Teflon	Teflon	Teflon
9	9	Disc			
		Metal Seat	316 Stainless Steel	316 Stainless Steel	316 Stainless Steel
		Thermodisc	616 Stainless Steel	616 Stainless Steel	616 Stainless Steel
		Soft Seat	316 Stainless Steel	316 Stainless Steel	316 Stainless Steel
10		Disc Retainer	Inconel X-750	Inconel X-750	Inconel X-750
11		Disc Holder	316 Stainless Steel	316 Stainless Steel	316 Stainless Steel
12	12	Disc Holder O-ring <sup>9</sup>	Teflon	Teflon	Teflon
13	13	Guide Rings	Teflon	Teflon	Teflon
14A <sup>6</sup>	14A <sup>6</sup>	Cap Screw <sup>7</sup>	ASME SA193 B7 Alloy Steel	ASME SA193 B8M St.St.	ASME SA193 B7 Alloy Steel
14B	14B	Stud <sup>8</sup>	ASME SA193 B7 Alloy Steel	ASME SA193 B8M St.St.	ASME SA193 B7 Alloy Steel
15	15	Nut <sup>8</sup>	ASME SA194 2H Alloy Steel	ASME SA193 B8M St.St.	ASME SA194 2H Alloy Steel
	16	Disc Seal <sup>10</sup>	Teflon	Teflon	Teflon
	17	O-ring Retainer	316 Stainless Steel	316 Stainless Steel	316 Stainless Steel
	18	Seat O-ring	Select	Select	Select
	19	Lock Screw	304 Stainless Steel	304 Stainless Steel	304 Stainless Steel
53	53	Sensing Tube <sup>6</sup>	316 Stainless Steel	316 Stainless Steel	316 Stainless Steel
54	54	Sensing Line Tubing <sup>6</sup>	316 Stainless Steel	316 Stainless Steel	316 Stainless Steel
56	56	Dome Line Tubing <sup>6</sup>	316 Stainless Steel	316 Stainless Steel	316 Stainless Steel
58	58	Bracket <sup>6</sup>	Carbon Steel	316 Stainless Steel	Carbon Steel
60	60	Pipe Plug (Main Base) <sup>6</sup>	Carbon Steel	316 Stainless Steel	Carbon Steel
65	65	Heat Exchanger (Optional)	316 Stainless Steel	316 Stainless Steel	316 Stainless Steel
67	67	Eye Bolt <sup>6</sup>	Carbon Steel	316 Stainless Steel	Carbon Steel

## Notes:

1. Main base assemblies can be provided in special materials. Contact the factory for availability.
2. For S4, the valves are: 3905-3912D - 2.00" (50.8 mm), 3914 - 3916D - 3.00" (76.2 mm) and 3918
3. For S4, the valves are: 3905 - 3912 - 3.00" (76.2 mm) J - T and 3914 - 3916 - 4.00" (101.6 mm) L - P.
4. or B; or SA516 Gr. 70 Carbon Steel (Phosphate Coated).
5. Phosphate Coated.
6. Not Shown.
7. Inlet Size 1.5" (38.1 mm) and 2.0" (50.8 mm), Except 3918 - 2.0" (50.8 mm).
8. Inlet Size 3.0" (76.2 mm) and Above, Plus 3918 - 2.0" (50.8 mm).
9. Disc holder O-ring (12) is not required for steam service.
10. Disc Seal (16) is provided for steam service and when Seat O-ring (18) is Teflon®.

# O-ring Materials

## Soft Goods Selection Chart

3900 Series Valve Soft Goods Selection Chart				
Component	Description	Service		
		Liquid/ Gas <sup>3</sup>	Steam	
		15 to 3750 psig (1.03 to 258.55 barg)	15 to 49 psig (1.03 to 3.38 barg)	50 to 3750 psig (1.03 to 258.55 barg)
Main Valve	Nozzle O-ring	Teflon <sup>®</sup>	Teflon <sup>®</sup>	Teflon <sup>®</sup>
	Cover Plate O-ring	Teflon <sup>®</sup>	Teflon <sup>®</sup>	Teflon <sup>®</sup>
	Guide O-ring	Teflon <sup>®</sup>	Teflon <sup>®</sup>	Teflon <sup>®</sup>
	Disc O-ring	Select <sup>1</sup>	Not Required	Not Required
	O-ring Seat	Select <sup>2</sup>	ethylene / propylene 90	Teflon <sup>®</sup>
	Guide Ring	Teflon <sup>®</sup>	Teflon <sup>®</sup>	Teflon <sup>®</sup>
	Disc Seal or Disc Upper O-ring	Select <sup>1</sup>	ethylene / propylene 90	Teflon <sup>®</sup> energized seal
Pilot Valve	Adjuster Bottom O-ring	Select	ethylene / propylene 90	Teflon <sup>®</sup>
	Adjuster Top O-ring	Select	ethylene / propylene 90	Teflon <sup>®</sup>
	Insert O-ring	Select	ethylene / propylene 90	Teflon <sup>®</sup>
	Base O-ring	Select	ethylene / propylene 90	Teflon <sup>®</sup>
	Piston Spring Seal	Teflon <sup>®</sup>	Teflon <sup>®</sup>	Teflon <sup>®</sup>
	Adjuster Top Spring Seal	Teflon <sup>®</sup>	Teflon <sup>®</sup>	Teflon <sup>®</sup>
	Insert Spring Seal	Teflon <sup>®</sup>	Teflon <sup>®</sup>	Teflon <sup>®</sup>
Modulator	Base O-ring	Select	ethylene / propylene 90	Teflon <sup>®</sup>
	Stop O-ring	Select	ethylene / propylene 90	Teflon <sup>®</sup>
	Seat O-ring	Select	ethylene / propylene 90	Teflon <sup>®</sup>
	Piston Bottom O-ring	Select	ethylene / propylene 90	Teflon <sup>®</sup>
	Piston Bottom Spring Seal	Teflon <sup>®</sup>	Teflon <sup>®</sup>	Teflon <sup>®</sup>
	Piston Top Spring Seal	Teflon <sup>®</sup>	Teflon <sup>®</sup>	Teflon <sup>®</sup>

### Notes:

1. Disc O-ring (12) or Disc Upper O-ring (16) shall be one of the same material and durometer as that selected for the O-ring Seat (18).
2. When Teflon<sup>®</sup> is selected for O-ring Seat (18) the Disc Seal (16) shall be a Teflon<sup>®</sup> energized seal.
3. Select soft good using charts for fluid, pressure and temperature. See selection instructions below.

### Soft Goods selection for liquid service is accomplished as follows:

- A) Material Selection
- The customer must specify the O-ring material.
- B) Main Valve Pressure Limits
- Refer to Table 1 on page 3900.13.
  - Locate the valve orifice and select the durometer for the required set pressure.
- C) Main Valve Temperature Limits
- Refer to Table 2 on page 3900.13.
- D) Pilot Valve Pressure and Temperature Limits
- Locate the material and durometer and verify the temperature limits.
  - If temperature limits are exceeded, repeat Steps A and B.
  - If an O-ring cannot be selected, contact the factory.
  - Refer to Table 3 on page 3900.13.
  - Locate the service and review the pressure and temperature ranges, then select the material and durometer.

# O-ring Materials

## Pressure and Temperature Limits Main Valve and Pilot Valve/Modulator

Table 1: Main Valve Pressure Limits<sup>1</sup>

Inlet Size		Orifice	Durometer										Teflon <sup>®3</sup>							
			50		70-75 <sup>2</sup>				90				-40 to +200°F (-40 to +93.3°C)				201 to 505°F (93.9 to 262.8°C)			
			min.	max.	min.		max.		min.		max.		min.		max.		min.		max.	
in.	mm			psig	barg	psig	barg	psig	barg	psig	barg	psig	barg	psig	barg	psig	barg	psig	barg	
1.00	25.4	D, E, F	N/A	N/A	15	1.03	800.00	55.16	200	13.79	1500	103.42	1000	68.95	3750	258.55	50.00	3.45	3750	258.55
1.50	38.1	D, E, F	N/A	N/A	15	1.03	800.00	55.16	200	13.79	1500	103.42	1000	68.95	3750	258.55	50.00	3.45	3750	258.55
1.50	38.1	G, H	N/A	N/A	15	1.03	780.00	53.78	150	10.34	1500	103.42	1000	68.95	3750	258.55	50.00	3.45	3750	258.55
2.00	50.8	G, H, J	N/A	N/A	15	1.03	780.00	53.78	150	10.34	1500	103.42	1000	68.95	3750	258.55	50.00	3.45	3750	258.55
3.00	76.2	J, K, L	N/A	N/A	15	1.03	580.00	39.99	150	10.34	1500	103.42	1000	68.95	3750	258.55	50.00	3.45	3750	258.55
4.00	101.6	L, M, N, P	N/A	N/A	15	1.03	580.00	39.99	75	5.17	1500	103.42	1000	68.95	3750	258.55	50.00	3.45	3750	258.55
6.00	152.4	Q, R	N/A	N/A	15	1.03	420.00	28.96	60	4.14	600	41.37	600	41.37	1500	103.42	50.00	3.45	1500	103.42
8.00	203.2	T	N/A	N/A	15	1.03	200.00	13.79	30	2.07	300	20.68	300	20.68	1500	103.42	50.00	3.45	1500	103.42
3.00	76.2	Full Bore	N/A	N/A	15	1.03	580.00	39.99	75	5.17	1500	103.42	1000	68.95	1500	103.42	50.00	3.45	1500	103.42
4.00	101.6	Full Bore	N/A	N/A	15	1.03	580.00	39.99	75	5.17	1500	103.42	1000	68.95	1500	103.42	50.00	3.45	1500	103.42
6.00	152.4	Full Bore	N/A	N/A	15	1.03	200.00	13.79	30	2.07	300	20.68	300	20.68	1500	103.42	50.00	3.45	1500	103.42
8.00	203.2	Full Bore	N/A	N/A	15	1.03	200.00	13.79	30	2.07	300	20.68	300	20.68	1500	103.42	50.00	3.45	1500	103.42
10.00	254.0	Full Bore	N/A	N/A	15	1.03	200.00	13.79	30	2.07	300	20.68	300	20.68	750	51.71	50.00	3.45	750	51.71
12.00	304.8	Full Bore	N/A	N/A	15	1.03	200.00	13.79	30	2.07	300	20.68	300	20.68	750	51.71	50.00	3.45	750	51.71

**Notes:**

1. Disc O-ring will be of the same material and durometer as that selected for the Seat O-ring.
2. Maximum set pressure for silicone compounds is half of the maximum value.
3. When Teflon<sup>®</sup> material is selected for the Seat O-ring a Teflon<sup>®</sup> energized seal will be provided for the Disc Seal.

Table 2: Main Valve Temperature Limits

Material	Durometer	Temperature Limits				Material	Durometer	Temperature Limits			
		min.		max.				min.		max.	
		°F	°C	°F	°C			°F	°C	°F	°C
Nitrile (Buna-N) <sup>2</sup>	70	-40	-40.0	250	121.1	Silicone	70	-40	-40.0	437	225.0
	90	-40	-40.0	250	121.1		Teflon <sup>®</sup>	N/A	-40	-40.0	505
Ethylene/Propylene	70	-65	-53.9	212	100.0	Kalrez <sup>®1</sup>	82	-40	-40.0	505	262.8
	90	-40	-40.0	500	260.0		75	-40	-40.0	505	262.8
Fluorocarbon (Viton)	75	-15	-26.1	400	204.4	Chemraz <sup>®1</sup>	91	-35	-37.2	505	262.8
	90	-15	-26.1	400	204.4		75	-20	-28.9	450	232.2
Neoprene	70	-40	-40.0	300	148.9		90	-20	-28.9	450	232.2

**Notes:**

1. Consult factory concerning the use of Kalrez<sup>®</sup> and Chemraz<sup>®</sup>.
2. Standard O-ring Material.

Table 3: Pilot Valve and modulator Pressure/Temperature limits.

Service	O-ring Material <sup>2</sup>	Durometer	Temperature Limit				Pressure Limit			
			min.		max.		min.		max.	
			°F	°C	°F	°C	psig	barg	psig	barg
Liquid/Gas	Nitrile (Buna-N) <sup>3</sup>	70	-40	-40.0	250	121.1	15	1.03	3750	258.55
Liquid/Gas	Fluorocarbon (Viton)	75	-15	-26.1	400	204.4	15	1.03	3750	258.55
Liquid/Gas	Ethylene/Propylene	70	-40	-40.0	400	204.4	15	1.03	3750	258.55
Liquid/Gas	Kalrez <sup>®1</sup>	---	-40	-40.0	400	204.4	15	1.03	3750	258.55
Liquid/Gas	Teflon <sup>®</sup>	N/A	212	100.0	505	262.8	50	3.45	3750	258.55
Steam	Ethylene/Propylene	90	212	100.0	500	260.0	15	1.03	49	3.38
Steam	Teflon <sup>®</sup>	N/A	212	100.0	505	262.8	50	3.45	750	398.9

**Notes:**

1. Consult factory concerning the use of Kalrez<sup>®</sup>.
2. Other materials are on application. Consult factory for availability of other materials.
3. Standard O-ring Material.

# Pop Pilot Product Operation

## Pop Pilot (PV)

### Operating Principles and Performance

GE's MPV (Modular Pilot Valve) Pilot-Operated Safety Relief Valve is offered as both a non-flowing pop pilot and a non-flowing modulating pilot within a single assembly. The unique modular design construction allows vented bonnet and easy field conversion from one configuration to the other. The pilot valve operates by sensing system pressure and using this pressure to control the closing force on the main valve disc. Increasing inlet valve pressure results in increased closing force until the pilot valve opens. Pressure is relieved at a designated set point as process media is allowed to discharge through the main valve. Use of the pop pilot configuration will result in a main valve disc "pop" action from the seated position to 100 percent open. When the overpressure condition is relieved, the main valve disc will reseat due to the increased media pressure directed through the pilot valve to the top of the valve disc (dome).

3900 Series SRV with Pop Pilot

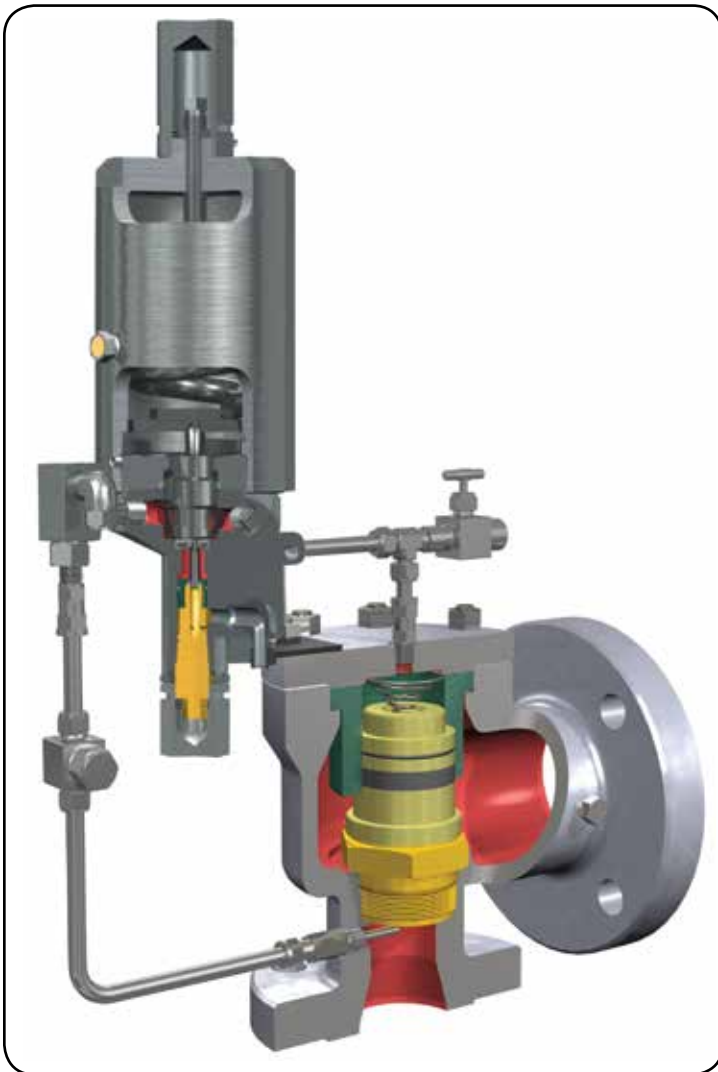

Pop Pilot Performance	
Pilot Tightness	98 percent of set point
Blowdown	2 percent to 5 percent, or 2 psig (0.14 barg) (whichever is greater) depending upon ramp rate.
Longer Blowdown Results from	Fast ramp up increasing the set point or fast ramp down decreasing the reset point.
Shorter Blowdown Results from	Slow ramp up or slow ramp down.
Pilot Tightness after Main Valve Pop	95 percent of set point
Pilot Tightness after Pilot Reseats	98 percent of set point
Vent to Main Valve Outlet if	Back Pressure is constant or no back pressure

Common Characteristics	
Pressure Ranges	
liquid or gas	15 - 3750 psig (1.03 - 258.55 barg)
steam	5 - 750 psig (0.34 - 51.71 barg)
Temperature Ranges	
Compatible for liquid, gas, or steam service	-40 - 505°F (-40 - 262.8°C)

# Pop Pilot Product Operation

## Pop Pilot Operation

PV Valve Closed (Normal Position)

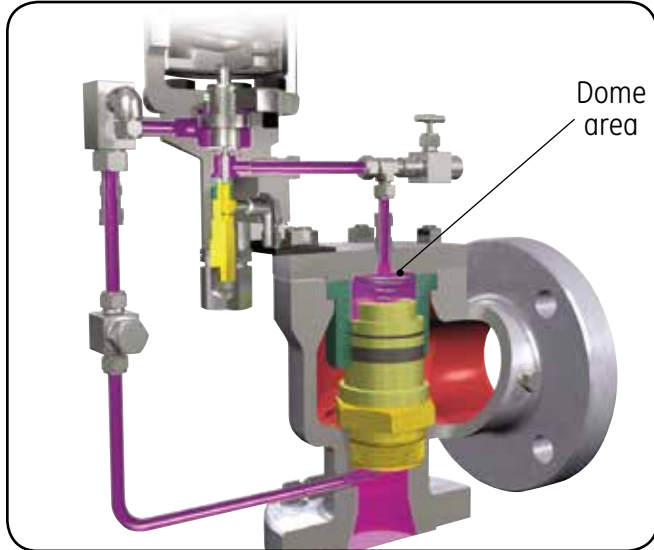

System pressure from the main valve inlet is fed to the dome area by the pilot through interconnecting tubing. This equalizes the pressure on the top of the disc with inlet pressure on the seating surface (bottom) of the disc. Since the area of the top of the disc is larger than the area of the seating surface, the differential area results in a net downward force keeping the main valve tightly closed.

PV Valve Open (Relieving Position)

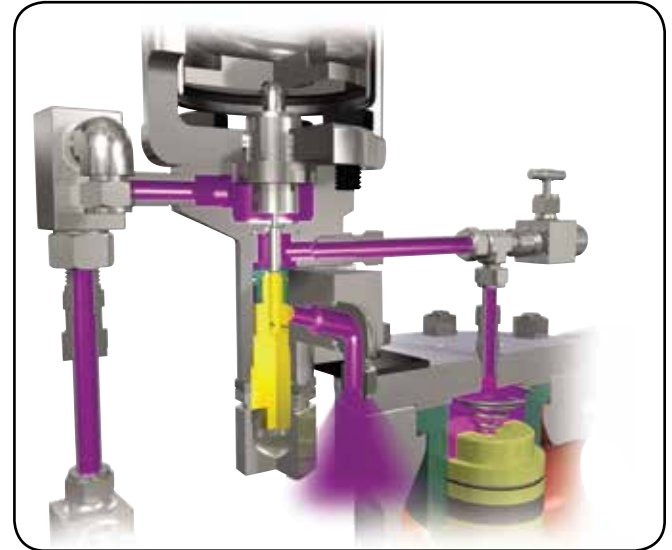

As inlet pressure increases, the pilot piston strokes and seals off the main valve inlet pressure from the dome pressure. The pilot simultaneously opens the vent seal to relieve the dome pressure to atmospheric pressure.

Discharge Through Main Valve

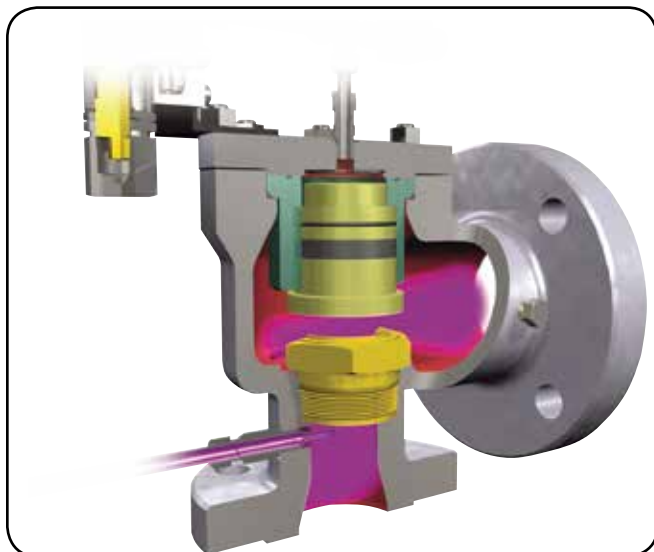

The main valve disc is allowed to lift off the seat as the fluid force overcomes the now removed pressure load above the main valve disc. The valve discharges to relieve system pressure.

Return to Normal Position

When the discharging main valve reduces the inlet pressure to the preset blowdown pressure of the pilot, the pilot piston closes the vent seal. Simultaneously, the inlet seal is reopened in the pilot. The main valve inlet pressure is again allowed to enter the dome above the main valve disc. As the dome pressure equalizes with the inlet pressure, the downward force created by the differential areas of the disc closes the main valve.

# Pop Pilot Materials (PV)

## 3900 Series Type 39PV Pilot

Pop Action, Non-Flowing [For Set Pressures 15 to 3750 psig (1.03 to 258.55 barg)]

3900 Series with 39PV Pop Action



## Description

GE's 39PV pop action non-flowing pilot provides high performance with full lift at set pressure with minimal blowdown. Buna N O-rings and 316 stainless steel construction throughout are standard.

The pilot is non-flowing at full open, improving its capabilities to handle dirty conditions and reduce icing problems. There are two unique features of the 39PV: (1) it can be used on liquid, gas or steam service without any adjustments, and (2) the 39PV pop action pilot may be converted to the 39MV modulating pilot by simply installing

the modulator assembly. This simple, modular design allows for easier maintenance and fewer spare parts.

Set pressures are field adjustable, and testing is easily performed using the standard field test connection. Manual blowdown, sensing line filter, backflow preventer, and remote sensing are available as options



# Pop Pilot Materials (PV)

## 39PV 07/37 Pilot Construction

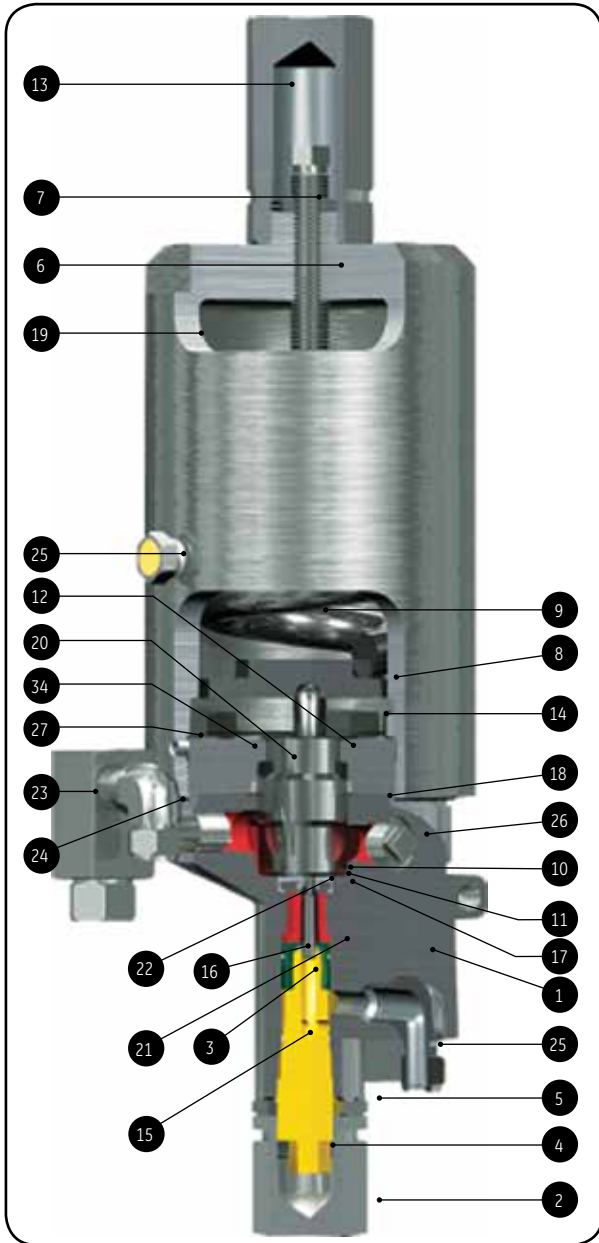

## High Pressure

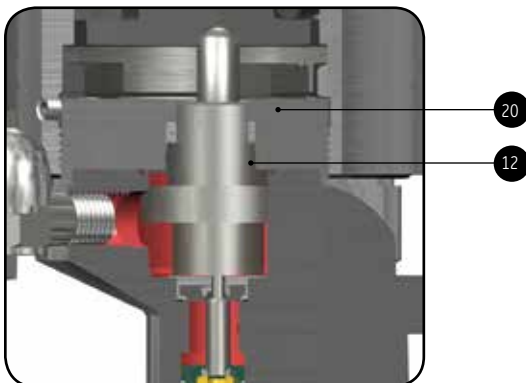

## 39PV 07/37 Pilot Standard Material Variation

Ref. No.	Nomenclature	Material <sup>1</sup>
1	Main Base	ASME SA351 CF8M St. St.
2	Adjuster Cap	316 Stainless Steel
3	Adjuster Top	316 Stainless Steel
4	Adjuster Bottom	316 Stainless Steel
5	Adjuster Lock Nut	316 Stainless Steel
6	Compression Screw	316 Stainless Steel
7	Compression Screw Lock Nut	316 Stainless Steel
8	Spring Washer	316 Stainless Steel
9	Spring	Chrome St. (Phosphate Coated)
10	Insert Top	316 Stainless Steel
11	Insert Bottom	316 Stainless Steel
12	Main Piston	316 Stainless Steel
13	Cap (Compression Screw)	316 Stainless Steel
14	Cap Screw (Top Plate)	ASME SA193 B8M St. St.
15	O-ring (Adjuster Bottom)	Select
16	O-ring (Adjuster Top)	Select
17	O-ring (Insert)	Select
18	O-ring (Top Plate)	Select
19	Bonnet	ASME SA351 CF8M St. St.
20	Spring Seal (Main Piston)	Teflon
21	Spring Seal (Adjuster Top)	Teflon
22	Spring Seal (Insert)	Teflon
23	Field Test Connector	
	Ball	316 Stainless Steel
	Seat O-ring	Select
	Plug O-ring	Select
	Shuttle Base	316 Stainless Steel
	Shuttle Plug	316 Stainless Steel
	Tube Filter	304 Stainless Steel
24	Vent Assembly/Bug Screen (Field Test Connection)	
	Male Elbow	316 Stainless Steel
	Screen	304 Stainless Steel
25	Vent Assembly (Bonnet Vent) <sup>2</sup>	Nickel Steel/Bronze
26	Pipe Plug (Pilot Valve)	304 Stainless Steel
27	Set Screw (Bonnet)	316 Stainless Steel
34	Top Plate	316 Stainless Steel

### Notes:

1. Pilot valves are available in materials other than those shown above. Refer to 2900\_Catalogue for alternate materials of construction.
2. Standard material is a filter plug. For special materials, vent assembly is supplied.

# Modulating Pilot Product Operation

## Modulating Pilot (MV)

### Operating Principles and Performance

GE's MPV (Modular Pilot Valve) Pilot-Operated Safety Relief Valve is also offered as a non-flowing modulating pilot design, using a unique modular configuration that allows for easy field conversion from pop operation to modulating operation. The modulating pilot operation is very similar to the pop pilot operation with the added ability to hold a percentage of system pressure above the main valve disc, producing a modulating action. Increasing the system pressure results in reduced closing force due to venting through the pilot valve. Pressure relief

begins at a designated set point as process media is discharged through the main valve. However, the actual lift of the main valve disc is based on the specific system overpressure condition instead of "popping" instantaneously to the 100 percent open position (as with the pop pilot). This "modulating" action results in improved operating efficiencies through reduced media loss and lower emissions.

3900 Series SRV with Modulating Pilot

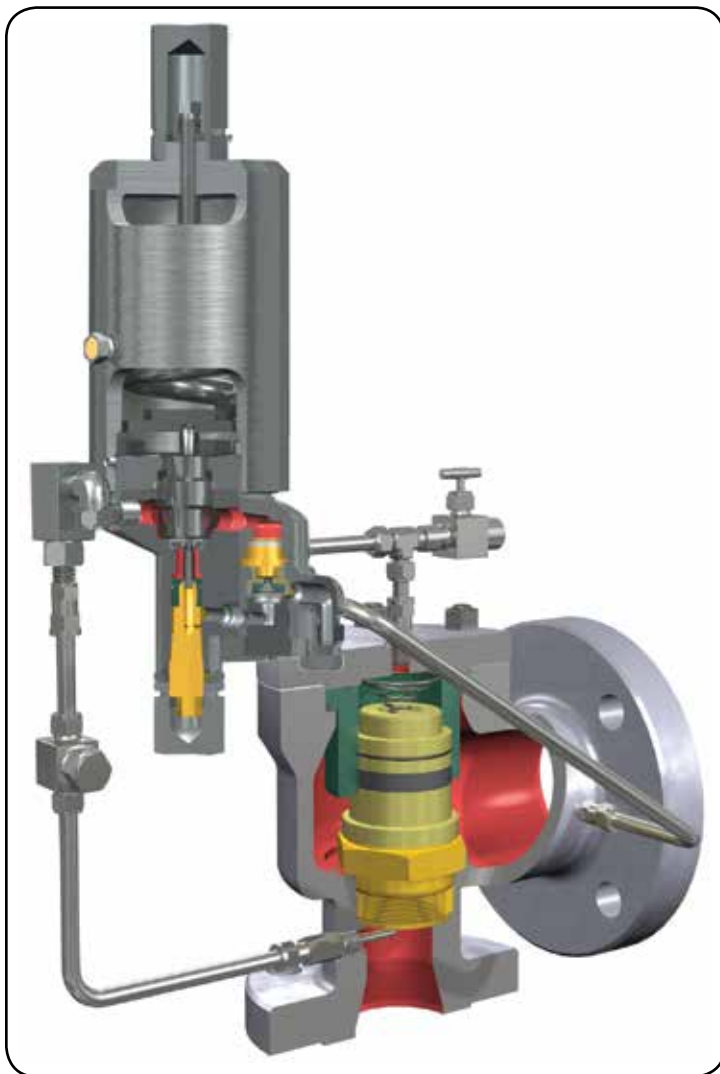

### Modulating Pilot Performance

Pilot Tightness	99 percent of set point
Blowdown	1 percent to 4 percent, or 2 psig (0.14 barg) (whichever is greater) depending upon ramp rate.
Pilot Tightness after Pop	96 percent of set point.
Pilot Tightness after Reseat	99 percent of set point.

#### Notes:

1. Tightness is defined as zero bubbles per minute.

### Common Characteristics

Pressure Ranges	
liquid or gas	15 - 3750 psig (1.03 - 258.55 barg)
steam	15 - 750 psig (1.03 - 51.71 barg)
Temperature Ranges	
Compatible for liquid, gas, or steam service	-40 - 505°F (-40 - 262.8°C)

# Modulating Pilot Product Operation

## Modulating Pilot Operation

MV Valve Closed (Normal Position)

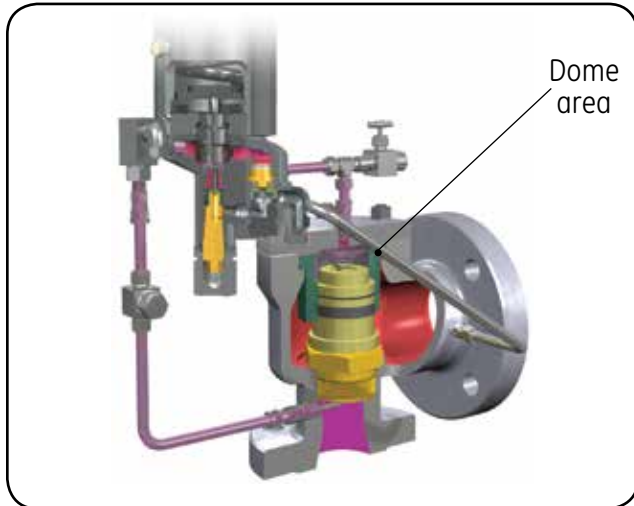

System pressure from the main valve inlet is fed to the dome area by the pilot through interconnecting tubing. This equalizes the pressure on the top of the disc with inlet pressure on the seating surface (bottom) of the disc. Since the area of the top of the disc is larger than the area of the seating surface, the differential area results in a net downward force keeping the main valve tightly closed.

MV Fully Open

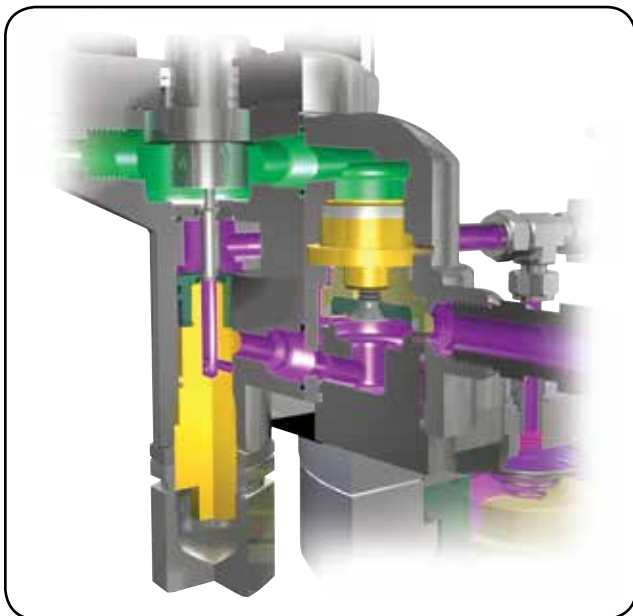

As the inlet pressure increases further, the net upward force on the main valve increases, allowing the main valve to relieve more pressure. The disc obtains full lift (full capacity) within 10 percent of set pressure.

Modulating Position

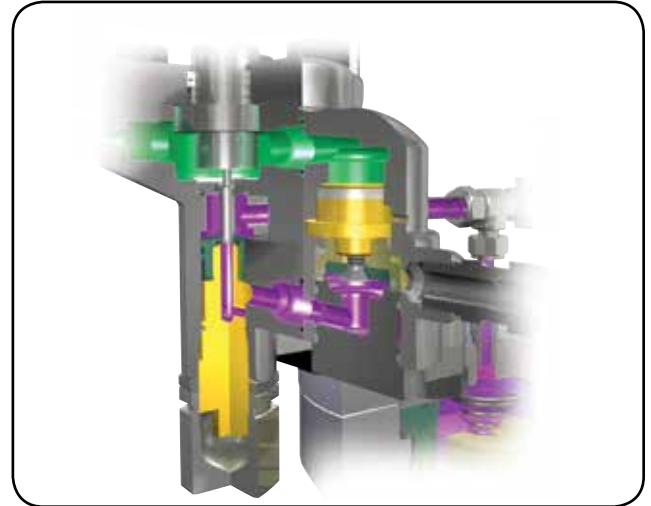

As inlet pressure increases, the pilot piston strokes and seals off the main valve inlet pressure from the dome pressure. The pilot simultaneously opens the vent seal to relieve the dome pressure to the bottom of the modulator piston. The modulator piston has a differential area with the smaller area being on top. The top of this piston always sees the main valve inlet pressure. When the dome pressure is applied to the bottom of the modulator piston, there is a net upward force. This is due to both pressures being equal (at this point), and the lower area is larger than the upper area. The modulator relieves pressure from the dome to the atmosphere until force from the inlet pressure on top of the modulator piston is sufficient to move it to the closed position. A certain amount of pressure remains in the dome. This pressure is controlled by the differential area in the modulator. Since the dome pressure has not been dropped to atmospheric pressure, the main valve only partially opens at the set point. The modulator piston will remain closed until the main valve disc is forced into higher lift by increasing inlet pressure. As this occurs, the modulator piston may relieve further pressure from the dome as necessary to achieve the required main disc lift within 10 percent overpressure.

### Return to Normal Position

When the discharging valve reduces the inlet pressure to the pre-set blowdown pressure of the pilot, the pilot piston closes the vent seal. Simultaneously, the inlet seal is reopened in the pilot. The main valve inlet pressure is again allowed to enter the dome above the main valve disc. As the dome pressure equalizes with the inlet pressure, the downward force created by the differential areas of the disc closes the main valve.

# Modulating Pilot Materials

## 3900 Series Type 39MV 07 Pilot

Modulating Action, Non-Flowing [For Set Pressures 15 to 3750 psig (1.03 to 258.55 barg)]

3900 Series Valve with 39MV Modulating Action



## Description

GE's 39MV Pilot-Operated Safety Relief Valve is a non-flowing modulating pilot valve that provides high performance and stable operation. The 39MV design controls the attached main valve so as to relieve only enough system pressure to control the system upset, thereby minimizing the media lost. This patented technology is the latest advancement in pilot design within the pressure range of 15 psig (1.03 barg) to 3750 psig (258.55 barg) for vapor, liquid and steam service.

The 39MV design is the only non-flowing modulating valve of its kind available with adjustable blowdown.

This unique modulator is a simple addition to the 39PV pop action design. The simplicity of design allows for easier maintenance and for lower spare parts inventory.

# Modulating Pilot Materials

## 39MV 07 Pilot Construction

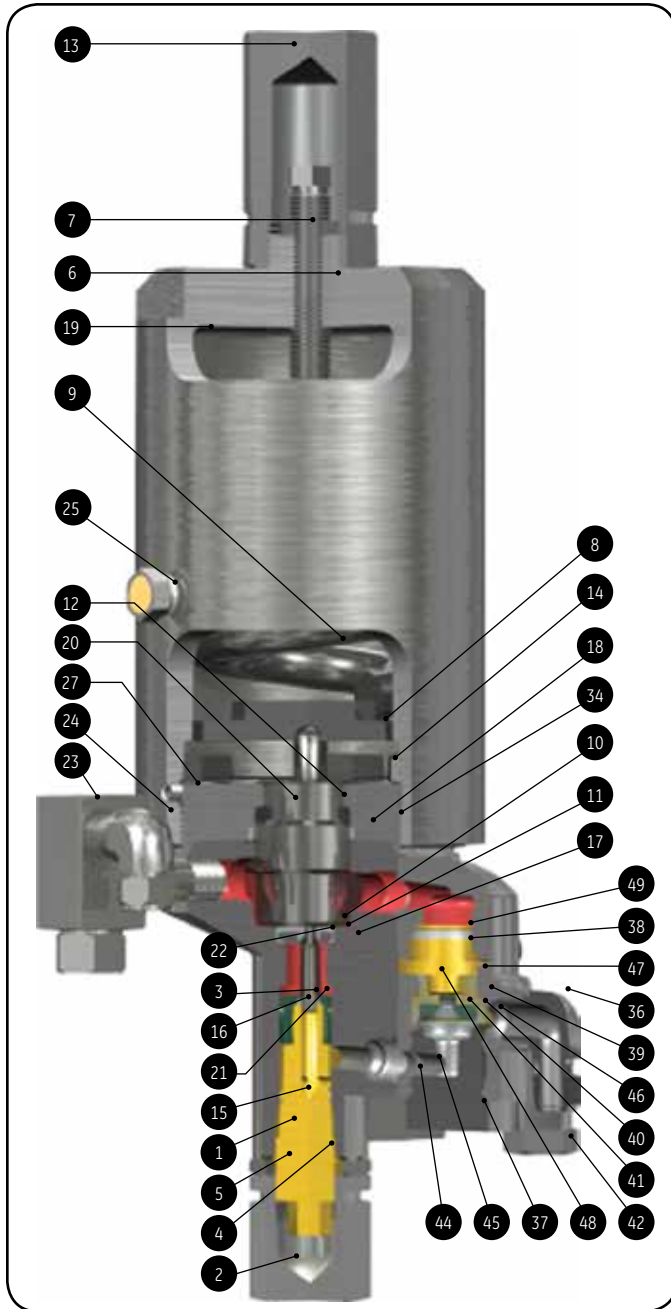

### High Pressure

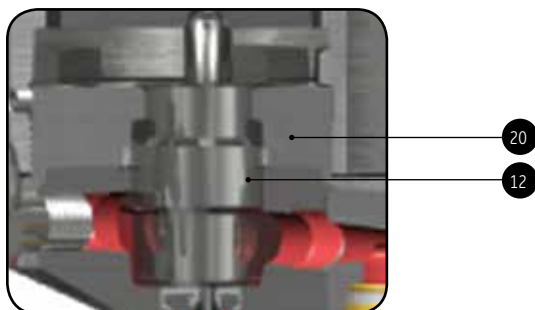

## 39MV 07 Pilot Standard Material Variation

Ref. No.	Nomenclature	Material <sup>1</sup>
1	Main Base	SA351 Grade CF8M St. St.
2	Adjuster Cap	316 Stainless Steel
3	Adjuster Top	316 Stainless Steel
4	Adjuster Bottom	316 Stainless Steel
5	Adjuster Lock Nut	316 Stainless Steel
6	Compression Screw	316 Stainless Steel
7	Compression Screw Lock Nut	316 Stainless Steel
8	Spring Washer	316 Stainless Steel
9	Spring	Chrome St. (Phosphate Coated)
10	Insert Top	316 Stainless Steel
11	Insert Bottom	316 Stainless Steel
12	Main Piston	316 Stainless Steel
13	Cap (Compression Screw)	316 Stainless Steel
14	Cap Screw (Top Plate)	316 Stainless Steel
15	O-ring (Adjuster Bottom)	Select
16	O-ring (Adjuster Top)	Select
17	O-ring (Insert)	Select
18	O-ring (Top Plate)	Select
19	Bonnet	SA351 Grade CF8M St. St.
20	Spring Seal (Main Piston)	Teflon
21	Spring Seal (Adjuster Top)	Teflon
22	Spring Seal (Insert)	Teflon
23	Field Test Connector	
	Ball	316 Stainless Steel
	Seat O-ring	Select
	Plug O-ring	Select
	Shuttle Base	316 Stainless Steel
	Shuttle Plug	316 Stainless Steel
	Tube Filter	304 Stainless Steel
24	Vent Assembly/Bug Screen (Field Test Connection)	
	Male Elbow	316 Stainless Steel
	Screen	304 Stainless Steel
25	Vent Assembly (Bonnet Vent) <sup>2</sup>	Nickel Steel/Bronze
27	Set Screw (Bonnet)	316 Stainless Steel
34	Top Plate	316 Stainless Steel
35	Plug Filter	SA351 Grade CF8M St. St.
36	Modulator Base	SA351 Grade CF8M St. St.
37	Modulator Stop	316 Stainless Steel
38	Modulator Piston Top	316 Stainless Steel
39	Modulator Piston Bottom	316 Stainless Steel
40	O-ring Retainer	316 Stainless Steel
41	Lock Screw (Retainer)	316 Stainless Steel
42	Cap Screw (Modulator)	316 Stainless Steel
43	Socket Head Cap Screw (Mod.)	Select
44	O-ring (Mod. Base)	Select
45	O-ring (Mod. Stop)	Select
46	O-ring (Mod. Seat)	Select
47	O-ring (Mod. Piston Bottom)	Teflon
48	Spring Seal (Piston Bottom)	Teflon
49	Spring Seal (Piston Top)	Teflon

### Notes:

1. Pilot valves are available in materials other than those shown above. Refer to 2900\_Catalogue for alternate materials of construction.
2. Standard material is a filter plug. For special materials, vent assembly is supplied.

# Modulating Pilot Materials

## 3900 Series Type 39MV 22/72 Pilot

39MV 22 Pilot Construction

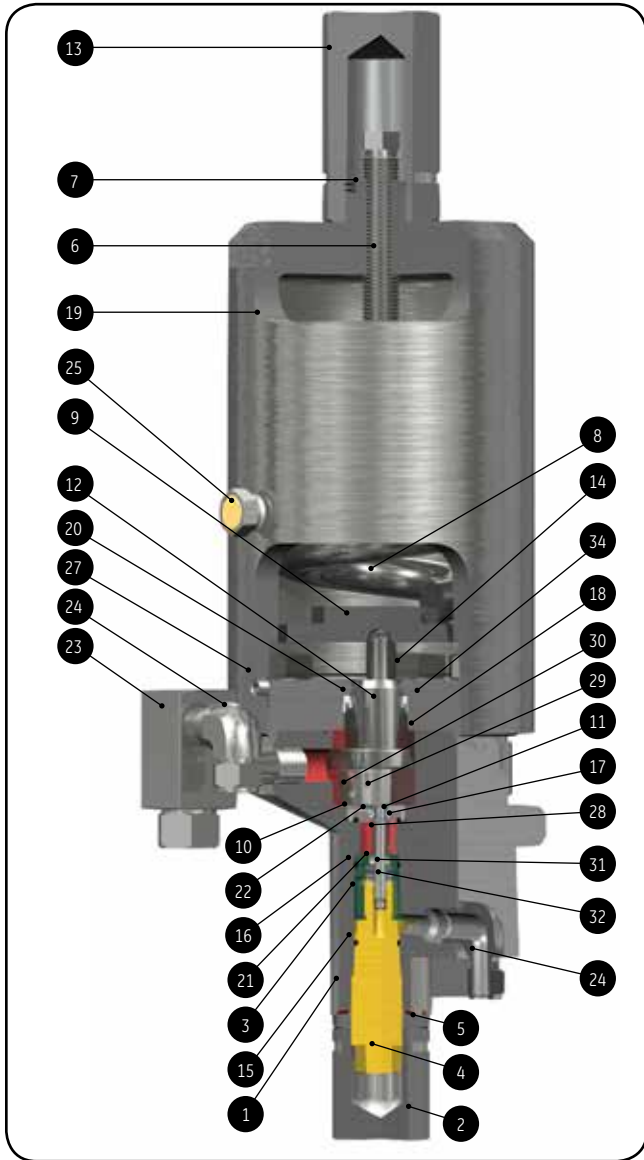

39MV72 Pilot Construction

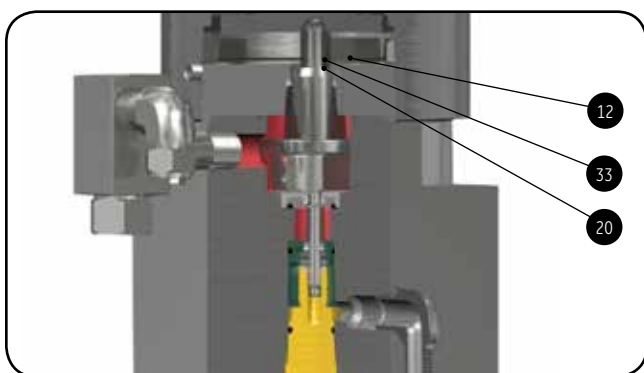

39MV 22/72 Pilot Standard Material Variation

Ref. No.	Nomenclature	Material <sup>1</sup>
1	Main Base	SA351 Grade CF8M St. St.
2	Adjuster Cap	316 Stainless Steel
3	Adjuster Top	316 Stainless Steel
4	Adjuster Bottom	316 Stainless Steel
5	Adjuster Lock Nut	316 Stainless Steel
6	Compression Screw	316 Stainless Steel
7	Compression Screw Lock Nut	316 Stainless Steel
8	Spring Washer	316 Stainless Steel
9	Spring	Chrome St. (Phosphate Coated)
10	Insert Top	316 Stainless Steel
11	Insert Bottom	316 Stainless Steel
12	Main Piston	316 Stainless Steel
13	Cap (Compression Screw)	316 Stainless Steel
14	Cap Screw (Top Plate)	316 Stainless Steel
15	O-ring (Adjuster Bottom)	Select
16	O-ring (Adjuster Top)	Select
17	O-ring (Insert)	Select
18	O-ring (Top Plate)	Select
19	Bonnet	SA351 Grade CF8M St. St.
20	Spring Seal (Main Piston)	Teflon
21	Spring Seal (Adjuster Top)	Teflon
22	Spring Seal (Insert)	Teflon
23	Field Test Connector	
	Ball	316 Stainless Steel
	Seat O-ring	Select
	Plug O-ring	Select
	Shuttle Base	316 Stainless Steel
	Shuttle Plug	316 Stainless Steel
	Tube Filter	304 Stainless Steel
24	Vent Assembly/Bug Screen (Field Test Connection)	
	Male Elbow	316 Stainless Steel
	Screen	304 Stainless Steel
25	Vent Assembly (Bonnet Vent) <sup>2</sup>	Nickel Steel/Bronze
27	Set Screw (Bonnet)	316 Stainless Steel
28	Piston Nose	316 Stainless Steel
29	Piston Retainer Nut	316 Stainless Steel
30	Set Screw (Piston)	Carbon Steel
31	Vent Seal (Adaptor)	316 Stainless Steel
32	Spring Seal (Vent Seal Adaptor)	Teflon
33	Back-up Ring (39MV72 only)	Rulon 55
34	Top Plate	316 Stainless Steel

**Notes:**

1. Pilot valves are available in materials other than those shown above. Refer to 2900\_Catalogue for alternate materials of construction.
2. Standard material is a filter plug. For special materials, vent assembly is supplied.

# Pilot Design Options

## Options and Accessories

Option	Page	Option	Page
Manual Blowdown .....	23	Pressure Differential Switch .....	24
Field Test Connection.....	23	Remote Pilot Mounting .....	24
Filters (Sensing Line, High Capacity and Dual).....	23	Dual Pilots.....	24
Backflow Preventer .....	23	Remote Sensing .....	24
Pilot Valve Tester .....	24	Dirty Service .....	25

### Manual Blowdown Valve

An optional manual blowdown valve is available for relieving the pilot-operated safety relief valve. Consult the factory for applications requiring a pneumatic or electrical solenoid blowdown valve, which may be connected to a distant location, such as an operator station, for remote actuation. The blowdown valve is ported directly to the main dome area, so that the media in the dome is vented when the blowdown valve is actuated, thus allowing the main valve to open.

For all applications on air, water over 140°F (60°C), or steam service, ASME Section VIII - Division 1 requires each pressure relief valve to have a lifting device such as a blowdown valve or a means of connecting or applying pressure to the pilot to verify that the moving parts essential to good operation are free to move. (Reference UG 136(a)(3).)

The lifting lever or blowdown valve may be omitted under Code Case 2203. All orders for pressure relief valves without levers or blowdown valves for steam, air and water over 140°F (60°C) must state specifically that the valves are being purchased per Code Case 2203. The purchaser is responsible for obtaining jurisdictional authorization for use of Code Case 2203.

### Field Test Connection

A 1/4" FNPT field test connection is standard on all pilot valve types. This allows the stroking of the valve with an auxiliary media (e.g., air or nitrogen). An internal check valve is present in the field test connection isolating the inlet media from the test media, and at the same time, allowing the valve to open normally in the event of a system over-pressurization during a field test.

### Filters

Filter options are available for dirty applications. These filters are installed in the pilot inlet sensing line.

For the 39PV and 39MV, an optional sensing line filter is available. This filter has a 316 stainless steel body, Teflon® seals, and a 40-50 micron stainless steel filter element. This filter is standard for steam service.

Other high capacity filter options include: (1) a carbon steel cadmium coated filter body with a 35 micron stainless steel element, (2) a stainless steel filter body, and (3) an entirely stainless steel filter arrangement. The O-ring in the filters for steam service will be Teflon®. These filters may be equipped with a manually operated needle valve which allows for purging the filtered material while the valve is in operation.

All filter elements are stainless steel, and all filters, including carbon steel, conform to NACE Standard MR0175.

A dual filter arrangement is available for applications in which the customer is unsure of the filter maintenance requirements. In these cases, a preventive maintenance program may be developed by monitoring the filters without taking the valve off line.

### Backflow Preventer

When the pilot-operated safety relief valve is not vented directly to the atmosphere, it is possible to build up back pressure in the discharge line. This is typical in situations where several valves manifold into a common discharge header. Should the discharge line pressure exceed the valve inlet pressure, it could cause the piston to lift and allow reverse flow through the main valve. This can be eliminated through the use of the Backflow Preventer.

# Pilot Design Options

## Pilot Valve Tester

The pilot valve test indicator is available for the modulating and pop action pilot valves. The valve test indicator measures the set pressure of the pilot, while maintaining pressure on the main valve dome area; thereby, allowing only the pilot to actuate. The system shown below is available for remote or local testing.

Pilot Valve Tester

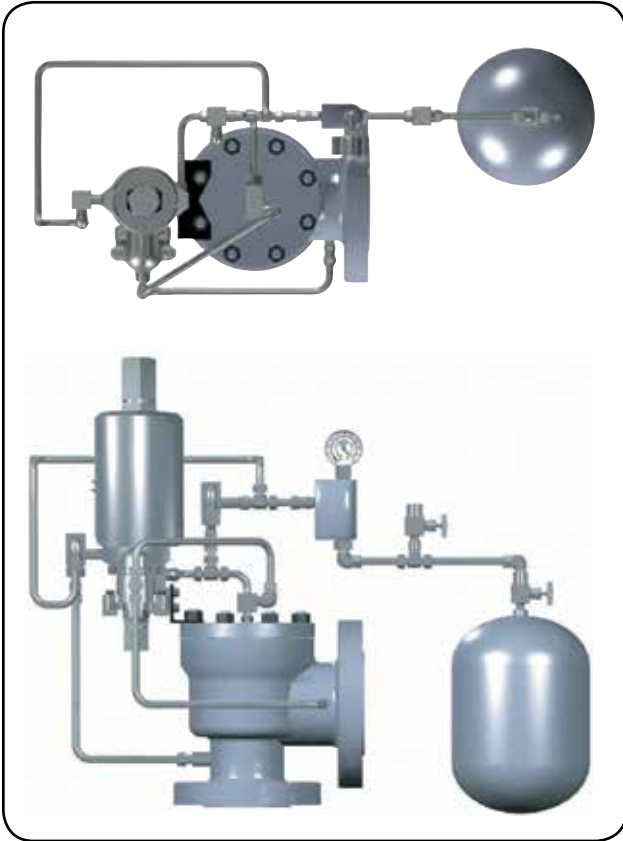

## Pressure Differential Switch

**Electrical:** A pressure differential switch is available that may be wired to an operator station or some other remote location. The switch will provide a signal that indicates when the main valve is opening. The standard pressure differential switch is a single pole, double throw, rated at 5 amps and 30 volts DC with a NEMA 4 enclosure. (For other configurations, consult the factory.)

**Pneumatic:** For applications that do not permit an electrical differential switch, an option is available to provide pneumatic signal to indicate when the main valve opens.

## Remote Pilot Mounting

The 39PV and 39MV pilots can be mounted separately from the main valve. Remote pilot mounting will allow heating or cooling the pilot in case ambient conditions are outside the scope of the pilot. It will also enable the user to group several pilots together for control of ambient conditions in a smaller space. This also promotes easier maintenance.

## Dual Pilots

A dual pilot arrangement is available for applications in which the pilot valve's O-rings require monitoring and/or maintenance more frequently than the main valve. In this installation, the pilot valves may be alternated for maintenance without bringing the system down.

**Note:**

For all option and accessory material variations, contact the factory.

## Remote Sensing

The pilot valve inlet may be piped to a location remote from the main valve. In this application, the customer may pipe the inlet sensing line to some location other than where the main valve is located and where the pressure will be relieved (for tubing size and maximum length, consult factory for recommendations).



# Pilot Design Options

## Dirty Service Option

Severe dirty service, precipitation and viscous fluid problems can be solved using the dirty service option offered on the 3900 Series POSRV. A dirty service option can be added to the standard pilot valve. The kit contains a 316 SS chamber, an isolation seal and an extended pilot piston. The module is positioned at the top of the pilot valve body and below the pilot valve yoke. Crucial valve components such as the modulator, dome assembly, vent, and inlet seals never come in contact with the dirty system media. The process media pressure still controls the set pressure and blowdown of the POSRV.

For applications requiring the main valve to relieve the dirty fluid, an alternate clean media supply is piped to the pilot. The alternate clean media must be set at the same pressure as the set pressure of the pilot valve, but cannot exceed 3750 psig (258.55 barg), which is the design limit of the pilot valve. In the event that the alternate clean media supply is lost, the main valve will fail in the open position.

For applications requiring the main valve to relieve clean fluid upstream of the dirty process in order to maintain the dirty process pressure at safe levels, the dirty process pressure is supplied to the dirty service module. The sensing line from the main valve and the connection to the main valve dome is connected to the pilot in the normal manner. The pilot is set to operate at the design pressure of the dirty process. When the dirty process pressure reaches the set to open pressure of the pilot, the pilot is stroked by the increase in the dirty process pressure and the pilot performs the block and

bleed operations to effect opening of the main valve. When the dirty process pressure reaches the set to close pressure of the pilot, the pilot is stroked by the reduction in the dirty process pressure and the pilot performs the block and bleed operations to bring about the closing of the main valve.

The dirty service module is a closed chamber. The flow of dirty process media to the pilot valve is only that volume required to stroke the pilot in response to increasing dirty process pressure. The limited volume of flowing dirty media entering the pilot makes plugging of the module an unlikely possibility. However, if plugging of the module is a concern, the module can be filled with a compatible clean liquid and a siphon tube can be fitted in the connection line between the pilot module and the dirty process.

The dirty service option can provide cost savings in material selection for corrosive service. It is possible that only the material of construction for the dirty service option will need to be upgraded. The remaining parts in contact with clean media can be of standard construction materials.

**Note:**

For special material options on the dirty service option consult the factory.

MPV Dirty Service Pilot

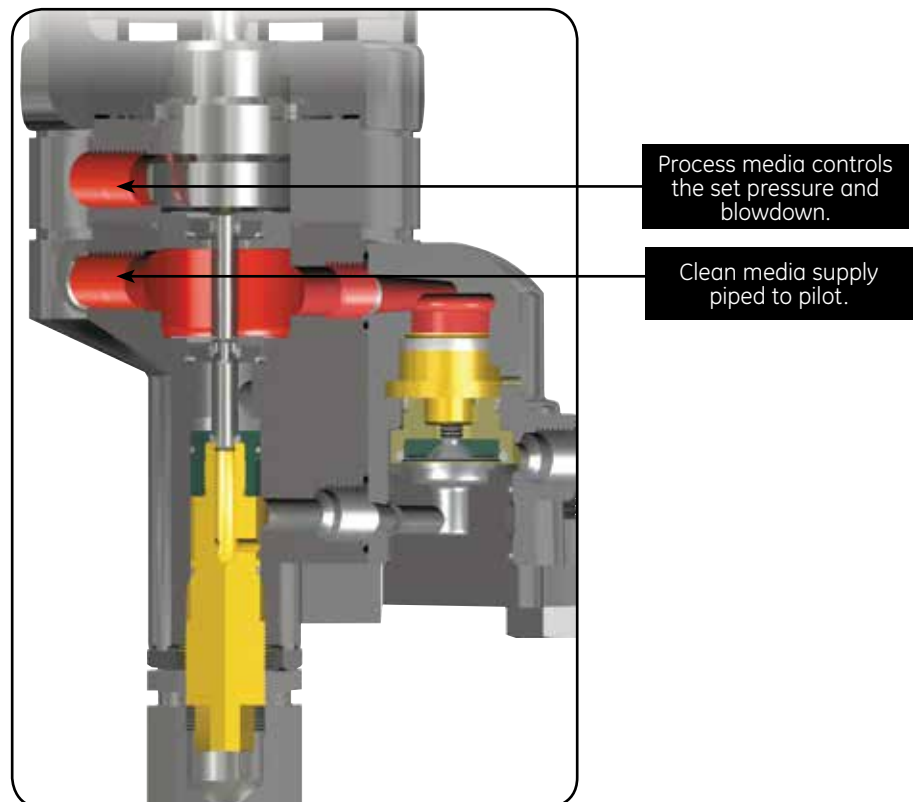

# Piping Configurations

## Alternate Piping Arrangements

### Main Valve

39PV with Pilot Valve Vented to Atmosphere	Single Outlet	Double Outlet
Standard Field Test Connection .....	27	30
Manual Blowdown .....	27	30
Pilot Supply Filter .....	28	31
Backflow Preventer .....	28	31
Manual Blowdown and Pilot Supply Filter .....	29	32
Backflow Preventer, Manual Blowdown and Pilot Supply Filter .....	29	32

39MV with Pilot Valve Vented to Atmosphere		
Standard Field Test Connection .....	33	36
Manual Blowdown .....	33	36
Pilot Supply Filter .....	34	37
Backflow Preventer .....	34	37
Manual Blowdown and Pilot Supply Filter .....	35	38
Backflow Preventer, Manual Blowdown and Pilot Supply Filter .....	35	38

39PV with Pilot Valve Vented to Body Bowl		
Standard Field Test Connection .....	39	42
Manual Blowdown .....	39	42
Pilot Supply Filter .....	40	43
Backflow Preventer .....	40	43
Manual Blowdown and Pilot Supply Filter .....	41	44
Backflow Preventer, Manual Blowdown and Pilot Supply Filter .....	41	44

39MV with Pilot Valve Vented to Body Bowl		
Standard Field Test Connection .....	45	48
Manual Blowdown .....	45	48
Pilot Supply Filter .....	46	49
Backflow Preventer .....	46	49
Manual Blowdown and Pilot Supply Filter .....	47	50
Backflow Preventer, Manual Blowdown and Pilot Supply Filter .....	47	50

# Piping Configurations

## Alternate Piping Arrangements

3900 Series Type 39PV Pilot with Single Outlet (Pilot Vented to Atmosphere)

Pilot Valve with Standard Field Test Connection (Standard For All Media Applications)

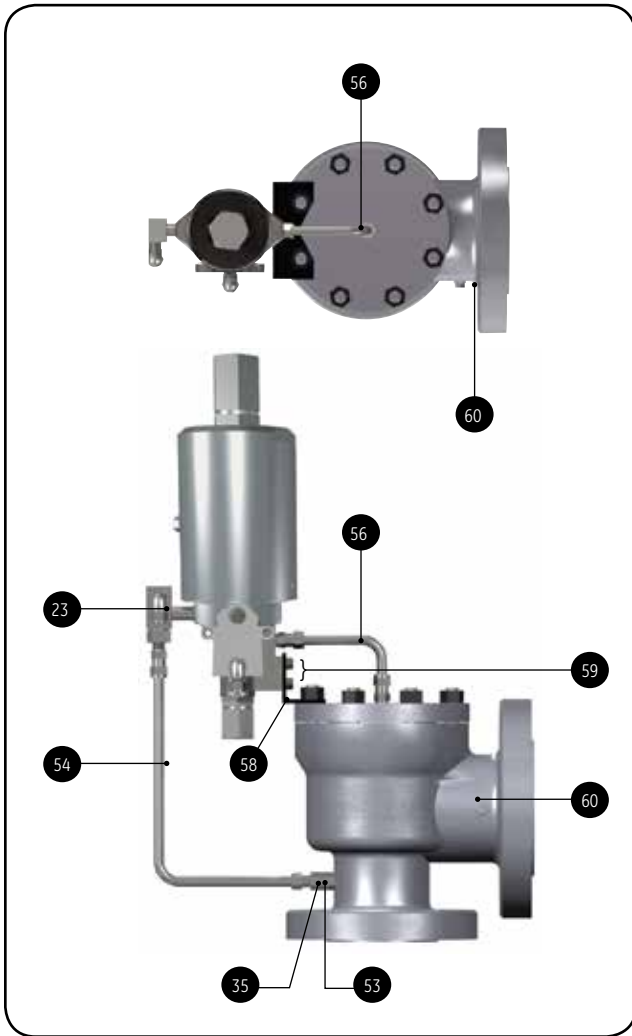

Pilot Valve with Manual Blow down (Optional For All Media Applications)

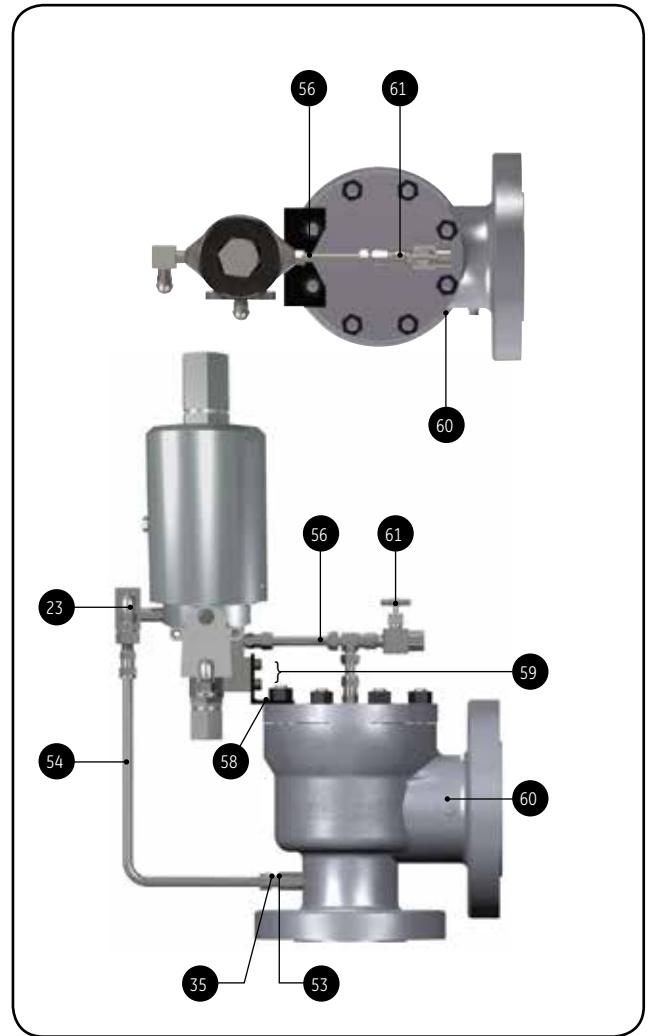

Pilot Valve with Standard Field Test Connection  
(Standard For All Media Applications)

Ref. No.	Part	Material
23	Field Test Connection	316 Stainless Steel
35	Plug Filter	316 Stainless Steel
53	Sensing Tube	316 Stainless Steel
54	Sensing Line	316 Stainless Steel
56	Dome Line	316 Stainless Steel
58	Bracket	Carbon Steel
59	Bracket Cap Screw	316 Stainless Steel
60	Pipe Plug	Carbon Steel

Pilot Valve with Manual Blow down  
(Optional For All Media Applications)

Ref. No.	Part	Material
23	Field Test Connection	316 Stainless Steel
35	Plug Filter	316 Stainless Steel
53	Sensing Tube	316 Stainless Steel
54	Sensing Line	316 Stainless Steel
56	Dome Line	316 Stainless Steel
58	Bracket	Carbon Steel
59	Bracket Cap Screw	316 Stainless Steel
60	Pipe Plug	Carbon Steel
61	Needle Valve (Manual Blowdown)	316 Stainless Steel

# Piping Configurations

## 39MPV Series Type 39PV Pilot with Single Outlet

(Pilot Vented to Atmosphere)

Pilot Valve with Pilot Supply Filter  
(Optional For All Media Applications)

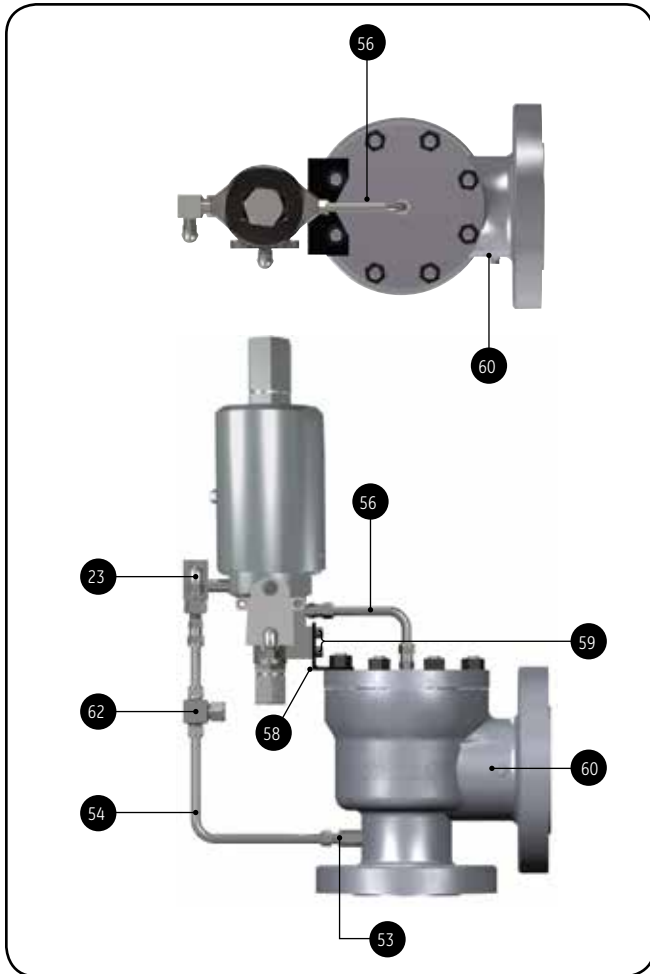

Pilot Valve with Backflow Preventer  
(Optional For Liquid and Gas Applications)

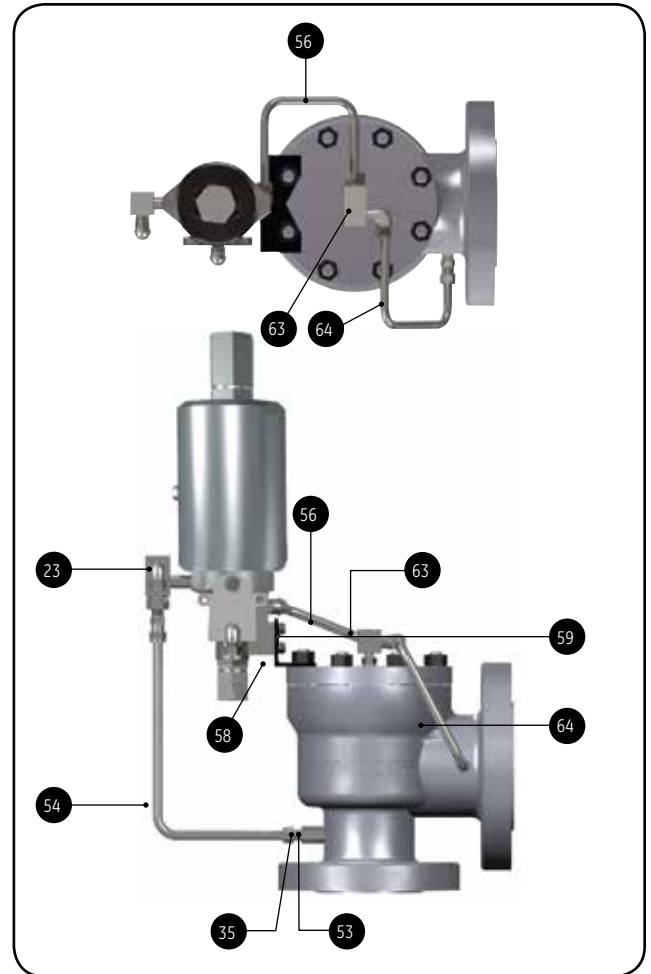

Pilot Valve with Pilot Supply Filter (Optional For All Media Applications)		
Ref. No.	Part	Material
23	Field Test Connection	316 Stainless Steel
53	Sensing Tube	316 Stainless Steel
54	Sensing Line	316 Stainless Steel
56	Dome Line	316 Stainless Steel
58	Bracket	Carbon Steel
59	Bracket Cap Screw	316 Stainless Steel
60	Pipe Plug	Carbon Steel
62	Pilot Supply Filter	316 Stainless Steel

Pilot Valve with Backflow Preventer (Optional For Liquid and Gas Applications)		
Ref. No.	Part	Material
23	Field Test Connection	316 Stainless Steel
35	Plug Filter	316 Stainless Steel
53	Sensing Tube	316 Stainless Steel
54	Sensing Line	316 Stainless Steel
56	Dome Line	316 Stainless Steel
58	Bracket	Carbon Steel
59	Bracket Cap Screw	316 Stainless Steel
63	Backflow Preventer	316 Stainless Steel
64	Backflow Preventer Line	316 Stainless Steel

# Piping Configurations

## 39MPV Series Type 39PV Pilot with Single Outlet

(Pilot Vented to Atmosphere)

Pilot Valve with Manual Blowdown and Pilot Supply Filter (Standard for Steam Applications)  
(Optional for Liquid and Gas Applications)

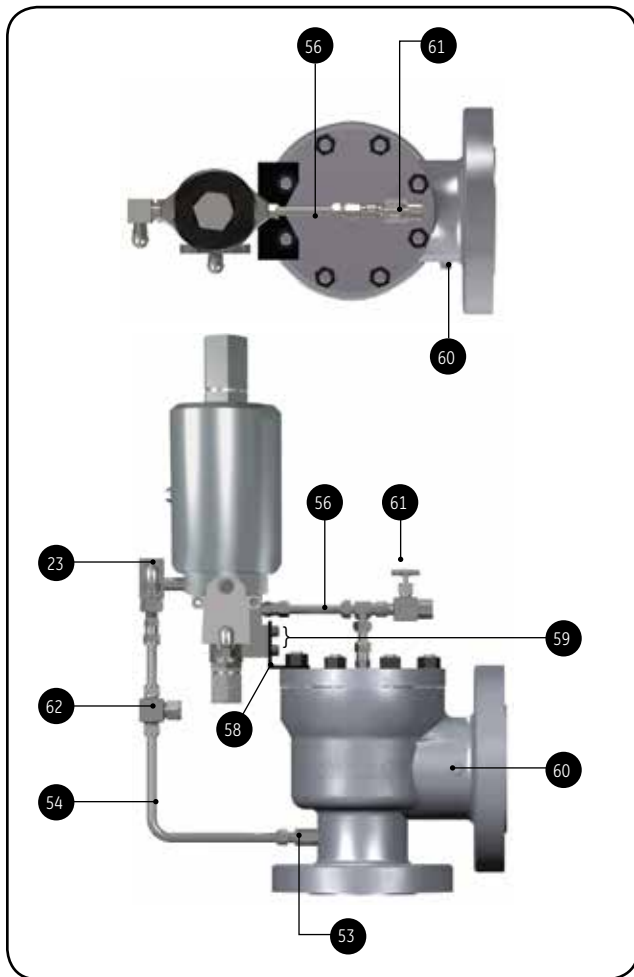

Pilot Valve with Manual Blowdown, Pilot Supply Filter and Backflow Preventer (Optional For Steam Applications)

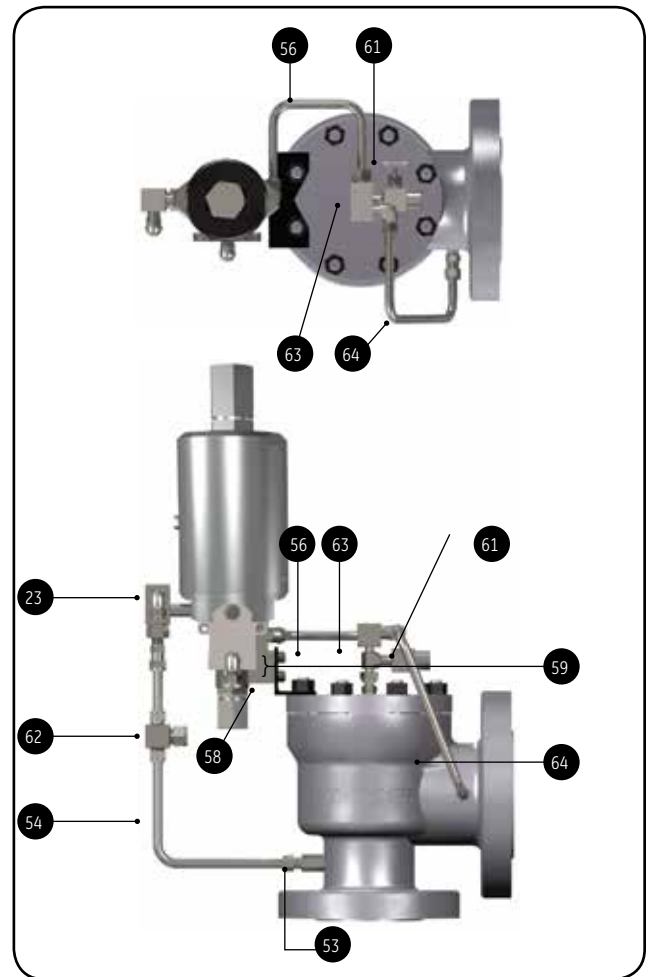

Pilot Valve with Manual Blowdown and Pilot Supply Filter  
(Standard for Steam Applications)  
(Optional for Liquid and Gas Applications)

Ref. No.	Part	Material
23	Field Test Connection	316 Stainless Steel
53	Sensing Tube	316 Stainless Steel
54	Sensing Line	316 Stainless Steel
56	Dome Line	316 Stainless Steel
58	Bracket	Carbon Steel
59	Bracket Cap Screw	316 Stainless Steel
60	Pipe Plug	Carbon Steel
61	Needle Valve (Manual Blowdown)	316 Stainless Steel
62	Pilot Supply Filter	316 Stainless Steel

Pilot Valve with Manual Blowdown,  
Pilot Supply Filter and Backflow Preventer  
(Optional For Steam Applications)

Ref. No.	Part	Material
23	Field Test Connection	316 Stainless Steel
53	Sensing Tube	316 Stainless Steel
54	Sensing Line	316 Stainless Steel
56	Dome Line	316 Stainless Steel
58	Bracket	Carbon Steel
59	Bracket Cap Screw	316 Stainless Steel
61	Needle Valve (Manual Blowdown)	316 Stainless Steel
62	Pilot Supply Filter	316 Stainless Steel
63	Backflow Preventer	316 Stainless Steel
64	Backflow Preventer Line	316 Stainless Steel

# Piping Configurations

## 39MPV Series Type 39PV Pilot with Double Outlet

(Pilot Vented to Atmosphere)

Pilot Valve with Field Test Connection  
(Standard For All Media Applications)

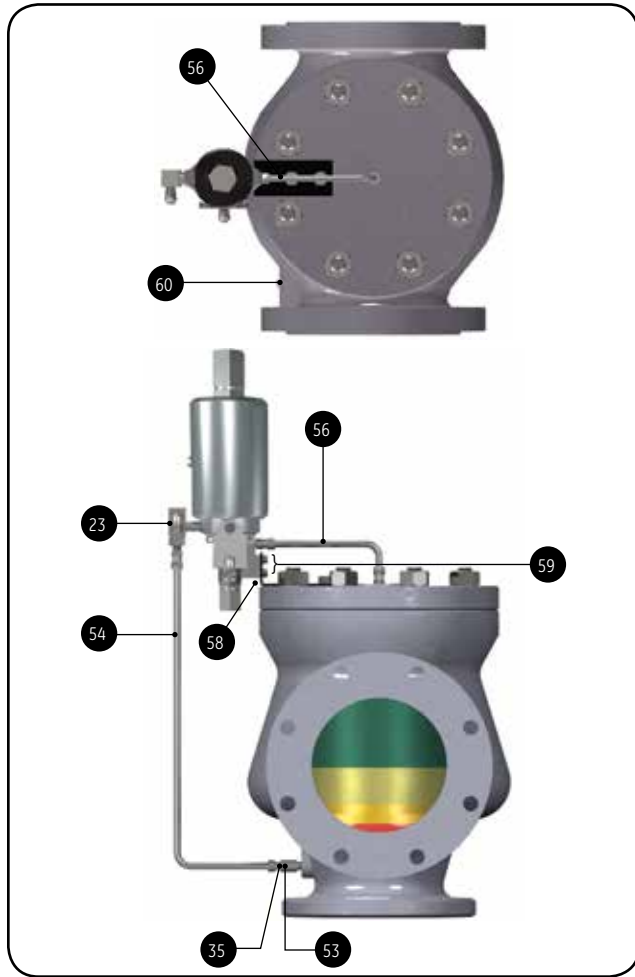

Pilot Valve with Manual Blowdown  
(Optional For Liquid and Gas Applications)

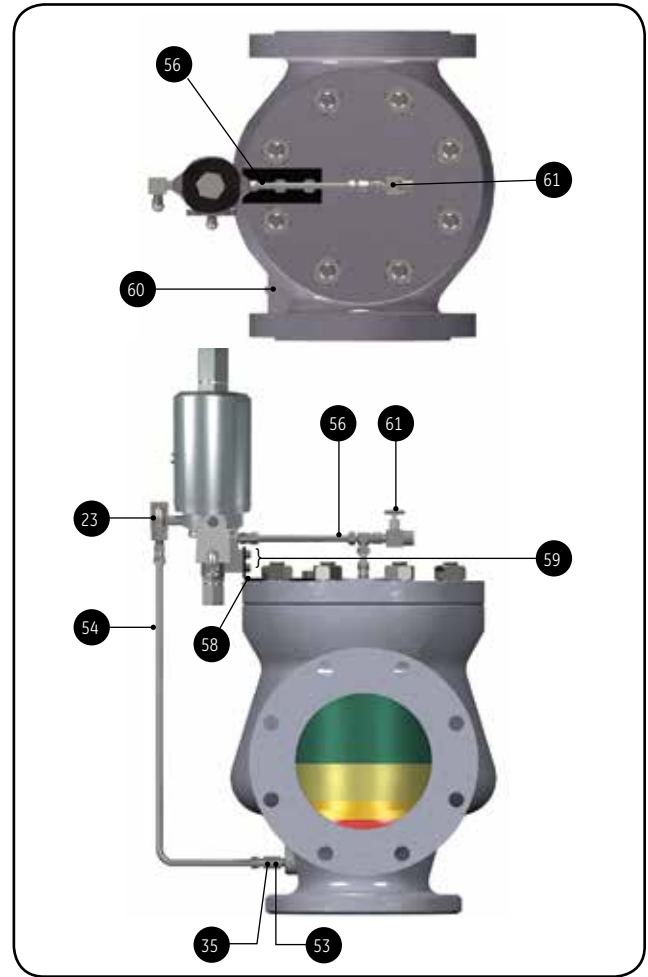

Pilot Valve with Field Test Connection  
(Standard For All Media Applications)

Ref. No.	Part	Material
23	Field Test Connection	316 Stainless Steel
35	Plug Filter	316 Stainless Steel
53	Sensing Tube	316 Stainless Steel
54	Sensing Line	316 Stainless Steel
56	Dome Line	316 Stainless Steel
58	Bracket	Carbon Steel
59	Bracket Cap Screw	316 Stainless Steel
60	Pipe Plug	Carbon Steel

Pilot Valve with Manual Blowdown  
(Optional For Liquid and Gas Applications)

Ref. No.	Part	Material
23	Field Test Connection	316 Stainless Steel
35	Plug Filter	316 Stainless Steel
53	Sensing Tube	316 Stainless Steel
54	Sensing Line	316 Stainless Steel
56	Dome Line	316 Stainless Steel
58	Bracket	Carbon Steel
59	Bracket Cap Screw	316 Stainless Steel
60	Pipe Plug	Carbon Steel
61	Needle Valve (Manual Blowdown)	316 Stainless Steel

# Piping Configurations

## 39MPV Series Type 39PV Pilot with Double Outlet

(Pilot Vented to Atmosphere)

Pilot Valve with Pilot Supply Filter  
(Optional For All Media Applications)

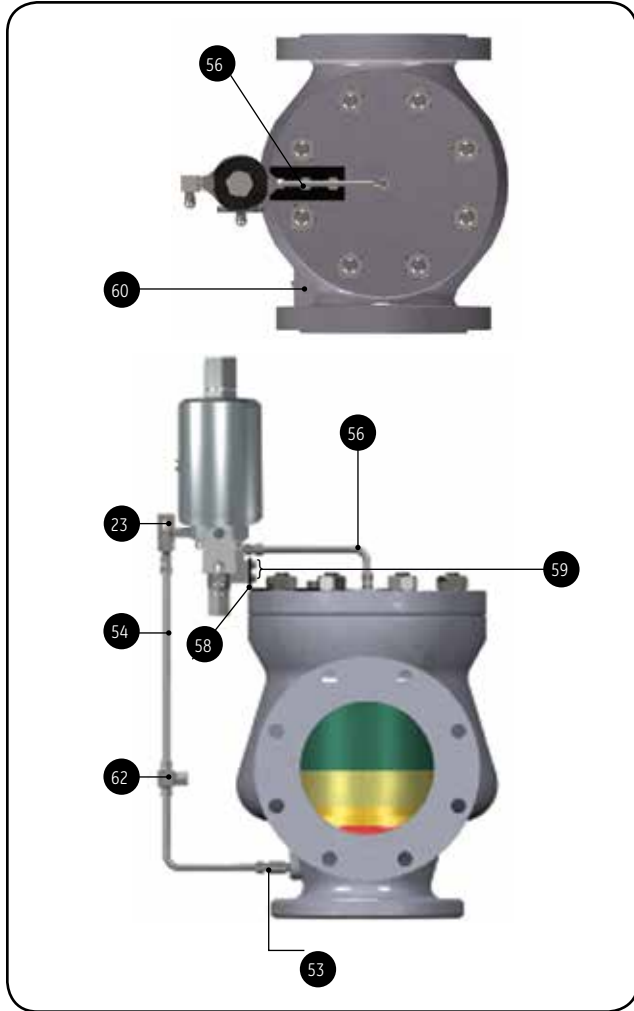

Pilot Valve with Backflow Preventer  
(Optional For Liquid and Gas Applications)

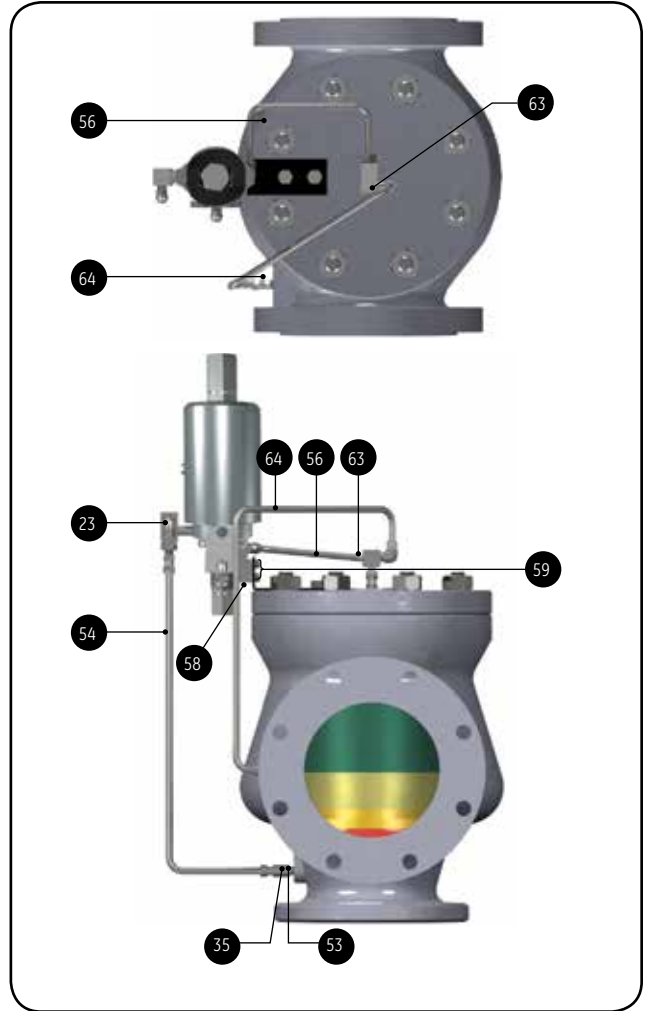

Pilot Valve with Pilot Supply Filter  
(Optional For All Media Applications)

Ref. No.	Part	Material
23	Field Test Connection	316 Stainless Steel
53	Sensing Tube	316 Stainless Steel
54	Sensing Line	316 Stainless Steel
56	Dome Line	316 Stainless Steel
58	Bracket	Carbon Steel
59	Bracket Cap Screw	316 Stainless Steel
60	Pipe Plug	Carbon Steel
62	Pilot Supply Filter	316 Stainless Steel

Pilot Valve with Backflow Preventer  
(Optional For Liquid and Gas Applications)

Ref. No.	Part	Material
23	Field Test Connection	316 Stainless Steel
35	Plug Filter	316 Stainless Steel
53	Sensing Tube	316 Stainless Steel
54	Sensing Line	316 Stainless Steel
56	Dome Line	316 Stainless Steel
58	Bracket	Carbon Steel
59	Bracket Cap Screw	316 Stainless Steel
63	Backflow Preventer	316 Stainless Steel
64	Backflow Preventer Line	316 Stainless Steel

# Piping Configurations

## 39MPV Series Type 39PV Pilot with Double Outlet

(Pilot Vented to Atmosphere)

Pilot Valve with Manual Blowdown and Pilot Supply Filter (Standard for Steam Applications) (Optional for Liquid and Gas Applications)

Pilot Valve with Manual Blowdown, Pilot Supply Filter and Backflow Preventer (Optional For Steam Applications)

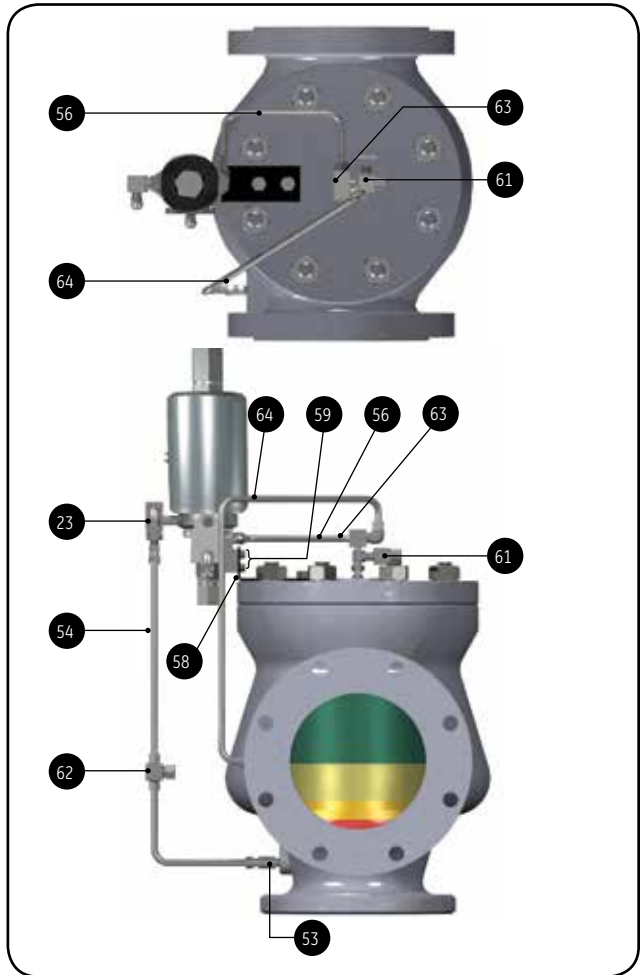
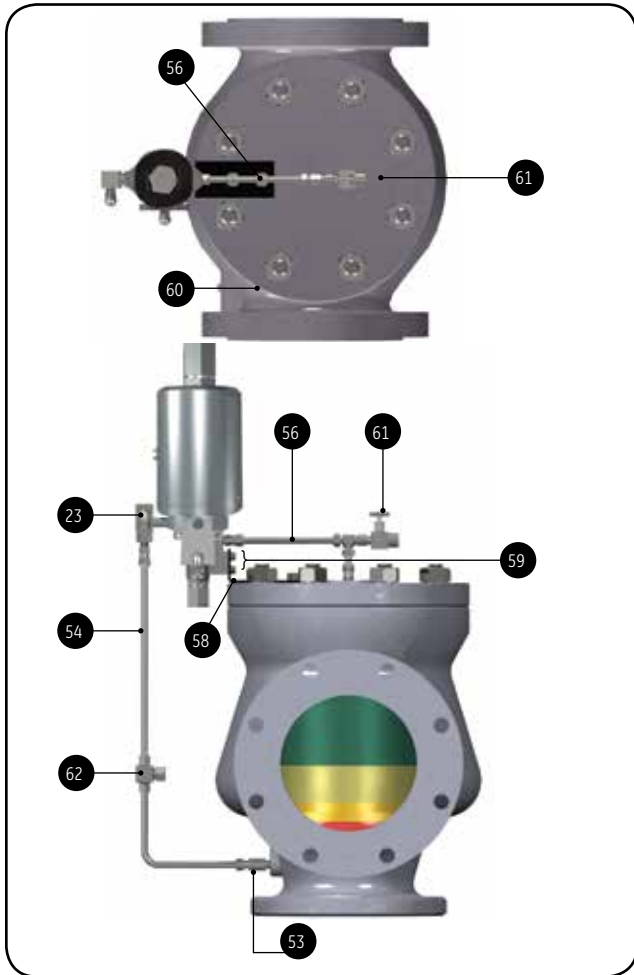

Pilot Valve with Manual Blowdown and Pilot Supply Filter (Standard for Steam Applications) (Optional for Liquid and Gas Applications)

Ref. No.	Part	Material
23	Field Test Connection	316 Stainless Steel
53	Sensing Tube	316 Stainless Steel
54	Sensing Line	316 Stainless Steel
56	Dome Line	316 Stainless Steel
58	Bracket	Carbon Steel
59	Bracket Cap Screw	316 Stainless Steel
60	Pipe Plug	Carbon Steel
61	Needle Valve (Manual Blowdown)	316 Stainless Steel
62	Pilot Supply Filter	316 Stainless Steel

Pilot Valve with Manual Blowdown, Pilot Supply Filter and Backflow Preventer (Optional For Steam Applications)

Ref. No.	Part	Material
23	Field Test Connection	316 Stainless Steel
53	Sensing Tube	316 Stainless Steel
54	Sensing Line	316 Stainless Steel
56	Dome Line	316 Stainless Steel
58	Bracket	Carbon Steel
59	Bracket Cap Screw	316 Stainless Steel
61	Needle Valve (Manual Blowdown)	316 Stainless Steel
62	Pilot Supply Filter	316 Stainless Steel
63	Backflow Preventer	316 Stainless Steel
64	Backflow Preventer Line	316 Stainless Steel



# Piping Configurations

## 39MPV Series Type 39MV Pilot with Single Outlet

(Pilot Vented to Atmosphere)

Pilot Valve with Standard Field Test Connection  
(Standard for All Media Applications)

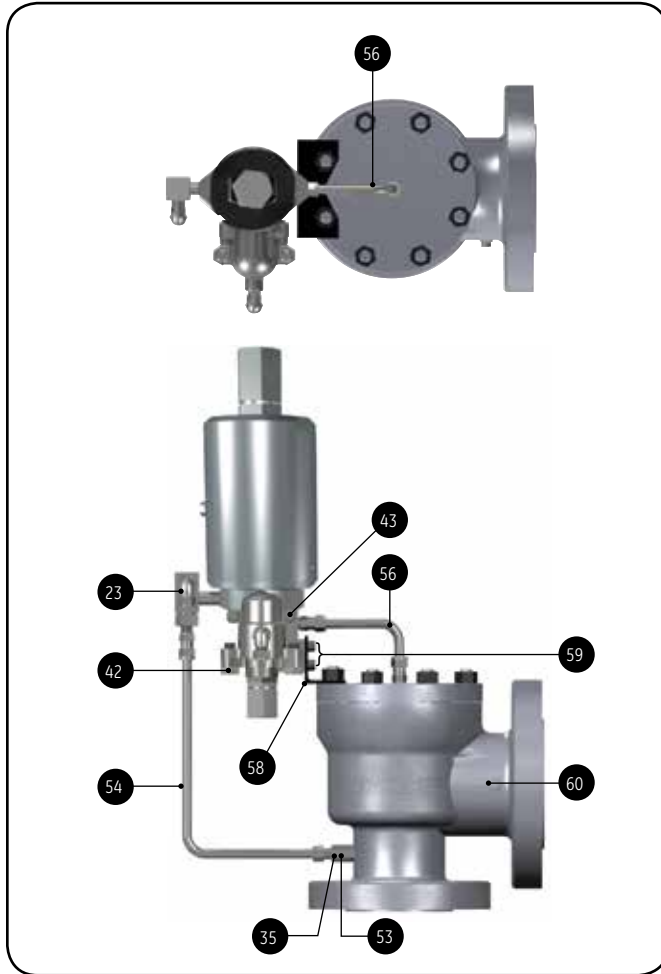

Pilot Valve with Manual Blowdown  
(Optional for All Media Applications)

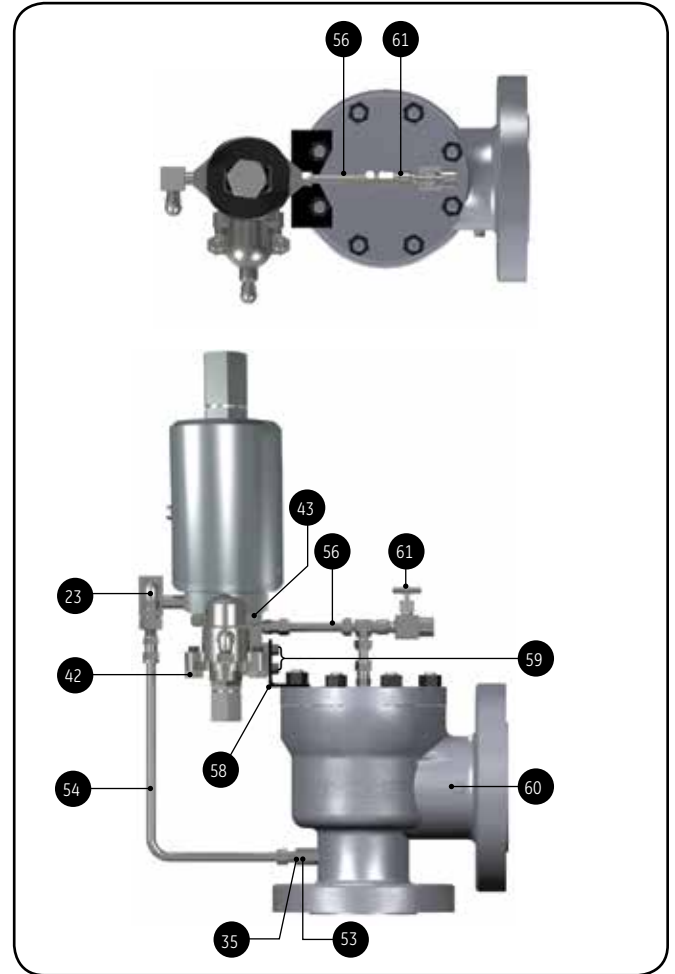

Pilot Valve with Standard Field Test Connection  
(Standard for All Media Applications)

Ref. No.	Part	Material
23	Field Test Connection	316 Stainless Steel
35	Plug Filter	316 Stainless Steel
42	Mod. Cap Screw	316 Stainless Steel
43	Soc. Head Cap Screw	316 Stainless Steel
53	Sensing Tube	316 Stainless Steel
54	Sensing Line	316 Stainless Steel
56	Dome Line	316 Stainless Steel
58	Bracket	Carbon Steel
59	Bracket Cap Screw	316 Stainless Steel
60	Pipe Plug	Carbon Steel

Pilot Valve with Manual Blowdown  
(Optional for All Media Applications)

Ref. No.	Part	Material
23	Field Test Connection	316 Stainless Steel
35	Plug Filter	316 Stainless Steel
42	Mod. Cap Screw	316 Stainless Steel
43	Soc. Head Cap Screw	316 Stainless Steel
53	Sensing Tube	316 Stainless Steel
54	Sensing Line	316 Stainless Steel
56	Dome Line	316 Stainless Steel
58	Bracket	Carbon Steel
59	Bracket Cap Screw	316 Stainless Steel
60	Pipe Plug	Carbon Steel
61	Needle Valve (Manual Blowdown)	316 Stainless Steel

# Piping Configurations

## 39MPV Series Type 39MV Pilot with Single Outlet

(Pilot Vented to Atmosphere)

Pilot Valve with Pilot Supply Filter  
(Optional for All Media Applications)

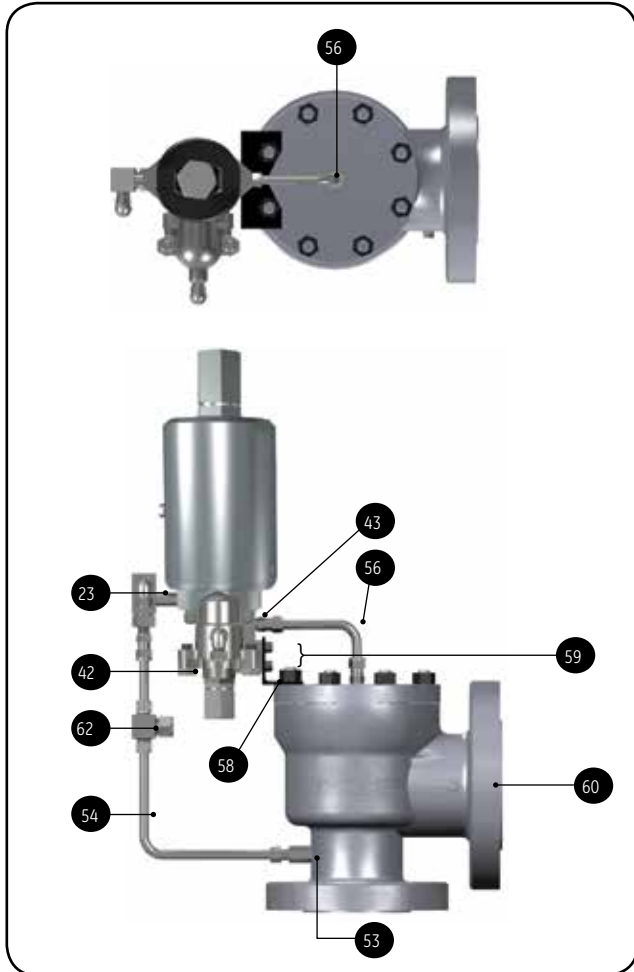

Pilot Valve with Backflow Preventer  
(Optional for Liquid and Gas Applications)

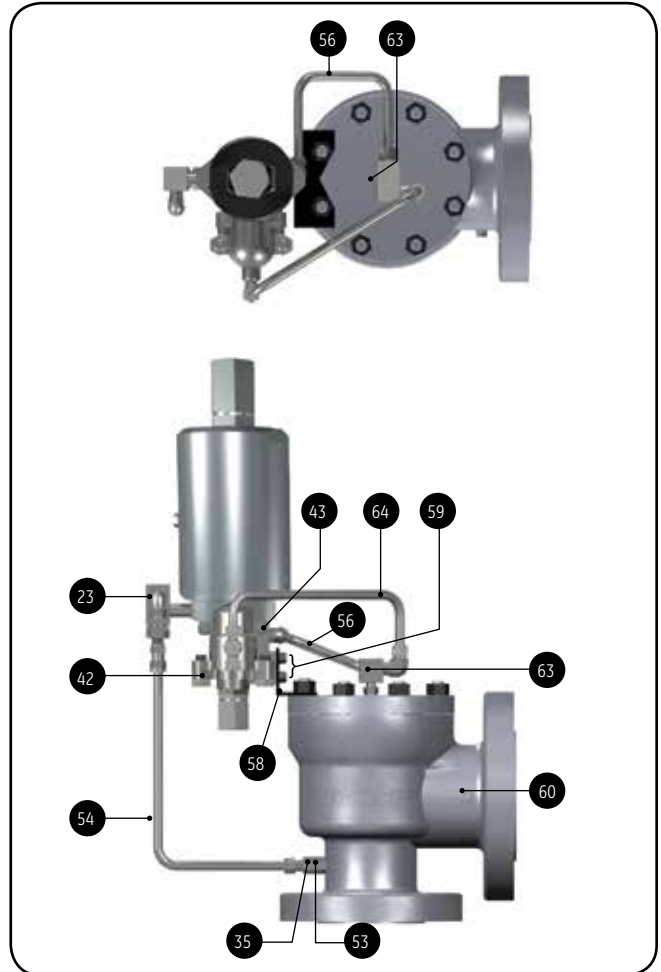

Pilot Valve with Pilot Supply Filter  
(Optional for All Media Applications)

Ref. No.	Part	Material
23	Field Test Connection	316 Stainless Steel
42	Mod. Cap Screw	316 Stainless Steel
43	Soc. Head Cap Screw	316 Stainless Steel
53	Sensing Tube	316 Stainless Steel
54	Sensing Line	316 Stainless Steel
56	Dome Line	316 Stainless Steel
58	Bracket	Carbon Steel
59	Bracket Cap Screw	316 Stainless Steel
60	Pipe Plug	Carbon Steel
62	Pilot Supply Filter	316 Stainless Steel

Pilot Valve with Backflow Preventer  
(Optional for Liquid and Gas Applications)

Ref. No.	Part	Material
23	Field Test Connection	316 Stainless Steel
35	Plug Filter	316 Stainless Steel
42	Mod. Cap Screw	316 Stainless Steel
43	Soc. Head Cap Screw	316 Stainless Steel
53	Sensing Tube	316 Stainless Steel
54	Sensing Line	316 Stainless Steel
56	Dome Line	316 Stainless Steel
58	Bracket	Carbon Steel
59	Bracket Cap Screw	316 Stainless Steel
60	Pipe Plug	Carbon Steel
63	Backflow Preventer	316 Stainless Steel
64	Backflow Preventer Line	316 Stainless Steel

# Piping Configurations

## 39MPV Series Type 39MV Pilot with Single Outlet

(Pilot Vented to Atmosphere)

Pilot Valve with Manual Blowdown and Pilot Supply Filter (Standard for Steam Applications)  
(Optional for Liquid and Gas Applications)

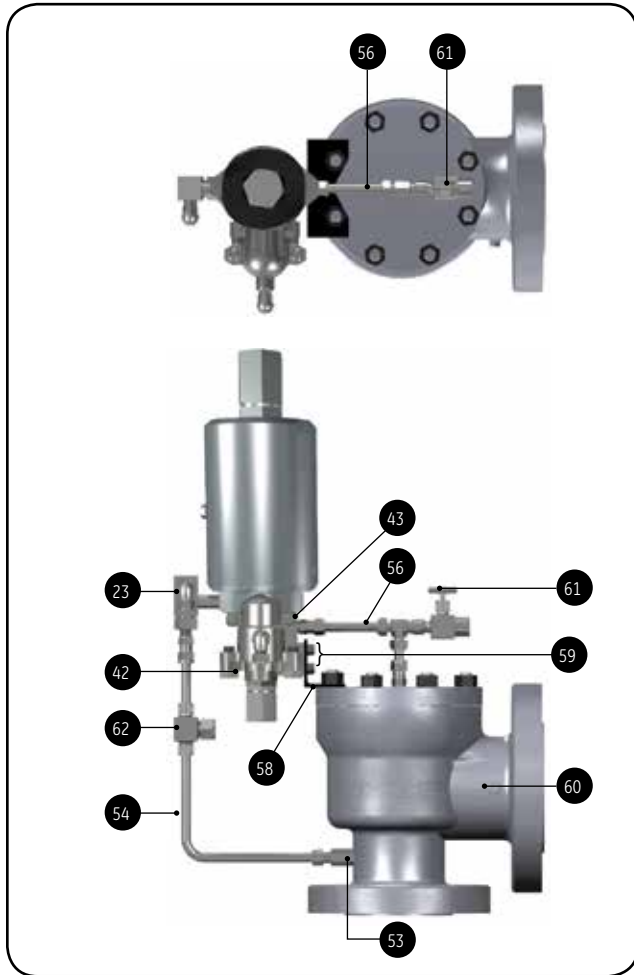

Pilot Valve with Manual Blowdown, Pilot Supply Filter and Backflow Preventer (Optional For Steam Applications)

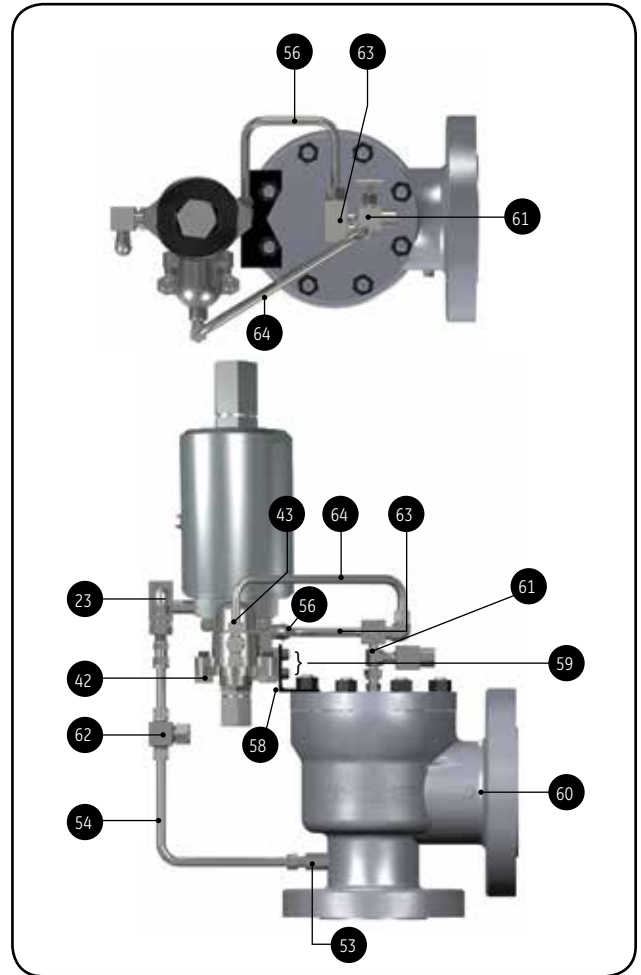

Pilot Valve with Manual Blowdown and Pilot Supply Filter (Standard for Steam Applications)  
(Optional for Liquid and Gas Applications)

Ref. No.	Part	Material
23	Field Test Connection	316 Stainless Steel
42	Mod. Cap Screw	316 Stainless Steel
43	Soc. Head Cap Screw	316 Stainless Steel
53	Sensing Tube	316 Stainless Steel
54	Sensing Line	316 Stainless Steel
56	Dome Line	316 Stainless Steel
58	Bracket	Carbon Steel
59	Bracket Cap Screw	316 Stainless Steel
60	Pipe Plug	Carbon Steel
61	Needle Valve (Manual Blowdown)	316 Stainless Steel
62	Pilot Supply Filter	316 Stainless Steel

Pilot Valve with Manual Blowdown, Pilot Supply Filter and Backflow Preventer (Optional For Steam Applications)

Ref. No.	Part	Material
23	Field Test Connection	316 Stainless Steel
42	Mod. Cap Screw	316 Stainless Steel
43	Soc. Head Cap Screw	316 Stainless Steel
53	Sensing Tube	316 Stainless Steel
54	Sensing Line	316 Stainless Steel
56	Dome Line	316 Stainless Steel
58	Bracket	Carbon Steel
59	Bracket Cap Screw	316 Stainless Steel
60	Pipe Plug	Carbon Steel
61	Needle Valve (Manual Blowdown)	316 Stainless Steel
62	Pilot Supply Filter	316 Stainless Steel
63	Backflow Preventer	316 Stainless Steel
64	Backflow Preventer Line	316 Stainless Steel

# Piping Configurations

## 39MPV Series Type 39MV Pilot with Double Outlet

(Pilot Vented to Atmosphere)

Pilot Valve with Field Test Connection  
(Standard for All Media Applications)

Pilot Valve with Manual Blowdown  
(Optional for All Media Applications)

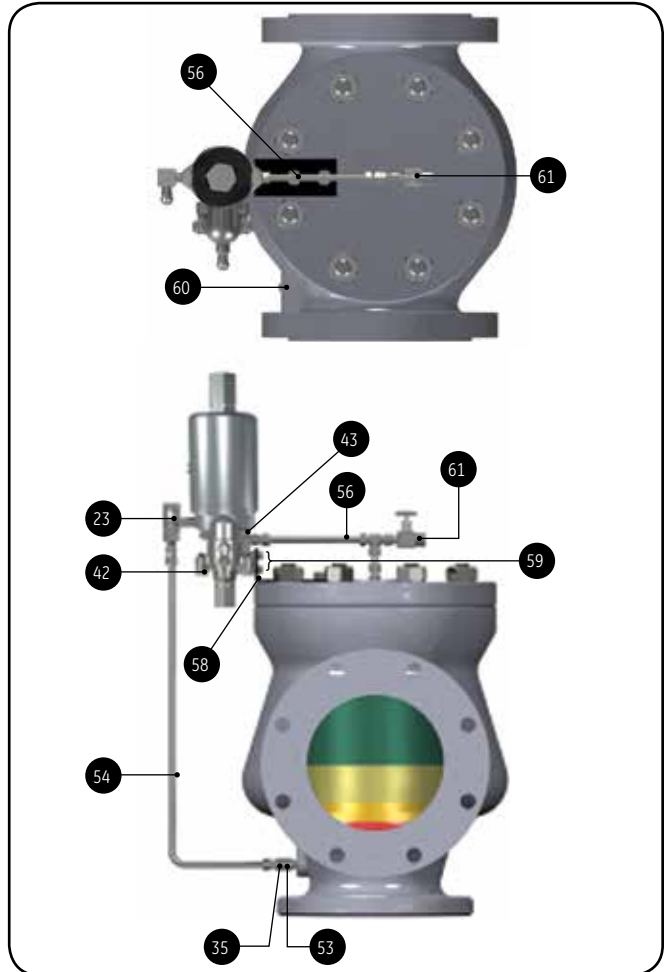
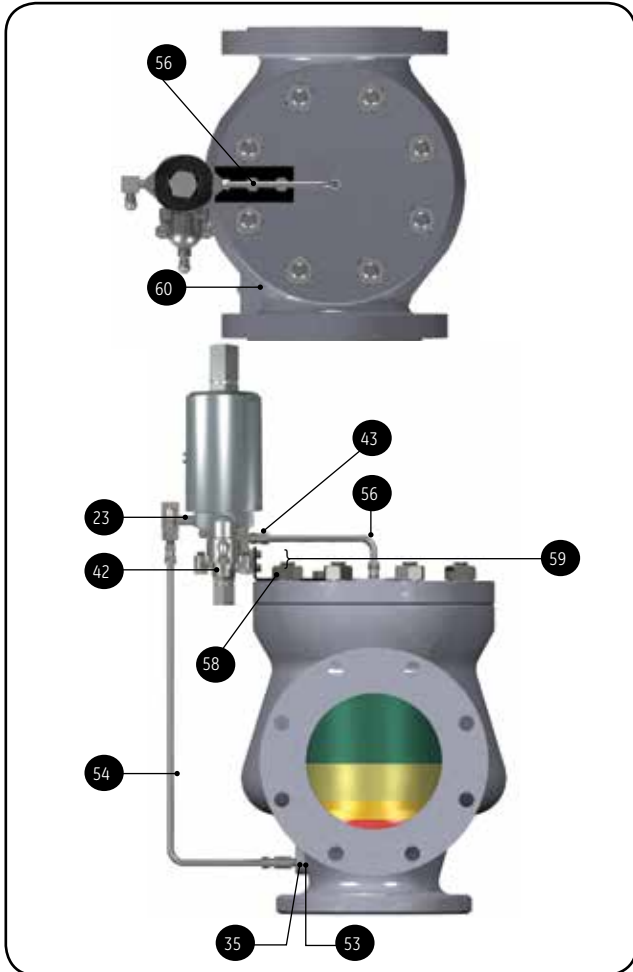

Pilot Valve with Field Test Connection  
(Standard for All Media Applications)

Ref. No.	Part	Material
23	Field Test Connection	316 Stainless Steel
35	Plug Filter	316 Stainless Steel
42	Mod. Cap Screw	316 Stainless Steel
43	Soc. Head Cap Screw	316 Stainless Steel
53	Sensing Tube	316 Stainless Steel
54	Sensing Line	316 Stainless Steel
56	Dome Line	316 Stainless Steel
58	Bracket	Carbon Steel
59	Bracket Cap Screw	316 Stainless Steel
60	Pipe Plug	Carbon Steel

Pilot Valve with Manual Blowdown  
(Optional for All Media Applications)

Ref. No.	Part	Material
23	Field Test Connection	316 Stainless Steel
35	Plug Filter	316 Stainless Steel
42	Mod. Cap Screw	316 Stainless Steel
43	Soc. Head Cap Screw	316 Stainless Steel
53	Sensing Tube	316 Stainless Steel
54	Sensing Line	316 Stainless Steel
56	Dome Line	316 Stainless Steel
58	Bracket	Carbon Steel
59	Bracket Cap Screw	316 Stainless Steel
60	Pipe Plug	Carbon Steel
61	Needle Valve (Manual Blowdown)	316 Stainless Steel

# Piping Configurations

## 39MPV Series Type 39MV Pilot with Double Outlet

(Pilot Vented to Atmosphere)

Pilot Valve with Pilot Supply Filter  
(Optional for All Media Applications)

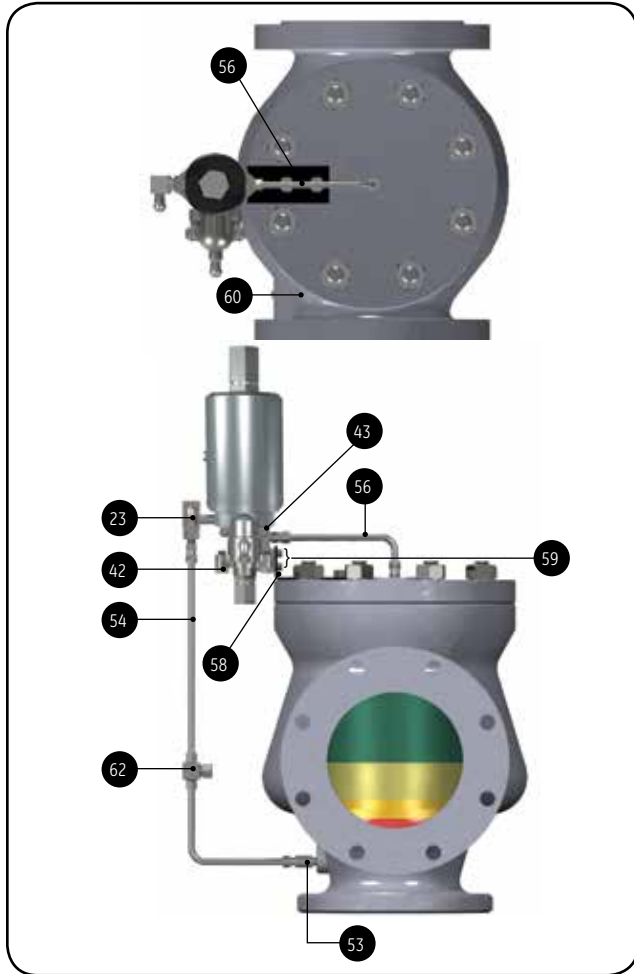

Pilot Valve with Backflow Preventer  
(Optional for Liquid and Gas Applications)

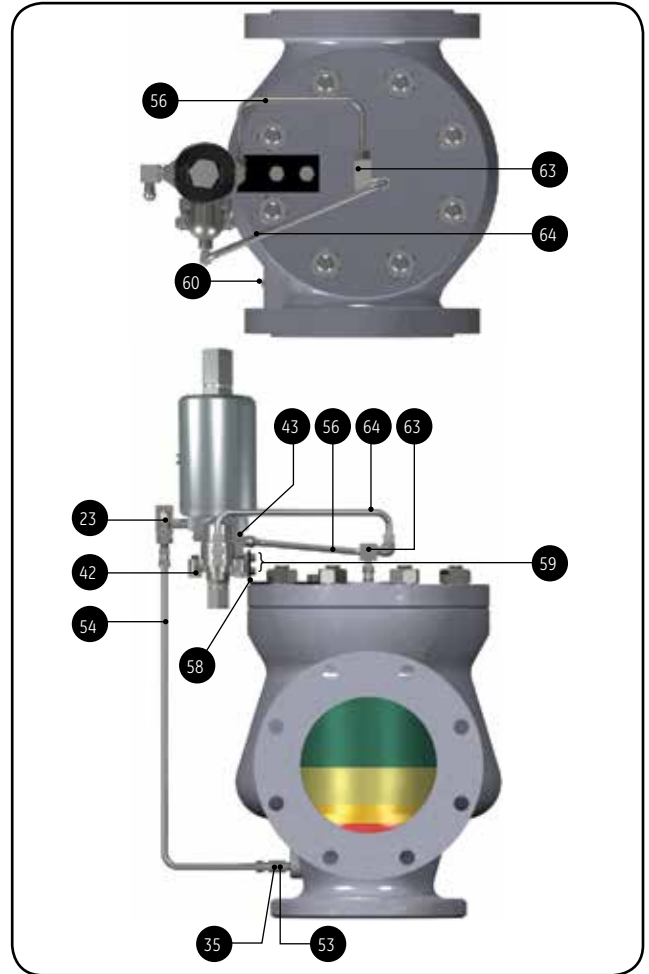

Pilot Valve with Pilot Supply Filter  
(Optional for All Media Applications)

Ref. No.	Part	Material
23	Field Test Connection	316 Stainless Steel
42	Mod. Cap Screw	316 Stainless Steel
43	Soc. Head Cap Screw	316 Stainless Steel
53	Sensing Tube	316 Stainless Steel
54	Sensing Line	316 Stainless Steel
56	Dome Line	316 Stainless Steel
58	Bracket	Carbon Steel
59	Bracket Cap Screw	316 Stainless Steel
60	Pipe Plug	Carbon Steel
62	Pilot Supply Filter	316 Stainless Steel

Pilot Valve with Backflow Preventer  
(Optional for Liquid and Gas Applications)

Ref. No.	Part	Material
23	Field Test Connection	316 Stainless Steel
35	Plug Filter	316 Stainless Steel
42	Mod. Cap Screw	316 Stainless Steel
43	Soc. Head Cap Screw	316 Stainless Steel
53	Sensing Tube	316 Stainless Steel
54	Sensing Line	316 Stainless Steel
56	Dome Line	316 Stainless Steel
58	Bracket	Carbon Steel
59	Bracket Cap Screw	316 Stainless Steel
60	Pipe Plug	Carbon Steel
63	Backflow Preventer	316 Stainless Steel
64	Backflow Preventer Line	316 Stainless Steel

# Piping Configurations

## 39MPV Series Type 39MV Pilot with Double Outlet

(Pilot Vented to Atmosphere)

Pilot Valve with Manual Blowdown and Pilot Supply Filter (Standard for Steam Applications)  
(Optional for Liquid and Gas Applications)

Pilot Valve with Manual Blowdown, Pilot Supply Filter and Backflow Preventer (Optional for Steam Applications)

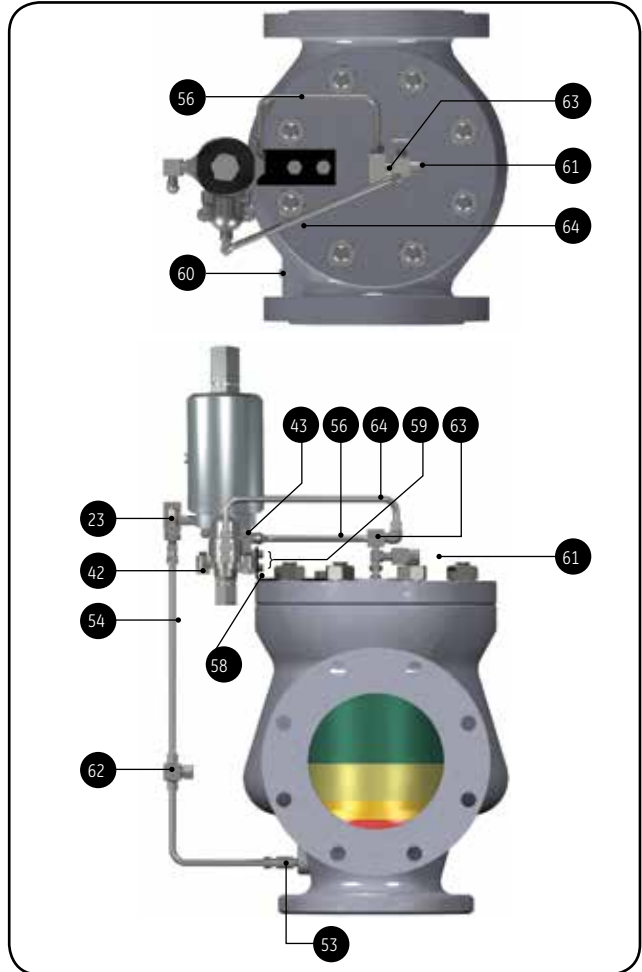
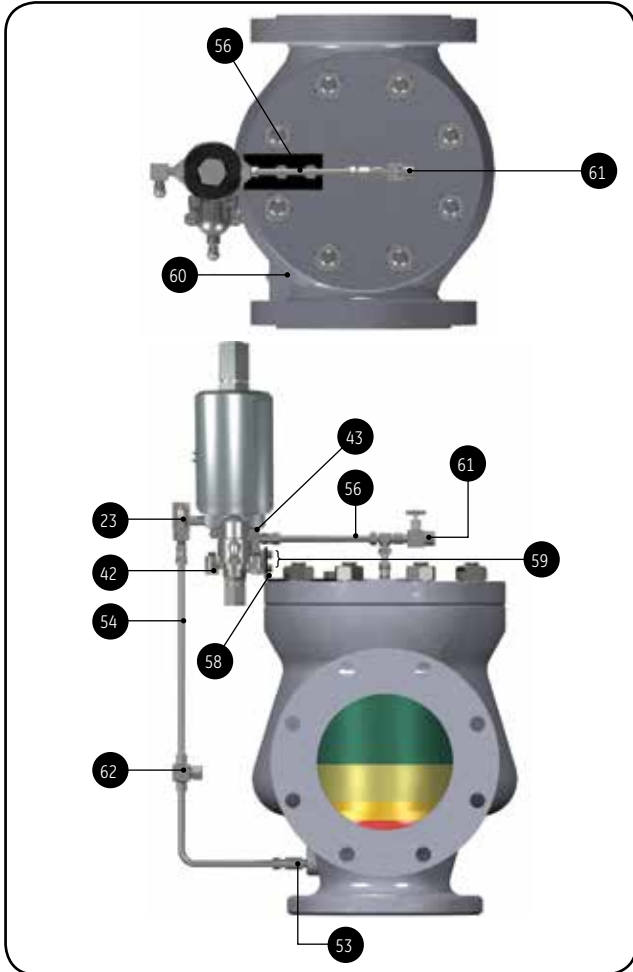

Pilot Valve with Manual Blowdown and Pilot Supply Filter (Standard for Steam Applications)  
(Optional for Liquid and Gas Applications)

Ref. No.	Part	Material
23	Field Test Connection	316 Stainless Steel
42	Mod. Cap Screw	316 Stainless Steel
43	Soc. Head Cap Screw	316 Stainless Steel
53	Sensing Tube	316 Stainless Steel
54	Sensing Line	316 Stainless Steel
56	Dome Line	316 Stainless Steel
58	Bracket	Carbon Steel
59	Bracket Cap Screw	316 Stainless Steel
60	Pipe Plug	Carbon Steel
61	Needle Valve (Manual Blowdown)	316 Stainless Steel
62	Pilot Supply Filter	316 Stainless Steel

Pilot Valve with Manual Blowdown, Pilot Supply Filter and Backflow Preventer (Optional for Steam Applications)

Ref. No.	Part	Material
23	Field Test Connection	316 Stainless Steel
42	Mod. Cap Screw	316 Stainless Steel
43	Soc. Head Cap Screw	316 Stainless Steel
53	Sensing Tube	316 Stainless Steel
54	Sensing Line	316 Stainless Steel
56	Dome Line	316 Stainless Steel
58	Bracket	Carbon Steel
59	Bracket Cap Screw	316 Stainless Steel
60	Pipe Plug	Carbon Steel
61	Needle Valve (Manual Blowdown)	316 Stainless Steel
62	Pilot Supply Filter	316 Stainless Steel
63	Backflow Preventer	316 Stainless Steel
64	Backflow Preventer Line	316 Stainless Steel

# Piping Configurations

## Alternate Piping Arrangements

3900 Series Type 39PV Pilot with Single Outlet (Pilot Vented to Body Bowl)

Pilot Valve with Standard Field Test Connection  
(Standard For All Media Applications)

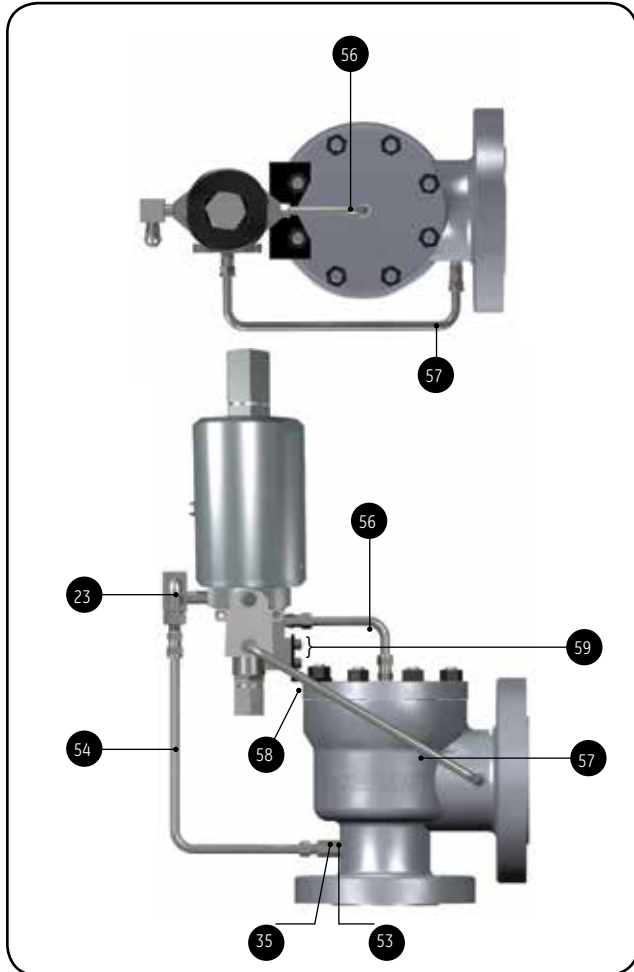

Pilot Valve with Manual Blowdown  
(Optional For All Media Applications)

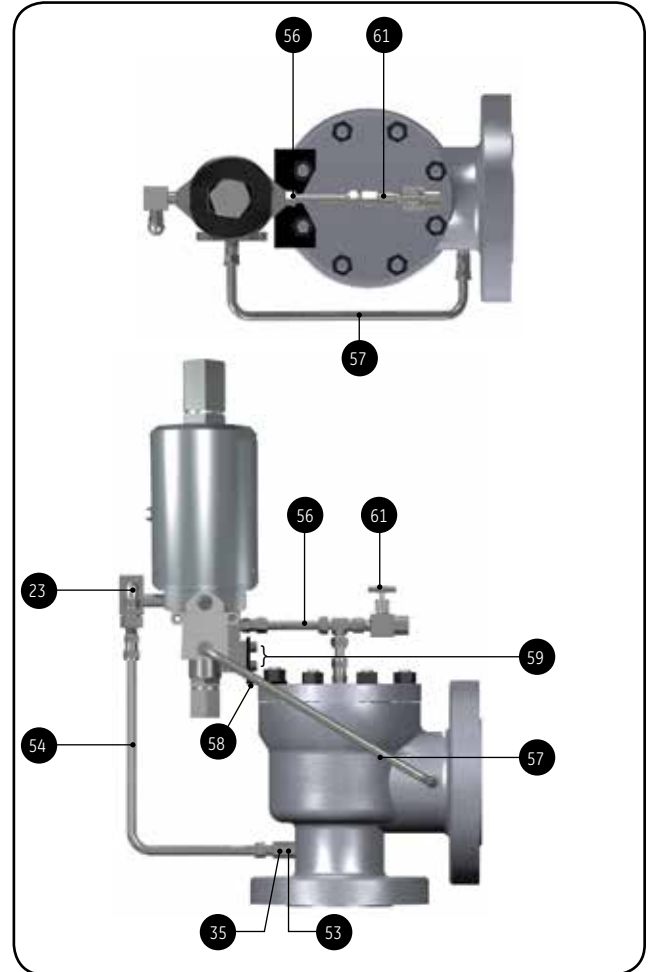

Pilot Valve with Standard Field Test Connection (Standard For All Media Applications)

Ref. No.	Part	Material
23	Field Test Connection	316 Stainless Steel
35	Plug Filter	316 Stainless Steel
53	Sensing Tube	316 Stainless Steel
54	Sensing Line	316 Stainless Steel
56	Dome Line	316 Stainless Steel
57	Discharge Line	316 Stainless Steel
58	Bracket	Carbon Steel
59	Bracket Cap Screw	316 Stainless Steel

Pilot Valve with Manual Blowdown (Optional For All Media Applications)

Ref. No.	Part	Material
23	Field Test Connection	316 Stainless Steel
35	Plug Filter	316 Stainless Steel
53	Sensing Tube	316 Stainless Steel
54	Sensing Line	316 Stainless Steel
56	Dome Line	316 Stainless Steel
57	Discharge Line	316 Stainless Steel
58	Bracket	Carbon Steel
59	Bracket Cap Screw	316 Stainless Steel
61	Needle Valve (Manual Blowdown)	316 Stainless Steel

# Piping Configurations

## 39MPV Series Type 39PV Pilot with Single Outlet

(Pilot Vented to Body Bowl)

Pilot Valve with Pilot Supply Filter  
(Optional For All Media Applications)

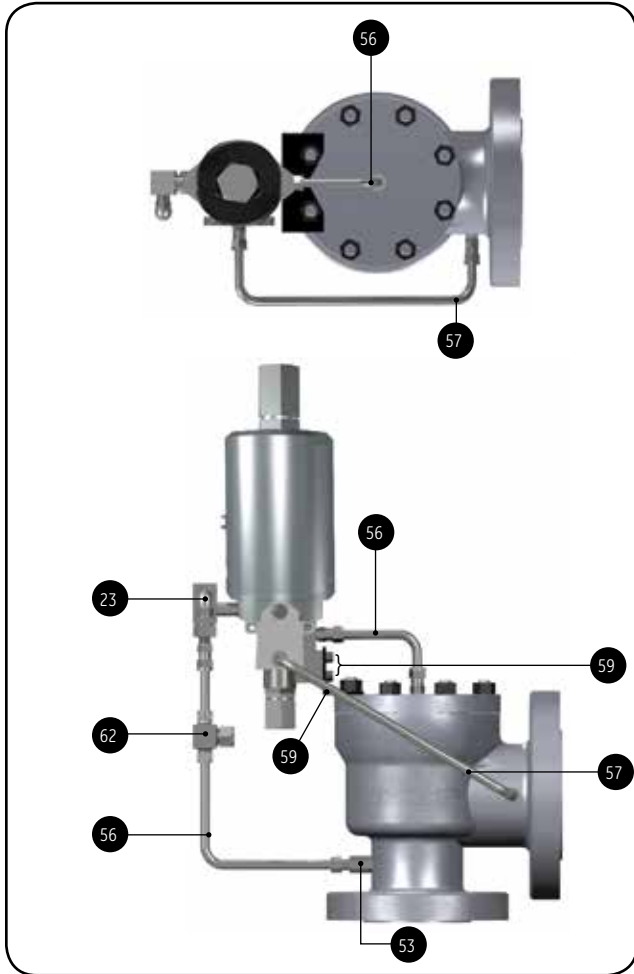

Pilot Valve with Backflow Preventer  
(Optional For Liquid and Gas Applications)

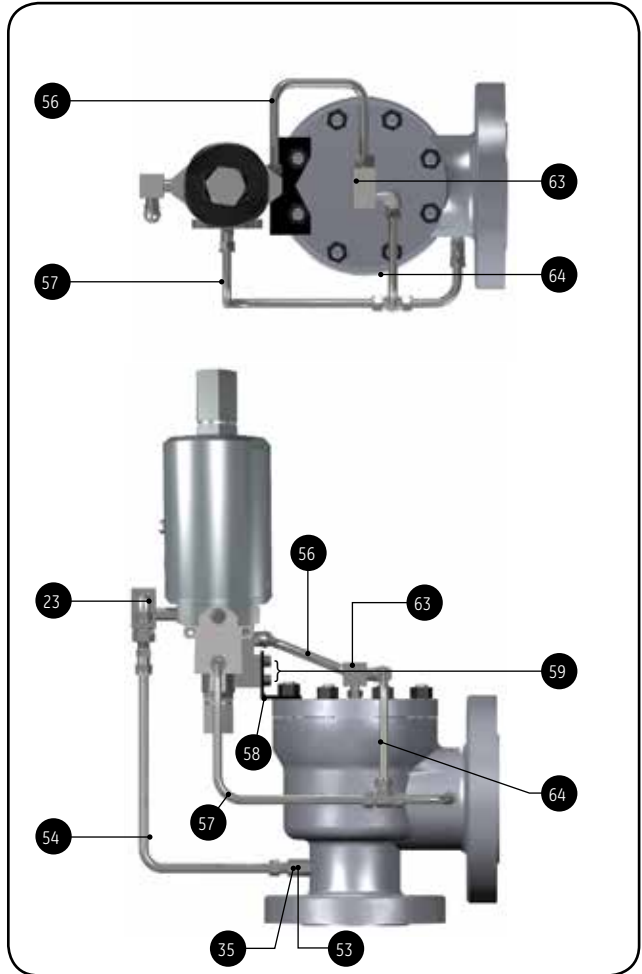

Pilot Valve with Pilot Supply Filter (Optional For All Media Applications)		
Ref. No.	Part	Material
23	Field Test Connection	316 Stainless Steel
53	Sensing Tube	316 Stainless Steel
54	Sensing Line	316 Stainless Steel
56	Dome Line	316 Stainless Steel
57	Discharge Line	316 Stainless Steel
58	Bracket	Carbon Steel
59	Bracket Cap Screw	316 Stainless Steel
62	Pilot Supply Filter	316 Stainless Steel

Pilot Valve with Backflow Preventer (Optional For Liquid and Gas Applications)		
Ref. No.	Part	Material
23	Field Test Connection	316 Stainless Steel
35	Plug Filter	316 Stainless Steel
53	Sensing Tube	316 Stainless Steel
54	Sensing Line	316 Stainless Steel
56	Dome Line	316 Stainless Steel
57	Discharge Line	316 Stainless Steel
58	Bracket	Carbon Steel
59	Bracket Cap Screw	316 Stainless Steel
63	Backflow Preventer	316 Stainless Steel
64	Backflow Preventer Line	316 Stainless Steel



# Piping Configurations

## 39MPV Series Type 39PV Pilot with Single Outlet

(Pilot Vented to Body Bowl)

Pilot Valve with Manual Blowdown and Pilot Supply Filter (Standard for Steam Applications)  
(Optional for Liquid and Gas Applications)

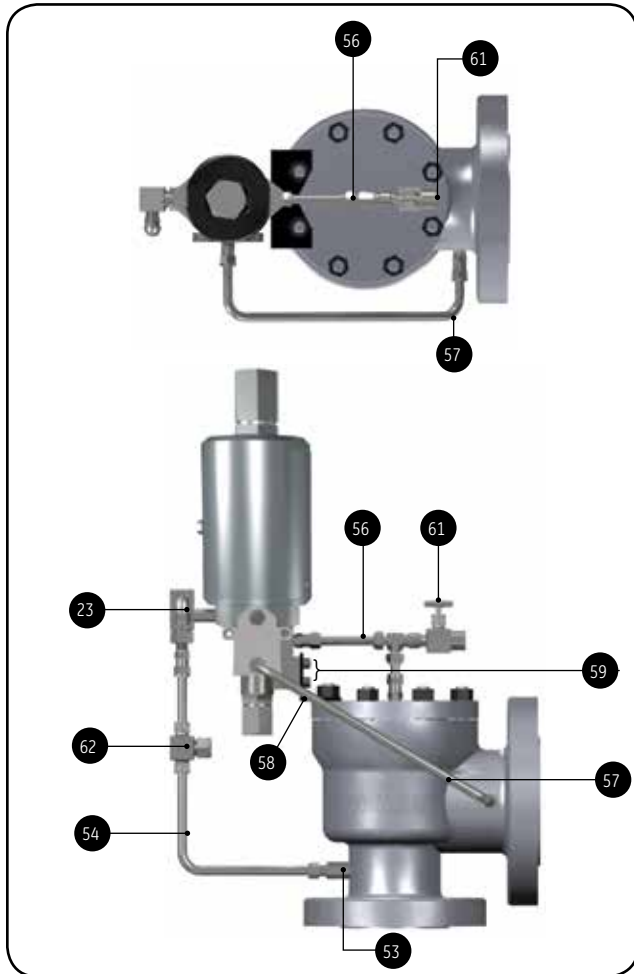

Pilot Valve with Manual Blowdown,  
Pilot Supply Filter and Backflow Preventer  
(Optional For Steam Applications)

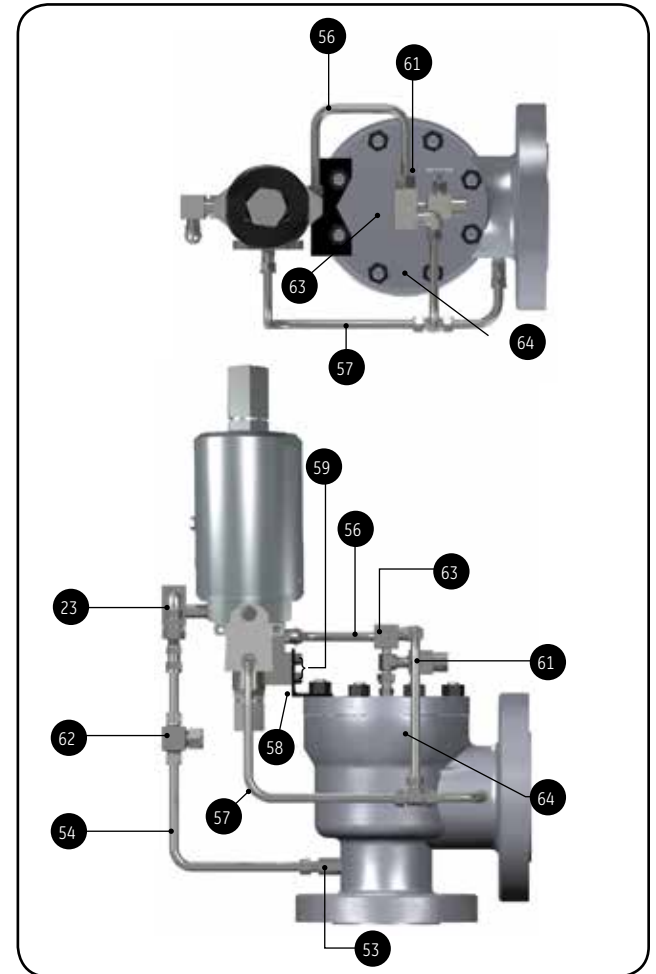

**Pilot Valve with Manual Blowdown and Pilot Supply Filter  
(Standard for Steam Applications)  
(Optional for Liquid and Gas Applications)**

Ref. No.	Part	Material
23	Field Test Connection	316 Stainless Steel
53	Sensing Tube	316 Stainless Steel
54	Sensing Line	316 Stainless Steel
56	Dome Line	316 Stainless Steel
57	Discharge Line	316 Stainless Steel
58	Bracket	Carbon Steel
59	Bracket Cap Screw	316 Stainless Steel
61	Needle Valve (Manual Blowdown)	316 Stainless Steel
62	Pilot Supply Filter	316 Stainless Steel

**Pilot Valve with Manual Blowdown,  
Pilot Supply Filter and Backflow Preventer  
(Optional For Steam Applications)**

Ref. No.	Part	Material
23	Field Test Connection	316 Stainless Steel
53	Sensing Tube	316 Stainless Steel
54	Sensing Line	316 Stainless Steel
56	Dome Line	316 Stainless Steel
57	Discharge Line	316 Stainless Steel
58	Bracket	Carbon Steel
59	Bracket Cap Screw	316 Stainless Steel
61	Needle Valve (Manual Blowdown)	316 Stainless Steel
62	Pilot Supply Filter	316 Stainless Steel
63	Backflow Preventer	316 Stainless Steel
64	Backflow Preventer Line	316 Stainless Steel

# Piping Configurations

## 39MPV Series Type 39PV Pilot with Double Outlet

(Pilot Vented to Body Bowl)

Pilot Valve with Field Test Connection  
(Standard For All Media Applications)

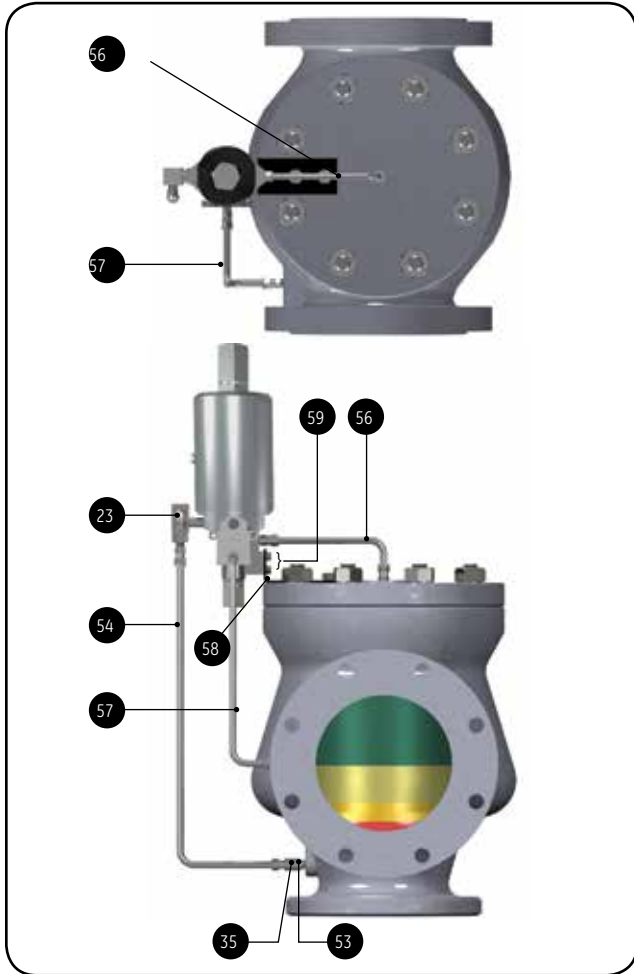

Pilot Valve with Manual Blowdown  
(Optional For Liquid and Gas Applications)

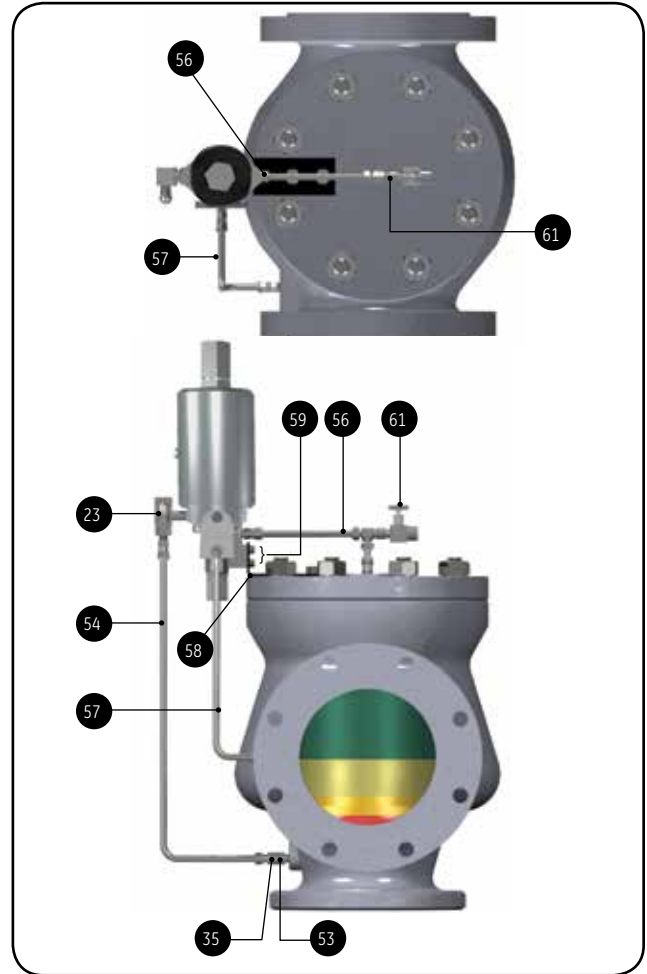

Pilot Valve with Field Test Connection (Standard For All Media Applications)		
Ref. No.	Part	Material
23	Field Test Connection	316 Stainless Steel
35	Plug Filter	316 Stainless Steel
53	Sensing Tube	316 Stainless Steel
54	Sensing Line	316 Stainless Steel
56	Dome Line	316 Stainless Steel
57	Discharge Line	316 Stainless Steel
58	Bracket	Carbon Steel
59	Bracket Cap Screw	316 Stainless Steel

Pilot Valve with Manual Blowdown (Optional For Liquid and Gas Applications)		
Ref. No.	Part	Material
23	Field Test Connection	316 Stainless Steel
35	Plug Filter	316 Stainless Steel
53	Sensing Tube	316 Stainless Steel
54	Sensing Line	316 Stainless Steel
56	Dome Line	316 Stainless Steel
57	Discharge Line	316 Stainless Steel
58	Bracket	Carbon Steel
59	Bracket Cap Screw	316 Stainless Steel
61	Needle Valve (Manual Blowdown)	316 Stainless Steel

# Piping Configurations

## 39MPV Series Type 39PV Pilot with Double Outlet

(Pilot Vented to Body Bowl)

Pilot Valve with Pilot Supply Filter  
(Optional For All Media Applications)

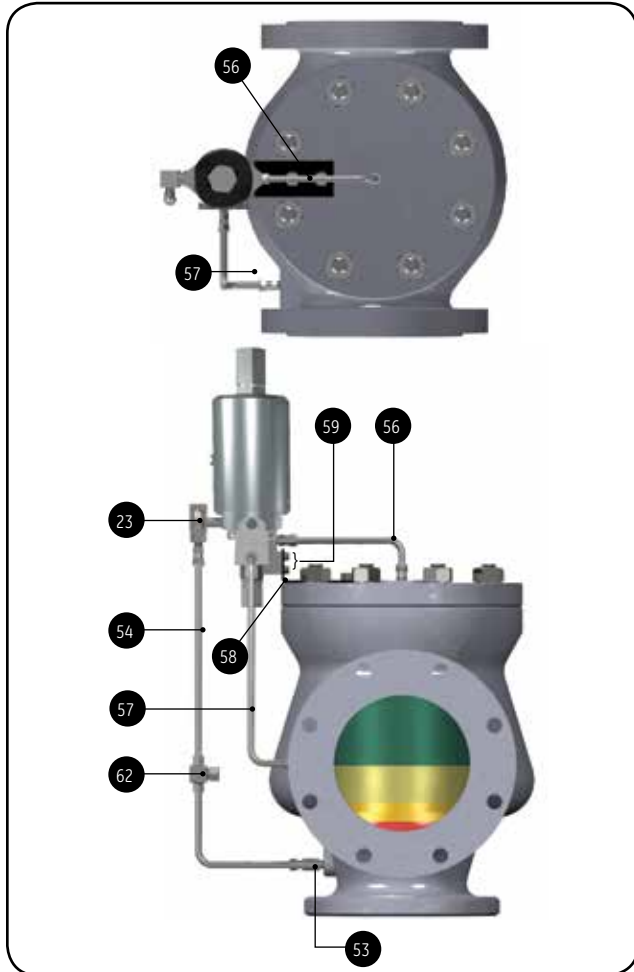

Pilot Valve with Backflow Preventer  
(Optional For Liquid and Gas Applications)

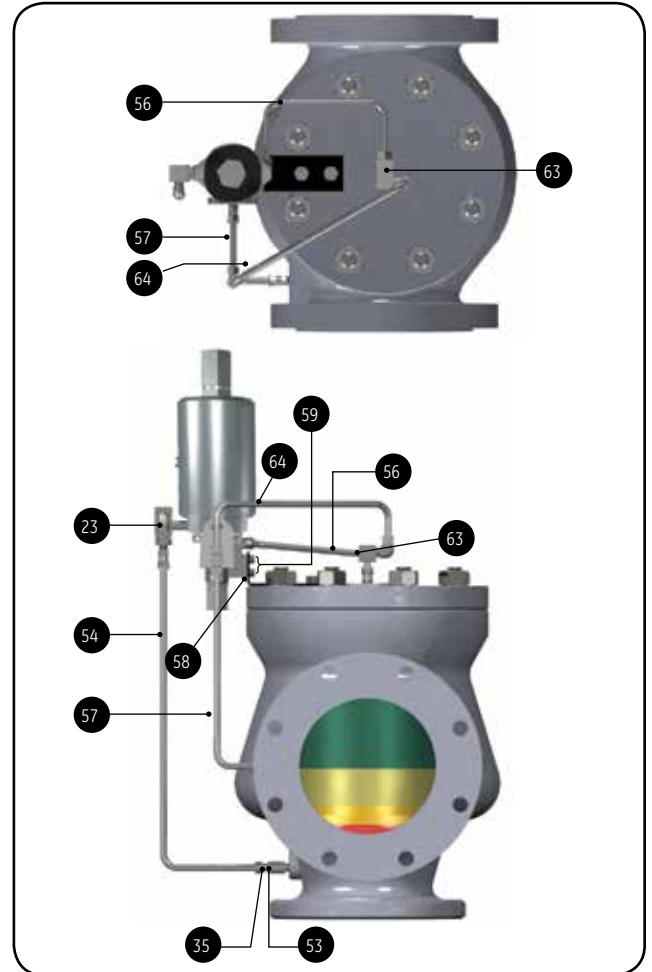

Pilot Valve with Pilot Supply Filter  
(Optional For All Media Applications)

Ref. No.	Part	Material
23	Field Test Connection	316 Stainless Steel
53	Sensing Tube	316 Stainless Steel
54	Sensing Line	316 Stainless Steel
56	Dome Line	316 Stainless Steel
57	Discharge Line	316 Stainless Steel
58	Bracket	Carbon Steel
59	Bracket Cap Screw	316 Stainless Steel
62	Pilot Supply Filter	316 Stainless Steel

Pilot Valve with Backflow Preventer  
(Optional For Liquid and Gas Applications)

Ref. No.	Part	Material
23	Field Test Connection	316 Stainless Steel
35	Plug Filter	316 Stainless Steel
53	Sensing Tube	316 Stainless Steel
54	Sensing Line	316 Stainless Steel
56	Dome Line	316 Stainless Steel
57	Discharge Line	316 Stainless Steel
58	Bracket	Carbon Steel
59	Bracket Cap Screw	316 Stainless Steel
63	Backflow Preventer	316 Stainless Steel
64	Backflow Preventer Line	316 Stainless Steel

# Piping Configurations

## 39MPV Series Type 39PV Pilot with Double Outlet

(Pilot Vented to Body Bowl)

Pilot Valve with Manual Blowdown and Pilot Supply Filter (Standard for Steam Applications) (Optional for Liquid and Gas Applications)

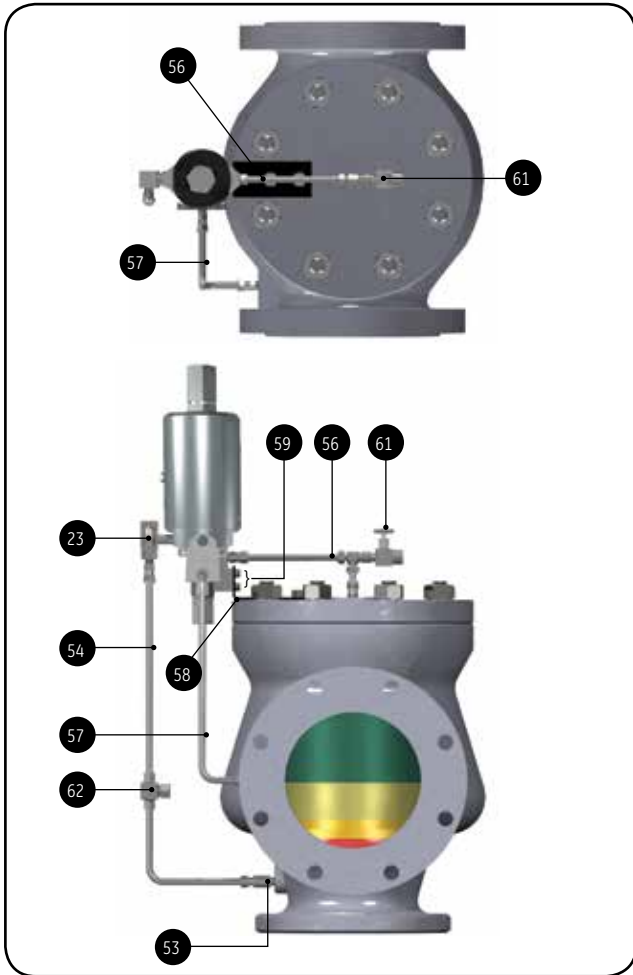

Pilot Valve with Manual Blowdown, Pilot Supply Filter and Backflow Preventer (Optional For Steam Applications)

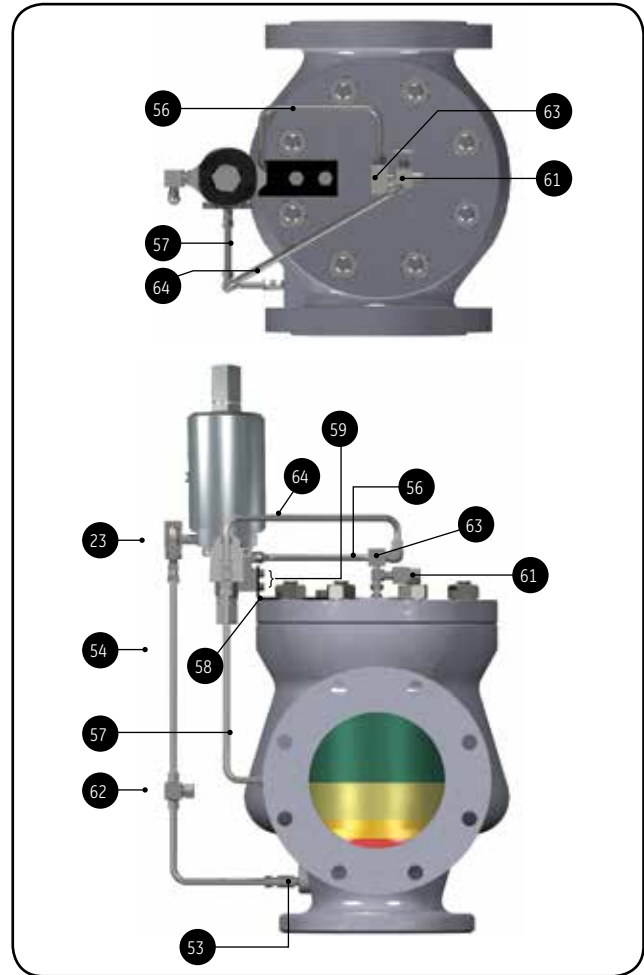

Pilot Valve with Manual Blowdown and Pilot Supply Filter (Standard for Steam Applications) (Optional for Liquid and Gas Applications)

Ref. No.	Part	Material
23	Field Test Connection	316 Stainless Steel
53	Sensing Tube	316 Stainless Steel
54	Sensing Line	316 Stainless Steel
56	Dome Line	316 Stainless Steel
57	Discharge Line	316 Stainless Steel
58	Bracket	Carbon Steel
59	Bracket Cap Screw	316 Stainless Steel
61	Needle Valve (Manual Blowdown)	316 Stainless Steel
62	Pilot Supply Filter	316 Stainless Steel

Pilot Valve with Manual Blowdown, Pilot Supply Filter and Backflow Preventer (Optional For Steam Applications)

Ref. No.	Part	Material
23	Field Test Connection	316 Stainless Steel
53	Sensing Tube	316 Stainless Steel
54	Sensing Line	316 Stainless Steel
56	Dome Line	316 Stainless Steel
57	Discharge Line	316 Stainless Steel
58	Bracket	Carbon Steel
59	Bracket Cap Screw	316 Stainless Steel
61	Needle Valve (Manual Blowdown)	316 Stainless Steel
62	Pilot Supply Filter	316 Stainless Steel
63	Backflow Preventer	316 Stainless Steel
64	Backflow Preventer Line	316 Stainless Steel

# Piping Configurations

## 39MPV Series Type 39MV Pilot with Single Outlet

(Pilot Vented to Body Bowl)

Pilot Valve with Standard Field Test Connection  
(Standard for All Media Applications)

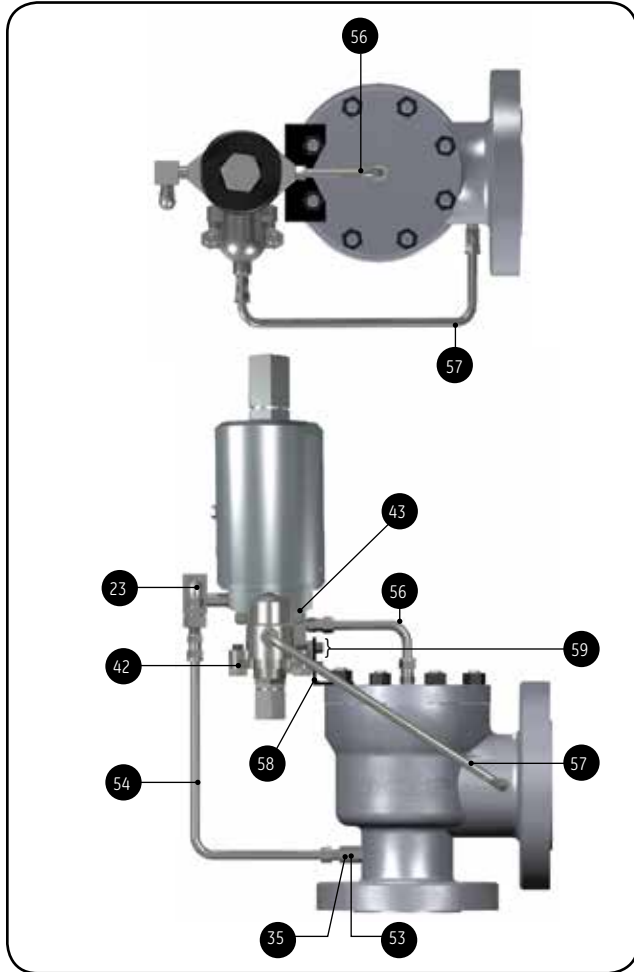

Pilot Valve with Manual Blowdown  
(Optional for All Media Applications)

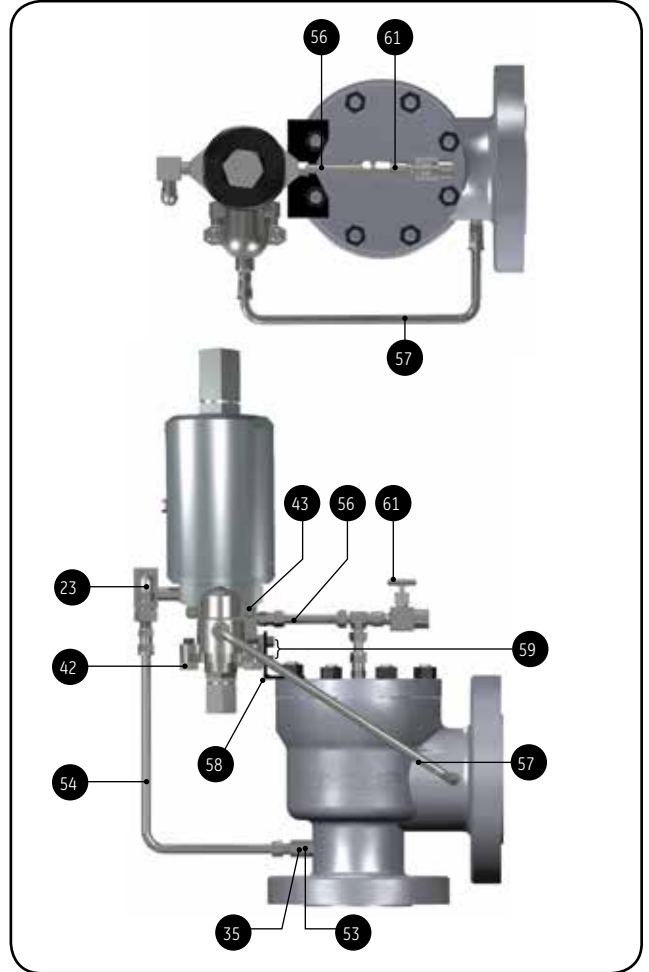

Pilot Valve with Standard Field Test Connection  
(Standard for All Media Applications)

Ref. No.	Part	Material
23	Field Test Connection	316 Stainless Steel
35	Plug Filter	316 Stainless Steel
32	Mod. Cap Screw	316 Stainless Steel
43	Soc. Head Cap Screw	316 Stainless Steel
53	Sensing Tube	316 Stainless Steel
54	Sensing Line	316 Stainless Steel
56	Dome Line	316 Stainless Steel
57	Discharge Line	316 Stainless Steel
58	Bracket	Carbon Steel
59	Bracket Cap Screw	316 Stainless Steel

Pilot Valve with Manual Blowdown  
(Optional for All Media Applications)

Ref. No.	Part	Material
23	Field Test Connection	316 Stainless Steel
35	Plug Filter	316 Stainless Steel
42	Mod. Cap Screw	316 Stainless Steel
43	Soc. Head Cap Screw	316 Stainless Steel
53	Sensing Tube	316 Stainless Steel
54	Sensing Line	316 Stainless Steel
56	Dome Line	316 Stainless Steel
57	Discharge Line	316 Stainless Steel
58	Bracket	Carbon Steel
59	Bracket Cap Screw	316 Stainless Steel
61	Needle Valve (Manual Blowdown)	316 Stainless Steel

# Piping Configurations

## 39MPV Series Type 39MV Pilot with Single Outlet

(Pilot Vented to Body Bowl)

Pilot Valve with Pilot Supply Filter  
(Optional for All Media Applications)

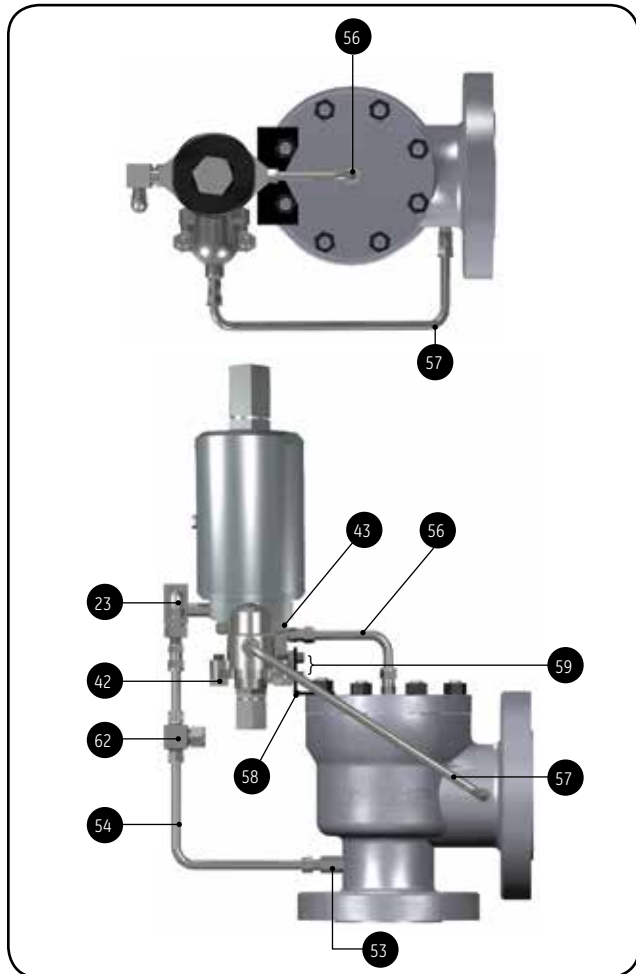

Pilot Valve with Backflow Preventer  
(Optional for Liquid and Gas Applications)

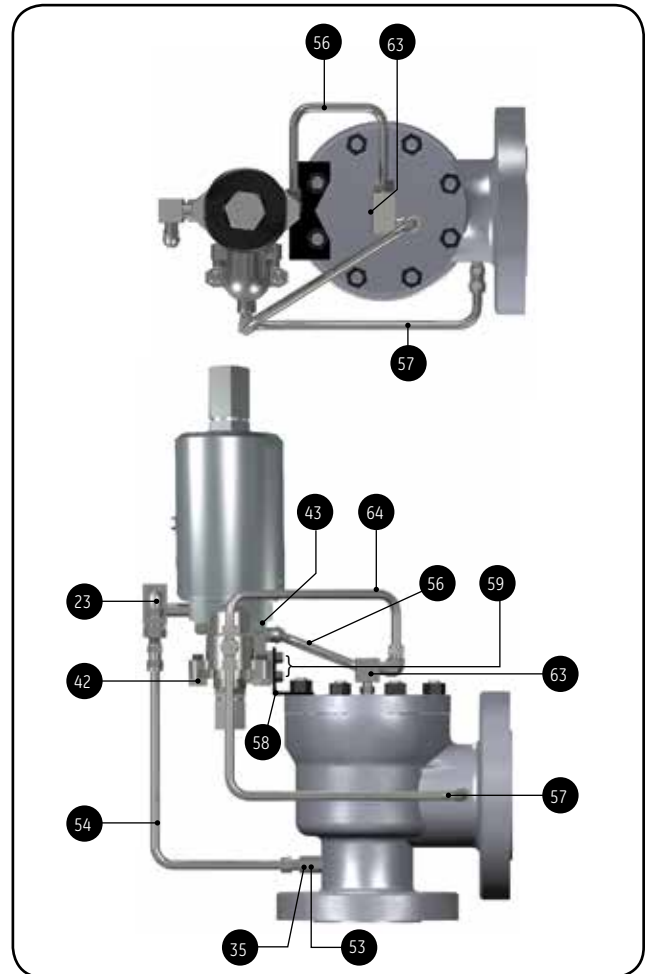

Pilot Valve with Pilot Supply Filter  
(Optional for All Media Applications)

Ref. No.	Part	Material
23	Field Test Connection	316 Stainless Steel
42	Mod. Cap Screw	316 Stainless Steel
43	Soc. Head Cap Screw	316 Stainless Steel
53	Sensing Tube	316 Stainless Steel
54	Sensing Line	316 Stainless Steel
56	Dome Line	316 Stainless Steel
57	Discharge Line	316 Stainless Steel
58	Bracket	Carbon Steel
59	Bracket Cap Screw	316 Stainless Steel
62	Pilot Supply Filter	316 Stainless Steel

Pilot Valve with Backflow Preventer  
(Optional for Liquid and Gas Applications)

Ref. No.	Part	Material
23	Field Test Connection	316 Stainless Steel
35	Plug Filter	316 Stainless Steel
42	Mod. Cap Screw	316 Stainless Steel
43	Soc. Head Cap Screw	316 Stainless Steel
53	Sensing Tube	316 Stainless Steel
54	Sensing Line	316 Stainless Steel
56	Dome Line	316 Stainless Steel
57	Discharge Line	316 Stainless Steel
58	Bracket	Carbon Steel
59	Bracket Cap Screw	316 Stainless Steel
63	Backflow Preventer	316 Stainless Steel
64	Backflow Preventer Line	316 Stainless Steel

# Piping Configurations

## 39MPV Series Type 39MV Pilot with Single Outlet

(Pilot Vented to Body Bowl)

Pilot Valve with Manual Blowdown and Pilot Supply Filter (Standard for Steam Applications)  
(Optional for Liquid and Gas Applications)

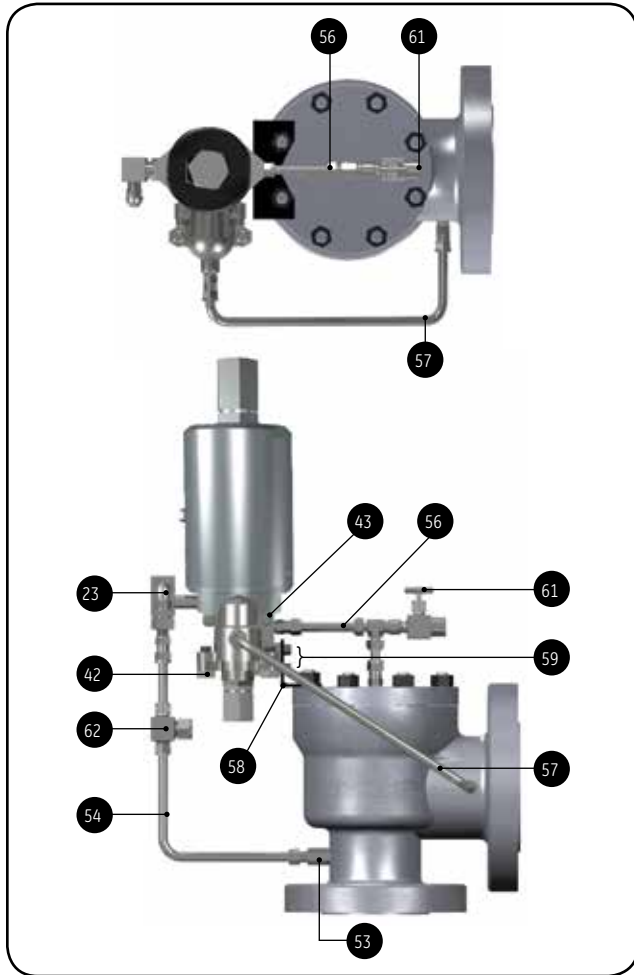

Pilot Valve with Manual Blowdown, Pilot Supply Filter and backflow preventer (Standard for Steam Applications)

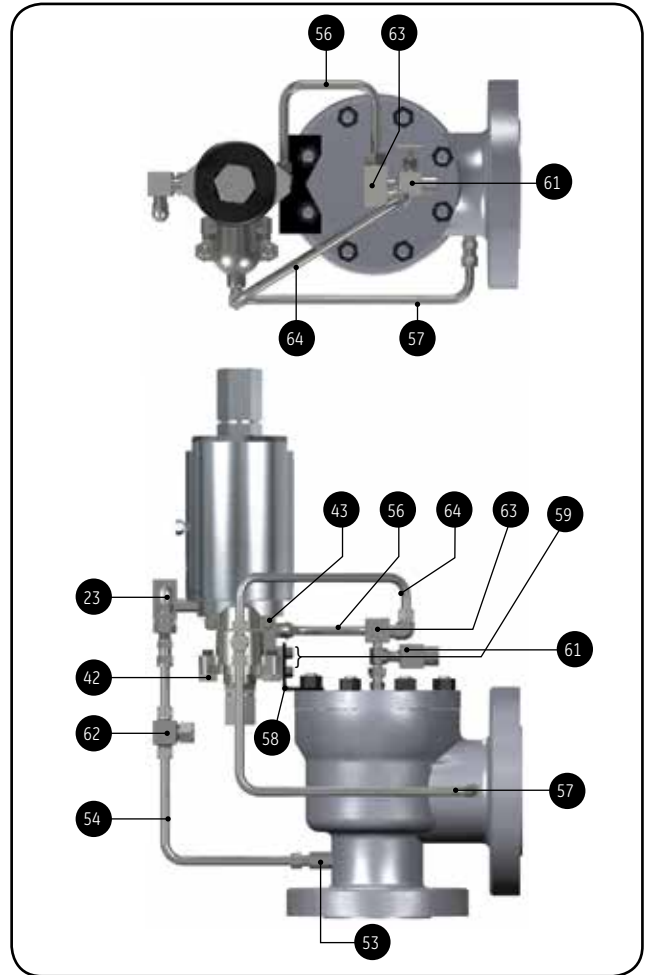

Pilot Valve with Manual Blowdown and Pilot Supply Filter (Standard for Steam Applications)  
(Optional for Liquid and Gas Applications)

Ref. No.	Part	Material
23	Field Test Connection	316 Stainless Steel
42	Mod. Cap Screw	316 Stainless Steel
43	Soc. Head Cap Screw	316 Stainless Steel
53	Sensing Tube	316 Stainless Steel
54	Sensing Line	316 Stainless Steel
56	Dome Line	316 Stainless Steel
57	Discharge Line	316 Stainless Steel
58	Bracket	Carbon Steel
59	Bracket Cap Screw	316 Stainless Steel
61	Needle Valve (Manual Blowdown)	316 Stainless Steel
62	Pilot Supply Filter	316 Stainless Steel

Pilot Valve with Manual Blowdown, Pilot Supply Filter and backflow preventer (Standard for Steam Applications)

Ref. No.	Part	Material
23	Field Test Connection	316 Stainless Steel
42	Mod. Cap Screw	316 Stainless Steel
43	Soc. Head Cap Screw	316 Stainless Steel
53	Sensing Tube	316 Stainless Steel
54	Sensing Line	316 Stainless Steel
56	Dome Line	316 Stainless Steel
57	Discharge Line	316 Stainless Steel
58	Bracket	Carbon Steel
59	Bracket Cap Screw	316 Stainless Steel
61	Needle Valve (Manual Blowdown)	316 Stainless Steel
62	Pilot Supply Filter	316 Stainless Steel
63	Backflow Preventer	316 Stainless Steel
64	Backflow Preventer Line	316 Stainless Steel

# Piping Configurations

## 39MPV Series Type 39MV Pilot with Double Outlet

(Pilot Vented to Body Bowl)

Pilot Valve with Field Test Connection  
(Standard for All Media Applications)

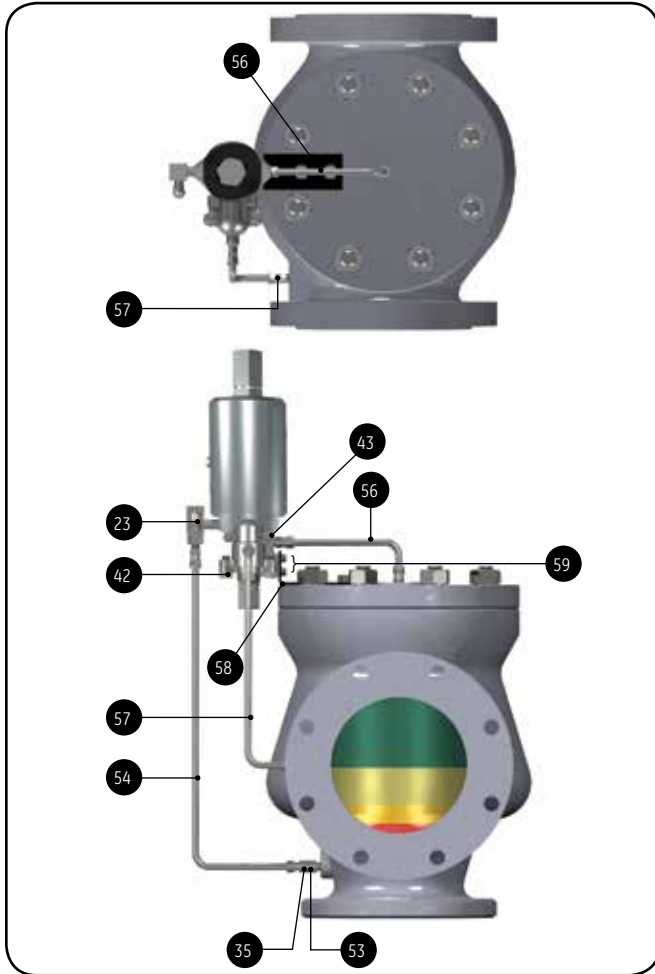

Pilot Valve with Manual Blowdown  
(Optional for All Media Applications)

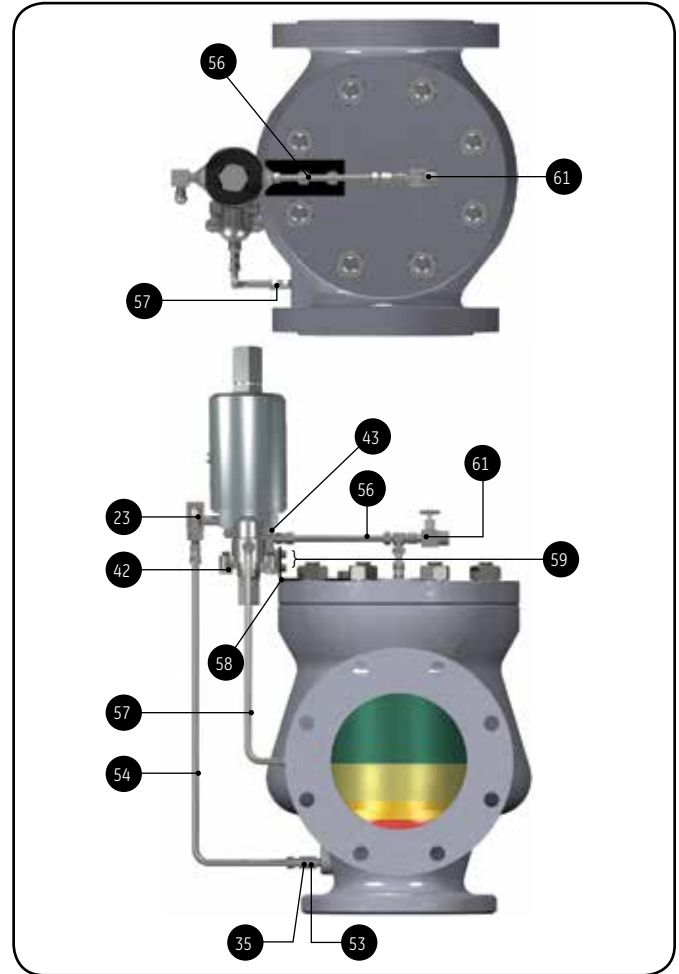

Pilot Valve with Field Test Connection  
(Standard for All Media Applications)

Ref. No.	Part	Material
23	Field Test Connection	316 Stainless Steel
35	Plug Filter	316 Stainless Steel
42	Mod. Cap Screw	316 Stainless Steel
43	Soc. Head Cap Screw	316 Stainless Steel
53	Sensing Tube	316 Stainless Steel
54	Sensing Line	316 Stainless Steel
56	Dome Line	316 Stainless Steel
57	Discharge Line	316 Stainless Steel
58	Bracket	Carbon Steel
59	Bracket Cap Screw	316 Stainless Steel

Pilot Valve with Manual Blowdown  
(Optional for All Media Applications)

Ref. No.	Part	Material
23	Field Test Connection	316 Stainless Steel
35	Plug Filter	316 Stainless Steel
42	Mod. Cap Screw	316 Stainless Steel
43	Soc. Head Cap Screw	316 Stainless Steel
53	Sensing Tube	316 Stainless Steel
54	Sensing Line	316 Stainless Steel
56	Dome Line	316 Stainless Steel
57	Discharge Line	316 Stainless Steel
58	Bracket	Carbon Steel
59	Bracket Cap Screw	316 Stainless Steel
61	Needle Valve (Manual Blowdown)	316 Stainless Steel



# Piping Configurations

## 39MPV Series Type 39MV Pilot with Double Outlet

(Pilot Vented to Body Bowl)

Pilot Valve with Pilot Supply Filter  
(Optional for All Media Applications)

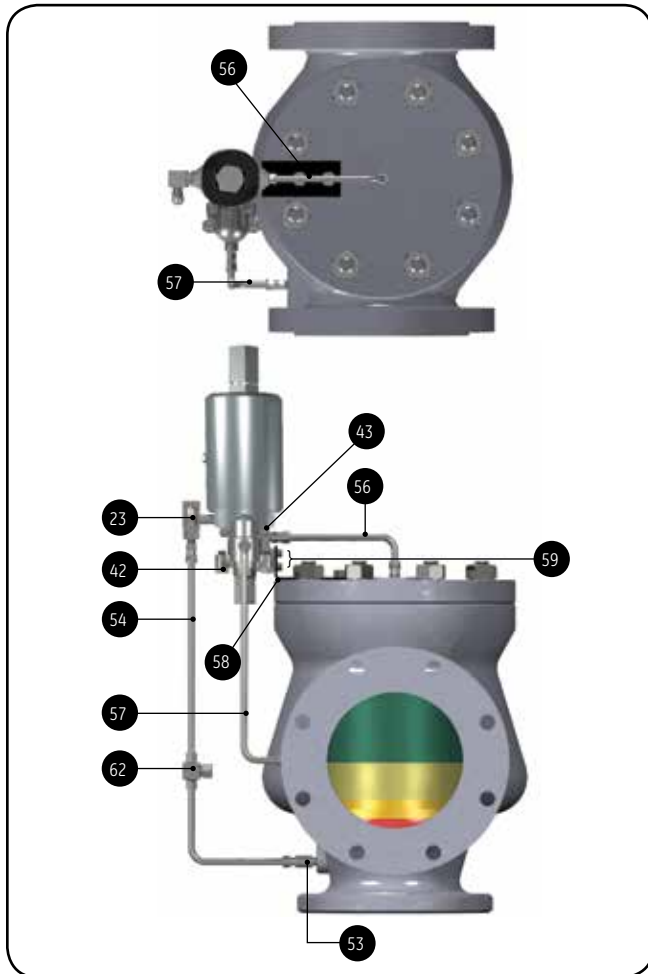

Pilot Valve with Backflow Preventer  
(Optional for Liquid and Gas Applications)

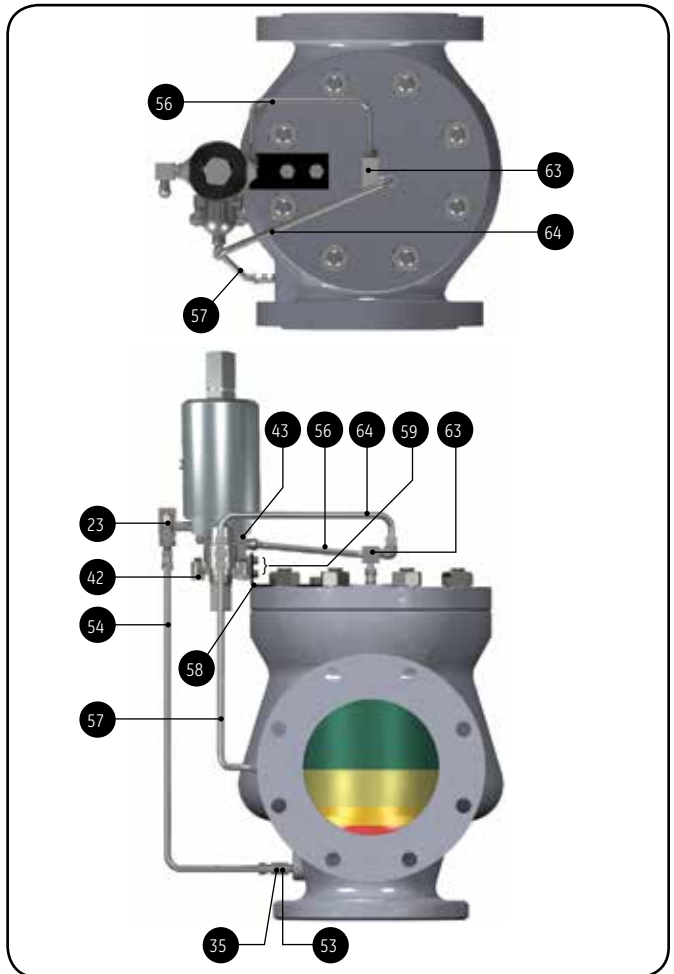

Pilot Valve with Pilot Supply Filter  
(Optional for All Media Applications)

Ref. No.	Part	Material
23	Field Test Connection	316 Stainless Steel
42	Mod. Cap Screw	316 Stainless Steel
43	Soc. Head Cap Screw	316 Stainless Steel
53	Sensing Tube	316 Stainless Steel
54	Sensing Line	316 Stainless Steel
56	Dome Line	316 Stainless Steel
57	Discharge Line	316 Stainless Steel
58	Bracket	Carbon Steel
59	Bracket Cap Screw	316 Stainless Steel
62	Pilot Supply Filter	316 Stainless Steel

Pilot Valve with Backflow Preventer  
(Optional for Liquid and Gas Applications)

Ref. No.	Part	Material
23	Field Test Connection	316 Stainless Steel
35	Plug Filter	316 Stainless Steel
42	Mod. Cap Screw	316 Stainless Steel
43	Soc. Head Cap Screw	316 Stainless Steel
53	Sensing Tube	316 Stainless Steel
54	Sensing Line	316 Stainless Steel
56	Dome Line	316 Stainless Steel
57	Discharge Line	316 Stainless Steel
58	Bracket	Carbon Steel
59	Bracket Cap Screw	316 Stainless Steel
63	Backflow Preventer	316 Stainless Steel
64	Backflow Preventer Line	316 Stainless Steel

# Piping Configurations

## 39MPV Series Type 39MV Pilot with Double Outlet

(Pilot Vented to Body Bowl)

Pilot Valve with Manual Blowdown and Pilot Supply Filter  
(Standard for Steam Applications)  
(Optional for Liquid and Gas Applications)

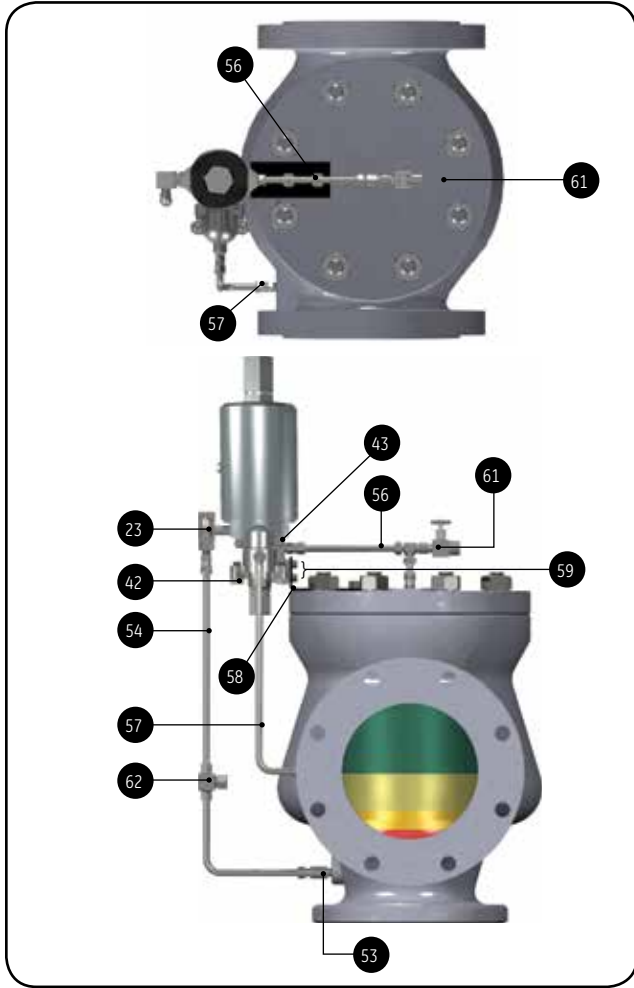

Pilot Valve with Manual Blowdown and Pilot Supply Filter and Backflow Preventer  
(Optional For Steam Applications)

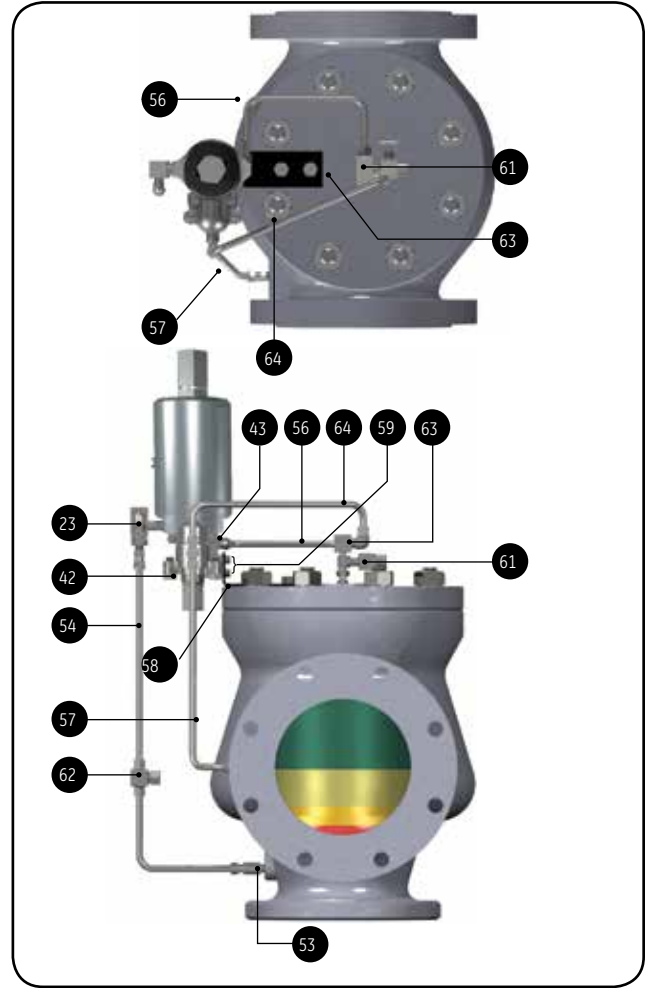

Pilot Valve with Manual Blowdown and Pilot Supply Filter  
(Standard for Steam Applications)  
(Optional for Liquid and Gas Applications)

Ref. No.	Part	Material
23	Field Test Connection	316 Stainless Steel
42	Mod. Cap Screw	316 Stainless Steel
43	Soc. Head Cap Screw	316 Stainless Steel
53	Sensing Tube	316 Stainless Steel
54	Sensing Line	316 Stainless Steel
56	Dome Line	316 Stainless Steel
57	Discharge Line	316 Stainless Steel
58	Bracket	Carbon Steel
59	Bracket Cap Screw	316 Stainless Steel
61	Needle Valve (Manual Blowdown)	316 Stainless Steel
62	Pilot Supply Filter	316 Stainless Steel

Pilot Valve with Manual Blowdown,  
Pilot Supply Filter and Backflow Preventer  
(Optional For Steam Applications)

Ref. No.	Part	Material
23	Field Test Connection	316 Stainless Steel
42	Mod. Cap Screw	316 Stainless Steel
43	Soc. Head Cap Screw	316 Stainless Steel
53	Sensing Tube	316 Stainless Steel
54	Sensing Line	316 Stainless Steel
56	Dome Line	316 Stainless Steel
57	Discharge Line	316 Stainless Steel
58	Bracket	Carbon Steel
59	Bracket Cap Screw	316 Stainless Steel
61	Needle Valve (Manual Blowdown)	316 Stainless Steel
62	Pilot Supply Filter	316 Stainless Steel
63	Backflow Preventer	316 Stainless Steel
64	Backflow Preventer Line	316 Stainless Steel

# Dimensions and Weights

## 3900 Dimensions and Weights Index

39MPV Series with Type 39PV (Pop) Pilot	
Single Outlet - Standard Bore .....	51
Single Outlet - Full Bore.....	53
Double Outlet - Full Bore.....	53
39MPV Series with Type 39MV (Modulating) Pilot	
Single Outlet - Standard Bore .....	52
Single Outlet - Full Bore.....	54
Double Outlet - Full Bore.....	54

## 39MPV Series Type 39PV and 39MV Pilot Single Outlet, Standard Bore

39PV with Single Outlet - Standard Bore

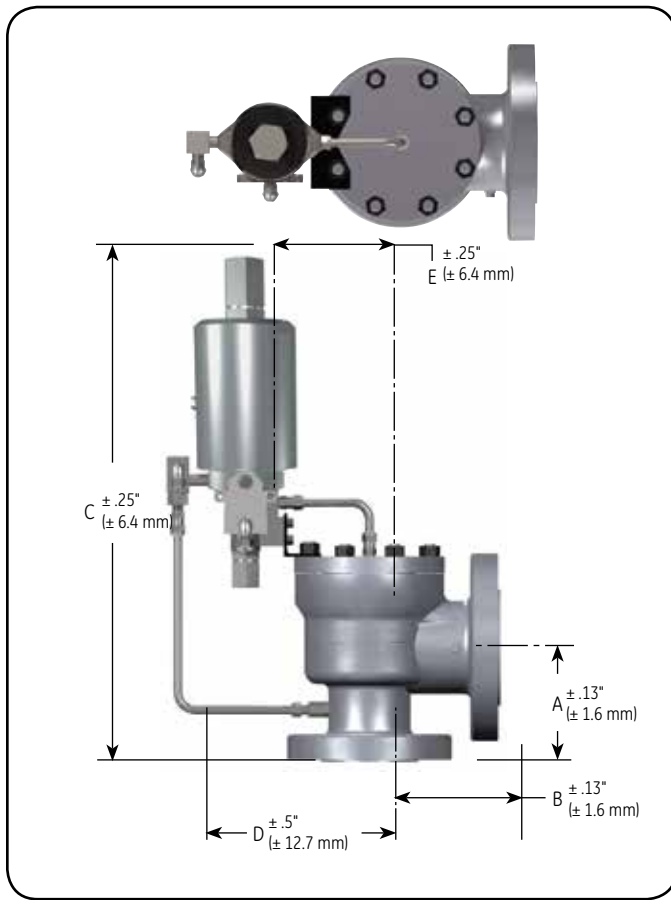

39MV with Single Outlet - Standard Bore

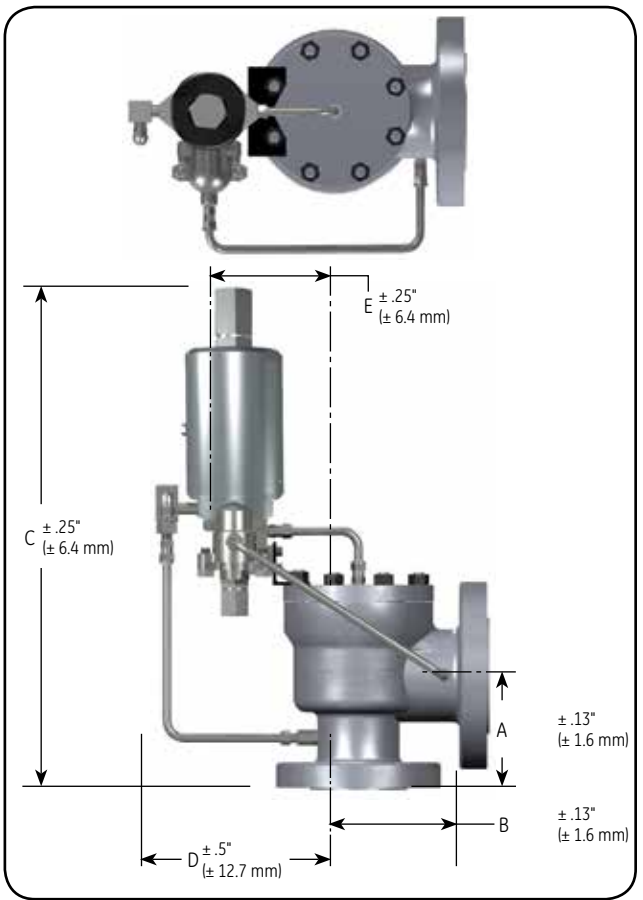

**Note:**

All weights listed in this document are approximations.

# Dimensions and Weights

## 39MPV Series Standard Bore - Dimensions and Weights

Standard Bore Valve Overall Constructed Dimensions																	
Valve Inlet Size		Valve Type	Orifice	A		B		C		D		E		Approximate Weight			
				in	mm	in	mm	in	mm	in	mm	in	mm	PV Pilot		MV Pilot	
in	mm			in	mm	in	mm	in	mm	in	mm	in	mm	lb	kg	lb	kg
1.00	25.4	3905	D, E & F	4.13	104.9	4.50	114.3	21.19	538.2	8.50	215.9	5.19	131.8	39.00	17.69	42.00	19.05
1.00	25.4	3910	D, E & F	4.38	111.3	4.50	114.3	21.44	544.6	8.50	215.9	5.19	131.8	40.00	18.14	43.00	19.50
1.00	25.4	3912	D, E & F	4.38	111.3	4.50	114.3	21.44	544.6	8.50	215.9	5.19	131.8	43.00	19.50	46.00	20.87
1.00	25.4	3914	D, E & F	4.94	125.5	4.75	120.7	22.00	558.8	8.50	215.9	5.19	131.8	49.00	22.23	52.00	23.59
1.00	25.4	3916	D, E & F	4.94	125.5	4.75	120.7	22.00	558.8	8.50	215.9	5.19	131.8	49.00	22.23	52.00	23.59
1.00	25.4	3918	D, E & F	4.94	125.5	4.75	120.7	22.00	558.8	8.50	215.9	5.19	131.8	56.00	25.40	59.00	26.76
1.50	38.1	3905	D, E & F	4.88	124.0	4.75	120.7	21.94	557.3	8.50	215.9	5.19	131.8	46.00	20.87	48.40	21.95
1.50	38.1	3910	D, E & F	4.88	124.0	4.75	120.7	21.94	557.3	8.50	215.9	5.19	131.8	47.00	21.32	50.00	22.68
1.50	38.1	3912	D, E & F	4.88	124.0	4.75	120.7	21.94	557.3	8.50	215.9	5.19	131.8	48.00	21.77	50.20	22.77
1.50	38.1	3914	D, E & F	5.88	149.4	5.50	139.7	22.94	582.7	8.50	215.9	5.19	131.8	61.00	27.67	63.20	28.67
1.50	38.1	3916	D, E & F	5.88	149.4	5.50	139.7	22.94	582.7	8.50	215.9	5.19	131.8	61.00	27.67	63.20	28.67
1.50	38.1	3918	D, E & F	5.88	149.4	5.50	139.7	22.94	582.7	8.50	215.9	5.19	131.8	67.00	30.39	69.00	31.30
1.50	38.1	3905	G & H	5.13	130.3	4.88	124.0	23.31	592.1	9.31	236.5	6.00	152.4	53.00	24.04	56.00	25.40
1.50	38.1	3910	G & H	5.13	130.3	4.88	124.0	23.31	592.1	9.31	236.5	6.00	152.4	55.00	24.95	58.00	26.31
1.50	38.1	3912	G & H	5.13	130.3	4.88	124.0	23.31	592.1	9.31	236.5	6.00	152.4	57.00	25.85	60.00	27.22
1.50	38.1	3914	G & H	6.38	162.1	6.75	171.5	24.56	623.8	9.31	236.5	6.00	152.4	66.00	29.94	69.00	31.30
1.50	38.1	3916	G & H	6.38	162.1	6.75	171.5	24.56	623.8	9.31	236.5	6.00	152.4	66.00	29.94	69.00	31.30
1.50	38.1	3918	G & H	6.38	162.1	6.75	171.5	24.56	623.8	9.31	236.5	6.00	152.4	80.00	36.29	83.00	37.65
2.00	50.8	3905	G, H & J	5.38	136.7	4.88	124.0	23.56	598.4	9.31	236.5	6.00	152.4	53.00	24.04	56.00	25.40
2.00	50.8	3910	G, H & J	5.38	136.7	4.88	124.0	23.56	598.4	9.31	236.5	6.00	152.4	55.00	24.95	58.00	26.31
2.00	50.8	3912	G, H & J	5.38	136.7	4.88	124.0	23.56	598.4	9.31	236.5	6.00	152.4	57.00	25.85	60.00	27.22
2.00	50.8	3914	G, H & J	6.56	166.6	6.75	171.5	24.75	628.7	9.31	236.5	6.00	152.4	80.00	36.29	83.00	37.65
2.00	50.8	3916	G, H & J	6.56	166.6	6.75	171.5	24.75	628.7	9.31	236.5	6.00	152.4	80.00	36.29	83.00	37.65
2.00	50.8	3918	G, H & J	7.00	177.8	6.75	171.5	25.19	639.8	9.31	236.5	6.00	152.4	106.00	48.08	109.00	49.44
3.00	76.2	3905	J, K & L	6.13	155.7	6.38	162.1	25.13	638.3	9.75	247.7	6.44	163.6	80.00	36.29	83.00	37.65
3.00	76.2	3910	J, K & L	6.13	155.7	6.38	162.1	25.13	638.3	9.75	247.7	6.44	163.6	83.00	37.65	86.00	39.01
3.00	76.2	3912	J, K & L	6.38	162.1	6.38	162.1	25.38	644.7	9.75	247.7	6.44	163.6	87.00	39.46	90.00	40.82
3.00	76.2	3914	J, K & L	7.50	190.5	7.13	181.1	26.81	681.0	9.81	249.2	6.50	165.1	140.00	63.50	143.00	64.86
3.00	76.2	3916	J, K & L	7.50	190.5	7.13	181.1	26.81	681.0	9.81	249.2	6.50	165.1	157.00	71.21	160.00	72.57
3.00	76.2	3918	J, K & L	8.75	222.3	9.00	228.6	28.06	712.7	11.69	296.9	8.38	212.9	185.00	83.91	188.00	85.28
3.00	76.2	3905	L, M, N & P	7.75	196.9	8.25	209.6	28.50	723.9	11.44	290.6	8.13	206.5	191.00	86.64	194.00	88.00
4.00	101.6	3910	L, M, N & P	7.75	196.9	8.25	209.6	28.50	723.9	11.44	290.6	8.13	206.5	199.00	90.26	202.00	91.63
4.00	101.6	3912	L, M, N & P	7.75	196.9	8.25	209.6	28.50	723.9	11.44	290.6	8.13	206.5	206.00	93.44	209.00	94.80
4.00	101.6	3914	L, M, N & P	9.81	249.2	9.19	233.4	31.06	788.9	11.38	289.1	8.06	204.7	240.00	108.86	243.00	110.22
4.00	101.6	3916	L, M, N & P	9.81	249.2	9.19	233.4	31.06	788.9	11.38	289.1	8.06	204.7	259.00	117.48	262.00	118.84
6.00	152.4	3905	Q & R	9.44	239.8	9.50	241.3	31.94	811.3	12.31	312.7	9.00	228.6	348.00	157.85	351.00	159.21
6.00	152.4	3910	Q & R	9.44	239.8	9.50	241.3	31.94	811.3	12.31	312.7	9.00	228.6	367.00	166.47	370.00	167.83
6.00	152.4	3912	Q & R	9.69	246.1	9.50	241.3	32.19	817.6	12.31	312.7	9.00	228.6	415.70	188.56	418.70	189.92
8.00	203.2	3905	T	10.88	276.4	11.00	279.4	35.44	900.2	13.25	336.6	9.94	252.5	516.70	234.37	519.70	235.73
8.00	203.2	3910	T	10.88	276.4	11.00	279.4	35.44	900.2	13.25	336.6	9.94	252.5	544.70	247.07	547.70	248.43
8.00	203.2	3912	T	11.69	296.9	11.00	279.4	36.25	920.8	13.25	336.6	9.94	252.5	601.00	272.61	604.00	273.97

# Dimensions and Weights

## 39MPV Series Type 39PV Pilot Full Bore

39PV with Single Outlet - Full Bore

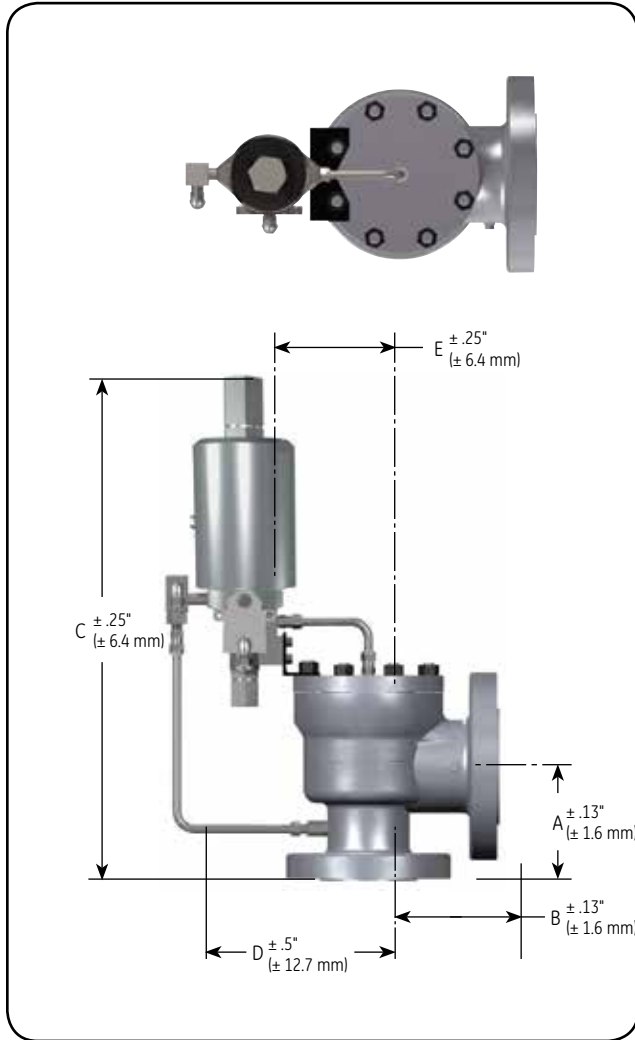

39PV with Double Outlet - Full Bore

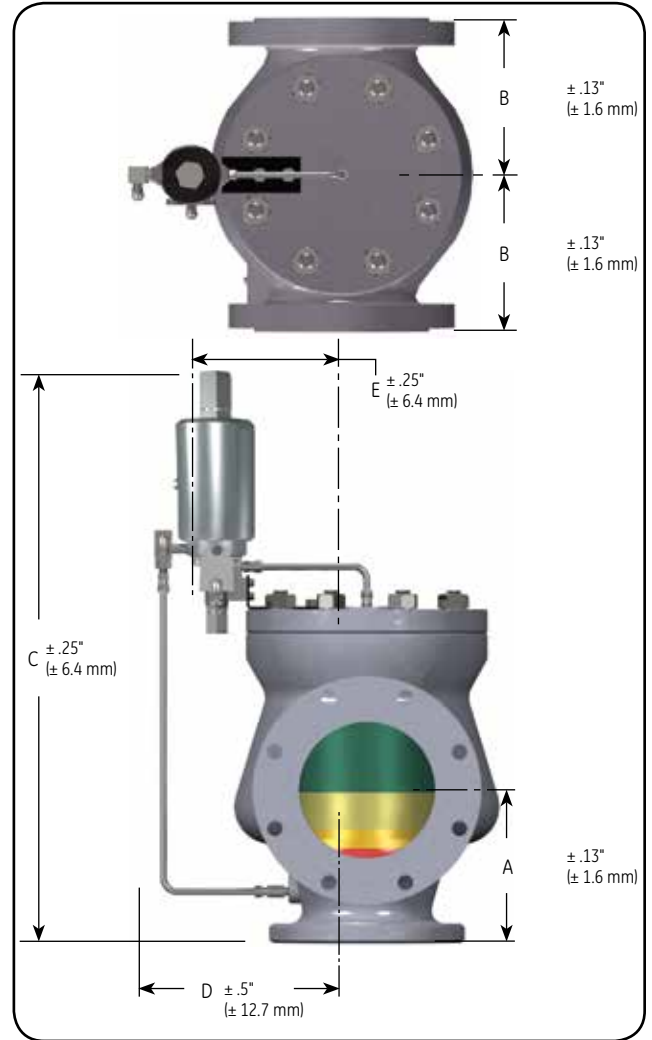

**Note:**

All weights listed in this document are approximations.

# Dimensions and Weights

## 39MPV Series Type 39MV Pilot Full Bore

39MV with Single Outlet - Full Bore

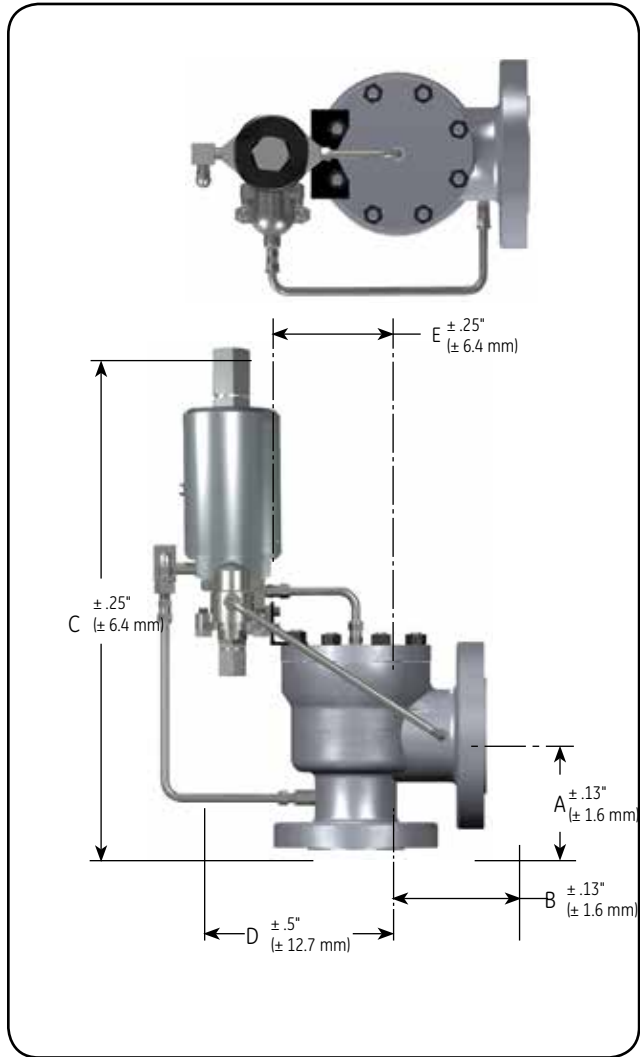

39MV with Double Outlet - Full Bore

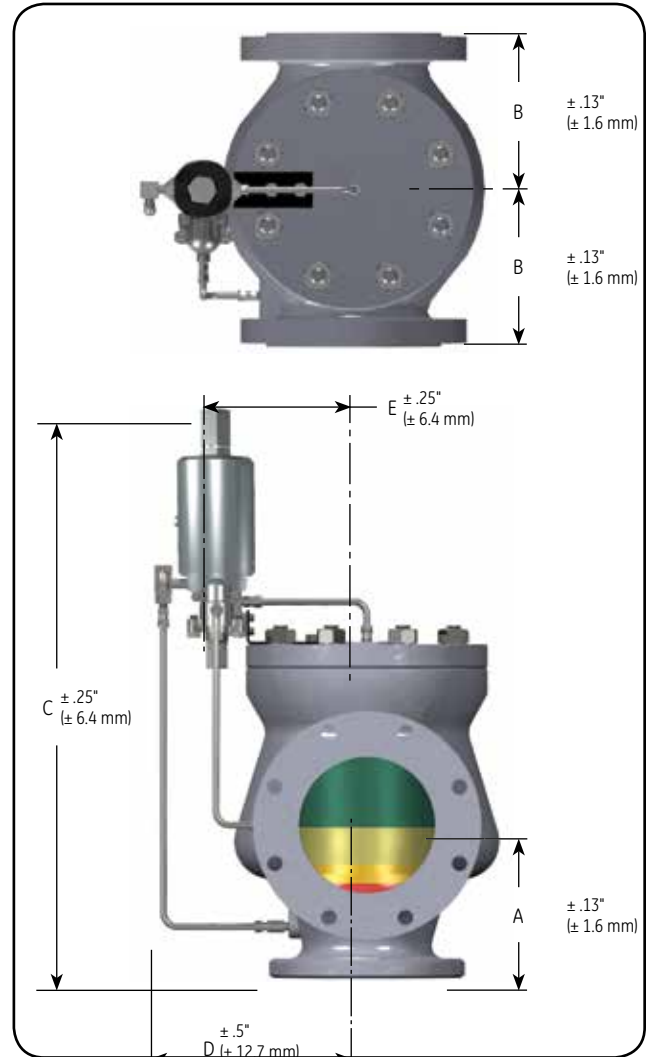

**Note:**  
All weights listed in this document are approximations.

# Dimensions and Weights

## 39MPV Series Type 39MV Single and Double Outlet, Full Bore

Full Bore Valve Overall Constructed Dimensions																			
Valve Inlet Size		Valve Type	Orifice (Full Bore)		Outlet Type	A		B		C		D		E		Approximate Weight			
						in	mm	in	mm	in	mm	in	mm	in	mm	PV Pilot		MV Pilot	
in	mm		in	mm		in	mm	in	mm	in	mm	in	mm	in	mm	lb	kg	lb	kg
3.00	76.2	3905B	3.00	76.2	Single	5.56	141.2	7.00	177.8	28.38	720.9	11.44	290.6	8.13	206.5	191	86.6	194	88.0
3.00	76.2	3910B	3.00	76.2	Single	5.81	147.6	7.00	177.8	28.63	727.2	11.44	290.6	8.13	206.5	199	90.3	202	91.6
3.00	76.2	3912B	3.00	76.2	Single	6.13	155.7	7.00	177.8	28.94	735.1	11.44	290.6	8.13	206.5	206	93.4	209	94.8
4.00	101.6	3905B	4.00	101.6	Single	6.94	176.3	7.38	187.5	28.69	728.7	11.44	290.6	8.13	206.5	191	86.6	194	88.0
4.00	101.6	3910B	4.00	101.6	Single	7.44	189.0	7.38	187.5	29.19	741.4	11.44	290.6	8.13	206.5	199	90.3	202	91.6
4.00	101.6	3912B	4.00	101.6	Single	7.94	201.7	7.38	187.5	29.69	754.1	11.44	290.6	8.13	206.5	206	93.4	209	94.8
6.00	152.4	3905B	6.00	152.4	Double	8.75	222.3	8.25	209.6	34.44	874.8	13.25	336.6	9.94	252.5	517	234.4	520	235.7
6.00	152.4	3910B	6.00	152.4	Double	9.31	236.5	8.25	209.6	34.88	886.0	13.25	336.6	9.94	252.5	545	247.1	548	248.4
6.00	152.4	3912B	6.00	152.4	Double	10.00	254.0	8.25	209.6	25.56	649.2	13.25	336.6	9.94	252.5	601	272.6	604	274.0
8.00	203.2	3905B	8.00	203.2	Double	10.25	260.4	11.06	280.9	37.63	955.8	14.63	371.6	11.31	287.3	975	442.3	978	443.7
8.00	203.2	3910B	8.00	203.2	Double	10.94	277.9	11.06	280.9	38.31	973.1	14.63	371.6	11.31	287.3	985	446.9	988	448.2
8.00	203.2	3912B	8.00	203.2	Double	11.43	290.3	11.06	280.9	39.13	993.9	14.63	371.6	11.31	287.3	1005	456.0	1008	457.3
10.00	254.0	3905XB	10.00	254.0	Single	12.06	306.3	13.75	349.3	42.19	1071.6	16.06	407.9	12.75	323.9	1100	499.0	1104	500.8
10.00	254.0	3910XB	10.00	254.0	Single	12.75	323.9	13.75	349.3	45.56	1157.2	16.06	407.9	12.75	323.9	1100	499.0	1104	500.8
10.00	254.0	3905B	10.00	254.0	Double	10.25	260.4	12.75	323.9	40.50	1028.7	16.06	407.9	12.75	323.9	1282	581.6	1285	583.0
10.00	254.0	3910B	10.00	254.0	Double	10.94	277.9	12.75	323.9	41.19	1046.2	16.06	407.9	12.75	323.9	1292	586.1	1295	587.5
12.00	304.8	3905XB	12.00	304.8	Single	11.94	303.3	15.56	395.2	44.84	1138.9	17.75	450.9	14.44	366.8	1860	843.7	1863	845.0
12.00	304.8	3910XB	12.00	304.8	Single	12.69	322.3	15.56	395.2	47.34	1202.4	17.75	450.9	14.44	366.8	1872	849.1	1875	850.5

**Note:**

For dimensions for 1.5" (38.1 mm) and 2.0" (50.8 mm) Full Bore valves, contact Dresser Applications Engineering.

# Pressure / Temperature

## Pressure - Temperature Rating Charts

Standard ASME SA216 WCC Carbon Steel Construction																
Valve Type	Inlet Pressure Class	Temperature [°F (°C)]														
		-20 to 100 (-28.9 to 37.8)		200 (93.3)		300(148.9)		400(204.4)		500(260.0)		600(315.6)		650(343.3)		
		psig	barg	psig	barg	psig	barg	psig	barg	psig	barg	psig	barg	psig	barg	
3905	150	290	19.99	260	17.92	230	15.85	200	13.78	170	11.72	140	9.65	125	8.61	
3910	300	750	51.71	750	51.71	730	50.33	705	48.60	665	45.85	605	41.71	590	40.67	
3912	600	1500	103.42	1500	103.42	1455	100.31	1405	96.87	1330	91.70	1210	83.42	1175	81.01	
3914	900	2250	155.13	2250	155.13	2185	150.65	2110	145.47	1995	137.55	1815	125.13	1765	121.69	
3916	1500	3750	258.55	3750	258.55	3640	250.96	3520	242.69	3325	229.25	3025	208.56	2940	202.70	
3918	2500	6250	430.92	6250	430.92	6070	418.51	5865	404.37	5540	381.96	5040	347.49	4905	338.18	

Standard ASME SA351 CF8M Steel Construction																	
Valve Type	Inlet Pressure Class	Temperature [°F (°C)]															
		-320(-195.6)		-20 to 100 (-28.9 to 37.8)		200 (93.3)		300(148.9)		400(204.4)		500(260.0)		600(315.6)		650(343.3)	
		psig	barg	psig	barg	psig	barg	psig	barg	psig	barg	psig	barg	psig	barg	psig	barg
3905	150	275	18.96	275	18.96	235	16.20	215	14.82	195	13.44	170	11.72	140	9.65	125	8.61
3910	300	720	49.64	720	49.64	620	42.74	560	38.61	515	35.50	480	33.09	450	31.02	440	30.33
3912	600	1440	99.28	1440	99.28	1240	85.49	1120	77.22	1025	70.67	955	65.84	900	62.05	885	61.01
3914	900	2160	148.92	2160	148.92	1860	128.24	1680	115.83	1540	106.17	1435	98.93	1355	93.42	1325	91.35
3916	1500	3600	248.21	3600	248.21	3095	213.39	2795	192.70	2570	177.19	2390	164.78	2255	155.47	2210	152.37
3918	2500	6000	413.68	6000	413.68	5160	355.76	4660	321.29	4280	295.09	3980	274.41	3760	259.24	3680	253.72



# Capacities - Air

## Valve Capacity for ASME B and PV Code Section VIII Standard Bore, for Air

Capacities Based at 10 percent overpressure or 3 psig (0.21 barg), whichever is greater, showing 90 percent actual capacity in accordance with latest ASME Code requirements. Units of ft<sup>3</sup> (m<sup>3</sup>) of air per minute @ 60°F (15.6°C).

Orifice Designation		D		E		F		G		H		J		K	
Orifice Area		in <sup>2</sup>	cm <sup>2</sup>	in <sup>2</sup>	cm <sup>2</sup>	in <sup>2</sup>	cm <sup>2</sup>	in <sup>2</sup>	cm <sup>2</sup>	in <sup>2</sup>	cm <sup>2</sup>	in <sup>2</sup>	cm <sup>2</sup>	in <sup>2</sup>	cm <sup>2</sup>
Set Pressure		Orifice Capacity													
psig	barg	ft <sup>3</sup> /min	m <sup>3</sup> /min	ft <sup>3</sup> /min	m <sup>3</sup> /min	ft <sup>3</sup> /min	m <sup>3</sup> /min	ft <sup>3</sup> /min	m <sup>3</sup> /min	ft <sup>3</sup> /min	m <sup>3</sup> /min	ft <sup>3</sup> /min	m <sup>3</sup> /min	ft <sup>3</sup> /min	m <sup>3</sup> /min
15	1.03	67	1	120	3	188	5	308	8	480	13	788	22	1126	31
20	1.37	77	2	138	3	216	6	355	10	554	15	908	25	1298	36
30	2.06	98	2	175	4	274	7	449	12	701	19	1149	32	1643	46
40	2.75	120	3	215	6	337	9	553	15	863	24	1415	40	2022	57
50	3.44	143	4	255	7	400	11	656	18	1025	29	1680	47	2401	67
60	4.13	166	4	296	8	464	13	760	21	1186	33	1945	55	2780	78
70	4.82	189	5	336	9	527	14	864	24	1348	38	2210	62	3159	89
80	5.51	211	5	377	10	590	16	968	27	1510	42	2475	70	3538	100
90	6.20	234	6	417	11	653	18	1071	30	1672	47	2741	77	3917	110
100	6.89	257	7	457	12	717	20	1175	33	1834	51	3006	85	4296	121
120	8.27	302	8	538	15	843	23	1382	39	2157	61	3536	100	5054	143
140	9.65	347	9	619	17	970	27	1590	45	2481	70	4067	115	5812	164
160	11.03	393	11	700	19	1096	31	1797	50	2804	79	4597	130	6570	186
180	12.41	438	12	781	22	1223	34	2004	56	3128	88	5127	145	7328	207
200	13.78	483	13	861	24	1349	38	2212	62	3452	97	5658	160	8086	228
220	15.16	529	14	942	26	1476	41	2419	68	3775	106	6188	175	8844	250
240	16.54	574	16	1023	28	1602	45	2627	74	4099	116	6719	190	9602	271
260	17.92	619	17	1104	31	1729	48	2834	80	4422	125	7249	205	10360	293
280	19.30	665	18	1185	33	1855	52	3041	86	4746	134	7779	220	11118	314
300	20.68	710	20	1265	35	1982	56	3249	92	5070	143	8310	235	11876	336
320	22.06	755	21	1346	38	2108	59	3456	97	5393	152	8840	250	12634	357
340	23.44	801	22	1427	40	2235	63	3663	103	5717	161	9371	265	13392	379
360	24.82	846	23	1508	42	2361	66	3871	109	6040	171	9901	280	14150	400
380	26.20	891	25	1589	44	2488	70	4078	115	6364	180	10431	295	14908	422
400	27.57	937	26	1669	47	2614	74	4285	121	6687	189	10962	310	15666	443
420	28.95	982	27	1750	49	2741	77	4493	127	7011	198	11492	325	16424	465
440	30.33	1027	29	1831	51	2867	81	4700	133	7335	207	12022	340	17182	486
460	31.71	1073	30	1912	54	2994	84	4908	138	7658	216	12553	355	17940	508
480	33.09	1118	31	1993	56	3120	88	5115	144	7982	226	13083	370	18698	529
500	34.47	1163	32	2073	58	3247	91	5322	150	8305	235	13614	385	19456	550
600	41.36	1390	39	2477	70	3879	109	6359	180	9923	280	16266	460	23246	658
700	48.26	1617	45	2881	81	4512	127	7396	209	11541	326	18918	535	27036	765
750	51.71	1730	48	3083	87	4828	136	7914	224	12350	349	20244	573	28931	819
800	55.15	1844	52	3285	93	5144	145	8433	238	13159	372	21570	610	30826	872
900	62.05	2070	58	3689	104	5777	163	9470	268	14777	418	24221	685	34616	980
1000	68.94	2297	65	4093	115	6409	181	10507	297	16395	464	26873	760	38406	1087
1100	75.84	2524	71	4497	127	7042	199	11543	326	18013	510	29525	836	42196	1194
1200	82.73	2751	77	4901	138	7674	217	12580	356	19631	555	32177	911	45986	1302
1300	89.63	2977	84	5305	150	8307	235	13617	385	21249	601	34829	986	49776	1409
1400	96.52	3204	90	5709	161	8939	253	14654	414	22867	647	37481	1061	53566	1516
1500	103.42	3431	97	6113	173	9571	271	15691	444	24485	693	40133	1136	57356	1624
1600	110.31	3657	103	6517	184	10204	288	16728	473	26103	739	42785	1211	61146	1731
1700	117.21	3884	109	6921	195	10836	306	17765	503	27721	784	45437	1286	64936	1838
1800	124.10	4111	116	7325	207	11469	324	18801	532	29339	830	48089	1361	68726	1946
1900	131.00	4338	122	7729	218	12101	342	19838	561	30957	876	50741	1436	72516	2053
2000	137.89	4564	129	8133	230	12734	360	20875	591	32575	922	53393	1511	76307	2160
2500	172.36	5698	161	10153	287	15896	450	26059	737	40664	1151	66653	1887	95257	2697
3000	206.84	6832	193	12173	344	19059	539	31244	884	48754	1380	79913	2262	114207	3233
3750	258.55	8532	241	15203	430	23803	674	39020	1104	60888	1724	99802	2826	142632	4038
4000	275.79	9099	257	16213	459	25384	718	41612	1178	64933	1838	106432	3013	152107	4307
4250	293.02	9666	273	17223	487	26965	763	44204	1251	68978	1953	113062	3201	161582	4575
4500	310.26	10233	289	18233	516	28546	808	46796	1325	73023	2067	119692	3389	171057	4843
4750	327.50	10799	305	19243	544	30128	853	49388	1398	77068	2182	126322	3577	180532	5112
5000	344.73	11366	321	20253	573	31709	897	51981	1471	81113	2296	132952	3764	190007	5380
5250	361.97	11933	337	21263	602	33290	942	54573	1545	85158	2411	139582	3952	199482	5648
5500	379.21	12500	353	22273	630	34871	987	57165	1618	89202	2525	146211	4140	208957	5917
5750	396.44	13067	370	23283	659	36453	1032	59757	1692	93247	2640	152841	4327	218432	6185
6000	413.68	13633	386	24293	687	38034	1077	62349	1765	97292	2755	159471	4515	227908	6453
6250	430.92	14200	402	25303	716	39615	1121	64941	1838	101337	2869	166101	4703	237383	6721

# Capacities - Air

## Valve Capacity for ASME B and P V Code Section VIII Standard Bore, for Air

Capacities Based at 10 percent overpressure or 3 psig (0.21 barg), whichever is greater, showing 90 percent actual capacity in accordance with latest ASME Code requirements. Units of ft<sup>3</sup> (m<sup>3</sup>) of air per minute @ 60°F (15.6°C).

Orifice Designation		L		M		N		P		Q		R		T	
Orifice Area		in <sup>2</sup>	cm <sup>2</sup>	in <sup>2</sup>	cm <sup>2</sup>	in <sup>2</sup>	cm <sup>2</sup>	in <sup>2</sup>	cm <sup>2</sup>	in <sup>2</sup>	cm <sup>2</sup>	in <sup>2</sup>	cm <sup>2</sup>	in <sup>2</sup>	cm <sup>2</sup>
Set Pressure		Orifice Capacity													
psig	barg	ft <sup>3</sup> /min	m <sup>3</sup> /min	ft <sup>3</sup> /min	m <sup>3</sup> /min	ft <sup>3</sup> /min	m <sup>3</sup> /min	ft <sup>3</sup> /min	m <sup>3</sup> /min	ft <sup>3</sup> /min	m <sup>3</sup> /min	ft <sup>3</sup> /min	m <sup>3</sup> /min	ft <sup>3</sup> /min	m <sup>3</sup> /min
15	1.03	1747	49	2205	62	2659	75	3908	110	6771	191	9801	277	15919	450
20	1.37	2015	57	2543	72	3066	86	4506	127	7807	221	11300	319	18354	519
30	2.06	2549	72	3217	91	3879	109	5701	161	9877	279	14297	404	23222	657
40	2.75	3137	88	3959	112	4774	135	7016	198	12155	344	17595	498	28577	809
50	3.44	3725	105	4701	133	5669	160	8331	235	14433	408	20892	591	33933	960
60	4.13	4313	122	5443	154	6563	185	9645	273	16711	473	24189	684	39288	1112
70	4.82	4901	138	6186	175	7458	211	10960	310	18989	537	27486	778	44643	1264
80	5.51	5489	155	6928	196	8353	236	12275	347	21267	602	30784	871	49999	1415
90	6.20	6077	172	7670	217	9247	261	13590	384	23545	666	34081	965	55354	1567
100	6.89	6665	188	8412	238	10142	287	14905	422	25823	731	37378	1058	60709	1719
120	8.27	7841	222	9896	280	11931	337	17534	496	30379	860	43972	1245	71420	2022
140	9.65	9017	255	11380	322	13721	388	20164	570	34934	989	50567	1431	82131	2325
160	11.03	10193	288	12864	364	15510	439	22794	645	39490	1118	57161	1618	92841	2628
180	12.41	11369	321	14348	406	17299	489	25423	719	44046	1247	63756	1805	103552	2932
200	13.78	12545	355	15832	448	19089	540	28053	794	48602	1376	70350	1992	114262	3235
220	15.16	13721	388	17316	490	20878	591	30682	868	53158	1505	76945	2178	124973	3538
240	16.54	14897	421	18800	532	22667	641	33312	943	57714	1634	83539	2365	135684	3842
260	17.92	16073	455	20284	574	24457	692	35942	1017	62269	1763	90133	2552	146394	4145
280	19.30	17249	488	21769	616	26246	743	38571	1092	66825	1892	96728	2739	157105	4448
300	20.68	18425	521	23253	658	28036	793	41201	1166	71381	2021	103322	2925	167816	4752
320	22.06	19601	555	24737	700	29825	844	43830	1241	75937	2150	109917	3112	178526	5055
340	23.44	20777	588	26221	742	31614	895	46460	1315	80493	2279	116511	3299	189237	5358
360	24.82	21953	621	27705	784	33404	945	49090	1390	85049	2408	123106	3485	199948	5661
380	26.20	23129	654	29189	826	35193	996	51719	1464	89604	2537	129700	3672	210658	5965
400	27.57	24305	688	30673	868	36982	1047	54349	1538	94160	2666	136294	3859	221369	6268
420	28.95	25481	721	32157	910	38772	1097	56979	1613	98716	2795	142889	4046	232079	6571
440	30.33	26657	754	33641	952	40561	1148	59608	1687	103272	2924	149483	4232	242790	6875
460	31.71	27833	788	35125	994	42350	1199	62238	1762	107828	3053	156078	4419	253501	7178
480	33.09	29009	821	36610	1036	44140	1249	64867	1836	112384	3182	162672	4606	264211	7481
500	34.47	30185	854	38094	1078	45929	1300	67497	1911	116939	3311	169267	4793	274922	7784
600	41.36	36066	1021	45514	1288	54876	1553	80645	2283	139719	3956	202239	5726	328475	9301
700	48.26	41946	1187	52935	1498	63823	1807	93793	2655	162498	4601	235211	6660	382028	10817
750	51.71	44886	1271	56645	1604	68296	1933	100367	2842	173887	4923	251697	7127	408805	11576
800	55.15	47826	1354	60355	1709	72770	2060	106941	3028	185277	5246	268183	7594	435582	12334
900	62.05	53706	1520	67776	1919	81716	2313	120089	3400	208056	5891	301155	8527	489135	13850
1000	68.94	59586	1687	75196	2129	90663	2567	133237	3772	230835	6536	334127	9461	542688	15367
1100	75.84	65466	1853	82617	2339	99610	2820	146386	4145	253614	7181	367100	10395	596241	16883
1200	82.73	71346	2020	90037	2549	108557	3073	159534	4517	276393	7826	400072	11328	649794	18400
1300	89.63	77226	2186	97458	2759	117504	3327	172682	4889	299173	8471	433044	12262	703347	19916
1400	96.52	83106	2353	104878	2969	126450	3580	185830	5262	321952	9116	466016	13196	756901	21433
1500	103.42	88986	2519	112299	3179	135397	3834	198978	5634	344731	9761	498988	14129	810454	22949
1600	110.31	94866	2686	119719	3390	144344	4087	212126	6006	—	—	—	—	—	—
1700	117.21	100746	2852	127140	3600	153291	4340	225274	6379	—	—	—	—	—	—
1800	124.10	106626	3019	134560	3810	162238	4594	238422	6751	—	—	—	—	—	—
1900	131.00	112506	3185	141981	4020	171184	4847	251570	7123	—	—	—	—	—	—
2000	137.89	118386	3352	149401	4230	180131	5100	264718	7495	—	—	—	—	—	—
2500	172.36	147786	4184	186504	5281	224865	6367	330459	9357	—	—	—	—	—	—
3000	206.84	177186	5017	223606	6331	269599	7634	396199	11219	—	—	—	—	—	—
3750	258.55	221287	6266	279260	7907	336700	9534	494810	14011	—	—	—	—	—	—
4000	275.79	235987	6682	—	—	—	—	—	—	—	—	—	—	—	—
4250	293.02	250687	7098	—	—	—	—	—	—	—	—	—	—	—	—
4500	310.26	265387	7514	—	—	—	—	—	—	—	—	—	—	—	—
4750	327.50	280087	7931	—	—	—	—	—	—	—	—	—	—	—	—
5000	344.73	294787	8347	—	—	—	—	—	—	—	—	—	—	—	—
5250	361.97	309487	8763	—	—	—	—	—	—	—	—	—	—	—	—
5500	379.21	324187	9179	—	—	—	—	—	—	—	—	—	—	—	—
5750	396.44	338887	9596	—	—	—	—	—	—	—	—	—	—	—	—
6000	413.68	353587	10012	—	—	—	—	—	—	—	—	—	—	—	—
6250	430.92	368288	10428	—	—	—	—	—	—	—	—	—	—	—	—

# Capacities - Air

## Valve Capacity for ASME B and PV Code Section VIII - Full Bore, for Air

Capacities Based at 10 percent overpressure or 3 psig (0.21 barg), whichever is greater, showing 90 percent actual capacity in accordance with latest ASME Code requirements. Units of ft<sup>3</sup> (m<sup>3</sup>) of air per minute @ 60°F (15.6°C).

Orifice Designation		1.5" (38.1 mm) FB		2" (50.8 mm) FB		3" (76.2 mm) FB		4" (101.6 mm) FB		6" (152.4 mm) FB		8" (203.2 mm) FB		10" (254 mm) FB		12" (304.80 mm) FB	
Orifice Area		in <sup>2</sup>	cm <sup>2</sup>	in <sup>2</sup>	cm <sup>2</sup>	in <sup>2</sup>	cm <sup>2</sup>	in <sup>2</sup>	cm <sup>2</sup>	in <sup>2</sup>	cm <sup>2</sup>	in <sup>2</sup>	cm <sup>2</sup>	in <sup>2</sup>	cm <sup>2</sup>	in <sup>2</sup>	cm <sup>2</sup>
Set Pressure		Orifice Capacity															
psig	barg	ft <sup>3</sup> /min	m <sup>3</sup> /min	ft <sup>3</sup> /min	m <sup>3</sup> /min	ft <sup>3</sup> /min	m <sup>3</sup> /min	ft <sup>3</sup> /min	m <sup>3</sup> /min	ft <sup>3</sup> /min	m <sup>3</sup> /min	ft <sup>3</sup> /min	m <sup>3</sup> /min	ft <sup>3</sup> /min	m <sup>3</sup> /min	ft <sup>3</sup> /min	m <sup>3</sup> /min
15	1.03	854	24	1456	41	3331	94	5670	160	13148	372	23281	659	36856	1043	59252	1677
20	1.37	985	27	1679	47	3840	108	6537	185	15158	429	26841	760	42492	1203	68313	1934
30	2.06	1246	35	2124	60	4858	137	8271	234	19179	543	33961	961	53763	1522	86433	2447
40	2.75	1534	43	2614	74	5979	169	10178	288	23602	668	41793	1183	66161	1873	106365	3011
50	3.44	1821	51	3104	87	7100	201	12086	342	28024	793	49624	1405	78559	2224	126297	3576
60	4.13	2109	59	3594	101	8220	232	13993	396	32447	918	57456	1626	90958	2575	146229	4140
70	4.82	2396	67	4084	115	9341	264	15900	450	36870	1044	65288	1848	103356	2926	166162	4705
80	5.51	2684	76	4574	129	10461	296	17808	504	41293	1169	73120	2070	115754	3277	186094	5269
90	6.20	2972	84	5064	143	11582	327	19715	558	45716	1294	80952	2292	128152	3628	206026	5834
100	6.89	3259	92	5554	157	12702	359	21623	612	50139	1419	88783	2514	140550	3979	225958	6398
120	8.27	3834	108	6534	185	14943	423	25438	720	58985	1670	104447	2957	165347	4682	265822	7527
140	9.65	4409	124	7514	212	17184	486	29252	828	67830	1920	120110	3401	190143	5384	305687	8656
160	11.03	4984	141	8494	240	19425	550	33067	936	76676	2171	135774	3844	214940	6086	345551	9784
180	12.41	5559	157	9474	268	21666	613	36882	1044	85522	2421	151438	4288	239736	6788	385416	10913
200	13.78	6134	173	10454	296	23907	676	40697	1152	94368	2672	167101	4731	264533	7490	425280	12042
220	15.16	6709	189	11434	323	26148	740	44512	1260	103213	2922	182765	5175	289329	8192	465144	13171
240	16.54	7285	206	12414	351	28389	803	48327	1368	112059	3173	198428	5618	314126	8895	505009	14300
260	17.92	7860	222	13394	379	30630	867	52141	1476	120905	3423	214092	6062	338922	9597	544873	15429
280	19.30	8435	238	14374	407	32872	930	55956	1584	129751	3674	229755	6505	363719	10299	584738	16557
300	20.68	9010	255	15353	434	35113	994	59771	1692	138596	3924	245419	6949	388515	11001	624602	17686
320	22.06	9585	271	16333	462	37354	1057	63586	1800	147442	4175	261082	7393	413312	11703	664466	18815
340	23.44	10160	287	17313	490	39595	1121	67401	1908	156288	4425	276746	7836	438108	12405	704331	19944
360	24.82	10735	303	18293	518	41836	1184	71216	2016	165134	4676	292410	8280	462905	13108	744195	21073
380	26.20	11310	320	19273	545	44077	1248	75031	2124	173979	4926	308073	8723	487701	13810	784059	22202
400	27.57	11885	336	20253	573	46318	1311	78845	2232	182825	5177	323737	9167	512498	14512	823924	23330
420	28.95	12460	352	21233	601	48559	1375	82660	2340	191671	5427	339400	9610	537294	15214	863788	24459
440	30.33	13035	369	22213	629	50800	1438	86475	2448	200517	5678	355064	10054	562091	15916	903653	25588
460	31.71	13610	385	23193	656	53041	1501	90290	2556	209363	5928	370727	10497	586887	16618	943517	26717
480	33.09	14185	401	24173	684	55282	1565	94105	2664	218208	6178	386391	10941	611684	17320	983381	27846
500	34.47	14760	417	25153	712	57523	1628	97920	2772	227054	6429	402054	11384	636480	18023	1023246	28975
600	41.36	17636	499	30053	851	68728	1946	116994	3312	271283	7681	480372	13602	760463	21533	1222568	34619
700	48.26	20511	580	34952	989	79933	2263	136068	3853	315512	8934	558690	15820	884445	25044	1421890	40263
750	51.71	21949	621	37402	1059	85536	2422	145605	4123	337626	9560	597849	16929	946436	26800	1521551	43085
800	55.15	23386	662	39852	1128	91139	2580	155142	4393	359740	10186	637008	18038	—	—	—	—
900	62.05	26262	743	44752	1267	102344	2898	174216	4933	403969	11439	715325	20255	—	—	—	—
1000	68.94	29137	825	49652	1405	113549	3215	193291	5473	448198	12691	793643	22473	—	—	—	—
1100	75.84	32012	906	54551	1544	124754	3532	212365	6013	492427	13943	871961	24691	—	—	—	—
1200	82.73	34888	987	59451	1683	135960	3849	231439	6553	536656	15196	950279	26908	—	—	—	—
1300	89.63	37763	1069	64351	1822	147165	4167	250513	7093	580884	16448	1028596	29126	—	—	—	—
1400	96.52	40638	1150	69251	1960	158370	4484	269588	7633	625113	17701	1106914	31344	—	—	—	—
1500	103.42	43513	1232	74150	2099	169575	4801	288662	8173	669342	18953	1185232	33562	—	—	—	—
1600	110.31	46389	1313	79050	2238	180780	5119	307736	8714	—	—	—	—	—	—	—	—
1700	117.21	49264	1395	83950	2377	191986	5436	326810	9254	—	—	—	—	—	—	—	—
1800	124.10	52139	1476	88850	2515	203191	5753	345884	9794	—	—	—	—	—	—	—	—
1900	131.00	55015	1557	93749	2654	214396	6071	364959	10334	—	—	—	—	—	—	—	—
2000	137.89	57890	1639	98649	2793	225601	6388	384033	10874	—	—	—	—	—	—	—	—
2500	172.36	72267	2046	123148	3487	281627	7974	479404	13575	—	—	—	—	—	—	—	—
3000	206.84	86643	2453	147646	4180	337653	9561	574775	16275	—	—	—	—	—	—	—	—
3750	258.55	108208	3064	184394	5221	421693	11941	717832	20326	—	—	—	—	—	—	—	—
4000	275.79	115396	3267	196644	5568	449706	12734	765517	21677	—	—	—	—	—	—	—	—
4250	293.02	122585	3471	208893	5915	477719	13527	813203	23027	—	—	—	—	—	—	—	—
4500	310.26	129773	3674	221142	6262	505732	14320	860888	24377	—	—	—	—	—	—	—	—
4750	327.50	136961	3878	233392	6608	533745	15113	908574	25727	—	—	—	—	—	—	—	—
5000	344.73	144149	4081	245641	6955	561758	15907	956259	27078	—	—	—	—	—	—	—	—
5250	361.97	151338	4285	257890	7302	589771	16700	1003945	28428	—	—	—	—	—	—	—	—
5500	379.21	158526	4488	270140	7649	617784	17493	1051631	29778	—	—	—	—	—	—	—	—
5750	396.44	165714	4692	282389	7996	645797	18286	1099316	31129	—	—	—	—	—	—	—	—
6000	413.68	172903	4896	294638	8343	673810	19080	1147002	32479	—	—	—	—	—	—	—	—
6250	430.92	180091	5099	306888	8690	701823	19873	1194687	33829	—	—	—	—	—	—	—	—

# Capacities - Water

## Valve Capacity for ASME B and PV Code Section VIII - Standard Bore, for Water

Capacities Based at 10 percent overpressure or 3 psig (0.21 barg), whichever is greater, showing 90 percent actual capacity in accordance with latest ASME Code requirements.

Orifice Designation		D		E		F		G		H		J		K	
Orifice Area		in <sup>2</sup>	cm <sup>2</sup>	in <sup>2</sup>	cm <sup>2</sup>	in <sup>2</sup>	cm <sup>2</sup>	in <sup>2</sup>	cm <sup>2</sup>	in <sup>2</sup>	cm <sup>2</sup>	in <sup>2</sup>	cm <sup>2</sup>	in <sup>2</sup>	cm <sup>2</sup>
Set Pressure		Orifice Capacity													
psig	barg	gpm	L/min	gpm	L/min	gpm	L/min	gpm	L/min	gpm	L/min	gpm	L/min	gpm	L/min
15	1.03	15	56	27	102	42	158	70	264	109	412	179	677	256	969
20	1.37	17	64	30	113	48	181	79	299	123	465	202	764	289	1093
30	2.06	20	75	36	136	57	215	94	355	148	560	242	916	346	1309
40	2.75	23	87	42	158	66	249	109	412	170	643	280	1059	400	1514
50	3.44	26	98	47	177	74	280	122	461	191	723	313	1184	447	1692
60	4.13	29	109	52	196	81	306	134	507	209	791	343	1298	490	1854
70	4.82	31	117	56	211	88	333	144	545	226	855	370	1400	529	2002
80	5.51	33	124	60	227	94	355	154	582	241	912	396	1499	566	2142
90	6.20	35	132	64	242	100	378	164	620	256	969	420	1589	600	2271
100	6.89	37	140	67	253	105	397	173	654	270	1022	442	1673	633	2396
120	8.27	41	155	73	276	115	435	189	715	296	1120	485	1835	693	2623
140	9.65	44	166	79	299	125	473	204	772	319	1207	524	1983	749	2835
160	11.03	47	177	85	321	133	503	219	829	341	1290	560	2119	800	3028
180	12.41	50	189	90	340	141	533	232	878	362	1370	594	2248	849	3213
200	13.78	53	200	95	359	149	564	244	923	382	1446	626	2369	895	3387
220	15.16	56	211	100	378	156	590	256	969	400	1514	657	2487	939	3554
240	16.54	58	219	104	393	163	617	268	1014	418	1582	686	2596	980	3709
260	17.92	61	230	108	408	170	643	279	1056	435	1646	714	2702	1020	3861
280	19.30	63	238	112	423	176	666	289	1093	452	1711	741	2804	1059	4008
300	20.68	65	246	116	439	182	688	299	1131	468	1771	767	2903	1096	4148
320	22.06	67	253	120	454	188	711	309	1169	483	1828	792	2998	1132	4285
340	23.44	69	261	124	469	194	734	319	1207	498	1885	816	3088	1167	4417
360	24.82	71	268	128	484	200	757	328	1241	512	1938	840	3179	1201	4546
380	26.20	73	276	131	495	205	776	337	1275	526	1991	863	3266	1234	4671
400	27.57	75	283	134	507	211	798	346	1309	540	2044	885	3350	1266	4792
420	28.95	77	291	138	522	216	817	354	1340	553	2093	907	3433	1297	4909
440	30.33	79	299	141	533	221	836	363	1374	566	2142	929	3516	1327	5023
460	31.71	81	306	144	545	226	855	371	1404	579	2191	950	3596	1357	5136
480	33.09	82	310	147	556	231	874	379	1434	592	2240	970	3671	1387	5250
500	34.47	84	317	150	567	236	893	387	1464	604	2286	990	3747	1415	5356
600	41.36	92	348	165	624	258	976	424	1605	662	2505	1085	4107	1550	5867
700	48.26	100	378	178	673	279	1056	458	1733	715	2706	1172	4436	1674	6336
750	51.71	103	389	184	696	289	1093	474	1794	740	2801	1213	4591	1733	6560
800	55.15	107	405	190	719	298	1128	489	1851	764	2892	1252	4739	1790	6775
900	62.05	113	427	202	764	316	1196	519	1964	810	3066	1328	5027	1899	7188
1000	68.94	119	450	213	806	334	1264	547	2070	854	3232	1400	5299	2001	7574
1100	75.84	125	473	223	844	350	1324	574	2172	896	3391	1469	5560	2099	7945
1200	82.73	131	495	233	882	365	1381	599	2267	936	3543	1534	5806	2193	8301
1300	89.63	136	514	243	919	380	1438	624	2362	974	3686	1597	6045	2282	8638
1400	96.52	141	533	252	953	395	1495	648	2452	1011	3827	1657	6272	2368	8963
1500	103.42	146	552	261	987	409	1548	670	2536	1046	3959	1715	6491	2451	9278
1600	110.31	151	571	269	1018	422	1597	692	2619	1081	4092	1771	6703	2532	9584
1700	117.21	156	590	278	1052	435	1646	714	2702	1114	4216	1826	6912	2610	9879
1800	124.10	160	605	286	1082	448	1695	734	2778	1146	4338	1879	7112	2685	10163
1900	131.00	165	624	294	1112	460	1741	754	2854	1178	4459	1930	7305	2759	10443
2000	137.89	169	639	301	1139	472	1786	774	2929	1208	4572	1981	7498	2831	10716
2500	172.36	189	715	337	1275	528	1998	865	3274	1351	5114	2214	8380	3165	11980
3000	206.84	207	783	369	1396	578	2187	948	3588	1480	5602	2426	9183	3467	13124
3750	258.55	231	874	413	1563	646	2445	1060	4012	1655	6264	2712	10266	3876	14672
4000	275.79	239	904	426	1612	668	2528	1095	4145	1709	6469	2801	10602	4003	15153
4250	293.02	246	931	439	1661	688	2604	1129	4273	1761	6666	2887	10928	4127	15622
4500	310.26	254	961	452	1711	708	2680	1161	4394	1812	6859	2971	11246	4246	16072
4750	327.50	261	987	465	1760	728	2755	1193	4515	1862	7048	3053	11556	4363	16515
5000	344.73	267	1010	477	1805	747	2827	1224	4633	1911	7233	3132	11855	4476	16943
5250	361.97	274	1037	488	1847	765	2895	1254	4746	1958	7411	3209	12147	4587	17363
5500	379.21	280	1059	500	1892	783	2963	1284	4860	2004	7585	3285	12435	4695	17772
5750	396.44	287	1086	511	1934	801	3032	1313	4970	2049	7756	3359	12715	4800	18169
6000	413.68	293	1109	522	1975	818	3096	1341	5076	2093	7922	3431	12987	4903	18559
6250	430.92	299	1131	533	2017	835	3160	1369	5182	2136	8085	3502	13256	5004	18942

# Capacities - Water

## Valve Capacity for ASME B and PV Code Section VIII - Standard Bore, for Water

Capacities Based at 10 percent overpressure or 3 psig (0.21 barg), whichever is greater, showing 90 percent actual capacity in accordance with latest ASME Code requirements.

Orifice Designation		L		M		N		P		Q		R		T	
		in <sup>2</sup>	cm <sup>2</sup>	in <sup>2</sup>	cm <sup>2</sup>	in <sup>2</sup>	cm <sup>2</sup>	in <sup>2</sup>	cm <sup>2</sup>	in <sup>2</sup>	cm <sup>2</sup>	in <sup>2</sup>	cm <sup>2</sup>	in <sup>2</sup>	cm <sup>2</sup>
Orifice Area		3.317	21.400	4.186	27.006	5.047	32.561	7.417	47.852	12.850	82.903	18.600	120.000	30.210	194.903
Set Pressure		Orifice Capacity													
psig	barg	gpm	L/min	gpm	L/min	gpm	L/min	gpm	L/min	gpm	L/min	gpm	L/min	gpm	L/min
15	1.03	397	1502	501	1896	604	2286	888	3361	1539	5825	2227	8430	3618	13695
20	1.37	449	1699	566	2142	683	2585	1004	3800	1739	6582	2518	9531	4090	15482
30	2.06	537	2032	678	2566	818	3096	1202	4550	2084	7888	3016	11416	4899	18544
40	2.75	621	2350	783	2963	945	3577	1389	5257	2406	9107	3483	13184	5657	21414
50	3.44	694	2627	876	3316	1056	3997	1552	5874	2690	10182	3894	14740	6325	23942
60	4.13	760	2876	960	3633	1157	4379	1701	6438	2947	11155	4266	16148	6929	26229
70	4.82	821	3107	1037	3925	1250	4731	1837	6953	3183	12048	4608	17443	7484	28330
80	5.51	878	3323	1108	4194	1336	5057	1964	7434	3403	12881	4926	18646	8001	30287
90	6.20	931	3524	1175	4447	1417	5363	2083	7885	3609	13661	5225	19778	8486	32123
100	6.89	982	3717	1239	4690	1494	5655	2196	8312	3805	14403	5507	20846	8945	33860
120	8.27	1075	4069	1357	5136	1637	6196	2405	9103	4168	15777	6033	22837	9799	37093
140	9.65	1162	4398	1466	5549	1768	6692	2598	9834	4502	17041	6516	24665	10584	40064
160	11.03	1242	4701	1567	5931	1890	7154	2778	10515	4813	18219	6966	26369	11315	42831
180	12.41	1317	4985	1662	6291	2005	7589	2946	11151	5104	19320	7389	27970	12001	45428
200	13.78	1389	5257	1752	6632	2113	7998	3105	11753	5381	20369	7789	29484	12650	47885
220	15.16	1456	5511	1838	6957	2216	8388	3257	12329	5643	21361	8169	30923	13268	50224
240	16.54	1521	5757	1920	7267	2315	8763	3402	12877	5894	22311	8532	32297	13858	52458
260	17.92	1583	5992	1998	7563	2409	9119	3541	13404	6135	23223	8880	33614	14424	54600
280	19.30	1643	6219	2074	7850	2500	9463	3675	13911	6367	24101	9216	34886	14968	56660
300	20.68	1701	6438	2146	8123	2588	9796	3804	14399	6590	24945	9539	36109	15494	58651
320	22.06	1757	6650	2217	8392	2673	10118	3928	14869	6806	25763	9852	37293	16002	60574
340	23.44	1811	6855	2285	8649	2755	10428	4049	15327	7016	26558	10155	38440	16494	62436
360	24.82	1863	7052	2351	8899	2835	10731	4167	15773	7219	27326	10450	39557	16972	64246
380	26.20	1914	7245	2416	9145	2913	11026	4281	16205	7417	28076	10736	40640	17438	66010
400	27.57	1964	7434	2479	9384	2988	11310	4392	16625	7610	28806	11015	41696	17891	67724
420	28.95	2012	7616	2540	9614	3062	11590	4500	17034	7798	29518	11287	42725	18332	69394
440	30.33	2060	7797	2600	9842	3134	11863	4606	17435	7981	30211	11552	43729	18764	71029
460	31.71	2106	7972	2658	10061	3205	12132	4710	17829	8160	30888	11812	44713	19186	72626
480	33.09	2151	8142	2715	10277	3274	12393	4811	18211	8336	31555	12066	45674	19598	74186
500	34.47	2196	8312	2771	10489	3341	12647	4910	18586	8508	32206	12315	46617	20002	75715
600	41.36	2405	9103	3036	11492	3660	13854	5379	20361	9320	35280	13490	51065	21911	82942
700	48.26	2598	9834	3279	12412	3954	14967	5810	21993	10067	38107	14571	55157	23667	89589
750	51.71	2689	10178	3394	12847	4092	15489	6014	22765	10420	39443	15083	57095	24498	92735
800	55.15	2778	10515	3505	13267	4227	16000	6211	23511	10762	40738	15578	58969	25301	95774
900	62.05	2946	11151	3718	14074	4483	16970	6588	24938	11415	43210	16523	62546	26836	101585
1000	68.94	3105	11753	3919	14835	4725	17886	6945	26289	12032	45546	17416	65926	28288	107081
1100	75.84	3257	12329	4111	15561	4956	18760	7284	27572	12619	47768	18266	69144	29668	112305
1200	82.73	3402	12877	4293	16250	5177	19597	7608	28799	13181	49895	19079	72221	30988	117302
1300	89.63	3541	13404	4469	16917	5388	20395	7918	29972	13719	51932	19858	75170	32253	122090
1400	96.52	3675	13911	4637	17552	5591	21164	8217	31104	14237	53892	20607	78005	33471	126701
1500	103.42	3804	14399	4800	18169	5788	21909	8506	32198	14736	55781	21331	80746	34645	131145
1600	110.31	3928	14869	4958	18768	5977	22625	8785	33254	-	-	-	-	-	-
1700	117.21	4049	15327	5110	19343	6161	23321	9055	34276	-	-	-	-	-	-
1800	124.10	4167	15773	5258	19903	6340	23999	9317	35268	-	-	-	-	-	-
1900	131.00	4281	16205	5402	20448	6514	24658	9573	36237	-	-	-	-	-	-
2000	137.89	4392	16625	5543	20982	6683	25297	9821	37176	-	-	-	-	-	-
2500	172.36	4911	18590	6197	23458	7472	28284	10981	41567	-	-	-	-	-	-
3000	206.84	5379	20361	6789	25699	8185	30983	12029	45534	-	-	-	-	-	-
3750	258.55	6014	22765	7590	28731	9151	34640	13449	50910	-	-	-	-	-	-
4000	275.79	6211	23511	-	-	-	-	-	-	-	-	-	-	-	-
4250	293.02	6403	24237	-	-	-	-	-	-	-	-	-	-	-	-
4500	310.26	6588	24938	-	-	-	-	-	-	-	-	-	-	-	-
4750	327.50	6769	25623	-	-	-	-	-	-	-	-	-	-	-	-
5000	344.73	6945	26289	-	-	-	-	-	-	-	-	-	-	-	-
5250	361.97	7116	26936	-	-	-	-	-	-	-	-	-	-	-	-
5500	379.21	7284	27572	-	-	-	-	-	-	-	-	-	-	-	-
5750	396.44	7447	28189	-	-	-	-	-	-	-	-	-	-	-	-
6000	413.68	7608	28799	-	-	-	-	-	-	-	-	-	-	-	-
6250	430.92	7764	29389	-	-	-	-	-	-	-	-	-	-	-	-

# Capacities - Water

## Valve Capacity for ASME B and PV Code Section VIII - Full Bore, for Water

Capacities Based at 10 percent overpressure or 3 psig (0.21 barg), whichever is greater, showing 90 percent actual capacity in accordance with latest ASME Code requirements.

Orifice Designation		1.5" (38.1 mm) FB		2" (50.8 mm) FB		3" (76.2 mm) FB		4" (101.6 mm) FB		6" (152.4 mm) FB		8" (203.2 mm) FB		10" (254 mm) FB		12" (304.80 mm) FB	
Orifice Area		in <sup>2</sup>	cm <sup>2</sup>	in <sup>2</sup>	cm <sup>2</sup>	in <sup>2</sup>	cm <sup>2</sup>	in <sup>2</sup>	cm <sup>2</sup>	in <sup>2</sup>	cm <sup>2</sup>	in <sup>2</sup>	cm <sup>2</sup>	in <sup>2</sup>	cm <sup>2</sup>	in <sup>2</sup>	cm <sup>2</sup>
Set Pressure		Orifice Capacity															
psig	barg	gpm	L/min	gpm	L/min	gpm	L/min	gpm	L/min	gpm	L/min	gpm	L/min	gpm	L/min	gpm	L/min
15	1.03	194	734	331	1252	757	2865	1288	4875	2988	11310	5292	20032	8377	31710	12288	46515
20	1.37	219	829	374	1415	855	3236	1456	5511	3378	12787	5982	22644	9469	35844	13890	52579
30	2.06	263	995	448	1695	1025	3880	1745	6605	4046	15315	7165	27122	11343	42937	16638	62981
40	2.75	303	1146	517	1957	1183	4478	2015	7627	4672	17685	8273	31316	13098	49581	19212	72725
50	3.44	339	1283	578	2187	1323	5008	2252	8524	5224	19774	9250	35015	14644	55433	21480	81310
60	4.13	372	1408	633	2396	1449	5485	2467	9338	5722	21660	10133	38357	16041	60721	23530	89070
70	4.82	401	1517	684	2589	1565	5924	2665	10088	6181	23397	10945	41431	17327	65589	25416	96210
80	5.51	429	1623	732	2770	1674	6336	2849	10784	6608	25014	11701	44293	18523	70117	27170	102849
90	6.20	455	1722	776	2937	1775	6719	3022	11439	7008	26528	12410	46976	19647	74371	28819	109091
100	6.89	480	1816	818	3096	1871	7082	3186	12060	7387	27962	13082	49520	20710	78395	30378	114993
120	8.27	526	1991	896	3391	2050	7760	3490	13211	8093	30635	14330	54244	22686	85875	33277	125967
140	9.65	568	2150	968	3664	2214	8380	3769	14267	8741	33088	15479	58594	24504	92757	35943	136059
160	11.03	607	2297	1035	3917	2367	8960	4030	15255	9345	35374	16547	62637	26196	99162	38425	145454
180	12.41	644	2437	1098	4156	2511	9505	4274	16178	9912	37521	17551	66437	27785	105177	40756	154278
200	13.78	679	2570	1157	4379	2647	10019	4505	17053	10448	39549	18501	70033	29288	110867	42961	162625
220	15.16	712	2695	1213	4591	2776	10508	4725	17886	10958	41480	19404	73452	30717	116276	45057	170559
240	16.54	744	2816	1267	4796	2899	10973	4935	18681	11445	43324	20266	76715	32083	121447	47061	178145
260	17.92	774	2929	1319	4992	3018	11424	5137	19445	11912	45091	21094	79849	33393	126406	48983	185420
280	19.30	803	3039	1369	5182	3131	11852	5331	20180	12362	46795	21890	82862	34654	131179	50832	192420
300	20.68	831	3145	1417	5363	3241	12268	5518	20887	12796	48438	22659	85773	35870	135782	52616	199173
320	22.06	859	3251	1464	5541	3348	12673	5699	21573	13216	50028	23402	88586	37047	140238	54341	205703
340	23.44	885	3350	1509	5712	3451	13063	5874	22235	13622	51564	24122	91311	38187	144553	56014	212036
360	24.82	911	3448	1552	5874	3551	13441	6045	22882	14017	53060	24821	93957	39294	148743	57638	218183
380	26.20	936	3543	1595	6037	3648	13809	6210	23507	14401	54513	25501	96531	40371	152820	59217	224160
400	27.57	960	3633	1636	6192	3743	14168	6372	24120	14775	55929	26164	99041	41420	156791	60756	229986
420	28.95	984	3724	1677	6348	3835	14517	6529	24714	15140	57311	26810	101486	42442	160660	62256	235664
440	30.33	1007	3811	1716	6495	3926	14861	6683	25297	15497	58662	27441	103875	43441	164442	63721	241210
460	31.71	1030	3898	1755	6643	4014	15194	6833	25865	15845	59979	28058	106211	44418	168140	65153	246630
480	33.09	1052	3982	1793	6787	4100	15520	6980	26422	16186	61270	28661	108493	45373	171755	66555	251938
500	34.47	1073	4061	1830	6927	4185	15841	7124	26967	16520	62535	29252	110730	46309	175298	67927	257131
600	41.36	1176	4451	2004	7585	4584	17352	7804	29541	18096	68500	32044	121299	50729	192030	74410	281672
700	48.26	1270	4807	2165	8195	4952	18745	8429	31907	19546	73989	34612	131020	54793	207414	80372	304241
750	51.71	1315	4977	2241	8483	5125	19400	8725	33027	20232	76586	35827	135619	56716	214693	83193	314919
800	55.15	1358	5140	2314	8759	5294	20039	9011	34110	20896	79099	37002	140067	—	—	—	—
900	62.05	1440	5450	2455	9293	5615	21255	9558	36180	22163	83896	39246	148562	—	—	—	—
1000	68.94	1518	5746	2588	9796	5918	22402	10075	38138	23362	88434	41369	156598	—	—	—	—
1100	75.84	1592	6026	2714	10273	6207	23496	10567	40000	24503	92753	43388	164241	—	—	—	—
1200	82.73	1663	6295	2835	10731	6483	24540	11037	41779	25592	96876	45318	171547	—	—	—	—
1300	89.63	1731	6552	2950	11166	6748	25543	11487	43483	26637	100832	47168	178550	—	—	—	—
1400	96.52	1797	6802	3062	11590	7003	26509	11921	45125	27643	104640	48949	185292	—	—	—	—
1500	103.42	1860	7040	3169	11995	7249	27440	12339	46708	28613	108311	50667	191795	—	—	—	—
1600	110.31	1921	7271	3273	12389	7486	28337	12744	48241	—	—	—	—	—	—	—	—
1700	117.21	1980	7495	3374	12771	7717	29212	13136	49725	—	—	—	—	—	—	—	—
1800	124.10	2037	7710	3472	13142	7941	30059	13517	51167	—	—	—	—	—	—	—	—
1900	131.00	2093	7922	3567	13502	8158	30881	13888	52571	—	—	—	—	—	—	—	—
2000	137.89	2147	8127	3660	13854	8370	31683	14248	53934	—	—	—	—	—	—	—	—
2500	172.36	2401	9088	4092	15489	9358	35423	15930	60301	—	—	—	—	—	—	—	—
3000	206.84	2630	9955	4482	16966	10251	38804	17451	66059	—	—	—	—	—	—	—	—
3750	258.55	2941	11132	5011	18968	11461	43384	19511	73857	—	—	—	—	—	—	—	—
4000	275.79	3037	11496	5176	19593	11837	44807	—	—	—	—	—	—	—	—	—	—
4250	293.02	3131	11852	5335	20195	12202	46189	—	—	—	—	—	—	—	—	—	—
4500	310.26	3221	12192	5490	20781	12555	47525	—	—	—	—	—	—	—	—	—	—
4750	327.50	3310	12529	5640	21349	12899	48828	—	—	—	—	—	—	—	—	—	—
5000	344.73	3396	12855	5787	21906	13235	50099	—	—	—	—	—	—	—	—	—	—
5250	361.97	3480	13173	5930	22447	13561	51333	—	—	—	—	—	—	—	—	—	—
5500	379.21	3561	13479	6069	22973	13881	52545	—	—	—	—	—	—	—	—	—	—
5750	396.44	3642	13786	6206	23492	14193	53726	—	—	—	—	—	—	—	—	—	—
6000	413.68	3720	14081	6339	23995	14498	54880	—	—	—	—	—	—	—	—	—	—
6250	430.92	3797	14373	6470	24491	14797	56012	—	—	—	—	—	—	—	—	—	—

# Capacities - Steam

## Valve Capacity for ASME B and PV Code Section VIII - Standard Bore, Saturated Steam

Capacities Based at 10 percent overpressure or 3 psig (0.21 barg), whichever is greater, showing 90 percent actual capacity in accordance with latest ASME Code requirements.

Orifice Designation		D		E		F		G		H		J		K	
		in <sup>2</sup>	cm <sup>2</sup>	in <sup>2</sup>	cm <sup>2</sup>	in <sup>2</sup>	cm <sup>2</sup>	in <sup>2</sup>	cm <sup>2</sup>	in <sup>2</sup>	cm <sup>2</sup>	in <sup>2</sup>	cm <sup>2</sup>	in <sup>2</sup>	cm <sup>2</sup>
Orifice Area		0.128	0.825	0.228	1.470	0.357	2.302	0.585	3.774	0.913	5.888	1.496	9.652	2.138	13.794
Set Pressure		Orifice Capacity													
psig	barg	lb/hr	kg/hr	lb/hr	kg/hr	lb/hr	kg/hr	lb/hr	kg/hr	lb/hr	kg/hr	lb/hr	kg/hr	lb/hr	kg/hr
15	1.03	189	85	336	152	527	239	864	391	1349	611	2211	1002	3161	1433
20	1.37	218	98	388	175	608	275	997	452	1555	705	2550	1156	3644	1652
30	2.06	275	124	491	222	769	348	1261	571	1968	892	3226	1463	4611	2091
40	2.75	339	153	604	273	947	429	1552	703	2422	1098	3970	1800	5674	2573
50	3.44	403	182	718	325	1124	509	1843	835	2876	1304	4714	2138	6738	3056
60	4.13	466	211	831	376	1301	590	2134	967	3330	1510	5458	2475	7801	3538
70	4.82	530	240	944	428	1479	670	2425	1099	3784	1716	6203	2813	8865	4021
80	5.51	593	268	1058	479	1656	751	2716	1231	4238	1922	6947	3151	9928	4503
90	6.20	657	298	1171	531	1834	831	3007	1363	4692	2128	7691	3488	10991	4985
100	6.89	721	327	1285	582	2011	912	3297	1495	5146	2334	8435	3826	12055	5468
120	8.27	848	384	1511	685	2366	1073	3879	1759	6054	2746	9923	4500	14182	6432
140	9.65	975	442	1738	788	2721	1234	4461	2023	6962	3157	11411	5175	16308	7397
160	11.03	1102	499	1965	891	3076	1395	5043	2287	7870	3569	12899	5850	18435	8361
180	12.41	1230	557	2191	993	3431	1556	5625	2551	8778	3981	14388	6526	20562	9326
200	13.78	1357	615	2418	1096	3786	1717	6207	2815	9685	4393	15876	7201	22689	10291
220	15.16	1484	673	2645	1199	4141	1878	6789	3079	10593	4804	17364	7876	24816	11256
240	16.54	1611	730	2871	1302	4496	2039	7370	3342	11501	5216	18852	8551	26943	12221
260	17.92	1739	788	3098	1405	4851	2200	7952	3606	12409	5628	20340	9226	29069	13185
280	19.30	1866	846	3325	1508	5206	2361	8534	3870	13317	6040	21828	9901	31196	14150
300	20.68	1993	904	3552	1611	5561	2522	9116	4134	14225	6452	23317	10576	33323	15115
320	22.06	2120	961	3778	1713	5916	2683	9698	4398	15133	6864	24805	11251	35540	16079
340	23.44	2247	1019	4005	1816	6271	2844	10280	4662	16041	7276	26293	11926	37577	17044
360	24.82	2375	1077	4232	1919	6625	3005	10861	4926	16949	7687	27781	12601	39703	18008
380	26.20	2502	1134	4458	2022	6980	3166	11443	5190	17857	8099	29269	13276	41830	18973
400	27.57	2629	1192	4685	2125	7335	3327	12025	5454	18765	8511	30758	13951	43957	19938
420	28.95	2756	1250	4912	2228	7690	3488	12607	5718	19673	8923	32246	14626	46084	20903
440	30.33	2884	1308	5139	2331	8045	3649	13189	5982	20581	9335	33734	15301	48211	21868
460	31.71	3011	1365	5365	2433	8400	3810	13771	6246	21489	9747	35222	15976	50338	22832
480	33.09	3138	1423	5592	2536	8755	3971	14353	6510	22396	10158	36710	16651	52464	23797
500	34.47	3265	1480	5819	2639	9110	4132	14934	6773	23304	10570	38198	17326	54591	24762
600	41.36	3901	1769	6952	3153	10885	4937	17844	8093	27844	12629	45639	20701	65225	29585
700	48.26	4538	2058	8086	3667	12659	5742	20753	9413	32384	14689	53080	24076	75860	34409
750	51.71	4856	2202	8653	3924	13547	6144	22207	10072	34654	15718	56801	25764	81177	36821
800	55.15	5174	2346	9219	4181	14434	6547	23662	10732	36923	16747	60521	27451	86494	39233
900	62.05	5810	2635	10353	4696	16209	7352	26571	12052	41463	18807	67962	30827	97128	44056
1000	68.94	6446	2923	11486	5209	17983	8156	29480	13371	46003	20866	75403	34202	107762	48880
1100	75.84	7082	3212	12620	5724	19758	8962	32390	14691	50542	22925	82844	37577	118396	53703
1200	82.73	7718	3500	13754	6238	21533	9767	35299	16011	55082	24984	90285	40952	129030	58527
1300	89.63	8355	3789	14887	6752	23307	10571	38208	17330	59622	27044	97726	44327	139664	63350
1400	96.52	8991	4078	16021	7267	25082	11377	41117	18650	64161	29102	105167	47702	150298	68174
1423	98.11	9137	4144	16281	7384	25490	11562	41786	18953	65204	29576	106876	48478	152742	69282
1500	103.42	9673	4387	17236	7818	26986	12240	44238	20066	69030	31311	113147	51322	161704	73347
1750	120.65	11470	5202	20438	9270	31998	14514	52454	23792	81852	37127	134163	60855	191738	86970
2000	137.89	13374	6066	23832	10810	37311	16923	61164	27743	95444	43292	156441	70960	223577	101412
2250	155.13	15429	6998	27492	12470	43042	19523	70559	32005	110104	49942	180470	81859	257918	116989
2500	172.36	17699	8028	31538	14305	49375	22396	80941	36714	126304	57290	207024	93904	295868	134203
2750	189.60	20297	9206	36167	16405	56624	25684	92823	42103	144845	65700	237414	107689	339299	153903
2903 <sup>2</sup>	200.15	22131	10038	39434	17886	61739	28004	101208	45907	157929	71635	258861	117417	369950	167806

### Notes:

- The following Napier factor is applied to the capacity of pressures greater than 1423 psig (98.11 barg):
 
$$\left[ \frac{.1906 \times P_{psia} - 1000}{.2292 \times P_{psia} - 1061} \right]$$
- Maximum permissible set pressure on steam is 2903 psig (200.15 barg). Value is interpolated.

# Capacities - Steam

## Valve Capacity for ASME B and PV Code Section VIII - Standard Bore, Saturated Steam

Capacities Based at 10 percent overpressure or 3 psig (0.21 barg), whichever is greater, showing 90 percent actual capacity in accordance with latest ASME Code requirements.

Orifice Designation		L		M		N		P		Q		R		T	
		in <sup>2</sup>	cm <sup>2</sup>	in <sup>2</sup>	cm <sup>2</sup>	in <sup>2</sup>	cm <sup>2</sup>	in <sup>2</sup>	cm <sup>2</sup>	in <sup>2</sup>	cm <sup>2</sup>	in <sup>2</sup>	cm <sup>2</sup>	in <sup>2</sup>	cm <sup>2</sup>
Orifice Area		3.317	21.400	4.186	27.006	5.047	32.561	7.417	47.852	12.850	82.903	18.600	120.000	30.210	194.903
Set Pressure		Orifice Capacity													
psig	barg	lb/hr	kg/hr	lb/hr	kg/hr	lb/hr	kg/hr	lb/hr	kg/hr	lb/hr	kg/hr	lb/hr	kg/hr	lb/hr	kg/hr
15	1.03	4904	2224	6189	2807	7462	3384	10966	4974	18999	8617	27501	12474	44668	20261
20	1.37	5654	2564	7135	3236	8603	3902	12643	5734	21905	9935	31707	14382	51498	23359
30	2.06	7154	3245	9028	4095	10885	4937	15997	7256	27715	12571	40117	18196	65158	29555
40	2.75	8804	3993	11110	5039	13395	6075	19686	8929	34106	15470	49368	22392	80184	36370
50	3.44	10453	4741	13192	5983	15906	7214	23375	10602	40498	18369	58620	26589	95210	43186
60	4.13	12103	5489	15274	6928	18416	8353	27064	12276	46889	21268	67871	30785	110236	50002
70	4.82	13753	6238	17356	7872	20926	9491	30753	13949	53281	24167	77123	34982	125262	56817
80	5.51	15403	6986	19438	8816	23437	10630	34442	15622	59672	27066	86374	39178	140288	63633
90	6.20	17053	7735	21520	9761	25947	11769	38132	17296	66064	29966	95625	43374	155314	70449
100	6.89	18703	8483	23603	10706	28457	12907	41821	18969	72455	32865	104877	47571	170340	77264
120	8.27	22002	9979	27767	12594	33478	15185	49199	22316	85238	38663	123380	55964	200393	90896
140	9.65	25302	11476	31931	14483	38499	17462	56577	25662	98021	44461	141882	64356	230445	104528
160	11.03	28602	12973	36095	16372	43519	19739	63955	29009	110804	50259	160385	72749	260497	118159
180	12.41	31901	14470	40259	18261	48540	22017	71334	32356	123586	56057	178888	81142	290549	131790
200	13.78	35201	15966	44423	20149	53560	24294	78712	35703	136369	61855	197391	89535	320601	145422
220	15.16	38501	17463	48587	22038	58581	26571	86090	39049	149152	67654	215893	97927	350653	159053
240	16.54	41800	18960	52751	23927	63602	28849	93468	42396	161935	73452	234396	106320	380705	172684
260	17.92	45100	20457	56916	25816	68622	31126	100847	45743	174718	79250	252899	114713	410757	186316
280	19.30	48400	21953	61080	27705	73643	33403	108225	49090	187501	85049	271402	123105	440809	199947
300	20.68	51699	23450	65244	29594	78664	35681	115603	52436	200283	90846	289905	131498	470862	213579
320	22.06	54999	24947	69408	31482	83684	37958	122981	55783	213066	96645	308407	139891	500914	227210
340	23.44	58299	26443	73572	33371	88705	40235	130360	59130	225849	102443	326910	148283	530966	240842
360	24.82	61598	27940	77736	35260	93725	42512	137738	62476	238632	108241	345413	156676	561018	254473
380	26.20	64898	29437	81900	37149	98746	44790	145116	65823	251415	114039	363916	165069	591070	268104
400	27.57	68198	30934	86064	39037	103767	47067	152494	69170	264198	119838	382419	173462	621122	281736
420	28.95	71497	32430	90228	40926	108787	49344	159873	72517	276981	125636	400921	181854	651174	295367
440	30.33	74797	33927	94393	42815	113808	51622	167251	75863	289763	131434	419424	190247	681226	308998
460	31.71	78097	35424	98557	44704	118829	53899	174629	79210	302546	137232	437927	198640	711279	322630
480	33.09	81396	36920	102721	46593	123849	56176	182007	82556	315329	143030	456430	207033	741331	336262
500	34.47	84696	38417	106885	48482	128870	58454	189385	85903	328112	148829	474933	215425	771383	349893
600	41.36	101194	45900	127706	57926	153973	69840	226277	102637	392026	177820	567447	257389	921643	418050
700	48.26	117693	53384	148526	67370	179076	81227	263168	119371	455940	206810	659961	299353	1071904	486207
750	51.71	125942	57126	158937	72092	191628	86921	281613	127737	487897	221306	706218	320335	1147034	520285
800	55.15	134191	60868	169347	76814	204179	92614	300059	136104	519855	235802	752475	341316	1222165	554364
900	62.05	150689	68351	190167	86258	229282	104000	336950	152837	583769	264793	844989	383280	1372425	622521
1000	68.94	167188	75835	210988	95702	254385	115387	373841	169571	647683	293784	937503	425244	1522686	690678
1100	75.84	183686	83318	231809	105146	279489	126774	410733	186305	711597	322774	1030017	467207	1672947	758836
1200	82.73	200184	90801	252629	114590	304592	138160	447624	203038	775512	351766	1122531	509171	1823207	826992
1300	89.63	216683	98285	273450	124034	329695	149547	484515	219772	839426	380757	1215044	551134	1973468	895150
1400	96.52	233181	105769	294271	133479	354798	160933	521406	236505	903340	409748	1307558	593098	2123728	963306
1423 <sup>1</sup>	98.11	236971	107488	299054	135648	360565	163549	529882	240350	918024	416408	1328814	602739	2158251	978966
1500	103.42	250876	113795	316602	143608	381722	173146	560974	254453	971891	440842	1406785	638106	2284891	1036409
1750	120.65	297472	134931	375405	170280	452621	205305	665165	301713	—	—	—	—	—	—
2000	137.89	346869	157337	437744	198557	527781	239397	775620	351815	—	—	—	—	—	—
2250	155.13	400148	181504	504980	229055	608847	276168	894753	405853	—	—	—	—	—	—
2500	172.36	459025	208210	—	—	—	—	—	—	—	—	—	—	—	—
2750	189.60	526406	238773	—	—	—	—	—	—	—	—	—	—	—	—
2903 <sup>2</sup>	200.15	573959	260343	—	—	—	—	—	—	—	—	—	—	—	—

### Notes:

- The following Napier factor is applied to the capacity of pressures greater than 1423 psig (98.11 barg):
 
$$\left[ \frac{.1906 \times P_{psia} - 1000}{.2292 \times P_{psia} - 1061} \right]$$
- Maximum permissible set pressure on steam is 2903 psig (200.15 barg). Value is interpolated.



# Capacities - Steam

## Valve Capacity for ASME B and PV Code Section VIII - Full Bore, Saturated Steam

Capacities Based at 10 percent overpressure or 3 psig (0.21 barg), whichever is greater, showing 90 percent actual capacity in accordance with latest ASME Code requirements.

Orifice Designation		1.5" (38.1 mm) FB		2" (50.8 mm) FB		3" (76.2 mm) FB		4" (101.6 mm) FB		6" (152.4 mm) FB		8" (203.2 mm) FB		10" (254 mm) FB		12" (304.80 mm) FB	
Orifice Area		in <sup>2</sup>	cm <sup>2</sup>	in <sup>2</sup>	cm <sup>2</sup>	in <sup>2</sup>	cm <sup>2</sup>	in <sup>2</sup>	cm <sup>2</sup>	in <sup>2</sup>	cm <sup>2</sup>	in <sup>2</sup>	cm <sup>2</sup>	in <sup>2</sup>	cm <sup>2</sup>	in <sup>2</sup>	cm <sup>2</sup>
Set Pressure		Orifice Capacity															
psig	barg	lb/hr	kg/hr	lb/hr	kg/hr	lb/hr	kg/hr	lb/hr	kg/hr	lb/hr	kg/hr	lb/hr	kg/hr	lb/hr	kg/hr	lb/hr	kg/hr
15	1.03	2398	1087	4086	1853	9346	4239	15909	7216	36890	16733	65324	29630	103412	46906	166253	75411
20	1.37	2764	1253	4711	2136	10775	4887	18342	8319	42531	19291	75312	34160	119225	54079	191674	86941
30	2.06	3498	1586	5961	2703	13633	6183	23207	10526	53813	24409	95289	43222	150850	68424	242516	110003
40	2.75	4305	1952	7336	3327	16777	7609	28559	12954	66223	30038	117264	53190	185637	84203	298442	135371
50	3.44	5111	2318	8711	3951	19921	9036	33911	15381	78633	35667	139238	63157	220424	99982	354368	160738
60	4.13	5918	2684	10085	4574	23065	10462	39263	17809	91042	41295	161213	73124	255211	115761	410294	186106
70	4.82	6725	3050	11460	5198	26209	11888	44615	20237	103452	46925	183187	83092	289999	131541	466220	211473
80	5.51	7532	3416	12835	5821	29353	13314	49967	22664	115862	52554	205162	93059	324786	147320	522146	236841
90	6.20	8338	3782	14210	6445	32497	14740	55319	25092	128272	58183	227137	103027	359573	163099	578073	262209
100	6.89	9145	4148	15584	7068	35641	16166	60670	27519	140682	63812	249111	112994	394360	178878	633999	287577
120	8.27	10759	4880	18334	8316	41929	19018	71374	32374	165501	75069	293060	132929	463935	210437	745851	338312
140	9.65	12372	5611	21084	9563	48217	21870	82078	37229	190321	86328	337009	152864	533509	241995	857703	389047
160	11.03	13986	6343	23833	10810	54505	24723	92782	42085	215140	97585	380958	172799	603084	273554	969556	439783
180	12.41	15599	7075	26583	12057	60793	27575	103485	46940	239960	108844	424908	192735	672658	305112	1081408	490518
200	13.78	17213	7807	29332	13304	67081	30427	114189	51795	264780	120102	468857	212669	742233	336671	1193260	541253
220	15.16	18826	8539	32082	14552	73369	33279	124893	56650	289599	131359	512806	232604	811807	368229	1305113	591989
240	16.54	20440	9271	34831	15799	79657	36131	135597	61505	314419	142618	556755	252539	881382	399788	1416965	642724
260	17.92	22053	10003	37581	17046	85945	38983	146301	66361	339238	153875	600704	272474	950956	431346	1528817	693459
280	19.30	23667	10735	40330	18293	92233	41836	157004	71215	364058	165133	644653	292409	1020531	462905	1640670	744195
300	20.68	25280	11466	43080	19540	98521	44688	167708	76071	388878	176392	688602	312344	1090105	494463	1752522	794930
320	22.06	26894	12198	45830	20788	104808	47540	178412	80926	413697	187649	732551	332279	1159680	526022	1864374	845665
340	23.44	28508	12931	48579	22035	111096	50392	189116	85781	438517	198907	776500	352214	1229254	557580	1976227	896401
360	24.82	30121	13662	51329	23282	117384	53244	199819	90636	463337	210166	820450	372149	1298829	589138	2088079	947136
380	26.20	31735	14394	54078	24529	123672	56096	210523	95491	488156	221423	864399	392084	1368403	620697	2199931	997871
400	27.57	33348	15126	56828	25776	129960	58948	221227	100346	512976	232682	908348	412019	1437978	652255	2311784	1048607
420	28.95	34962	15858	59577	27023	136248	61801	231931	105202	537795	243939	952297	431954	1507552	683814	2423636	1099342
440	30.33	36575	16590	62327	28271	142536	64653	242634	110056	562615	255197	996246	451889	1577127	715372	2535488	1150078
460	31.71	38189	17322	65076	29517	148824	67505	253338	114912	587435	266456	1040195	471824	1646701	746931	2647341	1200813
480	33.09	39802	18053	67826	30765	155112	70357	264042	119767	612254	277713	1084144	491759	1716276	778489	2759193	1251548
500	34.47	41416	18785	70576	32012	161400	73209	274746	124622	637074	288971	1128093	511694	1785850	810047	2871045	1302284
600	41.36	49483	22445	84323	38248	192840	87470	328265	148898	761172	345261	1347839	611369	2133723	967840	3430307	1555961
700	48.26	57551	26104	98071	44484	224280	101731	381783	173173	885270	401551	1567585	711044	2481595	1125632	3989568	1809637
750	51.71	61585	27934	104945	47602	240000	108862	408543	185311	947319	429696	1677457	760881	2655531	1204528	4269199	1936476
800	55.15	65619	29764	111819	50720	255720	115992	435302	197449	1009368	457841	1787330	810719	—	—	—	—
900	62.05	73686	33423	125567	56956	287159	130253	488821	221725	1133466	514131	2007076	910394	—	—	—	—
1000	68.94	81754	37082	139314	63191	318599	144514	542340	246001	1257564	570421	2226821	1010069	—	—	—	—
1100	75.84	89821	40742	153062	69427	350039	158775	595859	270277	1381662	626711	2446567	1109744	—	—	—	—
1200	82.73	97889	44401	166810	75663	381479	173035	649378	294552	1505760	683001	2666312	1209418	—	—	—	—
1300	89.63	105957	48061	180558	81899	412919	187296	702896	318828	1629858	739291	2886058	1309093	—	—	—	—
1400	96.52	114024	51720	194306	88135	444359	201557	756415	343104	1753956	795581	3105804	1408769	—	—	—	—
14231	981.19	115878	52561	197464	89568	451582	204834	768711	348681	1782468	808513	3156291	1431669	—	—	—	—
1500	103.42	122677	55645	209051	94823	478080	216853	813817	369141	1887058	855955	3341492	1515675	—	—	—	—
1750	120.65	145462	65980	247878	112435	566875	257130	964970	437703	—	—	—	—	—	—	—	—
2000	137.89	169617	76936	289040	131106	661008	299828	1125209	510386	—	—	—	—	—	—	—	—
2250	155.13	195670	88754	333436	151244	762537	345880	1298038	588780	—	—	—	—	—	—	—	—
2500	172.36	224461	101813	382497	173497	874735	396773	1489029	675412	—	—	—	—	—	—	—	—
2750	189.60	257410	116759	438645	198966	1003140	455016	1707608	774558	—	—	—	—	—	—	—	—
2903 <sup>2</sup>	200.15	280664	127307	—	—	—	—	—	—	—	—	—	—	—	—	—	—

### Notes:

- The following Napier factor is applied to the capacity of pressures greater than 1423 psig (98.11 barg):
 
$$\left[ \frac{.1906 \times P_{psig} - 1000}{.2292 \times P_{psig} - 1061} \right]$$
- Maximum permissible set pressure on steam is 2903 psig (200.15 barg). Value is interpolated.

# Valve Installation

## Valve Connections

The Consolidated 39MPV Series flanged valves are equipped with ANSI B16.5 flanges. For other standards, contact the factory.

The facing on raised flanges is a spiral finish, 125 to 250 micro inch roughness ( $R_a$ ).

All flange drilling straddles the centerlines of the valve.

## Handling and Storage

Safety relief valves should be handled carefully. The internal parts of a Pilot-Operated safety relief valve are precision machined and fitted together to maintain perfect alignment. Rough handling may damage the external tubing, pilot, and main valve seats or may cause misalignment sufficient to incur leakage or erratic operation. Safety relief valves are shipped with a protective covering over the inlet and the outlet. This is to prevent damage to the flanged surfaces and to prevent entry of foreign material into the valve. If the valves are to be stored before installation, the protective covering should be left intact until installation. A clean, dry storage area is recommended. Valves should always be protected with a suitable covering to prevent entry of foreign material.

## Inlet Piping

Pilot-operated safety relief valves must be installed in a vertical upright position. The inlet piping to the valve should be short and direct from the vessel or equipment being protected. The connection to the vessel should be provided with a radius to permit smooth flow to the valve. Sharp corners should be avoided. Should this not be practical, then the

inlet should be swaged out at least one additional pipe diameter.

In any case, the pressure drop from the vessel to the valve should not exceed 3 percent of set pressure when the valve is flowing full capacity. In no event should the inlet piping be smaller in diameter than the inlet connection of the valve.

## Outlet Piping

Alignment of the internal parts of a Pilot-Operated safety relief valve is important to ensure proper operation. Although the valve body will withstand a considerable mechanical load, unsupported discharge piping should not impose loads any higher than those stated in the Technical Information section of this catalog, consisting of more than a companion flange, long radius elbow and a short vertical pipe. Care should be taken to ensure thermal expansion of piping and supports does not produce strains on the valve. Spring supports are recommended where necessary to avoid this condition. The discharge piping should be designed to allow for vessel expansion as well as expansion of the discharge pipe itself. This is particularly important on long discharge lines.

Consideration should be given to discharge pipe movement resulting from wind loads. Any oscillation of the discharge piping introduces stress distortion in the valve body, and the resultant movement of the internal parts may cause leakage.

# Valve Configuration Code

## 3900 Series Main Valve

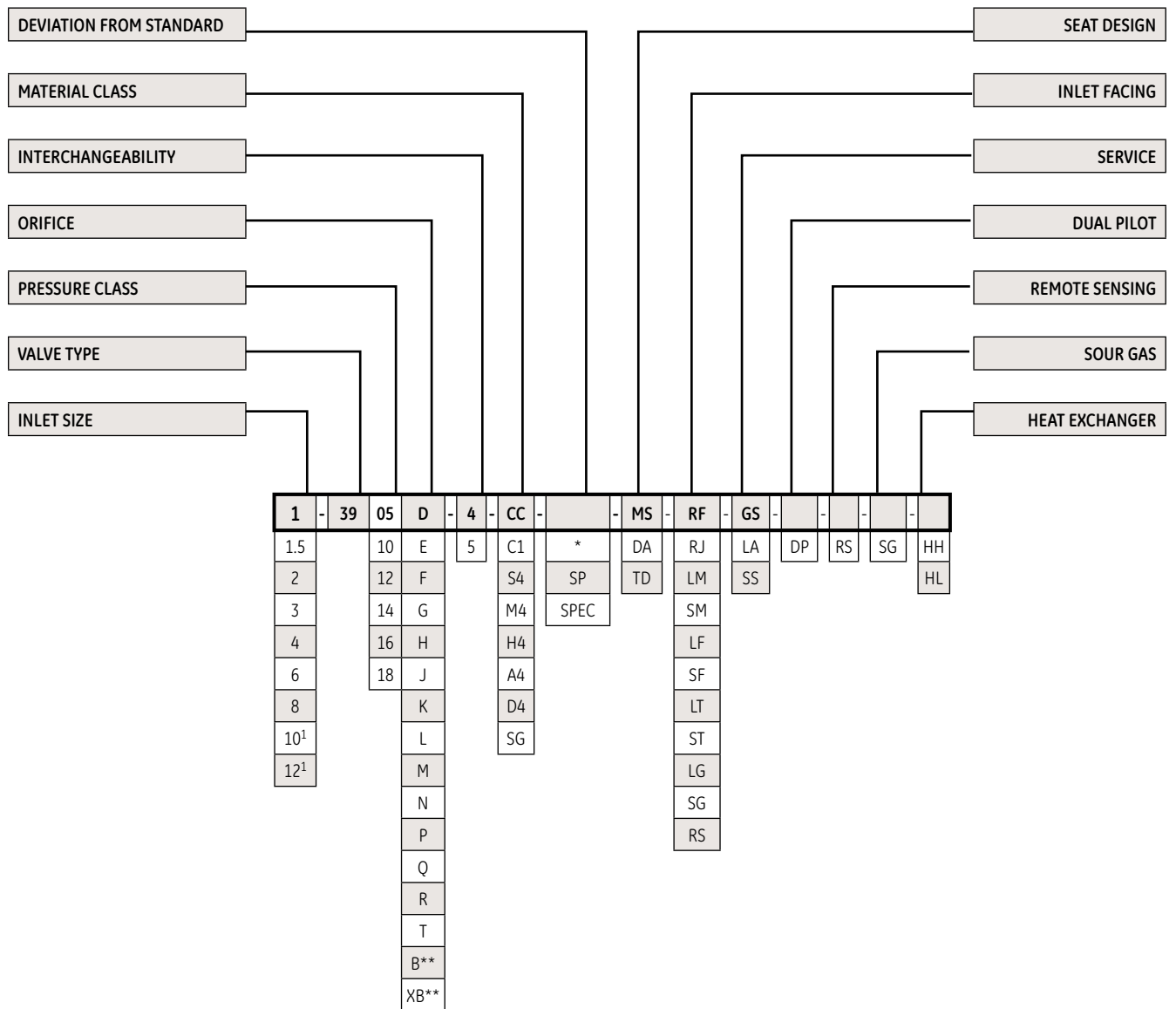

**Notes:**  
 1. Denotes Full-Bore (FB) offering only

# Valve Configuration Code

## 3900 Series Main Valve

Pressure Class	
Designation	Class
05	150
10	300
12	600
14	900
16	1500
18	2500

Seat Design	
Designation	Type
MS	Metal Seat
DA	O-ring
TD	Thermodisc

Service	
Designation	Type
GS	Gas
LA	Liquid
SS	Steam

Standard Bore Connection		
Orifice	Area (ASME)	
	in <sup>2</sup>	cm <sup>2</sup>
D	0.128	0.825
E	0.228	1.470
F	0.357	2.302
G	0.585	3.774
H	0.913	5.888
J	1.496	9.652
K	2.138	13.794
L	3.317	21.400
M	4.186	27.006
N	5.047	32.561
P	7.417	47.852
Q	12.850	82.903
R	18.600	120.000
T	30.210	194.903

Heat Exchanger	
Designation	Type
HH	Media is 506°F (263°C) or above
HL	Media is -41°F (-40.6°C) or below

Interchangeability	
Designation	Valve Type
4	All soft seated design except 3918K
5	All metal seat design and 3918K soft seat design

Material Class Variations	
Designation	Variation
CC	Standard Material
C1	Ambient Temp. to -50°F (-45.6°C) (LCC Construction/316 Stainless Steel Coverplate)
S4	Stainless Steel (Complete Valve)
M4	Monel (Complete Valve)
H4	Hastelloy C (Complete Valve)
A4	Alloy 20 (Complete Valve)
D4	Duplex (All Except Stud/Nut and Bellows Assembly)
SG	Sour Gas

Inlet Flange Facing	
Designation	Facing
RF	Raised Face Serrated
RJ	Ring Joint
LM	Large Male
SM	Small Male
LF	Large Female
SF	Small Female
LT	Large Tongue
ST	Small Tongue
LG	Large Groove
SG	Small Groove
RS	Raised Face/Smooth

Full Bore Connection	
Designation	Variation
B	Single Outlet [1.5" (38.1 mm) - 4" (101.6 mm)] Double Outlet [6" (152.4 mm) - 12" (304.8 mm)]
XB	Single Outlet [6" (152.4 mm) - 12" (304.8 mm)]

# Valve Configuration Code

## 3900 Series Pilot Valve

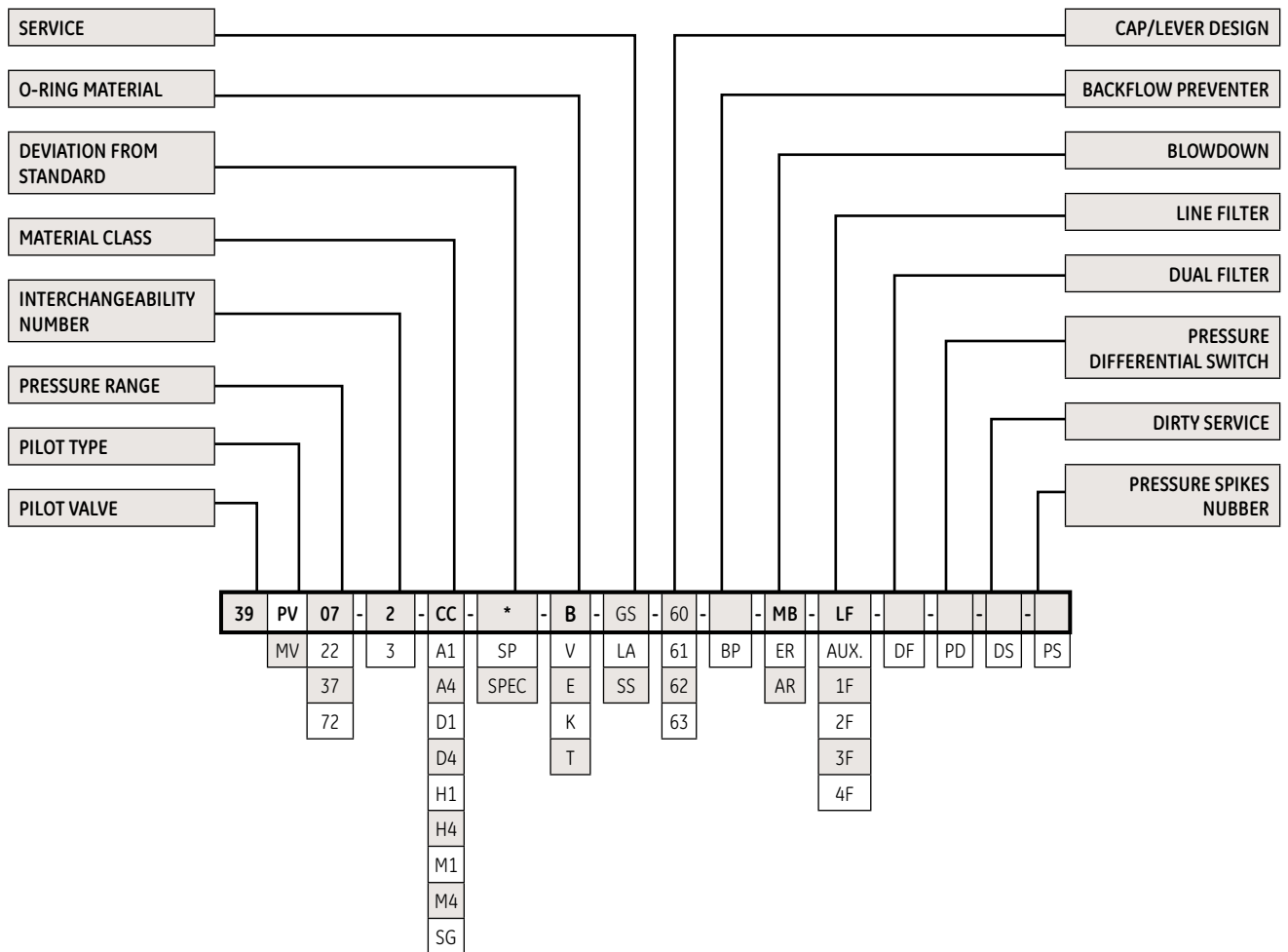

# Valve Configuration Code

## 3900 Series Pilot Valve

Pilot Type	
Designation	Description
PV	Pop Pilot
MV	Modulating Pilot

Pressure Range	
Designation	Description
07	15 to 750 psig (1.03 - 51.71 barg)
22	751 to 3750 psig (51.78 - 258.55 barg) [MV only]
37	751 to 3750 psig (51.78 - 258.55 barg) [PV only]
72	3751 to 6250 psig (258.62 - 430.92 barg) [MV only]

Interchangability Number	
Designation	Description
2	Screwed Cap
3	Lifting Lever and/or Gag

Blowdown	
Designation	Description
MB	Manual Blowdown
ER	Electronic Blowdown
AR	Air Remote

O-ring Material	
Designation	Description
B	Buna (Nitrile)
V	Viton (Fluorocarbon)
E	Ethylene Propylene
K	Kalrez
T	Teflon

Cap / Lever Design	
Designation	Description
60	Screwed Cap (No Gag or Lifting Lever)
61	Gag Only
62	Lifting Lever
63	Gag and Lifting Lever

Sensing Line Filter	
Designation	Description
LF	Line Filter (Standard)
AUX.	High Capacity Filter
1F	Carbon Steel
2F	Stainless Steel
3F	Carbon Steel With Flush Valve
4F	Stainless Steel With Flush Valve

Service	
Designation	Description
GS	Gas
LA	Liquid
SS	Steam

Material Class Variations	
Designation	Description
CC	Standard Material
A1	Alloy 20 [Wetted Parts] (Consult Factory)
A4	Alloy 20 [Complete Valve] (Consult Factory)
D1	Duplex [Wetted Parts] (Consult Factory)
D4	Duplex [Complete Valve] (Consult Factory)
H1	Hastelloy C [Wetted Parts]
H4	Hastelloy C [Complete Valve]
M1	Monel [Wetted Parts]
M4	Monel [Complete Valve]
SG	Sour Gas

# Ordering a 3900 Series MPV Safety Relief Valve

Specification Sheet			
		Page ____ of ____	
Requisition No.	_____		
Job No.	_____		
Date	_____		
Revised By	_____		
General			
1.	Item Number:		
2.	Tag Number:		
3.	Service, Line or Equipment No:		
4.	Number Required:		
Basis of Selection			
5.	Code: ASME VIII Stamp Required: <input type="checkbox"/> YES <input type="checkbox"/> NO <input type="checkbox"/> OTHER Specify:		
6.	Comply with API 526: <input type="checkbox"/> YES <input type="checkbox"/> NO		
7.	<input type="checkbox"/> Fire <input type="checkbox"/> OTHER Specify:		
8.	Rupture Disk: <input type="checkbox"/> YES <input type="checkbox"/> NO		
Valve Design			
9.	Design Type: Pilot		
10.	No. of Pilots:		
11.	Pilot Action : <input type="checkbox"/> Pop <input type="checkbox"/> Modulating		
12.	Pilot Sense: <input type="checkbox"/> Internal <input type="checkbox"/> Remote <sup>1</sup>		
13.	Seat Type: Resilient		
14.	Seat Tightness: <input type="checkbox"/> API 527 <input type="checkbox"/> OTHER Specify:		
15.	Pilot Vent: <input type="checkbox"/> Atmosphere <input type="checkbox"/> Outlet <input type="checkbox"/> OTHER Specify:		
16.	Main Base: <input type="checkbox"/> Metal Seat <input type="checkbox"/> Resilient Seat		
Connections			
17.	Inlet Size:	Rating:	Facing:
18.	Outlet Size:	Rating:	Facing:
19.	<input type="checkbox"/> OTHER Specify:		
Materials, Main Valve			
20.	Body		
21.	Nozzle:		
22.	Seat O-ring:		
23.	Disc:		
24.	Disc Seal:		
25.	Other O-rings:		
26.	Guide:		
27.	Cover Plate:		
Materials, Pilot			
28.	Body/Bonnet:		
29.	Internals:		
30.	Seat:	Seal:	
31.	Tubing/Fittings:		
32.	Spring:		
33.	Comply with NACE MR0175: <input type="checkbox"/> YES <input type="checkbox"/> NO		
34.	<input type="checkbox"/> OTHER Specify:		
Accessories			
35.	External Filter: <input type="checkbox"/> YES <input type="checkbox"/> NO		
36.	Lifting Lever: N/A		
37.	Field Test Connection: <input type="checkbox"/> YES <input type="checkbox"/> NO		
38.	Backflow Preventer: <input type="checkbox"/> YES <input type="checkbox"/> NO		
39.	Manual Blowdown Valve: <input type="checkbox"/> YES <input type="checkbox"/> NO		
40.	Heat Exchange (For High and Low Temperature Applications): <input type="checkbox"/> YES <input type="checkbox"/> NO		
41.	Dirty Service: <input type="checkbox"/> YES <input type="checkbox"/> NO		
42.	<input type="checkbox"/> OTHER Specify:		
Service Conditions			
43.	Fluid and State:		
44.	Required Capacity per Valve and Units:		
45.	Molecular Weight or Specific Gravity:		
46.	Viscosity at Flowing Temperature and Units:		
47.	Operating Pressure and Units:		
48.	Blowdown: <input type="checkbox"/> Standard <input type="checkbox"/> Other		
49.	Latent Heat of Vaporization and Units:		
50.	Operating Temperature and Units:		
51.	Relieving Temperature and Units:		
52.	Built-up Back Pressure and Units:		
53.	Superimposed Back Pressure and Units:		
54.	Cold differential Test Pressure and Units:		
55.	Allowable Overpressure in Percent or Units:		
56.	Compressibility Factor, Z:		
57.	Ratio of Specific Heats:		
Sizing and Selection			
58.	Calculated Orifice Area: ----- in <sup>2</sup> ----- cm <sup>2</sup>		
59.	Selected Orifice Area: ----- in <sup>2</sup> ----- cm <sup>2</sup>		
60.	Orifice Designation (letter):		
61.	Manufacturer:		
62.	Model Number:		
63.	Vendor Calculations Required: <input type="checkbox"/> YES <input type="checkbox"/> NO		
Remote Sensing			
64.	Sizing Required:		
65.	Set Pressure: ----- psig ----- barg		
66.	Orifice Selection:		
67.	Fluid Density of Media in condensed state: _____ lbm/ft <sup>3</sup> _____ kgm/mtr <sup>3</sup>		
68.	Length of Sensing Line <sup>1</sup> : _____ ft _____ mtr		
69.	Equivalent Length of Sensing Line for Valves, Elbows, Tees etc.:		
70.	Total change in Height: _____ ft _____ mtr		
Notes:			
1. To assure proper valve operation when pilot is remotely sensed use .375" (9.53 mm) diameter tubing for lengths up to ten feet. Contact factory for proper size of tubing when sensing line exceeds ten feet (3.05 mtr).			



\* Consolidated, is a registered trademark of the General Electric Company.  
Other company names and product names used in this document are the registered trademarks or  
trademarks of their respective owners.  
© 2014 General Electric Company. All rights reserved.