

word root loqu means speak

fatigue

forest

league

hop

plants

shorter

eloquently

word root enni means year

or

lighter

happiest

Spelling

blue

Week of _____

symmetrical

loquaciousness

regurgitate

work

gut

tune

centennial

loquaciously

perennial

emperor

guys

roller

My Name: _____

Your Words

Pick 3 to do:

- page 1
- page 2
- pages 3-4
- page 5

Math Break

Pick 1 to do:

- page 8
- page 9
- page 10
- page 11
- page 12
- page 13

Spelling Workout

Pick 7 to do:

- page 14
- page 15
- page 16
- page 17
- page 18
- page 19
- page 20
- page 21
- page 22

Spelling Break

Pick 1 to do:

- page 23
- page 24
- page 25
- page 26

GU Words

Pick 2 to do:

- page 28
- page 29
- page 30

Vocabulary

Do all of these:

- page 6
- page 7

Challenge Words

Do this:

- page 27

Name: _____



Read the Word.

Copy the Word.

Copy the Word.

1. hop
2. tune
3. file
4. slogan
5. eloquently
6. loquaciously
7. loquaciousness
8. perennial
9. centennial
10. plants
11. work
12. blue
13. lighter
14. roller
15. forest
16. happiest
17. emperor
18. or
19. guys
20. gut
21. regurgitate
22. fatigue
23. league
24. symmetrical
25. shorter

_____	_____
_____	_____
_____	_____
_____	_____
_____	_____
_____	_____
_____	_____
_____	_____
_____	_____
_____	_____
_____	_____
_____	_____
_____	_____
_____	_____
_____	_____
_____	_____
_____	_____
_____	_____
_____	_____
_____	_____
_____	_____
_____	_____
_____	_____
_____	_____
_____	_____
_____	_____

Name: _____

Finding Words Multiple Times

Look for words to the RIGHT, to the LEFT, UP, or DOWN.

E S Y M M E T R I C A L R O R
 R E G U R G I T A T E H O P O
 S R E T H G I L E M P E R O R
 Y T S E I P P A H E U G A E L
 M S S E N S U O I C A U Q O L
 M H T A T H R A A P H F R O R
 E A S R S A O U A T O A O R E
 T P E E E P R E O R P T R L U
 R P I T I P E S Y U G I E G G
 I I P H P I P G U Y S G P U A
 C E P G P E M S Y U G U M Y E
 A S A I A S E I H O P E E S L
 L T H L H T L A I N N E R E P

Answers for blanks: 3 1 1 1 3 2 5 2 4 1

I found PERENNIAL _____ time(s).

I found LEAGUE _____ time(s).

I found OR _____ time(s).

I found LOQUACIOUSNESS _____ time(s).

I found HAPPIEST _____ time(s).

I found EMPEROR _____ time(s).

I found SYMMETRICAL _____ time(s).

I found FATIGUE _____ time(s).

I found HOP _____ time(s).

I found REGURGITATE _____ time(s).

Name: _____

Picture Dictionary

Draw a picture of 11 of your words. Write the word.



EXAMPLE. laughed

1. _____

2. _____

3. _____

4. _____

5. _____

Name: _____

6. _____

7. _____

8. _____

9. _____

10. _____

11. _____

Name: _____

C H S L L L L N L T S I L L
 L C L S A I G V T V L L S B S
 L N V A C A L A U G H I A E E
 I U P A D L F L E L Z O S L E
 E L S I L I L E A V E N H A L
 S A D O L I T T L E S S O Z Q
 U E M W A S A E E L H L G Y B
 I L A P S H H L A B E L H A S
 T I S W O L N V G S I O L I L
 S S E I D A L L L L E P J L A

"L" Words

L _____ L _____
 L _____ L _____
 L _____ L _____
 L _____ L _____
 L _____ L _____

I found _____ "L" words.

3 • 7 • - • 1 • + • 4 • 3 • + • 9 • 4 • + • 5 • = • 1 • 1 • 2 • 2
 - • 2 • 5

Use the pieces above to help you fill in the runaway math puzzle.

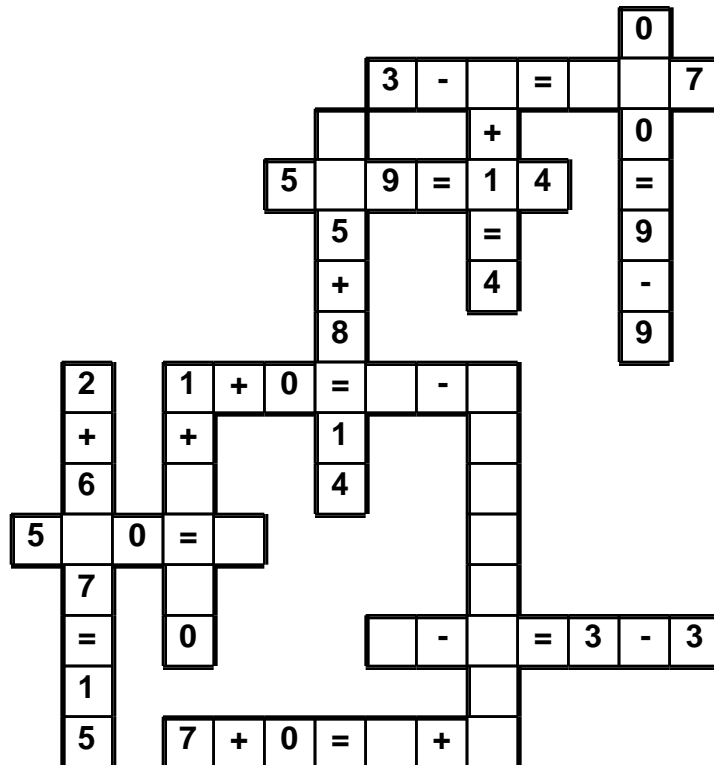

word root **per** can mean **through** **percolate, permeate**

Name: _____

Word Roots to Know:

loqu

means speak

eloquently

loquaciously

loquaciousness

enni

means year

perennial

centennial

Vocabulary is confusing. Get to the root of the problem with word roots! Here are the answers:

centennial • year • loquaciousness • eloquently • loquaciously • enni
perennial

Word with	e e e t u q n e l o q u e n t l y e
the root: loqu	u o l y e l o q u e n t l y l p e l

Word with	u l o q u a c i o u s n e s s r e d
the root: loqu	o q q l o q u a c i o u s n e s s e

Word with	t a c e n t e n n i a l l e t l n i
the root: enni	l y l n b r c e n t e n n i a l g t

Word with	l a s l o q u a c i o u s l y i l s
the root: loqu	s a o y i l o q u a c i o u s l y l

The root: enni	e r r a y a a e y e a r m w y e r a
means	e r e e y e a r y b p n y a e r r r

Word with	i h p n r a p p e r e n n i a l p n
the root: enni	d n t i q g y n l p e r e n n i a l

This root	g e e e u n w q n e i c n e n n i n
means year	a g e v e u n i n e i n j z e n n i

Name: _____

TOXIC	CRUEL	BASK	COMPONENT	ADVERB
DISLIKE			CRATE	EXAMINE
INDUSTRIOUS		RESOLVE		BURY
METAL		INJECT		SENT
MANUFACTURER		PRESCHOOL		VARIABLE
ROAM				DEROGATORY

Circle the words that you know. I circled _____ words.

Use two of the words you know in a sentence.

Write five words that you don't know or want to know better.

Circle words to the RIGHT or DOWN. Every letter is used exactly ONCE.

S V R D H E P R E S C H O O L
H A E I D E R O G A T O R Y
Y R S S C U S E D I M C S R
T I O L R B A K E N E O L T O
O A L I U A N D J T W E A A
X B V K E B U R Y E A S T Y M
I L E E L S E N T C L B A S K
C E E X A M I N E T C R A T E

Name: _____

Fill in the numbers.

	33	34	35	36
	43		45	
			55	56

	27			30
				40
		48		50

65	

11		13	14	
	22			
	32	33		
	42			

		44	45
		54	
62			

54	55
64	
	75

			18	
	26			29
			58	

	25	26		
	35			
44		46		

37

	58		
	68		70
		79	

53		

72	73			
				86
				96

Name: _____

Help Robot find Rover. Make a path of increasing sums. You can only move to a box with a larger sum. Draw a line to show your path.

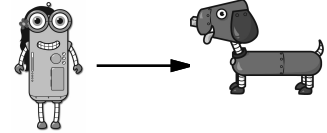

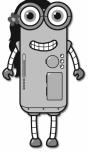
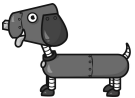
	$\begin{array}{r} 57 \\ +66 \\ \hline \end{array}$	$\begin{array}{r} 69 \\ +41 \\ \hline \end{array}$	$\begin{array}{r} 22 \\ +31 \\ \hline \end{array}$	$\begin{array}{r} 53 \\ +83 \\ \hline \end{array}$	$\begin{array}{r} 97 \\ +60 \\ \hline \end{array}$	$\begin{array}{r} 67 \\ +94 \\ \hline \end{array}$	$\begin{array}{r} 40 \\ +29 \\ \hline \end{array}$	$\begin{array}{r} 87 \\ +25 \\ \hline \end{array}$
$\begin{array}{r} 22 \\ +12 \\ \hline \end{array}$	$\begin{array}{r} 25 \\ +17 \\ \hline \end{array}$	$\begin{array}{r} 38 \\ +18 \\ \hline \end{array}$	$\begin{array}{r} 17 \\ +45 \\ \hline \end{array}$	$\begin{array}{r} 38 \\ +26 \\ \hline \end{array}$	$\begin{array}{r} 41 \\ +29 \\ \hline \end{array}$	$\begin{array}{r} 21 \\ +54 \\ \hline \end{array}$	$\begin{array}{r} 40 \\ +18 \\ \hline \end{array}$	$\begin{array}{r} 64 \\ +53 \\ \hline \end{array}$
$\begin{array}{r} 31 \\ +16 \\ \hline \end{array}$	$\begin{array}{r} 28 \\ +74 \\ \hline \end{array}$	$\begin{array}{r} 82 \\ +13 \\ \hline \end{array}$	$\begin{array}{r} 67 \\ +20 \\ \hline \end{array}$	$\begin{array}{r} 19 \\ +63 \\ \hline \end{array}$	$\begin{array}{r} 30 \\ +50 \\ \hline \end{array}$	$\begin{array}{r} 46 \\ +30 \\ \hline \end{array}$	$\begin{array}{r} 48 \\ +85 \\ \hline \end{array}$	$\begin{array}{r} 78 \\ +40 \\ \hline \end{array}$
$\begin{array}{r} 36 \\ +67 \\ \hline \end{array}$	$\begin{array}{r} 69 \\ +40 \\ \hline \end{array}$	$\begin{array}{r} 60 \\ +12 \\ \hline \end{array}$	$\begin{array}{r} 29 \\ +70 \\ \hline \end{array}$	$\begin{array}{r} 81 \\ +17 \\ \hline \end{array}$	$\begin{array}{r} 85 \\ +39 \\ \hline \end{array}$	$\begin{array}{r} 65 \\ +82 \\ \hline \end{array}$	$\begin{array}{r} 82 \\ +64 \\ \hline \end{array}$	$\begin{array}{r} 88 \\ +51 \\ \hline \end{array}$
$\begin{array}{r} 17 \\ +99 \\ \hline \end{array}$	$\begin{array}{r} 34 \\ +81 \\ \hline \end{array}$	$\begin{array}{r} 18 \\ +99 \\ \hline \end{array}$	$\begin{array}{r} 96 \\ +22 \\ \hline \end{array}$	$\begin{array}{r} 54 \\ +71 \\ \hline \end{array}$	$\begin{array}{r} 74 \\ +52 \\ \hline \end{array}$	$\begin{array}{r} 68 \\ +64 \\ \hline \end{array}$	$\begin{array}{r} 73 \\ +62 \\ \hline \end{array}$	$\begin{array}{r} 61 \\ +79 \\ \hline \end{array}$
$\begin{array}{r} 56 \\ +30 \\ \hline \end{array}$	$\begin{array}{r} 59 \\ +43 \\ \hline \end{array}$	$\begin{array}{r} 24 \\ +97 \\ \hline \end{array}$	$\begin{array}{r} 34 \\ +96 \\ \hline \end{array}$	$\begin{array}{r} 33 \\ +19 \\ \hline \end{array}$	$\begin{array}{r} 41 \\ +95 \\ \hline \end{array}$	$\begin{array}{r} 64 \\ +49 \\ \hline \end{array}$	$\begin{array}{r} 68 \\ +71 \\ \hline \end{array}$	$\begin{array}{r} 77 \\ +65 \\ \hline \end{array}$
$\begin{array}{r} 41 \\ +92 \\ \hline \end{array}$	$\begin{array}{r} 71 \\ +15 \\ \hline \end{array}$	$\begin{array}{r} 43 \\ +22 \\ \hline \end{array}$	$\begin{array}{r} 20 \\ +45 \\ \hline \end{array}$	$\begin{array}{r} 99 \\ +36 \\ \hline \end{array}$	$\begin{array}{r} 28 \\ +34 \\ \hline \end{array}$	$\begin{array}{r} 74 \\ +61 \\ \hline \end{array}$	$\begin{array}{r} 42 \\ +73 \\ \hline \end{array}$	

Name: _____

Make change. You can use \$20, \$10, \$5, \$1, 25¢, 10¢, 5¢, or 1¢.

Use the fewest bills and coins to make \$32.37.

Use the fewest bills and coins to make \$42.54.

Use the fewest bills and coins to make \$43.22.

Use the fewest bills and coins to make \$37.32.

Fill in the missing letters. Write ie or ia.

impat_____nt

unt_____

magic_____n

spec_____l

tr_____ngle

tr_____d

rel_____f

carr_____d

Name: _____

Find the missing numbers. These both have the same rule. What is the rule?

If

$1, 9 = 10$

$2, 14 = 16$

$3, 18 = 21$

$4, 21 = 25$

Then

$5, 24 = ?$

If

$4, 9 = 13$

$5, 14 = 19$

$6, 16 = 22$

$7, 21 = 28$

Then

$8, 24 = ?$

What is the rule for each pattern?

34, 34, 45, 39, 56, 44, 67, 49, 78, 54, _____, _____, 100, 64

_____, _____, 44, 45, 47, 49, 50, 53, 53, 57, 56, 61, 59, 65

7, 7, 20, 16, 33, 25, 46, _____, 59, 43, 72, 52

Name: _____

Mrs. Jackson wrote the numbers 4 and 12 on the board. She always had a weird way to teach math. "Now, class," said Mrs. Jackson. "My printer is broken. Please write your own math problem using these numbers."

$$\begin{array}{r} 48 \\ + \quad 9 \\ \hline \end{array}$$

A, D, G, J, M, P, S,

_____, Y

double 20

$$63 + 63 + 63 + 63 + 63$$

Change this into a
multiplication problem.

____ x ____

Write this number:
9 tens, 2 hundreds, 3
thousands, 8 ones

It is 7:44 when Amanda
leaves her house. She
arrives at school at 8:07.
How much time has
passed?

Name: _____

Mary is playing a game against Rosa. In the game you collect gold coins. You can also get hearts. Every heart is exchanged for 2 gold coins at the end of the game. Mary got 200 gold coins and 28 hearts. Rosa got 36 gold coins and 72 hearts. Who won?

$5 - 3 + 6 + 5$

Write an even number.

In six hours it will be midnight. What time is it now?

How many hours are there from 9 a.m. to 10 p.m.?

5, 7, 9, _____, 13, 15,
17, 19, 21

2 more than 862

Look up the word in the dictionary and write the definition on the line.
procrastinate

$11 + \square = 13$

$6 + \square = 10$

Name: _____

loquaciously o l s a l o q u a c i o u s l y y o n

tune l b a j q t n e n w t u n e i f p o u

blue f b g k b u e b l u e e w n u l i e u

lighter i l i g h t e r t w l i g h e t r e i

hop h o p p u x h o p h o o p j s n d o o

league l e a g u e g l e a g e l a o q r d c

fatigue g u k x i f a t i g u e f a t i u g e

loquaciousness u q s i u l o q u a c i o u s n e s s

eloquently l q e l q t e n e l o q u e n t l y q

or r o n l y o e o o r d r o r h c j m p

guys r y h u s u e j q s g u y s u g y d y

happiest e m a i h a p p i e s t h a p p e s t

centennial c e n t e n n i a l c e n t i n i a l

roller l r o l l e r u l n l r b r o l e r o

file l q i f i l e l e e f u l e e e l l i

regurgitate q a l y f o g r e g u r g i t a t e e

slogan o s l o g e n d a s l o g a n n m g n

gut t i l g u h d a v j g g u t k f n g t

plants n n p l u n t s o r v p p p l a n t s

perennial n x a m i g q p e r e n n i a l l l k

forest m r o t w u f o r e s t e f a r a s t

shorter r s h o r t e r z m s h o r t h e r r

work k x w o l j r c s w o t k a r w o r k

emperor e m p e r o r y r m r e m p o r e r r

symmetrical w b c t s y m m e t r i c a l r r t e

Name: _____

OR • BLUE • FOREST • SLOGAN • HOP • PLANTS • LIGHTER • GUT
TUNE

Write each word into the puzzle.

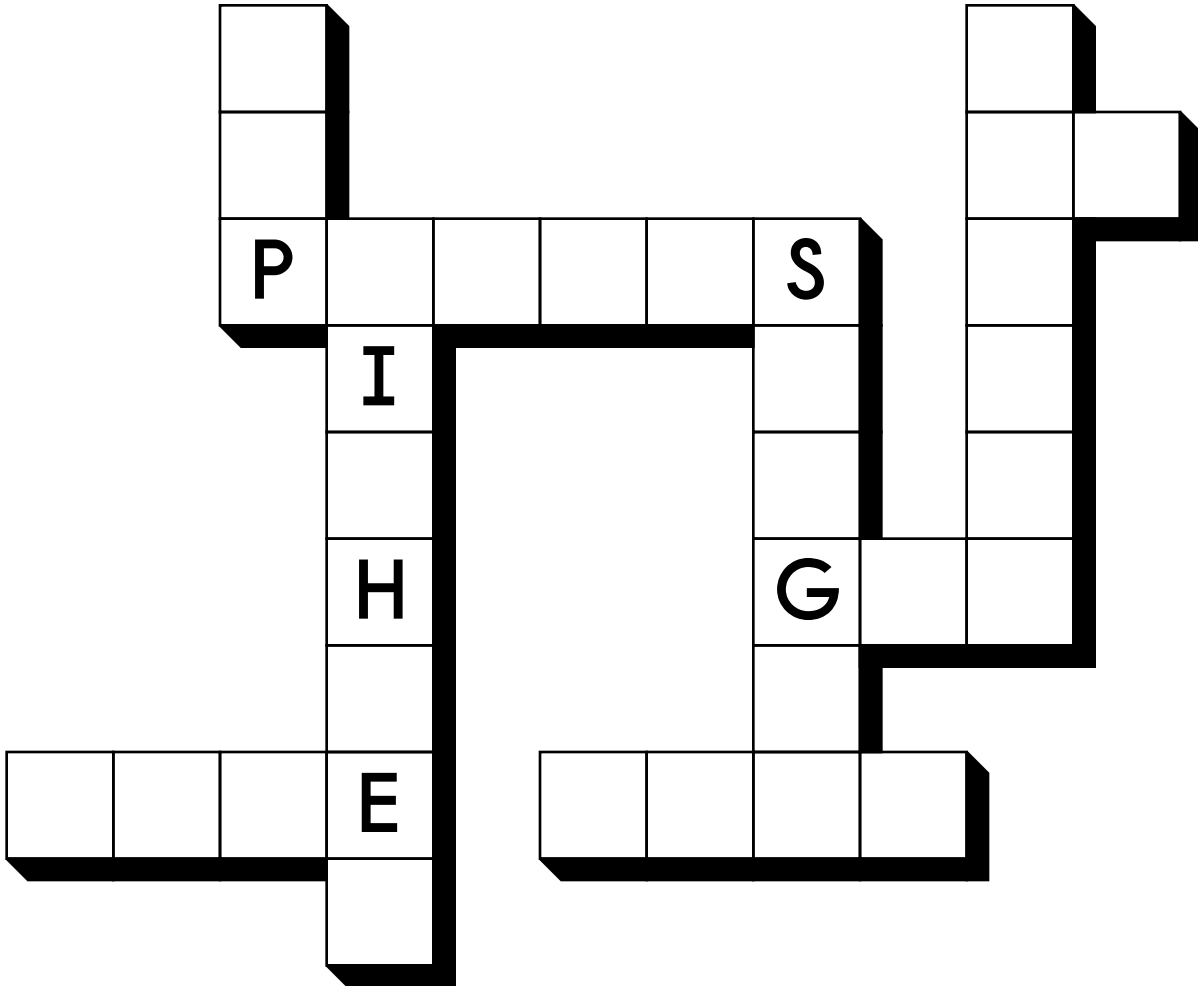

$\begin{array}{r} 15 \\ + 17 \\ \hline \end{array}$	$\begin{array}{r} 98 \\ + 20 \\ \hline \end{array}$	$\begin{array}{r} 79 \\ - 36 \\ \hline \end{array}$	$\begin{array}{r} 38 \\ - 33 \\ \hline \end{array}$	$\begin{array}{r} 68 \\ - 11 \\ \hline \end{array}$	$\begin{array}{r} 39 \\ - 29 \\ \hline \end{array}$
---	---	---	---	---	---

$13 + \square = 15$	$23 + \square = 37$	$18 + \square = 30$	$28 + \square = 33$
---------------------	---------------------	---------------------	---------------------

Name: _____

Use each word ONCE. Cross off each word after it is used.

eloquently • slogan • regurgitate • blue • plants • league
emperor • gut • fatigue • shorter • symmetrical • or • work • guys
loquaciously • centennial • perennial • forest • loquaciousness
lighter • roller • tune

These words have "oquac" in them.

o q u a c _____

These words have the short e
sound like in bed.

_____ r _____

These words have "nial" in
them.

_____ n i a l _____

These words have "gu" in them.

g u _____
g u _____

These words have "ter" in them.

_____ t e r _____

These words have the long o sound like in
boat.

r _____ l _____ r _____

Fit the rest of the words into these shapes.

		n	
--	--	---	--

	o	r				
--	---	---	--	--	--	--

--	--

--	--	--	--	--

--	--	--	--	--	--	--

--	--	--	--	--

Name: _____

describing words:	curly	cute	tired
	popular	shiny	steaming

who or what?	otter	doctor	patient
	parents	drummers	bear

did what?	rested	flew	played a song
	caught my eye	waited	ate food

where?	on the moon	in his office	on the table
	in the back yard		underground

when?	before 9th grade		
	during recess	yesterday	overnight

How many sentences can you write? Use some of the ideas from above.

Think about writing a letter.

Title: Writing a Letter

To whom did you write a letter: _____

What did you write about in your letter: _____

When did you send your letter: _____

Where did your letter go: _____

Why did you write a letter: _____

Name: _____

hop • tune • league • centennial

Each row, column, and box must have all the words from the word list. Write in the missing words.

	centennial	league	hop
		centennial	
	league		

Sudoku Sums of 6

Each row, column, and box must have the numbers 1 through 4.
Hint: Look for sudoku sums. The sum of the two boxes inside of the dashed lines is 6.

Here is an example of a sudoku sum of 6:

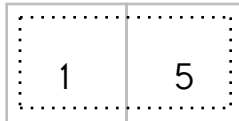

		2	
	4	3	
	1		

- twun
- twuhn
- twinn
- twin

$$5 \overline{)20}$$

$$6 \overline{)48}$$

Circle the nouns.

The playground was flooded, so we had to play on the sidewalk.

Name: _____

Circle the words.

perennialorfilesymmetricalguttuneguysleagueroller
perennialleagueguysorplantsgutfilesymmetricaltune
orguysfilerollerguystuneorleaguegutsymmetricalfile

Write the hidden word. Start at one letter and then move either left or right. Continue in same direction.

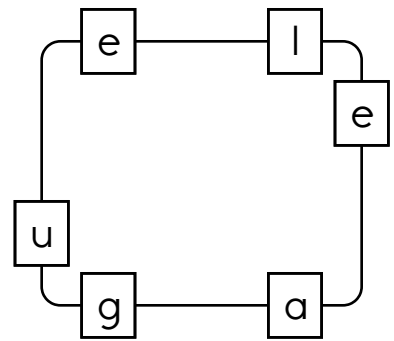
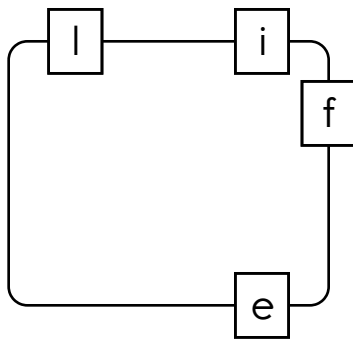
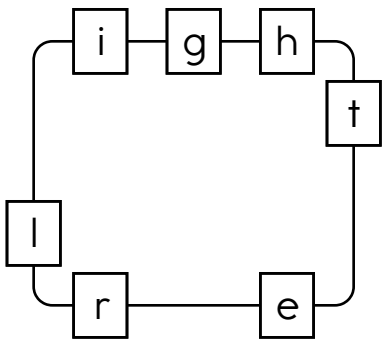

Try to spell some words.

ne • ~~er~~ • tu • er • et • ro • ~~al~~ • al • ~~si~~ • sy • hop
~~en~~ • mm • ll • or • ric

perennial _____

7 x 5 = _____

4 x 4 = _____

$$\begin{array}{r} 70 \\ + 12 \\ \hline \end{array}$$

12 + = 34

20 + = 31

Add one hundred to 631.

Name: _____

Write the hidden word. Start at one letter and then move either left or right. Continue in same direction.

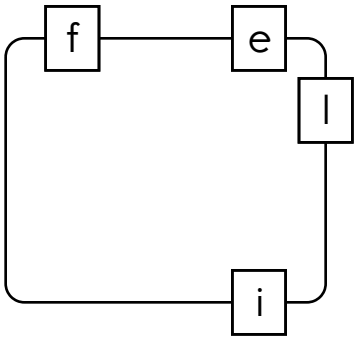

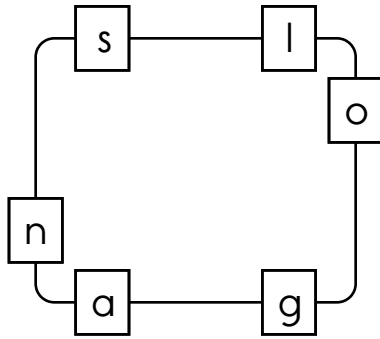

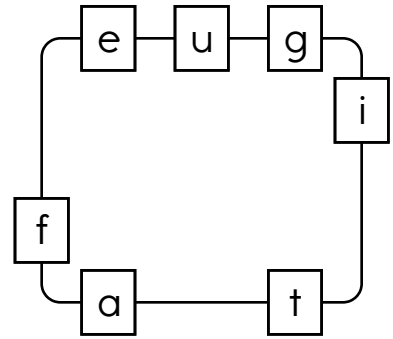

Circle the words.

happiestrollerguttemperorworksloganlighterhoptune
rollersloganhappiestworksloganregurgitategutforest
workhappiesthoptunehappiestlighterhappiestroller

Try to spell some words.

ua • st • ha • ou • gue • pp • ie • fo • ror • ~~gut~~
em • re • loq • pe • st • ci • lea • sly

gut _____

Count by 7s.

77 _____
_____ 154

$\begin{array}{r} 88 \\ - 37 \\ \hline \end{array}$	$\begin{array}{r} 15 \\ + 50 \\ \hline \end{array}$
---	---

5 + = 8 14 + = 35 6 + = 31 5 + = 32

Name: _____

Which way does each word go? Write the word.

<p>1. ↓ CHILDREN → CASH ← COLD</p> <table border="1" style="width: 100%; border-collapse: collapse; text-align: center;"> <tr><td style="width: 10%; height: 20px;"></td><td style="width: 10%; height: 20px;"></td><td style="width: 10%; height: 20px;"></td><td style="width: 10%; height: 20px;"></td><td style="width: 10%; height: 20px;">C</td><td style="width: 10%; height: 20px;"></td><td style="width: 10%; height: 20px;"></td><td style="width: 10%; height: 20px;"></td></tr> <tr><td style="background-color: #cccccc;"></td><td style="background-color: #cccccc;"></td><td style="background-color: #cccccc;"></td><td style="background-color: #cccccc;"></td><td>H</td><td style="background-color: #cccccc;"></td><td style="background-color: #cccccc;"></td><td style="background-color: #cccccc;"></td></tr> <tr><td style="background-color: #cccccc;"></td><td style="background-color: #cccccc;"></td><td style="background-color: #cccccc;"></td><td style="background-color: #cccccc;"></td><td>I</td><td style="background-color: #cccccc;"></td><td style="background-color: #cccccc;"></td><td style="background-color: #cccccc;"></td></tr> <tr><td style="background-color: #cccccc;"></td><td style="background-color: #cccccc;"></td><td style="background-color: #cccccc;"></td><td style="background-color: #cccccc;"></td><td>L</td><td style="background-color: #cccccc;"></td><td style="background-color: #cccccc;"></td><td style="background-color: #cccccc;"></td></tr> <tr><td style="background-color: #cccccc;"></td><td style="background-color: #cccccc;"></td><td style="background-color: #cccccc;"></td><td style="background-color: #cccccc;"></td><td>D</td><td style="background-color: #cccccc;"></td><td style="background-color: #cccccc;"></td><td style="background-color: #cccccc;"></td></tr> <tr><td style="background-color: #cccccc;"></td><td style="background-color: #cccccc;"></td><td style="background-color: #cccccc;"></td><td style="background-color: #cccccc;"></td><td>R</td><td style="background-color: #cccccc;"></td><td style="background-color: #cccccc;"></td><td style="background-color: #cccccc;"></td></tr> <tr><td style="background-color: #cccccc;"></td><td style="background-color: #cccccc;"></td><td style="background-color: #cccccc;"></td><td style="background-color: #cccccc;"></td><td>E</td><td style="background-color: #cccccc;"></td><td style="background-color: #cccccc;"></td><td style="background-color: #cccccc;"></td></tr> <tr><td style="background-color: #cccccc;"></td><td style="background-color: #cccccc;"></td><td style="background-color: #cccccc;"></td><td style="background-color: #cccccc;"></td><td>N</td><td style="background-color: #cccccc;"></td><td style="background-color: #cccccc;"></td><td style="background-color: #cccccc;"></td></tr> </table>					C								H								I								L								D								R								E								N				<p>1. → GOOSE ↓ GRABBED ← GROW</p> <p>2. TRAYS TALK ↓ TURTLE</p> <table border="1" style="width: 100%; border-collapse: collapse; text-align: center;"> <tr><td style="width: 10%; height: 20px;"></td><td style="width: 10%; height: 20px;"></td><td style="width: 10%; height: 20px;"></td><td style="width: 10%; height: 20px;">G</td><td style="width: 10%; height: 20px;">O</td><td style="width: 10%; height: 20px;">O</td><td style="width: 10%; height: 20px;">S</td><td style="width: 10%; height: 20px;">E</td></tr> <tr><td style="background-color: #cccccc;"></td><td style="background-color: #cccccc;"></td><td style="background-color: #cccccc;"></td><td>S</td><td>Y</td><td>A</td><td>R</td><td>T</td></tr> <tr><td style="background-color: #cccccc;"></td><td style="background-color: #cccccc;"></td><td style="background-color: #cccccc;"></td><td style="background-color: #cccccc;"></td><td style="background-color: #cccccc;"></td><td style="background-color: #cccccc;"></td><td style="background-color: #cccccc;"></td><td style="background-color: #cccccc;"></td></tr> <tr><td style="background-color: #cccccc;"></td><td style="background-color: #cccccc;"></td><td style="background-color: #cccccc;"></td><td style="background-color: #cccccc;"></td><td style="background-color: #cccccc;"></td><td style="background-color: #cccccc;"></td><td style="background-color: #cccccc;"></td><td style="background-color: #cccccc;"></td></tr> <tr><td style="background-color: #cccccc;"></td><td style="background-color: #cccccc;"></td><td style="background-color: #cccccc;"></td><td style="background-color: #cccccc;"></td><td style="background-color: #cccccc;"></td><td style="background-color: #cccccc;"></td><td style="background-color: #cccccc;"></td><td style="background-color: #cccccc;"></td></tr> <tr><td style="background-color: #cccccc;"></td><td style="background-color: #cccccc;"></td><td style="background-color: #cccccc;"></td><td style="background-color: #cccccc;"></td><td style="background-color: #cccccc;"></td><td style="background-color: #cccccc;"></td><td style="background-color: #cccccc;"></td><td style="background-color: #cccccc;"></td></tr> <tr><td style="background-color: #cccccc;"></td><td style="background-color: #cccccc;"></td><td style="background-color: #cccccc;"></td><td style="background-color: #cccccc;"></td><td style="background-color: #cccccc;"></td><td style="background-color: #cccccc;"></td><td style="background-color: #cccccc;"></td><td style="background-color: #cccccc;"></td></tr> <tr><td style="background-color: #cccccc;"></td><td style="background-color: #cccccc;"></td><td style="background-color: #cccccc;"></td><td style="background-color: #cccccc;"></td><td style="background-color: #cccccc;"></td><td style="background-color: #cccccc;"></td><td style="background-color: #cccccc;"></td><td style="background-color: #cccccc;"></td></tr> </table>				G	O	O	S	E				S	Y	A	R	T																																																
				C																																																																																																																													
				H																																																																																																																													
				I																																																																																																																													
				L																																																																																																																													
				D																																																																																																																													
				R																																																																																																																													
				E																																																																																																																													
				N																																																																																																																													
			G	O	O	S	E																																																																																																																										
			S	Y	A	R	T																																																																																																																										

$87 + 76 = \underline{\hspace{2cm}}$	Write + or - in the circles. $9 \bigcirc 6 \bigcirc 2 = 6 \bigcirc 5 \bigcirc 10$ $4 \bigcirc 4 \bigcirc 1 = 7 \bigcirc 5 \bigcirc 11$
$17 + \boxed{\hspace{1cm}} = 32$	

$1 \times 11 = \underline{\hspace{2cm}}$	$6 \times 7 = \underline{\hspace{2cm}}$	<input type="radio"/> pini <input type="radio"/> pine <input type="radio"/> pne <input type="radio"/> pinne
--	---	--

$\begin{array}{r} 21 \\ 21 \\ + 24 \\ \hline \end{array}$	$\begin{array}{r} 10 \\ 50 \\ + 29 \\ \hline \end{array}$	$9 \overline{)54}$	$2 \overline{)16}$	$\begin{array}{r} 65 \\ + 77 \\ \hline \end{array}$	$7 \overline{)35}$
---	---	--------------------	--------------------	---	--------------------

Name: _____

Circle words to the RIGHT or DOWN. Every letter is used exactly ONCE.

O F E F S P R F W H A P P I E S T
 E L M E O L L O I G O B Y T U N E F
 X I P N R O A L L U R L E A G U E A O
 C G E J E G N L E T K M A N H O P T R
 I H R O S A T E P E R E N N I A L I B
 T T O Y T N S R I F S H O R T E R G L
 E E R L O Q U A C I O U S N E S S U U
 D R S Y M M E T R I C A L G U Y S E E

Write the words found.

BLUE _____

FATIGUE _____

$\begin{array}{r} 66 \\ + 65 \\ \hline \end{array}$	$\begin{array}{r} 38 \\ + 54 \\ \hline \end{array}$	$\begin{array}{r} 62 \\ + 61 \\ \hline \end{array}$	$\begin{array}{r} 83 \\ + 50 \\ \hline \end{array}$	$\begin{array}{r} 35 \\ - 26 \\ \hline \end{array}$	$\begin{array}{r} 86 \\ - 74 \\ \hline \end{array}$
---	---	---	---	---	---

Write an odd number with an eight in the tens place.

Name: _____

Read the paragraph. Write a topic sentence and supporting details to describe the paragraph.

My favorite kind of puzzle to do is a crossword puzzle. I like crossword puzzles because I like to learn about words. I am patient when I work on a crossword puzzle. My grandma likes crosswords, too. If we get stuck on a word, we look it up in grandma's large dictionary. We are happy when we finish a crossword puzzle!

Write a topic sentence for the paragraph: _____

Write one supporting detail: _____

Write a second supporting detail: _____

Write the hidden word. Start at one letter and then move either left or right.

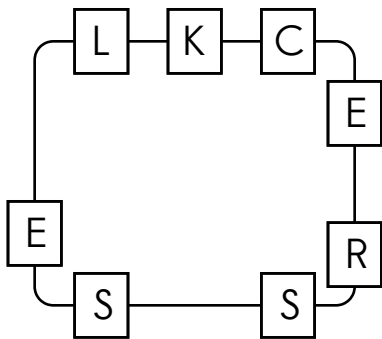

Complete each analogy with the best word.

St. Patrick's Day	February	rainbow
heart	love	Valentine's Day
star	rose	

Santa Claus : Christmas :: _____

Cupid : _____

happiness : smiley face :: _____

love : _____

$19 + \square = 21$	$8 + \square = 34$
---------------------	--------------------

$7 + 1 = \square$	$2 \times 5 = \square$	$14 - 5 = \square$	$11 - 3 = \square$
$9 - 8 = \square$	$11 - 6 = \square$	$1 \times 2 = \square$	$4 + 8 = \square$

Name: _____

Here is an example of shade box addition:

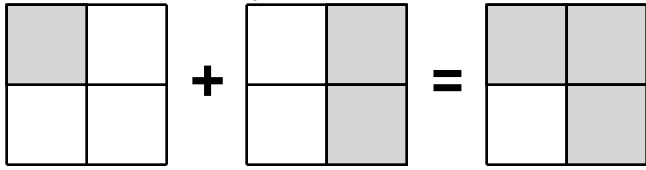

Color the correct squares.

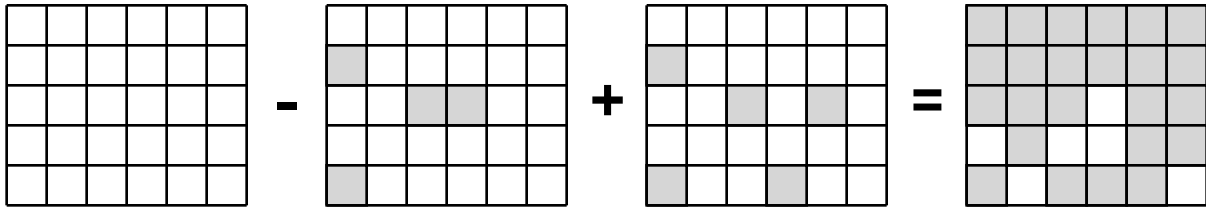

_____ - 4 + 5 = 24

How many syllables does each word have?

bright _____

several _____

froze _____

shy _____

fountain _____

anything _____

grandfather _____

carpet _____

interesting _____

necessary _____

left _____

harbor _____

slippery _____

tomorrow _____

baseball _____

Write a word problem for
 $3 \times 3 = 9$.

Jessica has 22 noodles on her plate. Does she have about 20 noodles or about 30 noodles?

$56 - 42 =$ _____

$99 - 11 =$ _____

$8 + \square = 31$

$17 + \square = 25$

Name: _____

Circle the letters to the word. Write the word.

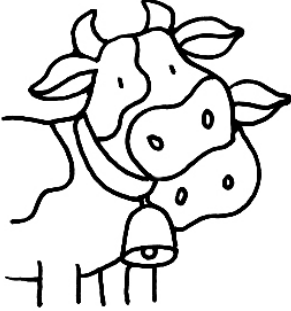

E C T
A T
M E L
J

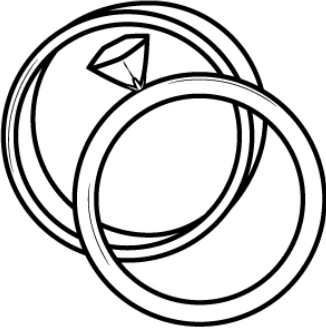

H R
N
I S
R G X



A F M
R T
R

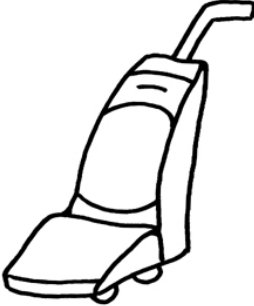

M C
U
A A
N
C
U V
M



E N E
T
W A E



X L N
U
A
M N
A

27, _____, _____, 30, 31, 32,
_____, _____, 35, _____, 37,
_____, _____

60, 80, 100, _____, 140,
160, 180, 200, 220, 240

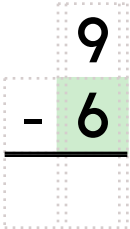

9
- 6

Name: _____

Did you know that you don't always have to use the word **situation** in your writing? Try to use different words for an overused word like **situation**. It will make your work more fun for others to read.

Circle words to the RIGHT or DOWN. Every letter is used exactly ONCE.

J O B C
 E V E N T O
 C I R C U M S T A N C E S E N
 P E P D
 L T I I
 A T S T
 C I O I
 P O S I T I O N E N D O
 O C C U R R E N C E G E N
 O C C A S I O N

Write the words found.

OCCASION	CONDITION	

Write something using the word **situation** at least two times.

Now rewrite your boring writing without using the word **situation**.

I can't wait to read it!

How many words do you think it takes to improve your writing?

Fifty. That's 50! There are about 50 overused words we often use in writing and conversations.

When you find yourself repeating, try something different. It doesn't take much work to sound amazing!

Name: _____

One letter is missing from each word.

F I N A L L Y

D R E R Y

C R A Z

L O E L Y

D V E

D E P R I E

T O M O R R O

A E R T

I S U E

S O E O N E

O U R A G E

Write your own words!

Name: _____

GU Words

GU makes /guh/ sound

G U H G U U H U U U P S M P L
 C G G U S C G O N F E N P I G
 G G E E E G G L P U U I E U U
 N J V N F J U F Q N G U N N T
 G U G S U N P J L G U F M E U
 E D L Y I U L U U U J P N P U
 G P U F U G G U N S G M E N F
 U J G P U G P N I G P E G M U
 M D G U I P S G E G P G G N M
 G G P L U G G U P P I E S U E

GUN • GUPPIES • GUT • FUNGUS
 GULP • GUM

GU makes /gy/ sound

R A U R N R R E U S E U G R A
 U A C A W E I R D F H I A Z R
 G R R E N G G E H I A G Q V G
 E E J C R U Q I E G U R N I S
 R U E L G L U R L U U G I G E
 R E N E V A S E N R I I N A E
 R G U S T R R L R E S U A I A
 G U N S Z S J S R G Y Y G O T
 U G O U R A L U G N A I R T I
 G G L A E L U R R E K R R R R

REGULAR • ARGUES • FIGURE
 TRIANGULAR

Does the "GU" in each word have the gy or guh sound? Circle the sound that "GU" makes.

guppy gy **guh**

figure gy guh

argues gy guh

guppies gy guh

argue gy guh

gulp gy guh

triangular gy guh

regular gy guh

begun gy guh

argued gy guh

gun gy guh

gum gy guh

fungus gy guh

gut gy guh

Name: _____

GU Words

GU Words

gun • guppy • regular • gut • gulp • triangular • fungus • guppies
argued • figure • argues

GU makes /gy/ sound as in argue	GU makes /guh/ sound as in begun	not sure
argues	guppies	
_____	_____	_____
_____	_____	_____
_____	_____	_____
_____	_____	_____
_____	_____	_____

Help! Some of the GU words from this page and the previous page are written like they sound. Can you figure out the real spelling of these words? Good luck.

fuhNGguhs fungus _____

guhpēz _____

ōrgūd _____

ōrgūz _____

fihgur _____

guhlp _____

fuhNGguhs _____

ōrgūz _____

guh _____

guhpēz _____

trīaNGgyuhlur _____

rEHgyuhlur _____

ō kōz → cause

oo choo → chew

ā kāk → cake

ē fēt → feet

ī īs → ice

ō bōt → boat

ū kūt → cute

Name: _____

GU Words

~~knew~~ • nao • persistant • oon • wituot • persistent • on
different • league • onn • legue • in • never • without • new
inn

Jim loved to play baseball. He was the starting pitcher on his team. Everyone _____ town _____ knew _____ about Jim. After each game, people would tell him that he was a great player. Jim was passionate about baseball. He was _____. Even though he was born _____ a right hand, Jim _____ gave up _____ his dream of becoming a major _____ baseball player. Jim Abbott's dream came true! He became a pitcher for the California Angels.

forest • him • firest • hihm • as • cireer • wiold • tongue
~~grandpa~~ • would • figured • tonue • career • wood • aas
fihyurd • thousands • hymn

Grant's _____ grandpa _____ was a famous auctioneer. Grant always loved to watch _____ work because he could talk so quickly! Grandpa's voice tone would go up and down _____ the words rolled off his _____. Grant _____ his grandpa had sold _____ of items throughout his _____. What an exciting job! Maybe Grant _____ follow in his fast talking footsteps.

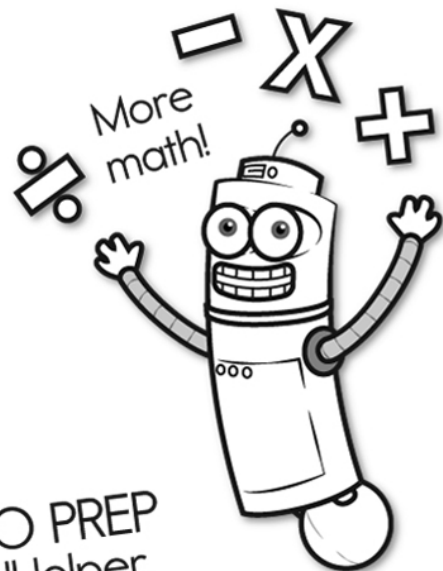
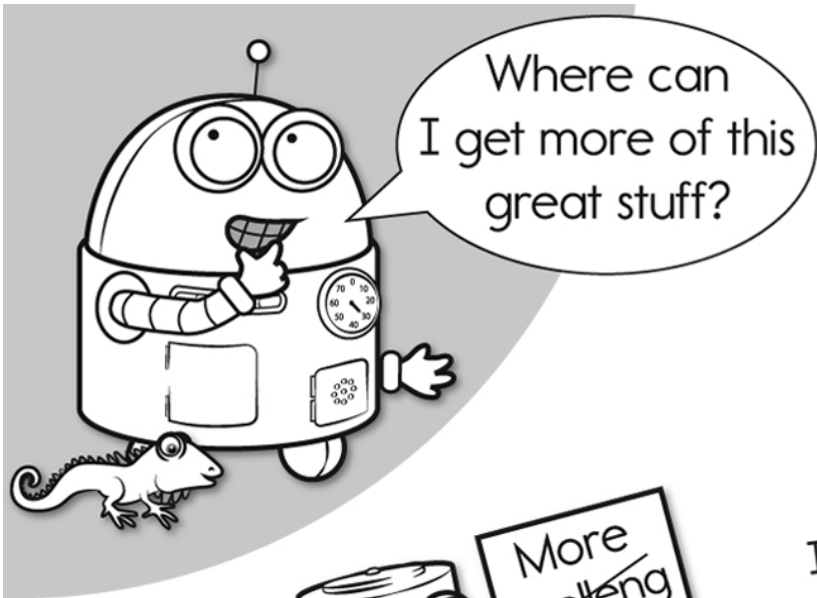

It's NO PREP at edHelper.



edHelper.com!

New online math games!

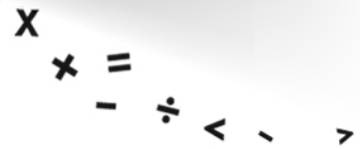
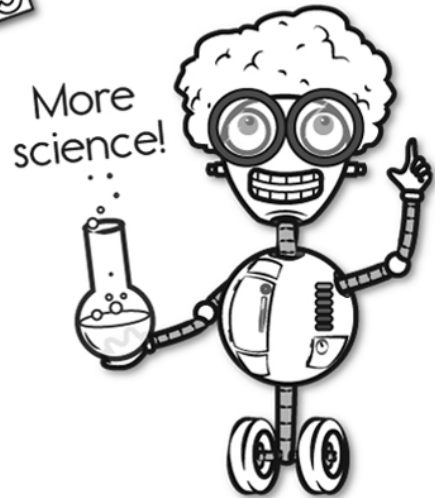
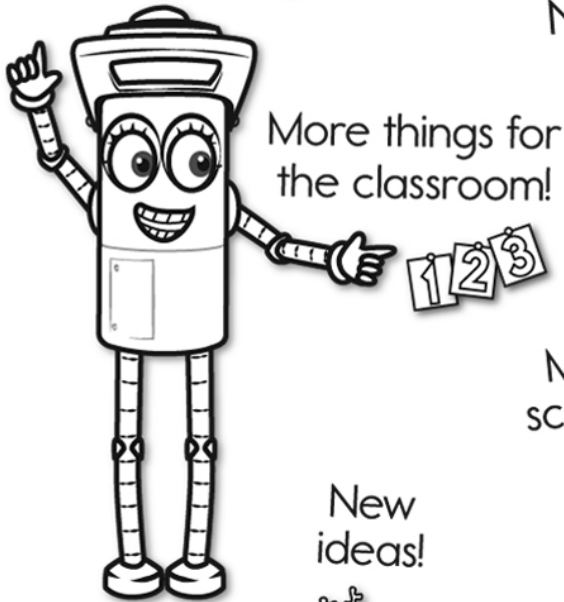

More puzzles!

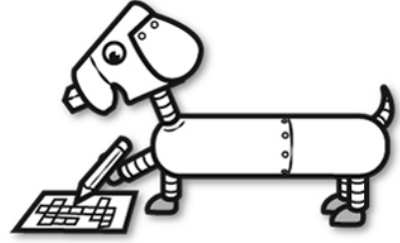

Take The Boring Out Of Homework!

Easy to
print!

edHelper

Weekly K-6 "Take It Home" Books

Kids want choices
for homework.
"Take It Home" books
have fun graphics and
challenging puzzles and
problems for older kids.

"Dr. Programmer"
challenges kids..

Homework
will never be
the same!

edHelper.com

