



UNITED STATES ENVIRONMENTAL PROTECTION AGENCY
WASHINGTON, D.C. 20460

A-98-49
II-A3-24

AUG 11 2000

OFFICE OF
AIR AND RADIATION

Ines Triay, Manager
Carlsbad Area Office
Department of Energy
P.O. Box 3090
Carlsbad, NM 88221

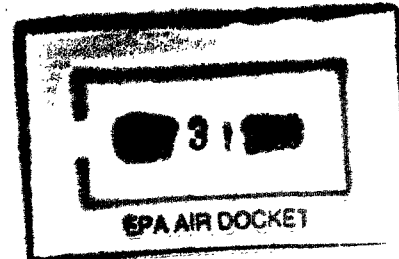

Dear Dr. Triay:

Thank you for your letter dated June 26, 2000, in which you notified us of your intent to raise the Waste Isolation Pilot Plant's repository horizon in Panels 3, 4, 5, 6, and 9 by approximately two meters so that the roof is located at Clay Seam G. My staff have reviewed your plan, and we agree that it will enhance operational safety without significantly affecting the long-term performance of the facility. A summary of our technical review is enclosed for your information. We will place this summary in our docket.

If you have any questions regarding the summary, please call Mary Kruger at (202) 564-9310.

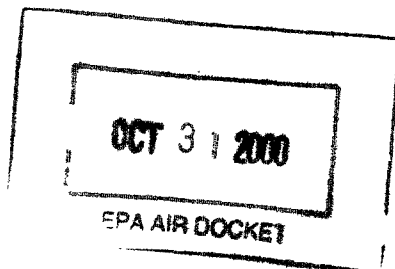

Sincerely,

Frank Marcinowski, Acting Director
Radiation Protection Division

Enclosure

cc: Matthew Silva, EEG

Summary: EPA Review of Clay Seam G Mining Plan

1.0 Introduction

This report summarizes our consideration of a DOE plan to elevate the excavation of several new WIPP waste panels (3-6 and 9) such that the roof coincides with Clay Seam G. This plan was presented to EPA in a letter from Dr. Ines Triay, dated June 26, 2000, and during a technical meeting between EPA and DOE held in Carlsbad, New Mexico, on June 28 and 29, 2000.

2.0 Summary of DOE Plan

The current panel elevation results in a 2-meter thick beam of halite between the roof and Clay Seam G. Clay Seam G is thin but continuous and provides a layer with essentially no shear or tensile strength. This beam is subjected to considerable lateral loading. It tends to bend downward into the excavated room, fracture, and separate from the rest of the halite along the clay seam. Extensive rock bolting and maintenance are needed to maintain safe working conditions over extended periods of time. DOE plans to raise the entire panel excavation approximately 2 meters, so that the roof would coincide with Clay Seam G and the floor would be an additional 2 meters above Marker Bed 139. This plan would retain the current panel dimensions and waste loading.

The plan would increase the roof stability by allowing the upper room sidewall to move more freely toward the room along Clay Seam G, decreasing the load on the roof and transferring most of the lateral load to the floor, where buckling may occur but collapse would not. The primary benefits of this change would occur during the operational period. Eventually the salt would deform and encapsulate the waste in the same manner as for the current design. DOE does not expect that increasing the elevation of the waste panels by about 2 m will significantly affect long-term repository performance.

3.0 Assessment of DOE Plan

DOE's plan is justified based on the wealth of mining experience at the WIPP. The plan offers clear advantages to the miners during the operational phase. For example, on June 29 we were shown excavations at the salt handling shaft station where the roof had been raised to Clay Seam G about 5 years after original mining. These excavations were relatively stable, with no large scale fracturing, in contrast with the severe buckling that could be seen in rooms mined below Clay Seam G. A DOE report completed in 1994 describes Room D, where the roof was originally excavated to a continuous clay seam and where enhanced stability has been observed. This report also states, "Without exception, the field data demonstrate that initially mining drifts with a clay seam forming the roof makes for long-lasting, stable excavations. The field data also demonstrates that removing a roof beam well after excavation improves the stability of a drift."

(DOE-WIPP 94-025, "Investigation of the Advantages of Removing Highly Fractured Roof Beams," August 1994, p. 9).

These results are supported by numerical modeling, which shows a transfer of lateral stresses to the floor (DOE-WIPP 94-025, Figure 25). Although the strain in the corner between the floor and the sidewall considerably increases, the resultant fracturing is at the floor and is not considered hazardous, because it can be readily supported if needed in the same manner as the fractured halite presently observed at the corners of drift intersections.

The impacts of the plan on long-term repository performance appear minimal and are not expected to affect compliance adversely, as discussed below.

3.1 Probability of Borehole Intersection

The disposal panel dimensions and waste loading procedures will remain unchanged. The probability of intersecting the repository by an exploration borehole will therefore also remain unchanged, as will releases due to cuttings and cavings.

3.2 Spalling Releases and Direct Brine Releases

The affected waste panels would be approximately 2 m nearer the ground surface, possibly resulting in slightly lower borehole drilling fluid back pressure, slightly lower in situ rock stresses due to reduced overburden loading, and slightly lower pore water pressures. Such changes could result in minor changes in spillings releases, direct brine releases, repository gas pressures, and brine flows into and out of the repository. Some of these changes may be slightly adverse and some may be slightly beneficial; however, the change in elevation relative to the 655 m (2150 ft) total depth of the facility is only 0.3%. The effect of such a small room elevation change would have a negligible effect on long-term performance and should be well within the uncertainty of the calculations.

3.3 Castile Brine Reservoir

The height of the affected waste panels above a hypothetical Castile brine reservoir will be increased by approximately 2 m. This increase could result in slightly lower brine flows into the repository if such a reservoir were encountered due to the increased hydraulic head. This change may be slightly beneficial; however, the change in elevation relative to the approximately 259 m (850 ft) depth of brine reservoirs beneath the repository is only 0.8%, and the effect of such a small room elevation change would have a negligible effect on long-term performance.

3.4 Marker Bed 139

The distance between the affected waste panels and underlying Marker Bed 139 would be increased by about 2 m. The halite in this interval may continue to be included in the disturbed

rock zone (DRZ) in PA modeling because the increased distance would be offset by an increased lateral load. This marker bed averages about 2.8 feet thick and is the primary avenue for interbed flow into and out of the repository. Raising the waste panels by 2 m would approximately double the distance between the panel floor and Marker Bed 139 and could provide a small beneficial effect by decreasing brine flow between the panel and the marker bed.

3.5 Clay Seam F

Raising the waste panels would lower the height of Clay Seam F on the room walls. This change may be slightly adverse because it will allow the sidewalls to move more freely into the rooms. This movement will not affect long-term performance. Because Clay Seam F is dispersed rather than continuous, the operational difficulties posed by sidewall movement would not be severe and would be offset by the benefits gained by reducing the roof beam load.

3.6 Roof Rock Bolts

An increased stability of the roof would result in the use of fewer rock bolts, fewer short boreholes penetrating the roof, and less iron available for corrosion. These effects, although small, would be generally beneficial.

3.7 Floor Loading

The increase in the floor beam load would likely increase buckling and heaving of the panel floors. This movement will not affect long-term performance. Fractured and loosened halite in the floors does not present the same safety hazard as loosening in the roof because halite in the floors will not cause injuries by falling. Floor buckling can be addressed by removing the halite, thereby maintaining the design room height.

3.8 Room Sidewalls

As previously mentioned, strain at the edge of a waste panel where the floor and the sidewall meet would be increased, and increased fracturing may occur on the lower sidewalls. The resultant fracturing will be near the floor and is not hazardous because it can be readily supported with wire mesh in the same manner as the fractured halite presently observed at the corners of drift intersections. It will not affect long-term performance.

3.9 Anhydrite Layer B

Anhydrite layer B lies just above Clay Seam G. This anhydrite layer presently intersects the DRZ above the waste panel. Raising the waste panels would cause this anhydrite layer to directly intersect an affected waste panel at the roof. The anhydrite would be removed during mining because it may represent an operational safety hazard. The long-term effect of directly intersecting this anhydrite will be negligible because the layer is thin and not laterally extensive.

Anhydrite layer B is only about 0.2 ft thick, as compared with thicknesses of 0.7 ft for anhydrite layer A, 0.7 ft for Marker Bed 138, and 2.8 ft for Marker Bed 139. Anhydrite layer B accounts for less than 5% of the total thickness of anhydrite interbeds located near the repository.

In current PA modeling, all four anhydrite layers are conservatively assumed to be regionally extensive and intersect the repository DRZ. They are therefore already connected with the waste panels by a relatively high permeability pathway. Anhydrite layers A and B are not considered marker beds because they are not regionally extensive. Because it is thin and not laterally extensive, the direct intersection of anhydrite layer B and Clay Seam G may result in a small predicted increase in brine flow into the repository, but not enough to affect long-term performance significantly. In most PA runs, the available brine was entirely consumed by iron corrosion and small increases in brine inflows would have made little difference.

3.10 Marker Bed 138

Raising the waste panels would bring the roof 2 m closer to Marker Bed 138, reducing the distance by 18% from about 11 m to 9 m (this distance varies from panel to panel). However, Marker Bed 138 is already interconnected with the repository through the relatively high permeability DRZ, and small increases in flow from this marker bed would be more than offset by decreases in flow from Marker Bed 139. A generalized stratigraphic column provided by DOE at the June technical meeting indicates that there are no other marker beds within 30 ft above Marker Bed 138.

4.0 Conclusions

We have identified no significant impacts that would adversely affect the WIPP' long-term performance. DOE's plan to raise the elevation of certain WIPP waste panels in the future is likely to bring significant benefits for mining operations.

Attachment 1

Letter to EPA from DOE



Department of Energy

Carlsbad Area Office
P. O. Box 3090
Carlsbad, New Mexico 88221

June 26, 2000

Mr. Frank Marcinowski
Office of Radiation and Indoor Air
Environmental Protection Agency
Center for Federal Regulation
Ariel Rios Building
1200 Pennsylvania Avenue, N. W.
Washington, DC 20460

Dear Mr. Marcinowski:

The purpose of this letter is to inform the Environmental Protection Agency that the Carlsbad Area Office (CAO) plans to raise the repository horizon in Panels 3, 4, 5, 6, and 9 by approximately two meters so that the roof is at clay seam G. The Waste Isolation Pilot Plant intensively monitors the geomechanical behavior of its underground excavations. Actual monitoring of underground excavations, specific underground studies, and geotechnical modeling (e.g., DOE-WIPP 94-025, Investigation of the Advantages of Removing Highly Fractured Roof Beams), all demonstrate that positioning the roof at clay seam G improves ground conditions in the repository and provide a more stable roof configuration without significantly impacting repository performance. Raising the repository horizon reduces the rate at which ground deteriorates (i.e., slower roof beam deformation rate and slower development of fractures), thus reducing risks during mining and waste handling operations.

The repository horizon for Panels 3, 4, 5, 6, and 9 will be raised so that the roof is at clay seam G (shown on the attached Figure 3-6). Raising the repository horizon will be initiated in the East 300 drift (shown on the attached Figure 3-2) which leads into Panel 3. Raising the repository horizon now and in this location will result in improvements in safety and in operational efficiencies. This does not imply that there are underground safety concerns associated with the present situation; however, by raising the repository horizon by about two meters, ground conditions will be improved and considerably less maintenance will be required to assure optimum ground conditions.

CAO has analyzed (qualitatively) the impacts of moving the repository horizon on the long-term performance predictions in the certified baseline. The change in horizon may have some small impacts on brine inflow, gas/brine outflow, and creep closure. However, these impacts are



June 26, 2000

expected to be quite small and may only be observable, if observable at all, in the subsystem performance assessment (PA) computer codes. More importantly, it is expected that there will be an insignificant impact on the location of the Complementary Cumulative Distribution Function (CCDF) curve for the PA that was included in the Compliance Certification Application (CCA) and the Performance Assessment Verification Test. This insignificant impact on the CCDF is expected because of the simplifications and conservative assumptions (e.g., treatment of the disturbed rock zone (DRZ) and panel closure permeability) made in the PA-scale computer models regarding the repository horizon and long-term performance of the disposal system. This change in repository horizon is within the disposal horizon envelope presented in the CCA in Figure ES-1 of Appendix Panel Closure System (PCS) and in Figure 3-6 from Chapter 3.

Based on the demonstrated geotechnical improvements (i.e., slower roof beam deformation rate and slower development of fractures) and the insignificant impact on the long-term predictions for repository performance, as a result of raising the horizon, the CAO will begin the mining at the slightly elevated repository horizon on or about July 1, 2000. CAO is tentatively scheduled to provide technical discussions to the EPA staff on this improvement and other topics during the week of June 26th, 2000 in Carlsbad New Mexico.

Enclosures to this letter provide additional information on this item. If you have any questions, please contact George Basabilvazo at 505-234-7488.

Sincerely,

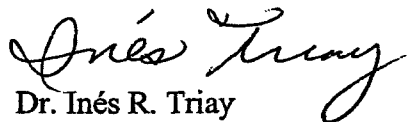
Dr. Inés R. Triay
Manager

Enclosures:

- A: Figure 3-2 from CCA Chapter 3
- B: Figure ES-1 from CCA Appendix PCS
- C: Figure 3-6 from CCA Chapter 3
- D: Report DOE-WIPP 94-025, Investigation of the Advantages of Removing Highly Fractured Roof Beams

Mr. Frank Marcinowski

- 3 -

June 26, 2000

cc w/ enclosures:

M. Kruger, EPA-ORIA

✓ C. Byrum, EPA Region 6

cc w/o enclosures:

D. Huizenga, EM-20

C. Zvonar, CAO

G. Basabilvazo, CAO.

B. Lilly, CAO

F. Hansen, SNL

B. Howard, SNL

M. Marietta, SNL

D. Haar, WID

D. Kump, WID

W. Most, WID

00 JUN 30 PM 12:31
RCRA PERMITS PROGRAM

CAO:ORC:GTB 00-0090
UFC 6500

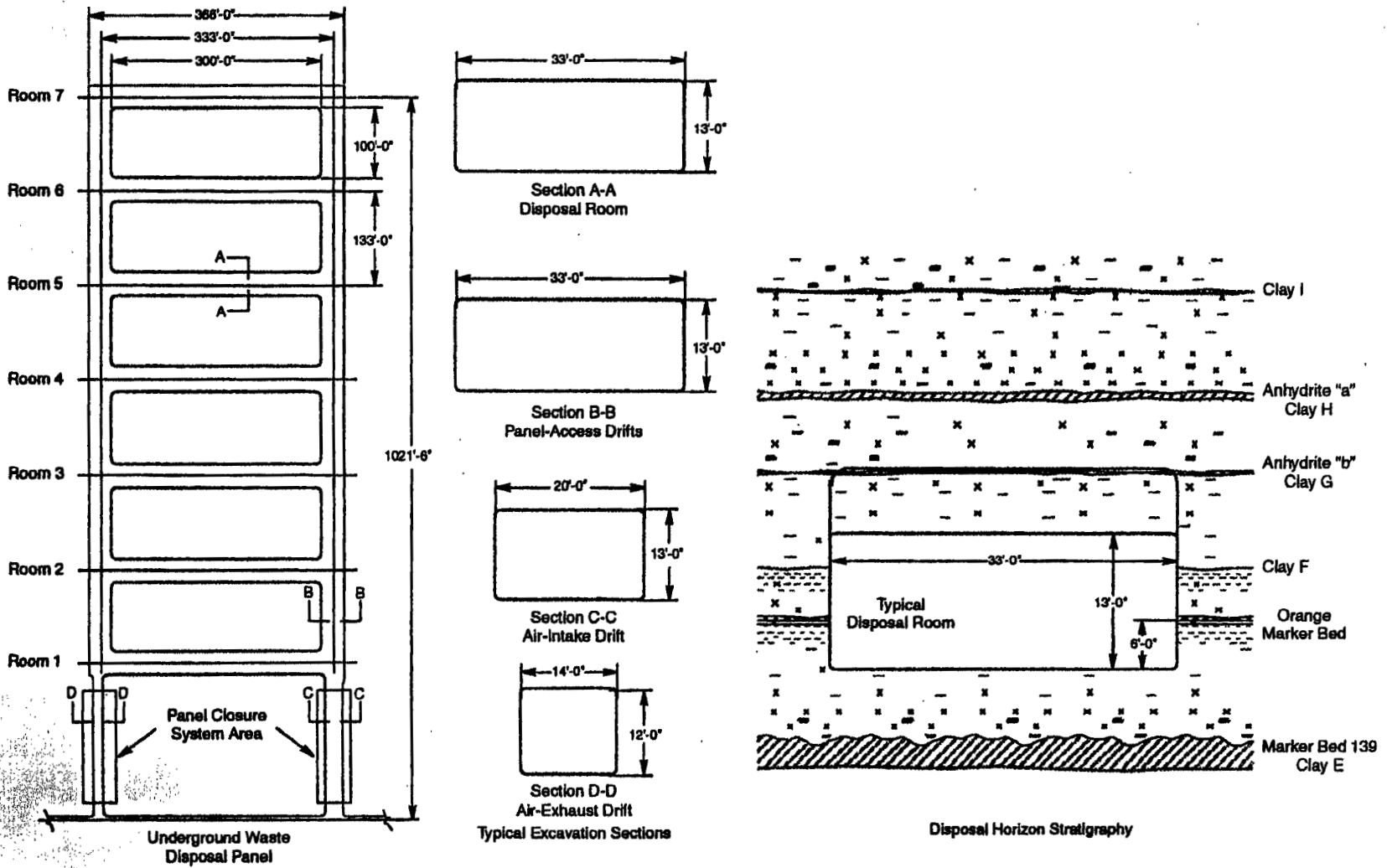

Note: Figure is not to scale. All dimensions shown are nominal.

Figure 3-6. Location of Panel Closure System

CCA-089-2

Title 40 CFR Part 191 Compliance Certification Application

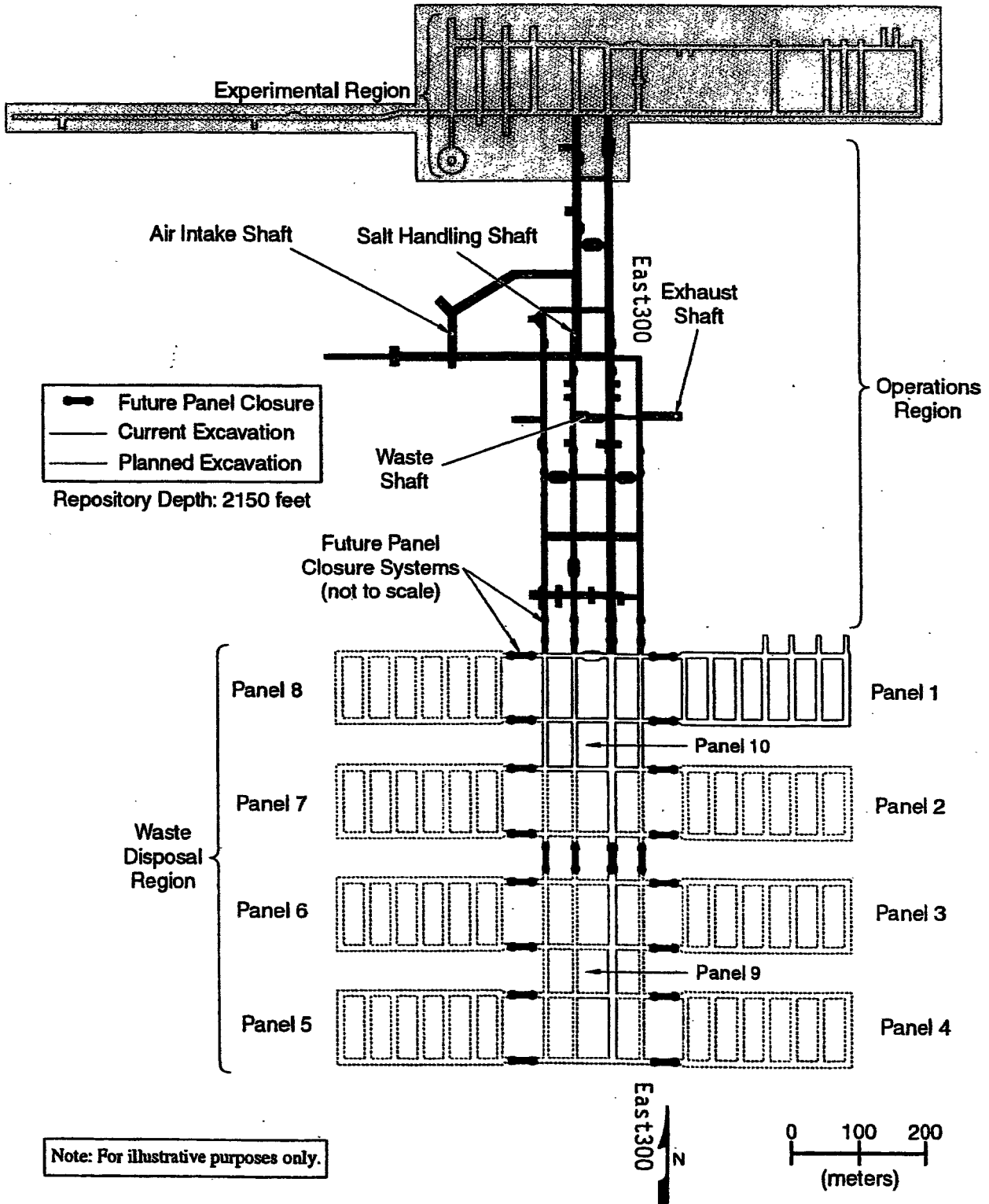
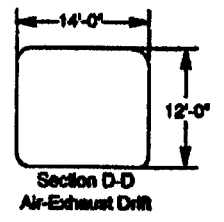
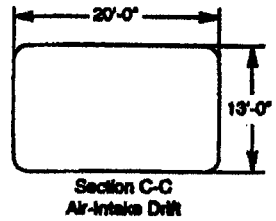
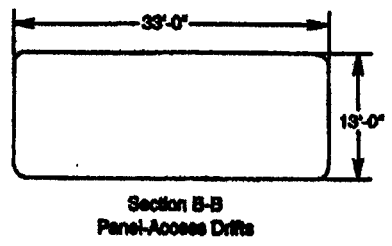
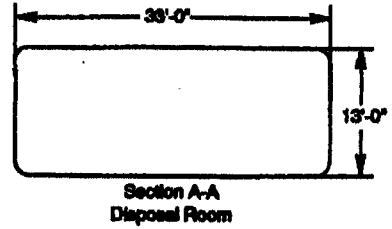
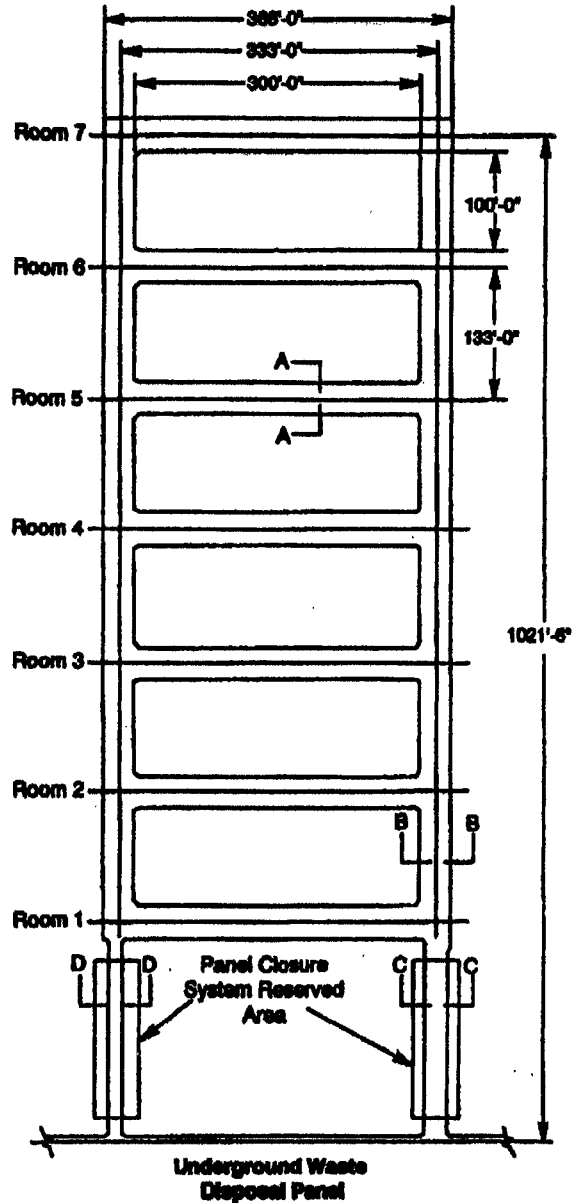

Figure 3-2. Plan View of WIPP Underground Facility and Panel Closure Systems

Enclosure B

7/26/17 04.05.00.0018 AM

ES-2



Typical Excavation Sections

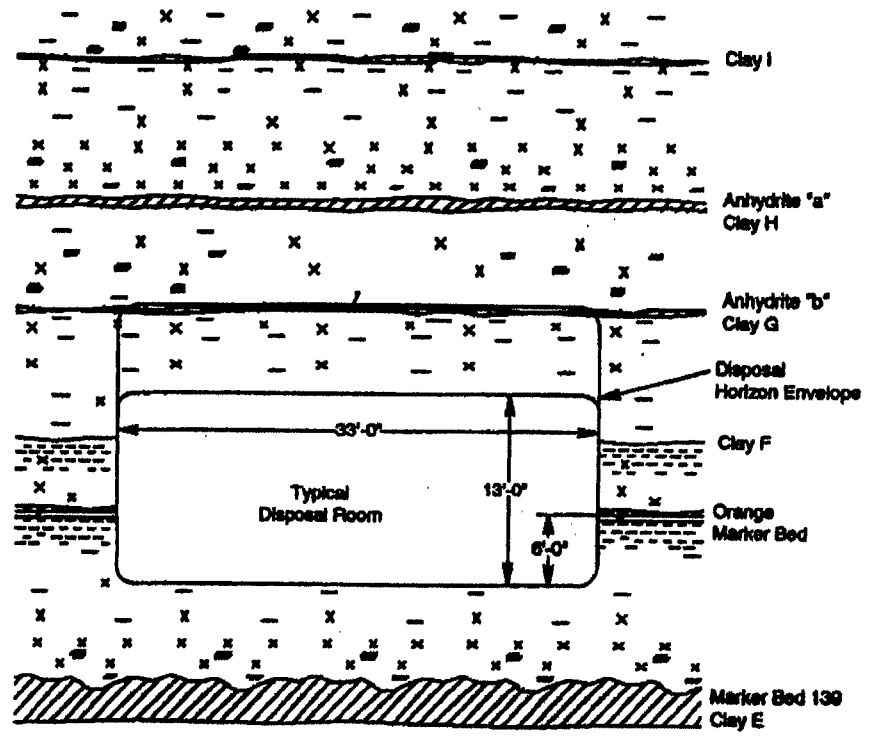

Disposal Horizon Stratigraphy

*Note: Figure is Not to Scale
All Dimensions Shown are Nominal*

**Figure ES-1
Typical Facilities-Typical Disposal Panel
(After Westinghouse, 1995c)**

10/16/18

Attachment 2

Handouts from the June 2000 Technical Meeting

WIPP REPOSITORY ROOF POSITION - GEOMECHANICAL CONSIDERATIONS

EPA Informational Meeting

Carlsbad

28-29 June 2000

*Stan
Patch et
al*

(B)

WIPP Geomechanical Program

- **Ensure operational safety and the protection of human health and the environment**
- **Continuous assessment of excavation performance**
- **Extensive 'insitu' measurements**
- **Reasonable variety of dimensions and horizons**
- **Extensive state-of-the-art computer modeling**
- **Regular publication of work in a variety of fora and media**

Conceptual Model of Excavation Deformation and Failure

- **Excavation mined** *Jones*
- **Excavation deforms smoothly by creep** *based on overburden*
- **Fractures begin to develop**
- **Fractures cause local concentration of deformation**
- **Fractures become continuous**
- **Fractures become pervasive**
- **Separated material falls under gravity**

WIPP Stratigraphy

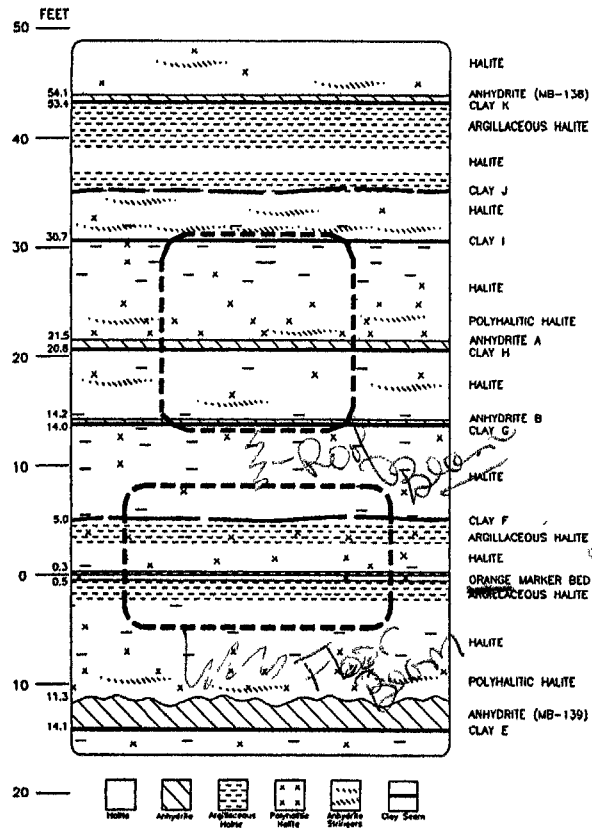

*Great excavations
 1000 sq ft
 Orange marker bed*

Impact of Stratigraphy

- **Clay seams act as planes of weakness in tension and shear**
- **Pillars move horizontally, sliding on clay seams in roof and floor, effectively concentrating pillar lateral deformation into the immediate roof and floor beams**

East 140 at S1368

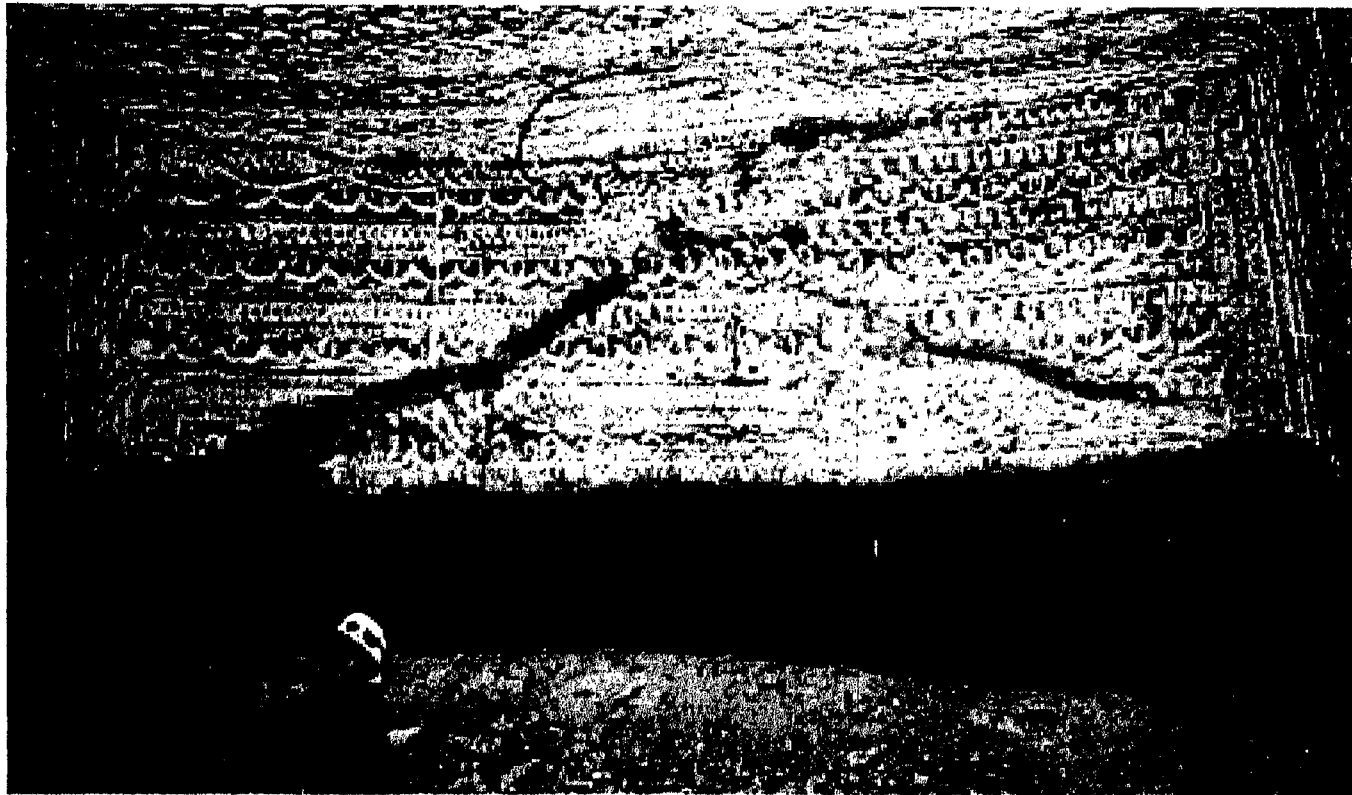

Observation and Measurement

- **Visual observations, both on the surface of excavations and within boreholes, qualitatively confirm this behavior pattern**
- **Measurements, such as borehole extensometers and lateral displacement meters, quantitatively confirm both the separation and sliding modes of deformation**

EEP Array - SPDV Room 2

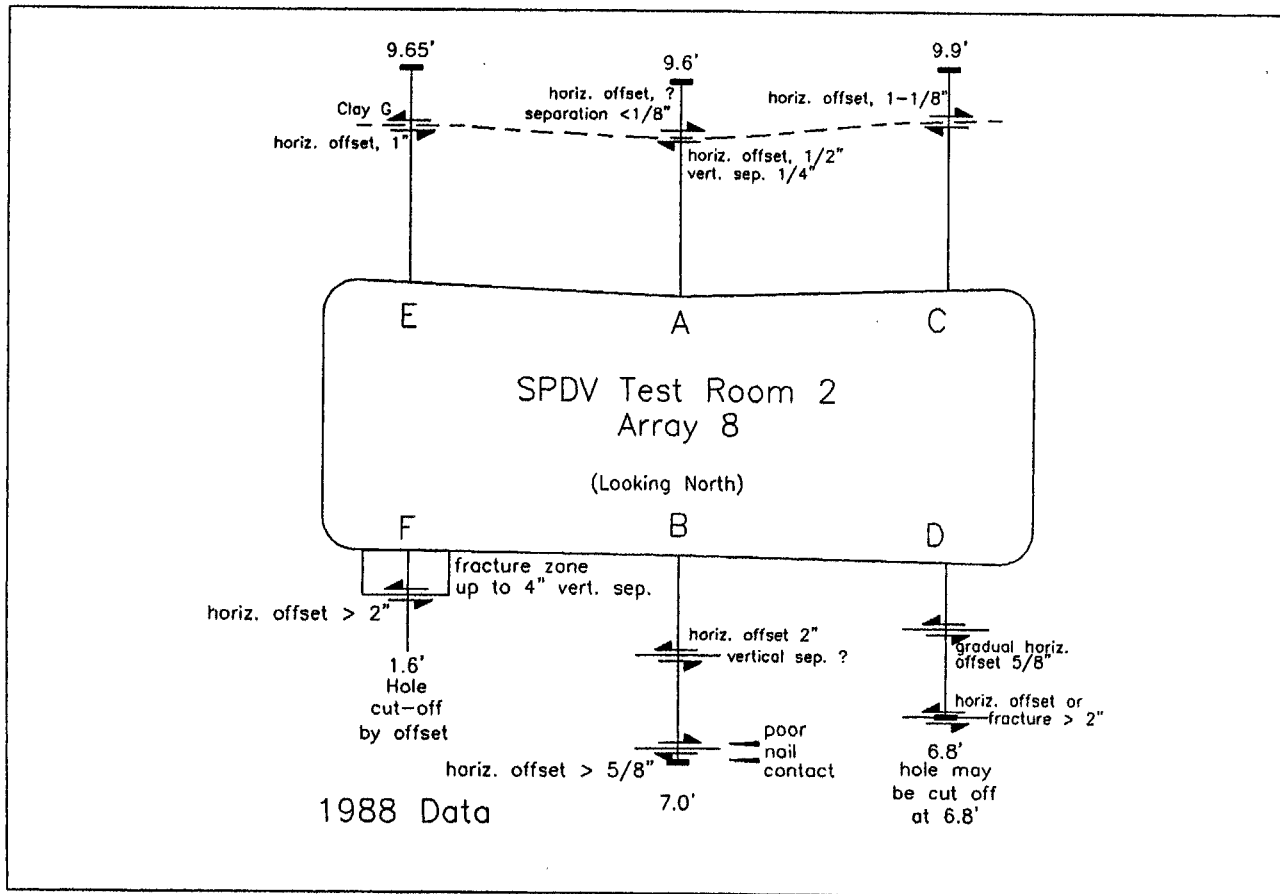

SPDV Room 2 Extensometer

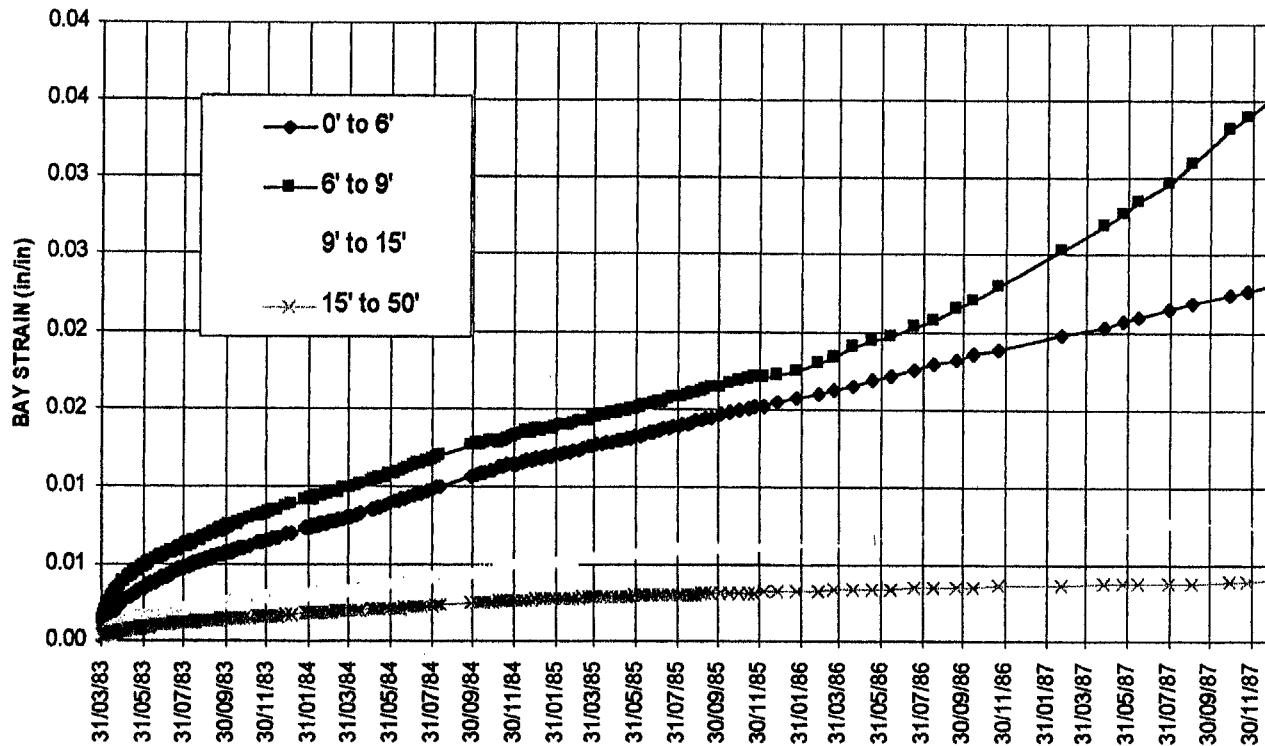

Field Observations

- **Salt Handling Shaft station**
- **Drifts mined with roof at a clay seam**
- **SPDV Rooms**
- **East 140 roof beam removal**

North 1100

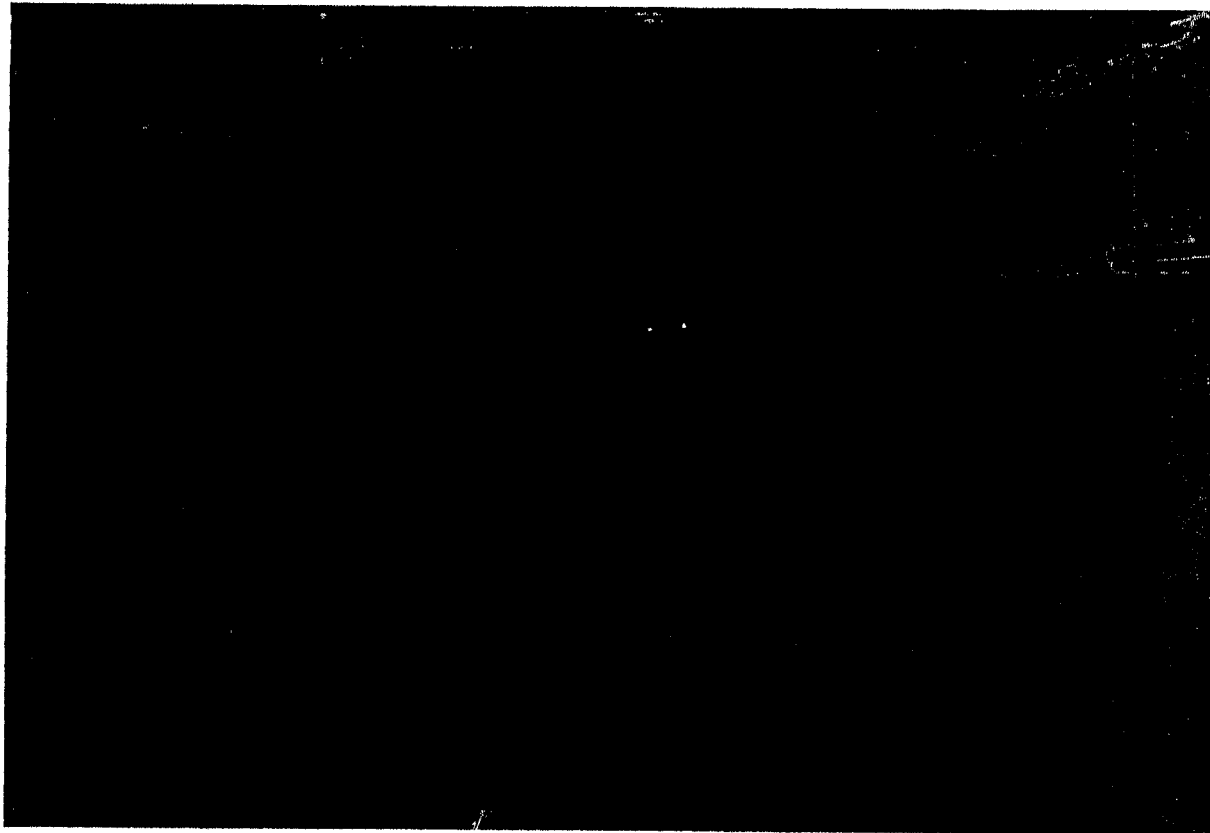

1982-83
2000

East 140 Roof Beam Removal



Sketch of Fractures at E140/S1508

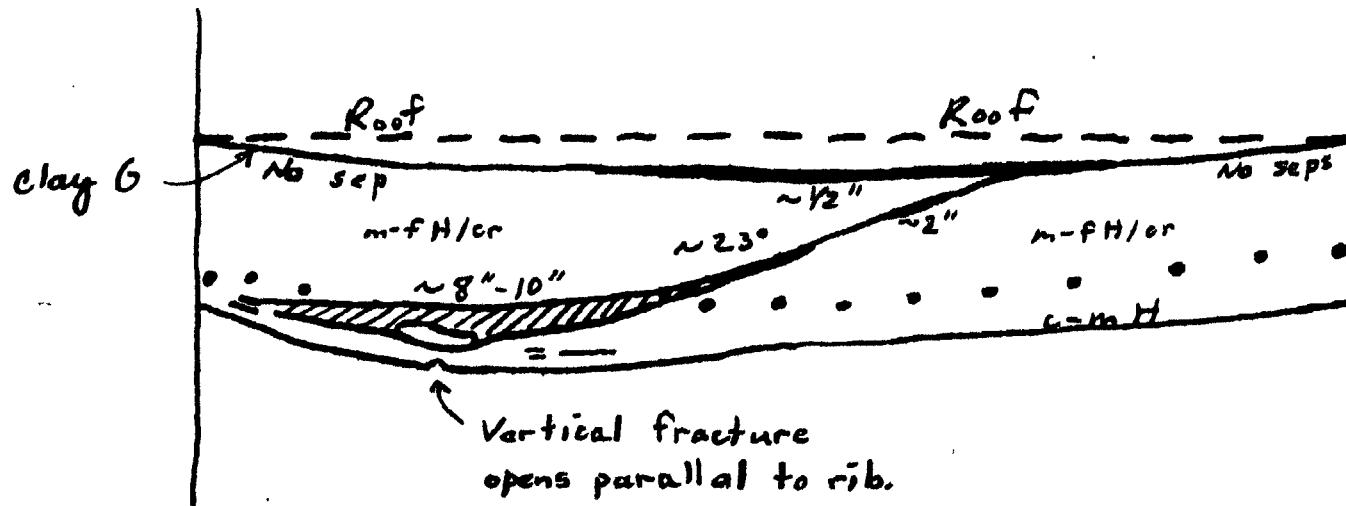

Numerical Analyses

- **Developments are rapid and extensive**
 - software**
 - hardware**
- **Use State-of -the Art techniques and methods**
- **Strict QA/QC**
 - Verify using different codes**
 - Validate against known, measured ‘insitu’ behavior**

Two-Dimensional Models - Routine Use

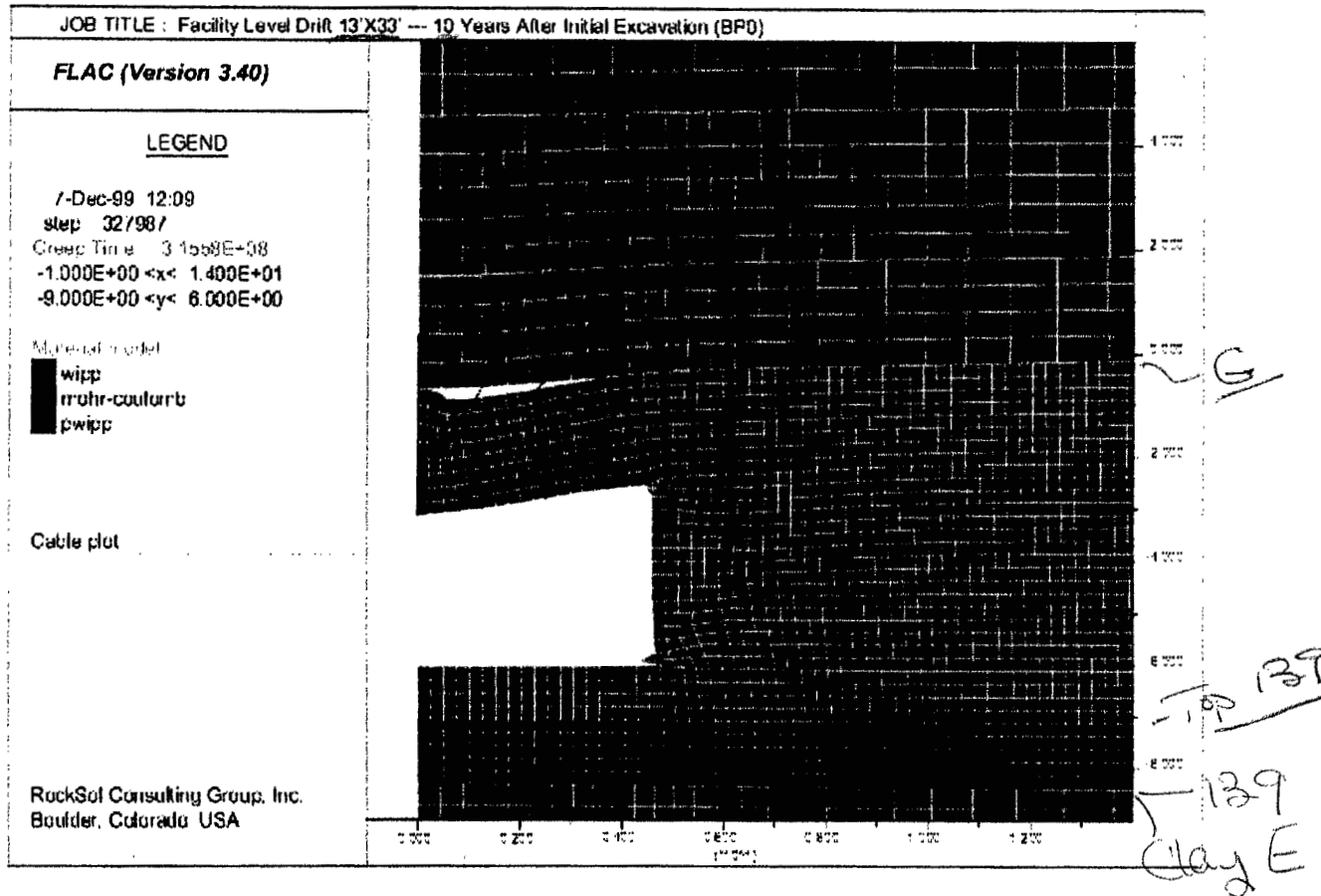

Three-Dimensional Models - Regular Use

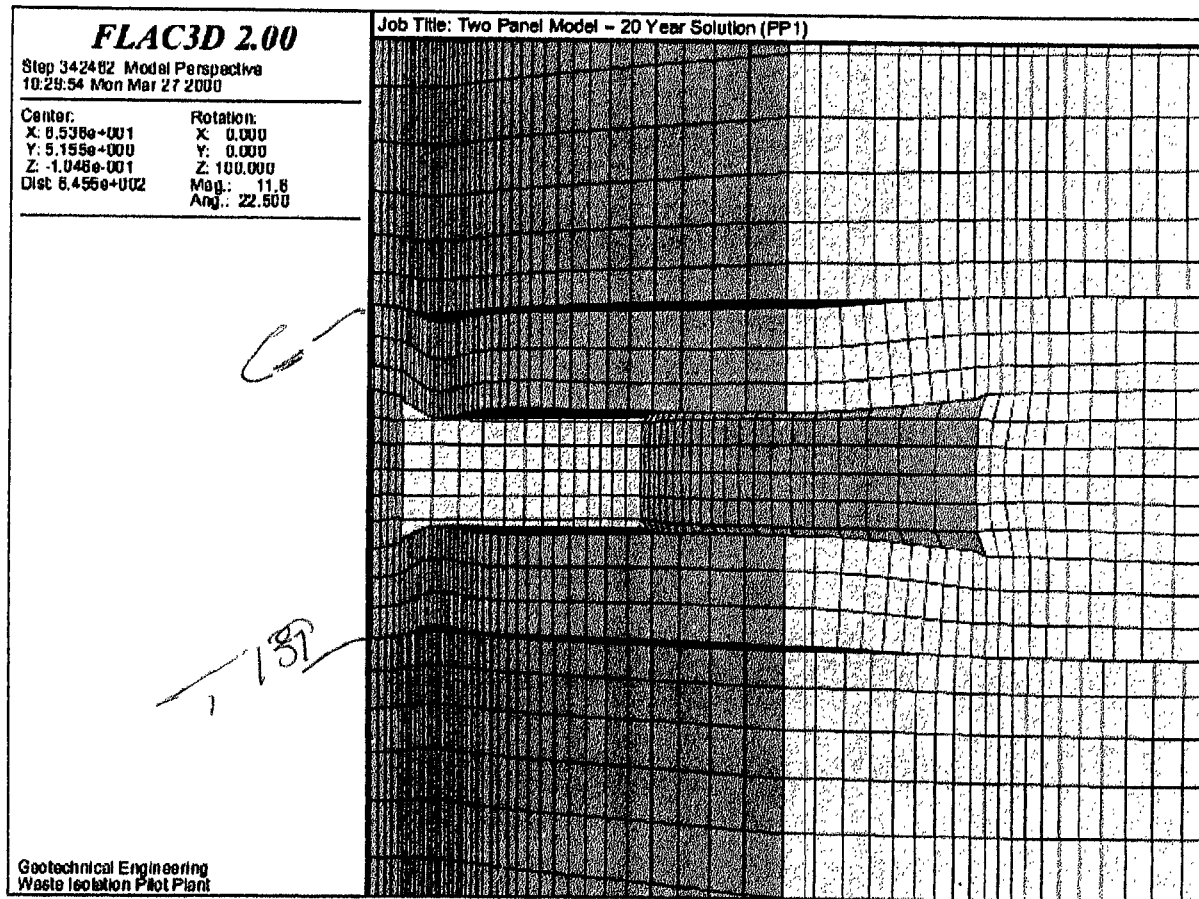

Fracture Models - Under Development

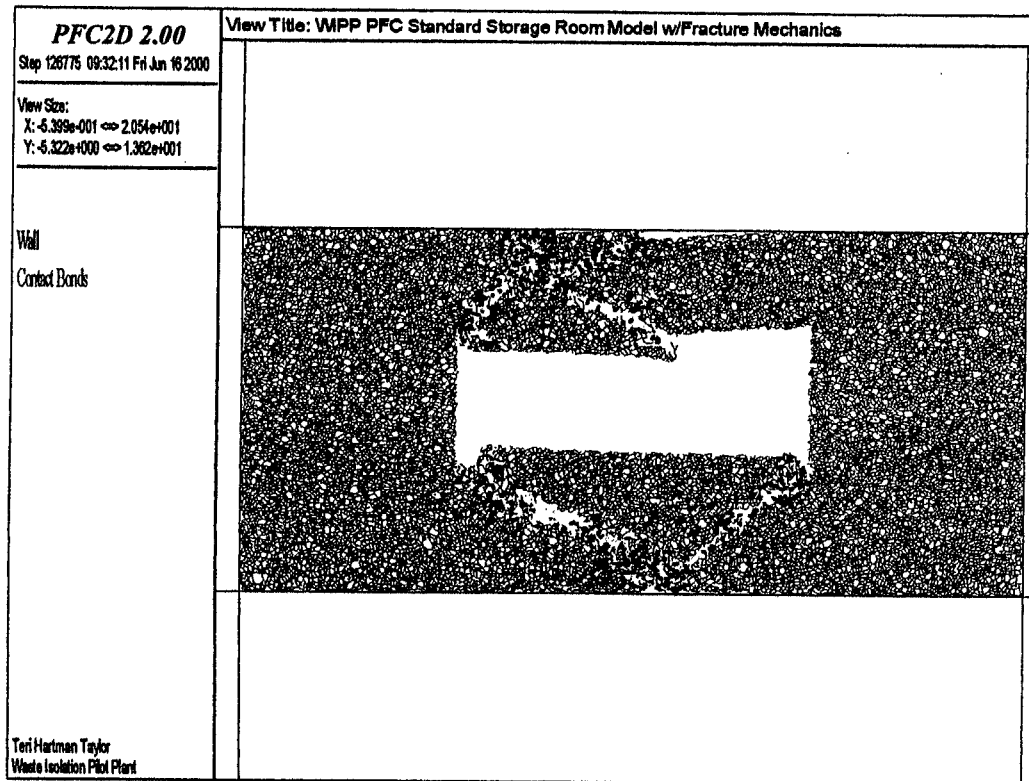

Operational Considerations

- + **Simplifies excavation sequence**
- + **Increases confidence in roof behavior**
- + **Reduces Disturbed Rock Zone ***
- + **Potentially simpler panel closure with *
improved performance**
- - **Increases rib deformation and
consequent scaling**

Conclusions

- **Present horizon is safe and acceptable, but process improvement is continuous**
- **Known deformation and fracture patterns**
- **Moving excavations up to next clay seam improves confidence in excavation performance, especially those with longer lives**
- **Operational efficiencies can be achieved with no additional costs**



Clay G

PA/CCA Impacts

Frank Hansen
June 28-29, 2000



**Sandia
National
Laboratories**

EPA Meeting

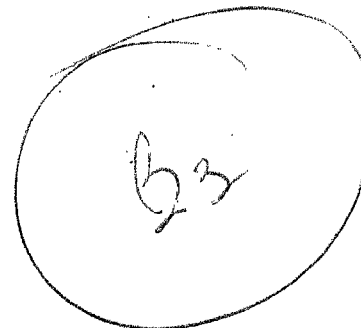



- Performance Assessment impact of raising repository horizon
 - Room & Panel dimensions remain the same; back to be located at clay G, floor to be positioned to maintain baseline room geometry
 - New location within the disposal horizon envelope presented in the CCA Figure ES-1 from Appendix PCS



- Performance Assessment impact of raising repository horizon
 - The avoidance of clays and anhydrites was one criterion used in the selection of the current repository horizon. It was assumed that Salado near-field salt would encapsulate waste
 - As the WIPP experimental program evolved, PA assumptions were modified such that DRZ persists through time and extends to MB 138, some eight meters above clay G and to MB139, some two meters below clay G



• Anticipated Results

- Based on the modeling assumptions, there may be more water “squeezed” out of clay G and minor differences in gas/brine outflow and mechanical modeling as compared to the CCA/PAVT
 - Modeling results indicate that a significant part of the calculated brine inflow is actually from excavation induced DRZ, rather than far-field inflow
 - Models for brine inflow/outflow and actinide source term models already include connection of the repository with the overlying and underlying anhydrites

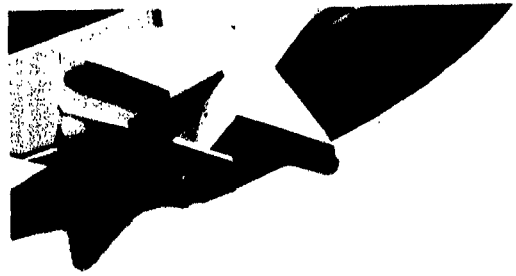

- **Anticipated Results**

- Based on an qualitative analysis, extra brine from clay G and perhaps minor differences in gas/brine inflow & modeling will have no significant impact on repository performance.



- **Anticipated Results**

- **Potential impacts on calculational environment**

- **The BRAGFLO grid dimensions (elements and material regions) around the panels will be slightly different**
- **If there would be any observable differences in brine inflow or outflow, it might be seen in subsystem results (BRAGFLO horse tail plots) and not in the CCDF**
- **Given the simplification and conservative assumptions made in PA-scale models regarding interconnections of the repository horizon and adjacent anhydrites, the numerical impacts of moving the repository would likely be insignificant (not even perceptible)**



- **Baseline Concerns: FEPs and Conceptual Models**
 - **FEP:SCR.2.1.1 Repository Characteristics**
 - » The WIPP repository disposal geometry is accounted for in CCA PA calculations. SANTOS model used to create a porosity surface.
 - » Conceptual Model: Disposal System Geometry
 - **FEP:SCR.2.3.1 Excavation-Induced Fracturing**
 - » Operational improvements noted; however, the conceptual model for induced fracture for elevated panels is unlikely to be substantively different than an appropriate model for Panel 1.
 - » Conceptual Model: DRZ/constitutive model
 - **FEP:SCR.2.3.2 Salt Creep**
 - » Changes 2M of salt from roof to floor



- **Summary**

- **Qualitative Assessment Results**

- **Moving the repository horizon 2 m is not a significant change from the CCA baseline**
- **Detailed predictions of long-term behavior would not be expected to change**

- **Insignificant impact on the long-term predictions for repository performance**

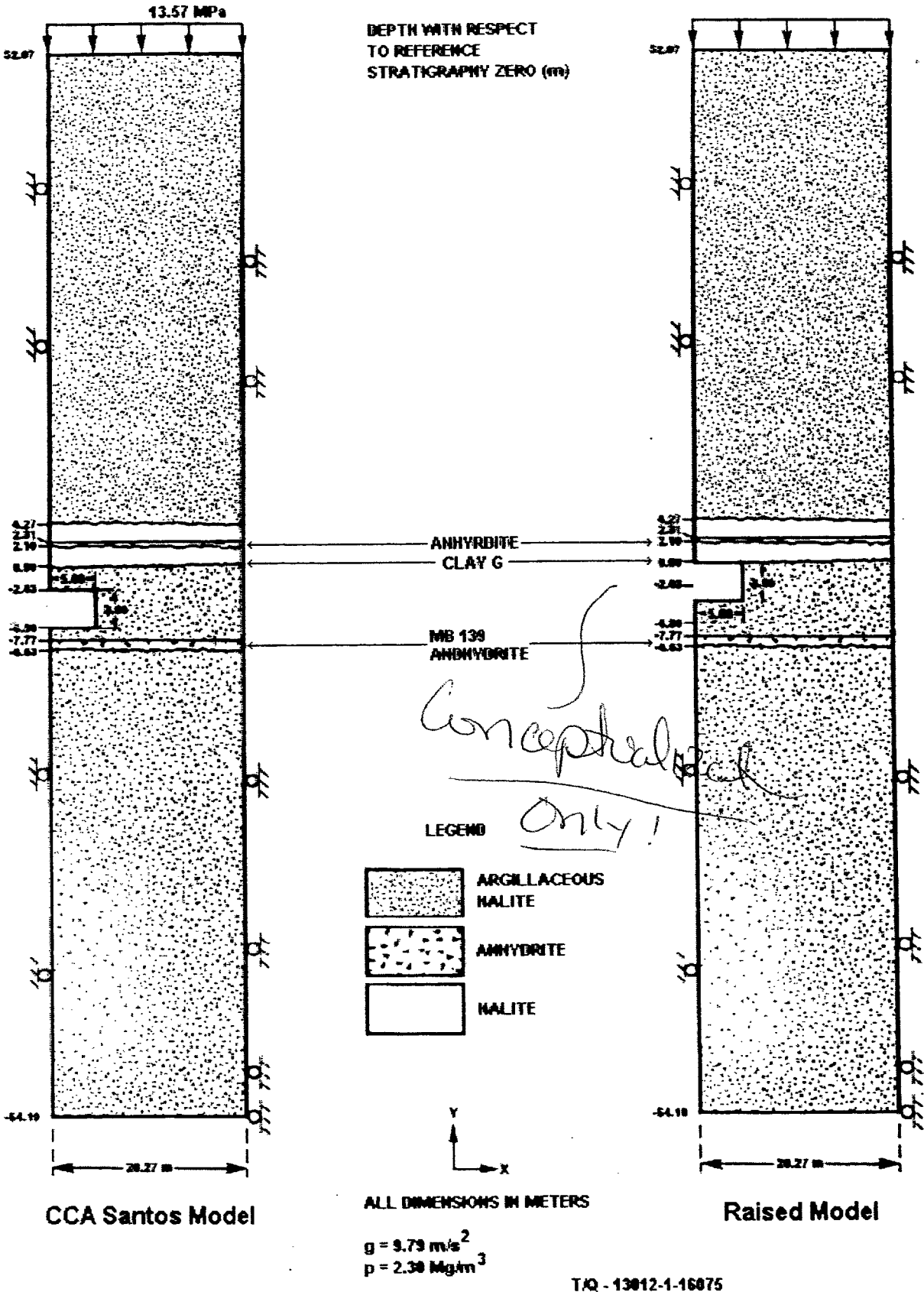
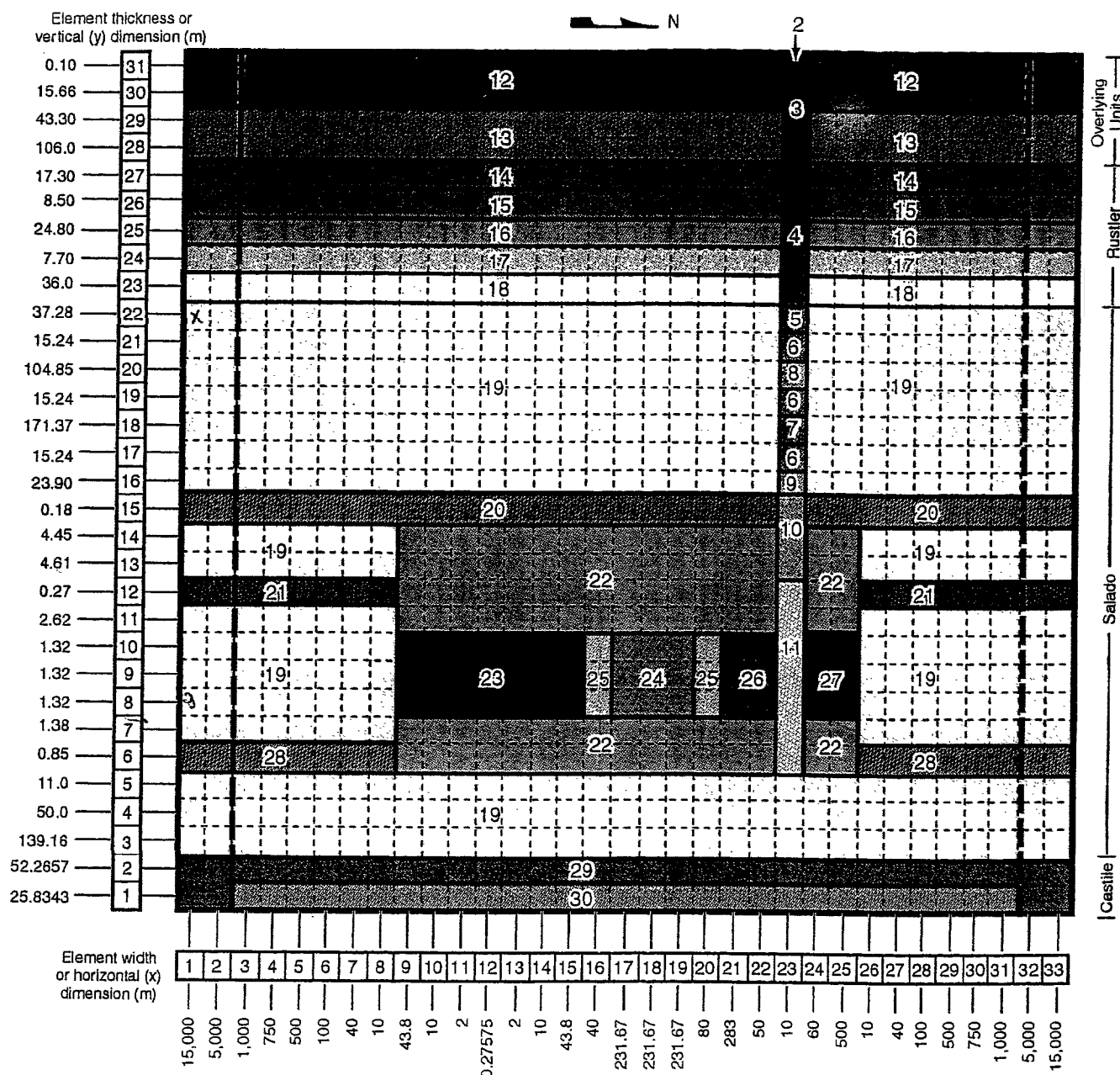

Figure 4. Simplified Stratigraphic Model Used For the Current Disposal Room Analyses (Butcher, 1997).

Title 40 CFR Part 191 Compliance Certification Application



- | | | |
|---|---------------------------------------|-----------------------------|
| 2. Shaft | 8. Upper Salado compacted clay column | 20. MB138 |
| 3. Earth fill | 9. Lower Salado compacted clay column | 21. Anhydrite layer a and b |
| 4. Rustler compacted clay column | 10. Lower clay component | 22. Disturbed rock zone |
| 5. Asphalt | 11. Concrete monolith | 23. Waste panel |
| 6. Concrete | 12. Units above the Dewey Lake | 24. Rest of repository |
| 7. Crushed salt (compacted salt column) | 13. Dewey Lake | 25. Panel closures |
| | 14. Forty-niner | 26. Operation region |
| | 15. Magenta | 27. Experimental area |
| | 16. Tamarisk | 28. MB139 |
| | 17. Culebra | 29. Castile |
| | 18. Unnamed lower member | 30. Brine reservoir |
| | 19. Impure halite | |

Boundary of accessible environment

CCA-017-2

Figure 6-13. A Side View of the BRAGFLO Elements and Material Regions Used for Simulation of Undisturbed Performance

Title 40 CFR Part 191 Compliance Certification Application

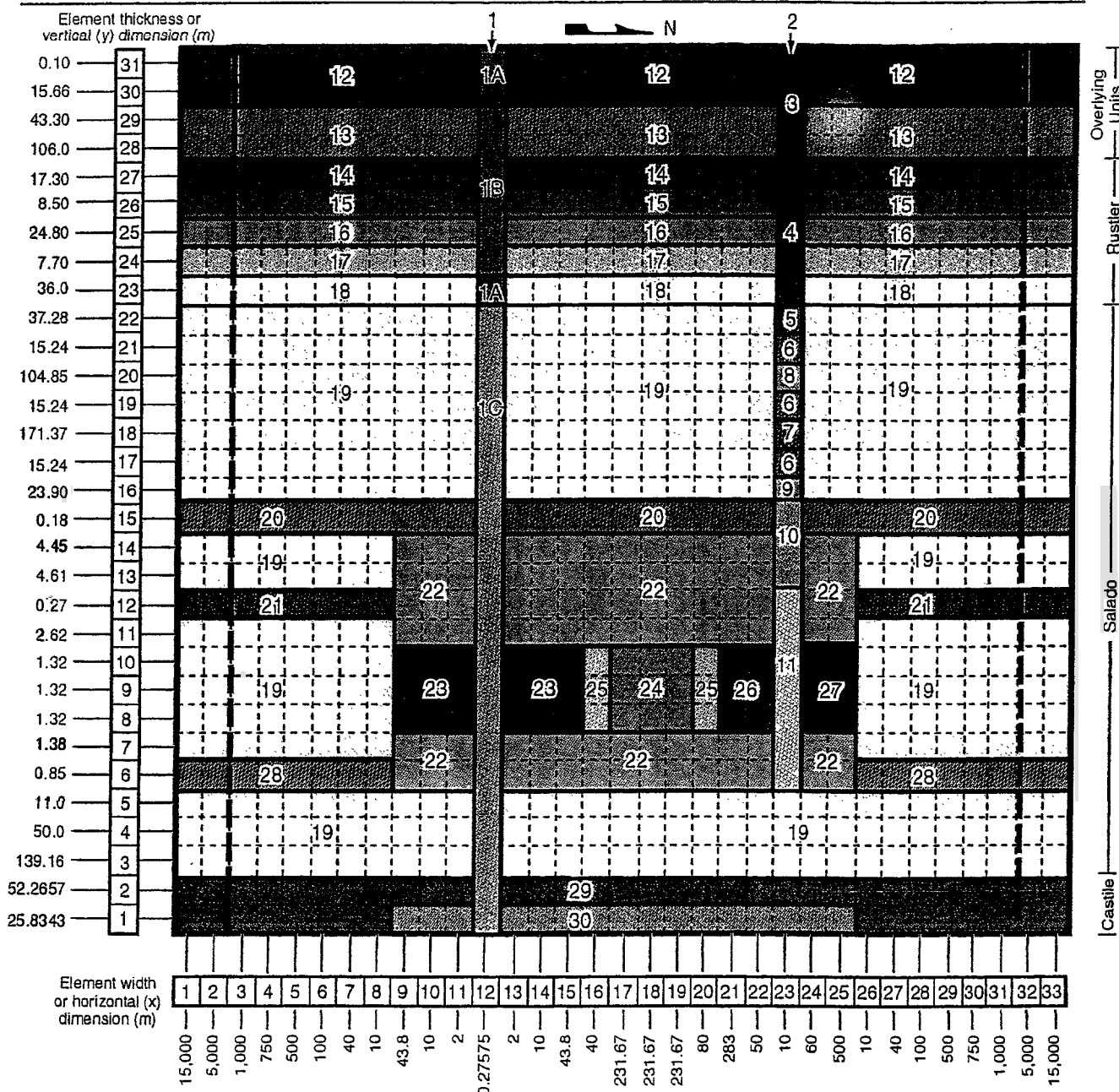

- | | | |
|---|---------------------------------------|-----------------------------|
| 1. Borehole (first 200 years) | 8. Upper Salado compacted clay column | 20. MB138 |
| 1A. Borehole concrete plug | 9. Lower Salado compacted clay column | 21. Anhydrite layer a and b |
| 1B. Upper unrestricted borehole | 10. Lower clay component | 22. Disturbed rock zone |
| 1C. Lower unrestricted borehole | 11. Concrete monolith | 23. Waste panel |
| 2. Shaft | 12. Units above the Dewey Lake | 24. Rest of repository |
| 3. Earth fill | 13. Dewey Lake | 25. Panel closures |
| 4. Rustler compacted clay column | 14. Forty-niner | 26. Operation region |
| 5. Asphalt | 15. Magenta | 27. Experimental area |
| 6. Concrete | 16. Tamarisk | 28. MB139 |
| 7. Crushed salt (compacted salt column) | 17. Culebra | 29. Castile |
| Boundary of accessible environment | 18. Unnamed lower Member | 30. Brine reservoir |
| | 19. Impure halite | |

CCA-018-2

Figure 6-14. A Side View of the BRAGFLO Elements and Material Regions Used to Simulate the E1 Event (For E2 Event, the Borehole Extends Only Between the Surface and the Base of the Repository)

Attachment 3

Investigation of the Advantages of Removing Highly Fractured Roof Beams

DOE-WIPP 94-025

Enclosure D

DOE-WIPP 94-025

APR 23 1996

PROPERTY OF WIPP LIBRARY

Investigation of the Advantages of Removing Highly Fractured Roof Beams

August 1994

Waste Isolation Pilot Plant

Highly Fractured

This document is issued by Westinghouse Electric Corporation, Waste Isolation Division, as the Management and Operating Contractor for the Department of Energy, Waste Isolation Pilot Plant, Carlsbad, New Mexico, 88221.

DOE CONTRACT NUMBER: DE-AC04-86AL31950

DISCLAIMER

This document was prepared as an account of work sponsored by an agency of the United States Government. Neither the United States Government nor any agency thereof, nor any of their employees, makes any warranty, express or implied, or assumes any legal liability or responsibility for the accuracy, completeness, or usefulness of any information, apparatus, product or process disclosed, or represents that its use would not infringe privately owned rights. References herein to any specific commercial product, process, or service by trade name, trademark, manufacturer, or otherwise, does not necessarily constitute or imply its endorsement, recommendation, or favoring by the United States Government or any agency thereof. The views and opinions of authors expressed herein do not necessarily state or reflect those of the United States Government or any agency thereof.

This document has been reproduced directly from the best possible copy. It is available to DOE and DOE contractors at the following address:

Office of Scientific and Technical Information
P. O. Box 62
Oak Ridge, TN 37831

Prices available from (615) 576-8401

Author C. Franck e

**Available to the public from the
National Technical Information Service
U. S. Department of Commerce
5285 Port Royal Road
Springfield, VA 22161**

TABLE OF CONTENTS

1.0 INTRODUCTION	1
2.0 CONCEPTUAL MODEL FOR EXCAVATION STABILITY AT WIPP	2
3.0 FIELD OBSERVATIONS	4
3.1 ROOF BEAM REMOVED IN EXISTING DRIFT - SALT HANDLING SHAFT STATION	4
3.1.1 <i>Fracturing in the Salt Handling Shaft Station</i>	4
3.1.2 <i>Geomechanical Instrumentation in the Salt Handling Shaft Station</i>	5
3.2 DRIFT ORIGINALLY MINED WITHOUT ROOF BEAM	6
3.2.1 <i>N1100 and N1420 Drifts Comparison</i>	6
3.2.1.1 <i>Fracturing in the N1100 and N1420 Drifts</i>	7
3.2.1.2 <i>Geomechanical Instrumentation in the N1100 and N1420 Drifts</i>	7
3.2.2 <i>Rooms D, B, and A</i>	7
3.2.2.1 <i>Fracturing in Rooms D, B, and A</i>	8
3.2.2.2 <i>Geomechanical Instrumentation in Room D</i>	8
3.3 SUMMARY OF FIELD OBSERVATIONS	8
4.0 NUMERICAL ANALYSES	10
4.1 SALT SHAFT STATION ROOF BEAM REMOVAL	10
4.2 N1420 ROOF BEAM REMOVAL	11
4.3 E140 ROOF BEAM REMOVAL	11
4.4 SOUTH E140 DRIFT ENLARGEMENT.....	12
4.5 ROOM D AND N1100 DRIFT MODELS.....	13
4.6 SUMMARY OF NUMERICAL ANALYSES	13
5.0 SUMMARY OF RESULTS	14
5.1 CONCLUSIONS.....	14
5.2 RECOMMENDATIONS	15
6.0 REFERENCES	16

LIST OF FIGURES

- 1 Typical Convergence Rate Curve Leading to Failure**
- 2 Advanced Fracture Formation in Roof**
- 3 Stress Concentration Comparison for Two Different Roof Beam Geometries**
- 4 Waste Isolation Pilot Plant Mine Layout**
- 5 Salt Handling Shaft Station Profile Before Roof Beam Removed**
- 6 Salt Handling Shaft Station Profile After Roof Beam Removal**
- 7 Salt Shaft Station Fracturing Comparison - 24 Feet South of Shaft**
- 8 Salt Shaft Station Fracturing Comparison - 56 Feet South of Shaft**
- 9 Salt Handling Shaft Station E0/S65 Roof Extensometer**
- 10 Salt Handling Shaft Station E0/S30 Roof Extensometer**
- 11 Salt Handling Shaft Station E0/S65 Vertical Convergence**
- 12 Stratigraphic Location of N1100 and N1420 Drifts**
- 13 Fracture Data - N1420/E1375**
- 14 Fracture Data - N1100/E1303**
- 15 N1100 and N1420 Drifts Comparison - Vertical Convergence**
- 16 N1100 and N1420 Drifts Comparison - Horizontal Convergence**
- 17 Stratigraphic Location of Rooms A, B, and D**
- 18 Model Results for Salt Shaft Station Before Roof Beam Removal**
- 19 Model Results for Salt Shaft Station After Roof Beam Removal**
- 20 Model Results for N1420 Drift Before Roof Beam Removal**
- 21 Model Results for N1420 Drift Without Roof Beam Removal**
- 22 Model Results for N1420 Drift With Roof Beam Removed**
- 23 Model Results for E140 Drift Before Roof Beam Removal**
- 24 Model Results for E140 Drift Without Roof Beam Removal**
- 25 Model Results for E140 Drift With Roof Beam Removed**
- 26 Stratigraphic Location of E140 Drift South of S2180**

LIST OF FIGURES (continued)

27 Model Results for South E140 Drift With Floor Lowered

28 Model Results for South E140 Drift With Roof Beam Removed

29 Model Results for N1100 Drift

30 Model Results for Room D

INVESTIGATION OF THE ADVANTAGES OF REMOVING HIGHLY FRACTURED ROOF BEAMS

1.0 Introduction

The behavior of the underground excavations at the Waste Isolation Pilot Plant has been intensely studied for over ten years. All excavations have performed their intended functions safely with normal maintenance and ground support. The deformation characteristics and mechanisms are well understood. Many openings such as the main access drifts and shaft stations must remain open for the life of the facility. With many openings now ten years old or older and a twenty-five year operational (disposal) phase planned for 1998, these drifts are required to be usable for over forty years. It has been proposed that mining out the roof of the excavations up to the nearest clay seam may extend the useful life of some excavations. This report reviews available rock mechanics information relevant to improving drift stability by removing the roof beam. For the purposes of this document, a "roof beam" is defined as the section of rock between the roof of the excavation and the nearest clay seam above the roof. A drift with a clay seam forming the roof is defined as having no roof beam. Theoretical deformation mechanisms believed to be at work at WIPP are briefly discussed. Field data from excavations with a clay seam forming the roof are reviewed. Finally, numerical modeling results compare the performance of excavations with and without roof beams. Only the geomechanical effects of the roof beam are discussed in detail here. Economics are only considered in passing. The removal of a roof beam in an existing drift would have several non-geomechanical consequences. The ventilation balance would change with the drift cross-section. Utilities would also need to be removed and reinstalled.

2.0 Conceptual Model for Excavation Stability at WIPP

The stability of excavations at WIPP is assessed by analysis of creep displacement and fracture formation. Fracturing and increasing displacement are closely related and in the absence of increased stress levels or increased temperature, displacement rate increases can only be caused by forming and opening fractures.

The general scenario for unsupported WIPP excavations is: 1) excavation is mined and displacement rates begin decreasing (Figure 1, Curve A). Localized (one to ten feet long) shallow spalls associated with poor rock conditions are frequently observed soon after excavation; 2) excavation deforms smoothly according to creep properties of salt (Curve B). Low angle shear fractures form near the ribs and separations and horizontal offsets form at clay seams; 3) large scale fracturing that goes deep into the rock develops and closure rates increase (Curve C). Given sufficient time, the roof of an unsupported excavation will probably continue to fracture until the roof falls (Point D). The formation of the large scale fractures in the roof is influenced by several factors. A conceptual model for the fracturing is summarized below.

Zones of high shear stress develop in the roof near the ribs immediately after excavation. These zones are weakened relative to the rest of the roof beam. At the same time, the pillars expand horizontally into the excavation. Clay seams located in the roof (usually either Clay G or Clay I) or floor (usually clay E) slip under the horizontal displacement of the pillar (Figure 2). This effectively concentrates the pillar expansion between the clay seam in the roof and the clay seam in the floor. The high horizontal load is partly relieved by roof sag and partly by the formation of fractures. The weak zones in the roof formed by the

early high shear stress are the most probable locations for fracture formation under the high horizontal stress from the pillars. These fractures are usually diagonal originating near each rib and terminating near the clay seam. Once the fractures are large and extensive enough, gravity forces due to the dead weight of the slab become dominant. As the fractures become more extensive, the ability of the slab to support its own weight is reduced, which in turn causes more fracturing. This is why displacement rates increase exponentially as extensive fracturing develops.

Since this scenario is generally accepted, it has been suggested that an excavation with a clay seam forming the roof would be more stable. The thought is that the clay seam at the roof would slip as the pillar expanded, thus reducing to a minimum the transmission of load to the roof and therefore the fracturing in the roof (Figure 3). According to the conceptual model, an excavation with clay seams forming both the roof and floor would be even better. Field data and numerical analyses will be used to evaluate both the scenario and the suggestion in order to determine what geotechnical benefits might be obtained.

3.0 Field Observations

Field observations, in the form of displacement measurements and fracture mapping, support the concept of removing the roof beam to enhance stability. Because many of the drifts that require long lives have already been mined, the effect of removing the roof beam well after initial mining must be investigated as well as mining the roof at Clay G from the beginning. Figure 4 is the WIPP underground layout with locations discussed in this and the following sections highlighted.

3.1 Roof Beam Removed in Existing Drift - Salt Handling Shaft Station

The only excavation at WIPP that has had the roof beam removed up to a clay seam well after initial mining is the Salt Handling Shaft Station. The station was mined (by drill and blast) in 1982 with a 14 to 18 foot high roof (Figure 5). The roof up to Clay G began deteriorating soon after excavation, at least partially because of poor charge control during mining. By 1987, the roof had deteriorated to the point that it was decided to remove the roof beam. The roof beam was removed (Figure 6) between November 1987 and February 1988 using a Tamrock scaler. Because this is a one of a kind excavation for WIPP (in terms of size, shape, and mining method), strong conclusions cannot be drawn from it. However, it must be examined here because its roof beam has been removed.

3.1.1 Fracturing in the Salt Handling Shaft Station

Since the roof beam was removed in the Salt Station, large scale fracturing has not redeveloped. Figures 7 and 8 show fracturing in the roof in May 1987 before roof beam removal and six years after the roof was removed. There are far

fewer fractures with much smaller openings even six years after the roof was removed than there were before the roof was removed. Removing the roof beam has improved the condition (in terms of fracturing) of the Salt Shaft Station roof.

3.1.2 Geomechanical Instrumentation in the Salt Handling Shaft Station

Geomechanical instrumentation in the Salt Station also indicate that the roof is much more stable since the roof beam was removed. Figure 9 shows the roof displacement rate in the station 65 feet south of the shaft. This extensometer is located in the thickest part of the station roof where the roof was about seven feet below Clay G. Displacement rates after the roof was removed are about 25 percent of the earlier rates. This indicates that the new roof is considerably more stable since the old roof was removed. Figure 10 shows the roof displacement rate in the station 30 feet south of the shaft. The old roof beam here was only three to four feet thick. The reduction in displacement rate after the beam was removed is not as obvious for the thin roof beam. Recalling that the roof was both highly fractured and extensively rockbolted, this is probably due to the ground support and the weight of the beam. Once the roof became highly fractured, the thinner beam would be subject to less dead weight load. The smaller dead weight load would be more easily supported by the rockbolts. The lighter slab would also be less likely to form additional fractures due to its own weight. The thicker slab would be heavy enough to continue fracturing and would be harder to support with the rockbolts. Once the fractured roof was removed, excessive displacement due to fracturing no longer occurred. Thus the reduction in displacement and closure rates.

Roof to floor convergence measurements at S65 show similar results (Figure 11). After roof beam removal, convergence rates dropped to about 33 percent of the earlier rates. Again, the convergence points under the thinner section of the roof did not show such dramatic drops. Horizontal convergence rates remained about the same for all stations before and after roof beam removal.

3.2 Drift Originally Mined Without Roof Beam

Several drifts have been mined with Clay H or Clay I as the roof. These include the eastern N1100 drift with roof and floor formed by clays H and G, respectively, and the A, B, and D Rooms which have Clay I and G within a foot below and above the roof and floor, respectively. The performance of each of these drifts will be examined to determine the effect of their stratigraphic location.

3.2.1 N1100 and N1420 Drifts Comparison

These drifts are both 14 feet wide and were mined in 1984. N1420 is 12 feet high and N1100 is eight feet high. However, the configuration of the roof and floor beams are different in each drift. N1420 and N1100 at the experimental level have Clay G forming the floor. Clay H forms the roof in N1100 while N1420 has a five foot roof beam bounded by Clay I. Figure 12 shows the relative stratigraphic location of the drifts. The effect of a clay seam forming the roof can be examined by comparing the performance of the two drifts.

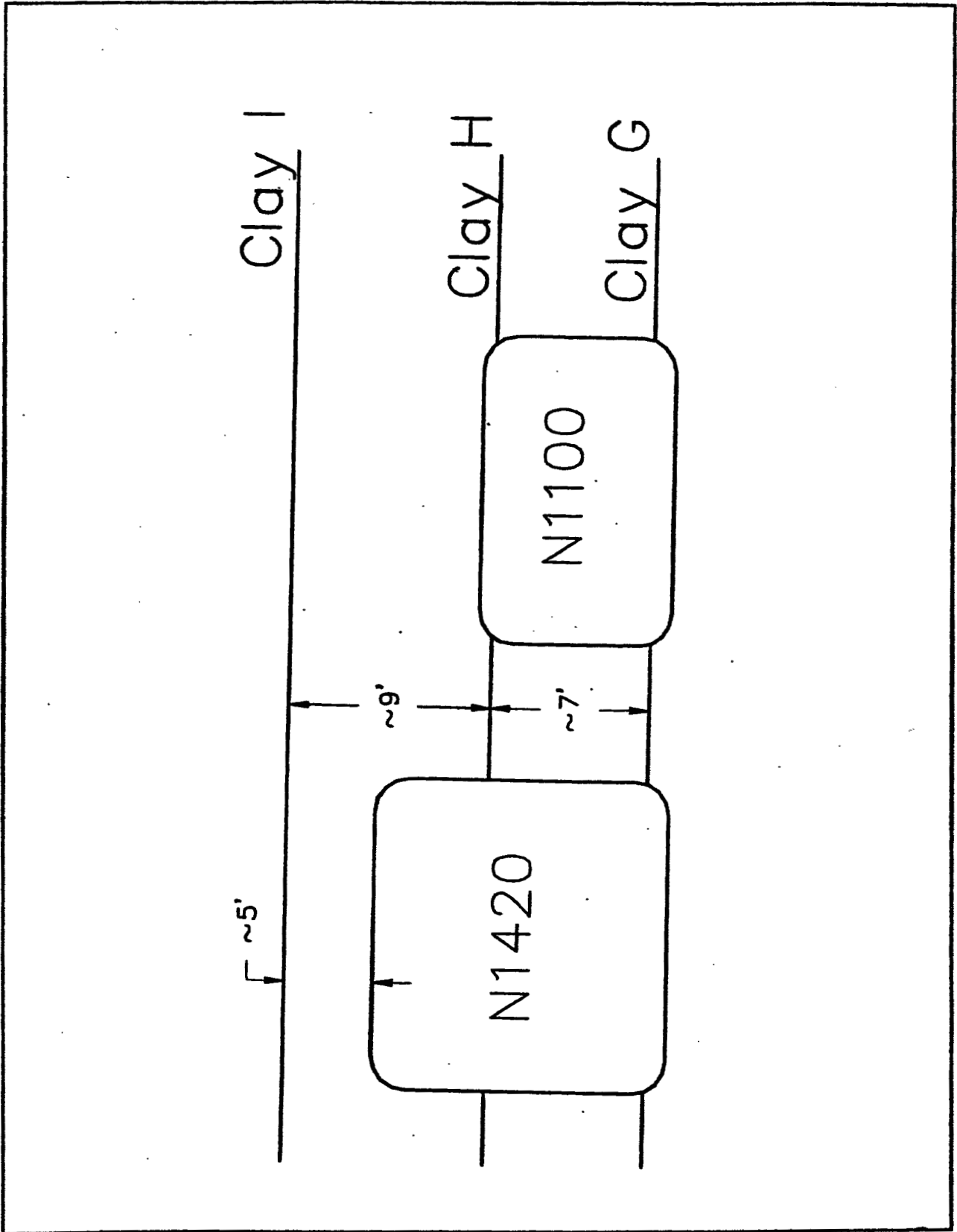

Figure 12
Stratigraphic Location of N1100 and N1420 Drifts

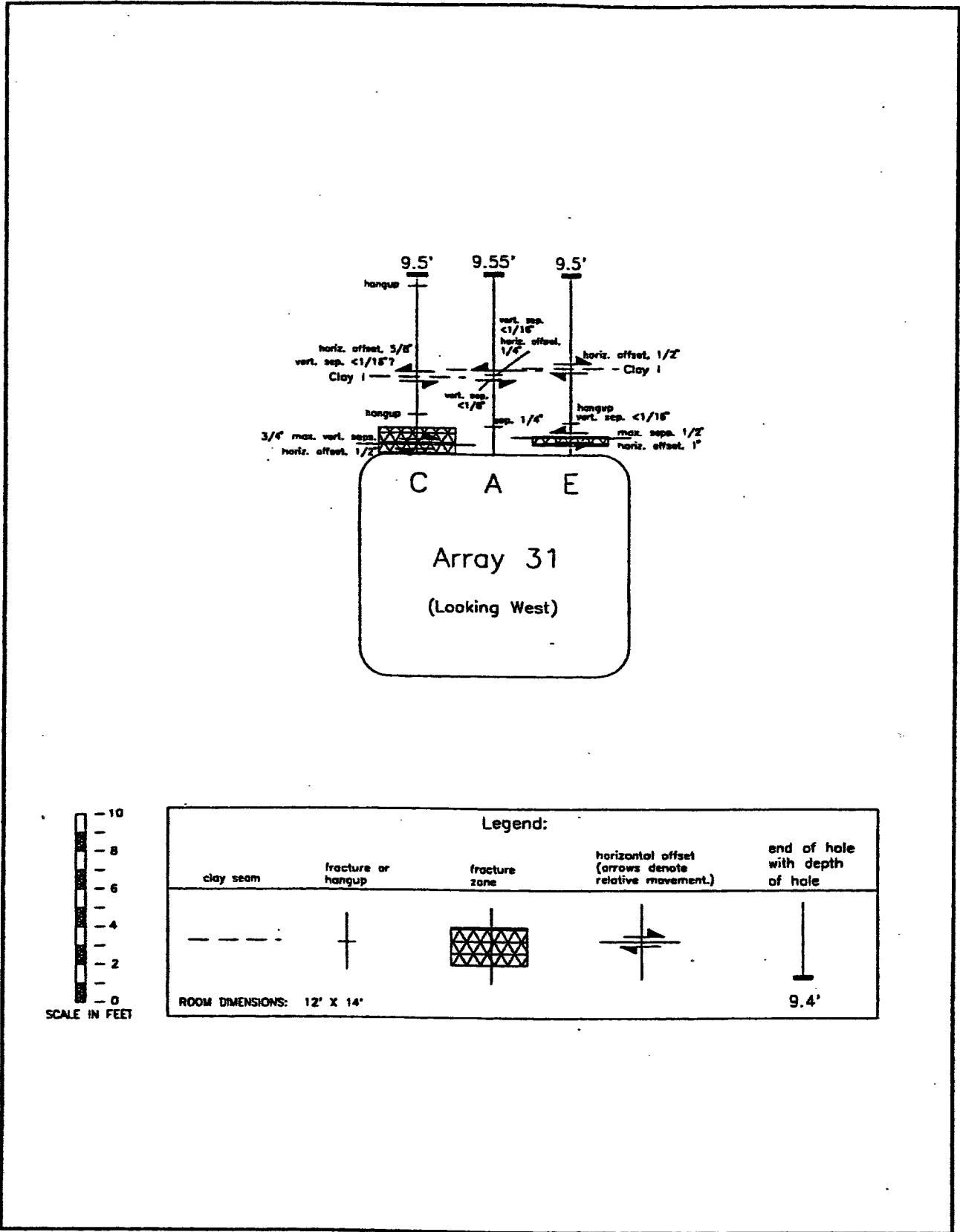

Figure 13
Fracture Data - N1420/E1375

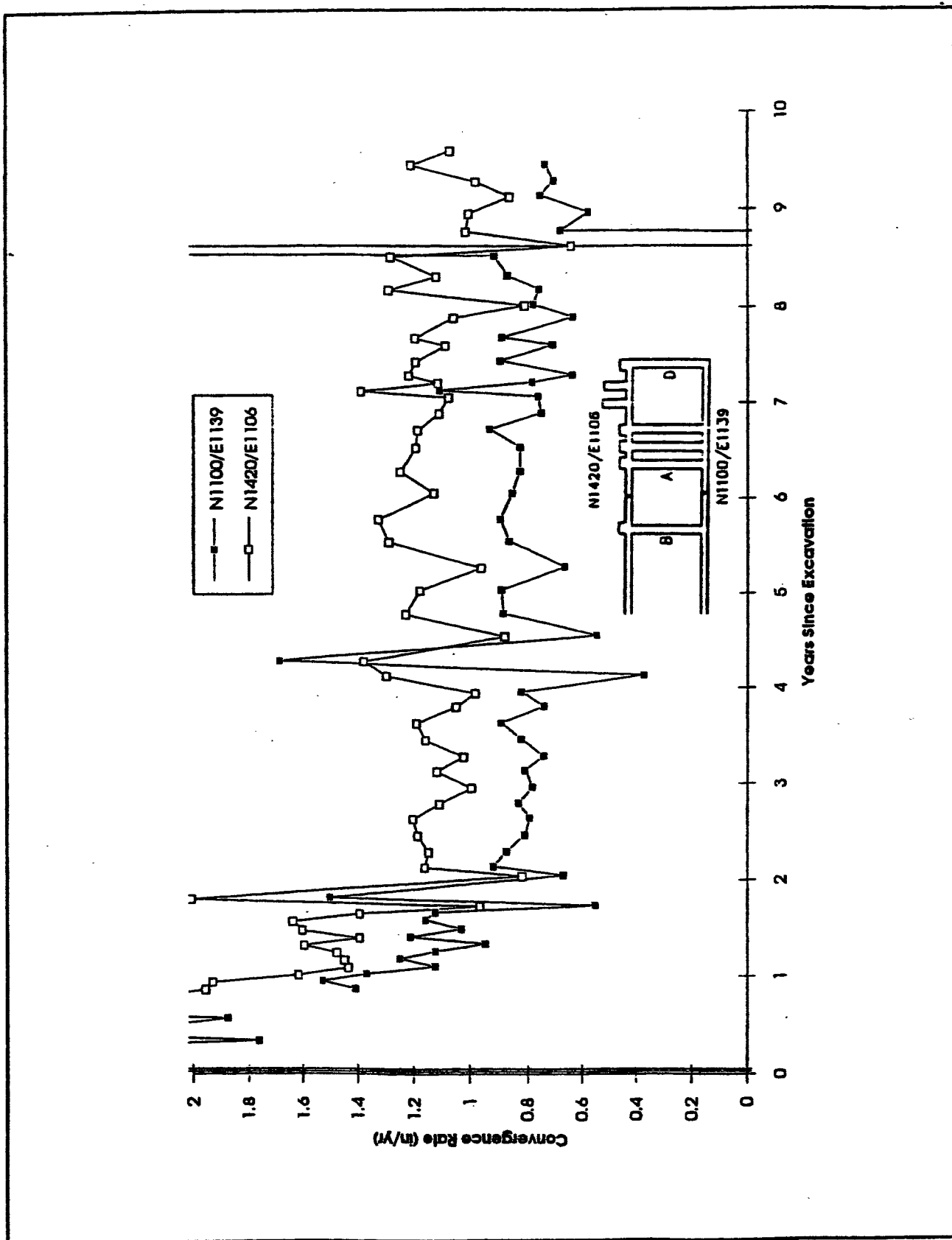

Figure 15
N1100 and N1420 Drifts Comparison Vertical Convergence

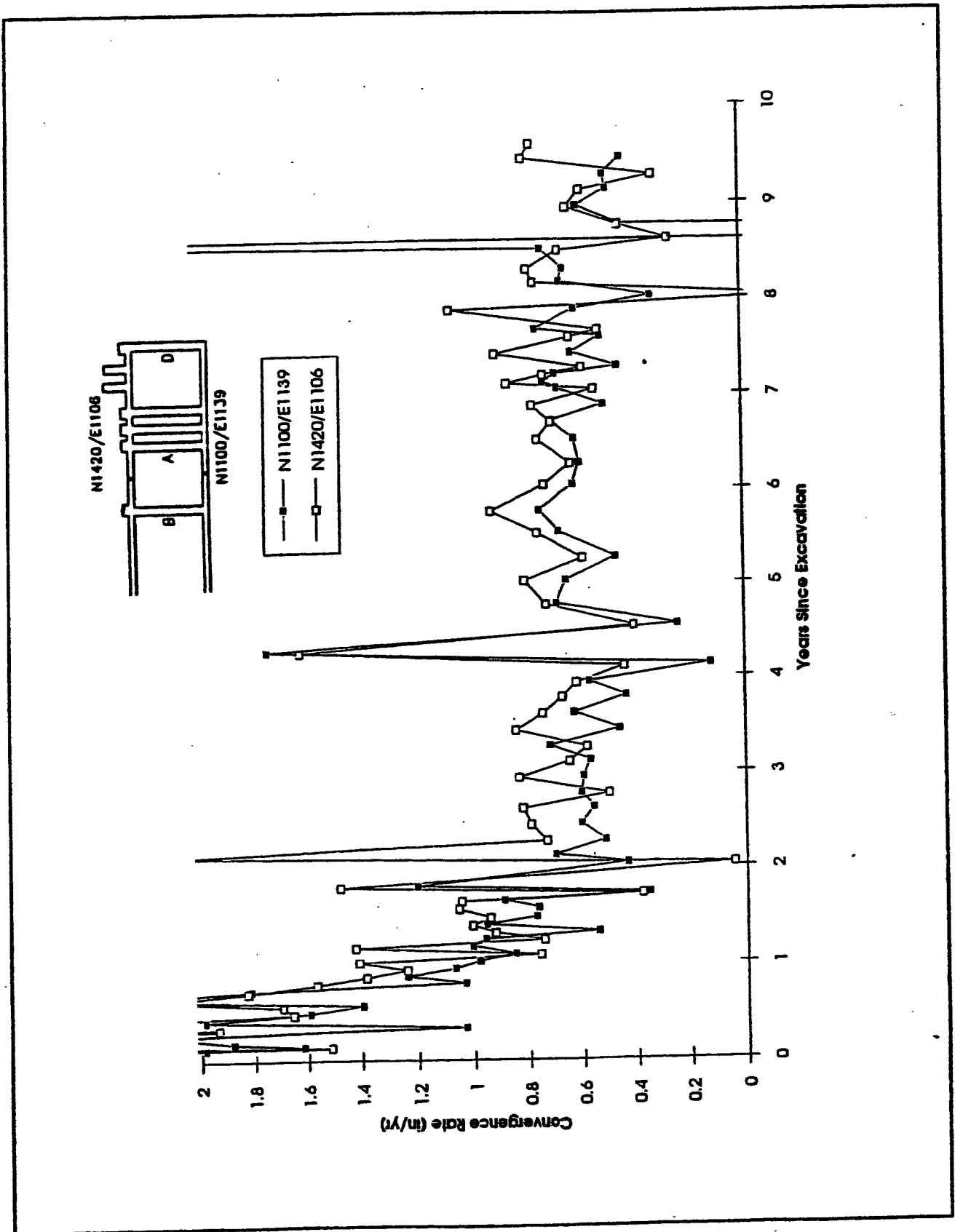

Figure 16
N1100 and N1420 Drifts Comparison Horizontal Convergence

3.2.1.1 Fracturing in the N1100 and N1420 Drifts

Roof fracturing is relatively intense in the N1420 drift, which has a five foot thick roof beam and no floor beam. Large scale diagonal fractures have developed along with vertical cracks in the roof (Figure 13). The N1100 drift, which has no roof or floor beam, has very little fracturing (Figure 14). It is clear from the fracture observations that of these two drifts of nearly the same age and size, the N1100 drift, with no roof beam, is in much better condition than the N1420 drift with a roof beam and no floor beam.

3.2.1.2 Geomechanical Instrumentation in the N1100 and N1420 Drifts

The only instrumentation in the N1100 and N1420 drifts are vertical and horizontal convergence gauges. Vertical convergence rates in the N1420 drift between Room B and Room A2 are about 150% of the rates in N1100 (Figure 15) at the same relative location. The difference is probably due to bending and breakup of the roof beam in N1420. Horizontal rates are only slightly higher in the N1420 drift, indicating that the location of the clay seams at the roof and floor lines in N1100 does not cause high horizontal convergence rates (Figure 16).

3.2.2 Rooms D, B, and A

Rooms D, B, and the A's are 18 feet high by 18 feet wide and were all mined in 1984. The roof of these rooms is formed by Clay I and the floor by Clay G (Figure 17). Heaters in Room B and the A Rooms raised the air temperature about 50° F for about three years. Because salt creep is very sensitive to temperature, the discussion will focus on Room D which was not heated.

3.2.2.1 Fracturing in Rooms D, B, and A

Room D has six-foot rockbolts installed on a wide (6'-8' x ~10') pattern. Shallow fractures less than two feet deep were first observed in the roof soon after excavation. The slabs formed by these fractures do not appear to go much deeper into the roof and would be easily supported with standard rockbolts. Room B was rockbolted after long, thick slabs formed in the roof. There has not been a roof fall in Room B. There have been several roof falls in the A Rooms, which were not rockbolted. The fallen slabs were about 18 inches thick. The falls were allowed to occur because of the experimental use of the rooms. The rooms had been barricaded and normal maintenance was not performed. Considering that the high temperatures significantly accelerated deformations in the A rooms and Room B, all the 18'X18' drifts have performed very well.

3.2.2.2 Geomechanical Instrumentation in Room D

Both vertical and horizontal convergence in Room D have been very low considering the size of the room. Vertical convergence is about 1.1 inches per year versus a predicted rate of 1.7 inches per year. Horizontal convergence is about 0.8 inches per year versus a predicted rate of about 1.3 inches per year. Predicted values are from an empirical analyses of convergence at WIPP (USDOE, 1993). The low convergence rates may be attributed to the good condition of the roof, floor, and walls which in turn may be attributed to the presence of the clay seams forming the roof and floor.

3.3 Summary of Field Observations

Field observations in the form of geomechanical instrumentation and fracture mapping have been examined in all rooms without clay seams forming the roof

or floor and in the only room that has had the roof removed to a clay seam. In all cases, the drifts with a clay seam forming the roof performed much better than their counterparts with a roof beam. Without exception, the field data demonstrate that initially mining drifts with a clay seam forming the roof makes for long-lasting, stable excavations. The field data also demonstrates that removing a roof beam well after excavation improves the stability of a drift.

It should be noted here that given a drift with a closure rate of two inches per year, after 40 years the drift will have lost 80 inches of its initial height. An originally 13 foot high excavation would be about six feet high after 40 years. Obviously the excess convergence cannot be completely mitigated by trimming the floor. Eventually at least part of the roof beam would have to be removed. However, the thinner roof beam would be expected to fracture even more than the original beam. Therefore, removal of the roof beam may be necessary just to maintain operating clearance in the access drifts.

4.0 Numerical Analyses

Numerical analyses, in the form of finite difference modeling, can be used to investigate the effect of roof beam removal and the advantages of mining drifts without roof beams. The finite difference code used was Fast Lagrangian Analysis of Continua (FLAC) (Itasca Consulting Group, 1993). Models of the Salt Handling Shaft Station and the N1420 and E140 drifts were developed to investigate the effect of removing the roof beam well after excavation. Models of Room D and N1100 drifts were developed to investigate the effect of initially mining drifts without roof beams and for comparison to the other drifts. Although the models cannot simulate fracturing, the potential for fracturing can be related to zones of high strain concentration in the models. Therefore, the discussion will concentrate on examination of shear strain results in the models.

4.1 Salt Shaft Station Roof Beam Removal

About 5.33 years after initial excavation, between three and eight feet of salt were removed from the roof of the Salt Handling Shaft Station to bring the roof up to Clay G. Figures 18 and 19 show accumulated strain calculated by the FLAC Salt Station model. Figure 18 shows the condition at 5.33 years after excavation immediately before the roof beam was removed. The roof beam has deformed considerably with a large separation at Clay G. Figure 19 shows the condition at ten years after excavation, about five years after the roof beam was removed. Note that there is very little roof sag. Accumulated strain in the roof is just reaching levels found in the original roof beam five years earlier. The model results indicate that removing the roof beam in the Salt Shaft Station provided a more stable roof with much less deformation.

4.2 N1420 Roof Beam Removal

The FLAC model of the N1420 drift was run in two configurations. One model with the five foot thick roof beam removed after ten years and one with the roof beam left in place. Figure 20 shows deformation ten years after excavation and immediately before the roof beam is removed in the model. Figure 21 shows conditions at twenty years after excavation with the roof beam left in place. Figure 22 shows conditions at twenty years after excavation with the roof beam removed ten years earlier. At ten years, the roof beam in the model has undergone high strains. If the roof beam is left in place, as in Figure 21, the strains only continue to build. However, with the roof beam removed at ten years, the highly strained material is removed and the new roof does not build up new high strains, even after twenty years. The model results indicate that removing the roof to Clay G in the N1420 drift will provide a much more stable roof, and fracturing will not be a problem for at least ten years and possibly longer.

4.3 E140 Roof Beam Removal

The FLAC E140 Drift model was also run in two configurations. One model has the six foot thick roof beam removed after ten years and one leaves the roof beam in place to twenty years. Figure 23 shows deformation after ten years immediately before the roof beam is removed in the model. Figure 24 shows conditions at twenty years with the roof beam left in place. Figure 25 shows conditions at twenty years with the roof beam removed ten years earlier. The results are very similar to the N1420 drift models. With the beam removed, strain is less in the roof after twenty years than it was in the roof beam before

removal at ten years. Because Clay H is fairly close to the new roof in E140, there is more concentration of strain in the new roof of the E140 drift than in the new roof of the N1420, which does not have a nearby clay seam. Again, the removal of the roof beam in the model leaves a more stable and presumably longer lived excavation.

4.4 South E140 Drift Enlargement

The E140 Drift south of S2180 was mined in early 1983 with dimensions of about 8' to 9.5' high by 25' wide. The drift is not rockbolted and has been barricaded since 1989. No geomechanical measurements or visual observations have been made in the drift since it was barricaded. Figure 26 shows the stratigraphic location of the drift as it is currently configured. To accommodate excavation of Panel 2, the E140 Drift south of S2180 will need to be enlarged to allow large equipment to pass.

Two ways of enlarging the E140 drift have been modeled. One model lowers the floor of the south E140 drift eleven years after initial excavation. The other model removes the roof beam up to Clay G after eleven years. Figures 27 and 28 show strain around the drift for each configuration after twenty years (nine years after enlarging). Strain in the roof of the drift that had the floor lowered (Figure 27) is about twice that of the drift with the roof beam removed (Figure 28). This indicates that fracturing will be much more intense in the configuration with the stratigraphically lower roof. This suggests that removing the roof beam, which gives a 16 foot tall excavation, will both ease maintenance and provide a longer useful life than lowering the floor.

4.5 Room D and N1100 Drift Models

FLAC models of Room D and of the N1100 drift in the experimental area were developed for comparison to other models. Figure 29 shows strain around the N1100 drift twenty years after excavation. Strains are low in the roof of the N1100 model, particularly compared to the N1420 with the roof beam at twenty years (Figure 21). The Room D model also shows low strains in the roof (Figure 30). Both of these models show high strain in the ribs, although field data do not indicate that excessive sloughing occurs.

4.6 Summary of Numerical Analyses

Numerical models were developed for a variety of excavation sizes both at the repository level and the experimental level of the facility. Models were developed for drifts mined without a roof beam from the beginning and for drifts with substantial roof beams removed later in the model's life. In all cases, the models indicate that drifts originally mined with a clay seam at the roof line perform very well. Excessive strains do not develop in the roof. In all cases where the roof beam was removed well after initial excavation, the drift performed better after the beam was removed. Again, fracturing is not simulated in the models, although the total shear strain may be used as an indication of the propensity of the rock to fracture. Also, these models cannot adequately address the performance of the floor of excavations because MB139 does not creep and is very strong. Neither of these factors significantly influence the results, so the numerical models clearly demonstrate that roof beam removal enhances the stability of WIPP excavations.

5.0 Summary of Results

The geomechanical advantages of removing old roof beams or mining drifts without roof beams from the beginning were examined in a variety of ways. A conceptual model for WIPP excavation performance was extended to postulate the effect of roof beam removal. Field data from drifts without roof beams and from drifts that had roof beams removed after initial excavation were examined to see if the effect was measurable. Finally, numerical models of various excavations were developed to examine the effect of roof beam removal or the lack of a roof beam.

5.1 Conclusions

The following conclusions were reached after examination of all the factors discussed above.

1. The conceptual model for WIPP excavation effects indicates that much of the fracturing and resulting instability in the roof of WIPP excavations is caused by the relative location of the clay seam above the roof of the excavation.
2. The field data indicate that fracturing and displacement are minimized in the roof of excavations without a roof beam.
3. The field data indicate the removal of a highly fractured roof beam significantly improves the stability of excavations.
4. The field data indicate that roof beam removal eventually will be necessary in order to maintain operating clearance in life of mine drifts.
5. Numerical analyses indicate that over equivalent times drifts without roof beams develop less strain in the roof than drifts with roof beams.
6. Numerical analyses indicate that the removal of a highly deformed roof beam significantly improves the condition of the roof.
7. The conceptual model, field data, and numerical analyses are reasonably consistent in their conclusions.

8. The E140 drift south of S2180 should be enlarged by removing the roof beam entirely rather than by lowering the floor and trimming the roof beam.
9. Drifts, such as Room D, that are originally mined with a clay seam forming the roof and floor will be much longer lived and require less maintenance than drifts with a roof beam.
10. The life of drifts with highly fractured roof beams can be significantly lengthened by removing the roof beam to the nearest clay seam.

5.2 Recommendations

In light of the conclusions reached by examination of the conceptual model, field data, and numerical analyses, the following recommendations are made concerning removal of roof beams.

1. New excavations requiring long useful lives should be mined with the roof at a clay seam. At the facility level, the roof should be at Clay G.
2. The roof beam should be removed from old excavations with highly fractured roofs once they require high maintenance efforts.
3. The timing of roof beam removal should be based on the level of effort required to maintain the existing roof. There is no need to remove the roof beam if maintenance is low.

6.0 References

Itasca Consulting Group, Inc., 1993, "FLAC User's Manual," Minneapolis, Minnesota.

USDOE, 1993, "Geotechnical Field Data and Analysis Report, Volume I of II, July 1991 - June 1992," Waste Isolation Pilot Plant, Carlsbad, New Mexico.

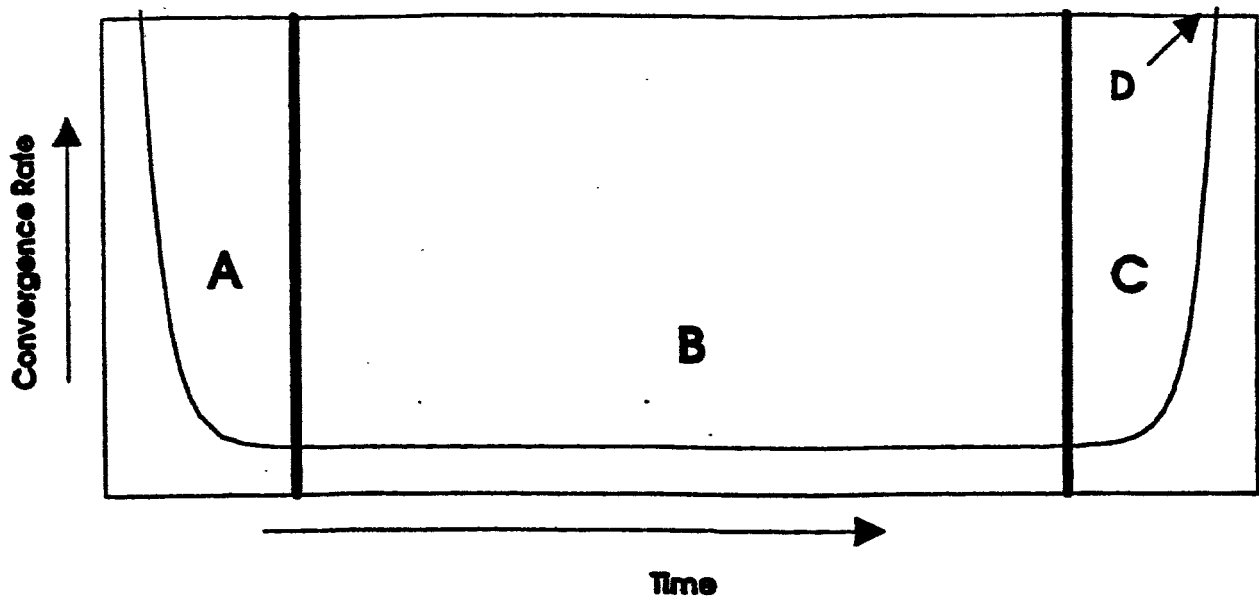

Figure 1
Typical Convergence Rate Curve Leading to Failure

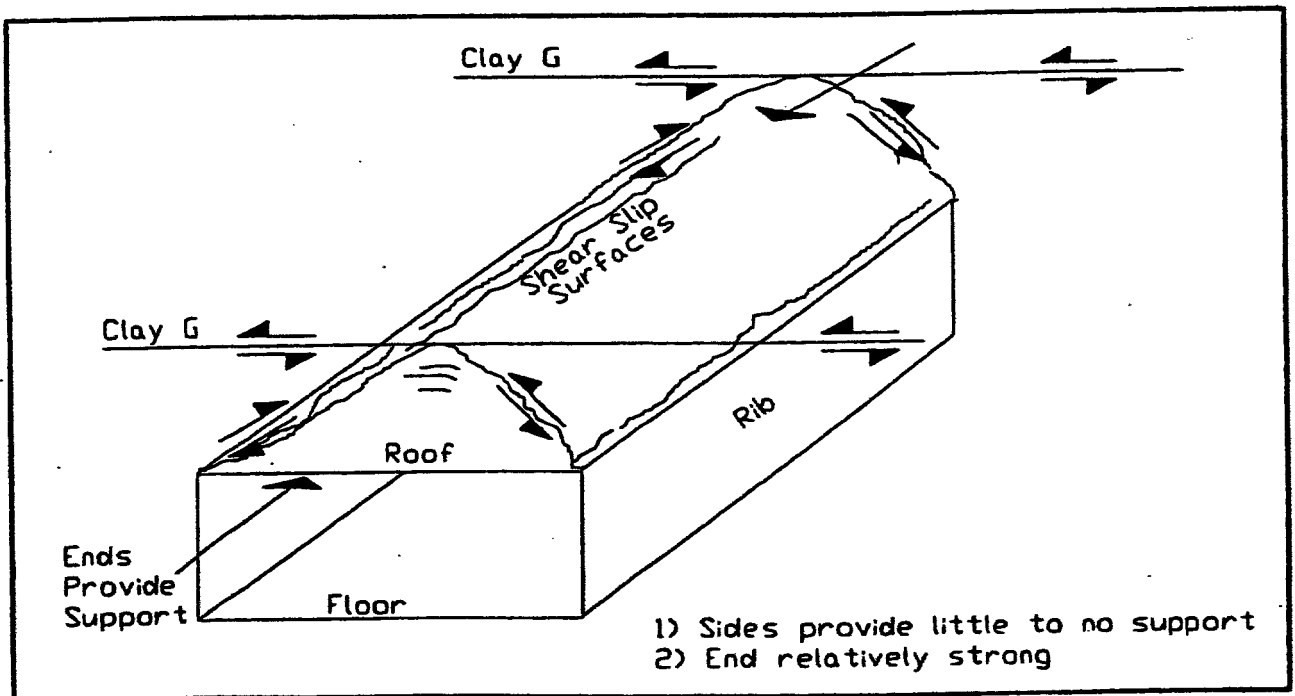

Figure 2
Advanced Fracture Formation in Roof

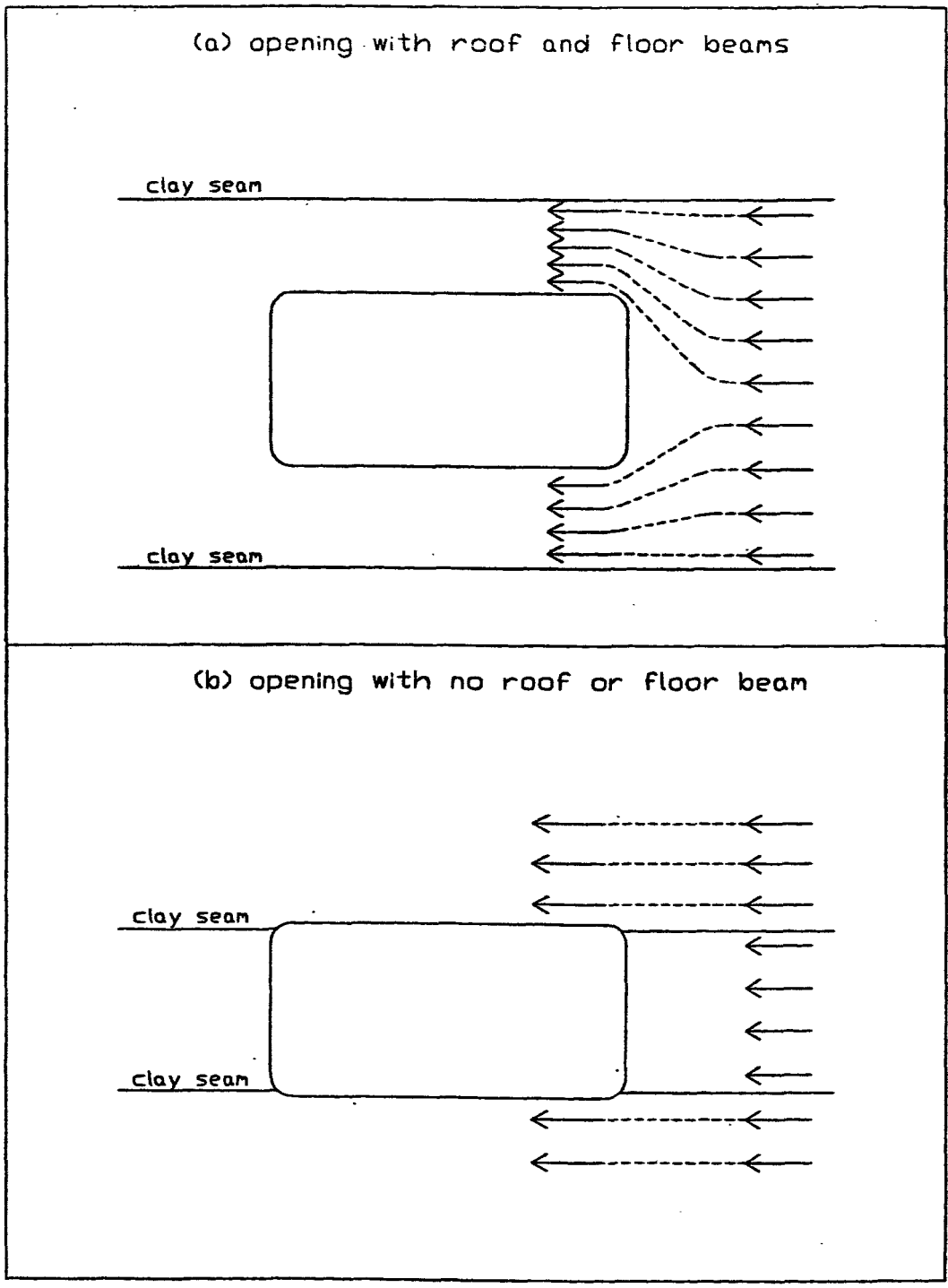

Figure 3
Stress Concentration Comparison for Two Different Roof Beam Geometries

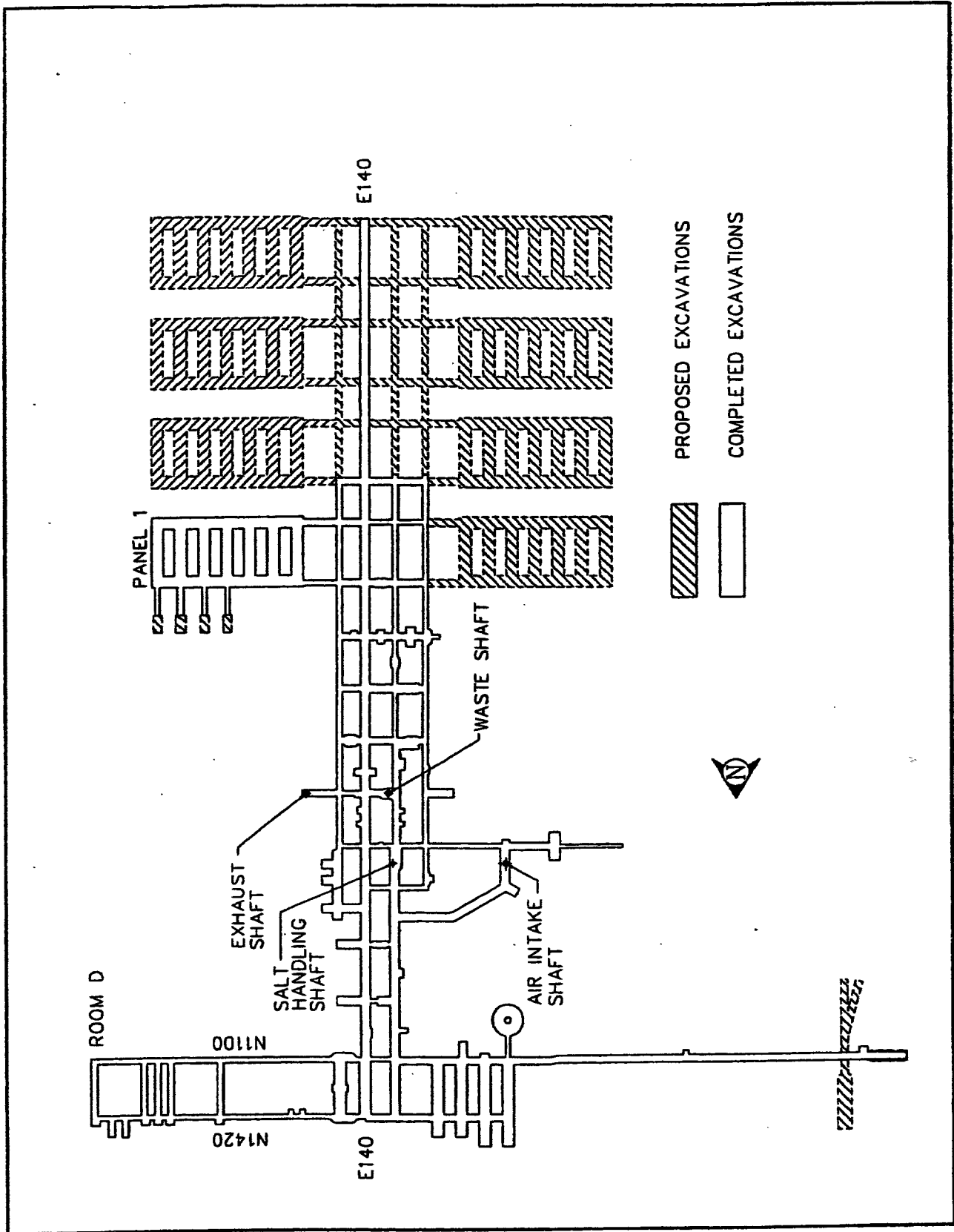

Figure 4
Waste Isolation Pilot Plant Mine Layout

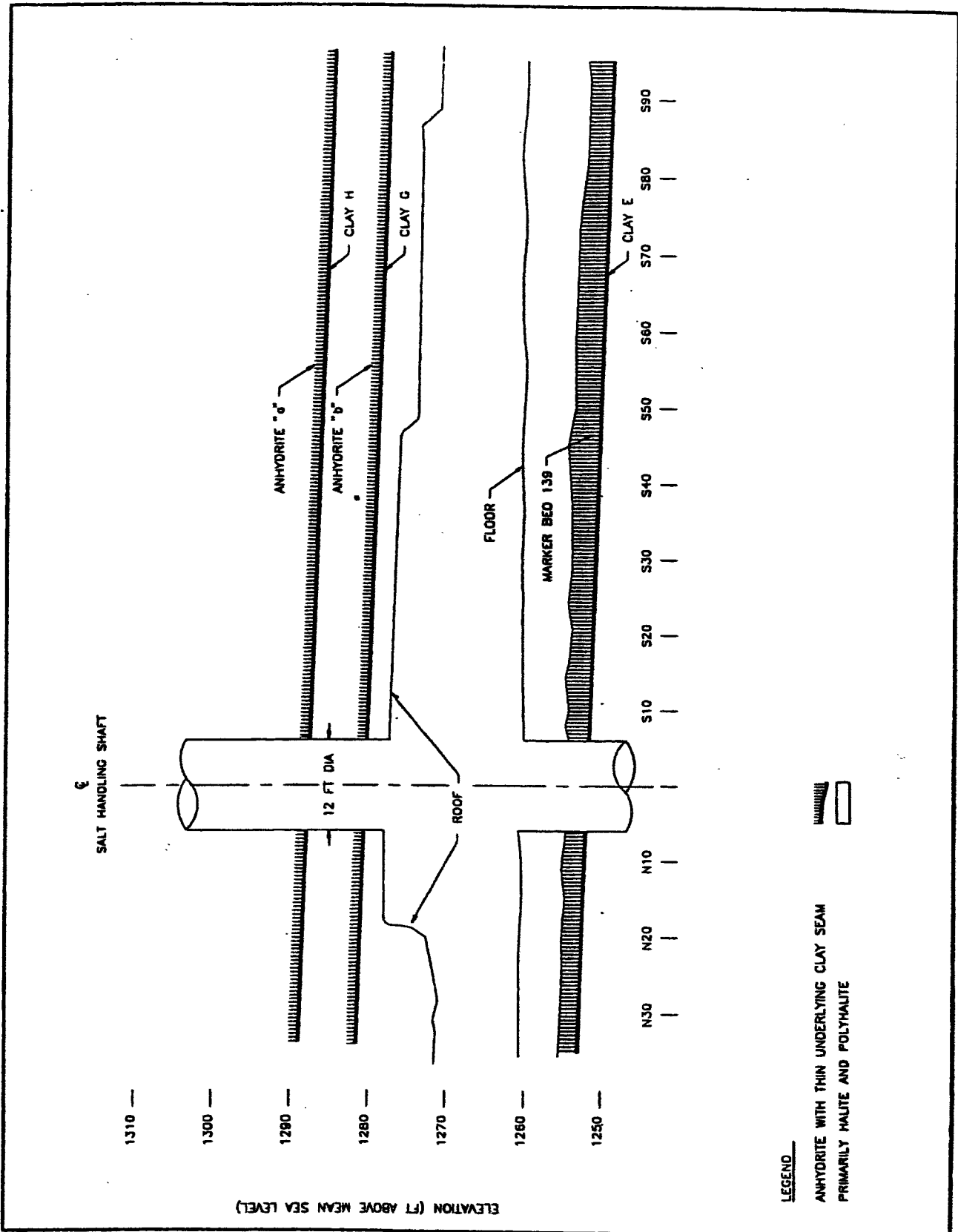

Figure 5
Salt Handling Shaft Station Profile Before Roof Beam Removal

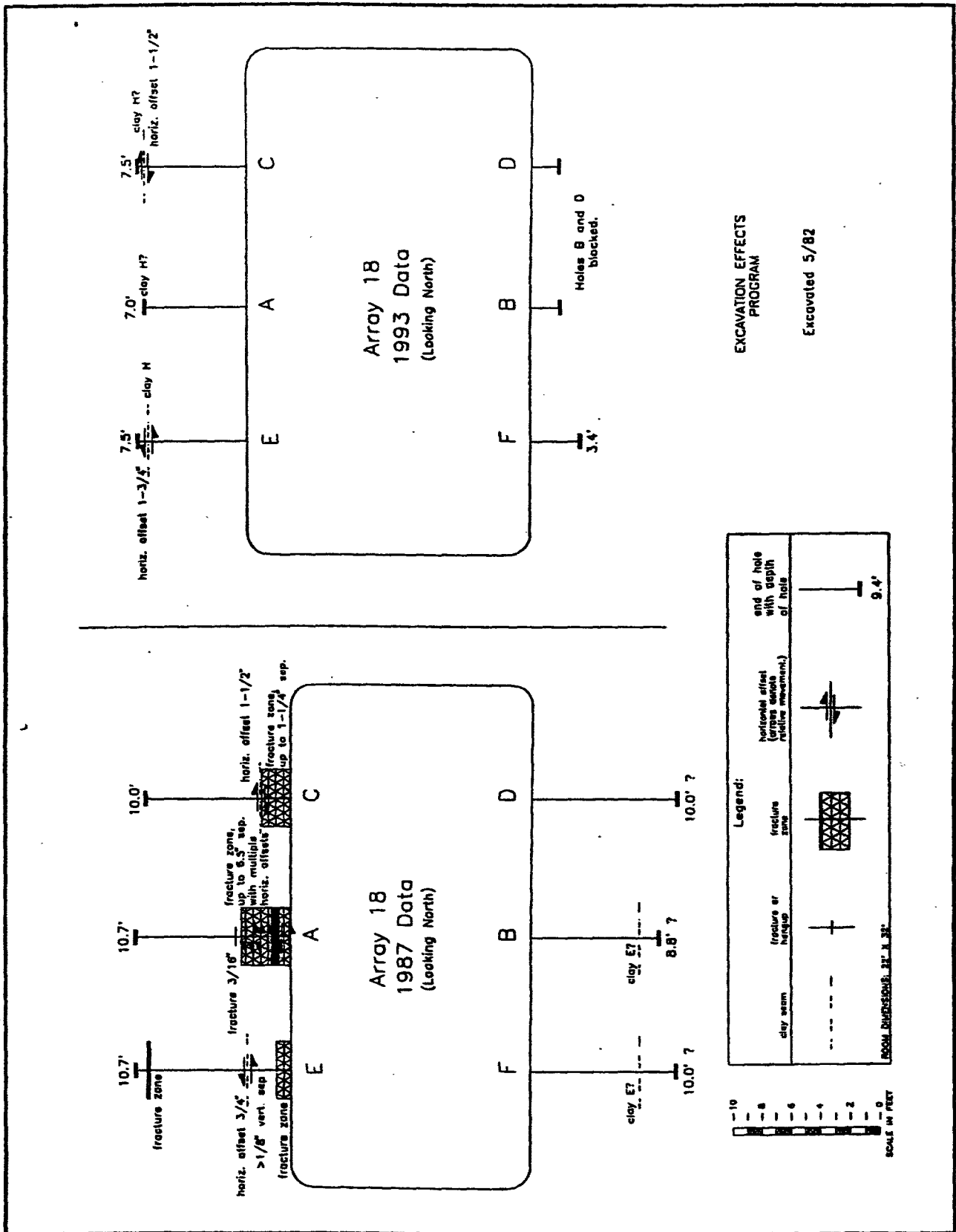

Figure 7
Salt Shaft Station Fracturing Comparison - 24 Feet South of Shaft

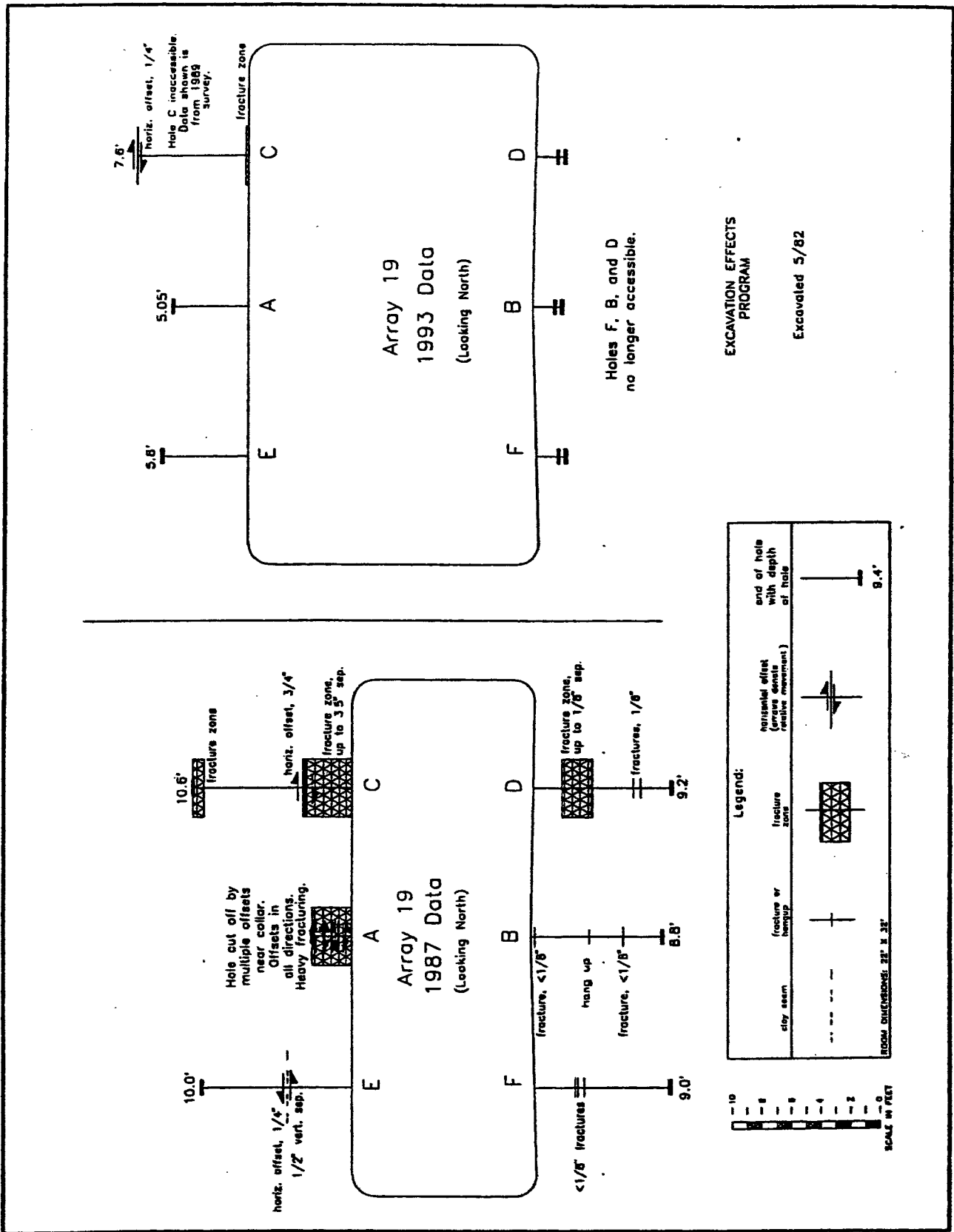
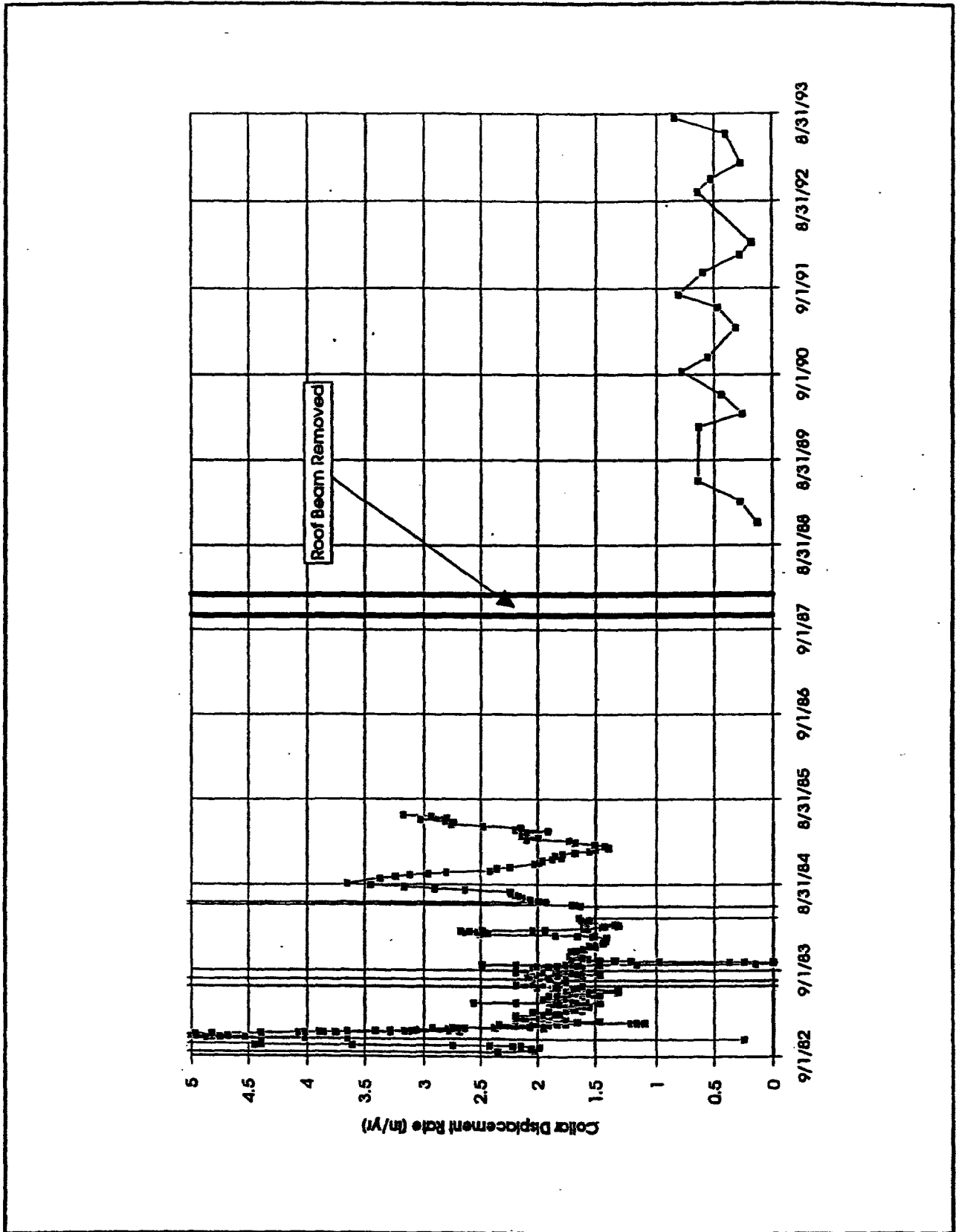

Figure 8
Salt Shaft Station Fracture Comparison 56 Feet South of Shaft



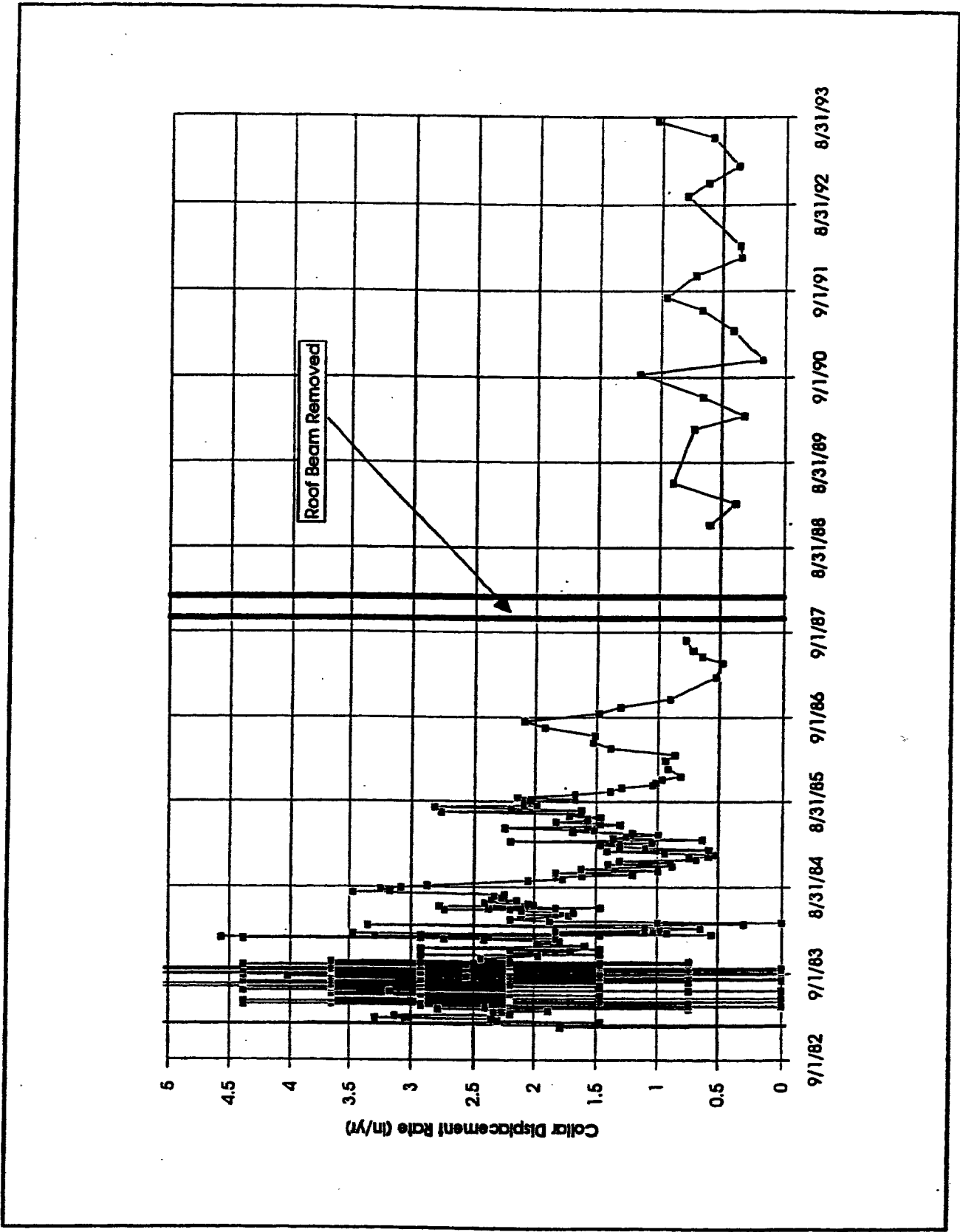

Figure 10
Salt Handling Shaft Station E0/S30 Roof Extensometer

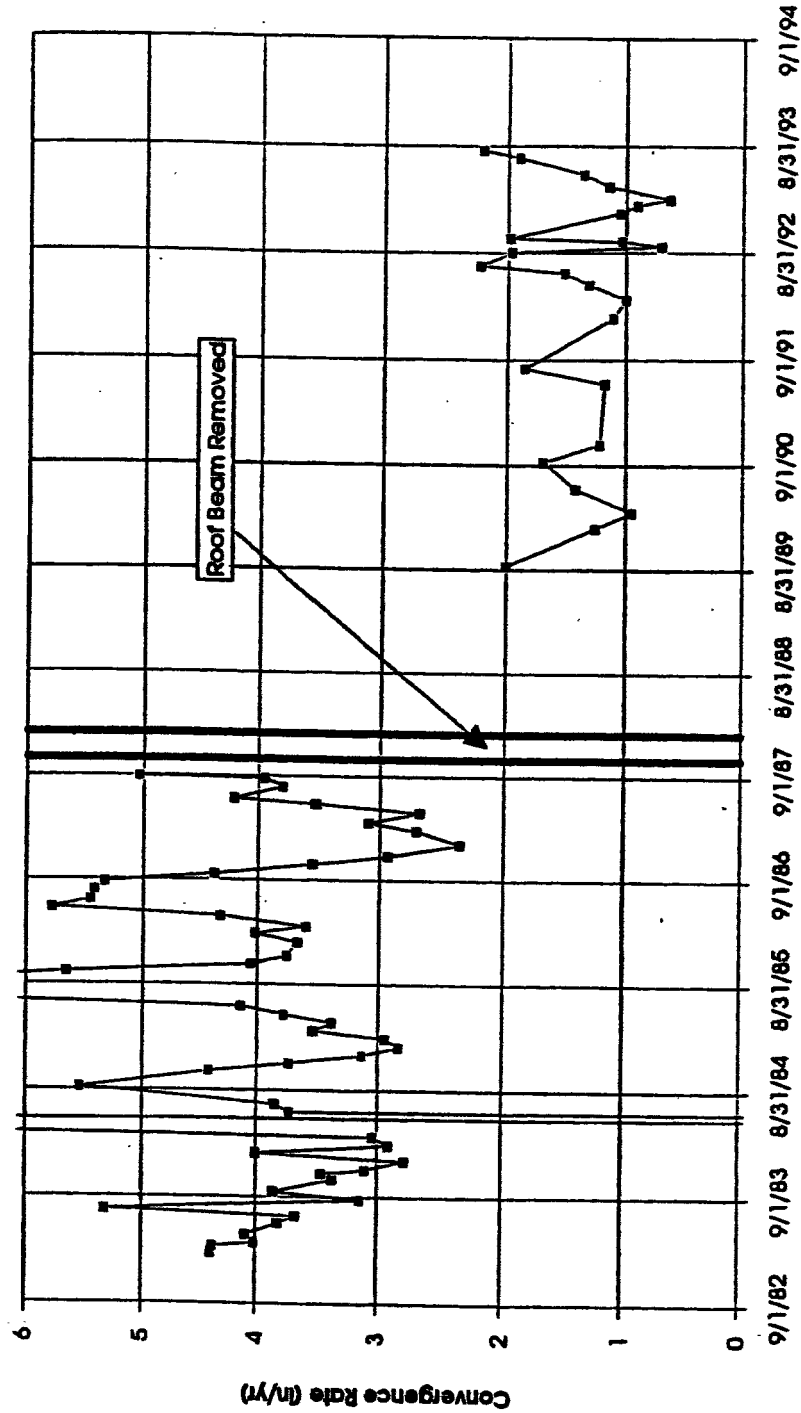

Figure 11
Salt Handling Shaft Station E0/S65 Vertical Convergence

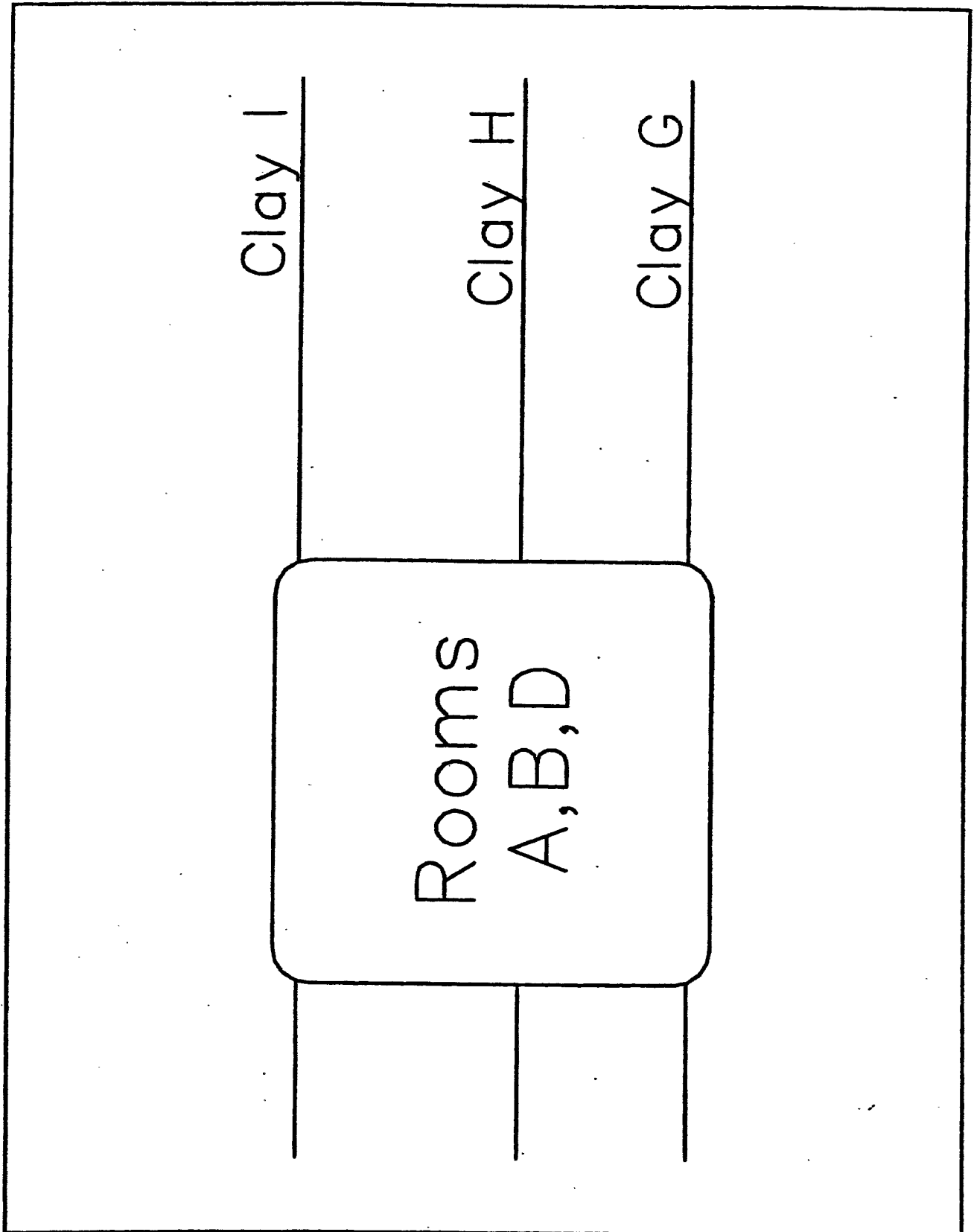

Figure 17
Stratigraphic Location of Rooms A, B, and D

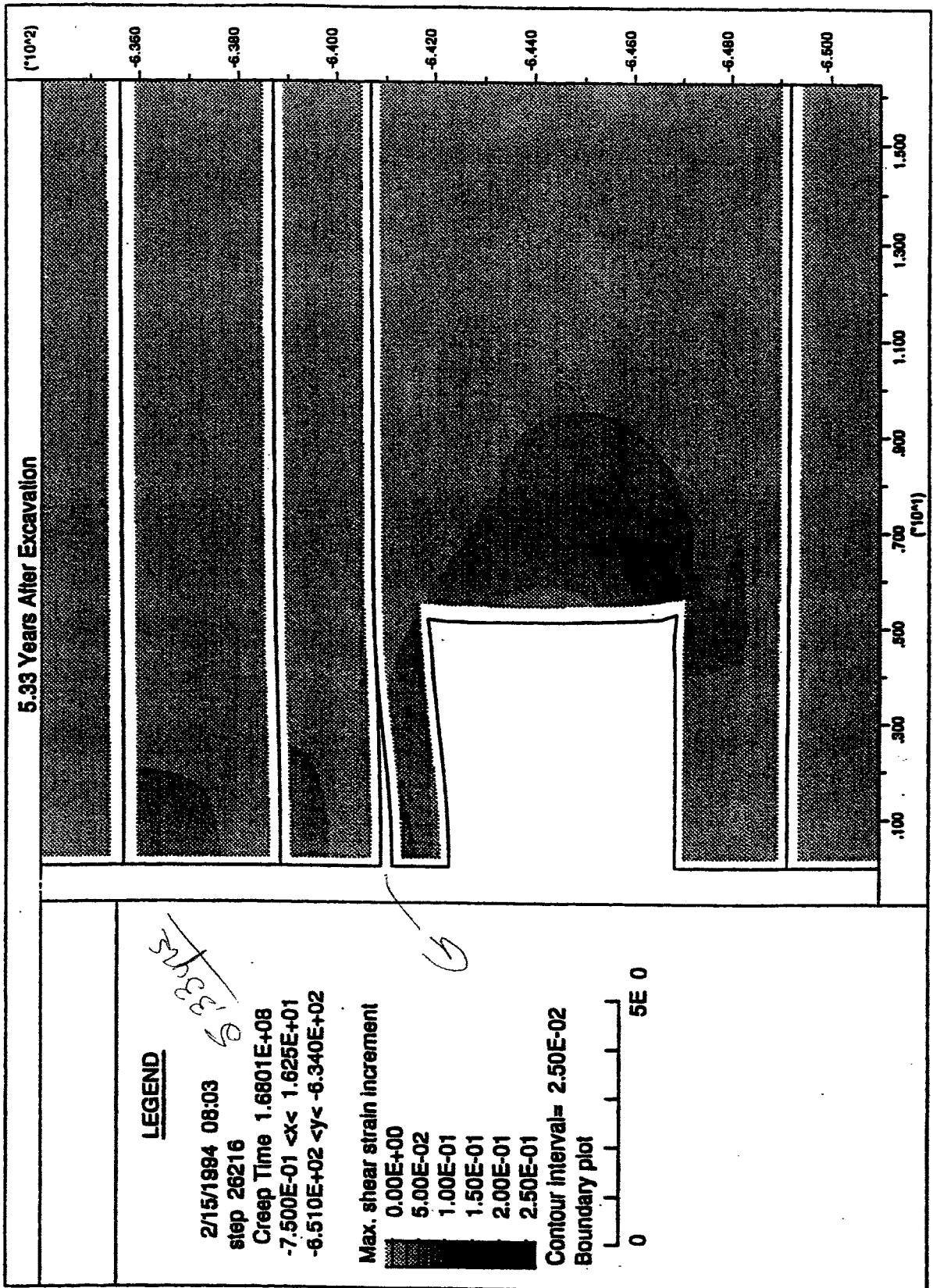

Figure 18

Model Results for Salt Shaft Station Before Roof Beam Removal

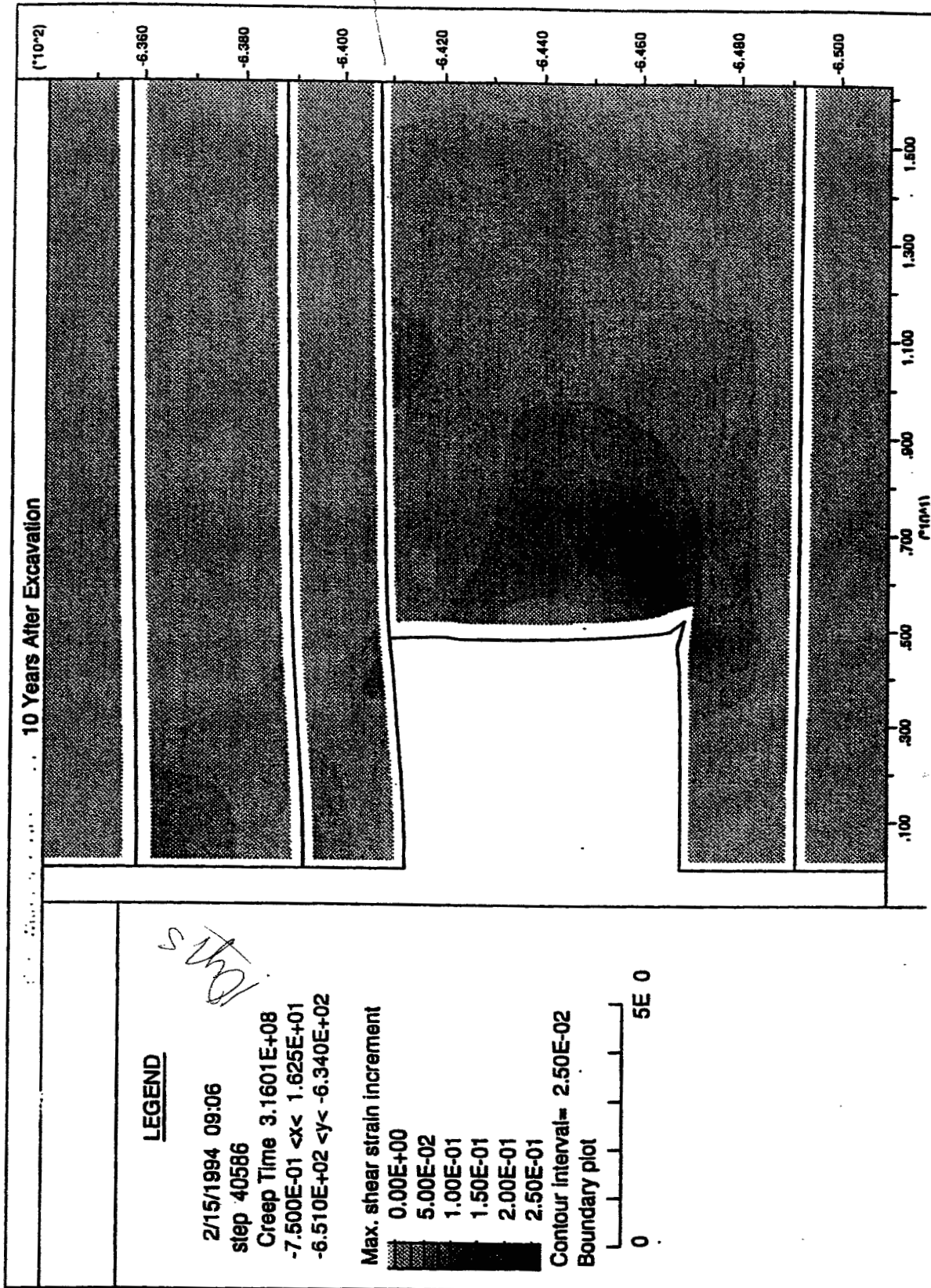

Figure 19
Model Results for Salt Shaft Station After Roof Beam Removal

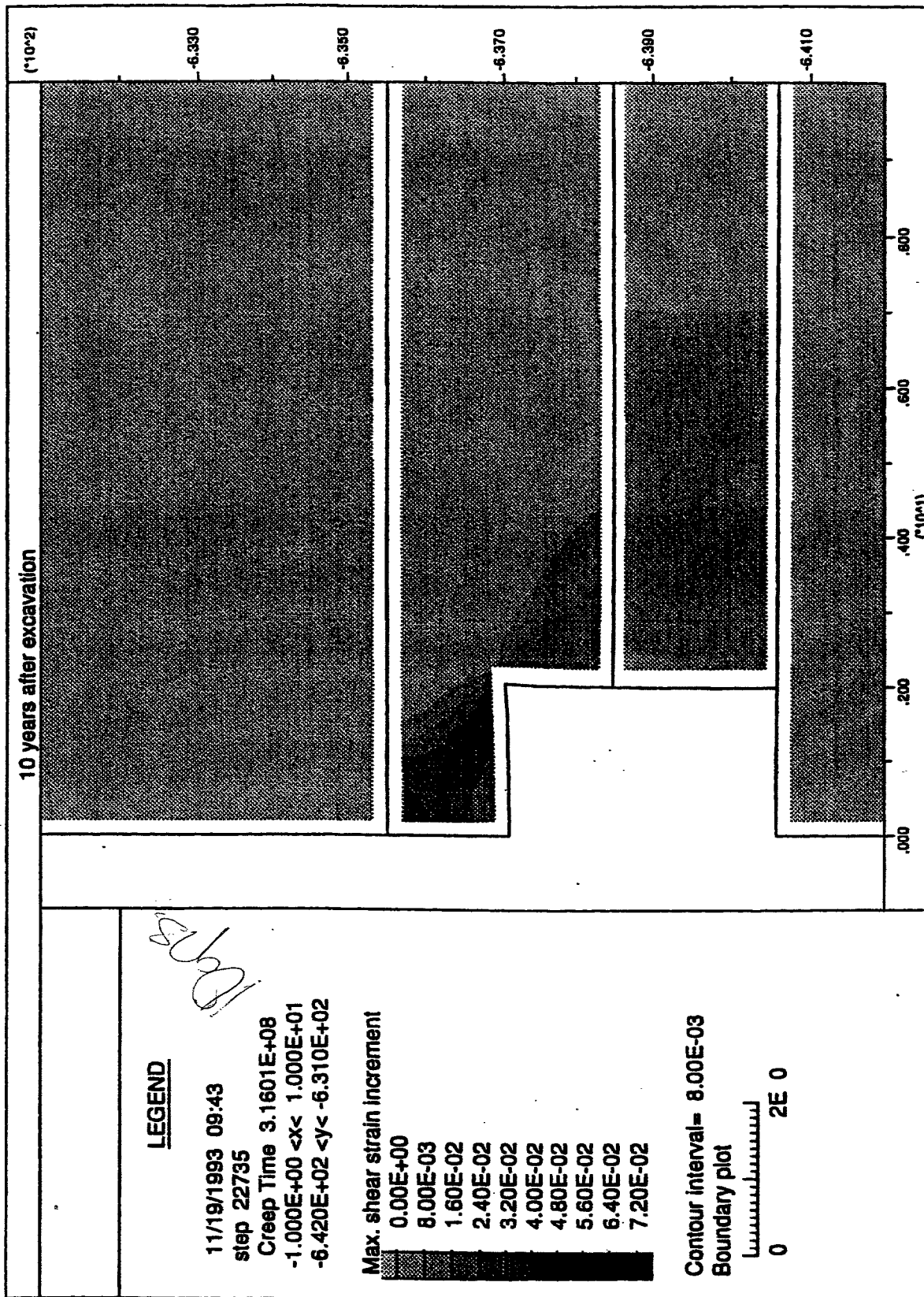

Figure 20
Model Results for N1420 Before Roof Beam Removal

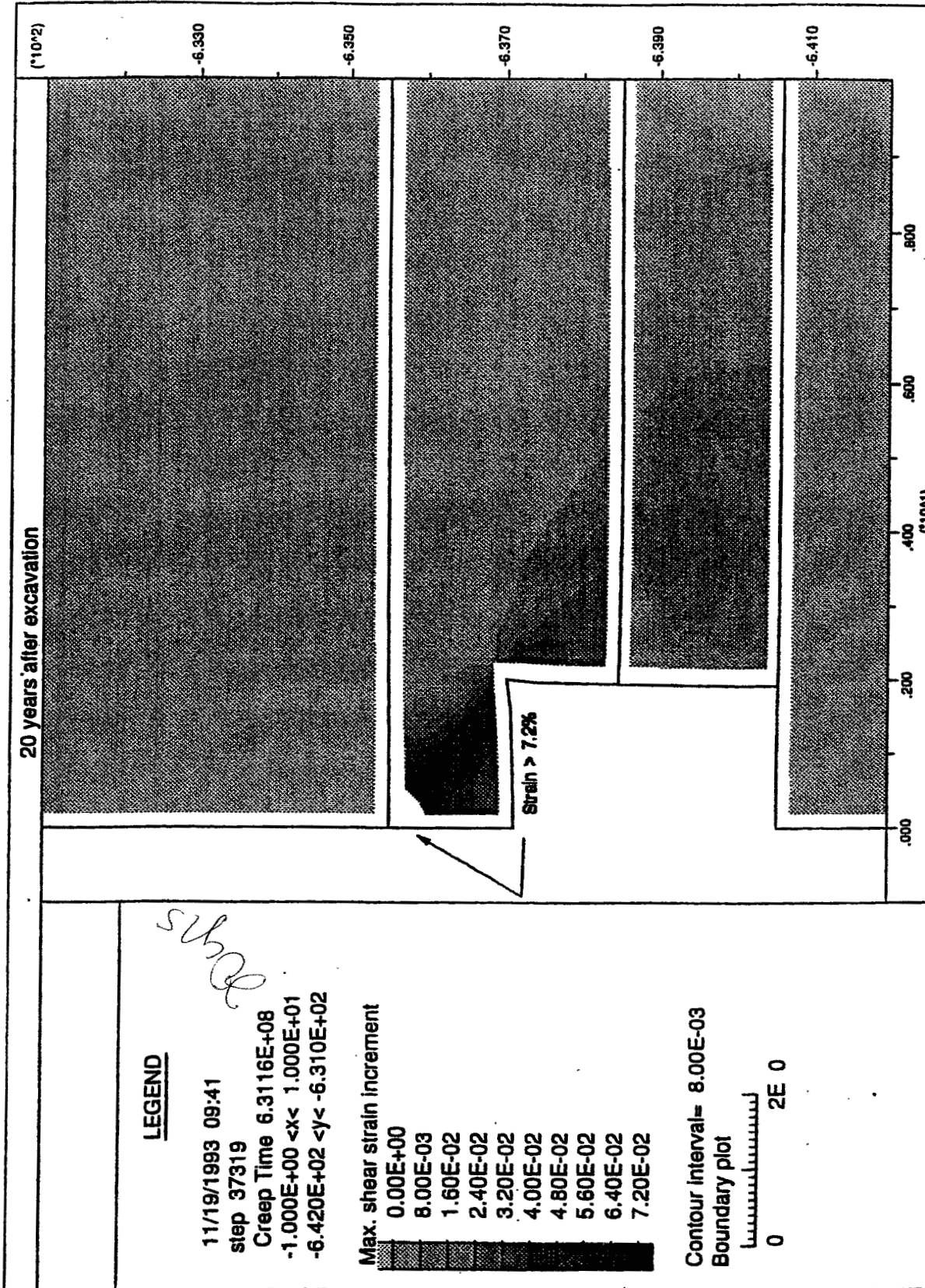

Figure 21
Model Results for N1420 Drift Without Roof Beam Removed

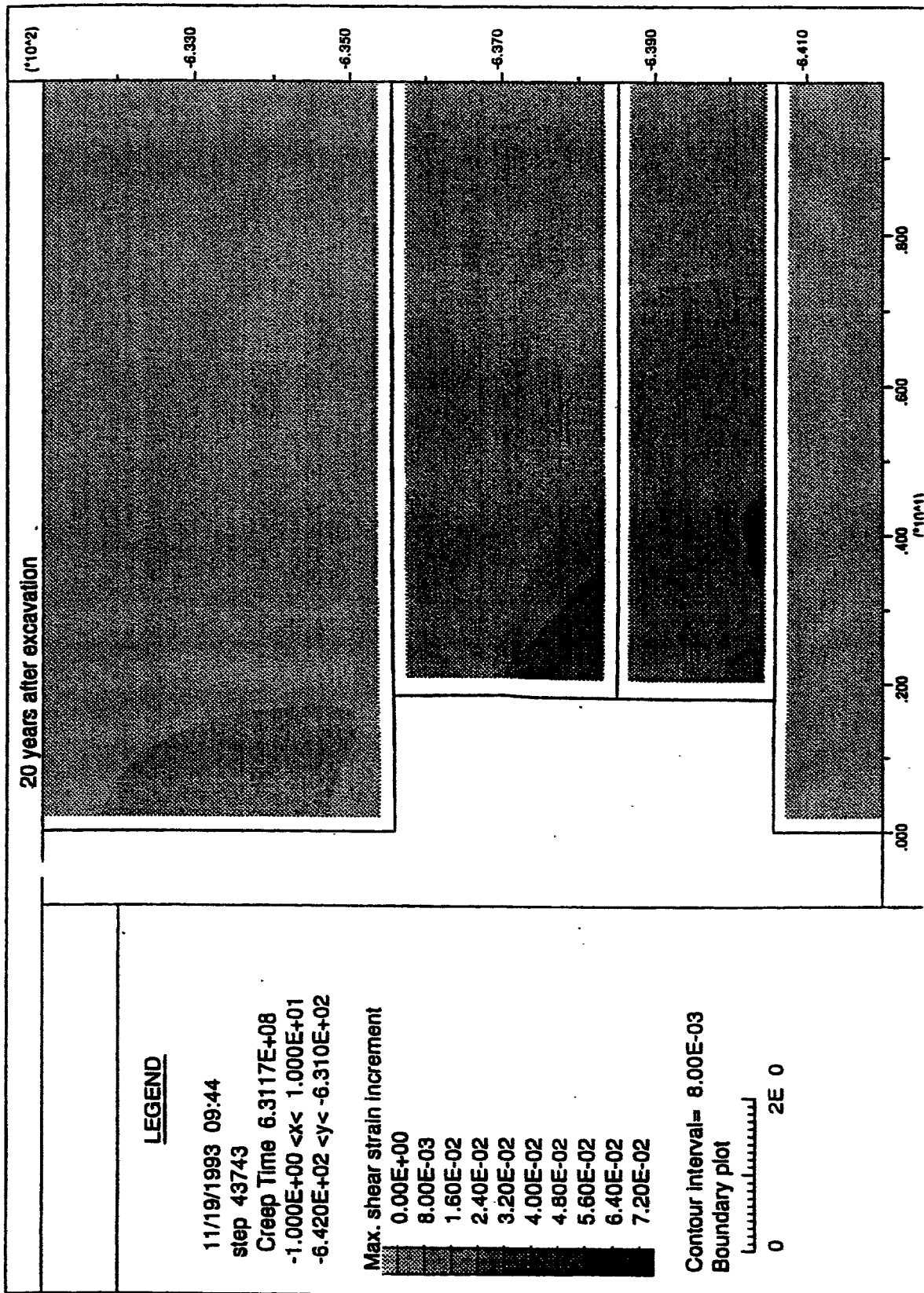

Figure 22
Model Results for N1420 Drift With Roof Beam Removed

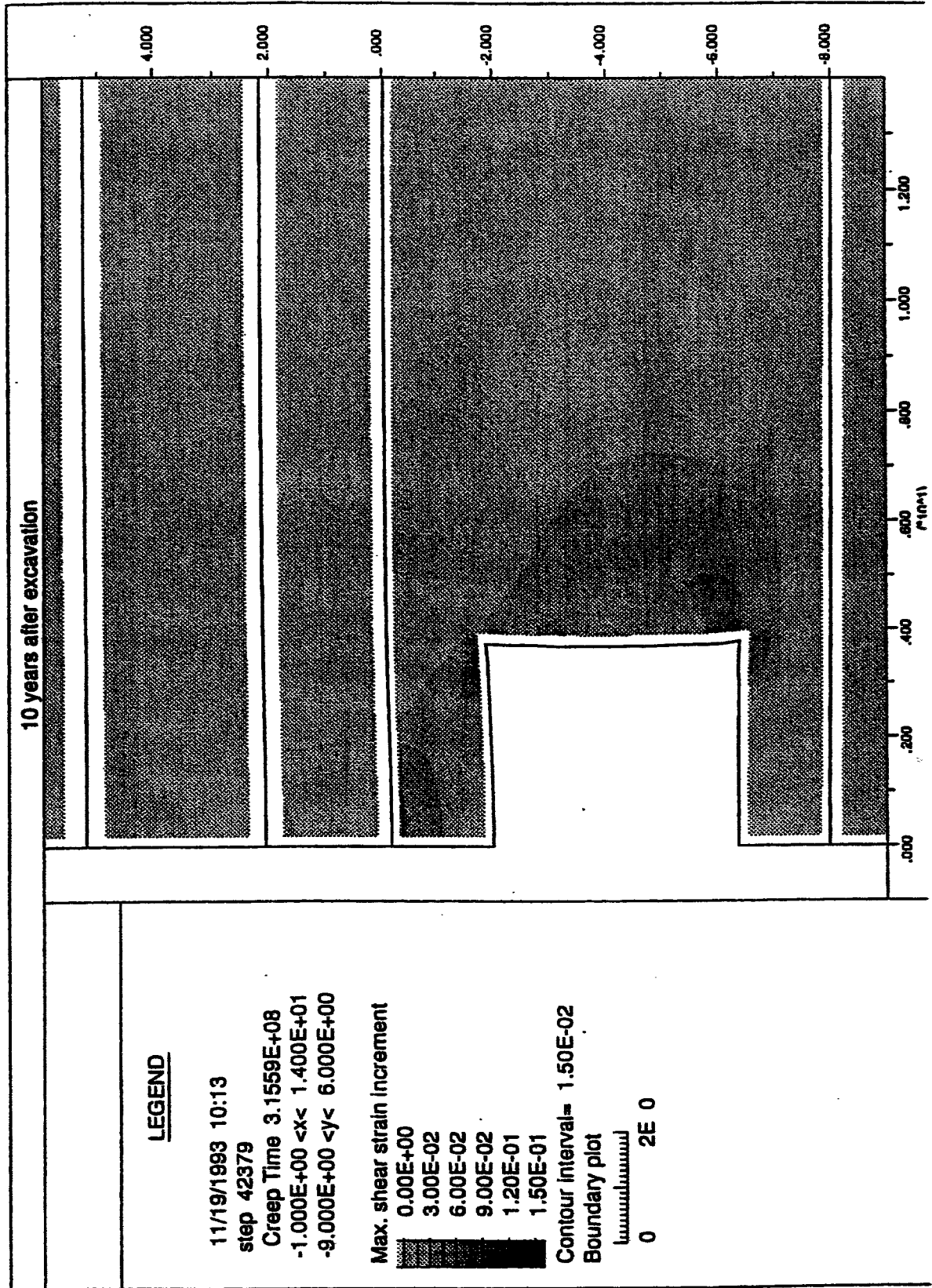

Figure 23
Model Results for E140 Drift Before Roof Beam Removal

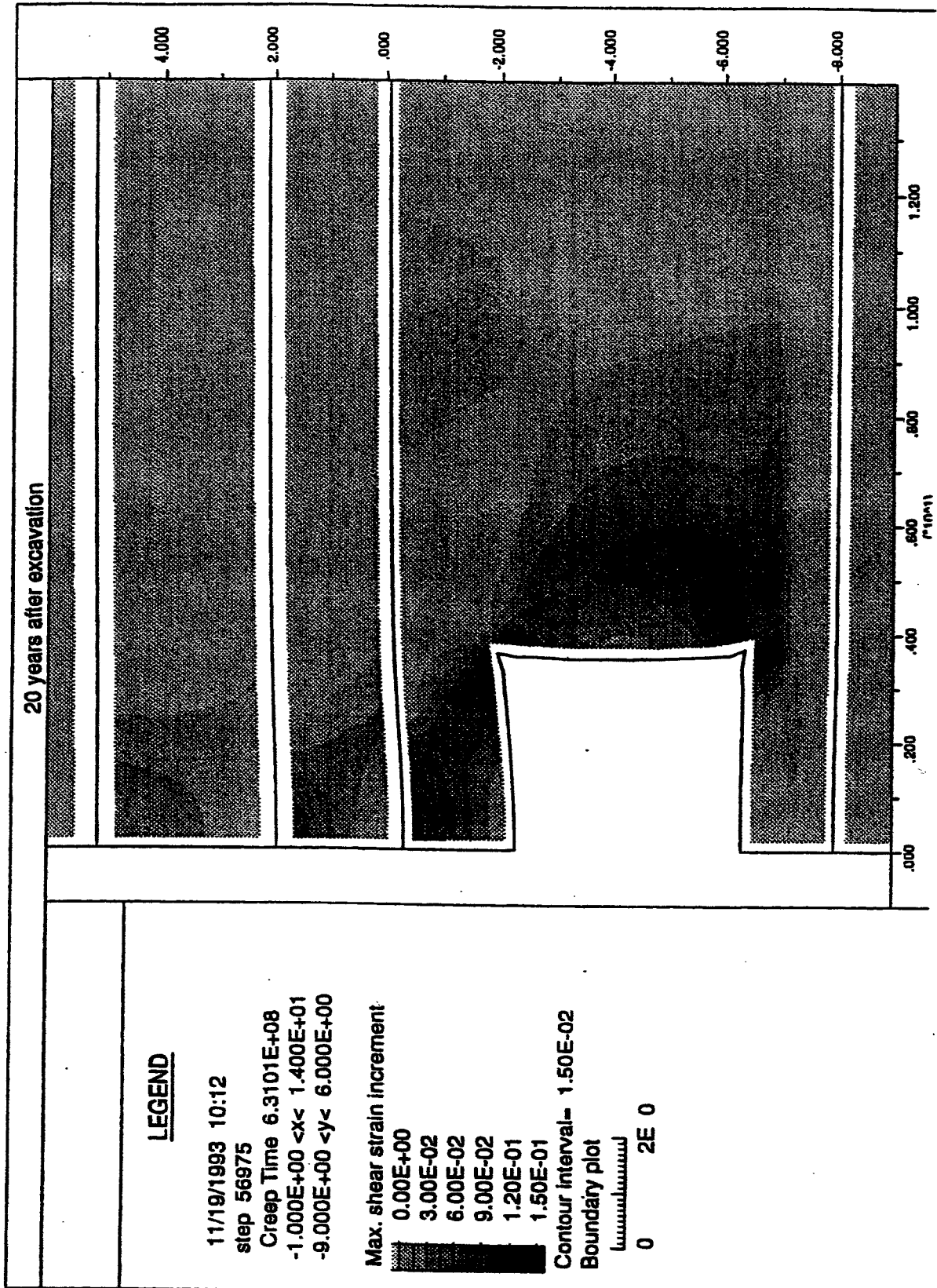

Figure 24
Model Results for E140 Drift Without Roof Beam Removed

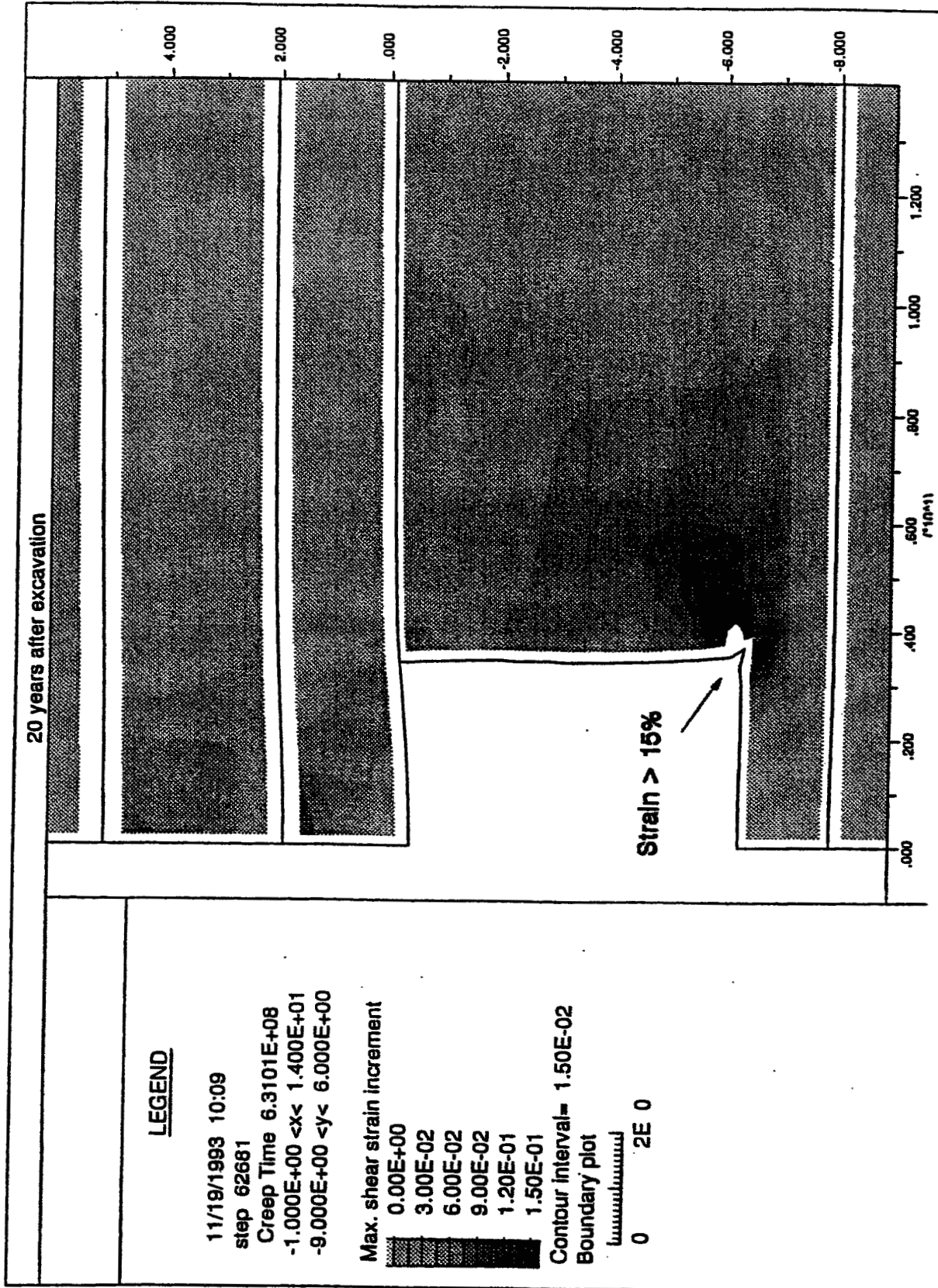

Figure 25
Model Results for E140 Drift With Roof Beam Removed

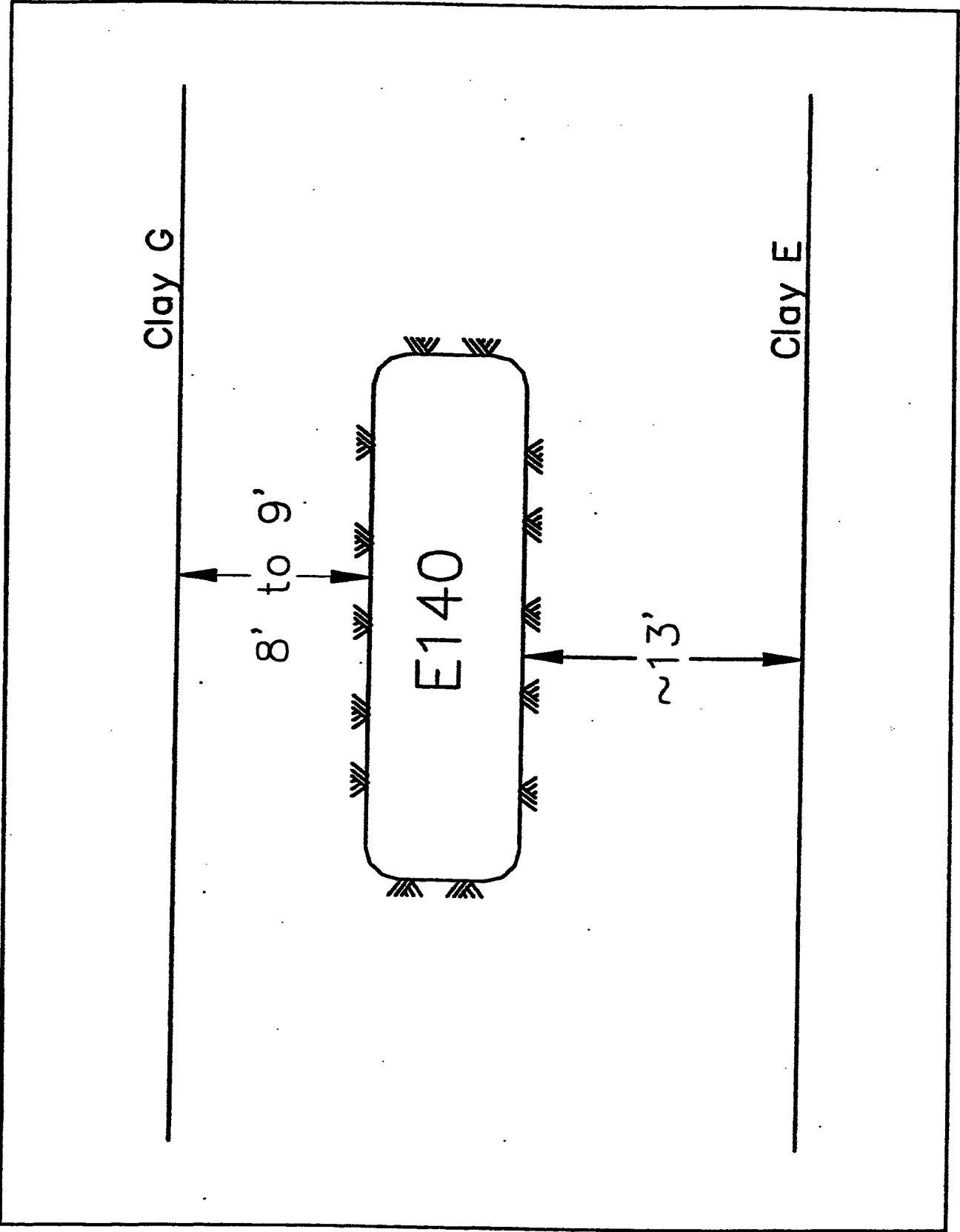

Figure 26
Stratigraphic Location of E140 Drift South of S2180

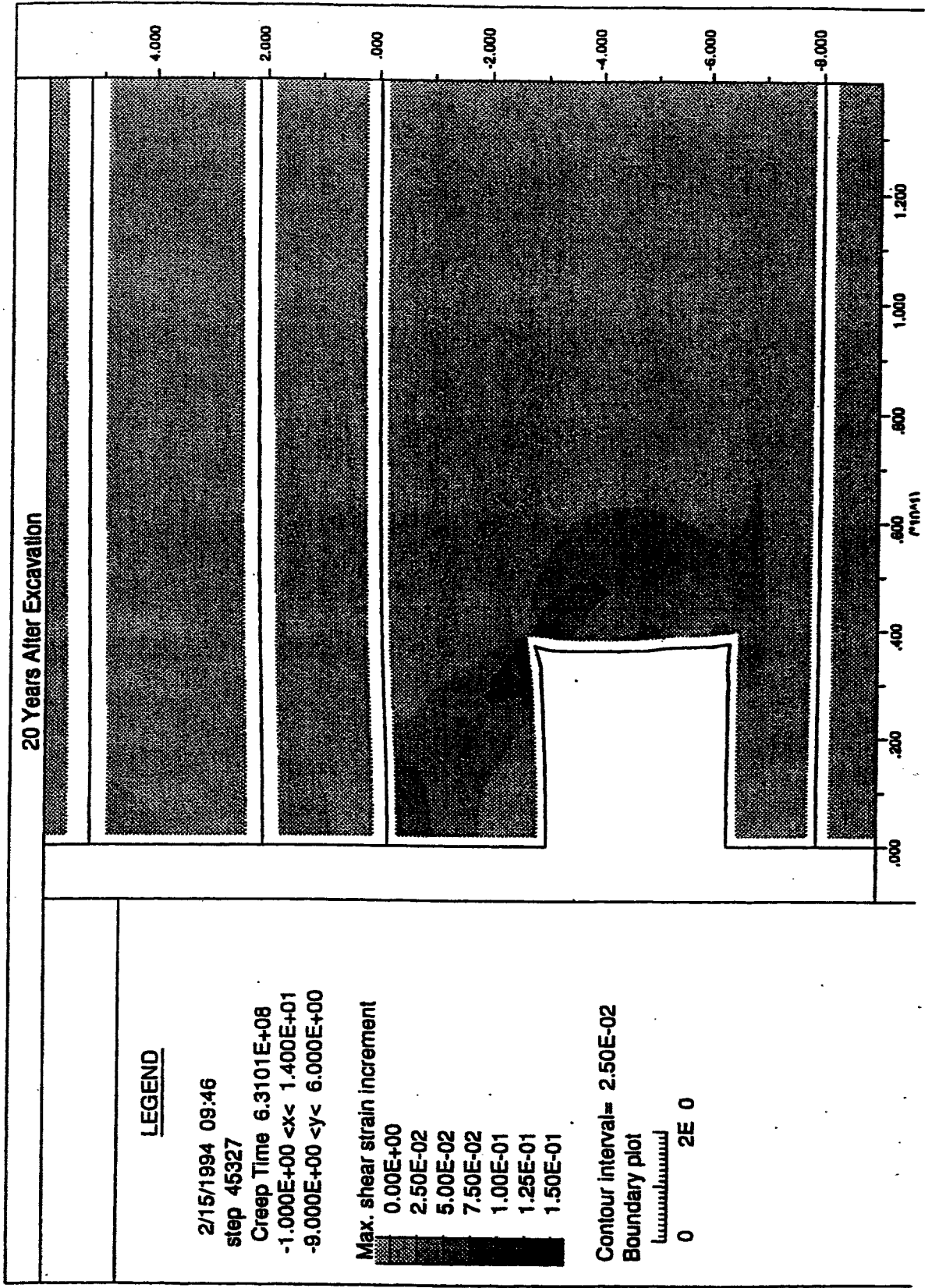

Figure 27
Model Results for South E140 Drift With Floor Lowered

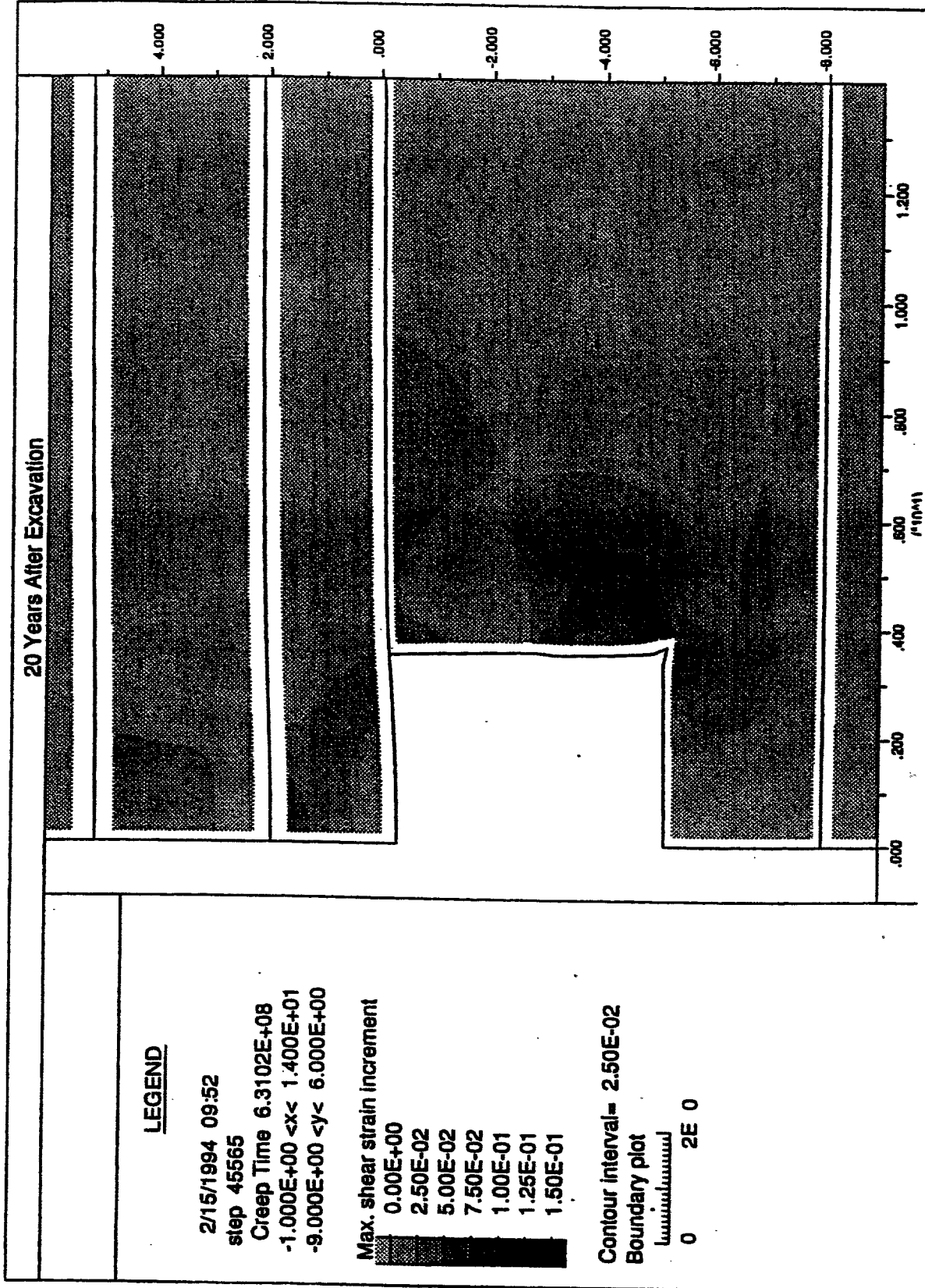

Figure 28
Model Results for South E140 Drift With Roof Beam Removed

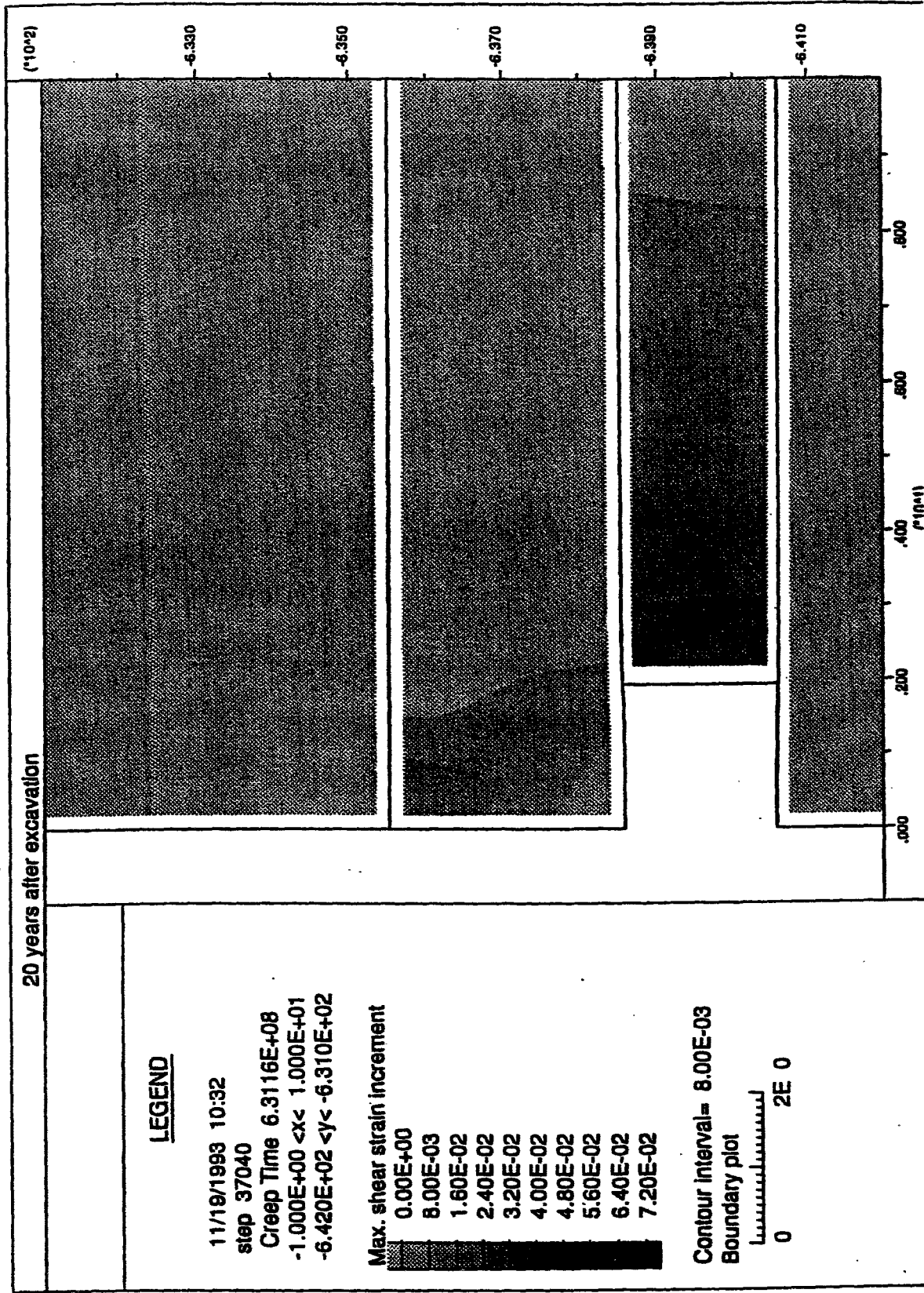

Figure 29
Model Results for N1100 Drift

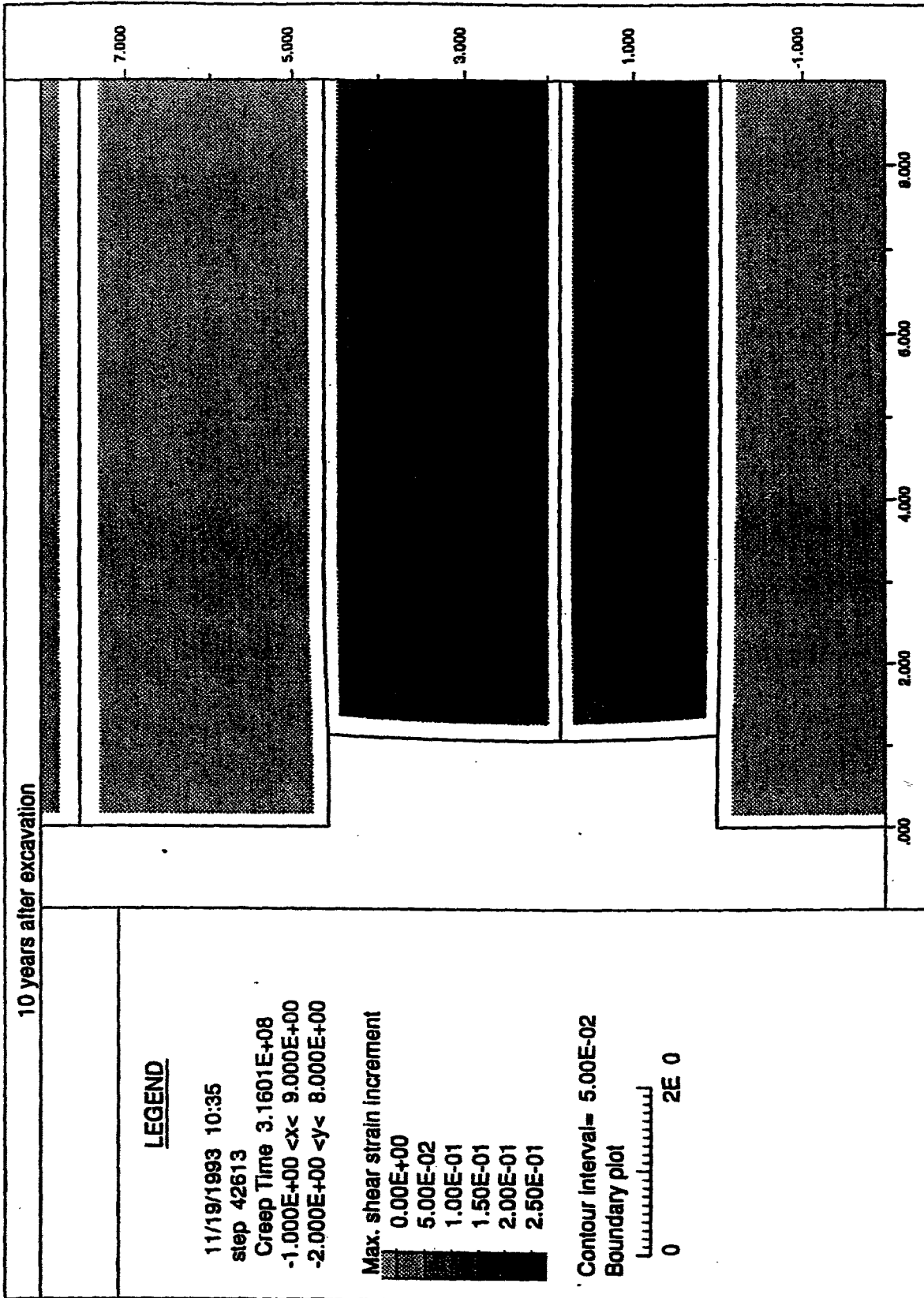

Figure 30
Model Results for Room D