

4-H Woodworking Series

Exploring Woodworking

Introduction

Do you wish you could turn a plank like myself into something you could use? Or maybe you want to make a wooden gift for a friend. Or perhaps you just want to learn how to use some tools. If so, this is the 4-H project book for you.



With this manual you will learn basic techniques for common tools. You will have the opportunity to build different projects including stilts and a paddlewheel boat.

There are six different sections called Skill Builders where a specific topic is focused on. Each Skill Builder has activities that will help you develop your skills. Once all the Skill Builders have been finished, there is a Showcase Challenge which allows you to exhibit the skills you have gained in any way you want to.



Find your protective eye goggles, ear plugs, and dust mask. We don't want any accidents. Once you are all suited up, let's start building our skills!



Table of Contents	
Introduction	1
Project Summary	2
Skill Builder 1: Safety First	3
Skill Builder 2: Measure Twice	6
Skill Builder 3: Hammerhead	9
Skill Builder 4: No Screws Loose	12
Skill Builder 5: Keep It Together	15
Skill Builder 6: A Strong Finish	18
Showcase Challenge	21
Portfolio Page	23

Woodn't You Know?

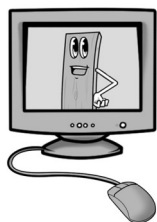

This Woodn't You Know? box will appear throughout the manual. Check out the great website link ideas wherever you see Woodn't You Know? These links will lead you to fun online content to help you with your 4-H project.

Meet Pip!

Pip the Plank will tell you neat and important information throughout your manual.

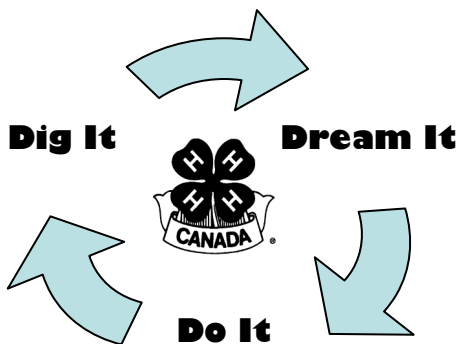

- Draft 2010 -

Learning is 3D!

To help you get the most out of your learning, each project meeting has the following parts:
Dream it! Plan for success
Do it! Hands on learning
Dig it! What did you learn?



What Skills Will You Learn?

Each section or Skill Builder (or Builder) in this project has activities that will help your project group learn to do by doing while learning new skills and having fun!



To complete this project, you must:

- Complete the activities in each Builder **OR** a similar activity that focuses on the same skills, as you and your leader may plan other activities.
- Plan and complete the Showcase Challenge.
- Complete the Portfolio Page.
- Participate in your club's Achievement (See the inside back cover for more information about 4-H Achievements)."

	Members will be able to...	Activities	Page
Skill Builder 1	Safety First	• Hazard Hunt	3
	• Understand how practicing safety can prevent injuries	• WHMIS	4
	• Identify the basics of wood processing	• Tools of the Trade	4
	• Recognize the fundamental tools	• Logs to Lumber	4
		• Tree Types	5
Skill Builder 2	Measure Twice, Cut Once	• Measure Up	6
	• Learn to follow a pattern	• Saw It	7
	• Measure and cut wood	• Brace Yourself	7
	• Understand what units are part of both the metric and imperial systems	• DeSign It	8
Skill Builder 3	Hammerhead	• One A Penny, Two a Penny	9
	• Understand the measurement system for nails	• Nailed It!	10
	• Select the correct nail and hammer for the job	• Stilts	10
Skill Builder 4	No Screws Loose Here!	• A Few Screws	12
	• Drill pilot holes	• Pilots in Training	13
	• Use a screw drive	• Toolbox Time	13
Skill Builder 5	Keep It Together	• Two Glues	15
	• Fasten pieces of wood using a hinge	• Clamping My Style	16
	• Fasten pieces of wood using glue	• Hinged Lid	16
	• Understand the difference between white and yellow glue	• Paddle Boat	17
Skill Builder 6	A Strong Finish	• Final Touch	18
	• Finish projects using basic techniques, including sanding, painting, and varnishing	• Wooden Birds	19
		• Tree Trial	19
When you successfully complete your builders, you will showcase what you have learned.			
Showcase & Portfolio	• Explain success in using the skills listed above	• Showcase Challenge	21
		• My Portfolio Page	23



Skill Builder 1: Safety First

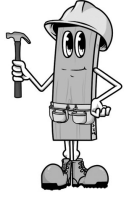

Pip Says....

No matter what project you're working on, the first thing to think about is safety. This builder will help you make sure no one gets hurt while using tools and working with wood.



SKILLS CHECKLIST

- Understand how practicing safety can prevent injuries
- Identify the basics of wood processing
- Recognize the fundamental tools

Important words

Watch for these important words throughout this builder:
Personal Protective Equipment (PPE), Sustainability, Softwood, Hardwood

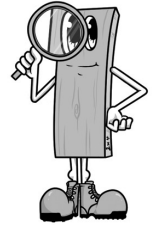

Dream it!

To begin any project and be successful you need to plan. In Dream It! you will begin thinking about the topic that the builder explores.

Wooden Surroundings

Look around you. Count the number of things you can see made of wood. _____
 What steps do the products go through to become what you see around you? Draw pictures between the arrows to show your guesses of what happens between trees and your home.

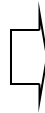

Do it!



Hazard Hunt

Take a walk around your workspace and check off each item to make sure you will be safe.

- Wood stored safely
- Tools are in good condition
- There is appropriate ventilation
- Lighting is adequate
- There are trashcans for disposal
- Chemicals are stored safely



Pip Says....

Try doing your shoelaces up without your thumbs. Accidents are preventable and by remembering the safety rules, you can make sure you never have to do that again.



- The area is tidy
- There is a first aid kit
- Fire extinguisher is nearby
- The work surface is stable and secure
- The work surface is smooth and free of snags
- The work surface does not have nails or metal parts

Pip Says....

Safety can involve a lot of things in the workshop. Equipment to wear includes: hearing protection, goggles, a shop apron, steel toe boots, rubber or latex gloves (when applying a finish), and a respirator or dust mask. Luckily, you were born with the best defense against accidents - common sense. So, make sure to use it!



EXPLORE

Symbol

To keep people safe while using products in our shops, the International Safety Symbols were created to label products according to their level of threat and type of danger. Take a look around the shop and check off each symbol that you find.

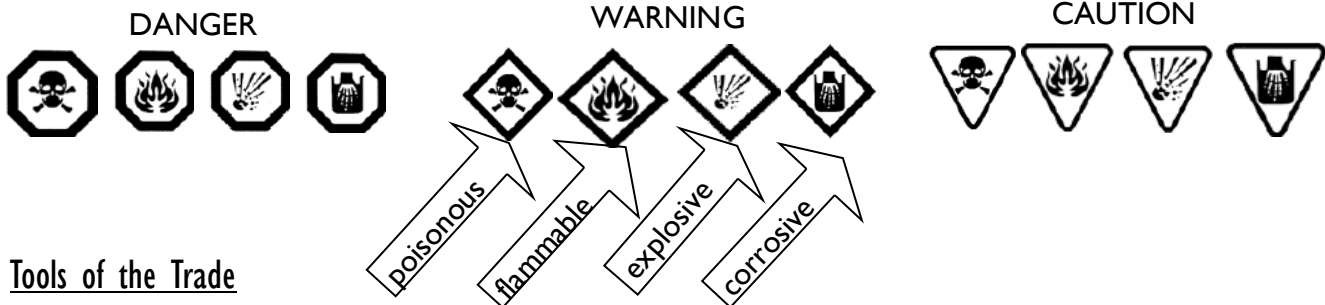

Tools of the Trade

Match the picture of these common woodworking tools with the number beside the proper name.

1. C-clamp
2. Claw Hammer
3. Coping Saw
4. Electrical Drill
5. Flat-bladed Screwdriver
6. Hand Drill
7. Handsaw
8. Pencil

FROM THE OLD CANADIAN
MATCH THE NAMES OF THE
TOOLS WITH THOSE IN THE
DIAGRAM. CARRIE WILL SCAN IN

9. Phillips Screwdriver
10. Pliers
11. Power Saw
12. Sandpaper Block
13. Tape Measure
14. Try Square
15. Wood Rasp

Logs to Lumber

Visit a place that is involved in turning trees into a finished product. Whether it is a logging camp, a paper mill, or a lumber yard, see what you can learn about the process of changing wood into a useable product. If you are unable to visit in person, try doing some research on the internet. Write three things you learned below.

-
-
-

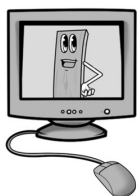

Woodn't You Know?

To visit a steam powered saw mill in B.C. on the internet, go to:
<http://www.alberniheritage.com/virtual-map/virtual-map.php> or
<http://www.alberniheritage.com/mclean-mill/virtual-tour> for 360° images.

Tree Types

Trees are classified depending on their hardness, and are usually labeled as hardwood or softwood. Hardwood comes from deciduous trees (the ones with big bushy leaves that lose their leaves in the fall) like ash, birch, hickory, oak, maple, poplar, rosewood, and walnut. Softwood comes from coniferous trees (the ones with needles or thin leaves) like cedar, cypress, fir, pine, redwood, and spruce. Softwoods are cheaper than hardwoods and are usually a good choice for a beginning woodworker. To test if a piece of wood is hardwood or softwood, you can push a ball point pen into it and see how easily it dents. The easier it dents, the softer the wood. Pick two types of wood to research and fill in the chart below. Ask your local hardware shop about the costs. An example has been done for you.



Species	Hardness	Colour	Major Use	Cost(\$)/Board Foot
<i>Mahogany</i>	<i>Hardwood</i>	<i>Reddish</i>	<i>Furniture</i>	



Dig it!

How can you make sure you stay safe during this project? Make a safety goal to help you keep all ten fingers and all ten toes.

My Safety Goal:



Compressed Gas



Oxidizing Material



Flammable and Combustible Material

Other safety symbols used in the shop are WHMIS (Workplace Hazardous Material Information System). If you see any of these symbols of products you are using, make sure to talk with your leader about extra safety precautions.



1. Materials Causing Immediate and Serious Toxic Effects



2. Materials Causing Other Toxic Effects



3. Biohazardous Infectious Materials



Corrosive Material



Dangerously Reactive Material

What's next?

Skill Builder 2 will help you learn to follow a pattern through careful measurement. You will also learn to use the handsaw, coping saw, and brace and bit, as well as make a sign!

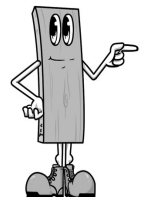

Skill Builder 2: Measure Twice, Cut Once



Pip Says....

Measuring carefully is a big part of being a master woodworker. Canadians have used the Metric System where everything is based in multiples of 10 since 1970 but Americans still use the Imperial System. This is why we need tools in both inches and centimeters.

SKILLS CHECKLIST

- Learn to follow a pattern
- Measure and cut wood
- Understand what units are part of both the metric and imperial systems

Important Words

Look out for these important words in this builder:

Saw, Clamp, Kerf, Metric, Imperial, Drill, Utility Square, Try Square, Framing Square, Combination Square

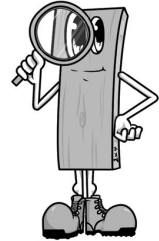

Dream it!

How Do You Measure?

Circle the answer to the first two questions and write what you think for the last question:

- 1) What units do you measure your weight in? **pounds kilograms ounces grams**
- 2) What units do you measure your height in? **feet metres inches centimeters**
- 3) How would you measure a piece of wood?

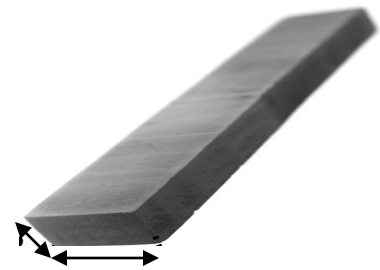

Do it!

Measure Up

Match each description with the picture of the measurement tool. Then use each tool to make sure you can use them correctly. You might also want to try a framing square, also called a utility square.

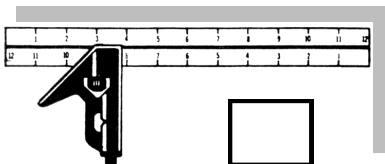

A) A Measuring Tape is a small tool can measure a curved surface in both Metric and Imperial as well as straight surfaces.

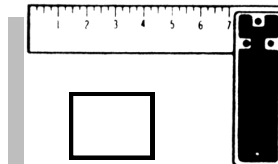

B) A Try Square is used to test if two surfaces are at a 90° or right angle. Most projects require pieces to come together at right angles.

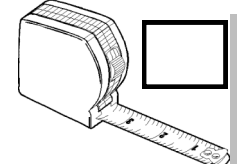

C) A Combination Square is used to check is a board is flat or level, to measure depth, to check angles, and to draw a line parallel to the edge of a board.

Saw It

There are a few types of hand saws you will use throughout this project: the crosscut saw, the rip saw, and the coping saw. The crosscut saw and rip saw cut straight through wood whereas the coping saw has a thin blade that can be used to make round cuts. The crosscut saw cuts across the fibres and has more teeth than a rip saw, which cuts with the fibres. The crosscut saw and rip saws cut when you push but the coping saw cuts when you pull. Match the parts of the hand saw and the coping saw. Then practice using each type of saw. When using the coping saw, draw a shape with rounded edges on a piece of wood (perhaps a circle or heart), and try to cut it out as best you can.

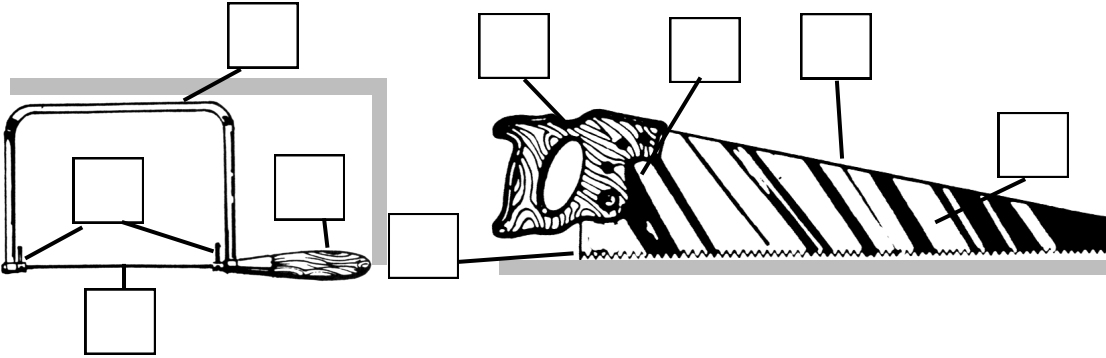

EXPLORE

- 1) Back
- 2) Blade
- 3) End Pieces
- 4) Frame
- 5) Handle
- 6) Handle
- 7) Heel
- 8) Teeth
- 9) Toe

From Farming History...



In order for a team of oxen to plow a field, they needed to be joined by a yoke. This yoke was easily constructed by amateur woodworkers, and most farmers were a woodworker of some skill.

The kerf is the path the saw cuts through the wood. The teeth of the saw bend from side to side leaving a kerf wider than the saw. To make sure this does not affect your measurement, always saw on the waste side of your marking line.

Fun Facts!

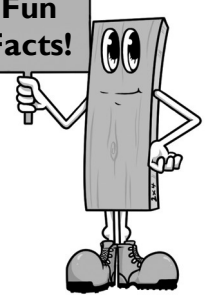

Brace Yourself

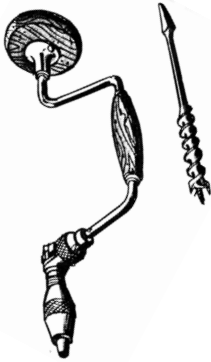

Before you can move on to power drills in the Discover level, you need to learn the technique on the ancestor of the power drill - the brace and bit. The brace is the large part that is manually turned to drive the bit into the wood. Bits come in many sizes but they all work in the same way. Hold the brace and bit straight up and down when drilling and make sure to have a piece of scrap wood underneath so that you do not damage your work surface if you go all the way through. Rotate the handle around until the bit is in as far as you want. You may want to mark on the bit the depth you want to drill so you do not go too far. Once your hole is the correct depth, pull it straight up and out. Practice drilling holes of different depths and widths. You will continue to use the brace and bit to drill pilot holes to help the screws go in easier in Builder 4.

Woodn't You Know?

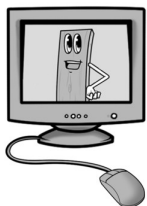

Countries have been converting to metric since it was invented in France in 1795. Only the U.S., Myanmar (Burma), and Liberia still use Imperial. To learn more about who converted and when, visit: <http://lamar.colostate.edu/~hillger/internat.htm>

DeSign It

Use your brace and bit to drill holes into a piece of wood, but first create a pattern that you can trace onto your piece of wood. You might want to write your name or a favourite word. Show your design below. An example is in the corner.



2) Pull out your coping saw and make a design of bubble letters to cut out. Show your design in the box below too. An example is in the corner. Keep your signs to finish in Builder 6.

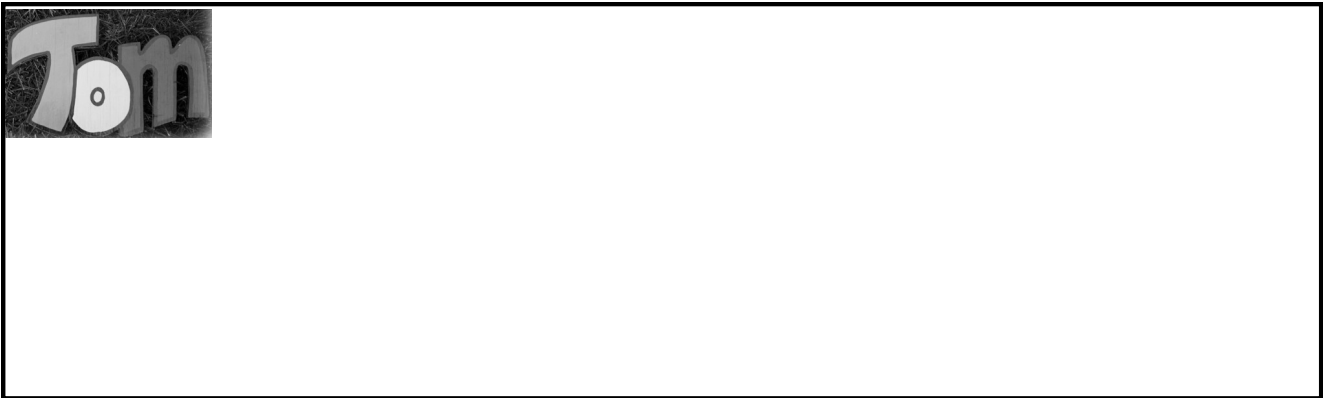

Dig It!

Think about the builder and the activities you did...

Do you prefer the Metric (metres, grams, Celsius...) or Imperial (feet, pounds, Fahrenheit) System?

Which saw do you find easier to use? Why?



What's next?

Hammers and nails are one of the most common tools to put pieces of wood together. You will also build a pair of stilts that you can use to walk around on.

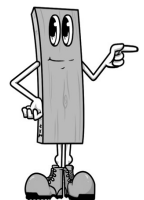

Skill Builder 3: Hammerhead



Pip Says....

Hammers are one of the oldest tools in the world, dating back to 2, 600, 000 BC. The modern claw hammer can be used to pound nails in or pull them out using the other side of the head. You should always wear safety goggles when using a hammer!



SKILLS CHECKLIST

- Understand the measurement system for nails
- Select the correct nail and hammer for the job

Dream it!

Nail Knowledge

Fill out the know and want to know boxes about hammers and nails. The learned box will be filled out in the Dig It! section of this Builder.

Know	Want to Know	Learned

Important Words

Watch out for these important words in this builder:

Hammer, Nail, Penny, Common nail, Finishing nail, Clamp



Do it!

One a Penny, Two a Penny



Nails are measured in a system called penny, represented by the letter "d". A 1.5 inch long nail is also known as 1.5 d. However, nails that are shorter than 2 inches long are also measured by wire gauge between 17 and 20, with the bigger the number being, the thinner the nail. Two types of nails you will use in your project are the common nail and finishing nail. The common nail has a larger head than the finishing nail. A nail set is used to push the finishing nail further into the wood so that the hole can be covered with putty.

Work with your leader to organize nails according to their size and discussing how they are labeled.

To straighten a bent nail, hold a block of wood against the nail and then tap the nail repeatedly against the block. Don't try to straighten it all in one swing, unless it only has a very small bend. Nails go into dry wood more easily if they have been dipped in a bit of wax. You can drill a small hole in the end of your hammer and fill it with melted paraffin, so the wax is always handy for you!

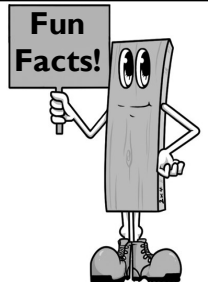

Nailed It!

The ability to use a hammer and a nail is one of the most important woodworking skills. Hammers come in many different shapes and sizes and you should choose one that doesn't feel too heavy. It is important to wear eye protection, make sure the hammerhead is securely fastened, and tie long hair back. To hammer:

- 1) Hold the nail in the desired spot with one hand
- 2) Swing the hammer from your wrist and tap the nail lightly.
- 3) Once the nail stays in the wood by itself, remove your holding hand.
- 4) Hold the hammer at the lower end of the handle and use your whole arm for the most power (this may take time to perfect).
- 5) Keep the handle of the hammer at a right angle to the nail while driving to make sure you don't bend the nail.
- 6) Keep your eyes on the nail and hit it squarely on the head.

EXPLORE

Word Bank

1. check
2. claw
3. face
4. handle
5. head
6. neck
7. poll

Fill in the numbers of the words with the correct hammer parts.

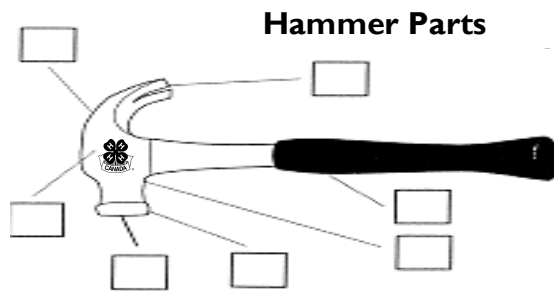
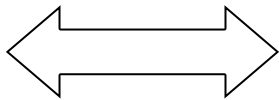

Stilts

Materials:

- 1 scrap 2 x 4, at least 16" long
- 2 scrap 2 x 2s, at least 60" long
- 1 scrap 1 x 2, at least 16" long
- 4 hex bolts, 3/8" x 7"
- 4 3/8" washers
- 4 3/8" wing nuts
- wood glue
- sandpaper, 100 grit

Tools:

- square and pencil
- handsaw
- hammer
- protective eye wear
- brace with 3/8" bit

Cut List:

- 2, 2x4x6" (steps)
- 2, 2x2x60" (legs)
- 2, 1x2x6 3/4" (braces to keep feet slipping off steps)

Instructions:

1. Measure and mark a square line at 60" on the 2x2 using your marking tools.
2. Clamp this piece to the work bench. Cut on the line. This will be one leg of your stilts. Cut a matching stilt leg, the same length.
3. Clamp a stilt leg to the work bench with a piece of scrap wood under it. Using your tape measure, mark an X at every four inches, starting from one end, until you have marked four Xs.
4. Mark the Xs in the centre of the leg. Use the brace and bit to bore a hole at each X. The scrap wood under the leg protects the work surface when the bit cuts through the leg.
5. Repeat the marking and drilling steps for the other leg.
6. Clamp the 2x4 to the work bench with a C-clamp, with at least 8 inches hanging over the edge.
7. Measure, mark and square the 2x4 at six inches from the end. Clamp and cut it at the six inch line. This will be one step.
8. Repeat to make a matching step.
9. Measure, mark and square a 1x2 piece so it is 6-3/4" long. Clamp and cut it. This piece will keep your foot from sliding off the step.
10. Repeat to make another brace. You will glue a brace to the outside edge of each step.

11. Hammer a finishing nail through the brace and into the step, at either end. Place the nails near the ends so that there will be room to bore holes for the bolts that hold everything together.
12. Repeat step 10 for the other step and brace.
13. Mark where the bolts will go through this way. Place the step/brace piece on the workbench with the brace on the bottom. One edge of the step will face up. Measuring from the end of the step that is even with the brace, mark two marks on the steps edge, at 1" and at 5".
14. Square across the step's edge at each mark. Pencil an X at the centre of each line.
15. Clamp one step/brace piece to the work surface, with a piece of scrap wood underneath. Use a brace and 3/8" bit, drill a hole all the way through both X marks. Hold the brace and bit straight up and down so the hole does not come out the side.
16. Repeat step 13 for the other step/brace.
17. Sand all the pieces well, especially the legs where you will be holding on.
18. Assemble your stilts, making sure that the step/brace piece is right side up! Decide what set of holes to use. Push the bolts through the step/brace until they come out the other side of the leg. Put a washer and wing nut on each bolt and tighten.

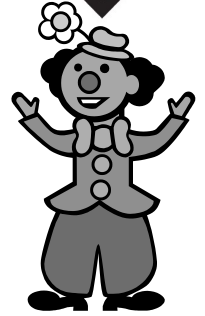

Dig it!

Go back to page 9 and fill in the Learned Column. Attach a picture of you on your stilts below!

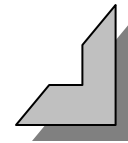
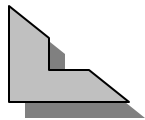
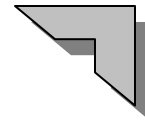
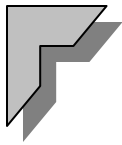

In this picture _____

I want you to notice: _____

What's next?

If you could twist a nail, you would end up with a screw. The next Builder looks at how to use a screw and screwdriver and how to drill pilot holes so that you don't split your piece of wood. You will also build your own tool box.

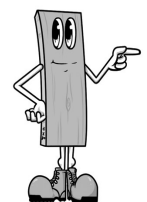

Skill Builder 4: No Screws Loose Here!



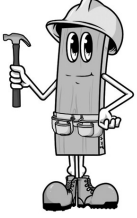

Pip Says....

What's stronger than a nail? A screw! Screws are easily removed from any project. However screws require a special tool called a screwdriver to insert them into the wood. Screws are measured by length (in inches) and the diameter (a gauge number between 0 and 24).

SKILLS CHECKLIST

- Drill pilot holes
- Use a screw drive
- Select the correct screw and screwdriver for the job

Dream it!

Nails With A Twist

When would you want to use a screw instead of a nail? Look around you and find three places where screws are used instead of nails, What do they all have in common?

I found screws in:

- 1.
- 2.
- 3.

I think screws should be used instead of nails ...



Do it!

A Few Screws

The screw is a useful tool as it is used both in construction and finishing. Screws have three parts - the head, the shank, and the spiral threads. Screws hold the wood together by gripping the wood with the threads. Screws come in many different shapes and sizes. In the diagram on the right, 1) is a flathead, 2) is an oval head, 3) is a round head, and 4) is Fillister-head. Thickness of the screw shank ranges from #0 to #12, with #8 being the most common. Three common screwdrivers are the slot or flathead screwdriver, the Phillips or star head screwdriver, and the Robertson or square socket screwdriver. Be careful not to let the screwdriver slip out of the screw or it could damage your piece of wood. Your leader will give you a box of screws. Can you sort them according to their names (flathead, oval head, round head, Fillister-head)? Also take a look at the different types of screwdrivers and try removing a few screws from a piece of wood as well as putting them back in.

Important Words

Watch out for these important words in this builder:

Screw, Screwdriver, Pilot hole, Roundhead, Flathead, Oval, Panhead, Slotted, Phillips, Robertson, Countersink, Rasp



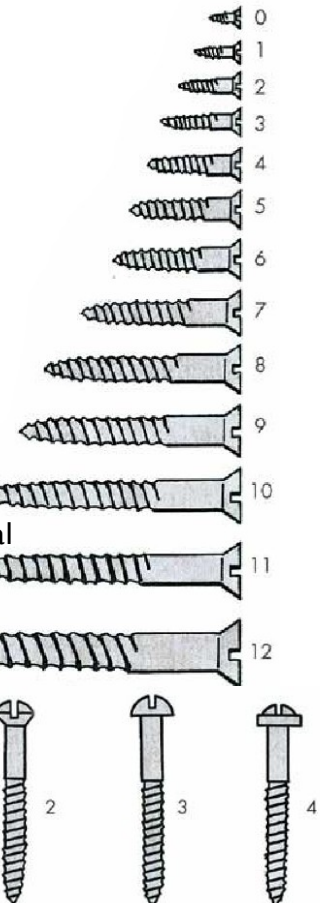

Pilots In Training

Screwing a screw into a piece of wood can sometimes cause the wood to split. To make sure this doesn't happen, a pilot hole is drilled first. You can use the brace and bit or a power drill to make a hole for your screw to start going into. The pilot hole should always be smaller than the size of your screw so that the screw has something to hold onto. Practice drilling your own pilot holes and then screwing in different sized screws.



Toolbox Time

Materials:

- 1 1" x 8" x 18" (Bottom)
- 2 1" x 4" x 18" (Sides)
- 1 1" x 4" x 10" (Ends)
- 1 1" x 6" x 18" (Handle)
- 4 #8, 1/2" flathead wood screws
- 25 #8, 2" flathead wood screws
- fine grit sandpaper

Tools:

- saws
- screwdriver
- round wood rasp or file
- drill with 1" bit
- pilot hole bits to fit screws and countersink

Instructions:

1. Cut pieces to size (see diagram).
2. Mark and cut the angled cuts on the handle, leaving 1/16" or so for sanding.
3. Mark the handle hole. Bore a 1" hole at each end of the mark and saw out the rest. Use the rasp or file to even and round out the edges. Sand and smooth all sides and edges.
4. On the 8 x 18 bottom piece, draw a centre line lengthwise. Mark and drill countersink holes every three inches on this line. Sand smooth all sides and edges. Screw the bottom to the handle with 2" screws.
5. *Tip: When use slotted screws, line up all the slots the same way. It looks more professional.*
6. In the side pieces, drill the countersink holes 3/8" from the bottom edge. Space the holes as shown on the diagram. Sand smooth all sides and edges. Use 2" screws to fasten both sides to the bottom piece.
7. Add the ends in the same way. Use 1/2" screws at the bottom corners so you do not hit the screws holding the side pieces.
8. For extra strength, drill and countersink the holes in each end piece to hold the handle. Use a 2" screw in each hole.
9. In the last builder, you can paint or stain your tool box to personalize it.

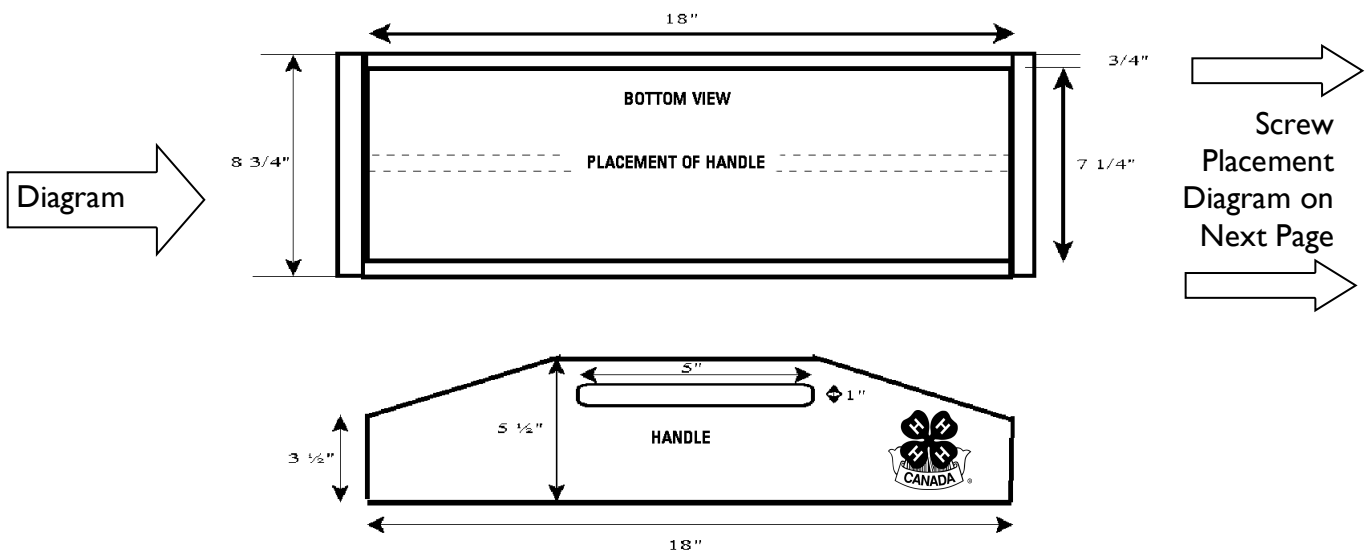

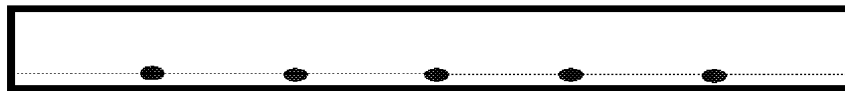

SIDE VIEW SHOWING PLACEMENT OF SCREWS

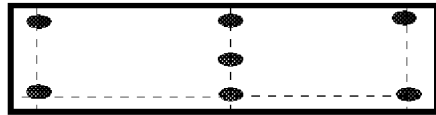

END VIEW SHOWING PLACEMENT OF SCREWS



SCREW PLACEMENT THROUGH BOTTOM INTO HANDLE

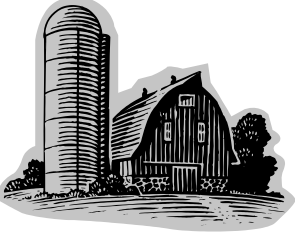

From Farming History...

Most farmers in the past decades had a woodworking shop as they built almost everything out of wood: their houses, furnishings, wagons, fences, barns, tools, and even machinery like harrows and plows.

Think about this builder and the activities you did...

- Review the skills checklist on page 12. What skills have you developed? Do you need more practice?



Does your piece of wood have a dent? You can actually remove this dent by laying a damp cloth over it and heating it with a hot iron until the cloth dries. The process can be repeated as many times as necessary. The hot water opens up the cells of the wood, allowing it to regain it's original form.

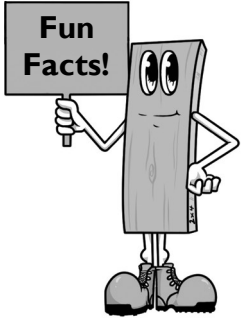

Dig it!

What would you tell someone who was going to make the toolbox you just cut and put together?



Why are pilot holes important?

What's next?

In the next builder, you will compare the strength of glue with that of a nail. You will also learn how to attach two pieces of wood using a hinge. You will get to build a paddle boat that you can float down a river or stream!

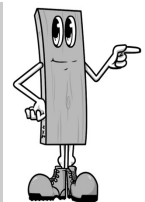

Skill Builder 5: Keep It Together

Pip Says....

Yellow glue, also called carpenter's glue, contains special additives that make it more easily sanded. Yellow glue is especially preferable when working with pine! However, white glue is just as strong as yellow glue.

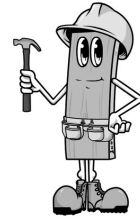

EXPLORE

SKILLS CHECKLIST

- Fasten pieces of wood using a hinge
- Fasten pieces of wood using glue
- Understand the difference between white and yellow glue

Important Words

Watch out for these important words in this builder:
Clamp, Hinge, Glue



Dream it!



The Power In Glue

Your leader will give you two pieces of wood that have been glued together and two pieces that have been nailed together.

I think the _____ will be stronger. The _____ was actually stronger. Warm up your muscles and try and pull them apart. Record what you think will be stronger and what actually is.

Do it!

Two Glues

There are two common kinds of glue used in woodworking. White glue is an all-purpose glue used for most woodworking projects where as yellow glue provides a stronger bond. Be sure to store your glue at room temperature and out of direct sunlight. Whichever glue you choose to use, there are certain steps to follow to make sure your wood stays connected.

Too much glue can result in a thick glue line, and therefore a weaker bond than less glue would have. The ideal moisture content for gluing is 6.8% and high moisture will result in wood movement after gluing. Glues do have a shelf life and will go bad, so check the expiry date.

Fun

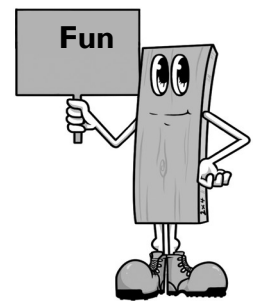

1. Wood must be clean, dry and smooth or it will not glue successfully.
2. Apply a wiggly line of glue to both pieces. Smear the glue around until all the surfaces are covered. If too much glue is used, it will squeeze out, make a mess and go to waste.
3. Put the two glued pieces together and squeeze them. A small amount of glue should squeeze out on the edges. Line them as desired. Clamp them, using wood scraps to prevent dents in the project. Clean up any excess glue.
4. Lightly tighten the clamps at first. Check for positioning.
5. Tighten the clamps further. Leave the clamps on for at least an hour.
6. When the clamps are taken off, leave the project overnight before any more work is done.

Clamping My Style

Try this experiment, using white and yellow glue in steps 1 - 3, to see when glue works best.



1. Glue two dirty or greasy pieces of wood together. Clamp and let dry.
2. Glue two clean pieces of wood together. Clamp and let dry.
3. Glue two pieces of painted wood together. Clamp and let dry.
4. Compare the strength of the examples at the next meeting.

How will these joints stand up over time?

5. Practice gluing pieces of wood together and determining how much glue is enough. Practice cleaning off excess glue with a warm, damp, clean cloth. Maybe later you can practice staining this piece and see how the glue affects the staining process.



6. Compare the types of glues that you have. What differences do you notice in how the glue flows, sticks, smoothes out and bonds?

Circle when glue is stronger:

a)	Dirty Wood	Clean Wood	Painted Wood
b)	After 24 hours	After 1 month	
c)	White Glue	Yellow Glue	

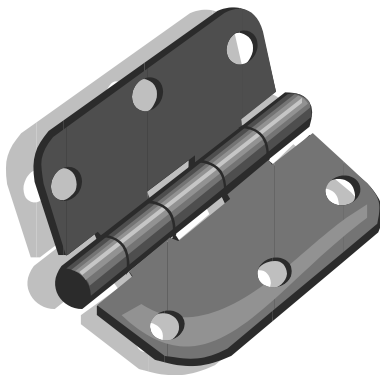

Hinged Lid

In this activity you will design a box of any size and put a lid on it with hinges. Your box can be cubical or a rectangular prism. Before you choose your measurement, consider what you might want to use your box for. How do you want to attach the side and bottom pieces of wood (nails, screws, glue)?

Purpose of My Box:

Materials:

Tools:

Cut List:

Sketch:

Woodn't You Know?

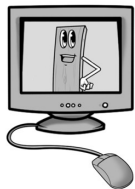

There are many different glues in the stores. To choose the right one for your project, visit http://homenorepair.suite101.com/article.cfm/types_of_woodworking_glue or use a search engine with the words "choose a woodworking glue."

Paddle Boat

Materials:

- 25mm (1") x 153mm (6") x 305mm (12") wood stock for main deck
- 25mm (1") x 103mm (4") x 126mm (5") wood stock for upper cabin
- 6mm (1/4") x 64mm (2 1/2") x 172mm (6 3/4") wood stock for paddles
- 2-19mm (3/4") wood screws
- Elastic band
- Yellow glue (carpenter's glue)
- Acrylic paint or varnish

Tools:

- Pencil
- Coping saw
- Hand saw
- Rasp
- Chisel
- Sandpaper 80-grit and 220-grit
- Paint brush



Instructions:

1. Trace main deck and upper cabin onto wood stock pieces.
2. With rasp slightly taper underside of main deck bow.
3. Sand main deck and cabin pieces until smooth first with rasp and then sandpaper.
4. Glue cabin to main deck.
5. Cut the two paddle blades to size (diagram 3).
6. Cut out notch (notch should only be as thick as wood used) with coping saw and use chisel to chip out waste wood.
7. Slip one notch into the other to form the paddle.
8. Finish boat with a couple of coats of paint or varnish.
9. Screw in the crews to the stern of the main deck.
10. Place elastic band between the paddle blades.
11. Wind up the paddle blades a few times, let it go in the water and enjoy.

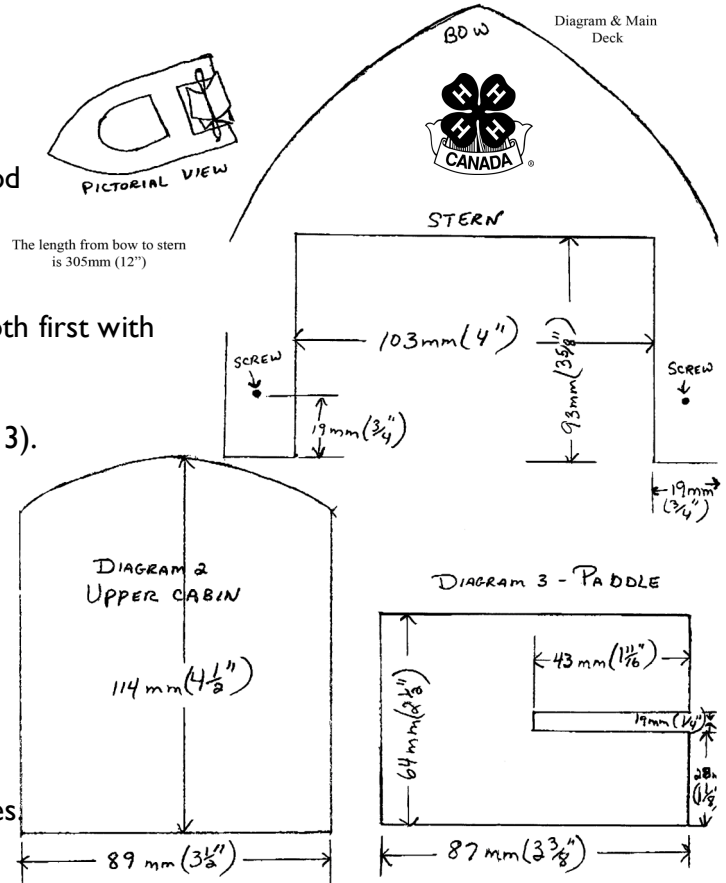

Dig it!

What is the best way to attach two pieces of wood - glue, screws, nails, ...?
Why do you think this is?



What is the best way to avoid leaving clamp marks on a project?

What's next?

The final Builder looks at finishing your projects. Wood products last longer when they have a finish applied to them. This includes sanding it smooth, and applying either coats of varnish or paint. The Tree Trial activity will require some pre-painting.

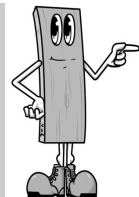

Skill Builder 6: A Strong Finish



Pip Says....

To lengthen your project's life, a finish can be applied. Sanding smooths out the wood so that a level coat of paint or varnish can be put on. Paint and varnish are very flammable so make sure not to use them near an open flame or you will have a fire!



SKILLS CHECKLIST

- Finish projects using basic techniques, including sanding, painting, and varnishing

Dream it!

Final Finish

See if you can find the following words which are all types of finishes.

Important Words

Look out for these important words in this builder:

Sanding, Paint, Varnish, Grit, Grain, Warp

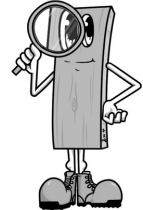
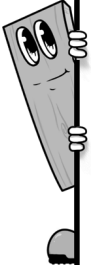
Dragging
 Lacquer
 Oil
 Paint
 Permanent Marker
 Sand
 Shellac
 Splattering
 Sponge
 Stippling
 Rag Rolling
 Varnish

R D E R L F U Q G U W A W V S
 T E G N I R E T T A L P S X T
 D Y K T D Z F P D P L Z A S I
 R V L R L H C A L L E H S A P
 A S L O A I I U V R A P B N P
 G F L R I M L C E S N I G D L
 G X H C W L T U W Z P X H P I
 I H B K M Y Q N B I P O L Y N
 N K A M Q C I C E W H A N Q G
 G C Q B A M A X C N O L I G G
 G N I L L O R G A R A X G N E
 V P R C R V F W P T N M W D T
 V A L P V V A R N I S H R H T
 P D Z L T I S Z X M K Y J E A
 U F Y J M C V L I K O Y D I P

Do it!

Final Touch

Surface finishes include paint, varnish, shellac and lacquer. Paint has colour, whereas the other three are clear and allow the grain to show through. Paint can cover up workmanship errors though.

How to Varnish

1. Prepare the wood finish. It must be clean and smooth. If necessary, fill any holes and cracks. To clean, wipe with mineral spirits.
2. Brush varnish against the grain. Then, brush diagonally. Then, brush with the grain.
3. When completely dry, use fine silicone-carbide paper to smooth the finish.

How to Paint

1. Protect your work surface with newspaper and mix your can of paint.
2. Make sure the object you are painting is clean and free of dirt and grease.
3. Dip only the tip of the brush into the paint (no more than 1/3 of the brush.)
4. Start painting in the corners and work out from there. Paint the flat, easy bits last.
5. Brush the paint with the grain in easy strokes. Keep going until the paint starts to get too thin.

Both varnish and paint will usually require more than one coat, so don't try and put a thick one on.



Wooden Birds

Materials:

- Scrap pieces of pine or other soft wood (3/4" for the body and 1/2" or thinner for the wings)
- Sandpaper
- Finishing materials of your choice (paint, stain, varnish etc.)
- Cleaning supplies
- Small hook

Tools:

- Pencil
- Tracing paper
- Coping saw
- Paint brush
- Hand drill and small bit



Instructions:

1. Place your pattern pieces on the wood, with the arrow running in the same way as the wood grain.
2. Trace your pattern onto the wood.
3. Cut out the wood pieces.
4. Sand carefully.
5. Glue the wings to the bird. Remove any excess glue so it will not interfere with your painting. Let dry.
6. Paint or finish, as you prefer.
7. Carefully insert the small hook into the top of the bird, so it will hang straight.

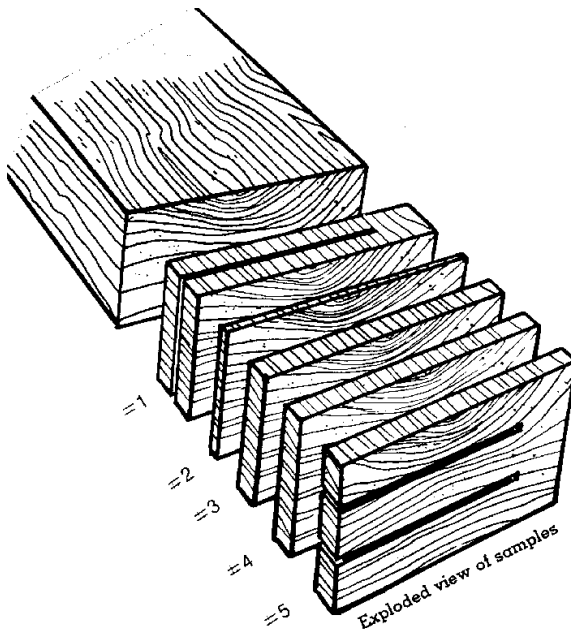
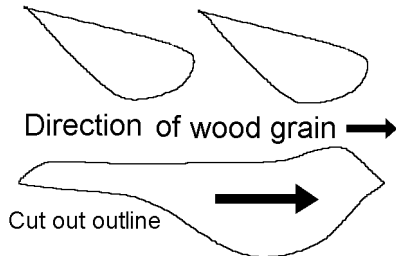
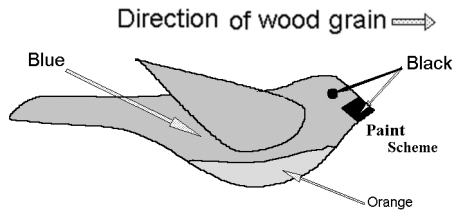
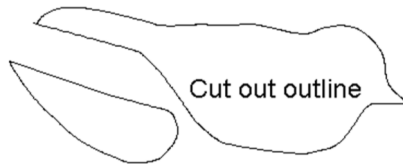
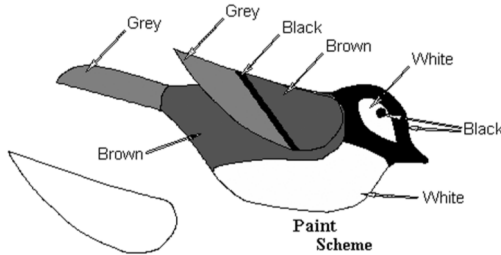

Pip Says...



Sandpaper is measured in grit and the higher the number the finer the grit. You should start with a coarser sand paper and then finish with a finer grit. Always sand with the grain and never cut sandpaper with scissors or else someone will be angry when their scissors are dull. Use an Exacto-Knife instead.

Tree Trial

Cut 5 blocks of wood from a 2 x 4 in the following thicknesses:

- Block #1 – 7/8" thick
- Block #2 – 1/8" thick
- Block #3 – 3/8" thick
- Block #4 – 3/8" thick
- Block #5 – 3/8" thick



- Block #1 – Paint it completely and allow it to dry. (It will take a day or two.) Then make a saw cut across the grain as illustrated, but stop short of cutting the block in two.
- Block #2 – Paint one side and the ends.
- Block #3 – Paint one side and the ends.
- Block #4 – Draw a line lengthwise down the center of the block on both sides. Paint half of one side as illustrated. Turn over and paint ends on that half.
- Block #5 – Make two saw cuts (but stop short of cutting the finger off) then paint the center finger as illustrated.

1. Place all blocks aside to dry. Let them dry thoroughly.
2. Fill a flat, shallow pan (about 2" deep) half full with water.
3. Place the five blocks in the water and leave for 30 minutes or more.
4. Observe what happens to the different blocks.
What happens to each block?

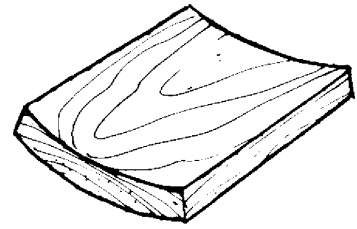

warp

EXPLORE

Which one curved the most? Why?

What caused the blocks to curve?

Which block increased in length?

Are there similarities or differences between block #2 and #3?

After you have completed all the steps above and answered the questions, place the blocks in an oven at 225 degrees for at least 30 minutes. Observe and note what happens.

Dig it!

Now that you know how to finish a woodworking project, choose one from an earlier builder to refinish. Talk with your leader about what the best option is for a finish (paint, varnish, etc...).

I chose to finish _____

by _____.



Thinking about this builder and the activities you did...

Review the skills checklist on page 18. What skills have you developed? Do you need more practice? What skills did you use to make this project a success?



Record it . . .

Discuss what you have learned with your leader



Apply it . . .

How would you explain to others the steps you need to take to have a successful project?

What's next?

Congratulations on completing all six Builders! Now it is time to think about and plan for the Showcase Challenge on page 21 which will help prepare for your 4-H Achievement. On page 23 is your portfolio page where you can make sure all your Exploring Woodworking Project Skills Chart is complete. There will also be space for you to write down some thoughts and reflections on the project (what you liked, didn't like, etc.).

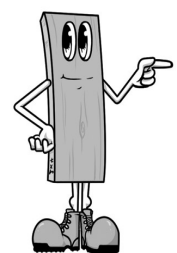

Showcase Challenge

Bringing it all together!

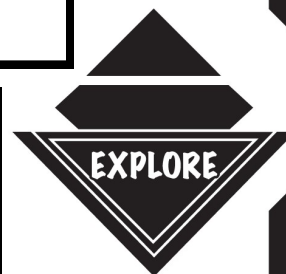

Now that you have finished this project, it is time to think about how you will share your experiences and knowledge with others. You may put your new skills to work by helping at a community event or at your club Achievement or teaching others about your topic. The goal of the Showcase Challenge is to help highlight your new skills and help **you** understand how you can use them. It can be an opportunity to receive feedback from others on your project. So go back through your manual and find some highlights of your learning (what you are proud of) and think about how you will “showcase” it.

Dream It!

Here are some Showcase Challenge Suggestions:

- Demonstrate something you made or learned about
- Make a poster or display
- Make a pamphlet
- Make a computer presentation (e.g. PowerPoint)
- Give a speech
- Create a picture book
- Use your new skills to help with the Club Achievement plans
- Or come up with your own idea. It is up to you and your leader!



My Showcase Challenge Plan



My showcase idea: _____

What materials and resources do I need? _____

Who do I need to help me? _____

When do I need to have things done by? _____



Do It!

Insert or attach your finished product or a photo of you sharing your skills in your Showcase Challenge.

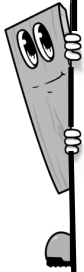

Dig It!

Now that you have showcased your project skills;

- How did your Showcase Challenge go?
- What would you do differently next time?
- How will you use your new skills in the future? (*in different situations?*)





My 4-H Portfolio Page

Manitoba



Name: _____ Date: _____ Year in 4-H: _____

Club: _____ Hours Spent on 4-H: _____ (Project and Other 4-H Activities)



Exploring Woodworking Project Skills Chart

To be completed by the leader and the member based on observations and conversations throughout the project.

Skill Builder	Members will be able to... Each Skill Builder had a Skills Checklist which identified the skill you will learn.	We know this because... Identify activities completed and record observations and information from discussions about activities.
1	<ul style="list-style-type: none"> Understand how practicing safety can prevent injuries Identify the basics of wood processing Recognize the fundamental tools 	
2	<ul style="list-style-type: none"> Learn to follow a pattern Measure and cut wood Understand what units are part of both the metric and imperial systems 	
3	<ul style="list-style-type: none"> Understand the measurement system for nails Select the correct nail and hammer for the job 	
4	<ul style="list-style-type: none"> Drill pilot holes Use a screw drive Select the correct screw and screwdriver for the job 	
5	<ul style="list-style-type: none"> Fasten pieces of wood using a hinge Fasten pieces of wood using glue Understand the difference between white and yellow glue 	
6	<ul style="list-style-type: none"> Finish projects using basic techniques, including sanding, painting, and varnishing 	

Additional Comments/Activities:

Leader Point of Praise!

I am most impressed by...

I acknowledge that the member has completed the 4-H project requirements.

Leader's Signature: _____



Above and Beyond!

In addition to project skills, 4-H also increases skills in meeting management, communications, leadership, community involvement through participation in club, area, or provincial 4-H events or activities. List below any activities you participated in this year in 4-H.

(Some examples include Executive Positions Held, Workshops, Communication, Community Service, Rally, Bonspiels, Conferences, Judging, Camps, Trips, Awards, Representation to Area or Provincial Councils, etc)

_____	_____
_____	_____
_____	_____
_____	_____
_____	_____
_____	_____

**Feel Free to add additional pages that include awards, certificates, new clippings, photos or other items that describe your 4-H involvement.

Member Point of Pride!

What I learned...

What I need to improve on...

What I want others to notice...

Member's Signature: _____



Point of Praise! Another's perspective on your achievements in 4-H.

(community professionals, MAFRI staff, 4-H club head leaders, 4-H Ambassadors, friends of 4-H)

I am most impressed by...

I believe that you have learned...

In the future I encourage you to...

Signature: _____





4-H Achievement

4-H Achievement is... a 4-H club celebration when members have completed their projects. Achievements are planned by the club to give recognition to members and leaders for their accomplishments in their 4-H projects and club activities.



A 4-H Achievement can take many different formats: from choosing a theme, to member project displays, to members using their new skills for the event (entertainment, food, decorating, photographer, etc.), to members presenting their project to the whole group, the options are endless and open to the creativity of the members and leaders in each club!

Clubs may also plan their Achievement to promote 4-H to the community or to recognize sponsors and others who have helped the club.

Members and leaders - be sure to check your project books for the project completion requirements, so you will be ready for your club's Achievement celebration!

If you have any questions, comments or suggestions for this or other 4-H projects contact:

**Manitoba 4-H Projects
Manitoba Agriculture Food and Rural Initiatives
1129 Queens Avenue
Brandon, MB R7A 1L9**

Email: 4h@gov.mb.ca

Phone: 204-726-6613

Fax: 204-726-6260

This manual is for educational use only and is not intended as professional advice.



For more information about 4-H and the many 4-H opportunities available please visit

<http://www.gov.mb.ca/agriculture/4-h/>



What is 4-H?

4-H is an international youth organization involving more than 7 million members in 80 countries around the world.

In Canada, 4-H began in 1913 in Roland, Manitoba as a community-based organization dedicated to growth and development of rural youth. Today's 4-H program reaches both farm and non-farm youth across Canada. The motto of "Learn to Do by Doing" is embodied in the program, as 4-H focuses on skill development as well as personal development of life skills such as communications, leadership and citizenship.

4-H Motto

"Learn To Do by Doing"

4-H Pledge

I pledge,
My HEAD to clearer thinking,
My HEART to greater loyalty,
My HANDS to greater service,
My HEALTH to better living,
For my club, my community, and my country.



4-H Quality Equation Principles

Quality People

- Promote responsibility, respect, trust, honesty, fairness, sportsmanship, citizenship, teamwork and caring.

Quality Experiences

- Provide members with personal development and skill development experiences.

Quality Projects

- Promote and value quality effort.
- Promote high quality, safe food production within industry standards.



Manitoba 4-H project material is developed by
Manitoba Agriculture, Food and Rural Initiatives (MAFRI)

