

400W SERIES INSTALLATION MANUAL

GPS 400W, GNC™ 420W/420AW, and GNS™ 430W/430AW

GNC and GNS are trademarks of Garmin Ltd. or its subsidiaries and may not be used without the express permission of Garmin.



GARMIN®

Garmin International, Inc.

© Copyright 2006-2008
Garmin Ltd. or its subsidiaries
All Rights Reserved

Except as expressly provided herein, no part of this manual may be reproduced, copied, transmitted, disseminated, downloaded or stored in any storage medium, for any purpose without the express prior written consent of Garmin. Garmin hereby grants permission to download a single copy of this manual and of any revision to this manual onto a hard drive or other electronic storage medium to be viewed and to print one copy of this manual or of any revision hereto, provided that such electronic or printed copy of this manual or revision must contain the complete text of this copyright notice and provided further that any unauthorized commercial distribution of this manual or any revision hereto is strictly prohibited.

Garmin International, Inc.
1200 E. 151st Street
Olathe, KS 66062 USA
Telephone: 913-397-8200
Aviation Panel-Mount Technical Support Line (Toll Free): 1-888-606-5482
Web Site Address: www.garmin.com

Garmin (Europe) Ltd.
Liberty House
Bull Copse Road
Hounslow Business Park
Southampton, SO40 9RB, UK
Telephone: 44 (0) 8708501243

RECORD OF REVISIONS

Revision	Revision Date	Description
A	11/2/06	Production Release
B	11/28/06	Added GA 35 antenna information and corrected wire gauge for main connector power.
C	4/5/07	Incorporated customer feedback.
D	10/1/07	Incorporated main software version 3.00 and GPS/WAAS software version 3.0. Added GA 36, GA 37 and several other non-Garmin antennas. Changed GPS antenna cable loss requirements. Added interface interconnects to equipment, including several autopilots, Century AK 1081 GPSS converter, ACK Technologies altitude encoder and Avidyne PFD/MFD. Added GPS vertical guidance display for EFIS 40/50. Added COM remote discrete.
E	3/25/08	Incorporated main software version 3.10 changes. Added ETSO authorizations, ETSO deviations, and FCC ID information. Added interface interconnects to Cessna IFCS and Bendix M4 autopilots, and Collins DME 42. Clarified requirements for approving interfaces to autopilot, audio panel, air data computers and altitude encoders/serializers.
F	10/7/08	Addition of GAD 42, G600, and v3.10 changes
G	12/16/08	Software version 3.20 changes.

CURRENT REVISION DESCRIPTION

<u>Revision</u>	<u>Page Number(s)</u>	<u>Section Number</u>	<u>Description of Change</u>
G	i	TOC	Changed software version from 3.10 to 3.20
	1-18	1.9	Updated contact phone number for Garmin (Europe) Ltd.
	3-12	3.13.1	Corrected formatting of Table 3-7.
	4-13	4.6.1.2	Added note to indicate that additional output settings may be available on unit installed via OEM TC.
	5-4	5.3.1	Added note to indicate that additional output settings may be available on unit installed via OEM TC.
	5-7	5.3.1	Added ADS-B OUT to Channel Outputs table. Also added note [4] to indicate the ADS-B OUT is only available with main software version 3.20 or later.
	5-15	5.3.11	Added table with information for V-Flag State
	5-22	5.3.20	Added note to explain steps that need to be taken to display an alternate traffic color.
	5-41	Checkout Log	Added V-Flag State to Main CDI/OBS Configuration section.
	6-6	6.2	Added 'check GPS Antenna' to the Alert Text 'GPS is not responding' in Table 6-2.
	H-51	Appendix H	Updated Figure H-32 to include note that the ILS/GPS approach discrete is required by some CDIs/HSIs that are used with the M4C/D Autopilots.
	H-55	Appendix H	Updated Figure H-35 to include note that the low level flags or superflags can be connected, but not both.

DOCUMENT PAGINATION

<u>Section</u>	<u>Pagination</u>
Table of Contents	i – viii
Section 1	1-1 through 1-18
Section 2	2-1 through 2-14
Section 3	3-1 through 3-14
Section 4	4-1 through 4-22
Section 5	5-1 through 5-44
Section 6	6-1 through 6-10
Section 7	7-1 through 7-4
Section 8	8-1 through 8-2
Appendix A	A-1 through A-2
Appendix B	B-1 through B-2
Appendix C	C-1 through C-2
Appendix D	D-1 through D-4
Appendix E	E-1 through E-6
Appendix F	F-1 through F-8
Appendix G	G-1 through G-8
Appendix H	H-1 through H-58

This manual reflects the operation of main software version 3.20. Some differences in operation may be observed when comparing the information in this manual to other software versions.

INFORMATION SUBJECT TO EXPORT CONTROL LAWS

This document may contain information which is subject to the Export Administration Regulations ("EAR") issued by the United States Department of Commerce (15 CFR, Chapter VII, Subchapter C) and which may not be exported, released, or disclosed to foreign nationals inside or outside of the United States without first obtaining an export license. A violation of the EAR may be subject to a penalty of up to 10 years imprisonment and a fine of up to \$1,000,000 under Section 2410 of the Export Administration Act of 1979. Include this notice with any reproduced portion of this document.

WARNING



This product, its packaging, and its components contain chemicals known to the State of California to cause cancer, birth defects, or reproductive harm. This Notice is being provided in accordance with California's Proposition 65. If you have any questions or would like additional information, please refer to our web site at www.garmin.com/prop65

Perchlorate Material – special handling may apply, see www.dtsc.ca.gov/hazardouswaste/perchlorate/

WARNING



This product contains a Lithium battery that must be recycled or disposed of properly. Battery replacement and removal must be performed by professional services.



Lamp(s) inside this product contains mercury and must be recycled or disposed of according to local, state, or federal laws.

For more information go to:

www.garmin.com/aboutGarmin/environment/disposal.jsp.

TABLE OF CONTENTS

PARAGRAPH	PAGE
1. GENERAL DESCRIPTION	1-1
1.1 Introduction.....	1-1
1.2 Scope.....	1-2
1.3 Equipment Description	1-2
1.4 Technical Specifications	1-3
1.4.1 Physical Characteristics.....	1-3
1.4.2 General Specifications.....	1-4
1.4.3 GPS Specifications.....	1-5
1.4.4 COM Transceiver Specifications (GNC 420W and GNS 430W Only) **	1-6
1.4.5 VOR Specifications (GNS 430W Only)	1-7
1.4.6 LOC Specifications (GNS 430W Only).....	1-7
1.4.7 Glideslope Specifications (GNS 430W Only)	1-8
1.4.8 GPS Antenna Requirements.....	1-9
1.5 License Requirements.....	1-11
1.6 Regulatory Compliance	1-12
1.6.1 TSO Authorization and Advisory Circular Reference	1-12
1.6.2 TSO Deviations.....	1-14
1.6.3 ETSO Authorization.....	1-15
1.6.4 ETSO Deviations	1-16
1.6.5 FCC Grant of Equipment Authorization	1-16
1.7 Database Options and Updates	1-17
1.7.1 Aviation Database	1-17
1.7.2 Terrain Database	1-17
1.8 Fault Detection and Exclusion (FDE).....	1-17
1.9 Limited Warranty.....	1-18
2. INSTALLATION OVERVIEW	2-1
2.1 Introduction.....	2-1
2.2 Minimum System Configuration	2-1
2.2.1 VFR Installation	2-1
2.2.2 IFR GPS Installation	2-1
2.2.3 IFR VOR/LOC/GS Installation.....	2-2
2.3 External Sensors	2-2
2.3.1 Multiple Uncorrected Pressure Altitude Sources	2-2
2.3.2 Multiple Baro-Corrected Altitude Sources.....	2-2
2.3.3 Multiple Heading Sources.....	2-3
2.4 Antenna Considerations	2-3

2.4.1	GPS Antenna Location.....	2-3
2.4.2	COM Antenna Location.....	2-4
2.4.3	VOR/LOC Antenna Location.....	2-6
2.4.4	Glideslope Antenna Location.....	2-6
2.4.5	Electrical Bonding.....	2-6
2.4.6	Interference of GPS.....	2-6
2.4.7	COM, VOR/LOC, and Glideslope Antenna Installation Instructions.....	2-6
2.5	Mounting Considerations.....	2-7
2.5.1	Determination of Acceptable Field-of-View.....	2-7
2.6	Cabling and Wiring Considerations.....	2-11
2.7	Air Circulation and Cooling.....	2-11
2.8	Compass Safe Distance.....	2-11
2.9	Installation Approval Considerations	2-12
2.9.1	Autopilot Interface Approval	2-12
2.9.2	Altitude Encoder/Air Data Computer Interface Approval	2-12
2.9.3	Audio Panel Interface Approval.....	2-13
3.	INSTALLATION PROCEDURES.....	3-1
3.1	Unit and Accessories.....	3-1
3.2	Optional Accessories	3-2
3.2.1	GPS Antenna Options	3-2
3.2.2	GPS Antenna Doubler.....	3-3
3.2.3	Other Accessories.....	3-3
3.3	Database Options	3-3
3.4	Miscellaneous Options.....	3-3
3.5	Optional Reference Material.....	3-3
3.6	Installation Materials Required but Not Provided	3-4
3.6.1	Optional Accessories Not Supplied (GNC 420W and GNS 430W Only)	3-4
3.6.2	Materials Required But Not Supplied (New Installations Only)	3-4
3.7	Special Tools Required.....	3-5
3.8	Cable Installation	3-6
3.9	Equipment Mounting.....	3-8
3.9.1	Rack Installation.....	3-8
3.9.2	400W Series Unit Insertion and Removal.....	3-8
3.9.3	Unit Replacement.....	3-8
3.10	Antenna Installation and Connection.....	3-9
3.10.1	GPS Antenna.....	3-9
3.10.2	COM Antenna.....	3-10
3.10.3	NAV Antenna	3-10

3.11	Weight and Balance	3-10
3.12	Electrical Load Analysis	3-11
3.13	AFMS Completion – Based on Autopilot Type	3-12
3.13.1	Autopilot Listed in 400W/500W Series AML STC	3-12
3.13.2	Autopilot Not Listed in 400W/500W Series AML STC	3-13
4.	SYSTEM INTERCONNECTS	4-1
4.1	Pin Function List.....	4-1
4.1.1	P4001 Main Connector	4-1
4.1.2	P4002 COM Connector (GNC 420W and GNS 430W Only).....	4-3
4.1.3	P4006 NAV Connector (GNS 430W Only).....	4-4
4.2	Power, Lighting, and Antennas.....	4-5
4.2.1	Power.....	4-5
4.2.2	Lighting Bus.....	4-5
4.2.3	Antennas.....	4-5
4.3	Altitude Gray Code.....	4-6
4.4	Main Indicator.....	4-7
4.4.1	Main Indicator Function.....	4-7
4.4.2	Main Indicator Electrical Characteristics	4-7
4.4.3	Main Indicator Configuration	4-8
4.4.4	Main Indicator Calibration and Checkout.....	4-8
4.4.5	Main Indicator Interconnect.....	4-8
4.5	Annunciators/Switches	4-9
4.5.1	Annunciators/Switches Function.....	4-9
4.5.2	Annunciators/Switches Electrical Characteristics.....	4-11
4.5.3	Annunciators/Switches Configuration	4-11
4.5.4	Annunciators/Switches Calibration and Checkout.....	4-11
4.5.5	Annunciators/Switches Interconnect.....	4-11
4.6	Serial Data.....	4-12
4.6.1	Serial Data Function.....	4-12
4.6.2	Serial Data Electrical Characteristics	4-15
4.6.3	Serial Data Configuration.....	4-15
4.6.4	Serial Data Calibration and Checkout.....	4-15
4.6.5	Serial Data Interconnects	4-15
4.7	COM/VOR/ILS Audio (GNC 420W and GNS 430W only)	4-16
4.7.1	COM/VOR/ILS Audio Function.....	4-16
4.7.2	COM/VOR/ILS Audio Electrical Characteristics	4-16
4.7.3	COM/VOR/ILS Audio Configuration.....	4-17
4.7.4	COM/VOR/ILS Audio Calibration and Checkout.....	4-17

4.7.5	COM/VOR/ILS Audio Interconnect	4-17
4.8	VOR/ILS Indicator (GNS 430W Only)	4-18
4.8.1	VOR/ILS Indicator Function.....	4-18
4.8.2	VOR/ILS Indicator Electrical Characteristics	4-18
4.8.3	VOR/ILS Indicator Configuration	4-19
4.8.4	VOR/ILS Indicator Calibration and Checkout.....	4-19
4.8.5	VOR/ILS Indicator Interconnect.....	4-19
4.9	RMI/OBI.....	4-20
4.9.1	RMI/OBI Function	4-20
4.9.2	RMI/OBI Electrical Characteristics	4-20
4.9.3	RMI/OBI Configuration.....	4-20
4.9.4	RMI/OBI Calibration and Checkout	4-20
4.9.5	RMI/OBI Interconnect	4-20
4.10	DME Tuning (GNS 430W Only).....	4-21
4.10.1	DME Tuning Function.....	4-21
4.10.2	DME Tuning Electrical Characteristics	4-21
4.10.3	DME Tuning Configuration.....	4-22
4.10.4	DME Tuning Calibration and Checkout	4-22
4.10.5	DME Tuning Interconnect References	4-22
5.	POST INSTALLATION CONFIGURATION & CHECKOUT PROCEDURES	5-1
5.1	Mounting and Wiring Check	5-1
5.2	Connector Engagement Check.....	5-1
5.3	Configuration Mode Operations	5-1
5.3.1	MAIN ARINC 429 CONFIG Page	5-2
5.3.2	MAIN RS-232 CONFIG Page	5-5
5.3.3	MAIN SYSTEM CONFIG.....	5-8
5.3.4	MAIN INPUTS 1 Page	5-10
5.3.5	MAIN INPUTS 2 Page	5-10
5.3.6	INSTRUMENT PANEL SELF-TEST Page	5-11
5.3.7	MAIN LIGHTING Page	5-11
5.3.8	GPS DATE/TIME SETUP Page.....	5-12
5.3.9	MAIN DISCRETE INPUTS Page	5-13
5.3.10	MAIN DISCRETE OUTPUTS Page.....	5-13
5.3.11	MAIN CDI/OBS CONFIG Page	5-14
5.3.12	COM SETUP Page (GNC 420W and GNS 430W Only).....	5-16
5.3.13	VOR DISCRETE INPUTS Page (GNS 430W Only).....	5-17
5.3.14	VOR/LOC/GS CDI Page (GNS 430W Only).....	5-17

5.3.15	VOR/LOC/GS ARINC 429 CONFIG Page (GNS 430W Only)	5-19
5.3.16	GPS Vertical Offset	5-20
5.3.17	STORMSCOPE CONFIG Page.....	5-21
5.3.18	STORMSCOPE TEST Page.....	5-21
5.3.19	STORMSCOPE DOWNLOAD DATA Page.....	5-21
5.3.20	TRAFFIC Page	5-22
5.3.21	RYAN TCAD CONFIG Page.....	5-23
5.3.22	GAD 42 CONFIG Page	5-23
5.3.23	GDL CONFIG Page.....	5-23
5.3.24	DATA LINK DIAGNOSTICS Page.....	5-24
5.4	Ground Checks (Configuration Mode)	5-25
5.4.1	Main Indicator (Analog Only)	5-25
5.4.2	VOR/ILS Indicator (GNS 430W Only)	5-25
5.4.3	Discrete Inputs and Annunciator Outputs Checkout.....	5-25
5.4.4	ADC, Altitude Encoder, Fuel Sensor and Fuel/Air Data Computer	5-26
5.4.5	Altitude Encoder (Gray Code Connection).....	5-26
5.4.6	AHRS/IRU Interface Check.....	5-27
5.4.7	GAD 42 Interface Check.....	5-27
5.4.8	Lighting Bus Interface Check	5-27
5.5	Ground Checks (Normal Mode)	5-28
5.5.1	Display of Self-Test Data.....	5-28
5.5.2	Signal Acquisition Check.....	5-29
5.5.3	VHF COM Interference Check	5-29
5.5.4	VHF NAV Checkout (GNS 430W)	5-31
5.5.5	VHF COM Checkout (GNC 420W/GNS 430W).....	5-31
5.5.6	Interface Checkout	5-31
5.5.7	Magnetic Compass Check.....	5-37
5.6	Flight Checks	5-38
5.6.1	GPS Flight Check.....	5-38
5.6.2	VHF COM Flight Check (GNC 420W and GNS 430W).....	5-38
5.6.3	VOR Flight Check (GNS 430W)	5-38
5.6.4	ILS Flight Check (GNS 430W).....	5-39
5.6.5	Autopilot Flight Check.....	5-39
5.7	Database Check.....	5-39
5.7.1	Data Card Replacement.....	5-39
5.8	Airplane Flight Manual Supplement Checks.....	5-40
6.	TROUBLESHOOTING.....	6-1

6.1	Troubleshooting Procedure.....	6-1
6.2	Alert Text Troubleshooting Procedure	6-4
6.3	Contacting the Factory for Assistance	6-9
7.	LIMITATIONS.....	7-1
7.1	Operations.....	7-1
7.1.1	TSO-C146a GPS/WAAS Limitations.....	7-1
7.1.2	Safety Assessment Considerations.....	7-2
7.1.3	Previous Operational Approvals	7-2
7.2	Installation	7-2
7.2.1	GPS Antenna.....	7-2
7.2.2	Antenna Installation – General.....	7-2
7.2.3	Equipment Interfaced to the 400W Series Unit.....	7-2
7.2.4	Preservation of Previous Systems	7-2
7.3	Rotorcraft Installation	7-3
7.4	Aircraft Radio Station License.....	7-3
8.	PERIODIC MAINTENANCE.....	8-1
8.1	Equipment Calibration.....	8-1
8.2	VOR Checks	8-1
8.3	Cleaning.....	8-1
8.4	Battery Replacement.....	8-1
APPENDIX A	ENVIRONMENTAL QUALIFICATION FORM	A-1
APPENDIX B	STC DATA.....	B-1
B.1	STC Information	B-1
B.2	Permission to use STC.....	B-1
B.3	Continued Airworthiness Instructions	B-1
B.4	STC Approved Model List.....	B-1
APPENDIX C	RESERVED	C-1
APPENDIX D	400W SERIES RS-232 AVIATION DATA FORMAT.....	D-1
D.1	Electrical Interface.....	D-1
D.2	General Output Format	D-1
D.3	Output Sentence Type 1.....	D-1
D.4	Output Sentence Type 2.....	D-3
APPENDIX E	400W SERIES RS-232 FUEL/AIR DATA INPUT FORMAT	E-1
E.1	Electrical Interface.....	E-1
E.2	Shadin Altitude Sentence.....	E-1
E.3	Icarus Altitude Sentence	E-1
E.4	Shadin Fuel Flow Sentence.....	E-2
E.5	ARNAV / EI Fuel Flow Sentence.....	E-2
E.6	Shadin Fuel/Air Data Computer Sentence.....	E-3
APPENDIX F	MECHANICAL DRAWINGS	F-1
F.1	Drawing List	F-1

APPENDIX G	APPROVED EQUIPMENT	G-1
G.1	Audio Panels	G-1
G.2	Air Data Computer	G-1
G.3	Altitude Serializer or Fuel/Air Data	G-2
G.4	Autopilots	G-3
G.5	Encoding Altimeter or Blind Encoder (Gray Code)	G-4
G.6	EFIS Displays	G-4
G.7	EHSI	G-4
G.8	IRU/AHRS	G-5
G.9	NAV Indicator	G-5
G.10	Weather, Traffic and Terrain	G-5
G.11	DME	G-6
G.12	CDI/HSI Source Selection Annunciators	G-6
G.13	Multifunction Displays	G-7
G.14	Interface Adapters	G-7
APPENDIX H	STC APPROVED INSTALLATION DIAGRAMS	H-1
H.1	Introduction	H-1
H.2	Drawing List	H-1

LIST OF FIGURES

Figure 2-1. GPS Antenna Installation Considerations	2-5
Figure 2-2. Source Selection Annunciation Field of View	2-9
Figure 2-3. GPS Navigation Annunciation Field of View	2-10
Figure 3-1. Coaxial Cable Installation	3-6
Figure 5-1. MAIN ARINC 429 CONFIG Page	5-2
Figure 5-2. MAIN RS-232 CONFIG Page	5-5
Figure 5-3. MAIN SYSTEM CONFIG Page	5-8
Figure 5-4. MAIN SYSTEM CONFIG Page	5-8
Figure 5-5. MAIN SYSTEM CONFIG Page	5-9
Figure 5-6. MAIN INPUTS 1 Page	5-10
Figure 5-7. MAIN INPUTS 2 Page	5-10
Figure 5-8. INSTRUMENT PANEL SELF-TEST Page	5-11
Figure 5-9. MAIN LIGHTING Page	5-11
Figure 5-10. MAIN LIGHTING Page	5-12
Figure 5-11. DATE/TIME SETUP Page	5-12
Figure 5-12. MAIN DISCRETE INPUTS Page	5-13
Figure 5-13. MAIN DISCRETE OUTPUTS Page	5-13
Figure 5-14. MAIN CDI/OBS CONFIG Page	5-14
Figure 5-15. COM SETUP Page	5-16
Figure 5-16. VOR DISCRETE INPUTS Page	5-17
Figure 5-17. VOR/LOC/GS CDI Page	5-17
Figure 5-18. VOR/LOC/GS ARINC 429 CONFIG Page	5-19
Figure 5-19. Measurement of GPS Vertical Offset	5-20
Figure 5-20. GPS Vertical Offset Page	5-20
Figure 5-21. STORMSCOPE CONFIG Page	5-21
Figure 5-22. STORMSCOPE TEST Page	5-21
Figure 5-23. STORMSCOPE DOWNLOAD DATA Page	5-21
Figure 5-24. TRAFFIC Page (SkyWatch)	5-22
Figure 5-25. TRAFFIC Page (TCAD)	5-22
Figure 5-26. RYAN TCAD CONFIG Page	5-23
Figure 5-27. GAD 42 CONFIG Page	5-23
Figure 5-28. GDL CONFIG Page	5-23
Figure 5-29. Data Link Diagnostics	5-24
Figure F-1. 400W Series Mounting Rack Dimensions	F-3
Figure F-2. GNS 430W Mounting Rack Installation	F-4
Figure F-3. GNC 420W Mounting Rack Installation	F-5
Figure F-4. GPS 400W Mounting Rack Installation	F-6
Figure F-5. 400W Series Recommended Panel Cutout Dimensions	F-7
Figure H-1. 400W Series System Interface Diagram	H-3
Figure H-2. GNS 430W Typical Installation	H-4
Figure H-3. GNC 420W Typical Installation	H-6
Figure H-4. GPS 400W Typical Installation	H-8
Figure H-5. Power, Lighting, and Antenna Interconnect	H-10
Figure H-6. Gray Code Altimeter Interconnect	H-13
Figure H-7. Main Indicator Interconnect	H-14
Figure H-8. KI 209A Main Indicator Interconnect	H-15
Figure H-9. KI 208A Main Indicator Interconnect	H-16
Figure H-10. RS-232 Serial Data Interconnect	H-17
Figure H-11. ARINC 429 EFIS Interconnect	H-19

Figure H-12. ARINC 429 Sandel EHSI Interconnect (One 400W Series Unit, One Sandel SN3308) .	H-21
Figure H-13. ARINC 429 Sandel EHSI Interconnect (Two GNS 430W, One Sandel SN3308).....	H-23
Figure H-14. ARINC 429 Sandel EHSI Interconnect (Two GNS 430W, Two Sandel SN3308).....	H-25
Figure H-15. ARINC 429/RS-232 Air Data/IRU/AHRS Interconnect.....	H-26
Figure H-16. Traffic Advisory System Interconnect	H-28
Figure H-17. GTX 330 Interconnect.....	H-30
Figure H-18. Weather and Terrain Interconnect	H-31
Figure H-19. Audio Panel Interconnect	H-33
Figure H-20. VOR/ILS Indicator Interconnect	H-35
Figure H-21. RMI/OBI Interconnect	H-36
Figure H-22. King Serial Panel DME Tuning Interconnect	H-37
Figure H-23. King Serial Remote DME Tuning Interconnect.....	H-38
Figure H-24. Parallel 2 of 5 DME Tuning Interconnect	H-39
Figure H-25. Bendix/King Analog Autopilot Interconnect	H-40
Figure H-26. Century Autopilot Interconnect.....	H-41
Figure H-27. S-TEC Autopilot Interconnect.....	H-43
Figure H-28. ARINC 429 Sandel EHSI Interconnect (One 400W, One Sandel SN3500)	H-45
Figure H-29. External Navigation Source and GPS Annunciators	H-47
Figure H-30. Parallel Slip Code DME Tuning Interconnect.....	H-49
Figure H-31. Cessna Autopilot Interconnect	H-50
Figure H-32. Bendix Autopilot Interconnect	H-51
Figure H-33. Switches Interconnect.....	H-52
Figure H-34. ARINC 429 Avidyne PFD/MFD Interconnect.....	H-53
Figure H-35. Collins Autopilot Interconnect	H-55
Figure H-36. Garmin GAD 42 Interconnect	H-56
Figure H-37. Garmin G600 Interconnect	H-57

LIST OF TABLES

Table 1-1. 400W Series Units.....	1-1
Table 1-2. Antennas Without IFR GPS Operational Limitations	1-9
Table 1-3. Antennas With IFR GPS Operational Limitations	1-10
Table 1-4. TSO Authorization	1-12
Table 1-5. ETSO Authorization	1-15
Table 3-1. Catalog Part Numbers.....	3-1
Table 3-2. Standard Kit Accessories.....	3-1
Table 3-3. Recommended Crimp Tools (or Equivalent).....	3-5
Table 3-4. Pin Contact Part Numbers	3-7
Table 3-5. Unit Weights.....	3-10
Table 3-6. 400W Series Power Input.....	3-11
Table 3-7. Autopilot Coupling Limitations.....	3-12
Table 5-1. GNS 400W Series Post-Installation Checkout Log.....	5-41
Table 6-1. Troubleshooting Guide.....	6-1
Table 6-2. Alert Text Troubleshooting Guide	6-4
Table A-1. Environmental Qualification Form Part Numbers.....	A-1
Table D-1. Type 1 Output Sentence Format	D-2
Table D-2. Type 2 Output Sentence Format	D-4

400W SERIES HARDWARE MOD LEVEL HISTORY

The following table identifies hardware modification (Mod) Levels for the GPS 400W, GNC 420W and GNS 430W. Mod Levels are listed with the associated service bulletin number, service bulletin date, and the purpose of the modification. The table is current at the time of publication of this manual (see date on front cover) and is subject to change without notice. Authorized Garmin Sales and Service Centers are encouraged to access the most up-to-date bulletin and advisory information on the Garmin Dealer Resource web site at www.garmin.com using their Garmin -provided user name and password.

MOD LEVEL	SERVICE BULLETIN NUMBER	SERVICE BULLETIN DATE	PURPOSE OF MODIFICATION

This page intentionally left blank

1. GENERAL DESCRIPTION

1.1 Introduction

This manual describes the physical, mechanical, and electrical characteristics, as well as instructions and other conditions and limitations for installation and approval of the 400W Series panel-mounted units. The 400W Series includes the GPS 400W, GNC 420W, GNC 420AW, GNS 430W, and GNS 430AW panel-mounted units. Refer to Section 7, Limitations for additional information and other considerations.

NOTE



Except where specifically noted, references made to the GNS 430W will equally apply to the GNS 430AW. Also, except where specifically noted, references made to the GNC 420W will apply equally to GNC 420AW.

Table 1-1. 400W Series Units

MODEL	PART NUMBER	COLOR	NOTES
GPS 400W	011-01057-00	BLACK	
	011-01057-10	GRAY	
	011-01057-40	BLACK	NOTE 1
	011-01057-50	GRAY	NOTE 1
GNC 420W	011-01058-00	BLACK	
	011-01058-10	GRAY	
	011-01058-40	BLACK	NOTE 1
	011-01058-45	BLACK	28 VDC UPGRADE UNIT
	011-01058-50	GRAY	NOTE 1
GNC 420AW	011-01059-00	BLACK	
	011-01059-10	GRAY	
	011-01059-40	BLACK	NOTE 1
	011-01059-50	GRAY	NOTE 1
GNS 430W	011-01060-00	BLACK	
	011-01060-10	GRAY	
	011-01060-40	BLACK	NOTE 1
	011-01060-45	BLACK	28 VDC UPGRADE UNIT
	011-01060-50	GRAY	NOTE 1
GNS 430AW	011-01061-00	BLACK	
	011-01061-10	GRAY	
	011-01061-40	BLACK	NOTE 1
	011-01061-50	GRAY	NOTE 1

Designations: A = 28 VDC Unit with 16w COM transmitter

Note 1: The unit is an upgrade of the non-WAAS unit.

1.2 Scope

The installation instructions and other data contained within this manual are FAA approved under 400W/500W Series AML STC SA01933LA, which is applicable for implementation within airplanes that are type certificated only under Civil Air Regulation 3 (CAR 3) or 14 Code of Federal Regulations (CFR) Part 23. Only the equipment and systems interfaces described in this manual have been determined to be mutually compatible and are operationally suitable and approved for use as characterized herein, or within the FAA approved airplane flight manual supplement (AFMS) reflecting main software version 2.00 and later. Some differences in operation may be observed when comparing the information in this manual and the FAA approved AFMS to later FAA approved software versions. Such differences will be identified in revised editions of the FAA approved AFMS characterizing later software versions, and any applicable limitations and normal or abnormal operating conditions.

It is possible for installers and other appropriately certificated persons to seek FAA approval for installation and operational use of the 400W Series equipment with systems not identified in this manual, such as for aircraft certificated under 14 CFR Parts 25, 27, or 29, by means of a field approval, STC or TC. Refer to FAA Advisory Circular (AC) 20-138A and other applicable guidance when applying for installation and operational approval. AC 21-40 provides guidance for the STC approval process and AC 43-210 provides guidance for the field approval process. If the field approval process is used, it is advisable to consider the conditions and stipulations in FAA Flight Standards Flight Standards Information Bulletin for Airworthiness (FSAW), 94-32, “Guidance for Performing Field Approvals of Installation and Operational Use of Global Positioning Systems (GPS) or GPS with Wide Area Augmentation Systems (GPS/WAAS), Referred to as Global Navigation Satellite Systems (GNSS) Equipment”, as revised.

Regardless of applicability of the AML STC or alternative field approval application for installation and operational approval, prior to completing the installation and before returning the airplane to service, the installer or other appropriately certificated person is required to complete and submit an FAA Form 337 (OMB No. 2120-0020), “Major Repair and Alteration Airframe, Powerplant, Propeller, or Appliance” to their local FAA Flight Standards District Office describing the work accomplished. The FAA Form 337 must detail the equipment and systems to which the respective GPS 400W, GNC 420W, GNC 420AW, GNS 430W, or GNS 430AW is interfaced and reflect appropriately approved or acceptable data for which follow-on FAA field approval is being sought. See AC 43.9-1E for instructions for completing the FAA Form 337.

1.3 Equipment Description

The 400W Series units are 6.25 inches wide 2.66 inches high. The display is a 240 by 128 pixel color LCD. The units include two removable data cards, one with a Jeppesen database (to be inserted in the left card slot), and the second being a terrain database (to be inserted in the right card slot).

The GPS 400W is a GPS/WAAS unit that meets the requirements of Technical Standard Order (TSO)-C146a (specified in Table 1-4) and may be approved for IFR en route, terminal, non-precision, and precision approach operations when installed in reference to the instructions in this manual as referenced in AML STC SA01933LA.

The GNC 420W/(AW) includes all the features of the GPS 400W, and also includes VHF communications transceiver. The “AW” model is a 28 VDC unit with a 16 Watt COM transmitter. The GNC 420W/(AW) meets the requirements of TSOs specified in Table 1-4.

The GNS 430W/(AW) includes all the features of the GNC 420W/(AW), and also includes airborne VOR/localizer (LOC) and glideslope (G/S) receivers. The “AW” model is a 28 VDC unit with a 16 Watt COM transmitter. The GNS 430W/(AW) meets the requirements of TSOs specified in Table 1-4.

CAUTION



The GPS 400W Series product lens is coated with a special anti-reflective coating which is very sensitive to skin oils, waxes and abrasive cleaners. **CLEANERS CONTAINING AMMONIA WILL HARM THE ANTI-REFLECTIVE COATING.** It is very important to clean the lens using a clean, lint-free cloth and an eyeglass lens cleaner that is specified as safe for anti-reflective coatings.

CAUTION



The use of ground-based cellular telephones while aircraft are airborne is prohibited by FCC rules. Due to potential interference with onboard systems, the use of ground-based cell phones while the aircraft is on the ground is subject to FAA regulation 14 CFR §91.21.

FCC regulation 47 CFR §22.925 prohibits airborne operation of ground-based cellular telephones installed in or carried aboard aircraft. Ground-based cellular telephones must not be operated while aircraft are off the ground. When any aircraft leaves the ground, all ground-based cellular telephones on board that aircraft must be turned off. Ground-based cell phones that are on, even in a monitoring state, can disrupt GPS performance.

1.4 Technical Specifications

1.4.1 Physical Characteristics

Bezel Height	2.66 in. (67 mm)
Bezel Width	6.25 in. (159 mm)
Rack Height (Dimple-to-dimple)	2.69 in. (68 mm)
Rack Width	6.32 in. (160 mm)
Depth Behind Panel with Connectors (Measured from face of aircraft panel to rear of connector backshells)	11.00 in. (279 mm)
GPS 400W Weight (Unit only)	4.0 lbs. (1.82 kg)
GPS 400W Weight (Installed with rack and back plate)	5.0 lbs. (2.27 kg)
GNC 420W/AW Weight (Unit only)	4.5 lbs. (2.04 kg)
GNC 420W/AW Weight (Installed with rack and back plate)	5.5 lbs. (2.49 kg)
GNS 430W/AW Weight (Unit only)	5.1 lbs. (2.31 kg)
GNS 430W/AW Weight (Installed with rack and back plate)	6.2 lbs. (2.81 kg)

1.4.2 General Specifications

Operating Temperature Range	-20°C to +55°C. For more details see Environmental Qualification Form on the Dealers Only page on www.garmin.com . See Appendix A for part numbers.
Humidity	95% non-condensing
Altitude Range	-1,500 ft to 50,000 ft
Input Power Requirements	
Input Voltage Range - All Units (Main Connector)	10 to 33.2 VDC
Input Voltage Range GNC 420W, GNS 430W (COM Connector)	11 to 33 VDC
Input Voltage Range GNC 420AW, GNS 430AW (COM Connector)	24.1 to 33 VDC
GPS 400W (Main Connector)	700 mA @ 28 VDC (maximum) 1.4 A @ 14 VDC (maximum)
GNC 420W, GNC 420AW, (Main Connector)	1.2 A @ 28 VDC (maximum) 2.5 A @ 14 VDC (maximum)
GNS 430W, GNS 430AW, (Main Connector)	1.2 A @ 28 VDC (maximum) 2.5 A @ 14 VDC (maximum)
GNC 420W, GNS 430W (COM Connector)	15 mA @ 28 VDC (receive) 3.0 A @ 28 VDC (transmit) 15 mA @ 14 VDC (receive) 6.0 A @ 14 VDC (transmit)
GNC 420AW, GNS 430AW (COM Connector)	15 mA @ 28 VDC (receive) 3.0 A @ 28 VDC (transmit)
Superflag Power Requirements	500 mA maximum per superflag output
Environmental Testing	See Environmental Qualification Form on the Dealers Only page on www.garmin.com . See Appendix A for part numbers.

The display on the 400W Series unit is a sunlight readable LCD display.

Display Size	3.8" diagonal
Active Area	3.29" (W) x 1.75" (H)
Resolution	240 x 128 pixels
Viewing Angle (with a 2:1 contrast ratio, min)	Left/Right: 40° Up: 40° Down: 40°
Viewing Distance	36 inches maximum

1.4.3 GPS Specifications

Number Of Channels	15 (12 GPS and 3 GPS/WAAS/SBAS)
Frequency	1575.42 MHz L1, C/A code
Sensitivity (Acquisition, No Interference)	-134.5 dBm GPS -135.5 dBm WAAS
Sensitivity (Drop Lock)	-144 dBm
Dynamic Range	> 20 dB
Lat/Lon Position Accuracy	<1.25 meter RMS horizontal, <2 meter vertical, with WAAS
Velocity	1000 knots maximum (above 60,000 ft)
TTF (Time To First Fix)	1:45 min. typical with current almanac, position, and time
Reacquisition	10 seconds typical
Position Update Interval	0.2 sec (5 Hz)
1 PPS (Pulse Per Second)	±275 Nsec of UTC second
Datum	WGS-84
SATCOM Compatibility	SATCOM compatibility is dependent upon antenna selection. See Section 1.4.8 for additional information.
Antenna Power Supply	35 mA typical, 40 mA max at 4.7 VDC

1.4.4 COM Transceiver Specifications (GNC 420W and GNS 430W Only) **

Audio Output	100 mW minimum into a 500 Ω load.
Audio Response	Less than 6 dB of variation between 350 and 2500 Hz.
Audio Distortion	The distortion in the receiver audio output shall not exceed 15% at all levels up to 100 mW.
AGC Characteristics	The audio output will not vary by more than 6 dB when the level of the RF input signal, modulated 30% at 1000 Hz, is varied from 5 μ V to 450,000 μ V.
Sensitivity	(S+N)/N on all channels shall be greater than 6 dB when the RF level is 2 μ V (hard) modulated 30% at 1000 Hz at rated audio.
Squelch	2 μ v \pm 6 dB for 25 kHz channels. 3 μ v \pm 6 dB for 8.33 kHz channels.
Selectivity	6 dB BW is greater than \pm 8 kHz for 25 kHz channeling. 60 dB BW is less than \pm 25 kHz for 25 kHz channeling. 6 dB BW is greater than \pm 2.778 kHz for 8.33 kHz channeling. 60 dB BW is less than \pm 7.37 kHz for 8.33 kHz channeling.
Spurious Response	Greater than 85 dB.
Modulation	AM Double sided, Emission Designator 6K00A3E
Frequency Band	118.00 to 136.99 MHz 25 kHz and 8.33 kHz channel spacing
Transmitting Power	GNS 420W, GNS 430W 10 watts minimum, 15 watts maximum GNS 420AW, GNS 430W 16 watts minimum, 20 watts maximum
Transmitter Duty Cycle	Recommended 10% maximum.
Modulation Capability	The modulation is not less than 70% and not greater than 98% with a standard modulator signal applied to the transmitter.
Carrier Noise Level	At least 45 dB (S+N)/N.
Frequency Stability	0.0005%
Demodulated Audio Distortion	Less than 10% distortion when the transmitter is modulated at least 70%.
Sidetone	1.4 VRMS into a 500 Ω load when the transmitter is modulated at least 70%.
Demodulated Audio Response	Less than 6 dB when the audio input frequency is varied from 350 to 2500 Hz.

* C37d Class 4 & 6 may not provide suitable COM transmit range for some high-altitude aircraft.

**Specifications shown apply at nominal input voltages of 13.75 VDC or 27.5 VDC, as applicable, and with a nominal 50 ohm resistive load at the antenna connector.

1.4.5 VOR Specifications (GNS 430W Only)

Receiver Audio Sensitivity	At -103.5 dBm (S+N)/N shall not be less than 6 dB.
Course Deviation Sensitivity	-103.5 dBm or less for 60% of standard deflection.
Flag	The VOR Course Deviation Flag <u>must</u> be flagged: a) in the absence of an RF signal. b) in the absence of the 9960 Hz modulation. c) in the absence of either one of the two 30 Hz modulations. d) When the level of a standard VOR deviation test signal produces less than a 50% of standard deflection.
AGC Characteristics	From -99 dBm to -13 dBm input of a Standard VOR Audio Test Signal, audio output levels shall not vary more than 3 dB.
Spurious Response	Greater than 80 dB.
VOR OBS Bearing Accuracy	The bearing information as presented to the pilot does not have an error in excess of 2.7° as specified by RTCA DO-196 and EuroCAE ED-22B.
Audio Output	A minimum 100 mW into a 500 Ω load.
Audio Response	Less than 6 dB of variation between 350 and 2500 Hz. Except the 1020 Hz Ident Tone is at least 20 dB down in voice mode.
Audio Distortion	The distortion in the receiver audio output does not exceed 10% at all levels up to 100 mW.

1.4.6 LOC Specifications (GNS 430W Only)

Receiver Audio Sensitivity	At -103.5 dBm (S+N)/N shall not be less than 6 dB.
Course Deviation Sensitivity	-103.5 dBm or less for 60% of standard deflection.
Flag	The LOC Course Deviation Flag <u>must</u> be flagged: a) in the absence of an RF signal. b) When either the 90 or 150 Hz modulating signals is removed and the other is maintained at its normal 20%. c) In the absence of both 90 and 150 Hz modulation. d) When the level of a standard localizer deviation test signal produces less than a 50% of standard deflection.
AGC Characteristics	From -86 dBm and -33 dBm input of a Standard VOR Audio Test Signal, audio output levels does not vary more than 3 dB.
Selectivity	Nose Bandwidth: The input signal level required to produce the reference AGC voltage does not vary more than 6 dB over the input signal frequency range of ± 9 kHz from the assigned channel frequency. Skirt Bandwidth: The input signal level required to produce reference AGC voltage will be at least 70 dB greater than the level required to produce reference AGC voltage at the assigned channel frequency at ± 36 kHz from the assigned channel frequency.
Spurious Response	Greater than 80 dB.
Centering Accuracy	Typical 0 ± 3 mV (Max error 9.9 mV per RTCA DO-195).
Audio Output	A minimum 100 mW into a 500 Ω load.
Audio Response	Less than 6 dB of Variation between 350 and 2500 Hz. Except the 1020 Hz Ident Tone is at least 20 dB down in voice mode.
Audio Distortion	The distortion in the receiver audio output does not exceed 10% at all levels up to 100 mW.

1.4.7 Glideslope Specifications (GNS 430W Only)

Sensitivity	-87 dBm or less for 60% of standard deflection.
Centering Accuracy	$0 \pm .0091$ ddm or 0 ± 7.8 mV
Selectivity	The course deviation shall be 0 ddm $\pm .0091$ ddm when using the Glideslope Centering Test Signal as the RF frequency is varied ± 17 kHz from the assigned channel. At frequencies displaced by ± 132 kHz or greater, the input signal is at least 60 dB down.
Standard deflection	a) With a standard deflection 'FLY DOWN' condition (90 Hz dominant), the output shall be -78 mV ± 7.8 mV. b) With a standard deflection 'FLY UP' condition (150 Hz dominant), the output shall be $+78$ mV ± 7.8 mV.
Flag	The unit Flags: a) When the level of a standard deviation test signal produces 50% or less of standard deflection of the deviation indicator. b) In the absence of 150 Hz modulation. c) In the absence of 90 Hz modulation. d) In the absence of both 90 Hz and 150 Hz modulation. e) In the absence of RF.

1.4.8 GPS Antenna Requirements

Antenna performance is critical to the GPS/WAAS operation. The antennas listed in Table 1-2 and Table 1-3 are approved for installation with the 400W Series units with specified limitations. Refer to the following sections and tables for selection of the GPS/WAAS antenna.

1.4.8.1 Antennas Without IFR GPS Operational Limitations

The list of TSO-C144 antennas shown in Table 1-2 allow the 400W Series models to meet TSO-C146a requirements **without** the operational limitations specified in the Limitations Section 7.1.1 of this manual.

Table 1-2. Antennas Without IFR GPS Operational Limitations

Model / Description	Mount Style	Conn Type	Mfr	Part Number	Garmin Order Number	Additional Requirements
GA 35, GPS/WAAS	Screw mount, Teardrop footprint [1]	TNC	Garmin	013-00235-00	013-00235-00	Must have GPS software V3.0 or later.
			Aero Antenna	AT575-93GW-TNCF-000-RG-27-NM	013-00235-00	
GA 36, GPS/WAAS	Screw mount, ARINC 743	TNC	Garmin	013-00244-00	013-00244-00	
			Aero Antenna	AT575-126GW-TNCF-000-RG-27-NM	013-00244-00	
GA 37, GPS/WAAS +XM	Screw mount, ARINC 743	TNC TNC	Garmin	013-00245-00	013-00245-00	
			Aero Antenna	AT2300-126GW-TNCF-000-RG-27-NM	013-00245-00	
Comant , GPS/WAAS+VHF [3]	Screw mount, Teardrop COM	TNC BNC [2]	Comant	CI-2580-200	N/A	
Comant GPS/WAAS +VHF [3]	Screw mount, Teardrop	TNC BNC [2]	Comant	CI-2728-200	N/A	
Comant GPS/WAAS +XM+VHF [3]	Screw mount, Teardrop COM	TNC TNC BNC [4]	Comant	CI-2728-410	N/A	

[1] Same mounting hole pattern as GA 56, but GA 35 antenna has a physically larger footprint.

[2] The GPS/WAAS connector is a TNC type. The VHF connector is a BNC type.

[3] Installation of this antenna is not covered by the Garmin GA Antenna AML STC SA01695SE.

[4] The GPS/WAAS connector is a TNC type. The XM connector is a TNC type. The VHF connector is a BNC type.

1.4.8.2 Antennas With IFR GPS Operational Limitations

The list of TSO-C144 antennas shown in Table 1-3 allow the 400W Series models to meet TSO-C146a requirements **with** the operational limitations specified in the Limitations Section 7.1.1 of this manual.

Table 1-3. Antennas With IFR GPS Operational Limitations

Model / Description	Mount Style	Conn Type	Mfr	Part Number	Garmin Order Number	Additional Requirements
GA 56A, GPS/WAAS Antenna [3]	Screw Mount, ARINC 743 Footprint	BNC	Garmin	011-01154-00	010-10599-00	Operational limitations in Section 7.1.1 of this manual apply.
GA 56W, GPS/WAAS Antenna [3]	Stud Mount, Teardrop Footprint [1]	BNC	Garmin	011-01111-00	010-10561-01	
GA 57, GPS/WAAS and FIS Antenna [3]	Screw Mount, ARINC 743 Footprint	BNC TNC [4]	Garmin	011-01032-00	010-10604-00	
A33, GPS/WAAS Antenna	Screw Mount	TNC	Garmin AT	590-1104	N/A	
			Aero Antenna	AT575-9UW-TNCF-000-05-26-NM	N/A	
A34, GPS/WAAS Antenna	Screw Mount, Teardrop Footprint [2]	TNC	Garmin AT	590-1112	013-00113-00	
			Aero Antenna	AT575-93W-TNCF-000-05-26-NM	013-00113-00	

[1] Same footprint and mounting hole pattern as GA 56.

[2] Same mounting hole pattern as GA 56, but A34 antenna has a physically larger footprint.

[3] Antenna is not compatible with SATCOM. An alternate antenna should be used for installations equipped with SATCOM.

[4] The GPS/WAAS antenna connector is a BNC type. The XM antenna connector is a TNC type.

1.5 License Requirements

The Telecommunications Act of 1996, effective February 8, 1996, provides the FCC discretion to eliminate radio station license requirements for aircraft and ships. The GNC 420W, GNC 420AW, GNS 430W and GNS 430AW installations must comply with current transmitter licensing requirements. In the US, to find out the specific details on whether a particular installation is exempt from licensing, please visit the FCC web site <http://wireless.fcc.gov/aviation>. If an aircraft license is required, make application for a license on FCC form 404, Application for Aircraft Radio Station License. The FCC also has a fax-on-demand service to provide forms by fax. Outside the US, contact the responsible telecommunication authority. The GNC 420W, GNC 420AW, GNS 430W and GNS 430AW owner accepts all responsibility for obtaining the proper licensing before using the transceiver. The maximum transmitting power, modulation identification, and frequency band information may be required for licensing and are detailed in Section 1.4.4.

CAUTION



THE VHF TRANSMITTER IN THIS EQUIPMENT IS GUARANTEED TO MEET FEDERAL COMMUNICATIONS COMMISSION ACCEPTANCE OVER THE OPERATING TEMPERATURE RANGE. MODIFICATIONS NOT EXPRESSLY APPROVED BY GARMIN COULD INVALIDATE THE LICENSE AND MAKE IT UNLAWFUL TO OPERATE THE EQUIPMENT.

1.6 Regulatory Compliance

1.6.1 TSO Authorization and Advisory Circular Reference

The conditions and tests required for TSO approval of this article are minimum performance standards. It is the responsibility of those installing this article either on or within a specific type or class of aircraft to determine that the aircraft installation conditions are within the TSO standards. TSO articles must have separate approval for installation in an aircraft. The article may be installed only in compliance with 14 CFR part 43 or the applicable airworthiness requirements.

For aircraft on the AML for 400W/500W Series STC SA01933LA, the TSO design approval has been determined to be adequate by the STC, which constitutes the separate installation design approval.

Table 1-4. TSO Authorization

Models					Function	TSO	Minimum Performance Standard
GPS 400W	GNC 420W	GNC 420AW	GNS 430W	GNS 430AW			
			•	•	ILS Glideslope	TSO-C34e	RTCA/DO-192
			•	•	ILS Localizer	TSO-C36e	RTCA/DO-195
	•	•	•	•	VHF COM Transmitter 100nm range	TSO-C37d	RTCA/DO-186A Class 4 & 6 for GNC 420W, GNS 430W Class 3 & 5 for GNC 420AW, GNS 430AW
	•	•	•	•	VHF COM Receiver	TSO-C38d	RTCA/DO-186A Class C & E
			•	•	VOR Receiver	TSO-C40c	RTCA/DO-196
•	•	•	•	•	Multipurpose Display	TSO-C113	SAE AS 8034
•	•	•	•	•	GPS WAAS	TSO-C146a	RTCA/DO-229C Class 3

- AC 20-67B, Airborne VHF Communications Equipment Installations
- AC43.13-1B, Acceptable Methods, Techniques and Practices - Aircraft Inspection and Repair
- AC43.13-2A, Acceptable Methods, Techniques and Practices - Aircraft Alterations

System Function	DO-178B Level
Operating System	B
GPS Navigation Information	B
VOR Information	C
LOC/Glideslope Information	C
VHF Communication	C
Display of altitude, heading, course, speed, and track	C
Display of other information - moving map, terrain, flight plan overlay & flight mode, TAS/TIS traffic information, XM Weather data, data from passive lightning detection equipment, checklist & timer	D
Terrain	D

NOTE



Unauthorized changes or modifications to any 400W Series product may void the compliance to required regulations and authorization for continued equipment usage. All 400W Series unit functions are design approved under the TSO. Airworthiness approval for installation and operational use is recognized under AML STC SA01933LA. If additional information (drawing lists and software documentation) is required to substantiate aircraft installation or operational approval, contact Garmin Customer Support for assistance. Garmin does not provide design or certification documentation, including software data, other than to certification authorities.

1.6.2 TSO Deviations

TSO	Deviation
TSO-C34e	1. Garmin was granted a deviation from TSO-C34e to use RTCA/DO-178B minimum software level C instead of RTCA/DO-178A level 2 to demonstrate compliance for the verification and validation of the computer software.
	2. Garmin was granted a deviation from TSO-C34e to use RTCA/DO-160C instead of RTCA/DO-160B as the standard for Environmental Conditions and Test Procedures of Airborne Equipment.
TSO-C36e	1. Garmin was granted a deviation from TSO-C36e to use RTCA/DO-178B minimum software level C instead of RTCA/DO-178A level 2 to demonstrate compliance for the verification and validation of the computer software.
	2. Garmin was granted a deviation from TSO-C36e to use RTCA/DO-160C instead of RTCA/DO-160B as the standard for Environmental Conditions and Test Procedures of Airborne Equipment.
TSO-C37d	1. Garmin was granted a deviation from TSO-C37d to use RTCA/DO-178B instead of RTCA/DO-178A to demonstrate compliance for the verification and validation of the computer software.
	2. Garmin was granted a deviation from TSO-C37d paragraph (a)(1) to allow using RTCA /DO-186A instead of RTCA/DO-186 to specify minimum performance standards.
	3. Garmin was granted a deviation from TSO-C37d to allow a 6dB reduction of transmitter power during the Normal Operating Conditions – Emergency Operation Voltage as described in RTCA/DO-186A paragraph 2.5.13.1 and RTCA/DO-160C paragraph 16.5.2.1.
	4. Garmin was granted a deviation from TSO-C37d paragraph (a)(5) to allow 8.33 kHz channel spacing in addition to the 25 kHz spacing.
	5. Garmin was granted a deviation from TSO-C37d paragraph (b)(1) to allow marking to call our 8.33 kHz channel spacing in addition to the 25 kHz spacing.
TSO-C38d	1. Garmin was granted a deviation from TSO-C38d to use RTCA/DO-178B instead of RTCA/DO-178A to demonstrate compliance for the verification and validation of the computer software.
	2. Garmin was granted a deviation from TSO-C38d paragraph (a)(1) to allow using RTCA /DO-186A instead of RTCA/DO-186 to specify minimum performance standards.
	3. Garmin was granted a deviation from TSO-C38d paragraph (a)(5) to allow 8.33 kHz channel spacing in addition to the 25 kHz spacing.
TSO-C40c	1. Garmin was granted a deviation from TSO-C40c to use RTCA/DO-178B instead of RTCA/DO-178A to demonstrate compliance for the verification and validation of the computer software.
	2. Garmin was granted a deviation from TSO-C40c to use RTCA/DO-160C instead of RTCA/DO-160B as the standard for Environmental Conditions and Test Procedures for Airborne Equipment.
TSO-C113	1. Garmin was granted a deviation from TSO-C113 section 2.1.2 (4) to use RTCA/DO-178B instead of RTCA/DO-178A to demonstrate compliance for the verification and validation of the computer software.
	2. Garmin was granted a deviation from TSO-C113 section 2.1.2 (3) to use RTCA/DO-160D instead of RTCA/DO-160B as the standard for Environmental Conditions and Test Procedures for Airborne Equipment.
TSO-C146a	1. Garmin was granted a deviation from TSO-C146a for the requirement to use as a specific “NAV” labeled key. RTCA/DO-229c Table 2-5 lists the function “Access to primary navigation display (Section 2.2.1.4.1)” with a label “NAV”.
	2. Garmin was granted a deviation from TSO-C146a not to implement RTCA/DO-229C paragraph 2.2.3.2.2 which states “The equipment shall allow the pilot to initiate the missed approach with manual action. It shall be possible to take this action before crossing the MAWP, in which case the equipment shall automatically initiate the missed approach procedure at the MAWP.”
	3. Garmin was granted a deviation from TSO-C146a not to implement RTCA/DO-229C paragraph 2.2.4.2.3 which states “If the aircraft is past the FPAP – (length offset), and the pilot has not already activated the missed approach, the receiver shall automatically transition to missed approach guidance.” This requirement is being eliminated in DO-229D.
	4. Garmin was granted a deviation from TSO-C146a from RTCA/DO-229C paragraphs 2.2.4.6.4 and 2.2.5.6.4 not to use the low altitude alerting function when the 400W series unit has TERRAIN enabled and is not in one of the following states: FAIL, N/A, TEST, or INHIBIT. When TERRAIN is not enabled, or when enabled but the current state is FAIL, N/A, TEST, or INHIBIT, the low altitude alert described in DO-229C 2.2.4.6.4 and 2.2.5.6.4 is used.
	5. Garmin was granted a deviation from TSO-C146a not to implement RTCA/DO-229C paragraph 2.2.1.4.9.c which states “BRG to or from a VOR: The bearing is based on the true-to-magnetic conversion at the waypoint location, using the same magnetic conversion as used to define the path.” Instead, the “user” (current) location will be used. The RTCA/DO-229C paragraph 2.2.1.4.9.c requirement is being eliminated in DO-229D.
	6. Garmin was granted a deviation from TSO-C146a paragraph 4.b. which defines “each separate component that is easily removable (without hand tools), each interchangeable element, and each separate subassembly of the article that the manufacturer determines may be interchangeable must be permanently and legibly marked with at least the name of the manufacturer, manufacturer’s subassembly part number, and the TSO number.”

TSO	Deviation
C146a cont'd	7. Garmin was granted a deviation from TSO-C146a from RTCA/DO-229C paragraphs 2.1.1.10, 2.1.1.7, 2.1.1.8.1, 2.1.1.8.2, 2.1.1.9, 2.1.2.1, 2.1.3.1, 2.1.4.1.4, 2.1.4.1.5 and 2.1.5.1 in the form of an operational limitation to achieve an equivalent level of safety. The operational limitation is based on: <ul style="list-style-type: none"> a. The ability to use antennas that may not meet the minimum gain performance requirements of DO-228. b. The ability to mitigate the effects of the different gain characteristics of those antennas by increasing the effective mask angle through operational limitations. c. The ability to further increase the effective mask angle, through operational limitations, to a level commensurate with test conditions used in the original TSO qualification tests. d. The ability to use -128 dBm as the minimum GPS satellite signal-in-space for the purpose of assessing the operational limitation. e. The ability to use -128 dBm as the minimum SBAS satellite signal-in-space for the purpose of assessing the operational limitation. NOTE 1
	8. Garmin was granted a deviation from TSO-C146a paragraph 2.1.1.9 to use 20 seconds (instead of 10 seconds) to reacquire a dropped satellite under the conditions described in the paragraph. The 20 second period is the time period specified by the newer DO-229D. NOTE 1

Note 1: No. 7 deviation is applicable with GPS software version 2.X or installations with an antenna listed in section 1.4.8.2.No. 8 deviation is applicable with GPS software version 3.0 or newer.

1.6.3 ETSO Authorization

Table 1-5. ETSO Authorization

Models					Function	ETSO	Minimum Performance Standard
GPS 400W	GNC 420W	GNC 420AW	GNS 430W	GNS 430AW			
			•	•	ILS Glideslope	ETSO-2C34f	EUROCAE ED-47B
			•	•	ILS Localizer	ETSO-2C36f	EUROCAE ED-46B
	•	•	•	•	VHF COM Transmitter	ETSO-2C37e	EUROCAE ED-23B Class 4 & 6 for GNC 420W, GNS 430W Class 3 & 5 for GNC 420AW, GNS 430AW
	•	•	•	•	VHF COM Receiver	ETSO-2C38e	EUROCAE ED-23B Class C & E
			•	•	VOR Receiver	ETSO-2C40c	EUROCAE ED-22B
•	•	•	•	•	Multipurpose Display	ETSO-C113	SAE AS 8034
•	•	•	•	•	GPS WAAS	ETSO-C146	RTCA/DO-229C Class 3

1.6.4 ETSO Deviations

The GNS 400W Series meets the requirements of the listed ETSOs with the following deviations.

ETSO	Deviation
ETSO-2C34f	Garmin was granted a deviation from ETSO-2C34f to use RTCA/DO-160C instead of RTCA/DO-160D.
ETSO-2C36f	Garmin was granted a deviation from ETSO-2C36f to use RTCA/DO-160C instead of RTCA/DO-160D.
ETSO-2C37e	Garmin was granted a deviation from ETSO-2C37e to use RTCA/DO-160C instead of RTCA/DO-160D.
ETSO-2C38e	Garmin was granted a deviation from ETSO-2C38e to use RTCA/DO-160C instead of RTCA/DO-160D.
ETSO-2C40c	Garmin was granted a deviation from ETSO-2C40c to use RTCA/DO-160C instead of RTCA/DO-160D.
ETSO-C113	Garmin was granted a deviation from ETSO-C113 to use RTCA/DO-160C instead of RTCA/DO-160D.
ETSO-C146	<ol style="list-style-type: none"> 1. Garmin was granted a deviation from ETSO-C146 to use RTCA/DO-160C instead of RTCA/DO-160D. 2. Garmin was granted a deviation from ETSO-C146 to use RTCA/DO-229C instead of RTCA/DO-229B for minimum operating specifications. 3. Garmin was granted a deviation from RTCA/DO-229C for the requirement to use as a specific “NAV” labeled key. RTCA/DO-229C Table 2-5 lists the function “Access to primary navigation display (Section 2.2.1.4.1)” with a label “NAV”. 4. Garmin was granted a deviation from RTCA/DO-229C not to implement paragraph 2.2.3.2.2 which states “The equipment shall allow the pilot to initiate the missed approach with manual action. It shall be possible to take this action before crossing the MAWP (Missed Approach Waypoint), in which case the equipment shall automatically initiate the missed approach procedure at the MAWP.” 5. Garmin was granted a deviation from RTCA/DO-229C not to implement paragraph 2.2.4.2.3 which states “If the aircraft is past the FPAP – (length offset), and the pilot has not already activated the missed approach, the receiver shall automatically transition to missed approach guidance.” 6. Garmin was granted a deviation from RTCA/DO-229C paragraphs 2.2.4.6.4 and 2.2.5.6.4 not to use the low altitude alerting function when the GNS 400W Series unit has TERRAIN enabled and is not in one of the following states: FAIL, N/A, TEST, or INHIBIT. When TERRAIN is not enabled, or when it is enabled but the current state is FAIL, N/A, TEST, or INHIBIT, the low altitude alert described in DO-229C 2.2.4.6.4 and 2.2.5.6.4 is used. 7. Garmin was granted a deviation from RTCA/DO-229C not to implement paragraph 2.2.1.4.9.c which states “BRG to or from a VOR: The bearing is based on the true-to-magnetic conversion at the waypoint location, using the same magnetic conversion as used to define the path.” Instead, the “user” (current) location will be used. 8. Garmin was granted a deviation from RTCA/DO-229C paragraph 2.1.1.9 to allow the unit up to 20 seconds (instead of 10 seconds) to reacquire a dropped satellite under the conditions described in the paragraph.

1.6.5 FCC Grant of Equipment Authorization

Model	FCC ID
GNC 420W, GNS 430W	IPH-0021400 (VHF COM Transceiver)
GNC 420AW, GNS 430AW	IPH-0061100 (VHF)

1.7 Database Options and Updates

1.7.1 Aviation Database

The aviation database resides on a database card that is inserted in the left card slot on the unit front panel.

The database is generated on periodic cycles from current Jeppesen data and converted to the format used by the 400W Series unit products. The data conversion process is performed using software that is developed and maintained under Garmin document control processes according to RTCA/DO-200A, Standards for Processing Aeronautical Data.

The database can be updated by purchasing a database subscription from Jeppesen. The database updates include either replacing or re-programming the database card and inserting the updated card in the left card slot on the unit front panel. Contact Jeppesen at 800-621-5377 or www.jeppesen.com for more information and instructions.

Contact Garmin for more information on databases available for the 400W Series unit.

1.7.2 Terrain Database

The Terrain database resides on a database card that is inserted in the right card slot on the unit front panel.

The Terrain database, which serves the standard configured 400W Series unit providing Terrain functionality, is available for updating on periodic cycles and is available from Garmin. Terrain database updates can be accomplished by replacing or reprogramming the database card and inserting the updated card in the right card slot on the unit front panel. The Terrain database can be downloaded via the internet and the card programmed using a USB programmer available from Garmin. Contact Garmin at 800-800-1020 or www.garmin.com for more information or instructions.

1.8 Fault Detection and Exclusion (FDE)

The 400W Series unit, when installed as defined in this manual, complies with the requirements for GPS primary means navigation in oceanic and remote airspace when used in conjunction with the FDE Prediction program included with the GNS 400W/500W Series Trainer CD.

The 400W Series unit includes fault detection and exclusion (FDE), which is active for all flight phases including oceanic and remote operations, en route and terminal, and precision and non-precision approaches, and does not require any pilot interaction. The FDE consists of two parts:

1. The fault detection function detects a satellite failure that can affect navigation; and
2. The exclusion function is the capability to exclude one or more failed satellites and prevent them from affecting navigation.

The FDE Prediction program, included with the GNS 400W/500W Series Trainer CD, is used to predict FDE availability. The FDE Prediction program must be used prior to oceanic or remote area flights for all operators using the 400W Series unit as primary means navigation under FAR parts 91, 121, 125, and 135.

1.9 Limited Warranty

This Garmin product is warranted to be free from defects in materials or workmanship for two years from the date of purchase. For WAAS upgrade of this product, the warranty is separate and described in the service record or statement.

Products bought through online auctions are not eligible for rebates or other special offers from Garmin. Online auction confirmations are not acceptable for warranty verification. To obtain warranty service, an original or copy of the sales receipt from the original retailer is required. Garmin will not replace missing components from any package purchased through an online auction.

Within a warranty period, Garmin will, at its sole option, repair or replace any components that fail in normal use. Such repairs or replacement will be made at no charge to the customer for parts or labor, provided that the customer is responsible for any transportation cost. This warranty does not cover failures due to abuse, misuse, accident or unauthorized alteration or repairs. SUCH REMEDY SHALL BE YOUR SOLE AND EXCLUSIVE REMEDY FOR ANY BREACH OF WARRANTY

THE WARRANTIES AND REMEDIES CONTAINED HEREIN ARE EXCLUSIVE AND IN LIEU OF ALL OTHER WARRANTIES EXPRESS OR IMPLIED OR STATUTORY, INCLUDING ANY LIABILITY ARISING UNDER ANY WARRANTY OF MERCHANTABILITY OR FITNESS FOR A PARTICULAR PURPOSE, STATUTORY OR OTHERWISE. THIS WARRANTY GIVES YOU SPECIFIC LEGAL RIGHTS, WHICH MAY VARY FROM STATE TO STATE.

IN NO EVENT SHALL GARMIN BE LIABLE FOR ANY INCIDENTAL, SPECIAL, INDIRECT OR CONSEQUENTIAL DAMAGES, WHETHER RESULTING FROM THE USE, MISUSE, OR INABILITY TO USE THIS PRODUCT OR FROM DEFECTS IN THE PRODUCT. Some states do not allow the exclusion of incidental or consequential damages, so the above limitations may not apply to you.

To obtain warranty service, contact your local Garmin Authorized Service Center. For assistance in locating a Service Center near you, call Garmin Customer Service at one of the numbers shown below.

Garmin International, Inc.
1200 East 151st Street
Olathe, Kansas 66062, U.S.A.
Phone: 913/397.8200
FAX: 913/397.0836

Garmin (Europe) Ltd.
Liberty House
Bull Copse Road
Hounslow Business Park
Southampton, SO40 9RB, UK
Telephone: 44(0) 8708501243

2. INSTALLATION OVERVIEW

2.1 Introduction

Always follow acceptable avionics installation practices per AC 43.13-1B, AC 43.13-2A, or later FAA approved revisions of these documents. The GPS/WAAS installation instructions have been prepared to meet the guidance material contained in AC 20-138A “Airworthiness Approval of Global Navigation Satellite System (GNSS) Equipment”. The communications installation instructions have been prepared to meet the guidance material defined by AC 20-67B, “Airborne VHF Communications Equipment Installations”. Follow the installation procedure in this section, as it is presented, to accomplish a successful installation. Read the entire section before beginning the work.

Prior to installation, consider the structural integrity of the 400W Series installation as defined in AC 43.13-2A, Chapter 1. Complete an electrical load analysis in accordance with AC 43.13-1B, Chapter 11, on the aircraft prior to starting modification to ensure aircraft has the ability to carry the 400W Series load. Refer to Section 3.12 to calculate the total power consumption of each 400W Series mode of operation. Document the results of the electrical load analysis on the FAA Form 337.

Once the installation is complete, perform the post installation checkout before closing the work area in case problems occur.

2.2 Minimum System Configuration

2.2.1 VFR Installation

The minimum 400W Series unit installation requires the following items for a VFR Installation:

- GNS 400W Series unit (installed in the aircraft manufacturer approved location for 6.25 inch wide avionics equipment).
- GPS antenna is required for GPS navigation functions.
- An external CDI is required for installations using VOR navigation and glideslope information.
- A NAV antenna is required for VHF NAV functions.
- A COM antenna is required for COM functions.

VFR installations must be placarded “GPS LIMITED TO VFR USE ONLY” in clear view of the pilot.

2.2.2 IFR GPS Installation

In order for the 400W Series unit to be utilized for IFR GPS Navigation, the criteria in Section 2.2.1 must be met in addition to the following:

- An External CDI/HSI indicator must be installed in the pilot’s primary field-of-view (or in the aircraft manufacturer approved mounting location). The indicator must have a vertical deviation indicator (GS) in order to perform VNAV operations / approaches.
- Any annunciation required for Source Selection or IFR GPS Navigation must meet the acceptable field-of-view requirements as noted in Section 2.5.1.

NOTE



To take full advantage of the 400W Series unit capabilities, an optional barometric altitude source is recommended for automatic sequencing of fix-to-altitude (FA) and hold-to-altitude (HA) leg types. If no barometric altitude data is provided to the 400W Series unit, FA and HA legs must be manually sequenced.

2.2.3 IFR VOR/LOC/GS Installation

The minimum GNS 430W installation requires the following items for an IFR VOR/LOC/GS Installation:

- GNS 430W (installed in the aircraft manufacturer approved location)
- GPS antenna, VOR/LOC antenna, glideslope antenna, and COM antenna.
- An External CDI/HSI indicator must be installed in the pilot's primary field-of-view (or in the aircraft manufacturer approved mounting location). The indicator must have a vertical deviation indicator for glideslope and VNAV operations/approaches.
- Any annunciation required for Source Selection or IFR GPS Navigation must meet the acceptable field-of-view requirements as noted in Section 2.5.1.

2.3 External Sensors

When the 400W Series unit is installed with external sensors, these sensors must be installed in accordance with the manufacturer's data. This manual does not provide information for the installation of specific external sensors.

The 400W Series unit can accept data from multiple altitude, heading, and baro correction sources. If multiple sources are used, the 400W Series unit will accept data as described below.

NOTE



Barometric altitude is not required by the 400W Series unit to meet the requirements of TSO C146a.

2.3.1 Multiple Uncorrected Pressure Altitude Sources

The 400W Series can accept altitude from a Gray code or RS-232 altitude encoder, fuel/air data computer (FADC), ARINC 429 air data computer (ADC), ARINC 429 EFIS, and ARINC 429 traffic advisory system.

If multiple sources of altitude data are supplied to the 400W Series unit, only valid data from the highest priority source is used (input priority cannot be configured). If the highest priority source becomes unavailable, data is taken from the next-highest priority source. The priorities of the altitude sources are as follows (from highest to lowest):

1. ARINC 429 ADC
2. ARINC 429 EFIS
3. ARINC 429 traffic advisory system
4. RS-232 FADC
5. RS-232 Altitude Encoder
6. Parallel Altitude Encoder (Gray code)

2.3.2 Multiple Baro-Corrected Altitude Sources

The 400W Series can accept baro-corrected altitude from an ARINC 429 ADC, ARINC 429 EFIS, RS-232 FADC, and GTX 33/330 transponder.

If multiple sources of baro-corrected altitude data are supplied to the 400W Series unit, only valid data from the highest priority source is used. If the highest priority source becomes unavailable, data is taken from the next-highest priority source. The priorities of the baro-corrected altitude sources are as follows (from highest to lowest):

1. ARINC 429 ADC
2. ARINC 429 EFIS

-
3. ARINC 429 from GTX 33/330
 4. RS-232 FADC

2.3.3 Multiple Heading Sources

The 400W Series can accept heading data from an ARINC 429 INS/IRU, ARINC 429 EFIS, GAD 42, EHSI, GTX 33/330 transponder, ARINC 429 traffic advisory system, RS-232 FADC, and RS-232 WX-500 Stormscope®.

If multiple sources of heading data are supplied to the 400W Series unit, only valid data from the highest priority source is used – preference is given to true heading (ARINC 429 label 314) if both true heading (label 314) and magnetic heading (label 320) are received. If the highest priority source becomes unavailable, data is taken from the next-highest priority source. The priorities of the heading sources are as follows (from highest to lowest):

1. ARINC 429 INS/IRU
2. ARINC 429 EFIS
3. ARINC 429 from GAD 42
4. ARINC 429 from Sandel EHSI
5. ARINC 429 from GTX 33/330
6. ARINC 429 traffic advisory system
7. RS-232 FADC
8. RS-232 WX-500 Stormscope

2.4 Antenna Considerations

This section contains mounting location considerations for the antennas required for the 400W Series units.

The GPS 400W requires a GPS/WAAS antenna, the GNC 420W/420AW requires a GPS/WAAS and COM antenna, and the GNS 430W and GNS 430AW require four antennas: a GPS/WAAS antenna, a COM antenna, a NAV antenna, and a Glideslope antenna. Structural substantiation for mounting of antennas is beyond the scope of the 400W Series unit STC. For mounting the GPS/WAAS antenna, refer to Garmin GA Antenna AML STC SA01695SE or other FAA approved data. For mounting the COM, NAV, and Glideslope antennas, refer to the aircraft manufacturer's data.

2.4.1 GPS Antenna Location

The GPS antenna is a key element in the overall system performance and integrity for a GPS/WAAS navigation system. The mounting location, geometry, and surroundings of the antenna can affect the system performance and/or availability. The following guidance provides information to aid the installer in ensuring that the most optimum location is selected for the installation of the GPS antenna. The installation guidelines presented here meet the intent of AC 20-138A section 16. The greater the variance from these guidelines, the greater the chance of decreased availability. Approach procedures with vertical guidance are the most sensitive to these effects. LNAV only approaches, terminal operations, and enroute operations may also be affected. Because meeting all of these installations guidelines may not be possible on all aircraft, these guidelines are listed in order of importance to achieve optimum performance. Items 3 below are of equal importance and their significance may depend on the aircraft installation. The installer should use their best judgment to balance the installation guidelines.

1. Mount the antenna as close to level as possible with respect to the normal cruise flight attitude of the aircraft. If the normal flight attitude is not known, substitute the waterline, which is typically referenced as level while performing a weight and balance check.

-
2. The GPS antenna should be mounted in a location to minimize the effects of airframe shadowing during typical maneuvers. Typically mounting farther away from the tail section reduces signal blockage seen by the GPS antenna.
 - 3a. The GPS antenna should be mounted no closer than two feet from any VHF COM antenna or any other antenna which may emit harmonic interference at the L1 frequency of 1575.42 MHz. An aircraft EMC check (reference VHF COM interference check in Post Installation Checkout procedures) can verify the degradation of GPS in the presence of interference signals. If an EMC check reveals unacceptable interference, insert a GPS notch filter in line with the offending VHF COM or the (re-radiating) ELT transmitter.

Note: When mounting a combination antenna (ex. GPS and COM, GPS and XM), the recommended distance of two feet or more is not applicable to the distance between the antenna elements provided the combination antenna is TSO authorized and has been tested to meet Garmin's minimum performance standards.
 - 3b. The GPS antenna should be mounted no closer than two feet from any antennas emitting more than 25 watts of power. An aircraft EMC check can verify the degradation of GPS in the presence of interference signals.
 - 3c. To minimize the effects of shadowing at 5° elevation angles, the GPS antenna should be mounted no closer than 6 inches (edge to edge) from other antennas, including passive antennas such as another GPS antenna or XM antenna.
 4. To maintain a constant gain pattern and limit degradation by the windscreen, avoid mounting the antenna closer than 3 inches from the windscreen.
 5. For multiple GPS installations, the antennas should not be mounted in a straight line from the front to the rear of the fuselage. Also varying the mounting location will help minimize any aircraft shading by the wings or tail section (in a particular azimuth, when one antenna is blocked the other antenna may have a clear view).

Figure 2-1 shows the recommended placement of antennas.

2.4.2 COM Antenna Location

The GNC 420W/GNS 430W COM antenna should be well removed from all projections, engines and propellers. The ground plane surface directly below the antenna should be a flat plane over as large an area as possible (18 inches square, minimum). The antenna should be mounted a minimum of six feet from any DME or other COM antennas, four feet from any ADF sense antennas, and two feet from the 400W Series and its GPS antenna. The COM antenna should also be mounted as far apart as practical from the ELT antenna. Some ELTs have exhibited re-radiation problems generating harmonics that may interfere with GPS signals. This can happen when the COM (400W Series or any other COM) is transmitting on certain frequencies such as 121.15 or 121.175 MHz, which may cause the ELT output circuit to oscillate from the signal coming in on the ELT antenna coax.

If simultaneous use of two COM transceivers is desired (Split-COM or simul-comm), use of the TX interlock function is mandatory. In addition, the COM antennas should be spaced for maximum isolation. A configuration of one topside antenna and one bottom side antenna is recommended.

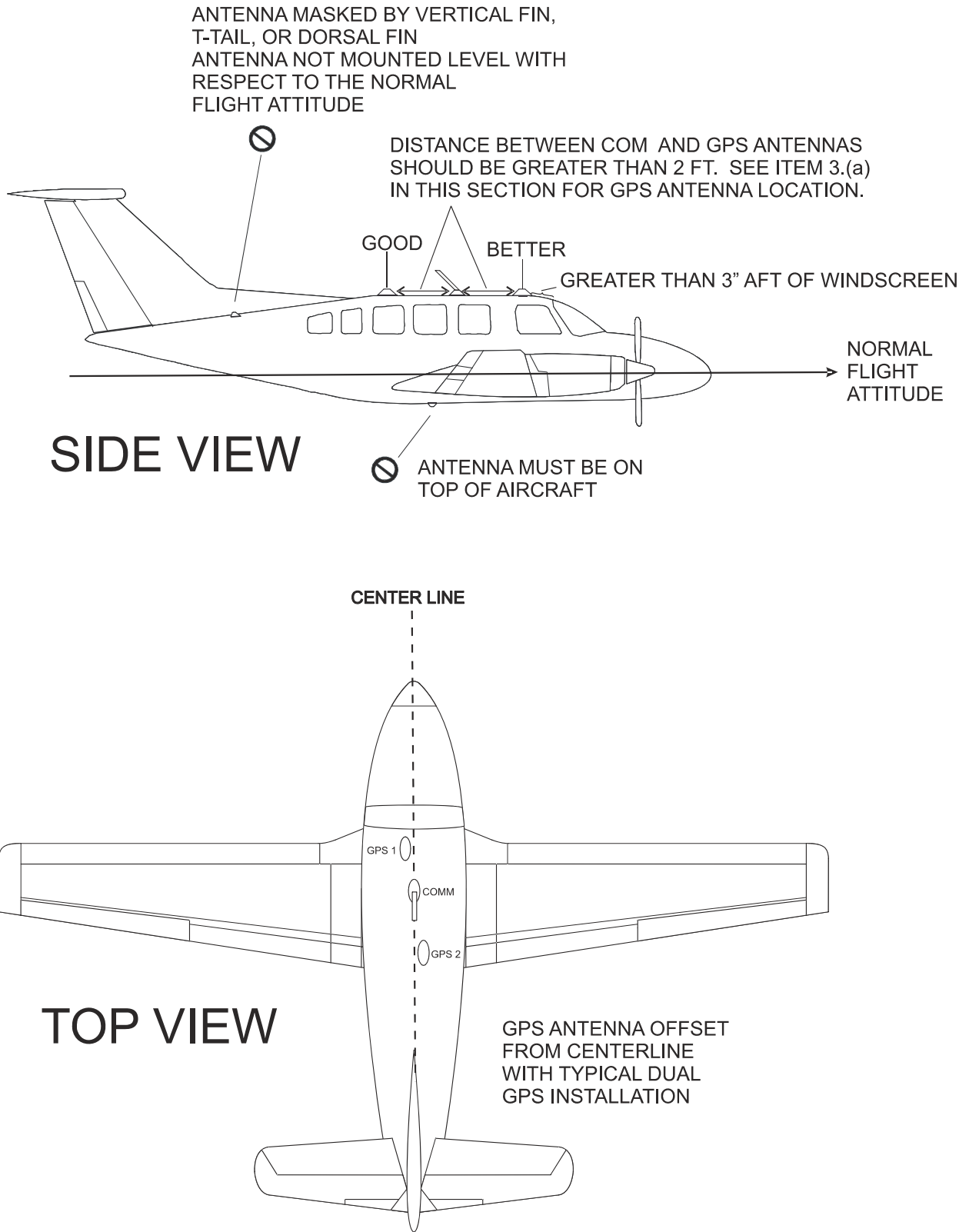

Figure 2-1. GPS Antenna Installation Considerations

2.4.3 VOR/LOC Antenna Location

The GNS 430W VOR/LOC antenna should be well removed from all projections, engines and propellers. It should have a clear line of sight if possible. The antenna must be mounted along the centerline of the aircraft, minimizing the lateral offset.

2.4.4 Glideslope Antenna Location

The GNS 430W Glideslope antenna should be well removed from all projections, engines and propellers. It should have a clear line of sight if possible.

2.4.5 Electrical Bonding

No special precautions need to be taken to provide a bonding path between the GPS antenna and the aircraft structure. Follow the manufacturers' instructions for the COM, VOR/LOC and Glideslope antennas.

2.4.6 Interference of GPS

On some installations, VHF COM transceivers, Emergency Locator Transmitter (ELT) antennas, and Direction Finder (DF) receiver antennas can re-radiate through the GPS antenna. The 400W Series COM does not interfere with its own GPS section. However, placement of the GPS antenna relative to a COM transceiver and COM antenna (including the GNC 420W or GNS 430W COM antenna), ELT antenna, and DF receiver antenna is critical.

Use the following guidelines, in addition to others in this document, when locating the 400W Series unit and its antennas.

- GPS Antenna—Locate as far as possible from all COM antennas and all COM transceivers (including the 400W Series COM), ELT antennas, and DF receiver antennas. The GPS antenna is less susceptible to harmonic interference if a 1.57542 GHz notch filter is installed on the COM transceiver antenna output.
- Locate the 400W Series unit as far as possible from all COM antennas.

If a COM antenna is found to be the problem, a 1.57542 GHz notch filter (Garmin P/N 330-00067-00) may be installed in the VHF COM coax, as close to the COM as possible. This filter is not required for the GNC 420W and GNS 430W transmitters.

If a COM is found to be radiating, the following can be done:

1. Replace or clean the VHF COM rack connector to ensure good coax ground.
2. Place grounding straps between the 400W Series unit, VHF COM and a good ground.
3. Shield the VHF COM wiring harness.

2.4.7 COM, VOR/LOC, and Glideslope Antenna Installation Instructions

Install the COM, VOR/LOC, and Glideslope antennas according to the manufacturer's recommendations. Avoid running other wires and coaxial cables near the VOR/LOC antenna cable.

2.5 Mounting Considerations

The 400W Series unit is designed to mount in the avionics stack in the aircraft instrument panel within view and reach of the pilot. The primary unit location should minimize pilot head movement when transitioning between looking outside of the cockpit and viewing/operating the 400W Series unit. The location should be such that the 400W Series unit is not blocked by the glare shield on top, or by the throttles, control yoke, etc. on the bottom.

For VFR-only installations, the 400W Series unit must be mounted in the aircraft manufacturer's approved location or other FAA approved location (see Figure 2-2). No CDI/HSI interface is required but if provided, proper source selection annunciation must be used.

In accordance with AC 20-138A, for IFR GPS installations the 400W Series unit must be mounted in the aircraft manufacturer's approved location or other FAA approved location, and the required CDI/HSI must be mounted in the primary field of view. CDI/HSI navigation source selection annunciation must be on or near the affected display and any additional annunciations must be mounted within the normal field-of-view.

An FAA issue paper was written to clarify the TSO-C146a annunciation requirement of "on or near the affected display". This issue paper said, in order to preclude the need for external source selection annunciations (i.e. using the annunciation within the 400W Series unit), the source selection annunciation displayed on the 400W Series unit must be within 13.856 inches of pilot view centerline. If the CDI is to the left or right of centerline, it must favor the same side as the 400W Series unit placement (i.e. typically the radio stack is on the right of the pilot's view centerline, so the CDI should be on the right side of the basic primary flight instruments). A CDI/HSI with a built-in annunciation may also be used in lieu of a separate external annunciator to satisfy the source selection annunciation requirement. In addition, any required GPS navigation annunciations must be within 16.805 inches of the pilot view centerline. If the 400W Series unit display is within this area, then no external GPS navigation annunciations are required.

The 400W Series unit, as a redundant or secondary TSO-C146a certified navigation device, may be installed outside the acceptable view parameters if the unit is used as a backup system. Example: To the right of a center radio stack, when two columns of avionics are available. This places the unit too far from the pilot's normal scan. As such, IFR flights may not originate or be predicated on this unit unless the primary system has failed.

2.5.1 Determination of Acceptable Field-of-View

The FAA has determined that the acceptable field-of-view for TSO C146a annunciations related to navigation source selection is approximately $\pm 30^\circ$ horizontally from the center of the attitude indicator (or centerline of the pilot's seat/yoke), and that the acceptable field-of-view for TSO C146a annunciations related to GPS navigation data is approximately $\pm 35^\circ$ horizontally from the center of the attitude indicator. These angles are based on the closest panel distance of 24 inches resulting in a measured offset from the attitude indicator of 13.856 inches and 16.805 inches respectively.

The acceptable vertical field-of-view includes the area from the top of the instrument panel to the portion of the instrument panel that is immediately below the basic 'T' instruments. An example of the viewing area based on the attitude indicator in an aircraft with basic "T" instruments is depicted in Figure 2-2.

For an IFR-approved GPS installation, the 400W Series unit must be located within the $\pm 35^\circ$ horizontal acceptable field-of-view or source selection and GPS annunciations are required to be installed. If the 400W Series unit is installed between $\pm 30^\circ$ and $\pm 35^\circ$, at a minimum, source selection annunciation must be installed. See Figure 2-3.

2.5.1.1 Source Selection Annunciation

Use the steps below to determine whether or not the integrated source selection annunciation displayed on the 400W Series unit to be installed is within the acceptable field-of-view (see Figure 2-2):

-
1. Determine the pilot's primary view centerline, utilizing the following criteria:
 - a) For aircraft with a basic "T" instrument configuration with the attitude indicator in the upper center location, the center of this instrument should be used as the primary view centerline.
 - b) If the basic "T" is offset away from the radio stack with respect to the control yoke or a non-standard instrument cluster is present in the aircraft, the center of the control yoke or stick, in the neutral position may be used as the primary view centerline.
 - c) If the control yoke/stick is offset from the center of the pilot's seat, an imaginary line extended through the center of the pilot's seat may be used as the primary view centerline.
 2. Measure the horizontal distance from the primary view centerline to the left or right edge of the 400W Series, as appropriate.
 3. If the 400W Series unit is mounted to the **right** of the primary instruments, the internal display of annunciation within the 400W Series unit is considered to be within the acceptable field-of-view if the following criteria are met:
 - The left edge of the 400W Series unit is within 11.8 inches of the primary view centerline and;
 - the top edge of the 400W Series unit is no lower than the bottom edge of the primary flight instruments or the unit is line abreast with the affected CDI.
 4. If the 400W Series unit is mounted to the **left** of the primary instruments, the internal display of annunciation within the 400W Series unit is considered to be within the acceptable field-of-view if the following criteria are met:
 - The right edge of the 400W Series unit is within 9.2 inches of the primary view center line and;
 - the top edge of the 400W Series unit is no lower than the bottom edge of the primary flight instruments or the unit is line abreast with the affected CDI.

If the internal display of annunciation within the 400W Series unit does not meet the criteria for acceptable field-of-view as defined above, an external source selection annunciator must be integrated in the affected CDI/HSI or an additional annunciator which clearly indicates the CDI/HSI source as VLOC or GPS must be installed within 13.856 inches of the view centerline.

NOTE



The entire annunciator must be within 13.856 inches of the view centerline.

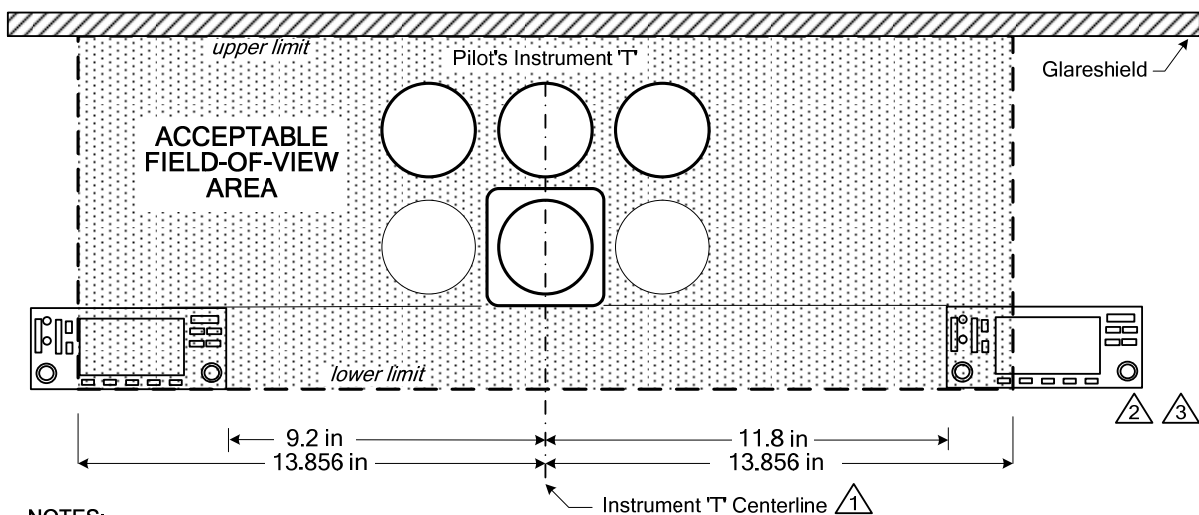

NOTES:

- △1 FOR AIRCRAFT WITHOUT THE BASIC INSTRUMENT 'T' CONFIGURATION, THE CENTER OF THE PILOT'S YOKE OR CONTROL STICK IN THE NEUTRAL POSITION SHOULD BE USED TO DETERMINE THE CENTERLINE. IF THE CONTROL YOKE/STICK IS OFFSET FROM THE CENTER OF THE PILOT'S SEAT, AN IMAGINARY LINE EXTENDED THROUGH THE CENTER OF THE PILOT'S SEAT MAY BE USED AS THE PRIMARY VIEW CENTERLINE.
- △2 THE TOP EDGE OF THE 400W SERIES SHOULD BE NO LOWER THAN THE BOTTOM EDGE OF THE PRIMARY FLIGHT INSTRUMENT.
- △3 FOR AIRCRAFT IN WHICH THE TYPE CERTIFICATED CDI OR HSI LOCATION IS BELOW THE BASIC 'T', THE LOWER LIMIT OF THE ACCEPTABLE FIELD-OF-VIEW SHOULD BE THE BOTTOM OF THE CDI OR HSI.

Figure 2-2. Source Selection Annunciation Field of View

2.5.1.2 GPS Navigation Annunciation

Use the steps below to determine whether or not the integrated GPS navigation annunciation displayed on the 400W Series unit to be installed is within the acceptable field-of-view (see Figure 2-3):

1. Determine the pilot's primary view centerline, as defined in Step 1 of Section 2.5.1.1.
2. Measure the horizontal distance from the primary view centerline to the left or right edge of the 400W Series, as appropriate.
3. If the 400W Series unit is mounted to the **right** of the primary instruments, the internal display of annunciation within the 400W Series unit is considered to be within the acceptable field-of-view if the following criteria are met:
 - The left edge of the 400W Series unit is within 13.4 inches of the primary view centerline and;
 - the top edge of the 400W Series unit is no lower than the bottom edge of the primary flight instruments or the unit is line abreast with the affected CDI.
4. If the 400W Series unit is mounted to the **left** of the primary instruments, the internal display of annunciation within the 400W Series unit is considered to be within the acceptable field-of-view if the following criteria are met:
 - The right edge of the 400W Series unit is within 12.2 inches of the primary view center line and;
 - the top edge of the 400W Series unit is no lower than the bottom edge of the primary flight instruments or the unit is line abreast with the affected CDI.

If the internal display of GPS navigation annunciation within the 400W Series unit does not meet the criteria for acceptable field-of-view as defined above, an external annunciator unit must be installed within 16.805 inches of the view centerline.

NOTE



The entire annunciator unit must be within the acceptable field-of-view.

The external GPS Navigation annunciator unit must contain, at a minimum, the following annunciations:

- INTEG, INTG or LOI
- TERM
- APR
- MSG
- WPT

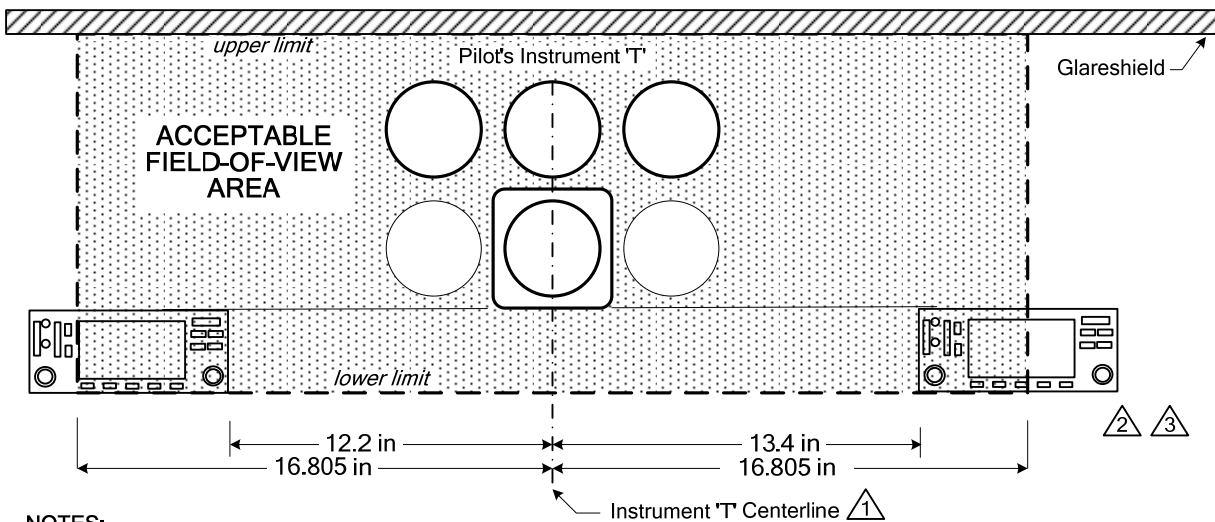

NOTES:

- 1 FOR AIRCRAFT WITHOUT THE BASIC INSTRUMENT 'T' CONFIGURATION, THE CENTER OF THE PILOT'S YOKE OR CONTROL STICK IN THE NEUTRAL POSITION SHOULD BE USED TO DETERMINE THE CENTERLINE. IF THE CONTROL YOKE/STICK IS OFFSET FROM THE CENTER OF THE PILOT'S SEAT, AN IMAGINARY LINE EXTENDED THROUGH THE CENTER OF THE PILOT'S SEAT MAY BE USED AS THE PRIMARY VIEW CENTERLINE.
- 2 THE TOP EDGE OF THE 400W SERIES SHOULD BE NO LOWER THAN THE BOTTOM EDGE OF THE PRIMARY FLIGHT INSTRUMENT.
- 3 FOR AIRCRAFT IN WHICH THE TYPE CERTIFICATED CDI OR HSI LOCATION IS BELOW THE BASIC 'T', THE LOWER LIMIT OF THE ACCEPTABLE FIELD-OF-VIEW SHOULD BE THE BOTTOM OF THE CDI OR HSI.

Figure 2-3. GPS Navigation Annunciator Field of View

2.6 Cabling and Wiring Considerations

Wiring should be installed in accordance with AC 43.13-1B Chapter 11. For dual 400W Series unit installations, care should be taken to ensure separation between wires of redundant systems to reduce the possibility of loss of navigation due to a single event. When wire separation cannot be achieved, the following issues should be addressed:

- It should not be possible for a cable harness to be exposed to wire chafing in a manner that both GPS units fail simultaneously;
- The cable harness should not be located near flight control cables and controls, high electrical capacity lines or fuel lines;
- The cable harness should be located in a protected area of the aircraft (e.g., isolated from engine rotor burst); and
- Do not route cable near high-energy sources.

NOTE



Wiring which is required to be shielded per Appendix H must be shielded. Pigtail lengths must be less than 3.0 inches.

Refer to Section 3.7 and Section 3.8 for connector and tooling information.

Refer to Section 3.10 for recommended coax cable.

Refer to Appendix H for the appropriate wiring connections to assemble the wiring connector.

Once the cable assemblies have been made, attach the cable connectors to the rear connector plate. After installing the mounting tube, attach the assembled connector plate. Route the wiring bundle as appropriate. Use 22 to 24 AWG wire for all connections except for power. Use 20 AWG for power and ground. Avoid sharp bends.

2.7 Air Circulation and Cooling

The 400W Series units meet all TSO requirements without external cooling. However, as with all electronic equipment, lower operating temperatures extend equipment life. On the average, reducing the operating temperature by 15° to 20°C (27° to 36°F) doubles the mean time between failure (MTBF). Recommended airflow rating is 1 CFM (cubic foot per minute) at a pressure equivalent to 0.1 inches of water.

Potential damage to your 400W Series unit may occur by using outside forced air to cool the equipment. Therefore, it is recommended that an electric forced air fan be installed, of the indicated rating, to cool this equipment.

Units tightly packed in the avionics stack heat each other through radiation, convection, and sometimes by direct conduction. Even a single unit operates at a much higher temperature in still air than in moving air. Fans or some other means of moving the air around electronic equipment are usually a worthwhile investment. A 5/8 inch diameter air fitting is provided on the rear of the mounting rack for the purpose of admitting cooling air under such conditions. If a form of forced air cooling is installed, make certain that rainwater cannot enter and be sprayed on the equipment.

2.8 Compass Safe Distance

After reconfiguring the avionics in the cockpit panel, if the 400W Series unit is mounted less than 12 inches from the compass, recalibrate the compass and make the necessary changes for noting correction data.

2.9 Installation Approval Considerations

In most cases, AML STC SA01933LA only covers the interfaces in Appendix G. However, as described in the following sections, specific interfaces not listed in Appendix G can be approved under AML STC SA01933LA.

2.9.1 Autopilot Interface Approval

The 400W Series units have been approved to interface with a number of autopilots. Autopilots that will be coupled to GPS *vertical* guidance for GPS approaches **must** be specifically listed in Appendix G.

Autopilots not listed in Appendix G can still be approved under 400W/500W Series AML STC SA01933LA if **all** of the following conditions are met:

- The installation of the autopilot was previously FAA-approved;
- All interfaces between the 400W Series unit and the autopilot are analog;
- The installation must use existing navigation signals which interface the autopilot to a standard VHF navigation receiver (i.e. CDI/HSI L/R and Up/Dn)
- A successful in-air flight check must be completed prior to returning the aircraft to service.
- The AFMS is properly completed, limiting the GPS to lateral coupling only (LNAV)

If these conditions are met the interface can be approved under AML STC SA01933LA. These autopilots are limited to those operations for which they were previously FAA-approved when interfaced with the other TC'd or STC'd navigation units (e.g. if the previous unit was installed and approved for coupled VOR, ILS, LOC, BC and GPS LNAV approaches, this upgraded installation will also be approved for these operations; however, GPS and RNAV approaches with GPS/WAAS-based vertical guidance (LNAV+V,L/VNAV and LPV modes on the 400W series unit) are not authorized when coupled to the autopilot).

NOTE



Contact Garmin to remove VNAV limitations.

2.9.2 Altitude Encoder/Air Data Computer Interface Approval

The 400W Series units have been approved to interface with a number of altitude encoders. However, altitude encoders not listed in Appendix G can still be approved under 400W/500W Series AML STC SA01933LA if **all** of the following conditions are met:

- The altitude encoder/air data computer is TSO approved;
- The installation of the altitude encoder / air data computer was previously FAA-approved;
- The interface check for the altitude encoder described in section 5.4.4 (serial interface) or 5.4.5 (parallel/gray code interface) must be successfully completed.

If these conditions are met the interface can be approved under AML STC SA01933LA.

2.9.3 Audio Panel Interface Approval

The 400W Series units have been approved to interface with a number of audio panels. However, audio panels not listed in Appendix G can still be approved under 400W/500W Series AML STC SA01933LA if **all** of the following conditions are met:

- The installation of the audio panel was previously FAA-approved;
- The VHF COM audio and VHF NAV audio (if applicable) must be verified as described in sections 5.5.4 and 5.5.5.

If these conditions are met the interface can be approved under AML STC SA01933LA.

This page intentionally left blank

3. INSTALLATION PROCEDURES

3.1 Unit and Accessories

The 400W Series units are available under the following part numbers:

Table 3-1. Catalog Part Numbers

Model	Unit Only Kit	Standard Kit	Unit P/N	Color	COM	NAV	Voltage (VDC)	Upgrade
GPS 400W	010-00409-00	010-00409-01	011-01057-00	BLK			14/28	
	010-00409-10	010-00409-11	011-01057-10	GRY			14/28	
	010-00409-40	010-00409-41	011-01057-40	BLK			14/28	X
	010-00409-50	010-00409-51	011-01057-50	GRY			14/28	X
GNC 420W	010-00410-00	010-00410-01	011-01058-00	BLK	10W		14/28	
	010-00410-10	010-00410-11	011-01058-10	GRY	10W		14/28	
	010-00410-40	010-00410-41	011-01058-40	BLK	10W		14/28	X
	010-00410-45	010-00410-46	011-01058-45	BLK	10W		28	X
	010-00410-50	010-00410-51	011-01058-50	GRY	10W		14/28	X
GNC 420AW	010-00411-00	010-00411-01	011-01059-00	BLK	16W		28	
	010-00411-10	010-00411-11	011-01059-10	GRY	16W		28	
	010-00411-40	010-00411-41	011-01059-40	BLK	16W		28	X
	010-00411-50	010-00411-51	011-01059-50	GRY	16W		28	X
GNS 430W	010-00412-00	010-00412-01	011-01060-00	BLK	10W	X	14/28	
	010-00412-10	010-00412-11	011-01060-10	GRY	10W	X	14/28	
	010-00412-40	010-00412-41	011-01060-40	BLK	10W	X	14/28	X
	010-00412-45	010-00412-46	011-01060-45	BLK	16W	X	28	X
	010-00412-50	010-00412-51	011-01060-50	GRY	10W	X	14/28	X
GNS 430AW	010-00413-00	010-00413-01	011-01061-00	BLK	16W	X	28	
	010-00413-10	010-00413-11	011-01061-10	GRY	16W	X	28	
	010-00413-40	010-00413-41	011-01061-40	BLK	16W	X	28	X
	010-00413-50	010-00413-51	011-01061-50	GRY	16W	X	28	X

Table 3-2. Standard Kit Accessories

Model	Item	Part Number
GPS 400W	Mounting Rack	115-00243-00
	Connector Kit	011-00351-03
	Back Plate Assembly	011-00676-03
	Product Information Kit	K00-00162-00
GNC 420W and GNC 420AW	Mounting Rack	115-00243-00
	Connector Kit	011-00351-01
	Back Plate Assembly	011-00676-01
	Product Information Kit	K00-00162-00
GNS 430W and GNS 430AW	Mounting Rack	115-00243-00
	Connector Kit	011-00351-00
	Back Plate Assembly	011-00676-00
	Product Information Kit	K00-00162-00

3.2 Optional Accessories

3.2.1 GPS Antenna Options

For details regarding antenna selection, refer to Section 1.4.8. Once the antenna type is decided upon, refer to the information below for detailed parts information for antennas available directly from Garmin. Contact manufacturer directly for information on other antennas. Installation information for the antennas can be found in the appropriate installation manual listed in Section 3.5.

NOTE



Kits for the GA 56A, GA 56W, GA 57, A33, and A34 antennas are no longer available.

GA 35 Antenna:

GA 35 Antenna Garmin P/N 013-00235-00 contains the following items:

ITEM	PART NUMBER	QTY
GA 35 GPS/WAAS Antenna [1]	013-00235-00 (Garmin)	1
	AT575-93G (Aero Antenna)	

[1] Antenna includes 8-32 UNC-2A x 1.00" SS 303 mounting screws (qty 4) and O-ring (qty 1).

An antenna doubler may also be required. Refer to Section 3.2.2 below for additional information.

To secure the antenna #8 washers (qty 4) and #8 (qty 4) self-locking nuts are required in addition to the antenna, or suitable nutplates may be installed on the doubler.

To connect the GPS antenna coaxial cable to the antenna a TNC plug is required.

GA 36 Antenna:

GA 36 Antenna Garmin P/N 013-00244-00 contains the following items:

ITEM	PART NUMBER	QTY
GA 36 GPS/WAAS Antenna [1]	013-00244-00 (Garmin)	1
	AT575-126G (Aero Antenna)	

[1] Antenna includes 8-32 UNC-2A x 1.00" SS 303 mounting screws (qty 4) and O-ring (qty 1).

An antenna doubler may also be required. Refer to Section 3.2.2 below for additional information.

To secure the antenna #8 washers (qty 4) and #8 (qty 4) self-locking nuts are required in addition to the antenna, or suitable nutplates may be installed on the doubler.

To connect the GPS antenna coaxial cable to the antenna a TNC plug is required.

GA 37 Antenna:

GA 37 Antenna Garmin P/N 013-00245-00 contains the following items:

ITEM	PART NUMBER	QTY
GA 37 GPS/WAAS + XM Antenna [1]	013-00245-00 (Garmin)	1
	AT2300-126G (Aero Antenna)	

[1] Antenna includes 8-32 UNC-2A x 1.00" SS 303 mounting screws (qty 4) and O-ring (qty 1).

An antenna doubler may also be required. Refer to Section 3.2.2 below for additional information.

To secure the antenna #8 washers (qty 4) and #8 (qty 4) self-locking nuts are required in addition to the antenna, or suitable nutplates may be installed on the doubler.

To connect the GPS antenna coaxial cable to the antenna a TNC plug is required.

3.2.2 GPS Antenna Doubler

If installing the antenna onto existing provisions a doubler may not be required. If installing the antenna using AML STC SA01695SE as the basis for approval, one of the following antenna doublers may be used:

- Antenna doubler P/N 115-00846-00, for the GA 36 and GA 37 antennas. This doubler contains nut plates (qty. 4) for the antenna mounting screws.
- Antenna doubler P/N 115-00846-10, for the GA 35 antenna. This doubler does not contain nut plates.

The above doublers may be purchased from Garmin or doublers may be fabricated in accordance with the Antenna STC Installation Manual 190-00569-00.

3.2.3 Other Accessories

None.

3.3 Database Options

ITEM	GARMIN P/N
Data Card, World Wide	010-10546-00
Data Card, Americas	010-10546-01
Data Card, International	010-10546-02
Data Card, Taws/Terrain (128 MB) (Note 1)	010-10201-20
Data Card, Taws/Terrain (256 MB) (Note 1)	010-10201-21

Note 1: Data cards 010-10201-20 and 010-10201-21 are functionally equivalent.

3.4 Miscellaneous Options

ITEM	GARMIN P/N
Connector, BNC, Male, Clamp	330-00087-00
GPS 1.57542 GHz Notch Filter	330-00067-00

3.5 Optional Reference Material

ITEM	GARMIN P/N
400W Series Pilot's Guide	190-00356-00
400W Series Quick Reference Guide	190-00356-01
Addendum – 400W/500W Series Display Interfaces	190-00356-31
Addendum – 400W/500W Series Garmin Optional Displays	190-00356-30
GNS 400W/500W Series Training CD	010-10601-00

GA Antenna AML STC SA01695SE Documentation:

ITEM	GARMIN P/N
Master Data List	005-C0373-00
STC Antenna Installation Manual	190-00569-00
Instructions for Continued Airworthiness	190-00673-01

3.6 Installation Materials Required but Not Provided

3.6.1 Optional Accessories Not Supplied (GNC 420W and GNS 430W Only)

The following installation accessories are required but not provided:

ITEM	REQUIREMENTS
COM Antenna	Shall meet TSO C37() and C38(). Broad band, 50 Ω, vertically polarized with coaxial cable (GNC 420W and GNS 430W Only)
VOR/LOC Antenna	Shall meet TSO C40() and C36(). Broad band, 50 Ω, horizontally polarized with coaxial cable (GNS 430W Only)
Glideslope Antenna	Shall meet TSO C34(). Broad band, 50 Ω, horizontally polarized with coaxial cable or low-loss splitter used with the VOR/LOC antenna (GNS 430W Only)
Headphones	500Ω nominal impedance (GNC 420W and GNS 430W Only)
Microphone	Low impedance, carbon or dynamic, with transistorized pre-amp (GNC 420W and GNS 430W Only)

For a list of optional accessories and source selection annunciators, refer to Appendix G.

3.6.2 Materials Required But Not Supplied (New Installations Only)

The 400W Series unit is intended for use with the standard aviation accessories. The following items are required for installation, but not supplied:

- Wire (MIL-W-22759/16 or equivalent)
- Shielded Wire (MIL-C-27500 or equivalent)
- Mounting Screws (8 minimum – AN577 6-32 screw with 100° countersink)
- Circuit Breakers
- Tie Wraps or Lacing Cord
- Ring Terminals (for grounding)
- Coaxial Cable (RG-400, RG-142B or equivalent – refer to Section 3.10 for addition information)

3.7 Special Tools Required

Some of the connectors use crimp contacts. The table below identifies crimp tools required to ensure consistent, reliable crimp contact connections for the rear D-sub connectors.

Table 3-3. Recommended Crimp Tools (or Equivalent)

Connector Type	Wire Gauge	High Density		Standard Density			
		22-24 AWG		18 AWG		20-24 AWG	
	Hand Crimping Tool	Positioner	Insertion/ Extraction Tool	Positioner	Insertion/ Extraction Tool	Positioner	Insertion/ Extraction Tool
Military P/N	M22520/2-01	M22520/2-09	M81969/1-04	N/A	M81969/1-02	M22520/2-08	M81969/1-02
Positronic	9507	9502-3	M81969/1-04	9502-11	M81969/1-02	9502-5	M81969/1-02
ITT Cannon	995-0001-584	995-0001-739	N/A	N/A	N/A	995-0001-604	980-2000-426
AMP	601966-1	601966-6	91067-1	N/A	N/A	601966-5	91067-2
Daniels	AFM8	K42	M81969/1-04	K774	M81969/1-02	K13-1	M81969/1-02
Astro	615717	615725	M81969/1-04	N/A	M81969/1-02	615724	M81969/1-02

NOTE



Insertion/extraction tools from ITT Cannon are all plastic; others are plastic with metal tip.

3.8 Cable Installation

1. Route the coaxial cable to the rack location keeping in mind the recommendations of Section 2.6. Secure the cable in accordance with good aviation practice.
2. Trim the coaxial cable to the desired length and install the BNC connector (330-00087-00) per the cabling instructions on Figure 3-1. If the connector is provided by the installer, follow the connector manufacturer's instructions for cable preparation.

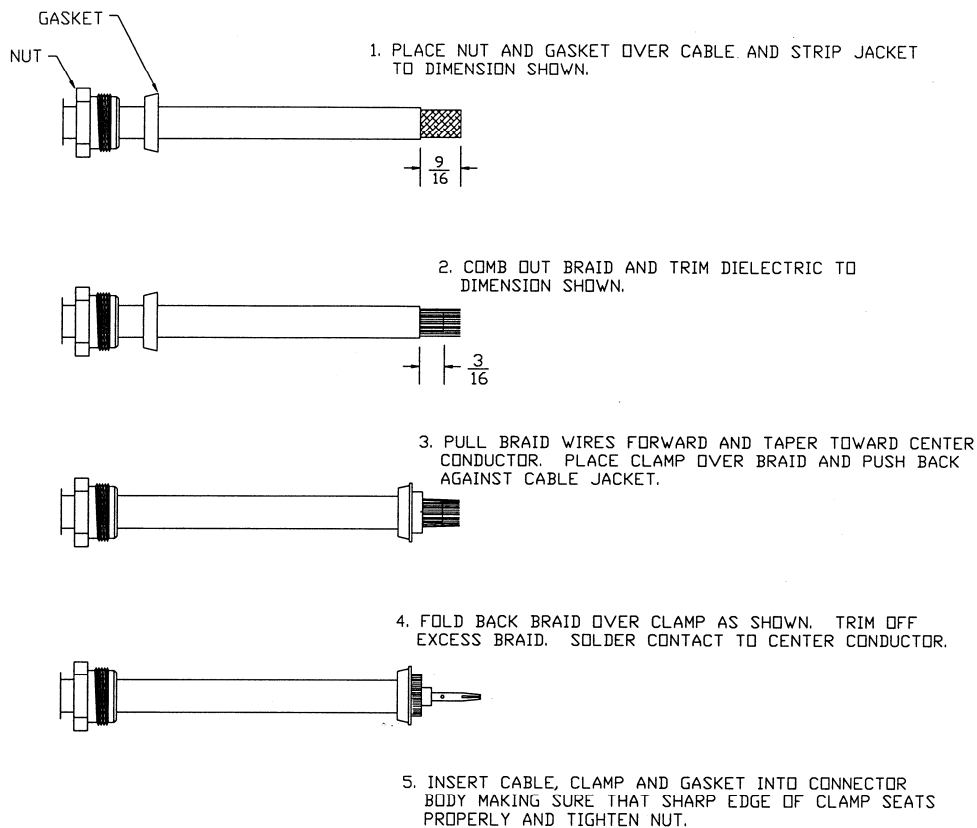

Figure 3-1. Coaxial Cable Installation

The card-edge connector may be used to terminate shield grounds to the 400W Series back plate.

Feed wires through the connector backshells before insertion into the 25-, 44-, and 78-pin connectors. Contacts for the 25-, 44-, and 78-pin connectors must be crimped onto the individual wires of the aircraft wiring harness. The following table lists contact part numbers (for reference). See Table 3-3 for recommended crimp tools.

Table 3-4. Pin Contact Part Numbers

	78-pin conn (P4001)	44-pin conn (P4006)	25-pin Connector (P4002)		Shield Ground Connector
Connector Type	High Density Pin Contact		Standard Density Socket Contact		.1-inch Pitch Card-Edge
Wire Gauge	22-24 AWG		18 AWG	20-24 AWG	20-24 AWG
Garmin P/N	336-00021-00		336-00023-00	336-00022-00	336-00029-00
Military P/N	M39029/58-360		N/A	M39029/63-368	N/A
AMP	204370-2		N/A	205090-1	583853-4
Positronic	M39029/58-360		FC6018D	M39029/63-368	N/A
ITT Cannon	030-2042-000		See Note 2	031-1007-042	N/A

NOTES

1. Non-Garmin part numbers shown are not maintained by Garmin and consequently are subject to change without notice.
2. Alternate contacts for 18 AWG wire: As an alternative to the Positronic contacts listed (and provided in the installation kit), the installer may use contacts made by ITT Cannon under P/N 031-1007-001. These contacts require the use of a different crimp tool positioner than shown in the table, with the part numbers as follows: Daniels P/N K250, Astro P/N 616245, or ITT Cannon P/N 980-0005-722.
3. For the card-edge connector pin contacts, use AMP part number 90272-1 or equivalent crimping tool.

To prevent a possible short across the pins in the wiring harness, Teflon shrink tubing P/N 312-00005-05, provided in Connector Kit 011-00351-00 (P4002) covers the oversized power and ground pin contacts P/N 336-00023-00 (pins 11, 12, 21, 22) that protrude from the back of the connector shell. Before crimping the pins onto the wire:

1. Cut the tubing (312-00005-05) into 4 equal lengths.
2. Slide a short piece of the tubing over the wire.
3. Strip the wire and crimp the pin (336-00023-00) onto the wire.
4. Insert the pin into the connector shell.
5. Slide the tubing over the exposed portion of the pin and shrink using a heat gun.

3.9 Equipment Mounting

3.9.1 Rack Installation

Use the dimensions shown in Figure F-1 to prepare the mounting holes for the 400W Series unit. You may also use the 400W Series unit mounting rack itself as a template for drilling the mounting holes.

1. The back plate of the rack may optionally be removed for ease of mounting in the aircraft panel. To do so, remove the two #4-40 screws, tilt the back plate away from the tray, and then slide the back plate to the side.
2. Use the dimensions shown in Figure F-1 for the aviation rack for the various 400W Series units. Install the rack in a rectangular 6.320" x 2.700" hole (or gap between units) in the instrument panel. The lower-front lip of the rack should be flush with, or extend slightly beyond, the finished aircraft panel.

NOTE



If the front lip of the mounting rack is behind the surface of the aircraft panel, the 400W Series unit connectors may not fully engage.

Make sure that no screw heads or other obstructions prevent the unit from fully engaging in the rack (refer to the "Connector Engagement Test," Section 5.2). Exercise caution when installing the rack into the instrument panel. The rack is designed to facilitate removal of the 400W Series for use in Demo Mode outside the aircraft. Deformation of the rack may make it difficult to install and remove the 400W Series unit.

3. Install the rack in the aircraft panel using six #6-32 flat head screws and six self-locking nuts. The screws are inserted from the inside through the holes in the sides of the rack.
4. If the back plate was previously removed (see Step #1), replace the back plate by positioning the tabs on the back plate in the slots of the left side of the rack (viewing it from the cockpit) and attaching it by replacing the two #4-40 screws.

3.9.2 400W Series Unit Insertion and Removal

It may be necessary to insert the hex drive tool into the access hole and rotate the mechanism 90° counterclockwise to insure correct position prior to placing the unit in the rack. The 400W Series unit is installed in the rack by sliding it straight in until it stops, about 1 inch short of the final position. A 3/32-inch hex drive tool is then inserted into the access hole at the bottom of the unit face. Rotate the hex tool clockwise while pressing on the left side of the bezel until the unit is firmly seated in the rack.

To remove the unit from the rack, insert the hex drive tool into the access hole on the unit face and rotate counterclockwise until the unit is forced out about 3/8 inches and can be freely pulled from the rack.

Be sure not to over tighten the unit into the rack. The application of hex drive tool torque exceeding 15 in-lbs can damage the locking mechanism.

3.9.3 Unit Replacement

Whenever the 400W Series unit is removed or reinstalled, verify that the unit power-up self-test sequence is successfully completed and no failure messages are annunciated. Section 5.5.1 outlines the power-up self-test sequence.

3.10 Antenna Installation and Connection

3.10.1 GPS Antenna

This section provides information on the antenna cable installation. For mounting of the GPS Antenna refer to the Garmin GA Antenna AML STC SA01695SE. Refer to 2.4.1 herein for installation location considerations.

NOTE



The internal 400W Series COM does not interfere with its own GPS receiver. However, placement of the 400W Series antenna relative to other COM transceivers and antennas (including the 400W Series COM antenna) is critical.

Suggestion: *Temporarily locate the GPS antenna with coax connected to the 400W Series unit and check the GPS performance as described in Section 5.5.2 and Section 5.5.3. Once a suitable location has been verified, then permanently mount the antenna.*

Once the antenna mounting position has been prepared, route the coax cable from the antenna to the 400W Series unit. Proper selection of coax cable and assembly of connectors is critical to GPS signal performance. **The cable loss from the GPS antenna (excluding antennas in Table 1-3) shall be between 1.5 dB and 6.5 dB in order to maintain proper rejection to interference signals.**

NOTE



GPS antennas in Table 1-3 require a cable loss between 3 dB and 7 dB.

The coaxial connectors and adapters, such as TNC to BNC, add additional loss to the cable and should be considered when computing the cable loss. A typical loss of 0.2 dB can be used for each connection. To maintain integrity of the WAAS signal, the GPS antenna coaxial cable must have a minimum of two shields (e.g. RG-400 or RG-142B).

NOTE



If RG-142B or RG-400 is used, 1.5 dB equates to a length of approximately 6.5 feet of cable with a connector on each end. RG-142B or RG-400 cable can be used as long as the length is less than 35 feet. For longer lengths, use low-loss double or triple shielded 50Ω coax.

For very short runs, where the loss is less than 1.5 dB, additional cable should be used to increase the loss to within 1.5 dB to 6.5 dB. This additional cable may be coiled, taking into account the minimum bend radius of the cable.

During the post-installation checkout, susceptibility to harmonics of VHF COM transmitters will be evaluated. If problems arise, then better isolation, or distance, may be required between the GPS and COM antennas, or a 1575.42 MHz notch filter may be installed in series with the antenna coax of the VHF COM transceiver to reduce or eliminate the harmonic interference. A notch filter for this use (P/N 330-00067-00) is available from Garmin.

If a VHF COM transmitter causes problems with the GPS on the selected frequencies as listed in the post-installation checkout, the problem may be due to the ELT. This can be verified by disconnecting the ELT antenna coax at the ELT unit. If the ELT is found to cause the problem, then contact the ELT manufacturer or replace the ELT.

3.10.2 COM Antenna

The 400W Series unit requires a standard 50Ω vertically polarized antenna. Follow the antenna manufacturer's installation instructions for mounting the antenna.

The antenna should be mounted on a metal surface or a ground plane with a minimum area of 18 x 18 inches. Refer to Section 2.4.2 for installation location considerations.

The antenna coax cable should be made of RG-142B, RG-400 or a comparable quality 50Ω coax.

Check for insertion loss and VSWR (voltage standing wave ratio). VSWR should be checked with an in-line type VSWR/wattmeter inserted in the coaxial transmission line between the transceiver and the antenna. The VSWR should be inserted as close to the transceiver as possible. When rack and harness buildup is performed in the shop, the coax termination may be provisioned by using a 6 inches inline BNC connection. This would be an acceptable place to insert the VSWR. Any problem with the antenna installation is most likely seen as high reflected power. A VSWR of 3:1 may result in up to a 50% loss in transmit power.

3.10.3 NAV Antenna

The NAV antenna is a standard 50Ω horizontally polarized NAV/VOR/Localizer/Glideslope antenna (the glideslope may be a separate antenna in some aircraft) that receives VOR frequencies between 108 and 117.95 MHz, and localizer frequencies between 108 and 112 MHz, and glideslope information between 328.6 and 335.4 MHz. Follow the antenna manufacturer's installation instructions for mounting antennas. It is recommended that the installer use RG-142B, RG-400 or equivalent 50Ω coax for the NAV antenna(s).

The GNS 430W has a separate VOR/LOC and Glideslope inputs requiring some installations to use a standard external diplexer or triplexer.

3.11 Weight and Balance

Weight and balance computation is required after the installation of the 400 Series unit. Follow the guidelines as established in AC 43.13-1B, Chapter 10, Section 2. Make appropriate entries in the equipment list indicating items added, removed, or relocated along with the date accomplished. Include your name and certificate number in the aircraft records. Table 3-5 identifies the weight of the new 400W Series equipment. Refer to Figure F-1 for the center of gravity.

Table 3-5. Unit Weights

GPS 400W Weight (Unit only)	4.0 lbs. (1.82 kg)
GPS 400W Weight (Installed with rack and back plate)	5.0 lbs. (2.27 kg)
GNC 420W and 420AW Weight (Unit only)	4.5 lbs. (2.04 kg)
GNC 420W and 420AW Weight (Installed with rack and back plate)	5.5 lbs. (2.49 kg)
GNS 430W and 430AW Weight (Unit only)	5.1 lbs (2.31 kg)
GNS 430W and 430AW Weight (Installed with rack and back plate)	6.2 lbs (2.81 kg)

3.12 Electrical Load Analysis

An electrical load analysis should be completed on each aircraft prior to installation in accordance with AC 43.13-1B, Chapter 11. Use the following values for computation:

Table 3-6. 400W Series Power Input

Input	Connector	Mode	14 VDC		28 VDC	
			Typical	Max	Typical	Max
GPS 400W						
Main power	P4001	--	760mA	1.4A	410mA	700mA
GNC 420W						
Main power	P4001	--	1.12A	2.5A	560mA	1.2A
COM power	P4002	RX	4mA	15mA	8mA	15mA
		TX	3.25A	6.0A	1.6A	3.0A
GNC 420AW						
Main power	P4001	--	1.12A	2.5A	560mA	1.2A
COM power	P4002	RX	N/A	N/A	3mA	15mA
		TX	N/A	N/A	1.6A	3.0A
GNS 430W						
Main power	P4001	--	1.60A	2.5A	800mA	1.2A
COM power	P4002	RX	4mA	15mA	8mA	15mA
		TX	3.25A	6.0A	1.60A	3.0A
GNS 430AW						
Main power	P4001	--	1.60A	2.5A	800mA	1.2A
COM power	P4002	RX	N/A	N/A	3mA	15mA
		TX	N/A	N/A	1.6A	3.0A

NOTE



The input currents do not include loads on the superflag outputs.

3.13 AFMS Completion – Based on Autopilot Type

3.13.1 Autopilot Listed in 400W/500W Series AML STC

For all autopilots listed in Section G.4, the appropriate limitations for that autopilot are identified in Table 3-7 and described in the paragraphs following the table.

Table 3-7. Autopilot Coupling Limitations

Manufacturer	Model	Capabilities			Limitations		Notes
		Lateral	Vertical	GPSS	Section 2.8 of AFMS	Section 4.3 of AFMS	
Honeywell (Bendix/King)	KAP 100	X			[a]	[4]	
	KAP 150	X	X		[a]	[3]	
	KAP 140	X	X		[a]	[1]	
	KCP 320	X	X		[a]	[3]	
	KFC 150/200/250/300/325	X	X		[a]	[3]	
	KFC 225	X	X	X	[a]	[1]	ARINC 429 roll steering
Century	I/II	X			[a]	[4]	
	III/IV	X	X		[a]	[3]	
	21	X		(ii)	[a]	[4]	
	31/41	X	X	(ii)	[a]	[3]	
	2000	X	X	(ii)	[a]	[3]	
	Triden	X	X	(ii)	[a]	[3]	
S-TEC	System 20/30/40/50	X		(i)	[a]	[4]	
	System 55	X	X	(i)	[a]	[3]	
	System 55X	X	X	X	[a]	[2]	ARINC 429 roll steering
	System 60-1	X		(i)	[a]	[4]	
	System 60-2/65	X	X	(i)	[a]	[3]	
	System 60 PSS		X		[a]	[3]	
Cessna	300B/400B/800B	X	X		[a]	[3]	
Bendix	M4C/M4D	X	X		[a]	[3]	
Collins	APS 65()	X	X		[a]	[3]	

(i) Roll steering may be provided through the ST-901 GPSS converter.

(ii) Roll steering may be provided through the AK 1081 GPSS converter.

AFMS Section 2.8 Autopilot Coupling Limitations

This section of the AFMS contains two possible limitations:

[a] No limitations for autopilot coupling.

[b] Lateral GPS coupling (LNAV only). For 430W/530W units: The GS of an ILS (VLOC) may be coupled to the autopilot without any limitations.

For all autopilots covered by the 400W/500W Series AML STC, limitation [a] applies and should be checked on the AFMS.

AFMS Section 4.3 Autopilot Coupling Limitations

This section of the AFMS contains four possible limitations:

- [1] This installation prompts the pilot and requires the pilot to enable the A/P outputs just prior to engaging the autopilot in APR mode.
- [2] This installation supports a seamless transition from digital (GPSS) to analog guidance for the autopilot. To capture the vertical guidance, the pilot may engage the autopilot in APR mode at any time when the GPS Glide Slope (VDI) becomes valid (displayed without a FLAG).
- [3] This installation interfaces to the autopilot in analog mode only. To capture the vertical guidance, the pilot may engage the autopilot in APR mode at any time when the GPS Glide Slope (VDI) becomes valid.
- [4] The autopilot does not support any vertical capture or tracking in this installation.

For all autopilots listed in the 400W/500W Series AML STC, the appropriate limitations for that autopilot are identified in Table 3-7. The corresponding limitation should be checked in the AFMS.

3.13.2 Autopilot Not Listed in 400W/500W Series AML STC

If an installation has an autopilot interface that is not listed in the 400W/500W Series AML STC, additional FAA approval is required. However, the AFMS provided with the AML STC should still be used, with the appropriate limitations specified as described below.

AFMS Section 2.8 Autopilot Coupling Limitations

This section of the AFMS contains two possible limitations:

- [a] No limitations for autopilot coupling.
- [b] Lateral GPS coupling (LNAV only). For 430W/530W units: The GS of an ILS (VLOC) may be coupled to the autopilot without any limitations.

For all autopilots that are not listed in the 400W/500W Series AML STC, limitation [b] applies. Additional FAA approval from the Aircraft Certification Office (ACO) is required for a particular installation to remove the vertical GPS coupling limitations.

AFMS Section 4.3 Autopilot Coupling Limitations

This section of the AFMS contains four possible limitations:

- [1] This installation prompts the pilot and requires the pilot to enable the A/P outputs just prior to engaging the autopilot in APR mode.
- [2] This installation supports a seamless transition from digital (GPSS) to analog guidance for the autopilot. To capture the vertical guidance, the pilot may engage the autopilot in APR mode at any time when the GPS Glide Slope (VDI) becomes valid (displayed without a FLAG).
- [3] This installation interfaces to the autopilot in analog mode only. To capture the vertical guidance, the pilot may engage the autopilot in APR mode at any time when the GPS Glide Slope (VDI) becomes valid.
- [4] The autopilot does not support any vertical capture or tracking in this installation.

For all autopilots that are not listed in the 400W/500W Series AML STC, select the appropriate limitation as follows:

Limitation [1] is checked for any installation that meets all of the following criteria:

- The GPS SELECT discrete is set to ‘Prompt’ on the Main System Config Page (refer to section 5.3.3. in the appropriate installation manual).

NOTE



The 400W/500W Series GPS SELECT discrete output is connected to the GPS Select input (or equivalent) on the autopilot. This input is used by the autopilot to determine if the navigation source is GPS or VLOC. The autopilot typically goes to “wings-level” mode automatically when the navigation source changes between GPS and VLOC. In order to prevent the autopilot from entering “wings-level” mode without the pilot noticing the mode change, the unit prompts the pilot and requires pilot acknowledgement prior to switching the output signal state. Examples of autopilots that support this input are the Honeywell KAP 140 or KFC 225.

Limitation [2] is checked for any installation that meets all of the following criteria:

- The GPS SELECT discrete output is configured for ‘Auto’ on the Main System Config Page (refer to section 5.3.3. in the appropriate installation manual).
- ARINC 429 GPSS provided directly to the autopilot computer or through a roll-steering converter.
- The 400W/500W interface to the autopilot provides vertical deviation information.

Limitation [3] is checked for any installation that meets all of the following criteria:

- The GPS SELECT discrete is set to ‘Auto’ on the Main System Config Page (refer to section 5.3.3. in the appropriate installation manual).
- GPS roll-steering information is not provided to the autopilot computer.
- The 400W/500W interface to the autopilot provides vertical deviation information.

Limitation [4] is checked for any installation that meets all of the following criteria:

- The GPS SELECT discrete is set to ‘Auto’ on the Main System Config Page (refer to section 5.3.3. in the appropriate installation manual).
- The 400W/500W interface to the autopilot provides no vertical deviation information (this is the case for autopilots with LNAV and altitude hold modes only i.e. the autopilot does not provide vertical capture and/or vertical tracking).

4. SYSTEM INTERCONNECTS

4.1 Pin Function List

4.1.1 P4001 Main Connector

(View looking at rear of unit)

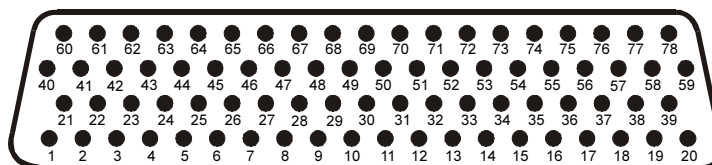

Pin	Pin Name	I/O
1	VLOC ANNUNCIATE	Out
2	GPS ANNUNCIATE	Out
3	WAYPOINT ANNUNCIATE	Out
4	TERMINAL ANNUNCIATE	Out
5	APPROACH ANNUNCIATE	Out
6	MESSAGE ANNUNCIATE	Out
7	OBS ANNUNCIATE	Out
8	SPARE ANNUNCIATE	Out
9	INTEGRITY ANNUNCIATE	Out
10	ANNUNCIATE D	Out
11	ANNUNCIATE E	Out
12	ALTITUDE ALARM ANNUNCIATE	Out
13	GPS SELECT	Out
14	ILS/GPS APPROACH	Out
15	AIRCRAFT POWER 2	In
16	TIME MARK OUT	Out
17	MAIN LATERAL SUPERFLAG	Out
18	MAIN VERTICAL SUPERFLAG	Out
19	AIRCRAFT POWER 1	In
20	AIRCRAFT POWER 1	In
21	MAIN +LEFT	Out
22	MAIN +RIGHT	Out
23	MAIN LATERAL +FLAG	Out
24	MAIN LATERAL -FLAG (GROUND)	Out
25	MAIN +TO	Out
26	MAIN +FROM	Out
27	MAIN +UP	Out
28	MAIN +DOWN	Out
29	MAIN VERTICAL +FLAG	Out
30	MAIN VERTICAL -FLAG (GROUND)	Out
31	MAIN OBS ROTOR C	Out
32	MAIN OBS ROTOR H (GROUND)	Out
33	MAIN OBS STATOR D	In
34	MAIN OBS STATOR E (2.5V COMMON OBS)	Out
35	MAIN OBS STATOR F	In
36	MAIN OBS STATOR G (2.5V COMMON OBS)	Out
37	AUDIO 1 HI	Out
38	AUDIO 1 LO (GROUND)	Out
39	LIGHTING BUS HI	In
40	LIGHTING BUS LO	In
41	GPS RS-232 OUT 3	Out

Pin	Pin Name	I/O
42	GPS RS-232 IN 3	In
43	MAIN OBI CLOCK	Out
44	MAIN OBI DATA	Out
45	MAIN OBI SYNC	Out
46	GPS ARINC 429 OUT A	Out
47	GPS ARINC 429 OUT B	Out
48	GPS ARINC 429 IN 1 A	In
49	GPS ARINC 429 IN 1 B	In
50	GPS ARINC 429 IN 2 A	In
51	GPS ARINC 429 IN 2 B	In
52	RESERVED	--
53	RESERVED	--
54	GPS RS-232 OUT 4	Out
55	GPS RS-232 IN 4	In
56	GPS RS-232 OUT 1	Out
57	GPS RS-232 IN 1	In
58	GPS RS-232 OUT 2	Out
59	GPS RS-232 IN 2	In
60	ALTITUDE COMMON (GROUND)	Out
61	ALTITUDE C4	In
62	ALTITUDE C2	In
63	ALTITUDE C1	In
64	ALTITUDE B4	In
65	ALTITUDE B2	In
66	ALTITUDE B1	In
67	ALTITUDE A4	In
68	ALTITUDE A2	In
69	ALTITUDE A1	In
70	ALTITUDE D4	In
71	OBS MODE SELECT	In
72	AIRCRAFT POWER 2	In
73	CDI SOURCE SELECT	In
74	COM REMOTE RECALL [1]	In
75	DEMO MODE SELECT	In
76	RESERVED	--
77	AIRCRAFT GROUND	--
78	AIRCRAFT GROUND	--

[1] Main software version 3.00 or later

4.1.2 P4002 COM Connector (GNC 420W and GNS 430W Only)

(View looking at rear of unit)

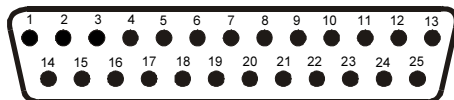

Pin	Pin Name	I/O
1	RESERVED	--
2	RESERVED	--
3	RESERVED	--
4	COM MIC KEY	In
5	INTERCOM MIC HI	In
6	COM MIC AUDIO HI	In
7	500Ω COM AUDIO HI	Out
8	RESERVED	--
9	RESERVED	--
10	RESERVED	--
11	AIRCRAFT POWER	In
12	AIRCRAFT POWER	In
13	RESERVED	--
14	TRANSMIT INTERLOCK	In
15	COM REMOTE TRANSFER	In
16	SPARE	--
17	INTERCOM MIC LO	In
18	COM MIC AUDIO LO	In
19	500Ω COM AUDIO LO	Out
20	RESERVED	--
21	AIRCRAFT GROUND	--
22	AIRCRAFT GROUND	--
23	RESERVED	--
24	RESERVED	--
25	RESERVED	--

4.1.3 P4006 NAV Connector (GNS 430W Only)

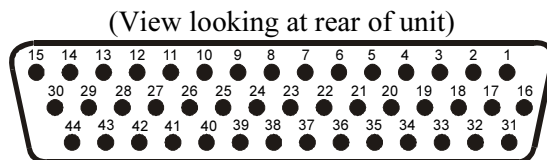

Pin	Pin Name	I/O
1	VOR/LOC +TO	Out
2	VOR/LOC +FROM (VOR/LOC COMMON)	Out
3	VOR/LOC +FLAG	Out
4	VOR/LOC -FLAG (VOR/LOC COMMON)	Out
5	VOR/LOC +LEFT	Out
6	VOR/LOC +RIGHT (VOR/LOC COMMON)	Out
7	RESERVED	--
8	VOR/LOC COMPOSITE OUT	Out
9	VOR OBS ROTOR C	Out
10	VOR OBS ROTOR H (GROUND)	Out
11	VOR OBS STATOR E/G (VOR/LOC COMMON)	In
12	VOR OBS STATOR F	In
13	VOR OBS STATOR D	In
14	PARALLEL DME - 8MHZ	Out
15	VOR/LOC SUPERFLAG	Out
16	500Ω VOR/ILS AUDIO HI	Out
17	500Ω VOR/ILS AUDIO LO	Out
18	SERIAL DME CLOCK	Out
19	SERIAL DME DATA	Out
20	SER DME - CHAN REQ/PAR DME - 4MHZ	I/O
21	SER DME - RNAV MODE/PAR DME - 2MHZ	I/O
22	DME COMMON	In
23	VOR/ILS ARINC 429 OUT B	Out
24	VOR/ILS ARINC 429 OUT A	Out
25	VOR OBI CLOCK	Out
26	VOR OBI SYNC	Out
27	VOR OBI DATA	Out
28	VLOC REMOTE TRANSFER	In
29	ILS ENERGIZE	Out
30	GLIDESLOPE +FLAG	Out
31	GLIDESLOPE +DOWN/-FLAG (GLIDESLOPE COMMON)	Out
32	GLIDESLOPE +UP	Out
33	PARALLEL DME - 1MHZ	Out
34	RESERVED	--
35	VOR/ILS ARINC 429 IN B	In
36	VOR/ILS ARINC 429 IN A	In
37	PARALLEL DME - 800KHZ	Out
38	GLIDESLOPE SUPERFLAG	Out
39	PARALLEL DME - 400KHZ	Out
40	PARALLEL DME - 200KHZ	Out
41	AIRCRAFT GROUND	--
42	PARALLEL DME - 100KHZ	Out
43	PARALLEL DME - 50KHZ	Out
44	AIRCRAFT POWER	In

4.2 Power, Lighting, and Antennas

This section covers the power input requirements, lighting bus input, and antenna connections. See Figure H-5 for interconnect information.

4.2.1 Power

Pin Name	Connector	Pin	I/O
AIRCRAFT POWER 1 (MAIN)	P4001	19	In
AIRCRAFT POWER 1 (MAIN)	P4001	20	In
AIRCRAFT POWER 2 (MAIN)	P4001	15	In
AIRCRAFT POWER 2 (MAIN)	P4001	72	In
AIRCRAFT POWER (COM)	P4002	11	In
AIRCRAFT POWER (COM)	P4002	12	In
AIRCRAFT POWER (NAV SUPERFLAG)	P4006	44	In
AIRCRAFT GROUND	P4001	77	--
AIRCRAFT GROUND	P4001	78	--
AIRCRAFT GROUND	P4002	21	--
AIRCRAFT GROUND	P4002	22	--
AIRCRAFT GROUND	P4006	41	--

CAUTION



To operate the COM transceiver in a 14 volt aircraft with a GNC 420AW, GNS 430AW or the 28 VDC upgrade units, (see Table 3-1), a 14 to 28 volt converter such as KGS Electronics model RB-126 or UC-14-28 or equivalent must be used. The voltage converter should include a single short circuit protection device on its output, such as a circuit breaker. The output should be connected to the COM power input, P4002-11 and P4002-12 for the COM transmitter. The other power input pins (P4001-19, -20, -15, -72 and P4006-44) accept 11 to 33 VDC. Refer to Figure H-5.

A power connection on P4006-44 is only required if NAV SUPERFLAG and/or G/S SUPERFLAG is utilized.

The power inputs P4001-19 and -20 provide power for all functions of the 400W Series unit except the COM transmitter and the NAV & G/S SUPERFLAG outputs.

4.2.2 Lighting Bus

Pin Name	Connector	Pin	I/O
LIGHTING BUS HI	P4001	39	In
LIGHTING BUS LO	P4001	40	In

The 400W Series unit can be configured to track 28 VDC, 14 VDC, 5 VDC or 5 Vac lighting buses using these inputs. Alternatively, the 400W Series unit can automatically adjust for ambient lighting conditions based on the photocell. Refer to Section 5.3.7 for configuring lighting inputs.

4.2.3 Antennas

Pin Name	Connector	I/O
GPS ANTENNA	P4003	In
COM ANTENNA	P4004	I/O
VOR/LOC ANTENNA	P4005	In
GLIDESLOPE ANTENNA	P4007	In

4.3 Altitude Gray Code

Altitude input is useful for advisory vertical navigation (VNAV) calculations.

Pin Name	Connector	Pin	I/O
ALTITUDE D4	P4001	70	In
ALTITUDE A1	P4001	69	In
ALTITUDE A2	P4001	68	In
ALTITUDE A4	P4001	67	In
ALTITUDE B1	P4001	66	In
ALTITUDE B2	P4001	65	In
ALTITUDE B4	P4001	64	In
ALTITUDE C1	P4001	63	In
ALTITUDE C2	P4001	62	In
ALTITUDE C4	P4001	61	In
ALTITUDE COMMON	P4001	60	In

These inputs are considered active if either the voltage to ground is <1.9 V or the resistance to ground is <375 Ω . These inputs are considered inactive if the voltage to ground is 11-33 VDC.

NOTE



Some transponders and other altitude encoder receivers do not have internal isolation diodes to prevent the unit from pulling the encoder lines to ground when the unit is off. These units require a diode added to the installation harness for each encoder line. The anode should be connected on the receiving unit's side and the cathode should be connected on the encoder side. A set of diodes is required for each unit without internal diodes. The 400W Series unit includes internal diodes for isolation of the encoder lines.

Refer to Section 5.3.9 for the gray code altitude checkout.

Refer to Figure H-6 for the gray code altitude interconnect.

4.4 Main Indicator

4.4.1 Main Indicator Function

The Main Indicator displays both lateral and vertical deviation from selected course, To/From indications, lateral and vertical flags and superflags.

The “CDI” key on the bezel of the GNS 430W takes the place of remote “NAV/GPS” switches, and is used to toggle between display of GPS and VOR/ILS navigation display on a remote indicator. The Navigation source is annunciated on the display above the ‘CDI’ key. The Navigation method is optionally annunciated externally by connecting to the VLOC ANNUNCIATE output (P4001-1) and GPS ANNUNCIATE output (P4001-2). GPS and VOR/ILS navigation may be toggled externally when the CDI SOURCE SELECT input (P4001-73) is momentarily grounded. See section 4.5 for more information on the external annunciators and switches.

An OBS resolver connection to the GPS is preferred, but not required. For the GNS 430W, an OBS resolver typically is connected to the MAIN OBS inputs for use with the GNS 430W VOR receiver.

4.4.2 Main Indicator Electrical Characteristics

4.4.2.1 Deviation

Pin Name	Connector	Pin	I/O
MAIN +LEFT	P4001	21	Out
MAIN +RIGHT (1.65V COMMON)	P4001	22	Out
MAIN +UP (1.65V COMMON)	P4001	27	Out
MAIN +DOWN	P4001	28	Out

The deviation output is capable of driving up to three 1000 Ω meter loads with ± 150 mVDC $\pm 10\%$ for full-scale deflection. The drive circuit provides for more than full-scale deflection with a maximum course deviation output voltage of ± 300 mVDC $\pm 10\%$.

4.4.2.2 TO/FROM

Pin Name	Connector	Pin	I/O
MAIN +TO (1.65V COMMON)	P4001	25	Out
MAIN +FROM	P4001	26	Out

The output is capable of driving up to three 200 Ω meter loads. When indicating TO, MAIN +TO is $+190 \pm 40$ mVDC with respect to MAIN +FROM. When indicating FROM, MAIN +TO is -190 ± 40 mVDC with respect to MAIN +FROM. When invalid information is present (Flag IN VIEW) the TO/FROM output is 0 ± 10 mVDC.

4.4.2.3 Flags

Pin Name	Connector	Pin	I/O
MAIN LATERAL +FLAG	P4001	23	Out
MAIN LATERAL -FLAG (GROUND)	P4001	24	Out
MAIN VERTICAL +FLAG	P4001	29	Out
MAIN VERTICAL -FLAG (GROUND)	P4001	30	Out

The Flag output is capable of driving up to three 1000 Ω meter loads. When valid information is present (Flag OUT OF VIEW) the Flag output is 375 ± 80 mVDC. When invalid information is present (Flag IN VIEW) the Flag will have an output is 0 ± 25 mVDC.

4.4.2.4 Superflags

Pin Name	Connector	Pin	I/O
MAIN LATERAL SUPERFLAG	P4001	17	Out
MAIN VERTICAL SUPERFLAG	P4001	18	Out

The output supplies not less than 500 mA on a 28 volt system and 250 mA on a 14 volt system with the output voltage not less than (AIRCRAFT POWER –1.5 VDC) when the flag is to be OUT OF VIEW. The output voltage with respect to ground is less than 0.25 VDC when the flag is to be IN VIEW.

4.4.2.5 OBS

Pin Name	Connector	Pin	I/O
MAIN OBS ROTOR C	P4001	31	Out
MAIN OBS ROTOR H (GROUND)	P4001	32	Out
MAIN OBS STATOR D	P4001	33	In
MAIN OBS STATOR E (2.5V COMMON OBS)	P4001	34	Out
MAIN OBS STATOR F	P4001	35	In
MAIN OBS STATOR G (2.5V COMMON OBS)	P4001	36	Out

MAIN OBS ROTOR C and H are a buffered output that is intended to drive the OBS rotors. MAIN OBS STATOR D and MAIN OBS STATOR F are each phase and amplitude shifted version of the MAIN ROTOR C output. Each pair is intended to read one of the two windings of the indicator's OBS stator.

4.4.3 Main Indicator Configuration

None.

4.4.4 Main Indicator Calibration and Checkout

Refer to Section 5.3.11 for the main CDI/OBS checkout.

4.4.5 Main Indicator Interconnect

Refer to Figure H-7 for the generic main indicator interconnect. Refer to Figure H-8 for the interconnect between a GNS 430W and a Bendix/King KI 209A. Refer to Figure H-9 for the interconnect between a GPS 400W or GNC 420W and a Bendix/King KI 208A.

4.5 Annunciators/Switches

4.5.1 Annunciators/Switches Function

NOTE



Installations in conformance with the requirements specified in this installation manual may not require the use of any external annunciators, since all annunciations are provided on the 400W Series front panel. Refer to Section 2.5.1 to determine whether or not external annunciators are required.

4.5.1.1 Message Annunciate

When a new status message is available, the Message Annunciator flashes. When status messages remain effective, the Message Annunciator illuminates.

4.5.1.2 Waypoint Annunciate

The waypoint annunciator output is driven in the following manner:

1. When the aircraft is within 10 seconds of reaching the turning point for a course change, the waypoint annunciator flashes.
2. When the aircraft is in a turn, the waypoint annunciator illuminates and remains illuminated until the turn is completed.
3. When a user arrival alarm is set and the aircraft is within the circle defined by the arrival alarm radius at the arrival waypoint, the waypoint annunciator flashes for 10 seconds.
4. When a user arrival alarm is not set and the aircraft is within 10 seconds of reaching the arrival waypoint, the waypoint annunciator flashes.

4.5.1.3 CDI SOURCE SELECT (GNS 430W Only)

This discrete input may be used to toggle between display of GPS and VOR/LOC/Glideslope information on the MAIN external CDI/HSI. A momentary low on this pin performs the same function as pressing the 'CDI' key on the GNS 430W bezel.

4.5.1.4 VLOC ANNUNCIATE (GNS 430W Only)

This annunciator output is driven when the unit is configured with a single CDI/HSI and the VOR/ILS data is being displayed on the CDI/HSI. This output parallels the VLOC annunciator on the display.

4.5.1.5 GPS ANNUNCIATE (GNS 430W Only)

This annunciator output is driven when the unit is configured with a single CDI/HSI and the GPS data is being displayed on the CDI/HSI. This output parallels the GPS annunciation on the display.

4.5.1.6 OBS MODE SELECT

This discrete input may be used to toggle between GPS OBS and GPS AUTO modes of operation. A momentary low on this pin performs the same function as pressing the 'OBS' key on the 400W Series unit.

4.5.1.7 OBS ANNUNCIATE

This annunciator output is driven to indicate GPS OBS mode of operation. This output is active when the OBS or SUSP annunciation is on the display.

4.5.1.8 TERMINAL ANNUNCIATE

When performing approach navigation, the terminal annunciator is illuminated when operating within 30 nautical miles of the departure or arrival airport and the CDI scale is the equivalent or 1.0 nm or less.

4.5.1.9 APPROACH ANNUNCIATE

When performing approach navigation, the approach annunciator illuminates when approach is active.

4.5.1.10 INTEGRITY ANNUNCIATE

The integrity annunciator illuminates when the GPS receiver detects a position error, or is unable to calculate the integrity of the position.

4.5.1.11 ILS/GPS APPROACH Output

The ILS/GPS Approach Output sinks 500 mA when:

- GPS navigation is selected and either a GPS approach mode is active or 0.3 nmi is selected for the CDI full scale deflection; or
- VLOC navigation is selected and an ILS channel has been selected.

This output may be connected to the ILS Engage input of an autopilot or flight director to provide higher autopilot gain while the 400W Series unit is operating in the ILS or GPS Approach modes of operation.

4.5.1.12 DEMO MODE SELECT

This discrete input may be used to select Demo Mode on the 400W Series unit. A low on this pin at time of unit power-up invokes the Demo Mode. Demo Mode allows the 400W Series unit to simulate reception of GPS satellite signals.



CAUTION

Do not connect DEMO MODE SELECT in an aircraft installation.

4.5.1.13 GPS SELECT

The GPS Select Output is driven low when GPS data is being displayed on the CDI/HSI and the ILS/GPS Approach Output is not active. It is intended for use with autopilots having a GPS Select input (such as the Bendix/King KAP 140 and KFC 225), so that the autopilot can capture vertical guidance while GPS data is being displayed on the CDI/HSI.

4.5.1.14 TIME MARK OUT

Time Mark Out is a time reference pulse output once per second, derived from GPS satellite signals.

4.5.1.15 ANNUNCIATE 'D' AND ANNUNCIATE 'E'

These annunciate outputs are used to control compatible traffic systems.

4.5.1.16 COM REMOTE RECALL (Main software version 3.00 or later)

This discrete input may be used to scroll through a list of preset COM frequencies. A momentary low on this pin will load the next preset frequency into the standby COM frequency.

4.5.2 Annunciators/Switches Electrical Characteristics

4.5.2.1 Annunciators

Pin Name	Connector	Pin	I/O
VLOC ANNUNCIATE	P4001	1	Out
GPS ANNUNCIATE	P4001	2	Out
WAYPOINT ANNUNCIATE	P4001	3	Out
TERMINAL ANNUNCIATE	P4001	4	Out
APPROACH ANNUNCIATE	P4001	5	Out
MESSAGE ANNUNCIATE	P4001	6	Out
OBS ANNUNCIATE	P4001	7	Out
AUTO ANNUNCIATE	P4001	8	Out
INTEGRITY ANNUNCIATE	P4001	9	Out
GPS SELECT [1]	P4001	13	Out
ILS/GPS APPROACH	P4001	14	Out

[1] The Operation of the GPS SELECT can be configured. Refer to Section 5.3.3.

All outputs sink up to 500 mA when activated.

4.5.2.2 Switch Inputs

Pin Name	Connector	Pin	I/O
OBS MODE SELECT	P4001	71	In
CDI SOURCE SELECT	P4001	73	In
COM REMOTE RECALL [1]	P4001	74	In
DEMO MODE SELECT	P4001	75	In

[1] Main software version 3.00 or later

These inputs are considered active if either the voltage to ground is < 1.9 V or the resistance to ground is $< 375 \Omega$. These inputs are considered inactive if the voltage to ground is 11-33 VDC.

4.5.2.3 TIME MARK OUT

Pin Name	Connector	Pin	I/O
TIME MARK OUT	P4001	16	Out

TIME MARK OUT outputs a $1 \text{ ms} \pm 1 \mu\text{s}$ wide pulse once every $1.0 \text{ s} \pm 2 \text{ ms}$. TIME MARK OUT is a logic level output, capable of sourcing 1 mA at greater than 3.8 V and sinking 1 mA at less than 0.4 V.

4.5.3 Annunciators/Switches Configuration

Refer to Section 5.3.3 for configuration of the GPS SELECT output.

4.5.4 Annunciators/Switches Calibration and Checkout

Refer to Section 5.3.9 for the annunciators/switches checkout.

4.5.5 Annunciators/Switches Interconnect

Refer to Appendix H for annunciators/switches interconnect information.

4.6 Serial Data

4.6.1 Serial Data Function

4.6.1.1 RS-232

The 400W Series unit is capable of interfacing with other aviation instruments by transmitting RS-232 Type 1 (often known as ARNAV format) and Type 2 (often known as Northstar format) data on the GPS RS-232 OUT 1 port. The data consists of the following (refer to Appendix D for a detailed data format description):

- Current latitude, longitude, and GPS altitude in feet (see Note below)
- Current velocity vector (ground speed and direction of velocity vector over the ground)
- Distance to waypoint
- Cross track error
- Desired track
- Destination waypoint identifier
- Bearing to destination waypoint
- Magnetic variation
- Navigation and warning status
- Waypoint sequence in route
- Waypoint position (latitude and longitude) and magnetic variation

NOTE



Aviation RS-232 data may be transmitted with or without the current GPS altitude in feet. Refer to Section 5.3.2.

The 400W Series unit can receive pressure altitude, air data, and fuel data from certain systems on the GPS RS-232 IN 1 port.

The 400W Series unit can communicate with a Ryan TCAD 9900B system using the GPS RS-232 OUT 2 and GPS RS-232 IN 2 lines to display traffic information on the 400W Series unit.

If two 400W or 500W Series units are installed in an aircraft, the GPS RS-232 OUT 3 and GPS RS-232 IN 3 lines may be cross-connected to crossfill flight plans and user-defined waypoints from one 400W or 500W Series unit to the other.

NOTE



The 400W Series unit will crossfill with other GNS 400W/500W Series units only. It will not crossfill with the GNS 480 or older GNS 400/500 Series units.

The 400W Series unit can communicate with an L3 Communications WX-500 Stormscope using the GPS RS-232 OUT 4 and GPS RS-232 IN 4 lines to display lightning strike information on the 400W Series unit.

4.6.1.2 ARINC 429

The data output on the GPS ARINC 429 OUT port depends on the configuration (see Section 5.3.1). Below is a list of the configurations and the labels output for each one:

1. ARINC 429
2. GAMA 429
3. GAMA 429 Graphics
4. GAMA 429 Graphics w/Int
5. GAMA 429 Pro Line 21
6. GAMA 429 Sextant
7. GAMA 429 Bendix King (*Main software version 3.00 or later*)

NOTE



Additional output settings may be available on units installed via OEM TC.

Label #	Parameter Name	1	2	3	4	5	6	7
001	Distance to Go (BCD)	•	•	•	•	•	•	•
002	Time to Go (BCD)	•	•	•	•	•	•	•
012	Ground Speed (BCD)	•	•	•	•	•	•	•
074G	Data Record Header		•	•	•	•	•	•
075G	Active Wpt From/To Data		•	•	•	•	•	•
100	Selected Course 1	•						
100P	Selected Course 1		•	•	•	•	•	•
113G	Message Checksum		•	•	•	•	•	•
114	Desired Track (True)	•	•	•	•	•	•	•
115	Waypoint Bearing (True)	•	•	•	•	•	•	•
116	Cross Track Distance	•						
116G [2]	Cross Track Distance		•	•	•	•	•	•
117G [1]	Vertical Deviation		•	•	•	•	•	
117P [1]	Vertical Deviation							•
121	Horizontal Command (to Autopilot)	•	•	•	•	•	•	•
125	Greenwich Mean Time (BCD)	•	•	•	•	•	•	•
147G	Magnetic Variation		•	•	•	•	•	•
251	Distance to Go	•						
251G	Distance to Go		•	•	•	•	•	•
252	Time to Go	•	•	•	•	•	•	•
260G	Date (BCD)		•	•	•	•	•	•
261G	GPS Discrete Word 1		•	•	•	•	•	•
275G	LRN Status Word		•	•	•	•	•	•
300G	Station Declination, Type, and Class		•	•	•	•	•	•
303	Message Length/Type/Number		•	•	•	•	•	•
304G	Message Characters 1-3		•	•	•	•	•	•
305G	Message Characters 4-6		•	•	•	•	•	•
306G	NAV/Waypoint/Airport Latitude		•	•	•	•	•	•
307G	NAV/Waypoint/Airport Longitude		•	•	•	•	•	•
310	Present Position Latitude	•	•	•	•	•	•	•
311	Present Position Longitude	•	•	•	•	•	•	•
312	Ground Speed	•	•	•	•	•	•	•
313	Track Angle (True)	•	•	•	•	•	•	•
314	True Heading	•	•	•	•	•	•	•
315	Wind Speed	•	•	•	•	•	•	•

Label #	Parameter Name	1	2	3	4	5	6	7
316	Wind Angle (True)	•	•	•	•	•	•	•
320	Magnetic Heading	•	•	•	•	•	•	•
321	Drift Angle	•	•	•	•	•	•	•
326G [2]	Lateral Scale Factor		•	•	•	•	•	•
327G [1]	Vertical Scale Factor		•	•	•	•	•	
330	Conic Arc Inbound Course			•	•			
331	Conic Arc Radius			•	•			
332	Conic Arc Course Change Angle			•	•			
333	Airport Runway Azimuth			•	•			
334	Airport Runway Length in Feet			•	•			
335	Left/Right Hand Holding Pattern Azimuth			•	•			
340	Left/Right Hand Procedure Turn Azimuth			•	•			
351G	Distance To Destination (Via Flight Plan)		•	•	•	•	•	•
352G	Estimated Time To Destination (Via Flight Plan)		•	•	•	•	•	•
371G	Specific Equipment ID		•	•	•	•	•	•
377	Equipment Hex ID Code	•	•	•	•	•	•	•

[1] Labels 117G/117P and 327G are not transmitted in the default configurations. There is a configuration setting that can be used to enable the transmission of these labels for the indicated ARINC 429 output types. Refer to Section 5.3.1 for additional details.

[2] Label 116G and 326G utilize the optional resolution extension bits (bits 11-13).

The following labels are output on the VOR/ILS ARINC 429 OUT port:

Label #	Parameter Name
034G	VOR/ILS Frequency (BCD)
035G	DME Frequency (BCD)
100G	Selected Course #1
173	Localizer Deviation
174	Glideslope Deviation
222	VOR Omnibearing
371G	Specific Equipment ID
377	Equipment Hex ID Code

The labels recognized on the GPS ARINC 429 IN 1 or GPS ARINC 429 IN 2 ports depend on the configuration (see Section 5.3.1).

The 400W Series unit can receive traffic data from a Garmin GTX 330 or an L3 Communications SKY497 SkyWatch system using the GPS ARINC 429 IN 1 or GPS ARINC 429 IN 2 ports, in order to display traffic information on the 400W Series unit.

4.6.2 Serial Data Electrical Characteristics

4.6.2.1 RS-232

Pin Name	Connector	Pin	I/O
GPS RS-232 OUT 1	P4001	56	Out
GPS RS-232 IN 1	P4001	57	In
GPS RS-232 OUT 2	P4001	58	Out
GPS RS-232 IN 2	P4001	59	In
GPS RS-232 OUT 3	P4001	41	Out
GPS RS-232 IN 3	P4001	42	In
GPS RS-232 OUT 4	P4001	54	Out
GPS RS-232 IN 4	P4001	55	In

The RS-232 outputs conform to EIA Standard RS-232C with an output voltage swing of at least ± 5 V when driving a standard RS-232 load.

4.6.2.2 ARINC 429

Pin Name	Connector	Pin	I/O
GPS ARINC 429 OUT A	P4001	46	Out
GPS ARINC 429 OUT B	P4001	47	Out
GPS ARINC 429 IN 1 A	P4001	48	In
GPS ARINC 429 IN 1 B	P4001	49	In
GPS ARINC 429 IN 2 A	P4001	50	In
GPS ARINC 429 IN 2 B	P4001	51	In
VOR/ILS ARINC 429 OUT A	P4006	24	Out
VOR/ILS ARINC 429 OUT B	P4006	23	Out
VOR/ILS ARINC 429 IN A	P4006	36	In
VOR/ILS ARINC 429 IN B	P4006	35	In

The GPS and VOR/ILS ARINC 429 outputs conform to ARINC 429 electrical specifications when loaded with up to 5 standard ARINC 429 receivers.

4.6.3 Serial Data Configuration

Refer to Section 5.3 for serial data configuration information.

4.6.4 Serial Data Calibration and Checkout

Refer to Section 5.3 and Section 5.5.6 for the serial data checkout information.

4.6.5 Serial Data Interconnects

Refer to for Appendix H for serial data interconnect information.

4.7 COM/VOR/ILS Audio (GNC 420W and GNS 430W only)

4.7.1 COM/VOR/ILS Audio Function

Activation of COM MIC KEY enables COM MIC AUDIO and causes the transceiver to transmit.

500 Ω COM AUDIO and 500 Ω VOR/ILS AUDIO are 100 mW audio outputs that are intended to drive a headset or an audio panel.

Momentarily depressing the COM REMOTE TRANSFER button toggles the active and standby COM frequencies. Momentarily depressing the VLOC REMOTE TRANSFER button toggles the active and standby VLOC frequencies.

The COM REMOTE TRANSFER input may be used for EMERGENCY operation of the COM transmitter. If the remote transfer switch is depressed for two seconds, the active COM frequency changes to 121.50 MHz. Once the emergency frequency is activated through COM REMOTE TRANSFER, GNS 430W and GNC 420W COM transceivers with COM software version 4.01 or later ignores inputs from the front panel controls for COM selections only. The pilot may exit this independent mode—restoring COM selection control to the front panel knobs and buttons—by momentarily depressing the COM REMOTE TRANSFER switch.

When TRANSMIT INTERLOCK is active, the GNC 420W or GNS 430W COM receiver sensitivity is decreased. This input is intended to reduce interference from other transmitters in the aircraft. The TRANSMIT INTERLOCK input should be connected to the PTT input of other transmitters in the aircraft. If connected to multiple PTT inputs, these connections must include diode isolation or multiple radios transmit simultaneously.

4.7.2 COM/VOR/ILS Audio Electrical Characteristics

4.7.2.1 COM MIC Key

Pin Name	Connector	Pin	I/O
COM MIC KEY	P4002	4	In

This input is considered active if either the voltage to ground is < 1.9 V or the resistance to ground is < 375 Ω . This input is considered inactive if the voltage to ground is 11-33 VDC.

4.7.2.2 COM MIC Audio, INTERCOM MIC Audio

Pin Name	Connector	Pin	I/O
COM MIC AUDIO HI	P4002	6	In
COM MIC AUDIO LO	P4002	18	In
INTERCOM MIC HI	P4002	5	In
INTERCOM MIC LO	P4002	17	In

COM MIC AUDIO and INTERCOM MIC each have a 520 Ω AC input impedance and supply the microphone with a 9 V bias through 620 Ω .

COM MIC AUDIO is set in the factory for 275 mVRMS to modulate the transmitter at 80% nominally. The microphone gain adjustment is made through Configuration Mode.

When a 125 mV_{RMS} signal at 1000 Hz is applied to the INTERCOM MIC input, the level on the COM AUDIO output is not less than 7.07 VRMS.

4.7.2.3 COM AUDIO, VOR/ILS AUDIO

Pin Name	Connector	Pin	I/O
500 Ω COM AUDIO HI	P4002	7	Out
500 Ω COM AUDIO LO	P4002	19	Out
500 Ω VOR/ILS AUDIO HI	P4006	16	Out
500 Ω VOR/ILS AUDIO LO	P4006	17	Out

500 Ω COM AUDIO and 500 Ω VOR/ILS AUDIO each supply 100 mW into a 500 Ω load. These are balanced outputs and the LO output must be connected.

500 Ω COM AUDIO is the summation of the COM receiver audio, COM sidetone audio, and INTERCOM MIC audio.

4.7.2.4 DISCRETE INPUTS

Pin Name	Connector	Pin	I/O
TRANSMIT INTERLOCK	P4002	14	In
COM REMOTE TRANSFER	P4002	15	In
VLOC REMOTE TRANSFER	P4006	28	In

These inputs are considered active if either the voltage to ground is < 1.9 V or the resistance to ground is < 375 Ω . These inputs are considered inactive if the voltage to ground is 11-33 VDC.

COM REMOTE TRANSFER and VLOC REMOTE TRANSFER are momentary inputs.

4.7.3 COM/VOR/ILS Audio Configuration

None.

4.7.4 COM/VOR/ILS Audio Calibration and Checkout

Refer to Section 5.3.12 for the COM calibration.

4.7.5 COM/VOR/ILS Audio Interconnect

Refer to Figure H-19 for the audio panel interconnect.

4.8 VOR/ILS Indicator (GNS 430W Only)

4.8.1 VOR/ILS Indicator Function

NOTE



Because the GNS 430W includes a “CDI” button that performs switching between GPS and VOR/ILS on a remote indicator, it is seldom necessary to use these outputs to drive an indicator. It is only necessary when it is desired for a separate indicator to display VOR/ILS deviation full-time (regardless of the “CDI” button status).

The VOR/ILS indicator displays both lateral and vertical, To/From indications, lateral and vertical flags and superflags. GNS 430W connector P4006 always outputs the VOR/Localizer/Glideslope navigation information. The VOR/ILS pins on GNS 430W connector P4006 are used to drive an indicator that displays VOR/ILS information at all times, regardless of the CDI selection on the GNS 430W.

VOR/LOC COMPOSITE OUT is a standard VOR/Localizer Composite output signal which may be used to drive the Left/Right, TO/FROM, and Flag indications of certain navigation indicators that contain an internal converter.

The ILS ENERGIZE output goes low when the VLOC frequency is channeled to a localizer channel.

4.8.2 VOR/ILS Indicator Electrical Characteristics

4.8.2.1 Superflags

Pin Name	Connector	Pin	I/O
VOR/LOC SUPERFLAG	P4006	15	Out
GLIDESLOPE SUPERFLAG	P4006	38	Out

The output supplies not less than 500 mA on a 28 volt system and 250 mA on a 14 volt system with the output voltage not less than (AIRCRAFT POWER - 3 VDC) when the flag is to be OUT OF VIEW. The output voltage with respect to ground is less than 3 VDC when the flag is to be IN VIEW.

4.8.2.2 Deviation

Pin Name	Connector	Pin	I/O
VOR/LOC +LEFT	P4006	5	Out
VOR/LOC +RIGHT (VOR/LOC COMMON)	P4006	6	Out
GLIDESLOPE +UP	P4006	32	Out
GLIDESLOPE +DOWN/-FLAG (GLIDESLOPE COMMON)	P4006	31	Out

The deviation outputs are each capable of driving up to three 1000 Ω meter loads with ± 150 mVDC $\pm 10\%$ with respect to 2.5V Common for full-scale deflection. The drive circuit provides for more than full-scale deflection with a maximum course deviation output voltage of ± 300 mVDC $\pm 10\%$.

4.8.2.3 TO/FROM

Pin Name	Connector	Pin	I/O
VOR/LOC +TO	P4006	1	Out
VOR/LOC +FROM (VOR/LOC COMMON)	P4006	2	Out

The output is capable of driving up to three 200 Ω meter loads. When indicating TO, the output is $+225 \pm 75$ mVDC. When indicating FROM, output is -225 ± 75 mVDC. When invalid information is present (Flag IN VIEW) the TO/FROM output is 0 ± 10 mVDC.

4.8.2.4 Flag

Pin Name	Connector	Pin	I/O
VOR/LOC +FLAG	P4006	3	Out
VOR/LOC -FLAG (VOR/LOC COMMON)	P4006	4	Out
GLIDESLOPE +FLAG	P4006	30	Out
GLIDESLOPE +DOWN/-FLAG (GLIDESLOPE COMMON)	P4006	31	Out

The Flag output is capable of driving up to three 1000 Ω meter loads. When valid information is present (Flag OUT OF VIEW) the Flag output is 375 \pm 80 mVDC. When invalid information is present (Flag IN VIEW) the Flag output is 0 \pm 25 mVDC.

4.8.2.5 OBS

Pin Name	Connector	Pin	I/O
VOR OBS ROTOR C	P4006	9	Out
VOR OBS ROTOR H (GROUND)	P4006	10	Out
VOR OBS STATOR D	P4006	13	In
VOR OBS STATOR F	P4006	12	In
VOR OBS STATOR E/G (VOR/LOC COMMON)	P4006	11	Out

VOR OBS ROTOR C and H are a buffered 500 Hz output that is intended to drive the OBS rotors. VOR OBS STATOR D and VOR OBS STATOR F are each phase and amplitude shifted version of the VOR ROTOR C output. Each pair is intended to read one of the two windings of the indicator's OBS stator.

4.8.2.6 VOR/LOC COMPOSITE

Pin Name	Connector	Pin	I/O
VOR/LOC COMPOSITE OUT	P4006	8	Out

With a Standard VOR Test Signal applied, VOR/LOC COMPOSITE OUT is 0.5 \pm 0.1 VRMS into a 10 k Ω load. With a Standard Localizer Centering Test Signal applied, VOR/LOC COMPOSITE OUT is 0.350 \pm 0.05 VRMS into a 10 k Ω load.

4.8.2.7 ILS ENERGIZE

Pin Name	Connector	Pin	I/O
ILS ENERGIZE	P4006	29	Out

The driver output voltage is not more than 1.0 V when sinking 20 mA. The maximum off state leakage current with respect to GND is less than 10 μ A.

4.8.3 VOR/ILS Indicator Configuration

None.

4.8.4 VOR/ILS Indicator Calibration and Checkout

Refer to Sections 5.3.14 and 5.3.15 for the VOR/LOC/GS checkout.

4.8.5 VOR/ILS Indicator Interconnect

Refer to Figure H-20 for the VOR/ILS indicator interconnect.

4.9 RMI/OBI

4.9.1 RMI/OBI Function

The MAIN OBI output provides bearing information from the active waypoint for Bendix/King Serial OBI devices based upon the 400W Series unit's GPS navigation. For the GNS 430W, the MAIN OBI output may be configured so that it sends VOR/ILS bearing information when VLOC is selected by the GNS 430W CDI key.

The VOR OBI output provides bearing information from the currently tuned VOR station for Bendix/King Serial OBI devices based upon the GNS 430W VOR receiver. When a localizer channel is tuned on the VLOC window, there is a bit in the data stream set to indicate that a localizer frequency is tuned which stows the needle or drives it to the 3 o'clock position.

4.9.2 RMI/OBI Electrical Characteristics

Pin Name	Connector	Pin	I/O
MAIN OBI CLOCK	P4001	43	Out
MAIN OBI SYNC	P4001	45	Out
MAIN OBI DATA	P4001	44	Out

Pin Name	Connector	Pin	I/O
VOR OBI CLOCK	P4006	25	Out
VOR OBI SYNC	P4006	26	Out
VOR OBI DATA	P4006	27	Out

The output driver is active low. The driver output voltage is not more than 1.0 V when sinking 20 mA. The maximum off state leakage current with respect to ground is less than 10 μ A.

4.9.3 RMI/OBI Configuration

For the GNS 430W, refer to Section 5.3.11 for the MAIN OBI source configuration.

4.9.4 RMI/OBI Calibration and Checkout

Refer to Section 5.5.6.11 for calibration and checkout.

4.9.5 RMI/OBI Interconnect

Refer to Figure H-21 for the RMI/OBI interconnect.

4.10 DME Tuning (GNS 430W Only)

4.10.1 DME Tuning Function

The GNS 430W can channel a DME based on the tuned VLOC frequency. The GNS 430W outputs 2 of 5, BCD or Slip parallel DME and King Serial DME channeling format. When DME COMMON is held low, the GNS 430W actively tunes the DME.

4.10.2 DME Tuning Electrical Characteristics

4.10.2.1 Parallel DME Tuning

Pin Name	Connector	Pin	I/O
NAV PAR DME - 8MHZ	P4006	14	Out
SER DME – CHAN REQ/PAR DME – 4 MHz	P4006	20	Out*
SER DME – RNAV MODE/PAR DME – 2 MHz	P4006	21	Out*
NAV PAR DME – 1 MHz	P4006	33	Out
NAV PAR DME – 800 kHz	P4006	37	Out
NAV PAR DME – 400 kHz	P4006	39	Out
NAV PAR DME – 200 kHz	P4006	40	Out
NAV PAR DME – 100 kHz	P4006	42	Out
NAV PAR DME – 50 kHz	P4006	43	Out
NAV DME COMMON	P4006	22	In

* These pins are outputs when the GNS 430W is configured for 2 of 5 parallel DME tuning.

For each of the parallel DME tuning discrete outputs, the driver output voltage is not more than 1.0 V while sinking 20 mA. The maximum off state leakage current with respect to ground is less than 10 μ A.

NAV DME COMMON must be pulled low to indicate to the NAV module that it is the device channeling the DME.

NAV DME COMMON is considered active if either the voltage to ground is < 1.9 V or the resistance to ground is < 375 Ω . These inputs are considered inactive if the voltage to ground is 11-33 VDC.

4.10.2.2 King Serial DME Tuning

Pin Name	Connector	Pin	I/O
NAV SER DME - DATA	P4006	19	Out
NAV SER DME - CLOCK	P4006	18	Out
SER DME – CHAN REQ/PAR DME - 4MHZ	P4006	20	In*
SER DME – RNAV MODE/PAR DME – 2MHZ	P4006	21	In*
NAV DME COMMON	P4006	22	In

* These pins are inputs when the GNS 430W is configured for King Serial DME tuning

When NAV SER DME – DATA or NAV SER DME – CLOCK is asserted high and driving a 360 Ω load, the driver output voltage is not less than 8 V, and when asserted low shall not be greater than 10 mV.

SER DME – CHAN REQ/PAR DME – 4MHZ, SER DME – RNAV MODE/PAR DME – 2MHZ, and NAV DME COMMON are considered active if either the voltage to ground is < 1.9 V or the resistance to ground is < 375 Ω . These inputs are considered inactive if the voltage to ground is 11-33 VDC.

NAV DME COMMON must be pulled low to indicate to the NAV module that it is the device channeling the DME.

4.10.3 DME Tuning Configuration

Refer to Section 5.3.14 for the DME tuning configuration.

4.10.4 DME Tuning Calibration and Checkout

None.

4.10.5 DME Tuning Interconnect References

Refer to Appendix H for interconnect information.

NOTE



For the GNS 430W to tune a Narco DME 890 or IDME 891 or an ARC (Cessna) RTA-476A using parallel 2 of 5, unique wiring and configuration are required. Refer to 5.3.14 and Figure H-24.

5. POST INSTALLATION CONFIGURATION & CHECKOUT PROCEDURES

Once the 400W Series unit has been installed, configure the unit for the particular installation and then complete the checkout procedures herein to verify proper operation. The steps that are not applicable to a particular installation may be skipped. A checkout log is included in **Table 5-1** at the end of this section and is to be filled out during the checkout procedures. The completed checkout log sheet should be maintained with the aircraft permanent records.

5.1 Mounting and Wiring Check

Verify that all cables are properly secured and shields are connected as the install drawings indicate. Installation may require that you check the movement of the aircraft controls to verify that there is no interference.

5.2 Connector Engagement Check

Prior to the configuration and checkout of the 400W Series unit the connector engagement should be checked as described below:

1. Turn on the 400W Series unit, and turn on the avionics master switch (if applicable).
2. Place the 400W Series unit in the rack and engage the pawl mechanism.
3. Turn the Allen screw of the locking pawl slowly clockwise until the 400W Series unit just comes on. A “T” handle makes the turns easy to count, but do not over-tighten.
4. Count the number of complete revolutions you can turn the Allen screw until it can not turn any more (but take care not to over-tighten). Three turns is the minimum for proper installation. If fewer than three turns are possible, the mounting rack should be moved aft (toward the pilot) such that the aircraft panel does not obstruct the unit from engaging in the rack.

5.3 Configuration Mode Operations

With power applied to the aviation rack and the 400W Series unit turned off, press and hold the ENT key and turn the unit on. Release the ENT key when the display activates. After the Data Base and Instrument Panel Self-test pages, the first page displayed is the MAIN ARINC 429 CONFIG page. While in Configuration Mode, pages can be selected by ensuring the cursor is off and rotating the small right knob.

To change data on the displayed Configuration Page, press the small right knob (CRSR) to turn on the cursor. Rotate the large right knob to change between data fields. Rotate the small right knob to change a field that the cursor is on. Once you have made the desired selection, press the ENT key to accept the entry.

The Configuration Pages described in the following sections are in the order found when rotating the right small knob clockwise starting at the MAIN ARINC 429 CONFIG page.

NOTE



The configuration pages shown here reflect main software version 3.20. Some differences in operation may be observed when comparing the information in this manual to later software versions. All configuration pages shown apply to the GNS 430W, but not all apply to the GPS 400W or GNC 420W. Those pages and fields that apply only to certain 400W Series units are denoted as such.

NOTE



If any changes made in configuration mode are done on ARINC 429 or RS-232 pages, the unit must be reset for the changes to take effect. This is accomplished by powering the unit off and then back on.

5.3.1 MAIN ARINC 429 CONFIG Page

Select the MAIN ARINC 429 CONFIG Page (see Figure 5-1). This page configures the GPS ARINC 429 output port, and the two GPS ARINC 429 input ports. The two input ports can each be configured independently for the desired function(s).



Figure 5-1. MAIN ARINC 429 CONFIG Page

SPEED

Selection	Description
Low	Standard low-speed ARINC 429 (nominally 12.5 kilobits per second)
High	High-speed ARINC 429 (nominally 100 kilobits per second)

NOTE



Interfacing systems listed in the following tables are provided for reference only. Refer to Appendix G to determine if the interface to a particular system is approved under the 400W/500W Series AML STC.

DATA IN 1, DATA IN 2

Selection	Description
Off	No unit connected to this ARINC 429 input
Airdata	Altitude, temperature, and speed information from the following Air Data systems: <i>B & D 2600, 2601, 2800, 90004-003</i> <i>Bendix/King KAD 280/480, Shadin ADC 2000</i>
Airdata/AHRS	Heading, altitude, temperature, and speed information from an Air Data/AHRS system.
EFIS	Selected course, heading, and joystick waypoint information from the following EFIS systems: <i>Bendix/King EFS 40/50</i> <i>Certain versions of Collins EFIS may also be compatible with this format.</i>
EFIS/Airdata	Selected course, heading, joystick waypoint, altitude, temperature, and speed information from the following systems: <i>Collins Pro Line 21</i> <i>Bendix/King EFS 40/50 (with SW 1201 or later)</i>
Flight Control	Selected course information from the following Flight Control systems: <i>Bendix/King KFC 400</i>
Garmin GAD 42	Selected course, heading, and true airspeed data from the Garmin GAD 42.
Garmin GDU [1]	Selected course, heading, altitude, temperature and speed information from the following systems: <i>Garmin G600</i>
Garmin GTX 330	Garmin and Garmin w/TIS This is a Garmin data concentration format. Only high speed ARINC 429 should be used. <i>Garmin GTX 330</i>
Honeywell EFIS	Selected course, heading, and joystick waypoint information from the following EFIS systems: <i>Honeywell Primus 1000</i>
INS/IRU	Heading information from the following Inertial systems: <i>Bendix/King KAH 460</i> <i>Collins AHC 85</i> <i>Honeywell Laseref</i> <i>Litef LTR 81</i> <i>Litton LTN 90-100, LTN 91, LTN 92</i>
RADAR Graphics	Joystick waypoint information from a RADAR graphics unit.
Sandel EHSI	Selected course and heading information from the following EHSI system: <i>Sandel SN3308</i> <i>Sandel SN3500</i>
Traffic Advisory	Traffic information from the following traffic advisory systems: <i>L3 Communications SKY497 SkyWatch</i> <i>L3 Communications SKY899 SkyWatch HP</i> <i>Bendix/King KTA-870, KMH880</i>

[1] Main software version 3.10 or later

DATA OUT

NOTE



Additional output settings may be available on units installed via OEM TC.

Selection [2]	Description
Off	No unit(s) connected to ARINC 429 output
ARINC 429	Standard ARINC 429 output data (non-GAMA).
GAMA 429	ARINC 429 data as defined by the <i>General Aviation Manufacturers' Association (GAMA) General Aviation Subset, 2nd Edition</i> . The output data includes navigation and flight plan information to the following systems: <i>Garmin GAD 42 Interface Adapter</i> <i>Bendix/King EFS 40/50</i> (No GPS vertical guidance provided) <i>Collins EFIS 84</i> Certain other versions of Collins EFIS may also be compatible with this format.
GAMA 429 Bendix King [1]	ARINC 429 data as defined by the <i>GAMA General Aviation Subset, 2nd Edition</i> . The output data includes navigation, flight plan and GPS vertical guidance information to the following systems: <i>Bendix/King EFS 40/50</i> (GPS vertical guidance provided on EFIS)
GAMA 429 Graphics	ARINC 429 data as defined by the <i>GAMA General Aviation Subset, 2nd Edition</i> including GAMA Graphics Protocol 'A'. This format outputs intersection symbols as generic waypoint symbols. The output data includes navigation and flight plan information (including graphical representation of flight plan procedures) to the following EFIS systems: <i>Honeywell Primus 1000</i>
GAMA 429 Graphics w/Int	ARINC 429 data as defined by the <i>GAMA General Aviation Subset, 2nd Edition</i> including GAMA Graphics Protocol 'A'. The output data includes navigation and flight plan information (including graphical representation of flight plan procedures) to the following systems: <i>Sandel SN3308</i> <i>Sandel SN3500</i>
GAMA 429 Pro Line 21	ARINC 429 data as defined by the <i>GAMA General Aviation Subset, 2nd Edition</i> . The output data includes navigation and flight plan information to the following EFIS systems: <i>Collins Pro Line 21</i>
GAMA 429 Sextant	ARINC 429 data as defined by the <i>GAMA General Aviation Subset, 2nd Edition</i> . The output data includes navigation and flight plan information to the following EFIS systems: <i>Sextant SMD 45</i>

[1] Main software version 3.00 or later

[2] Garmin GTX 330 will work with any output setting

SDI

Selection	Description
Common	RX: Accepts all 429 inputs TX: Generates all 429 outputs with SDI = 0.
LNAV 1	Number 1 (Pilot) long-range navigator RX: Accepts 429 inputs with SDI = 0 or 1. TX: Generates all 429 outputs with SDI = 1.
LNAV 2	Number 2 (Copilot) long-range navigator RX: Accepts 429 inputs with SDI = 0 or 2. TX: Generates all 429 outputs with SDI = 2.

VNAV

Selection	Description
Disable Labels	ARINC 429 labels associated with GPS-based vertical guidance (labels 117G and 327G) are not transmitted in the output data stream.
Enable Labels	ARINC 429 labels associated with GPS-based vertical guidance (labels 117G and 327G) are transmitted in the output data stream. ARINC 429 vertical guidance labels are used by the following systems: <i>Sandel SN3500</i> Other systems may also use these labels.

5.3.2 MAIN RS-232 CONFIG Page

Select the MAIN RS-232 CONFIG Page (see Figure 5-2). Change the selectable RS-232 inputs and/or outputs to match that of the equipment installed in the aircraft.

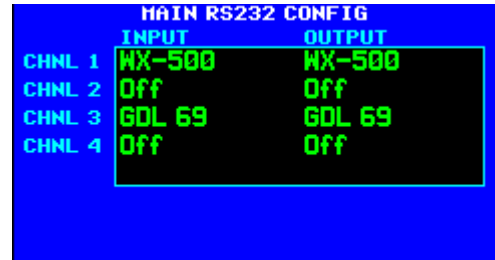

Figure 5-2. MAIN RS-232 CONFIG Page

NOTE



Interfacing systems listed in the following tables are provided for reference only. Refer to Appendix G to determine if the interface to a particular system is approved under the 400W/500W Series AML STC.

CHANNEL INPUTS

Selection	Description
Off	No unit(s) connected to input of this channel.
Arnav/ei-fuel	Serial fuel flow information from the following units: <i>ARNAV FC-10, FT-10</i> <i>Electronics International FP-5L</i>
Crossfill	Serial transfer of flight plans and user waypoints between two 400W/500W Series units
GDL 69	Serial data input for in-flight access to weather and messaging from the following units: <i>Garmin GDL 69/69A</i>
Icarus-alt	Serial altitude data from the following units: <i>Icarus Instruments 3000</i> <i>Sandia SAE5-35</i> <i>Garmin GTX 327 Transponder</i> <i>Trans-Cal Industries IA-RS232-X, SSD120</i> <i>ACK Technologies A-30 (Mod 8 and above)</i>
Ryan TCAD	Traffic information from a Ryan TCAD 9900B or 9900BX Series system.
Shadin-adc	Serial air data information from the following units: <i>Shadin ADC 200, 200+, 2000</i>
Shadin-alt	Serial altitude data from the following units: <i>Shadin 8800T, 9000T, 9200T</i>
Shadin-fadc	Serial air data and fuel flow information from the following units: <i>Shadin 9628XX-X Fuel/Air Data Computer</i> <i>INSIGHT TAS 1000 Air Data Computer</i>
Shadin-fuel	Serial fuel flow information from the following units: <i>Shadin 91053XM Digital Fuel Management System</i> <i>Shadin 91204XM Digital Fuel Management System</i> <i>JP Instruments EDM-700 or EDM-760 Engine Monitor</i>
WX-500	Lightning strike information from an L3 Communications WX-500 Stormscope.

CHANNEL OUTPUTS

Selection	Description
Off	No unit(s) connected to output of this channel
ADS-B OUT	Serial communication to Garmin GTX 33/330 ES or 33D/330D ES Transponders. [4]
Aviation	Serial position, altitude, velocity, and navigation data to the following units: <i>Argus 3000, 5000, or 7000 Moving Map</i> <i>Electronics International FP-5L Fuel Flow Computer (non-TSO'd)</i> <i>Garmin MX20 (V5.6 or later), GMX 200 [1]</i> <i>Garmin GPSMAP 195, GPSMAP 295 or GPS III Pilot</i> <i>Garmin GPSMAP 196, GPSMAP 296, and GPSMAP 396</i> <i>Garmin GTX 327 Transponder</i> <i>JP Instruments EDM-700 or EDM-760 Engine Monitor</i> <i>Shadin 91204XM Digital Fuel Management System</i> <i>Shadin 91053XM Digital Fuel Management System</i> <i>Shadin 9628XX-X Fuel/Air Data Computer</i> <i>Stormscope Series II (with NAVAID) Moving Map</i>
Avtn no alt	Serial position, velocity, and navigation data to the following units: <i>Garmin MX20 (V5.5 or earlier)</i> <i>Horizon DDMP</i> <i>INSIGHT TAS 1000 Air Data Computer</i>
Crossfill	Serial transfer of flight plans and user waypoints between two 400W/500W Series units
GDL 69	Serial communication to a Garmin GDL 69/69A.
HW EGPWS [3]	Serial communication to a Bendix/King (Honeywell) KGP 560 EGPWS.
MapMX [2] [3]	Serial position, altitude, velocity, and navigation data to the following units: <i>Garmin MX20 (V5.7 or later), GMX 200 [2]</i>
Ryan TCAD	Serial communication with a Ryan TCAD 9900B Series system.
WX-500	Serial communication to an L3 Communications WX-500 Stormscope.

- [1] The MX20 will not use GPS altitude from the 400W Series unit. The GMX200 will use the GPS altitude.
- [2] Use of the MapMX protocol supports enhanced flight plan depiction and automatic loading of charts on the MX20 and GMX 200. MapMX is only available with main software version 3.10 or later.
- [3] Due to hardware limitations, selecting MapMX or HW EGPWS on an RS-232 output port prevents anything from being configured on the corresponding input port.
- [4] ADS-B OUT is only available with main software version 3.20 or later.

5.3.3 MAIN SYSTEM CONFIG

Select the MAIN SYSTEM CONFIG Page (see Figure 5-3). This page allows you to configure the Fuel, Terrain, and Discretes options.

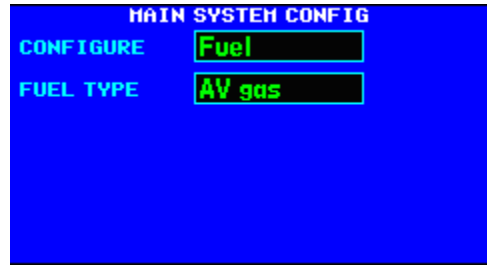

Figure 5-3. MAIN SYSTEM CONFIG Page

Fuel

Select **Fuel** in the **CONFIGURE** field to select the FUEL TYPE (**AV Gas**, **Jet A**, or **Jet B**)

Selection	Description
AV gas	The aircraft is using Aviation gas (5.8 lbs./gal.)
Jet A	The aircraft is using Jet A or Jet A-1 fuel (6.7 lbs./gal.)
Jet B	The aircraft is using Jet B (JP-4) fuel (6.5 lbs./gal.)

Terrain

Select **Terrain** in the **CONFIGURE** field to select the TERRAIN TYPE (**NONE** or **TERRAIN**).

To test the Terrain Data Card, highlight the **TEST CARD** field and press the ENT key. Verify that the **TEST CARD** field indicates "PASS". A "FAIL" condition indicates that the Terrain Data Card is unusable.

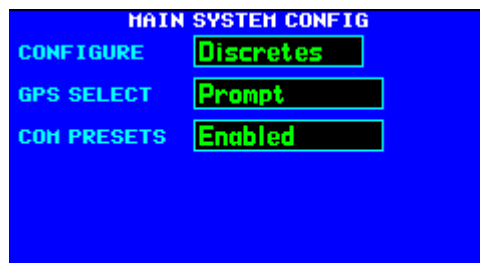

Figure 5-4. MAIN SYSTEM CONFIG Page

Selection	Description
None	No terrain functionality.
TERRAIN	The unit is configured for TERRAIN capability.

Discretes

Select **Discretes** in the **CONFIGURE** field to configure the operation of specific discrete outputs.



GPS Select

Figure 5-5. MAIN SYSTEM CONFIG Page

Selection	Description
Auto	When in GPS mode, the GPS Select discrete is unasserted (open) whenever a GPS approach mode is active – no associated messages appear and no pilot action is required. The pilot is also allowed to select automatic or manual GPS to ILS CDI transitions on the AUX CDI/ALARMS page.
Prompt	When in GPS mode, the GPS Select discrete is unasserted (open) whenever a GPS approach mode is active and the pilot has enabled the A/P APR Outputs (an associated message is displayed telling the pilot to enable the A/P APR Outputs). This setting will not allow the pilot to select automatic GPS to ILS CDI transitions on the AUX CDI/ALARMS page (only manual transitions are permitted). <i>For Honeywell (Bendix/King) KFC 225 and KAP 140 autopilots.</i>

NOTE



The GPS SELECT setting affects autopilot mode transitions and must be reflected in the AFMS. Refer to Section 5.8 for details.

COM Presets (Main software version 3.00 or later)

Selection	Description
Disabled	The COM Configuration Aux page is not available to the pilot.
Enabled	The COM Remote Recall discrete input is connected in the installation (refer to 4.5.1.16 for additional details). When COM presets are enabled, the user is able to preset COM frequencies and load them into the standby COM frequency using a remote switch.

5.3.4 MAIN INPUTS 1 Page

Select the MAIN INPUTS 1 Page (see Figure 5-6). This page (along with the MAIN INPUTS 2 Page) allows you to monitor the data on ARINC 429, RS-232 and other electrical inputs. This is used for verifying electrical interfaces during installation and troubleshooting. Information that is not being received by the 400W Series unit is dashed out.

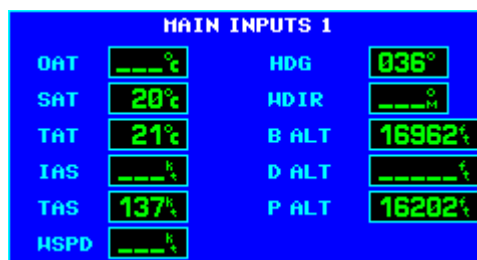

Figure 5-6. MAIN INPUTS 1 Page

Field	Description
OAT	Outside Air Temperature
SAT	Static Air Temperature
TAT	Total Air Temperature
IAS	Indicated Airspeed
TAS	True Airspeed
WSPD	Wind Speed
HDG	Heading (True or Magnetic)
WDIR	Wind Direction
B ALT	Barometric-corrected Altitude
D ALT	Density Altitude
P ALT	Pressure Altitude

5.3.5 MAIN INPUTS 2 Page

Select the MAIN INPUTS 2 Page (Figure 5-7). This page is also used for verifying electrical interfaces during installation and troubleshooting. Information that is not being received by the 400W Series unit is dashed out.



Figure 5-7. MAIN INPUTS 2 Page

Field	Description
L FF	Left Engine Fuel Flow
R FF	Right Engine Fuel Flow
T FF	Total Fuel Flow
T FOB	Total Fuel on Board
GPS SC	GPS Selected Course
VLC SC	VOR/LOC Selected Course (GNS 430W Only)
JOYSTICK WPT	Latitude and longitude of a joystick waypoint sent by an EFIS or RADAR indicator.
CDI	Status of the CDI key (GNS 430W Only)

5.3.6 INSTRUMENT PANEL SELF-TEST Page

Select the INSTRUMENT PANEL SELF-TEST Page (see Figure 5-8). This page allows verification that the 400W Series unit is communicating properly with other instruments. Compare on-screen indications with the information depicted on connected instruments, such as the CDI, HSI, RMI and/or external annunciators. It also displays fuel capacity, amount on-board, and flow.

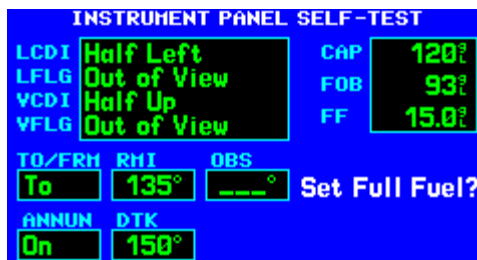

Figure 5-8. INSTRUMENT PANEL SELF-TEST Page

5.3.7 MAIN LIGHTING Page

Select the MAIN LIGHTING Page (see Figure 5-9). This page allows you to set display parameters that affect the display backlight and key lighting brightness. The DISPLAY and KEY lighting characteristics are adjusted separately, each with the following fields:



Figure 5-9. MAIN LIGHTING Page

LIGHTING

Shows the current level of display backlighting, based on the lighting input source (lighting bus voltage, or the ambient light if the source is **PHOTO**) and the settings on this configuration page. This field has a range of 0 (zero) to 9999.

SOURCE

Selection	Description
PHOTO	Backlight level is determined by the ambient light level as measured by the photocell on the 400W Series unit.
14V DC	Backlight level tracks a 14 volt DC aircraft lighting bus.
28V DC	Backlight level tracks a 28 volt DC aircraft lighting bus.
5V DC	Backlight level tracks a 5 volt DC aircraft lighting bus.
5V AC	Backlight level tracks a 5 volt AC aircraft lighting bus.

RESP TIME - (Response Time)

Sets the speed with which the brightness responds to the input level (bus voltage or ambient light) changes. The higher the number the slower the display responds. This field has a range of 3 to 7, and is set to 4 at the factory.

MIN - (Minimum)

Sets the minimum brightness of the display. The higher the number, the brighter the minimum brightness. Display minimum brightness has a range of 35 to 999, and is set to 80 at the factory. Key minimum brightness has a range of 20 to 99, and is set to 40 at the factory. It is prudent to verify that display and key lighting characteristics match those of other equipment in the panel under night lighting conditions.

SLOPE

Sets the sensitivity of the display brightness in proportion to changes in the input level. The higher the number, the brighter the display is for a given increase in the input level. This field has a range of 0 (zero) to 99, and is set to 50 at the factory.

OFFSET

Adjusts the lighting level up or down for any given input level. This field has a range of 0 (zero) to 99, and is set to 50 at the factory. This may also be used to match lighting curves with other equipment in the panel.

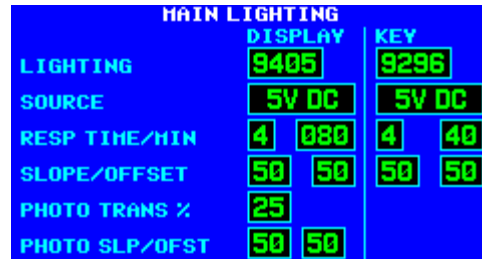

MAIN LIGHTING				
	DISPLAY		KEY	
LIGHTING	9405		9296	
SOURCE	5V DC		5V DC	
RESP TIME/MIN	4	080	4	40
SLOPE/OFFSET	50	50	50	50
PHOTO TRANS %	25			
PHOTO SLP/OFFST	50	50		

Figure 5-10. MAIN LIGHTING Page
(Display Lighting from Lighting Bus)

NOTE



If a lighting bus (any selection other than **PHOTO**) is selected, and the lighting bus control is turned to its minimum (daytime) setting, the display brightness tracks the 400W Series unit's photocell using additional parameters (PHOTO TRANS % and PHOTO SLP/OFFST) described below.

PHOTO TRANS % - (Photocell Transition Percentage) When a lighting bus is used to control the lighting of the display (see Figure 5-10), this parameter sets the point on the lighting bus control below which the display brightness tracks the 400W Series unit's photocell. This field has a range of 0 (zero) to 99, and is set to 25 at the factory.

PHOTO SLP/OFFST - (Photocell Slope/Offset)

These fields are equivalent to the SLOPE/OFFSET fields described above, with the exception that they only control the display lighting characteristics when the lighting bus control is below the level specified in the PHOTO TRANS % field. Both fields have a range of 0 (zero) to 99, and are set to 50 at the factory.

5.3.8 GPS DATE/TIME SETUP Page

This page displays the GPS date and time. (see Figure 5-11).



GPS DATE / TIME	
UTC DATE	UTC TIME
04-FEB-06	19:41:40

Figure 5-11. DATE/TIME SETUP Page

5.3.9 MAIN DISCRETE INPUTS Page

Select the MAIN DISCRETE INPUTS Page (see Figure 5-12) if the encoding altimeter input is used. Verify that the **DECODED ALTITUDE** field indicates the correct altitude.

GRAY CODE

If the encoding altimeter input is used, verify that the **DECODED ALTITUDE** field indicates the correct altitude.

EXTERNAL SWITCH STATE

This allows you to verify the operation of any external switches that are present in the installation.



Figure 5-12. MAIN DISCRETE INPUTS Page

Selection	Verify That:
RMT OBS	The box is filled in while a remote OBS switch is pressed.
RMT CDI	The box is filled in while a remote CDI source select switch is pressed.
RMT RCL [1]	The box is filled in while the COM remote recall switch is pressed.

[1] Main software version 3.00 or later

5.3.10 MAIN DISCRETE OUTPUTS Page

Select the MAIN DISCRETE OUTPUTS Page (see Figure 5-13). This page allows you to verify the operation of any external annunciators and switches that are present in the installation.



Figure 5-13. MAIN DISCRETE OUTPUTS Page

DISCRETE TOGGLE

Selection	Verify That:
APR	The APR annunciator is active and inactive as selected on this page.
GPS	The GPS source select annunciator is active and inactive as selected on this page.
INTEG	The INTEG annunciator is active and inactive as selected on this page.
MSG	The MSG annunciator is active and inactive as selected on this page.
OBS	The OBS annunciator is active and inactive as selected on this page.
TERM	The TERM annunciator is active and inactive as selected on this page.
VLOC	The VLOC source select annunciator is active and inactive as selected on this page.
WPT	The WPT annunciator is active and inactive as selected on this page.
ILS/GPS APR	The ILS/GPS APPROACH output is active and inactive as selected on this page (NOTE: This output is connected to the autopilot ILS ENGAGE input, not to an annunciation, and therefore this is for bench testing purposes only).
GPS SELECT	The GPS SELECT output is active and inactive as selected on this page (NOTE: This output is connected to the autopilot GPS SELECT input, not to an annunciation, and therefore this is for bench testing purposes only).

5.3.11 MAIN CDI/OBS CONFIG Page

Select the MAIN CDI/OBS CONFIG Page (see Figure 5-14). This page allows you to verify the MAIN CDI outputs, both lateral (LAT) and vertical (VERT), and verify and calibrate the MAIN OBS input. Using the controls on the 400W Series unit front panel, make the selections below and verify the interfaces as appropriate:

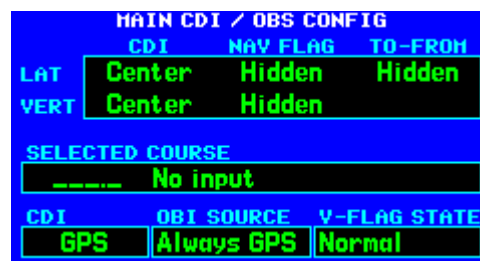

Figure 5-14. MAIN CDI/OBS CONFIG Page

CDI (LAT/VERT)

Selection	Verify That:
Max left	The CDI is “pegged” to the left.
Full left	The CDI is deflected full scale to the left.
Center	The CDI is centered.
Full right	The CDI is deflected full scale to the right.
Max right	The CDI is “pegged” to the right.

NAV FLAG (LAT/VERT)

Selection	Verify That:
Hidden	The LAT/VERT flag is hidden.
In view	The LAT/VERT flag is in view.

TO-FROM

Selection	Verify That:
FROM	The FROM flag is in view.
Hidden	The TO/FROM flag is hidden.
TO	The TO flag is in view.

SELECTED COURSE

Select 150° on the CDI/HSI that is connected to the 400W Series unit’s MAIN OBS inputs. The **SELECTED COURSE** field indicates near to 150° and a **Calibrate to 150°?** field appears. Selecting this field calibrates the 400W Series unit to match the input source. Verify OBS operation by checking that the course displayed on the 400W Series unit is within 2° of the selected course. Do this at 30° intervals around the OBS card.

NOTE



If it is desired to ignore a selected course input (either analog resolver or ARINC 429) for GPS operation in OBS mode, press MENU on the MAIN CDI/OBS CONFIG page and select “Ignore SEL CRS for GPS?”. When OBS mode is selected, the selected course is entered on the controls of the 400W Series unit. If ignoring the selected course input such that the VOR valid flag is dependent only on a valid VOR signal, with lateral deviation calculated by another display device, press MENU on the MAIN CDI/OBS CONFIG page and select “Ignore SEL CRS for VLOC?”.

CDI (GNS 430W Only)

Selection	Description
GPS	The GNS 430W CDI button is in the GPS state, and the GPS ANNUNCIATE output is active. This annunciator output may be required to be active for some installations.
VLOC	The GNS 430W CDI button is in the VLOC state, and the VLOC ANNUNCIATE output is active.

NOTE



If it is desired to disable the GNS 430W CDI key, press MENU on the MAIN CDI/OBS CONFIG page and select “Ignore CDI Key?”. This causes the field above the CDI key to always display GPS, regardless of CDI key presses. This may be necessary for certain EFIS systems where navigation sensor selection must be accomplished on the EFIS or its control panel.

OBI SOURCE (GNS 430W Only)

Selection	Description
Always GPS	The MAIN King Serial OBI outputs are always GPS. This is useful if it is desired to switch a Bendix/King KI 229 or KNI 582 RMI pointer independently from the GNS 430W CDI button.
Track CDI	The MAIN King Serial OBI outputs are GPS or VOR, and switchable by the GNS 430W CDI button. This is useful if it is desired the Bendix/King KI 229 or KNI 582 RMI pointer to display the same navigation source as the GNS 430W CDI outputs.

V-FLAG STATE (Main software version 3.20 or later)

Selection	Description
Declutter	Whenever vertical deviation is invalid, the vertical deviation bar is parked in the maximum UP position and the vertical flag is removed from view, except in the following cases: (i) the CDI is in VLOC mode and an ILS frequency is tuned, or (ii) the CDI is in GPS mode and a GPS approach with vertical guidance is active. In these cases, whenever the vertical deviation is invalid, the vertical deviation bar parks in the centered position and the vertical flag is shown.
Normal	Whenever vertical deviation is invalid the vertical deviation bar parks in the centered position and the vertical flag is shown.

5.3.12 COM SETUP Page (GNC 420W and GNS 430W Only)

Select the COM SETUP Page (see Figure 5-15). These values are set at the factory and seldom require calibration.



Figure 5-15. COM SETUP Page

FREQ

Selects a VHF communication frequency. For purposes of setting the squelch and sidetone levels, only the frequencies 118.000, 127.000, and 136.975 MHz can be used.

SPACING

Selection	Description
25.0 kHz	Selects traditional 25 kilohertz spacing (760 channel).
8.33 kHz	Selects 8.33 kilohertz channel spacing, which is required in some areas of the world.



CAUTION

8.33 kHz channels are not authorized for use in the United States.

SQ 250

Sets the squelch threshold for 25 kHz channel spacing operation. May be set to any value between 0 (zero) and 63. The higher the number, the less signal is required to break squelch.

NOTE



For GNC 420W or GNS 430W units with COM software 2.00 or earlier, the operation of the SQ 250 setting is reversed. The higher the SQ 250 number, the more signal is required to break squelch.

SQ 833

Sets the squelch threshold for 8.33 kHz channel spacing operation. May be set to any value between 0 (zero) and 63. The higher the number, the more signal is required to break squelch.

SIDE

Sets the sidetone audio output level. May be set to any value between 0 (zero) and 63.

NOTE



The sidetone audio output level is independent of the COM volume knob on the 400W Series unit.

Store Calibration?

Select this field and press the ENT key to accept the squelch threshold and sidetone audio settings on this page. If you wish for the squelch and sidetone settings to return to their previous values, *do not* select this field. Simply change to the next configuration page, or turn off the unit if you are done with configuration.

Selection	Verify That:
PTT	The box is filled in while the COM push-to-talk switch is pressed.
XFR	The box is filled in while a remote COM transfer switch is pressed.
RX	The box is filled in while the COM is receiving a signal.
TX	The box is filled in while the COM push-to-talk switch is pressed.

5.3.13 VOR DISCRETE INPUTS Page (GNS 430W Only)

Select the VOR DISCRETE INPUTS Page (see Figure 5-16). This page allows you to verify the operation of an external VLOC transfer switch that may be present in the installation.



Figure 5-16. VOR DISCRETE INPUTS Page

Selection	Verify That:
REMOTE XFR	The box is filled in while a remote VLOC transfer switch is pressed.

5.3.14 VOR/LOC/GS CDI Page (GNS 430W Only)

Select the VOR/LOC/GS CDI Page (see Figure 5-17).

This page allows you to verify and calibrate the CDI outputs, both lateral (LAT) and vertical (VERT) from the VOR/LOC/Glideslope receiver, as well as the OBS resolver input to the VOR receiver. It also allows you to select the format for DME tuning data. Using the controls on the GNS 430W front panel, make the selections below and verify the interfaces as appropriate:

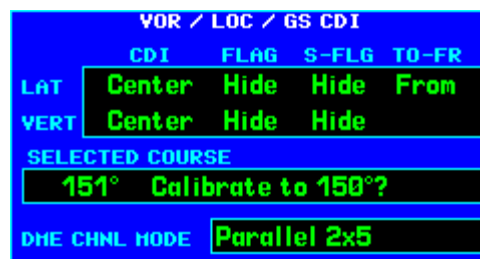

Figure 5-17. VOR/LOC/GS CDI Page

NOTE



The LAT, VERT, and SELECTED COURSE configurations only apply to installations where a CDI/HSI is connected to the VOR/LOC/GLIDESLOPE pins on connector P4006.

CDI (LAT/VERT)

Selection	Verify That:
Max left	The CDI is “pegged” to the left/up.
Full left	The CDI is deflected full scale to the left/up.
Std. left	The CDI is deflected left of center.
Center	The CDI is centered.
Std. right	The CDI is deflected right of center.
Full right	The CDI is deflected full scale to the right/down.
Max right	The CDI is “pegged” to the right/down.

FLAG (LAT/VERT)

Selection	Verify That:
Hide	The LAT/VERT flag is hidden.
View	The LAT/VERT flag is in view.

S-FLG (LAT/VERT)

Selection	Verify That:
Hide	The LAT/VERT superflag is hidden.
View	The LAT/VERT superflag is in view.

TO-FR (LAT)

Selection	Verify That:
FROM	The FROM flag is in view.
Hide	The TO/FROM flag is hidden.
TO	The TO flag is in view.

SELECTED COURSE

Select 150° on the CDI/HSI that is connected to the 400W Series VOR/LOC/GS OBS inputs. The **SELECTED COURSE** field should indicate near to 150° and a **Calibrate to 150°?** field appears. Selecting this field calibrates the 400W Series to match the input source. Verify OBS operation by checking that the course displayed on the 400W Series is within 2° of the selected course. Do this at 30° intervals around the OBS card.

DME CHNL MODE

This configuration allows you to set the format for DME tuning data output.

Selection	Description
King serial	King Serial DME tuning data
Parallel 2x5	2 of 5 parallel DME tuning.
Parallel BCD	Shifted BCD (Binary Coded Decimal) parallel DME tuning
Parallel slip	Slip-code parallel DME tuning
Narco 890/891	2 of 5 parallel DME tuning, compatible with the following DME units: <i>Narco DME 890</i> <i>Narco DME 891</i> <i>ARC (Cessna) RTA-476A</i>

5.3.15 VOR/LOC/GS ARINC 429 CONFIG Page (GNS 430W Only)

Select the VOR/LOC/GS ARINC 429 CONFIG Page (see Figure 5-18). This page configures the VOR/ILS ARINC 429 output and input ports.

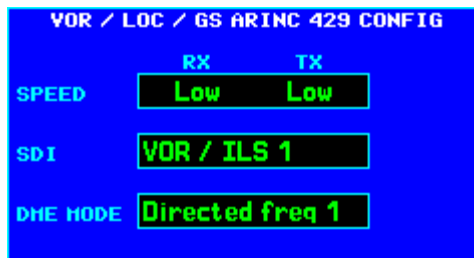

Figure 5-18. VOR/LOC/GS ARINC 429 CONFIG Page

SPEED

Selection	Description
Low	Standard low-speed ARINC 429 (nominally 12.5 kilobits per second)
High	High-speed ARINC 429 (nominally 100 kilobits per second)

SDI

Selection	Description
Common	RX: Accepts all 429 inputs TX: Generates all 429 outputs with SDI = 0.
VOR/ILS 1	Number 1 (Pilot) VOR/ILS Receiver RX: Accepts 429 inputs with SDI = 0 or 1. TX: Generates all 429 outputs with SDI = 1.
VOR/ILS 2	Number 2 (Copilot) VOR/ILS Receiver RX: Accepts 429 inputs with SDI = 0 or 2. TX: Generates all 429 outputs with SDI = 2.

DME MODE

Selection	Description
Directed freq 1	If the GNS 430W is connected to a multi-channel ARINC 429 DME, channel 1 of that DME is tuned. "Directed freq 1" should be selected if a single-channel ARINC 429 DME is tuned.
Directed freq 2	If the GNS 430W is connected to a multi-channel ARINC 429 DME, channel 2 of that DME is tuned.

5.3.16 GPS Vertical Offset

The GPS Vertical Offset setup function is used to enter the height above ground of the GPS antenna. Prior to proceeding, measure the GPS antenna vertical offset (to the nearest foot) as shown in Figure 5-19.

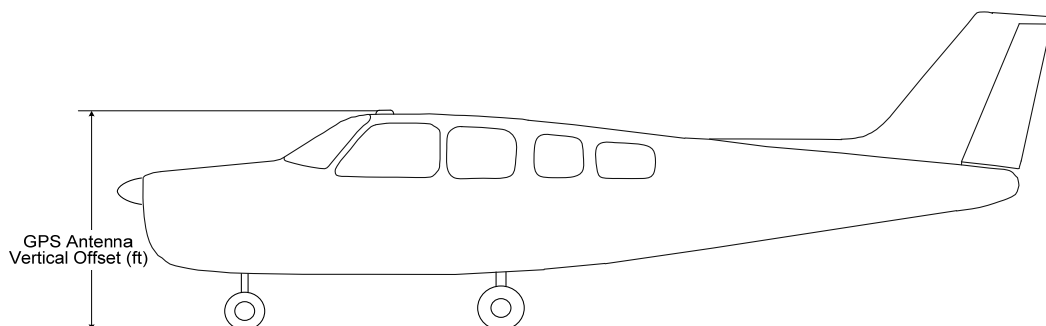

Figure 5-19. Measurement of GPS Vertical Offset

Use the large and small knobs to enter the offset value and press ENT to save.



Figure 5-20. GPS Vertical Offset Page

5.3.17 STORMSCOPE CONFIG Page

NOTE



The Stormscope pages are only available if one of the RS-232 inputs is configured for the WX-500.

Select the STORMSCOPE CONFIG Page (see Figure 5-21). This page shows the L3 Communications WX-500 Stormscope configuration as reported by the WX-500 through RS-232 data.

Verify that the **STATUS** field indicates “Ok”, and that the other displayed parameters are correct. Verify that all the boxes in the lower portion of the page are green.

When a 400W Series unit is used with a WX-500 Stormscope, the “Synchro” or “Serial” heading formats may be used. If another heading format is used, lightning strike information is visible on the Weather Page, but not the Map Page or Arc Page.

5.3.18 STORMSCOPE TEST Page

Select the STORMSCOPE TEST Page (see Figure 5-22). This page shows current strike activity, WX-500 status, and the heading supplied by the WX-500. The WX-500 mode may be changed to ‘Demo’, ‘Noise monitor’, ‘Self test’, ‘Strike test’, or ‘Weather’.

Verify that the WX-500 mode can be changed. Refer to the WX-500 manual for specific installation test procedures for the WX-500, using this page to view strike data, change the WX-500 mode, view WX-500 status, trigger count, and heading.

5.3.19 STORMSCOPE DOWNLOAD DATA Page

Select the STORMSCOPE TEST Page (see Figure 5-23). This page shows raw data downloadable from the WX-500. Optional sets of data include WX-500 software version, environmental conditions, configuration, and fault data.

Verify that the configuration data is correct as intended. To request which packet of data to display, highlight the data group title and use the small right knob to select the desired group.

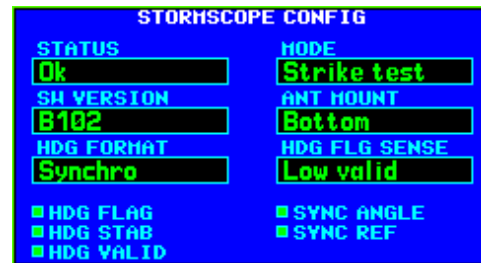

Figure 5-21. STORMSCOPE CONFIG Page



Figure 5-22. STORMSCOPE TEST Page



Figure 5-23. STORMSCOPE DOWNLOAD DATA Page

5.3.20 TRAFFIC Page

NOTE



The following pages are only available if one of the RS-232 inputs is configured for the Ryan TCAD or one of the ARINC 429 inputs is configured for Traffic Advisory.

Select the TRAFFIC Page (see Figure 5-24). This page shows the L3 Communications SkyWatch or Ryan TCAD modes of operation and current traffic situation.

For L3 Communications SkyWatch, this page shows:

1. The altitude mode—below (BLW), normal (NORM), above (ABV), or unrestricted (UNR)
2. The operating mode—standby (STBY) or operating (OPER)
3. Current altitude (ALT)
4. Altitude limits being imposed (LIM A and LIM B)
5. Heading, and barometric (BARO) and radio (RAD) altitude status.



Figure 5-24. TRAFFIC Page (SkyWatch)

For L3 Communications SkyWatch (see Figure 5-24), verify that the 400W Series unit can change the SkyWatch operating mode (STBY or OPER). In standby mode, verify that the SkyWatch may be placed in self-test mode by highlighting “Test Mode?” and pressing ENTER on the 400W Series unit. Refer to the L3 Communications SkyWatch installation manual for system checkout.

For Ryan TCAD (see Figure 5-25), this page shows the current shield mode and altitude. Verify that the TCAD shield mode may be changed—Ground (GND), Terminal (TML), Standard (STD), En Route (ENR), or Unrestricted (UNR), and that the TCAD is reporting the correct altitude. Refer to the Ryan TCAD installation manual for system checkout.



Figure 5-25. TRAFFIC Page (TCAD)

NOTE



For main software version 3.20 or later, an alternate traffic color is available by pressing the MENU key while on the TRAFFIC page and selecting “Use Alternate Trfc Color?” Selection of this option causes non-TA traffic to be displayed in cyan instead of white, which is the default color. The alternate traffic color is not covered under the Garmin AML STC and shall not be used unless an alternate means of airworthiness approval is obtained.

5.3.21 RYAN TCAD CONFIG Page

Select the RYAN TCAD CONFIG Page (see Figure 5-26). This page shows the TCAD's current shield settings for the selected mode, approach mode status, volume, mute status, mute duration, voice alert selection, and system status.

Verify that the TCAD system status is GREEN. Also, verify that shield settings and volume, mute duration, and voice alert selection can be modified. Verify that changes in mute (if a mute switch is installed) are shown. Refer to the Ryan TCAD installation manual for system checkout.

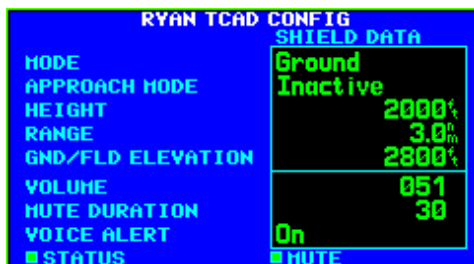

Figure 5-26. RYAN TCAD CONFIG Page

5.3.22 GAD 42 CONFIG Page

The following page is only available if a ARINC 429 input is configured for the GAD 42.

Select the GAD 42 CONFIG Page (see Figure 5-27). This page allows remote configuration of a GAD 42 Interface Adapter Unit. For details of this function, please refer to Section 5 of the GAD 42 Installation Manual (P/N 190-00159-00).

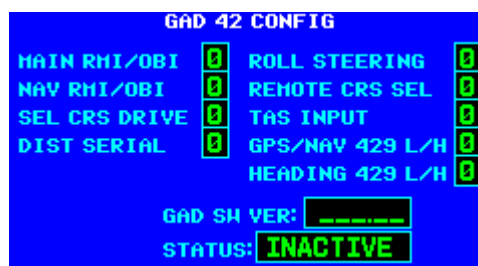

Figure 5-27. GAD 42 CONFIG Page

5.3.23 GDL CONFIG Page

This page allows the user to set the attenuation and model of the GDL 69. It is only available if one of the RS-232 ports is configured for the GDL 69/69A.

The GDL 69A XM must be activated before use. If the XM activation has not already been done, see the GDL 69/69A Installation Manual (190-00355-02) and the GDL 69/69A XM Activation Instructions (190-00355-04).

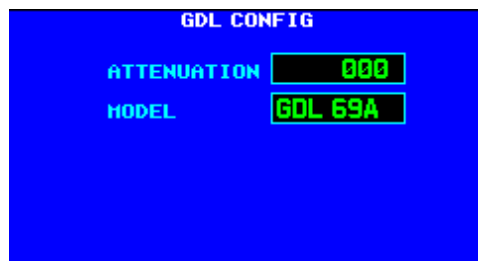

Figure 5-28. GDL CONFIG Page

Selection	Description
Attenuation	Sets the attenuation value for the GDL 69/69A. Refer to the GDL 69/69A Installation manual (190-00355-02) to determine the correct attenuation value.
Model	Sets the model to either GDL 69 (weather only) or GDL 69A (weather and audio).

5.3.24 DATA LINK DIAGNOSTICS Page

The 8-character test word returned from the GDL 69 is displayed on the DATA LINK DIAGNOSTICS page for each of the following parameters:



Figure 5-29. Data Link Diagnostics

Display	Description
QOS	Quality of Service Test
TERR	Terrestrial Error Status
SAT1	Satellite 1 Error Status
SAT2	Satellite 2 Error Status
TUNER	Tuner Status

5.4 Ground Checks (Configuration Mode)

5.4.1 Main Indicator (Analog Only)

NOTE



If the GNS 400W Series unit is interfaced to an electronic HSI and the main indicator analog output is not used, this check is not required.

If the GNS 400W Series unit is interfaced to an analog indicator on the main CDI/OBS, perform the following steps:

1. Go to the MAIN CDI / OBS CONFIG page.
2. Verify correct operation of the lateral deviation, flag and TO/FROM flag using the corresponding selections.
3. Verify correct operation of the vertical deviation and flag using the corresponding selections.
4. Verify correct operation of the OBS knob using the SELECTED COURSE display. At 30° increments around the OBS card, ensure that the indicated value is within 2° of the value set on the indicator.

5.4.2 VOR/ILS Indicator (GNS 430W Only)

If the GNS 430W unit is interfaced to an analog indicator on the VOR/ILS Indicator output, perform the following steps:

1. Go to the VOR / LOC / GS CDI configuration page.
2. Verify correct operation of the lateral deviation, flag and TO/FROM flag using the corresponding selections.
3. Verify correct operation of the vertical deviation and flag using the corresponding selections.

5.4.3 Discrete Inputs and Annunciator Outputs Checkout

If the GNS 400W Series unit is connected to external annunciators/systems or external switches, perform the following steps:

1. Go to the MAIN DISCRETE INPUTS page.
2. For each external switch that is connected, exercise the switch and use the EXTERNAL SWITCH STATE section to verify that the input is functioning correctly.
3. Go to the MAIN DISCRETE OUTPUTS page.
4. For each annunciator output that is connected to an external system or annunciator, toggle the output ON (corresponding box is filled/green) and OFF (corresponding box is not filled/blue) using the DISCRETE TOGGLE field. Verify that the appropriate external annunciator illuminates when the output is set to ON and extinguishes when the output is set to OFF. If the output is not connected to an annunciator but provides an input to another system, verify that the other system receives the signal.

5.4.4 ADC, Altitude Encoder, Fuel Sensor and Fuel/Air Data Computer

NOTE



This check does not apply to parallel connections to an altitude encoder. If the gray code interface to an altitude encoder is used, the check in Section 5.4.5 must be completed.

The GNS 400W Series unit can receive altitude or fuel/air data from an external source. This check verifies that the GNS 400W Series unit is receiving data from these units. Ensure that the GNS 400W Series unit is turned on and in configuration mode. If the following steps do not perform correctly, check the electrical connections and configuration setup.

1. Go to the Main Inputs 1 page.
2. If there are multiple altitude sources providing data to the GNS 400W Series unit, remove power from all but one altitude source.
3. Verify that pressure altitude (P ALT) data is being displayed and agrees with the active altitude source.

NOTE



After applying power to an altitude source it may take several minutes to warm up. During the warm-up period the altitude display on the GNS 400W Series unit will be dashed out.

4. If there are multiple altitude sources, remove power from the currently active source and apply power to another source that has not been checked.
5. Repeat steps 3 and 4 until all available altitude sources have been checked.

5.4.5 Altitude Encoder (Gray Code Connection)

The GNS 400W Series unit can receive altitude from an external gray code encoder or encoding altimeter. This check verifies all of the connections in the parallel gray code interface. If the following steps do not perform correctly, check the electrical connections and configuration setup.

1. Go to the Main Discrete Inputs page.
2. Using a pitot-static test set, set the altitude to the values specified below:

Pitot-Static Test Set Altitude	Tolerance (ft)
400	± 20
800	± 20
2000	± 30
10,000	± 80
16,000	± 110
30,800	± 180

3. Verify that decoded altitude data is being displayed is equal to the test set altitude, within the tolerance specified.

5.4.6 AHRS/IRU Interface Check

The GNS 400W Series unit can receive heading data from an external source. This check verifies that the GNS 400W Series unit is receiving data from these units. Ensure that the GNS 400W Series unit is turned on and in configuration mode. If the following steps do not perform correctly, check the electrical connections and configuration setup.

1. Go to the Main Inputs 1 page.

NOTE



If a Sandel EHSI or an ARINC 429 EFIS is also installed, ensure that it is turned off so that it does not supply heading to the GNS 400W Series unit.

2. Verify that the HDG field displays valid heading data.
3. Remove power from the heading source and verify that the heading in the HDG field is dashed out.

5.4.7 GAD 42 Interface Check

This check verifies that the GNS 400W Series unit is interfaced with the GAD 42. For the 400W Series units, the GAD 42 CONFIG page is implemented in main software version 2.20 or higher.

1. Go to the GAD 42 CONFIG page.
2. Verify that STATUS is ACTIVE.
3. Change any of the options to a different number.
4. Verify that after pressing ENT the STATUS field will change to SENDING then change back to ACTIVE. If the entry reverts to the previous number when ACTIVE is displayed, then refer to the GAD 42 Installation Manual (P/N 190-00159-00).

5.4.8 Lighting Bus Interface Check

The display and key backlighting on the 400W Series unit can track an external lighting/dimmer bus input and use it to vary the display and key backlight levels accordingly. This check verifies that the interface is connected correctly.

CAUTION



When 14 VDC or 28 VDC lighting buses are connected to the 400W Series unit, connection of the aircraft lighting bus to the incorrect input pins can cause damage to the 400W Series unit. Always start this test with the dimming bus at the lowest setting, and slowly increase the brightness. If it is noticed that the LIGHTING level displayed on the 400W Series unit does not increase as the lighting is increased in brightness, verify that the wiring is correct before proceeding.

1. Ensure the lighting bus is set to its minimum setting.
2. Go to the Main Lighting page.
3. Slowly vary the lighting bus that is connected to the 400W Series unit. Verify that the LIGHTING value displayed on the configuration screen tracks the lighting bus setting.

5.5 Ground Checks (Normal Mode)

Turn the 400W Series unit off and bring the unit back up in normal mode for the following checks.

5.5.1 Display of Self-Test Data

Following normal power-up, the Data Base Pages are displayed followed by the Instrument Panel Self-Test Page. Pressing the ENT key once then displays the Instrument Panel Self-Test page (see Figure 5-8). During this time, the electrical outputs are activated and set to the values listed below. Press the ENT key to acknowledge the self test page. This is not a required check, although this page can be useful in troubleshooting installation problems.

NOTE



Electronic displays which monitor the 400W Series unit's ARINC 429 output may vary in how and where annunciations are displayed.

Parameter	Self-Test Value
Course Deviation	Half-scale left deviation, TO indication, flag pulled
Glideslope/Vert. Deviation	Half-scale up deviation, flag pulled
Annunciators	All On
Bearing to Waypoint (RMI)	135°
Selected Course (OBS)	400W Series unit displays the OBS value (149.5° if interfaced to an HSI with driven course pointer).
Desired Track	149.5° (Displayed as 150°)
<i>Items below are not displayed on the INSTRUMENT PANEL SELF-TEST page</i>	
Distance to Go	10.0 nautical miles
Time to Go	4 minutes
Active Waypoint	"GARMN"
Groundspeed	150 knots
Present Position	N 39°04.05', W 94°53.86'
Waypoint Alert	Active
Phase of Flight	En Route
Message Alert	Active
Leg/OBS Mode	Leg Mode
GPS Integrity	Invalid
Roll Steering (if applicable)	Flight Director commands 0° bank (level flight) for 5 seconds; commands increasing right bank at 1°/second for 5 seconds; commands 5° right bank for 5 seconds; commands decreasing right bank at 1°/second for 5 seconds, until command is 0° bank again. This cycle repeats continuously.

5.5.2 Signal Acquisition Check

NOTE



All other avionics should be turned off at the start of this test. Turn on the GNS 400W Series unit.

Upon acknowledgement of the Instrument Panel Self-Test Page, the Satellite Status Page is displayed. If the unit is unable to acquire satellites, relocate the aircraft away from obstructions which might be shading GPS reception. If the situation does not improve, check the GPS antenna installation.

NOTE



After installation, the initial acquisition of position can take up to 20 minutes. Subsequent acquisitions will not take that long.

Once GPS position information is available, perform the following steps:

1. On the Position Page, verify that the lat/lon agree with a known reference position.
2. While monitoring the Satellite Status Page, turn on other avionics one at a time and check the GPS signal reception to make sure it is not affected (no significant signal degradation).
3. Before proceeding with the VHF COM interference check, ensure that any connected equipment is transmitting and/or receiving data from the 400W Series unit and is functioning properly.

5.5.3 VHF COM Interference Check

NOTE



The interference check must be completed on all IFR installations.

NOTE



It is known that certain non-aviation radios, including marine transceivers, can interfere with civil aviation navigation and surveillance equipment including the Garmin GNS 400W Series. When installing GNS 400W Series equipment in accordance with the appropriate STC, it is the responsibility of the installer to ensure that the GNS 400W Series unit modification is compatible with all previous aircraft modifications. Garmin recommends that whenever a GNS 400W Series unit is installed in an aircraft that has been modified with non-aviation radios, particular care should be exercised to verify that these do not interfere with proper function of the GNS 400W Series unit. Special care should also be taken to ensure that there is no interference with the GNS 400W Series unit if non-aviation radios are installed in an aircraft after a GNS 400W Series unit has been installed. If interference is found, it can be addressed by relocating antennas, rerouting cables, using filters to attenuate unintentional harmonic frequency transmissions, or using various other techniques for elimination of the interference. It may be necessary to remove or replace the interfering radio with a model that does not interfere with the proper functioning of the GNS 400W Series unit.

If you are testing a transmitter from a non-aviation device, each frequency must be verified by transmitting for at least 30 seconds on each channel.

Once the Signal Acquisition Test has been completed successfully, perform the following steps:

1. View the Satellite Status Page and verify that at least 7 satellites have been acquired on the 400W Series unit.
2. Verify that the GPS “INTEG” flag is out of view.
3. Select 121.150 MHz on the COM transceiver to be tested.
4. Transmit for a period of 35 seconds.
5. Verify that the GPS “INTEG” flag does not come into view.
6. Repeat steps 4 and 5 for the following frequencies:

25 kHz COM Channel Spacing

- 121.150 MHz
- 121.175 MHz
- 121.200 MHz
- 121.225 MHz
- 121.250 MHz
- 131.200 MHz
- 131.225 MHz
- 131.250 MHz
- 131.275 MHz
- 131.300 MHz
- 131.325 MHz
- 131.350 MHz

NOTE



For VHF radios with 8.33 kHz channel spacing, include the following frequencies in addition to those listed above.

8.33 kHz COM Channel Spacing

- 121.185 MHz
- 121.190 MHz
- 130.285 MHz
- 131.290 MHz

7. Repeat steps 3 through 6 for all remaining COM transceivers installed in the aircraft.
8. If aircraft is TCAS-equipped, turn on the TCAS system and verify that GPS position remains valid (if position is lost, the status on the Satellite Status Page will change to “ACQUIRING”).
9. If aircraft is SATCOM-equipped, use the SATCOM system and verify that GPS position remains valid (if position is lost, the status on the Satellite Page will change to “ACQUIRING”).
10. If the GPS “INTEG” flag comes into view, see Section 2.4.6 for options to improve performance.

5.5.4 VHF NAV Checkout (GNS 430W)

Press the CDI key to select VLOC mode (indicated by a white VLOC in the lower left corner of the display). Check the VOR reception with ground equipment, operating VOT or VOR, and verify audio and Morse code ID functions (if possible). Tune a Localizer frequency and verify the CDI needle and NAV flag, and VDI needle and GS flag operation.

5.5.5 VHF COM Checkout (GNC 420W/GNS 430W)

5.5.5.1 Antenna Check

If desired, the antenna VSWR can be checked using an inline wattmeter in the antenna coax using frequencies near both ends of the band. The VSWR should be < 2:1, and is not to exceed 3:1. A VSWR of 2:1 will cause a drop in output power of approximately 12%, and 3:1 causes approximately a 26% drop.

5.5.5.2 Receiver / Transmitter Operation

Tune the unit to a local VHF frequency and verify the receiver output produces a clear and understandable audio output. Verify the transmitter functions properly by contacting another station and getting a report of reliable communications.

5.5.6 Interface Checkout

This section describes checks that must be carried out to verify that systems interfacing to the GNS 400W Series unit are communicating properly. Only those interfaces that are connected to the GNS 400W Series unit must be verified.

5.5.6.1 Honeywell (Bendix/King) EFS40/50 Interface Check

If a Honeywell EFS40/50 has been connected to GNS 400W Series unit the interface should be verified as described in this section.

1. Cycle power to the first GNS 400W Series unit and acknowledge the prompts until it gets to the self test page (see Section 5.5.1).
2. Ensure that GPS1 data is displayed by pressing the “1-2” key on the EFS40/50 control panel.
3. While the GNS 400W Series unit is displaying the self test page, verify that the EFS40/50 is displaying data from the GPS source. Note that vertical deviation will not be displayed.
 - Course Deviation: Half-scale left deviation, TO indication, flag pulled
 - Active Waypoint: GARMN
 - Vertical Deviation: Half-scale up deviation (Only if installation is set up to display GPS vertical deviation)
4. On the GNS 400W Series unit verify that an OBS value is displayed (and not dashed out).
5. Using a VOR test set verify that the CDI deviation on the EFS40/50 is displayed correctly.
6. Cycle power to the second GNS 400W Series unit and acknowledge the prompts until it gets to the self test page (see Section 5.5.1).
7. Switch to GPS2 data by pressing the “1-2” key on the EFS40/50 control panel and repeat steps 3 through 5 with the second GNS 400W Series unit.

5.5.6.2 Sandel SN3308 Interface Check

If a Sandel SN3308 EHSI has been connected to the GNS 400W Series unit, the interface should be verified as described in one of the following sections, as appropriate for the installation.

5.5.6.2.1 One 400W Series Unit / One SN3308

1. Cycle power to the GNS 400W Series unit and acknowledge the prompts until it gets to the self test page (see Section 5.5.1).
2. Ensure that the SN3308 is receiving valid heading.

NOTE



The Vertical Deviation Indication will not be displayed unless the SN3308 is receiving valid heading.

3. While the GNS 400W Series unit is displaying the self test page, verify that the SN3308 is displaying the following data from the GPS source.
 - Course Deviation: Half-scale left deviation, TO indication, flag pulled
 - Vertical Deviation: Half-scale up deviation, flag pulled
 - Active Waypoint: GARMN
4. On the GNS 400W Series unit verify that an OBS value is displayed (and not dashed out).
5. Acknowledge the self test on the GNS 400W series unit by pressing the ENT key.
6. Select VLOC on the GNS 400W Series unit and verify that the SN3308 displays NAV 1 or NAV 2 (depending on what navigation source the GNS 400W is).
7. Using a VOR test set verify that the CDI deviation on the SN3308 is displayed correctly.

5.5.6.2.2 Two 400W Series Units/One SN3308

The checkout for two 400W Series units also applies to one 400W Series unit and one 500W Series unit.

1. Remove power from the second (no. 2) 400W Series unit.
2. Cycle power to the first GNS 400W Series unit and acknowledge the prompts until it gets to the self test page (see Section 5.5.1).
3. Select GPS1 as the navigation source by pressing the NAV key on the SN3308.
4. Ensure that the SN3308 is receiving valid heading.

NOTE



The Vertical Deviation Indication will not be displayed unless the SN3308 is receiving valid heading.

5. While the first GNS 400W Series unit is displaying the self test page, verify that the SN3308 is displaying the following data from GPS1.
 - Course Deviation: Half-scale left deviation, TO indication, flag pulled
 - Vertical Deviation: Half-scale up deviation, flag pulled
 - Active Waypoint: GARMN
6. On the first GNS 400W Series unit verify that an OBS value is displayed (and not dashed out).
7. Acknowledge the self test on the first GNS 400W Series unit by pressing the ENT key.
8. Select VLOC on the first GNS 400W Series unit and verify that the SN3308 displays NAV 1 or NAV 2 (depending on what navigation source the GNS 430W is).
9. Using a VOR test set verify that the CDI deviation on the SN3308 is displayed correctly.
10. Remove power to the first 400W Series unit and apply power to the second 400W Series unit and acknowledge the prompts until it gets to the self test page (see Section 5.5.1).
11. Select GPS2 by pressing the NAV key on the SN3308.
12. Repeat steps 4-9 with the second GNS 400W Series unit.

5.5.6.3 Sandel SN3500 Interface Check

IF a Sandel SN3500 EHSI has been connected to a 400W Series unit, the interface should be verified as follows:

1. Cycle power to the GNS 400W Series unit and acknowledge the prompts until it gets to the self test page (see Section 5.5.1).
2. Ensure that the SN3500 is receiving valid heading.

NOTE



The Vertical Deviation Indication will not be displayed unless the SN3500 is receiving valid heading.

3. While the GNS 400W Series unit is displaying the self test page, verify that the SN3500 is displaying data from the GPS source.
 - Course Deviation: Half-scale left deviation, TO indication, flag pulled
 - Vertical Deviation: Half-scale up deviation, flag pulled
 - Active Waypoint: GARMN

NOTE



If the Vertical Deviation Indication is not displayed ensure that the Main ARINC 429 Config (See Section 5.3.1) is set to Enable Labels for VNAV.

4. On the GNS 400W Series unit verify that an OBS value is displayed (and not dashed out).
5. Acknowledge the self test on the GNS 400W Series unit by pressing the ENT key.
6. Select VLOC on the GNS 400W Series unit and verify that the SN3308 displays NAV 1 or NAV 2 (depending on what navigation source the GNS 430W is).
7. Ensure that the NAV1 (or NAV2) indication does not have a red line through it.

5.5.6.4 EHSI Deviation Scaling (If HSI/CDI Is Driven by the 400W Series Unit Via Serial Data)

If the GNS 400W Series unit has a serial connection to an EFIS display not covered by the AML STC, proper scaling of the EFIS CDI and VDI must be verified.

1. Cycle power to the GNS 400W Series unit and acknowledge the prompts until it gets to the self test page (see Section 5.5.1).
2. With the self test page displayed on the GNS 400W Series unit, look on the EHSI/EFIS and verify that the lateral deviation is not flagged and half-scale left.
3. With the self test page displayed on the GNS 400W Series unit, look on the EHSI/EFIS and verify that the vertical deviation is not flagged and half-scale up.

NOTE



If the deviations are not as described, the EHSI/EFIS does not scale the GNS 400W Series unit deviations properly and cannot be certified for GPS-based guidance. Contact Garmin for further assistance.

5.5.6.5 ARINC 429 Traffic System Interface Check

If an L3 Communications SKY497/SKY899 SkyWatch® sensor or a Honeywell (Bendix/King) KTA 810 TAS/KMH 820 IHAS has been connected to the GNS 400W Series unit, the traffic interface should be verified as described in this section.

1. Go to the Traffic page on the GNS 400W Series unit (in the NAV page group).
2. Verify that NO DATA is not displayed in yellow on the center of the traffic page.
3. Verify that the traffic system mode can be changed from STBY to OPER.
4. Switch the traffic system mode to STBY, and then run the traffic self test from the Menu.
5. Verify that the traffic system executes a self test and a self-test pattern is displayed on the GNS 400W Series unit.

5.5.6.6 Ryan TCAD Traffic System Interface Check

If a Ryan TCAD has been connected to the GNS 400W Series unit, the traffic interface should be verified as described in this section.

1. Go to the Traffic page on the GNS 400W Series unit (in the NAV page group).
2. Verify that NO DATA is not displayed in yellow on the center of the traffic page.
3. Using the SETUP selection under the Traffic Menu, verify that the shield mode can be changed.

5.5.6.7 Stormscope Interface Check

If an L3 Communications WX-500 Stormscope has been connected to the GNS 400W Series unit, the Stormscope interface should be verified as described in this section.

1. Go to the Lightning page on the GNS 400W Series unit (in the NAV page group).
2. Verify that LIGHTNING FAILED is not displayed in yellow on the center of the Lightning page.
3. Using the Self Test selection under the Lightning Menu, initiate a Stormscope self-test.

5.5.6.8 GMX 200/MX20 Interface Check

If a Garmin GMX 200 or MX20 has been connected to the GNS 400W Series unit, the interface should be verified as described in this section.

1. Ensure that the GNS 400W Series unit has a 3-D fix.
2. Create and activate a flight plan on the GNS 400W Series unit.
3. Verify that the RTE and POS data flags are not displayed on the GMX 200/MX20.
4. Verify that the flight plan is displayed on the GMX 200/MX20 using the flight plan (FPL) function.

5.5.6.9 GDL 69/69A Interface Check

If a Garmin GDL 69 has been connected to the GNS 400W Series unit, the interface should be verified as described Section 5.5.6.9.1. If a Garmin GDL 69A has been connected to the GNS 400W Series unit, the interface should be verified as described Sections 5.5.6.9.1 and 5.5.6.9.2. Each of these procedures involves verifying that the satellite signal is acquired and tracked. Locate the aircraft where there is a clear view of the southeastern or southwestern sky. XM Satellite Radio satellites are located above the equator over the eastern and western coasts of the continental United States.

NOTE



The following sections only verify the correct interface of GDL 69/69A to the GNS 400W Series unit. It does not activate the GDL 69 XM data link radio. Complete instructions for activating the XM data link radio can be found in document 190-00355-04.

5.5.6.9.1 XM Satellite Radio Weather Checkout Procedure

1. With the 400W Series unit running in the normal mode, go to the XM Information page (in the AUX page group).
2. Verify that the DATA ID field has a valid ID and does not contain “---”. For a GDL 69A, the AUDIO ID field should also display a valid ID.
3. Go to the XM WX Timestamp page and verify that timestamp data is displayed. This may take several minutes. (Timestamp data will not be available if the XM subscription has not been activated.)

During XM activation, “Detecting Activation” will be displayed in the SERVICE CLASS field on the XM Information page, and “Aviator” will be displayed once the XM signal is detected.

5.5.6.9.2 XM Satellite Radio Audio Checkout Procedure

1. Go to the XM Audio page (in the AUX page group).

NOTE



If the XM Satellite Radio audio subscription has not been activated, audio is available only on Channel 1. If the audio subscription has been activated, audio should be available on multiple channels.

2. Ensure that the GDL 69A audio is not muted.
3. Verify that audio can be heard over the headsets. Adjustment of the volume may be required.

5.5.6.10 Crossfill Check (If Dual Units Installed With RS-232 Crossfill Connected)

The crossfill check applies to two 400W Series units as well as to one 400W Series unit and one 500W Series unit.

Turn on both 400W Series units in the aircraft. For each 400W Series unit:

1. Select the first AUX page (titled “FLIGHT PLANNING”).
2. Select “CROSSFILL”.
3. Verify that the displayed status is “Ready”. If “Not Available” is displayed, there may be an RS-232 wiring problem between the two 400W Series units.

5.5.6.11 External RMI/OBI Interface Check

The GNS 400W Series unit RMI/OBI output can be used to drive an RMI (or OBI) navigation indicator. This check verifies that the RMI/OBI is receiving data from the GNS 400W Series unit. If the following steps do not perform correctly, check the electrical connections and configuration setup.

NOTE



The aircraft heading system must be operating properly in order for the RMI needle to point correctly.

5.5.6.11.1 Main OBI Output

If the Main OBI output from the GNS 400W Series unit is connected to an RMI navigation indicator verify the interface as follows:

1. Apply power to the equipment and wait for the GNS 400W Series unit to acquire a position.
2. In the GNS 400W Series unit, set a course to a destination waypoint and ensure GPS is selected for display on the CDI.
3. If installed, set the RMI select switch to the GPS position.
4. Verify that the RMI needle swings and points towards the GPS waypoint selected.
5. If the Main OBI Output is configured to “Track CDI,” ensure that a valid VOR station is not tuned. Select VLOC on the CDI and verify that the RMI needle is parked at the invalid position.
6. If the Main OBI Output is configured to output “Always GPS,” select VLOC on the CDI and verify that the RMI needle still points towards the GPS waypoint selected.

5.5.6.11.2 VOR OBI Output (GNS 430W Only)

If the VOR OBI output from the GNS 430W is connected to an RMI navigation indicator verify the interface as follows:

1. Apply power to the equipment.
2. If installed, set the RMI select switch to the VLOC position.
3. Tune a local VOR station, or use a simulated signal from an approved VOR Test System.
4. Verify that the RMI needle swings and points towards the VOR station.

5.5.6.12 DME Tuning Check (GNS 430W Only)

If the GNS 430W is set up to remotely channel a DME, verify the interface as follows:

1. Select a VOR/ILS channel that corresponds to (1) a DME station within a 40 nautical mile range, or (2) the frequency of a DME ground tester.
2. Verify that the DME locks on to the signal and a valid distance, ground speed and time are displayed.
3. Tune an invalid VOR station. Verify that the DME changes to an invalid station.

5.5.6.13 G600 Interface Check

The GNS 400W Series unit can receive data from the G600 system. Verify the interface in accordance with Section 5.8 of the G600 AML STC Installation Manual (P/N 190-00601-06).

5.5.7 Magnetic Compass Check

Compass swing should be carried out at completion of installation in accordance with AC 43.13-1B, chapter 12, section 3, paragraph 12-37.

5.6 Flight Checks

All system functions that cannot be adequately tested on the ground will require a flight test. Even if all functions can be verified on the ground, a flight test is recommended as final installation verification. Verify system operation as described in the following sections.

NOTE



The analog deviation (LEFT/RIGHT and UP/DOWN), TO/FROM, and FLAG (lateral and vertical) outputs to a CDI or HSI should be verified in flight with potential sources of electrical noise such as autopilot, flaps, gear, heater blowers, etc. operating. Lateral deviation and flags may be checked with either GPS or VOR/ILS, and vertical deviation and flags must be checked with Glideslope. Verify that the flags are hidden at the correct times, and that the flag is in view at the correct times.

5.6.1 GPS Flight Check

1. Verify that GPS position is not lost during normal aircraft maneuvering (e.g. bank angles of up to 30 degrees and pitch angles associated with take-off, departures, approaches, landing and missed approaches as applicable). If GPS position is lost, a “LOSS OF GPS NAVIGATION” message will be displayed.
2. Enter and activate a flight plan on the 400W Series unit. Fly the flight plan and verify that the display of flight plan data is consistent with the CDI indication (deviation, TO/FROM...) in the pilot’s primary field of view.

5.6.2 VHF COM Flight Check (GNC 420W and GNS 430W)

After the installation is complete, a flight test is recommended to ensure satisfactory performance. To check the communications transceiver, maintain an appropriate altitude and contact a ground station facility at a range of at least 50 nautical miles. Contact a ground station in close proximity. Press the COM volume knob to select manual squelch and listen for any unusual electrical noise, which would increase the squelch threshold. If possible, verify the communications capability on both the high low and mid bands of the VHF COM band. It may be required by the governing regulatory agency to verify operation of the COM transmitter and receiver at the extents of a ground facility’s service volume (e.g., FAA AC 23-8A).

5.6.3 VOR Flight Check (GNS 430W)

1. Tune a local VOR station within 50 miles.
2. Verify the audio ident and voice quality and verify that no objectionable electrical interference such as magneto noise is present.
3. Verify the Morse code decoder IDs the station (95% probability).
4. Fly to and from the station.
5. Verify NAV flag, TO/FROM flag, and CDI are operational.
6. Record accuracy in System Log (see manual).

It may be required by the governing regulatory agency to verify operation of the VOR receiver at the extents of a ground facility’s service volume (e.g., FAA AC 23-8A).

5.6.4 ILS Flight Check (GNS 430W)

1. Tune an ILS at the local airport.
2. Verify the audio ident and audio quality and verify that no objectionable electrical interference such as magneto noise is present.
3. Verify the Morse code decoder IDs the station (95% probability).
4. Fly the approach.
5. Verify NAV flag, GS flag, and CDI and VDI are operational.

5.6.5 Autopilot Flight Check

1. Enter and activate a flight plan on the 400W Series unit. For the GNS 430W, ensure that GPS is selected on the CDI. Engage the autopilot in the GPSS mode. Verify that the autopilot flies the course.
2. Disengage the autopilot and fly off course. Re-engage the autopilot (in GPSS mode) and verify that it correctly intercepts the course and continues to fly it.
3. Turn off the autopilot GPSS but leave the autopilot engaged in NAV mode. Verify that it maintains the current course.
4. (GNS 430W Only): Reselect the GPSS mode on the autopilot. Press the CDI key to select VLOC on the 430W. Verify that the GPSS mode disengages.

5.7 Database Check

Check the aviation database to ensure it is current. The database information is displayed during the unit display start-up sequence. To check the database:

2. Turn off the 400W Series units and then turn it on. The 400W Series unit will go through its normal start-up sequence.
3. Wait for the Aviation Database page to be displayed.
4. Verify that the expiration date displayed has not passed.

If the database has expired, then remove and replace the aviation database card as described in the following section, and see Section 1.7.1.

5.7.1 Data Card Replacement

CAUTION



Handle the data cards carefully. Do not touch the connector edge of the data card.

To replace the data card do the following:

4. Ensure that the 400W Series unit is turned off.
5. Remove the data card by lifting the tab and pull card to extract from the unit.
6. With the label facing left, insert the new data cards by pushing the card straight into the slot and press until it is inserted fully. The aviation database card inserts into the left slot. The Terrain database card inserts into the right slot.

5.8 Airplane Flight Manual Supplement Checks

Ensure that the Airplane Flight Manual Supplement (AFMS) is completed and inserted in the Airplane Flight Manual (AFM) or Pilot's Operating Handbook (POH).

1. Fill in the required airplane information in the AFMS.
2. Fill in the appropriate checkbox in the Limitations section of the AFMS corresponding to the type of GPS antenna that was installed.
3. Fill in the appropriate checkbox in the Limitations section of the AFMS corresponding to the autopilot coupling limitations.

NOTE



The GPS SELECT setting will determine if the transition into approach mode is automatic or requires pilot acknowledgement of a message prompt. Refer to GPS SELECT in Section 4.5.1.13 for additional details.

4. Fill in the appropriate checkbox in the Normal Procedures section of the AFMS corresponding to the autopilot mode transitions.
5. Insert the completed AFMS into the AFM or POH.

Table 5-1. GNS 400W Series Post-Installation Checkout Log

GNS 400W Series Post-Installation Checkout Log		Date: ____ / ____ / ____																		
		By: _____																		
INSTALLATION INFORMATION:	Aircraft Model _____	Aircraft Serial # _____																		
	Unit P/N _____	Mod Level _____																		
	Unit Model _____	Serial # _____																		
	GPS Antenna P/N _____	GPS Ant Model _____																		
EXTERNAL ANNUNCIATION REQUIREMENT (See Section 2.5)																				
CDI/HSI SOURCE SELECTION ANNUNCIATION: Annunciation: <input type="checkbox"/> Required <input type="checkbox"/> Not Required <input type="checkbox"/> [<input type="checkbox"/> N/A] Annunciator Installed	GPS NAVIGATION ANNUNCIATION: Annunciation: <input type="checkbox"/> Required <input type="checkbox"/> Not Required <input type="checkbox"/> [<input type="checkbox"/> N/A] Annunciators Installed																			
CONNECTOR ENGAGEMENT CHECK																				
<input type="checkbox"/> Connector engagement checked																				
CONFIGURATION ITEMS:																				
<p>Main ARINC 429 Configuration</p> <p>In 1: <input type="checkbox"/> High <input type="checkbox"/> Low _____</p> <p>In 2: <input type="checkbox"/> High <input type="checkbox"/> Low _____</p> <p>Out: <input type="checkbox"/> High <input type="checkbox"/> Low _____</p> <p>SDI: <input type="checkbox"/> Common <input type="checkbox"/> LNAV 1 <input type="checkbox"/> LNAV 2</p> <p>VNAV: <input type="checkbox"/> Disable Labels <input type="checkbox"/> Enable Labels</p> <p>Main RS-232 Configuration (RX/TX)</p> <p>Chnl 1 _____ / _____</p> <p>Chnl 2 _____ / _____</p> <p>Chnl 3 _____ / _____</p> <p>Chnl 4 _____ / _____</p> <p>Main System Configuration</p> <p>Fuel Type: _____</p> <p>Terrain Type: <input type="checkbox"/> None <input type="checkbox"/> TERRAIN</p> <p>Discretets</p> <p>GPS SELECT: <input type="checkbox"/> Auto <input type="checkbox"/> Prompt</p> <p>COM PRESETS [<input type="checkbox"/> N/A]: <input type="checkbox"/> Enabled <input type="checkbox"/> Disabled</p>	<p>Main Lighting</p> <table style="width: 100%; border: none;"> <thead> <tr> <th style="width: 60%;"></th> <th style="text-align: center; width: 20%;">Display</th> <th style="text-align: center; width: 20%;">Key</th> </tr> </thead> <tbody> <tr> <td>Source:</td> <td style="text-align: center;">_____</td> <td style="text-align: center;">_____</td> </tr> <tr> <td>Resp Time / Min:</td> <td style="text-align: center;">____ / ____</td> <td style="text-align: center;">____ / ____</td> </tr> <tr> <td>Slope / Offset:</td> <td style="text-align: center;">____ / ____</td> <td style="text-align: center;">____ / ____</td> </tr> <tr> <td>Photo Trans %:</td> <td style="text-align: center;">_____</td> <td style="text-align: center;"><input type="checkbox"/> N/A]</td> </tr> <tr> <td>Photo Slp/Ofst:</td> <td style="text-align: center;">____ / ____</td> <td style="text-align: center;"><input type="checkbox"/> N/A]</td> </tr> </tbody> </table> <p>Main CDI / OBS Config</p> <p>OBI Source: <input type="checkbox"/> Always GPS <input type="checkbox"/> Track CDI [<input type="checkbox"/> N/A]</p> <p>V-Flag State: <input type="checkbox"/> Normal <input type="checkbox"/> Declutter</p> <p>SEL CRS for GPS: <input type="checkbox"/> Allow <input type="checkbox"/> Ignore</p> <p>SEL CRS for VLOC: <input type="checkbox"/> Allow <input type="checkbox"/> Ignore</p> <p>CDI Key: <input type="checkbox"/> Allow <input type="checkbox"/> Ignore</p> <p>GPS Vertical Offset</p> <p>GPS Antenna Height Above Ground: _____ ft</p> <p>GAD 42 Configuration [<input type="checkbox"/> N/A]</p> <p>Main RMI/OBI: _____ Roll Steering: _____</p> <p>NAV RMI/OBI: _____ Remote Crs Sel: _____</p> <p>Sel Crs Drive: _____ TAS Input: _____</p> <p>Main RMI/OBI: _____ GPS/NAV 429 L/H: _____</p> <p>Heading 429 L/H: _____</p> <p>GAD SW Ver: _____</p>			Display	Key	Source:	_____	_____	Resp Time / Min:	____ / ____	____ / ____	Slope / Offset:	____ / ____	____ / ____	Photo Trans %:	_____	<input type="checkbox"/> N/A]	Photo Slp/Ofst:	____ / ____	<input type="checkbox"/> N/A]
	Display	Key																		
Source:	_____	_____																		
Resp Time / Min:	____ / ____	____ / ____																		
Slope / Offset:	____ / ____	____ / ____																		
Photo Trans %:	_____	<input type="checkbox"/> N/A]																		
Photo Slp/Ofst:	____ / ____	<input type="checkbox"/> N/A]																		

CONFIGURATION ITEMS (CONT'D):

VOR/LOC/GS CDI (GNS 430W only)

DME Channel Mode: _____

GDL Configuration

N/A]

Attenuation: _____

Model: GDL 69A GDL 69

VOR/LOC/GS ARINC 429 Configuration

(GNS 430W only)

RX Speed: High Low

TX Speed: High Low

SDI: Common VOR/ILS 1 VOR/ILS 2

DME Mode: Directed freq 1 Directed freq 2

After completing configuration and prior to checkout, restart unit for changes to take effect

SYSTEM CHECKOUT

Ground Checks (Configuration Mode)

MAIN ANALOG INDICATOR:

N/A]

- CDI (left, centered, right)
- VDI (down, centered, up)
- TO/FROM flag (OFF, TO, FROM)
- Valid flags
- OBS (Selected Course)

VOR/ILS INDICATOR:

N/A]

- CDI (left, centered, right)
- VDI (down, centered, up)
- TO/FROM flag (OFF, TO, FROM)
- Valid flags

DISCRETE INPUTS:

- N/A] Remote CDI Select
- N/A] Remote OBS Select
- N/A] Terrain Inhibit
- N/A] COM Remote Recall

ADC / ENCODER / FUEL / F/ADC:

- N/A] Air Data Computer
- N/A] Altitude Encoder (serial)
- N/A] Fuel Sensor
- N/A] Fuel / Air Data Computer

ANNUNCIATOR OUTPUTS:

- N/A] Approach (APR)
- N/A] GPS Indicator (GPS)
- N/A] Integrity (INTEG)
- N/A] Message (MSG)
- N/A] OBS Mode (OBS)
- N/A] Terminal Mode (TERM)
- N/A] VLOC Indicator (VLOC)
- N/A] Waypoint (WPT)
- N/A] ILS/GPS Approach (ILS/GPS APR)
- N/A] GPS Select (GPS SELECT)

ALTITUDE ENCODER:

- N/A] Altitude Encoder (Gray code)
- N/A] Altitude Encoder (Serial)

AHRS/IRU/ADC:

- N/A] Air Data Computer
- N/A] AHRS/IRU

GAD 42:

- N/A] GAD 42 Interface Adapter

LIGHTING BUS:

- N/A] Aircraft Lighting Bus

This page intentionally left blank

6. TROUBLESHOOTING

This section provides information to assist troubleshooting if problems occur after completing the installation. Devices connected to the 400W Series unit can be useful for determining whether the 400W Series unit is functioning properly or if there are problems with the installation.

6.1 Troubleshooting Procedure

Table 6-1. Troubleshooting Guide		
Problem	Possible Cause	Solution
The 400W Series unit does not power on.	<ul style="list-style-type: none"> The unit is not getting power to the main connector P4001. 	<ul style="list-style-type: none"> Make sure power is connected to the main 78-pin connector P4001, pins 19 and 20 and ground to P4001, pins 77 and 78. Check circuit breakers and main avionics switch.
The 400W Series unit does not compute a position.	<ul style="list-style-type: none"> Not receiving signals. 	<ul style="list-style-type: none"> Check the GPS antenna connections. Make sure the aircraft is clear of hangars, buildings, trees, etc.
		<ul style="list-style-type: none"> Wait 20 minutes for unit to complete cycle.
GPS signal levels drop when avionics are turned on.	<ul style="list-style-type: none"> Noise interference from other avionics. 	<ul style="list-style-type: none"> Turn all avionics off, then turn on each piece one at a time to isolate the source of the interference. Route GPS cable and locate GPS antenna away from sources of interference.
The GPS signal levels are very low.	<ul style="list-style-type: none"> Improper antenna installation or coax routing. 	<ul style="list-style-type: none"> Check GPS antenna installation, connections, and cable routing. The GPS antenna must be mounted on the top of the aircraft.
	<ul style="list-style-type: none"> Antenna shaded from satellites. 	<ul style="list-style-type: none"> Make sure the aircraft is clear of hangars, buildings, trees, etc.
	<ul style="list-style-type: none"> RF interference at 1575.42 MHz from VHF COM. 	<ul style="list-style-type: none"> Move GPS antenna further from the COM antenna. Add a 1575.42 MHz notch filter in COM coax. Fix or replace the COM. Disconnect the ELT antenna coax to check for possible re-radiation.
The 400W Series unit does not transmit.	<ul style="list-style-type: none"> The PTT input is not being pulled low. 	<ul style="list-style-type: none"> Check that the PTT (mic key) input is pulled low for transmit.
	<ul style="list-style-type: none"> No transmit power to the COM. 	<ul style="list-style-type: none"> Make sure power input is connected to the COM 25-pin connector P4002 11 and 12 and ground to P4002 21 and 22.
	<ul style="list-style-type: none"> The input voltage is too low. 	<ul style="list-style-type: none"> Increase input supply voltage to >12 VDC. (>24VDC for 420 AW and 430AW models)
The sidetone level is too low or too high.	<ul style="list-style-type: none"> Wrong type of headsets, or level needs adjustment. 	<ul style="list-style-type: none"> If necessary, adjust the sidetone level. Sidetone adjustment is found on the COM Setup page.

Table 6-1. Troubleshooting Guide

Problem	Possible Cause	Solution
OBS Resolver won't calibrate.	<ul style="list-style-type: none"> • Incompatible resolver or improper connection. 	<ul style="list-style-type: none"> • Check the resolver specifications and wiring.
OBS indication on 400W Series unit does not agree with OBS setting.	<ul style="list-style-type: none"> • 400W Series unit resolver input not calibrated correctly. • Resolver has not been calibrated. 	<ul style="list-style-type: none"> • Check wiring and calibration.
400W Series unit is not receiving heading from compass system (ARINC 429 heading input used)	<ul style="list-style-type: none"> • ARINC 429 input port speed not correct 	<ul style="list-style-type: none"> • Check ARINC 429 input port speed setting for port that device is connected to and verify that the speed is correct for that device.
	<ul style="list-style-type: none"> • Wiring connections are incorrect. 	<ul style="list-style-type: none"> • Check wiring.
Autopilot is not getting GPSS/Roll Steering data from the 400W Series unit (ARINC 429 Roll Steering used)	<ul style="list-style-type: none"> • 400W Series unit does not have a position or flight plan entered. 	<ul style="list-style-type: none"> • Acquire GPS position and enter a flight plan.
	<ul style="list-style-type: none"> • 400W Series unit ARINC 429 output not configured correctly. 	<ul style="list-style-type: none"> • Check ARINC 429 output port setting for port that autopilot is connected to.
	<ul style="list-style-type: none"> • ARINC 429 output port speed not correct. 	<ul style="list-style-type: none"> • Check ARINC 429 output port speed setting for port that autopilot is connected to and verify that the speed is correct for autopilot.
	<ul style="list-style-type: none"> • Wiring connections are incorrect. 	<ul style="list-style-type: none"> • Check wiring. Must be connected to main GPS 429 output.
RMI pointer does not indicate correctly	<ul style="list-style-type: none"> • Desired RMI source has not been selected. 	<ul style="list-style-type: none"> • Check the OBI source selection on the Main CDI/OBS Config page.
	<ul style="list-style-type: none"> • Wiring connections are incorrect. 	<ul style="list-style-type: none"> • Check wiring.
Tuning data not updating DME	<ul style="list-style-type: none"> • Incorrect configuration. 	<ul style="list-style-type: none"> • Check the DME Channel Mode on the VOR/LOC/GS CDI page.
	<ul style="list-style-type: none"> • Wiring connections are incorrect. 	<ul style="list-style-type: none"> • Check wiring.
ARINC 429 device is not receiving data from the 400W Series unit.	<ul style="list-style-type: none"> • 400W Series unit ARINC 429 output not configured correctly. 	<ul style="list-style-type: none"> • Check ARINC 429 output port setting for port that device is connected to.
	<ul style="list-style-type: none"> • ARINC 429 input port speed not correct 	<ul style="list-style-type: none"> • Check ARINC 429 input port speed setting for port that device is connected to and verify that the speed is correct for that device.
	<ul style="list-style-type: none"> • Wiring connections are incorrect. 	<ul style="list-style-type: none"> • Check wiring.

Table 6-1. Troubleshooting Guide

Problem	Possible Cause	Solution
RS-232 device is not communicating with the 400W Series unit.	<ul style="list-style-type: none">• 400W Series unit RS-232 port not configured correctly.	<ul style="list-style-type: none">• Check RS-232 port setting for port that device is connected to.
	<ul style="list-style-type: none">• Improper setup on the remote device.	<ul style="list-style-type: none">• Verify the configuration of the other device.
	<ul style="list-style-type: none">• Device not compatible, or improper connection.	<ul style="list-style-type: none">• Verify 400W Series unit RX is connected to remote device TX and 400W Series unit TX is connected to remote device Rx.
	<ul style="list-style-type: none">• Multiple TX lines connected together.	<ul style="list-style-type: none">• Verify that there is only one TX source per RX port.
	<ul style="list-style-type: none">• Wiring connections are incorrect.	<ul style="list-style-type: none">• Check wiring
CDI scaling on EFS 40/50 is not correct.	<ul style="list-style-type: none">• On EFS 40/50, FMS #1/#2 configuration is not set to "KLN 90-GPS".	<ul style="list-style-type: none">• Reconfigure EFS 40/50 for "KLN 90-GPS" on FMS #1/#2 inputs, as appropriate.

6.2 Alert Text Troubleshooting Procedure

Table 6-2 is a list of alerts that are relevant to installers. There are additional messages in the 400W/500W Pilot's Guide. If a message is displayed that is not in Table 6-2 or the Pilot's Guide, please contact Garmin technical support.

Table 6-2. Alert Text Troubleshooting Guide

Alert Text	Possible Cause	Solution
Airport database integrity error	<ul style="list-style-type: none"> The 400W Series unit has detected a problem with a database on the NavData card. The message "<database name> database integrity error" indicates the database in error. 	<ul style="list-style-type: none"> The data is not usable. Try reloading the information onto the card. If that does not solve the problem, replace the card.
Basemap database integrity error	<ul style="list-style-type: none"> The 400W Series unit has detected a failure in the built-in basemap (land data) database. Land data does not appear on the Map Page. Other unit functions continue to work normally. 	<ul style="list-style-type: none"> Reload the basemap database
Boot block verify failed - Return unit for repair	<ul style="list-style-type: none"> System integrity testing has determined that the boot block has become corrupted. 	<ul style="list-style-type: none"> Contact Garmin technical support.
CDI key stuck	<ul style="list-style-type: none"> The CDI key is stuck in the enabled (or "pressed") state. Try pressing the CDI key again to cycle its operation. 	<ul style="list-style-type: none"> Contact Garmin technical support.
CDI key disabled	<ul style="list-style-type: none"> "Ignore CDI key" has been selected on the MAIN CDI/OBS CONFIG page. 	<ul style="list-style-type: none"> Go to the MAIN CDI/OBS CONFIG page and deselect "Ignore CDI key"
Check unit cooling	<ul style="list-style-type: none"> The 400W Series unit has detected excessive display backlighting temperature. The backlighting has been automatically dimmed to reduce the temperature. 	<ul style="list-style-type: none"> Check for adequate ventilation or check cooling airflow. Refer to Section 2.7 of the installation manual.
COM has failed (430W only)	<ul style="list-style-type: none"> The unit has detected a failure in its communications transceiver. 	<ul style="list-style-type: none"> Contact Garmin technical support.
COM is not responding (430W only)	<ul style="list-style-type: none"> Internal system-to-system communication between the main processor and the COM transceiver has failed. Operational status of the COM transceiver is unknown. 	<ul style="list-style-type: none"> Contact Garmin technical support If the COM board is still working, it will automatically tune to 121.500 MHz. Transmit and receive functions may still operate regardless of the displayed frequency.
COM needs service (430W only)	<ul style="list-style-type: none"> The unit has detected a failure in its communications transceiver. The COM transceiver may still be usable. 	<ul style="list-style-type: none"> Contact Garmin technical support

Alert Text	Possible Cause	Solution
COM push-to-talk key stuck (430W only)	<ul style="list-style-type: none"> The external push-to-talk (PTT) switch is stuck in the enabled (or “pressed”) state. 	<ul style="list-style-type: none"> Try pressing the PTT switch again to cycle its operation.
	<ul style="list-style-type: none"> Wiring is incorrect. 	<ul style="list-style-type: none"> Check wiring
COM remote transfer key is stuck (430W only)	<ul style="list-style-type: none"> The remote COM transfer switch is stuck in the enabled (or “pressed”) state. 	<ul style="list-style-type: none"> Try pressing the switch again to cycle its operation.
		<ul style="list-style-type: none"> Verify the wiring is correct.
		<ul style="list-style-type: none"> If the message persists, contact Garmin technical support.
COM transfer key stuck (430W only)	<ul style="list-style-type: none"> The COM flip-flop key is stuck in the enabled (or “pressed”) state. 	<ul style="list-style-type: none"> Try pressing the switch again to cycle its operation.
		<ul style="list-style-type: none"> If the message persists, contact Garmin technical support.
COM transmitter power has been reduced (430W only)	<ul style="list-style-type: none"> The unit has detected excessive unit temperature. The COM transceiver transmit power has been automatically reduced to compensate for the condition. 	<ul style="list-style-type: none"> Check for adequate ventilation or check cooling airflow. Refer to Section 2.7 of the installation manual.
	<ul style="list-style-type: none"> Insufficient voltage level 	<ul style="list-style-type: none"> Check the input voltage
Configuration error - Config service req'd	<ul style="list-style-type: none"> The configuration information has been lost or corrupted. 	<ul style="list-style-type: none"> Reconfigure the unit
Data transfer cancelled (crossfill is busy)	<ul style="list-style-type: none"> An attempt to transfer flight plan data during a unit-to-unit crossfill was cancelled. 	<ul style="list-style-type: none"> The host unit is busy. Wait until any previous crossfill operation is complete, before reattempting the transfer.
Data transfer cancelled (data invalid)	<ul style="list-style-type: none"> An attempt to transfer a single user waypoint during a unit-to-unit crossfill was cancelled. No waypoint was specified on the Crossfill Page. 	<ul style="list-style-type: none"> Select a user waypoint and re-attempt the transfer.
Data transfer cancelled (version mismatch)	<ul style="list-style-type: none"> An attempt to transfer data during a unit-to-unit crossfill was cancelled. The database versions of the two 400W Series units are not identical. 	<ul style="list-style-type: none"> If necessary, update the database(s) so they match.
Data transfer error, please re-transmit	<ul style="list-style-type: none"> An error was detected during unit-to-unit crossfill of user data (user waypoints and/or flight plans). 	<ul style="list-style-type: none"> The data transfer should be re-attempted.
Display backlight failure	<ul style="list-style-type: none"> The 400W Series unit has detected a failure in the display backlighting. 	<ul style="list-style-type: none"> Contact Garmin technical support.
Do not use for navigation	<ul style="list-style-type: none"> The 400W Series unit is in Demo Mode and must not be used for actual navigation. 	<ul style="list-style-type: none"> Check that the DEMO MODE SELECT pin is not connected. See section 4.5.1.12.
G/S has failed (430W only)	<ul style="list-style-type: none"> The unit has detected a failure in the glideslope receiver. 	<ul style="list-style-type: none"> Contact Garmin technical support.

Alert Text	Possible Cause	Solution
G/S is not responding (430W only)	<ul style="list-style-type: none"> Internal system-to-system communication between the main processor and the glideslope receiver has failed. Operational status of the glideslope receiver is unknown. 	<ul style="list-style-type: none"> Contact Garmin technical support.
G/S needs service (430W only)	<ul style="list-style-type: none"> The unit has detected a failure in its glideslope receiver. The glideslope receiver may still be usable. 	<ul style="list-style-type: none"> Contact Garmin technical support.
GAD configuration required	<ul style="list-style-type: none"> The GAD 42 Interface Adapter has lost the configuration information stored in its internal memory. Any mechanical indicators connected to your 400W- series unit are unusable. 	<ul style="list-style-type: none"> Reconfigure the GAD 42 unit. Refer the GAD 42 Installation Manual (P/N 190-00159-00)
GAD needs service	<ul style="list-style-type: none"> The 400 Series unit has detected a failure in the GAD 42 interface adapter. Any mechanical indicators connected to your unit are unusable. 	<ul style="list-style-type: none"> Refer to section 5.2.3 of the GAD Installation Manual (P/N 190-00159-00)
GDL 69 is not responding	<ul style="list-style-type: none"> No data is being received from the GDL 69. 	<ul style="list-style-type: none"> Check for proper configuration
		<ul style="list-style-type: none"> Check wiring
		<ul style="list-style-type: none"> Contact Garmin technical support.
GPS is not responding – (main software version 3.11 and earlier) GPS is not responding – check GPS antenna (main software version 3.20 and later).	<ul style="list-style-type: none"> GPS antenna cable is shorted. 	<ul style="list-style-type: none"> Verify that the center conductor is not shorted to the braid in the coaxial cable.
	<ul style="list-style-type: none"> Internal system-to-system communication between the main processor and the GPS receiver has failed. Operational status of the GPS receiver is unknown. 	<ul style="list-style-type: none"> Contact Garmin technical support.
GPS needs service	<ul style="list-style-type: none"> The 400W Series unit has detected a failure in its GPS receiver. 	<ul style="list-style-type: none"> Contact Garmin technical support.
Large magnetic variance	<ul style="list-style-type: none"> A valid value of magnetic variation is not available for this location. 	<ul style="list-style-type: none"> Contact Garmin technical support.
	<ul style="list-style-type: none"> Verify all course angles 	

Alert Text	Possible Cause	Solution
Loss of integrity — cross-check NAV	<ul style="list-style-type: none"> • Improper antenna installation or coax routing 	<ul style="list-style-type: none"> • Check GPS antenna installation, connections, and cable routing. The GPS antenna must be mounted on the top of the aircraft.
	<ul style="list-style-type: none"> • Antenna shaded from satellites 	<ul style="list-style-type: none"> • Make sure the aircraft is clear of hangars, buildings, trees, etc.
	<ul style="list-style-type: none"> • RF interference at 1575.42 MHz from VHF COM. 	<ul style="list-style-type: none"> • Move GPS antenna further from the COM antenna, Add a 1575.42 MHz notch filter in COM coax. Fix or replace the COM. Disconnect the ELT antenna coax to check for possible re-radiation.
Low Battery - Unit Needs Service	<ul style="list-style-type: none"> • Time data may have been lost due to a memory battery failure. 	<ul style="list-style-type: none"> • Replace the battery (refer to section 8.4)
MAIN processor requires service	<ul style="list-style-type: none"> • The 400W-series unit has detected a failure in the main system processor. 	<ul style="list-style-type: none"> • Contact Garmin technical support.
No altitude input is being received	<ul style="list-style-type: none"> • No altitude data is being received from RS-232 (Serializer: Icarus, Rosetta or Shadin) or grey code inputs. 	<ul style="list-style-type: none"> • Refer to Table 6-1 “RS-232 device is not communicating with the GPS 400W/GNS430W”
No basemap data available	<ul style="list-style-type: none"> • The 400W-series unit has detected a failure in the built-in basemap (land data) memory. Land data does not appear on the Map Page. Other unit functions continue to work normally. 	<ul style="list-style-type: none"> • Contact Garmin technical support to reload the basemap data
Not receiving input data on 429 Channel #1 or #2	<ul style="list-style-type: none"> • No data has been received on the ARINC 429 channel #1 connection for a period exceeding five seconds. 	<ul style="list-style-type: none"> • Refer to Table 6-1 “ARINC 429 device is not receiving data from the GPS 400W/GNS 430W”
Not receiving input data on 232 Channel #(1 through 5)	<ul style="list-style-type: none"> • No data has been received on one (or more) of the RS-232 channel connections for a period exceeding ten seconds. 	<ul style="list-style-type: none"> • Refer to Table 6-1 “RS-232 device is not communicating with the 400W/430W”
Not receiving traffic data	<ul style="list-style-type: none"> • No traffic data is being received. 	<ul style="list-style-type: none"> • Check for proper configuration
		<ul style="list-style-type: none"> • Check the wiring • Contact Garmin technical support.
OBS key stuck	<ul style="list-style-type: none"> • The OBS key is stuck in the enabled (or pressed) state. Try pressing the OBS key again to cycle its operation. 	<ul style="list-style-type: none"> • Contact Garmin technical support.

Alert Text	Possible Cause	Solution
OBS not available	<ul style="list-style-type: none"> No destination waypoint has been selected. 	<ul style="list-style-type: none"> Select a waypoint
	<ul style="list-style-type: none"> The GPS receiver cannot currently determine its position. 	<ul style="list-style-type: none"> Refer to Table 6-1 "The 400W Series unit does not compute a position."
RAIM position warning	<ul style="list-style-type: none"> Although sufficient GPS satellite coverage may exist, Receiver Autonomous Integrity Monitoring (RAIM) has determined the information from one or more GPS satellites may be in error. 	<ul style="list-style-type: none"> Wait for GPS satellite geometry to improve.
Searching the sky	<ul style="list-style-type: none"> The 400W Series unit is searching the sky for GPS satellites. 	<ul style="list-style-type: none"> Wait 20 minutes for unit to complete cycle or until the current position is located.
Stored data was lost	<ul style="list-style-type: none"> All user waypoints, flight plans and system settings have been lost due to a memory battery failure or system reset. 	<ul style="list-style-type: none"> If system was not reset replace the battery.
TERRAIN configuration has changed	<ul style="list-style-type: none"> The unit's terrain settings have changed since it was last turned on in normal mode. 	<ul style="list-style-type: none"> Reconfigure TERRAIN settings
		<ul style="list-style-type: none"> Contact Garmin technical support
TERRAIN has failed	<ul style="list-style-type: none"> The unit has detected a failure in the terrain system. 	<ul style="list-style-type: none"> Ensure that Terrain database is inserted in the right most card slot.
		<ul style="list-style-type: none"> Reload the TERRAIN database.
		<ul style="list-style-type: none"> Contact Garmin technical support.
Traffic device has failed	<ul style="list-style-type: none"> The 400W Series unit cannot communicate with the traffic system and/or the traffic system is reporting a system failure. 	<ul style="list-style-type: none"> Check for proper configuration
		<ul style="list-style-type: none"> Check for correct wiring
		<ul style="list-style-type: none"> Refer to the traffic system installation manual.
Traffic device needs service	<ul style="list-style-type: none"> The traffic device is reporting a system failure. 	<ul style="list-style-type: none"> Refer to the traffic system installation manual.
User card format unknown	<ul style="list-style-type: none"> A data card has been inserted, but the format of the card is not recognized. 	<ul style="list-style-type: none"> Reload the information onto the card. If that does not solve the problem replace the card.
VLOC has failed (430W only)	<ul style="list-style-type: none"> The 430W has detected a failure in its VLOC receiver. 	<ul style="list-style-type: none"> Contact Garmin technical support.
VLOC is not responding (430W only)	<ul style="list-style-type: none"> Internal system-to-system communication between the main processor and the VLOC receiver has failed. Operational status of the VLOC receiver is unknown. 	<ul style="list-style-type: none"> Contact Garmin technical support.

Alert Text	Possible Cause	Solution
VLOC needs service (430W only)	<ul style="list-style-type: none"> The unit has detected a failure in its VLOC receiver. The VLOC receiver may still be usable. 	<ul style="list-style-type: none"> Contact Garmin technical support.
VLOC remote transfer key is stuck (430W only)	<ul style="list-style-type: none"> The remote VLOC transfer switch is stuck in the enabled (or “pressed”) state. 	<ul style="list-style-type: none"> Try pressing the switch again to cycle its operation. Contact Garmin technical support.
VLOC transfer key stuck (430W only)	<ul style="list-style-type: none"> The VLOC flip-flop key is stuck in the enabled (or “pressed”) state. 	<ul style="list-style-type: none"> Try pressing the VLOC flip-flop key again to cycle its operation. Contact Garmin technical support.
WX-500 device has failed	<ul style="list-style-type: none"> The 400W- Series unit cannot communicate with the WX-500. 	<ul style="list-style-type: none"> Check for proper configuration
	<ul style="list-style-type: none"> The WX-500 is reporting a system failure. 	<ul style="list-style-type: none"> Check the wiring
		<ul style="list-style-type: none"> Refer to the WX-500 installation manual for additional troubleshooting information.
WX-500 heading has failed	<ul style="list-style-type: none"> The WX-500 is reporting invalid heading data. 	<ul style="list-style-type: none"> Check for proper configuration of WX-500
		<ul style="list-style-type: none"> The failure may be within the WX-500 or other connected equipment.

6.3 Contacting the Factory for Assistance

If the 400W Series unit fails to operate despite troubleshooting efforts, contact Garmin Technical Support for assistance.

GARMIN International, Inc.
1200 East 151st Street
Olathe, KS 66062-3426
USA
Phone: 913.397.8200
FAX: 913.397.8282
<http://www.garmin.com>

Be prepared to offer the following information about the installation:

- Installation configuration (list of any accessories)
- Model number, part number with mod levels, and serial number
- Software Versions
- Description of problem
- Efforts made to isolate the problem

This page intentionally left blank

7. LIMITATIONS

7.1 Operations

There are no Part 23 aircraft type limitations. All functions of the 400W Series unit meet the appropriate design assurance qualifications for primary or secondary for airplane Class I, Class II, Class III, and Class IV in accordance with AC 23.1309-1C Figure 2. The TSO authorizations with the RTCA/DO178B software levels by function are listed in Table 1-4.

7.1.1 TSO-C146a GPS/WAAS Limitations

Due to the equipment's TSO qualified performance in tracking low-elevation-angle satellites, operational limitations may be required based upon the GPS antenna or GPS software used in the installation. If AML STC SA01933LA is used as the basis for approval, the appropriate limitations are included in the AFMS provided with the STC. However, if other airworthiness approval is obtained, the following limitations must be included in the Aircraft Flight Manual or Aircraft Flight Manual Supplement if an antenna listed in Table 1-3 or GPS software version 2.X is used:

NOTE



The limitations below do not apply to VFR-only installations and as such do not need to be included in the AFM/AFMS.

The equipment does not comply with US 14 CFR part 91, SFAR 97 requirements for TSO-C146a equipment. Until complete compliance is demonstrated and approved by the FAA, authorization to conduct any GPS or WAAS operation under Instrument Flight Rules (IFR) requires that:

- 1) Aircraft using the GPS or WAAS capability of the 400W Series navigation equipment under IFR must be equipped with an approved and operational alternate means of navigation appropriate to the flight, with the exception of oceanic and remote operations.
- 2) For flight planning purposes, if an alternate airport is required, it must have an approved instrument approach procedure other than GPS or RNAV that is anticipated to be operational and available at the estimated time of arrival. All equipment required for this procedure must be installed and operational.
- 3) For flight planning purposes, Garmin Prediction Program part number 006-A0154-03 (with the **<insert installed antenna model number/part number>** antenna selected) should be used to confirm the availability of RAIM for the intended flight in accordance with the local aviation authority guidelines for TSO-C129a equipment. WAAS NOTAMs (or their absence) and generic prediction tools do not provide an acceptable indication of the availability for the 400W Series equipment.
- 4) When flight planning an LNAV/VNAV or LPV approach, operators should use the Garmin Prediction Program part number 006-A0154-03 (with the **<insert installed antenna model number/part number>** antenna selected) in addition to any NOTAMs issued for the approach.

NOTE



Garmin Prediction Program part number 006-A0154-03 is contained on the 400W/500W Trainer CD, P/N 010-10601-00.

7.1.2 Safety Assessment Considerations

This STC requires that the modified aircraft meet navigation and communication availability requirements at the aircraft level appropriate to the failure condition category, aircraft category and class.

TSO-C146a defines loss of function of en route, terminal, non-precision approach, or precision approach navigation data as a major failure condition. AC 23.1309-1C provides guidance for IFR airplanes that classifies total loss of function as a major failure condition, and loss of primary means of function as minor if two navigation systems are installed. One method to meet the major failure condition for loss of function is to have redundant systems. It is recommended that the aircraft be equipped with at least two independent navigation receivers and two independent communication transceivers for IFR use. For independent navigation systems, two 400W Series units may be used, or a combination of 400W/500W Series and an independent NAV/COM unit may be used. This will support System Safety Assessment of assumptions. Refer to AC 23.1309-1C.

7.1.3 Previous Operational Approvals

The installation of a 400W Series unit into an aircraft does not alter the operational approvals previously granted to that aircraft. Additional operation approvals may require FAA evaluation of all the systems installed in a particular aircraft and is outside the scope of 400W/500W Series STC SA01933LA.

7.2 Installation

The conditions and tests required for TSO approval of this article are minimum performance standards. It is the responsibility of those installing this article either on or within a specific type or class of aircraft to determine that the aircraft installation conditions are within the TSO standards. TSO articles must have separate approval for installation in an aircraft. The article may be installed only if performed under 14 CFR part 43 or the applicable airworthiness requirements.

The 400W Series GPS/WAAS receiver, when installed with the appropriate antenna listed in Section 1.4.8, is compatible with aircraft equipped with SATCOM when installed in accordance to this manual.

7.2.1 GPS Antenna

The GPS/WAAS receiver is compatible with the GPS antennas listed in Section 1.4.8. Antenna selection may affect operational limitations.

7.2.2 Antenna Installation – General

Structural mounting of the GPS/WAAS antenna is not included in this installation manual. For mounting the GPS/WAAS antennas, refer to the Garmin GA Antenna AML STC SA01695SE or other FAA approved installation data.

7.2.3 Equipment Interfaced to the 400W Series Unit

400W Series unit interfaces to aircraft systems other than those identified in this installation manual are outside the scope of this manual and may require further evaluation for certification and/or other FAA airworthiness approval.

7.2.4 Preservation of Previous Systems

It is the installer's responsibility using data provided in this manual identified in 400W/500W Series AML STC SA01933LA to preserve the essential characteristics of the aircraft in accordance with the aircraft manufacturer's original design and the requirements of 14 CFR Part 23. This includes the preservation of multiple power buses, which reduce the probability of interrupting power to essential instruments and avionics. For aircraft certified under 14 CFR Part 23, post amendment 41, use of the 400W Series unit for IFR operations requires a functional redundant electrical power system for the primary navigation unit.

7.3 Rotorcraft Installation

The installation and operational approval for use of a 400W Series unit in rotorcraft is not covered by AML STC SA01933LA; however, instructions and data provided in this manual may be used to perform the alteration and obtain other FAA approval.

The 400W Series unit TERRAIN functionality is not recommended for use in rotorcraft.

7.4 Aircraft Radio Station License

An aircraft radio station license is not required when operating in U.S. airspace, but may be required when operating internationally.

This page intentionally left blank

8. PERIODIC MAINTENANCE

8.1 Equipment Calibration

No scheduled servicing tasks are required on the 400W Series unit.

8.2 VOR Checks

Refer to CFR 14 paragraph 91.171. Every 30 days verify the limits of the permissible indicated bearing error.

8.3 Cleaning

The front bezel, keypad, and display can be cleaned with a soft cotton cloth dampened with clean water. DO NOT use any chemical cleaning agents. Care should be taken to avoid scratching the surface of the display.

8.4 Battery Replacement

WARNING



This product contains a Lithium battery that must be recycled or disposed of properly. Battery replacement and removal must be performed by professional services.

The 400W Series unit includes an internal battery that will last 5 to 8 years. The battery is used for internal time clock and GPS system information. Regular planned replacement is not necessary. The 400W Series unit will display a “Low Battery” and “Unit Needs Service” message when replacement is required. Once the low battery message is displayed, the battery should be replaced within 1 to 2 months.

If the battery is not replaced and becomes totally discharged, the 400W Series unit will remain fully operational, but the GPS signal acquisition time will be increased. There is no loss of function or accuracy of the 400W Series unit with a dead battery.

The battery is not user replaceable. To replace the battery, contact the Garmin repair station or factory authorized repair station.

This page intentionally left blank

Appendix A ENVIRONMENTAL QUALIFICATION FORM

For RTCA/DO-160D Environmental Qualification Forms (EQFs) visit the Dealers Only page on <http://www.garmin.com>. The part numbers for each form are listed below.

Table A-1. Environmental Qualification Form Part Numbers

Unit	EQF Part Number
GPS 400W	005-00221-08
GNC 420W	005-00221-47
GNC 420AW	005-00221-48
GNS 430W	005-00221-49
GNS 430AW	005-00221-50

This page intentionally left blank

Appendix B STC DATA

B.1 STC Information

The 400W/500W Series STC SA01933LA with Approved Model List (AML) and Master Data List (P/N 005-C0221-00) information is available on the Garmin web site at www.garmin.com and can be downloaded from the Dealers Only page.

B.2 Permission to use STC

Consistent with Order 8110.4B and AC 21-40, a permission letter to use this STC data is available for download on the Dealers Only portion of the Garmin website at www.garmin.com.

B.3 Continued Airworthiness Instructions

Refer to the 400W Series Instructions for Continued Airworthiness (P/N 190-00356-65).

B.4 STC Approved Model List

The 400W/500W Series STC SA01933LA Approved Model List (AML) includes airplanes that are type certificated only under CAR 3 or 14 CFR Part 23. The Garmin 400W Series unit equipment is approved for installation on all aircraft listed on the AML when adhering to the installation instructions and the limitations described in this 400W Series Installation Manual. The AML is attached to STC SA01933LA and may be downloaded from the Garmin web site at www.garmin.com.

This page intentionally left blank

Appendix C RESERVED

This page intentionally left blank

Appendix D 400W SERIES RS-232 AVIATION DATA FORMAT

D.1 Electrical Interface

The output signals are compatible with RS-232C. Data is generated at 9600 baud with a word length of 8 bits, one stop bit, and no parity.

D.2 General Output Format

The 400W Series RS-232 data has the following general format:

STX - ASCII start-of-text character (02 hex)

t1s - Type 1 output sentences (see following paragraphs for description)

t2s - One or more type 2 output sentences (see following paragraphs for description)

ETX - ASCII end-of-text character (03 hex)

D.3 Output Sentence Type 1

The Type 1 output sentences have the following general format:

id - item designator (single ASCII alphabetic character)

dddd - item data (1 to 10 printable ASCII characters)

CR - ASCII carriage return character (0D hex)

LF - ASCII line feed character (0A hex)*

Each Type 1 sentence is output by the 400W Series unit approximately once every second.

The track, desired track, and bearing to waypoint angles, and the magnetic variation are output according to the current mode of the 400W Series unit (automatic magnetic heading, magnetic variation computed at last known position; true heading, magnetic variation of E00.0°; or user-defined magnetic heading, magnetic variation as entered by user).

Table D-1 describes the Type 1 output sentence item designator (id) and item data (dddd) fields. If data for these sentences is invalid or unavailable, dashes ("-") are used to fill in all non-blank character positions.

Table D-1. Type 1 Output Sentence Format

Ident (1 byte)	Data (10 bytes)	Description
	1 2 3 4 5 6 7 8 9 0	
Z	a a a a a	Current GPS altitude in feet *
A	s d d m m h h	Current latitude, where: s - N (north) or S (south) dd - degrees mm - minutes hh - hundredths of minutes
B	s d d d m m h h	Current longitude, where: s - E (east) or W (west) ddd - degrees mm - minutes hh - hundredths of minutes
C	d d d	Track in whole degrees
D	s s s	Ground speed in knots
E	d d d d d	Distance to waypoint in tenths of nautical miles
G	s n n n n	Cross track error, where: s - L (left) or R (right) of course nnnn - error in hundredths of nautical miles
I	d d d d	Desired track in tenths of degrees
K	c c c c c	Destination waypoint identifier (will be blank filled on right if less than 5 characters in identifier)
L	d d d d	Bearing to destination waypoint in tenths of degrees
Q	s d d d	Magnetic variation, where: s - E (east) or W (west) ddd - tenths of degrees
S	- - - - f	NAV valid flag status, where: f - N (nav flagged) or - (nav valid)
T	- - - - - - - - -	Warnings status, only data transmitted are dashes (-). Used to indicate end of Type 1 sentences.
l (lower case Lima)	d d d d d d	Distance to destination waypoint in tenths of nautical miles.

* The line feed character is not output if the RS-232 port is configured as "Avtn no alt".

* The altitude is not output if the RS-232 port is configured as "Avtn no alt".

D.4 Output Sentence Type 2

The 400W Series Type 2 output sentences have the following general format:

- id - item designator (3 ASCII characters)
- seq - sequence number (1 binary byte)
- wpt - waypoint identifier (5 ASCII characters)
- lat - waypoint latitude (3 binary bytes)
- lon - waypoint longitude (4 binary bytes)
- mvar - magnetic variation at waypoint (2 binary bytes)
- CR - ASCII carriage return character (0D hex)
- LF - ASCII line feed character (0A hex)

Each waypoint in the route being navigated by the 400W Series unit has a Type 2 sentence output by the 400W Series unit approximately once every second.

If no route is being navigated by the 400W Series unit (i.e., the active route is empty), the following Type 2 sentence is output approximately once every second:

- id - item designator (3 ASCII characters; route sequence number is "01")
- seq - sequence number (1 binary byte; last waypoint flag is set; route sequence number is 1)
- CR - ASCII carriage return character (0D hex)
- LF - ASCII line feed character (0A hex)

Table D-2 describes the Type 2 output sentence item designator (id), sequence number (seq), waypoint identifier (wpt), waypoint latitude (lat), waypoint longitude (lon), and magnetic variation at waypoint (mvar) fields.

Table D-2. Type 2 Output Sentence Format

Field	Byte	Format	Description
		7 6 5 4 3 2 1 0	
id	1		ASCII character 'w' (77 hex)
	2-3		Two ASCII numeric characters representing route sequence number of waypoint (01 to 31)
seq	1	x l a n n n n n n	x - undefined l - 1 if last waypoint in route a - 1 if active to waypoint nnnnn - route sequence number of waypoint (unsigned binary)
wpt	1-5		Destination waypoint identifier (will be blank filled on right if less than 5 characters in identifier)
lat	1	s d d d d d d d	s - 0 (north) or 1 (south) ddddddd - latitude degrees (unsigned binary)
	2	x x m m m m m m	xx - undefined mmmmm - latitude minutes (unsigned binary)
	3	x h h h h h h h	x - undefined hhhhhh - hundredths of latitude minutes (unsigned binary)
lon	1	s x x x x x x x	s - 0 (east) or 1 (west) xxxxxxx - undefined
	2	d d d d d d d d	ddddddd - longitude degrees (unsigned binary)
	3	x x m m m m m m	xx - undefined mmmmm - latitude minutes (unsigned binary)
	4	x h h h h h h h	x - undefined hhhhhh - hundredths of latitude minutes (unsigned binary)
mvar	1-2		Two's complement binary in 16ths of degrees. Easterly variation is positive. MSB output first.

Appendix E 400W SERIES RS-232 FUEL/AIR DATA INPUT FORMAT

E.1 Electrical Interface

The input signals are compatible with RS-232C. Data input is at 9600 baud with a word length of 8 bits, one stop bit, and no parity. One message is received per second.

E.2 Shadin Altitude Sentence

The Garmin 400W Series units are capable of receiving the following 17-byte message from Shadin Altitude Encoders, Altitude Serializers, and Altitude Converters:

RMS<sp><+/->12345T<+/->12ul<CR>

Where:

RMS ASCII characters
<sp> space (0x20)
<+/-> sign indicator (0x2b["+"] or 0x2d["-"])
12345 altitude in feet
T ASCII character
<+/-> sign indicator
12 sensor temperature
ul checksum of bytes 1 through 14 in hex ASCII (i.e., "FA")
<CR> carriage return (0x0d)

Note: Checksum is calculated by adding each byte in the message (1 through 14).

E.3 Icarus Altitude Sentence

The Garmin 400W Series units are capable of receiving the following 10-byte message from the Icarus Altitude Serializer:

ALT<sp>12345<CR>

Where:

ALT ASCII characters
<sp> space (0x20)
12345 altitude in feet
<CR> carriage return (0x0d)

E.4 Shadin Fuel Flow Sentence

The Garmin 400W Series units are capable of receiving the following 55-byte message from the Shadin Fuel Flow Indicator:

<STX>K0543.2<sp>0100.0<sp>0040.0<sp>0060.0<sp>0123.4<sp>0045.4<sp>0078.0<sp>123<ETX>

Where:

- <STX> start-transmit character (0x02)
- K units designation (i.e., **G**allons, **L**iters, **K**ilograms, **B**[pounds])
- 0543.2 total fuel remaining (i.e., ASCII-coded decimal format: 0x30, 0x35, 0x34, 0x33, 0x2e, 0x32)
- <sp> space (0x20)
- 0100.0 fuel flow rate, total (formatted as for total fuel remaining)
- 0040.0 fuel flow rate, engine one (or asterisks["*****"], in the case of single engine aircraft)
- 0060.0 fuel flow rate, engine two (asterisks, in the case of single engine aircraft)
- 0123.4 fuel used, total
- 0045.4 fuel used, engine one (asterisks, in the case of single engine aircraft)
- 0078.0 fuel used, engine two (asterisks, in the case of single engine aircraft)
- 123 checksum (of bytes 2 through 51)
- <ETX> end-transmit character (0x03)

Note: Checksum is calculated by adding each byte in the message (2 through 51), such that carries are discarded to give a one byte result. The ASCII-coded decimal representation of that byte is given, ranging from 0 (0x30, 0x30, 0x30) to 255 (0x32, 0x35, 0x35).

E.5 ARNAV / EI Fuel Flow Sentence

The Garmin 400W Series units are capable of receiving the following 13-byte message from the ARNAV or Electronics International ("EI") Fuel Flow Indicators:

<STX>G0245100550<ETX>

Where:

- <STX> start-transmit character (0x02 hex)
- G units designation (i.e., **G**allons, **I**mperial gallons, **L**iters, **K**ilograms, **B**[pounds])
- 0245 total fuel remaining in reverse order (i.e., ASCII-coded decimal format: 0x30, 0x32, 0x34, 0x35)
- 1 fuel remaining checksum (modulo 10 sum of four "total fuel remaining" digits)
- 0055 total fuel flow rate in reverse order
- 0 fuel flow checksum
- <ETX> end-transmit character (0x03)

NOTE: Fuel remaining and fuel flow are [$\times 10$] when units designation is gallons or imperial gallons. For example, 0245 gallons indicates 542 gallons; 0245 liters indicates 5420 liters. Checksum is the modulo 10 sum of the four fuel flow decimal digits, converted to an ASCII numerical character (e.g., checksum for "5678" would be ASCII "6").

E.6 Shadin Fuel/Air Data Computer Sentence

The Garmin 400W Series units are capable of receiving the following message strings from the Shadin Fuel/Airdata or Airdata Computer:

SHADIN “z” FORMAT

<STX>

ZA012<CR><LF>	"ZA" (ASCII characters); "012" represents indicated Air Speed (knots)
ZB345<CR><LF>	"ZB" (ASCII characters); "345" represents true Air Speed (knots)
ZC678<CR><LF>	"ZC" (ASCII characters); "678" represents Mach Speed (thousandths)
ZD<+/->9012<CR><LF>	"ZD" (ASCII characters); sign; "9012" represents pressure altitude (tens of feet)
ZE<+/->3456<CR><LF>	"ZE" (ASCII characters); sign; "3456" represents density altitude (tens of feet)
ZF<+/->78<CR><LF>	"ZF" (ASCII characters); sign; "78" represents outside air temperature (Celsius)
ZG<+/->90<CR><LF>	"ZG" (ASCII characters); sign; "90" represents true air temperature (Celsius)
ZH123<CR><LF>	"ZH" (ASCII characters); "123" represents wind direction (degrees from north)
ZI456<CR><LF>	"ZI" (ASCII characters); "456" represents wind speed (knots)
ZJ<+/->78<CR><LF>	"ZJ" (ASCII characters); sign; "78" represents rate of turn (degrees per second)
ZK<+/->901<CR><LF>	"ZK" (ASCII characters); sign; "901" represents vertical speed (tens of ft/minute)
ZL234<CR><LF>	"ZL" (ASCII characters); "234" represents heading (degrees from north)
ZM5678<CR><LF>†	"ZM" (ASCII characters); "5678" represents fuel flow, right (tenths gallons/hour)
ZN90123<CR><LF>†	"ZN" (ASCII characters); "90123" represents fuel used, right (tenths gallons)
ZO4567<CR><LF>†	"ZO" (ASCII characters); "4567" represents fuel flow, left (tenths gallons/hour)
ZP89012<CR><LF>†	"ZP" (ASCII characters); "89012" represents fuel used, left (tenths gallons)
ZQ345<CR><LF>	"ZQ" (ASCII characters); "345" represents error log/reason indicator
ZR678<CR><LF>	"ZR" (ASCII characters); "678" represents checksum

<ETX>

Where:

- <STX> start-transmit character (0x02)
- <CR> carriage-return character (0x0d)
- <LF> line-feed character (0x0a)
- <+/-> sign indicator (0x2b["+"] or 0x2d["-"])
- <ETX> end-transmit character (0x03)

† Not available from Air Data Computer

Note: Checksum is calculated by adding each byte in the message (including all characters from <STX> up to and including the error log/reason indicator), such that carries are discarded to give a one byte result. The ASCII-coded decimal representation of that byte is given, ranging from 0 (0x30, 0x30, 0x30) to 255 (0x32, 0x35, 0x35).

SHADIN "G" FORMAT

<STX>

GA012<CR><LF>	"GA" (ASCII characters); "012" represents indicated Air Speed (knots)
GB345<CR><LF>	"GB" (ASCII characters); "345" represents true Air Speed (knots)
GC678<CR><LF>	"GC" (ASCII characters); "678" represents Mach Speed (thousandths)
GD<+/->9012<CR><LF>	"GD" (ASCII characters); sign; "9012" represents pressure altitude (tens of feet)
GE<+/->3456<CR><LF>	"GE" (ASCII characters); sign; "3456" represents density altitude (tens of feet)
GF<+/->78<CR><LF>	"GF" (ASCII characters); sign; "78" represents outside air temperature (Celsius)
GG<+/->90<CR><LF>	"GG" (ASCII characters); sign; "90" represents true air temperature (Celsius)
GH123<CR><LF>	"GH" (ASCII characters); "123" represents wind direction (degrees from north)
GI456<CR><LF>	"GI" (ASCII characters); "456" represents wind speed (knots)
GJ<+/->78<CR><LF>	"GJ" (ASCII characters); sign; "78" represents rate of turn (degrees per second)
GK<+/->901<CR><LF>	"GK" (ASCII characters); sign; "901" represents vertical speed (tens of ft/minute)
GL234<CR><LF>	"GL" (ASCII characters); "234" represents heading (degrees from north)
GM5678<CR><LF>†	"GM" (ASCII characters); "5678" represents fuel flow, right (Twin only) (tenths gallons/hour)
GN90123<CR><LF>†	"GN" (ASCII characters); "90123" represents fuel used, right (Twin only) (tenths gallons)
GO4567<CR><LF>	"GO" (ASCII characters); "4567" represents fuel flow, left (or Single) (tenths gallons/hour)
GP89012<CR><LF>	"GP" (ASCII characters); "89012" represents fuel used, left (or Single) (tenths gallons)
GQ001<CR><LF>	"GQ" (ASCII characters); "001" represents error log/reason indicator (001 = temp. sensor error, 000 = no errors)
GR6789.0<CR><LF>†	"GR" (ASCII characters); "6789.0" represents fuel remaining (gallons)
Ga<+/->1234<CR><LF>	"Ga" (ASCII characters); sign; "12.34" represents barometric corrected altitude (tens of feet)
Gb56.78<CR><LF>	"Gb" (ASCII characters); "56.78" represents current barometric pressure setting (inches Hg)
G*901<CR><LF>	"G*" (ASCII characters); "901" represents checksum

<ETX>

Where:

- <STX> start-transmit character (0x02)
- <CR> carriage-return character (0x0d)
- <LF> line-feed character (0x0a)
- <+/-> sign indicator (0x2b["+"] or 0x2d["-"])
- <ETX> end-transmit character (0x03)

† Not available from Airdata Computer

Note: Checksum is calculated by adding each byte in the message (including all characters from <STX> up to and including the error log/reason indicator), such that carries are discarded to give a one byte result. The ASCII-coded decimal representation of that byte is given, ranging from 0 (0x30, 0x30, 0x30) to 255 (0x32, 0x35, 0x35).

SHADIN “S” FORMAT

<STX>	
SA012<CR><LF>	"SA" (ASCII characters); "012" represents indicated Air Speed (knots)
SB345<CR><LF>	"SB" (ASCII characters); "345" represents true Air Speed (knots)
SC678<CR><LF>	"SC" (ASCII characters); "678" represents Mach Speed (thousandths)
SD<+/->9012<CR><LF>	"SD" (ASCII characters); sign; "9012" represents pressure altitude (tens of feet)
SE<+/->3456<CR><LF>	"SE" (ASCII characters); sign; "3456" represents density altitude (tens of feet)
SF<+/->78<CR><LF>	"SF" (ASCII characters); sign; "78" represents outside air temperature (Celsius)
SG<+/->90<CR><LF>	"SG" (ASCII characters); sign; "90" represents true air temperature (Celsius)
SH123<CR><LF>	"SH" (ASCII characters); "123" represents wind direction (degrees from north)
SI456<CR><LF>	"SI" (ASCII characters); "456" represents wind speed (knots)
SJ<+/->78<CR><LF>	"SJ" (ASCII characters); sign; "78" represents rate of turn (degrees per second)
SK<+/->901<CR><LF>	"SK" (ASCII characters); sign; "901" represents vertical speed (tens of ft/minute)
SL234<CR><LF>	"SL" (ASCII characters); "234" represents heading (degrees from north)
SM5678<CR><LF>	"SM" (ASCII characters); "5678" represents fuel flow, right (tenths gallons/hour)
SN90123<CR><LF>	"SN" (ASCII characters); "90123" represents fuel used, right (tenths gallons)
SO4567<CR><LF>	"SO" (ASCII characters); "4567" represents fuel flow, left (tenths gallons/hour)
SP89012<CR><LF>	"SP" (ASCII characters); "89012" represents fuel used, left (tenths gallons)
SQ345<CR><LF>	"SQ" (ASCII characters); "345" represents error log/reason indicator
SR67890<CR><LF>	"SR" (ASCII characters); "67890" represents fuel remaining (tenths gallons)
SS123<CR><LF>	"SS" (ASCII character); "123" represents ground speed (knots)
ST456<CR><LF>	"ST" (ASCII character); "456" represents track (degrees)
SU789012<CR><LF>	"SU" (ASCII character); "789012" represents distance to waypoint (hundredths nautical miles)
SV<E/W>345<CR><LF>	"SV" (ASCII character); "E" represents East, "W" represents West; "345" represents magnetic variation (tenths degrees)
SW<N/S>67 8901<CR><LF>	"SW" (ASCII character); "N" represents North, "S" represents South; "67 8910" represents current latitude (degrees, minutes, hundredths of minutes)
SX<E/W>234 5678<CR><LF>	"SX" (ASCII character); "E" represents East, "W" represents West; "234 5678" represents current longitude (degrees, minutes, hundredths of minutes)
SY<L/R>90<CR><LF>	"SY" (ASCII character); "L" represents Left, "R" represents Right; "90" represents drift angle (degrees)
Sa<+/->1234<CR><LF>	"Sa" (ASCII character); sign; "1234" represents barometric corrected altitude (tens of feet)
Sb56.78<CR><LF>	"Sb" (ASCII character); "56.78" represents current barometric pressure setting (inches Hg)
S*901<CR><LF>	"S*" (ASCII character); "901" represents checksum
<ETX>	

Where:

- <STX> start-transmit character (0x02)
- <CR> carriage-return character (0x0d)
- <LF> line-feed character (0x0a)
- <+/-> sign indicator (0x2b["+"] or 0x2d["-"])
- <ETX> end-transmit character (0x03)

Note: Checksum is calculated by adding each byte in the message (including all characters from <STX> up to and including the error log/reason indicator), such that carries are discarded to give a one byte result. The ASCII-coded decimal representation of that byte is given, ranging from 0 (0x30, 0x30, 0x30) to 255 (0x32, 0x35, 0x35).

This page intentionally left blank

Appendix F MECHANICAL DRAWINGS

F.1 Drawing List

The following drawings are included in this section.

- Figure F-1. 400W Series Mounting Rack Dimensions
- Figure F-2. GNS 430W Mounting Rack Installation
- Figure F-3. GNC 420W Mounting Rack Installation
- Figure F-4. GPS 400W Mounting Rack Installation
- Figure F-5. 400W Series Recommended Panel Cutout Dimensions

This page intentionally left blank

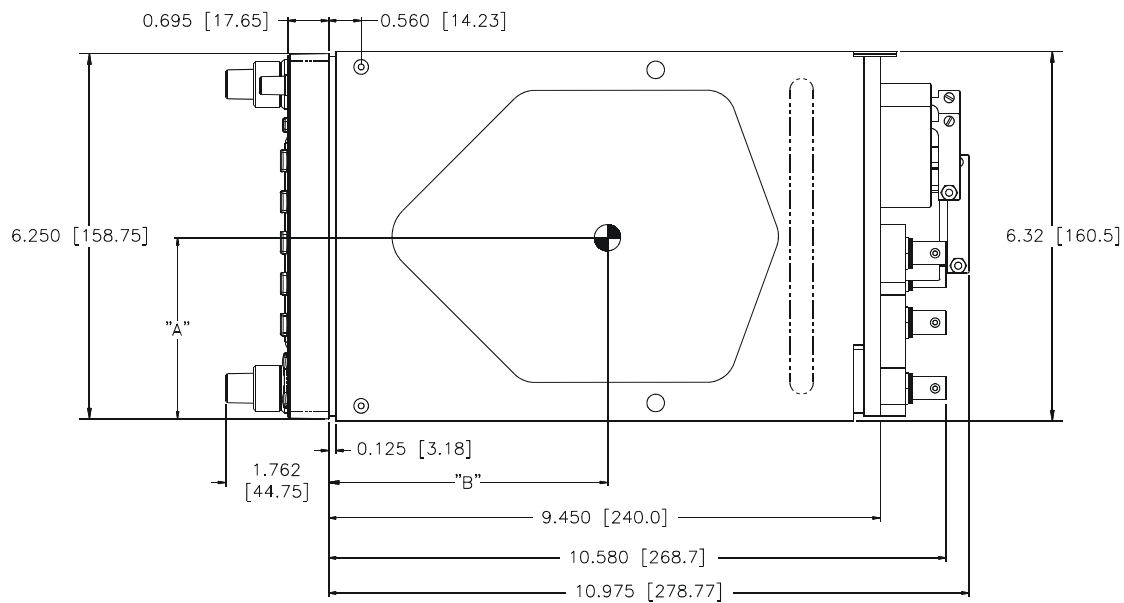

GNS 430W SHOWN

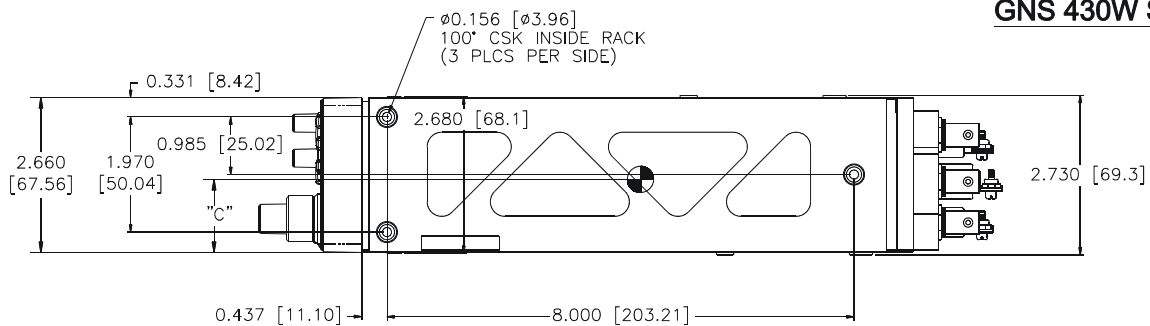

DIMENSIONS			
MODEL	A	B	C
GPS 400W	2.85 [72.4]	4.6 [117]	1.2 [30.5]
GNC 420W	3.05 [77.5]	4.8 [122]	1.3 [33]
GNS 430W	3.05 [77.5]	4.9 [124]	1.4 [35.6]

NOTES:

1. DIMENSIONS: INCH [mm].
2. CG LOCATION INCLUDES UNIT WITH MOUNTING RACK AND BACK PLATE ASSEMBLY.

Figure F-1. 400W Series Mounting Rack Dimensions

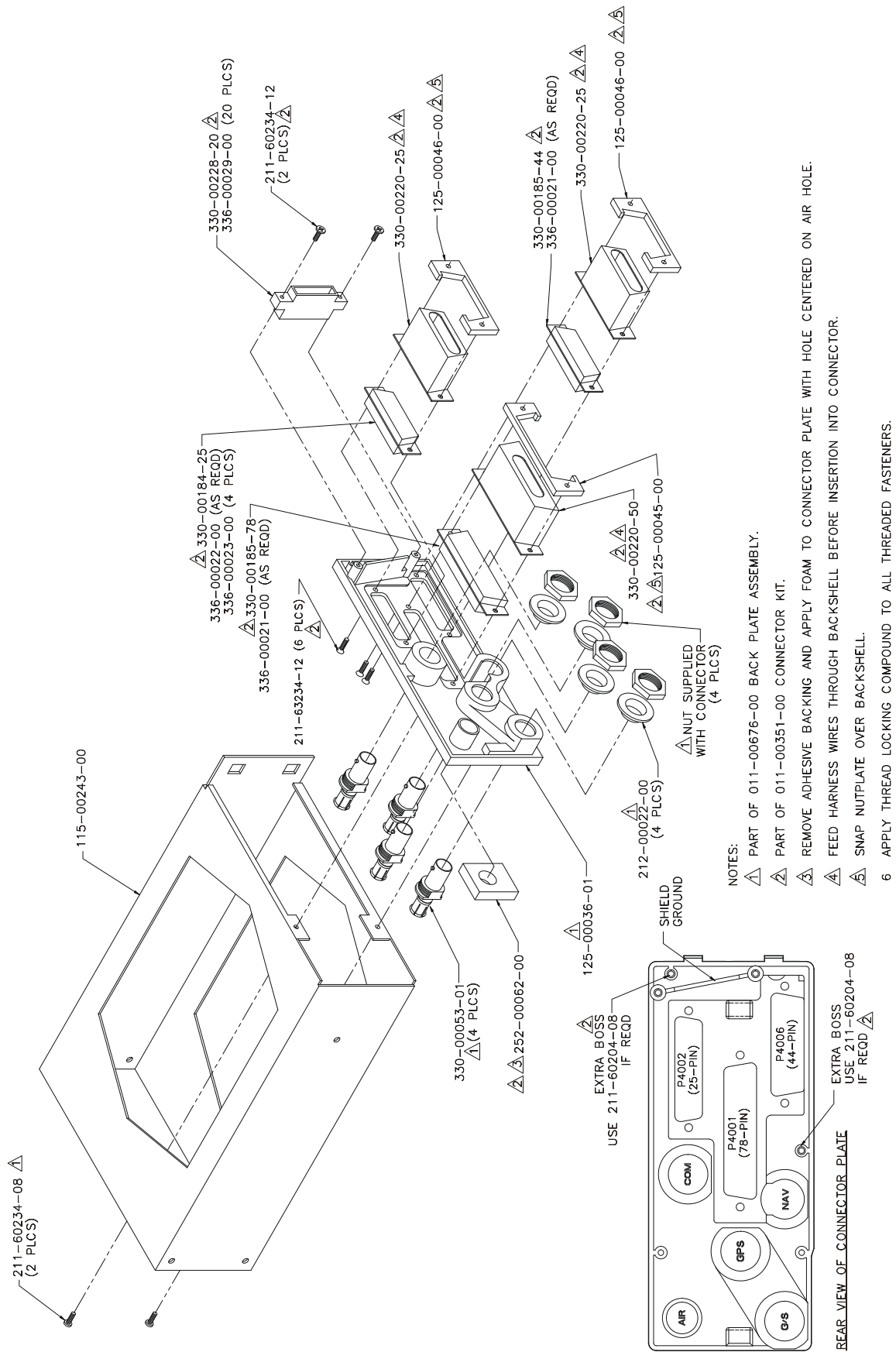

Figure F-2. GNS 430W Mounting Rack Installation

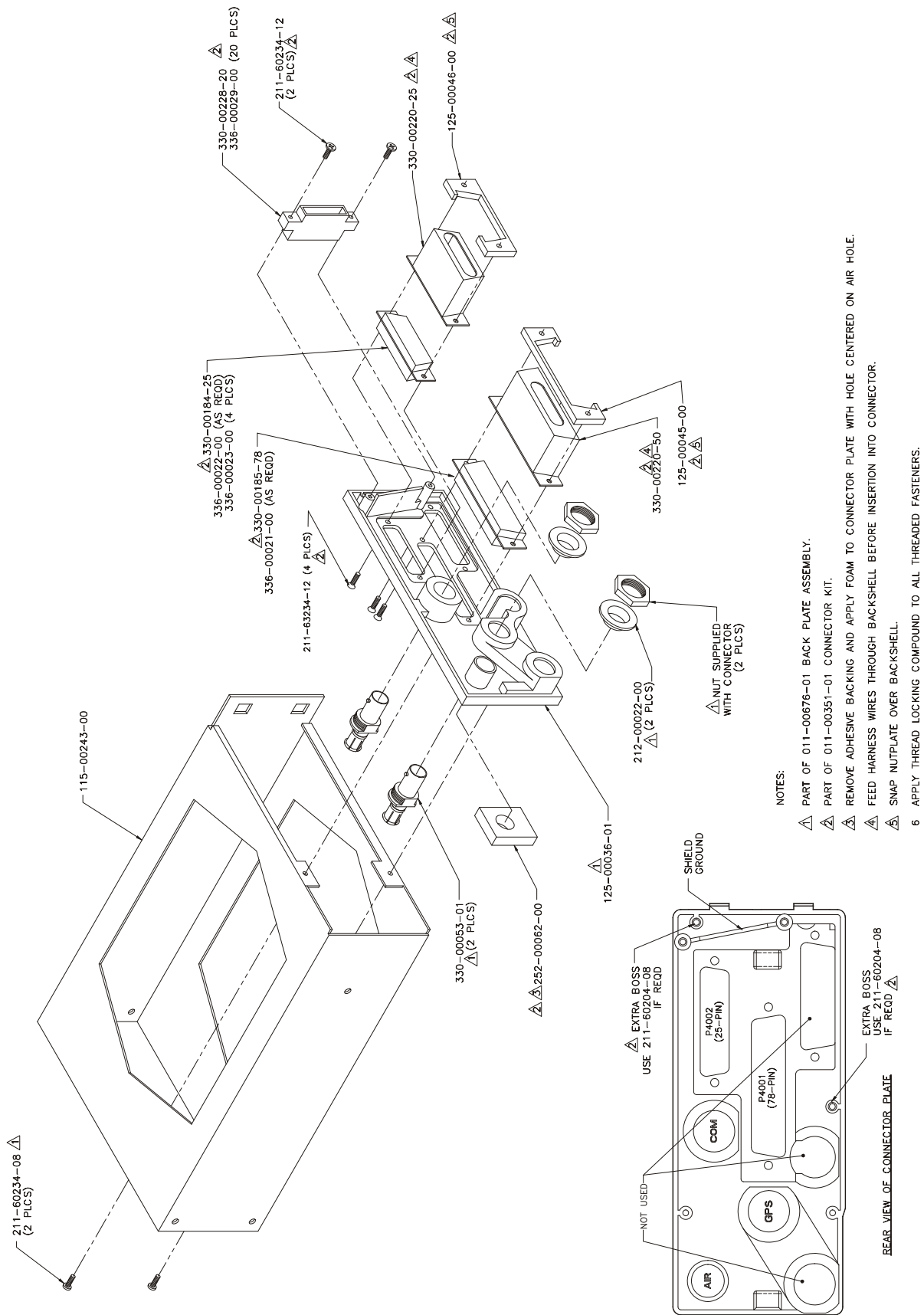

Figure F-3. GNC 420W Mounting Rack Installation

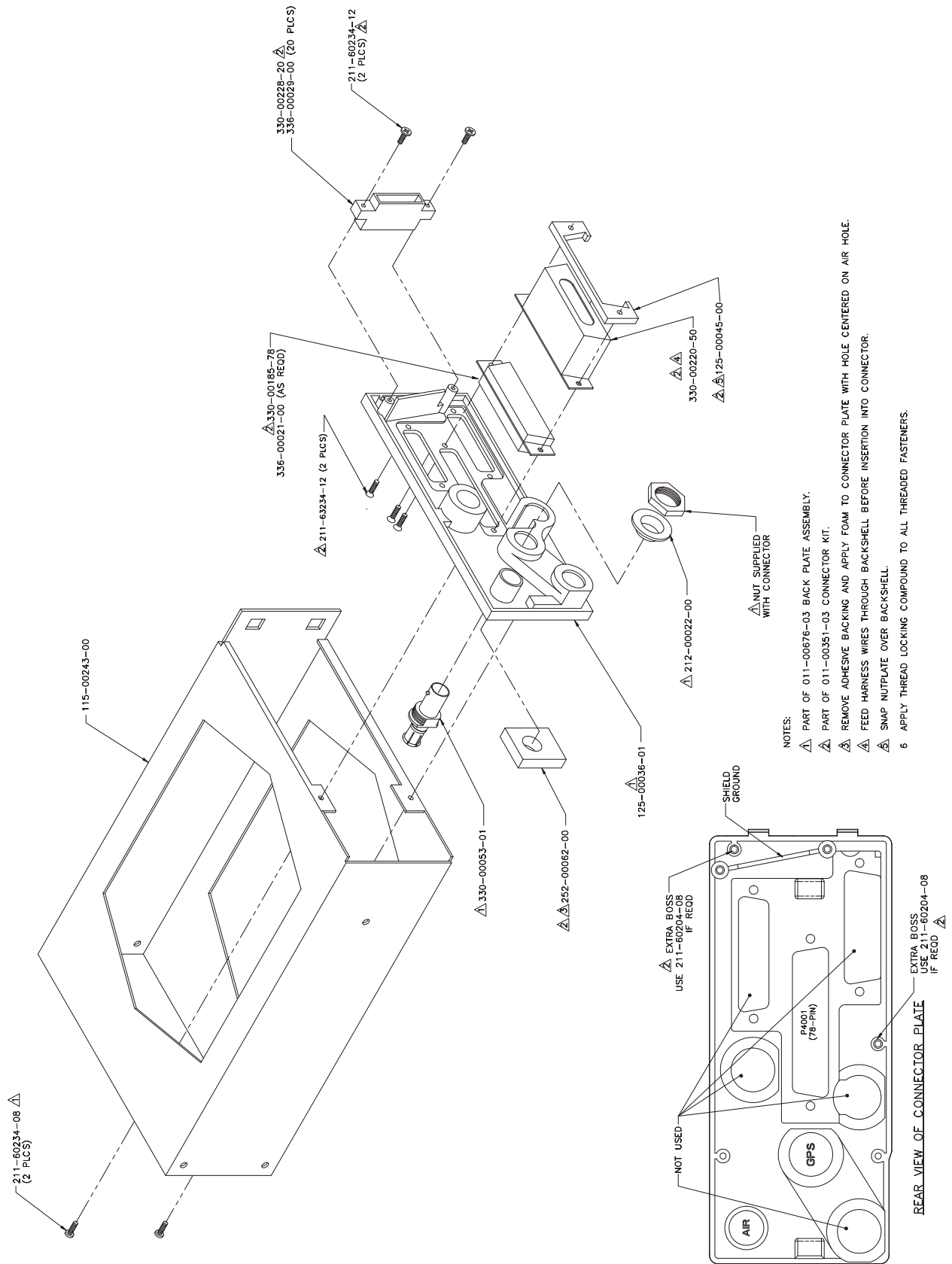
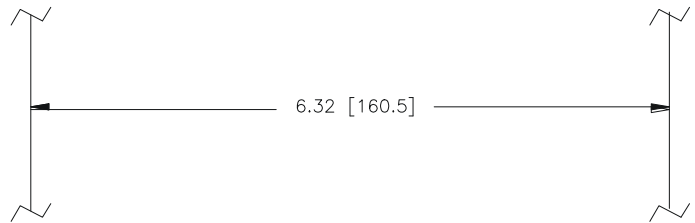

Figure F-4. GPS 400W Mounting Rack Installation

OPTION 1:

STACK CUTOUT (RACK INSTALLED FROM FRONT OF AIRCRAFT PANEL)



OPTION 2:

RADIO CUTOUT (RACK INSTALLED FROM FRONT OF AIRCRAFT PANEL)

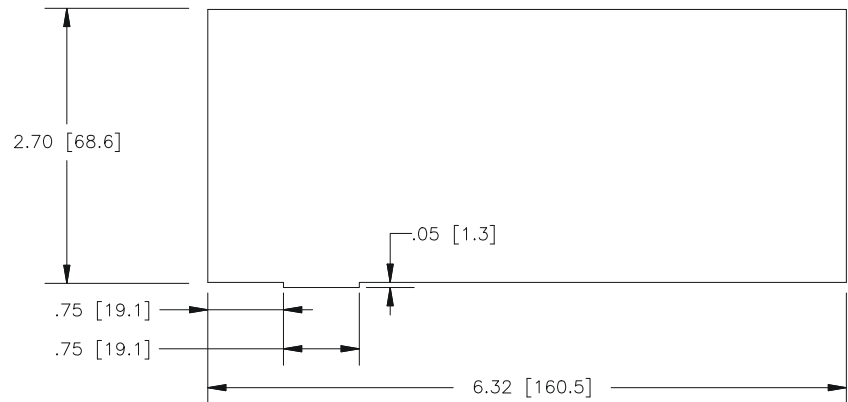

OPTION 3:

RADIO CUTOUT (RACK INSTALLED FROM BACK OF AIRCRAFT PANEL ONLY)
MAXIMUM AIRCRAFT PANEL THICKNESS IS .125 INCH [3.2 mm]

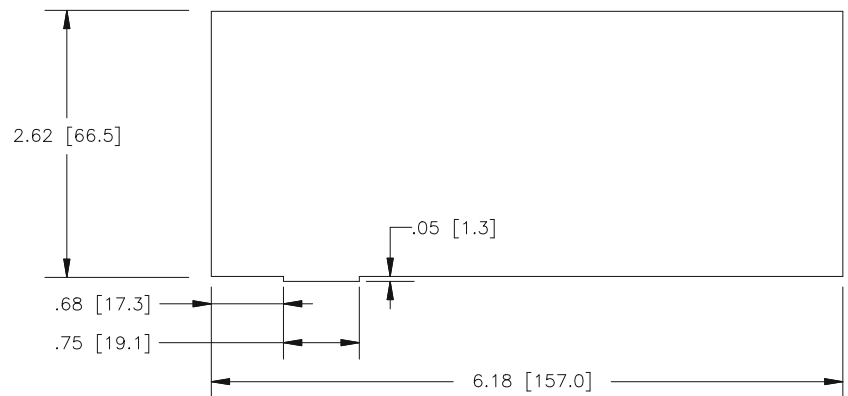

NOTES:

1. DIMENSIONS: INCH [mm].
2. IF THE FRONT LIP OF THE MOUNTING RACK IS BEHIND THE SURFACE OF THE AIRCRAFT PANEL, THE 400 SERIES UNIT CONNECTORS MAY NOT FULLY ENGAGE.

Figure F-5. 400W Series Recommended Panel Cutout Dimensions

This page intentionally left blank

Appendix G APPROVED EQUIPMENT

The following tables list equipment that can be interfaced with the Garmin 400W Series units. This is not a complete listing however; it only represents those units that are approved under 400W/500W Series AML STC SA01933LA, with any exceptions noted by the appropriate table. When installing equipment on the aircraft always refer to the manufacturers' documentation for complete pinout and interconnect information.

G.1 Audio Panels

Audio panels not listed below can still be approved under 400W/500W Series AML STC SA01933LA if **all** of the following conditions are met:

- The installation of the audio panel was previously was previously FAA-approved;
- The VHF COM audio and VHF NAV audio (if applicable) must be verified as described in sections 5.5.4 and 5.5.5.

Manufacturer	Model	Data Format	Notes
Honeywell (Bendix/King)	KMA 24 KMA 24H-70/71 KMA 26 KMA 28		
Garmin	GMA 340 GMA 347		
Garmin AT	SL15 SL15M SL10S SL10MS SL10 SL10M		
PS Engineering	PMA 6000 PMA 7000 Series PMA 8000 Series		

G.2 Air Data Computer

Air Data Computers not listed below can still be approved under 400W/500W Series AML STC SA01933LA if **all** of the following conditions are met:

- The air data computer is TSO approved;
- The installation of the air data computer was previously FAA-approved;
- The interface check for the altitude encoder described in section 5.4.4 must be successfully completed.

Manufacturer	Model	Data Format	Notes
B & D	2600 2601 2800 90004-003	ARINC 429 ARINC 429 ARINC 429 ARINC 429	
Honeywell (Bendix/King)	KDC 281 KDC 481	ARINC 429 ARINC 429	
Insight	TAS 1000	RS-232	

G.3 Altitude Serializer or Fuel/Air Data

Altitude serializers/encoders not listed below can still be approved under 400W/500W Series AML STC SA01933LA if **all** of the following conditions are met:

- The altitude serializer/encoder is TSO approved;
- The installation of the altitude serializer/encoder was previously FAA-approved;
- The interface check for the altitude serializer/encoder described in section 5.4.4 (serial interface) or 5.4.5 (parallel / gray code interface) must be successfully completed.

Manufacturer	Model	Data Format	Notes
ARNAV	FC-10 FT-10		
Electronics International	FP-5L		
Icarus Instruments	3000		
JP Instruments	EDM-700		
Sandia	SAE 5-35		
Shadin	8800T 9000T 9200T F/ADC-200 F/ADC-2000 91204XT(38)D (Miniflo-L) 91053XP (Digiflo-L) 91053XT-D (Digiflo-L) 91802-() (Digidata)	RS-232	
Trans-Cal Industries	IA-RS232-X SSD120	RS-232 RS-232	
ACK Technologies	A-30	RS-232	Mod 8 and above

G.4 Autopilots

Autopilots that will be coupled to GPS *vertical* guidance for GPS approaches **must** be specifically listed in the table below.

Autopilots not listed in Appendix G can still be approved under 400W/500W Series AML STC SA01933LA if **all** of the following conditions are met:

- The installation of the autopilot was previously FAA-approved;
- All interfaces between the 400W Series unit and the autopilot are analog;
- The installation must use existing navigation signals which interface the autopilot to a standard VHF navigation receiver (i.e. CDI/HSI L/R and Up/Dn)
- A successful in-air flight check must be completed prior to returning the aircraft to service.
- The AFMS is properly completed, limiting the GPS to lateral coupling only (LNAV)

If these conditions are met the interface can be approved under AML STC SA01933LA. These autopilots are limited to those operations for which they were previously FAA-approved when interfaced with the other TC'd or STC'd navigation units (e.g. if the previous unit was installed and approved for coupled VOR, ILS, LOC, BC and GPS LNAV approaches, this upgraded installation will also be approved for these operations; however, GPS and RNAV approaches with GPS/WAAS-based vertical guidance (LNAV+V, L/VNAV and LPV modes on the 400W series unit) are not authorized when coupled to the autopilot).

NOTE



Contact Garmin to remove VNAV limitations.

Mfr.	Model	Data Format	Notes
Honeywell (Bendix/King)	KAP 100/140/150 KFC 150/200/250/275/300/325	Analog Deviation, Discrete	If an EFIS is installed, the 400W is connected to the EFIS using ARINC 429 and the EFIS interfaces to the autopilot. The 400W is not connected directly to the autopilot.
	KFC 225	Analog Deviation, Discrete, ARINC 429 GPSS	
Century	I/II/III/IV 21/31/41 2000 Triden	Analog Deviation, Discrete	
	AK 1081	ARINC 429 GPSS	GPSS Roll Steering Converter
S-TEC	System Twenty/Thirty/40/50 55/60-1/60-2/60 PSS/65	Analog Deviation, Discrete	
	System Fifty Five X	Analog Deviation, Discrete, ARINC 429 GPSS	
	ST-901	ARINC 429 GPSS	GPSS Roll Steering Converter
Cessna	300B/400B/800B	Analog Deviation, Discrete	(CA550A/FD computer)
	300 IFCS/400 IFCS/800 IFCS	Analog Deviation, Discrete	400A Nav-o-matic (CA530FD computer)
Bendix	M4C, M4D	Analog Deviation, Discrete	
Collins	APS 65 ()	Analog Deviation, Discrete	

G.5 Encoding Altimeter or Blind Encoder (Gray Code)

Encoding altimeters or blind encoders not listed below can still be approved under 400W/500W Series AML STC SA01933LA if **all** of the following conditions are met:

- The altitude encoding altimeter / encoder is TSO approved;
- The installation of the altitude encoder was previously FAA-approved;
- The interface check for the altitude encoder described in section 5.4.4 (serial interface) or 5.4.5 (parallel / gray code interface) must be successfully completed.

Manufacturer	Model	Data Format	Notes
Honeywell (Bendix/King)	KEA-130A KEA-346	Parallel Gray Code	
Sandia	SAE-35	Parallel Gray Code	
Terra	AT-3000	Parallel Gray Code	
Trans-Cal Industries	IA-RS-232-X SSD120	Parallel Gray Code Parallel Gray Code	

G.6 EFIS Displays

Manufacturer	Model	Data Format	Notes
Garmin	G600 (GDU 620)	ARINC 429 RS-232	400W/500W Series software version 3.10 or later is required.
Honeywell (Bendix/King)	EFS 40/50 (SG 465)	ARINC 429	400W/500W series software version 3.00 or later is required. SG 465 software 1101 or later is required. Vertical guidance is provided for GPS approaches.
Avidyne	EXP5000 P/N 700-00006-()	ARINC 429	PFD software P/N 530-00194-() or later is required.

G.7 EHSI

Manufacturer	Model	Data Format	Notes
Sandel	SN 3308	Analog/ARINC 429	GPS lateral and vertical guidance is provided using the analog interface.
	SN3500	ARINC 429	Vertical guidance is provided for GPS approaches.

G.8 IRU/AHRS

Manufacturer	Model	Data Format	Notes
Honeywell (Bendix/King)	KAU 461	ARINC 429	
Collins	AHC 85E	ARINC 429	
Honeywell (Bendix/King)	Laseref HG 1075 AB HG 1095 AB	ARINC 429 ARINC 429 ARINC 429	
Litef	LTR 81	ARINC 429	
Litton	LTN 90-100 LTN-91 LTN-92	ARINC 429 ARINC 429 ARINC 429	

G.9 NAV Indicator

Manufacturer	Model	Data Format	Notes
Honeywell (Bendix/King)	KI 202A KI 203 KI 204 KI 206 KI 208/A KI 209/A KI 525A KPI 552/B KPI 553/A/B		
Century	NSD 360A NSD 1000		
Collins	331A-6P 331A-9G PN101 (331A-3F/3G)		
Garmin	GI 102/A GI 106/A		
S-TEC	ST 180		
Sperry	RD 444 RD 550A RD 650		
Mid Continent	MD222-402 MD222-406		

G.10 Weather, Traffic and Terrain

Manufacturer	Model	Data Format	Notes
Garmin	GDL 69 GTX 330	RS-232 ARINC 429	High Speed
Honeywell (Bendix/King)	KGP 560 KTA 870 (KTA 810) KMH 880 (KMH 820) KTA 970 (KTA 910) [1] KMH 980 (KMH 920) [1]	RS-232 ARINC 429 ARINC 429 ARINC 429 ARINC 429	High Speed High Speed High Speed High Speed
L3 Communications	SKY497 (SkyWatch) SKY899 (SkyWatch HP) WX-500	ARINC 429 ARINC 429 RS-232	High Speed High Speed
Ryan	9900B/BX	RS-232	

[1] 400W series main software version 3.00 or later is required.

G.11 DME

Manufacturer	Model	Data Format	Notes
ARC	RTA-476A		
Honeywell (Bendix/King)	KN61 KN62/62A KN63/KDI 572/KDI 574 KN64 KN65 KDM 706/KDI 572/KDI 574	Parallel Slip Code Parallel 2x5 or King Serial King Serial King Serial Parallel Slip Code King Serial	
Collins	DME 40 DME 42	Parallel 2x5 Parallel 2x5	
S-TEC	TCR-451	Parallel 2x5	
Narco	DME 890 IDME 891	Parallel 2x5	

G.12 CDI/HSI Source Selection Annunciators

An external CDI/HSI Source Selection Annunciation or external GPS annunciations may be required for some installations – see Section 2.5.1.1 for additional information describing when external annunciation is required. The following indicators and indicator/switches are suitable for external annunciation:

Manufacturer	Part Number	Type	Notes
Staco Switch	992561-1241762200	Indicator	14VDC Indicator
Staco Switch	992561-1241862200	Indicator	28VDC Indicator
Vivisun	95-40-17-B6-AW724	Indicator	28VDC Indicator (can be converted to 14VDC operation by replacing qty 4 28VDC lamps with 14VDC lamps P/N 14-113).
Vivisun	95-45-11-B6-AW724	Indicator/Switch	28VDC Indicator with momentary switch (can be converted to 14VDC operation by replacing qty 4 28VDC lamps with 14VDC lamps P/N 14-113).
Mid-Continent	MD41-1408A MD41-1404A MD41-1418A MD41-1414A MD41-1468A MD41-1478A MD41-1464A MD41-1474A MD41-1470 MD41-1484W MD41-1488W	Indicator/Switch/ GPS Annunciations	Both 14VDC and 28VDC indicators (refer to Mid-Continent documentation for availability of switch functions on each unit)

Vendor Contact Information (provided for convenience only):

- Staco Switch, 1139 Baker Street Costa Mesa, CA 92626
Phone: (877) STACO4U
- Vivisun Aerospace Optics, 3201 Sandy Lane Fort Worth, Texas 76112
Phone: (888) VIVISUN
- Mid-Continent Instrument Co Inc., 9400 E. 34th Street N., Wichita, KS 67226, Phone: (316) 630-0101

G.13 Multifunction Displays

Manufacturer	Model	Data Format	Notes
Garmin	MX20	RS-232	“Avtn no alt” format for MX20 version 5.5 and earlier. “Aviation” format for MX20 version 5.6 and later. (MX20 will not accept GPS altitude even though it is part of “Aviation” format). “MapMX” format for MX20 version 5.6 or later. [1]
	GMX 200	RS-232	“Aviation” format “MapMX” format (preferred) [1]
Avidyne	EX500 P/N 700-00007-()	ARINC 429	MFD software P/N 530-00193-() or later is required
	EX5000 P/N 700-00004-() or P/N 700-00030-()	ARINC 429	MFD software P/N 530-00195-() or later is required

[1] Main software version 3.10 or later.

G.14 Interface Adapters

Manufacturer	Model	Data Format	Notes
Garmin	GAD 42	ARINC 429	

This page intentionally left blank

Appendix H STC APPROVED INSTALLATION DIAGRAMS

H.1 Introduction

The equipment interconnect diagrams defined in this appendix are approved per the 400W/500W Series unit AML STC SA01933LA.

H.2 Drawing List

The following drawings are included in this section:

- ❑ Figure H-1. 400W Series System Interface Diagram
- ❑ Figure H-2. GNS 430W Typical Installation
- ❑ Figure H-3. GNC 420W Typical Installation
- ❑ Figure H-4. GPS 400W Typical Installation
- ❑ Figure H-5. Power, Lighting, and Antenna Interconnect
- ❑ Figure H-6. Gray Code Altimeter Interconnect
- ❑ Figure H-7. Main Indicator Interconnect
- ❑ Figure H-8. KI 209A Main Indicator Interconnect
- ❑ Figure H-9. KI 208A Main Indicator Interconnect
- ❑ Figure H-10. RS-232 Serial Data Interconnect
- ❑ Figure H-11. ARINC 429 EFIS Interconnect
- ❑ Figure H-12. ARINC 429 Sandel EHSI Interconnect (One 400W Series Unit, One Sandel SN3308)
- ❑ Figure H-13. ARINC 429 Sandel EHSI Interconnect (Two GNS 430W, One Sandel SN3308)
- ❑ Figure H-14. ARINC 429 Sandel EHSI Interconnect (Two GNS 430W, Two Sandel SN3308)
- ❑ Figure H-15. ARINC 429/RS-232 Air Data/IRU/AHRS Interconnect
- ❑ Figure H-16. Traffic Advisory System Interconnect
- ❑ Figure H-17. GTX 330 Interconnect
- ❑ Figure H-18. Weather and Terrain Interconnect
- ❑ Figure H-19. Audio Panel Interconnect
- ❑ Figure H-20. VOR/ILS Indicator Interconnect
- ❑ Figure H-21. RMI/OBI Interconnect
- ❑ Figure H-22. King Serial Panel DME Tuning Interconnect
- ❑ Figure H-23. King Serial Remote DME Tuning Interconnect
- ❑ Figure H-24. Parallel 2 of 5 DME Tuning Interconnect
- ❑ Figure H-25. Bendix/King Analog Autopilot Interconnect
- ❑ Figure H-26. Century Autopilot Interconnect
- ❑ Figure H-27. S-TEC Autopilot Interconnect
- ❑ Figure H-28. ARINC 429 Sandel EHSI Interconnect (One 400W, One Sandel SN3500)
- ❑ Figure H-29. External Navigation Source and GPS Annunciators
- ❑ Figure H-30. Parallel Slip Code DME Tuning Interconnect
- ❑ Figure H-31. Cessna Autopilot Interconnect
- ❑ Figure H-32. Bendix Autopilot Interconnect
- ❑ Figure H-33. Switches Interconnect
- ❑ Figure H-34. ARINC 429 Avidyne PFD/MFD Interconnect
- ❑ Figure H-35. Collins Autopilot Interconnect
- ❑ Figure H-36. Garmin GAD 42 Interconnect
- ❑ Figure H-37. Garmin G600 Interconnect

This page intentionally left blank

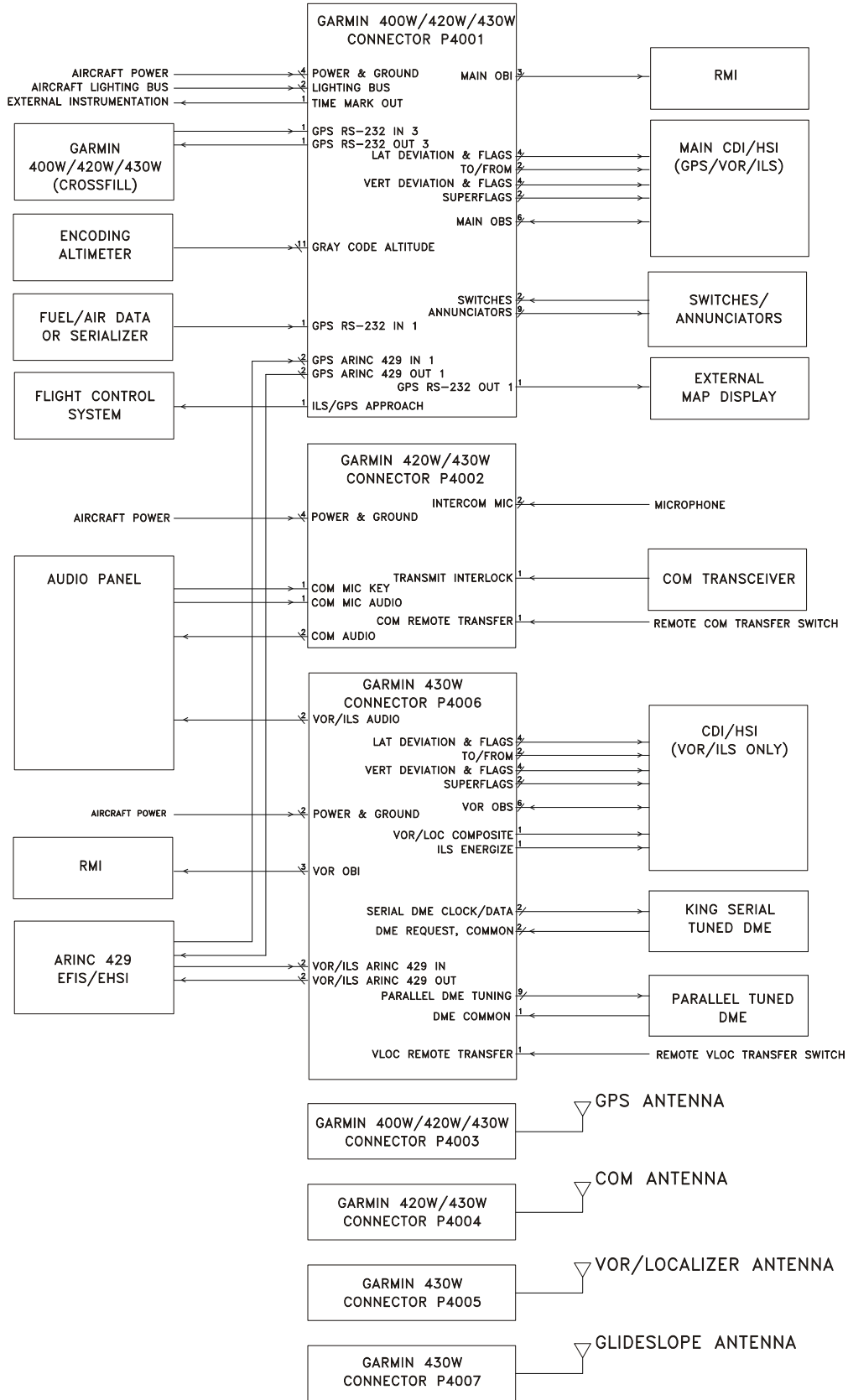

Figure H-1. 400W Series System Interface Diagram

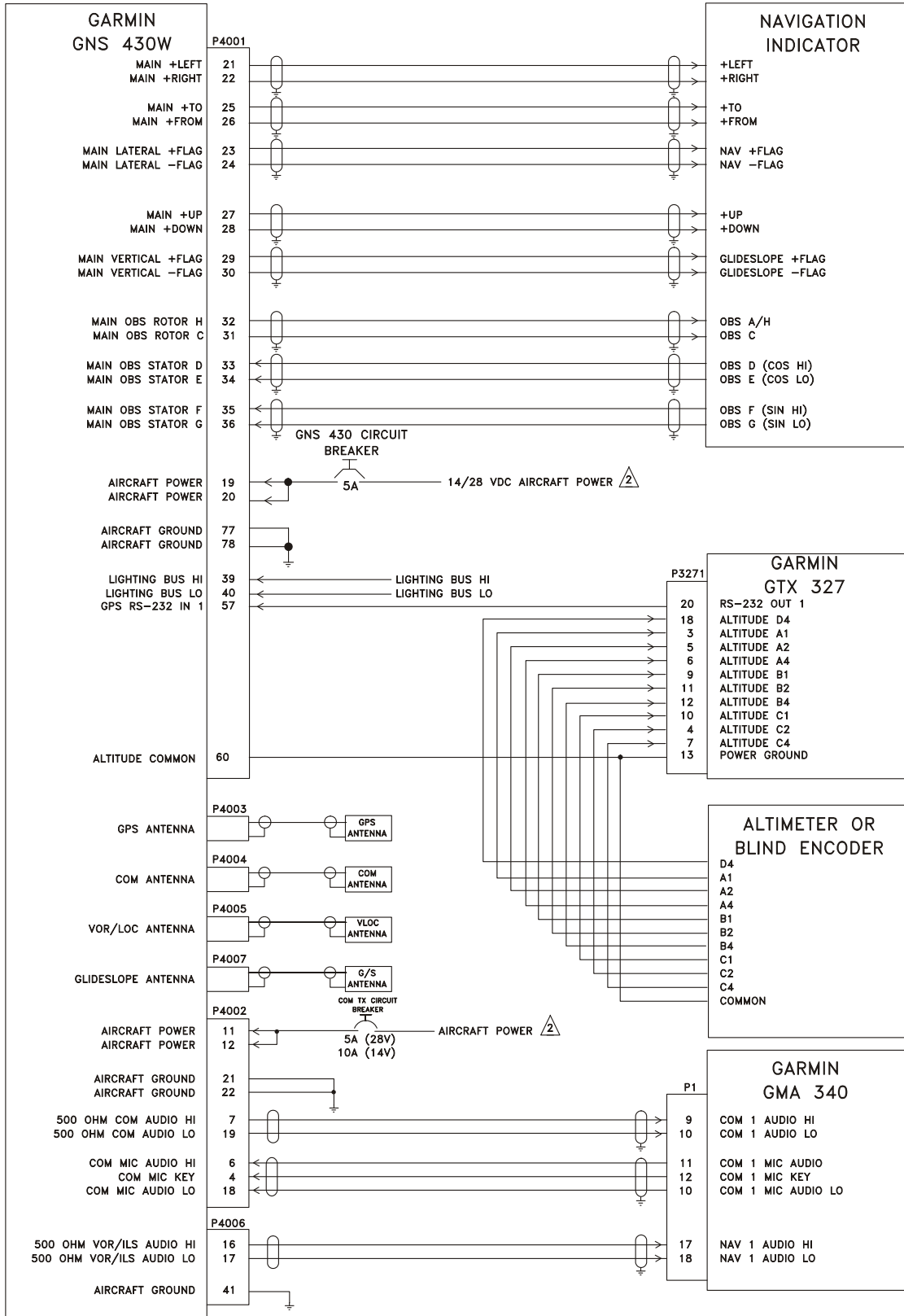

Figure H-2. GNS 430W Typical Installation
Sheet 1 of 2

NOTES:

1. THIS DIAGRAM PROVIDES AN OVERVIEW OF A TYPICAL GNS 430W/(AW) INSTALLATION. REFER TO APPROPRIATE INTERCONNECT DIAGRAMS FOR SPECIFIC EQUIPMENT.

2 AIRCRAFT POWER INPUT TO THE MAIN BOARD (P4001), AND THE GNS 430W VOR/ILS BOARD (P4006) MAY BE 11-33 VDC. THE AIRCRAFT POWER INPUT ON THE COM BOARD (P4002) IS DEPENDENT ON THE PART NUMBER OF THE UNIT:

GNC 420W P/N 011-01058-00, -10, -40, -50 GNS 430W P/N 011-01060-00, -10, -40, -50	14/28 VOLTS DC
GNC 420AW P/N 011-01059-00, -10, -40, -50 GNS 430AW P/N 011-01061-00, -10, -40, -50	28 VOLTS DC
GNC 420W P/N 011-01058-45 GNS 430W P/N 011-01060-45	28 VOLTS DC

**Figure H-2. GNS 430W Typical Installation
Sheet 2 of 2**

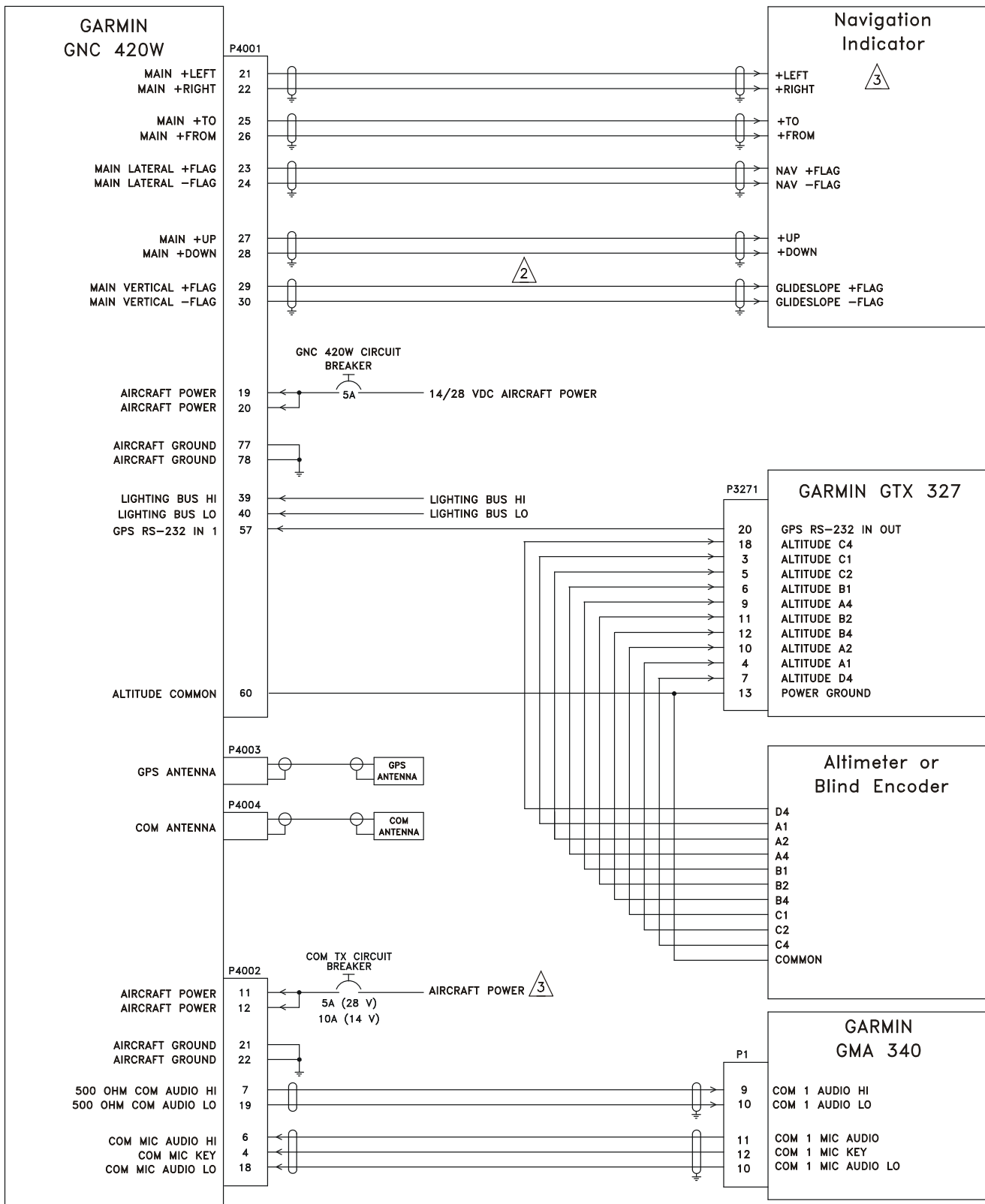

Figure H-3. GNC 420W Typical Installation
Sheet 1 of 2

NOTES:

1. THIS DIAGRAM PROVIDES AN OVERVIEW OF A TYPICAL GNC 420W/(AW) INSTALLATION. REFER TO APPROPRIATE INTERCONNECT DIAGRAMS FOR SPECIFIC EQUIPMENT.
2. IF OBS CONNECTIONS ARE NOT MADE TO THE GNC 420W, THEN ALL OBS COURSE SELECTIONS WILL NEED TO BE MADE USING THE GNC 420W KNOBS. IF AN OBS INTERFACE IS DESIRED, REFER TO THE APPROPRIATE MAIN INDICATOR INTERCONNECT DRAWING.
3. AIRCRAFT POWER INPUT TO THE MAIN BOARD (P4001) MAY BE 11-33 VDC. THE AIRCRAFT POWER INPUT ON THE COM BOARD (P4002) IS DEPENDENT ON THE PART NUMBER OF THE UNIT.

GNC 420W P/N 011-01058-00, -10, -40, -50 GNS 430W P/N 011-01060-00, -10, -40, -50	14/28 VOLTS DC
GNC 420AW P/N 011-01059-00, -10, -40, -50 GNS 430AW P/N 011-01061-00, -10, -40, -50	28 VOLTS DC
GNC 420W P/N 011-01058-45 GNS 430W P/N 011-01060-45	28 VOLTS DC

Figure H-3. GNC 420W Typical Installation
Sheet 2 of 2

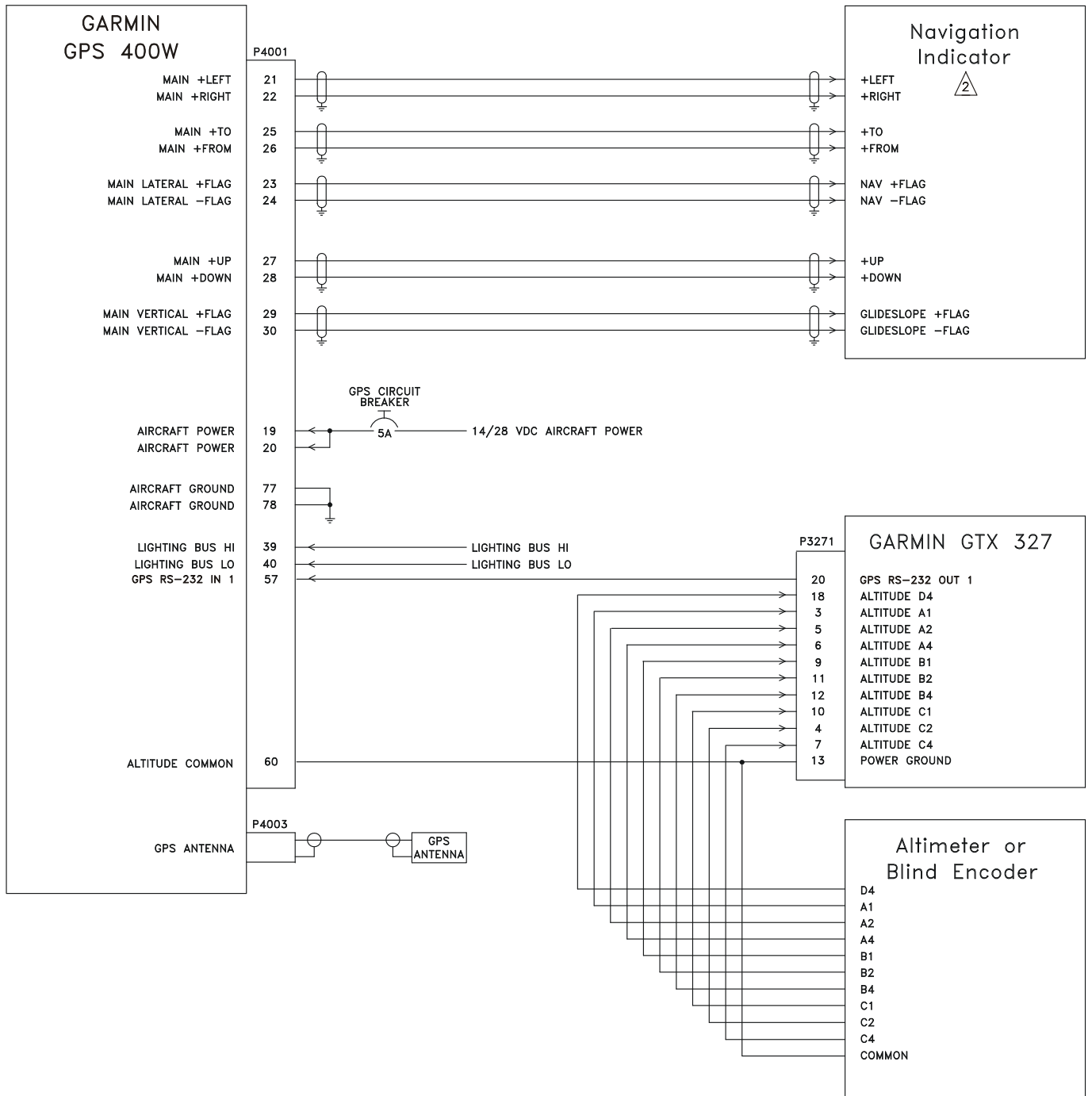

Figure H-4. GPS 400W Typical Installation
Sheet 1 of 2

NOTES:

1. THIS DIAGRAM PROVIDES AN OVERVIEW OF A TYPICAL GPS 400W INSTALLATION. REFER TO APPROPRIATE INTERCONNECT DIAGRAMS FOR SPECIFIC EQUIPMENT.

⚠ IF OBS CONNECTIONS ARE NOT MADE TO THE GPS 400W, THEN ALL OBS COURSE SELECTIONS WILL NEED TO BE MADE USING THE GPS 400W KNOBS. IF AN OBS INTERFACE IS DESIRED, REFER TO THE APPROPRIATE MAIN INDICATOR INTERCONNECT DRAWING.

Figure H-4. GPS 400W Typical Installation
Sheet 2 of 2

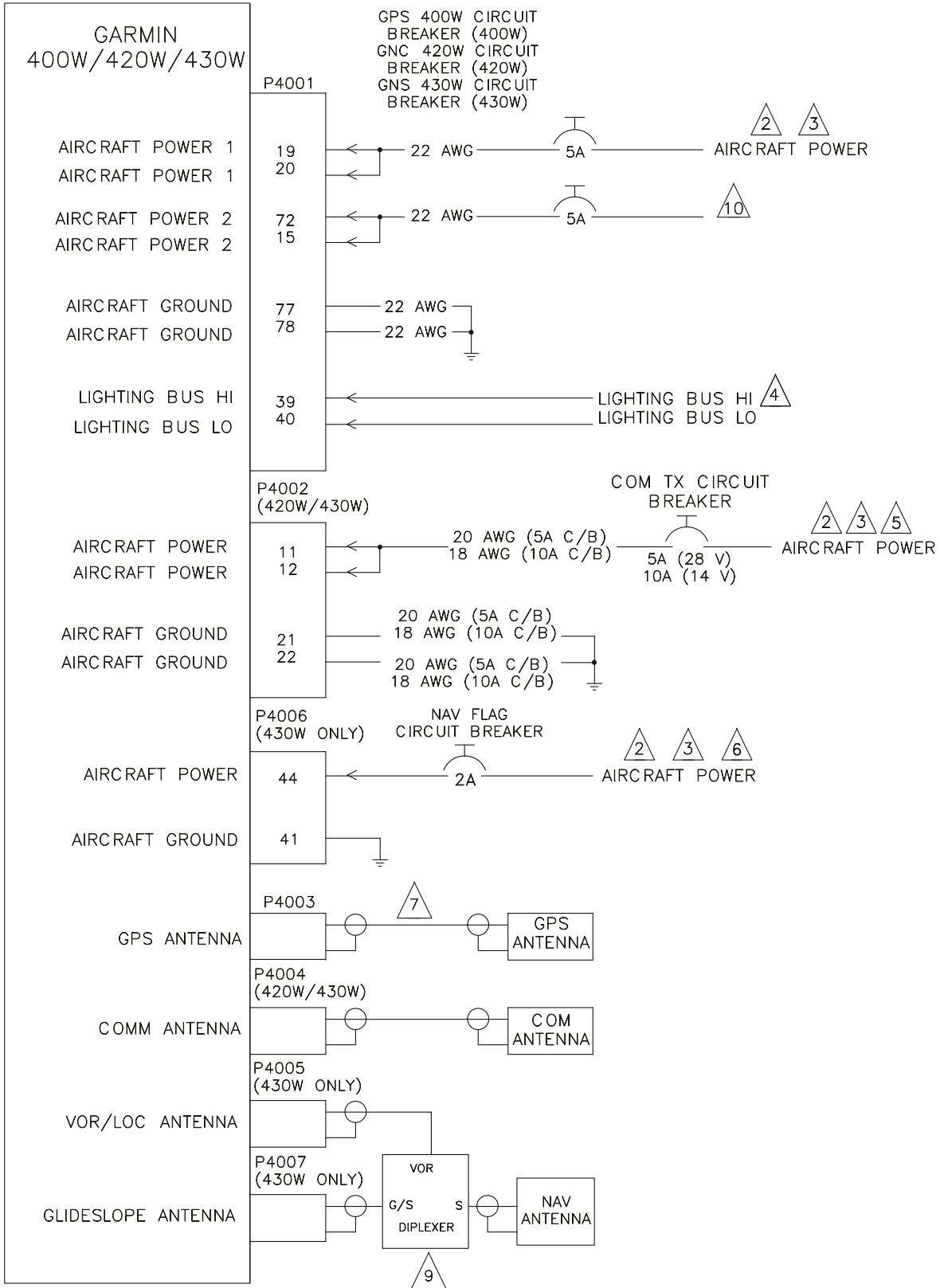

Figure H-5. Power, Lighting, and Antenna Interconnect
 Sheet 1 of 3

DUAL GNS 430W ANTENNA CONNECTIONS

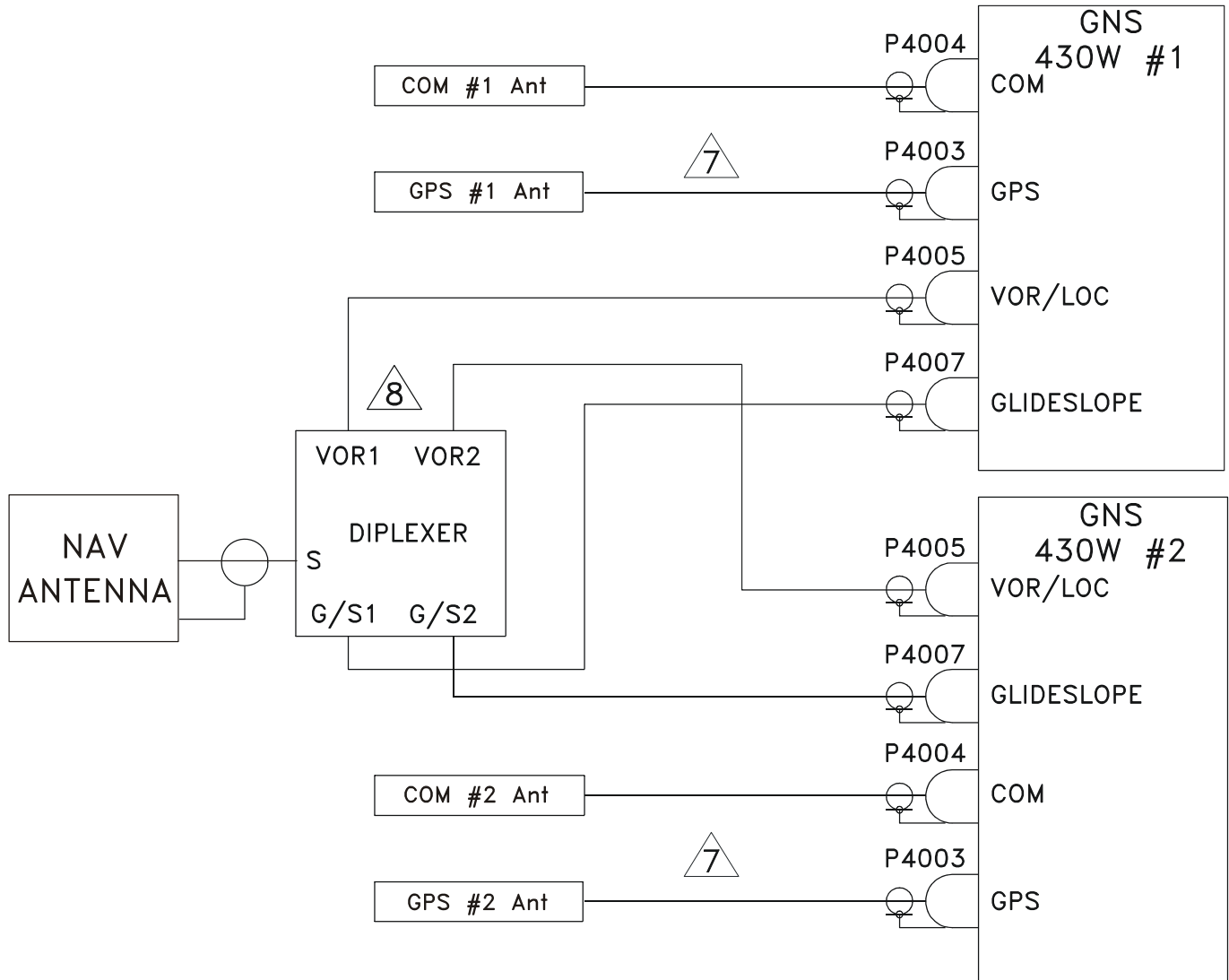

Figure H-5. Power, Lighting, and Antenna Interconnect
Sheet 2 of 3

NOTES:

1. ALL WIRES 24 AWG OR LARGER UNLESS OTHERWISE NOTED

2. IF THE AIRCRAFT HAS MULTIPLE POWER BUSES, IT IS RECOMMENDED THAT ALL GNS 430W POWER INPUTS BE CONNECTED TO THE SAME POWER BUS.

THE FOLLOWING TABLE SHOWS WHAT GNS 430W FUNCTIONS DEPEND ON WHICH POWER INPUTS:

P4001	ALL GNS 430W FUNCTIONS DEPEND ON THIS POWER INPUT
P4002	COM TRANSMITTER
P4006	NAV SUPERFLAG, GLIDESLOPE SUPERFLAG

3. AIRCRAFT POWER INPUT TO THE MAIN BOARD (P4001), AND THE GNS 430W VOR/ILS BOARD (P4006) MAY BE 11-33 VDC. THE AIRCRAFT POWER INPUT ON THE COM BOARD (P4002) IS DEPENDENT ON THE PART NUMBER OF THE UNIT:

GNC 420W P/N 011-01058-00, -10, -40, -50 GNS 430W P/N 011-01060-00, -10, -40, -50	14/28 VOLTS DC
GNC 420AW P/N 011-01059-00, -10, -40, -50 GNS 430AW P/N 011-01061-00, -10, -40, -50	28 VOLTS DC
GNC 420W P/N 011-01058-45 GNS 430W P/N 011-01060-45	28 VOLTS DC

4. THE 400W SERIES UNIT SHOULD BE CONFIGURED FOR THE CORRECT LIGHTING BUS VOLTAGE (28 VDC, 14 VDC, 5 VDC OR 5 VAC) POST-INSTALLATION. NO DAMAGE WILL OCCUR IF THE UNIT IS CONFIGURED INCORRECTLY. IN ADDITION, LIGHTING CAN BE SET TO AUTOMATICALLY COMPENSATE FOR AMBIENT LIGHTING CONDITIONS USING ITS PHOTOCELL. A MANUAL LIGHTING CONTROL OPTION IS ALSO AVAILABLE. REFER TO THE POST-INSTALLATION CONFIGURATION PROCEDURE.

5. MAXIMUM ALLOWABLE WIRE GAUGE INTO P4002 PINS IS #22 AWG. FOR #18 AWG WIRE USE SPECIAL #18 AWG TERMINATION SOCKET CONTACT (336-00023-00) SUPPLIED WITH CONNECTOR KIT. PROTECT EXPOSED CONDUCTOR ON SPECIAL LARGE TERMINATION CONTACTS WITH 3/8 INCH (1 cm) LENGTH OF SHRINK TUBING SUPPLIED WITH CONNECTOR KIT.

6. THE AIRCRAFT POWER INPUT P4006-44 PROVIDES POWER FOR THE VOR/LOC SUPERFLAG (P4006-15) AND GLIDESLOPE SUPERFLAG (P4006-38) OUTPUTS. NO POWER CONNECTION IS REQUIRED ON P4006-44 IF THESE FLAG OUTPUTS ARE NOT USED.

7. THE GPS ANTENNA COAXIAL CABLE MUST BE DOUBLE OR TRIPLE SHIELDED AND THE LOSS (INCLUDING CONNECTORS) MUST BE GREATER THAN 3dB AND LESS THAN 7 dB.

8. COMANT C11125 DIPLEXER OR EQUIVALENT SHOULD BE USED.

9. COMANT C1507 DIPLEXER OR EQUIVALENT SHOULD BE USED.

10. ACFT PWR 1 IS INTERNALLY DIODE ISOLATED FROM ACFT PWR 2. ONLY ONE POWER INPUT IS REQUIRED FOR NORMAL OPERATION.

Figure H-5. Power, Lighting, and Antenna Interconnect
Sheet 3 of 3

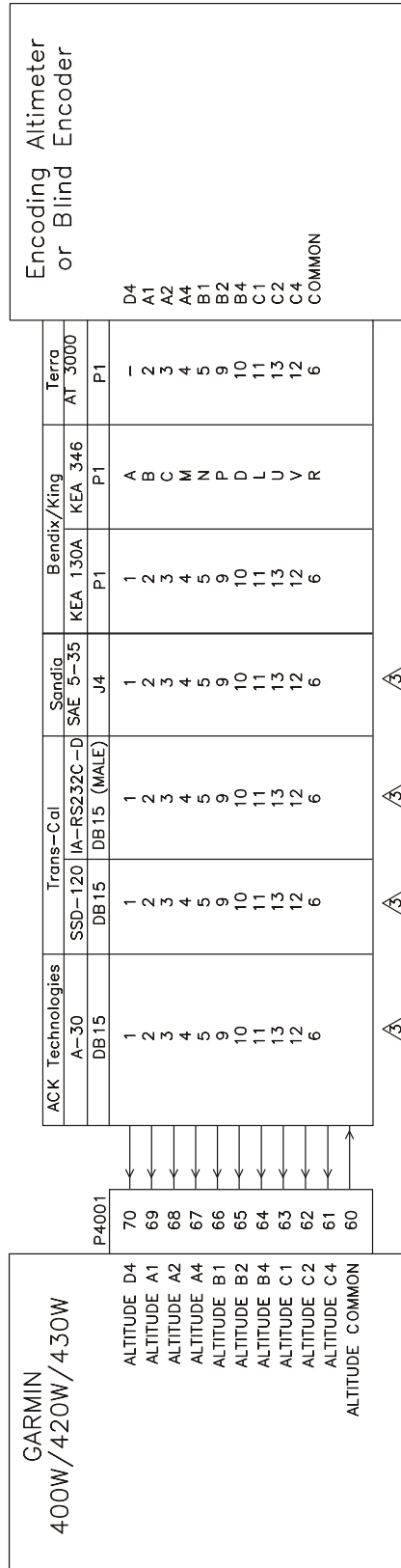

1. ALL WIRES 24 AWG OR LARGER UNLESS OTHERWISE NOTED.
 2. REFER TO MANUFACTURER S DOCUMENTATION FOR COMPLETE PINOUT AND INTERCONNECT INFORMATION. PINOUTS OF OTHER UNITS SHOWN FOR REFERENCE ONLY.
- ⚠ THIS ENCODER MAY ALSO BE CONNECTED VIA RS-232

Figure H-6. Gray Code Altimeter Interconnect

GARMIN 400W/420W/430W	GARMIN		S-TEC		BENDIX KING		CENTURY		COLLINS		SPERRY		MID CONTINENT		Navigation Indicator		
	102A/GI		180		KI 525A		NSD360A NSD1000		331A-96PN-101		RD 444		RD 550A			RD 650	
	P1	P2	P1	P2	P1	P2	P1	P2	P1	P2	P1	P2	P1	P2		P1	P2
21	11	11	27	n	v	i	17	CDT132	4	j	-	F	-	4	22	+LEFT	
22	12	12	43	j	b	h	18		3	i	-	E	-	3	23	+RIGHT	
25	9	9	26	e	Z	j	33		1	n	-	A	-	1	16	+TO	
26	10	10	42	S	T	k	34		2	d	-	B	-	2	17	+FROM	
23	7	7	37	N	K	f	31		-	k	-	-	-	-	20	NAV +FLAG	
24	8	8	38	F	F	g	32		-	m	-	-	-	-	21	NAV -FLAG	
17	-	-	-	-	-	-	-		37	-	-	P	-	39	NAV SUPERFLAG		
27	-	-	44	k	-	E	27		5	r	-	C	-	5	+UP		
28	-	-	28	m	B	HH	28		6	q	-	D	-	6	+DOWN		
29	-	-	36	H	J	FF	30		-	s	-	-	-	-	18	G/S +FLAG	
30	-	-	35	J	W	GG	29		-	t	-	-	-	-	19	G/S -FLAG	
18	-	-	-	-	-	-	-		7	-	-	U	-	38	G/S SUPERFLAG		
32	1	1	22	Z	X	W	15		1	o	-	DD	-	6	OBS A/H		
31	2	2	24	Z	a	N,V	16		3	a	-	FF	-	8	OBS C		
33	3	3	25	L	V	Z	24		4	d	-	Z	-	9	OBS D (COS HI)		
34	5	5	39	P	Y	A	23		5	e	-	AA	-	10	OBS E (COS LO)		
35	4	4	40	T	b	Y	26		6	f	-	BB	-	11	OBS F (SIN HI)		
36	6	6	41	W	e	X	25		7	g	-	CC	-	12	OBS G (SIN LO)		
GPS ANNUNCIATOR	-	N/C	-	-	-	-	-		-	-	-	-	-	-	15	GPS ANNUNCIATOR	
VLOC ANNUNCIATOR	-	N/C	-	-	-	-	-		-	-	-	-	-	-	8	VLOC ANNUNCIATOR	
ILS/GPS APPROACH	-	-	-	-	-	-	-		-	-	-	a	-	-	47	ILS ENERGIZE	

Figure H-7. Main Indicator Interconnect

1. ALL WIRES 24 AWG OR LARGER UNLESS OTHERWISE NOTED
2. AT GNS 400W SERIES UNIT, TERMINATE SHIELD GROUNDS TO THE CONNECTOR BACKSHELL OR USE CARD-EDGE CONNECTOR TO TERMINATE SHIELD GROUNDS TO BACK PLATE – THE SHIELD LEADS MUST BE LESS THAN 3.0 INCHES. CONNECT OTHER SHIELD GROUNDS TO AIRCRAFT CHASSIS WITH AS SHORT A CONDUCTOR AS PRACTICAL.
3. LOWER CASE PIN DESIGNATORS ARE SHOWN AS UNDERLINED UPPER CASE LETTERS.
4. REFER TO MANUFACTURER'S DOCUMENTATION FOR COMPLETE PINOUT AND INTERCONNECT INFORMATION. PINOUTS OF OTHER UNITS SHOWN FOR REFERENCE ONLY.

⚠ P4001-2 (GPS ANNUNCIATOR) AND P4001-1 (VLOC ANNUNCIATOR) DO NOT APPLY TO GPS 400W OR GNC 420W.

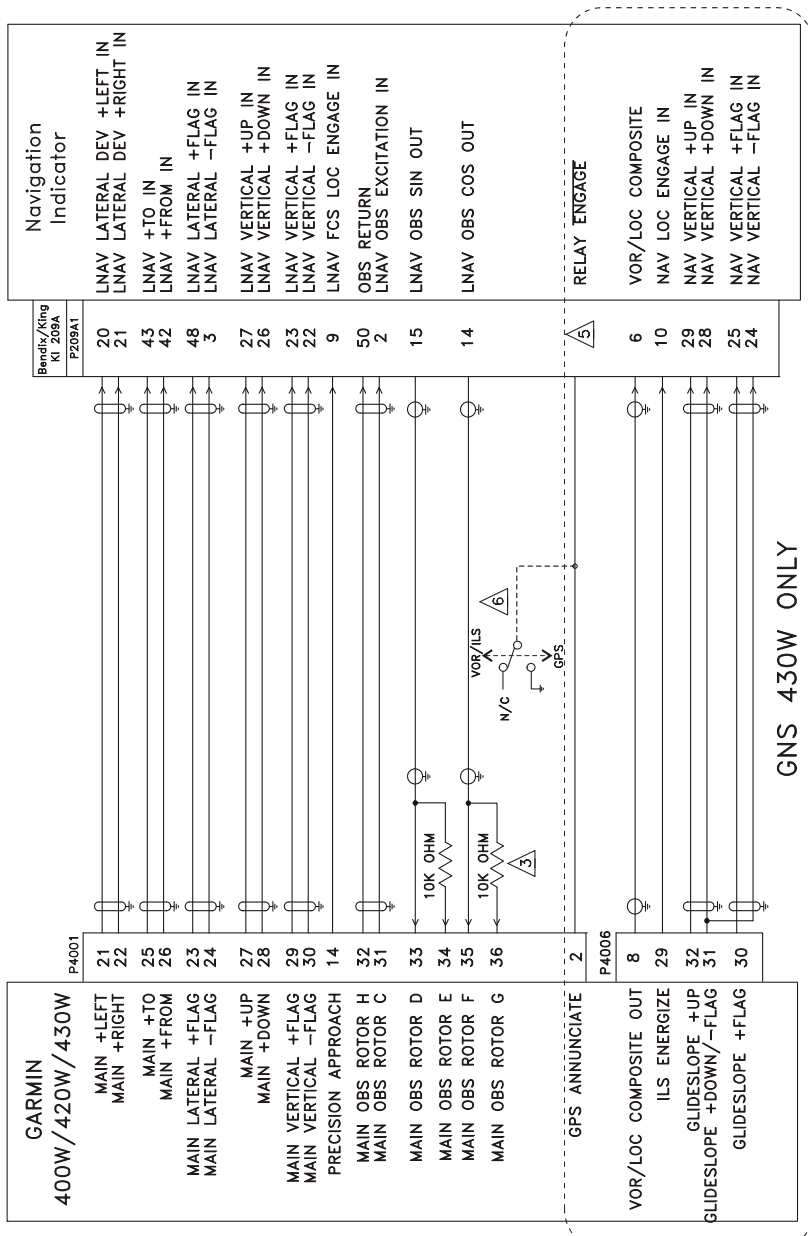

NOTES:

1. ALL WIRES 24 AWG OR LARGER UNLESS OTHERWISE NOTED
2. AT 400W SERIES UNIT, TERMINATE SHIELD GROUNDS TO THE CONNECTOR BACKSHELL OR USE CARD-EDGE CONNECTOR TO TERMINATE SHIELD GROUNDS TO BACK PLATE – THE SHIELD LEADS MUST BE LESS THAN 3.0 INCHES. CONNECT OTHER SHIELD GROUNDS TO AIRCRAFT CHASSIS WITH AS SHORT A CONDUCTOR AS PRACTICAL.
3. TO CONNECT THE GNS 430W TO A KI 209A INDICATOR, ADD TWO 10 KOHM, 1/4 WATT RESISTORS. ONE BETWEEN P4001 PINS 33 AND 34, AND ONE BETWEEN P4001 PINS 35 AND 36.
4. REFER TO MANUFACTURER'S DOCUMENTATION FOR COMPLETE PINOUT AND INTERCONNECT INFORMATION. PINOUTS OF OTHER UNITS SHOWN FOR REFERENCE ONLY.
5. PROPER CONNECTION OF THE RELAY ENGAGE INPUT OF THE KI 209A IS DEPENDENT ON ITS POWER SUPPLY VOLTAGE. REFER TO KI 209A DOCUMENTATION FOR PROPER CONNECTION.
6. IF THE GPS 400W OR GNC 420W IS INSTALLED, AN EXTERNAL SOURCE SELECTION SWITCH MUST BE USED IN LIEU OF THE GPS ANNUNCIATE OUTPUT.

Figure H-8. KI 209A Main Indicator Interconnect

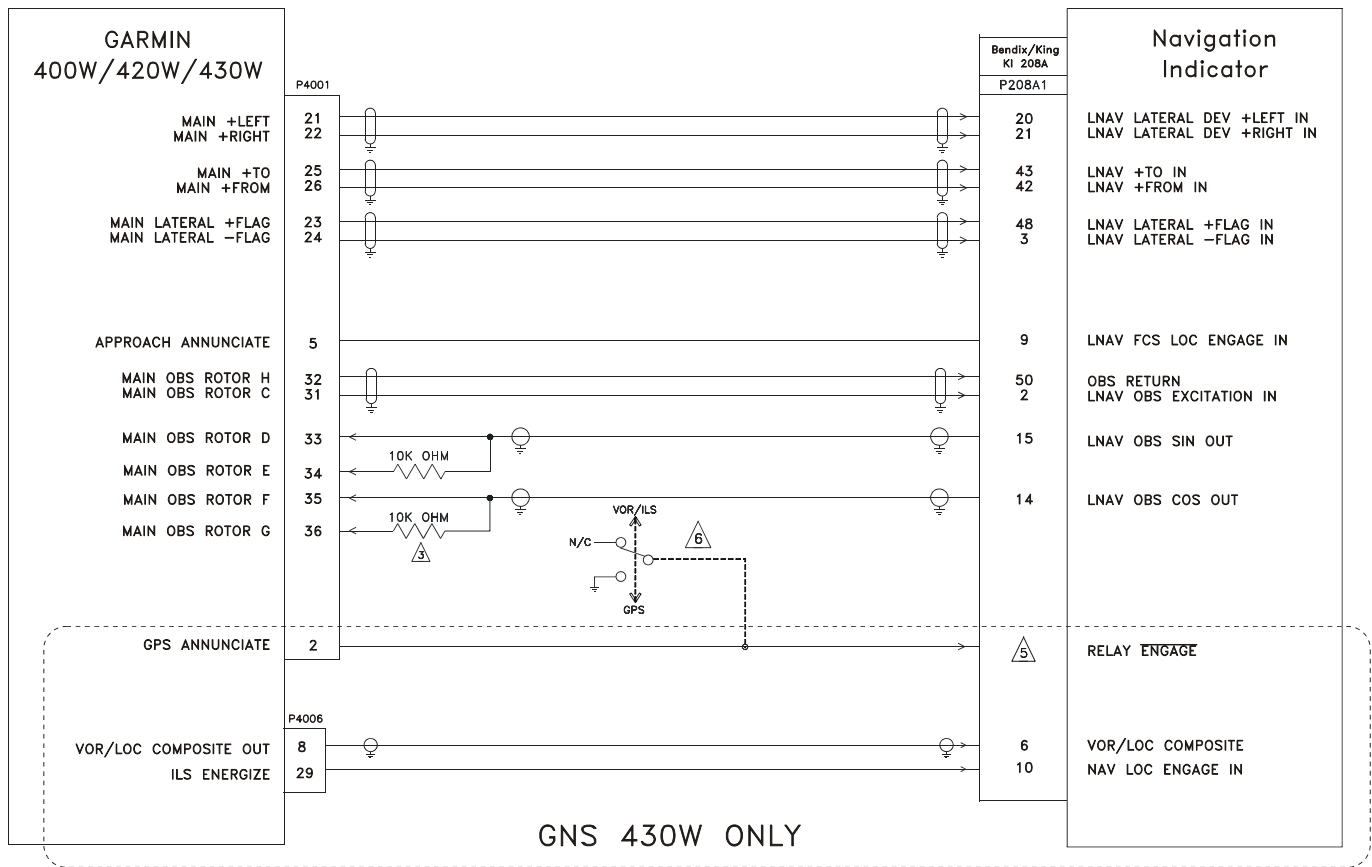

Figure H-9. KI 208A Main Indicator Interconnect

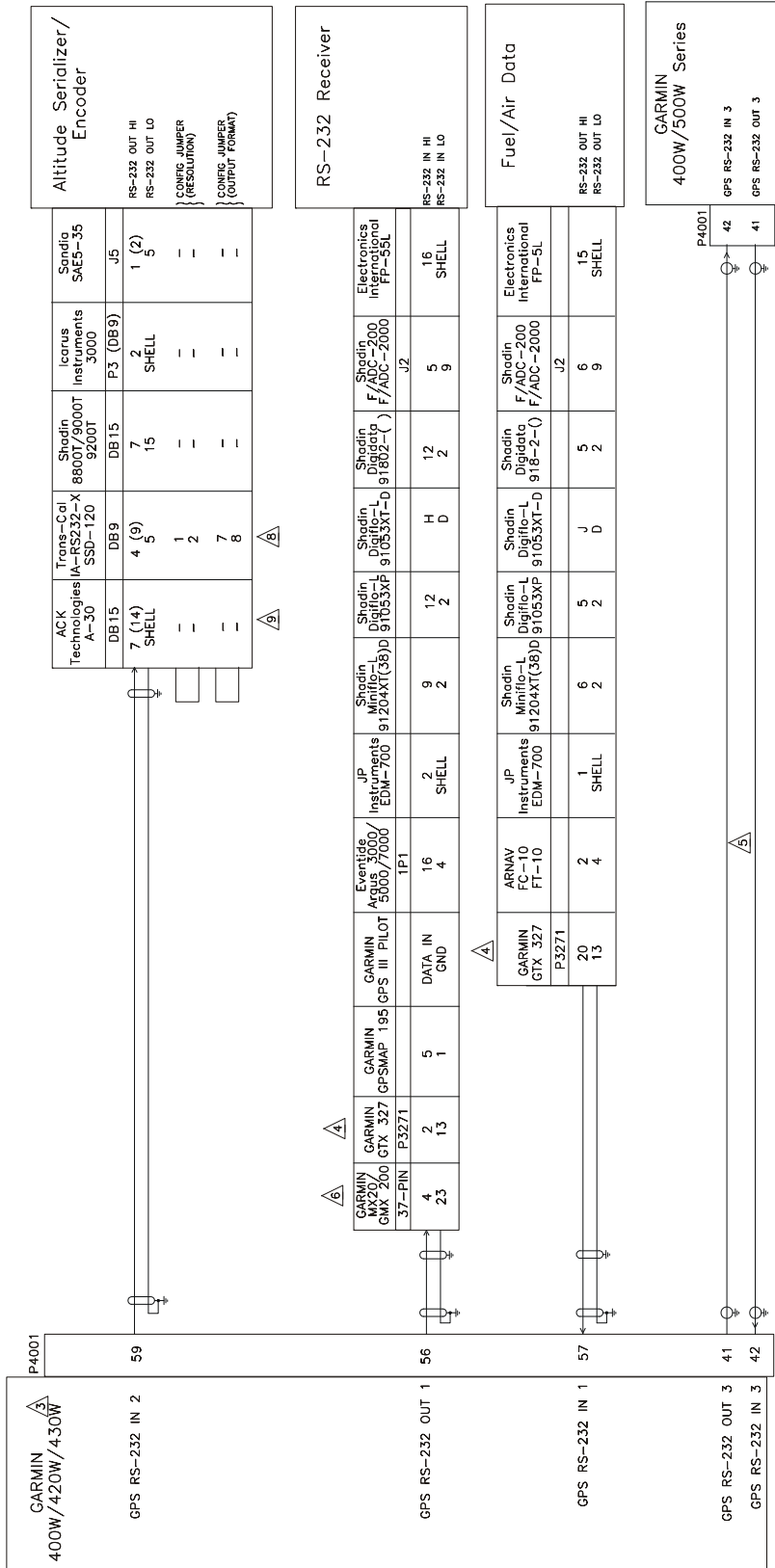

Figure H-10. RS-232 Serial Data Interconnect
Sheet 1 of 2

- NOTES:
1. ALL WIRES 24 AWG OR LARGER UNLESS OTHERWISE NOTED.
 2. AT GNS 400W SERIES UNIT, TERMINATE SHIELD GROUNDS TO THE CONNECTOR BACKSHELL OR USE CARD-EDGE CONNECTOR TO TERMINATE SHIELD GROUNDS TO BACK PLATE – THE SHIELD LEADS MUST BE LESS THAN 3.0 INCHES. CONNECT OTHER SHIELD GROUNDS TO AIRCRAFT CHASSIS WITH AS SHORT A CONDUCTOR AS PRACTICAL.
 3. REFER TO SECTION 5.3.2 FOR RS-232 CHANNEL SETTINGS. RS-232 PORTS 1 TO 3 ARE SHOWN. ANY AVAILABLE RS-232 PORT MAY BE USED.
 4. REFER TO THE GTX 327 TRANSPONDER INSTALLATION MANUAL, 190-00187-02, FOR COMPLETE INFORMATION.
 5. IF TWO OR MORE 400W/500W SERIES UNITS ARE INSTALLED, THE RS-232 LINES ON P4001-41 AND P4001-42 MAY BE CROSS-CONNECTED TO CROSSFILL FLIGHT PLANS AND USER WAYPOINTS. TO CROSSFILL FLIGHT PLANS, IT REQUIRED THAT BOTH 400W/500W SERIES UNITS HAVE IDENTICAL DATABASE CYCLE DATES AND MAY BE REQUIRED THAT THEY HAVE IDENTICAL VERSIONS OF MAIN SOFTWARE.
 6. MAPMX (MAIN SOFTWARE VERSION 3.10 AND LATER) IS THE PREFERRED COMMUNICATION PROTOCOL FOR THE MX20/GMX200. OTHER INPUT PORTS ON MX20/GMX 200 MAY BE USED INSTEAD OF THE PORT SHOWN. REFER TO APPROPRIATE INSTALLATION MANUAL FOR ADDITIONAL DETAILS.
 7. REFER TO MANUFACTURER S DOCUMENTATION FOR COMPLETE PINOUT AND INTERCONNECT INFORMATION. PINOUTS OF OTHER UNITS SHOWN FOR REFERENCE ONLY.
 8. IF USING THE SERIAL PORT SOFTWARE METHOD TO CONFIGURE THE OUTPUT OF THE ENCODER, ENSURE THAT THE "TRIMBLE/GARMIN 9600 BPS" FORMAT IS SELECTED.
 9. MOD LEVEL 8 (OR HIGHER) IS REQUIRED TO SUPPORT RS-232 INTERFACE. ENSURE THAT JUMPERS ARE SET FOR "TRIMBLE/GARMIN 9600 BPS" AND "10 FOOT RESOLUTION".

**Figure H-10. RS-232 Serial Data Interconnect
Sheet 2 of 2**

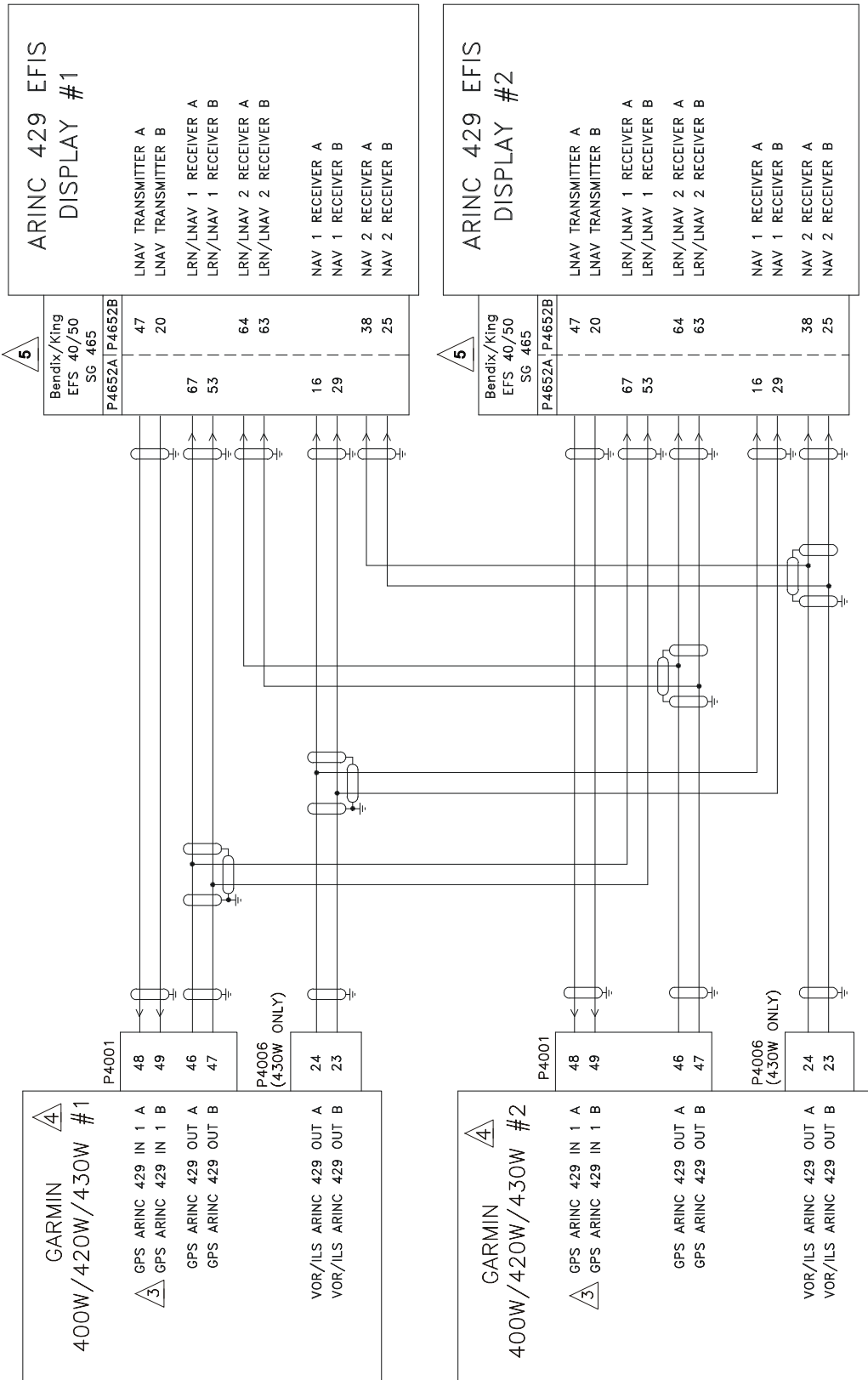

Figure H-11. ARINC 429 EFIS Interconnect
Sheet 1 of 2

NOTES:

1. ALL WIRES 24 AWG OR LARGER UNLESS OTHERWISE NOTED
2. AT GNS 400W SERIES UNIT, TERMINATE SHIELD GROUNDS TO THE CONNECTOR BACKSHELL OR USE CARD-EDGE CONNECTOR TO TERMINATE SHIELD GROUNDS TO BACK PLATE – THE SHIELD LEADS MUST BE LESS THAN 3.0 INCHES. CONNECT OTHER SHIELD GROUNDS TO AIRCRAFT CHASSIS WITH AS SHORT A CONDUCTOR AS PRACTICAL.
- 3 IF THE GPS ARINC 429 IN 1 PORT (P4001-48 AND -49) IS ALREADY USED FOR ANOTHER PURPOSE, THE GPS ARINC 429 IN 2 PORT (P4001-50 AND -51) MAY BE CONNECTED INSTEAD.

- 4 GNS 430W #1 SETUP ITEMS:
MAIN ARINC 429 CONFIG:

IN 1: LOW, EFIS/AIRDATA*
OUT: LOW, GAMA 429 BENDIX KING
SDI: LNAV 1
VNAV: ENABLE LABELS

SPEED RX: LOW TX: LOW
SDI: VOR/ILS 1

VOR/LOC/GS ARINC 429 CONFIG:

- GNS 430W #2 SETUP ITEMS:
MAIN ARINC 429 CONFIG:

IN 1: LOW, EFIS/AIRDATA*
OUT: LOW, GAMA 429 BENDIX KING
SDI: LNAV 2
VNAV: ENABLE LABELS

SPEED RX: LOW TX: LOW
SDI: VOR/ILS 2

VOR/LOC/GS ARINC 429 CONFIG:

*FOR EFS 40/50 SOFTWARE VERSION 1201 OR LATER. FOR EARLIER SOFTWARE VERSIONS, USE "EFIS" SETTING.

- 5 SG 465 SOFTWARE 1101 (OR LATER) IS REQUIRED FOR PROPER OPERATION WITH THE GNS 400W SERIES UNIT.

FMS #1/#2 CONFIGURATION: 5: KLN 90-GPS*
FMS VNAV CONFIGURATION: 2: FEET OR ANGLE
VARIABLE LNAV CONFIGURATION: LNAV 1/2: VAR
*KLN 90-GPS SETTING **MUST** BE USED IN ORDER FOR VERTICAL GPS DEVIATION TO BE DISPLAYED CORRECTLY.

6. REFER TO MANUFACTURER'S DOCUMENTATION FOR COMPLETE PINOUT AND INTERCONNECT INFORMATION. PINOUTS OF OTHER UNITS SHOWN FOR REFERENCE ONLY.
7. A 500W SERIES UNIT MAY BE USED IN PLACE OF EITHER #1 OR #2 400W SERIES UNIT. SEE THE 500W INSTALLATION MANUAL.

H-11. ARINC 429 EFIS Interconnect
Sheet 2 of 2

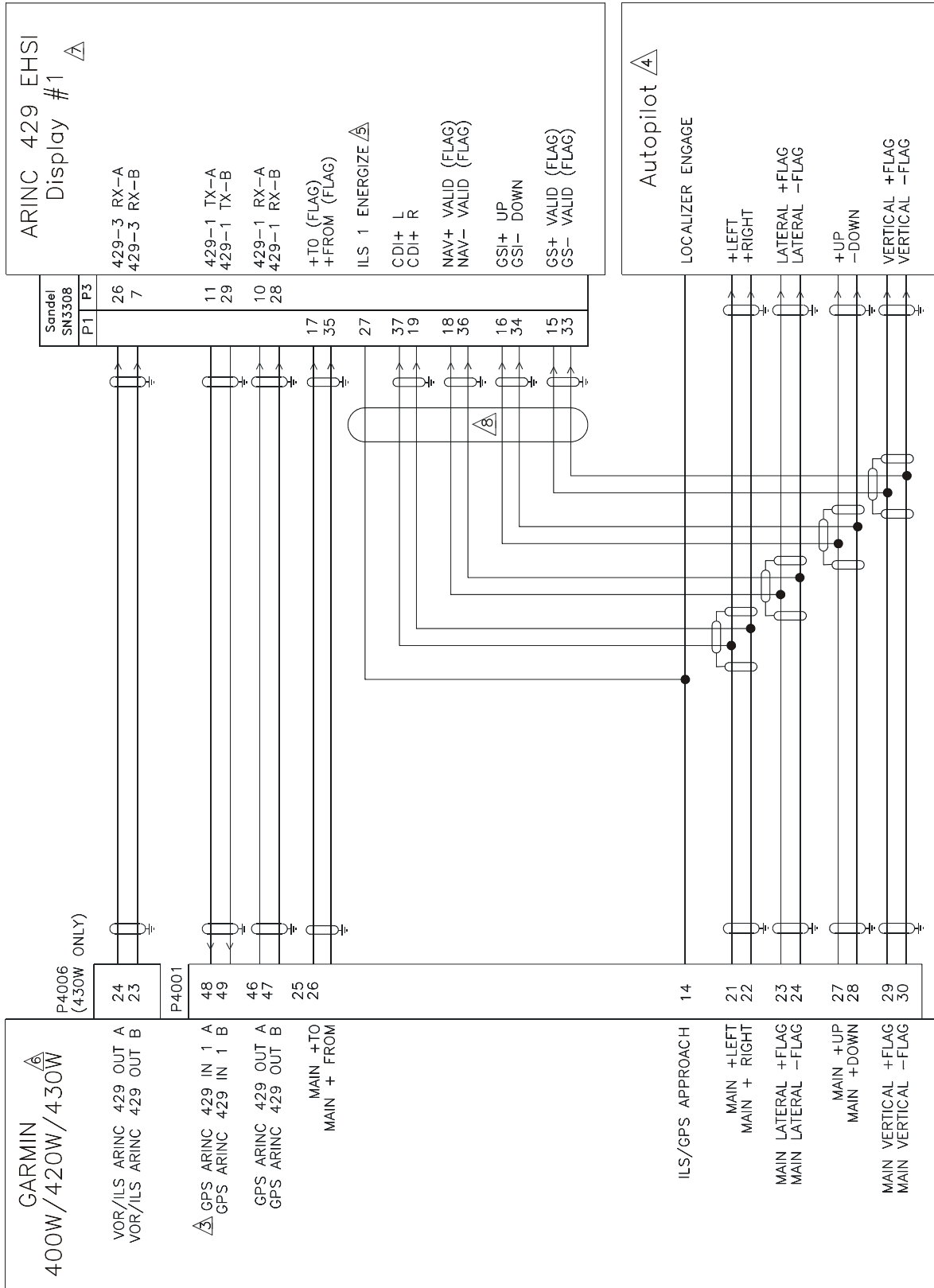

Figure H-12. ARINC 429 Sandel EHSI Interconnect (One 400W Series Unit, One Sandel SN3308)
Sheet 1 of 2

1. ALL WIRES 24 AWG OR LARGER UNLESS OTHERWISE NOTED
2. AT GNS 400W SERIES UNIT, TERMINATE SHIELD GROUNDS TO THE CONNECTOR BACKSHELL OR USE CARD-EDGE CONNECTOR TO TERMINATE SHIELD GROUNDS TO BACK PLATE – THE SHIELD LEADS MUST BE LESS THAN 3.0 INCHES. CONNECT OTHER SHIELD GROUNDS TO AIRCRAFT CHASSIS WITH AS SHORT A CONDUCTOR AS PRACTICAL.
3. IF THE GPS ARINC 429 IN 1 PORT (P4001-48 AND -49) IS ALREADY USED FOR ANOTHER PURPOSE, THE GPS ARINC 429 IN 2 PORT (P4001-50 AND -51) MAY BE CONNECTED INSTEAD.
4. AUTOPILOT SHOWN FOR REFERENCE ONLY. REFER TO THE APPROPRIATE INTERCONNECT DIAGRAM.
5. USE ILS ENERGIZE 2 (P1-8) IF GNS 400W SERIES UNIT IS BEING CONNECTED AS GPS2/NAV2.
6. GNS 430W SETUP ITEMS:

MAIN ARINC 429 CONFIG:	IN 1:	LOW, SANDEL EHSI
	OUT:	LOW, GAMA 429 GRPH W/INT
	SDI:	LNAV 1
	VNAV:	DISABLE LABELS
VOR/LOC/GS ARINC 429 CONFIG:	SPEED RX:	LOW TX: LOW
	SDI:	VOR/ILS 1
7. SANDEL SN3308 SETUP ITEMS:

LNAV1/2 SELECT: GNS 430 (ARINC)	ANNUN:	SERIAL	RELAY SENSE:	NAV-2:	OFF
	COURSE:	OBS/LEG		GPS-1:	OFF
	DEVIATION:	ANALOG/IN		GPS-2:	OFF
	OBS ROT:	NORMAL		CDI SRC SEL:	OFF
	OBS CAL:	000.0		RCVR 1/2:	OFF
NAV CHANGE: NAV 1/2 ENABLE:	YES				
	PORT:	429 PORT-3*			

* NAV 1/2 MUST TEMPORARILY BE SET TO "ANALOG" AND "ILS" MUST BE SET TO "VALID LOW" FOR PROPER OPERATION OF THE VDI.
8. ANALOG CONNECTIONS TO THE SN3308 ARE REQUIRED TO ALLOW VERTICAL GUIDANCE TO BE DISPLAYED FOR GPS APPROACHES.
9. REFER TO MANUFACTURER'S DOCUMENTATION FOR COMPLETE PINOUT AND INTERCONNECT INFORMATION.

Figure H-12. ARINC 429 Sandel EHSI Interconnect (One 400W Series Unit, One Sandel SN3308)
 Sheet 2 of 2

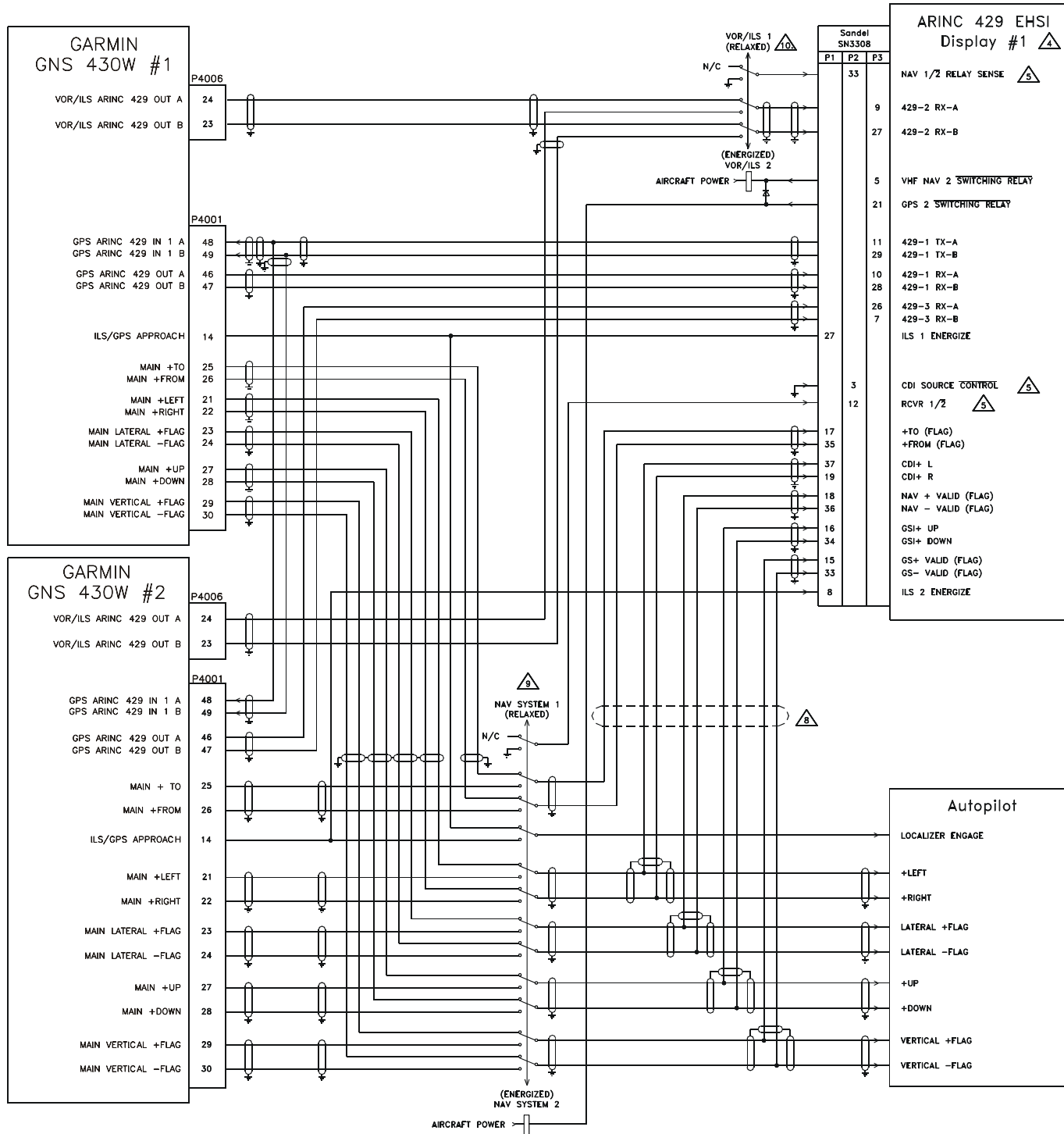

Figure H-13. ARINC 429 Sandel EHSI Interconnect (Two GNS 430W, One Sandel SN3308)
Sheet 1 of 2

NOTES:

1. ALL WIRES 24 AWG OR LARGER UNLESS OTHERWISE NOTED.
2. AT GNS 400W SERIES UNIT, TERMINATE SHIELD GROUNDS TO THE CONNECTOR BACKSHELL OR USE CARD-EDGE CONNECTOR TO TERMINATE SHIELD GROUNDS TO BACK PLATE – THE SHIELD LEADS MUST BE LESS THAN 3.0 INCHES. CONNECT OTHER SHIELD GROUNDS TO AIRCRAFT CHASSIS WITH AS SHORT A CONDUCTOR AS PRACTICAL.

3

GNS 430W #1 SETUP ITEMS:
MAIN ARINC 429 CONFIG:

IN 1: LOW, SANDEL EHSI
OUT: LOW, GAMA 429 GRPH W/INT
SDI: LNAV 1
VNAV: DISABLE LABELS

VOR/LOC/GS ARINC 429 CONFIG:

SPEED RX: LOW TX: LOW
SDI: VOR/ILS 1

GNS 430W #2 SETUP ITEMS:
MAIN ARINC 429 CONFIG:

IN 1: LOW, SANDEL EHSI
OUT: LOW, GAMA 429 GRPH W/INT
SDI: LNAV 2
VNAV: DISABLE LABELS

VOR/LOC/GS ARINC 429 CONFIG:

SPEED RX: LOW TX: LOW
SDI: VOR/ILS 2

4

SANDEL SN3308 #1 AND #2 SETUP ITEMS:
LNAV 1/2 SELECT: GNS 430 (ARINC)

NAV CHANGE: NAV-1 ENABLE: YES
PORT: 429 PORT-2*
NAV-2 ENABLE: YES
PORT: 429 PORT-2*

LNAV 1/2 CHANGE: ANNUN: SERIAL
COURSE: OBS/LEG
DEVIATION: ANALOG IN
OBS ROT: NORMAL
OBS CAL: 000.0

RELAY SENSE: NAV-2: P2-33
GPS-1: OFF
GPS-2: OFF
CDI SRC SEL: P2-3
RCVR 1/2: P2-12

*NAV 1/2 MUST TEMPORARILY BE SET TO ANALOG AND ILS MUST BE SET TO VALID LOW FOR PROPER OPERATION OF THE VDI.

5

THESE PINS ON THE SANDEL SN3308 ARE CONFIGURABLE AND CAN BE CHANGED TO SUIT THE PARTICULAR INSTALLATION.

6

AUTOPILOT SHOWN FOR REFERENCE ONLY. REFER TO APPROPRIATE AUTOPILOT INTERCONNECT DIAGRAM.

7. IF IT DESIRED TO USE THE NAV RECEIVERS AS A SOURCE FOR THE SN3308 BEARING POINTERS, IT IS RECOMMENDED THAT THE GNS 430W #1/#2 COMPOSITE OUTPUTS (P4006-8) BE CONNECTED TO THE SN3308 COMPOSITE INPUTS (P1-29 AND P1-10, #1 AND #2 RESPECTIVELY) AND THE SN3308 BRG NAV-1/NAV-2 BE SET TO 429+COMP .

8

ANALOG CONNECTIONS TO THE SN3308 ARE REQUIRED TO ALLOW VERTICAL GUIDANCE TO BE DISPLAYED FOR GPS APPROACHES.

9

USE RELAY AMERI-KING P/N AK-950-R12-()V OR EQUIVALENT.

10

USE RELAY LEACH P/N WN460-() () () OR EQUIVALENT.

11. REFER TO MANUFACTURER'S DOCUMENTATION FOR COMPLETE PINOUT AND INTERCONNECT INFORMATION.
12. A 500W SERIES UNIT MAY BE USED IN PLACE OF EITHER #1 OR #2 400W SERIES UNIT. SEE THE 500W INSTALLATION MANUAL.

Figure H-13. ARINC 429 Sandel EHSI Interconnect (Two GNS 430W, One Sandel SN3308)

Sheet 2 of 2

**THE TWO GNS 430W/TWO SN3308s
CONFIGURATION IS CURRENTLY
NOT SUPPORTED**

Figure H-14. ARINC 429 Sandel EHSI Interconnect (Two GNS 430W, Two Sandel SN3308)

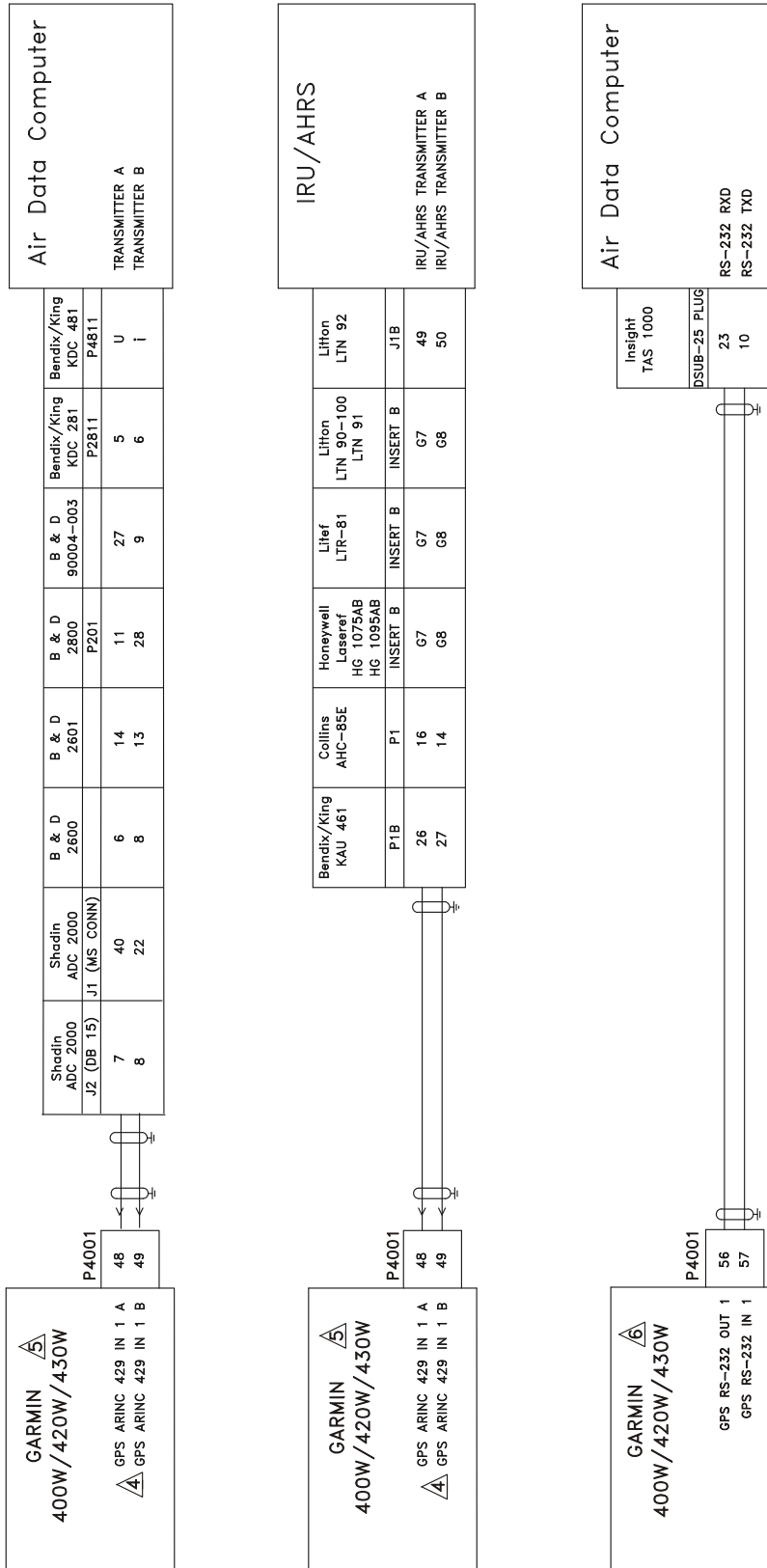

Figure H-15. ARINC 429/RS-232 Air Data/IRU/AHRS Interconnect
Sheet 1 of 2

NOTES:

1. ALL WIRES 24 AWG OR LARGER UNLESS OTHERWISE NOTED.
2. AT GNS 400W SERIES UNIT, TERMINATE SHIELD GROUNDS TO THE CONNECTOR BACKSHELL OR USE CARD-EDGE CONNECTOR TO TERMINATE SHIELD GROUNDS TO BACK PLATE – THE SHIELD LEADS MUST BE LESS THAN 3.0 INCHES. CONNECT OTHER SHIELD GROUNDS TO AIRCRAFT CHASSIS WITH AS SHORT A CONDUCTOR AS PRACTICAL.
3. LOWER CASE PIN DESIGNATORS ARE SHOWN AS UNDERLINED UPPER CASE LETTERS.
4. IF THE GPS ARINC 429 IN 1 PORT (P4001-48 AND -49) IS ALREADY USED FOR ANOTHER PURPOSE, THE GPS ARINC 429 IN 2 PORT (P4001-50 AND -51) MAY BE CONNECTED INSTEAD.
5. REFER TO SECTION 5.3.1 FOR ARINC 429 CHANNEL SETTINGS.
6. REFER TO SECTION 5.3.2 FOR RS-232 CHANNEL SETTINGS.
7. REFER TO MANUFACTURER'S DOCUMENTATION FOR COMPLETE PINOUT AND INTERCONNECT INFORMATION. PINOUTS OF OTHER UNITS SHOWN FOR REFERENCE ONLY.

Figure H-15. ARINC 429/RS-232 Air Data/IRU/AHRS Interconnect
Sheet 2 of 2

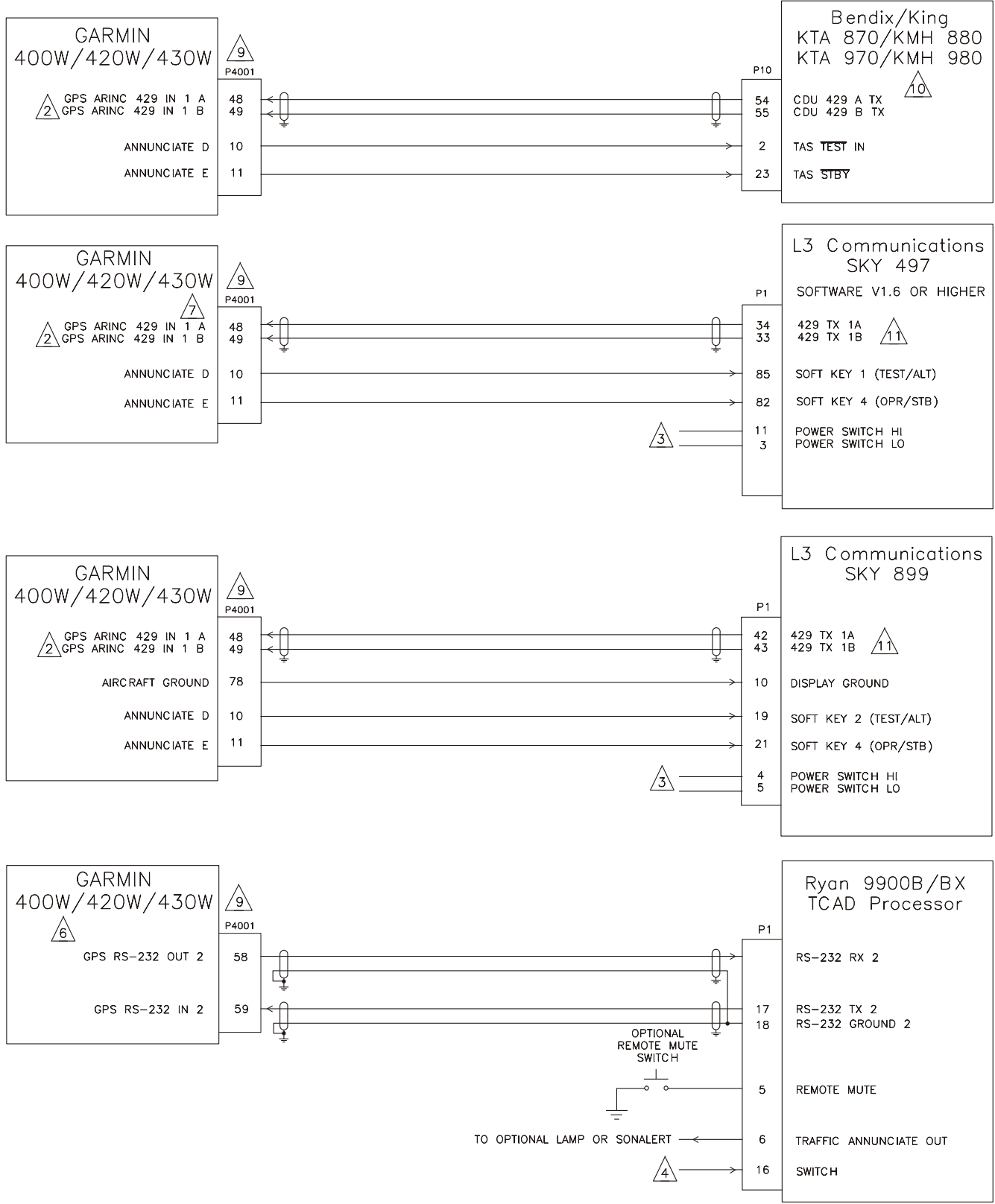
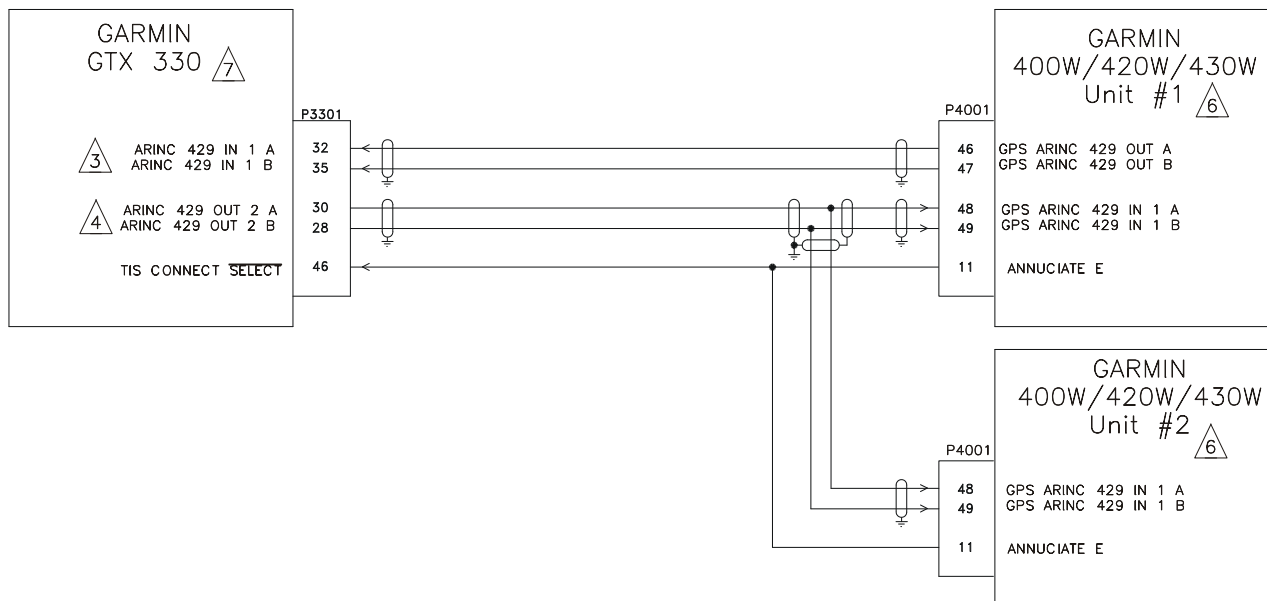

Figure H-16. Traffic Advisory System Interconnect
Sheet 1 of 2

-
- NOTES:
1. ALL WIRES 24 AWG OR LARGER UNLESS OTHERWISE NOTED
 2. IF THE GPS ARINC 429 IN 1 PORT (P4001-48 AND -49) IS ALREADY USED FOR ANOTHER PURPOSE, THE GPS ARINC 429 IN 2 PORT (P4001-50 AND -51) MAY BE CONNECTED INSTEAD.
 3. THE SKYWATCH POWER SWITCH PINS, SHOWN ON P1, SHOULD BE CONNECTED TOGETHER TO TURN THE PROCESSOR UNIT ON, AND OPEN TO TURN THIS UNIT OFF. IF A SKYWATCH CONTROL/DISPLAY UNIT IS NOT IN THE INSTALLATION, A DEDICATED SWITCH MAY BE REQUIRED TO TURN THE SKYWATCH PROCESSOR UNIT ON OR OFF.
 4. THE RYAN TCAD PROCESSOR SWITCH PIN (P1-16) SHOULD BE GROUNDED TO TURN THE PROCESSOR UNIT ON, AND OPEN TO TURN THIS UNIT OFF. IF A RYAN TCAD DISPLAY UNIT IS NOT IN THE INSTALLATION, A DEDICATED SWITCH MAY BE REQUIRED TO TURN THE TCAD PROCESSOR UNIT ON AND OFF.
 5. IF ANY OF THESE TRAFFIC SYSTEMS ARE INSTALLED WITHOUT A CONTROL/DISPLAY UNIT, A PLACARD IS REQUIRED NEAR THE 400W SERIES UNIT, INDICATING THAT A TRAFFIC ADVISORY SYSTEM IS INSTALLED, AND ITS DATA MAY BE DISPLAYED ON THE 400W SERIES UNIT.
 6. IN ORDER FOR RYAN TCAD TRAFFIC TO BE DISPLAYED ON THE 400W SERIES UNITS MAP PAGE, THE 400W SERIES MUST HAVE A DIGITAL HEADING SOURCE.
 7. IN ORDER FOR SKYWATCH DATA TO BE DISPLAYED ON THE 400W SERIES UNIT S MAP PAGE, THE 400W SERIES UNIT MUST HAVE A DIGITAL HEADING SOURCE, OR THE SKYWATCH MUST HAVE A SYNCHRO OR SERIAL HEADING SOURCE. A STEPPER HEADING SOURCE WILL NOT ALLOW SKYWATCH DATA TO BE DISPLAYED ON THE MAP PAGE.
 8. AT GNS 400W SERIES UNIT, TERMINATE SHIELD GROUNDS TO THE CONNECTOR BACKSHELL OR USE CARD-EDGE CONNECTOR TO TERMINATE SHIELD GROUNDS TO BACK PLATE - THE SHIELD LEADS MUST BE LESS THAN 3.0 INCHES. CONNECT OTHER SHIELD GROUNDS TO AIRCRAFT CHASSIS WITH AS SHORT A CONDUCTOR AS PRACTICAL.
 9. REFER TO SECTION 5.3.1 FOR ARINC 429 CHANNEL SETTINGS AND 5.3.2 FOR RS-232 SETTINGS. IF AN ARINC 429 TRAFFIC SOURCE IS USED, THE CORRESPONDING ARINC 429 INPUT MUST BE SET TO HIGH SPEED.
 10. KTA 870/KMH 880/KTA 970/KMH 980 SYSTEMS MUST HAVE TRAFFIC CONFIGURED FOR "CONTROLLER TYPE: DISCRETE" AND "DISPLAY VALID: IGNORE". 400W SERIES MAIN SOFTWARE VERSION 3.00 OR LATER IS REQUIRED FOR OPERATION WITH KTA 970/KMH 980.
 11. SKYWATCH MUST BE CONFIGURED FOR AN ARINC 735 TYPE 1 DISPLAY.
 12. REFER TO MANUFACTURER'S DOCUMENTATION FOR COMPLETE PINOUT AND INTERCONNECT INFORMATION. PINOUTS OF OTHER UNITS SHOWN FOR REFERENCE ONLY.

**Figure H-16. Traffic Advisory System Interconnect
Sheet 2 of 2**



NOTES:

1. ALL WIRES 24 AWG OR LARGER UNLESS OTHERWISE NOTED.
2. AT GNS 400W SERIES UNIT, TERMINATE SHIELD GROUNDS TO THE CONNECTOR BACKSHELL OR USE CARD-EDGE CONNECTOR TO TERMINATE SHIELD GROUNDS TO BACK PLATE – THE SHIELD LEADS MUST BE LESS THAN 3.0 INCHES. CONNECT OTHER SHIELD GROUNDS TO AIRCRAFT CHASSIS WITH AS SHORT A CONDUCTOR AS PRACTICAL.
3. ARINC 429 IN 1 (P3301-32 AND -35) INPUT ALLOWS AUTOMATED START AND STOP OF FLIGHT TIMER AND PLACES THE TRANSPONDER IN GROUND (GND) MODE UPON LANDING.
4. IF EXTERNAL STBY SELECT IS CONNECTED IN THIS INSTALLATION USE GTX 330 ARINC 429 OUT 1 A AND 1 B, (PINS 37 AND 34) RATHER THAN ARINC 429 OUT 2 A AND 2 B (PINS 30 AND 28) SHOWN. ALTITUDE DATA WILL NOT BE TRANSMITTED OVER ARINC 429 PORT 2 TO THE 400W SERIES UNIT WHEN EXTERNAL STBY SELECT IS GROUNDED.
5. WHEN TIS IS USED IN THE AIRCRAFT DO NOT CONNECT ANOTHER TRAFFIC SYSTEM TO THE SAME 400W SERIES UNIT.
6. GNS 400W SERIES SETUP ITEMS:
 MAIN ARINC 429 CONFIG: IN 1: HIGH, GARMIN GTX 330
 OUT: SET TO MATCH INSTALLATION
7. GTX 330 SETUP ITEMS:
 429 INPUT CHANNEL 1: GPS (SPEED SET TO MATCH GNS 400W #1 OUTPUT)
 429 OUTPUT CHANNEL 2: GARMIN W/TIS
8. A 500W SERIES UNIT MAY BE USED IN PLACE OF EITHER #1 OR #2 400W SERIES UNIT. SEE THE 500W INSTALLATION MANUAL.

Figure H-17. GTX 330 Interconnect

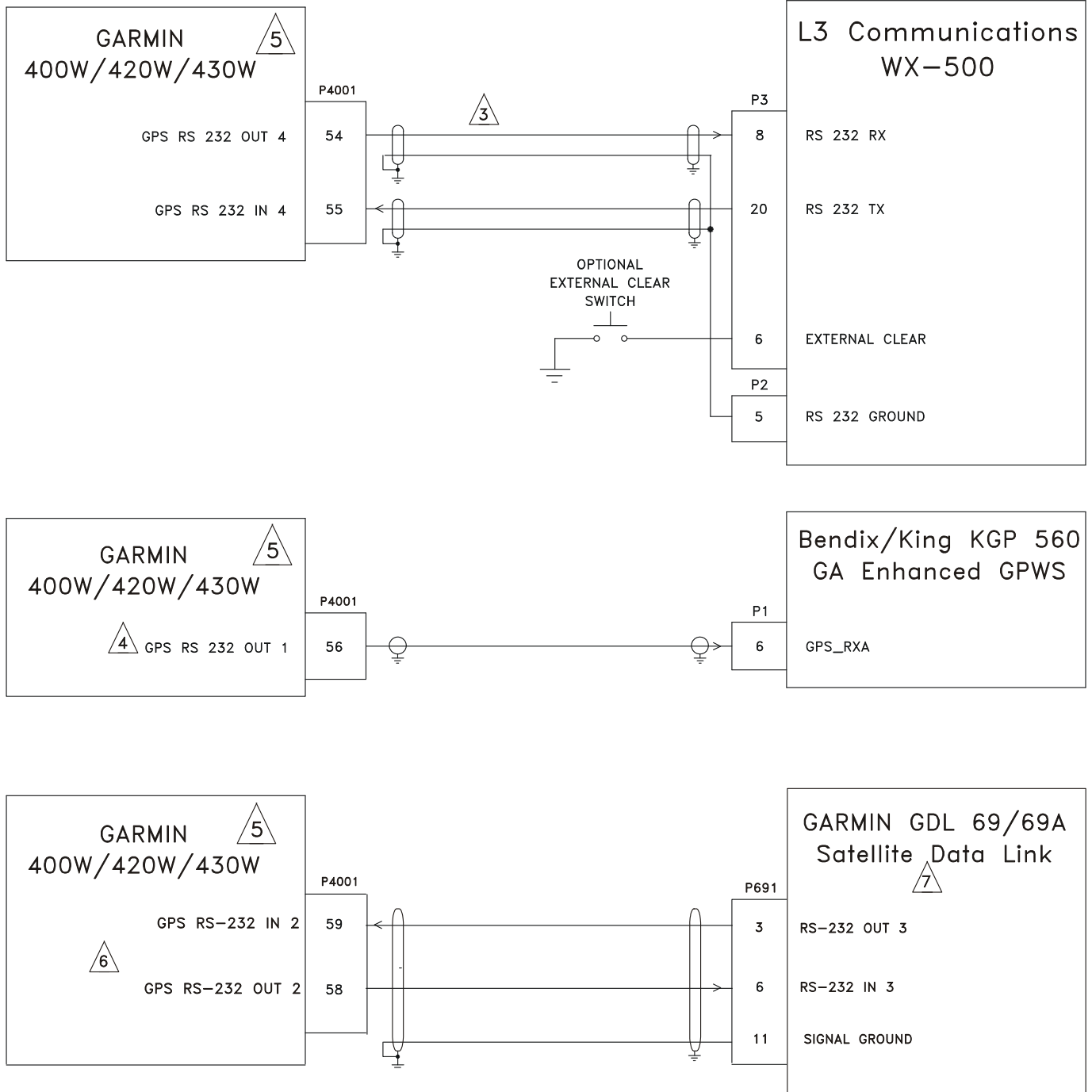

Figure H-18. Weather and Terrain Interconnect
Sheet 1 of 2

NOTES:

1. ALL WIRES 24 AWG OR LARGER UNLESS OTHERWISE NOTED
2. AT GNS 400W SERIES UNIT, TERMINATE SHIELD GROUNDS TO THE CONNECTOR BACKSHELL OR USE CARD-EDGE CONNECTOR TO TERMINATE SHIELD GROUNDS TO BACK PLATE – THE SHIELD LEADS MUST BE LESS THAN 3.0 INCHES. CONNECT OTHER SHIELD GROUNDS TO AIRCRAFT CHASSIS WITH AS SHORT A CONDUCTOR AS PRACTICAL.
3. IN ORDER FOR WX-500 DATA TO BE DISPLAYED ON THE 400W SERIES UNITS MAP PAGE. THE 400W SERIES UNIT MUST HAVE A DIGITAL HEADING SOURCE, OR THE WX-500 MUST HAVE A SYNCHRO OR SERIAL HEADING SOURCE. A STEPPER HEADING SOURCE WILL NOT ALLOW WX-500 DATA TO BE DISPLAYED ON THE MAP PAGE.
4. IF AN RS-232 OUTPUT PORT IS CONFIGURED FOR THE HONEYWELL EGPWS, THE CORRESPONDING RS-232 INPUT OF THE SAME PORT MAY NOT BE USED.
5. REFER TO SECTION 5.3.2 FOR RS-232 CHANNEL SETTINGS.
6. CONNECTION TO RS-232 PORT #2 OF THE 400W SERIES UNIT IS SHOWN. IF PORT #2 IS ALREADY IN USE, ANY OTHER AVAILABLE RS-232 PORT MAY BE USED AS WELL.
7. CONNECTION TO RS-232 PORT #2 OF THE GDL 69/69A MAY BE USED AS WELL.
8. REFER TO MANUFACTURER'S DOCUMENTATION FOR COMPLETE PINOUT AND INTERCONNECT INFORMATION. PINOUT OF OTHER UNITS SHOWN FOR REFERENCE ONLY.

**Figure H-18. Weather and Terrain Interconnect
Sheet 2 of 2**

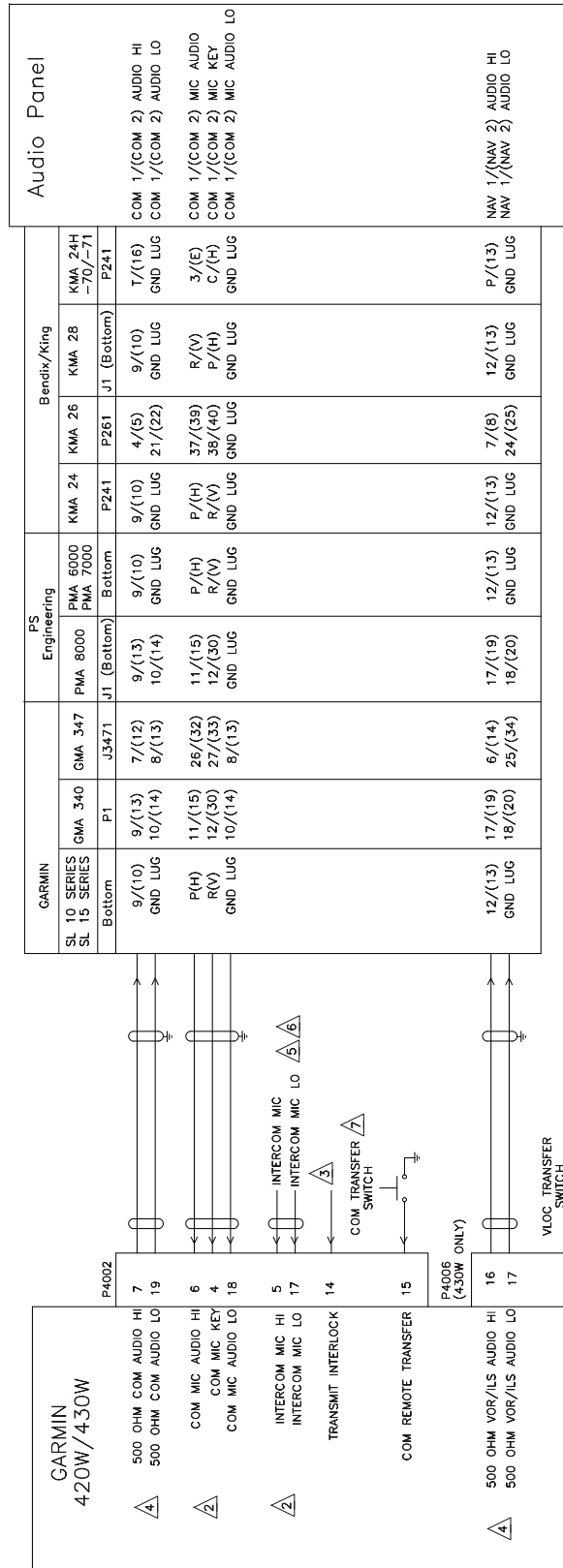

Figure H-19. Audio Panel Interconnect
Sheet 1 of 2

- NOTES:
1. ALL WIRES 24 AWG OR LARGER UNLESS OTHERWISE NOTED
 2. CONNECTING TWO MICROPHONES TO MIC AUDIO HI/LO OR INTERCOM MIC HI/LO AT THE SAME TIME MAY RESULT IN WEAK OR DISTORTED AUDIO. MIC ISOLATION RELAYS ARE RECOMMENDED SO THAT ONLY ONE MIC IS ACTIVE AT A TIME.
 3. CONNECT TRANSMIT INTERLOCK (P4002-14) TO THE OTHER TRANSCEIVERS MIC KEY TO MINIMIZE SQUELCH BREAKS ON THE 420W/430W COM.
 4. THE 500 OHM AUDIO OUTPUTS ARE BALANCED OUTPUTS AND THE LO OUTPUTS MUST BE CONNECTED. IF THE AUDIO PANEL DOES NOT HAVE A LO INPUT, IT SHOULD BE CONNECTED TO A GROUND LUG AT THE AUDIO PANEL.

5. THE 420W/430W INTERCOM FUNCTION SHOULD ONLY BE USED IF THERE IS NO OTHER INTERCOM SYSTEM IN THE AIRCRAFT.
MICROPHONE SWITCH (DPDT)

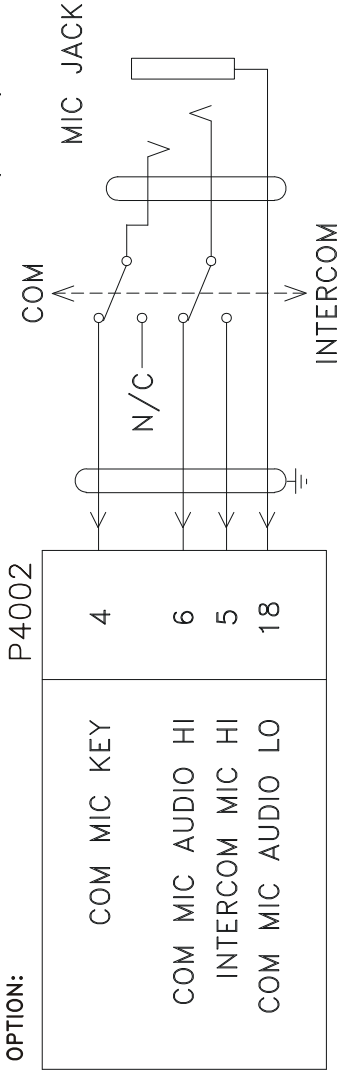
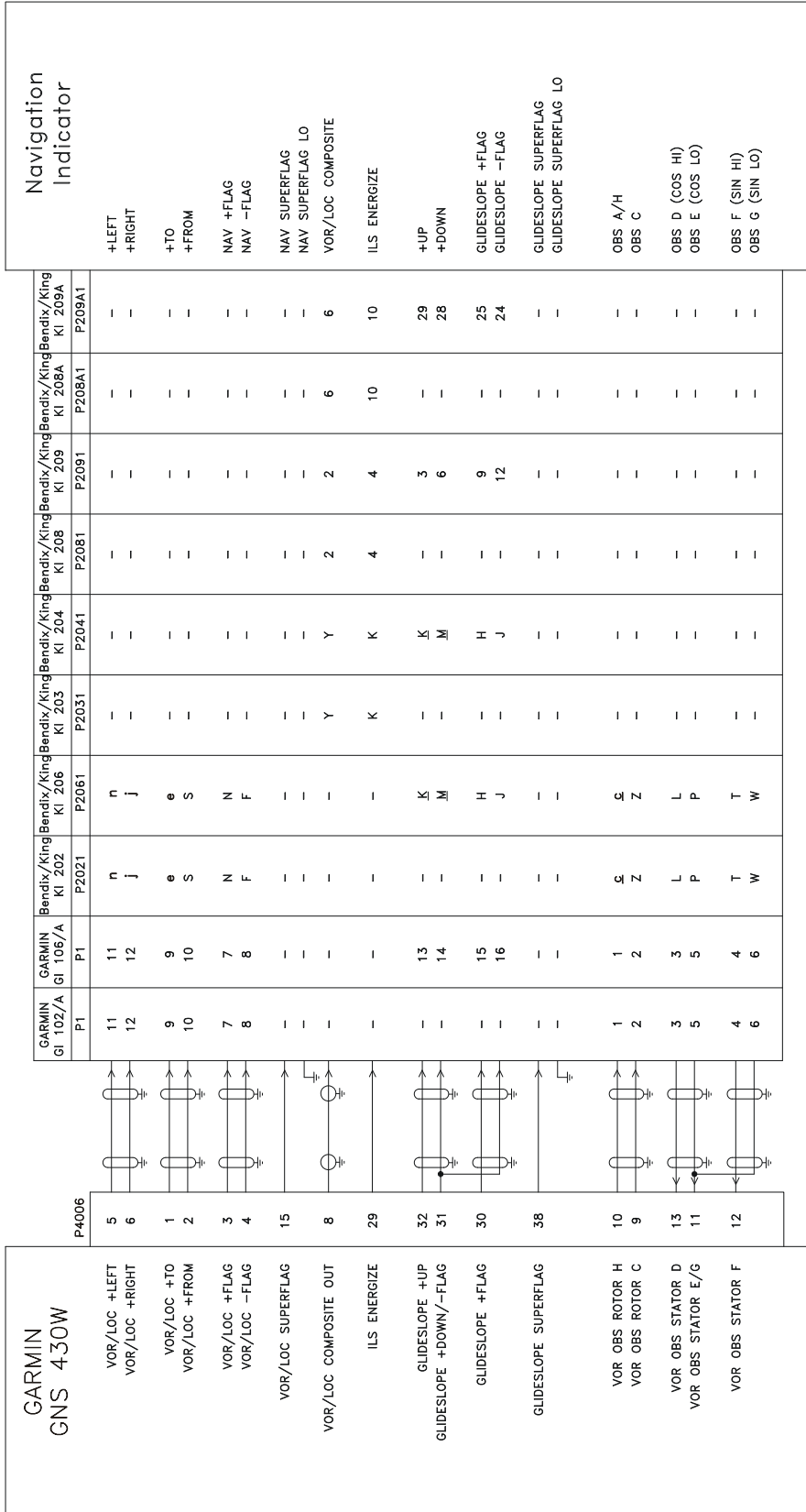

Figure H-19. Audio Panel Interconnect
Sheet 2 of 2

6. THE COM REMOTE TRANSFER INPUT (P4002-15) MAY BE USED FOR EMERGENCY OPERATION OF THE COM TRANSMITTER. IF THE REMOTE TRANSFER SWITCH IS ACTIVE FOR TWO SECONDS, THE ACTIVE COM FREQUENCY WILL CHANGE TO 121.50 MHZ.
8. REFER TO MANUFACTURER'S DOCUMENTATION FOR COMPLETE PINOUT AND INTERCONNECT INFORMATION. PINOUTS OF OTHER UNITS SHOWN FOR REFERENCE ONLY.
9. SHIELDS FOR AUDIO CABLES SHOULD BE GROUNDED AT ONE END (WITH LEADS LESS THAN 3.0 INCHES) AND LEFT FLOATING AT THE OTHER END. IF SHIELDED AUDIO CABLE IS CARRIED THROUGH DISCONNECT, CARRY SHIELD GROUND THROUGH DISCONNECT ON SEPARATE PIN.



NOTES:

1. ALL WIRES 24 AWG OR LARGER UNLESS OTHERWISE NOTED
2. LOWER CASE PIN DESIGNATORS ARE SHOWN AS UNDERLINED UPPER CASE LETTERS.
3. THIS INTERCONNECT APPLIES ONLY WHEN IT IS DESIRED FOR A SEPARATE INDICATOR TO DISPLAY GNS 430W VOR/ILS INFORMATION (REGARDLESS OF THE CDI BUTTON STATUS).
4. REFER TO MANUFACTURER'S DOCUMENTATION FOR COMPLETE PINOUT AND INTERCONNECT INFORMATION. PINOUTS OF OTHER UNITS SHOWN FOR REFERENCE ONLY.
5. AT GNS 400W SERIES UNIT, TERMINATE SHIELD GROUNDS TO THE CONNECTOR BACKSHELL OR USE CARD-EDGE CONNECTOR TO TERMINATE SHIELD GROUNDS TO BACK PLATE – THE SHIELD LEADS MUST BE LESS THAN 3.0 INCHES. CONNECT OTHER SHIELD GROUNDS TO AIRCRAFT CHASSIS WITH AS SHORT A CONDUCTOR AS PRACTICAL.

Figure H-20. VOR/ILS Indicator Interconnect

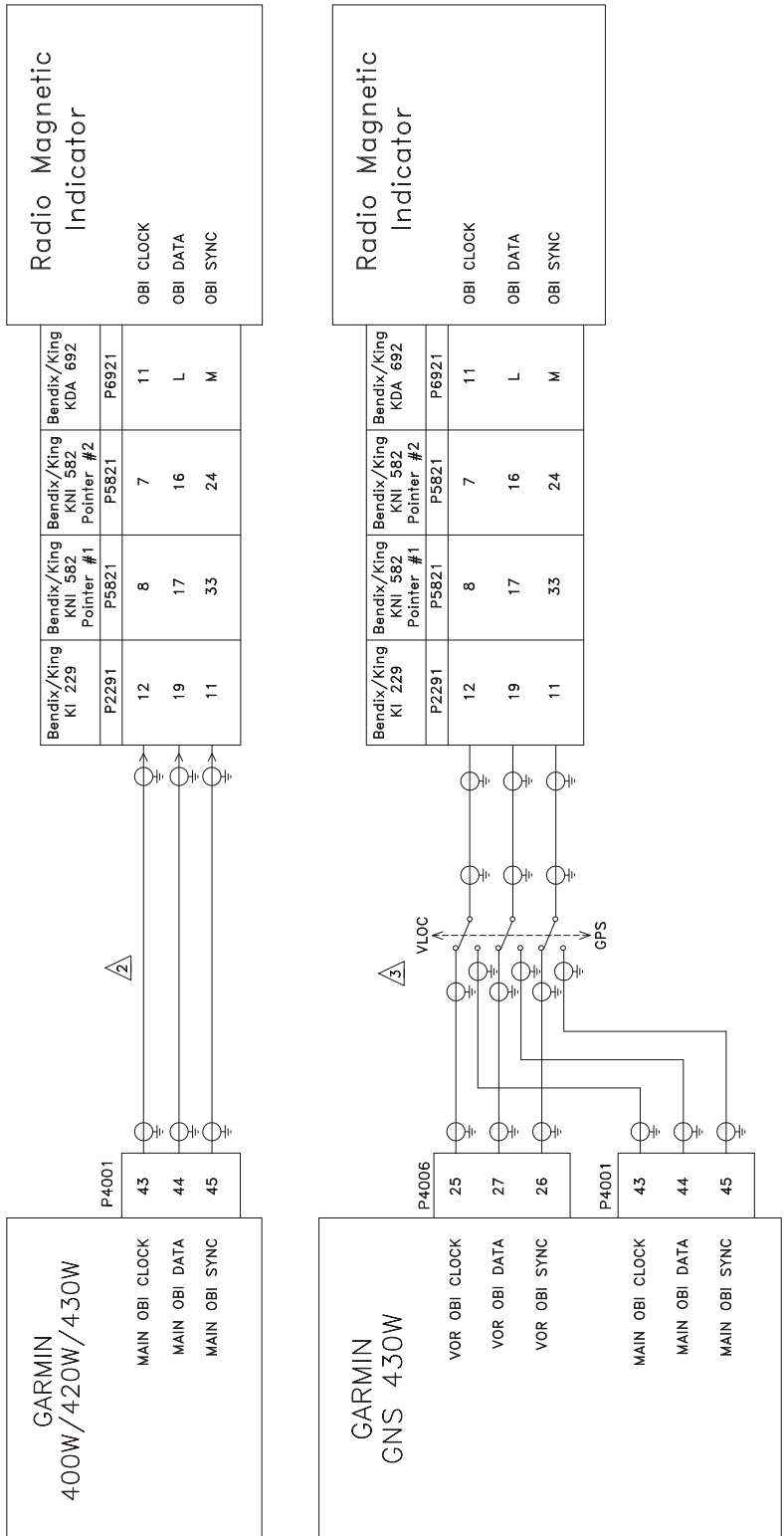

Figure H-21. RMI/OBI Interconnect

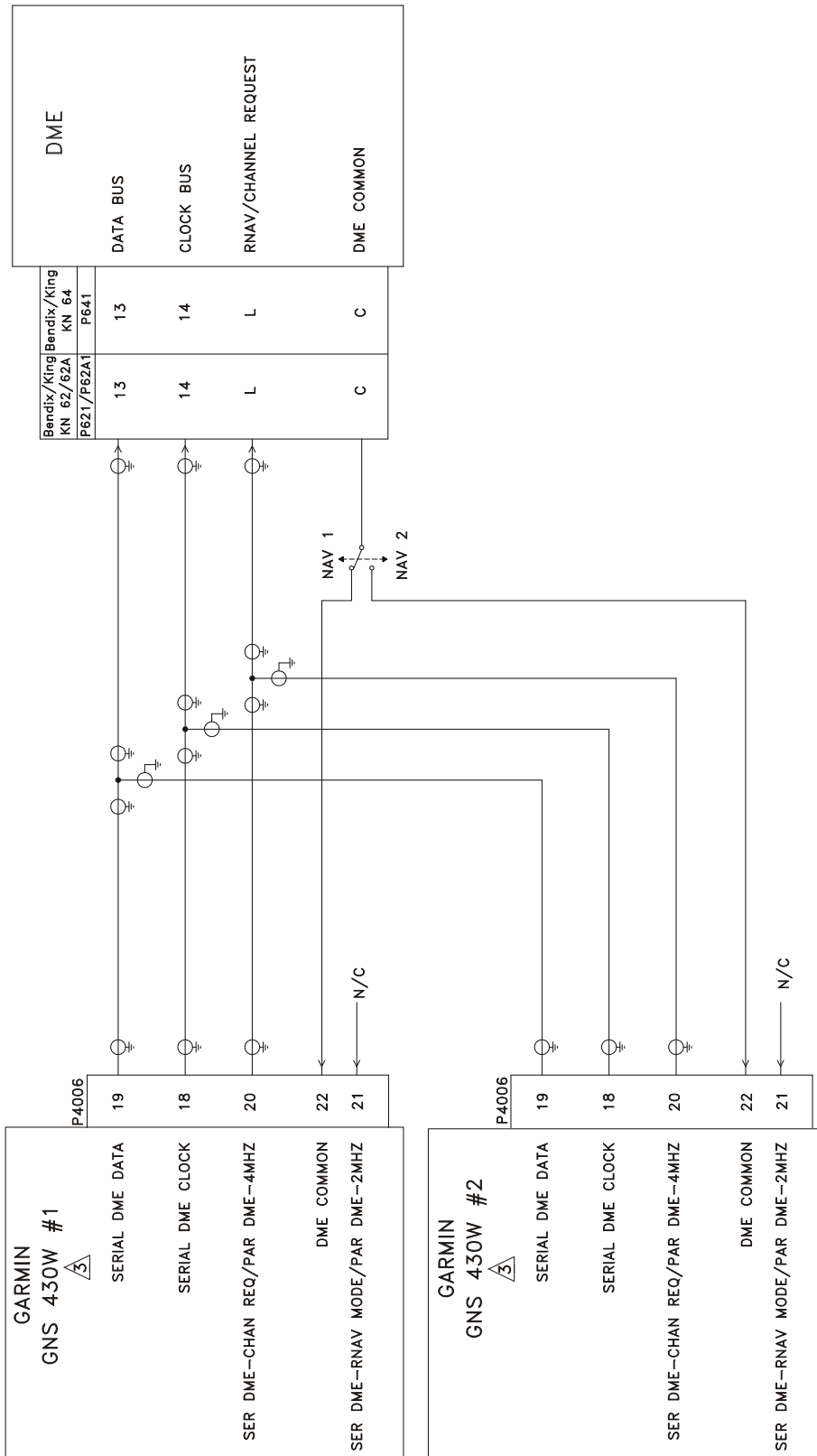

Figure H-22. King Serial Panel DME Tuning Interconnect

NOTES:

1. ALL WIRES 24 AWG OR LARGER UNLESS OTHERWISE NOTED
2. AT GNS 400W SERIES UNIT, TERMINATE SHIELD GROUNDS TO THE CONNECTOR BACKSHELL OR USE CARD-EDGE CONNECTOR TO TERMINATE SHIELD GROUNDS TO BACK PLATE -- THE SHIELD LEADS MUST BE LESS THAN 3.0 INCHES. CONNECT OTHER SHIELD GROUNDS TO AIRCRAFT CHASSIS WITH AS SHORT A CONDUCTOR AS PRACTICAL.
3. THE GNS 430W MUST BE CONFIGURED AT INSTALLATION TO OUTPUT KING SERIAL DME TUNING DATA UNDER THE DME CHANNEL MODE.
4. REFER TO MANUFACTURER'S DOCUMENTATION FOR COMPLETE PINOUT AND INTERCONNECT INFORMATION. PINOUTS OF OTHER UNITS SHOWN FOR REFERENCE ONLY.
5. A 500W SERIES UNIT MAY BE USED IN PLACE OF EITHER #1 OR #2 400W SERIES UNIT. SEE THE 500W INSTALLATION MANUAL.

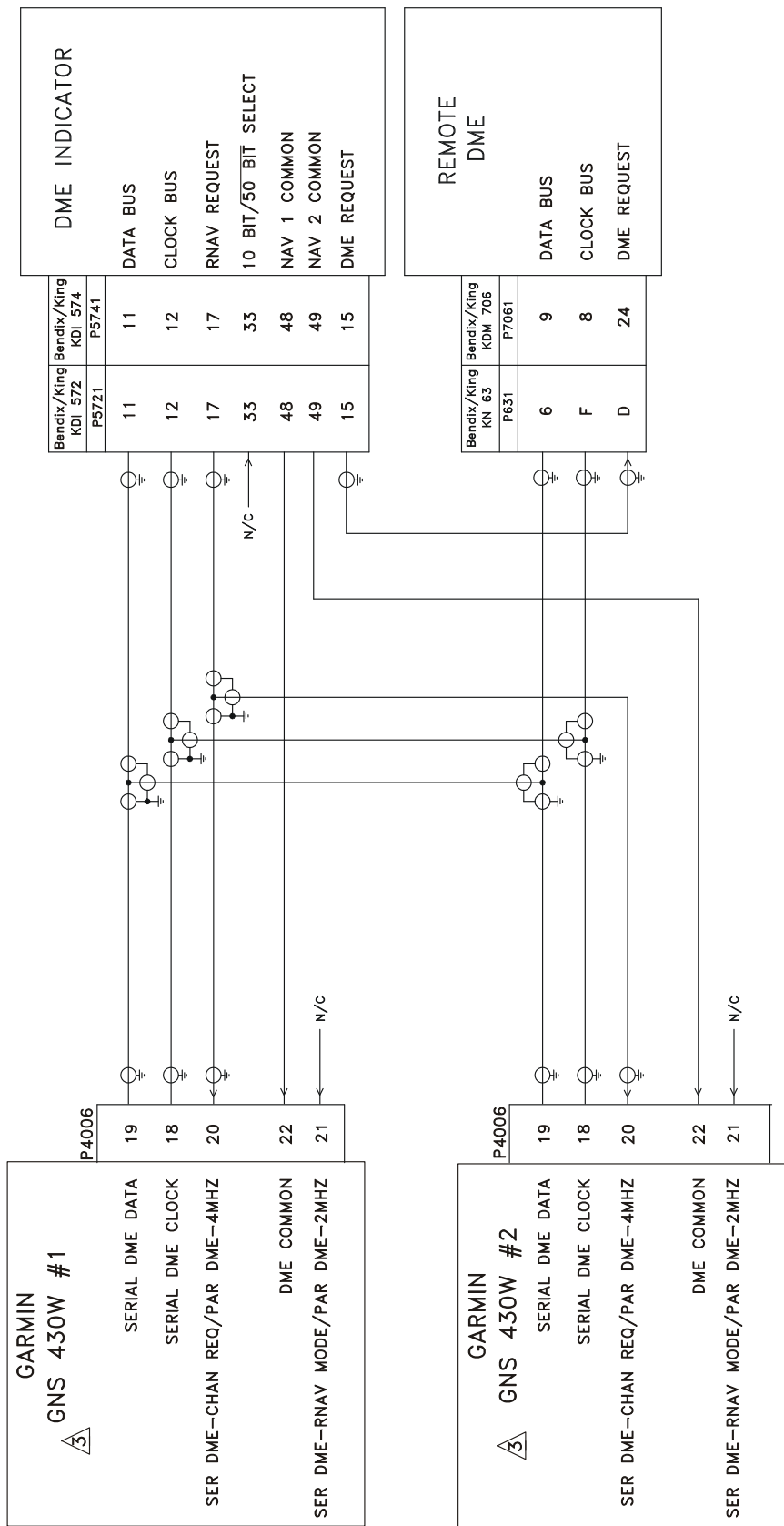

Figure H-23. King Serial Remote DME Tuning Interconnect

NOTES:

1. ALL WIRES 24 AWG OR LARGER UNLESS OTHERWISE NOTED
2. AT GNS 400W SERIES UNIT, TERMINATE SHIELD GROUNDS TO THE CONNECTOR BACKSHELL OR USE CARD-EDGE CONNECTOR TO TERMINATE SHIELD GROUNDS TO BACK PLATE -- THE SHIELD LEADS MUST BE LESS THAN 3.0 INCHES. CONNECT OTHER SHIELD GROUNDS TO AIRCRAFT CHASSIS WITH AS SHORT A CONDUCTOR AS PRACTICAL.
3. THE GNS 430W MUST BE CONFIGURED AT INSTALLATION TO OUTPUT KING SERIAL DME TUNING DATA UNDER THE DME CHANNEL MODE.
4. REFER TO MANUFACTURER'S DOCUMENTATION FOR COMPLETE PINOUT AND INTERCONNECT INFORMATION. PINOUTS OF OTHER UNITS SHOWN FOR REFERENCE ONLY.
5. A 500W SERIES UNIT MAY BE USED IN PLACE OF EITHER #1 OR #2 400W SERIES UNIT. SEE THE 500W INSTALLATION MANUAL.

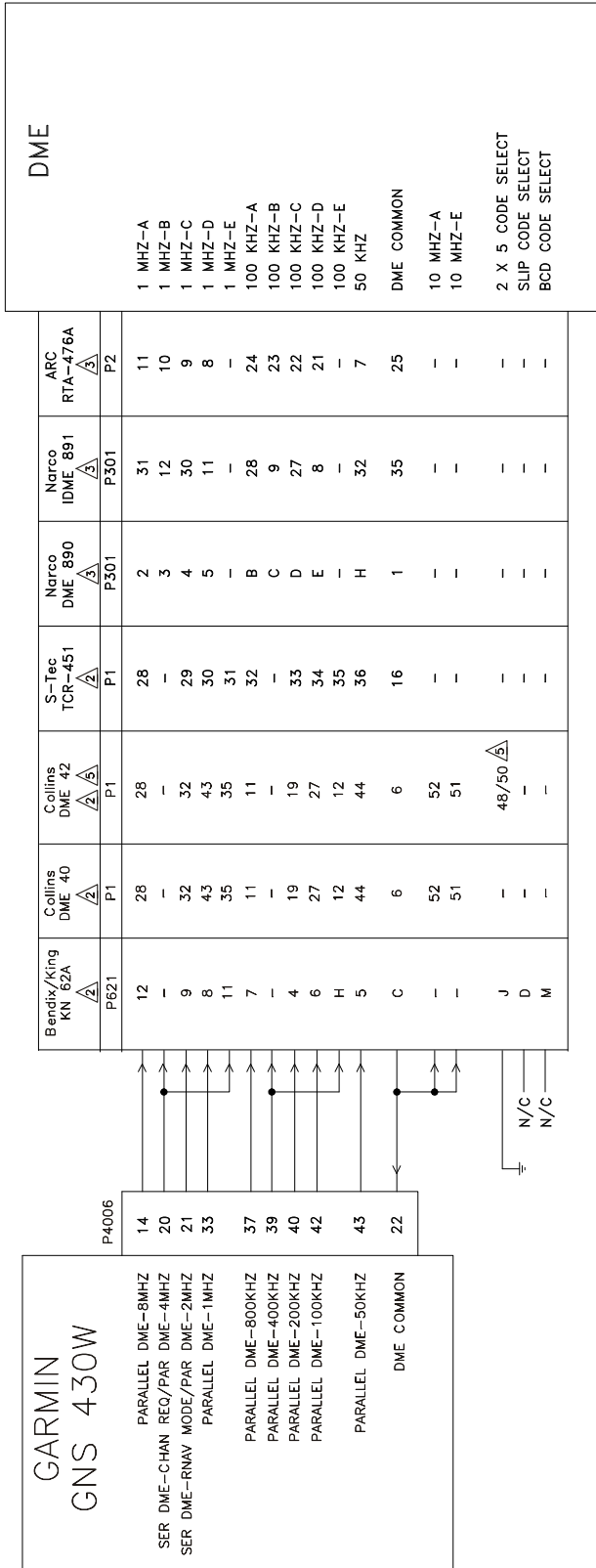
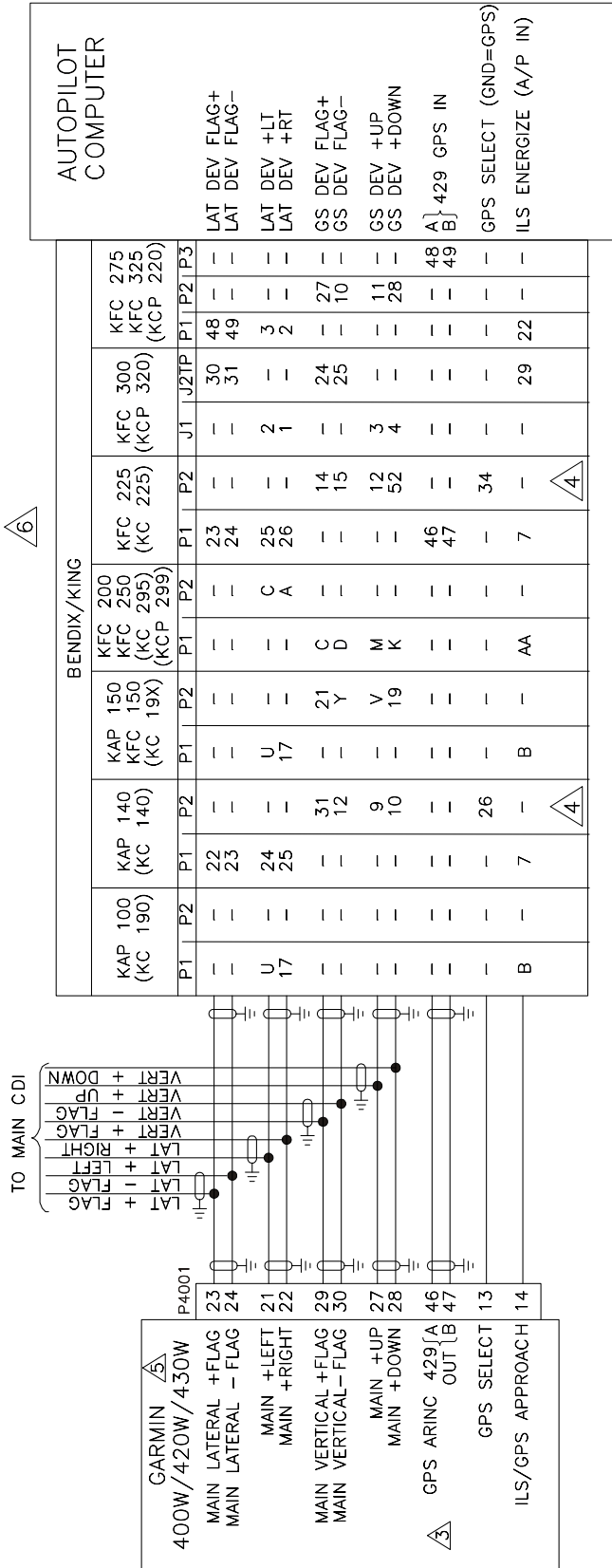

Figure H-24. Parallel 2 of 5 DME Tuning Interconnect

NOTES:

1. ALL WIRES 24 AWG OR LARGER UNLESS OTHERWISE NOTED
2. THE GNS 430W MUST BE CONFIGURED FOR PARALLEL 2x5 DME CHANNELING MODE FOR PROPER OPERATION WITH THIS MODEL OF DME TRANSCIEVER.
3. THE GNS 430W MUST BE CONFIGURED FOR NARCO 890/891 DME CHANNELING MODE FOR PROPER OPERATION WITH THIS MODEL OF DME TRANSCIEVER.
4. REFER TO MANUFACTURER'S DOCUMENTATION FOR COMPLETE PINOUT AND INTERCONNECT INFORMATION. PINOUTS OF OTHER UNITS SHOWN FOR REFERENCE ONLY.
5. DME 42 MUST BE STRAPPED FOR 2x5 TUNING. REFER TO DME 42 INSTALLATION MANUAL FOR STRAPPING INFORMATION.



NOTES:

1. ALL WIRES 24 AWG OR LARGER UNLESS OTHERWISE SPECIFIED.
 2. AT GNS 400W SERIES UNIT, TERMINATE SHIELD GROUNDS TO THE CONNECTOR BACKSHELL OR USE CARD-EDGE CONNECTOR TO TERMINATE SHIELD GROUNDS TO BACKPLATE. THE SHIELD LEADS MUST BE LESS THAN 3.0 INCHES. CONNECT OTHER SHIELD GROUNDS TO AIRCRAFT CHASSIS WITH AS SHORT A CONDUCTOR AS PRACTICAL.
- ③ ALL GAMA 429 CONFIGURATIONS OF THE GPS ARINC 429 OUTPUT PROVIDE DATA REQUIRED BY AUTOPILOT FOR GPSS. THE ARINC 429 CONFIGURATION CANNOT BE USED.
- ④ THE GPS SELECT OUTPUT MUST BE CONNECTED TO THE GPS SELECT INPUT OF THE AUTOPILOT. THIS OUTPUT IS GROUNDED WHEN IN GPS MODE, UNLESS A GPS APPROACH IS ACTIVE AND THE PILOT HAS ENABLED THE A/P APPROACH OUTPUTS. THIS WILL ALLOW THE AUTOPILOT TO CAPTURE THE GPS GLIDEPATH WHILE THE CDI IS DISPLAYING GPS INFORMATION. IF UPGRADING AN EXISTING 400 SERIES INSTALLATION, THE CONNECTION BETWEEN P4001-2 (GPS ANNUNCIATE) AND THE GPS SELECT INPUT ON THE AUTOPILOT MUST FIRST BE DISCONNECTED.
- ⑤ GNS 400W SERIES UNIT SETUP ITEMS
 MAIN SYSTEM CONFIG PAGE: DISCRETES – GPS SELECT: PROMPT (FOR KAP 140 AND KFC 225)
 GPS SELECT: AUTO (FOR ALL EXCEPT KAP 140 AND KFC 225)
- ⑥ IF AN EFIS IS INSTALLED, NONE OF THE CONNECTIONS SHOWN IN THIS FIGURE ARE REQUIRED. THESE AUTOPILOT SIGNALS ARE PROVIDED BY THE EFIS.

Figure H-25. Bendix/King Analog Autopilot Interconnect

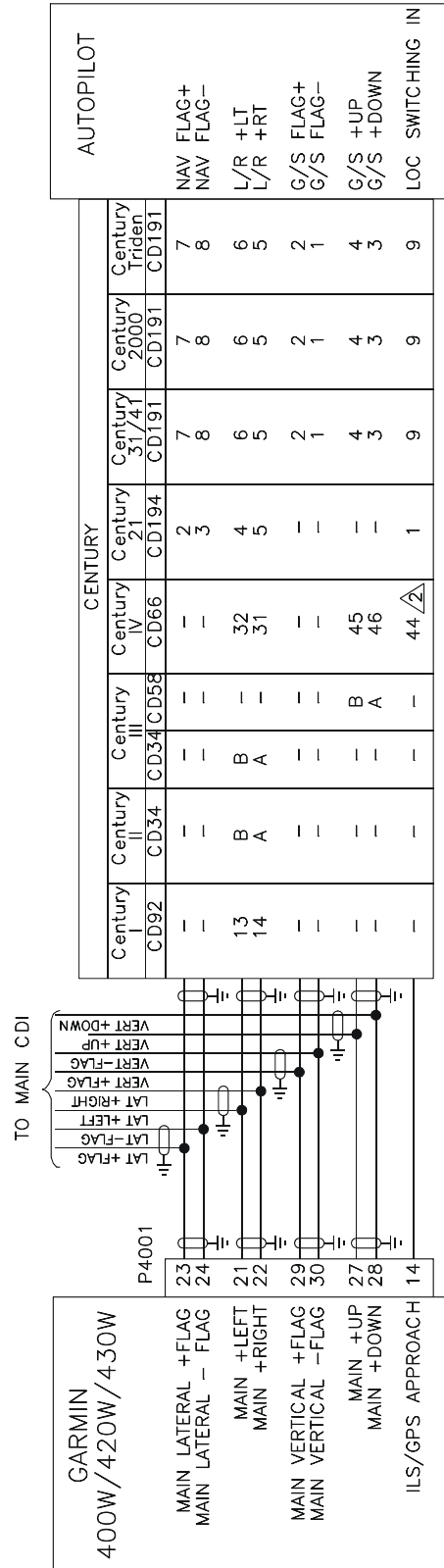
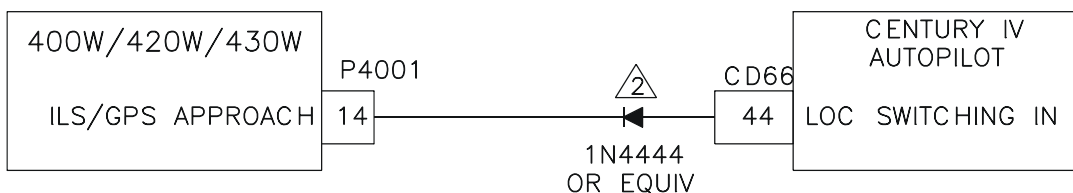
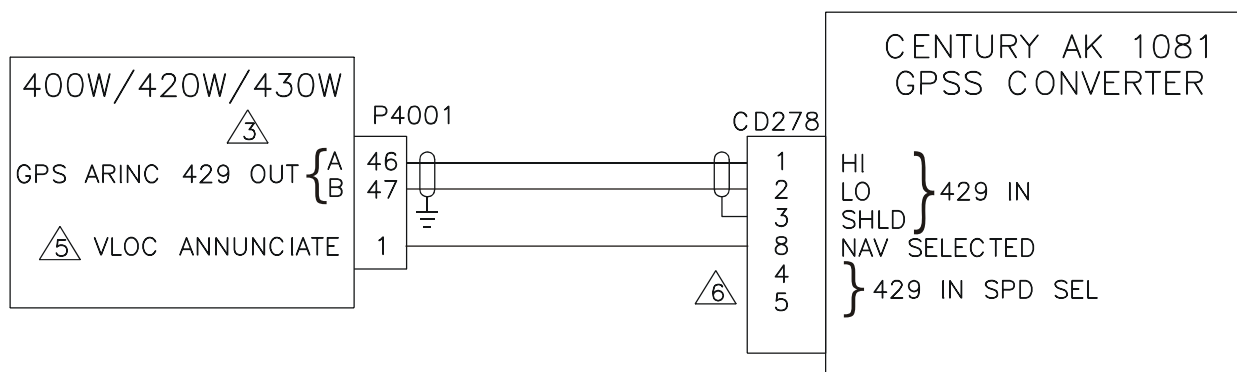

Figure H-26. Century Autopilot Interconnect
Sheet 1 of 2

CENTURY IV LOC SWITCHING CONNECTION



CENTURY AK 1081 GPSS CONVERTER CONNECTION



NOTES:

1. ALL WIRES 24 AWG OR LARGER UNLESS OTHERWISE SPECIFIED
- ② THE CENTURY IV REQUIRES THAT AN ISOLATION DIODE BE INSTALLED ON THE LOC SWITCHING INPUT AS SHOWN.
3. GNS 400W SERIES UNIT SETUP ITEMS
MAIN SYSTEM CONFIG PAGE: DISCRETES – GPS SELECT: AUTO
- ④ ALL CONFIGURATIONS OF THE GPS ARINC 429 OUTPUT PROVIDE GPSS DATA.
- ⑤ ONLY REQUIRED FOR GNS 430W.
- ⑥ INSTALL JUMPER AS REQUIRED TO SET AK 1081 ARINC 429 INPUT SPEED TO MATCH 400W SERIES UNIT OUTPUT SETTING. REFER TO MANUFACTURER'S DOCUMENTATION FOR ADDITIONAL DETAILS.

Figure H-26. Century Autopilot Interconnect
Sheet 2 of 2

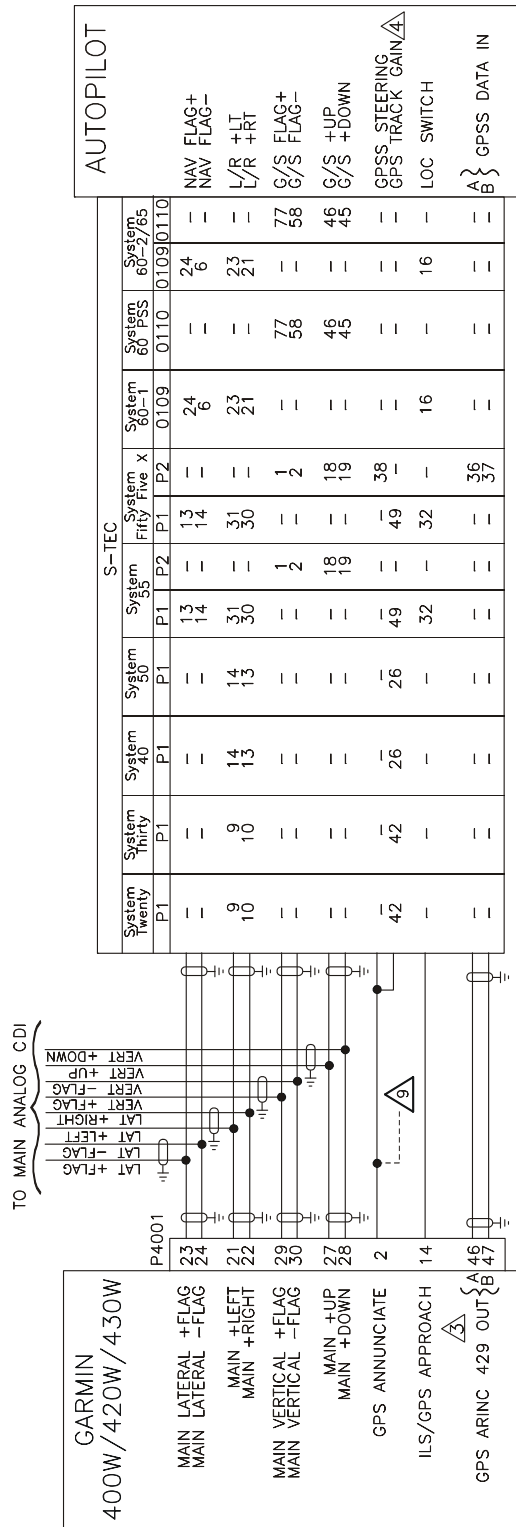

S-TEC ST-901 GPSS CONVERTER CONNECTION

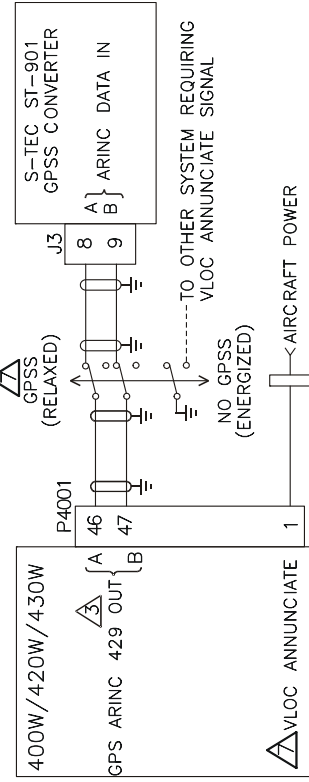

S-TEC ST-901 GPSS CONVERTER CONNECTION

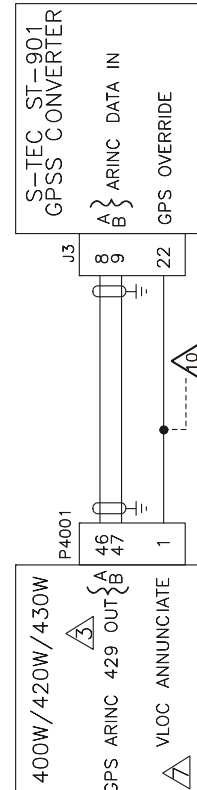
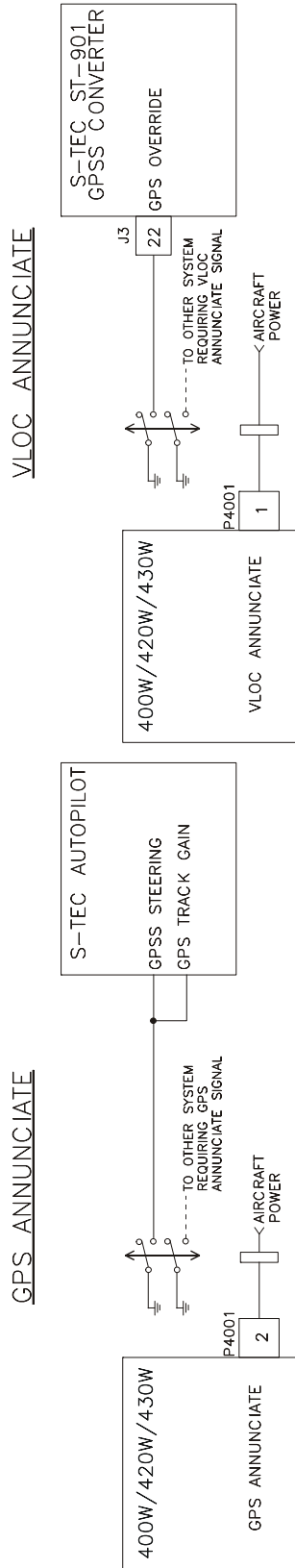

Figure H-27. S-TEC Autopilot Interconnect
Sheet 1 of 2

CONNECTION TO OTHER SYSTEMS



NOTES:

1. ALL WIRES 24 AWG OR LARGER UNLESS OTHERWISE SPECIFIED.
2. AT GNS 400W SERIES UNIT, TERMINATE SHIELD GROUNDS TO THE CONNECTOR BACKSHELL OR USE CARD-EDGE CONNECTOR TO TERMINATE SHIELD GROUNDS TO BACK PLATE – THE SHIELD LEADS MUST BE LESS THAN 3.0 INCHES. CONNECT OTHER SHIELD GROUNDS TO AIRCRAFT CHASSIS WITH AS SHORT A CONDUCTOR AS PRACTICAL.
3. ALL CONFIGURATIONS OF THE GPS ARINC 429 OUTPUT PROVIDE GPSS DATA.
4. GPS TRACK GAIN IS USED TO IMPROVE TRACKING WHEN GPS IS SELECTED ON THE CDI AND THE AUTOPILOT IS IN ANALOG NAVIGATION MODE (AND ROLL STEERING IS NOT ENGAGED.)
5. FOR CONVERTERS 01278-() S/N 600A AND ABOVE.
6. FOR CONVERTERS 01278-() S/N 599 AND BELOW.
7. ONLY REQUIRED FOR GNS 430W.
8. GNS 400W SERIES UNIT SETUP ITEMS
MAIN SYSTEM CONFIG PAGE: DISCRETES – GPS SELECT: AUTO
9. IF GPS ANNUNCIATE SIGNAL IS ONLY USED BY AUTOPILOT, THIS MAY BE CONNECTED DIRECTLY. IF GPS ANNUNCIATE SIGNAL IS REQUIRED BY OTHER SYSTEMS, CONNECT AS SHOWN IN FIGURE LABELED CONNECTION TO OTHER SYSTEMS.
10. IF VLOC ANNUNCIATE SIGNAL IS ONLY USED BY AUTOPILOT, THIS MAY BE CONNECTED DIRECTLY. IF VLOC ANNUNCIATE SIGNAL IS REQUIRED BY OTHER SYSTEMS, CONNECT AS SHOWN IN FIGURE LABELED CONNECTION TO OTHER SYSTEMS.

Figure H-27. S-TEC Autopilot Interconnect
Sheet 2 of 2

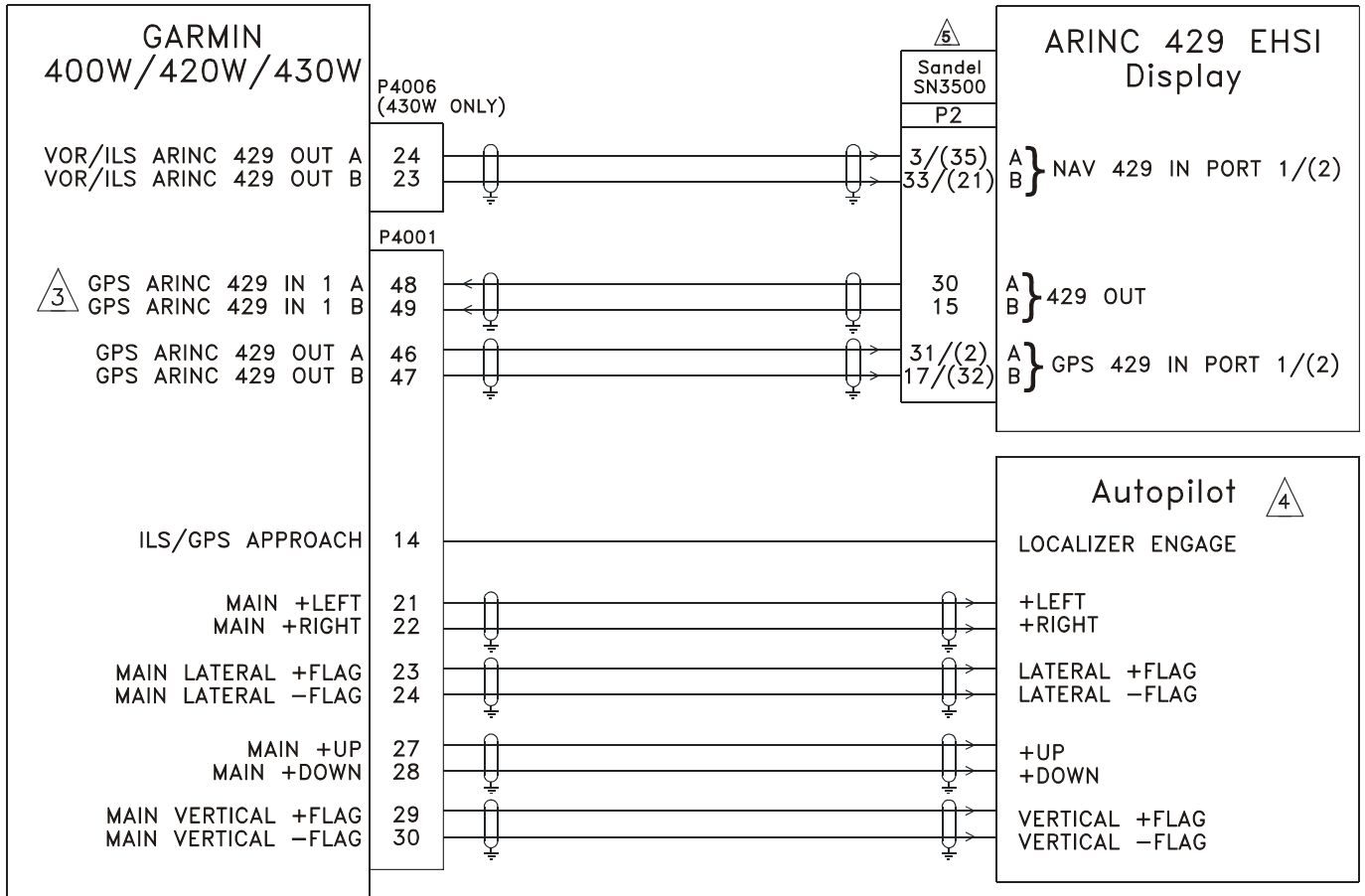

Figure H-28. ARINC 429 Sandel EHSI Interconnect (One 400W, One Sandel SN3500)
Sheet 1 of 2

-
1. ALL WIRES 24 AWG OR LARGER UNLESS OTHERWISE NOTED.
 2. AT GNS 400W SERIES UNIT, TERMINATE SHIELD GROUNDS TO THE CONNECTOR BACKSHELL OR USE CARD-EDGE CONNECTOR TO TERMINATE SHIELD GROUNDS TO BACK PLATE – THE SHIELD LEADS MUST BE LESS THAN 3.0 INCHES. CONNECT OTHER SHIELD GROUNDS TO AIRCRAFT CHASSIS WITH AS SHORT AS A CONDUCTOR AS PRACTICAL.
 3. IF THE GPS ARINC 429 IN 1 PORT (P4001-48 AND -49) IS ALREADY USED FOR ANOTHER PURPOSE, THE GPS ARINC 429 IN 2 PORT (P4001-50 AND -51) MAY BE CONNECTED INSTEAD.
 4. AUTOPILOT SHOWN FOR REFERENCE ONLY. REFER TO APPROPRIATE AUTOPILOT INTERCONNECT DIAGRAM.
 5. 400W SERIES SETUP ITEMS:

MAIN ARINC 429 CONFIG:	IN 1: LOW, SANDEL EHSI
	OUT: LOW, GAMA 429 GRPH W/INT
	SDI: LNAV 1
	VNAV: ENABLE LABELS
GNS 430W ONLY	
VOR/LOC/GS ARINC 429 CONFIG:	SPEED RX: LOW TX: LOW
	SDI: VOR/ILS 1
 6. SANDEL SN3500 SETUP ITEMS:

GPS 1/2: GNS 430 (ARINC)	ANNUN: SERIAL
	LAT DV: SERIAL
	VERT DV: SERIAL
	VERT ENA: SERIAL
NAV/ILS/DME-1/2:	
	NAV TYPE: 429 TO
 7. REFER TO MANUFACTURER'S DOCUMENTATION FOR COMPLETE PINOUT AND INTERCONNECT INFORMATION. PINOUTS OF OTHER UNITS SHOWN FOR REFERENCE ONLY.

Figure H-28. ARINC 429 Sandel EHSI Interconnect (One 400W, One Sandel SN3500)
Sheet 2 of 2

EXTERNAL NAVIGATION SOURCE SELECTION ANNUNCIATORS △3

STACO INDICATOR CONNECTION △5

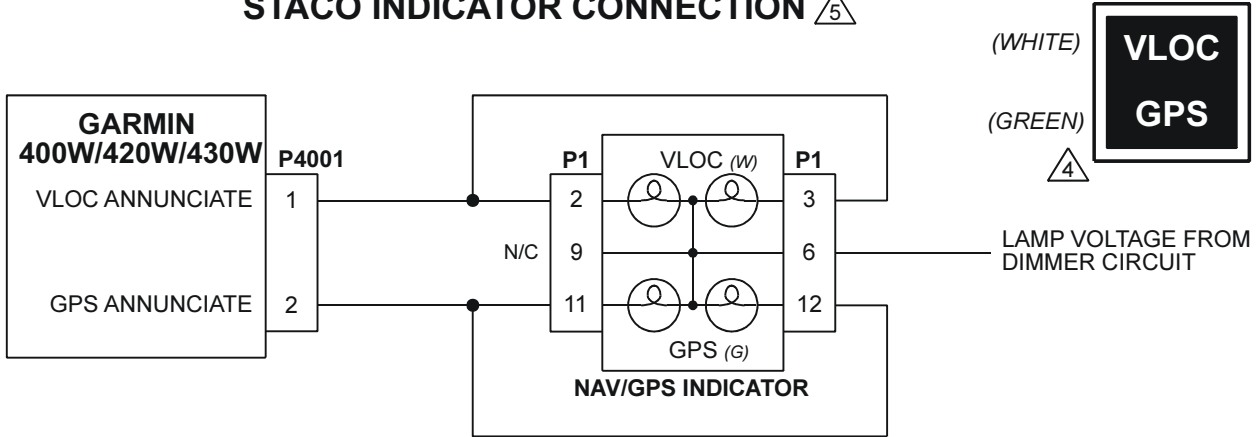

VIVISUN INDICATOR CONNECTION △6

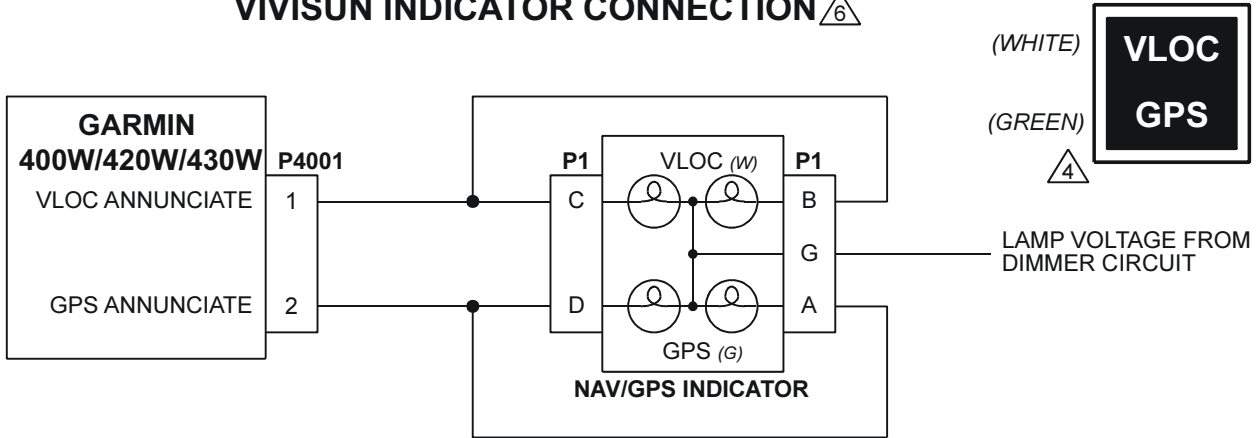

VIVISUN INDICATOR/SWITCH CONNECTION △7

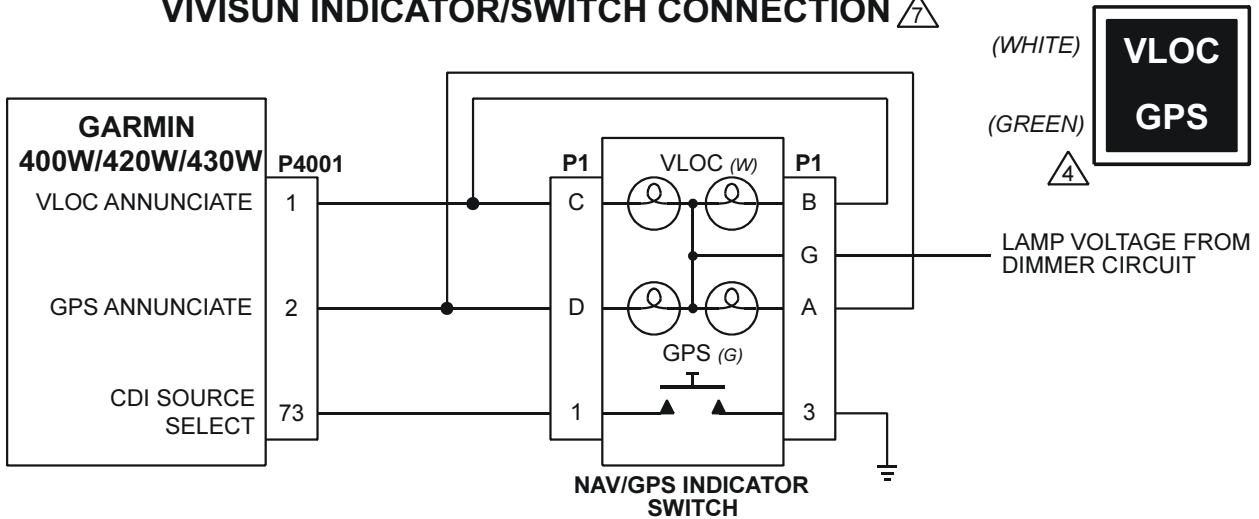
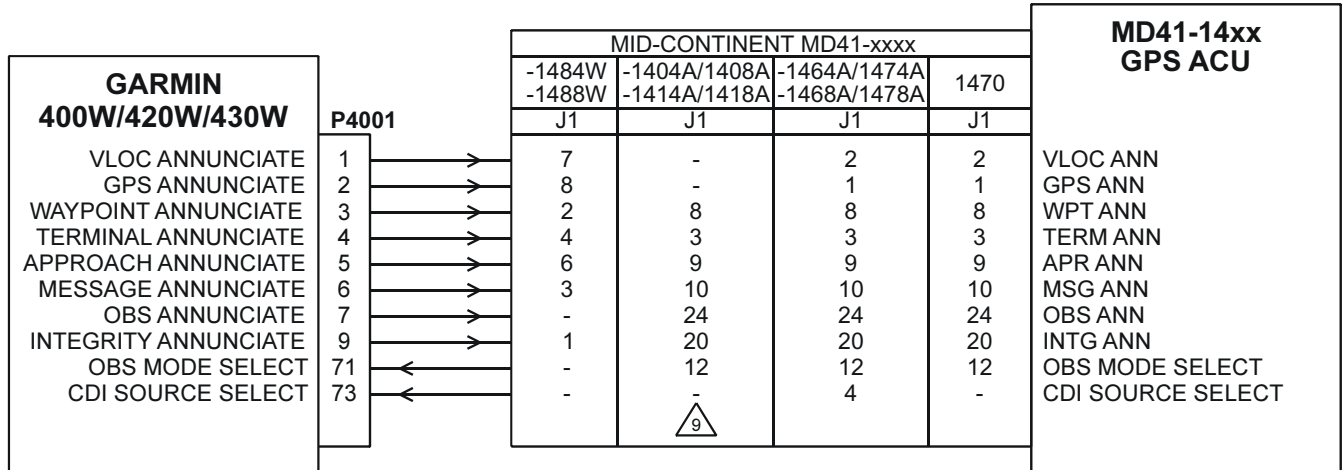

Figure H-29. External Navigation Source and GPS Annunciators
Sheet 1 of 2

EXTERNAL GPS ANNUNCIATIONS

MID-CONTINENT ACU CONNECTION ⁸



NOTES:

- ALL WIRES 24 AWG OR LARGER UNLESS OTHERWISE SPECIFIED.
- IF A CDI/HSI SOURCE SELECTION ANNUNCIATOR IS REQUIRED, INDICATORS ON THIS PAGE ARE SUITABLE TO MEET THE ANNUNCIATION REQUIREMENT.
- ³ THE PREFERRED ANNUNCIATION IS VLOC / GPS, ALTHOUGH NAV / GPS WILL BE ACCEPTABLE.
- ⁴ LEGENDS ARE HIDDEN (BLACK) WHEN NOT ILLUMINATED.
- ⁵ STACO SWITCH INDICATOR P/N 992561-1241762200 (14V SYSTEMS) AND P/N 992561-1241862200 (28V SYSTEMS) SHOWN.
- ⁶ VIVISUN INDICATOR P/N 95-40-17-B6-AW724 (28V SYSTEMS) SHOWN. INDICATOR MAY BE CONVERTED TO 14V OPERATION BY REPLACING 28V LAMPS WITH 14V LAMPS P/N 14-113.
- ⁷ VIVISUN INDICATOR WITH MOMENTARY SWITCH P/N 95-45-11-B6-AW724 (28V SYSTEMS) SHOWN. INDICATOR MAY BE CONVERTED TO 14V OPERATION BY REPLACING 28V LAMPS WITH 14V LAMPS P/N 14-113.
- ⁸ THESE UNITS ALSO PROVIDE NAVIGATION SOURCE SELECTION ANNUNCIATION. MID-CONTINENT ANNUNCIATION CONTROL UNITS FOR BOTH 14V AND 28V SYSTEMS SHOWN. THIS DIAGRAM IS PROVIDED TO SHOW INTERCONNECTION BETWEEN GNS 400W SERIES UNIT AND ACU ONLY. REFER TO MID-CONTINENT INSTALLATION MANUALS FOR ADDITIONAL INSTALLATION INFORMATION.
- ⁹ CDI SOURCE SELECTION AND ANNUNCIATION IS DONE WITH EXTERNAL RELAYS. REFER TO MID-CONTINENT INSTALLATION MANUAL FOR ADDITIONAL INSTALLATION INFORMATION.

Figure H-29. External Navigation Source and GPS Annunciators
Sheet 2 of 2

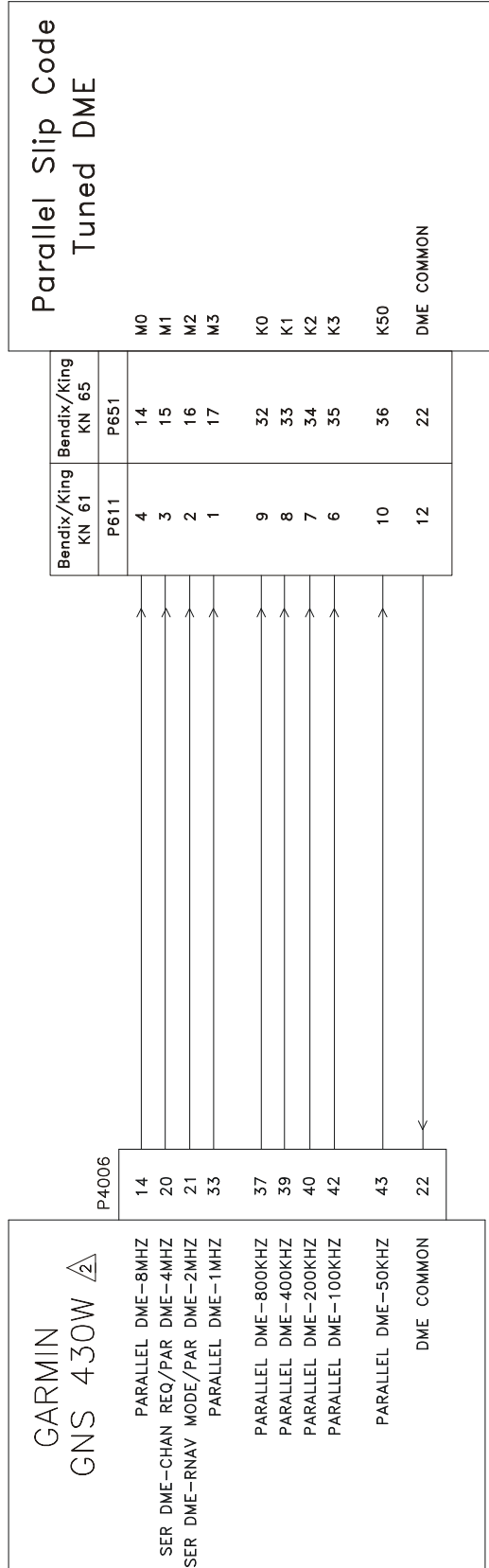

NOTES:

1. ALL WIRES 24 AWG OR LARGER UNLESS OTHERWISE NOTED
2. THE GNS 430W MUST BE CONFIGURED TO OUTPUT SLIP CODE DME TUNING DATA FOR PROPER OPERATION IN THIS CONFIGURATION.
3. REFER TO MANUFACTURER'S DOCUMENTATION FOR COMPLETE PINOUT AND INTERCONNECT INFORMATION. PINOUTS OF OTHER UNITS SHOWN FOR REFERENCE ONLY.

Figure H-30. Parallel Slip Code DME Tuning Interconnect

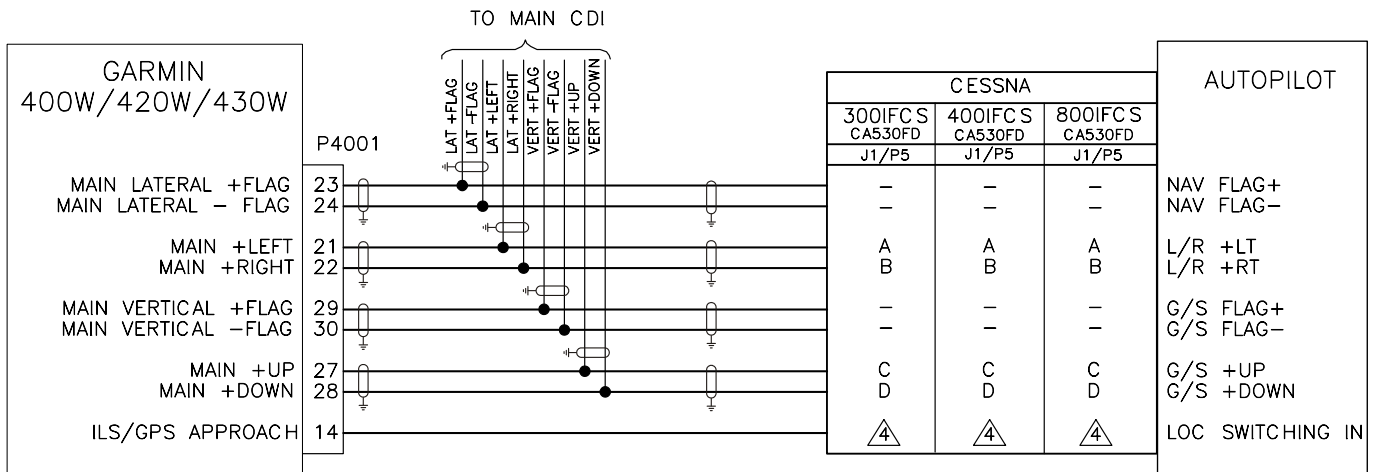
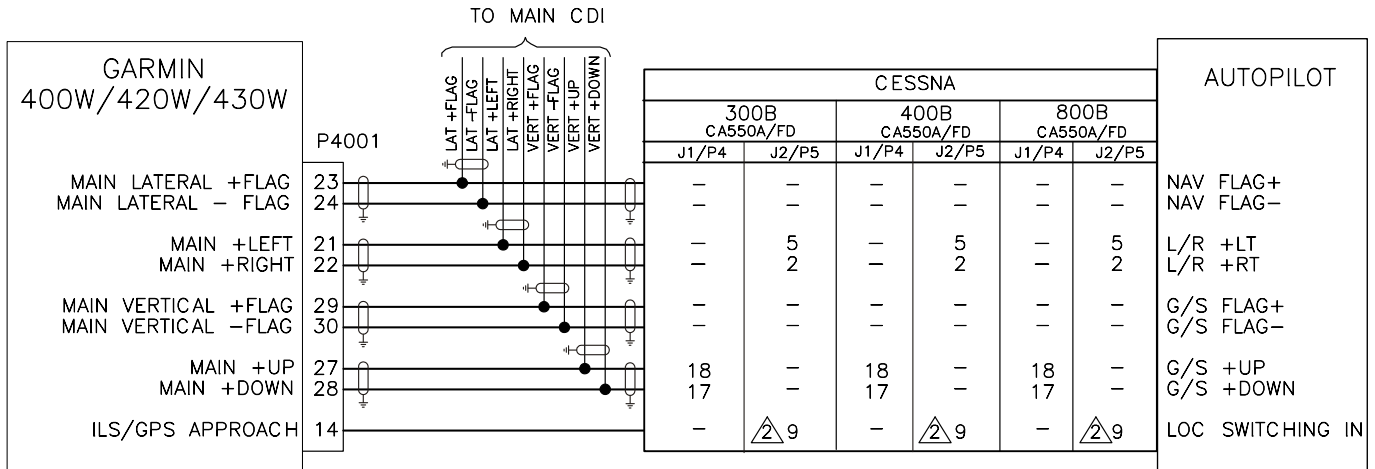

NOTES:

1. ALL WIRES 24 AWG OR LARGER UNLESS OTHERWISE SPECIFIED
- ② THE ILS/GPS APPROACH DISCRETE OUTPUT MUST ALSO BE CONNECTED TO THE BACK COURSE RELAY – REFER TO MANUFACTURER'S DOCUMENTATION FOR ADDITIONAL DETAILS.
3. GNS 400W SERIES UNIT SETUP ITEMS
MAIN SYSTEM CONFIG PAGE: DISCRETES – GPS SELECT: AUTO
- ④ REFER TO MANUFACTURER'S DOCUMENTATION FOR CORRECT CONNECTION OF VOR/LOC RELAY USING AN ACTIVE LOW INPUT.

Figure H-31. Cessna Autopilot Interconnect

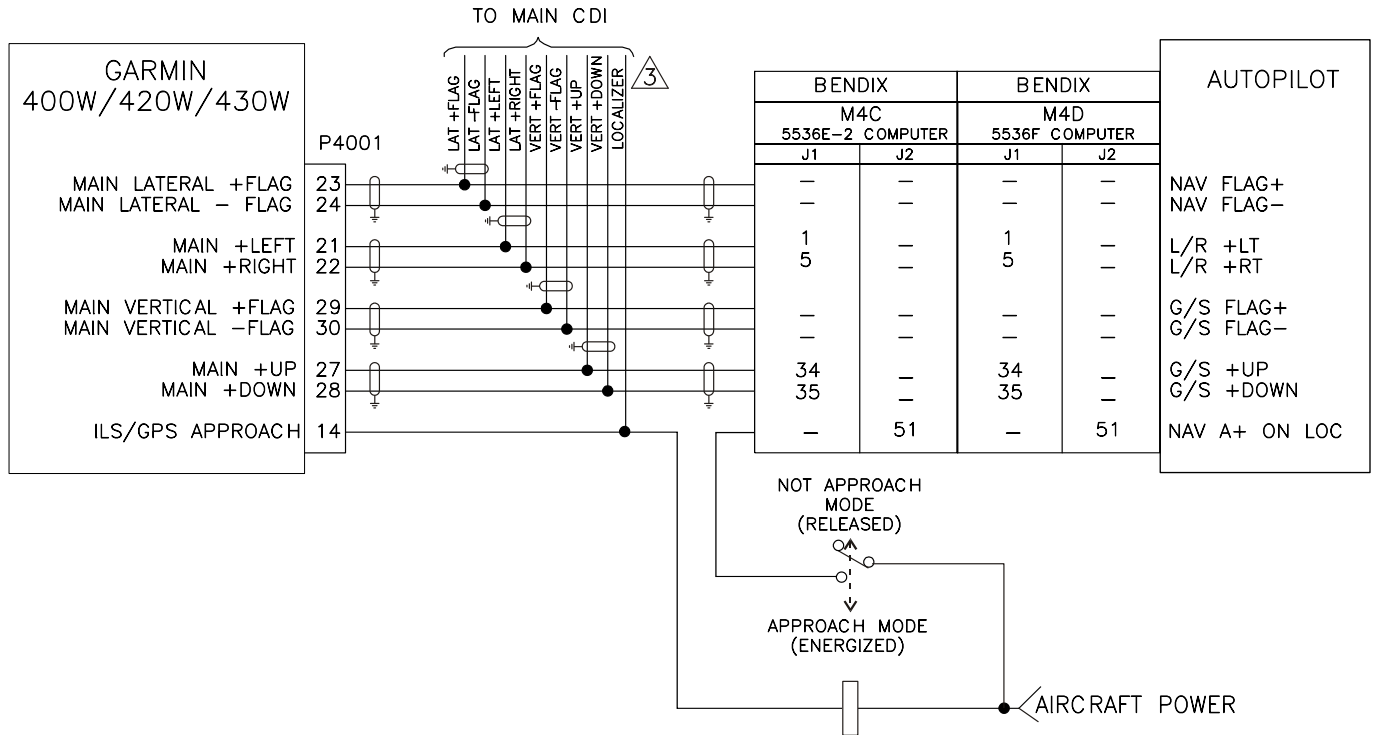

NOTES:

1. ALL WIRES 24 AWG OR LARGER UNLESS OTHERWISE SPECIFIED
 2. GNS 400W SERIES UNIT SETUP ITEMS
MAIN SYSTEM CONFIG PAGE: DISCRETES – GPS SELECT: AUTO
- ⚠ THE ILS/GPS APPROACH DISCRETE IS REQUIRED BY SOME CDIs/HSIs THAT ARE USED WITH THE M4C/D AUTOPILOTS. IF REQUIRED, ENSURE THAT THE SIGNAL SUPPLIED TO THE INDICATOR IS THE CORRECT POLARITY (ACTIVE-HIGH OR ACTIVE-LOW).

Figure H-32. Bendix Autopilot Interconnect

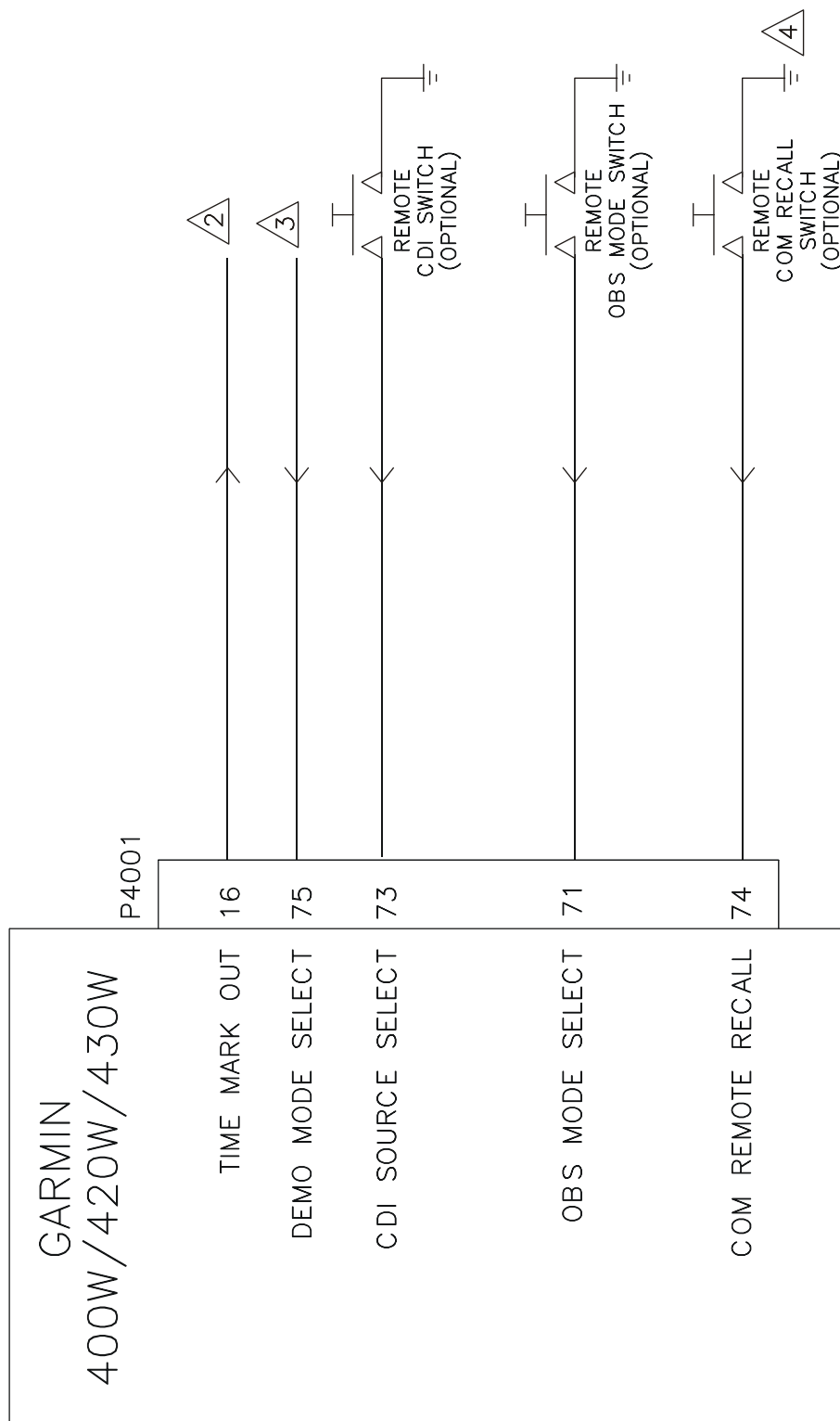

NOTES:

- 1 ALL WIRES 24 AWG OR LARGER UNLESS OTHERWISE SPECIFIED.
- 2 TIME MARK OUT (P4001-16) OUTPUTS A 1 MILLISECOND WIDE PULSE ONCE PER SECOND.
- 3 DEMO MODE SELECT (P4001-75) MAY BE GROUNDED TO START THE UNIT IN DEMO MODE. DO NOT USE IN AN AIRCRAFT INSTALLATION.
- 4 COM REMOTE RECALL (P4001-74) INPUT MAY BE USED TO SCROLL THROUGH A LIST OF PRESET COM FREQUENCIES. REFER TO 5.3.3 FOR CONFIGURATION INFORMATION.

Figure H-33. Switches Interconnect

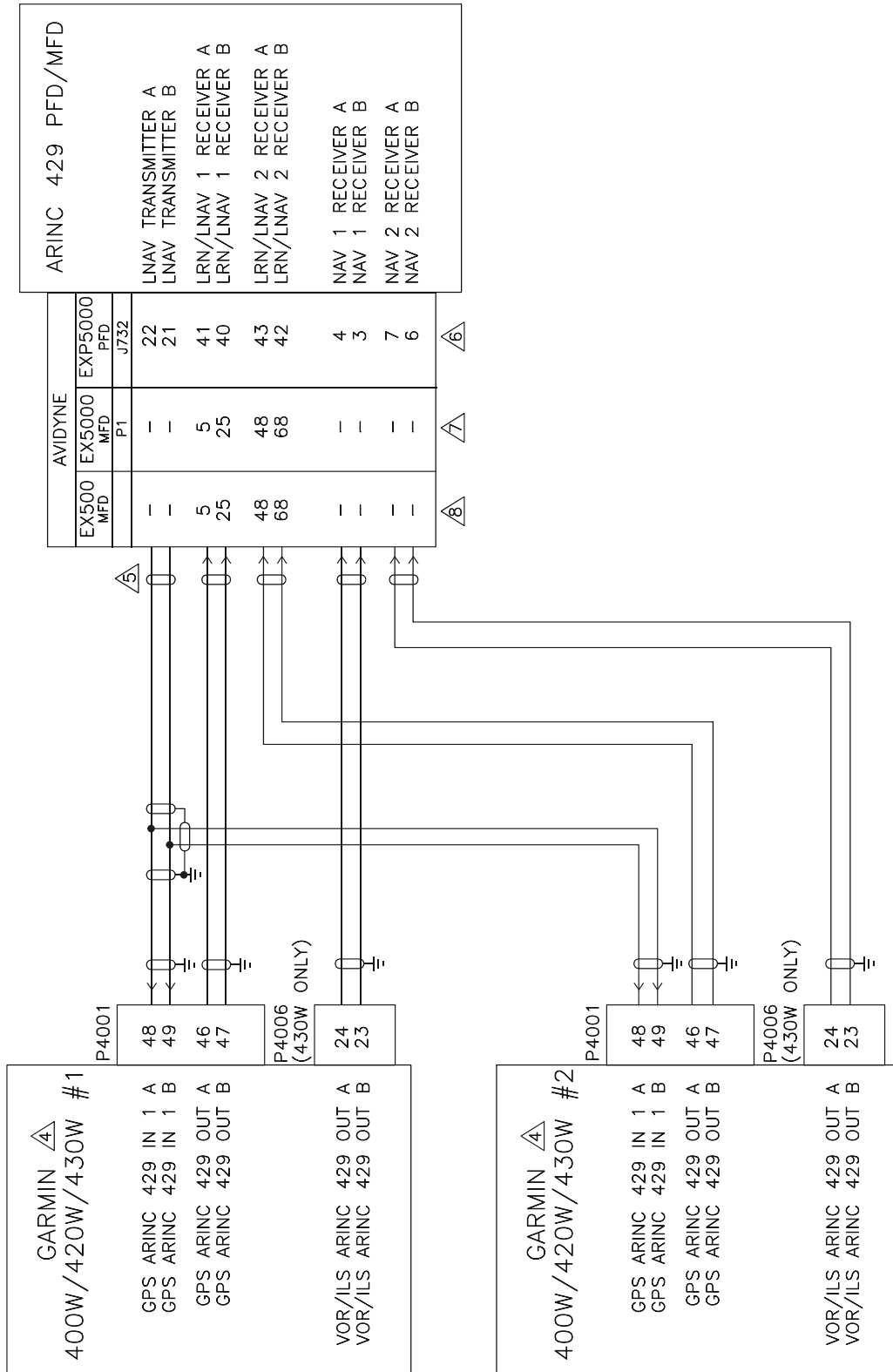

Figure H-34. ARINC 429 Avidyne PFD/MFD Interconnect
Sheet 1 of 2

NOTES:

1. ALL WIRES 24 AWG OR LARGER UNLESS OTHERWISE SPECIFIED.
2. AT GNS 400W SERIES UNIT, TERMINATE SHIELD GROUNDS TO THE CONNECTOR BACKSHELL OR USE CARD-EDGE CONNECTOR TO TERMINATE SHIELD GROUNDS TO BACK PLATE – THE SHIELD LEADS MUST BE LESS THAN 3.0 INCHES. CONNECT OTHER SHIELD GROUNDS TO AIRCRAFT CHASSIS WITH AS SHORT A CONDUCTOR AS PRACTICAL.
- ③ IF THE GPS ARINC 429 IN 1 PORT (P4001-48 AND -49) IS ALREADY USED FOR ANOTHER PURPOSE, THE GPS ARINC 429 IN 2 PORT (P4001-50 AND -51) MAY BE CONNECTED INSTEAD.
- ④ MAIN SOFTWARE VERSION 3.00 (OR LATER) IS REQUIRED FOR PROPER OPERATION WITH THE AVIDYNE UNITS.

GNS 430W #1 SETUP ITEMS:
MAIN ARINC 429 CONFIG:

IN 1: LOW, SANDEL EHSI
OUT: LOW, GAMA 429 GRAPHICS
SDI: LNAV 1
VNAV: ENABLE LABELS

VOR/LOC/GS ARINC 429 CONFIG:

SPEED RX: LOW TX: LOW
SDI: VOR/ILS 1

GNS 430W #2 SETUP ITEMS:
MAIN ARINC 429 CONFIG:

IN 1: LOW, SANDEL EHSI
OUT: LOW, GAMA 429 GRAPHICS
SDI: LNAV 2
VNAV: ENABLE LABELS

VOR/LOC/GS ARINC 429 CONFIG:

SPEED RX: LOW TX: LOW
SDI: VOR/ILS 2

- ⑤ TERMINATE SHIELDS AT PFD/MFD IN ACCORDANCE WITH MANUFACTURER'S DOCUMENTATION.
- ⑥ DISPLAY P/N 700-00006-() WITH SOFTWARE P/N 530-00194-() (OR LATER) IS REQUIRED FOR PROPER OPERATION WITH THE GNS 400W SERIES UNIT.

EXP5000 PFD SETUP ITEMS: GPS 1: GARMIN 430/530 ON ARINC 1
GPS 2: GARMIN 430/530 ON ARINC 3
VHF 1: GARMIN 430/530 ON ARINC 2
VHF 2: GARMIN 430/530 ON ARINC 4

- ⑦ DISPLAY P/N 700-00004-() OR 700-00030-() WITH SOFTWARE P/N 530-00195-() (OR LATER) IS REQUIRED FOR PROPER OPERATION WITH THE GNS 400W SERIES UNIT.

EX5000 MFD GPS/FMS SETUP ITEMS: RECEIVER 1: GAMA 429 FORMAT
PORT: ARINC 429 1
SPEED: LOW

RECEIVER 2: GAMA 429 FORMAT
PORT: ARINC 429 4
SPEED: LOW

- ⑧ DISPLAY P/N 700-00007-() WITH SOFTWARE P/N 530-00193-() (OR LATER) IS REQUIRED FOR PROPER OPERATION WITH THE GNS 400W SERIES UNIT.

EX500 MFD GPS/FMS SETUP ITEMS: RECEIVER 1: GAMA 429 FORMAT
PORT: ARINC 429 1
SPEED: LOW

RECEIVER 2: GAMA 429 FORMAT
PORT: ARINC 429 4
SPEED: LOW

9. REFER TO MANUFACTURER'S DOCUMENTATION FOR COMPLETE PINOUT AND INTERCONNECT INFORMATION. PINOUTS OF OTHER UNITS SHOWN FOR REFERENCE ONLY.
10. A 500W SERIES UNIT MAY BE USED IN PLACE OF EITHER #1 OR #2 400W SERIES UNIT. SEE THE 500W INSTALLATION MANUAL.

Figure H-34. ARINC 429 Avidyne PFD/MFD Interconnect
Sheet 2 of 2

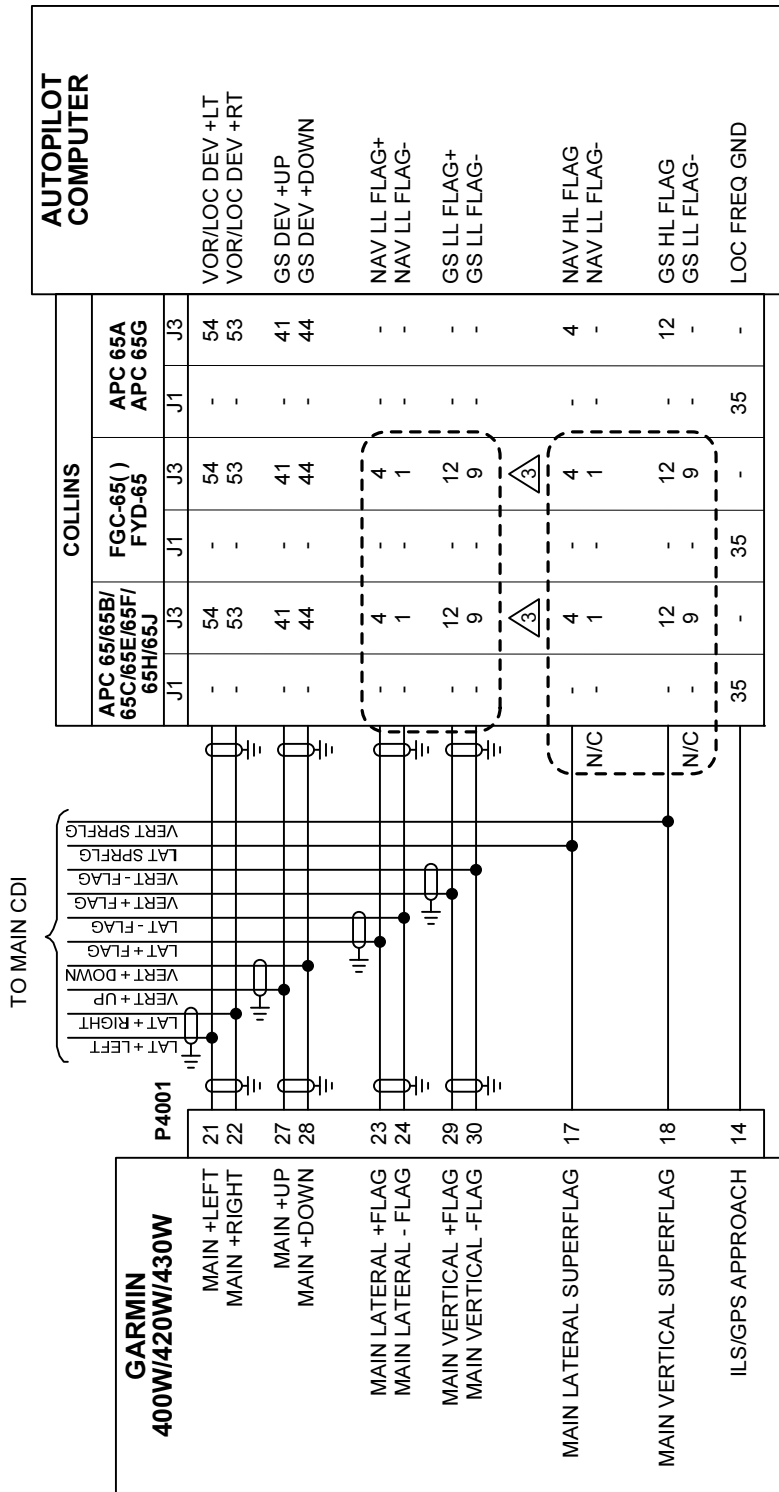

NOTES:

1. ALL WIRES 24 AWG OR LARGER UNLESS OTHERWISE SPECIFIED
 2. GNS 400W SETUP ITEMS
MAIN SYSTEM CONFIG PAGE: DISCRETES – GPS SELECT: AUTO
- ⚠️ CONNECT EITHER THE LOW-LEVEL FLAGS OR THE SUPERFLAGS. DO NOT CONNECT BOTH SETS OF FLAGS IN A PARTICULAR INSTALLATION.

Figure H-35. Collins Autopilot Interconnect

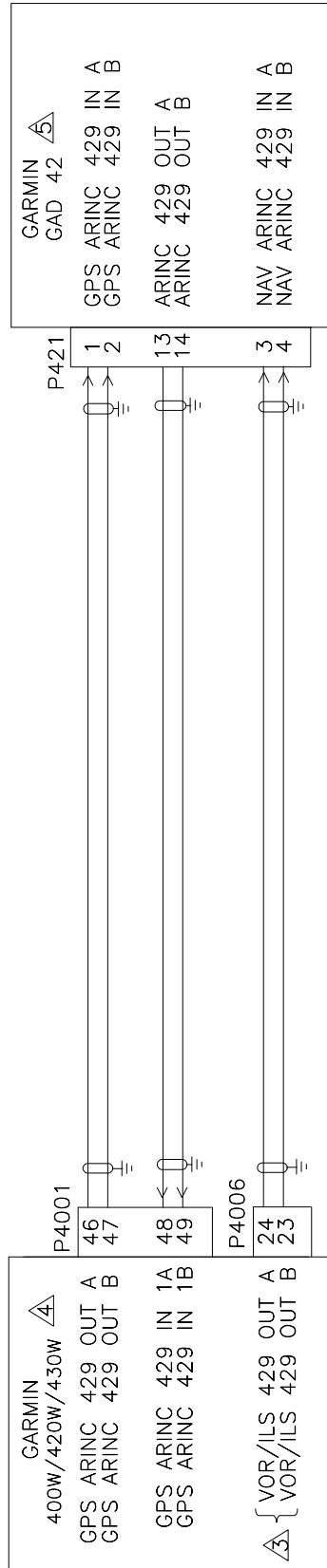

NOTES:

1. ALL WIRES 24 AWG OR LARGER UNLESS OTHERWISE SPECIFIED.
 2. AT GNS 400W SERIES UNIT, TERMINATE SHIELD GROUNDS TO THE CONNECTOR BACKSHELL OR USE CARD-EDGE CONNECTOR TO TERMINATE SHIELD GROUNDS TO BACK PLATE – THE SHIELD LEADS MUST BE LESS THAN 3.0 INCHES. CONNECT OTHER SHIELD GROUNDS TO AIRCRAFT CHASSIS WITH AS SHORT A CONDUCTOR AS PRACTICAL.
- ▲ FOR GNS 430W INSTALLATION ONLY.
 ▲ 400W SERIES SETUP ITEMS:
 MAIN ARINC 429 CONFIG: IN 1: LOW, GARMIN GAD 42
 OUT: ANY SPEED, ANY SETTING
- ▲ SEE GARMIN GAD 42 INSTALLATION MANUAL FOR COMPLETE PIN-OUT AND INTERCONNECTION INFORMATION. CONFIGURE THE GPS ARINC 429 BUS SPEED TO MATCH THE 400W SERIES OUTPUT SPEED.

Figure H-36. Garmin GAD 42 Interconnect

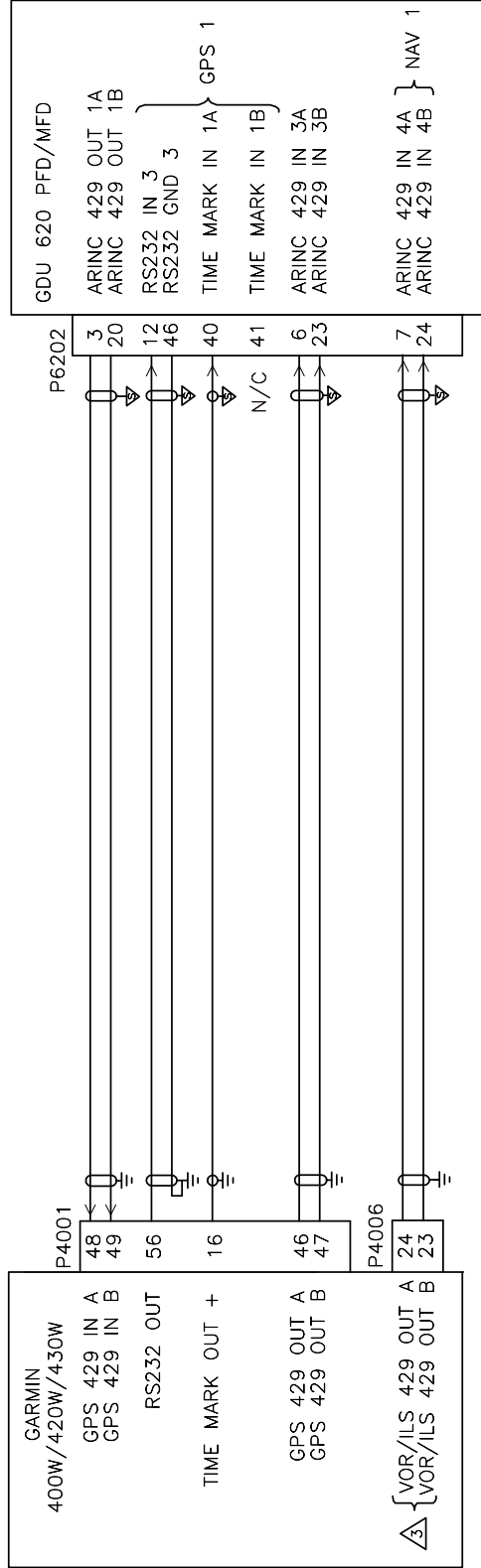

NOTES:

1. ALL WIRES 24 AWG OR LARGER UNLESS OTHERWISE SPECIFIED.
2. AT THE GNS 400W SERIES UNIT, TERMINATE SHIELD GROUNDS TO THE CONNECTOR BACKSHELL OR USE CARD-EDGE CONNECTOR TO TERMINATE SHIELD GROUNDS TO BACK PLATE – THE SHIELD LEADS MUST BE LESS THAN 3.0 INCHES. AT GDU 620, TERMINATE SHIELD GROUNDS USING SHIELD BLOCKS.
- ⚠ FOR GNS 430W INSTALLATION ONLY.
4. REFER TO THE MANUFACTURER'S DOCUMENTATION FOR COMPLETE PIN-OUT AND INTERCONNECT INFORMATION. PIN-OUTS OF OTHER UNITS SHOWN FOR REFERENCE ONLY.
5. FOR PROPER SETUP TO INTERFACE WITH THE G600, REFER TO THE G600 INSTALLATION MANUAL, APPENDIX E (P/N 190-00601-06).
6. FOR OTHER CONNECTION OPTIONS REFER TO THE G600 INSTALLATION MANUAL.

Figure H-37. Garmin G600 Interconnect

This page intentionally left blank

GARMIN[®]