

420D 420D IT

Backhoe Loader



Engine

Engine Model	Cat® 3054C DIT	
Gross Power (SAE J1995)	69 kW	93 hp
Net Power (SAE J1349)	66 kW	89 hp

Operating Weight

Nominal	7150 kg	15,772 lb
Maximum	9800 kg	21,605 lb

Backhoe

Dig Depth Standard	4390 mm	14 ft 5 in
Dig Depth Extended	5510 mm	18 ft 1 in

420D/420D IT Backhoe Loader

The 420D/420D IT Backhoe Loader sets the industry standard for operator comfort, exceptional performance and versatility.

Pilot Operated Joystick Controls

Standard pilot operated joystick controls add excavator technology and ease of operation to the 420D/420D IT. Low effort controls are easy to use, reduce operator fatigue and increase efficiency. **pg. 4**

Loader Performance

The standard loader and optional integrated toolcarrier offer versatile operation with increased breakout force and lift capacity. **pg. 5**

Backhoe Performance

- ✓ New standard Cat Cushion Swing system, industry leading rotation and forces, improved Diagonal Retention System, excavator-style boom and an optional extendible stick combine for high productivity levels while the new swing casting and valve improve performance and durability. **pg. 6**

Power Train

- ✓ New Cat 3054C DIT (Direct Injection Turbocharged) engine meets all EPA Tier 2/EU Stage II emissions requirements and is designed to deliver high productivity with higher net horsepower and an efficient fuel system that increases lug performance. **pg. 10**

Operator Station

The 420D/420D IT operator environment is ergonomically designed to create a comfortable work area with easy-to-use machine controls that reduce operator fatigue and increase efficiency and productivity. HVAC improvements increase operator comfort in all conditions. **pg. 12**

Additional Features

- ✓ Easy access flip-open hood, new color-coded fill caps and other benefits contribute to the ease of serviceability, efficiency and productivity of the 420D/420D IT. **pg. 14**

With higher horsepower, standard pilot-operated joystick controls, best-in-class bucket rotation, superb digging forces and overall backhoe lift, the 420D/420D IT is everything you expect from a Cat machine and more!



Buckets and Couplers

- ✓ An expansive bucket line, improved heavy-duty Diagonal Retention System and Quick Couplers increase productivity and versatility. **pg. 7**

Work Tools

A wide range of Caterpillar® Work Tools are available to meet the needs of your job site applications. **pg. 8**

Hydraulics

- ✓ Our state-of-the-art closed-center, variable displacement pump with enhancements to the load-sensing hydraulic system improve implement response and speed while still providing high forces at any engine speed. **pg. 9**

Customer Support

Your Cat dealer offers a wide range of services that help you operate longer with lower costs. **pg. 15**



✓ *New Feature*

Pilot Operated Joystick Controls

Low effort, comfortable controls reduce fatigue, increase the viewing area and give the operator more legroom.



Pilot Operated Stabilizer Controls.

These provide low effort and fine modulation control. The stabilizer controls are within easy reach of the operator when operating the backhoe.

Pilot Control Pods. Located on the left and right sides, the controls can move fore and aft and three stops are available for ergonomically correct positioning.

Joystick Controls. Standard excavator-style joysticks provide smooth modulation and are ergonomically designed for low effort control and operator comfort. As a result of this control design, legroom is increased and the rearward viewing area is greater.

Standard Pattern Changer Valve.

The hydraulic excavator control pattern is standard and switching between backhoe and excavator control patterns with the standard pattern changer valve is as easy as loosening and moving a bolt on the side of the machine.

Loader Performance

Single-tilt or integrated toolcarrier loaders offer solid performance and maximum versatility.

Loader Linkage. The standard single-tilt loader features increased lift and breakout forces. The optional integrated toolcarrier loader provides even higher forces, as well as parallel lift for efficient loading and material handling. A return-to-dig system makes operation easy and improves cycle times.



420D IT with Standard Quick Coupler

Quick Coupler. Provides versatility and allows quick connection to selected work tools for the Cat family of integrated toolcarriers. Most work tools can be changed in less than 30 seconds, from the comfort of the operator station.

Disconnects. Flat face hydraulic hose quick disconnect fittings with a connect-under-pressure feature improve the connection of hydraulic work tools.



IT Loader Controls. The 420D IT has a new, standard single lever, pilot-operated loader control for proportional control and fine modulation of the hydraulic work tools. A thumb roller control on top operates auxiliary hydraulic functions such as the clam bucket and two buttons control hydraulic broom angle.

Reverse Signal System. Pump control changes improve power management between the loader hydraulic system and machine rimpull for faster truck loading. The reverse signal system provides priority to backhoe hydraulics to maximize hydraulic horsepower.

Backhoe Performance

New Cat Cushion Swing system, high rotation linkage, improved Diagonal Retention System and strong dig forces boost productivity.



High Rotation Backhoe Linkage.

Single pin bucket linkage contributes to best-in-class rotation of 205 degrees for all applications, eliminating the need to change pin position when moving from loading trucks to vertical wall trenching.



Backhoe Boom. The excavator-style boom features box section fabrication with internal stiffeners for better balance and weight distribution. The curved design provides additional clearance over obstacles while digging a trench or truck loading. The narrow boom enhances the viewing area to the bucket and trench throughout the entire operating range.

Extendible Stick. This optional backhoe attachment replaces the standard stick and increases reach and dig depth by approximately 1.2 meters (4 feet). The extendible stick uses eight self-lubricated, non-metallic wear pads which can be shimmed or replaced. Durable wear pad materials increase wear life in all conditions.

New Cat Cushion Swing System.

The new, standard Cat Cushion Swing System smooths the backhoe swing function when returning to the trench.

New Backhoe Swing Casting.

Improved with replaceable bushings for durability and serviceability.

Buckets and Couplers

Our expansive bucket line and improved heavy-duty Diagonal Retention System contribute to increased durability and greater performance.



Heavy Duty Rock Bucket. Specifically designed to address harsh, rocky conditions and capable of digging in granite, caliche and rocky soil.



Bucket Characteristics. The side profile has a scalloped edge, similar to an excavator bucket, for exceptional fill factor characteristics and secure clamping ability.

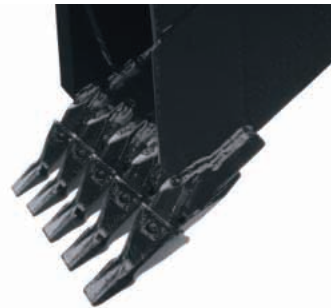

Quick Couplers. Allow for quick attachment of buckets and other work tools. The D-Series High Rotation pin grabber design and a C-Series compatible pin grabber allow buckets to be changed without removing the bucket pins. Other manufacturers' buckets can be coupled with a pin puller coupler, one for Case and D-Series buckets or one for John Deere and D-Series buckets. D-Series quick couplers are painted black for easy identification.

Bucket Line. Cat's expansive bucket line includes rock and coral bucket designs. All D-Series buckets are painted black and carry the Cat logo.

Standard Duty Bucket. Used in easy-to-penetrate, low-impact, moderately abrasive materials.

Heavy Duty Bucket. Used for a wide variety of soil conditions such as semi-rocky soil and hard bank material.

High Capacity Bucket. Same durable construction as the Heavy Duty bucket for tough materials but longer tip radius provides increased bucket capacity.

New DRS 230 (Diagonal Retention System). New DRS 230 with wide adapters provides maximum strength and improved wear characteristics. Heavy-duty bucket teeth are attached with diagonal pins rather than horizontal pins for easy exchange. The adapters are stronger as a result of this improved diagonal pinning and additional wear material on the bucket teeth increases durability.

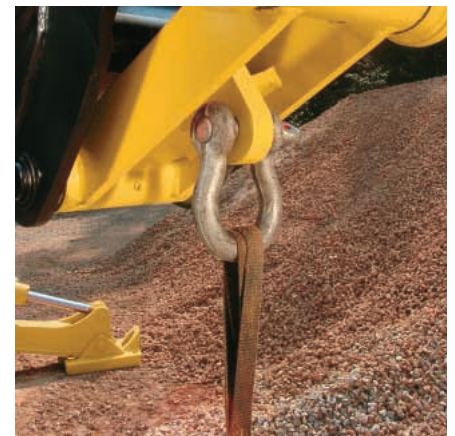

Lift Eye. An integral lifting eye is a standard feature of the bucket linkage.

Work Tools

Choose from a wide variety of tools designed specifically for the backhoe loader and integrated toolcarrier.

420D/420D IT Work Tools. Caterpillar Work Tools for backhoe loaders extend the versatility of the machine. Built for performance and durability, these tools deliver high productivity, long service life and excellent value:

Backhoe Work Tools

- Standard Duty Bucket
- Heavy Duty Bucket
- Heavy Duty Rock Bucket
- High Capacity Bucket
- Coral Bucket
- Ditch Cleaning Bucket
- Hydraulic Hammer
- Vibratory Plate Compactor
- Ripper
- Thumb
- Auger

Loader Work Tools

- General Purpose Bucket
- Multi Purpose Bucket
- Side Dump Bucket
- Light Material Bucket
- Penetration Bucket
- Loader Forks
- Material Handling Arm
- Angle Blade
- Broom
- Rake
- Asphalt Cutter
- Bale Spear
- Snow Plow



Hydraulics

Our state-of-the-art closed-center, variable displacement pump with enhancements to the load-sensing hydraulic system improves implement response and speed while still providing high forces at any engine speed.

Hydraulic System. The load-sensing, variable flow hydraulic system senses work demand and adjusts flow and pressure to match. This allows full hydraulic forces at any engine speed for delicate jobs in tight areas.

Hydraulic Pump. Closed-centered implement valves, with pressure compensation for reduced lever effort, signal hydraulic system requirements to a control valve located on the pump. This valve controls the pump to deliver the flow and pressure necessary to fulfill the implement demands.

Dual Setting Torque Limiter. The variable displacement pump provides better performance in both backhoe and loader operations through a dual setting torque limiter. It automatically optimizes power to the hydraulic system during backhoe operations and manages the power balance between the loader hydraulic circuit and the drive train during front loader operations.

XT-3 ES Hoses. Improved bend radius and abrasion resistance provide reliable long life in the toughest conditions. Made of four overlapping, insulated wire spiral wraps bonded together for durability, XT-3 ES (Enhanced Spiral) hoses exceed SAE certification standards. The hose routing protects them from work damage, and hose failure downtime is substantially reduced. XT-3 ES hoses combined with Caterpillar couplings and O-ring face seal fittings provide a leak-free system.



Clamps and Bushings. Metal clamps with rubber bushings are used at hose attachment points to eliminate metal-to-metal contact and increase wear life.

Power Train

New Cat 3054C DIT engine delivers higher net horsepower and increased lug performance for high productivity and efficiency.



Air Cleaner. A new, dry-type, axial seal air cleaner with automatic, integrated dust ejection system provides more efficient pre-separation. The two-stage air filter incorporates both air cleaner and precleaner functions into a single unit mounted under the hood.

Transmission. The Caterpillar Power Shuttle transmission provides four speeds forward and reverse. Full synchromesh gears and hydraulically shifted forward and reverse shuttle clutches allow direction and travel speed to be changed on-the-go. A neutral start provision prevents starting while the shuttle is engaged.

3054C DIT Diesel Engine. New 3054C DIT (Direct Injection Turbocharged) meets all U.S. EPA Tier 2/EU Stage II emissions requirements and delivers higher horsepower, increased torque rise and reliable power with low emissions while providing excellent fuel economy with an efficient fuel system and traditional Caterpillar durability.

Direct Injection Fuel System. Individual unit fuel injectors deliver efficient and accurate fuel metering, reduced emissions, reliable power, high torque rise and responsive performance. A new water separator service indicator ensures the operator is reminded when service is necessary.

Automatic Shift Transmission.

The optional Auto-Shift transmission automatically matches gears with grade and load conditions. Manual mode gives full gear selection to the operator for operation as a Power Shift transmission.

Kick-down Switch/Transmission Neutralizer.

Located on the loader lever, the kick-down switch on Auto-Shift machines allows the operator to downshift through the gears to first. When this switch is depressed for more than one second, it serves as the transmission neutralizer to maintain engine and hydraulic speed when dumping into trucks.

Transmission Neutralizer. Standard on Power Shuttle machines, the hand-operated power disconnect provides easy, on-the-go shifting and full engine rpm for faster cycle times.

Ride Control Option. Offers a smooth ride in all conditions and reduces machine loping while roading. It also provides better material retention during load and carry operations while greatly increasing operator comfort. The system engages with the flip of a switch.

New Caterpillar Front Axles. New Cat heavy-duty front axles are developed specifically for demanding backhoe loader applications.

Rear Axles and New Brakes. Heavy-duty rear axle with self-adjusting inboard brakes, differential lock and final drives. New Kevlar brake discs extend service life, provide quieter braking and decrease stopping distance.

Two Wheel Drive. New tapered roller bearings improve kingpin alignment and provide more wear resistance to extend the life of the front axle and tires.

All Wheel Drive (AWD) Option. Heavy-duty front drive axle can be engaged at any time by activating the switch on the front console. The switch can be activated while the machine is stopped or moving, with or without load. AWD features outboard planetary gear final drives and improves mobility and loader performance in poor traction conditions.

Brake Mode Selector. The brake mode selector switch has three positions: two wheel drive, two wheel drive with all wheel braking and all wheel drive. Center position provides two wheel drive for better tire life while roading and engages the front axle when brakes are applied for improved braking performance.

Operator Station

Designed for maximum comfort, ease of operation and increased productivity.



420D IT Deluxe Cab

Operator Comfort. The 420D/420D IT operator station incorporates years of cab design innovations to maximize operator productivity. The pilot operated controls allow for more legroom and a spacious work environment.

ROPS Canopy. Includes air suspension vinyl seat, tilt steering wheel, 12-volt power supply, phone clip, left side storage space with a lockable compartment, drink holders and floor mats.

New ROPS Canopy Plus. Includes air suspension vinyl seat, tilt steering wheel, 12-volt power supply, front windshield and wiper/washer system, phone clip, left side storage space with a lockable compartment, drink holders and floor mats.

Standard Cab. Features an air suspension fabric seat, tilt steering wheel, 12-volt power adapter, left-side storage console with drink holders and a lockable compartment, phone clip, two doors and rear windows with opening glass and eight working lights. The cab is radio-ready.

Deluxe Cab. Includes all standard cab benefits plus a deluxe, nine-way adjustable air suspension seat; pilot operated stabilizer controls with individual auto-up feature; additional system monitoring including a voltmeter and service indicators for fuel water separator, engine air cleaner and hydraulic filters.

HVAC System. The heating, ventilation and air conditioning system main components are located near the floor and improvements have been made to air circulation and increased defrost capabilities. New air duct routings provide improved air flow to the operator.

Tilt Wheel. The standard tilt steering wheel on every 420D/420D IT allows more room when entering and exiting the cab and allows the operator to choose the most comfortable steering position.



Deluxe Seat

Air Suspension Seat. Utilizes an air adjustment mechanism for a greater operating range and more comfortable ride. By pressing a button, the seat can be tailored to support differing body weights. Adjustable seat height accommodates all operators. The Deluxe cab seat also has an adjustable back support, lumbar support, seat cushion extension, seat cushion tilt, as well as vertical and angle adjusting armrests.



Operator Controls. The controls of the 420D/420D IT have been carefully laid out to create a user-friendly environment. Switches, boom lock and pilot operated stabilizer controls are located in the side console, within easy reach of the operator. White-faced gauges are easy to read and the low effort pilot controls reduce operator fatigue and help boost overall productivity.

Ride Control System. Provides a smoother ride in all applications, reduces machine loping while roading and provides better material retention during load and carry operations while increasing operator comfort. A nitrogen accumulator added to the loader lift circuit cushions the system and engages with the flip of a switch.

Rear Window. The rear window features a heavy-duty hinge structure and positive latch mechanism to hold the window in the open position.

Additional Features

Easy access flip-open hood, new color-coded fill caps and other benefits contribute to the ease of serviceability, efficiency and productivity of the 420D/420D IT.



Color-coded fill caps

Flip-Open Hood. The flip-open hood provides easy, convenient access to all engine check points from the left side of the machine. Fill caps are color-coded for quick identification.

Stackable Counterweights. Allow easy adjustment of weight distribution without having to completely replace an existing counterweight.

Fuel Tank. Large capacity tank located on the frame's left side is lockable and includes a replaceable, bolt-on step.

Tool and Battery Box. Spacious, convenient and secure tool storage location.

Customer Support

Cat dealer services help you operate longer with lower costs.

Machine Selection. Make detailed comparisons of the machines under consideration before purchase. Cat dealers can estimate component life, preventative maintenance cost and the true cost of lost production. You can also customize the machine that is right for you. Go on-line anytime to review the full range of features and options available using the Build and Quote applications on your dealer's website or www.Cat.com.

Purchase. Look at the total package. Consider the financing options available as well as day-to-day operating costs. Look at dealer services that can be included in the cost of the machine to yield lower equipment owning and operating costs over the long run.

Customer Support Agreements. Cat dealers offer a variety of product support agreements and work with customers to develop a plan that best meets specific needs. These plans can cover the entire machine, including work tools, to help protect the customer's investment.

Product Support. You will find nearly all parts at our dealer parts counter. Cat dealers use a worldwide computer network to find in-stock parts to minimize machine downtime. Save money with genuine Cat Reman parts. You receive the same warranty and reliability as new products, but with a cost savings of 40 to 70 percent.

Operation. Improving operating techniques can boost your profits. Your Cat dealer has training videotapes, literature and other ideas to help you increase productivity.



Maintenance Services. Choose from your dealer's range of maintenance services when you purchase your machine. Repair option programs guarantee the cost of repairs up front. Diagnostic programs such as S•O•SSM and Coolant Sampling and Technical Analysis help you avoid unscheduled repairs.

Replacement. Repair, rebuild or replace? Your Cat dealer can help you evaluate the cost involved so you can make the right choice.

Engine

Engine Model	Cat 3054C DIT	
Gross Power (SAE J1995)	69 kW	93 hp
ISO 14396	69 kW	92 hp
Net Power (SAE J1349)	66 kW	89 hp
ISO 9249	67 kW	90 hp
EEC 80/1269	67 kW	90 hp
DIN 700200	96 PS	
Bore	105 mm	4.13 in
Stroke	127 mm	5 in
Displacement	4.4 L	268 in ³
Net Torque Rise @ 1400 rpm	32 %	
Net Peak Torque @ 1400 rpm	381 N•m	281 lb ft

- The net power ratings apply at 2200 rpm when tested under the specified conditions for the specified standard.
- Net Torque Rise meets SAE J1349.

Weights

Operating Weight		
Nominal	7150 kg	15,772 lb
Maximum	9800 kg	21,605 lb
Cab, ROPS/FOPS	234 kg	515 lb
Auto-Shift Transmission	25 kg	55 lb
Ride Control	25 kg	55 lb
Air Conditioning	45 kg	99 lb
All-Wheel Drive	106 kg	234 lb
MP Bucket 0.96 m ³ (1.25 yd ³)		
w/Fold-Over Fork	402 kg	886 lb
w/o Fold-Over Fork	231 kg	509 lb
Loader, IT w/QC	336 kg	741 lb
Extendible Stick (no weights)	255 kg	562 lb
Counterweights		
Base	145 kg	320 lb
Stack (3), each	104 kg	230 lb
Stack (1)	213 kg	470 lb

- Bumper (16 kg/35 lb) is standard with all units.
- Total gross machine weight not to exceed 9800 kg (21,605 lb).

Backhoe

Dig Depth		
Standard	4390 mm	14 ft 5 in
E-Stick Retracted	4465 mm	14 ft 8 in
E-Stick Extended	5510 mm	18 ft 1 in
Reach from Swing Pivot		
Standard	5650 mm	18 ft 6 in
E-Stick Retracted	5705 mm	18 ft 9 in
E-Stick Extended	6675 mm	21 ft 11 in
Bucket Rotation	205°	
Bucket Dig Force		
Standard	65.4 kN	14,712 lb
E-Stick Retracted	64.9 kN	14,586 lb
E-Stick Extended	64.9 kN	14,586 lb
Stick Dig Force		
Standard	38.2 kN	8,593 lb
E-Stick Retracted	37.5 kN	8,421 lb
E-Stick Extended	27.5 kN	6,188 lb
Stick Lift @ 1219 mm (4 ft)		
Standard	4780 kg	10,538 lb
E-Stick Retracted	4053 kg	8,936 lb
E-Stick Extended	1869 kg	4,121 lb
Loading Height	3613 mm	11 ft 10 in
Loading Reach	1732 mm	5 ft 8 in

Operating Specifications — Backhoe

Turning Circle: outside		
Front Wheels	8 m	26 ft 4 in
Widest Loader Bucket	10.8 m	35 ft 5 in

- ISO 5010.
- 2WD, AWD (inner wheel not braked).

Loader

Bucket Capacity — General Purpose	0.96 m ³	1.25 yd ³
Bucket Width — General Purpose	2262 mm	89 in
Dump Height @ Max Angle		
Single-tilt	2544 mm	8 ft 4 in
IT with QC	2462 mm	8 ft 1 in
Dump Reach @ Max Angle		
Single-tilt	835 mm	2 ft 9 in
IT with QC	862 mm	2 ft 10 in
Dig Depth		
Single-tilt	135 mm	5 in
IT with QC	135 mm	5 in
Lift Capacity @ Full Height		
Single-tilt	2896 kg	6,385 lb
IT with QC	3162 kg	6,970 lb
Bucket Breakout Force		
Single-tilt	45.1 kN	10,131 lb
IT with QC	47 kN	10,564 lb

Hydraulic System

Circuit Type	Closed Center	
Pump Capacity (@ 2200 rpm)	163 L/min	43 gal/min
System Pressure	22 754 kPa	3,300 psi
Pump Type	Variable flow, axial-piston	
Steering Type	Front wheel	
Power Steering	Hydrostatic	
2WD Cylinder		
Bore	70 mm	2.75 in
Stroke	224 mm	8.8 in
Rod Dia.	44 mm	1.75 in
AWD Cylinder		
Bore	65 mm	2.56 in
Stroke	311 mm	8.3 in
Rod Dia.	36 mm	1.42 in
Brake System	Inboard, oil-immersed	

Brakes

- Brakes meet SAE J1473 and ISO 3450 requirements.
- Inboard, oil-immersed, hydraulically actuated, multiple discs on final drive input shaft.
- Self-adjusting, completely enclosed and sealed.
- Foot operated brake pedals can be interlocked for roading.
- Parking/secondary brakes are independent of the service brake system. Parking brake is mechanically applied through an adjustable hand lever located on the right console.

Power Train

Power-Shuttle, Forward 1st	5.8 kph	3.6 mph
Forward 2nd	9.3 kph	5.8 mph
Forward 3rd	19.2 kph	12 mph
Forward 4th	32.8 kph	20.4 mph
Power-Shuttle, Reverse 1st	5.8 kph	3.6 mph
Reverse 2nd	9.3 kph	5.8 mph
Reverse 3rd	19.2 kph	12 mph
Reverse 4th	32.8 kph	20.4 mph
Auto-Shift (opt), Forward 1st	5.7 kph	3.5 mph
Forward 2nd	9.2 kph	5.7 mph
Forward 3rd	12.3 kph	7.6 mph
Forward 4th	19 kph	11.9 mph
Forward 5th	32 kph	20 mph
Auto-Shift (opt), Reverse 1st	5.7 kph	3.5 mph
Reverse 2nd	12.3 kph	7.6 mph
Reverse 3rd	23 kph	14.5 mph

- Auto-Shift automatically shifts between second gear and highest selected gear.
- Forward/reverse electric power shuttle is controlled by a conveniently placed, hand operated lever that provides instant direction changes between forward and reverse through power hydraulic clutches.
- Torque converter free-wheel clutch allows the converter stator to free-wheel during high speed, low torque conditions such as roading.
- Single-stage, 2.63:1 stall ratio.
- Travel speeds of two wheel drive backhoe loader at full throttle when equipped with 19.5 × 24 rear tires.

Service Refills

Cooling System		
A/C	15.9 L	4.2 gal
High-Ambient	18.7 L	4.4 gal
Fuel Tank	128.7 L	34 gal
Engine Oil w/Filter	7.6 L	2 gal
Transmission		
2WD, Power Shuttle	15.1 L	4 gal
AWD, Power Shuttle	18.2 L	4.8 gal
2WD, Auto Shift	15.1 L	4 gal
AWD, Auto Shift	15.1 L	4 gal
Rear Axle	24.2 L	6.4 gal
Front Axle		
AWD	7.6 L	2 gal
Planetaries	0.8 L	0.2 gal
Hydraulic System	79 L	21 gal
Hydraulic Tank	38 L	10 gal

Axle Ratings

Front Axle

2WD

Static	13 765 kg	30,319 lb
Dynamic	3170 kg	6,983 lb

AWD

Static	12 271 kg	27,029 lb
Dynamic	3170 kg	6,983 lb

Rear Axle

Static	27 800 kg	61,233 lb
Dynamic	20 418 kg	9,270 lb

- AWD and 2WD axles are pendulum mounted and permanently sealed and lubricated, requiring no daily maintenance. Also features double-acting steering cylinder with 50° steering angle for increased maneuverability. Oscillation 11° each direction from centerline.

Standards

Brakes SAE J1473, ISO 3450

Cab

ROPS SAE J1040 MAY 94 and ISO 3471:1994

FOPS SAE J/ISO 3449 APR98 LEVEL II and ISO 3449:1992 LEVEL II

Sound ANSI/SAE J1166

Sound SAE J88

- When properly installed and maintained, the enclosed cab offered by Caterpillar meets all OSHA and MSHA requirements for operator sound exposure limits in effect at the time of manufacture. When tested with doors and windows closed and measured according to ANSI/SAE J1166, the operator sound exposure Leq (equivalent sound pressure level) is 78.5 dB(A).

Engine Power Rating Conditions

- Based on standard air conditions of 25° C (77° F) and 99 kPa (29.32 in) in dry barometer.
- Used 35° API gravity fuel having an LHV of 42,780 kJg (18,390 BTU/lb) when used at 30° C (89° F) (reference a fuel density of 838.9 g/L [7.001 lb/gal]).
- Net power advertised is the power available at the flywheel when the engine is equipped with fan, air cleaner, muffler and alternator.
- No derating required up to 2286 m (7500 ft).

Engine Features

- Dry-type, axial seal air cleaner with automatic, integrated dust ejection system provides more efficient pre-separation. Rolled air filters allow consistent linear flow with reduced installation space.
- Three-ring pistons made of lightweight, silicon/aluminum alloy for strength and maximum thermal conductivity.
- Forged chrome/molybdenum-steel crankshaft with crankshaft with either induction hardened or nitro-carburized journals.
- Front and rear crankshaft oil seals are “lip” type Viton and PTFE designs featuring an integral dust lip.
- Heat resistant, silicone-chrome steel intake and STELLITE-faced exhaust valves provide long life.
- Cylinder block is high strength, cast iron alloy of deep skirt, monobloc design for increased strength and long life.
- Cylinder head is high strength, cast iron alloy construction with extra duty wall and deck thickness. Intake and exhaust ports are precision cast to promote optimum gas flow.
- Direct injection fuel system provides accurate fuel delivery and remote mounted electric lift pump improves serviceability.
- Self-priming electric lift pump for improved cold start capability and easy filter changes.
- One filter fuel system reduces owning & operating costs.
- Direct electric, 12-volt starting and charging system with 880 CCA Group 31 maintenance free battery.
- Standard glow plug starting aid system for efficient cold weather starting.
- High contact ratio/gear train, peripheral fixed isolated top cover and open deck block design reduce bare engine noise.
- Higher low end torque for better engine/machine performance.

Tires

Tubeless, nylon, loader-design tire sets.

Type	Size	Ply Rating
2WD Bias		
Front	11L x 16	12
Rear	19.5 x 24	10
4WD Bias		
Front	12.5/80 x 18	10
Rear	19.5 x 24	10
4WD Radial		
Front	340/80 x R18	radial
Rear	19.5 x 24	radial
4WD Combination		
Front	340/80 x R18	radial
Rear	19.5 x 24	10

Standard Duty Buckets

With weld-on adapters and pin-on teeth.

Width (mm/in)	Capacities SAE (liters/ft ³)	Weight (kg/lb)	No. of Teeth
305/12	78/2.8	97/213	3
457/18	118/4.2	115/253	4
610/24	175/6.2	132/290	5
762/30	233/8.2	147/323	5
914/36	292/10.3	165/363	6

High Capacity Buckets

With weld-on adapters and pin-on teeth.

Width (mm/in)	Capacities SAE (liters/ft ³)	Weight (kg/lb)	No. of Teeth
457/18	180/6.4	146/321	4
610/24	240/8.5	171/376	5
762/30	320/11.3	195/429	5
914/36	380/13.4	214/471	6

Heavy Duty Buckets

With weld-on adapters and pin-on teeth.

Width (mm/in)	Capacities SAE (liters/ft ³)	Weight (kg/lb)	No. of Teeth
305/12	78/2.8	105/231	3
406/16	105/3.7	127/279	3
457/18	118/4.2	129/284	4
610/24	175/6.2	151/332	5
762/30	233/8.2	167/367	5
914/36	292/10.3	189/416	6

Heavy Duty Rock Buckets

With weld-on adapters and pin-on teeth.

Width (mm/in)	Capacities SAE (liters/ft ³)	Weight (kg/lb)	No. of Teeth
305/12	70/2.5	120/265	3
457/18	127/4.5	150/331	4
610/24	198/7.0	175/386	5
762/30	255/9.5	195/430	5
914/36	311/11.5	210/463	6

Counterweights

Minimum Counterweight Recommendations — Standard Stick

Loader Bucket	Power Train	Single-Tilt		IT Loader w/QC	
		kg	lb	kg	lb
GP	2WD	355	780	bumper	bumper
GP	AWD	250	550	bumper	bumper
MP	2WD/AWD	bumper	bumper	bumper	bumper
MP with fold-over forks	2WD/AWD	bumper	bumper	N/A	N/A
Forks	2WD/AWD	N/A	N/A	bumper	bumper
Material handling arm	2WD/AWD	N/A	N/A	145	320

Minimum Counterweight Recommendations — Extendible Stick

Loader Bucket	Power Train	Single-Tilt		IT Loader w/QC	
		kg	lb	kg	lb
GP	2WD	570	1,250	354	780
GP	AWD	570	1,250	250	550
MP	2WD	250	550	bumper	bumper
MP	AWD	145	320	bumper	bumper
MP with fold-over forks	2WD	bumper	bumper	N/A	N/A
MP with fold-over forks	AWD	bumper	bumper	N/A	N/A
Forks	2WD	N/A	N/A	250	550
Forks	AWD	N/A	N/A	145	320
Material handling arm	2WD	N/A	N/A	570	1,250
Material handling arm	AWD	N/A	N/A	460	1,010

Machine Dimensions

	Single-Tilt Loader		
	General Purpose (0.96 m ³ /1.25 yd ³)	General Purpose (1.00 m ³ /1.31 yd ³)	General Purpose (1.07 m ³ /1.40 yd ³)
(1) Overall transport length	7019 mm/23 ft 0 in	6989 mm/22 ft 11 in	7052 mm/23 ft 2 in
Overall length (loader on ground)	6999 mm/23 ft 0 in	6954 mm/22 ft 10 in	7015 mm/23 ft 0 in
(2) Overall transport height (standard stick)	3585 mm/11 ft 9 in	3585 mm/11 ft 9 in	3585 mm/11 ft 9 in
Overall transport height (extendible stick)	3590 mm/11 ft 9 in	3590 mm/11 ft 9 in	3590 mm/11 ft 9 in
Overall width	2352 mm/7 ft 9 in	2352 mm/7 ft 9 in	2352 mm/7 ft 9 in
(3) Height to top of cab/canopy	2770 mm/9 ft 1 in	2770 mm/9 ft 1 in	2770 mm/9 ft 1 in
(4) Height to top of exhaust stack	2670 mm/8 ft 9 in	2670 mm/8 ft 9 in	2670 mm/8 ft 9 in
Height to loader hinge pin (transport)	510 mm/1 ft 8 in	510 mm/1 ft 8 in	510 mm/1 ft 8 in
Ground clearance (minimum)	297 mm/1 ft 0 in	297 mm/1 ft 0 in	297 mm/1 ft 0 in
(5) Rear axle centerline to front grill	2660 mm/8 ft 9 in	2660 mm/8 ft 9 in	2660 mm/8 ft 9 in
Front wheel tread gauge	1871 mm/6 ft 2 in	1871 mm/6 ft 2 in	1871 mm/6 ft 2 in
Rear wheel tread gauge	1714 mm/5 ft 8 in	1714 mm/5 ft 8 in	1714 mm/5 ft 8 in
(6) Wheelbase 2WD/AWD	2100 mm/6 ft 11 in	2100 mm/6 ft 11 in	2100 mm/6 ft 11 in

	Single-Tilt Loader	
	Multi Purpose (0.96 m ³ /1.25 yd ³)	Multi Purpose (1.03 m ³ /1.35 yd ³)
(1) Overall transport length	6974 mm/22 ft 11 in	6974 mm/22 ft 11 in
Overall length (loader on ground)	6954 mm/22 ft 10 in	6954 mm/22 ft 10 in
(2) Overall transport height (standard stick)	3585 mm/11 ft 9 in	3585 mm/11 ft 9 in
Overall transport height (extendible stick)	3590 mm/11 ft 9 in	3590 mm/11 ft 9 in
Overall width	2352 mm/7 ft 9 in	2352 mm/7 ft 9 in
(3) Height to top of cab/canopy	2770 mm/9 ft 1 in	2770 mm/9 ft 1 in
(4) Height to top of exhaust stack	2670 mm/8 ft 9 in	2670 mm/8 ft 9 in
Height to loader hinge pin (transport)	510 mm/1 ft 8 in	510 mm/1 ft 8 in
Ground clearance (minimum)	297 mm/1 ft 0 in	297 mm/1 ft 0 in
(5) Rear axle centerline to front grill	2660 mm/8 ft 9 in	2660 mm/8 ft 9 in
Front wheel tread gauge	1871 mm/6 ft 2 in	1871 mm/6 ft 2 in
Rear wheel tread gauge	1714 mm/5 ft 8 in	1714 mm/5 ft 8 in
(6) Wheelbase 2WD/AWD	2100 mm/6 ft 11 in	2100 mm/6 ft 11 in

IT Loader with Quick Coupler

	General Purpose (0.96 m ³ /1.25 yd ³)	General Purpose (1.00 m ³ /1.31 yd ³)	Multi Purpose (0.96 m ³ /1.25 yd ³)	Multi Purpose (1.03 m ³ /1.35 yd ³)
(1) Overall transport length	7064 mm/23 ft 2 in	7034 mm/23 ft 1 in	7014 mm/23 ft 0 in	7014 mm/23 ft 0 in
Overall length (loader on ground)	7044 mm/23 ft 1 in	6998 mm/23 ft 0 in	6994 mm/22 ft 11 in	6994 mm/22 ft 11 in
(2) Overall transport height (standard stick)	3585 mm/11 ft 9 in	3585 mm/11 ft 9 in	3585 mm/11 ft 9 in	3585 mm/11 ft 9 in
Overall transport height (extendible stick)	3590 mm/11 ft 9 in	3590 mm/11 ft 9 in	3590 mm/11 ft 9 in	3590 mm/11 ft 9 in
Overall width	2352 mm/7 ft 9 in	2352 mm/7 ft 9 in	2352 mm/7 ft 9 in	2352 mm/7 ft 9 in
(3) Height to top of cab/canopy	2770 mm/9 ft 1 in	2770 mm/9 ft 1 in	2770 mm/9 ft 1 in	2770 mm/9 ft 1 in
(4) Height to top of exhaust stack	2670 mm/8 ft 9 in	2670 mm/8 ft 9 in	2670 mm/8 ft 9 in	2670 mm/8 ft 9 in
Height to loader hinge pin (transport)	510 mm/1 ft 8 in	510 mm/1 ft 8 in	510 mm/1 ft 8 in	510 mm/1 ft 8 in
Ground clearance (minimum)	297 mm/1 ft 0 in	297 mm/1 ft 0 in	297 mm/1 ft 0 in	297 mm/1 ft 0 in
(5) Rear axle centerline to front grill	2660 mm/8 ft 9 in	2660 mm/8 ft 9 in	2660 mm/8 ft 9 in	2660 mm/8 ft 9 in
Front wheel tread gauge	1871 mm/6 ft 2 in	1871 mm/6 ft 2 in	1871 mm/6 ft 2 in	1871 mm/6 ft 2 in
Rear wheel tread gauge	1714 mm/5 ft 8 in	1714 mm/5 ft 8 in	1714 mm/5 ft 8 in	1714 mm/5 ft 8 in
(6) Wheelbase 2WD/AWD	2100 mm/6 ft 11 in	2100 mm/6 ft 11 in	2100 mm/6 ft 11 in	2100 mm/6 ft 11 in

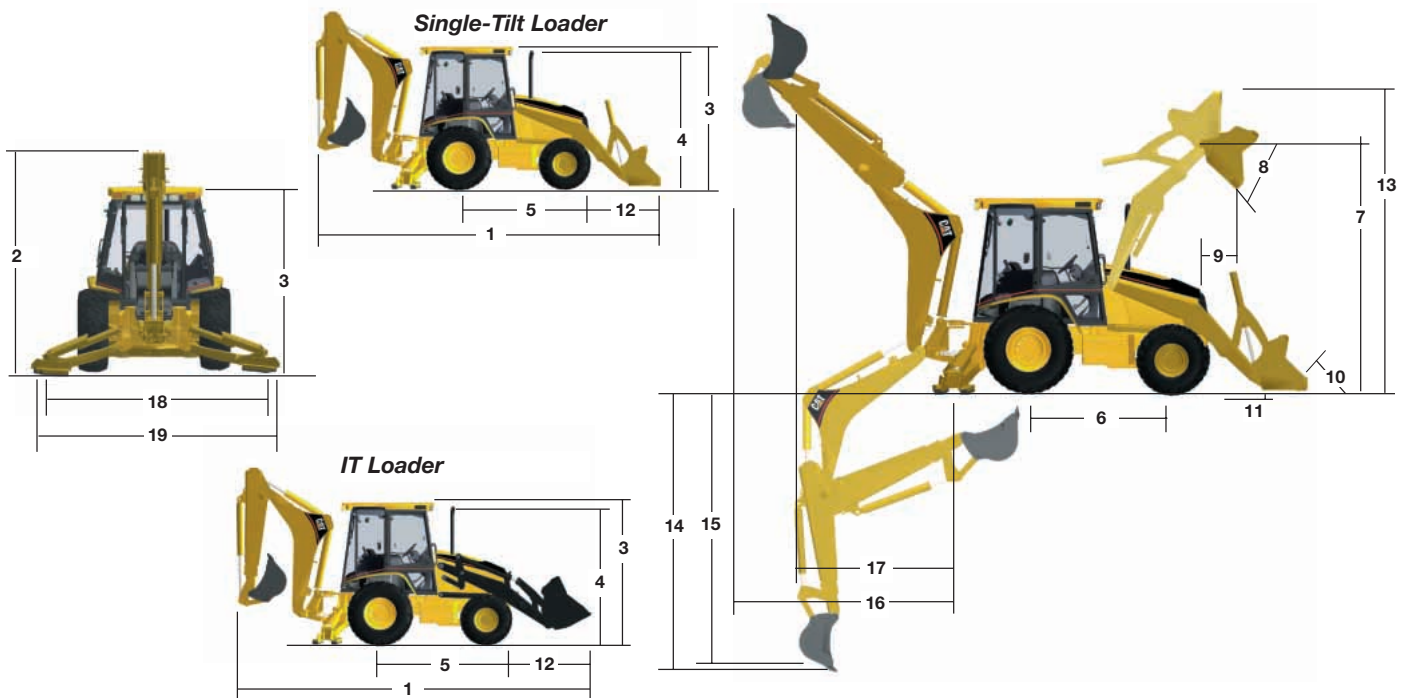

Loader Bucket Dimensions and Performance

Single-Tilt Loader

	General Purpose (0.96 m ³ /1.25 yd ³)	General Purpose (1.00 m ³ /1.31 yd ³)	General Purpose (1.07 m ³ /1.40 yd ³)
Capacity (SAE) rated	0.96 m ³ /1.25 yd ³	1.00 m ³ /1.31 yd ³	1.07 m ³ /1.40 yd ³
Width	2262 mm/7 ft 5 in	2406 mm/7 ft 11 in	2262 mm/7 ft 5 in
Lift capacity at maximum height	2896 kg/6,385 lb	2898 kg/6,391 lb	2837 kg/6,254 lb
Breakout force	45.1 kN/10,131 lb	45.7 kN/10,269 lb	44.6 kN/10,026 lb
(7) Maximum hinge pin height	3266 mm/10 ft 9 in	3266 mm/10 ft 9 in	3266 mm/10 ft 9 in
(8) Dump angle at full height	43°	43°	43°
Dump height at maximum angle	2544 mm/8 ft 4 in	2575 mm/8 ft 5 in	2521 mm/8 ft 3 in
(9) Dump reach at maximum angle	835 mm/2 ft 9 in	802 mm/2 ft 8 in	801 mm/2 ft 8 in
(10) Maximum bucket rollback at ground level	40°	40°	40°
(11) Digging depth	135 mm/5 in	135 mm/5 in	174 mm/7 in
Maximum grading angle	106°	107°	107°
Width of dozer cutting edge	N/A	N/A	N/A
(12) Grill to bucket cutting edge, carry position	1548 mm/5 ft 1 in	1519 mm/5 ft 0 in	1581 mm/5 ft 2 in
(13) Maximum operating height	4146 mm/13 ft 7 in	4146 mm/13 ft 7 in	4188 mm/13 ft 9 in
Jaw opening maximum	N/A	N/A	N/A
Bucket jaw clamping force	N/A	N/A	N/A
Weight (does not include teeth or forks)	431 kg/950 lb	445 kg/980 lb	438 kg/965 lb

Single-Tilt Loader

	Multi Purpose (0.96 m ³ /1.25 yd ³)	Multi Purpose (1.03 m ³ /1.35 yd ³)
Capacity (SAE) rated	0.96 m ³ /1.25 yd ³	1.03 m ³ /1.35 yd ³
Width	2262 mm/7 ft 5 in	2406 mm/7 ft 11 in
Lift capacity at maximum height	2747 kg/6,056 lb	2707 kg/5,968 lb
Breakout force	44.9 kN/10,099 lb	44.6 kN/10,018 lb
(7) Maximum hinge pin height	3266 mm/10 ft 9 in	3266 mm/10 ft 9 in
(8) Dump angle at full height	43°	43°
Dump height at maximum angle	2609 mm/8 ft 7 in	2609 mm/8 ft 7 in
(9) Dump reach at maximum angle	721 mm/2 ft 4 in	721 mm/2 ft 4 in
(10) Maximum bucket rollback at ground level	40°	40°
(11) Digging depth	165 mm/6.5 in	165 mm/6.5 in
Maximum grading angle	110°	110°
Width of dozer cutting edge	2406 mm/7 ft 11 in	2406 mm/7 ft 11 in
(12) Grill to bucket cutting edge, carry position	1501 mm/4 ft 11 in	1501 mm/4 ft 11 in
(13) Maximum operating height	4174 mm/13 ft 8 in	4174 mm/13 ft 8 in
Jaw opening maximum	790 mm/2 ft 7 in	790 mm/2 ft 7 in
Bucket jaw clamping force	55.7 kN/12,524 lb	55.7 kN/12,524 lb
Weight (does not include teeth or forks)	662 kg/1,460 lb	685 kg/1,510 lb

IT Loader with Quick Coupler

	General Purpose (0.96 m ³ /1.25 yd ³)	General Purpose (1.00 m ³ /1.31 yd ³)	Multi Purpose (0.96 m ³ /1.25 yd ³)	Multi Purpose (1.03 m ³ /1.35 yd ³)
Capacity (SAE) rated	0.96 m ³ /1.25 yd ³	1.00 m ³ /1.31 yd ³	0.96 m ³ /1.25 yd ³	1.03 m ³ /1.35 yd ³
Width	2262 mm/7 ft 5 in	2406 mm/7 ft 11 in	2262 mm/7 ft 5 in	2406 mm/7 ft 11 in
Lift capacity at maximum height	3162 kg/6,970 lb	3152 kg/6,949 lb	2958 kg/6,521 lb	2916 kg/6,428 lb
Breakout force	47.0 kN/10,564 lb	47.3 kN/10,628 lb	48.5 kN/10,897 lb	48.3 kN/10,853 lb
(7) Maximum hinge pin height	3266 mm/10 ft 9 in	3266 mm/10 ft 9 in	3266 mm/10 ft 9 in	3266 mm/10 ft 9 in
(8) Dump angle at full height	43°	43°	43°	43°
Dump height at maximum angle	2462 mm/8 ft 1 in	2494 mm/8 ft 2 in	2531 mm/8 ft 4 in	2531 mm/8 ft 4 in
(9) Dump reach at maximum angle	862 mm/2 ft 10 in	830 mm/2 ft 9 in	751 mm/2 ft 6 in	751 mm/2 ft 6 in
(10) Maximum bucket rollback at ground level	40°	40°	40°	40°
(11) Digging depth	135 mm/5 in	135 mm/5 in	165 mm/6.5 in	165 mm/6.5 in
Maximum grading angle	107°	108°	111°	111°
Width of dozer cutting edge	N/A	N/A	2406 mm/7 ft 11 in	2406 mm/7 ft 11 in
(12) Grill to bucket cutting edge, carry position	1592 mm/5 ft 3 in	1562 mm/5 ft 2 in	1543 mm/5 ft 1 in	1543 mm/5 ft 1 in
(13) Maximum operating height	4204 mm/13 ft 10 in	4204 mm/13 ft 10 in	4223 mm/13 ft 10 in	4223 mm/13 ft 10 in
Jaw opening maximum	N/A	N/A	790 mm/2 ft 7 in	790 mm/2 ft 7 in
Bucket jaw clamping force	N/A	N/A	55.7 kN/12,524 lb	55.7 kN/12,524 lb
Weight (does not include teeth or forks)	431 kg/950 lb	445 kg/980 lb	662 kg/1,460 lb	685 kg/1,510 lb

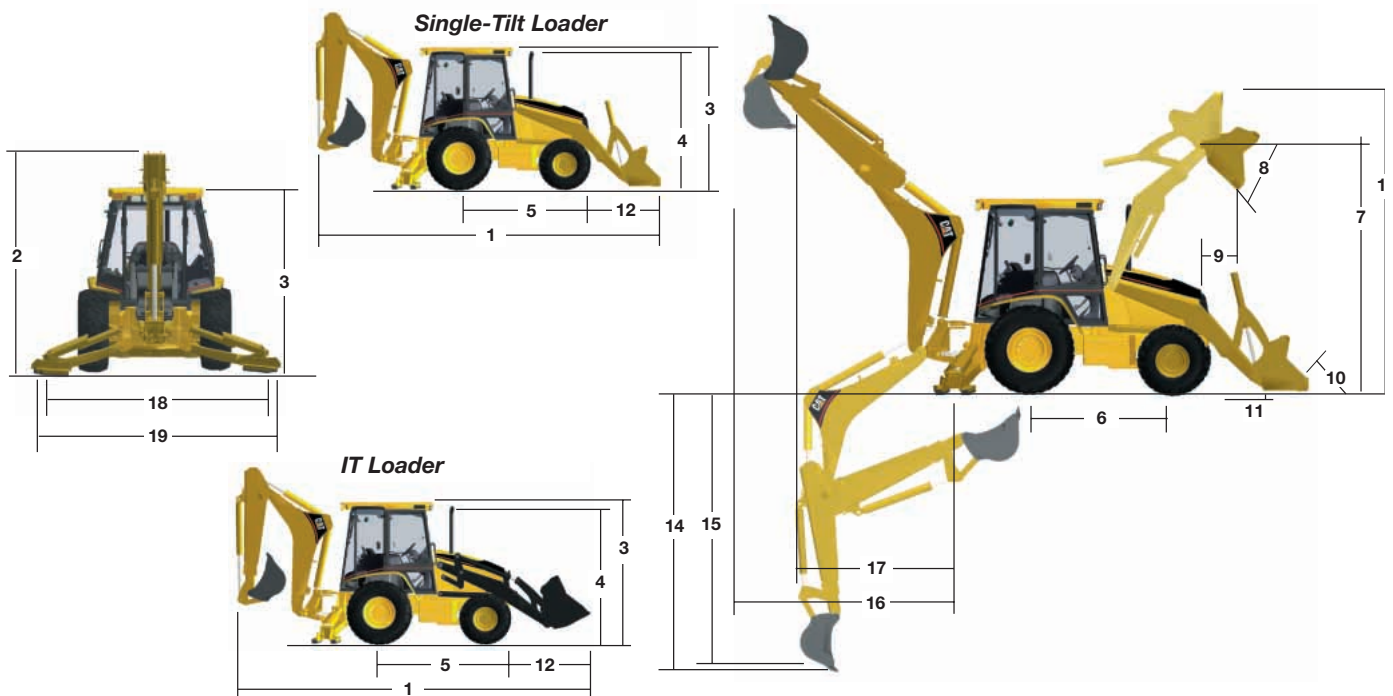

Backhoe Dimensions and Performance

	Standard Stick	Extendible Stick Retracted	Extendible Stick Extended
(14) Digging depth, SAE (max)	4390 mm/14 ft 5 in	4465 mm/14 ft 8 in	5510 mm/18 ft 1 in
(15) Digging depth, 2 ft flat bottom	4362 mm/14 ft 4 in	4432 mm/14 ft 7 in	5474 mm/18 ft 0 in
Reach from rear axle centerline at ground line	6740 mm/22 ft 1 in	6795 mm/22 ft 4 in	7765 mm/25 ft 6 in
(16) Reach from swing pivot at ground line	5650 mm/18 ft 6 in	5705 mm/18 ft 9 in	6675 mm/21 ft 11 in
Maximum operating height	5450 mm/17 ft 11 in	5470 mm/17 ft 11 in	6140 mm/20 ft 2 in
Loading height	3613 mm/11 ft 10 in	3630 mm/11 ft 11 in	4175 mm/13 ft 8 in
(17) Loading reach	1732 mm/5 ft 8 in	1819 mm/6 ft 0 in	2736 mm/9 ft 0 in
Swing arc	180°	180°	180°
Bucket rotation	205°	205°	205°
(18) Stabilizer spread, operating position (center of pad)	3219 mm/10 ft 7 in	3219 mm/10 ft 7 in	3219 mm/10 ft 7 in
(19) Stabilizer spread, operating position (outside edge of pad)	3689 mm/12 ft 1 in	3689 mm/12 ft 1 in	3689 mm/12 ft 1 in
Stabilizer spread, transport position	2352 mm/7 ft 9 in	2352 mm/7 ft 9 in	2352 mm/7 ft 9 in
Bucket dig force	65.4 kN/14,712 lb	64.8 kN/14,586 lb	64.8 kN/14,586 lb
Stick dig force	38.2 kN/8,593 lb	37.5 kN/8,421 lb	27.5 kN/6,188 lb

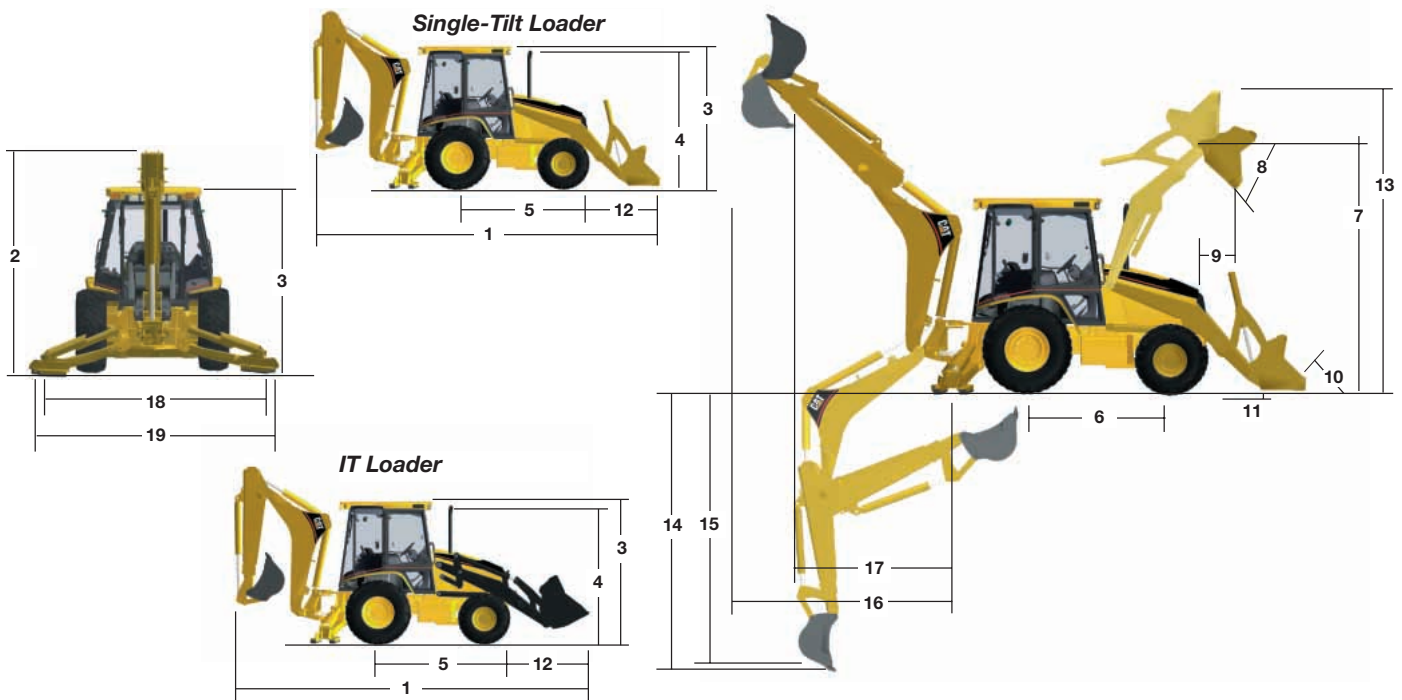

Dimensions with Forks/Material-Handling Arm

Cat 420D IT Operating Specifications with Forks

Fork Tine Length:	1050 mm/3 ft 5 in	1200 mm/3 ft 11 in	1350 mm/4 ft 5 in
Operating load (SAE J1197)	1885 kg/4,155 lb*	1808 kg/3,985 lb*	1737 kg/3,829 lb*
Operating load (CEN474-4)	2290 kg/5,049 lb*	2279 kg/5,025 lb*	2270 kg/5,003 lb*
Overall length (A)	7464 mm/24 ft 6 in	7614 mm/25 ft 0 in	7764 mm/25 ft 6 in
Load center	525 mm/1 ft 9 in	600 mm/2 ft 0 in	675 mm/2 ft 3 in

*Tip limited.

Specifications include lubricants, full fuel tank, ROPS cab, 80 kg (176 lb) operator, 355 kg (780 lb) counterweight, standard tires, standard stick, 24-inch standard-duty bucket, 2WD.

Machine stability is affected by machine options and backhoe attachments.

All dimensions are approximate.

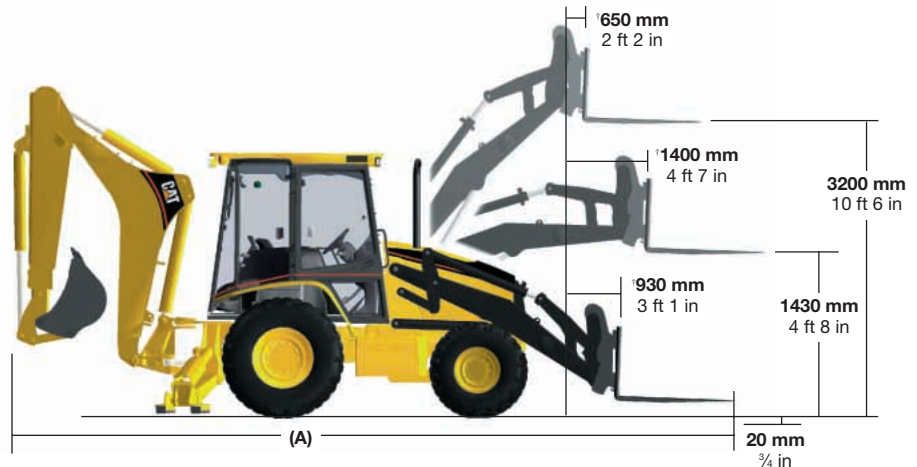

†Measured from nose of machine.

Cat 420D IT Operating Specifications with Material-Handling Arm

Material-Handling Arm Position:	Retracted	Mid-Position	Extended
Operating load (SAE J1197 & CEN474-4)	967 kg/2,131 lb**	612 kg/1,349 lb**	448 kg/988 lb**
Overall length, maximum	8574 mm/28 ft 2 in	9574 mm/31 ft 5 in	10574 mm/34 ft 8 in

Specifications include lubricants, full fuel tank, ROPS cab, 80 kg (176 lb) operator, 355 kg (780 lb) counterweight, standard tires, standard stick, 24-inch standard-duty bucket, 2WD.

Machine stability is affected by machine options and backhoe attachments.

All dimensions are approximate.

**Hydraulic limited.

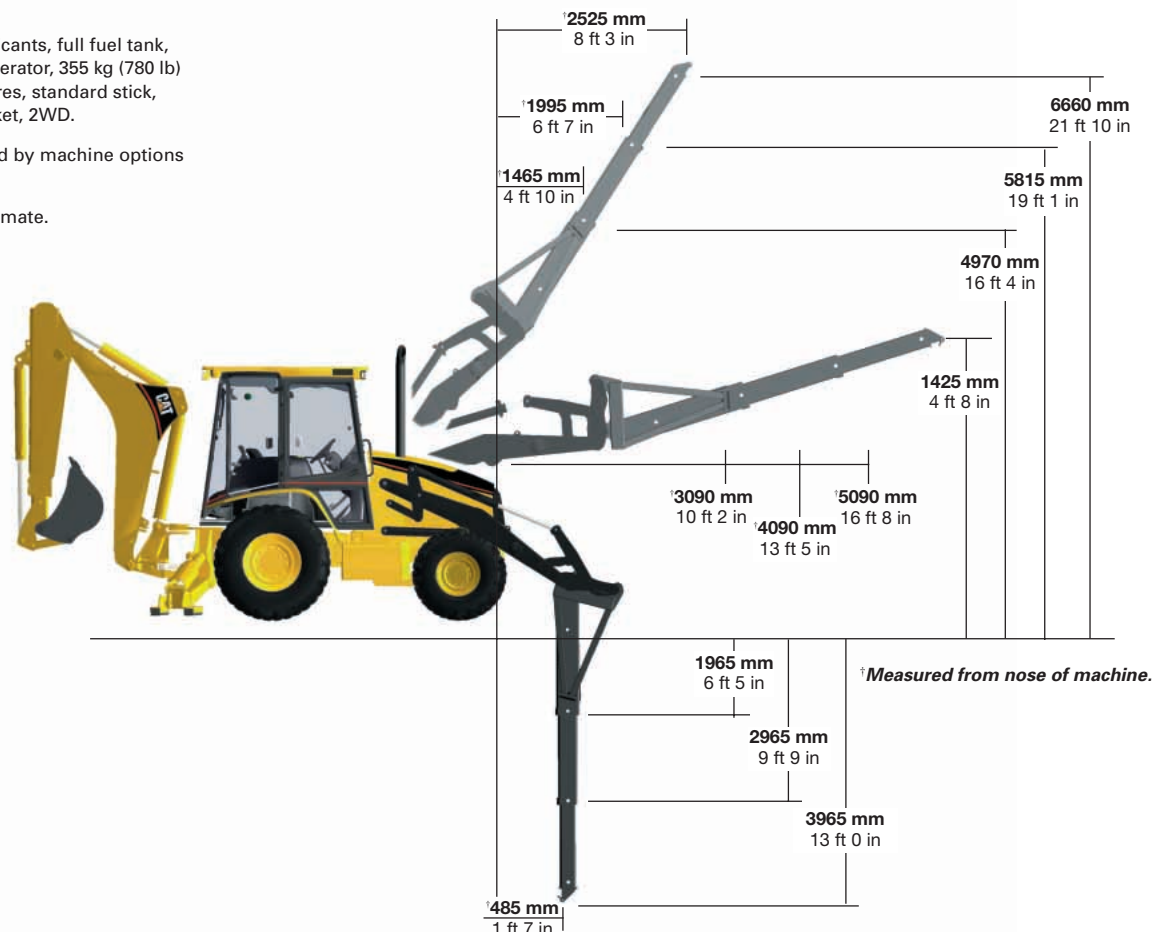

†Measured from nose of machine.

Backhoe Lift Capacity

Standard and optional equipment may vary. Consult your Caterpillar dealer for details.

Cat 420D/420D IT Standard Stick

KEY

- A — Boom lift **kg lb**
- B — Stick lift **kg lb**

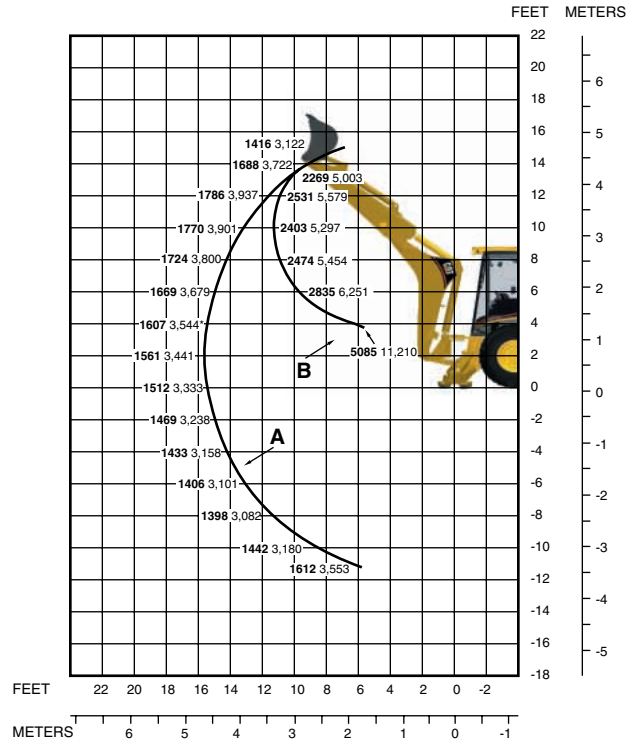

Cat 420D/420D IT Extendible Stick — Retracted

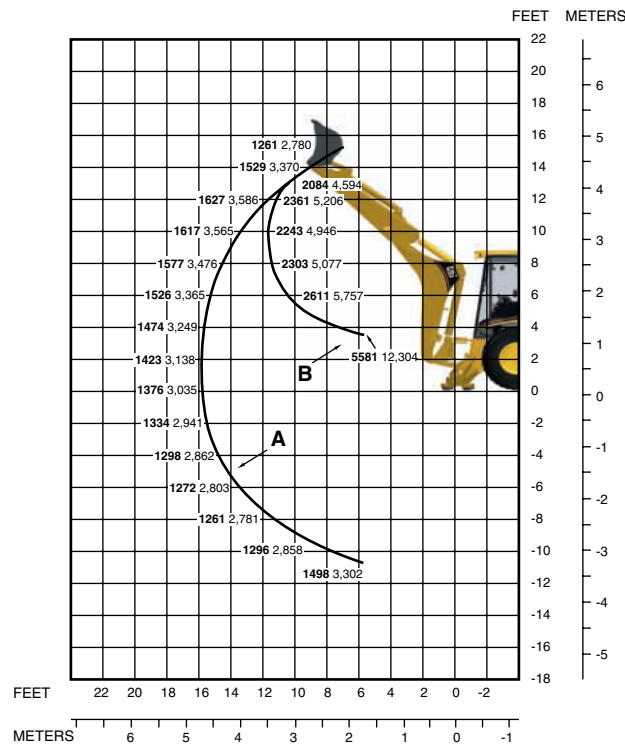

Cat 420D/420D IT Extendible Stick — Extended

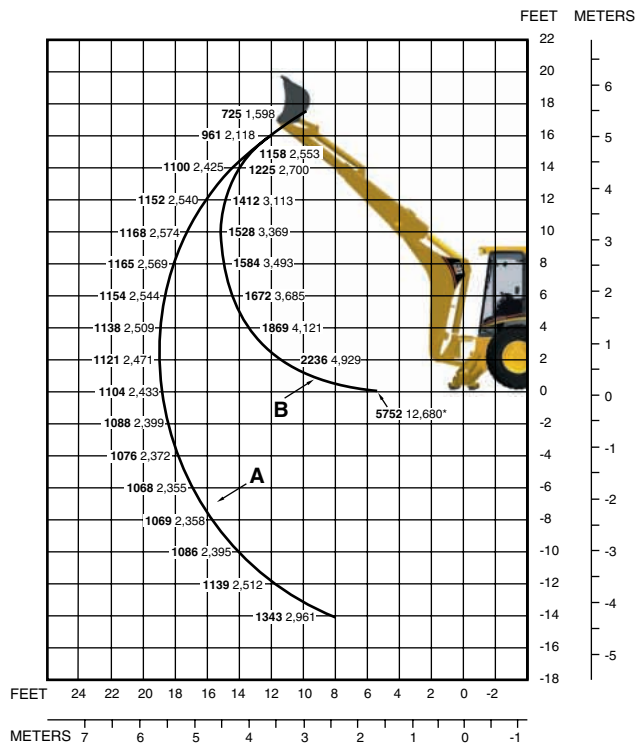

Lift capacities are over-end values. Machine equipped with 2WD, OROPS, 0.96 m³ (1.25 yd³) general-purpose bucket, and 355 kg (780 lb) counterweight. Extendible stick includes 567 kg (1,250 lb) counterweight.

* Indicates lift capacity is stability limited.

Standard Equipment

Standard equipment may vary. Consult your Caterpillar dealer for details.

Air cleaner	Hydraulic hose, XT-3 ES
Alarm, back-up	Hydraulic oil cooler
Alarm, audible system fault	Indicators
Alternator, 120-amp, 12-volt	Air cleaner service, water separator service, brake on, engine coolant, hydraulic oil level sight gauge, oil pressure
Axle, pendulum mount (front)	Instrument panel lights
Backhoe, center pivot, excavator-style	Joystick controls
Battery, maintenance-free, 880 CCA	pilot operated, excavator-style with pattern changer
Boom transport lock	Key start/stop system
Brace, lift cylinder	Lights, working (4 front, 4 rear)
Brake, secondary parking	Loader
Brakes, oil disk, dual pedals, interlock	Self-leveling, return-to-dig and transmission disconnect switch
Bucket level indicator	Mirror, rearview
Canopy, ROPS/FOPS	Receptacle, 12-volt, internal and external
Coat hook	Power steering, hydrostatic
Coolant/Antifreeze, extended life	Radio installation kit
Counterweight, bumper	Seat belt, retractable (51 mm/2 in)
Cushion swing system	Seat, air suspension, fabric or vinyl cover, armrests
Differential lock	Stabilizer controls, pilot operated
Dome light (cab only)	Stabilizer shoes, grouser style
Engine, Cat 3054C DIT (Direct Injection Turbocharged)	Starting system, thermal starting aid
Engine enclosure	Storage compartment, internal
Face seals, O-ring	Stop and tail lights (2)
Fan, suction and guard	Swing transport lock
Fast reversing shuttle, all gears	Tilt steering wheel
Filters, spin-on fuel	Tires
Engine oil, transmission oil, water separator, hydraulic fluid	Toolbox, external, lockable
Flashing hazard/signal lights	Torque converter
Floor mat	Throttles, hand and foot
Gauges	Transmission, four speed, syncromesh
Coolant temperature, fuel level, tachometer, hour meter, torque converter oil temperature	Transmission neutralizer switch
Grill, front with bumpers	Transport tie-downs
Ground line fuel fill	Warning horn, rear, electric

Optional Equipment

With approximate change in operating weight (kg/lb).

Air conditioning45/99	Cab, Standard with		Hydraulic valves, backhoe	
Attachments, backhoe		air conditioning251/554	Auxiliary valve	
Mechanical Quick Coupler		Canopy Plus, ROPS14/30	(standard stick)5/11
D-Series buckets75/165	Coolant, additional protection		Auxiliary valve	
C-Series buckets75/165	(–50° C/–58° F)0/0	(extendible stick)5/11
D and Deere buckets75/165	Counterweights		Hydraulic lines	
D and Case buckets80/176	Base145/320	Auxiliary, 2-way lines	
Attachments, front loader		Counterweight, 320145/320	(to boom)10/22
General-purpose buckets		Counterweight, 550249/550	Universal, 1-way lines	
0.96 m ³ /1.25 yd ³431/950	Counterweight, 1010458/1,010	(to stick)45/99
1.00 m ³ /1.31 yd ³439/968	Counterweight, 1250567/1,250	Quick disconnects2/4
1.07 m ³ /1.40 yd ³444/980	Stackable		Loader, IT with QC and	
Multi-purpose bucket		One105/230	Pilot loader control338/745
0.96 m ³ /1.25 yd ³662/1,460	Two249/550	Ride Control25/55
0.96 m ³ /1.25 yd ³		(Base + one 105/230 section)		Rotating beacon	
w/forks832/1,835	Three458/1,010	Fixed mounted5/11
1.03 m ³ /1.35 yd ³723/1,595	(Base + two 105/230 sections)		Magnetic mounted5/11
1.03 m ³ /1.35 yd ³		Also available567/1,250	Seat belt, 75 mm/3 in0/0
w/forks855/1,885	(Base + one 105/230 section		Stabilizers	
Carriage, fork	–63/–139	and one 317/700 section)		Street pads, rubber (set of 4)37/82
Material-handling arm	–65/–143	Cutting edge, bolt-on		Reversible pads38/84
Axle, front		Two piece70/154	Stick, extendible245/540
All-wheel drive with		Fenders, AWD, front12/26	Teeth, loader bucket45/99
driveshaft guard135/298	Guards:		Transmission, Auto-shift25/55
Battery, additional, 880 CCA27/60	Stabilizer, rock30/65	Vandalism protection	
Cab, Deluxe212/467	High ambient cooling package2/4	Gauge cover1/2
Cab, Deluxe with		Hydraulic valves, loader		Padlocks1/2
air conditioning251/554	3rd valve for GP, MP or		Hood lock0/0
Cab, Standard212/467	Quick Coupler27/60		

*Included in base machine weight

Cab, Deluxe includes deluxe seat, auto-up stabilizers, voltmeter, and system monitors for plugged engine air filter, hydraulic filter and fuel/water separator.

Notes

Notes

420D/420D IT Backhoe Loader

AEHQ5577-01 (3-04)

Replaces AEHQ5577

For more complete information on Cat products, dealer services,
and industry solutions, visit us on the web at www.CAT.com

© 2004 Caterpillar
Printed in U.S.A.

Materials and specifications are subject to change without notice.
Featured machines in photos may include additional equipment.
See your Caterpillar dealer for available options.

CATERPILLAR[®]