

CHAMPION

POWER EQUIPMENT ^{TM-MC}

OWNER'S MANUAL & OPERATING INSTRUCTIONS



4500 lb. WINCH



MODEL NUMBER

14051

SAVE THESE INSTRUCTIONS
Important Safety Instructions
are included in this manual.

MADE IN CHINA
REV 14051-20160719

12039 Smith Ave.
Santa Fe Springs CA 90670
USA / 1-877-338-0999
www.championpowerequipment.com

Have questions or need assistance?

Do not return this product to the store!

WE ARE HERE TO HELP!

Visit our website:

www.championpowerequipment.com

for more info:

- Product Info & Updates
- Tech Bulletins
- Frequently Asked Questions
- Product Registration

– or –

Call our Customer Care Team Toll-Free at:

1-877-338-0999

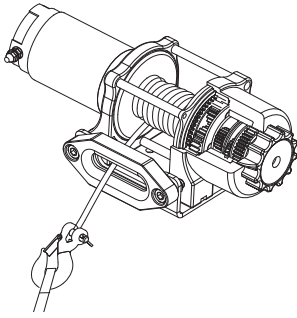

4500 lb. WINCH

TABLE OF CONTENTS

Introduction	1	Operation	9
Introduction	1	General Tips for Safe Operation	9
This Booklet	1	Self Recovery	9
Accessories	1	Synthetic Rope Abrasion Sleeve	10
Manual Conventions	2	Winching Techniques A-Z	10
Safety Rules	3	Maintenance	11
Controls and Features	5	Lubrication	11
Winch	5	Synthetic Rope Replacement	11
Assembly	6	Synthetic Rope	11
Mounting the Winch	6	Specifications	12
Solenoid/Contactor Location	6	Performance Specifications	12
Install the Rocker Switch	6	Parts Diagram	13
Wiring the Winch	7	Parts List	14
Wiring Diagram	8	Troubleshooting	15
Switch Wiring Diagram	8		

INTRODUCTION

Introduction

Congratulations on your purchase of a Champion Power Equipment winch. CPE designs and builds winches to strict specifications. With proper use and maintenance, this winch will bring years of satisfying service.

This Booklet

Every effort has been made to ensure the accuracy and completeness of the information in this manual. We reserve the right to change, alter and/or improve the product and this document at any time without prior notice.

Accessories

Champion Power Equipment manufactures and sells accessories designed to help you get the most from your purchase. To find out more about our covers, tree savers, hooks, fairleads, etc., please visit our website at:

→ www.championpowerequipment.com

Record the model and serial numbers as well as date and place of purchase for future reference. Have this information available when ordering parts and when making technical or warranty inquiries.

Champion Power Equipment Support
1-877-338-0999
Model Number
14051
Serial Number
Date of Purchase
Purchase Location

This manual uses the following symbols to help differentiate between different kinds of information. The safety symbol is used with a key word to alert you to potential hazards in operating and owning power equipment.

Follow all safety messages to avoid or reduce the risk of serious injury or death.

 **DANGER**

DANGER indicates an imminently hazardous situation which, if not avoided, **will** result in death or serious injury.

 **WARNING**

WARNING indicates a potentially hazardous situation which, if not avoided, **could** result in death or serious injury.

 **CAUTION**

CAUTION indicates a potentially hazardous situation which, if not avoided, **may** result in minor or moderate injury.

CAUTION

CAUTION used without the safety alert symbol indicates a potentially hazardous situation which, if not avoided, **may** result in property damage.

 **NOTE**

If you have questions regarding your winch, we can help. Please call our help line at **1-877-338-0999**

SAFETY RULES

WARNING

Read this manual thoroughly before operating your winch. Failure to follow instructions could result in serious injury or death.

WARNING

Do not exceed the rated capacity.

DANGER

Do not use this winch for lifting or moving people or animals.

DANGER

Keep yourself and others a safe distance to the side of the cable when under tension.

DANGER

Never step over a cable or near a cable under load.

WARNING

The wire rope may break before the motor stalls. For heavy loads at or near rated capacity, use a pulley block/snatch block to reduce the load on the wire rope.

WARNING

Do not move the vehicle to pull a load (towing) on the winch cable. This could result in cable breakage.

WARNING

Do not use the winch to secure or hold a vehicle for a long period of time. Do not use the winch to secure a vehicle for transport.

WARNING

Disconnect the remote control and battery leads when not in use.

WARNING

Avoid “shock loads” by using the control switch intermittently to take up the slack in the wire rope. “Shock loads” can far exceed the rate capacity for the wire rope and drum.

Do not accelerate your vehicle while winching. Loss of traction can cause a shock load on the cable.

CAUTION

Use hook strap when handling the hook for spooling or unspooling the wire rope.

⚠ WARNING

When re-spooling the cable, ensure that the cable spools in the under-wind position with the cable entering the drum from the bottom, not the top.

To re-spool correctly, and while wearing gloves, keep a slight load on the cable while pushing the remote button to draw in the cable. Walk toward the winch not allowing the cable to slide through your hands. Do not let your hands get within 30 cm (12 in.) of the winch while re-spooling. Turn off the winch and repeat the procedure until a few feet of cable are left. Disconnect the remote control and finish spooling by rotating the drum by hand with the clutch disengaged. Keep hands clear of the fairlead and drum while the winch is under power .

⚠ WARNING

Do not use as a hoist. Do not use for overhead lifting.

⚠ CAUTION

Use gloves to protect hands when handling the cable. Never let the cable slide through your hands.

⚠ CAUTION

Do not wrap the cable around any object and hook it back onto itself.

⚠ CAUTION

Duration of winching pulls should be kept as short as possible.

If the motor becomes uncomfortably hot to the touch, stop winching immediately and let it cool down for a few minutes. Do not pull for more than one minute at or near the rated load.

⚠ CAUTION

If the motor stalls, do not maintain power to the winch.

Electric winches are designed and made for intermittent use and should not be used in constant duty applications.

⚠ CAUTION

Apply blocks to the wheels of the vehicle when on an incline.

⚠ CAUTION

Never release the free-spool clutch when there is a load on the winch.

CONTROLS AND FEATURES

Read this owner's manual before operating your winch. Familiarize yourself with the location and function of the controls and features. Save this manual for future reference.

Winch

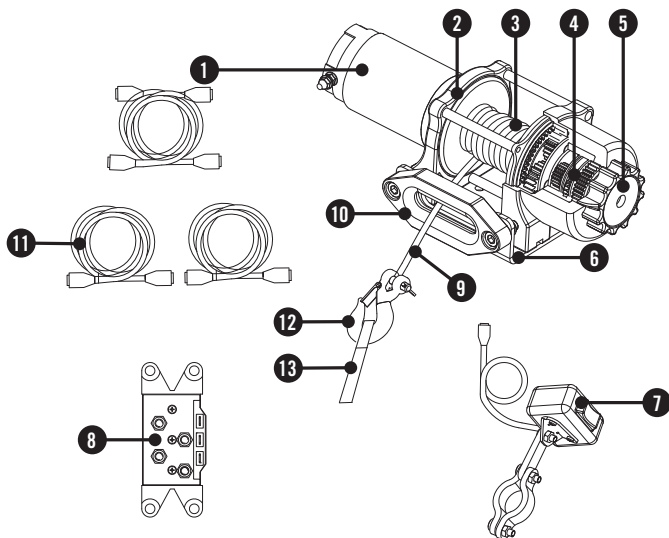

- (1) **Motor** - 1.6 HP/1.2 kW 12V DC motor provides power to the planetary gear mechanism.
- (2) **Braking System** - Braking action is automatically applied to the winch drum when the winch motor is stopped and there is a load on the wire rope.
- (3) **Winch Drum** - The winch drum is the cylinder on which the wire rope is stored. It can feed or wind the rope depending on the remote winch switch.
- (4) **Planetary Gear System** - The reduction gears convert the winch motor power into extreme pulling forces. This system allows high torque while maintaining compact size and light weight.
- (5) **Free Spooling Clutch** - The clutch allows the operator to manually disengage ("Out") the spooling drum from the gear train, free spool. Engaging the clutch ("In") locks the winch into the gear system.
- (6) **Mounting Channel**
- (7) **Rocker Switch** - Rocker switch with handlebar mount for powering the rope in or out of your winch drum.
- (8) **Solenoid/Contactor** - Power from the vehicle battery flows through the weather sealed contactor before being directed to the winch motor.
- (9) **Synthetic Rope** - 15/64 in. x 38 ft. Synthetic Rope designed specifically for load capacity of 4,500 lb. The synthetic rope feeds onto the drum in the "under wind" position through the Aluminum Hawse (10) and is looped at the end to accept the clevis hook pin.
- (10) **Aluminum Hawse** - When using the winch at an angle the hawse acts to guide the synthetic rope onto the drum and minimizes damage to the synthetic rope from abrasion on the winch mount or bumper.
- (11) **Winch Connection Cables** - Used to connect the contactor to the winch motor.
- (12) **Clevis Hook** - Provides a means for connecting the looped ends of cables to an anchor.
- (13) **Strap** - Used to assist cable feed.

Mounting the Winch

This CPE 4,500 lb. winch is designed with a bolt pattern that is standard in this class of winch. Many winch mounting kits are available that utilize this bolt pattern for the most popular trucks, SUV's and ATV's. If you cannot find a kit locally, contact CPE and we will provide you with the name of a dealer.

! CAUTION

Mounting bolts must be SAE grade 5 or better and torque to 34 ft. lbs.

1. Insert M10x25 bolts through the mounting channel holes and attach the aluminum hawse to the mounting channel with the M10 lock nuts provided.

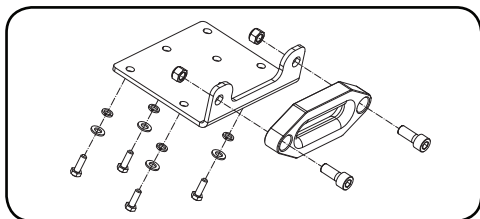

2. Turn the winch upside down. Place the mounting channel on the winch, making sure the winch is centered in the middle of it.
3. Thread the M8x25 bolts through the M8 flat and lockers washers, and then thread through the mounting channel. Tighten the bolts. DO NOT over tighten.
4. Turn winch right side up. Disengage the clutch by moving the Cam Ring to the "Out" position. Release the wire rope and pull through the aluminum hawse.
5. Attach the clevis hook to the cable, and then hand strap to the clevis hook.

CAUTION

If utilizing a mounting plate, ensure that the three major sections (motor, drum and gear housing) are properly aligned. Proper alignment of the winch will allow for even distribution of the full rated load.

Mounting the Winch Cont'd.

NOTE

The type of vehicle to which the winch and mounting channel will be applied, will dictate the type of mounting kit that should be used (Speed Mount™ Hitch Adapter, Standard Mounting Channel, or Specialty Mounting Kit).

Solenoid/Contactor Location

Find a location for the solenoid/contacter. It is recommended that the solenoid/contacter be mounted close to the battery in a clean, dry location. Make sure the location chosen allows for sufficient clearance from all metal components. Drill mounting holes if required. Once a location is found, DO NOT install the unit until all wiring is completed (see wiring section).

NOTE

Terminals coming in contact with metal will cause a direct short, possibly causing solenoid/contacter and/or battery damage.

Install the Rocker Switch

1. Decide which handlebar the rocker switch will be mounted on. (The rocker switch is usually installed on the left handlebar).
2. Use a piece of electrical tape (not provided) around the handlebar to help prevent rotation of the mount.
3. Tighten the rocker switch in place. DO NOT overtighten or tighten/clamp over any hoses or cables.
4. Once the rocker switch is mounted, the wires can be routed back to where the solenoid/contacter is located.
5. Make sure the handlebars have full range of motion and then secure the rocker switch's cable with the supplied cable ties.

ASSEMBLY

Wiring the Winch

⚠ CAUTION

NEVER route electrical cables across any sharp edges, through and/or near moving parts, or near parts that may become hot.

⚠ CAUTION

Battery cables should **NOT** be drawn taut. Leave some slack for cable movement.

💬 NOTE

You may need to use a test light to locate a suitable wire. The wire should only have power when the key is in the ON position.

💬 NOTE

Depending on the location of the solenoid/contactor, you may need to use the black and red cables in place of the yellow and blue, and the yellow and blue in place of the red and black. Just remember that this also changes the diagram.

1. Connect the yellow and blue cables to the motor terminals on the winch. (Yellow to the positive (+) terminal of the motor. Blue to the negative (-) terminal of the motor). Tighten the terminal nuts on the motor. **DO NOT** over tighten. Route the other ends to the solenoid/contactor location.
2. Connect the yellow and blue cables to the solenoid/contactor (yellow to yellow and blue to blue). **DO NOT** tighten nuts.
3. Connect the red and black cables to the solenoid/contactor (red to red and black to black). **DO NOT** tighten nuts. Route the other ends to the vehicle's battery.
4. Connect the red lead to the positive (+) terminal of the vehicle's 12 volt battery.
5. Connect the rocker switch to the solenoid/contactor (black to black and green to green).

Wiring the Winch Cont'd.

6. Splice the end of the red wire on the rocker switch, to an ignition (keyed) controlled power source using the supplied wire tap.
7. Once all wiring is connected to the solenoid/contactor it can then be mounted using the supplied M6 hardware.
8. Tighten the solenoid/contactor terminal nuts. **DO NOT** over tighten.
9. Connect the black lead to the negative (-) terminal of the vehicle's 12 volt battery.
10. Place all terminal boots over terminals and secure all cables with cable ties or electrical tape (not included).
11. Check for proper drum rotation. Pull and turn the clutch knob to the "Out" position (free spooling). Pull out some cable from the drum, and then turn the clutch knob to the "In" position to engage the gears. Press the cable out button on the rocker switch. If the drum is turning and releasing more cable, then your connections are accurate. If the drum is turning and collecting more cable then reverse the leads on the motor. Repeat and check rotation.

Wiring Diagram

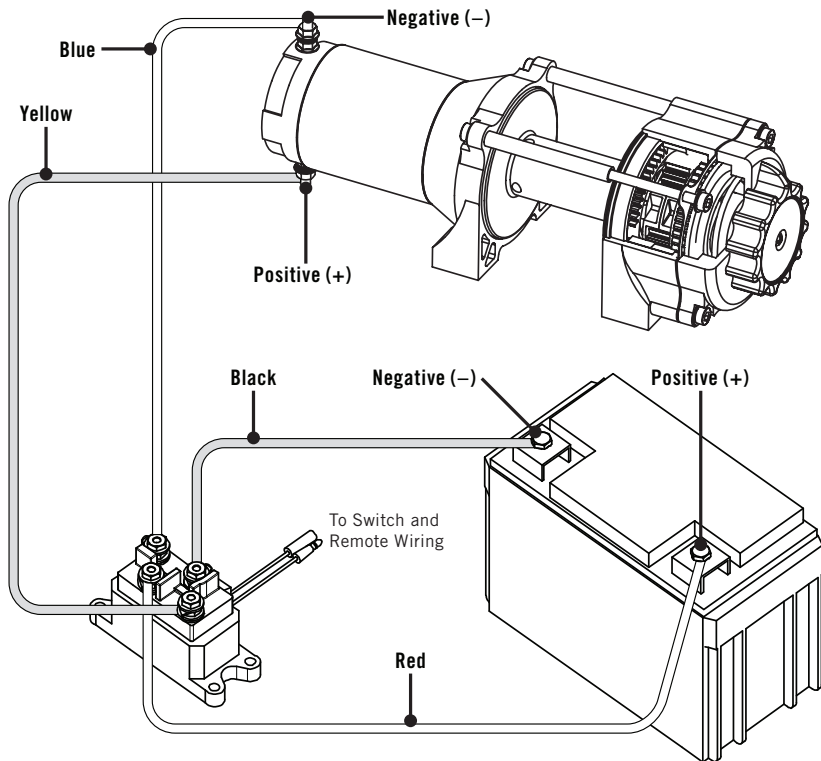

Switch Wiring Diagram

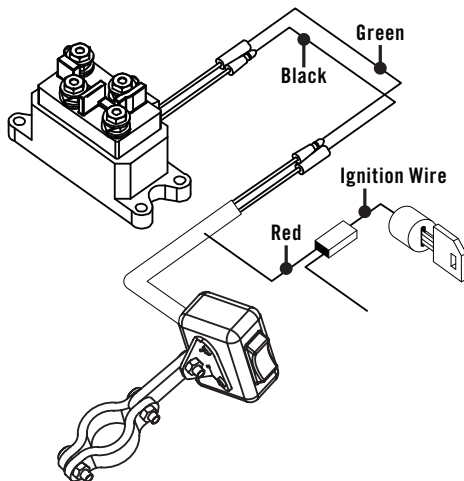

OPERATION

General Tips for Safe Operation

Your 14051 winch is rated at a 4,500 lb.

(2041 kg) capacity in first layer (max) when spooling the first rope layer on the drum. Overloads can damage the winch, motor and/or synthetic rope. For loads over 2,250 lb. (1021 kg) we recommend the use of the pulley block/snatch block to double the synthetic rope line. This will aid in two ways:

- reduce the number or rope layers on the drum, as well as,
- reduce the load on the wire rope by as much as 50%.

When doubling the line back to the vehicle, attach to the tow hook, frame or other load bearing part. The vehicle engine should be kept running during operation of the winch to minimize battery drain and maximize power and speed of the winch. If the winch is used for a considerable time with the engine off the battery may be drained and too weak to restart the motor.

Get to know your winch before you actually need to use it. We recommend that you set up a few test runs to familiarize yourself with rigging techniques, the sounds your winch makes under various loads, the way the rope spools on the drum, etc.

Inspect the synthetic rope and equipment before each use. A frayed or damaged rope shall be replaced immediately. Use only manufacturer's identical replacement rope with the exact specifications.

Inspect the winch installation and bolts to ensure that all bolts are tight before each operation. Store the remote control inside your vehicle in a place that it will not be damaged.

Any winch that appears to be damaged in any way, is found to be worn, or operates abnormally **MUST BE REMOVED FROM SERVICE UNTIL REPAIRED**. It is recommended that the necessary repairs be made by a manufacturer's authorized repair facility. Pull only on areas of the vehicle as specified by the vehicle manufacturer. Only attachments and/or adapters supplied by the manufacturer are to be used.

Self Recovery

Locate a suitable anchor such as a strong tree trunk or boulder. Always use a sling as an anchor point.

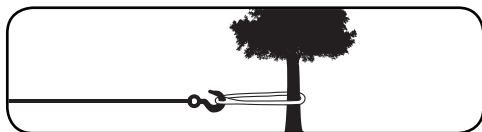

Your winch is equipped with an aluminum hawse to help guide the synthetic rope and to reduce binding on short side pulls. Do not winch from an acute angle as the synthetic rope will pile up on one side of the drum causing damage to synthetic rope and the winch.

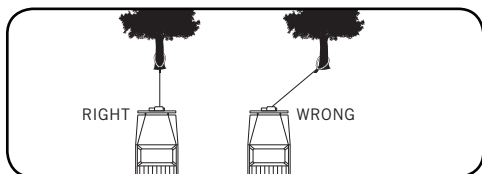

Short pulls from an angle can be used to straighten the vehicle. Long pulls should be done with the synthetic rope at a 90° angle to the winch/vehicle. When pulling a heavy load, place a blanket or jacket over the synthetic rope five or six feet from the hook.

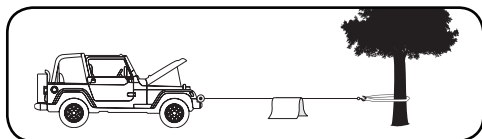

In the event of a broken cable it will dampen the snap back. For additional protection open the hood of the vehicle. For pulls over 2,250 lb. (1021 kg), we recommend the use of the snatch block/pulley block to double line the synthetic rope.

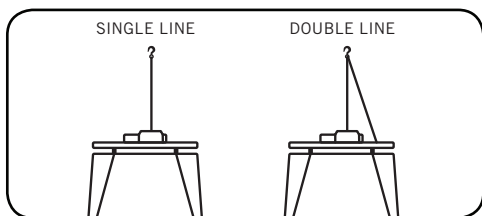

This reduces the load on the winch and the strain on the rope by approximately 50%.

Synthetic Rope Abrasion Sleeve

The winch should be set up to avoid any rough surface from contacting the rope. If that is not possible, the abrasion sleeve can be used to help protect the rope. (A)

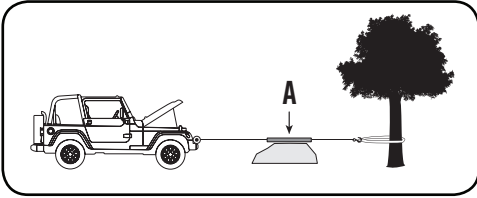

Winching Techniques A-Z

- (a) Take time to assess your situation and plan your pull.
- (b) Put on gloves to protect your hands.
- (c) Disengage the clutch to allow free-spooling and also save battery power.
- (d) Attach the hook strap to the clevis hook.
- (e) Pull out the synthetic rope to your desired anchor point using the hook strap.
- (f) Secure the clevis hook to the anchor point: Sling, chain or snatch block. Do not attach the hook back onto the synthetic rope.
- (g) Engage the clutch.
- (h) Connect the remote control to the winch. If you are going to control the winch from inside your vehicle then pass the remote through an open window to avoid the wires being pinched in the door.
- (i) Start your engine to ensure power is being replenished to the battery.
- (j) Drape a blanket or jacket over the synthetic rope approximately 5 to 6 feet from the hook. Open the hood for added protection.
- (k) Power in the synthetic rope guiding the rope under tension to draw up the slack in the rope. Once the rope is under tension, stand clear. Never step over the synthetic rope.
- (l) Double check your anchors and make sure all connections are secure.
- (m) Inspect the synthetic rope. Make sure there are at least 5 wraps of synthetic rope around the winch drum.

Winching Techniques A-Z Cont'd.

- (n) Clear the area. Make sure all spectators stand clear and that no one is directly in front or behind the vehicle or anchor point.
- (o) Begin winching. Be sure that the synthetic rope is winding evenly and tightly around the drum. The vehicle that is being winched can be slowly driven to add assistance to the winching process. Avoid shock loads; keep the synthetic rope under tension.
- (p) The vehicle to be winched should be placed in neutral and the emergency brake released. Only release the brake pedal when under full tension. Avoid shock loads to the winch. This can damage the winch, rope and vehicle.
- (q) The winch is meant for intermittent use. Under full load with a single line rig do not power in for more than a minute without letting the motor cool down for a few minutes and then resume the winching operation.
- (r) The winching operation is complete once the vehicle is on stable ground and is able to drive under its own power.
- (s) Secure the vehicle. Be sure to set the brakes and place the vehicle in park.
- (t) Release the tension on the synthetic rope. The winch is not meant to hold the vehicle for long periods of time.
- (u) Disconnect the synthetic rope from the anchor.
- (v) Rewind the synthetic rope. Make sure that any rope already on the drum has spooled tightly and neatly. If not, draw out the rope and re-spool from the point where the rope is tight.
- (w) Keep your hands clear of the winch drum and hawse as the synthetic rope is being drawn in.
- (x) Secure the hook and hook strap.
- (y) Disconnect the remote control and store in a clean, dry place.
- (z) Clean and inspect connections and mounting hardware for next winching operation.

MAINTENANCE

The owner/operator is responsible for all periodic maintenance.

WARNING

Never operate a damaged or defective winch.

WARNING

Improper maintenance will void your warranty.

Complete all scheduled maintenance in a timely manner. Correct any issue before operating the winch.

NOTE

For service or parts assistance, contact our help line at **1-877-338-0999**

Lubrication

All moving parts within the Electric Winch having been Lubricated using high temperature lithium grease at the factory. No internal lubrication is required. Lubricate Cable Assembly periodically using a light penetrating oil.

Synthetic Rope Replacement

It is recommended that any modifications be performed by a manufacturer's authorized repair facility, and that only manufacturer-supplied parts be used.

1. Move the clutch to the "Out" position.
2. Extend Synthetic Rope to its full length.
Note how the existing rope is connected to the inside of the drum.
3. Remove old Synthetic Rope and attach new one.
4. Retract Synthetic Rope onto drum being careful not to allow kinking.

Synthetic Rope

Periodically rinse the synthetic rope with water to remove any sand, dirt, mud, or debris that can become embedded or build up in the rope during use. This will help extend the life of the rope.

NOTE

Inspect rope before and after each use. If rope becomes frayed it must be replaced.

Performance Specifications

- Rated Pull	4,500 lb (2041 kg)
- Gear Reduction Ratio	180:1
- Motor	Permanent Magnet 1.6 HP/1.2 kW (12V DC)
- Duty Cycle	Intermittent
- Drum Size	1.7 in. (D) x 3.2 in. (L) [44 mm(D) x 80 mm(L)]
- Synthetic Rope	15/64 in. (D) x 38 ft. (L) [6 mm(D) x 11.6 m(L)]
- Gross Weight	24.3 lb. (11 kg)
- Net Weight	21.6 lb. (9.8 kg)
- Height	4.9 in. (12.4 cm)
- Width	4.5 in. (11.5 cm)
- Length	13.5 in. (34.4 cm)
- Bolt Pattern	4.9 in. x 3 in. (12.4 cm x 7.6 cm)

Line Speed and Motor Current (First Layer)						
Line Pull	LB	0	1000	2000	3000	4500
	KG	0	454	907	1361	2041
Line Speed (12V DC)	FPM	12.8	9.8	8.5	6.9	3.3
	MPM	3.9	3.5	2.7	2.0	1.4
Motor Current (12V DC)	A	28	80	140	180	280
Running Time*	Minutes	1	1	1	1	1
Cooling Time**	Minutes	5	5	5	5	5

*If the motor becomes uncomfortably hot to the touch, stop winching immediately and let it cool down for 5 minutes. Do not pull for more than one minute at or near the rated load.

**Electric winches are designed and made for intermittent use and should not be used in constant duty applications.

Line Pull and Cable Capacity Per Layer					
Line of Cable		1	2	3	4
Rated Line Pull	LB	4500	3629	3041	2616
	KG	2041	1648	1380	1188
Cable Capacity	FT	6.7	15.0	24.9	38.0
	M	2.0	4.8	7.6	11.6

It is recommended to use double line and snatch block for pulling loads over 2,250 lb. (1021 kg).

SPECIFICATIONS

Parts Diagram

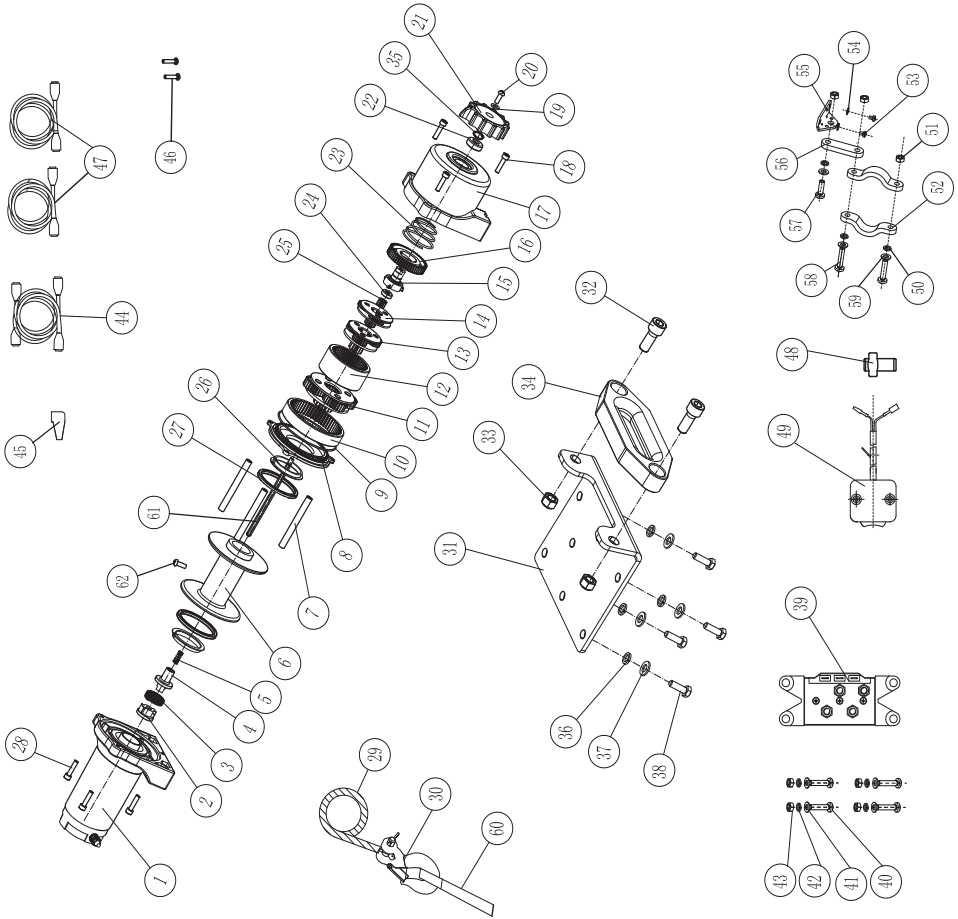

#	Part Number	Description	Qty
1	456100A-BF	Motor Assembly - Black Flat (Horizontal)	1
2	450001	Coupling, I	1
3	450002	Spring, Coupling	1
4	450003A	Coupling, II	1
5	410001	Spring	1
6	410200-BF	Drum Assembly - Black Flat	1
7	410002	Tie Bar	3
8	410003-BF	Gear Housing Cover -Black Flat	1
9	410004	O Ring 100x1.9	1
10	410005	Gear Ring I	1
11	410006	Gear Carrier Assembly, Output	1
12	410007A	Gear Ring II	1
13	410008	Gear Carrier Assembly, Intermediate	1
14	410009	Gear Carrier Assembly, Input	1
15	410010A	Axis Support Bushing	1
16	410011A	Cam Clutch Gear	1
17	410012-BF	Gear Housing - Black Flat	1
18	410013	Bolt M5 x 20	1
19	250002	Washer ø6, Flat	1
20	250018	Bolt M6 x 16	1
21	250016-BF	Clutch Cap - black Flat	1
22	GB2760BB6802-2Z	Radial Ball Bearing 6802-2Z Sealed	1
23	410014	Clutch Spring	1
24	GB2760BB0606-2Z	Radial Ball Bearing 0606-2Z Sealed	1
25	410015	Sun Gear, Input	1
26	410016	Drum Bushing	2
27	410017	Seal Ring	2
28	410018	Bolt M5 x 16	5
29	450900	Synthetic Rope - 15/64 in. (D) x 38 ft. (L), Grey (Smoke)	1
30	C20002	1/4 in. Clevis Hook - White Zinc	1
31	250086-BF	Mounting Channel - Black Flat	1
32	250087	Bolt M10 x 25	2
33	250036	Nut M10, Locking	2

#	Part Number	Description	Qty
34	250088	Aluminum Hawse - 124mm	1
35	250011	Circlip ø15	1
36	300020	Washer ø8, Locking	4
37	300019	Washer ø8, Flat	4
38	450021	Bolt M8 x 25	4
39	410019	Contactora	1
40	400011	Bolt M6 x 25	4
41	250002	Washer ø6, Flat	4
42	400028	Washer ø6, Locking	4
43	400013	Nut M6, Locking	4
44	456001	Battery Wires - Red, 36 in. (L) / 6 GAUGE	1
	456002	Battery Wires - Black, 36 in. (L) / 6 GAUGE	1
45	400017	Terminal Protector	8
46	250001	Bolt M6 x 20	2
47	456003	Winch Wires - Yellow, 72 in. (L) / 6 GAUGE	1
	456004	Winch Wires - Blue, 72 in. (L) / 6 GAUGE	1
48	400020	Wire Tap	1
49	400021	Mini-Rocker Switch	1
50	400023	Washer ø5, Flat	3
51	400025	Nut M5	3
52	400026-BF	Mini-Rocker Switch Clamp - Black Flat	2
53	400027	#6-32x9/32 in.	2
54	400028	Washer ø6, Locking	2
55	400029-BF	Mini-Rocker Switch Mounting Angle - Black Flat	1
56	400030-BF	Mini-Rocker Switch Extender - Black	1
57	400031	Bolt M5 x 18	1
58	400022	Bolt M5 x 25	2
59	400024	Washer ø5, Locking	3
60	410022	Yellow Strap	1
61	410025	Hexagonal Shaft	1
62	410024	Screw M6 x 8	1

TROUBLESHOOTING

Problem	Cause	Solution
Motor does not turn on	Loose battery cable connections	Tighten nuts on all cable connections
	Defective Switch Assembly	Replace Switch Assembly
	Defective motor	Check for voltage at armature port with Switch pressed. If voltage is present, Replace motor
	Water has entered motor	Allow to drain and dry. Run in short bursts without load until completely dry
Motor runs but Cable drum does not turn	Clutch not engaged	Move Clutch to the "In" position. If problem persists, a qualified technician needs to check and repair
Motor runs slowly or without normal power	Insufficient current or voltage	The battery is weak, recharge. Run winch with vehicle motor running (Battery should have a strong charge)
	Loose or corroded battery cable connections.	Clean, Tighten, or replace
Motor overheating	winch running time too long	Allow winch to cool down periodically
Motor runs in one direction only	Defective Switch Assembly	Replace Switch Assembly

For further technical support:

Technical Service

Mon – Fri 8:30 AM – 5:00 PM (PST/PDT)

Toll Free: 1-877-338-0999

tech@championpowerequipment.com

WARRANTY

WARRANTY

CHAMPION POWER EQUIPMENT
2 YEAR LIMITED WARRANTY

Warranty Qualifications

Champion Power Equipment (CPE) will register this warranty upon receipt of your Warranty Registration Card and a copy of your sales receipt from one of CPE's retail locations as proof of purchase.

Please submit your warranty registration and your proof of purchase within ten (10) days of the date of purchase.

Repair/Replacement Warranty

CPE warrants to the original purchaser that the mechanical and electrical components will be free of defects in material and workmanship for a period of two years (parts and labor) from the original date of purchase and 180 days (parts and labor) for commercial and industrial use. Transportation charges on product submitted for repair or replacement under this warranty are the sole responsibility of the purchaser. This warranty only applies to the original purchaser and is not transferable.

Do Not Return The Unit To The Place Of Purchase

Contact CPE's Technical Service and CPE will troubleshoot any issue via phone or e-mail. If the problem is not corrected by this method, CPE will, at its option, authorize evaluation, repair or replacement of the defective part or component at a CPE Service Center. CPE will provide you with a case number for warranty service. Please keep it for future reference. Repairs or replacements without prior authorization, or at an unauthorized repair facility, will not be covered by this warranty.

Warranty Exclusions

This warranty does not cover the following repairs and equipment:

Normal Wear

Products with mechanical and electrical components need periodic parts and service to perform well. This warranty does not cover repair when normal use has exhausted the life of a part or the equipment as a whole.

Installation, Use and Maintenance

This warranty will not apply to parts and/or labor if the product is deemed to have been misused, neglected, involved in an accident, abused, loaded beyond the product's limits, modified, installed improperly or connected incorrectly to any electrical component. Normal maintenance is not covered by this warranty and is not required to be performed at a facility or by a person authorized by CPE.

Other Exclusions

This warranty excludes:

- Cosmetic defects such as paint, decals, etc.
- Wear items such as filter elements, o-rings, etc.
- Accessory parts such as starting batteries, and storage covers.
- Failures due to acts of God and other force majeure events beyond the manufacturer's control.
- Problems caused by parts that are not original Champion Power Equipment parts.

Limits of Implied Warranty and Consequential Damage

Champion Power Equipment disclaims any obligation to cover any loss of time, use of this product, freight, or any incidental or consequential claim by anyone from using this product. THIS WARRANTY IS IN LIEU OF ALL OTHER WARRANTIES, EXPRESS OR IMPLIED, INCLUDING WARRANTIES OF MERCHANTABILITY OR FITNESS FOR A PARTICULAR PURPOSE.

A unit provided as an exchange will be subject to the warranty of the original unit. The length of the warranty governing the exchanged unit will remain calculated by reference to the purchase date of the original unit. This warranty gives you certain legal rights which may change from state to state or province to province. Your state or province may also have other rights you may be entitled to that are not listed within this warranty.

Contact Information

Address

Champion Power Equipment, Inc.
Customer Service
12039 Smith Ave.
Santa Fe Springs, CA 90670 USA
www.championpowerequipment.com

Customer Service

Mon – Fri 8:30 AM – 5:00 PM (PST/PDT)
Toll Free: 1-877-338-0999
info@championpowerequipment.com
Fax no.: 1-562-236-9429

Technical Service

Mon – Fri 8:30 AM – 5:00 PM (PST/PDT)
Toll Free: 1-877-338-0999
tech@championpowerequipment.com
24/7 Tech Support: 1-562-204-1188